

**NAD SERVICE  
MANUAL**

**7225PE**

**7020i**

**AM/FM RECEIVERS**

## MAIN AMPLIFIER ADJUSTMENT

### IMPORTANT NOTES:

- 1) Before adjusting, remove input signal and load, and set Speaker impedance switch to 8 ohms (reset to 4 ohms when finished).
- 2) These adjustments are always necessary after repair to main amplifier.
- 3) After repair, it is recommended to use current limiter (30-70W lightbulb) in mains line, for initial turn-on.

### A. CENTER VOLTAGE ADJUSTMENT

1. Connect DMM across L channel (R channel) output terminals.
2. Turn on, and adjust R-411 (R-412) for reading of  $0V \pm 30$  mVDC.

### B. IDLE CURRENT ADJUSTMENT

1. Remove solder short across R-455 and R-456.
2. Connect DMM across P-403(—) and P-404 (+).
3. Turn on and adjust R-443 for reading of  $28$  mV  $\pm 2$  mVDC.
4. Repeat, using P-405(+) and P-406(—), adjust R-444.

### C. FINAL ADJUSTMENT

1. Leave power on for a minimum of 5 minutes with no signal connected.
2. Repeat center voltage and idle current adjustments.
3. **WHEN FINISHED, REPLACE SOLDER SHORT ACROSS R-455 AND R-456.**

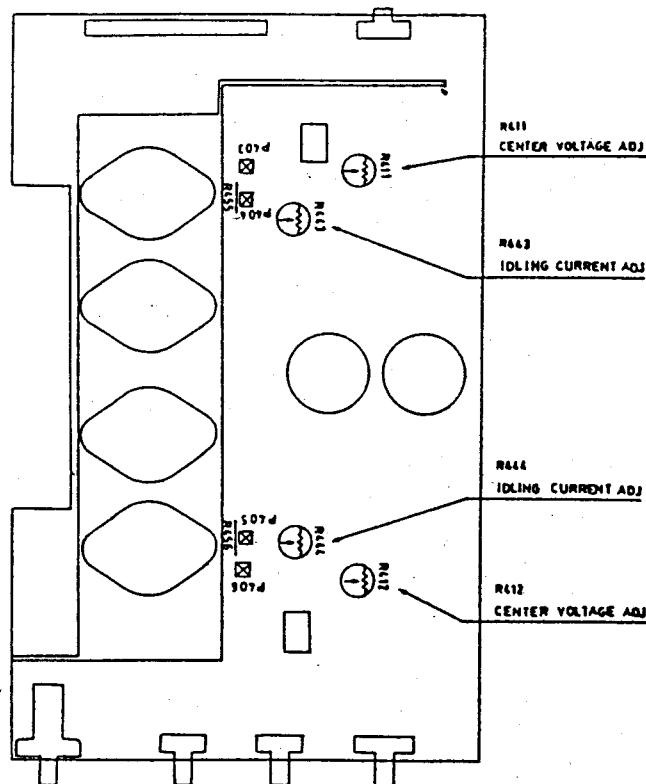

AMPLIFIER ADJUSTMENT POINTS

# FM ALIGNMENT

## I. NECESSARY INSTRUMENTATION

1. FM SIGNAL GENERATOR ( $< 0.03\%$  THD)
2. STEREO MODULATOR ( $< 0.03\%$  THD)
3. 50/75 OHMS DUMMY ANTENNA (If needed by generator)
4. DIGITAL VOLTMETER (DVM)
5. DISTORTION METER ( $< 0.1\%$  resolution)
6. AC VOLTMETER
7. OSCILLOSCOPE ( $< 5$  mV sensitivity)
8. IHF FILTER

## II. IMPORTANT NOTES

1. All equipment must be capable of measuring better than specification of unit under test.
2. 1 KHz modulating signal,  $\pm 75$  KHz deviation, mono unless otherwise stated.
3. All RF levels quoted are at 75 OHMS impedance. If at 300 OHMS impedance, add 6 dBu from figures.
4. Enter the following frequencies: 98, 87.5, 108, 90 and 106 MHz.

## III. PREPARATION

1. Turn I1 (IF) counterclockwise until core is near the top.
2. Turn I102 (FM detector primary) counterclockwise until core is near the top.
3. Turn I103 (FM detector secondary) counterclockwise until core is near the top.

## IV. PROCEDURE

### A. OSCILLATOR TUNING VOLTAGE

1. Connect DVM between P123 and ground.
2. Set tuner to 87.5 MHz and check DVM for a reading of  $3 \text{ VDC} \pm 0.5\text{V}$  ( $1.6 \text{ VDC} \pm 0.3\text{V}$  for C1 version).
3. Set tuner to 108 MHz and check DVM for a reading of  $20.5 \text{ VDC} \pm 0.5\text{V}$  ( $8 \text{ VDC} \pm 0.5\text{V}$  for C1 version).

If either of the above is out of tolerance, adjust L8 (oscillator coil) until both readings are within tolerance.

### B. IF CENTER ADJUSTMENT

1. Connect DVM between P112 and P113.
2. Apply 10.7 MHz (90 dBu) VIA 1K OHM resistor to P111.
3. Adjust I102 (clockwise) for  $0 \text{ VDC} \pm 50 \text{ mV}$  reading on DVM.
4. Adjust I103 (clockwise) until minimum THD is achieved at audio O/P.
5. Repeat (3) and (4) until no further improvement can be made.

NOTE: When adjusting I103 two nulls can be found. Adjust until the second one is found as this has lower THD. Correct position of core is normally just above the metal casing.

### C. SYNTHESIZER / IF TRACKING

1. Maintain connection of DVM and disconnect 10.7 MHz TAP at P111.
2. Apply 98 MHz (54dBu) to 75 OHMS antenna input and tune to 98 MHz.
3. Adjust C917 for  $0 \text{ VDC} \pm 20 \text{ mV}$  reading on DVM.
4. Fine adjust I103 for minimum THD.
5. Repeat (3) and (4) until no further improvement can be made.

### D. I1 ALIGNMENT

1. Connect DVM between wiper of R117 (right of R159) and ground.
2. Turn R117 fully counterclockwise.
3. Apply 98 MHz (6dBu) to antenna input.
4. Carefully adjust I1 to obtain maximum reading on DVM. There should only be one maximum.

### E. RF ADJUSTMENT

1. Apply 98 MHz (6dBu) to antenna input.
2. Check if THD is better than 3%. If not, proceed to (3).
3. Adjust L2, L4 and L5 by squeezing or stretching using a non-metallic tool until THD is better than 3%.
4. Repeat (3) at 90 MHz and 106 MHz and re-adjust until THD is within 3% at 7dBu for both frequencies and 6 dBu for 98 MHz.

### F. AUTOSEARCH LEVEL

1. Connect DVM between wiper of R117 (right to R159) and ground.
2. Apply 98 MHz (60dBu) to antenna input and tune to 98 MHz.
3. Adjust R117 to get  $1.05 \text{ VDC} \pm 0.01 \text{ V}$  reading on DVM.
4. Check if autosearch operation is working properly at antenna signal level of 26dBu (20uV).

### G. STEREO SEPARATION AND PILOT SUPPRESSION

1. Modulate L-only at 98 MHz (60dBu) and adjust R127 for minimum output on right channel.
2. Modulate R-only and adjust R127 for minimum output on left channel.
3. Repeat (1) and (2) until readings are the same and within specs.
4. Cancel stereo modulation and leave pilot tone.
5. Adjust Z105 and Z106 for minimum output on left and right channels, respectively.

## AM ALIGNMENT

### I. IMPORTANT NOTES

1. 1 KHz 30% modulation.
2. 22 pF connected between signal generator and AM antenna terminal. Capacitor should be as close as possible to antenna terminal.
3. Enter the following frequencies: 600 (603)KHz, 1000 (999)KHz and 1400 (1404)KHz.

### II. PROCEDURE

#### A. OSCILLATOR TUNING VOLTAGE

1. Connect DVM between P123 and ground.
2. Set tuner to 600 (603)KHz and adjust L102 for  $1.75V \pm 50mV$  reading on DVM.

#### B. IF ADJUSTMENT

1. Apply 1000 (999)KHz 20dBu to antenna terminals.
2. Adjust I101 for maximum reading on audio output.

#### C. TRACKING ADJUSTMENT

1. Apply 600 (603)KHz 20dBu to antenna terminals.
2. Adjust L101 for maximum reading on audio output.
3. Apply 1400 (1404)KHz 20dBu to antenna terminals.
4. Adjust C138 for maximum reading on audio output.
5. Repeat (1) to (4) until no further improvement can be made.

#### D. AUTOSEARCH / TUNER LEVEL

1. Apply 1000 (999)KHz 20 dBu.
2. Adjust R116 so that tune LED just lights fully.

# TUNER ADJUSTMENT POINTS

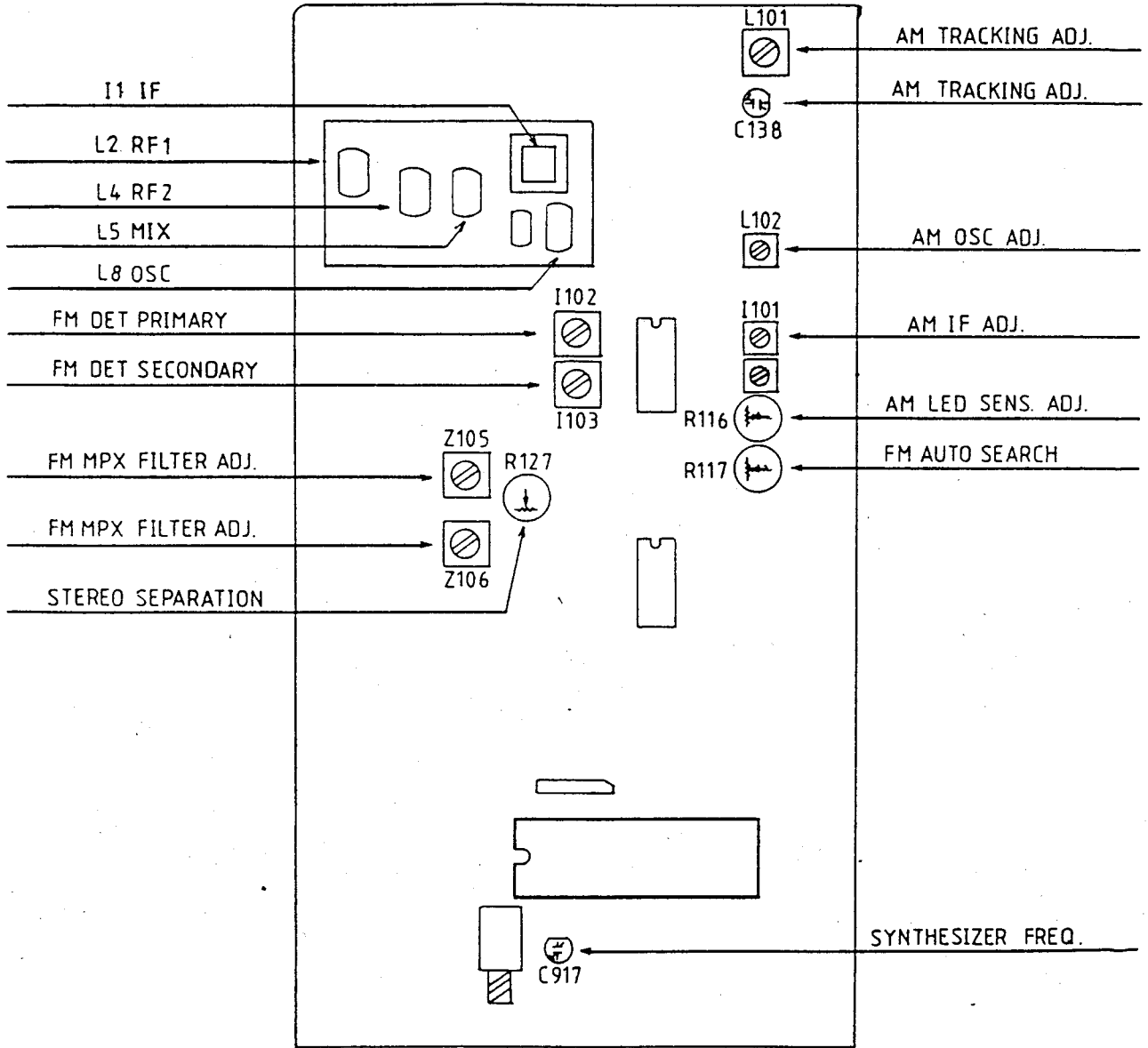



PCB LAYOUT AND WIRING DIAGRAM, TUNER, 7225PE/7020i

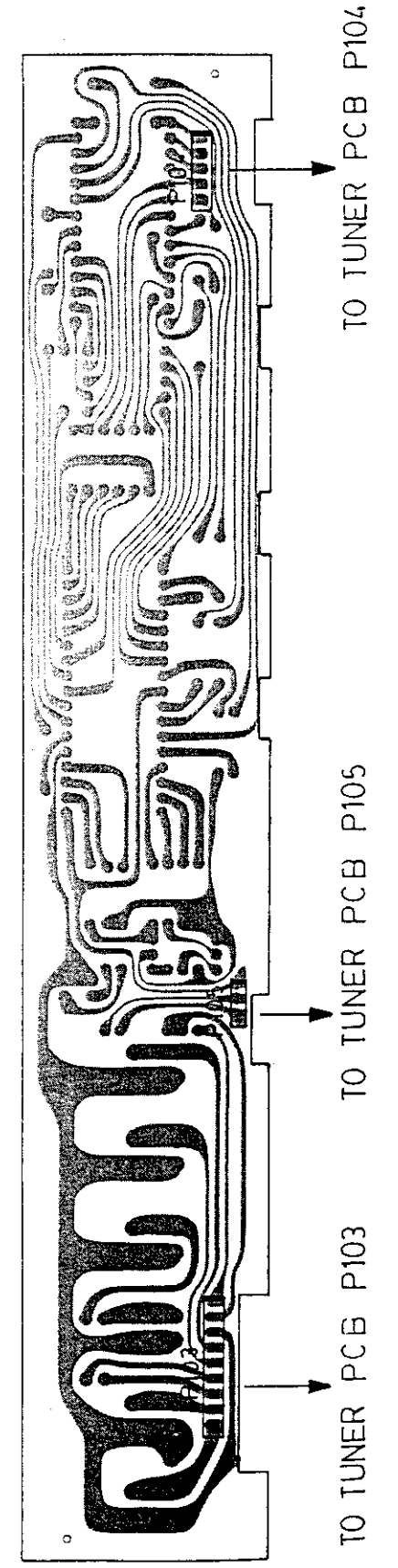
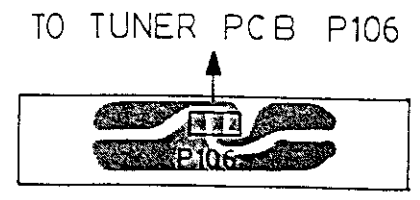
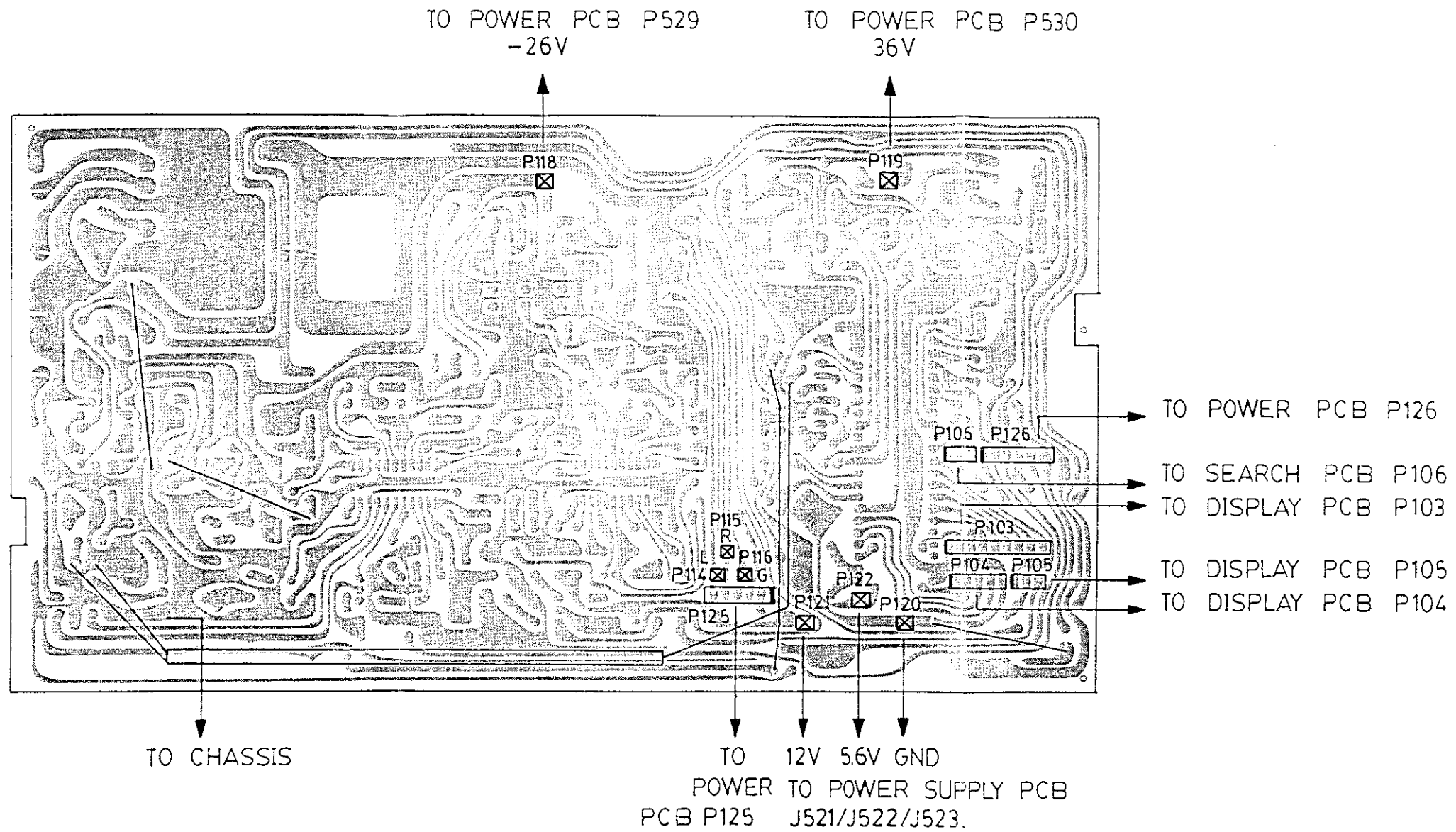

TUNER PCB LAYOUT 7225PE/7020i

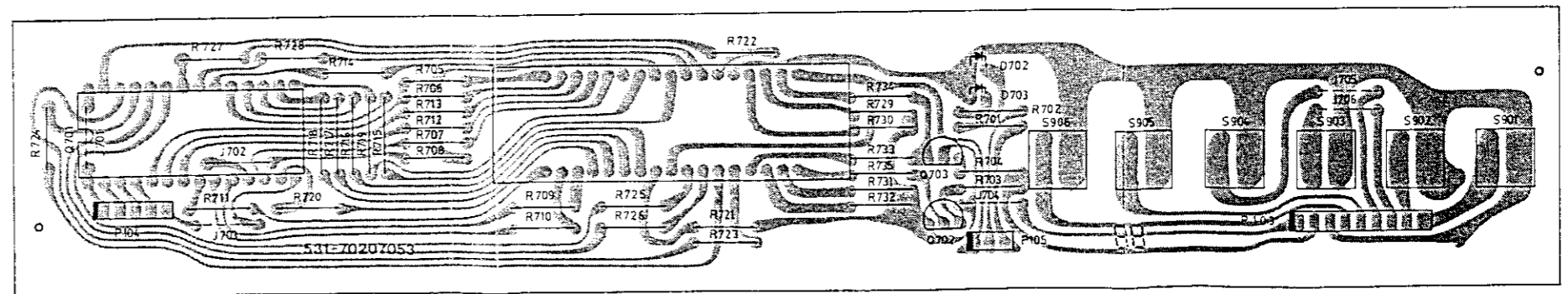
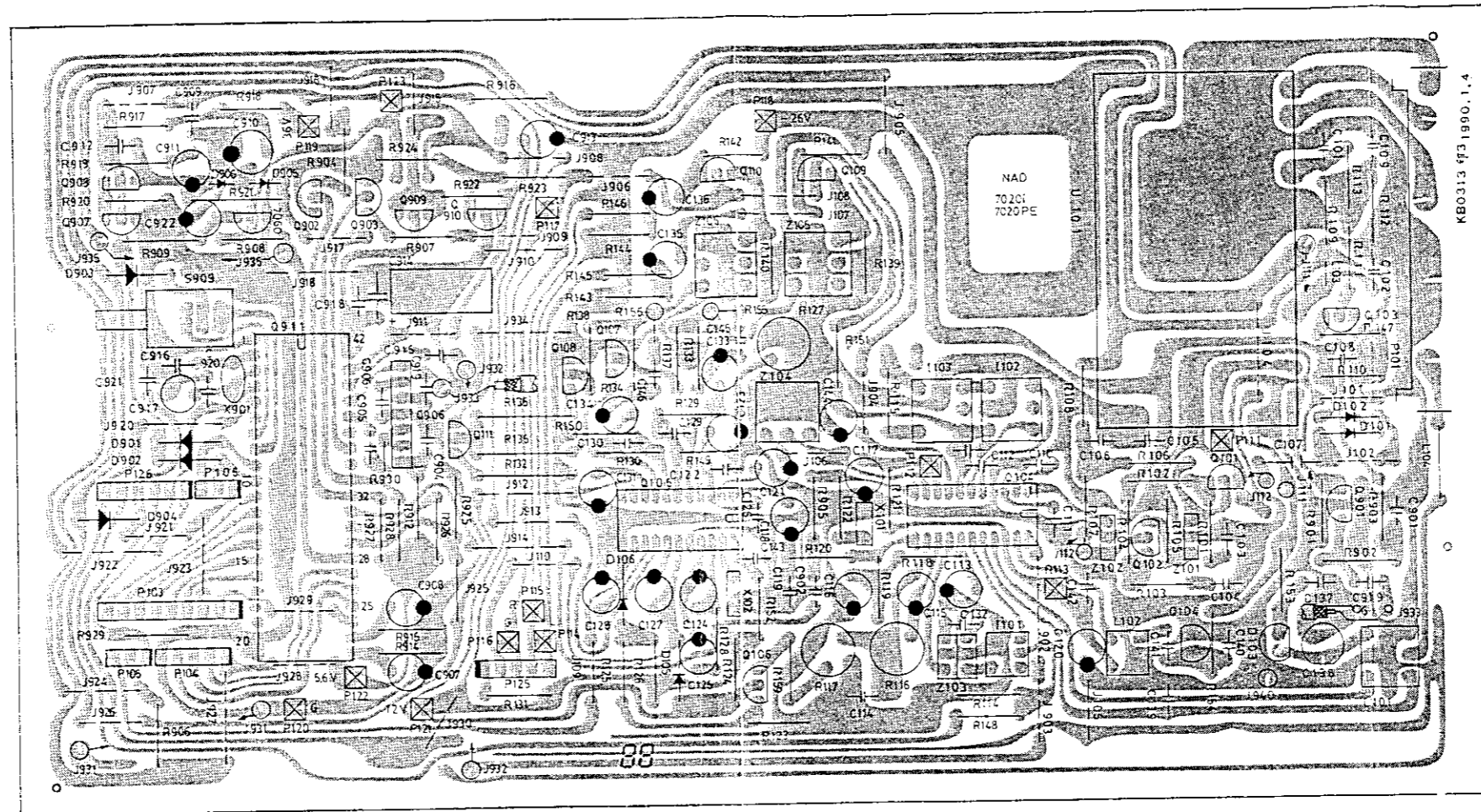



SCHEMATIC DIAGRAM NAD 7225PE AMPLIFIER

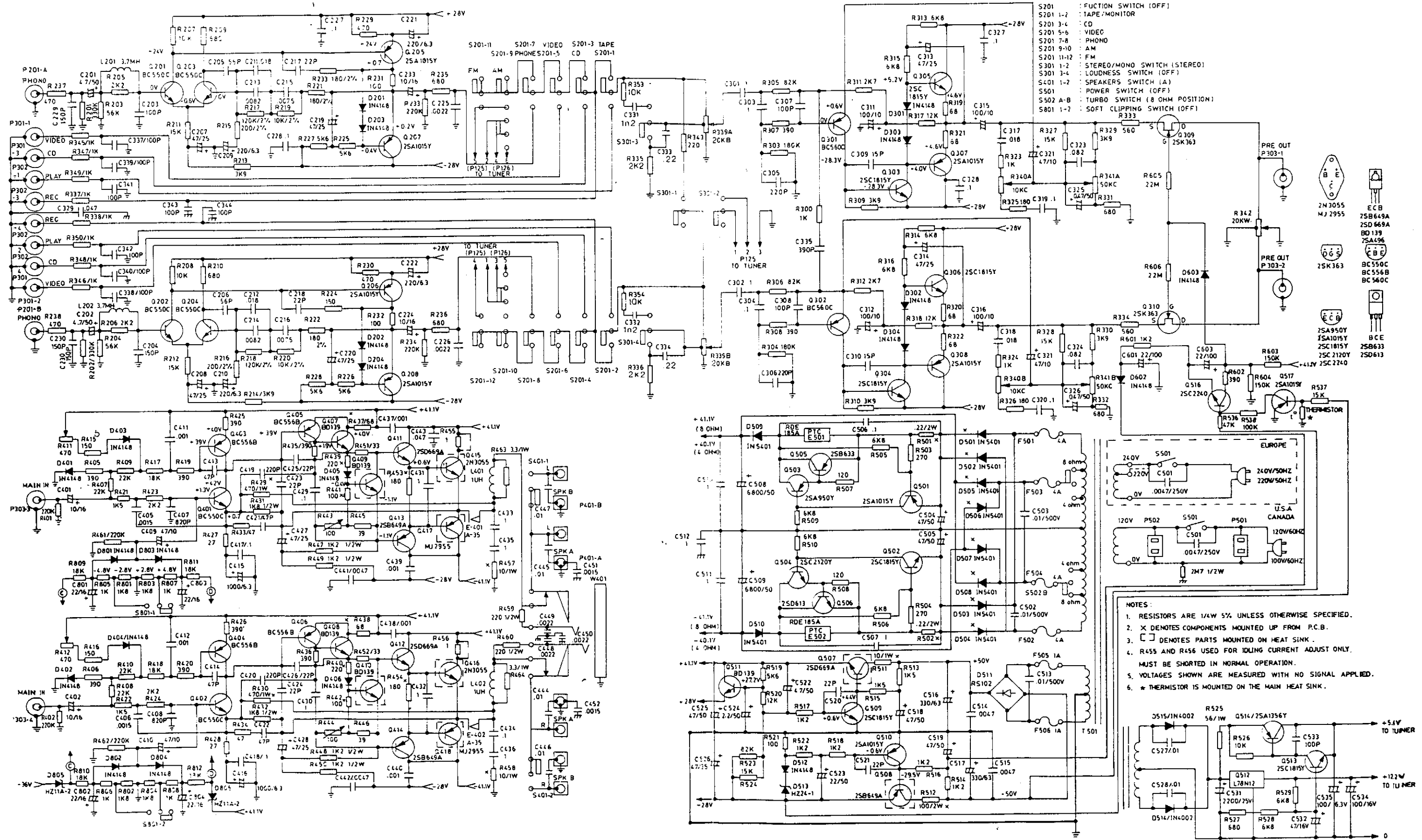

- S201 FUNCTION SWITCH (OFF)
- S201 1-2 TAPE/MONITOR
- S201 3-4 CD
- S201 5-6 VIDEO
- S201 7-8 PHONO
- S201 9-10 AM
- S201 11-12 FM
- S301 1-2 STEREO/MONO SWITCH (STEREO)
- S301 3-4 LOUDNESS SWITCH (OFF)
- S401 1-2 SPEAKERS SWITCH (A)
- S501 POWER SWITCH (OFF)
- S502 A-B TURBO SWITCH (8 OHM POSITION)
- S801 1-2 SOFT CLIPPING SWITCH (OFF)

- NOTES:
1. RESISTORS ARE 1/4W 5% UNLESS OTHERWISE SPECIFIED.
  2. X DENOTES COMPONENTS MOUNTED UP FROM P.C.B.
  3. [ ] DENOTES PARTS MOUNTED ON HEAT SINK.
  4. R455 AND R456 USED FOR IDLING CURRENT ADJUST ONLY. MUST BE SHORTED IN NORMAL OPERATION.
  5. VOLTAGES SHOWN ARE MEASURED WITH NO SIGNAL APPLIED.
  6. \* THERMISTOR IS MOUNTED ON THE MAIN HEAT SINK.