



SERVICE MANUAL

MONITOR SERIES

7000

RECEIVER

PAGE	NAD-7000 CONTENTS
3	REAR / FRONT VIEW
4	SPECIFICATIONS
5	REMOTE CONTROL TRANSMITTER
6	MAIN AMPLIFIER ADJUSTMENT POINTS
7	MAIN AMPLIFIER ADJUSTMENT METHOD
7	PREAMPLIFIER ADJUSTMENT METHOD
8	SUGGESTED HOOKUP FOR FM ALIGNMENT
9-11	FM ALIGNMENT METHOD
11	AM ALIGNMENT METHOD
12	TUNER ADJUSTMENT POINTS
13-14	MAIN AMPLIFIER PCB LAYOUT
15-16	MAIN AMPLIFIER SCHEMATIC
17-18	PREAMPLIFIER PCB LAYOUT
19-20	PREAMPLIFIER SCHEMATIC
21-22	TUNER PCB LAYOUT
23-24	TUNER SCHEMATIC
25-26	REMOTE/DISPLAY PCB LAYOUT
27-28	REMOTE/DISPLAY SCHEMATIC
29	MAIN AMPLIFIER WIRING
30	PREAMPLIFIER WIRING
31	TUNER AND REMOTE/DISPLAY WIRING
32	DIFFERENT PARTS LIST
33-35	ELECTRICAL PARTS LIST
36	EXPLODED VIEW
37	EXPLODED PARTS LIST
38	PACKING DIAGRAM
39	NOTES

REMOTE CONTROL TRANSMITTER

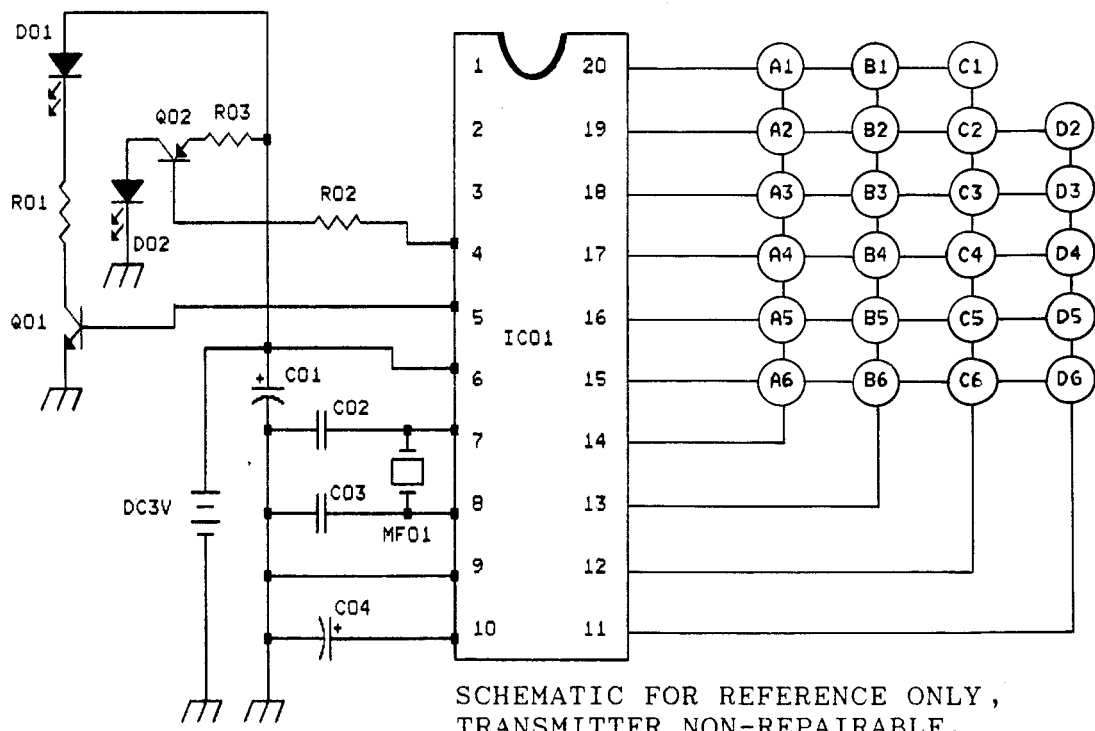
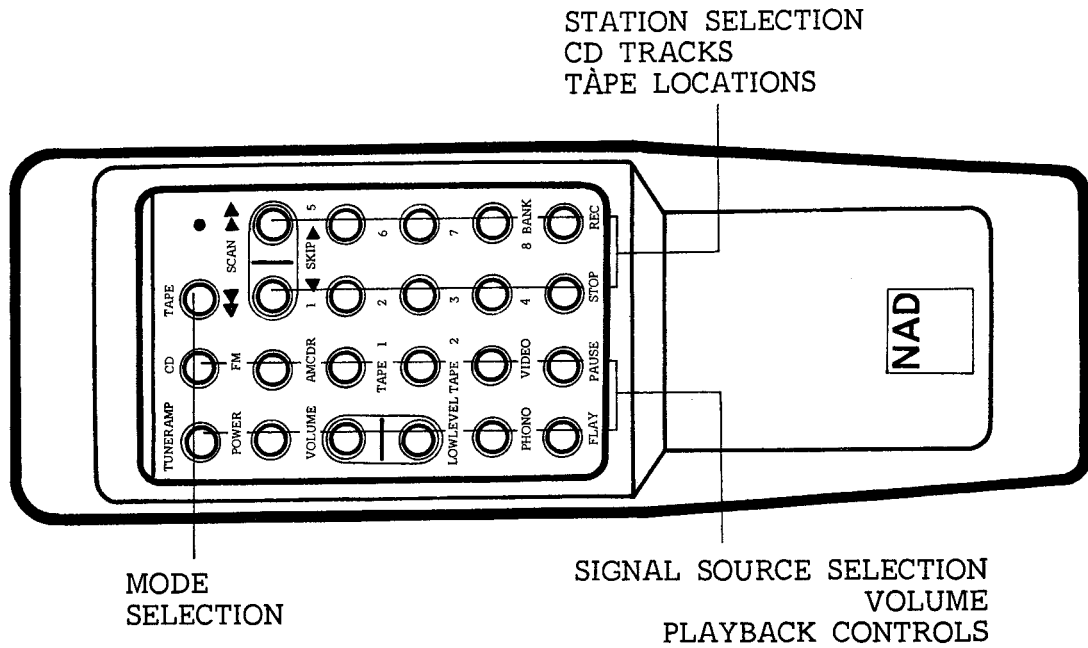

SCHEMATIC FOR REFERENCE ONLY,
TRANSMITTER NON-REPAIRABLE.

MAIN AMPLIFIER ADJUSTMENT POINTS

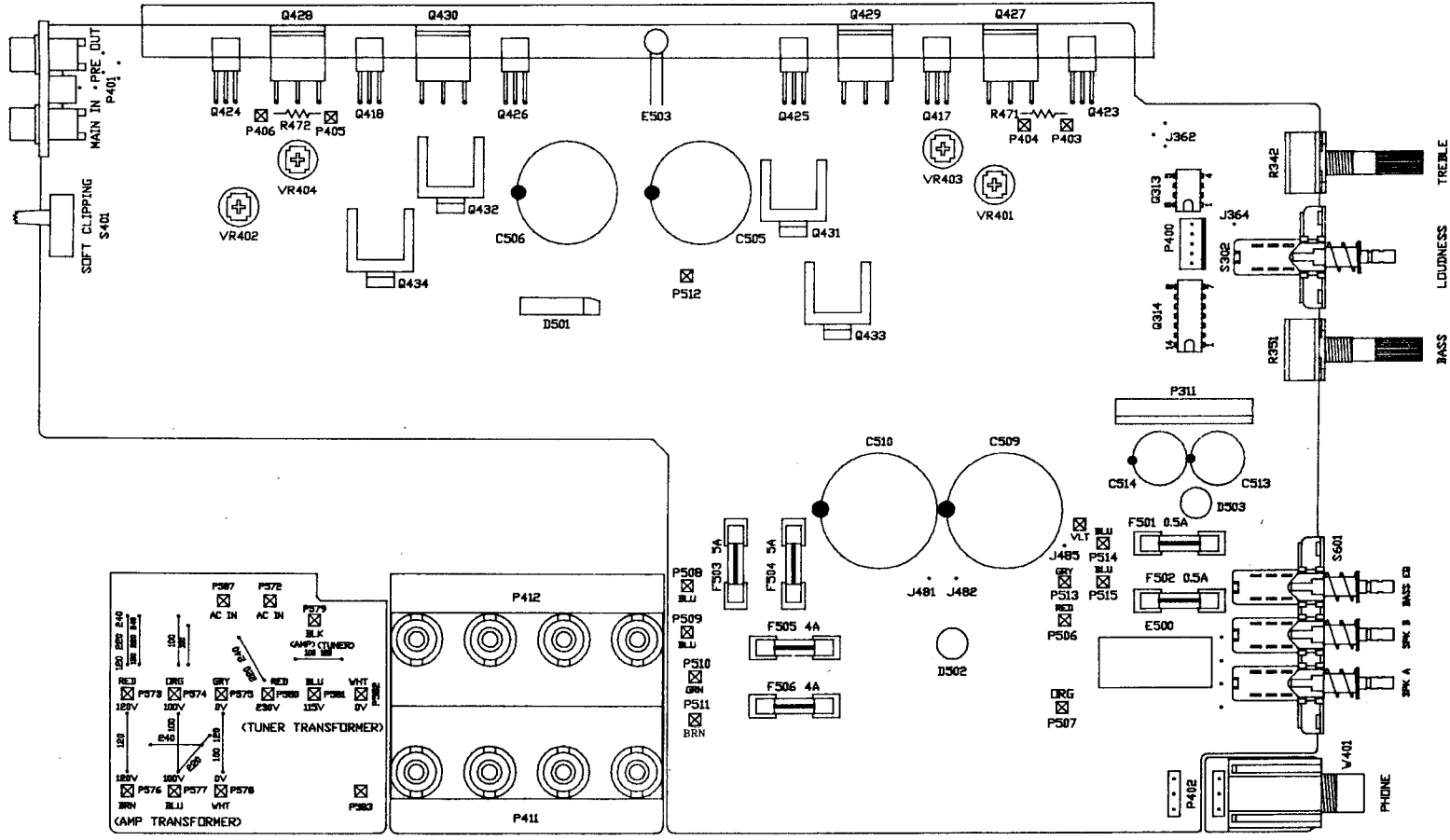

MAIN AMPLIFIER ADJUSTMENT

IMPORTANT NOTES:

- 1) Before adjusting, remove input signal and load, and set Speaker impedance switch to 8 ohms (reset to 4 ohms when finished).
- 2) These adjustments are always necessary after repair to main amplifier.
- 3) After repair, it is recommended to use current limiter (70-100W lightbulb) in mains line, for initial turn-on.

INITIAL ADJUSTMENT (NO LOAD CONNECTED)

A. CENTER VOLTAGE

1. Connect DC millivoltmeter to L channel output terminals.
2. Turn on and adjust to 0 v \pm 30mV with VR401 (10KB). connect DC millivoltmeter to R channel output terminals and adjust VR402 to 0 v \pm 30mV.

B. IDLE CURRENT

1. Remove solder short across R471 ad R472.
2. Connect DC millivoltmeter across R471 (1 ohm) (output transistor's collector resistor) and adjust VR403 (470 ohm) for 26-30mV reading on meter.
Repeat adjust with VR404 (470 ohm) connecting meter across R472(1 ohm).
3. Leave power on for minimum 5 minutes.

FINAL ADJUSTMENT

C. CENTER VOLTAGE

Repeat step A above.

D. IDLING CURRENT

1. Repeat step B and adjust with VR403,VR404 for 30mV reading on meter.
2. After the alignment is finished, 1 ohm resistor R471,R472 is shorted by solder short.

PREAMPLIFIER ADJUSTMENT

A. CHANNEL BALANCE

1. Feed 1kHz, 100mV to CD input; connect AC VTVM's to preamp output.
2. Set volume to maximum, balance to center, low level off.
3. Adjust R-315 so that both channels have same output level \pm 0.25dB.

PREAMPLIFIER ADJUSTMENT POINTS

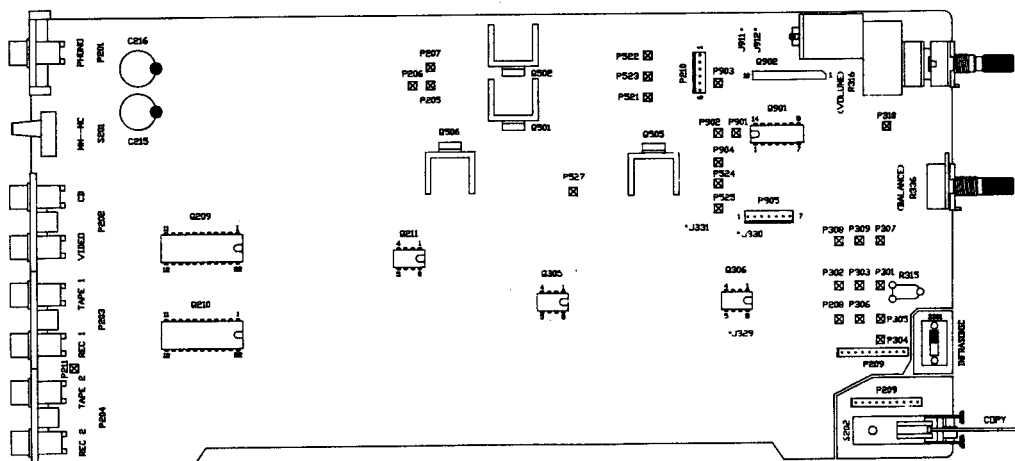

SUGGESTED INSTRUMENTATION HOOKUP- FM ALIGNMENT

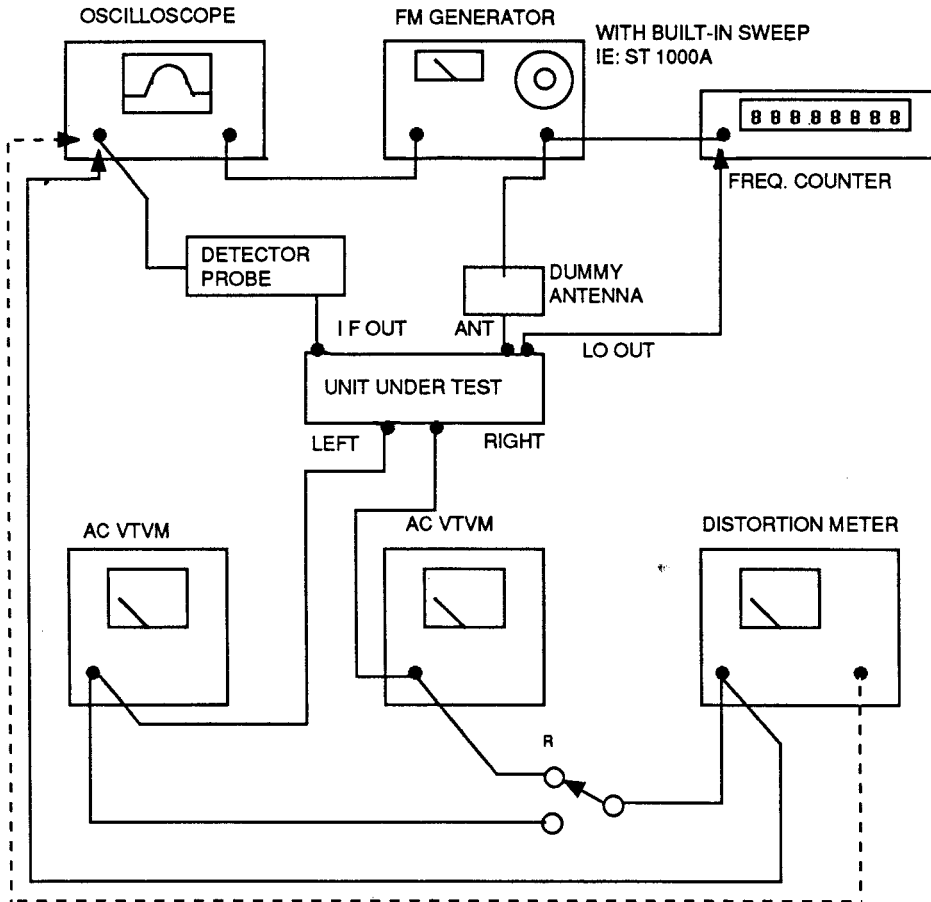
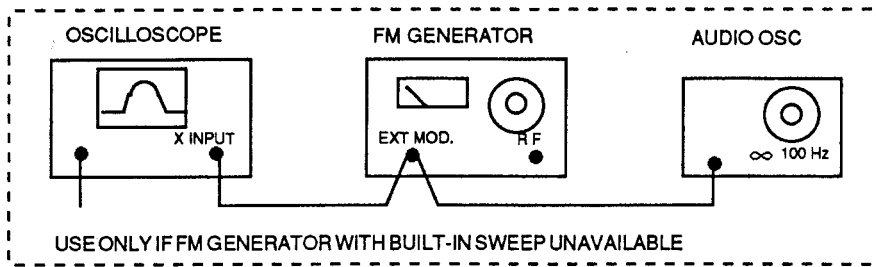

DETECTOR PROBE

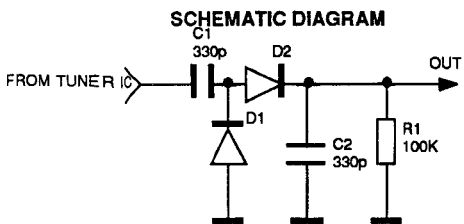

PICTORIAL DIAGRAM

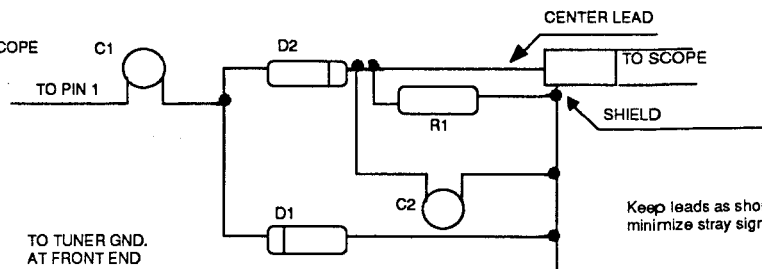

Keep leads as short as possible, to minimize stray signal pickup.

Diodes should be point contact germanium; some types commonly available are:

- O80
- O81
- All 1 9
- 1150
- 1134
- 1122

INDUCTOR TEST PROBE

THIN BRASS,
2x10 mm approx

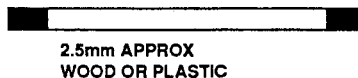

FERRITE
2-3 mm DIA

BRASS, FERRITE
FROM RF COIL.
FASTEN WITH
GLUE

FM ALIGNMENT

NECESSARY INSTRUMENTATION:

- * Stereo Modulator (less than 0.05% THD, more than 50dB Sep.)
- * FM Generator (less than 0.05% THD)
- * 75 ohm Dummy Antenna (if needed by generator)
- * Audio Oscillator (not necessary if FM generator has built-in sweep, e.g., SOUND TECHNOLOGY ST 1000A or ST 1020A)
- * 2 AC VTVM's (or one with a Left/Right switch)
- * THD Analyzer (resolution less than 0.1%)
- * Oscilloscope (5mV or better sensitivity, X-Y capability)
- * Frequency Counter
- * Diode Detector Probe
- * Ferrite/Brass inductor test probe

IMPORTANT NOTES

- 1) RF levels are at antenna input.
- 2) Before aligning, select FM, switch off MONO.
- 3) If FM Generator is not synthesizer-type, be sure to check its frequency with Frequency Counter When adjusting detector and stereo decoder circuits.
- 4) Hum in measurements may be caused by ground loop via antenna cable; if so, use isolation balun, or isolate cable shield and hot with small capacitors (470 ~ 1000pf).
- 5) To adjust front-end coils, bend gently with wooden or plastic tool (non-interactive).
- 6) ENTER the following frequencies: 90.00, 105.00, 87.50, 108.00, 98.00

A. LOCAL OSCILLATOR FREQUENCY

1. Connect Frequency Counter between front-end pin 8 (front-most) and Ground.
2. Tune to 90 MHz (No RF input needed).
3. Adjust C-934 so that reading is $100.700\text{MHz} \pm 2\text{KHz}$.
4. Remove counter.

B. TUNING VOLTAGE

1. Connect DMM between P-936 and Ground.
2. Tune to 108.00MHz, and adjust L-7 if reading is not $20.0\text{V} \pm 0.5\text{V}$
3. Tune to 88.00MHz, and check that reading is $3.0\text{V} \pm 0.5\text{V}$
4. Repeat until within tolerance.

C. TRACKING

1. Connect FM Generator to 75 ohm antenna input (modulate $\pm 150\text{kHz}$ sweep) and Detector Probe to Pin 1 of Q106 (ground to tuners shield).
2. Adjust vertical sensitivity of Oscilloscope to maximum, and set to X-Y mode. (X input is sweep signal, Y is detector probe).
3. Tune to 105MHz and adjust generator so that curve appears on Oscilloscope, and covers approximately 1/2 of display.
4. Check L2, L3, L4 with ferrite/brass probe, adjust only if probe causes curve height to increase more than 10%. If necessary, reduce generator output to keep entire curve on display.

5. Tune to 90MHz and adjust Generator so that curve appears on Oscilloscope.
6. Check L2, L3, L4 again; if necessary, distribute any error between both frequencies.

Note: 105MHz curve is typically slightly higher than 90MHz.

D. IF ADJUSTMENTS

1. Tune to approximately 98MHz (must be an unoccupied frequency), and adjust FM Generator to display curve on the oscilloscope.
2. Adjust I-1 and I-101 for maximum and symmetrical curve using as little RF input signal as possible.
3. Remove detector probe.

E. DETECTOR ADJUSTMENT

1. Remove Detector Probe, and connect Tape Output to Distortion Analyzer and Oscilloscope.
2. Connect DMM between P-703 (-) and P-704 (+).
3. Tune to 98MHz and feed 1000uV from FM Generator (Modulate 1kHz 100%, Mono).
4. Adjust I-102 Secondary (front) for lowest THD. Specification: less than 0.1%
5. Adjust L-102 Primary (rear) for $0V \pm 50mV$ reading on DMM.
6. Repeat until no further improvement.

F. STEREO DISTORTION & SEPARATION

1. Tune to 98MHz and feed 1000uV from FM Generator. Modulate 1kHz, 100% left (or right) only.
2. Adjust I-1 just slightly so that distortion on left (or right) channel becomes minimum.
3. Check stereo distortion, wide IF; Specification: less than 0.1% , L + R, L only, R only, L - R.
4. Set IF to wide and modulate L only. Adjust R-176 for minimum output on right channel.
Next, modulate R only and adjust R-176 for minimum output on left channel.
If necessary, readjust R-176 so that readings become same on both channels. Specification: less than -45dB.

G. AUTO SEARCH LEVEL

1. Set IF to wide. Connect DMM between P-935 and Ground.
2. Set FM Generator output to 10uV and adjust R-144 so that reading just goes from 0 V to 4.4V. Tolerance: $\pm 2uV$.

H. STEREO SWITCHING LEVEL

1. Set FM Generator output to 5uV, 1kHz 100% L + R.
2. Adjust R-148 so that the stereo light just turns on. Tolerance: $\pm 1 \mu\text{V}$.

NOTE: The tuner will switch into mono at a lower level, typically 4uV.

I. SIGNAL METER LEVEL

1. Set FM Generator output to 500 uV
2. Adjust R-141 so that fifth LED just lights.

J. MULTIPLEX FILTERS

1. Set FM Generator output to 1000uV, 1kHz 100% L + R, and set reference for S/N measurement. Cancel the stereo modulation and leave pilot tone.
2. Adjust Z-111 (Z-112)(rear slug) for minimum subcarrier output on left (right) channel; Specification: less than -60dB.
3. Reduce FM Generator output so that S/N ratio reads 50dB.(Approx 18uV)

AM ALIGNMENTS

A. TUNING VOLTAGE

1. Connect DMM between P-936 and Ground.
2. Tune to 1600(1602)KHz. Enter into Preset 2. Adjust C-137 for reading of $8.1\text{V} \pm 0.5\text{V}$.
3. Tune to 520(522)kHz. Enter into Preset 1. Adjust L-102 for reading of $1.0\text{V} \pm 0.1\text{V}$.
4. Repeat until within tolerance.

B. ANTENNA, IF

1. Swing antenna away from chassis.
2. Connect DC voltmeter to Anode, D110 (rear) and Ground.
3. Tune to a station of moderate strength near 1400kHz. Enter into Preset 4. Adjust C-136 for maximum reading on meter.
4. Adjust I-103 and I-104 for maximum reading on meter.
5. Tune to a station of moderate strength near 600kHz. Enter into Preset 3. Adjust L-101(AM Antenna) for maximum reading on meter (use non-interactive tool, such as plastic or wooden stick).
6. Repeat until no further improvement.

C. SCAN STOP/SIGNAL METER LEVEL

1. Tune to 1000kHz and feed 200uV to antenna terminals.
2. Adjust R-165 so that fifth LED just lights fully.

TUNER ADJUSTMENT POINTS

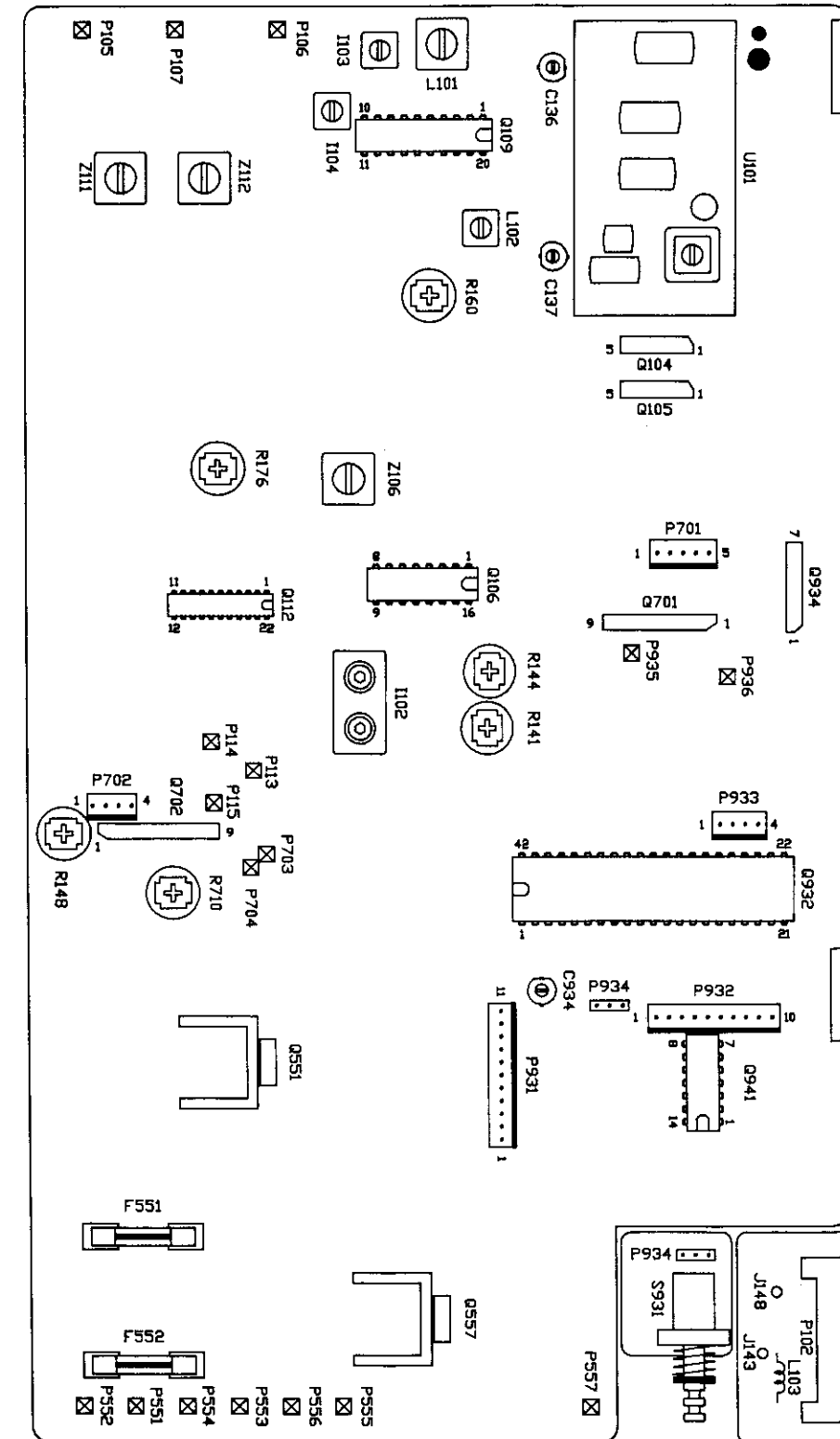

MAIN AMPLIFIER PCB LAYOUT
COMPONENT SIDE

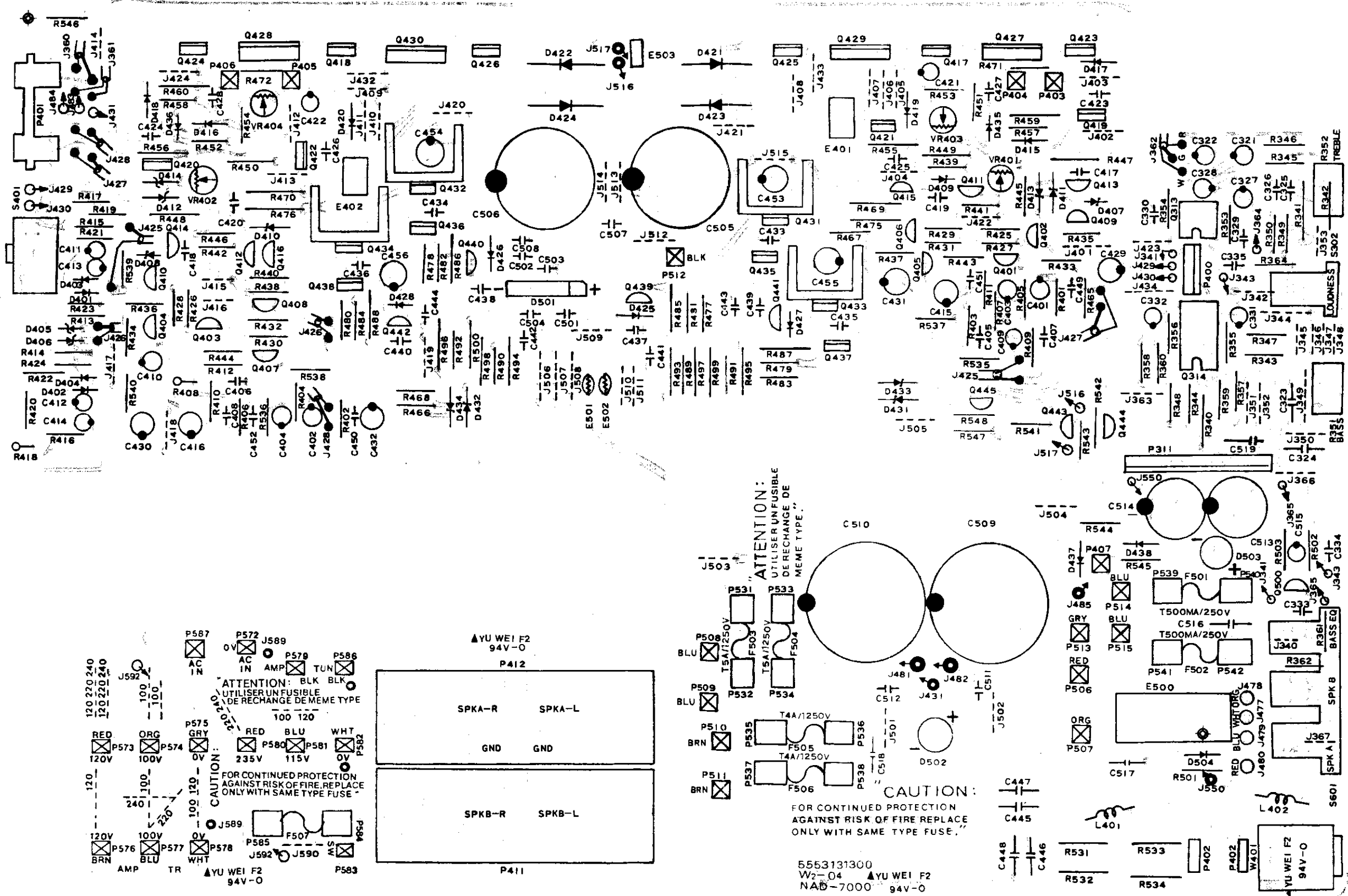

ATTENTION:
UTILISER UN FUSIBLE
DE RECHANGE DE
MEME TYPE.

CAUTION:
FOR CONTINUED PROTECTION
AGAINST RISK OF FIRE REPLACE
ONLY WITH SAME TYPE FUSE.

5553131300
W2-04 ▲YU WEI F2
NAB-7000 94V-0

ATTENTION: BLK
UTILISER UN FUSIBLE
DE RECHANGE DE MEME TYPE

CAUTION:
FOR CONTINUED PROTECTION
AGAINST RISK OF FIRE REPLACE
ONLY WITH SAME TYPE FUSE

▲YU WEI F2
94V-0

SPKA-R SPKA-L

GND GND

SPKB-R SPKB-L

P411

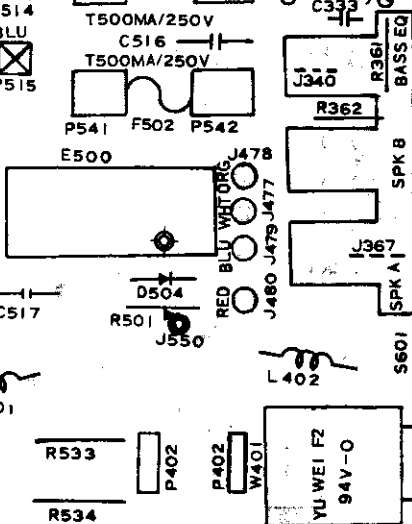

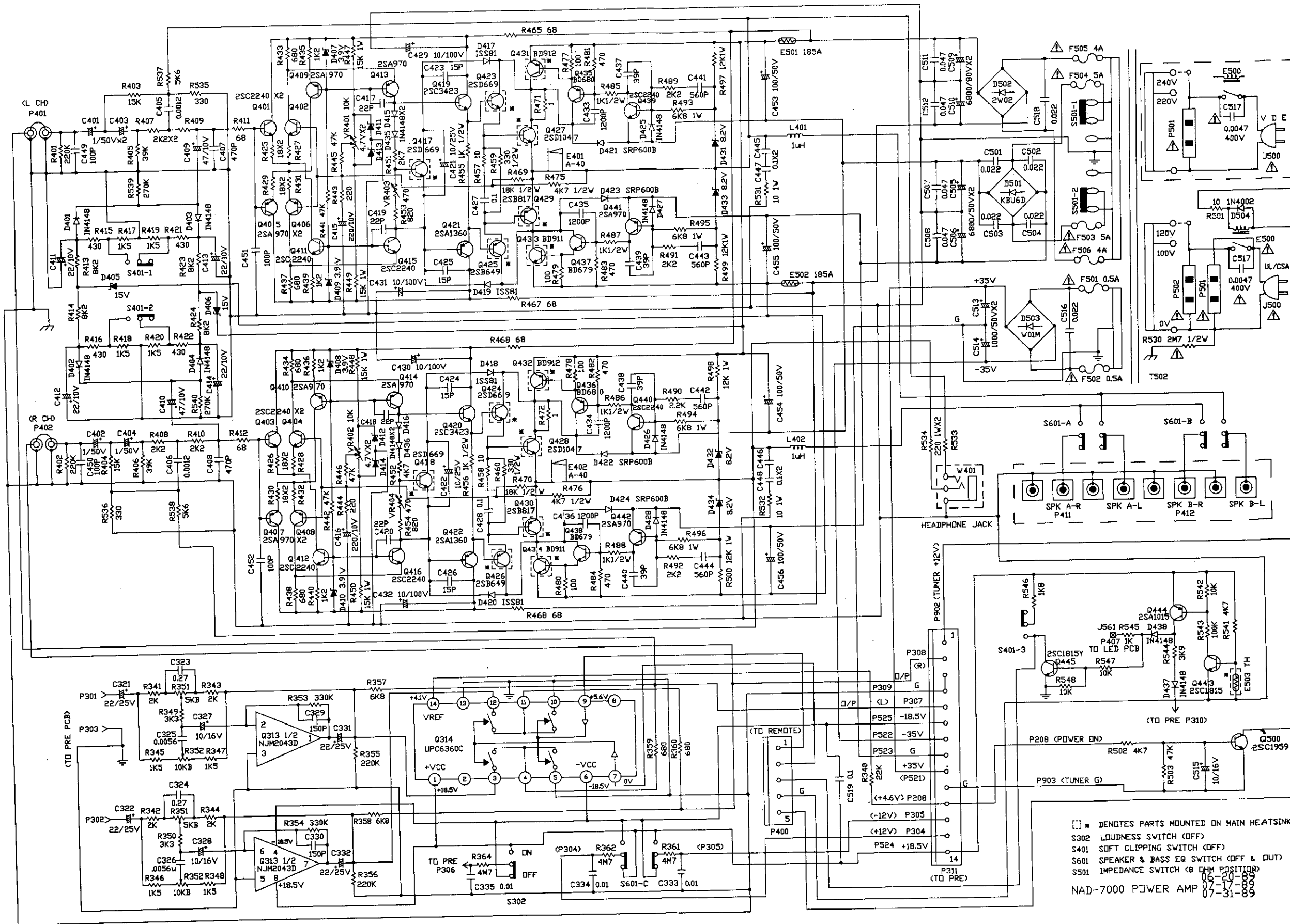

[] * DENOTES PARTS MOUNTED ON MAIN HEATSINK
 S302 LOUDNESS SWITCH (OFF)
 S401 SOFT CLIPPING SWITCH (OFF)
 S601 SPEAKER & BASS EQ SWITCH (OFF & OUT)
 S501 IMPEDANCE SWITCH (8 OHM POSITION)
 06-20-89
 NAD-7000 POWER AMP 07-17-89
 07-31-89

PREAMPLIFIER PCB LAYOUT
COMPONENT SIDE

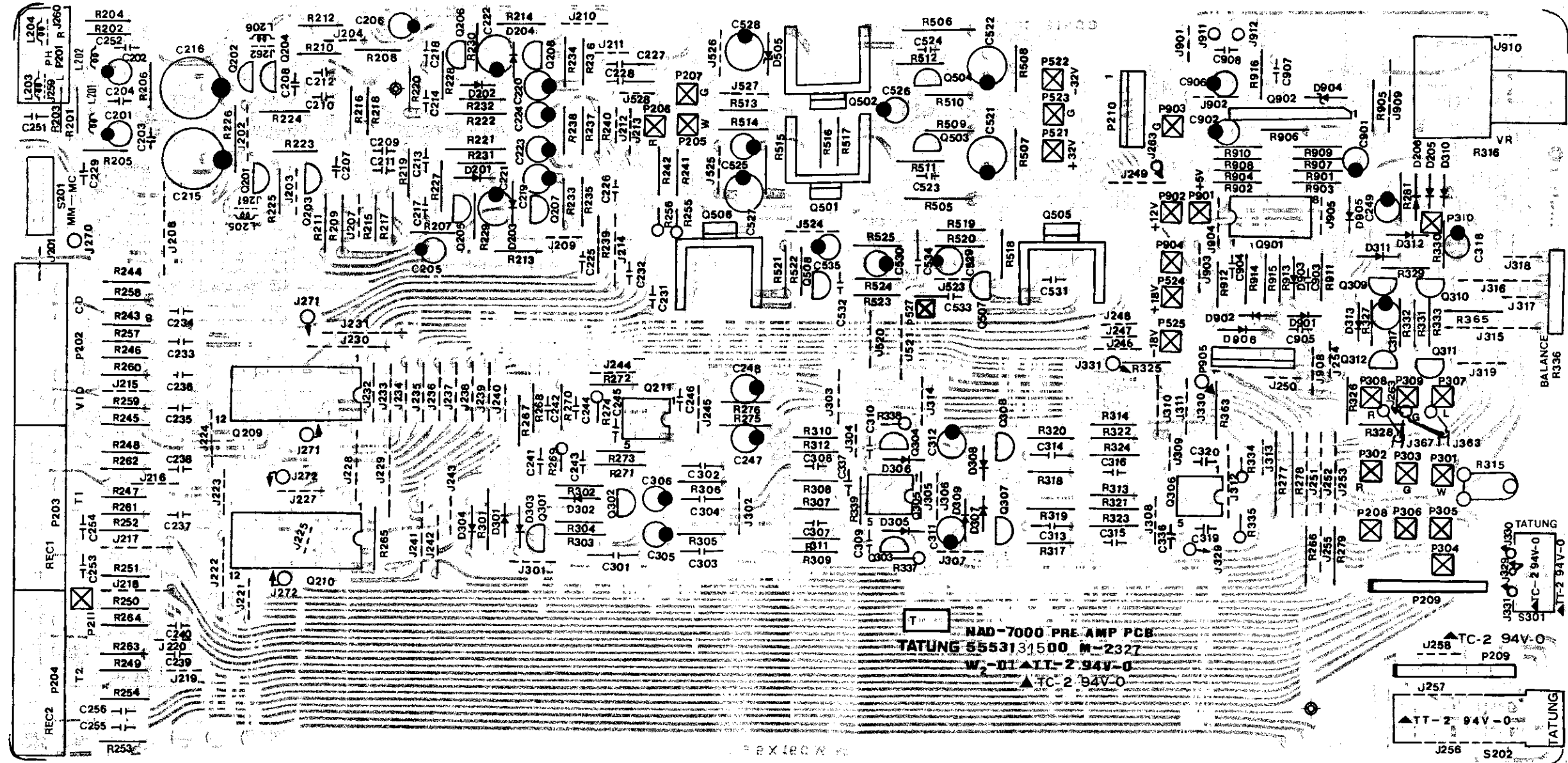

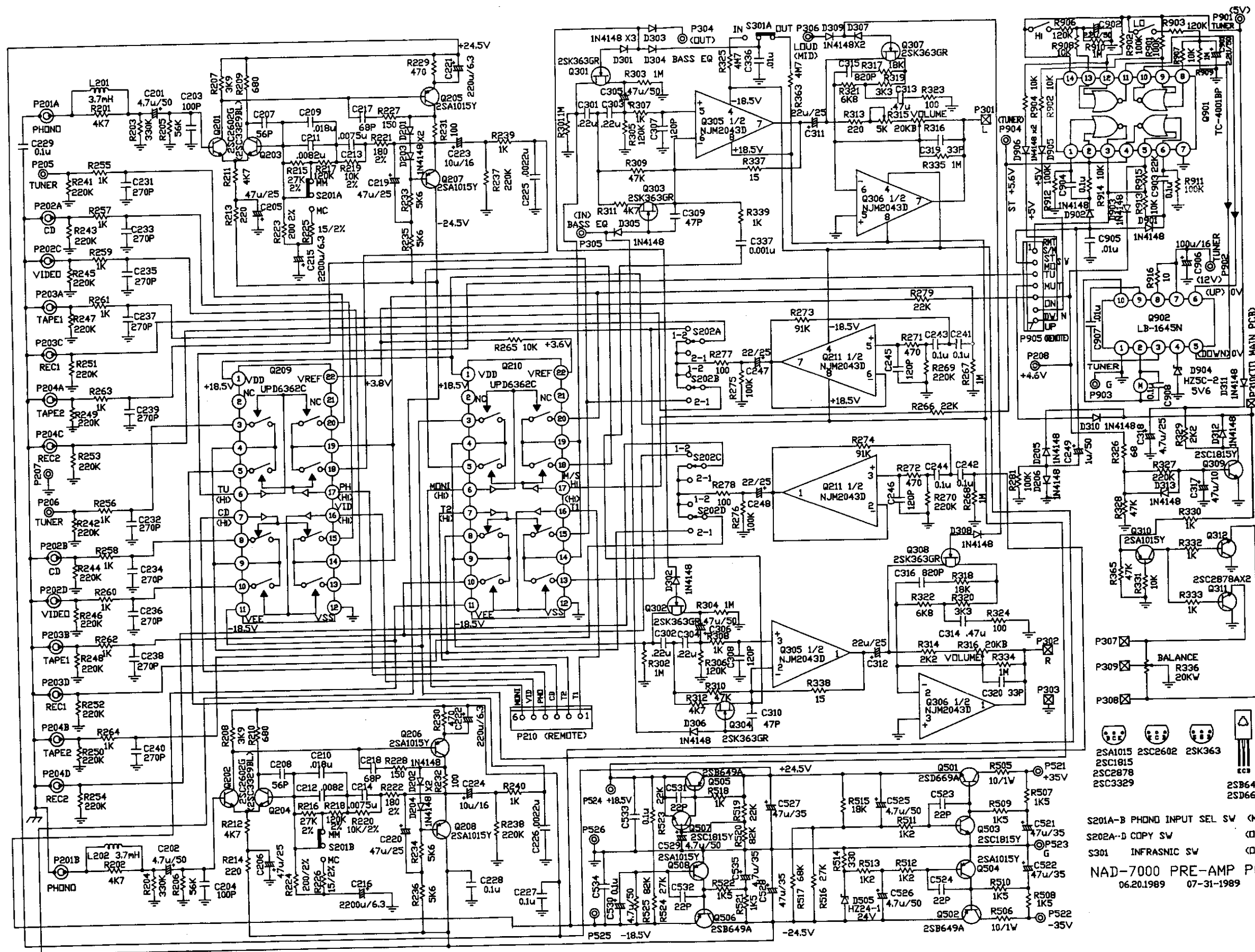

- 2SA1015
 - 2SC2602
 - 2SK363
 - 2SC1815
 - 2SC2878
 - 2SC3329
 - 2SB649
 - 2SD669
 - S201A-B PHONO INPUT SEL SW (MM)
 - S202A-D COPY SW (DIFF)
 - S301 INFRASNIC SW (DUT)
- NAD-7000 PRE-AMP PCB**
06.20.1989 07-31-1989

TUNER PCB LAYOUT
COMPONENT SIDE

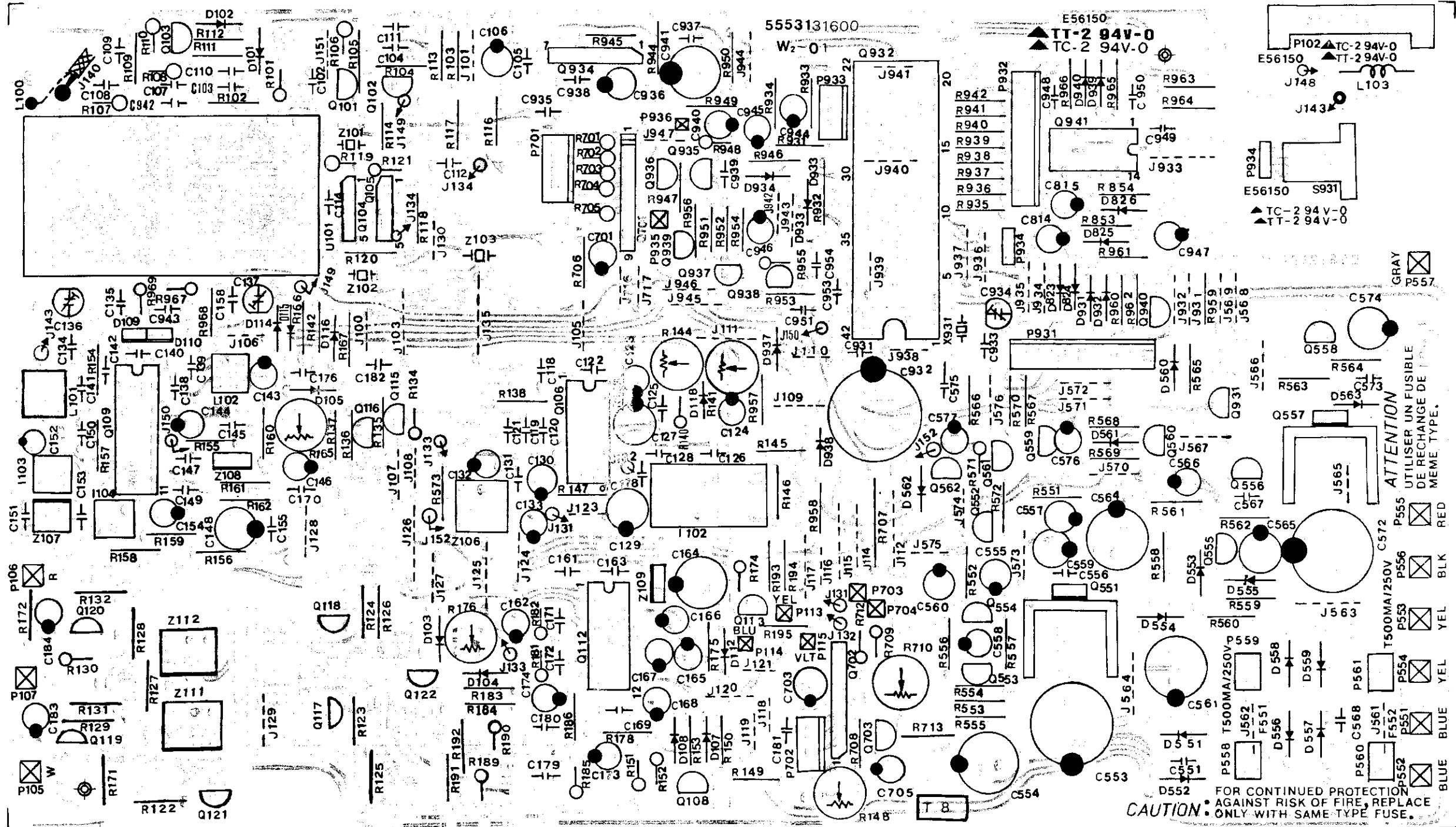

TUNER

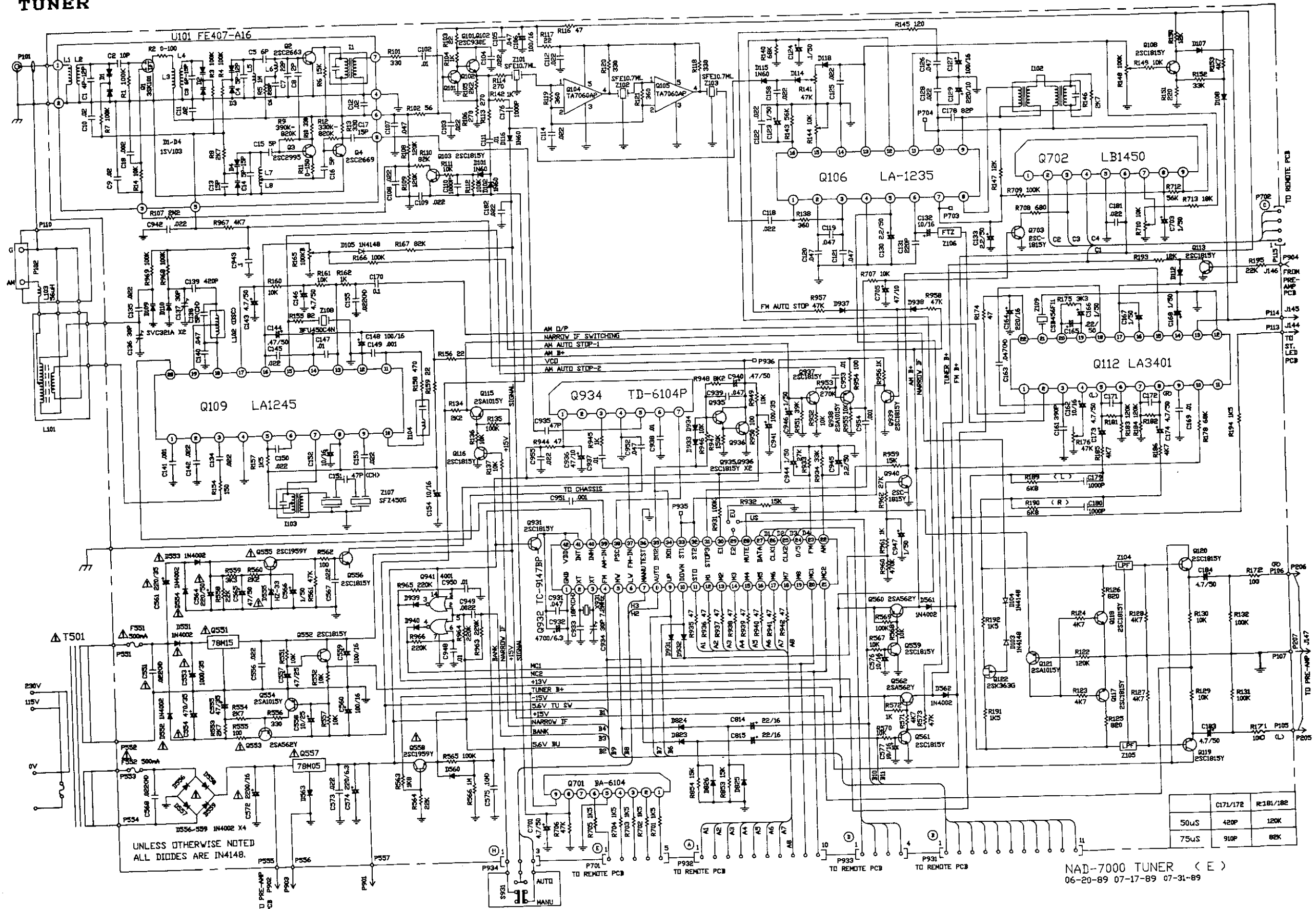

NAD-7000 TUNER (E)
06-20-89 07-17-89 07-31-89

REMOTE/DISPLAY PCB LAYOUT
COMPONENT SIDE

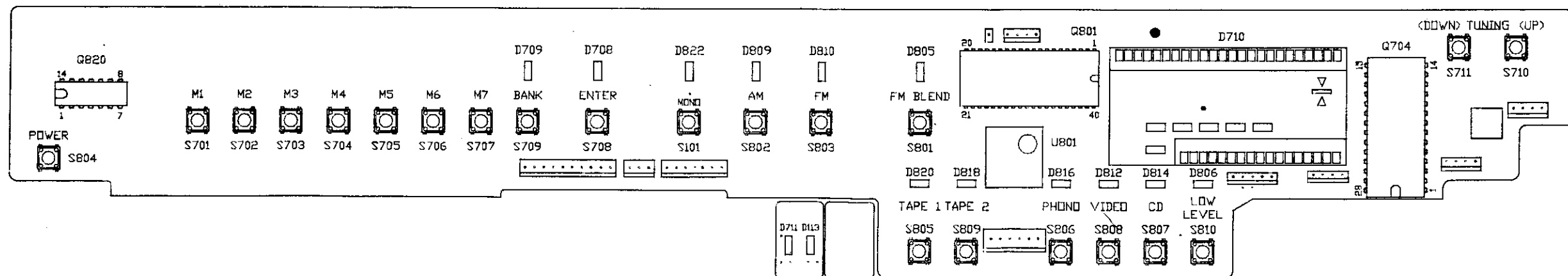
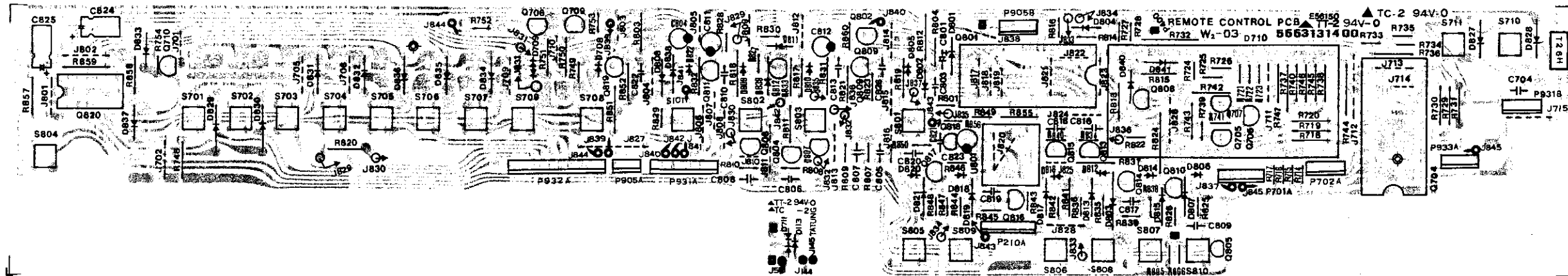

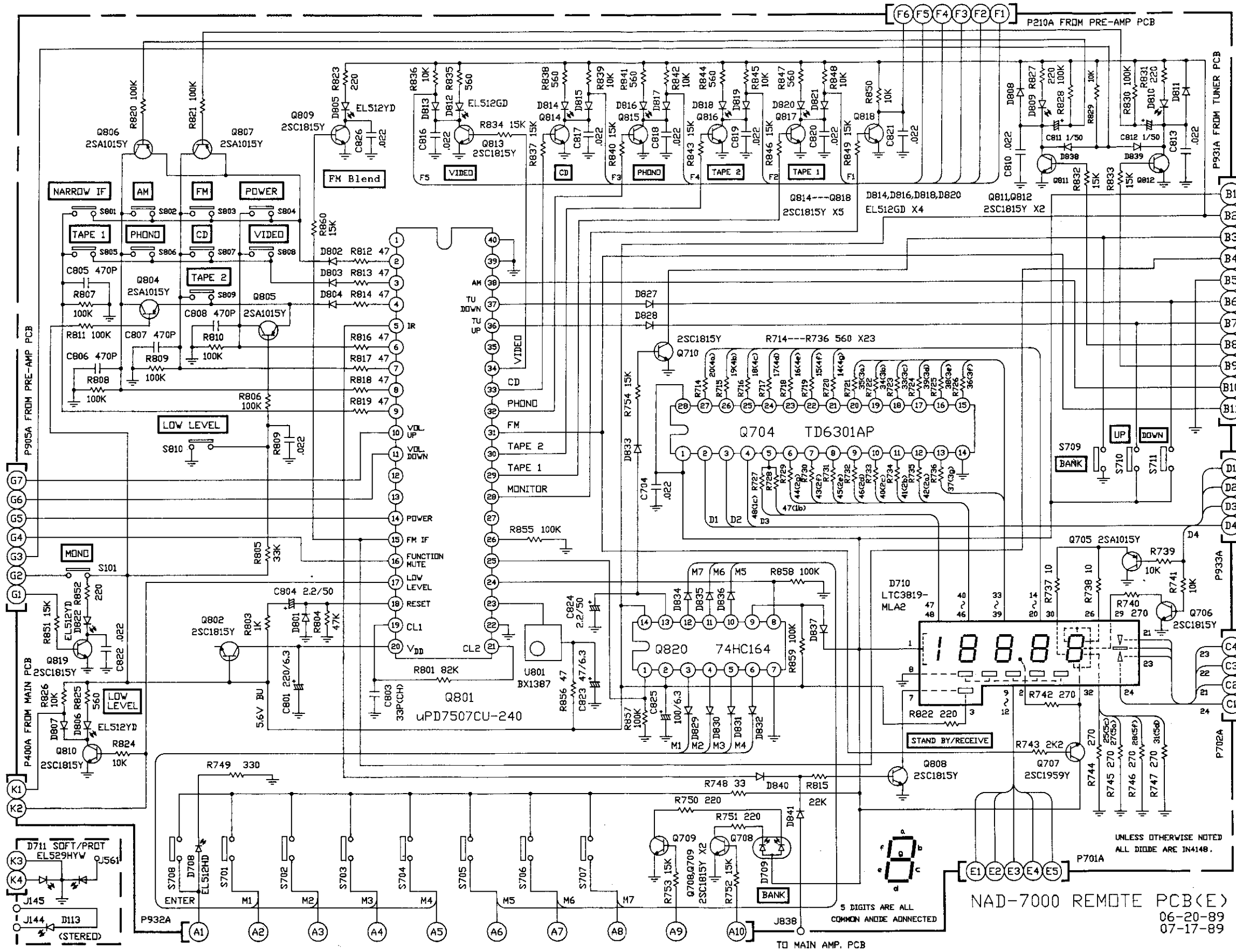

AMPLIFIER WIRING DIAGRAM

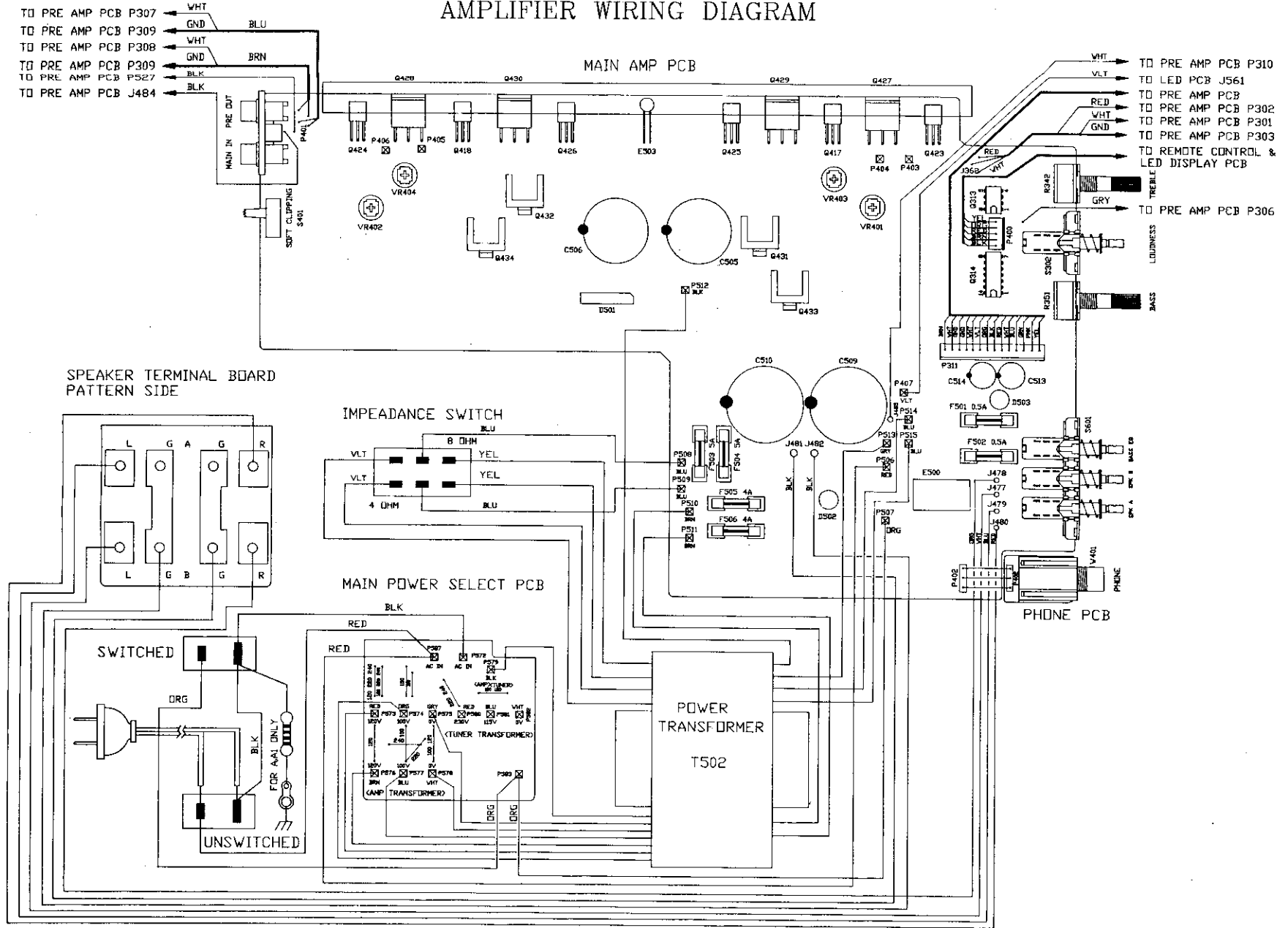

29

PRE AMP WIRING DIAGRAM

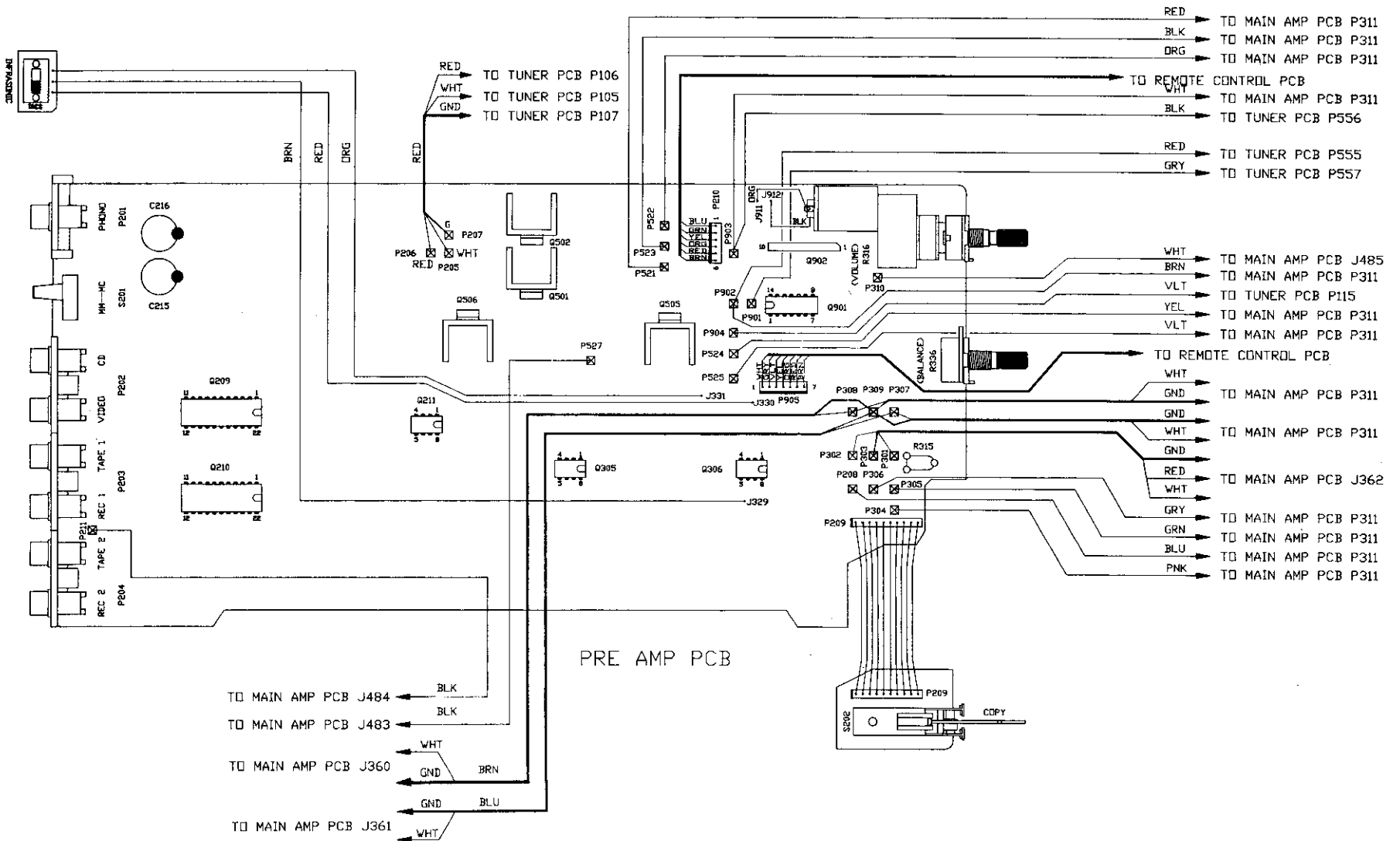

30

TUNER AND REMOTE/DISPLAY WIRING

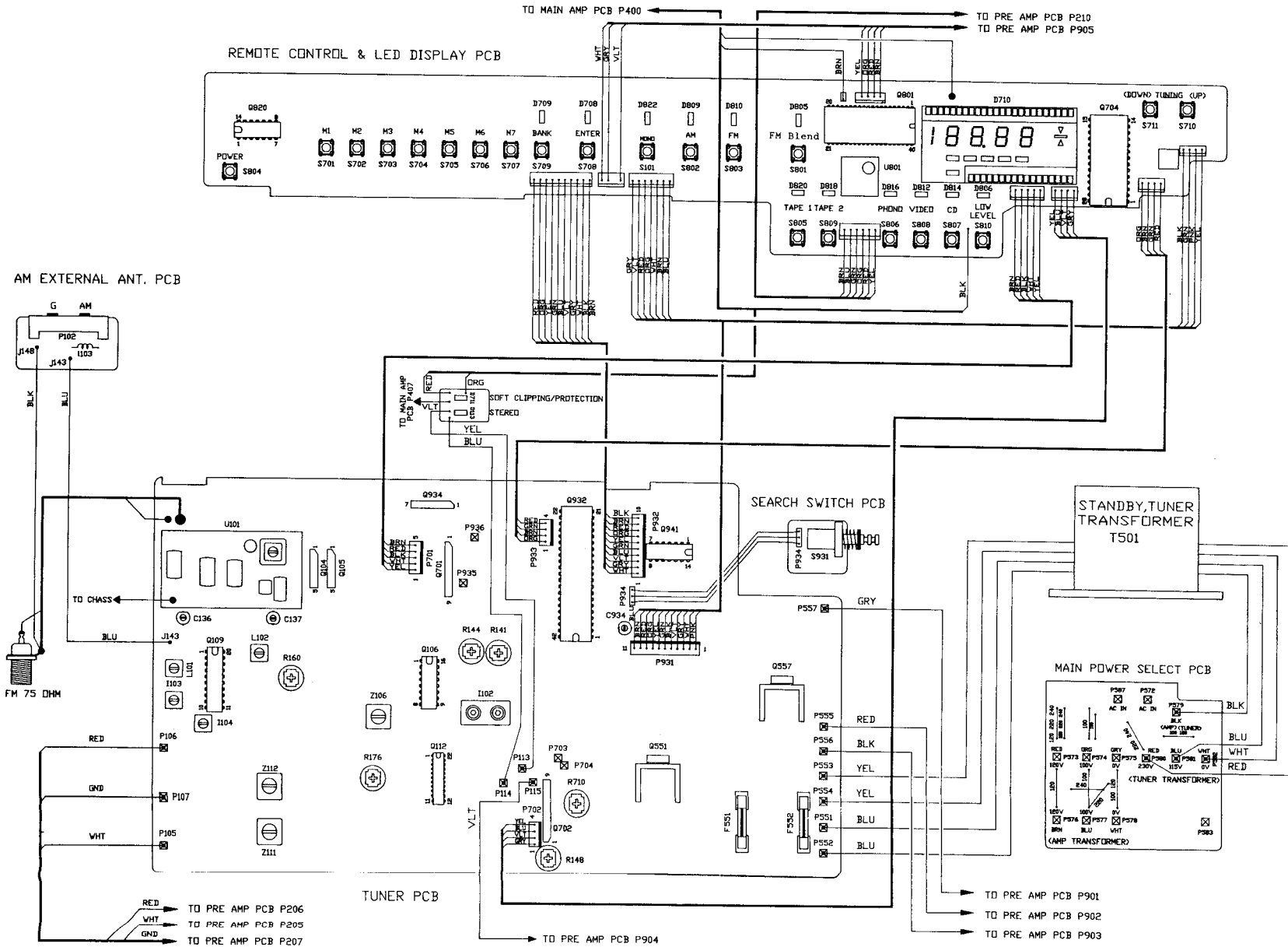

PARTS COMPARISON LIST (WITH MANY MODELS)

PART-NO.	DESCRIPTION	SPECIFICATION	UM	A	A1	B	B1	C	C1
5142427500	RESISTOR,CARBON FILM	RD SB 1/2W 2.7M	PC	1	1				
5142810390	RESISTOR,CARBON FILM	RD SB 1/4W 10K	PC	28	28	28	28	28	27
5142839390	RESISTOR,CARBON FILM	RD SB 1/4W 39K	PC	5	5	5	5	5	6
5145812406	RESISTOR,CARBON FILM	RD UB 1/4W 120K	PC	1	1	3	3	3	3
5145882306	RESISTOR,CARBON FILM	RD UB 1/4W 82K	PC	3	3	1	1	1	1
5226142100	CAPACITOR,POLYSTYRENE	CQ08S 50V 420PF	PC	1	1	3	3	3	3
5226191100	CAPACITOR,POLYSTYRENE	CQ08S 50V 910PF	PC	2	2				
5231822391	CAPACITOR,CERAMIC CK45	F DC 50V 22000PF	PC	39	39	39	39	39	38
5247068001	CAPACITOR,CERAMIC CC45	SL DC 50V 68PF	PC						3
5247127101	CAPACITOR,CERAMIC CC45	SL DC 50V 270PF	PC						4
5535203600	WARRANTY CARD	NAD-3220/7220	PC			1			
5535203700	WARRANTY CARD (A1)	NAD-3220/7220	PC		1				
5535444900	SPEC.LABEL	120V UL-1 A	PC	3					
5535444910	SPEC.LABEL	120V UL-1 A	PC		3				
5535444920	SPEC.LABEL	240V BS B	PC			3			
5535444930	SPEC.LABEL	240V SA-2 B1	PC				3		
5535444940	SPEC.LABEL	220V CEE-2 C	PC					3	
5535444950	SPEC.LABEL	220V CEE-2 C1	PC						3
5535447800	SAFETY INSTRUCTION	NAD-USA	PC		1				
5535448400	LIGHTNING LABEL	UL	PC		2				
5535450200	GERMAN POST OFFICE	NAD-SERIES	PC						1
5547033900	LUG	NAD-7100	PC	1	1				
5547131930	BACK PLATE (120V)	NAD-7000	PC	1	1				
5547131940	BACK PLATE (240V)	NAD-7000	PC			1	1		
5547131950	BACK PLATE (220V)	NAD-7000	PC					1	1
5547802120	FOOT	NAD-7100	PC	4		4	4	4	4
5547802121	RUBBER FOOT	NAD-7100(UL 94-V0)	PC		4				
5552102100	TUNER	FE407-A16	PC	1	1	1	1	1	
5552102110	TUNER	FE407-G25/R16/2879	PC						1
5552302800	ANT.ADAPTOR	2-U4010#01	PC	1	1				
5552302900	ANT.ADAPTOR	S-U5011#12	PC			1	1	1	1
5554306500	FUSE 5.2x20	T51 250V 500MA SEMKO	PC			4	4	4	4
5554306501	FUSE UL & CSA 5.2x20	250V 500ma	PC	4	4				
5554307400	FUSE 5.2x20	T51 250V 4.0A SEMKO	PC			2	2	2	2
5554307500	FUSE 5.2x20 5ST5	5A 250V SEMKO	PC			2	2	2	2
5554307501	FUSE UL & CSA 5.2x20	125V 5A MEDIUM BLOW	PC	2	2				
5554309800	FUSE UL & CSA 5.2x20	125V 4A MEDIUM BLOW	PC	2	2				
5556200800	LUG	3.1MM	PC	1	1				
5556205300	75 OHM ANT TERMINAL	12-1030	PC			1	1	1	1
5556205310	75 OHM ANT TERMINAL	12-1032	PC	1	1				
5556205421	SPEAKER TERMINAL	S0-6253	PC	2	2	2	2		2
5556205431	SPEAKER TERMINAL	S0-6254	PC					2	
5556308320	AC OUTLET (POLARIZED)	S-I6519-02#01/HJC-030	PC	2	2				
5556311400	AC SOCKET	S-16536#01	PC			1		1	1
5556312100	AC RECEPTACLE	S2-739T-100	PC				1		
5556400700	ANT. CONNECTOR	SH-756	PC			1	1	1	1
5556700131	AC POWER CORD W/PLUG B	PL-21 42/.15x2Cx1.8M	PC					1	1
5556701310	POWER CORD BLK GTBS-2F	24/0.2x2Cx2M(BS)	PC			1			
5556702011	AC POWER CORD W/PLUG B	SAA 42/0.15x2Cx1.8M	PC				1		
5556702121	POWER CORD W/PLUG SPT	AWG18# 41/0.16x2Cx2.1	PC	1	1				
5562001000	SPRING COIL	0.7x3x10TS	PC						1
5564401320	TRAP COIL	470 UH +-20%	PC						2
5564401330	TRAP COIL	22 UH +-20%	PC						2
5635410800	LABEL,SERIAL NO.	TV-19TD SYSTEM	PC		1				
6119210600	WIRE,TIN COATED SOFT C	0.6MM	M	16.52	16.52	16.46	16.46	16.46	16.22
6140071900	WIRE DOUBLE INSULATED	22AWG 17/0.16 UL1617	M			0.16	0.16	0.16	0.16
6140071922	WIRE DOUBLE INSULATED	22AWG 17/0.16 UL1617	M	0.4	0.4	0.5	0.5	0.5	0.5
6140071933	WIRE DOUBLE INSULATED	22AWG 17/0.16 UL1617	M	0.34	0.34	0.5	0.5	0.5	0.5
6176560600	WIRE PVC (COATING) UL	600V 5A 7/0.26 T=105	M	0.24	0.24				
6176560602	WIRE PVC (COATING) UL	600V 5A 7/0.26 T=105	M	0.23	0.23				
6176560603	WIRE PVC (COATING) UL	600V 5A 7/0.26 T=105	M	0.17	0.24				
6707020460	INSULATION TUBING PVC	600V T=105 AWG5 BLK	M	0.05	0.05				

VERSIONS CHART :

VERSION	VOLTAGE	COUNTRY
A	120 V	Canada.
A1	120 V	U.S.A.,Taiwen,Saudi Arabia.
A2	120 V/220 V Wire/With Adaptor	Germany Police.
B	240 V	U.K., South Africa.
B1	240 V	Australia.
C	220 V	Denmark, France, Thailand, Singapore, Finland, Greece, New Zealand, Norway, Hongkong, Israel,Netherlands, Sweden, Iceland, Italy, Switzerland, Spain.
C1	220 V	West Germany

NAD-7000
EXPLODED VIEW

36

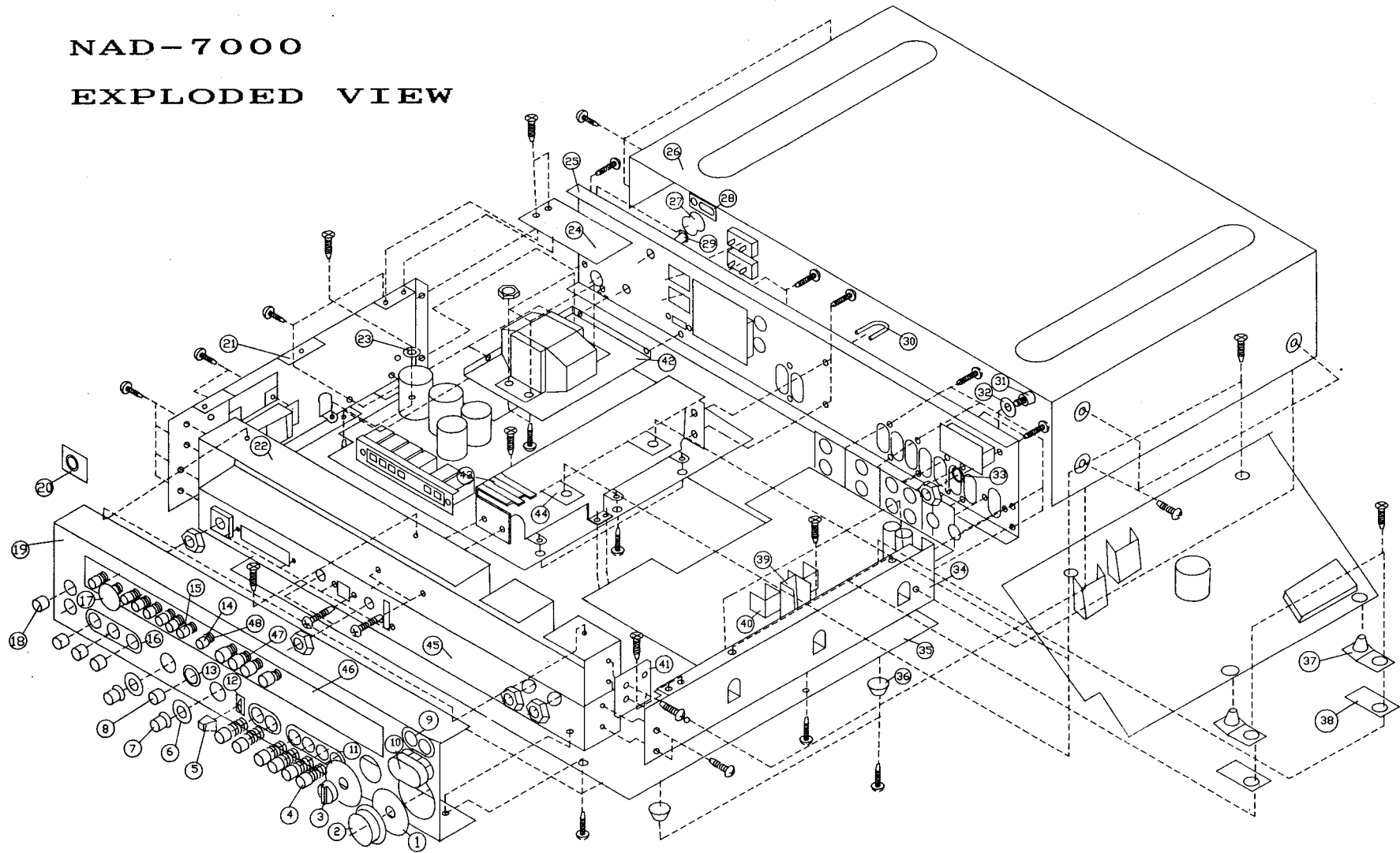

NAD-7000 EXPLODED PARTS LISTS

NO.	PARTS NAME	PARTS NO.
1	HEMELON (L)	5542006110
2	KNOB,VOLUME	5541537900
3	KNOB,BALANCE	5541538000
4	KNOB,BAND	5541537300
5	CAP,TOGGLE	5541537800
6	HEMELON (S)	5542006100
7	KNOB,CONTROL	5541537510
8	BUTTON,PUSH	5541537700
9	BEZEL,SCAN	5542225800
10	KNOB,SCAN	5541537600
11	BEZEL,FUNCTION	5542225300
12	BEZEL COPY	5542225200
13	BEZEL LOUDNESS	5542225000
14	KNOB,PUSH (R)	5541537110
15	KNOB,PUSH (B)	5541537100
16	BEZEL,SPEAKER	5542225100
17	LABEL,FRONT	5535448300
18	KNOB,POWER	5541537200
19	PANEL,FRONT	5541213110
20	BEZEL,POWER	5542225400
21	PLATE,LEFT	5547131600
22	BRACKET,FRONT (B)	5547132000
23	FIBER	5547504600
24	SHIELD COVER	5545403700
25	PLATE,BACK	5547131930(120V) 5547131940(240V) 5547131950(220V)
26	COVER, TOP	5541002300
27	CORD,POWER	5547501200
28	LOCK PLATE,SWITCH	5547528400
29	SUPPORT,PCB	5547530400
30	CONNECTOR,TERMINAL	5547033600
31	TERMINAL	5546121400
32	WASHER,TOOTH	7101200352
33	WASHER,LOCK	7101201202
34	PLATE,RIGHT	5547131700
35	CHASSIS	5547131800
36	FOOT,RUBBER	5547802120
37	HING	5419700191
38	PLATE,AUX	5547035800
39	HEAT SINK (S)	5545306900
40	HEAT SINK (S)	5545306910
41	BRACKET PLATE,RIGHT	5547033800
42	PLATE,TRS.	5547131100
43	HEAT SINK	5545308900
44	HOLDER	5547038500
45	BRACKET,FRONT (A)	5547131500
46	WINDOW,RECEIVE	5542909410
47	SPRING,PLAY (A)	5546323000
48	SPRING,PUSH	5546322900

PACKING DIAGRAM

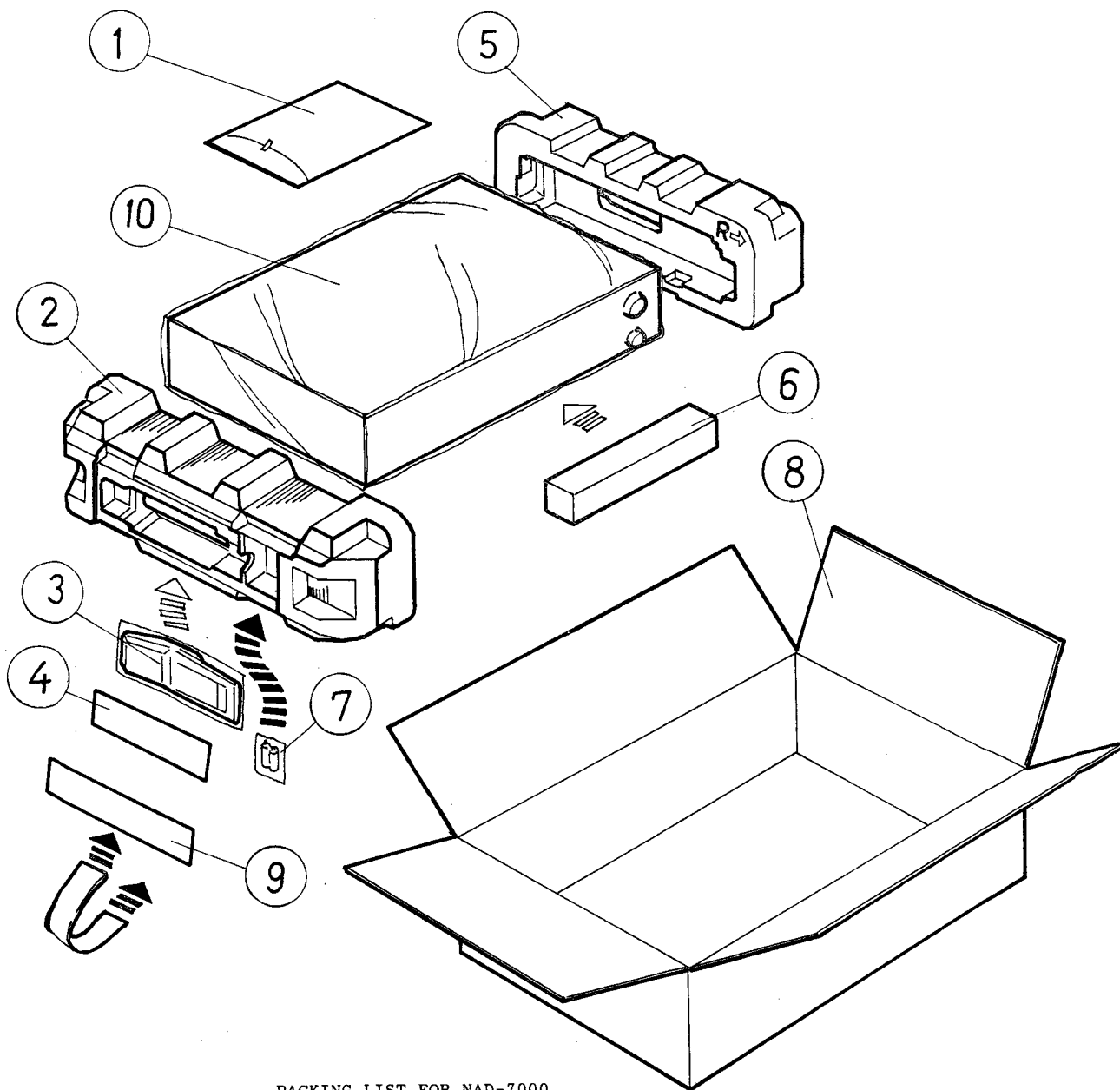

PACKING LIST FOR NAD-7000

ITEM	PARTS NO.	NAME	QTY
1	5535122513	OWNERS MANUAL	1
2	9520680155	POLYLON L.	1
3	5552000200	REMOTE CONTROL TRANSMITTER	1
4	- - - - -	R/C TRABSNOTTER MANUAL	1
5	9520680255	POLYLON R.	1
6	9520685155	POLYLON BAR	1
7	6910151403	BATTER, DRY	1
8	9510680455	CARTON	1
9	9510685155	PAPER PLATE	1
10	9530680155	EPE BAG	1

Notes:

NAD Electronics Ltd.

Model : 7000

Service Information

Issue 1

Date : 22 November 1989

Contact ;

Electronic Field Engineering Centre

de Baan 6

5095 EB Hooge-Mierde

Netherlands

Tel.(31) 4259-2533 ; Fax (31) 4259-1590

Proprietary information for servicing purposes only. The information given herein may not be used commercially without the prior written agreement of NAD Electronics Ltd, Adastra House, 401-405 Nether Street, London, N2 1QG, England.

SERVICE MANUAL

7000
RECEIVER

© 1988 BY NAD 548 PRINTED IN TAIWAN R.O.C.

NAD ELECTRONICS
BOSTON/LONDON