

NAD **SERVICE**
MANUAL

6325
CASSETTE DECK

PAGE	CONTENTS
2	Specification
3	Rear/Front View
4	Alignment Method
6	Block Diagram
7	Wiring Diagram
9	Schematic, Full
13	Schematics and PCB Layouts
19	Parts Lists and Exploded Views

SPECIFICATION

Cassette mechanism: Full logic 2 motor 2 head system		Nominal	Limit	Unit
Track system: 4-track, 2-channel stereo		Separation (with 1 kHz B.P.F) REC/PLAY		
		Dolby level input at 1 kHz	40	35
		Cross talk at 1 kHz (with 1 kHz B.P.F)		
		0 VU + 10 dB input	70	65
		Output level at Dolby level		
		MTT-150 PLAY	505	505 ± 1 dB
		Distortion (at Dolby level 1 kHz)		
		TYPE I	1.0	2.0
		TYPE II	2.2	2.9
		TYPE IV	2.2	2.9
		Compress effect (boost ratio) at Dolby level -40 dB		
		30 Hz	+18	+16/+20
		1 kHz	+12	+10/+14
		15 kHz	+15	+13/+17
		Nominal	Limit	Unit
Input sens./impedance (to Dolby level)		40 ± 1 dB/10		mV/kΩ
Frequency response PLAYBACK		40~12.5k		Hz
Frequency response REC/PLAY (at Dolby level -25 dB, Dolby NR:OFF)				
TYPE I		35~14k		Hz
TYPE II		35~15k		Hz
TYPE IV		35~15k		Hz
Signal to noise ratio at Dolby level, Dolby NR:OFF (CCIR ARM weighted / 20~20k Hz B.P.F)				
TYPE I No tape		59/52	56/49	dB
Virgin tape		54/51	52/48	dB
Biased tape		50/49	48/46	dB
TYPE II,IV No tape		63/54	59/51	dB
Virgin tape		58/53	54/50	dB
Biased tape		52/50	50/48	dB
Dolby NR effect (CCIR ARM at Dolby level)				
Dolby NRB		9	8.5	dB
Dolby NRC		18	17	dB
Erase effect (with 1 kHz B.P.F)				
0 VU + 10 dB input		70	65	dB
		Power supply 120 V 60 Hz (for A,A1,A2)		
		220~240 V 50 Hz (for B,B1,C,C1,C2)		
		Power consumption 22(0.2) W(A)		
		Dimensions(W/D/H) (include knob and leg) 420/271/122 mm		
		Net weight 4.3 kg		
		The specifications are subject to change without prior notice.		
		A : USA		
		A1 : CANADA		
		A2 : TAIWAN		
		B : U.K.		
		B1 : AUSTRALIA/N.Z.		
		C : EUROPE & OTHERS		
		C1 : W.GERMANY		
		C2 : G.P.M.		

REAR PANEL

1. AC Power Cord.
2. Output.
3. Input.

ATTENTION:

ATTENTION: RISK OF ELECTRIC SHOCK TO THE USER.
 ET LES CONSÉQUENCES GRAVES QUI POURRAIENT EN RÉSULTER. NE TENTEZ PAS D'OUVRIR L'APPAREIL ET DE TOUCHER AUX COMPOSANTS INTERNES SANS LA PRÉSENCE D'UNE PERSONNE QUALIFIÉE.

CAUTION

CAUTION: TO REDUCE THE RISK OF ELECTRIC SHOCK, DO NOT REMOVE COVER (OR BACK). NO USER SERVICEABLE PARTS INSIDE. REFER SERVICING TO QUALIFIED SERVICE PERSONNEL.

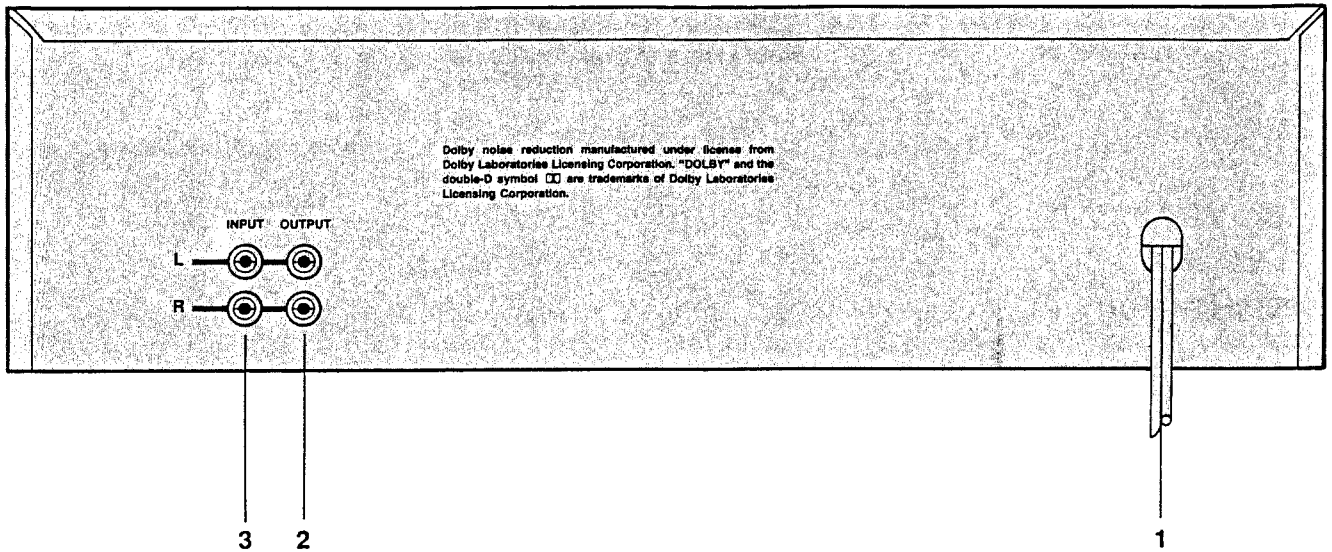

FRONT PANEL

- | | | |
|--------------------------|----------------------------|---|
| 1. Power. | 7. Rewind (◀◀). | 13. Tape Selector. (Normal/CrO ₂ /Metal) |
| 2. Open. | 8. Fast Forward (▶▶). | 14. Recording Level. |
| 3. Cassette Compartment. | 9. Record. | 15. Recording Level Display. |
| 4. Play. | 10. CAR Processor. | 16. Tape Counter. |
| 5. Pause. | 11. Dolby [®] NR. | 17. Re-set. |
| 6. Stop. | 12. Play Trim. | |

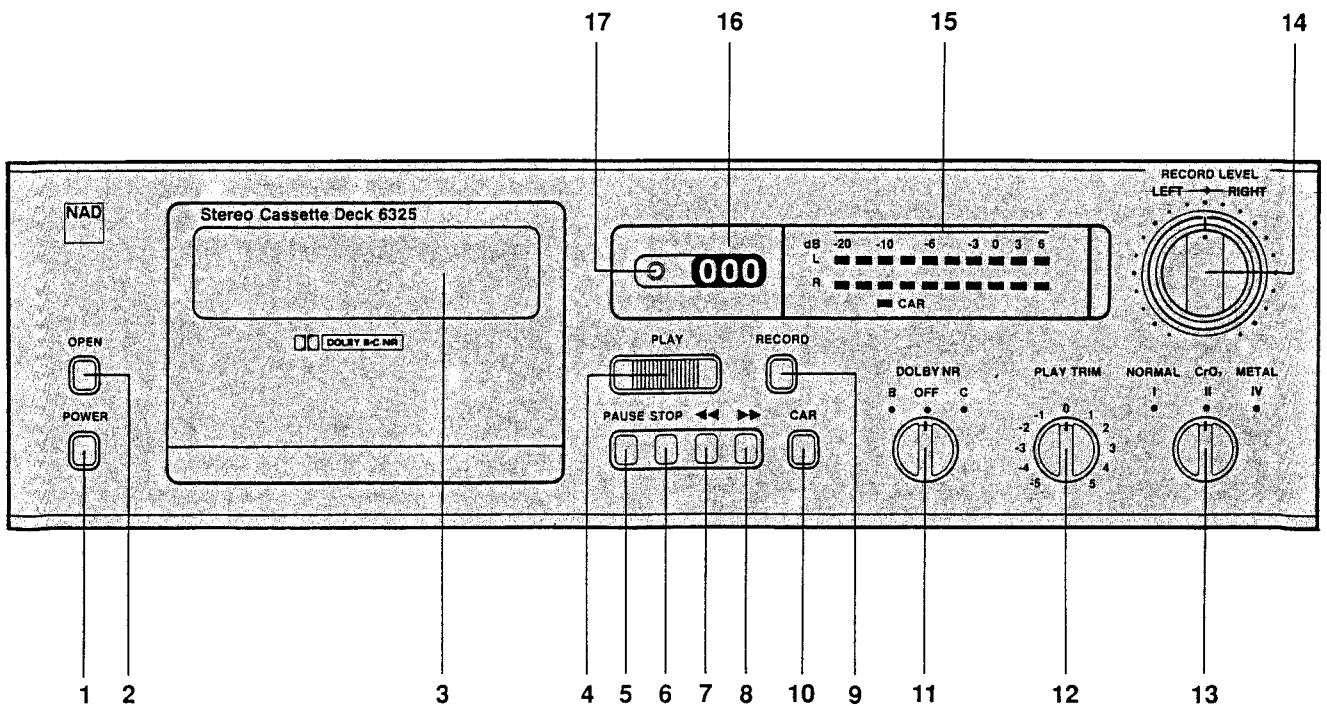

ALIGNMENT METHOD

IMPORTANT

The tape path (heads, tape guides, capstan, pinch roller) should be cleaned and degaussed before alignment.

This tape recorder is designed to work well with a variety of tapes, however, maximum performance will be obtained with recommended tapes or similar tape formulations.

Recommended tapes	For North America	For Europe-DIN
Type I	Maxell UDS-I	Maxell UD-I, BASF TP18 no, R723DG
Type II	Maxell XL-II	Maxell XL-II, Teac MTT-5561, BASF, U564W
Type IV	Maxell MX	Maxell MX, Maxell MX 422

Before adjusting, switch DOLBY NR, CAR off; and PLAY TRIM, to center position.

DOLBY NR level 200 nWb/m = 245 mV RMS on testpoints TP003 (PLAYBACK and RECORDING) on Main PCB; approximately 505 mV at line outputs.

1. TAPE SPEED

Connect one output to Wow and Flutter Meter or Frequency Counter, Play speed test tape TEAC MTT-111 = 3 kHz or TEAC MTT-211 = 3.15 kHz and adjust the semi-variable resistor, for correct reading on Wow and Flutter Meter or Frequency Counter. (See Fig. A)

Tolerance: $\pm 1\%$

2. AZIMUTH

Connect VTVM's and/or Oscilloscope to outputs. Set tape selector to normal and start playing Azimuth tape TEAC MTT-113 or MTT-114. Rotate azimuth screw for maximum output and/or maximum and in phase on Oscilloscope. Reseal adjustment screw with nail polish or similar (do not use glue). (See Fig. B)

3. PLAYBACK HIGH FREQUENCY EQ

THIS ADJUSTMENT SHOULD BE DONE ONLY WHEN HEAD HAS BEEN REPLACED.

Play frequency response tape TEAC MTT-256 or MTT-256U and check playback level at 14 kHz.

Before adjust, cut the center of jumper leads E001(L) and E002(R). Adjust by disconnecting E003(L) and E004(R) if 14 kHz is too high and connecting E001(L) and E002(R) if 14 kHz is too low. Leave same component values in both channels.

Tolerance: $+1.5$ dB
 -0.5

4. PLAYBACK LEVEL

Connect VTVM to testpoints. Play Dolby NR level tape TEAC MTT-150 and adjust SVR003(L) and SVR004(R) for 245 mV RMS at testpoint TP003 on Main PCB.

Tolerance: ± 2.5 mV RMS

Output should be approximately 505 mV RMS.

5. BIAS TRAP

Insert a blank type I tape and start recording. Turn record level all the way down and set tape selector to type IV position. Connect VTVM's and/or oscilloscope probe to testpoint TP201 and adjust F201(L) and F202(R) for minimum.

Tolerance: Less than 300 mV RMS.

6. RECORD LEVEL

Set tape selector to type I tape. Connect audio oscillator to line inputs, turn record levels to maximum (clockwise). Adjust audio oscillator frequency to 400 Hz and output so that VTVM's read 30-40 mV. (Use a convenient reference point on the VTVM's).

Reset tape counter to 0 and release pause to start recording. Record for approximately 5 seconds, rewind to 0 on tape counter and play back while observing the VTVM's. The VTVM's should indicate the same level as when the tape was recorded. Adjust SVR201(L) and SVR202(R) if necessary and repeat the record / play procedure until the readings are the same.

Tolerance: ± 0.5 dB from record level. Less than 0.5 dB difference between channels.

7. BIAS ADJUST TYPE I TAPE (NORMAL)

Set audio generator to 1.2 kHz without changing output level. Reset tape counter to 0 and start recording. After 5 seconds change audio generator frequency to 12 kHz (do not stop the machine or change levels) and continue recording for another 5 seconds. Stop and rewind to 0 on tape counter. Play back while observing VTVM's. There should be no level difference between the 1.2 kHz and the 12 kHz tone when played back. If 12 kHz is different in level for 1.2 kHz, adjust SVR301(L) and SVR302(R) and repeat the record / play procedure until both frequencies play back at same level.

Tolerance: ± 0.5 dB

WARNING: Greater tolerance will grossly affect the Dolby NR tracking and especially the Dolby C tracking.

Record level (step 6) should be checked and if necessary adjusted.

8. FREQUENCY RESPONSE TYPE II TAPE (CrO₂)

Insert a type II tape and set selector to type II position. Adjust audio generator to 1.2 kHz and 12 kHz and repeat process described in step 7 using SVR303 to adjust both channels simultaneously.

9. FREQUENCY RESPONSE TYPE IV TAPE (METAL)

Insert a type IV tape and set selector to type IV position. Repeat procedure as in step 8 while adjusting SVR304.

10. CAR

Engage record and pause mode. Adjust audio generator to 1 kHz and output so that voltage at TP003 is 24 mV. Switch CAR on, adjust SVR101(L) and SVR102(R) to increase 5 dB at TP003.

ALIGNMENT COMPONENTS LAYOUT

Fig. A FOR ADJUSTING TAPE SPEED

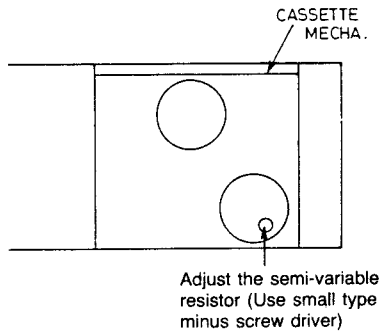

Fig. B FOR ADJUSTING AZIMUTH

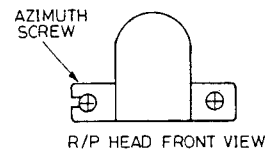
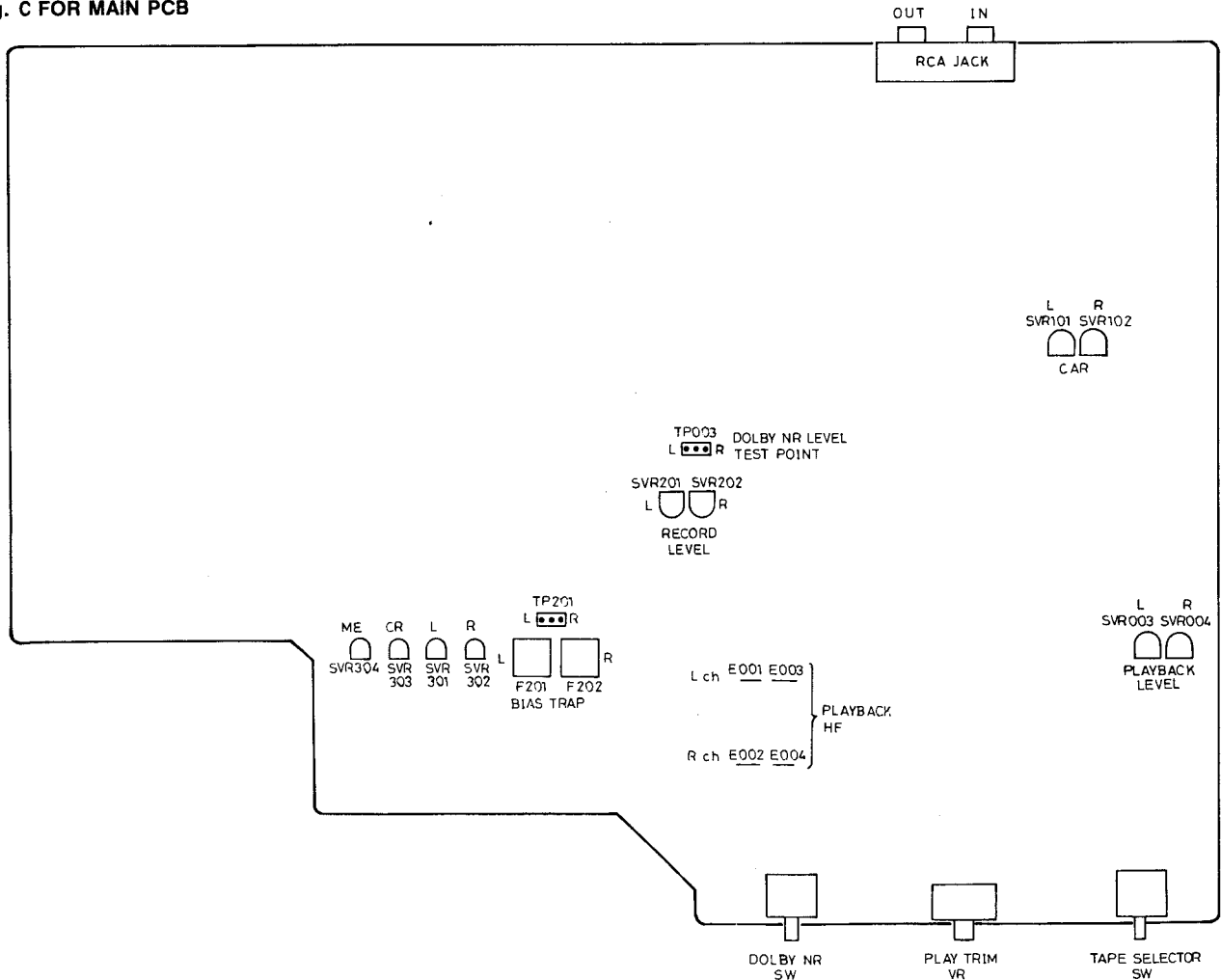
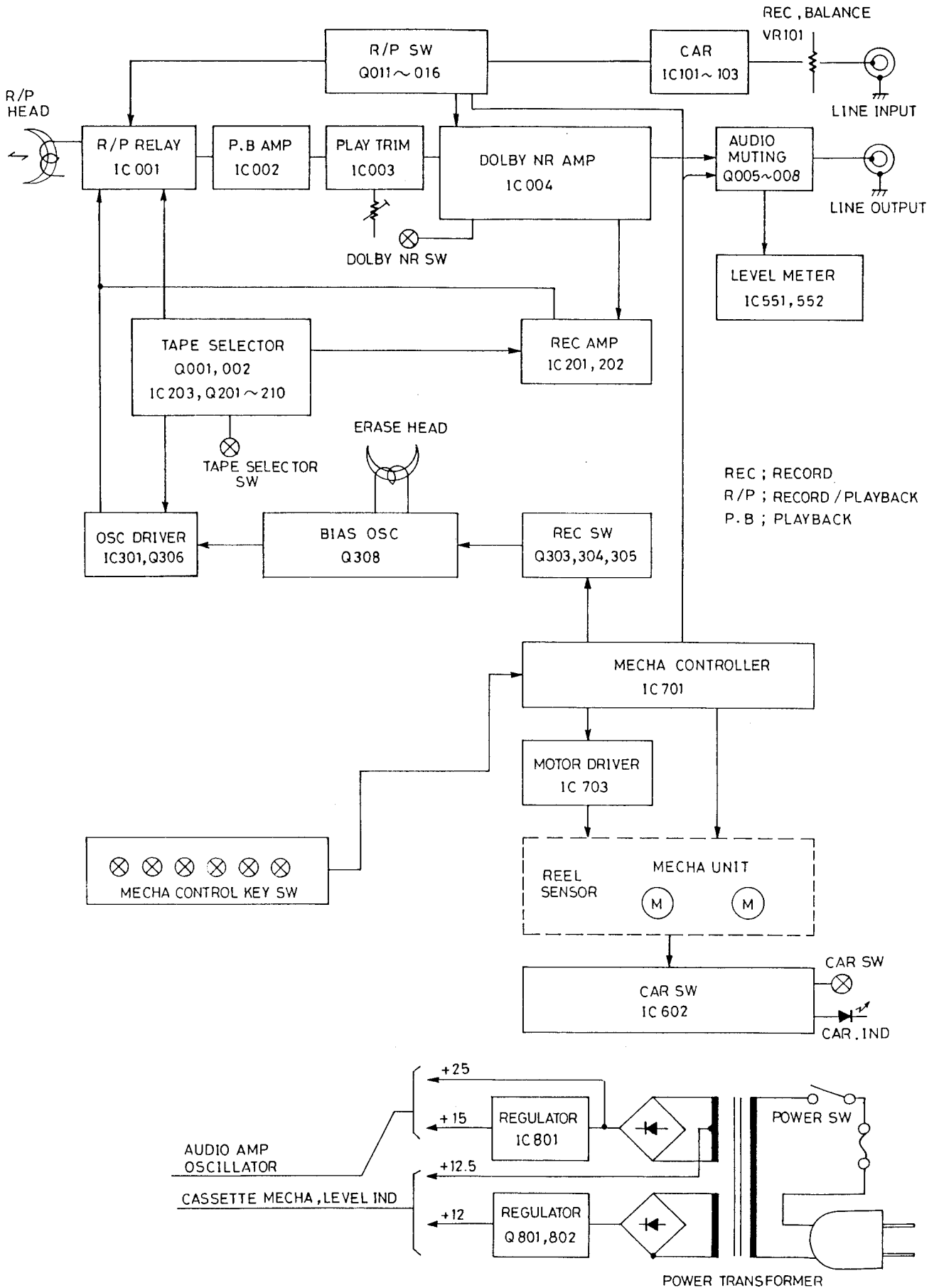

Fig. C FOR MAIN PCB



BLOCK DIAGRAM



WIRING DIAGRAM (Component side)

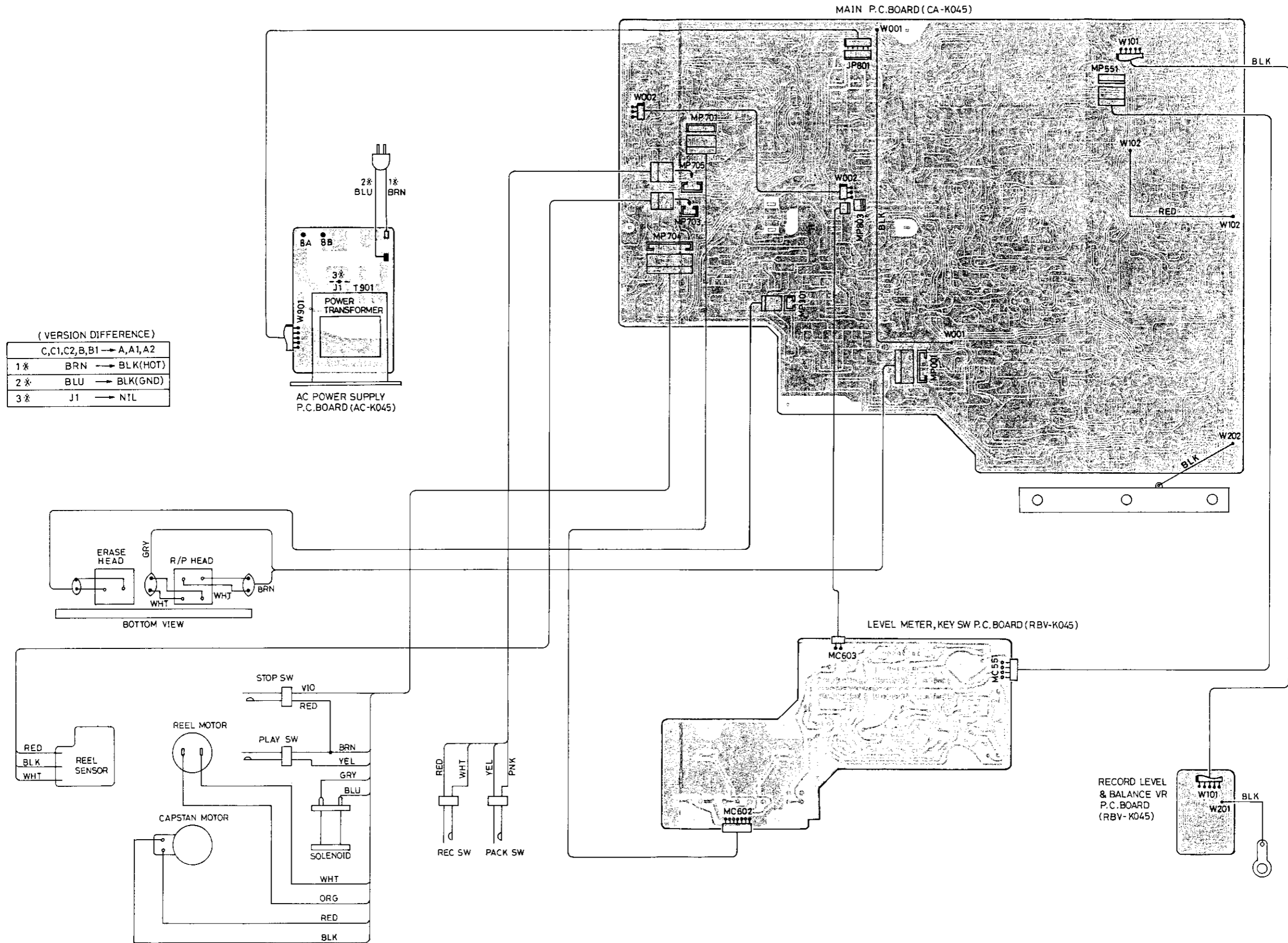

SCHEMATIC DIAGRAM

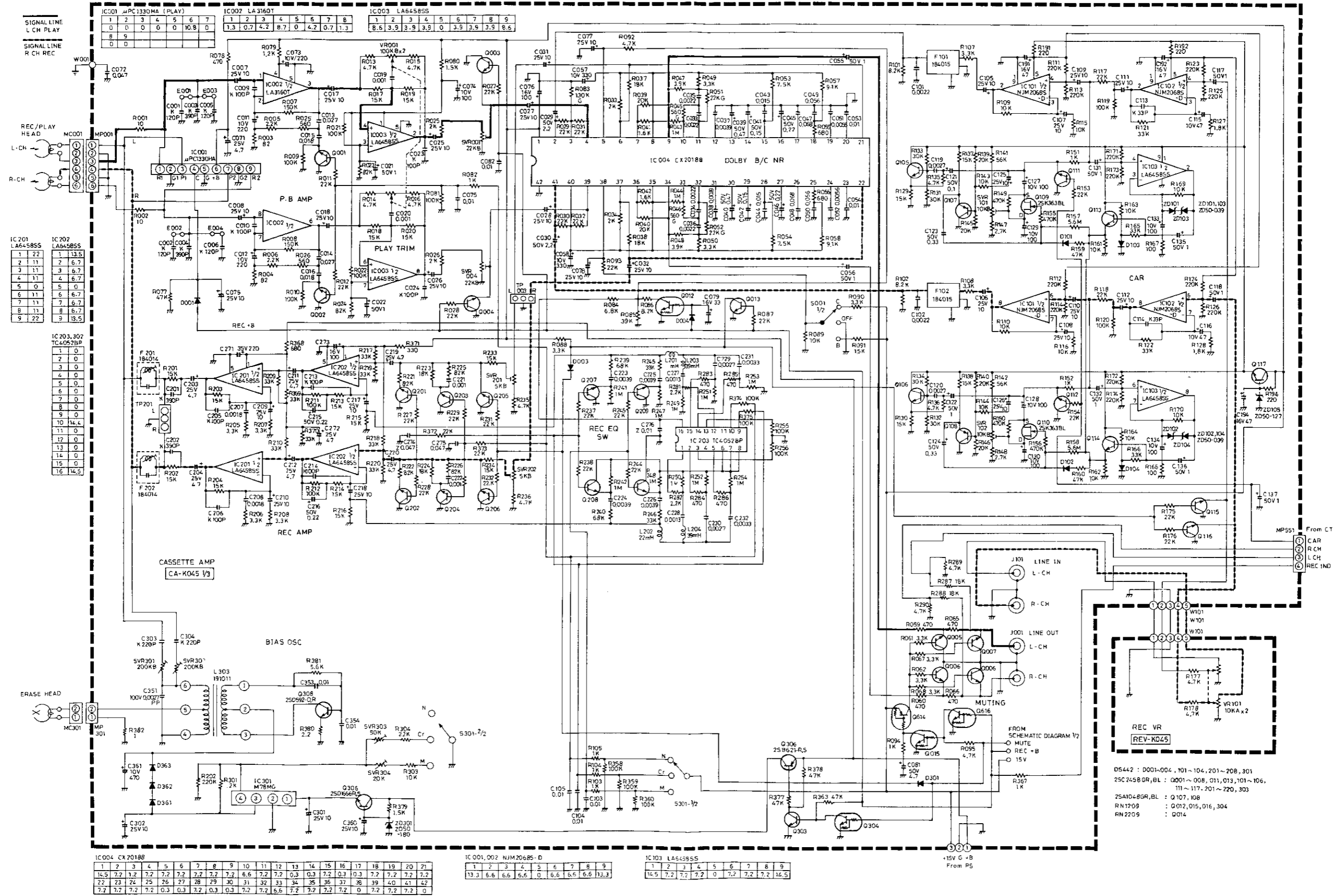

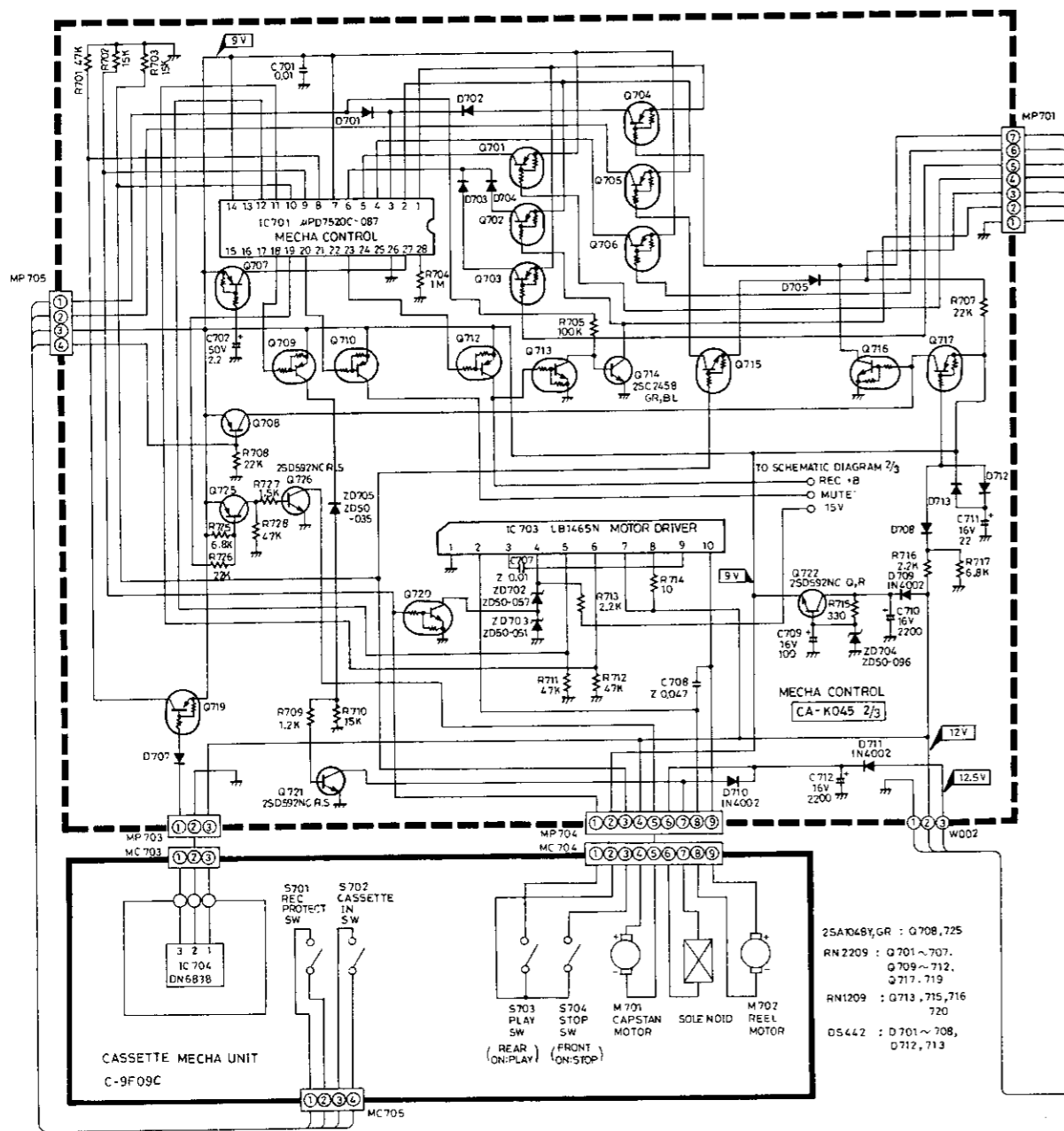

IC701 μ PD7520C-087

1	2	3	4	5	6	7	8	9	10	11	12	13	14
8.6	0.6	0	0	0	0	9.7	0	0	9.2	0	0	0	9.2
15	16	17	18	19	20	21	22	23	24	25	26	27	28
0	0	0	9.2	9.2	2.1	9.2	9.2	9.2	9.2	0	0	0	7.0

IC703 LB1465N

1	2	3	4	5	6	7	8	9	10
0	0	0.6	0	9	0	0	12	7.5	0.6

NOTE: VOLTAGE MEASUREMENT TAKEN WITH A HIGH IMPEDANCE VOLTMETER

WARNING:
Parts marked with the symbol Δ have critical characteristics.
Use ONLY replacement parts recommended by the manufacturer.

CAUTION:
Before returning the unit to the customer, make sure you make either (1) a leakage current check or (2) a line to chassis resistance check. If the leakage current exceeds 0.5 milliamp, or if the resistance from chassis to either side of the power cord is less than 500K ohms, the unit is defective.

WARNING - DO NOT return the unit to the customer until the problem is located and corrected.

TOLERANCE AND UNIT:

- CAPACITOR
- $\pm 20\%$ (μ F)
 - $\pm 5\%$ (μ F) - NOT Specify
 - K30% (μ F)
 - N30% (μ F)
 - Z+80% (μ F)
 - -20% (μ F)
- RESISTOR
- $\pm 5\%$ (Ω) 1/4W AND 1/2W - NOT Specify
 - $\pm 2\%$ (Ω) 1/4W

IC602 TC4013BP (CAR: OFF)

1	2	3	4	5	6	7	8
12	0	0	0	0	0	0	0
9	10	11	12	13	14		
0	0	0	0	12	12		

IC551, 552 LB1408

1	2	3	4	5	6	7	8	9	10	11
0	0	12	5	1	11	11	-	0.5	11	11
12	13	14	15	16						
11	11	11	0	0						

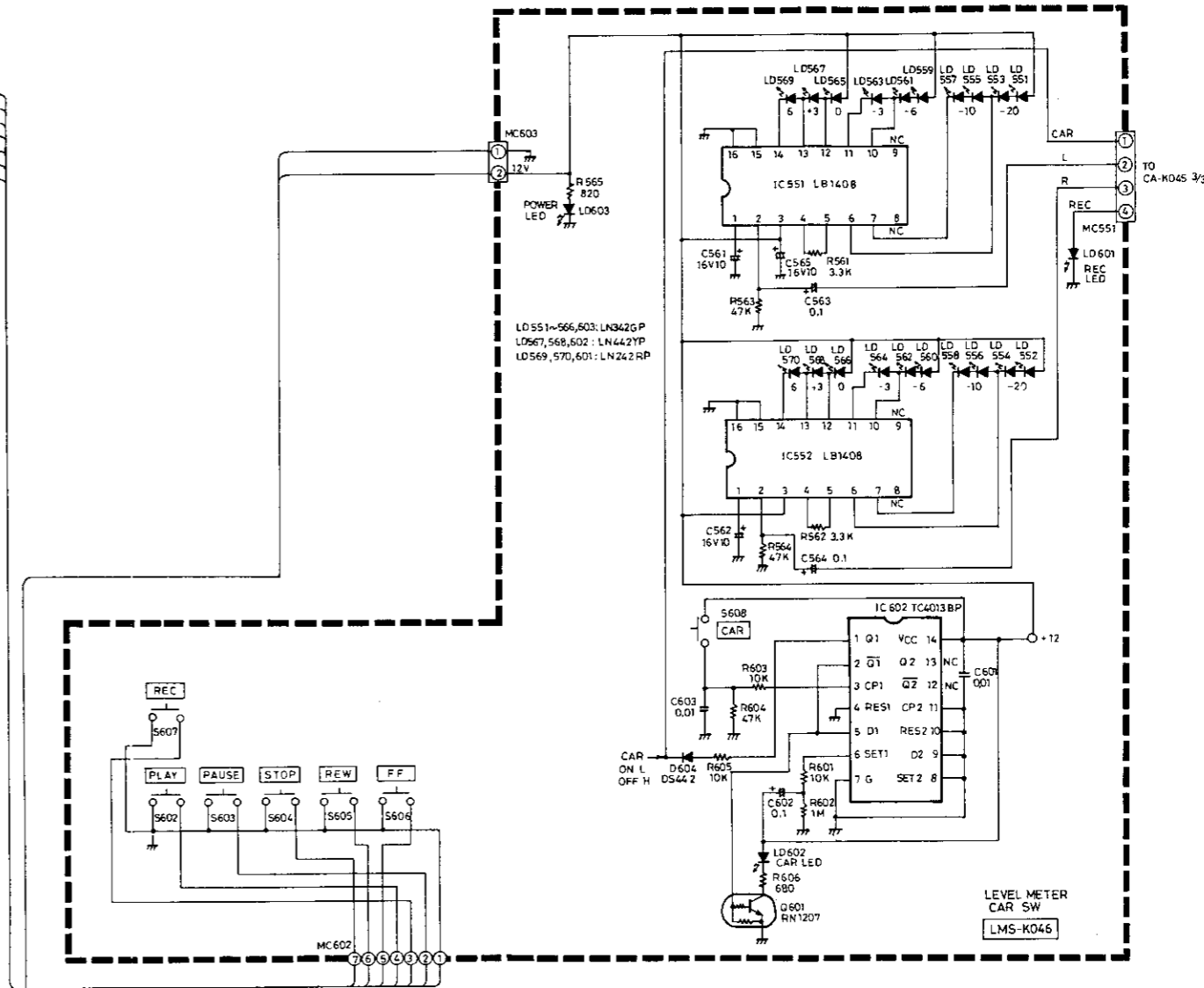

120V AREA
T901: NPT-K0154
FU802 ~ 804: NIL

TP901
220V 240V AREA
T901: NPT-K0155
FU802 ~ 804: T630mA

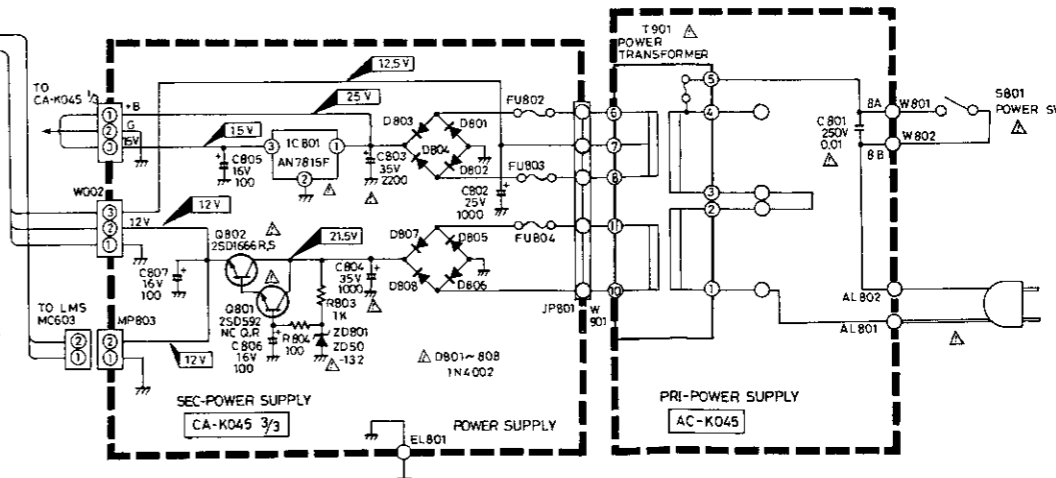

SCHEMATIC AND PCB LAYOUT (Foil side)
Main (CA-PCB)

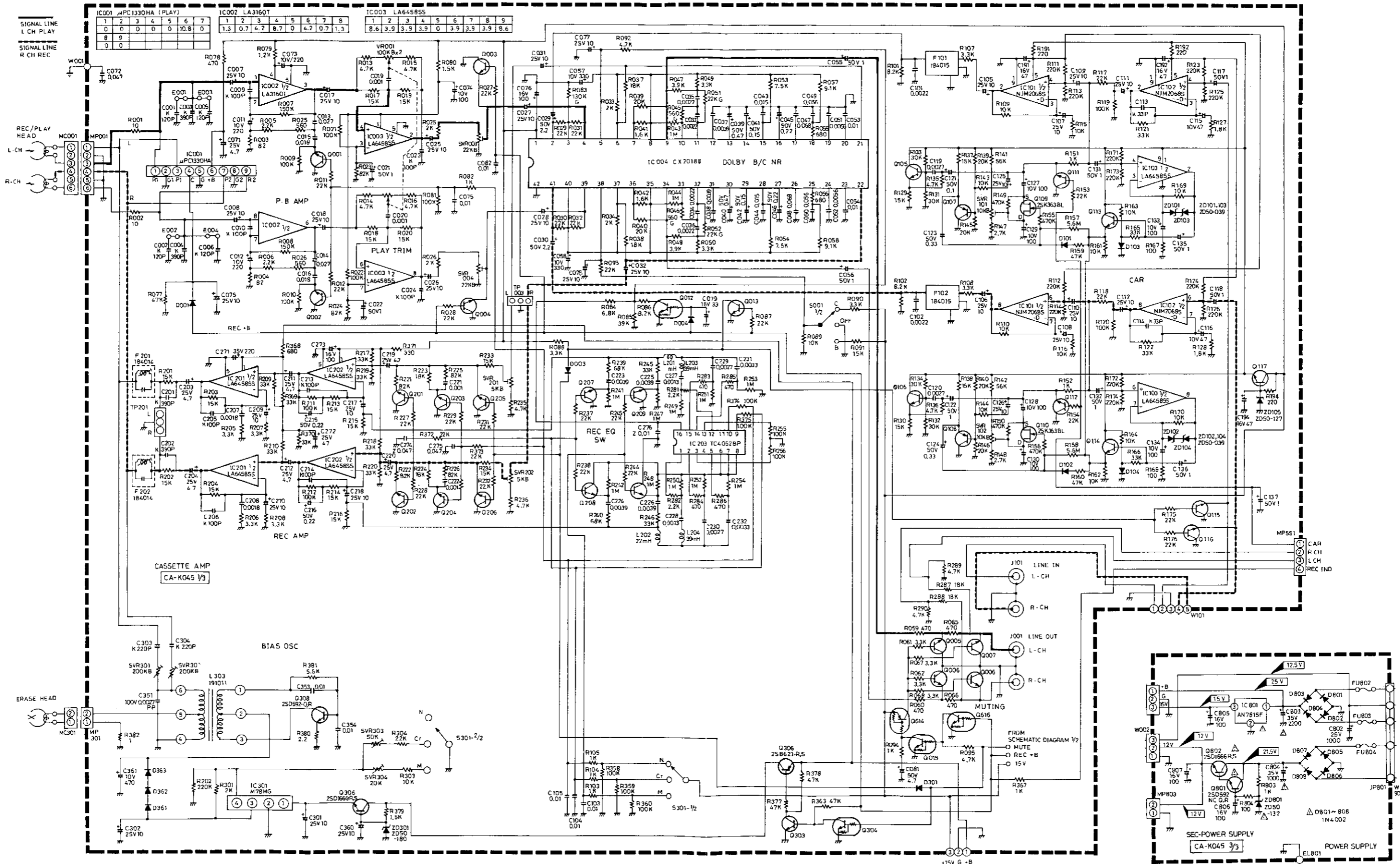

Rec. & Balance (RBV-PCB)

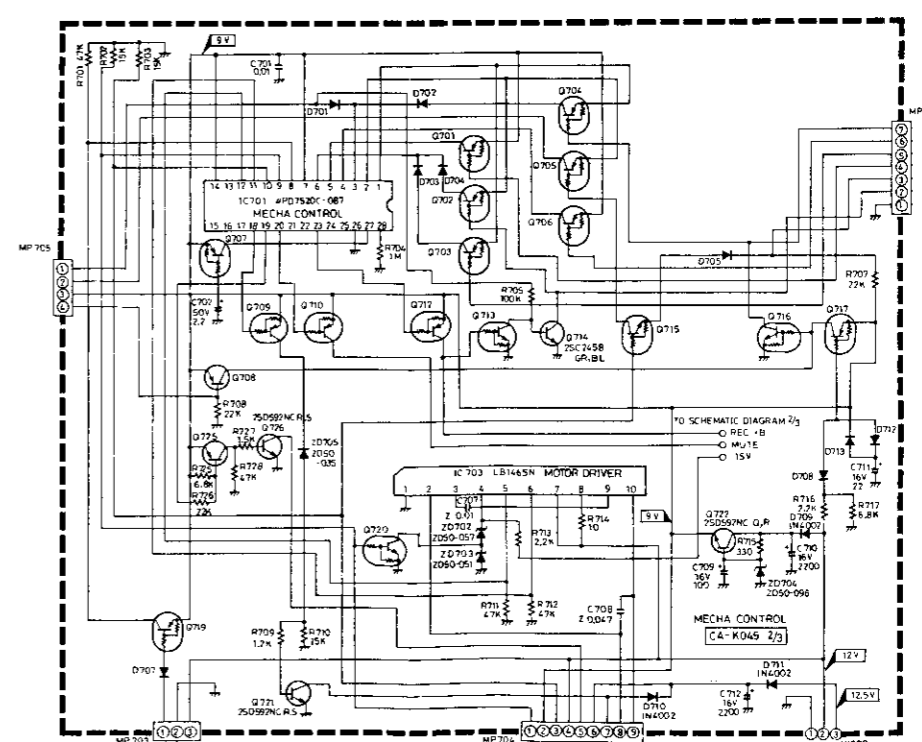
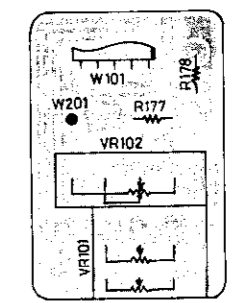
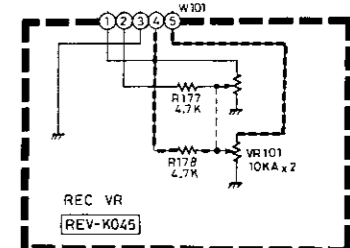
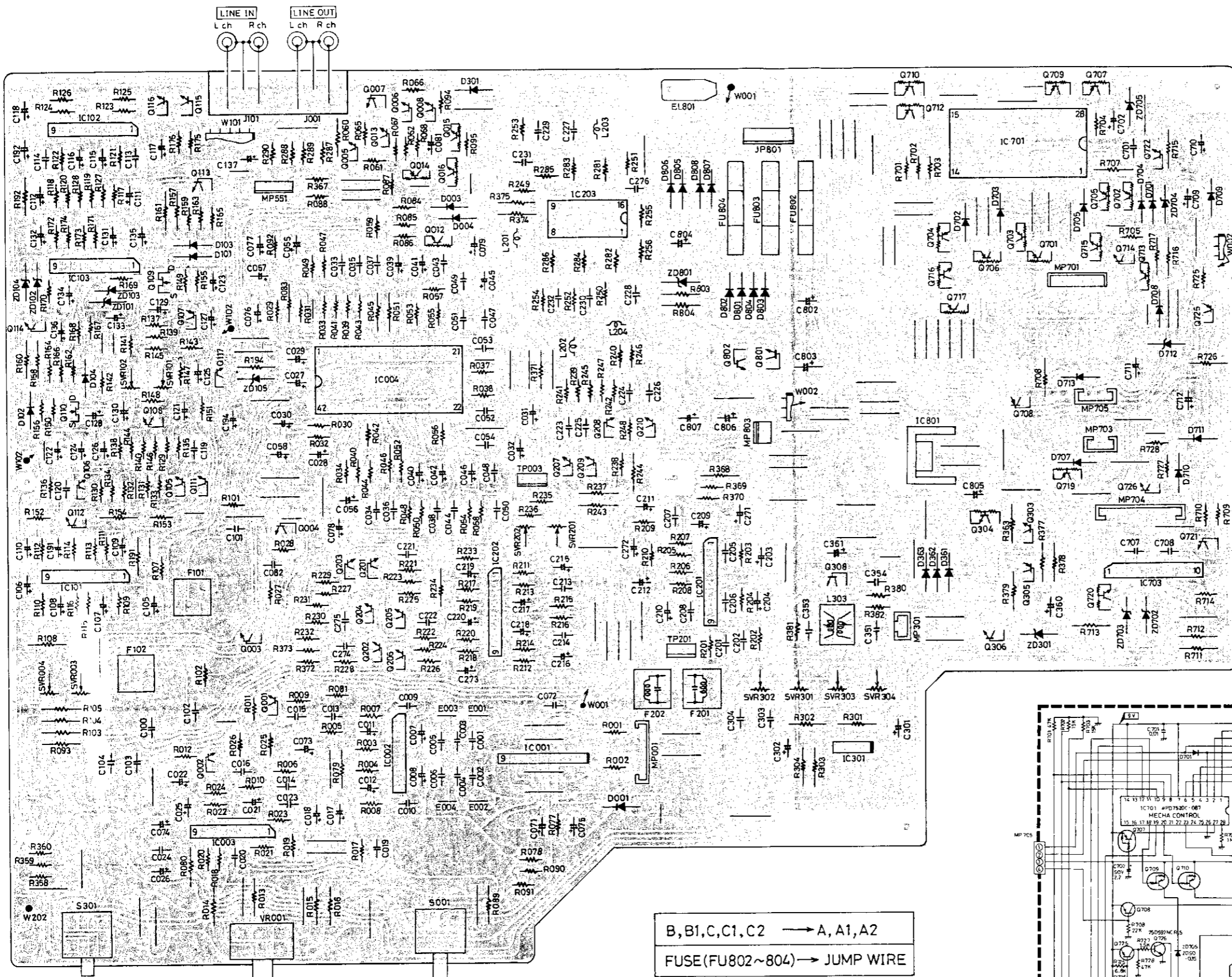

SCHEMATIC AND PCB LAYOUT (Foil side)
AC Power Supply (AC-PCB)

(For A, A1, A2 Version)

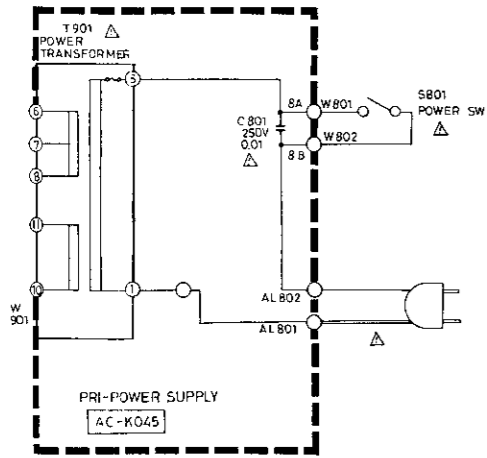

(For B, B1, C, C1, C2 Version)

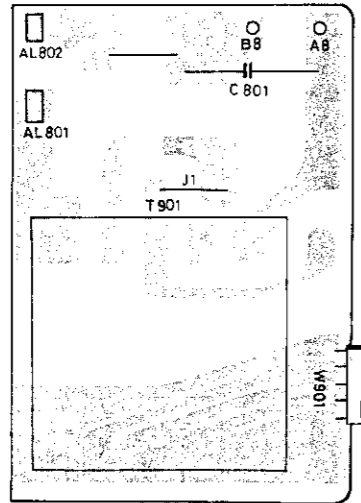
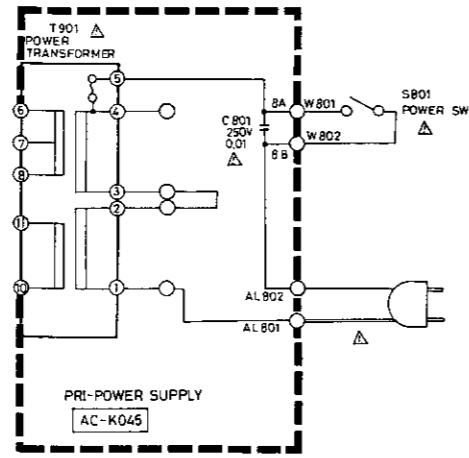

B, B1, C, C1, C2 → A, A1, A2
 JUMP WIRE (J1) → NIL

SCHEMATIC AND PCB LAYOUT (Foil side)
Level Meter, Key SW (LMS-PCB)

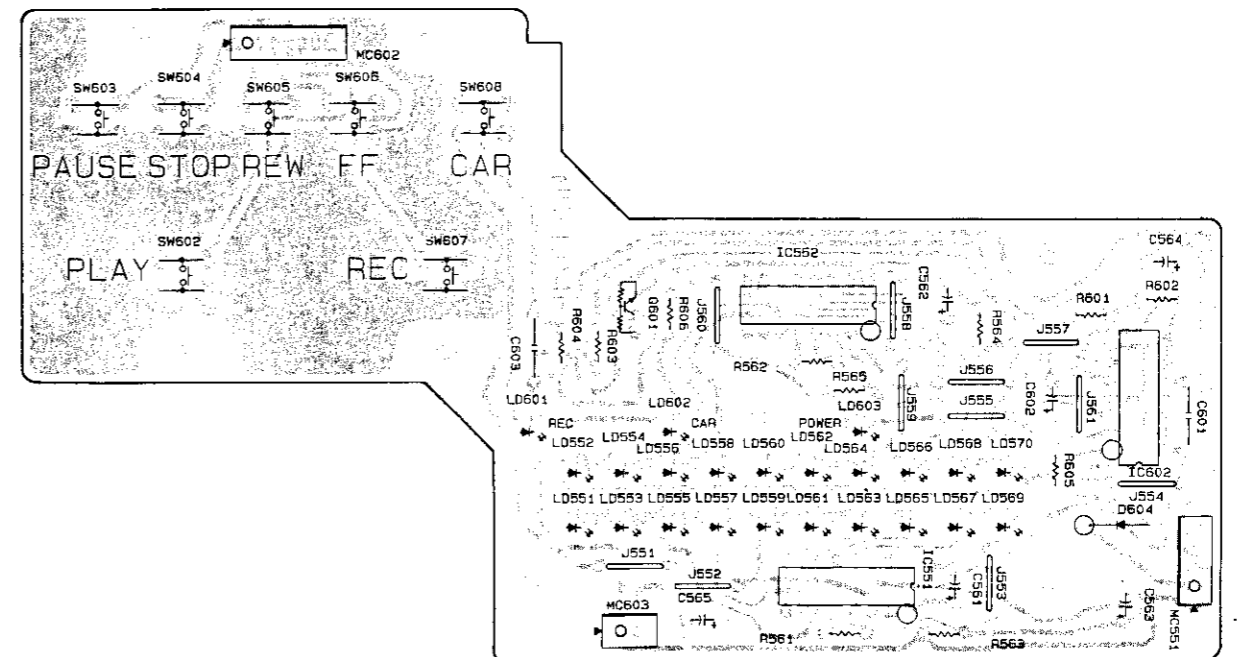
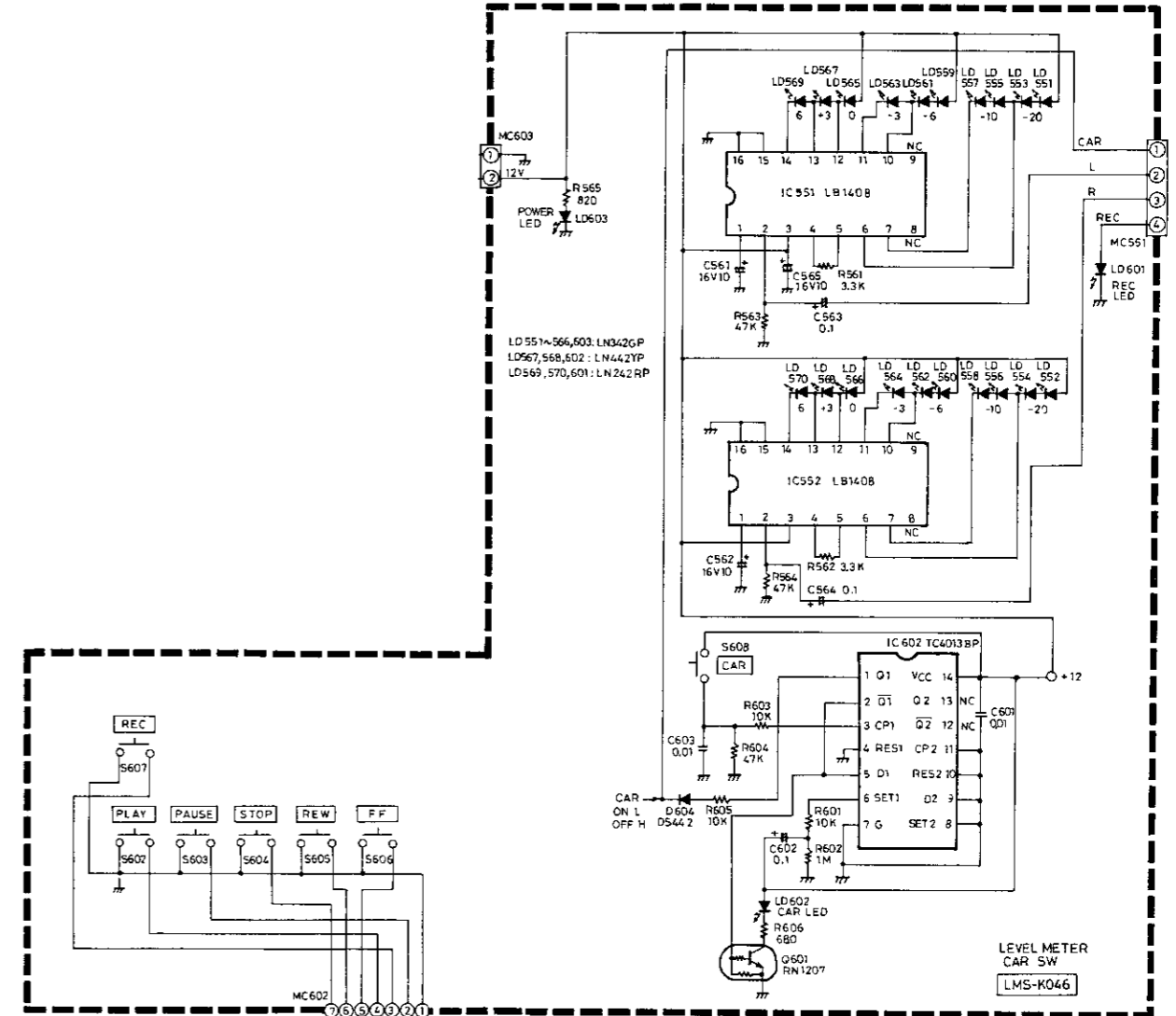

EXPLODED VIEW AND PARTS LIST
Cassette Mechanism

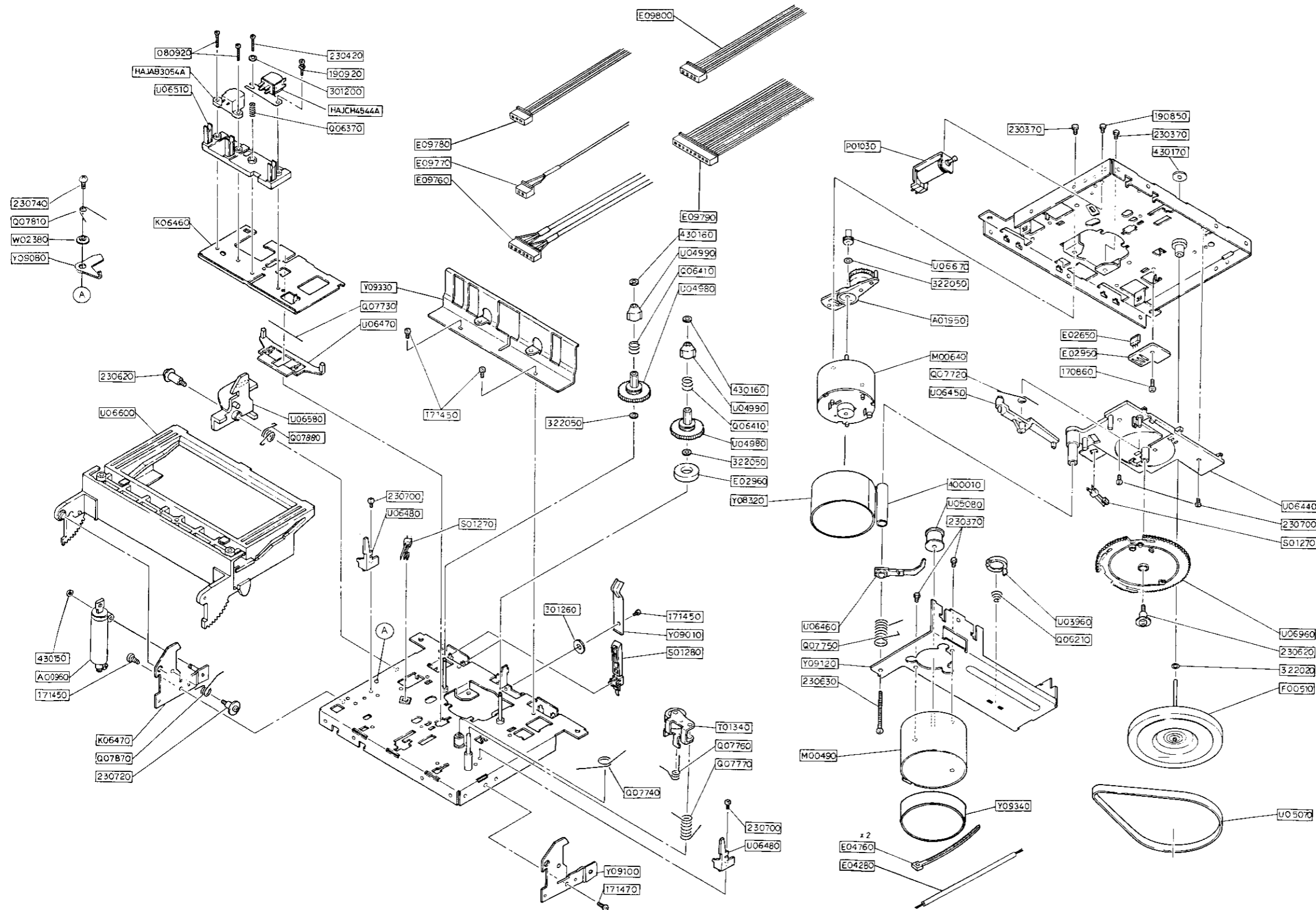

Q'TY	PART NO.	DESCRIPTION
1	A00960	SOFT DAMP ASSY 3B
1	A01950	RF ASSY 90A
1	E02650	HALL IC 0M6838-A
1	E02950	PCB, IC-20
1	E02960	MAGNET 15X7.2X3-12
1	E04280	WIRE,1571(RE) 35X3X3#28
2	E04760	HARNES BAND PL-100
1	E09760	CONNECTOR ASSY 25C-06F-05
1	E09770	CONNECTOR ASSY 25C-02F-04
1	E09780	CONNECTOR ASSY 25C-03F-04
1	E09790	CONNECTOR ASSY 25C-09F-05
1	E09800	CONNECTOR ASSY 25C-04F-05
1	F00510	FLYWHEEL 90B
1	HAJCH4544A	REC/PLAY HEAD
1	HAJAB3054A	ERASE HEAD
1	T01340	PINCH ROLLER ASSY 90A
1	K06460	HEAD PLATE 90A
1	K06470	CASE HOLDER 90A-L
1	M00490	MOTOR EG500AD-2B
1	M00640	MOTOR RF-510T-081200-N
1	P01030	SOLENOID MSD-4-00102-12V19
1	Q06210	SP, CAPSTAN SUPPORT 8RA
1	Q06370	SP, HEAD 9FA
2	Q06410	SP, REEL SUPPORT 9FA
1	Q07720	SP, LEVER TRIGGER 90A
1	Q07730	SP, ARM BRAKE 90A
1	Q07740	SP, HEAD PANEL 90A
1	Q07750	SP, ARM GEAR 90A
1	Q07760	SP, PINCH ROLLER 90A
1	Q07770	SP, PINCH RET 90A
1	Q07810	SP, ARM SAFETY 90A
1	U07870	SP, CASSETTE CASE 90B
1	Q07880	SP, CASE LOCK 90B
2	S01270	LEAF SW LSA-1119R-1
2	S01280	LEAF SW LSA-1132FAU
1	U03960	CAPSTAN SUPPORT 9B
2	U04980	GEAR,REEL PLATE 9FA
2	U04990	REEL DRIVE 9FA
1	U05070	FLAT BELT 58.5X3.5X0.4
1	U05080	MOTOR PULLEY 2X9.2R-U
1	U06440	GEAR,BASE 90A
1	U06450	LEVER,TRIGGER 90A
1	U06460	ARM,GEAR 90A
1	U06470	ARM,BRAKE 90A
2	U06480	CASSETTE GUIDE 90A
1	U06510	HEAD BASE 90B
1	U06580	LEVER, CASE LOCK 90A
1	U06600	CASSETTE CASE 90A
1	U06670	GEAR,RF PULLEY 90A
1	U06960	GEAR,DRIVE 90A
1	W02380	COLLAR,ARM SAFETY 90A
1	Y08320	SHIELD PLATE T-2.0 30X17
1	Y09010	SP PLATE,PACK 90A
1	Y09080	ARM,SAFETY 90A
1	Y09100	CASE HLDER 90A-R
1	Y09120	BRACKET,FLYWHEEL 90A
1	Y09330	COVER,SW 90B
1	Y09340	SHIELD PLATE T-2.0 34X17
2	090920	SCREW,BIND 2.0X11
1	170860	SCREW,TAP TITE 2.0X5
4	171450	SCREW,TAP TITE 2.6X4
1	171470	SCREW,TAP TITE 2.6X6
1	190850	SCREW,2.0X4W/SPRING WASHER
1	190920	SCREW,2.0X11W/SPRING WASHER
4	230370	SCREW,2.6X2.5
1	230420	SCREW,BIND 2.0X10
2	230620	SCREW,SHOULDECK 2.6X9
1	230630	SCREW,TAP TITE 2.6X2.5
4	230700	SCREW,BIND TAP TITE 2.0X4
1	230720	SCREW,SHOULDECK 2.6X5
1	230740	SCREW,TRUSS TAP TITE 2.6X6
1	301200	FW 2.2X6.0X0.4
1	301260	FW 2.8X7.5X0.5
1	322020	PSW 2.1X4.0X0.25
3	322050	PSW 2.1X4.0X0.5
1	400010	SPACER M2.6X20 ZMC
1	430150	PSW 2.1X4.0X0.4C
2	430160	PSW 1.6X3.2X0.40C
1	430170	NLW 1.9X7.0X0.5

EXPLODED VIEW
Main Unit and Packing

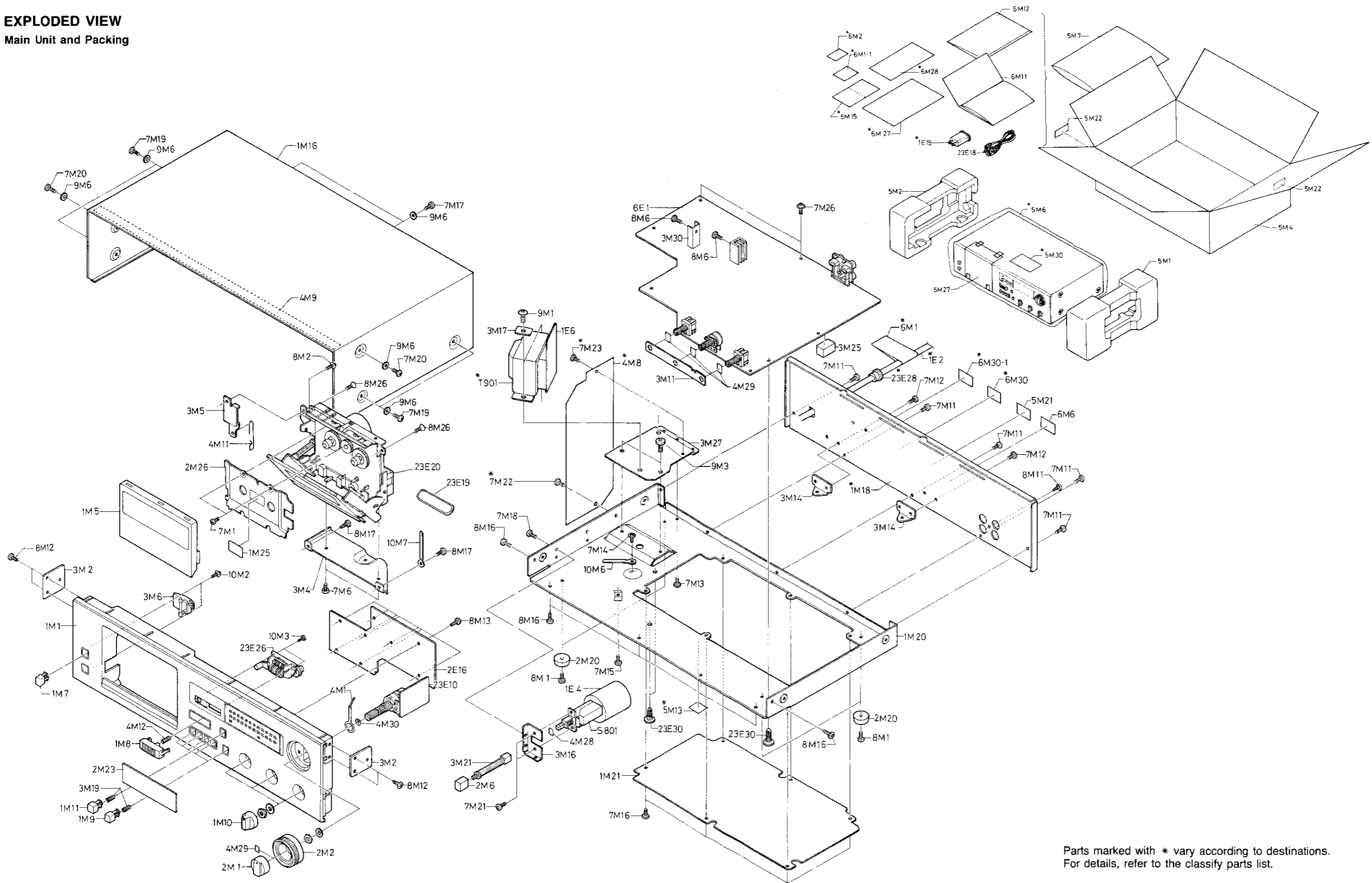

Parts marked with * vary according to destinations.
For details, refer to the classify parts list.

REF. NO.	Q'TY	PART NO.	DESCRIPTION
R086	1	KA16ST822J-UA	CARBON RESISTOR
R087	1	KA16ST223J-UA	CARBON RESISTOR
R088	1	KA16ST332J-UA	CARBON RESISTOR
R089	1	KA16ST103J-UA	CARBON RESISTOR
R090	1	KA16ST332J-UA	CARBON RESISTOR
R091	1	KA16ST153J-UA	CARBON RESISTOR
R092	1	KA16ST472J-UA	CARBON RESISTOR
R093	1	KA16ST223J-UA	CARBON RESISTOR
R094	1	KA16ST102J-UA	CARBON RESISTOR
R095	1	KA16ST472J-UA	CARBON RESISTOR
R101,102	2	KA16ST822J-UA	CARBON RESISTOR
R103-105	3	KA16ST102J-UA	CARBON RESISTOR
R107,108	2	KA16ST332J-UA	CARBON RESISTOR
R109,110	2	KA16ST103J-UA	CARBON RESISTOR
R111-114	4	KA16ST224J-UA	CARBON RESISTOR
R115,116	2	KA16ST103J-UA	CARBON RESISTOR
R117,118	2	KA16ST223J-UA	CARBON RESISTOR
R119,120	2	KA16ST104J-UA	CARBON RESISTOR
R121,122	2	KA16ST333J-UA	CARBON RESISTOR
R123-126	4	KA16ST224J-UA	CARBON RESISTOR
R127,128	2	KA16ST182J-UA	CARBON RESISTOR
R129,130	2	KA16ST153J-UA	CARBON RESISTOR
R131-134	4	KA16ST303J-UA	CARBON RESISTOR
R135,136	2	KA16ST472J-UA	CARBON RESISTOR
R137,138	2	KA16ST153J-UA	CARBON RESISTOR
R139,140	2	KA16ST203J-UA	CARBON RESISTOR
R141,142	2	KA16ST563J-UA	CARBON RESISTOR
R143,144	2	KA16ST103J-UA	CARBON RESISTOR
R145,146	2	KA16ST203J-UA	CARBON RESISTOR
R147,148	2	KA16ST272J-UA	CARBON RESISTOR
R149,150	2	KA16ST474J-UA	CARBON RESISTOR
R151,152	2	KA16ST102J-UA	CARBON RESISTOR
R153,154	2	KA16ST223J-UA	CARBON RESISTOR
R155,156	2	KA16ST474J-UA	CARBON RESISTOR
R157,158	2	KA16ST565J-UA	CARBON RESISTOR
R159,160	2	KA16ST473J-UA	CARBON RESISTOR
R161-164	4	KA16ST103J-UA	CARBON RESISTOR
R165,166	2	KA16ST333J-UA	CARBON RESISTOR
R167,168	2	KA16ST101J-UA	CARBON RESISTOR
R169,170	2	KA16ST103J-UA	CARBON RESISTOR
R171-174	4	KA16ST224J-UA	CARBON RESISTOR
R175,176	2	KA16ST223J-UA	CARBON RESISTOR
R171,192,194	3	KA16ST221J-UA	CARBON RESISTOR
R201-204	4	KA16ST153J-UA	CARBON RESISTOR
R205-208	4	KA16ST332J-UA	CARBON RESISTOR
R209,210	2	KA16ST333J-UA	CARBON RESISTOR
R211,212	2	KA16ST223J-UA	CARBON RESISTOR
R213-216	4	KA16ST153J-UA	CARBON RESISTOR
R217-220	4	KA16ST333J-UA	CARBON RESISTOR
R221,222	2	KA16ST823J-UA	CARBON RESISTOR
R223,224	2	KA16ST183J-UA	CARBON RESISTOR
R225,226	2	KA16ST823J-UA	CARBON RESISTOR
R227-232	6	KA16ST223J-UA	CARBON RESISTOR
R233,234	2	KA16ST153J-UA	CARBON RESISTOR
R235,236	2	KA16ST472J-UA	CARBON RESISTOR
R237,238	2	KA16ST223J-UA	CARBON RESISTOR
R239,240	2	KA16ST683J-UA	CARBON RESISTOR
R241,242	2	KA16ST105J-UA	CARBON RESISTOR
R243,244	2	KA16ST223J-UA	CARBON RESISTOR
R245,246	2	KA16ST333J-UA	CARBON RESISTOR
R247,254	8	KA16ST105J-UA	CARBON RESISTOR
R255,256	2	KA16ST101J-UA	CARBON RESISTOR
R257,258	2	KA16ST222J-UA	CARBON RESISTOR
R259,260	4	KA16ST471J-UA	CARBON RESISTOR
R261,268	2	KA16ST183J-UA	CARBON RESISTOR
R269,290	2	KA16ST472J-UA	CARBON RESISTOR
R301	1	KA16ST123J-UA	CARBON RESISTOR
R302	1	KA16ST224J-UA	CARBON RESISTOR
R303	1	KA16ST103J-UA	CARBON RESISTOR
R304	1	KA16ST223J-UA	CARBON RESISTOR
R358-360	3	KA16ST104J-UA	CARBON RESISTOR
R363	1	KA16ST473J-UA	CARBON RESISTOR
R367	1	KA16ST102J-UA	CARBON RESISTOR
R369	1	KA16ST681J-UA	CARBON RESISTOR
R369,370	2	KA16ST333J-UA	CARBON RESISTOR
R371	1	KA16ST331J-UA	CARBON RESISTOR
R372,373	2	KA16ST223J-UA	CARBON RESISTOR
R374,375	2	KA16ST104J-UA	CARBON RESISTOR
R377,378	2	KA16ST472J-UA	CARBON RESISTOR
R379	1	KA16ST152J-UA	CARBON RESISTOR
R380	1	KA16ST282J-UA	CARBON RESISTOR
R381	1	KA16ST562J-UA	CARBON RESISTOR
R382	1	KA16ST180J-UA	CARBON RESISTOR
R701	1	KA16ST473J-UA	CARBON RESISTOR
R702,703	2	KA16ST153J-UA	CARBON RESISTOR
R704	1	KA16ST105J-UA	CARBON RESISTOR
R705	1	KA16ST104J-UA	CARBON RESISTOR
R707,708	2	KA16ST223J-UA	CARBON RESISTOR
R709	1	KA16ST122J-UA	CARBON RESISTOR
R710	1	KA16ST153J-UA	CARBON RESISTOR
R711,712	2	KA16ST473J-UA	CARBON RESISTOR
R713	1	KA16ST222J-UA	CARBON RESISTOR
R714	1	KA16ST100J-UA	CARBON RESISTOR
R715	1	KA16ST331J-UA	CARBON RESISTOR
R716	1	KA16ST222J-UA	CARBON RESISTOR
R717,725	2	KA16ST682J-UA	CARBON RESISTOR
R726	1	KA16ST223J-UA	CARBON RESISTOR
R727	1	KA16ST152J-UA	CARBON RESISTOR

REF. NO.	Q'TY	PART NO.	DESCRIPTION
R728	1	KA16ST473J-UA	CARBON RESISTOR
R803	1	KA16ST102J-UA	CARBON RESISTOR
R804	1	KA16ST101J-UA	CARBON RESISTOR
VR001	1	EWG-G1A301B15	ROTARY POTENTIOMETER
SVR003,004	2	SVR-05T3B203	SEMI-VARIABLE RESISTOR
SVR101,102	2	SVR-06T3B103	SEMI-VARIABLE RESISTOR
SVR201,202	2	SVR-06T3B502	SEMI-VARIABLE RESISTOR
SVR301,302	2	SVR-06T3B204	SEMI-VARIABLE RESISTOR
SVR303	1	SVR-06T3B503	SEMI-VARIABLE RESISTOR
SVR304	1	SVR-05T3B203	SEMI-VARIABLE RESISTOR
<u>COILS</u>			
F101,102	2	184015	FILTER BLOCK
F201,202	2	184014	FILTER BLOCK
L201,202	2	RC875-223J	INDUCTOR
L203,204	2	RC875-393J	INDUCTOR
L303	1	191011	OSC COIL
<u>SWITCHES</u>			
S001,301	2	SW-2233236	ROTARY SWITCH
<u>MISCELLANEOUS</u>			
W001	1	0075240822-J-J	SOLDER-PLATED WIRE
W002	1	4685243819-J-J	3-LEAD, FLAT CABLE
W102	1	0075240810-J-J	SOLDER-PLATED WIRE
EL801	1	59851692	GND LUG
JP801	1	52011-0510	CONNECTOR
MP001	1	PI25C-06M	MICRO PLUG
MP301	1	PI25C-02M	MICRO PLUG
MP551	1	171825-4	MICRO PLUG
MP701	1	1L-507P52T2-EF	CONNECTOR
MP703	1	PI25C-03M	MICRO PLUG
MP704	1	PI25C-09M	MICRO PLUG
MP705	1	PI25C-04M	MICRO PLUG
MP803	1	B2P-SHF-1AA	MICRO PLUG
TP003,201	2	171825-3	MICRO PLUG
14E 1	1	YKC21-0018A	RCA JACK 4P
23E 7	101	E100-UA	JUMP WIRE
23E 8	19	E050-UA	JUMP WIRE
23E25	1	05H-1625-MP	HEAT SINK

REC. & BALANCE PCB ASS'Y

REF. NO.	Q'TY	PART NO.	DESCRIPTION
<u>P.C. BOARD</u>			
23E10	1	R4V-K045	PRINTED CIRCUIT BOARD
<u>RESISTORS</u>			
R177,178	2	KA16ST472J-UA	CARBON RESISTOR
VR101	1	EWJ-S1AW24A14	ROTARY POTENTIOMETER
<u>MISCELLANEOUS</u>			
W101	1	4685245830-J-J	5-LEAD, FLAT CABLE
W201,202	2	0075240807-C-C	SOLDER-PLATED WIRE

AC POWER SUPPLY PCB ASS'Y

REF. NO.	Q'TY	PART NO.	DESCRIPTION
<u>P.C. BOARD</u>			
1E 6	1	AC-K045	PRINTED CIRCUIT BOARD
<u>CAPACITORS</u>			
* C801	1	ECQU2A103MN	METALLIZED FILM CAPACITOR
<u>MISCELLANEOUS</u>			
W901	1	4685245826-J-J	5-LEAD, FLAT CABLE
1E 7	1	E100-UA	JUMP WIRE
AL801,802	2	59854795	GND LUG

LEVEL METER, KEY SW PCB ASS'Y

REF. NO.	Q'TY	PART NO.	DESCRIPTION
<u>P.C. BOARD</u>			
2E16	1	LMS-K046	PRINTED CIRCUIT BOARD
<u>SEMICONDUCTORS</u>			
D604	1	1N4148-UA	DIODE
Q601	1	RN1207	TRANSISTOR
IC551,552	2	L81408	IC
IC602	1	TC40138P	IC
LD551-566	16	LN342GP	LED
LD567,568	2	LN442YP	LED
LD569,570,601	3	LN242RP	LED
LD602	1	LN442YP	LED
LD603	1	LN342GP	LED
<u>CAPACITORS</u>			
C561,562	2	S5-16TW100M-KF	ELECTROLYTIC CAPACITOR
C563,564	2	S5-50TWR10M-KF	ELECTROLYTIC CAPACITOR
C565	1	S5-16TW100M-KF	ELECTROLYTIC CAPACITOR
C601	1	TP125X103N-UA	CERAMIC CAPACITOR
C602	1	S5-50TWR10M-KF	ELECTROLYTIC CAPACITOR
C603	1	TP125X103N-UA	CERAMIC CAPACITOR
<u>RESISTORS</u>			
R561,562	2	KA16ST332J-UA	CARBON RESISTOR
R563,564	2	KA16ST473J-UA	CARBON RESISTOR
R565	1	KA16ST821J-UA	CARBON RESISTOR
R601	1	KA16ST103J-UA	CARBON RESISTOR
R602	1	KA16ST105J-UA	CARBON RESISTOR
R603	1	KA16ST103J-UA	CARBON RESISTOR
R604	1	KA16ST473J-UA	CARBON RESISTOR
R605	1	KA16ST103J-UA	CARBON RESISTOR
R606	1	KA16ST681J-UA	CARBON RESISTOR
<u>SWITCHES</u>			
S602-608	7	SKHHAK	TACT SWITCH
<u>MISCELLANEOUS</u>			
3E24	11	E100-UA	JUMP WIRE
MC551	1	MC04-K070	MICRO SOCKET ASS'Y
MC602	1	MK07-K084	MICRO SOCKET ASS'Y
MC603	1	MC02-K083	MICRO SOCKET ASS'Y

OTHER PARTS

REF. NO.	Q'TY	PART NO.	DESCRIPTION
<u>MISCELLANEOUS</u>			
W801	1	672S220T20-C-D	SOLDER-PLATED WIRE
W802	1	672S220A20-C-D	SOLDER-PLATED WIRE
23E19	1	CV-6255	COUNTER BELT
23E23	4	BK-1	CORD CLAMP
23E24	5	NO.5167	CORD CLAMP

Capacitors Description

• Electrolytic

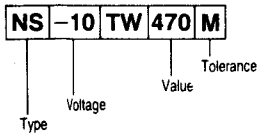

• Mylar - Styrol

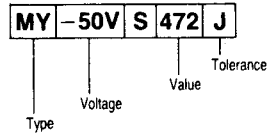

• Ceramic

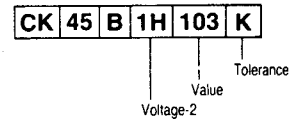
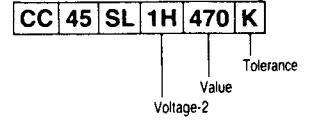
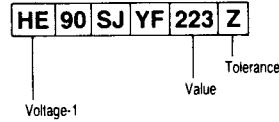

• Electrolytic

Type	Voltage	Value	Tolerance
LL: Low Leak	-10: 10V	R47: 0.47 μ F	K: \pm 10%
NP: Non-Pole	-50: 50V	4R7: 4.7 μ F	M: \pm 20%
NS: Standard	6R3: 6.3V	470: 47 μ F	
		471: 470 μ F	
		472: 4700 μ F	

• Mylar - Styrol

Type	Voltage	Value	Tolerance
MY: Mylar	-25V: 25V	4R7: 4.7pF	G: \pm 2%
ST: Styrol	125V: 125V	470: 47pF	J: \pm 5%
	-63T: 63V	471: 470pF	K: \pm 10%
		472: 4700pF	M: \pm 20%
		473: 0.047 μ F	
		474: 0.47 μ F	
		(1000pF=0.001 μ F)	

Voltage-1	Voltage-2	Value	Tolerance
HC: 25V	1E: 25V	4R7: 4.7pF	C: \pm 0.25pF
HE: 50V	1H: 50V	470: 47pF	D: \pm 0.5pF
H: 100V	2H: 500V	471: 470pF	F: \pm 1pF
HK: 250V		472: 4700pF	J: \pm 5%
HM: 500V		473: 0.047 μ F	K: \pm 10%
		474: 0.47 μ F	M: \pm 20%
		(1000pF=0.001 μ F)	Z: +80~-20%

Resistors Description

• Fixed

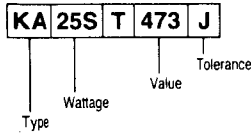

• Semi-Variable

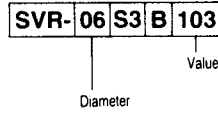

Type	Wattage	Value	Tolerance	Diameter
CE: Cement Case	-2W: 2W	R47: 0.47 Ω	M: \pm 20%	08: 8 ϕ
FR: Flame Proof	10W: 10W	4R7: 4.7 Ω	K: \pm 10%	10: 10 ϕ
KA: Carbon	16S: 1/6W	470: 47 Ω	J: \pm 5%	06: 6 ϕ
MF: Metal Film	20S: 1/5W	471: 470 Ω	G: \pm 2%	
RF: Fusible	25S: 1/4W	472: 4.7k Ω	F: \pm 1%	
SA: Metal Oxide	50S: 1/2W	473: 47k Ω	D: \pm 0.5%	
	50X: 1/2W	474: 470k Ω		
	S3W: 3W	475: 4.7M Ω		