

NAD **SERVICE**
MANUAL

5330

COMPACT DISC PLAYER

NAD 5330 SERVICE MANUAL

NOTICE: *This manual covers all versions*

A: North America & Canada
E: Europe & Others
U: UK
Y: Australia

TABLE OF CONTENTS	PAGE
SPECIFICATIONS	2
DISASSEMBLY INSTRUCTIONS	3
BLOCK DIAGRAM.....	6
ADJUSTMENTS.....	7
CAUTIONS ON LASER PICK-UP REPLACEMENT.....	9
IC TERMINAL FUNCTION	10
ELECTRICAL PARTS LOCATIONS AND WIRING DIAGRAM	12
SCHEMATIC DIAGRAM	14
MECHANISM EXPLODED VIEW.....	16
CABINET EXPLODED VIEW.....	17
PARTS LIST.....	18

REAR PANEL

1. Output jacks.
2. AC line cord.

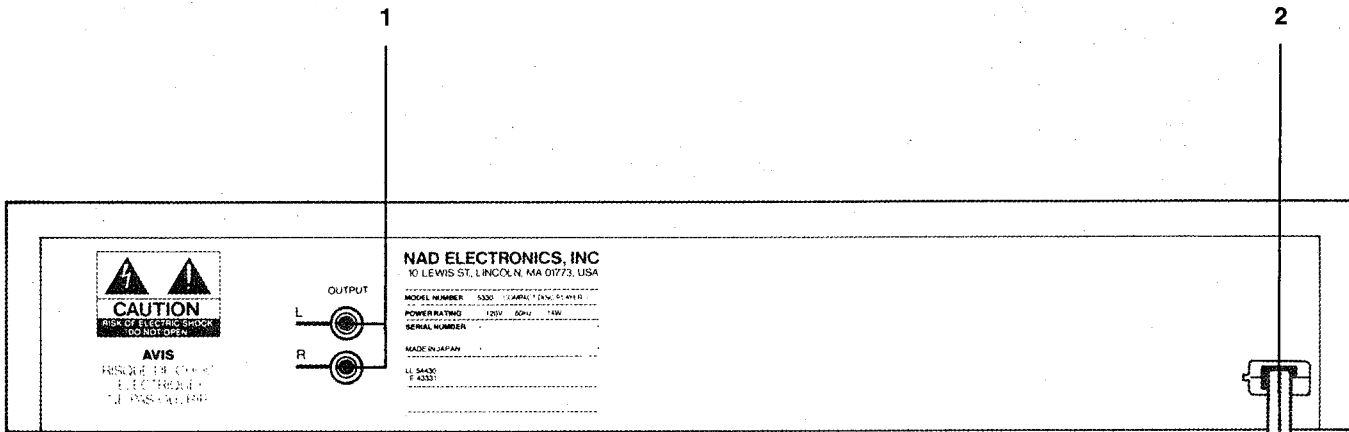



CAUTION
 RISK OF ELECTRIC SHOCK
 DO NOT OPEN

CAUTION TO REDUCE THE RISK OF ELECTRIC SHOCK, DO NOT REMOVE COVER (OR BACK). NO USER-SERVICEABLE PARTS INSIDE. REFER SERVICING TO QUALIFIED SERVICE PERSONNEL.

FRONT PANEL

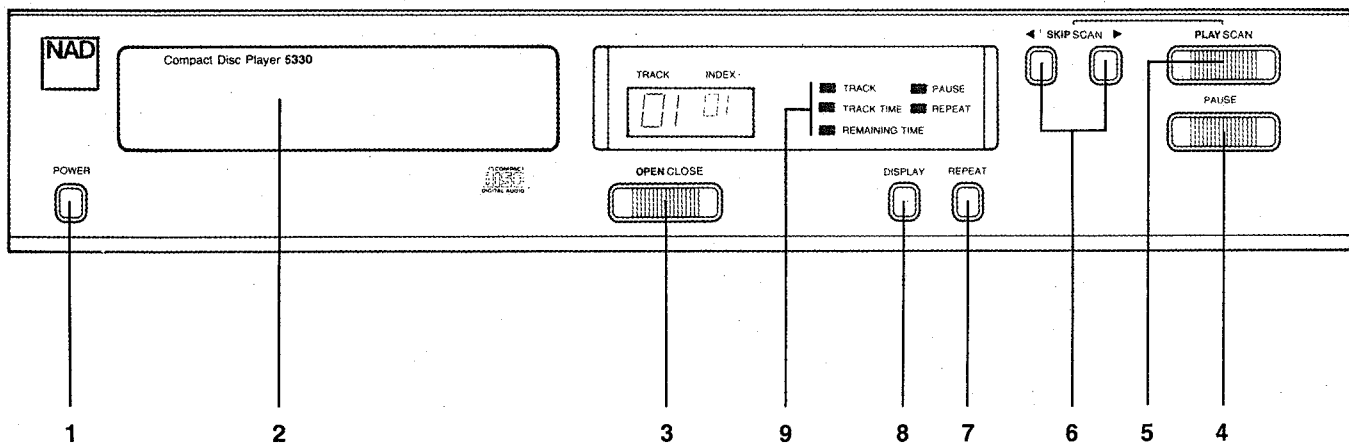
- | | |
|-----------------|----------------------|
| 1. Power. | 8. Display selector. |
| 2. Disc drawer. | 9. Display. |
| 3. Open/Close. | Track |
| 4. Pause. | Track Time |
| 5. Play. | Remaining Time |
| 6. Skip/Scan. | Pause |
| 7. Repeat. | Repeat |



 The lightning flash with arrowhead, within an equilateral triangle, is intended to alert the user of the presence of uninsulated "dangerous voltage" within the product's enclosure; that may be of sufficient magnitude to constitute a risk of electric shock to persons.

 The exclamation point within an equilateral triangle is intended to alert the user of the presence of important operating and maintenance (servicing) instructions in the literature accompanying the appliance.

SPECIFICATIONS

Type:	Compact Disc player with optical pickup
Quantization:	16 bit linear
Channels:	2 (Stereo)
Frequency response:	5 Hz – 20 kHz \pm 0.5 dB
Dynamic range:	Over 96 dB
Total harmonic distortion:	0.003% (1 kHz)
Channel separation:	Over 90 dB
Wow and flutter:	Unmeasurable
Output:	2.0 volts
Pickup:	Three beam semiconductor laser
Random access:	By track number
Power supply:	120V, 60 Hz for U.S.A. and Canada 110 – 120V/220 – 240V, 50 Hz for Europe, United Kingdom and Australia
Power consumption:	13 watts
Dimensions:	420(W) x 85(H) x 312(D) mm
Weight:	4.2 kg
Accessories:	Connection cord, Owner's manual

Specifications are subject to change without notice.

DISASSEMBLY INSTRUCTIONS

TOP COVER REMOVAL

1. Remove two screws (A) from side boards and four screws (B) from back board, and the top cover will be removed.



Figure 1



Figure 2

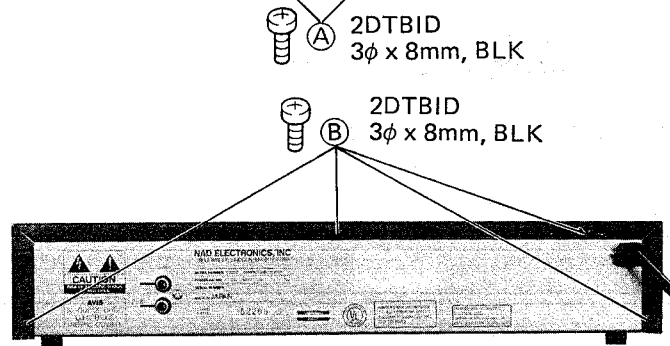

Figure 3

TRAY PANEL REMOVAL

1. Open disc tray.
2. Unhook two locations (C) on low side of tray panel, and the tray panel will be removed.

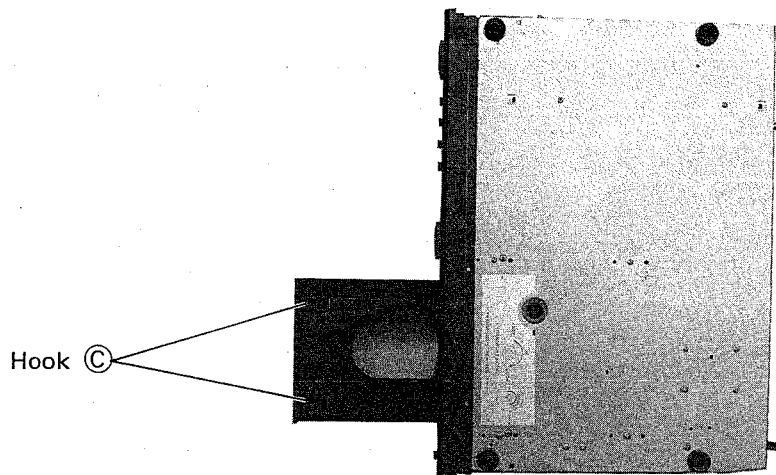

Figure 4

FRONT PANEL REMOVAL

1. Remove tray panel.
2. Remove three screws (D) from bottom plate and four screws (E) from side boards, and the front panel will be removed.

* Pay attention not to disconnect Display P.C. Board leads attached to front panel.

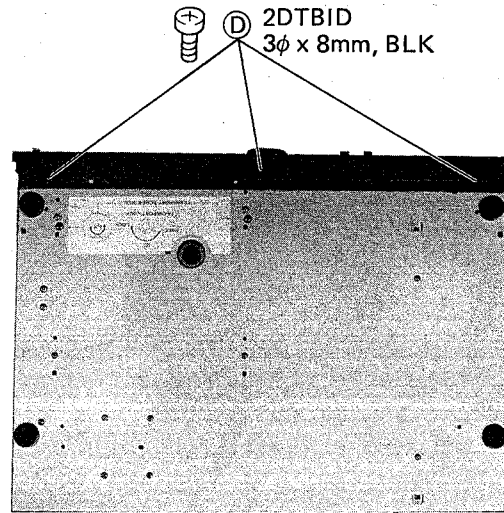

Figure 5

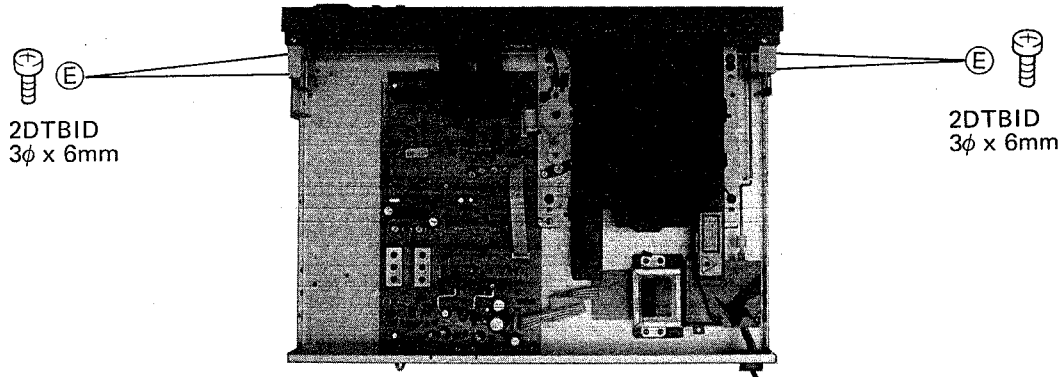

Figure 6

MECHANISM ASSEMBLY REMOVAL

1. Remove front panel.
2. Remove four screws (F), and the mechanism assembly will be removed.

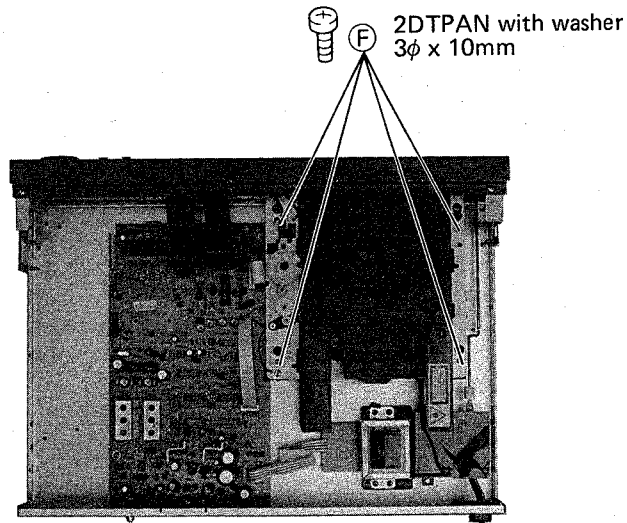

Figure 7

MECHANISM REMOVAL

1. Push clamber lever downward and push hook (G) horizontally, and then the clamber lever will be removed. (Figure 8)
2. Pull disc tray to the direction indicated by arrow, and the disc tray will be removed. (Figure 9)

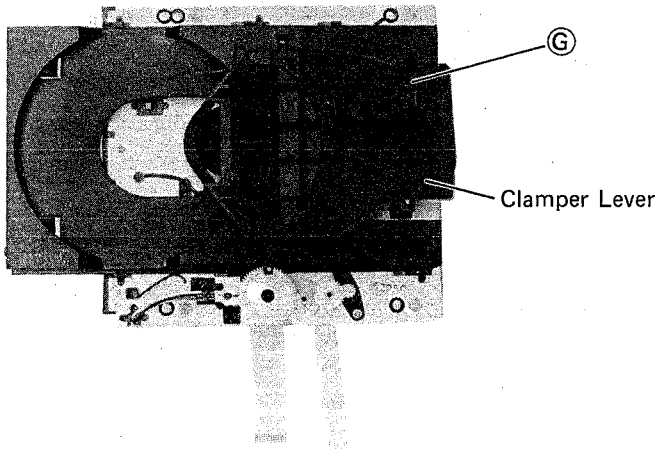

Figure 8

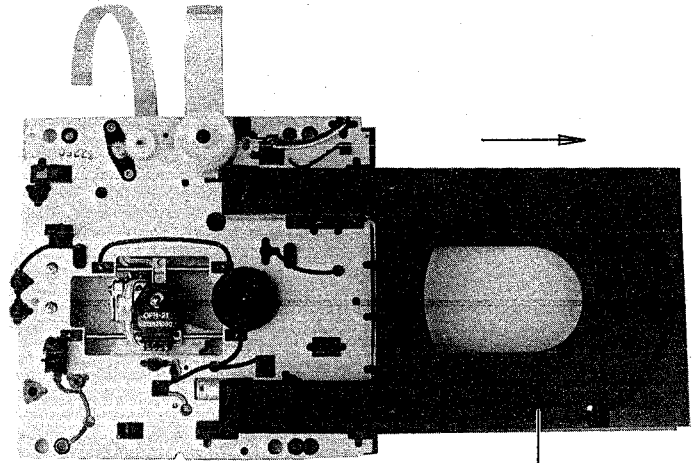

Figure 9

3. Remove two screws (H) (Figure 10) and one screw (I) (Figure 11), and the loading motor P.C. Board will be removed.
4. Remove one screw (J) and pulley drive gear, and the pickup motor assembly will be removed. (Figure 11)
5. Remove four screws (K), and the pickup will be removed. (Figure 11)
6. Remove disc table and two screws (L), and the disc motor assembly will be removed. (Figure 10)

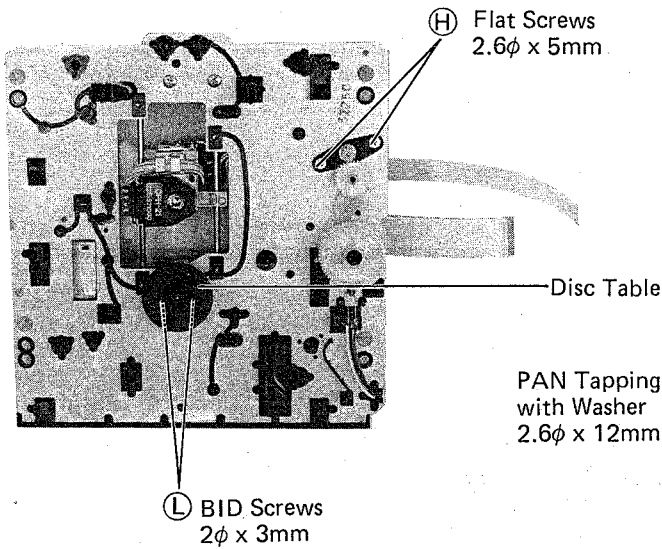

Figure 10

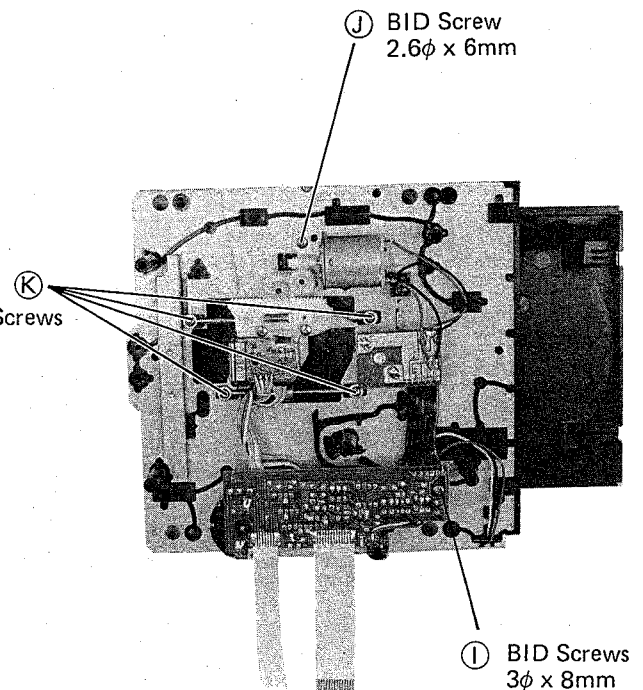

Figure 11

Insert spacer (5mm), which was packed with motor, between main chassis and disc table. Push center of disc table until it touches spacer. ($13 \pm 0.1\text{mm}$ from rubber on disc table)

Notes:

1. When mounting disc table, take care of disc table not to touch pickup or disc tray.
2. Mount disc table in parallel with main chassis.

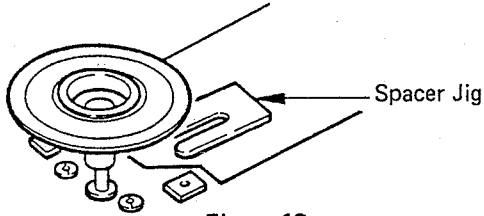

Figure 12

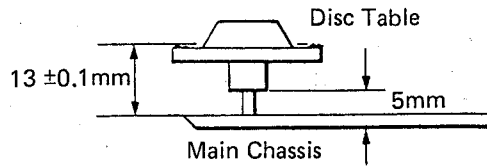

Figure 13

INSERTING DISC TRAY

Turn cam gear counterclockwise fully until leaf switch (M) moves to the mount outer position.

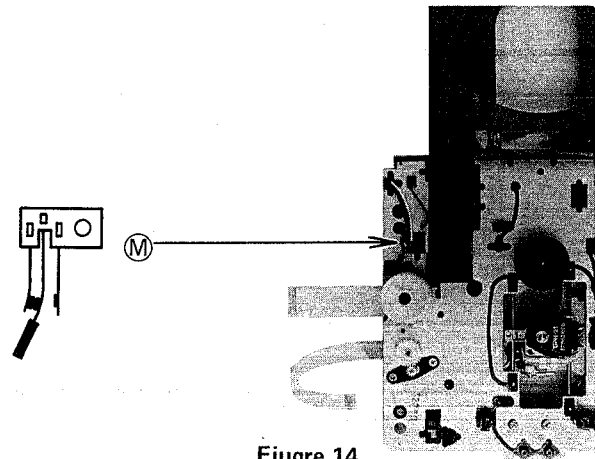

Figure 14

BLOCK DIAGRAM

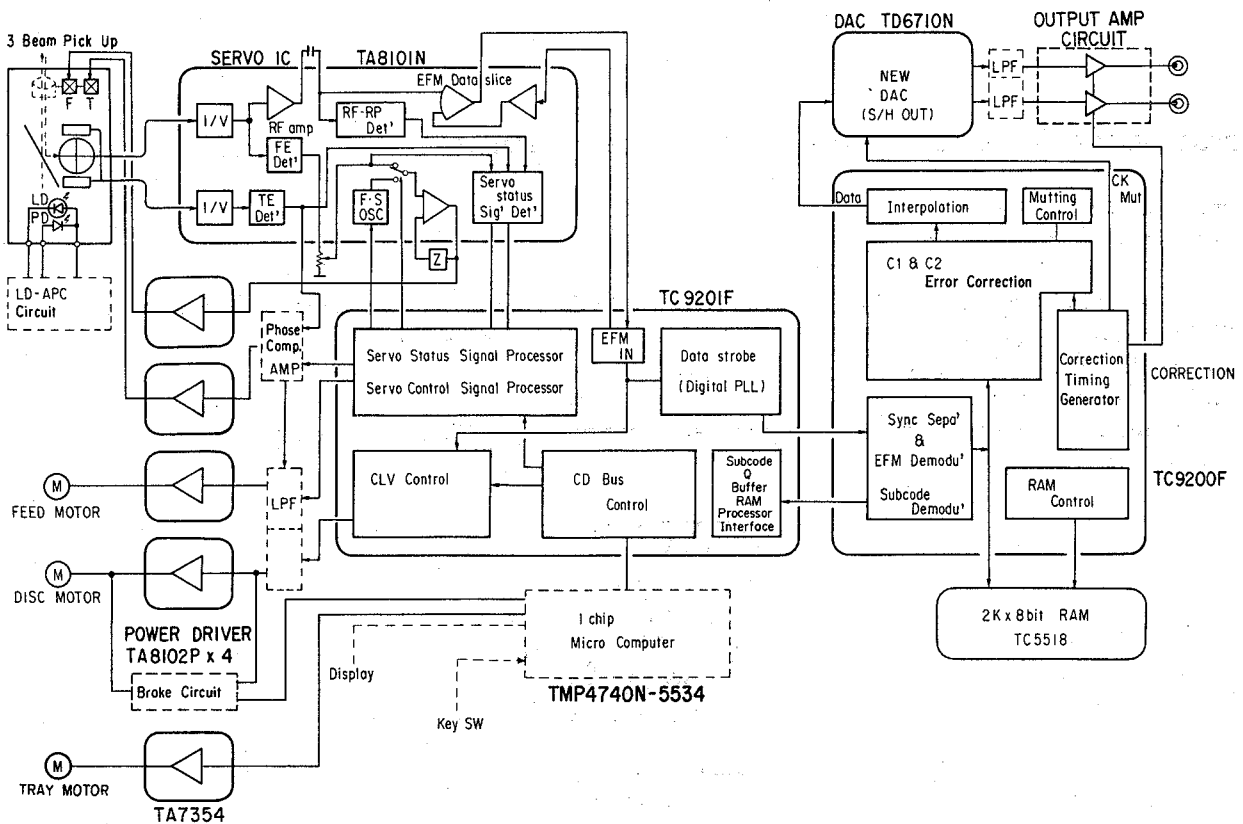
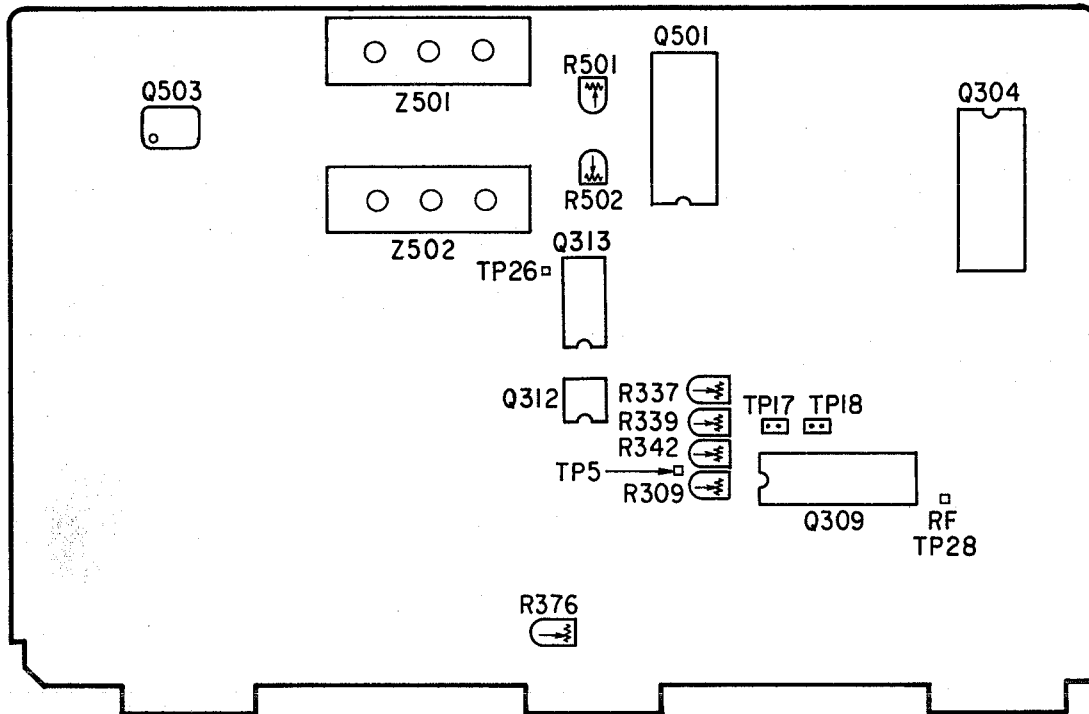

Figure 15

ADJUSTMENTS



Main P.C. Board

Figure 16

■ ADJUSTMENT PROCEDURES AFTER LASER PICKUP REPLACEMENT

1. Remove tray.
2. Remove clamber.
3. Focus balance and offset adjustment
 - 1) Set unit to STOP mode.
 - 2) Connect oscilloscope across TP17 (FE) and TP5 (VREF). (Focus error signal) (DC range: 5mV/DIV.)
 - 3) Adjust semi-fixed resistor R339 (100K ohm) so that DC offset obtains 0V \pm 10mV.
 - 4) Play back YEDS-7 DISC. (Any Track No. is available.)
 - 5) Connect oscilloscope across TP5 (VREF) and TP28 (RF). (AC range: 0.2V/DIV., 0.5 μ sec./DIV.)
 - 6) Adjust semi-fixed resistor R342 (20K ohm) so that 3T component of RF signal obtains max.

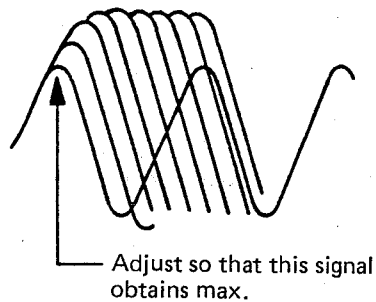

Figure 17

4. Tracking error balance and offset adjustment

- 1) Set unit to STOP mode.
- 2) Connect oscilloscope across TP18 (TE signal) and TP5 (VREF). (DC range: 5mV/DIV.)
- 3) Adjust semi-fixed resistor R337 (100K ohm) so that DC offset obtains $0V \pm 10mV$.

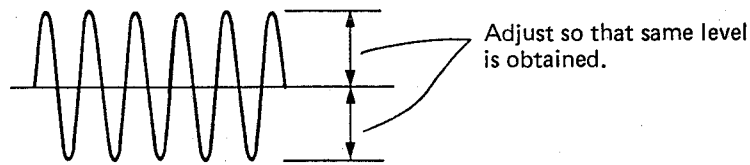

Figure 18

- 4) Play back YEDS-7 DISC.
 - 5) Set oscilloscope range to DC 0.5V/DIV, 5msec./DIV.
 - 6) Set unit to search mode by UP/DOWN key.
 - 7) Adjust semi-fixed resistor R309 (100K ohm) so that DC offset of tracking error signal obtains $0V$ during searching.
- #### 5. Analog output offset adjustment
- This adjustment is not needed when pickup is replaced.
- 1) Turn power of unit ON.
 - 2) Connect DC voltmeter or oscilloscope to Q503 pin 1 (L ch) and pin 7 (R ch) on Main P.C. Board.
Adjust semi-fixed resistor R502 50K ohm (L ch) and R501 50K ohm (R ch) so that offset (DC range) obtains $0 \pm 10mV$.

DISC MOTOR BRAKE ADJUSTMENT

1. Short-circuit pins 3 and 4 of Q313 (TC4053BP).
2. Connect pin 14 (TP26) to VREF (TP5).
3. Turn power on.
4. Connect oscilloscope probe across pin 7 of Q312 and VREF (TP5). (5mV range)
5. Adjust semi-fixed VR R376 (50K ohm) by turning it so that voltage output obtains within $\pm 5mV$.

CAUTIONS ON LASER PICK-UP REPLACEMENT

■ CAUTIONS ON LASER PICKUP REMOVAL

1. When removing laser pickup, solder and short-circuit its terminals to protect laser pickup from damage which may be caused during the removal. (Refer to Figures 19 and 20)
2. Disconnect connector and leads after soldering is completed. Do not touch the pickup terminals with your hand.
3. When mounting laser pickup, connect the counter and leads before unsoldering the solder used to short-circuit.

■ CAUTIONS ON LASER PICKUP REPLACEMENT

1. When mounting a new laser pickup, first connect the connector and leads and then unsolder the solder used to protect laser diode on P.C. Board. (Refer to Figures 19 and 20)
- * Use a soldering iron grounded (or leakageless iron).
 - * Cover working bench with conductive mat grounded.
 - * Before proceeding job, always touch the conductive mat or ground lead with your both hands to discharge electric charges developed on your body.

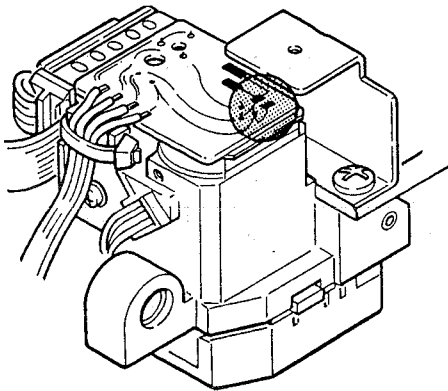

Figure 19

- Solder the patterns shown in illustration before disconnecting connector and leads.

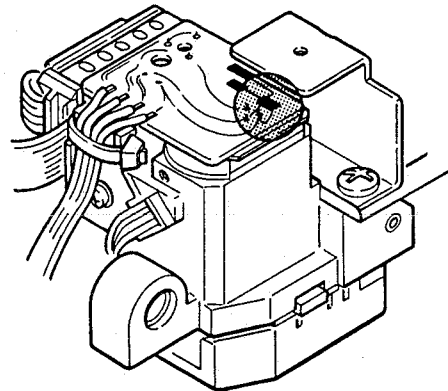

Figure 20

- Terminal soldered.

IC TERMINAL FUNCTION

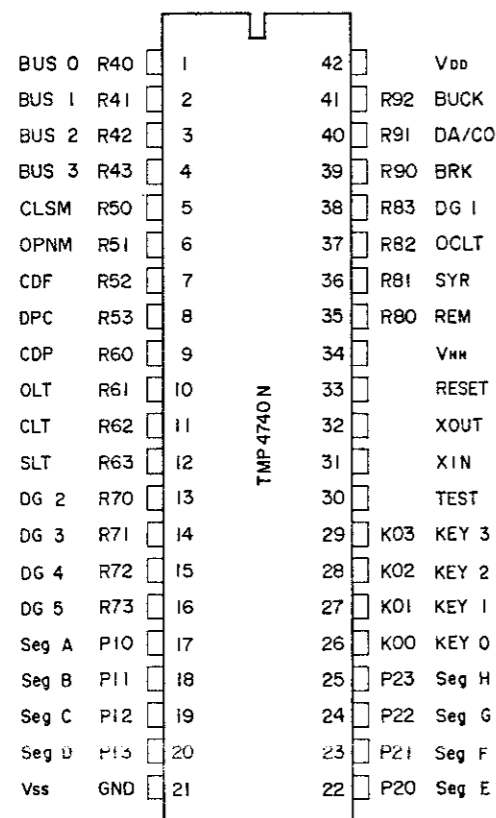

Figure 21

TMP4740N Terminals Function

Pin No.	Port Name	Signal Name	Input & Output	Initial Value	Function	
1	R4	R40	BUS0	Input & Output	H	I/O DATA BUS for servo control IC TC9201.
2		R41	BUS1	Input & Output	H	Same as above.
3		R42	BUS2	Input & Output	H	Same as above.
4		R43	BUS3	Input & Output	H	Same as above.
5	R5	R50	CLSM	Output	L	Tray motor control output. Tray close operation at "H".
6		R51	OPNM	Output	L	Tray motor control output. Tray open operation at "H".
7		R52	CDF	Output	L	CD-FUNCTION signal. Plus polarity pulse is outputted for 100msec. at PLAY-KEY ON.
8		R53	DPC	Output	L	DECK-PAUSE-CONTROL signal output. C-DECK START at "H". STOP at "L".
9		R60	CDP	Input	*	CD-PAUSE control signal input. CD transmits to PAUSE mode at "L". (not PLAY mode)
10	R6	R61	OLT	Input	*	OPEN-LIMIT switch input. "L" when tray is opened completely.
11		R62	CLT	Input	*	CLOSE-LIMIT switch input. "L" when tray is closed and disc clamp is completed.
12		R63	SLT	Input	*	START-LIMIT switch input. "L" when PU enters TOC area.

Pin No.	Port Name	Signal Name	Input & Output	Initial Value	Function	
13	R7	R70	DG2	Output	L	Display digit selection signal output. (Selects at "H".) Output for KEY scan.
14		R71	DG3	Output	L	Display digit selection signal output. Output for KEY scan.
15		R72	DG4	Output	L	Display digit selection signal output.
16		R73	DG5	Output	L	Display digit selection signal output.
17	P1	P10	Seg A	Output	H	Output for segment display. (ON at "L".) (1) a segment (2) Colon 1
18		P11	Seg B	Output	H	Output for segment display. (ON at "L".) (1) b segment (2) PAUSE indicator
19		P12	Seg C	Output	H	Output for segment display. (ON at "L".) (1) c segment (2) Colon 2
20		P13	Seg D	Output	H	Output for segment display. (ON at "L".) (1) d segment (2) REPEAT indicator
22	P2	P20	Seg E	Output	H	Output for segment display. (ON at "L".) (1) e segment (2) TNO indicator
23		P21	Seg F	Output	H	Output for segment display. (ON at "L".) (1) f segment (2) LAP indicator
24		P22	Seg G	Output	H	Output for segment display. (ON at "L".) (1) g segment (2) REMAIN indicator
25		P23	Seg H	Output	H	Output for segment display. (ON at "L".) (2) MEMORY indicator
26	K0	K00	KEY0	Input	*	KEY sense signal input. (1) PLAY (2) DISPLAY (3) STOP inhibit
27		K01	KEY1	Input	*	KEY sense signal input. (1) PAUSE (2) MEMORY
28		K02	KEY2	Input	*	KEY sense signal input. (1) UP (2) REPEAT
29		K03	KEY3	Input	*	KEY sense signal input. (1) DOWN (2) EJECT
35	R8	R80	REM	Input & Output	"H" (Input mode)	Remote control DATA signal input.
36		R81	SYR	Input	*	SYNCHRO-REC MODE setting input. SYNCHRO ON at "L", OFF at "H".
37		R82	OCLT	Input	*	Tray motor over current detection signal input.
38		R83	DG1	Output	L	Display digit selecting signal output. (Select at "H".)
39	R9	R90	BRK	Output	L	DISC MOTOR brake control signal output. When stopping DISC MOTOR, pulse is outputted for 1.2 sec.
40		R91	DA/CO	Input & Output	"H" (Input mode)	CD-BUS control signal.
41		R92	BUCK	Output	H	Shift clock for transmission with TC9201.
21		VSS	GND			Power supply (0V).
30		TEST	TEST	Input		TEST MODE terminal * Connect it to GND.
31		XIN	4M	Input		Basic clock input terminal
32		XOUT	NC	Output		Open
33		RESET	RESET	Input		Initialize signal input. Initialize operation at "L".
34		VHH	VHH			Power supply for memory backup. Connect it to VDD.
42		VDD	VDD			Power supply (+5V).

ELECTRICAL PARTS LOCATIONS

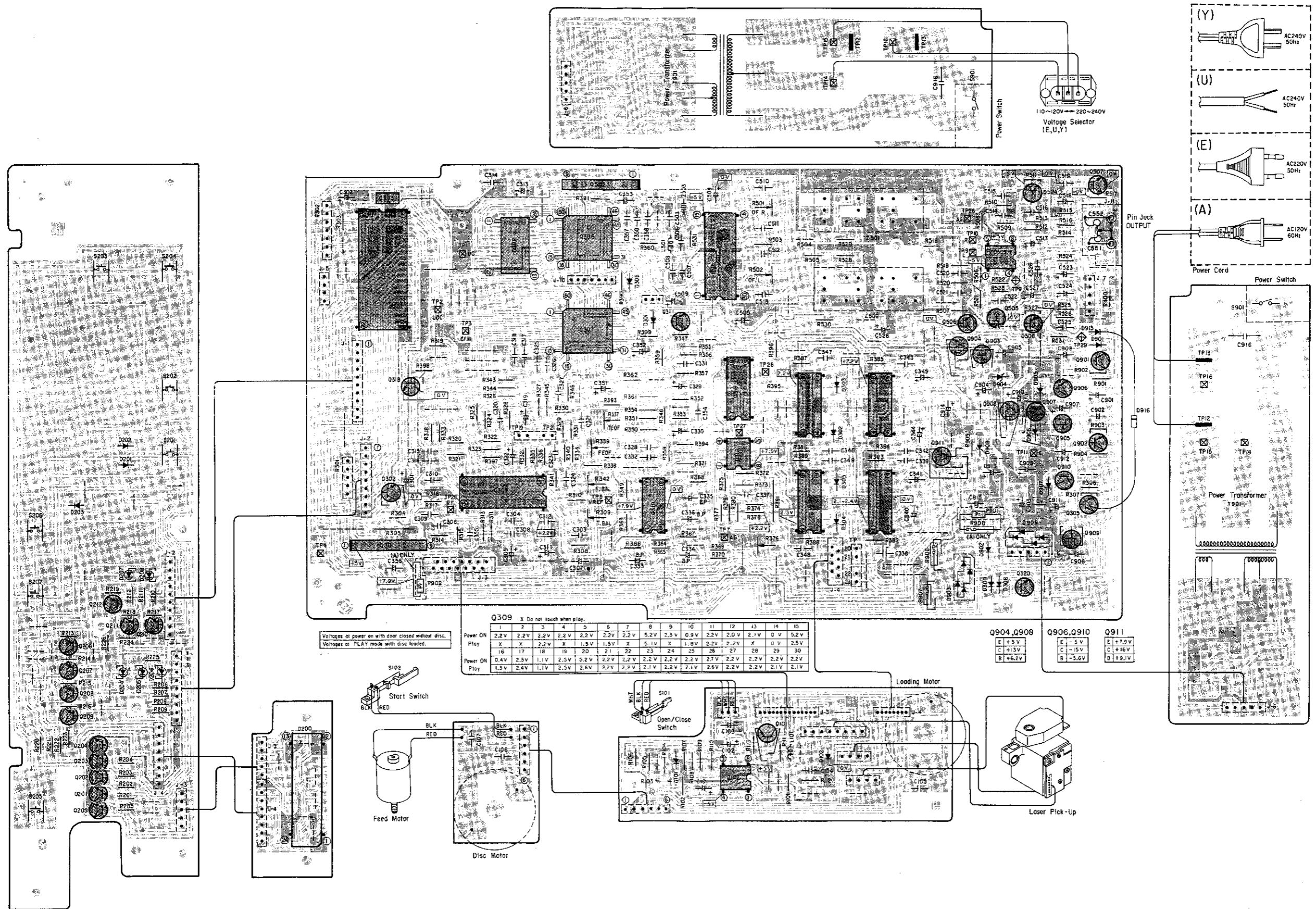

Figure 22

MECHANISM EXPLODED VIEW

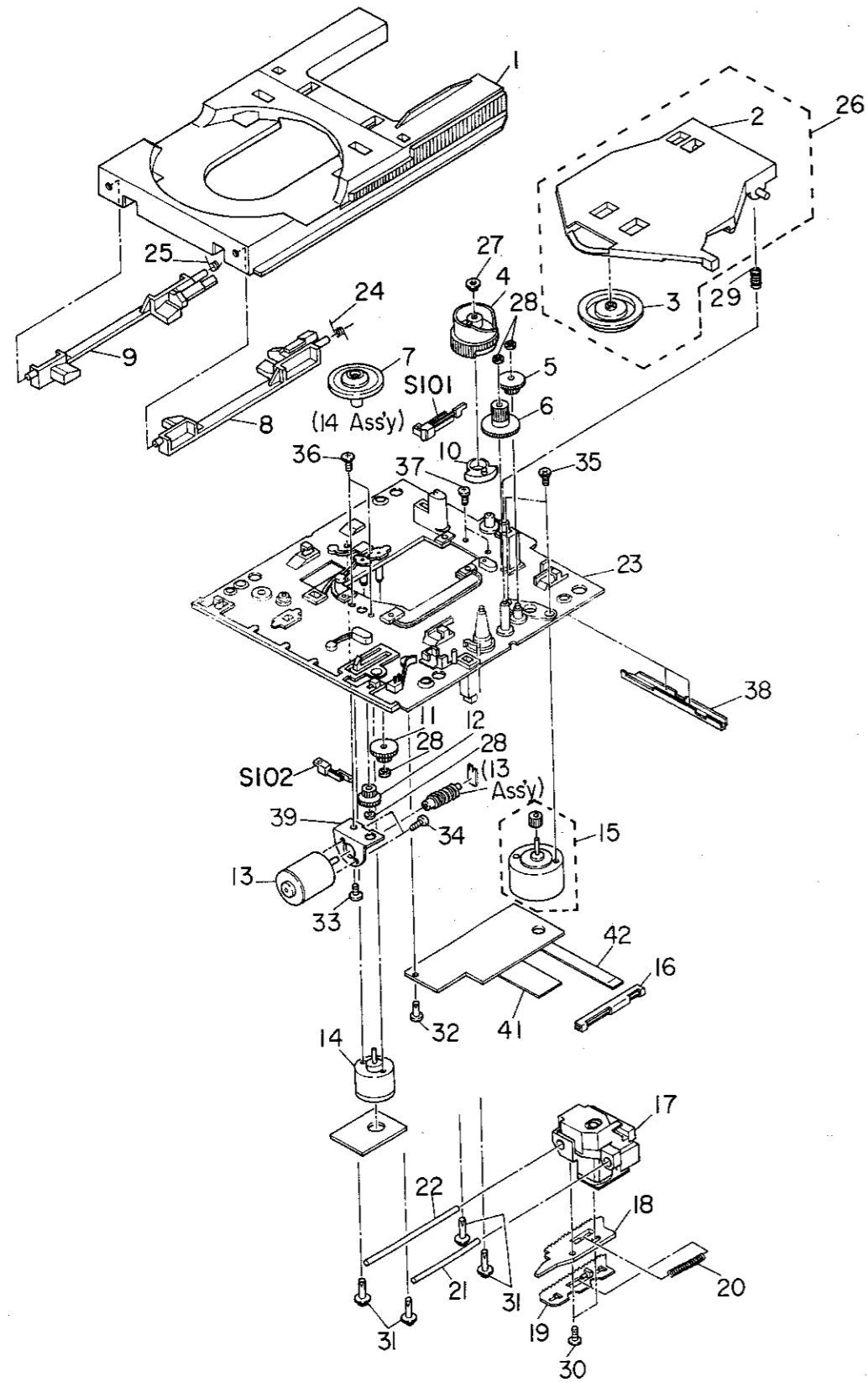

Figure 24
 16 **NOTE:** Parts excluded in the parts list are not stocked since they are seldom required for routine service. Some delay should be anticipated when ordering these items.

CABINET EXPLODED VIEW

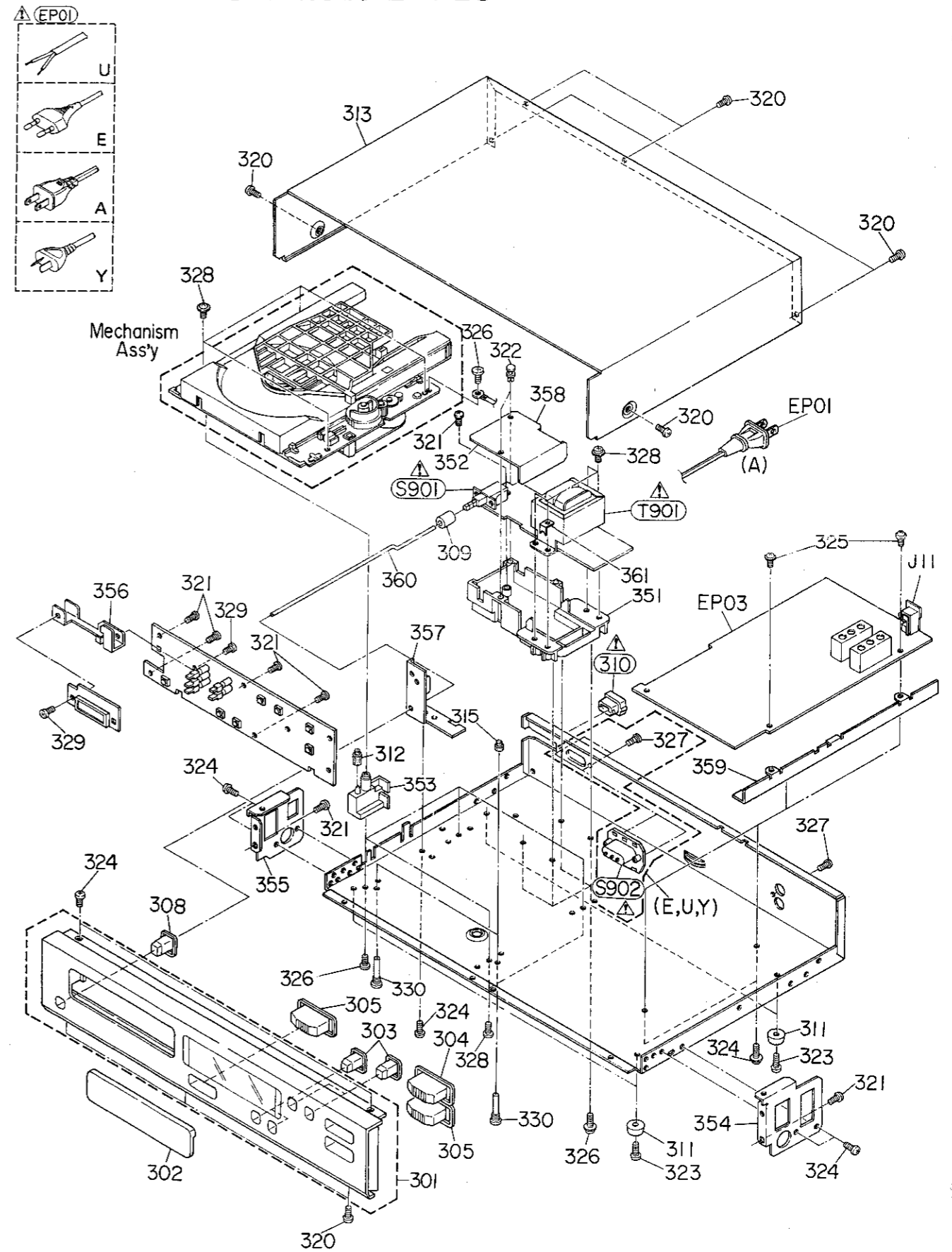



Figure 25
 17 **NOTE:** Parts excluded in the parts list are not stocked since they are seldom required for routine service. Some delay should be anticipated when ordering these items.

PARTS LIST

CAUTION:

The  mark, the symbol No. circled with oval in the schematic diagram and the shaded area in the parts list designate components which have special characteristics important for safety and should be replaced only with types identical to those in the original circuit or specified in the parts list.

Symbol No.	Part No.	Description
MACHANICAL ASSEMBLY		
1	20778195	Disc Tray
4	20727166	Cam Gear
5	20727164	Gear, Drive A
6	20727165	Gear, Drive B
7	20723159	Disc Table
8	20754257	Disc Lifter, R
9	20754256	Disc Lifter, L
10	20754255	Cam Switch
11	20727161	Gear, Pulley Drive A
12	20727162	Gear, Pulley Drive B
13	25792091	Pick Up Motor Ass'y
14	25792092	Disc Motor Ass'y
15	25792093	Loading Motor Ass'y
17	22155210	Pick Up, OPH-21
18	20727159	Rack Gear, A
19	20727160	Rack Gear, B
20	25777533	Spring, Rack
21	20764280	Guide Shaft, A
22	20764266	Guide Shaft, B
23	20743180	Main Chassis
24	25778401	Spring, Lifter, R
25	25778400	Spring, Lifter, L
26	20778207	Clamper Lever Ass'y
27	25783260	Bush
28	25783239	Bush
29	25777531	Spring, Clamper Lever
30	22708531	Screw, $\phi 2.6 \times 5\text{mm}$, BID
31	22708096	Screw, $\phi 2.6 \times 12\text{mm}$, BID Tapping
32	22701338	Screw, $\phi 2.6 \times 8\text{mm}$, BID Tapping
33	22707366	Screw, $\phi 2.6 \times 6\text{mm}$, BID
34	22708528	Screw, $\phi 2.6 \times 3\text{mm}$, BID
35	22701361	Screw, $\phi 2.6 \times 5\text{mm}$, FLT
36	22701467	Screw, $\phi 2 \times 3\text{mm}$, BID
37	22708542	Screw, $\phi 3 \times 8\text{mm}$, BID
38	20743183	Support, Chassis

Symbol No.	Part No.	Description
CABINET ASSEMBLY		
301	20017321	Front Panel Ass'y
302	20831557	Tray Panel
303	22884364	Knob, DISPLAY/REPEAT/ SKIP
304	20872105	Knob, Play
305	22884663	Knob, OPEN/PAUSE
308	22884362	Knob, Power
309	22764307	Joint, Power Knob
	25844322	Card Bush
311	22874085	Foot
312	25761545	Cushion, Mechanism
313	20823127	Top Cover
315	22764374	Cushion, Carrying
320	22707911	Screw, $\phi 3 \times 8\text{mm}$, BID Tapping, BLACK
321	22702202	Screw, $\phi 3 \times 8\text{mm}$, BID Tapping, RED
322	22705020	Plastic Rivet, $\phi 3 \times 4.5\text{mm}$
323	22708033	Screw, $\phi 3 \times 10\text{mm}$, BID Tapping
324	22707910	Screw, $\phi 3 \times 6\text{mm}$, BID Tapping
325	22708022	Screw, $\phi 3 \times 6\text{mm}$, PAN Tapping with Washer, RED
326	22708045	Screw, $\phi 3 \times 8\text{mm}$, PAN Tapping
327	22708118	Screw, $\phi 3 \times 8\text{mm}$, BID
328	22707798	Screw, $\phi 3 \times 10\text{mm}$, PAN Tapping with Washer
329	22708539	Screw, $\phi 3 \times 6\text{mm}$, BID
330	22708593	Screw, Pick-up, RED
331	22907162	Caution Label, Screw

CAUTION:

The Δ mark, the symbol No. circled with oval in the schematic diagram and the shaded area in the parts list designate components which have special characteristics important for safety and should be replaced only with types identical to those in the original circuit or specified in the parts list.

Symbol No.	Part No.	Description
ICS, TRANSISTORS & DIODES		
Q101 Q102	A6325540 22117698	Transistor, 2SC2236-Y IC, NJM2904D
Q201, 202, 203, 204, 205	A6753140	Transistor, 2SC982TM
Q206, 207, 208, 209, 210, 211, 212	A6534440	Transistor, 2SA1048-GR
Q301	B0325460	IC, TA7354P
Q302	A6332440	Transistor, 2SC2458-GR
Q303	22117743	Transistor, PST520D-T
Q304	22117817	IC, TMP4740N-5534
Q305	A6534060	Transistor, 2SA1015-GR
Q306	B0412001	IC, TC9200F-BS
Q307	B0412011	IC, TC9201F-BS
Q308	B0483585	IC, TC5518BFL-20 (T)
Q309	B0377580	IC, TA8101N
Q310	22117709	IC, NJM3403AD
Q311	A6342210	Transistor, 2SC2878-B
Q312	22117698	IC, NJM2904D
Q313	B0470532	IC, TC4053BP
Q314, 315, 316, 317	B0377590	IC, TA8102P
Q318	A6332440	Transistor, 2SC2458-GR
Q501	B0272760	IC, TD6709N
Q502	B0271770	IC, TD6102P
Q503	22117716	IC, NJM2068D-D
Q504, 505	A6058730	Transistor, 2SK365-BL
Q506	A6534440	Transistor, 2SA1048-GR
Q507, 508	A6342210	Transistor, 2SC2878-B
Q901	A6534440	Transistor, 2SA1048-GR
Q902	A6342200	Transistor, 2SC2878-A
Q903	A6058730	Transistor, 2SK365-BL
Q904	A6868350	Transistor, 2SD1413
Q905	A6058730	Transistor, 2SK365-BL
Q906	A6533240	Transistor, 2SA966Y
Q907	A6058730	Transistor, 2SK365-BL
Q908	A6868350	Transistor, 2SD1413
Q909	A6058730	Transistor, 2SK365-BL
Q910	A6533240	Transistor, 2SA966Y
Q911	A6868350	Transistor, 2SD1413

Symbol No.	Part No.	Description
D101, 102	A7160570	Diode, 1SS176
D200	A8635485	Diode, TLG4385
D201, 202, 203	A7160570	Diode, 1SS176
D204, 205, 206	A8606660	Diode, TLG208
D207, 208	A8608850	Diode, TLY208
D301, 302, 303, 304, 305, 306	A7160570	Diode, 1SS176
D901, 902	A7160570	Diode, 1SS176
Δ D903	22119188	Diode, SIVB10
D904	A7116525	Diode, 04AZ6.2Z
D905	A7116415	Diode, 04AZ5.6Y
D906	A7116525	Diode, 04AZ6.2Z
D907	A7116415	Diode, 04AZ5.6Y
D908	A7116915	Diode, 04AZ9.1Y
Δ D909	22119188	Diode, SIVB10
D915, 916	A7160570	Diode, 1SS176
ELECTRICAL PARTS		
Δ T901	22224612	Power Transformer (A)
Δ T901	22224805	Power Transformer (E)
Δ T901	22224807	Power Transformer (U)
Δ T901	22224841	Power Transformer (Y)
S101	22196598	Leaf Switch, Tray Open/ Close
S102	22196719	Leaf Switch, Pick, Start Limit
S201, 202	22196228	Key Switch, DOWN/UP
S203, 204	22196228	Key Switch, PAUSE/PLAY
S205, 206	22196228	Key Switch, EJECT/REPEAT
S207	22196228	Key Switch, DISPLAY
Δ S901	22196362	Power Switch (A, E, Y)
Δ S901	22196465	Power Switch (U)
Δ S902	22169173	AC Socket 3P (E, U, Y)
Δ EP01	22176286	Power Cord (E)
Δ EP01	22176573	Power Cord (A)
Δ EP01	22176588	Power Cord (Y)
Δ EP01	22176628	Power Cord (U)
EP03	22130825	Main P.C. Board Ass'y

Symbol No.	Part No.	Description
J001	22198227	Jack, US-2P
L101	22291189	Choke Coil, 10 μ H
L501	22291401	Choke Coil, 0.22 μ H
Z501, 502	22137774	Low-pass-filter
Z503	22153390	Oscillator, 67 MHz

CAPACITORS

D = $\pm 0.5\text{pF}$, J = $\pm 5\%$, K = $\pm 10\%$, M = $\pm 20\%$, Z = $-20+80\%$, P = $0+100\%$

ABBREVIATIONS: EL = Electrolytic, BL = Barrier Layer, CD = Ceramic Disk, MY = Mylar, PP = Polypropylene

C101, 102, 103	22440240	EL, 100mfd, 10V
C104	22360329	BL, 0.022mfd, 25V, M
C105, 106, 107	22341103	CD, 0.01mfd, 50V, P
C301	22483470	EL, 47mfd, 10V
C302	22488338	EL, 0.33mfd, 50V
C303, 304	22361330	CD, 33pF, 50V, J
C305	22483221	EL, 220mfd, 10V
C306	22360880	BL, 0.1mfd, 16V, Z
C307	22485220	EL, 22mfd, 16V
C308	22361709	CD, 7pF, 50V, D
C309, 310	22360544	BL, 0.01mfd, 25V, K
C311	22483101	EL, 100mfd, 10V
C312	22360880	BL, 0.1mfd, 16V, Z
C313	22483101	EL, 100mfd, 10V
C314	22360880	BL, 0.1mfd, 16V, Z
C315, 316, 317, 318	22361470	CD, 47pF, 50V, J
C319	22488229	EL, 2.2mfd, 50V
C320	22361220	CD, 22pF, 50V, J
C321	22371393	MY, 0.039mfd, 50V, J
C322	22483470	EL, 47mfd, 10V
C323	22349101	CD, 100pF, 50V, K
C324	22349221	CD, 220pF, 50V, K
C325, 326	22361470	CD, 47pF, 50V, J
C327	22349221	CD, 220pF, 50V, K
C328	22372333	MY, 0.033mfd, 50V, K
C329	22488109	EL, 1mfd, 50V
C330	22488228	EL, 0.22mfd, 50V
C331	22371153	MY, 0.015mfd, 50V, J
C332	22360544	BL, 0.01mfd, 25V, K
C333	22476479	EL, 4.7mfd, 25V, NP

Symbol No.	Part No.	Description
C334	22473220	EL, 22mfd, 10V, NP
C335, 336	22478109	EL, 1mfd, 50V, NP
C337	22371104	MY, 0.1mfd, 50V, J
C338, 339	22360881	BL, 0.047mfd, 16V, Z
C340, 341	22483101	EL, 100mfd, 10V
C342, 343	22360881	BL, 0.047mfd, 16V, Z
C344, 345	22483101	EL, 100mfd, 10V
C346, 347, 348, 349	22360881	BL, 0.047mfd, 16V, Z
C350	22361270	CD, 27pF, 50V, J
C352	22483101	EL, 100mfd, 10V
C353	22349102	CD, 1000pF, 50V, K
C354	22371823	MY, 0.082mfd, 50V, J
C355	22360584	CD, 2pF, 50V, C, CH
C356	22483470	EL, 47mfd, 10V
C357	22361220	CD, 22pF, 50V, J
C358	22349102	CD, 1000pF, 50V, K
C503	22361509	CD, 5pF, 50V, D
C504, 505	22482102	EL, 1000mfd, 6.3V
C506	22362270	CD, 27pF, 50V, J
C507	22361509	CD, 5pF, 50V, J
C508	22341103	CD, 0.01mfd, 50V, Z
C509	22483101	EL, 100mfd, 10V
C510, 511, 512, 513	22321035	PP, 1800pF, 50V, J
C514	22321084	PP, 180pF, 50V, J
C515	22321058	PP, 1200pF, 50V, J
C516	22371272	MY, 2700pF, 50V, J
C517, 518	22485100	EL, 10mfd, 16V
C519	22371102	MY, 1000pF, 50V, J
C520	22321084	PP, 180pF, 50V, J
C521	22321058	PP, 1200pF, 50V, J
C522	22371272	MY, 2700pF, 50V, J
C523, 524	22485100	EL, 10mfd, 16V
C525	22371102	MY, 1000pF, 50V, J
C526, 527	22371103	MY, 0.01mfd, 50V, J
C528	22445100	EL, 10mfd, 16V
C551, 552	22349331	CD, 330pF, 50V, K
C901	22446101	EL, 100mfd, 25V
C902	22483101	EL, 100mfd, 10V
C903	22485332	EL, 3300mfd, 16V
C904	22485100	EL, 10mfd, 16V
C905	22443471	EL, 470mfd, 10V
C906	22485102	EL, 1000mfd, 16V
C907	22485100	EL, 10mfd, 16V
C908	22443471	EL, 470mfd, 10V
C909	22488479	EL, 4.7mfd, 50V
C910	22443471	EL, 470mfd, 10V
C911	22488479	EL, 4.7mfd, 50V
C912	22443471	EL, 470mfd, 10V
C913	22483101	EL, 100mfd, 10V
C914	22483221	EL, 220mfd, 10V

Symbol No.	Part No.	Description
C915	22485222	EL, 2200mfd, 16V
△ C916	22340150	CD, 4700pF, 400V, M (A, E, Y)
△ C916	22340205	CD, 4700pF, 400V, M (U)
RESISTORS		
All resistors are carbon film 1/6W, ±5% unless otherwise noted. K = 1000, M = 1000000		
R101, 102	22584104	100K ohm
R103, 104	22584471	470 ohm
R105	22570727	2.2K ohm, Metal Film, ±1%
R106	22570719	470 ohm, Metal Film, ±1%
R107	22570735	10K ohm, Metal Film, ±1%
R108	22570737	15K ohm, Metal Film, ±1%
R109	22584563	56K ohm
R110	22584102	1K ohm
R111	22570703	22 ohm, Metal Film, ±1%
R112	22584102	1K ohm
R113	22584103	10K ohm
R201, 202, 203, 204, 205	22584274	270K ohm
R206, 207, 208, 209, 210, 211, 212	22584392	3.9K ohm
R213, 214, 215, 216	22584222	2.2K ohm
R217, 218, 219	22584222	2.2K ohm
R220, 221, 222, 223, 224, 225, 226	22584330	33 ohm
R301	22540782	2.2K ohm x 4, Composite Resistor
R302	22540781	5.6K ohm x 6, Composite Resistor
R303	22584222	2.2K ohm
R304	22584682	6.8K ohm
R305	22547339	3.3 ohm, 1/2W
R306	22584183	18K ohm
R308	22584224	220K ohm
R309	22658884	100K ohm, Semi-fixed Variable

Symbol No.	Part No.	Description
R310	22584184	180K ohm
R311	22584683	68K ohm
R313	22584153	15K ohm
R314	22584333	33K ohm
R316	22584564	560K ohm
R317	22584151	150 ohm
R318	22584102	1K ohm
R319	22584104	100K ohm
R320, 321	22584822	8.2K ohm
R322	22584103	10K ohm
R323	22584223	22K ohm
R324	22584824	820K ohm
R325, 326	22584123	12K ohm
R327	22584103	10K ohm
R328	22584154	150K ohm
R329	22584682	6.8K ohm
R330	22584103	10K ohm
R331	22584681	680 ohm
R332	22584822	8.2K ohm
R333	22584153	15K ohm
R334	22584392	3.9K ohm
R335	22584682	6.8K ohm
R336	22584683	68K ohm
R337	22658884	100K ohm, Semi-fixed Variable
R338	22584225	2.2M ohm
R339	22658884	100K ohm, Semi-fixed Variable
R340	22584183	18K ohm
R341	22584682	6.8K ohm
R342	22658901	20K ohm, Semi-fixed Variable
R343	22584223	22K ohm
R344	22584103	10K ohm
R345	22584104	100K ohm
R346	22584225	2.2M ohm
R347	22584473	47K ohm
R348	22584472	4.7K ohm
R349	22584103	10K ohm
R350	22584472	4.7K ohm
R351	22584152	1.5K ohm
R352	22584103	10K ohm
R353	22584333	33K ohm
R354	22584155	1.5M ohm
R355	22584562	5.6K ohm
R356	22584272	2.7K ohm
R357	22584473	47K ohm
R358	22584153	15K ohm
R359	22584101	100 ohm
R360	22584183	18K ohm
R361	22584224	220K ohm
R362	22584104	100K ohm
R363	22584683	68K ohm

CAUTION: The Δ mark, the symbol No. circled, designate components which have s with types indential to those in the

A
B
C
D
E
F

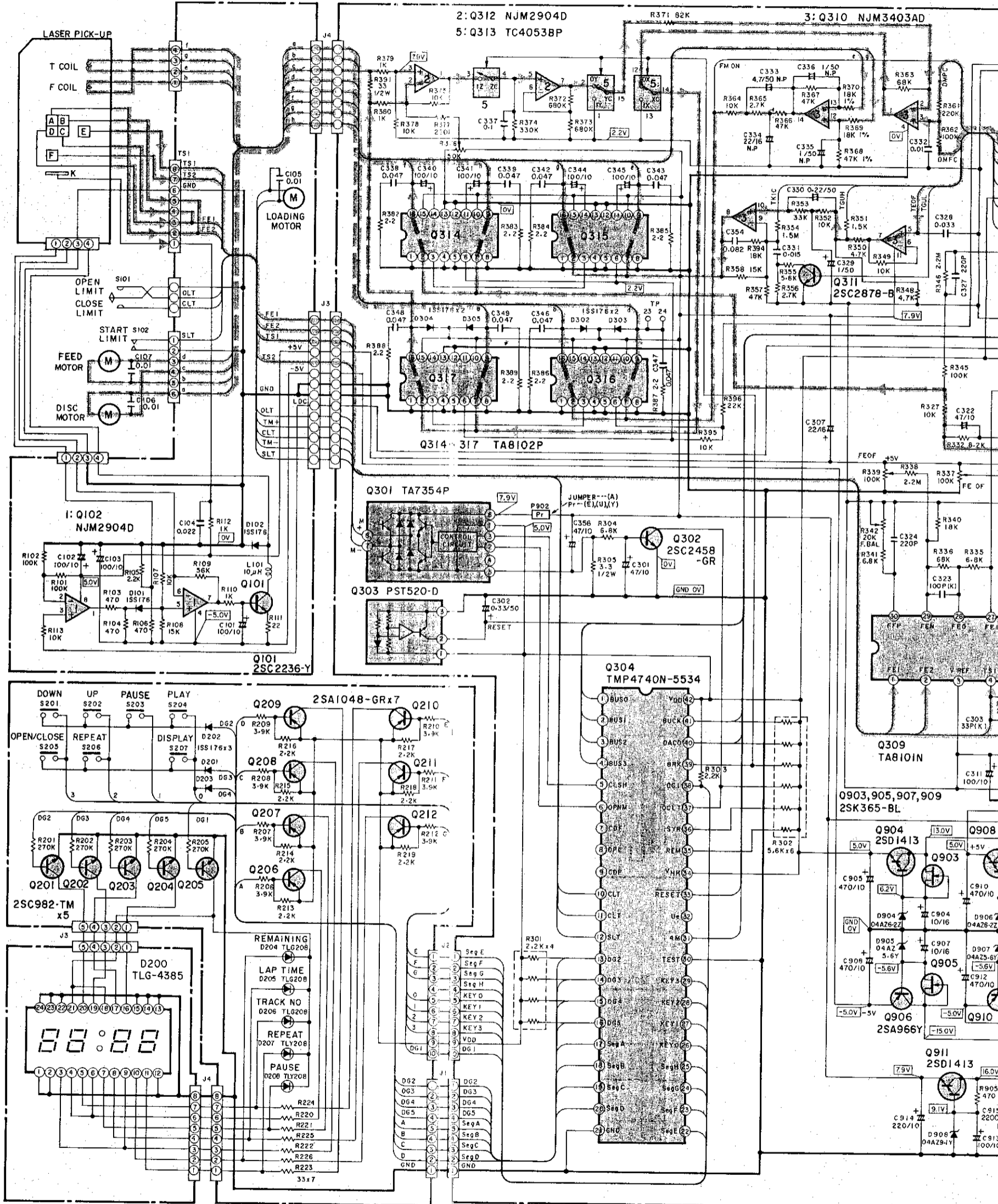

1 2 3 4

CHEMATIC DIAGRAM

circled with oval in the schematic diagram and the shaded area in the parts list have special characteristics important for safety and should be replaced only in the original circuit or specified in the parts list.

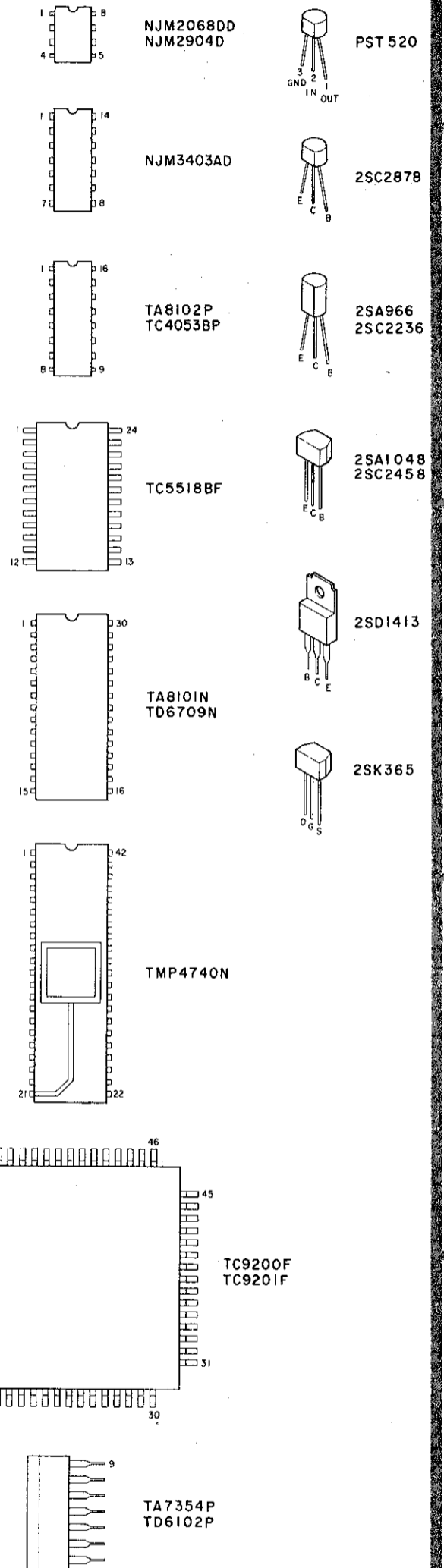
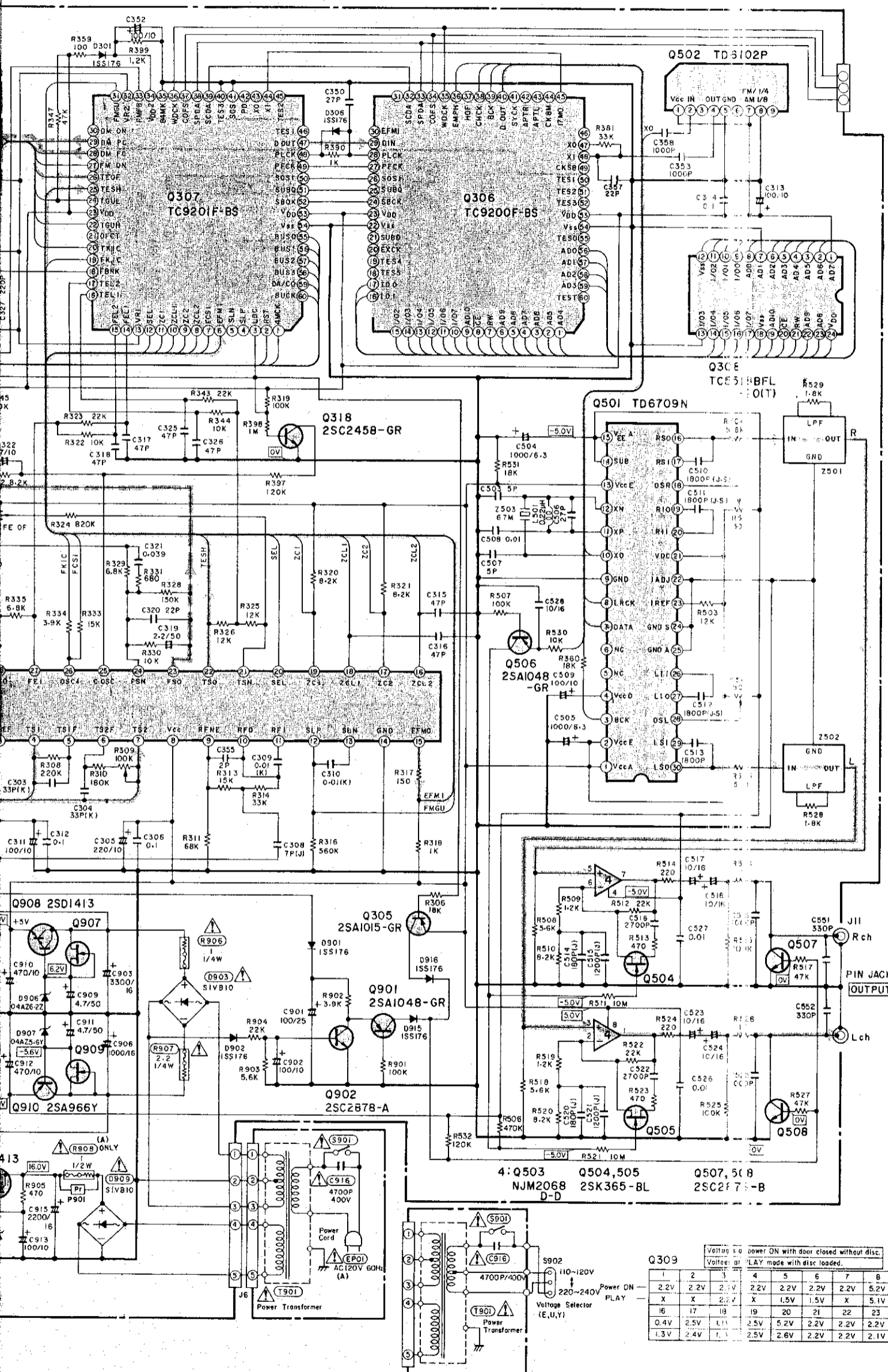

Q309 Voltage Selector

Voltage Selector		Power ON with door closed without disc.																											
Voltage Selector		LAY mode with disc loaded.																											
		X Do not touch during PLAY.																											
1	2.2V	2	2.2V	3	2.2V	4	2.2V	5	2.2V	6	2.2V	7	2.2V	8	5.2V	9	2.3V	10	0.9V	11	2.2V	12	2.0V	13	2.1V	14	0V	15	5.2V
X	X	X	X	X	X	X	X	X	X	X	X	X	X	X	X	X	X	X	X	X	X	X	X	X	X	X	X	X	X
16	0.4V	17	2.5V	18	1.1V	19	2.5V	20	5.2V	21	2.2V	22	2.2V	23	2.2V	24	2.2V	25	2.2V	26	2.7V	27	2.2V	28	2.2V	29	2.2V	30	2.2V
1.3V	2.4V	1.1V	2.5V	2.6V	2.2V	2.2V	2.1V	2.2V	2.1V	2.2V	2.1V	2.2V	2.2V	2.1V	2.2V	2.1V	2.2V	2.1V	2.2V	2.2V	2.1V	2.2V	2.1V	2.2V	2.1V	2.2V	2.1V	2.2V	

- | | | | | |
|------------|------------------------|----------|----------------------------------|------|
| Switch No. | Switch Name | Position | S204: Play (SCAN) Switch | OFF |
| S101: | Tray Open/Close Switch | OFF | S205: Open, Close (Eject) Switch | OFF |
| S102: | Start Limit Switch | OFF | S206: Repeat Switch | OFF |
| S201: | Skip (Down) Switch | OFF | S207: Display Switch | OFF |
| S202: | SCAN (Up) Switch | OFF | S901: Power Switch | OFF |
| S203: | Pause (STOP) Switch | OFF | S902: Voltage Selector Switch | 120V |

NAD 5330

PRINTED IN JAPAN Apr., 1986

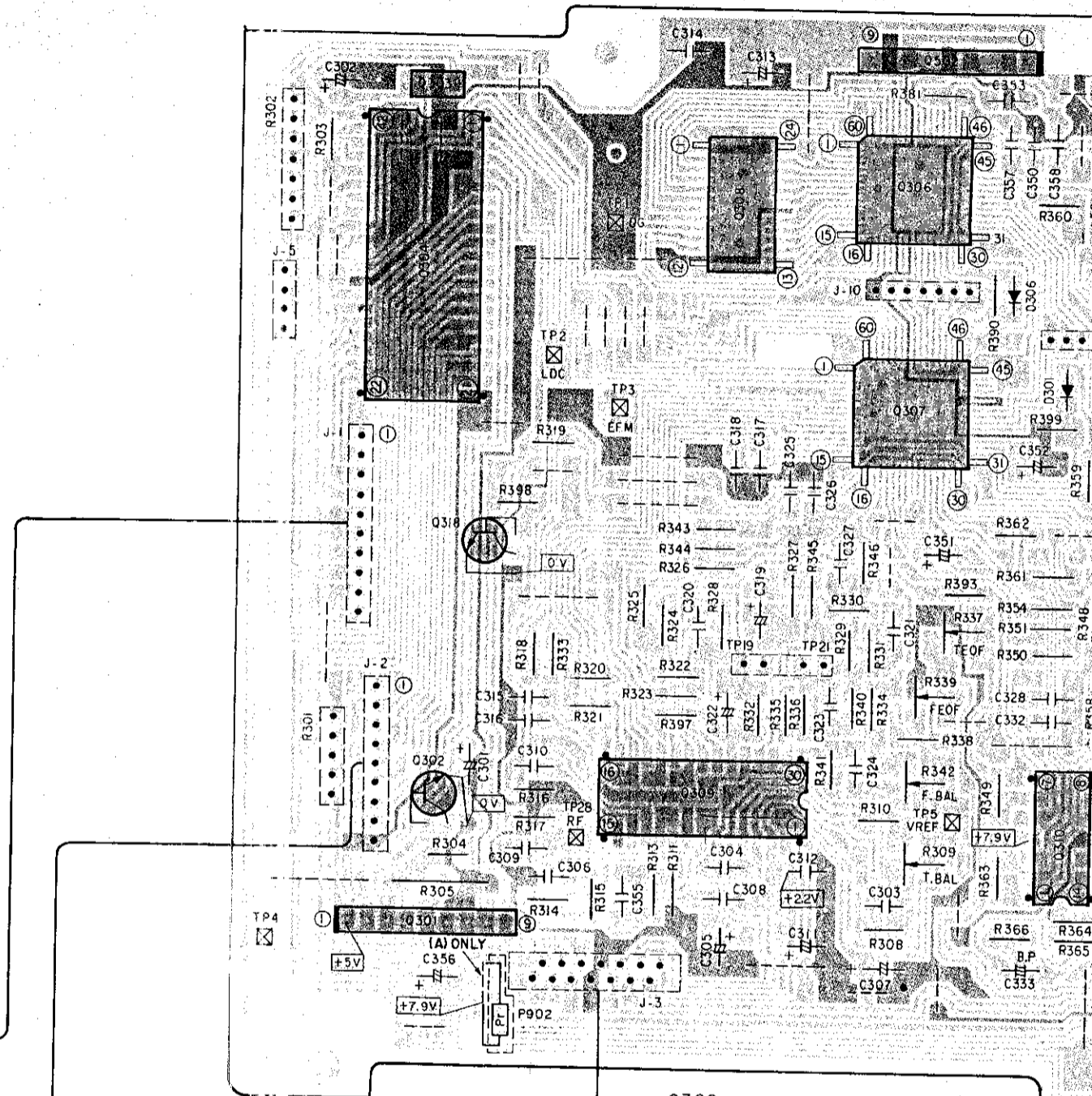
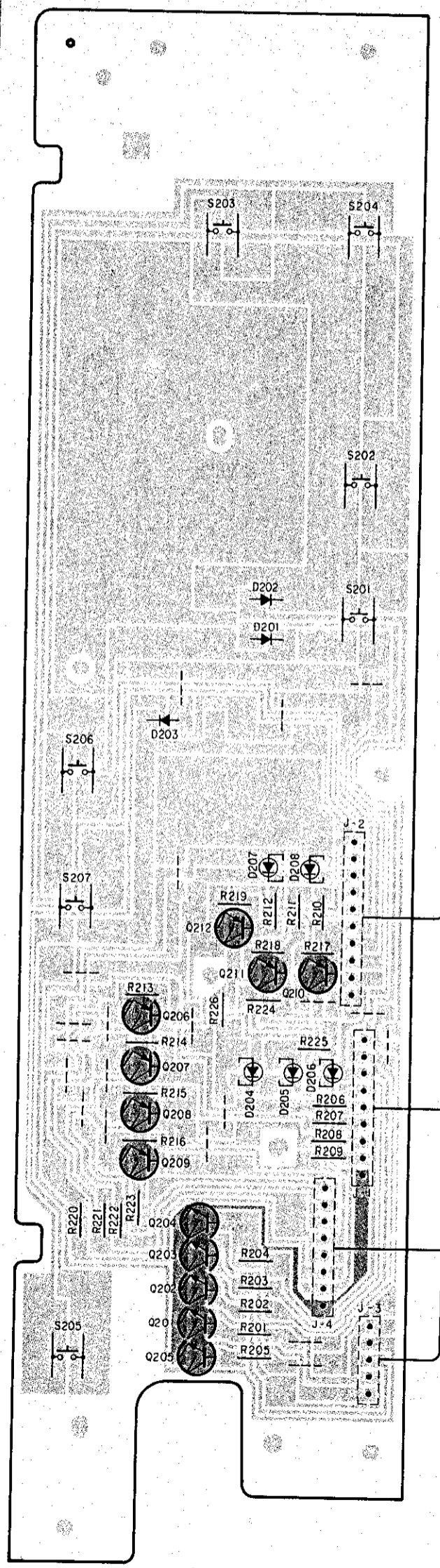
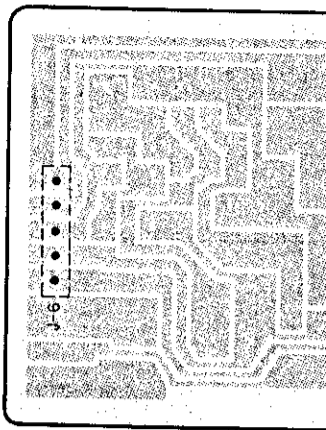

Voltages at power on with door closed without disc.
 Voltages at PLAY made with disc loaded.

Q309 X Do not touch when play.

	1	2	3	4	5	6	7	8
Power ON	2.2V	2.2V	2.2V	2.2V	2.2V	2.2V	2.2V	5.2V
Play	X	X	2.2V	X	1.5V	1.5V	X	5.1V
Power ON	0.4V	2.5V	1.1V	2.5V	5.2V	2.2V	2.2V	2.2V
Play	1.3V	2.4V	1.1V	2.5V	2.6V	2.2V	2.2V	2.1V

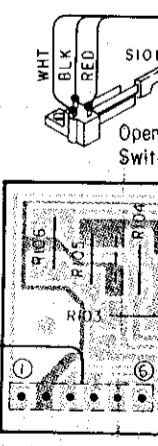
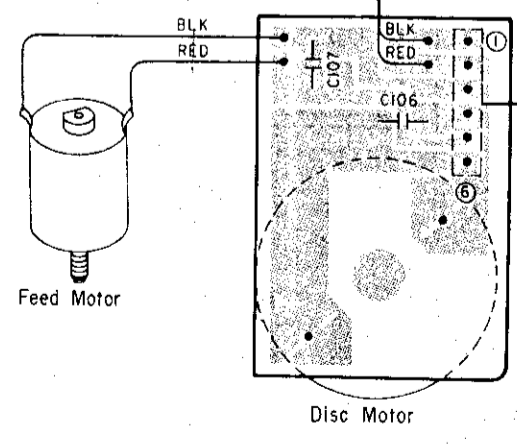
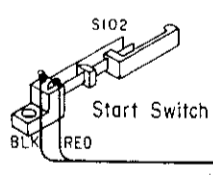

A

B

C

D

E

F

1

2

3

4

TRICAL PARTS LOCATIONS

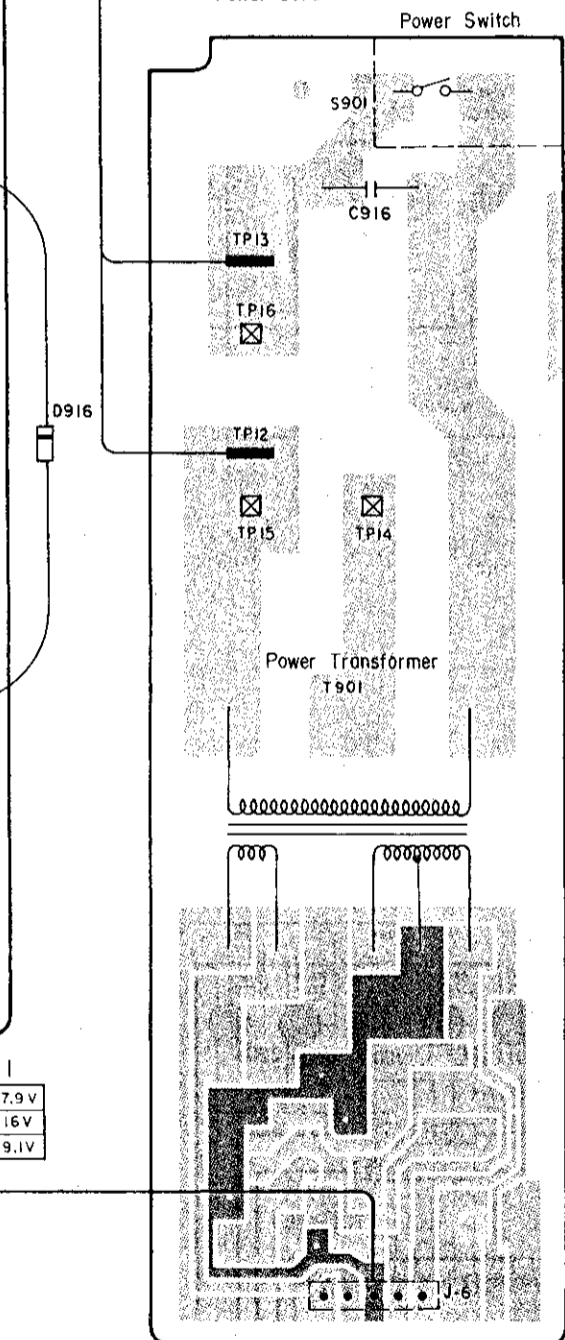
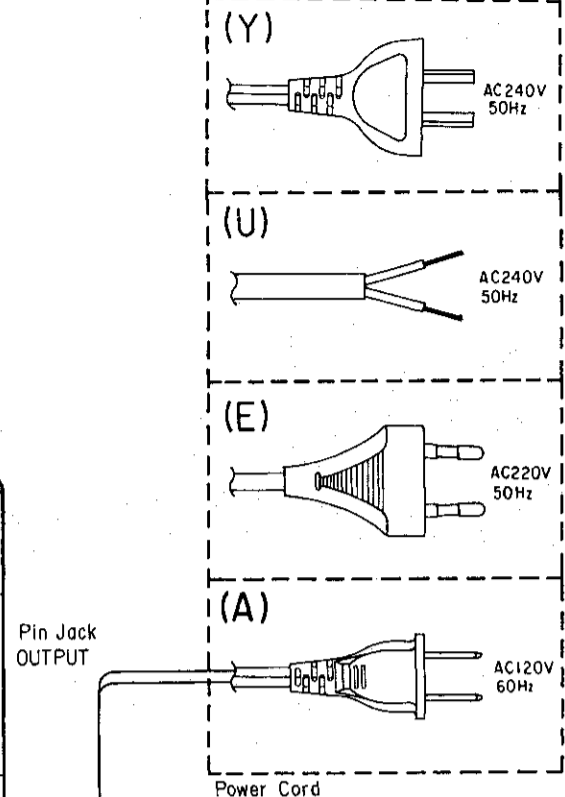
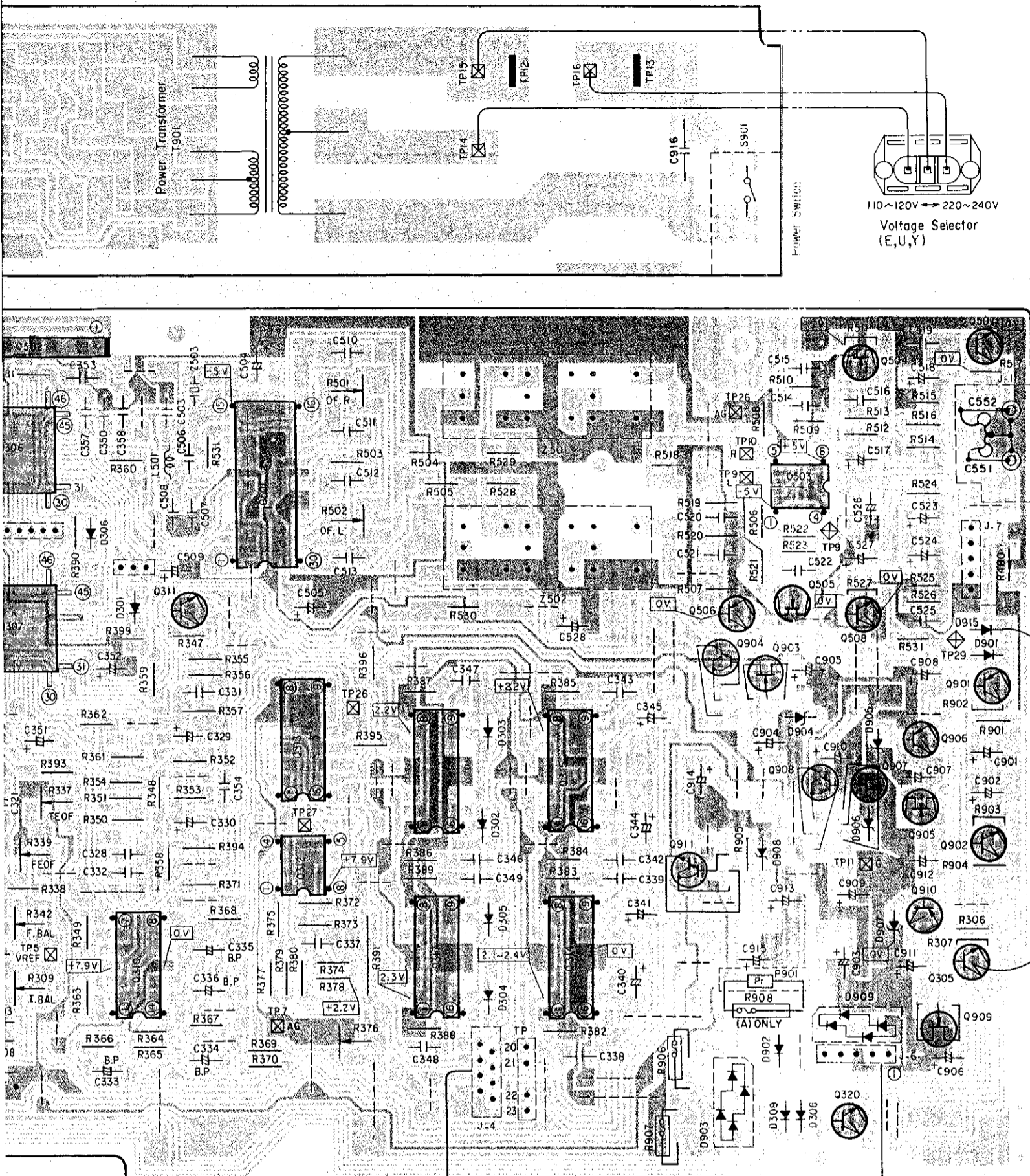

5	6	7	8	9	10	11	12	13	14	15
2.2V	2.2V	2.2V	5.2V	2.3V	0.9V	2.2V	2.0V	2.1V	0V	5.2V
1.5V	1.5V	X	5.1V	X	1.8V	2.2V	2.2V	X	0V	2.5V
20	21	22	23	24	25	26	27	28	29	30
2.2V	2.2V	2.2V	2.2V	2.2V	2.2V	2.7V	2.2V	2.2V	2.2V	2.2V
0.6V	2.2V	2.2V	2.1V	2.2V	2.1V	2.6V	2.2V	2.2V	2.1V	2.1V

Q304, Q908	Q906, Q910	Q911
E +5V	E -5V	E +7.9V
C +13V	C -15V	C +16V
B +6.2V	B -5.6V	B +9.1V

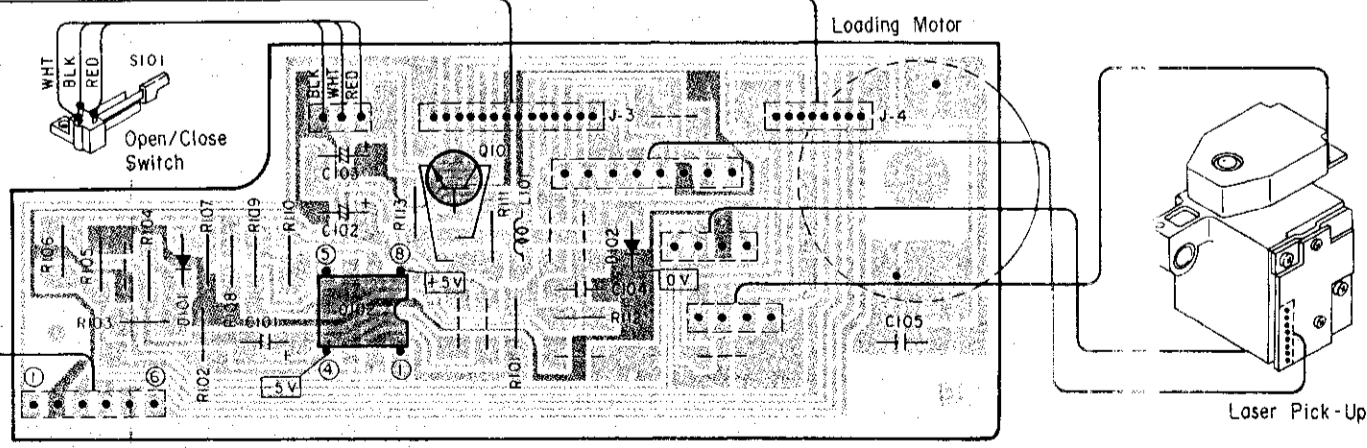

Symbol No.	Part No.	Description
R364	22584103	10K ohm
R365	22584272	2.7K ohm
R366	22584473	47K ohm
R367, 368	22570743	47K ohm, Metal Film, ±1%
R369, 370	22570738	18K ohm, Metal Film, ±1%
R371	22584823	82K ohm
R372, 373	22584684	680K ohm
R374	22584334	330K ohm
R375	22584103	10K ohm
R376	22658889	50K ohm, Semi-fixed Variable
R377	22584224	220K ohm
R378	22584103	10K ohm
R379, 380	22584102	1K ohm
R381	22584333	33K ohm
R382, 383, 384, 385, 386, 387, 388, 389	22584229	2.2 ohm
R390	22584102	1K ohm
R391	22547339	3.3 ohm, 1/2W
R394	22584183	18K ohm
R395	22584103	10K ohm
R396	22584223	22K ohm
R397	22584124	120K ohm
R398	22584105	1M ohm
R399	22584122	1.2K ohm
R501, 502	22658889	50K ohm, Semi-fixed Variable
R503	22584123	12K ohm
R504, 505	22584562	5.6K ohm
R506	22584474	470K ohm
R507	22584104	100K ohm
R508	22584562	5.6K ohm
R509	22584122	1.2K ohm
R510	22584822	8.2K ohm
R511	22555106	10M ohm, 1/4W
R512	22584223	22K ohm
R513	22584471	470 ohm
R514	22584221	220 ohm
R515	22584104	100K ohm
R516	22584102	1K ohm
R517	22584473	47K ohm
R518	22584562	5.6K ohm
R519	22584122	1.2K ohm
R520	22584822	8.2K ohm
R521	22555106	10M ohm, 1/4W
R522	22584223	22K ohm
R523	22584471	470 ohm
R524	22584221	220 ohm
R525	22584104	100K ohm
R526	22584102	1K ohm
R527	22584473	47K ohm

△
△
△

Symbol No.	Part No.	Description
R528, 529	22584182	1.8K ohm
R530	22584103	10K ohm
R531	22584183	18K ohm
R532	22584124	120K ohm
R901	22584104	100K ohm
R902	22584392	3.9K ohm
R903	22584562	5.6K ohm
R904	22584223	22K ohm
R905	22584471	470 ohm
R906	22500166	1 ohm, 1/4W, Fusible
R907	22500167	2.2 ohm, 1/4W, Fusible
R908	22500201	1 ohm, 1/2W, Fusible
ACCESSORIES		
AC01	22904994	Owner's Manual (A)
AC01	22904995	Owner's Manual (E, U, Y)
AC02	22164775	Connection Cord