

NAD **SERVICE**
MANUAL

5320

5325

COMPACT
DISC PLAYERS



CAUTION - HAZARDOUS LASER AND ELECTROMAGNETIC RADIATION WHEN OPEN AND INTERLOCK DEFEATED.

ATTENTION - RAYONNEMENT LASER ET ELECTROMAGNETIQUE DANGEREUX SI OUVERT AVEC L'ENCLenchement DE SECURITE ANNULE.

DANGER - INVISIBLE LASER RADIATION WHEN OPEN AND INTERLOCK FAILED OR DEFEATED.
AVOID DIRECT EXPOSURE TO BEAM.

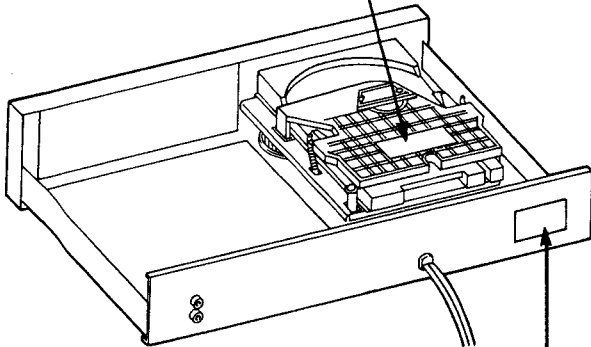

THIS PRODUCT COMPLIES WITH
DHHS RULES 21 CFR SUBCHAPTER
J PART 1040.10 AND 1040.11 AT DATE
OF MANUFACTURE.

MANUFACTURED: BEY

**Before Using
CD Player**

Remove three SHIPPING SCREWS (red screws) located on the bottom of the unit.
The removed screws should be retained in case any subsequent transportation of the unit is required.

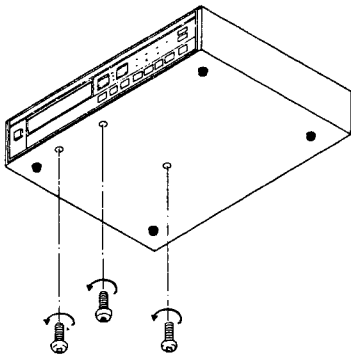

CAUTION - INVISIBLE LASER RADIATION WHEN OPEN AND INTERLOCKS DEFEATED. AVOID EXPOSURE TO BEAM.

VORSICHT! UNSICHTBARE LASERSTRAHLUNG TRITT AUS, WENN DECKEL GEÖFFNET UND WENN SICHERHEITSVERRIEGELUNG ÜBERBRÜCKT IST. NICHT DEM STRAHL AUSSETZEN!

VARNING - OSYNLIG LASERSTRÅLNING NÄR DENNA DEL ÄR ÖPPNAD OCH SPÄRR ÄR URKOPPLAD. STRÅLEN ÄR FARLIG.

ADVARSEL - USYNLIG LASERSTRÅLNING VED ÅBNING, NÄR SIKKERHEDSAFBRYDERE ER UDE AF FUNKTION. UNDGÅ UDSÆTTELSE FOR STRÅLING.

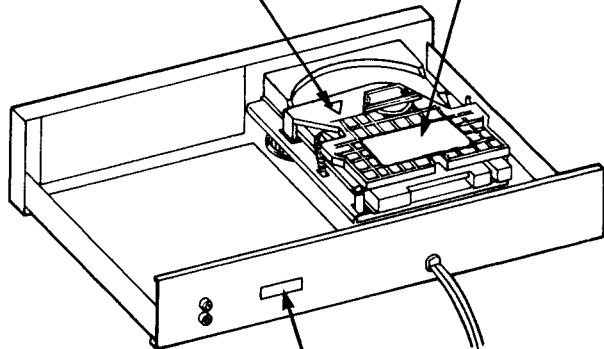

CLASS 1 LASER PRODUCT

PAGE	CONTENTS
2	Safety Information
3	Caution, Specification
4	Rear/Front View
5	Cabinet Removal, Installation
6	Alignment Method
9	Play Flow Chart
10	Troubleshooting Guide
12	IC Description
19	Block Diagram
21	Schematics, PCB Layouts
32	Exploded Views, Part Lists

Cautions on Replacement of Pick-up

1. Do not touch the terminals on the pick-up with your hand when removing the laser pick-up.
2. Cover the working bench with a conductive mat which is also grounded.
3. Before proceeding , always touch the conductive mat or ground lead with your both hands to discharge electric charges developed on your body.
4. To protect your vision do not expose your eyes to the direct laser light. The beam is focused at a distance of 2 mm from the lens.

SPECIFICATIONS

	Nominal	Limit	Unit		
Decoding	: 16-bit linear two channels			Remote Control	: 5325 only
Frequency response (8 Hz-20 kHz)	+0.2 -2.0	+1.0 -3.0	dB	Power Consumption	: 0.11A (for A,A1) 14 W (for B,B1,C,C1,C2)
De-emphasis error	+0.5 -1	+1.0 -2.0	dB	Dimensions	: Width 420 mm (16.54 in.) Height 87 mm (3.43 in.) Depth 231 mm (9.09 in.)
Output level at 0 dB	: 2 volts \pm 0.7			Net weight	: 3 kg (6.6 lb)
Harmonic Distortion (W/20 kHz L.P.F at 1 kHz, 0 dB)	0.04	0.07	%	A	: USA
Signal-to-Noise Ratio (W/20 kHz L.P.F)	96	90	dB	A1	: CANADA
Channel Separation (W/20 kHz L.P.F at 1 kHz)	80	70	dB	B	: U.K.
Channel Balance (at 1 kHz 0 dB)	0.1	1.0	dB	B1	: AUSTRALIA/N.Z.
Wow and Flutter	: Unmeasurable (quartz crystal accuracy)			C	: EUROPE & OTHERS
				C1	: W.GERMANY
				C2	: G.P.M.

REAR PANEL

1. Line Output Jacks.
2. AC Line Cord.

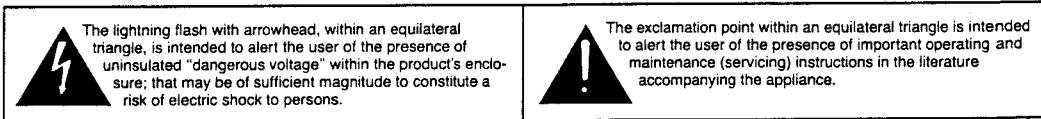
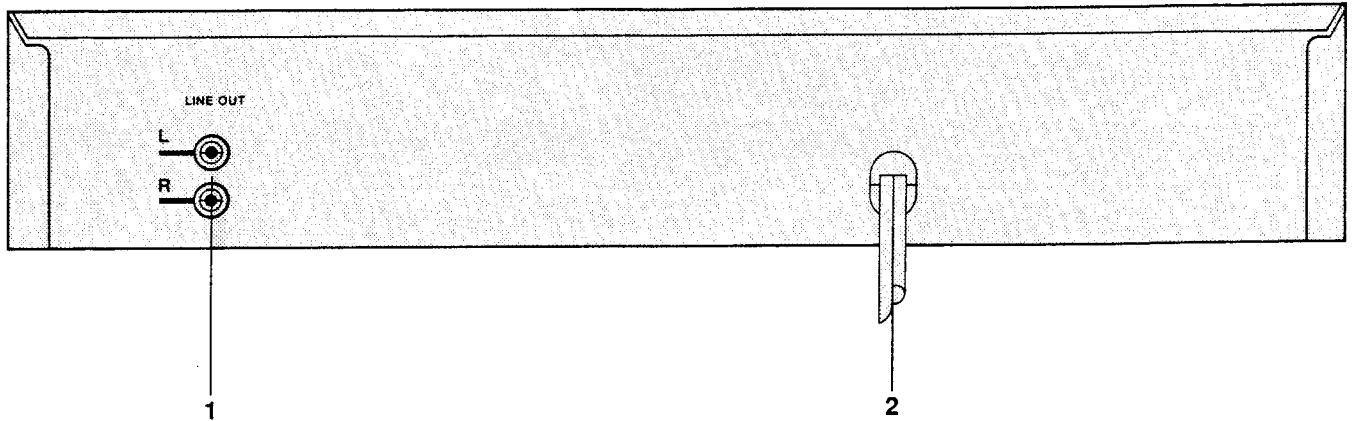
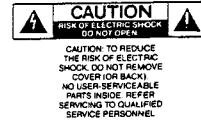

FRONT PANEL

- | | |
|------------------------|-------------------------|
| 1. Power On/Off. | 8. Clear.* |
| 2. Disc Drawer. | 9. Skip Forward/Back.* |
| 3. Open/Close. | 10. Reset.* |
| 4. Display Selector.* | 11. Play/Pause.* |
| 5. Repeat.* | 12. Display.* |
| 6. Scan Forward/Back.* | 13. Remote (5325 only). |
| 7. Memory.* | |

* – Also via remote (5325 only)

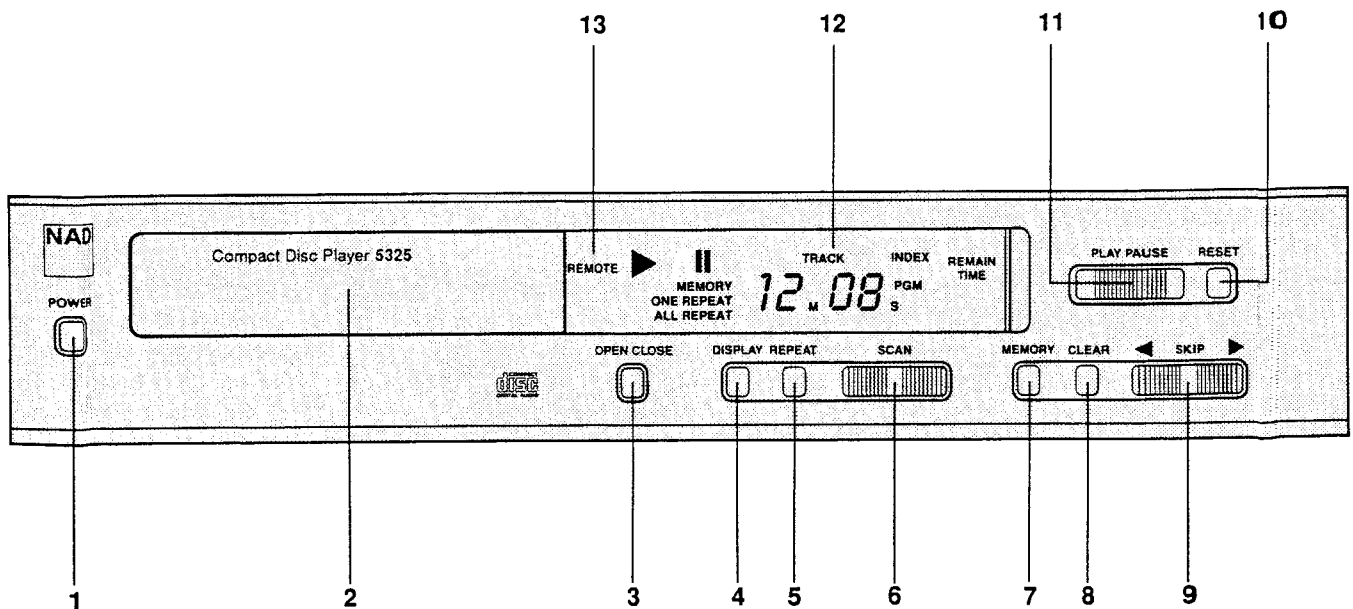

CABINET REMOVAL/INSTALLATION

Removal

1. Remove 3 screws from rear.

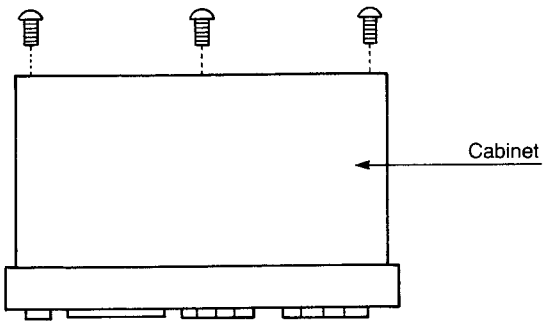

2. Lift rear edge of cabinet, and remove tabs A outward from chassis slots.

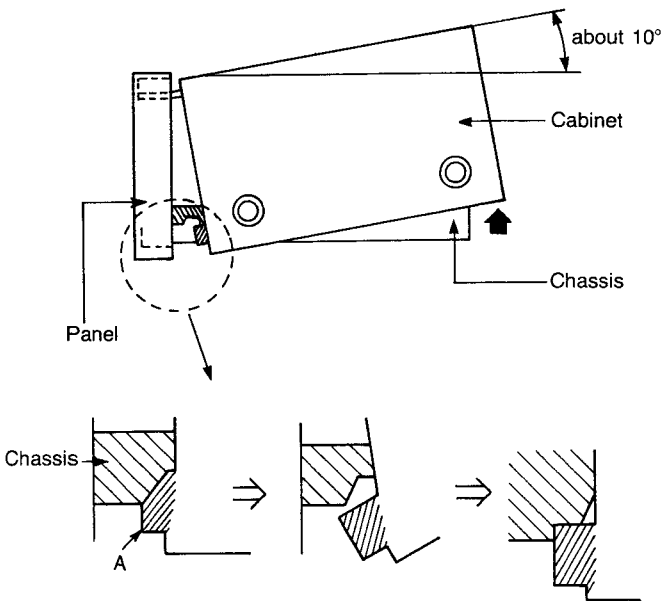

3. While holding front panel down, lift both sides C upward, and push cabinet to rear.

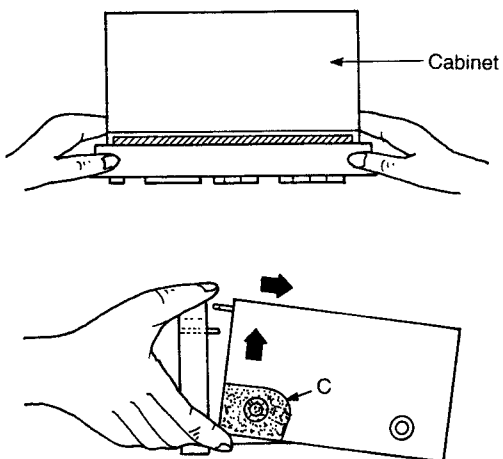

Installation

1. Lift rear edge of cabinet, and insert tab B into front panel.

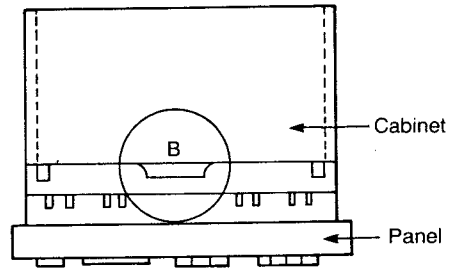

2. Press holes D tight to chassis, and insert tabs A fully into chassis slots.

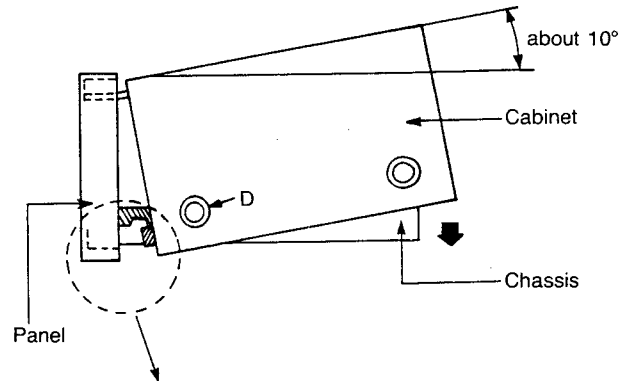

3. Install 3 screws into rear.

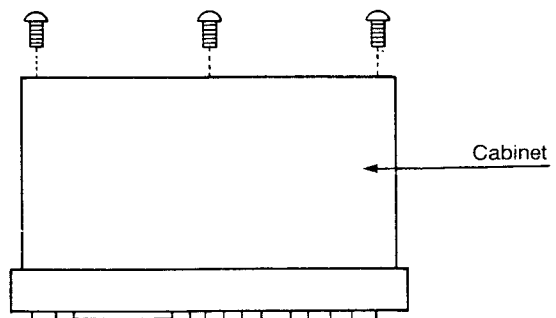

ALIGNMENT METHOD

Equipment Needed:

- Oscilloscope, 2 channel, 35 MHz minimum
- AF Oscillator
- Laser power meter (e.g. Leader LPM-8000)
- AC voltmeter, 2 channel
- Frequency counter
- Test disc, high quality (e.g. Sony YEDS-18, CBS CD-1, etc.)
- Jigs (as shown):
 - Low-pass filter (LPF)
 - Band-pass filter (BPF)

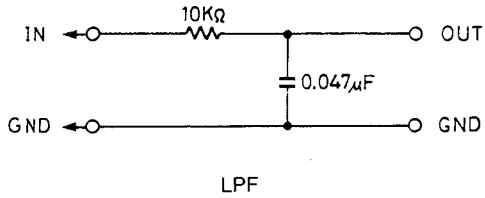

LPF

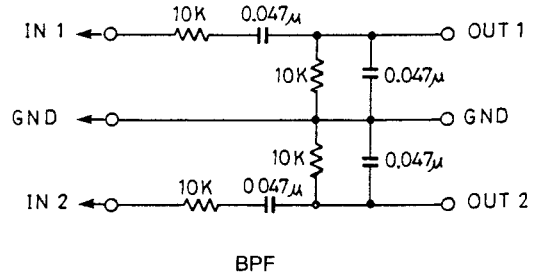

BPF

P.C.B Test Point

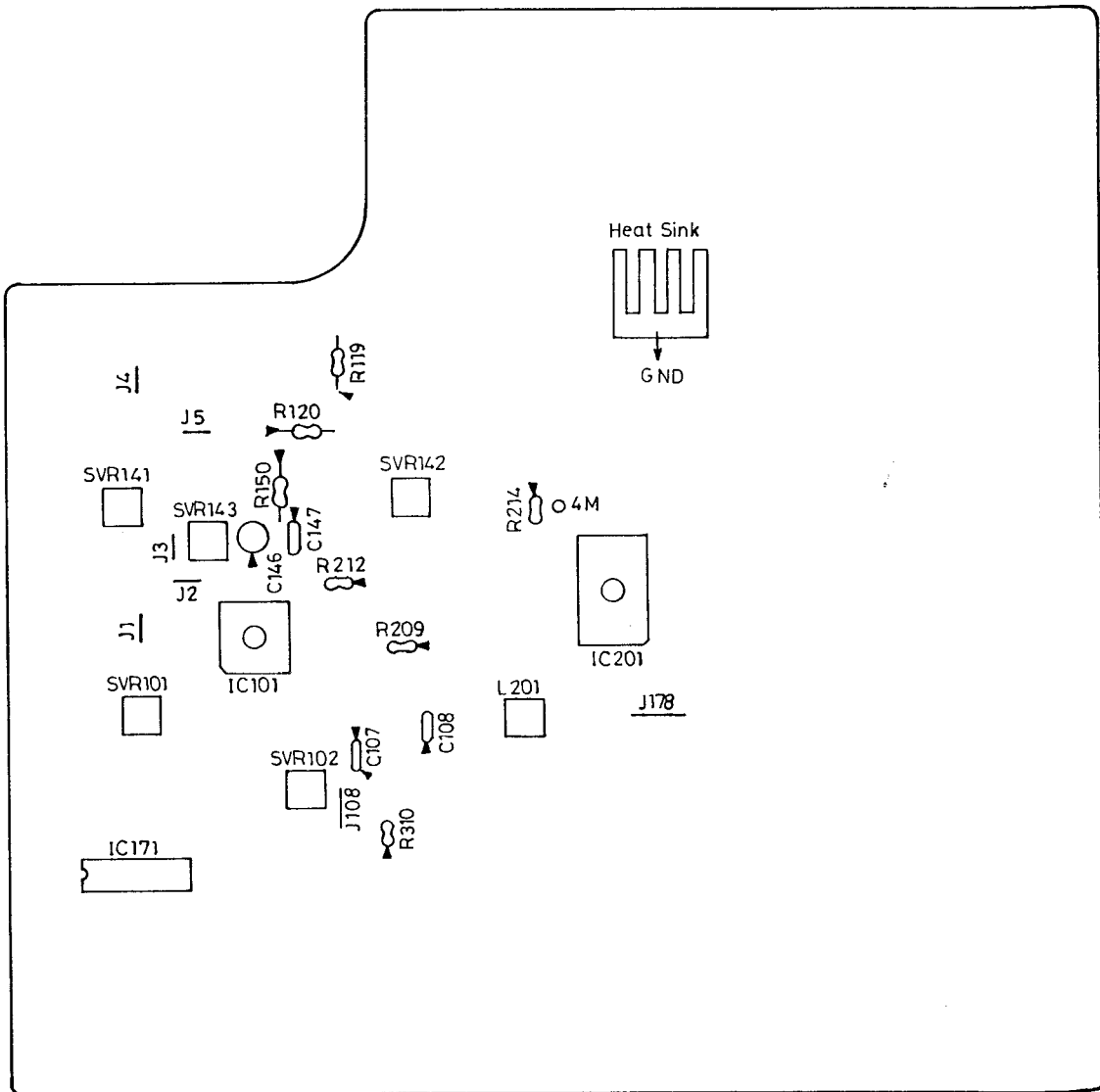

Alignment Method:

1. Laser Output Check (disc out)

1. Apply power meter sensor to pickup.
2. Switch Power ON, and check meter during 5 seconds focus search for laser output = 0.08 - 0.3 mW (0.12 mW typical).

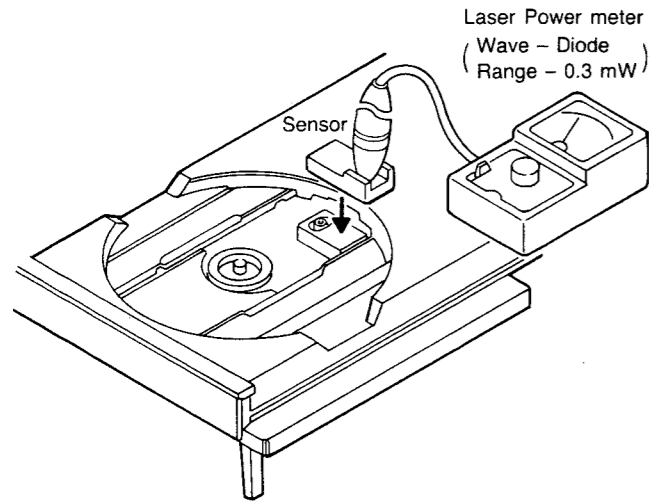

2. Focus Search Signal Check (disc out)

Scope setting:
V: 1.0 V/div, DC in
H: 0.5-1.0 sec/div

1. Connect scope to J4 (FC).
2. Switch power ON, and check focus search wave; also check for smooth movement of lens.

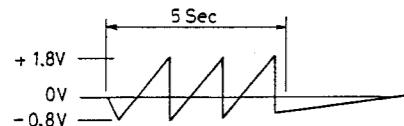

3. Focus Offset Adjustment (disc out)

(Note: DVM may be used)
Scope setting (use LPF):
V: 10 mV/div, DC in

1. Connect scope to J4 (FC).
2. Leave power ON minimum 30 sec.
3. Adjust SVR101 for 0 ± 10 mV DC.

4. Tracking Offset Adjustment (disc out)

(Note: DVM may be used)
Scope setting (use LPF):
V: 10 mV/div, DC in

1. Connect scope to J5 (TC).
2. Connect R212 (TOFF) to GND.
3. Adjust SVR142 for 0 ± 10 mV DC.

5. E-signal Same Pit Check (disc in)

(This checks that 3 beams are all on same track)

Scope setting:
CH1: 0.5 V/div, AC in
CH2: 0.05 V/div, AC in
H: 2 μ Sec/div
TRIG: CH1, bottom part of wave

1. Connect scope: CH1 to C108 (RF); CH2 to J1 (E).
2. Press PLAY (music part of disc), and check wave.

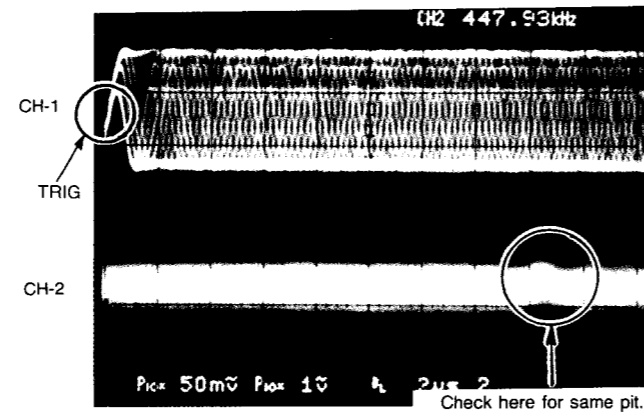

6. Diffraction Grating Check (disc in)

Scope setting (use BPF):
X/Y: 20 mV/div, DC in

1. Connect scope: X (hor) to J1 (E), Y (vert) to J2 (F).
2. Press PLAY, then SKIP to move laser to middle of disc.
3. Connect C147 (TOFS) to GND (tracking off), and check Lissajous wave. (max error 45 degrees)

GOOD

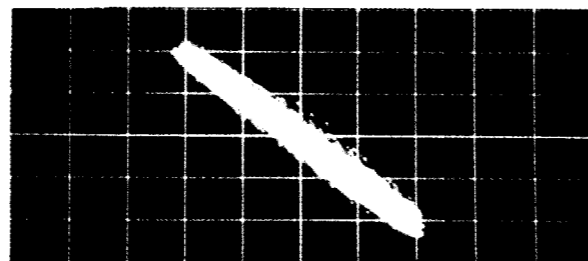

LIMIT MAX (45°)

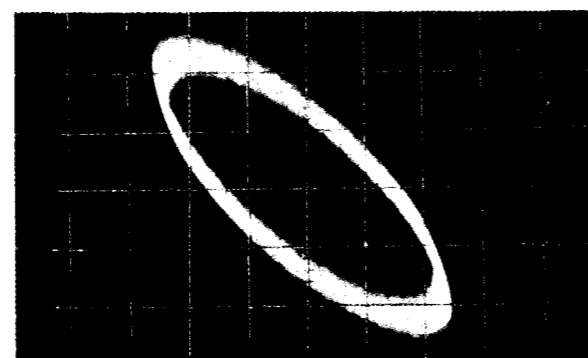

INCORRECT (90°)

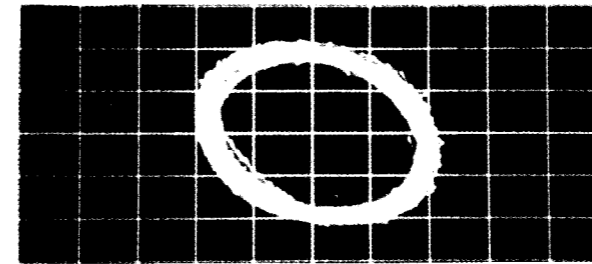

INCORRECT (180°)

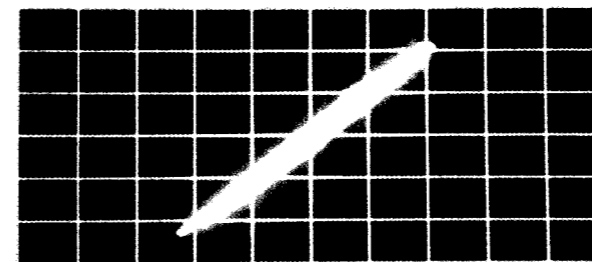

7. E/F Balance Adjustment (disc in)

Scope setting:
V: 0.5 V/div, DC in
H: 5 mSec/div (or sweep stop)

1. Connect scope to J3 (TE).
2. Connect R214 (DEMO) to J178 (+5 V), then press PLAY.
3. Connect C147 (TOFS) to GND (tracking off).
4. Connect R310 to GND (LASER ON).
5. Adjust SVR141 for $0 \text{ V} \pm 150$ mV unbalance (offset).

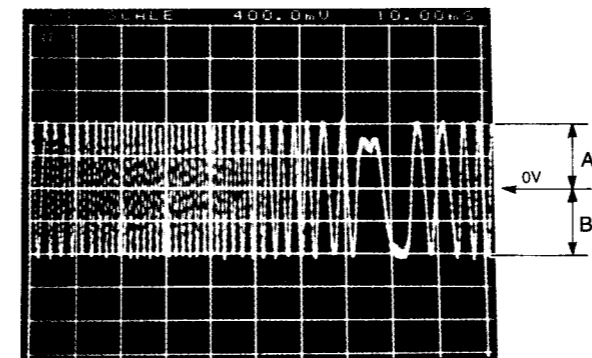

Adjust for $A = B \pm 150$ mV

8. Focus Gain Adjustment (disc in)

1. Connect 2CH AC VM (use BPF): CH1 to J4 (FC), CH2 to J108 (FSW).
2. Press PLAY.
3. Connect AF Osc (1 kHz, 1.5 Vrms) to R119, through 220K resistor.
4. Adjust SVR102; first for CH1 maximum, then for CH1-CH2 = 13 ± 1 dB.

9. Tracking Gain Adjustment (disc in)

1. Connect 2CH AC VM (use BPF): CH1 to J5 (TC), CH2 to C146 (TPRO).
2. Press PLAY.
3. Connect AF Osc (1.2 kHz, 250 mVrms) to R150, through 220K resistor.
4. Adjust SVR143; first for CH1 maximum, then for CH1-CH2 = 5 ± 1 dB.

10. VCO Adjustment (disc in or out)

1. Connect frequency counter to 4M (FSEQ/PCK).
2. Press RESET (stop).
3. Adjust L201 for 4.3218 ± 0.01 MHz.

NOTES:

FAILURE OF CHECKS:

1. Failure of Laser Output Check means that characteristic of laser diode or output monitor diode has changed; complete failure may occur soon. Adjustment is not recommended, laser pickup assy should be replaced.
2. Failure of E-signal Same Pit Check means diffraction grating severely misaligned; failure of Diffraction Grating Check means less-severely misaligned. This may result in poor tracking (skip). Since this is usually caused by damage to laser pickup assy, it should be replaced. (Adjustment is not recommended. It requires to do both checks at same time, using two scopes; and is usually not successful.)

DEMO PLAY STATE:

Connect R214 (DEMO) to J178 (+5 V), then press PLAY. The system is brought into Play state by LSI (not by microcomputer). In this case, the system can not be turned off even if tracking servo is stopped.

This is necessary for E/F Balance adjustment, and can also be helpful when troubleshooting for cause of problems.

PLAY FLOW CHART

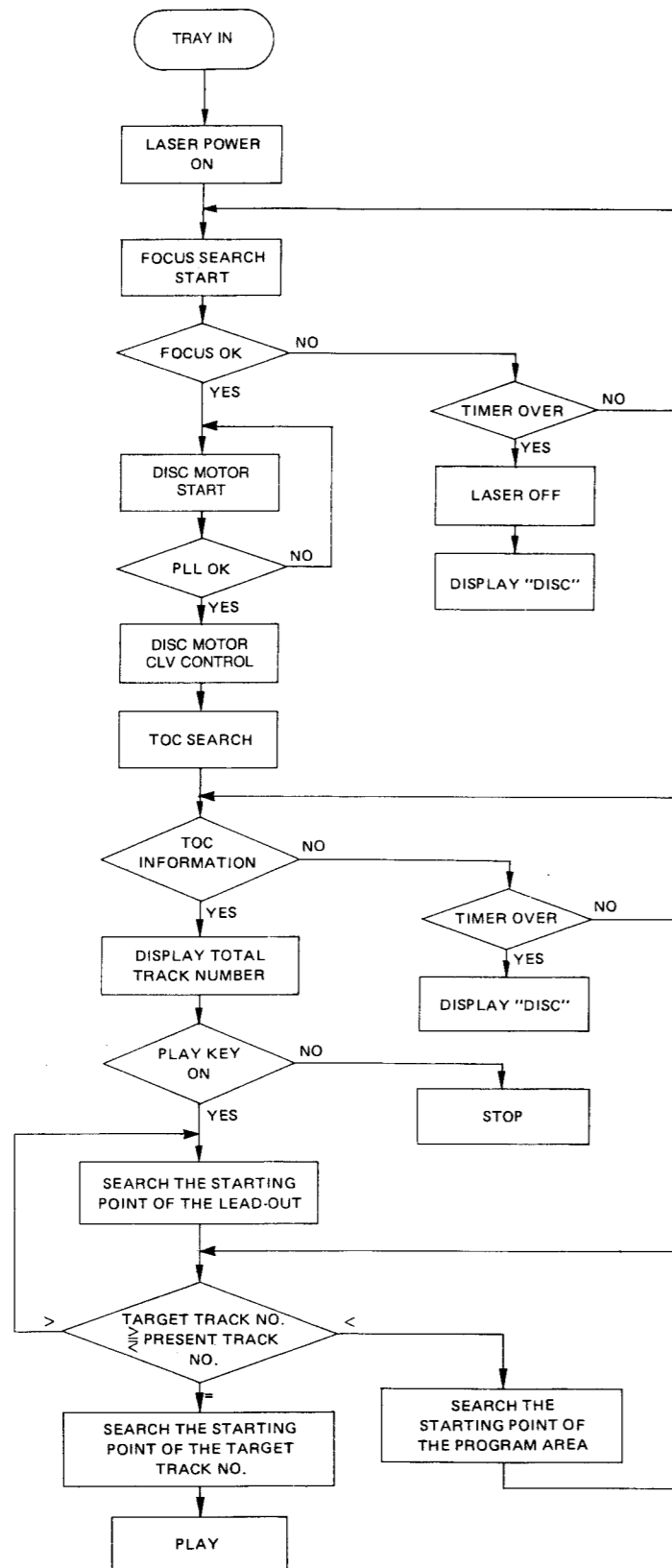

TROUBLESHOOTING GUIDE

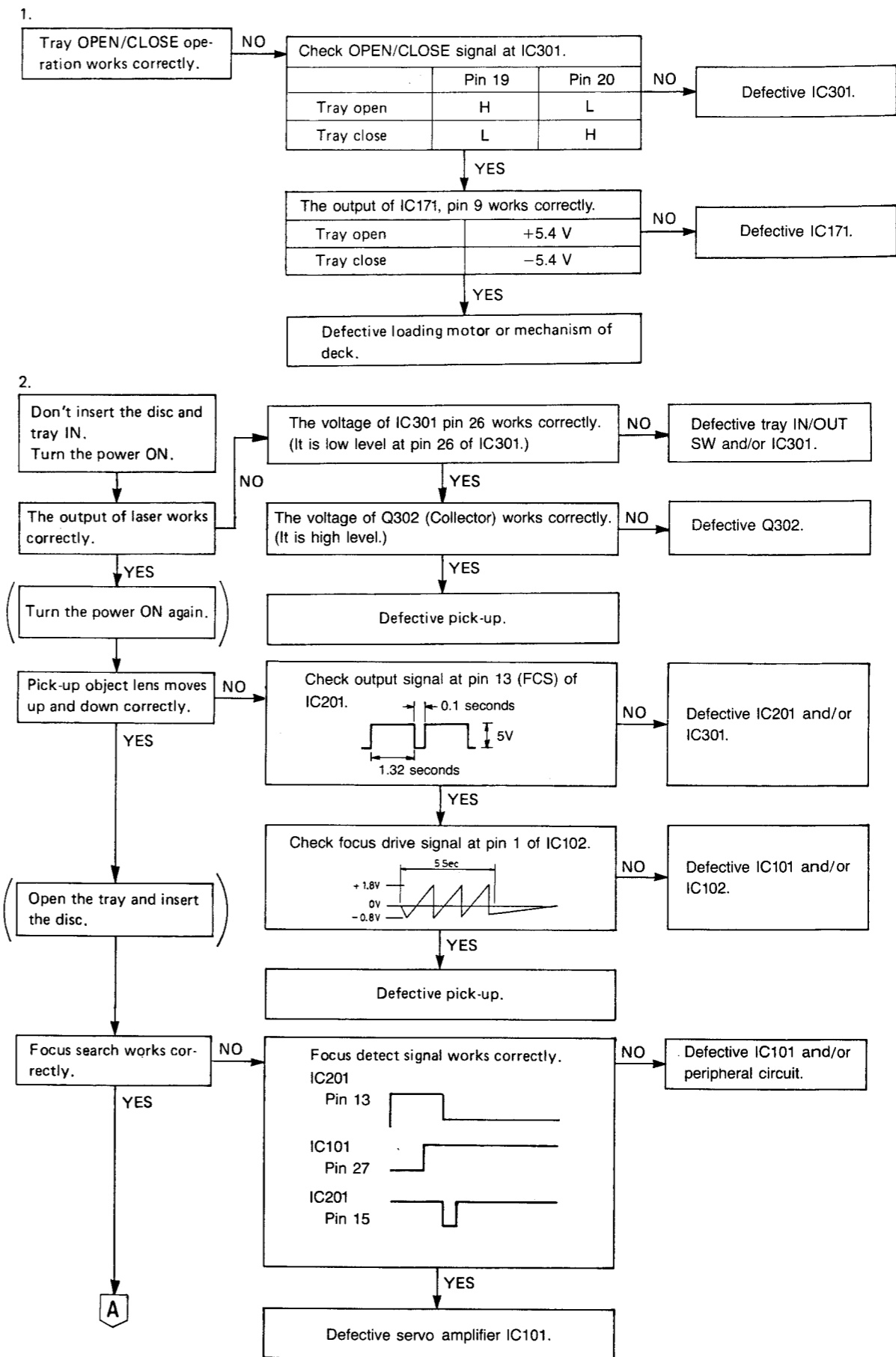

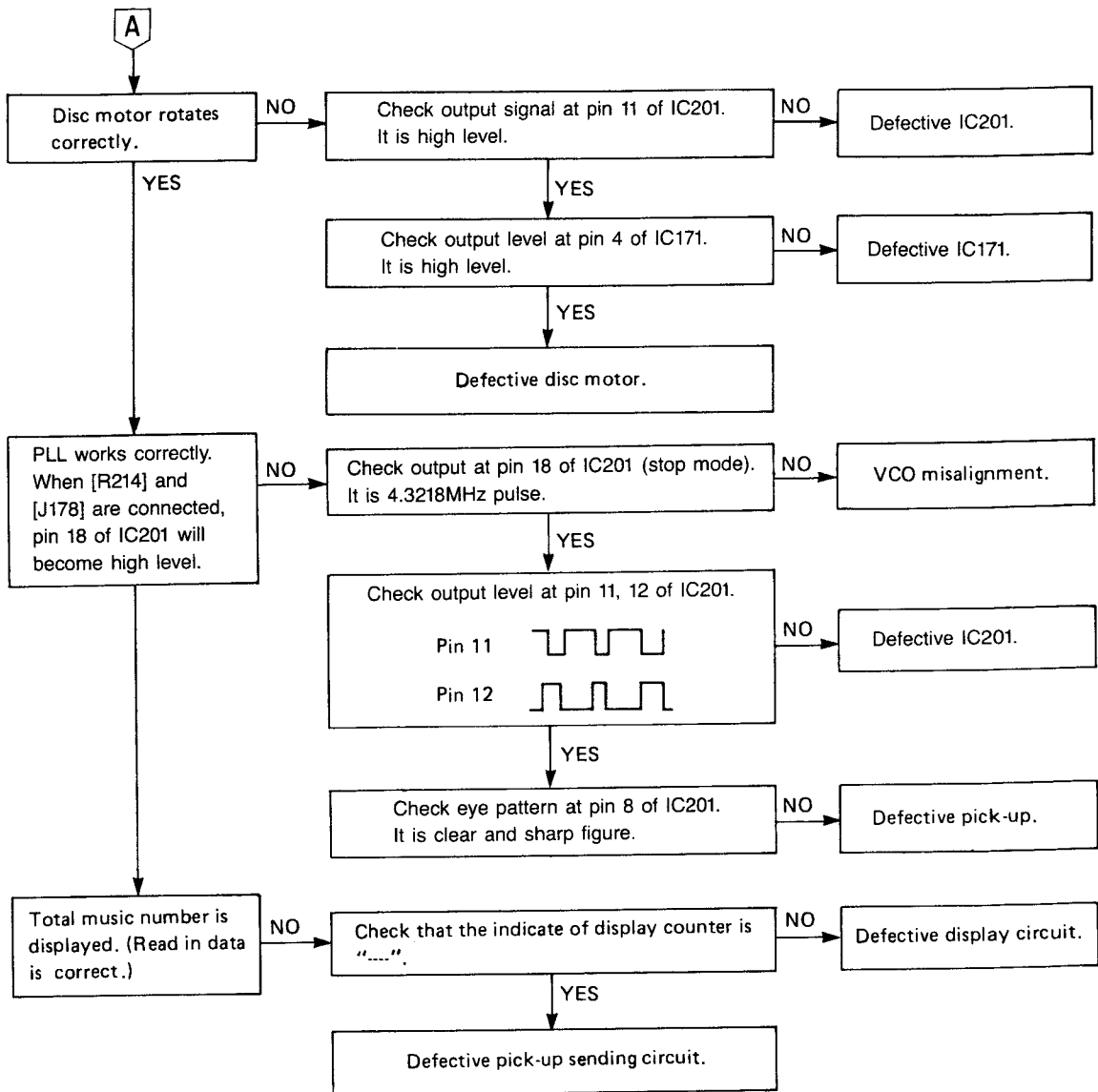

3.

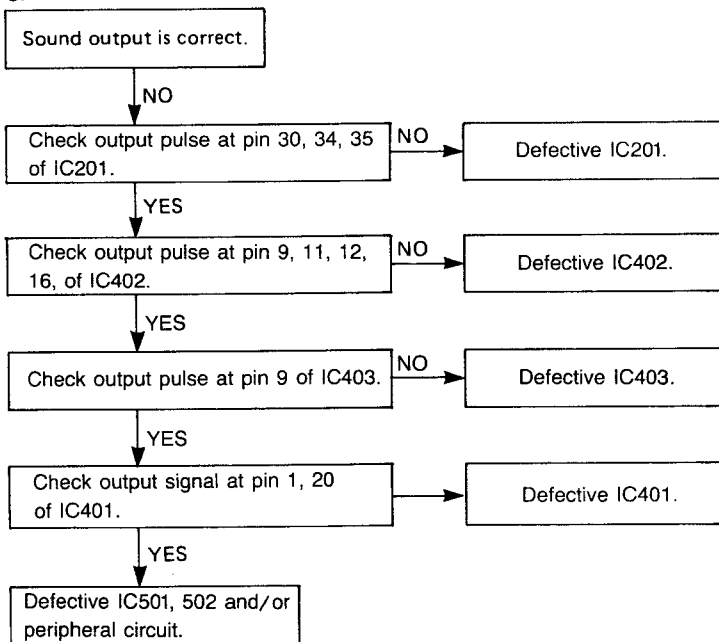

IC DESCRIPTION

LA9200NM IC101 Servo Amp

Block No.	Pin No., Designation	Function
1	46. E0 47. E 48. F 1. F0	I/V Converter
2	2. TEA0	Output of TE Comparator
3	5. TPA+ 6. TPA- 7. TPRO	Phase Correction Circuit
4	8. TOFS 9. THDS 13. THLD 14. TGL 15. TOFF	Tracking Gain Control
5	10. JPO 11. JP- 12. JP+	Kick Pulse Amplifier
6	16. TES 3. TESI	TE Comparator
7	41. FIV1 42. FIV2	I/V Converter
8	36. RFSM 37. RFS-	HF Amplifier
9	35. PHLD	Peak Hold Circuit
10	34. BHLD	Bottom Hold Circuit
11	31. FEA0 32. FEA- 33. FEA+	Focusing Error Amplifier
12	30. FSW 20. FOCS	Focusing Signal Switch
13	26. PD0 28. VCOC 29. VCO-	Filter for P.L.L.
14	22. SLCO 23. EFMO 24. EFMO	Slice Level Control
15	18. FZD	FZD Comparator
16	27. DRF	DRF Comparator
17	38. LDSW 39. LDD	Laser Control
18	17. HFL	HFL Comparator
19	44. VR1 45. VR2 4. VR3	GND
20	40. VCC 43. VEE 21. VCC 19. VEE 25. GND	D.C. Supply

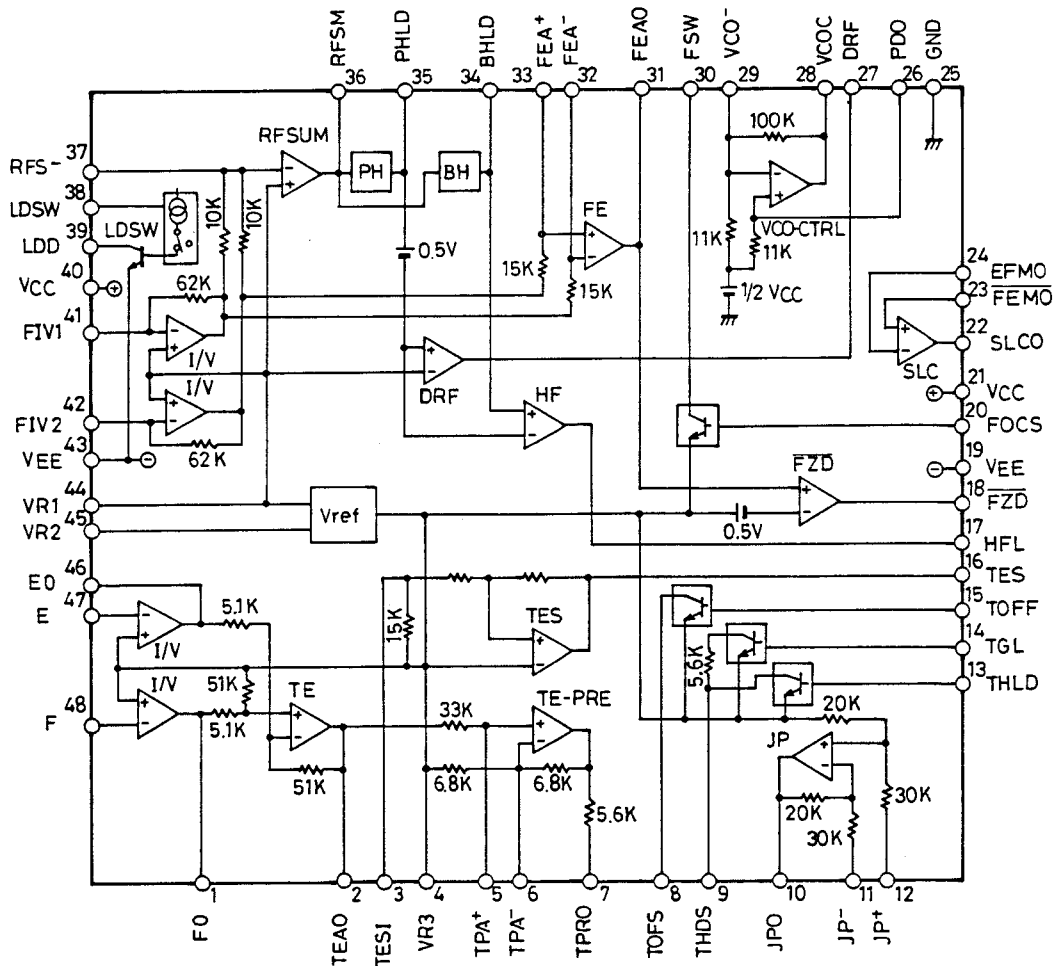

LC7881-B IC401 DAC

Pin No.	Designation	Function
1	CH1 OUT	CH1 Output
2	V ref H1	High-potential side reference power (Input 1)
3	V ref H2	High-potential side reference power (Input 2)
4	V _{DD}	Power Supply (+B)
5	WCLK2	Word Clock input terminal [2]
6	LRCK	L/R Clock
7	WCLK1	Word clock input terminal [1]
8	DATA	Serial input of converted digital signal
9	BCLK	Bit clock to drive shift-resistor and time-generator.
10	V _{DD}	Power Supply (+B)
11	TST OUT	Test pin
12	TST 1	Test pin
13	TST 2	Test pin
14	IF	Change the terminal of interface
15	GND	GND
16	V ref L1	Low-potential side reference power (Input 1)
17	GND	GND
18	V ref L2	Low-potential side reference power (Input 2)
19	NC	No Connection
20	CH2 OUT	CH2 Output

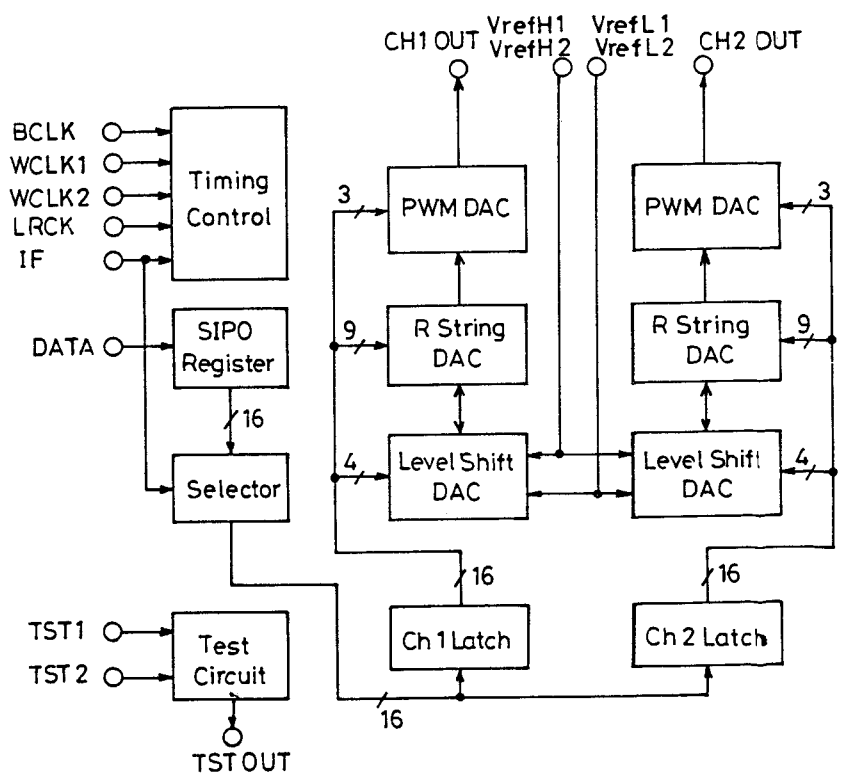
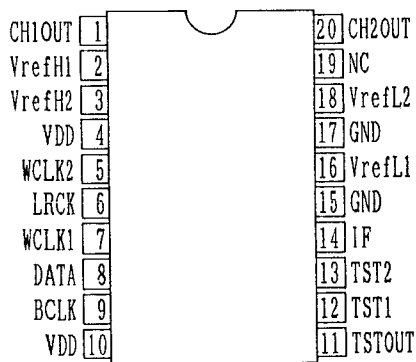

LC7863A IC201 EFM

Block No.	Pin No., Designation	Function
1	79. XIN 80. XOUT	Clock Oscillator
2	6. EFMO 7. EFMO 8. EFMIN	EFM External Circuit
3	2. AO 3. AI 4. PDO	Clock Regeneration Circuit
4	18. FSEQ/PCK	Sync. Match Signal
5	11. CLV+ 12. CLV-	Disc Servo-mechanism related Pins
6	66. PW 67. PWSY 68. SBCK	Sub-code Output
7	70. WRQ 71. RWC 72. SQOUT 75. CQCK 77. M/L	Q-code Output related Pins
8	71. RWC 74. COIN 75. CQCK	μ COM. command related Pins
9	13. FOCS 14. FST 15. FZD	Focus Servo-mechanism related Pins
10	16. HFL 17. TES 19. TOFF 20. TGL 21. THLD 22. JP+ 23. JP-	Tracking Servo-mechanism related Pins
11	24. DEMO	DEMO-Play Input
12	76. RES	Reset Input
13	26. EMPH	De-emphasis Signal
14	65. EFLG 69. FSX	Error Correction Check Signal
15	27. DFOFF 29. SMP2 30. LRCLK 32. SMP3 33. SMP1 34. DFOUT 35. DACLK 38. MSBF	DAC Interface
16	39. CK2 37. LRSY 36. DFIN 28. DSP OFF 64. IOFF	CD-ROM Output
17	41. OE 42. WE 40 to 52. AD0 to AD10 53 to 61. DB0 to DB7	RAM Connection
18	1. TEST1 9. TEST2 25. TEST3 62. TEST4 63. TEST5	Test terminal for LSI

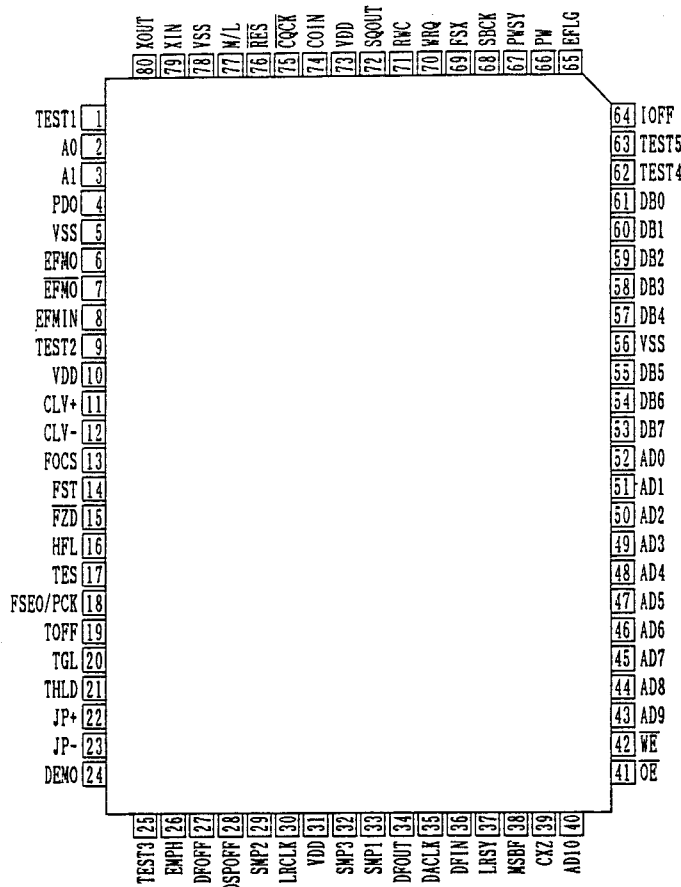

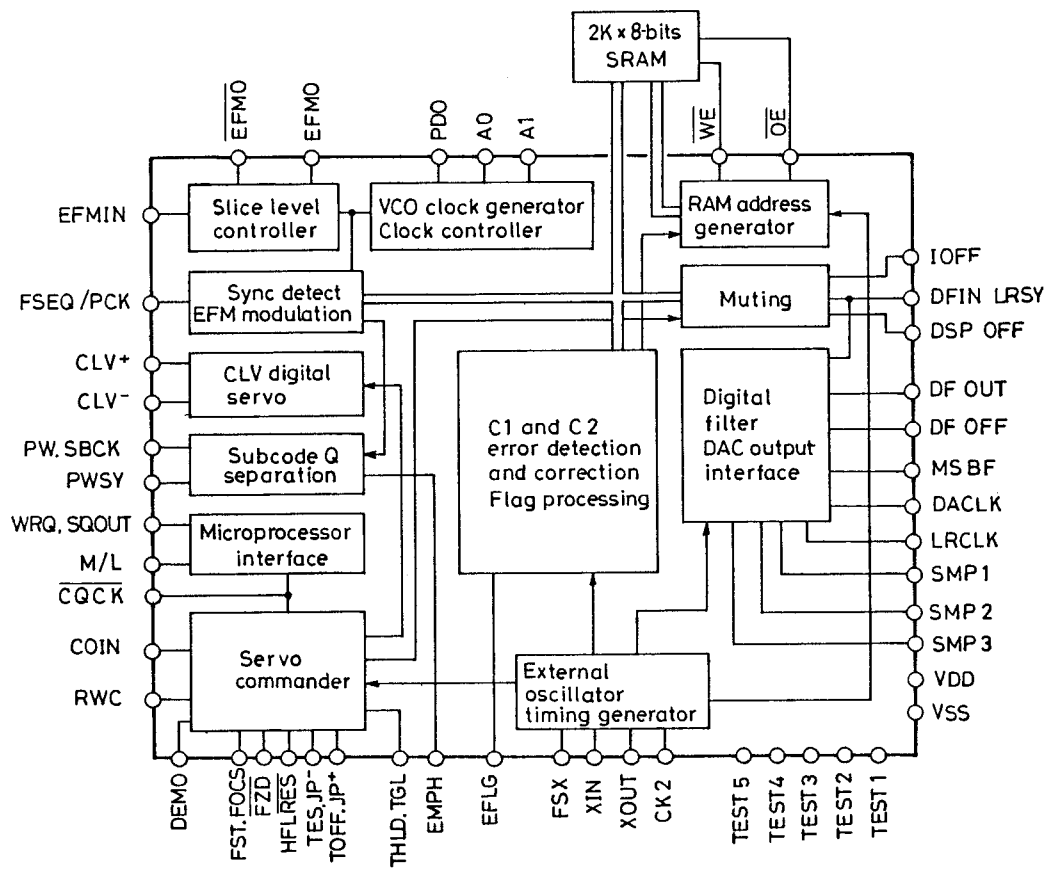

YM3404B IC402 Clock

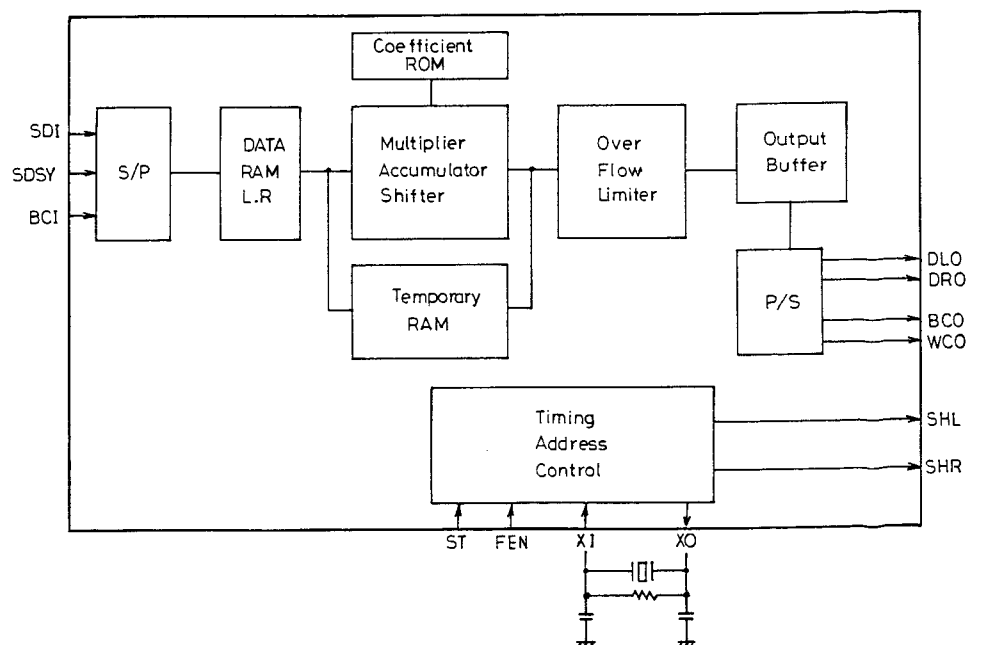
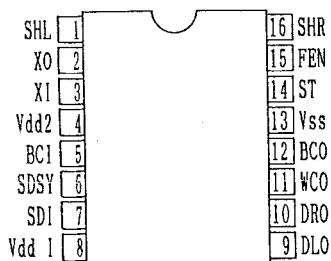

PN0	1	64	VDD
PN1	2	63	PN3
PN2	3	62	PN2
PN3	4	61	PN1
PO0	5	60	PN0
PO1	6	59	PL3
PO2	7	58	PL2
PO3	8	57	PL1
PP0	9	56	PL0
PA0	10	55	PK3
PA1	11	54	PK2
PA2	12	53	PK1
PA3	13	52	PK0
PB0/INT0	14	51	YP
PB1/INT1	15	50	PJ3/CMPB3
PB2/INT2	16	49	PJ2/CMPB2
PB3/INT3	17	48	PJ1/CMPB1
PC0	18	47	PJ0/REFB
PC1	19	46	PI3/CNPA
PC2	20	45	PI2/REFA
PC3	21	44	PI1
PD0	22	43	PI0
PD1	23	42	PG3
PD2	24	41	PG2
PD3	25	40	PG1
PE0	26	39	PG0
PE1	27	38	PH0
PE2	28	37	PF2/SCK
PE3	29	36	PF1/SO
TEST	30	35	PF0/S1
YSS	31	34	RES
OSC1	32	33	OSC2

- RAM : Data memory
- F : Flag
- WR : Working register
- AC : Accumulator
- ALU : Arithmetic and logic unit
- DP : Data pointer
- E : E register
- CTL : Control register
- OSC : Oscillator
- TM : Timer
- STS : Status register
- ROM : Program memory
- PC : Program counter
- INT : Interrupt control
- IR : Instruction register
- I.DEC : Instruction decoder
- CF,CSF : Carry flag, carry save flag
- ZF,ZSF : Zero flag, zero save flag
- EXTF : External interrupt request
- TMF : Internal interrupt request
- INTF : Interrupt request flag
- INTEN : Interrupt enable flag

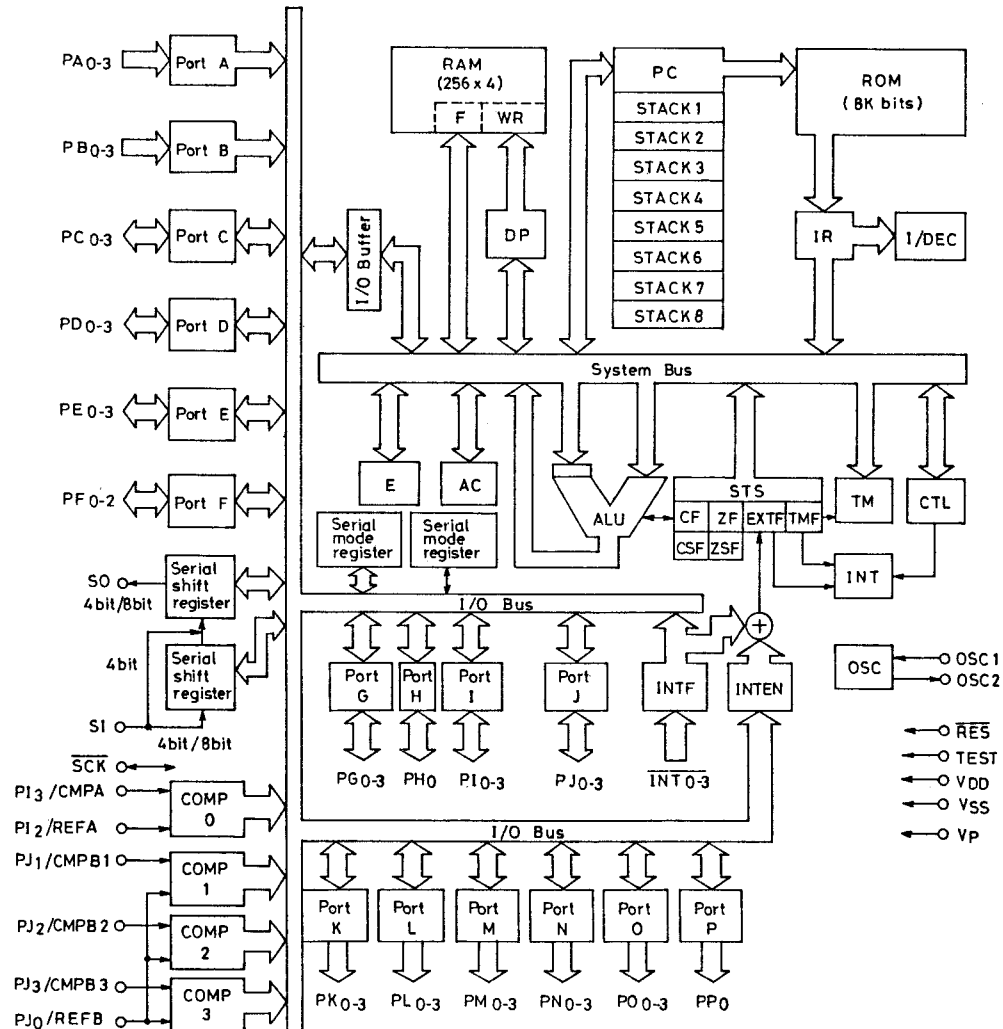

LC3517BS-15 IC202 RAM

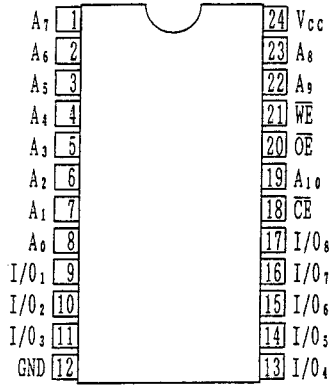

A₀ to A₁₀ : Address input
 WE : Read/write control input
 OE : Output enable input
 CE : Chip enable input
 I/O₁ to I/O₈ : Data input/output
 V_{CC}/GND : Power supply pin

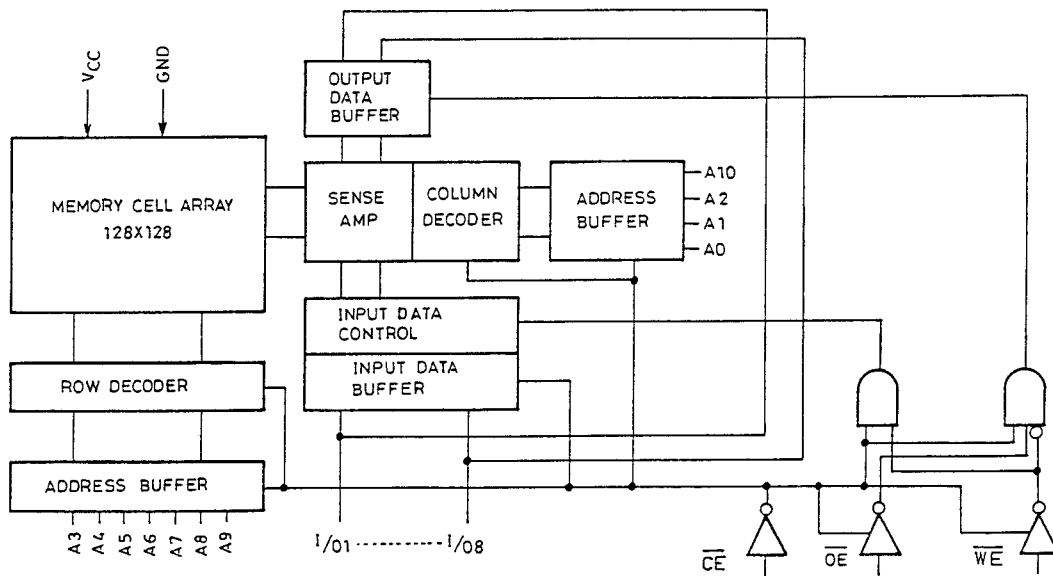

LC6527C-3834 IC351 R/C

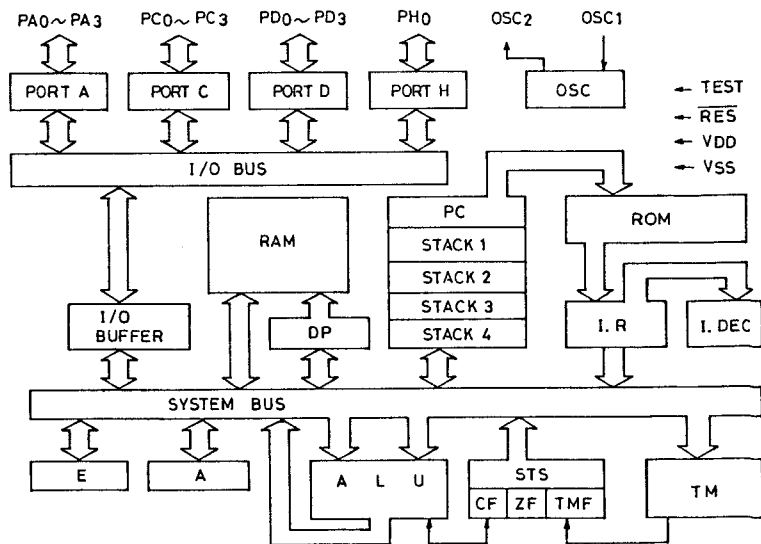
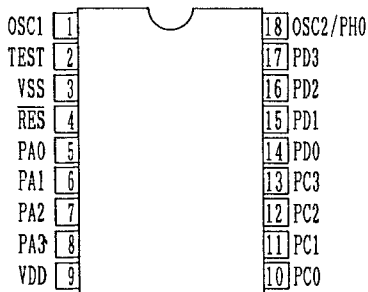

LA6520 IC171 Driver

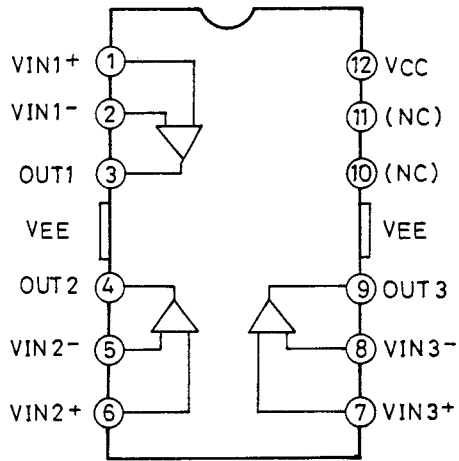

LC74HC74 IC403 F/F

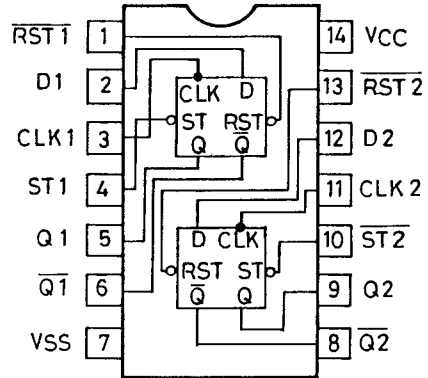

LA6510 IC102 Driver

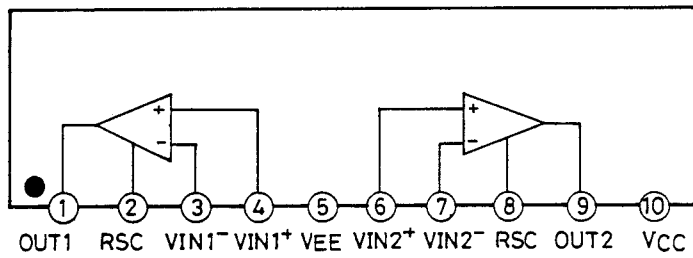

NJM4565SB IC501,502 Amp

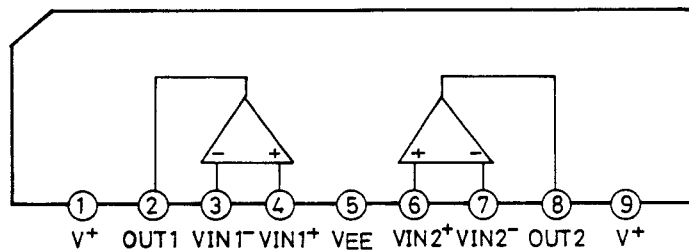

BLOCK DIAGRAM

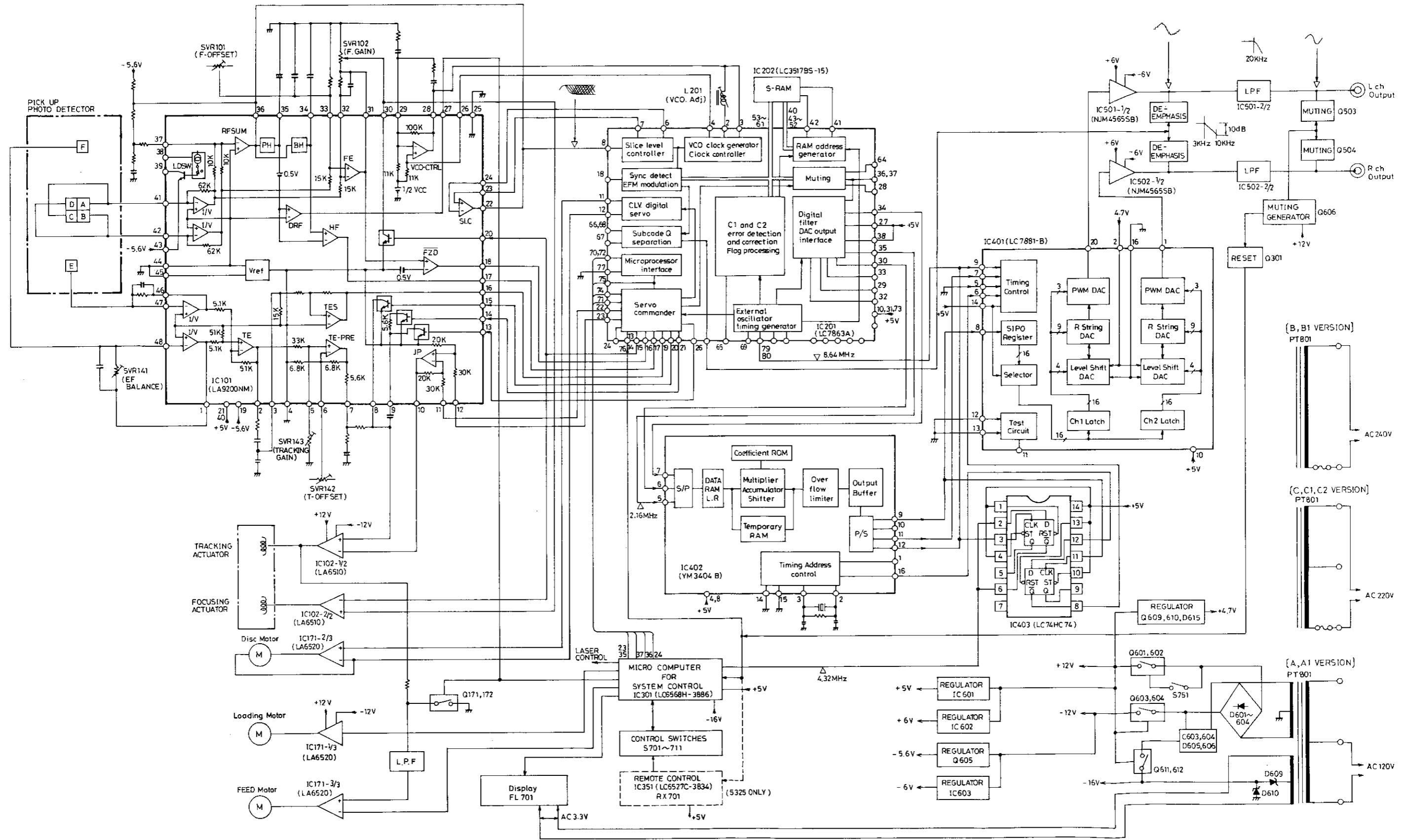

5320 SCHEMATIC, PCB LAYOUT (Foil side)

- NOTES
- All resistors are 1/8 watt 5% unless marked otherwise. Resistor value are in ohms, (K=1000ohms, M=1000Kohms)
 - All capacitor values are in microfarads (P=picofarads)
 - ⚠ is Safety parts. Use only replacement parts recommended by the manufacturer. Each DC voltage shows the nominal values in volts no input signal.
- CAUTION
Before returning the unit to the customer, make sure you make either (1) a leakage current check or (2) a line to chassis resistance check. If the leakage current exceeds 0.5 milliamperes or if the resistance from chassis to either side of the power cord is less than 500k ohms, the unit is defective.
- WARNING- DO NOT return the unit to the customer until the problem is located and corrected.

--- Digital Signal
--- Analog Signal

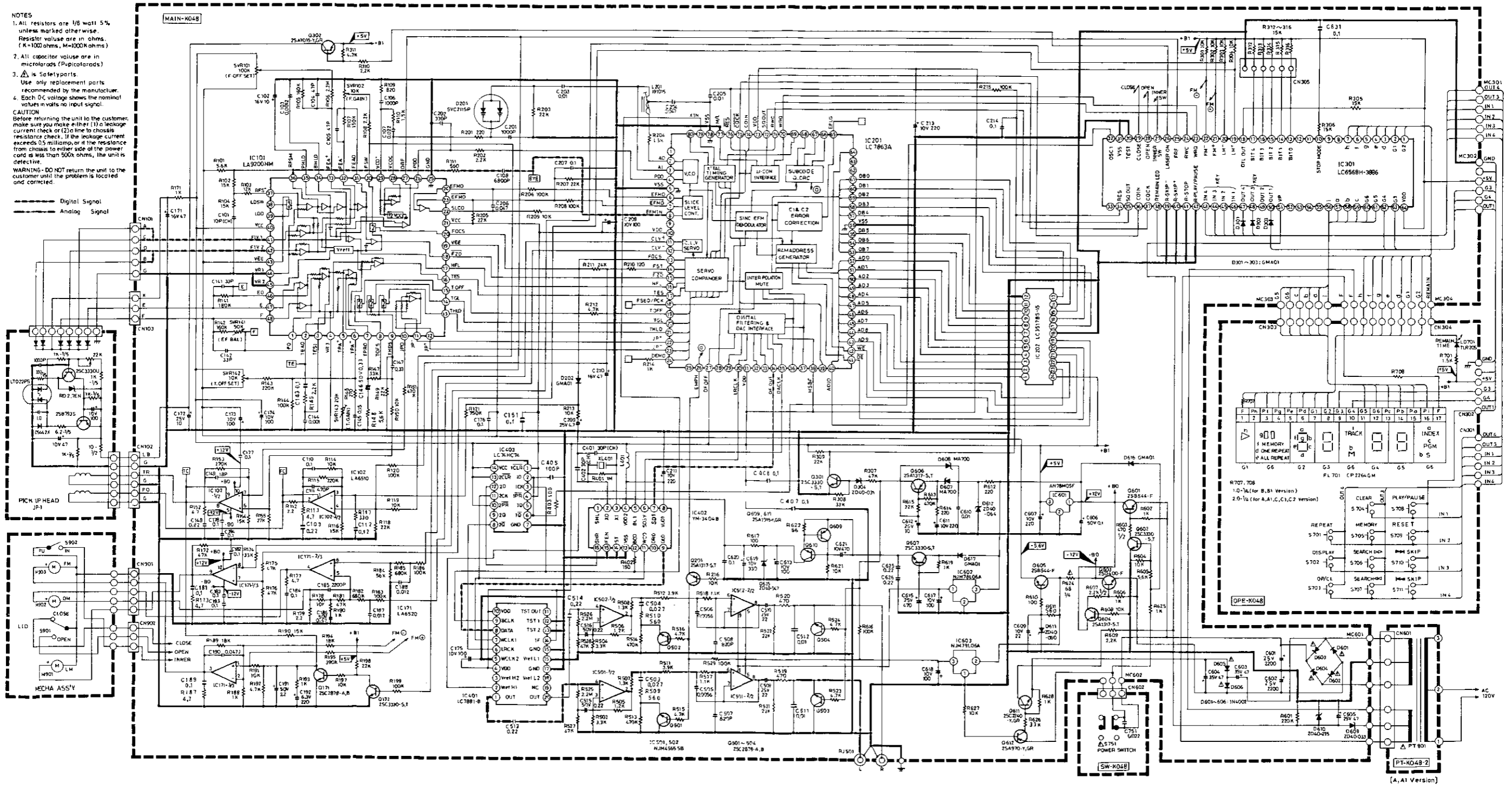

5325 SCHEMATIC, PCB LAYOUT (Foil side)

- NOTES
1. All resistors are 1/8 watt 5% unless marked otherwise. Resistor values are in ohms, (K=1000ohms, M=1000Kohms)
 2. All capacitor values are in microfarads (P=picofarads)
 3. Δ is Safety parts. Use only replacement parts recommended by the manufacturer.
 4. Each DC voltage shows the nominal values in volts no input signal.
- CAUTION
Before returning the unit to the customer, make sure you make either (1) a leakage current check or (2) a line to chassis resistance check. If the leakage current exceeds 0.5 milliamps, or if the resistance from chassis to either side of the power cord is less than 500K ohms, the unit is defective.
- WARNING: DO NOT return the customer until the problem is located and corrected.

--- Digital Signal
--- Analog Signal

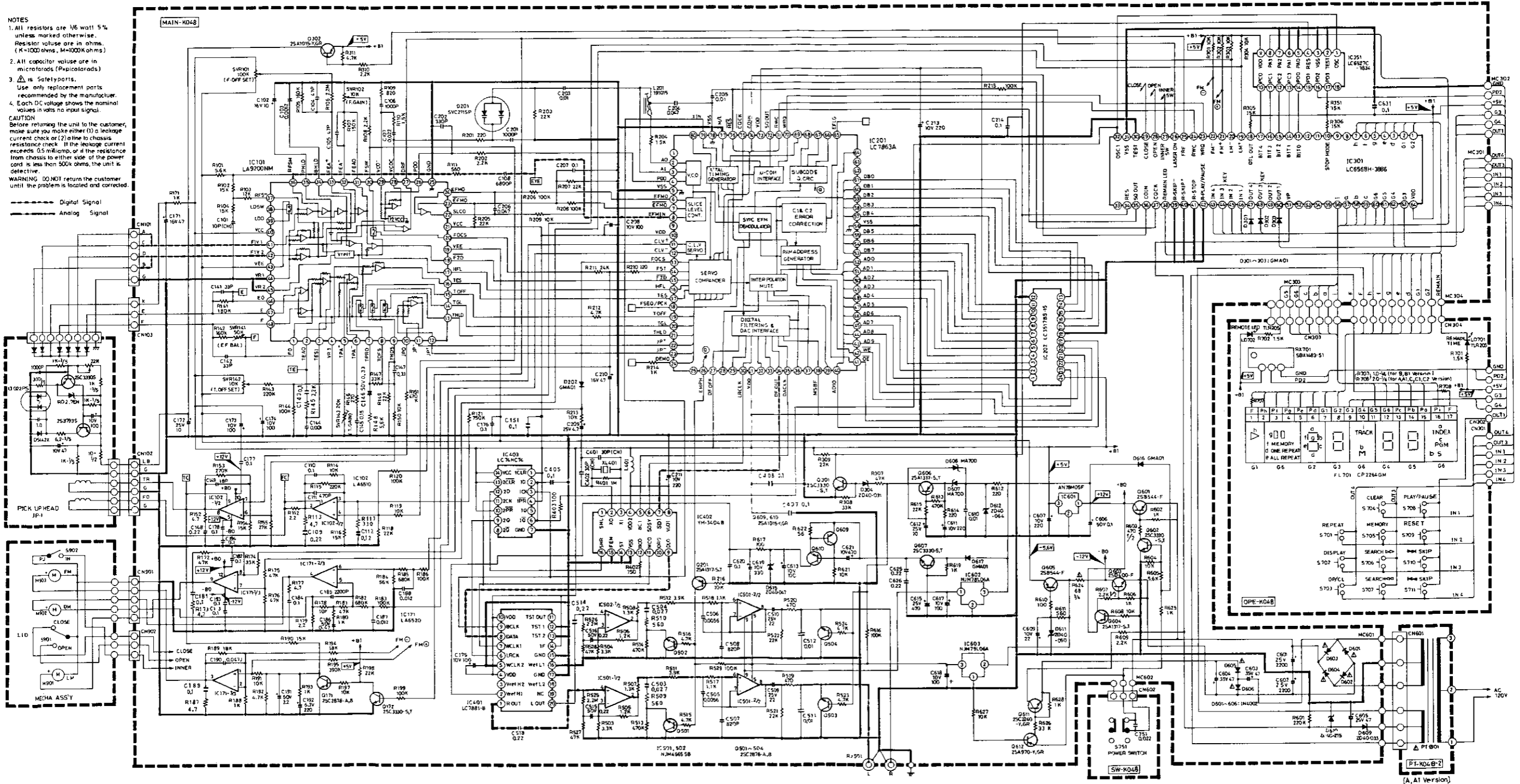

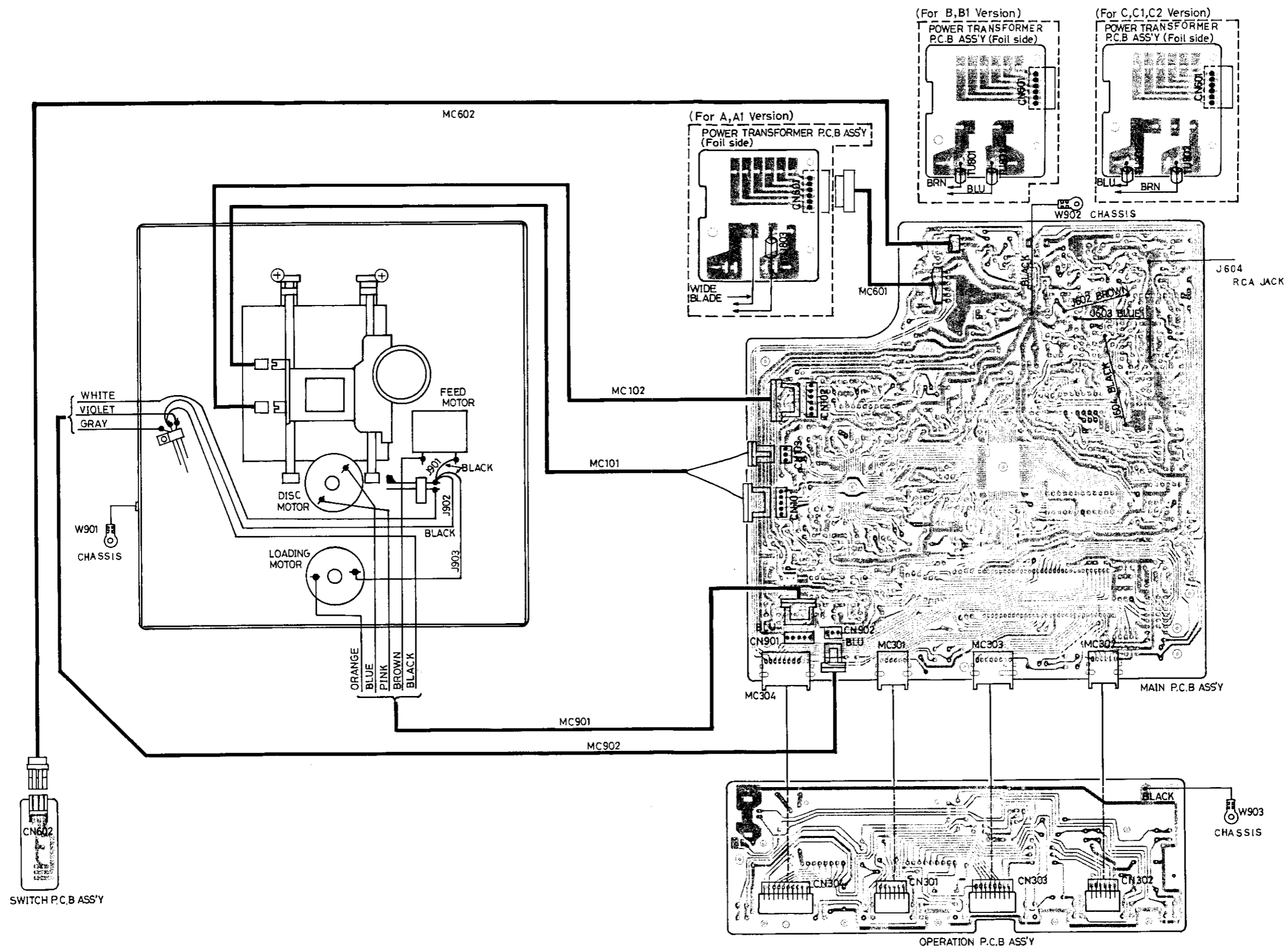

PWR TRANS, PWR SW PCB LAYOUT (Foil side)

Power Transformer (PT) 5320/5325

A, A1 version

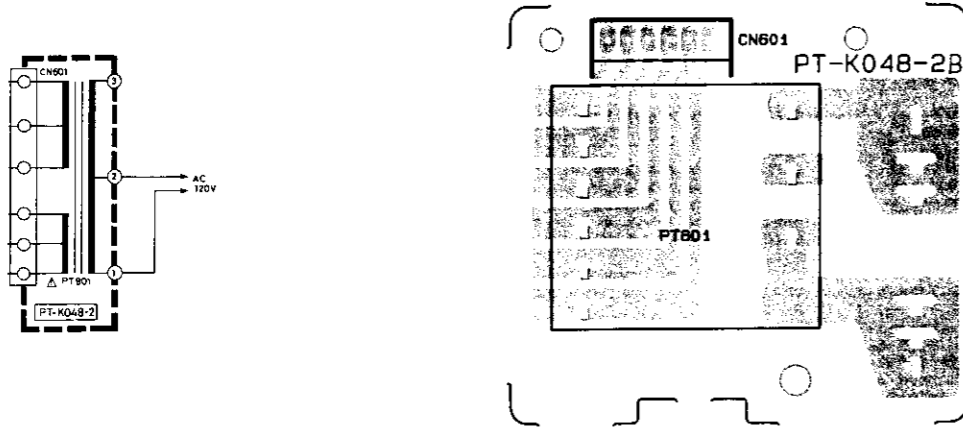

B, B1 version

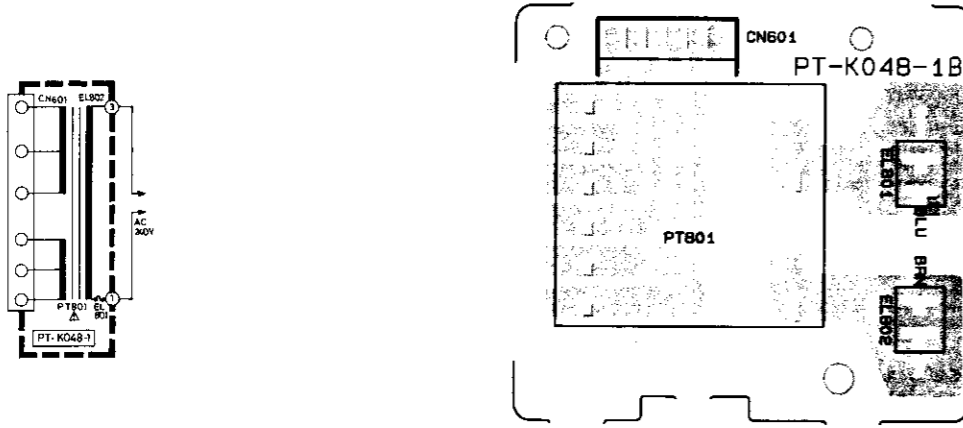

C, C1, C2 version

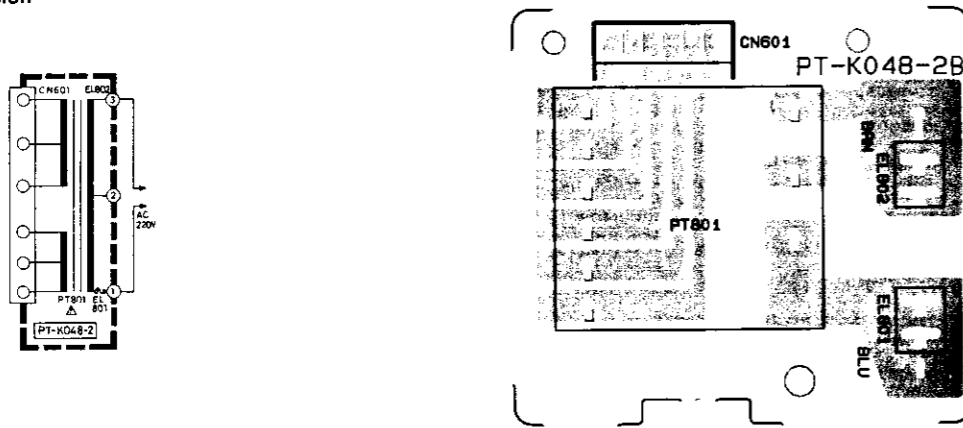

Power Switch (SW) 5320/5325 all version

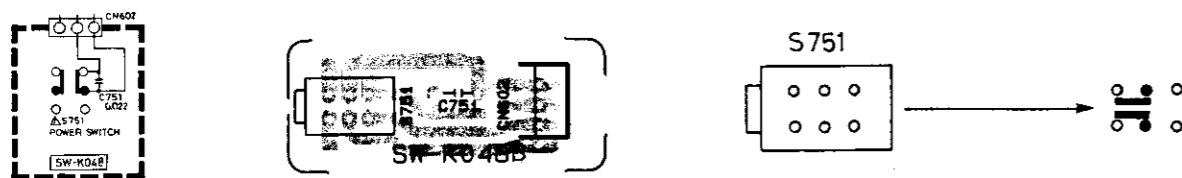

MECHANISM EXPLODED VIEW AND PARTS LIST

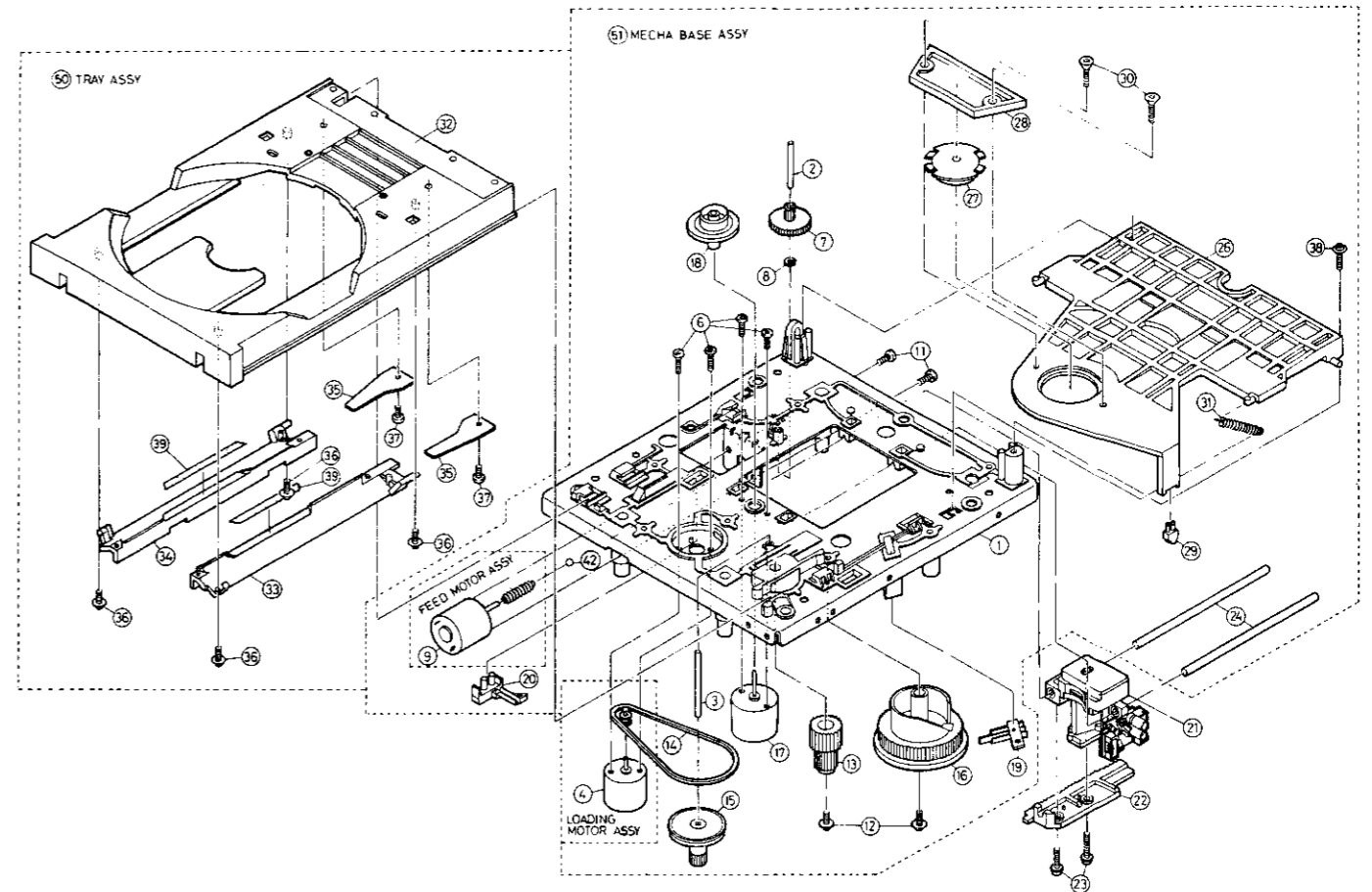

REF. NO.	Q'TY	PART NO.	DESCRIPTION
001	1	7910635	BASE MECHANISM
002	1	7910637	PIN HEAD-FEED
003	1	7910638	PIN LOADING
004	1	7900181	LOADING MOTOR ASSY
006	4	7910659	SCREW M2L=4W/SPRING WASHER
007	1	7910642	WORM GEAR W/PINION
008	1	7910643	WASHER
009	1	7900192	FEED MOTOR ASSY
011	2	7900233	SCREW M2L=5W/SPRING WASHER
012	2	7910657	TAPPING SCREW WHL=8
013	1	7910650	FINAL GEAR
014	1	7910651	BELT RUBBER
015	1	7910648	PULLEY B
016	1	7910649	GEAR MAIN
017	1	7900074	MOTOR DISC
018	1	7910639	TURN TABLE
019	1	7910661	LEAF SWITCH 2 POLES
020	1	7900313	LEAF SWITCH MONO POLE
021	1	JP-1	PICK UP HEAD
022	1	7900197	SEND HACK+C

REF. NO.	Q'TY	PART NO.	DESCRIPTION
023	2	7910731	SCREW M2.6L=8W/SPRING WASHER
024	2	7910644	FEEDING SHAFT
026	1	7910627	CLAMPER ARM
027	1	7910628	CLAMPER DISC
028	1	7900127	FIXING PLATE
029	1	7900093	BUSHING CLAMP ARM
030	2	7900130	SCREW TAPPING
031	1	7910630	SPRING TENSION
032	1	7910631	TRAY DISC
033	1	7900166	TRAY SUB LEFT
034	1	7900167	TRAY SUB RIGHT
035	2	7900168	SPRING SUB TRAY
036	4	7900335	TAPPING SCREW L=4
037	2	7900005	TAPPING SCREW
038	1	7900214	TAPPING SCREW WHL=8
039	2	N45346	DISC CUSHION
042	1	7900232	STEEL BALL
050	1	7900175	TRAY ASSY
051	1	7910647	MECHA BASE ASSY

DIFFERENT PARTS LIST

A : USA B : U.K. C : EUROPE & OTHERS C2 : G.P.M
A1 : CANADA B1 : AUSTRALIA/N.Z. C1 : W.GERMANY

* : vary according to destinations.

Ref.No.	Description	A	A1	B	B1	C/C1	C2
EXPLODED VIEW							
2M 5	LASER LABEL	N45502	←	Nil	←	←	←
2M 7	POLYETHYLENE BAG (UNIT)	N41886-2	←	N41886H-2	N41886-2	←	←
2M17	CARD, WARRANTY REGISTRATION	NAD-WC2A	←	Nil	←	←	←
2M23	CARD	Nil	←	LEN-200	←	←	←
2M23-1	LABEL (LASER, MARK)	Nil	←	N44838	←	←	←
2M24	CARD, WARRANTY	Nil	←	LEN-201	←	←	←
2M24-1	LABEL (LASER, CAUTION)	Nil	←	N44839	←	←	←
2M25	LABEL (CLASS 1 LASER PRODUCT)	Nil	←	N44837	←	←	←
2M26	TAG (AC CORD)	Nil	←	N41117	Nil	←	←
2M27	SAFETY INSTRUCTION SHEET	BK3035	←	Nil	←	←	←
2M27-1	STICKER WARNING	Nil	←	N41994	Nil	←	←
2M28	SHEET, PORTABLE CART WARNING	N45475	←	←	←	←	←
15E 1	LINE CORD	ACC-033E5-4EE1	←	ACC-013D3-4EC4	ACC-030D3-4EC1	ACC-005E3-4EE1	←
15E 3	CORD STOPPER	SR-4N-4	←	SR-5N-4	SR-4N-4	←	←
P903	CONVERSION PLUG	Nil	←	←	←	←	S-16115#01
OPERATION PCB ASS'Y							
R707,708	CARBON RESISTOR	KA25ST2R0J	←	KA25ST1R0J	←	KA25ST2R0J	←
POWER TRANSFORMER PCB ASS'Y							
14E13	PRINTED CIRCUIT BOARD	PT-K048-2B	←	PT-K048-1B	←	PT-K048-2B	←
EL801,802	TERMINAL	Nil	←	TER61-0171	←	←	←
PT801	POWER TRANSFORMER	NPT-K0164	←	NPT-K0166	←	NPT-K0165	←
OTHER PARTS							
TU801,802	UL TYPE TUBE	Nil	←	U9-#03B015	←	←	←
TU803	UL TYPE TUBE	U9-#03B01	←	Nil	←	←	←

** : vary according to models.

Ref.No.	Description	5325	5320	Ref.No.	Description	5325	5320
EXPLODED VIEW							
1M 3	TRAY PANEL	BK3023-4	BK3023-3	CN305	CONNECTOR	Nil	EMCS0660MT6
1M 6	DISPLAY GLASS	N45485-2	N45485-1	IC351	IC	LC6527C-3834	Nil
2M14	INNER CARTON	N21710-2	N21710-1	J170	JUMP WIRE	E125	Nil
15E11	REMOTE CONTROL TRANSMITTER	RC5325	Nil	J171	JUMP WIRE	E200	Nil
15E12	BATTERY	UM-4-2	Nil	J161	JUMP WIRE	E100	Nil
OPERATION PCB ASS'Y							
CN303	PCB PLUG	TKC-B08P-E1	TKC-B06P-E1	J182	JUMP WIRE	Nil	E075
J717	JUMP WIRE	E100	Nil	J183-185	JUMP WIRE	E100	Nil
LD702	LED	TLR205	Nil	J187	JUMP WIRE	E175	Nil
R702	CARBON RESISTOR	KA163T152J	Nil	J188	JUMP WIRE	E050	Nil
RX701	REMOTE SIGNAL RECEIVING UNIT	SUX1483-51	Nil	MC303	PCB SOCKET	TKC-B08X-E1	TKC-B06X-E1
				R312-316	CARBON RESISTOR	Nil	KA165T153J
				R351	CARBON RESISTOR	KA165T153J	Nil

*** : vary according to models and destinations.

Ref.No.	Description	A	A1	B	B1	C/C1	C2
EXPLODED VIEW							
5325	REAR LABEL	N45463-9	←	N45463-12	←	N45463-13	←
2M21	REAR LABEL	N45463-8	←	N45463-10	←	N45463-11	←

ELECTRICAL PARTS LIST

MAIN PCB ASSY

REF. NO.	Q'TY	PART NO.	DESCRIPTION
P.C. BOARD			
IE 1	1	MAIN-K048B	PRINTED CIRCUIT BOARD
SEMICONDUCTORS			
0201	1	SVC2115P-B,C	DIODE
0202,301-303	4	GMA01	DIODE
0304	1	Z040-031	ZENER DIODE,2/5W,3.1V
0601-606	6	1N4002	DIODE
0607,608	2	MA700	DIODE
0609	1	Z040-033	ZENER DIODE,2/5W,3.3V
0610	1	Z040-215	ZENER DIODE,2/5W,21.5V
0611	1	Z040-060	ZENER DIODE,2/5W,6.0V
0612	1	Z040-064	ZENER DIODE,2/5W,6.4V
0615	1	Z040-047	ZENER DIODE,2/5W,4.7V
0616,617	2	GMA01	DIODE
0171	1	2SC2878-A,B	TRANSISTOR
0172	1	2SC3330-S,T	TRANSISTOR
0201	1	2SA1317-S,T	TRANSISTOR
0301	1	2SC3330-S,T	TRANSISTOR
0302	1	2SA1015-Y,GR	TRANSISTOR
0501-504	4	2SC2878-A,B	TRANSISTOR
0601	1	2SB544-F	TRANSISTOR
0602	1	2SC3330-S,T	TRANSISTOR
0603	1	2SD400-F	TRANSISTOR
0604	1	2SA1317-S,T	TRANSISTOR
0605	1	2SB544-F	TRANSISTOR
0606	1	2SA1317-S,T	TRANSISTOR
0607	1	2SC3330-S,T	TRANSISTOR
0609,610	2	2SA1015-Y,GR	TRANSISTOR
0611	1	2SC2240-Y,GR	TRANSISTOR
0612	1	2SA970-Y,GR	TRANSISTOR
IC101	1	LA9200NM	IC
IC102	1	LA6510	IC
IC171	1	LA6520	IC
IC201	1	LC7863A	IC
IC202	1	LC3517BS-15	IC
IC301	1	LC6569H-3886	IC
** IC351	1	LC6527C-3834	IC
IC401	1	LC7881-B	IC
IC402	1	YM3404B	IC
IC403	1	LC74HC74	IC
IC501,502	2	NJM4565SB	IC
IC601	1	AN78M05F	IC
IC602	1	NJM78L06A	IC
IC603	1	NJM79L06A	IC
CAPACITORS			
C101	1	HE405JCH1000	CERAMIC CAPACITOR
C102	1	NS-16TW100M	ELECTROLYTIC CAPACITOR
C103	1	MY-50VS122J	MYLAR CAPACITOR
C104,105	2	HE405JSL470K	CERAMIC CAPACITOR
C106	1	MY-50VS102J	MYLAR CAPACITOR
C107	1	MY-50VS222J	MYLAR CAPACITOR
C108	1	MY-50VS682J	MYLAR CAPACITOR
C109	1	XB105JYF224Z	IBL. CERAMIC CAPACITOR
C110	1	MY-50VU104J	MYLAR CAPACITOR
C111	1	HE405JYB471K	CERAMIC CAPACITOR
C112	1	MY-50VU124J	MYLAR CAPACITOR
C141,142	2	HE405JSL330J	CERAMIC CAPACITOR
C143	1	MY-50VU104J	MYLAR CAPACITOR
C144	1	MY-50VS102J	MYLAR CAPACITOR
C145	1	MY-50VU154J	MYLAR CAPACITOR
C146	1	NP-50TWR33M	ELECTROLYTIC CAPACITOR
C147	1	S05MC334J	METALLIZED FILM CAPACITOR
C148	1	XB105JYF224Z	IBL. CERAMIC CAPACITOR
C149	1	HE405JSL180K	CERAMIC CAPACITOR
C151	1	XB655JYF104Z	IBL. CERAMIC CAPACITOR
C171	1	NS-16TW470M	ELECTROLYTIC CAPACITOR
C172	1	NS-25TW100M	ELECTROLYTIC CAPACITOR
C175-175	3	NS-10TW101M	ELECTROLYTIC CAPACITOR
C176-178,181-184	7	XB655JYF104Z	IBL. CERAMIC CAPACITOR
C185	1	MY-50VS222J	MYLAR CAPACITOR
C186	1	ES-50TWR47M	ELECTROLYTIC CAPACITOR
C187,188	2	MY-50VS125J	MYLAR CAPACITOR
C189	1	XB655JYF104Z	IBL. CERAMIC CAPACITOR
C190	1	MY-50VS473J	MYLAR CAPACITOR
C191	1	NS-50TWR22M	ELECTROLYTIC CAPACITOR
C192	1	NS6R3TW221M	ELECTROLYTIC CAPACITOR
C193,194	2	XB655JYF104Z	IBL. CERAMIC CAPACITOR
C201	1	MY-50VS102J	MYLAR CAPACITOR
C202	1	ECQP-1331JZ	POLYESTER FILM CAPACITOR
C203	1	MY-50VS103J	MYLAR CAPACITOR
C204	1	MY-50VS473J	MYLAR CAPACITOR
C205	1	MY-50VS103K	MYLAR CAPACITOR
C206	1	MY-50VS473J	MYLAR CAPACITOR
C207	1	MY-50VU104J	MYLAR CAPACITOR
C208	1	NS-10TW101M	ELECTROLYTIC CAPACITOR
C209	1	NS-25TW47M	ELECTROLYTIC CAPACITOR
C210	1	NS-16TW470M	ELECTROLYTIC CAPACITOR
C211,213	2	NS-10TW221M	ELECTROLYTIC CAPACITOR
C214	1	XB655JYF104Z	IBL. CERAMIC CAPACITOR
C401,402	2	HE505JCH300J	CERAMIC CAPACITOR
C405	1	HE505JSL101J	CERAMIC CAPACITOR
C407,408	2	XB655JYF104Z	IBL. CERAMIC CAPACITOR

• Parts marked with * vary according to destinations.
• Parts marked with ** vary according to models.
• Parts marked with *** vary according to models and destinations.
For details, refer to the different parts list.

REF. NO.	Q'TY	PART NO.	DESCRIPTION
C503,504	2	MYPP2A273J	POLYESTER FILM CAPACITOR
C505,506	2	MYPP2A562J	POLYESTER FILM CAPACITOR
C507,508	2	MYPP2A821J	POLYESTER FILM CAPACITOR
C509,510	2	NP-25TW220M	ELECTROLYTIC CAPACITOR
C511,512	2	MYPP2A103J	POLYESTER FILM CAPACITOR
C513,514	2	MY-50VU224J	MYLAR CAPACITOR
C515,516	2	NP-50TWR22M	ELECTROLYTIC CAPACITOR
C601,602	2	NS-25TW222M-KF	ELECTROLYTIC CAPACITOR
C603,604	2	NS-35TW470M	ELECTROLYTIC CAPACITOR
C605	1	NS-25TW470M	ELECTROLYTIC CAPACITOR
C606	1	NS-50TWR10M	ELECTROLYTIC CAPACITOR
C607	1	NS-10TW221M	ELECTROLYTIC CAPACITOR
C609	1	NS-10TW220M	ELECTROLYTIC CAPACITOR
C610	1	HE705JYF103Z	CERAMIC CAPACITOR
C611	1	NS-10TW221M	ELECTROLYTIC CAPACITOR
C612	1	NS-25TW100M	ELECTROLYTIC CAPACITOR
C613	1	NS-10TW101M	ELECTROLYTIC CAPACITOR
C615	1	NS-25TW471M-KF	ELECTROLYTIC CAPACITOR
C617,618	2	NS-10TW101M	ELECTROLYTIC CAPACITOR
C619	1	NS-10TW331M	ELECTROLYTIC CAPACITOR
C620	1	XB655JYF104Z	IBL. CERAMIC CAPACITOR
C621	1	NS-10TW471M	ELECTROLYTIC CAPACITOR
C625,626	2	KD105JYF224Z	IBL. CERAMIC CAPACITOR
C631	1	XB655JYF104Z	IBL. CERAMIC CAPACITOR
RESISTORS			
R101	1	KA165T562J	CARBON RESISTOR
R102	1	KA165T153J	CARBON RESISTOR
R103	1	KA165T123J	CARBON RESISTOR
R104	1	KA165T153J	CARBON RESISTOR
R105	1	KA165T164J	CARBON RESISTOR
R106	1	KA165T225J	CARBON RESISTOR
R107	1	KA165T154J	CARBON RESISTOR
R108	1	KA165T222J	CARBON RESISTOR
R109	1	KA165T621J	CARBON RESISTOR
R110	1	KA165T152J	CARBON RESISTOR
R111	1	KA165T561J	CARBON RESISTOR
R112	1	KA165T2R2J	CARBON RESISTOR
R113	1	KA165T4R7J	CARBON RESISTOR
R114	1	KA165T103J	CARBON RESISTOR
R115	1	KA165T224J	CARBON RESISTOR
R116	1	KA165T153J	CARBON RESISTOR
R117	1	KA165T331J	CARBON RESISTOR
R118	1	KA165T223J	CARBON RESISTOR
R119	1	KA165T103J	CARBON RESISTOR
R120	1	KA165T104J	CARBON RESISTOR
R121	1	KA165T754J	CARBON RESISTOR
R141	1	KA165T184J	CARBON RESISTOR
R142	1	KA165T164J	CARBON RESISTOR
R143	1	KA165T224J	CARBON RESISTOR
R144	1	KA165T104J	CARBON RESISTOR
R145	1	KA165T222J	CARBON RESISTOR
R146	1	KA165T271J	CARBON RESISTOR
R147	1	KA165T333J	CARBON RESISTOR
R148	1	KA165T562J	CARBON RESISTOR
R149	1	KA165T223J	CARBON RESISTOR
R150	1	KA165T103J	CARBON RESISTOR
R151	1	KA165T474J	CARBON RESISTOR
R152	1	KA165T4R7J	CARBON RESISTOR
R153	1	KA165T274J	CARBON RESISTOR
R154	1	KA165T153J	CARBON RESISTOR
R155	1	KA165T273J	CARBON RESISTOR
R171	1	KA165T102J	CARBON RESISTOR
R172	1	KA165T473J	CARBON RESISTOR
R173	1	KA165T4R7J	CARBON RESISTOR
R174	1	KA165T333J	CARBON RESISTOR
R175,176	2	KA165T473J	CARBON RESISTOR
R177	1	KA165T4R7J	CARBON RESISTOR
R178	1	KA165T103J	CARBON RESISTOR
R179	1	KA165T2R2J	CARBON RESISTOR
R180	1	KA165T102J	CARBON RESISTOR
R181	1	KA165T473J	CARBON RESISTOR
R182	1	KA165T684J	CARBON RESISTOR
R183	1	KA165T104J	CARBON RESISTOR
R184	1	KA165T563J	CARBON RESISTOR
R185	1	KA165T684J	CARBON RESISTOR
R186	1	KA165T104J	CARBON

REF. NU.	Q'TY	PART NO.	DESCRIPTION
R210	1	KA16ST121J	CARBON RESISTOR
R211	1	KA16ST243J	CARBON RESISTOR
R212	1	KA16ST472J	CARBON RESISTOR
R213	1	KA16ST103J	CARBON RESISTOR
R214	1	KA16ST102J	CARBON RESISTOR
R215	1	KA16ST104J	CARBON RESISTOR
R216,301~304	5	KA16ST103J	CARBON RESISTOR
R305,306	2	KA16ST153J	CARBON RESISTOR
R307	1	KA16ST473J	CARBON RESISTOR
R308	1	KA16ST333J	CARBON RESISTOR
R309	1	KA16ST223J	CARBON RESISTOR
R310	1	KA16ST222J	CARBON RESISTOR
R311	1	KA16ST472J	CARBON RESISTOR
**R351	1	KA16ST153J	CARBON RESISTOR
R401	1	KA16ST105J	CARBON RESISTOR
R402	1	KA16ST151J	CARBON RESISTOR
R403	1	KA16ST101J	CARBON RESISTOR
R503,504	2	KA16ST332J	CARBON RESISTOR
R505,506	2	KA16ST122J	CARBON RESISTOR
R507,508	2	KA16ST132J	CARBON RESISTOR
R509,510	2	KA16ST561J	CARBON RESISTOR
R511,512	2	KA16ST392J	CARBON RESISTOR
R513,514	2	KA16ST474J	CARBON RESISTOR
R515,516	2	KA16ST472J	CARBON RESISTOR
R517,518	2	KA16ST112J	CARBON RESISTOR
R519,520	2	KA16ST471J	CARBON RESISTOR
R521,522	2	KA16ST223J	CARBON RESISTOR
R523,524	2	KA16ST472J	CARBON RESISTOR
R525,526	2	KA16ST225J	CARBON RESISTOR
R527,528	2	KA16ST473J	CARBON RESISTOR
R529	1	KA16ST104J	CARBON RESISTOR
R601	1	KA16ST224J	CARBON RESISTOR
R602	1	KA16ST102J	CARBON RESISTOR
R603	1	KA50XS471J-LC	CARBON RESISTOR
R604	1	KA16ST103J	CARBON RESISTOR
R605	1	KA16ST562J	CARBON RESISTOR
R606	1	KA16ST102J	CARBON RESISTOR
R607	1	KA50XS222J-LC	CARBON RESISTOR
R608	1	KA16ST103J	CARBON RESISTOR
R609	1	KA16ST222J	CARBON RESISTOR
R610	1	KA16ST101J	CARBON RESISTOR
R611	1	KA16ST561J	CARBON RESISTOR
R612	1	KA16ST221J	CARBON RESISTOR
R613	1	KA16ST474J	CARBON RESISTOR
R614	1	KA16ST221J	CARBON RESISTOR
R615	1	KA16ST223J	CARBON RESISTOR
R616	1	KA16ST104J	CARBON RESISTOR
R617	1	KA16ST101J	CARBON RESISTOR
R619	1	KA16ST102J	CARBON RESISTOR
R621	1	KA16ST103J	CARBON RESISTOR
R622	1	KA16ST560J	CARBON RESISTOR
R624	1	FR25ST690J-LP	FLAME PROOF RESISTOR
R625	1	KA16ST192J	CARBON RESISTOR
R626	1	KA16ST472J	CARBON RESISTOR
R627	1	KA16ST193J	CARBON RESISTOR
R628	1	KA16ST102J	CARBON RESISTOR
SVR101	1	SVR-06T3B104	SEMI-VARIABLE RESISTOR
SVR192	1	SVR-06T3B103	SEMI-VARIABLE RESISTOR
SVR141	1	SVR-06T3B503	SEMI-VARIABLE RESISTOR
SVR142	1	SVR-06T3B103	SEMI-VARIABLE RESISTOR
SVR143	1	SVR-06T3B203	SEMI-VARIABLE RESISTOR
<u>COILS</u>			
L201	1	191015	OSC COIL
L401	1	LAL03101K	INDUCTOR
<u>MISCELLANEOUS</u>			
J602	1	007S240T06-J-J	SOLDER-PLATED WIRE
J603	1	007S240A08-J-J	SOLDER-PLATED WIRE
J604	1	007S240R08-J-J	SOLDER-PLATED WIRE
W902	1	R-020-15	CABLE ASS'Y
W905	1	007S240B08-E-J	SOLDER-PLATED WIRE
4E16	1	OSH-1625-MP	HEAT SINK
CN101	1	EMCS0560MT6	MICRO PLUG
CN102	1	EMCS0660MT6	MICRO PLUG
CN103	1	EMCS0360MT6	MICRO PLUG
CN901	1	EMCS0560MT6B	MICRO PLUG
CN902	1	EMCS0360MT6B	MICRO PLUG
MC301,302	2	TKC-B06X-E1	PCB SOCKET
**MC303	1	TKC-B08X-E1	PCB SOCKET
MC304	1	TKC-B10X-E1	PCB SOCKET
MC601	1	M60-06-080-SA	MICRO SOCKET
MC602	1	MC03-K108	MICRO SOCKET ASS'Y
RJ501	1	T5855-FA	RCA JACK 2P
T9201	1	RT-01T-1.0B	TERMINAL PIN
XL401	1	HC49/417.2872M	QUARTZ OSCILLATOR UNIT

OPERATION PCB ASSY

REF. NU.	Q'TY	PART NO.	DESCRIPTION
<u>P.C. BOARD</u>			
I3E 1	1	OPE-K048B	PRINTED CIRCUIT BOARD
<u>SEMICONDUCTORS</u>			
**L0701,702	2	TLR205	LED
<u>RESISTORS</u>			
**R701,702	2	KA16ST152J	CARBON RESISTOR
*R707,708	2	KA25ST2R0J	CARBON RESISTOR
<u>SWITCHES</u>			
S701-711	11	EV00S405K	TACT SWITCH
<u>MISCELLANEOUS</u>			
W903	1	R-020-15	CABLE ASS'Y
CH301,302	2	TKC-B06P-E1	PCB PLUG
**CN303	1	TKC-B08P-E1	PCB PLUG
CN304	1	TKC-B10P-E1	PCB PLUG
FL701	1	CP2264GM	FLUORESCENCE LAMP
**RX701	1	S8X1483-51	REMOTE SIGNAL RECEIVING UNIT

POWER TRANSFORMER PCB ASSY

REF. NU.	Q'TY	PART NO.	DESCRIPTION
<u>P.C. BOARD</u>			
*I4E13	1	PT-K048-29	PRINTED CIRCUIT BOARD
<u>COILS</u>			
*PT801	1	NPT-K0164	POWER TRANSFORMER
<u>MISCELLANEOUS</u>			
CN601	1	M60-0630134P02	MICRO PLUG

POWER SWITCH PCB ASSY

REF. NU.	Q'TY	PART NO.	DESCRIPTION
<u>P.C. BOARD</u>			
I4E 1	1	S4-K046B	PRINTED CIRCUIT BOARD
<u>CAPACITORS</u>			
C751	1	HE90SJYF223Z	CERAMIC CAPACITOR
<u>SWITCHES</u>			
S751	1	ESB621061	PUSH SWITCH
<u>MISCELLANEOUS</u>			
CN602	1	171826-3	MICRO PLUG

OTHER PARTS

REF. NU.	Q'TY	PART NO.	DESCRIPTION
<u>MISCELLANEOUS</u>			
J901	1	007S260B09-C-C	SOLDER-PLATED WIRE
J902	1	007S260B32-C-C	SOLDER-PLATED WIRE
J903	1	007S260B09-C-C	SOLDER-PLATED WIRE
MC101	1	MZ-PHR03-K104	MICRO SOCKET ASS'Y
MC102	1	MZ-PHR06-K105	MICRO SOCKET ASS'Y
MC901	1	MN-05HUM-K111	MICRO SOCKET ASS'Y
MC902	1	MN-05HUM-K110	MICRO SOCKET ASS'Y
*TU803	1	U9-#03801	UL TYPE TUBE
15E 5	2	BK-1	CORD CLAMP
15E 6	4	OP-80	CORD CLAMP
15E 7	2	ND.5167	CORD CLAMP

UNIT EXPLODED VIEW AND PARTS LIST

MAIN UNIT AND PACKING PARTS

REF. NO.	Q'TY	PART NO.	DESCRIPTION
MISCELLANEOUS			
W901	1	R-027-07	TERMINAL WITH WIRE
1M 1	1	N10511-1	FRONT PANEL
** 1M 3	1	BK3023A-4	TRAY PANEL
** 1M 6	1	N45485-2A	DISPLAY GLASS
1M 9	1	N21707	CABINET
1M10	1	N10513A-2	BOTTOM CHASSIS
1M13	2	TL-034	FOOT
1M15	1	12-3122	POWER KNOB
1M16	2	N31070	TACT BUTTON
1M17	1	N31071	TACT BUTTON
1M18	2	N31073	TACT BUTTON
1M19	2	N45484	TACT BUTTON
1M21	2	N310358	CD HOLDER
1M24	3	KGL5-35	SPACER
1M26	1	N45599	MECH. SPRING
1M28	4	7910652	INSULATION RUBBER A
1M29	2	N45346	DISC CUSHION
1M30	1	N45449	CUSHION
* 2M 5	1	N45502	LASER LABEL
2M 6	1	DM-909	INSTRUCTION (COVER)
* 2M 7	1	N41886-2	POLYETHYLENE BAG (UNIT)
2M 8	1	N40487	POLYETHYLENE BAG (ACCESSORIES)
2M 9	1	TEXT-909-E	INSTRUCTION (TEXT)
2M11	2	N21709	PACKING PAD
2M12	1	N45561	PACKING PAD (CAB1)
* 2M14	1	N21710-2	INNER CARTON
* 2M17	1	NAD-MC2A	CARD,WARRANTY REGISTRATION
2M19	1	N45520	IC LABEL
**2M21	1	N45463-9	REAR LABEL

REF. NO.	Q'TY	PART NO.	DESCRIPTION
* 2M27	1	BK3035	SAFETY INSTRUCTION SHEET
* 2M28	1	N45475	SHEET,PORTABLE CART WARNING
3M 1~M 6	12	TBB*30X10-Y	TAP SCREW B, BIND HEAD, Y
3M 7~M 9,	5	TSB*30X06-Y	TAP SCREW S, BIND HEAD, Y
M11			
3M13	3	TSB*30X06-B	TAP SCREW S, BIND HEAD, B
3M14	1	TSB*30X08-B	TAP SCREW S, BIND HEAD, B
3M16	4	TBB*26X08-Y	TAP SCREW B, BIND HEAD, Y
3M19	2	TBT*30X08-Y	TAP SCREW B, TRUSS HEAD, Y
3M21	3	TPM*30X10-R	TAP SCREW P, ROUND HEAD, R
3M24	2	TSB*40X06-Y	TAP SCREW S, BIND HEAD, Y
3M26	4	BK4093	SPECIAL SCREW
* 15E 1	1	ACC-033E5-4EE1	LINE CORD
* 15E 3	1	SR-4N-4	CORD STOPPER
15E 9	1	VJR-3	SNAKE LUG
* 15E11	1	RC5325	REMOTE CONTROL TRANSMITTER
** 15E12	1	UM-4-2	BATTERY
15E14	1	DM153313C0	CD MECHANISM
15E23	1	PC-063	RCA PIN CORD ASS'Y

P.C. BOARD ASS'Y

REF. NO.	Q'TY	PART NO.	DESCRIPTION
1P 1	1		MAIN PCB ASSY
13P 1	1		OPERATION PCB ASSY
14P 1	1		POWER SWITCH PCB ASSY
14P13	1		POWER TRANSFORMER PCB ASSY

PARTS DESCRIPTION

• Electrolytic

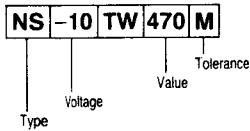

• Mylar - Styrol

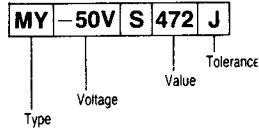

• Ceramic

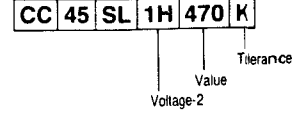
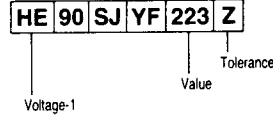

• Electrolytic

Type	Voltage	Value	Tolerance
LL: Low Leak	-10: 10V	R47: 0.47 μ F	K: \pm 10%
NP: Non-Pole	-50: 50V	4R7: 4.7 μ F	M: \pm 20%
NS: Standard	6R3: 6.3V	470: 47 μ F	
		471: 470 μ F	
		472: 4700 μ F	

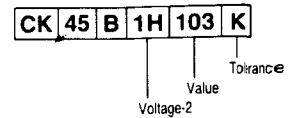

• Mylar - Styrol

Type	Voltage	Value	Tolerance
MY: Mylar	-25V: 25V	4R7: 4.7pF	G: \pm 2%
ST: Styrol	125V: 125V	470: 47pF	J: \pm 5%
	-63T: 63V	471: 470pF	K: \pm 10%
		472: 4700pF	M: \pm 20%
		473: 0.047 μ F	
		474: 0.47 μ F	
		(1000pF=0.001 μ F)	

Voltage-1	Voltage-2	Value	Tolerance
HC: 25V	1E: 25V	4R7: 4.7pF	C: \pm 0.25pF
HE: 50V	1H: 50V	470: 47pF	D: \pm 0.5pF
H: 100V	2H: 500V	471: 470pF	F: \pm 1pF
HK: 250V		472: 4700pF	J: \pm 5%
HM: 500V		473: 0.047 μ F	K: \pm 10%
		474: 0.47 μ F	M: \pm 20%
		(1000pF=0.001 μ F)	Z: +80~-20%

Resistors Description

• Fixed

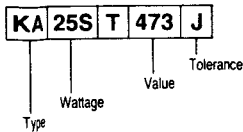

• Semi-Variable

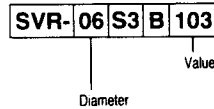

Type	Wattage	Value	Tolerance	Diameter
CE: Cement Case	-2W: 2W	R47: 0.47 Ω	M: \pm 20%	08: 8 ϕ
FR: Flame Proof	10W: 10W	4R7: 4.7 Ω	K: \pm 10%	10: 10 ϕ
KA: Carbon	16S: 1/6W	470: 47 Ω	J: \pm 5%	06: 6 ϕ
MF: Metal Film	20S: 1/5W	471: 470 Ω	G: \pm 2%	
RF: Fusible	25S: 1/4W	472: 4.7k Ω	F: \pm 1%	
SA: Metal Oxide	50S: 1/2W	473: 47k Ω	D: \pm 0.5%	
	50X: 1/2W	474: 470k Ω		
	S3W: 3W	475: 4.7M Ω		

