

**NAD** **SERVICE**  
**MANUAL**

**MONITOR SERIES**

**5100**

**COMPACT DISC PLAYER**

**SAFETY INFORMATION**

**DANGER**—Invisible laser radiation when open and interlock failed or defeated. AVOID DIRECT EXPOSURE TO BEAM.

**CAUTION** - HAZARDOUS LASER AND ELECTROMAGNETIC RADIATION WHEN OPEN AND INTERLOCK DEFEATED  
**ATTENTION** - RAYONNEMENT LASER ET ELECTROMAGNETIQUE DANGEREUX SI OUVERT AVEC L'ENCLICHEMENT DE SECURITE ANNULE

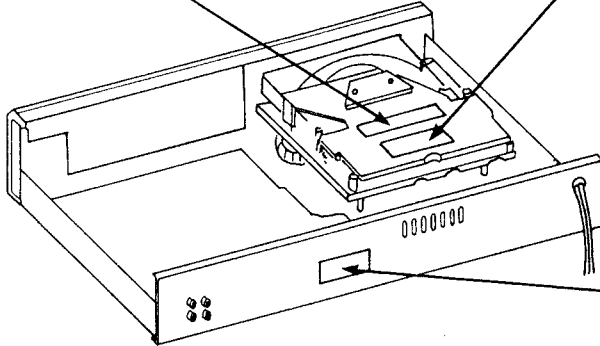

THIS PRODUCT COMPLIES WITH DHHS RULES 21 CFR SUBCHAPTER J PART 1040.10 AND 1040.11 AT DATE OF MANUFACTURE.  
 MANUFACTURED: BEY

**CAUTION**

CAUTION - INVISIBLE LASER RADIATION WHEN OPEN AND INTERLOCKS DEFEATED. AVOID EXPOSURE TO BEAM.  
 VORSICHT! UNSICHTBARE LASERSTRAHLUNG TRITTS AUS. WENN DECKEL GEÖFFNET UND WENN SICHERHEITSVERRIEGELUNG ÜBERBRÜCKT IST. NICHT DEM STRAHL AUSSETZEN!  
 VARNING - OSYNLIG LASERSTRÅLNING NAR DENNA DEL AR ÖPPNAD OCH SPARR AR URKOPPLAD. STRÅLEN AR FARLIG.  
 ADVARSEL - OSYNLIG LASERSTRÅLING VED ÅBNING NAR SIKKERHEDSAFBRYDERE ER UDE AF FUNKTION. UNDGÅ UDSÆTTELSE FOR STRÅLING.

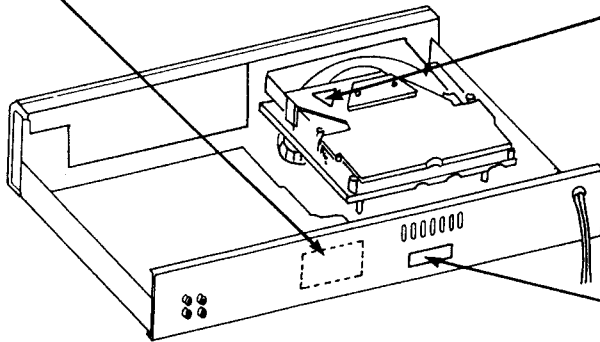

CLASS 1 LASER PRODUCT



The lightning flash with arrowhead, within an equilateral triangle, is intended to alert the user of the presence of uninsulated "dangerous voltage" within the product's enclosure; that may be of sufficient magnitude to constitute a risk of electric shock to persons.



The exclamation point within an equilateral triangle is intended to alert the user of the presence of important operating and maintenance (servicing) instructions in the literature accompanying the appliance.

**REAR PANEL**

1. Fixed-level output jacks.
2. Variable-level output jacks.
3. AC line cord.

**CAUTION**  
 RISK OF ELECTRIC SHOCK  
 DO NOT OPEN

CAUTION TO REDUCE THE RISK OF ELECTRIC SHOCK DO NOT REMOVE COVER (OR BACK). NO USER-SERVICEABLE PARTS INSIDE. REFER SERVICING TO QUALIFIED SERVICE PERSONNEL.

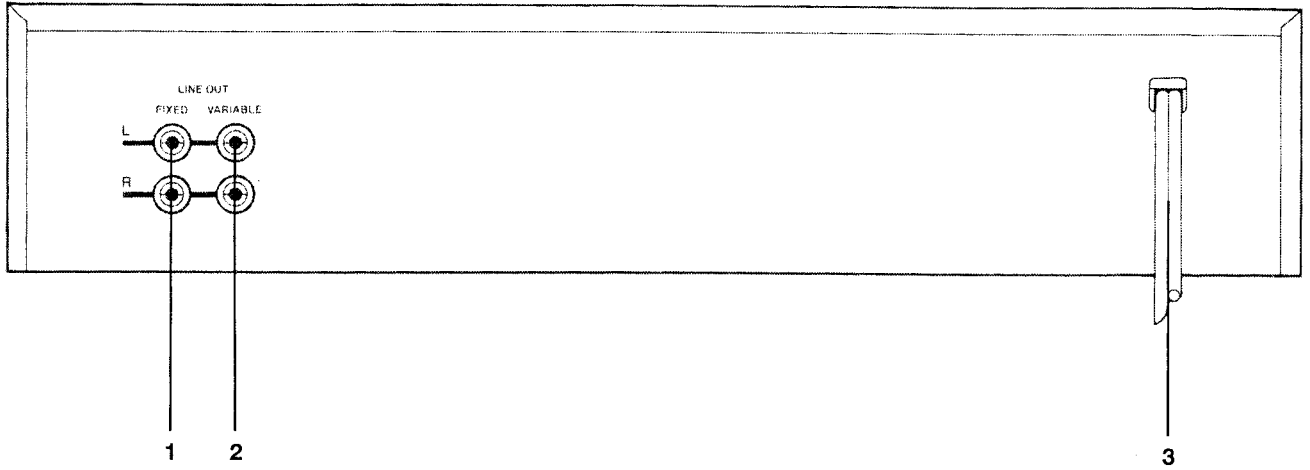

**FRONT PANEL**

- |                                    |                        |
|------------------------------------|------------------------|
| 1. Power on/off.                   | 9. Skip forward/back.  |
| 2. Headphones.                     | 10. Scan forward/back. |
| 3. Disc drawer.                    | 11. Headphone volume.  |
| 4. Open/Close.                     | 12. Play/Pause.        |
| 5. Reset.                          | 13. Memory enter.      |
| 6. Time display selector.          | 14. Program mode.      |
| 7. Repeat.                         | 15. Delete mode.       |
| 8. CDR (controlled dynamic range). | 16. Display.           |

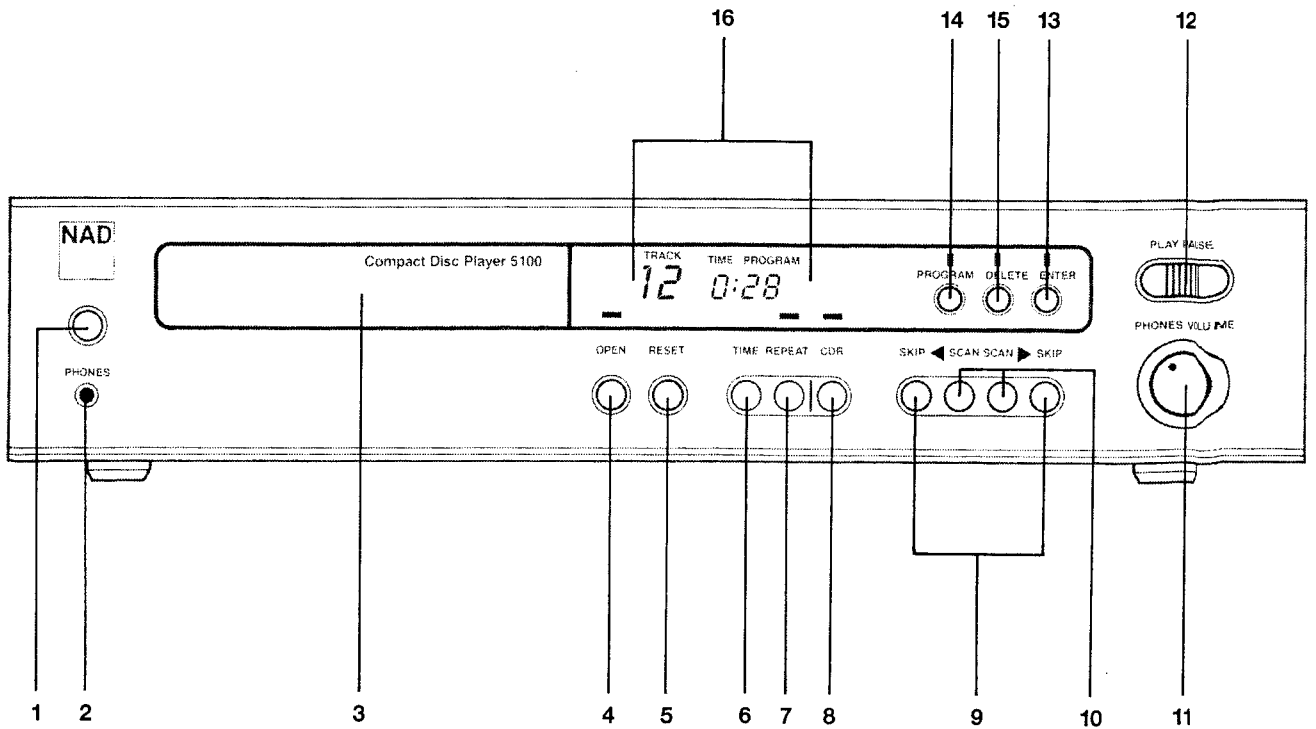

## Contents

	Page
CAUTIONS ON REPLACEMENT OF PICK-UP .....	4
SPECIFICATIONS .....	4
ALIGNMENT PROCEDURES .....	5
ACTION FLOW CHART .....	9
TROUBLE SHOOTING GUIDE .....	10
WIRING DIAGRAM .....	15
BLOCK DIAGRAM .....	17
SCHEMATIC AND PCB LAYOUT .....	19
EXPLODED VIEW AND PARTS LIST .....	25
SCHEMATIC DIAGRAM .....	33
THE DIFFERENCE OF PICK-UP HEAD .....	35

### Cautions on Replacement of Pick-up

1. Do not touch the terminals on the pick-up with your hand when removing the laser pick-up.
2. Cover the working bench with a conductive mat which is also grounded.
3. Before proceeding job, always touch the conductive mat or ground lead with your both hands to discharge electric charges developed on your body.
4. To protect your vision do not expose your eyes to the direct laser light. The beam is focused at a distance of 2 mm from the lens.

### SPECIFICATIONS (at Fixed Output)

	Nominal	Limit	Unit		
Decoding	: 16-bit linear,two channels			Power consumption	: 0.23A (for A,A1)
Frequency response	: +0.2	+1.0	dB	Dimensions	: 25 W (for B,B1,C,C1,C2)
20 Hz-20 kHz	: -0.5	-1.0			: Width 435 mm (17.13 in.)
De-emphasis error	: +0.5	+1.0	dB		: Height 75 mm (2.95 in.)
	: -1	-2.0			: Depth 285 mm (11.22 in.)
Output level at 0 dB	: 2 volts±0.7	±1.0	dB	Net weight	: 5.1 kg (11.2 lb)
Harmonic Distortion	: 0.004	0.01		%	
W/20 kHz L.P.F at 1 kHz				A : USA	
0 dB				A1: CANADA	
Signal-to-Noise Ratio	: 99	90	dB	B : U.K.	
W/20 kHz L.P.F					B1: AUSTRALIA/N.Z.
Channel Separation	: 88	80	dB	C : EUROPE & OTHERS	
W/20 kHz L.P.F at 1 kHz					C1: W.GERMANY
Channel Balance	: 0.5	1.0	dB	C2: G.P.M.	
at 1 kHz 0 dB					
Wow and Flutter	: Unmeasurable				
	(quartz crystal accuracy)				

## ALIGNMENT PROCEDURES

### Measuring instruments

Oscilloscope (Which has a bandwidth of 50 MHz or greater)

Audio frequency oscillator (AF-OSC)

Laser power meter (LEADER LPM-8000 or equivalent)

AC voltmeter (ACVM) – dual channel meters

Frequency counter (FC)

Jitter meter

Test Disc A: YEDS 7 (SONY)

Test Disc B: YEDS 18 (SONY)

Jigs: Filter (See Fig. A)

Special tool (See Fig. F)

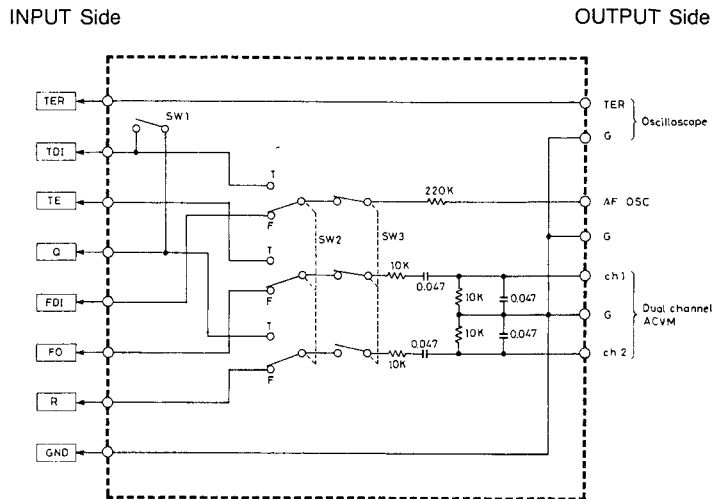

SW1: For diffraction grating and EF balance adjustments

SW2: Focus gain and TRACKING gain switch

SW3: BPF ON/OFF switch

[Fig. A]

### Main P.C.B. test points

Adjustment Jig (with internal filter) connect the filter in Jig before measurement.

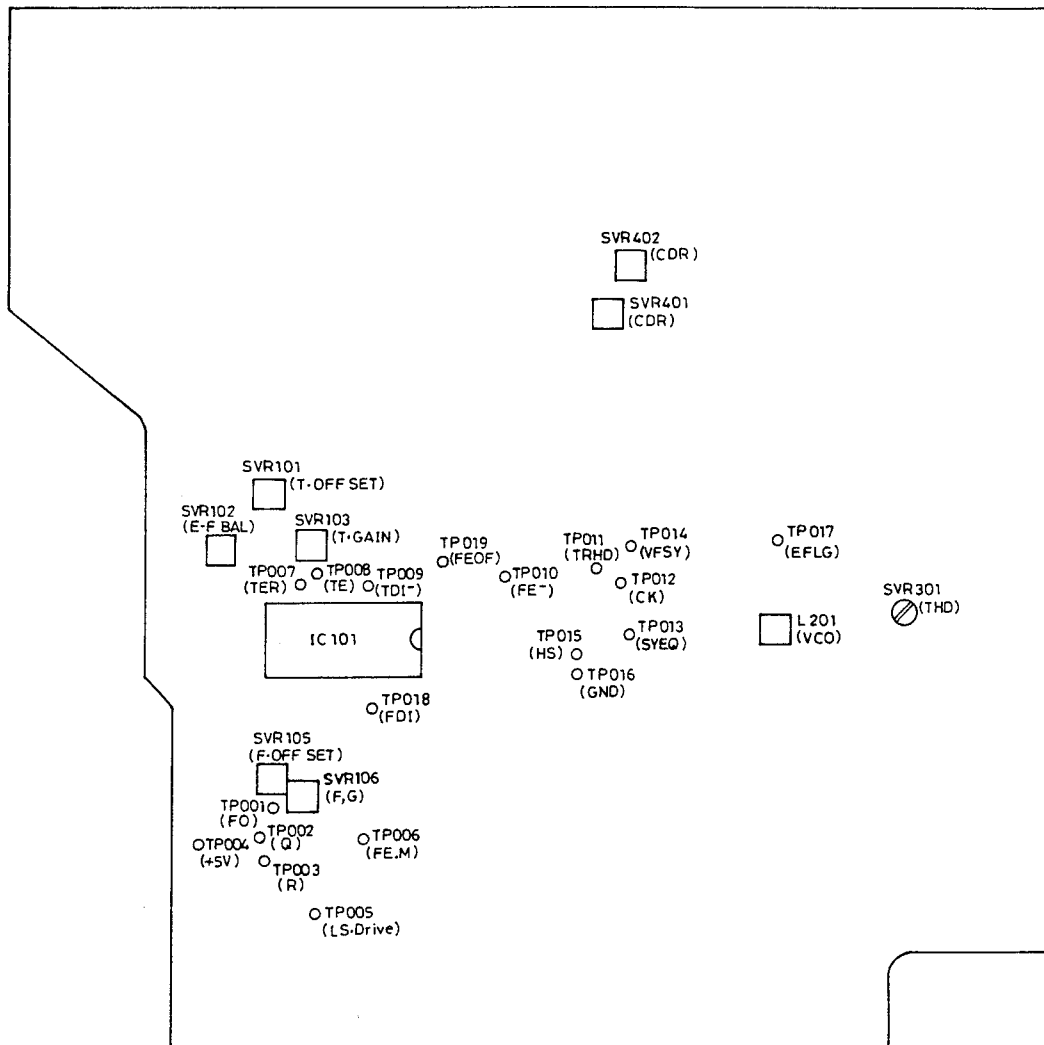

[Fig. B]

### Step 1 Confirmation of Laser Output

- 1) Do not load the disc.
- 2) Apply the laser power meter sensor to the pick-up head as shown in Fig. C.
- 3) Operate from OPEN to CLOSE.
- 4) Measure the laser output during the 6 seconds of FOCUS search mode.

Rating laser output: 0.12 mW to 0.36 mW

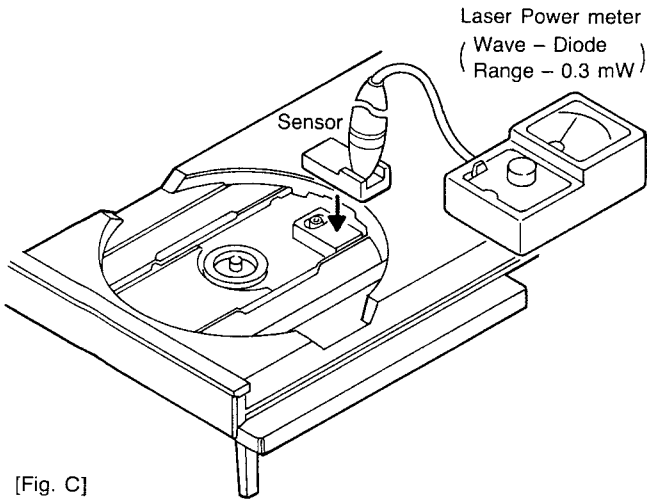

[Fig. C]

### Step 2 Confirmation of Focus Actuator Operation

Oscilloscope Setting  
 DC coupling  
 0.1 V/div when 10:1 probe is used  
 0.5 sec/div or 1 msec/div time

- 1) Do not load the disc.
- 2) Connect the oscilloscope to TP003 [R] and TP016 [GND] points (See Fig. B).
- 3) Press the CLOSE key.
- 4) During 6 seconds of FOCUS search, confirm that the wave-form is as shown in Fig. D.
- 5) Confirm that the pick-up head's objective lens moves smoothly between the lowest and highest points.

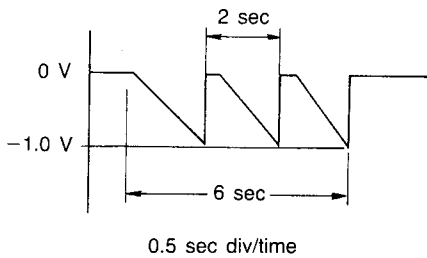

[Fig. D]

### Step 3 Adjustment of Diffraction Grating

#### Caution:

The oscillogram produced during this adjustment procedure can only be displayed for approx 10 sec. After which time the TER signal will automatically go out. Wave-form observation and adjustments should be carried out as quickly as possible. In order to display the wave-form use the following procedure.

Oscilloscope Setting  
 DC coupling  
 10 mV/div when a 10:1 probe is used  
 5 to 20 msec/div time

- 1) Connect the oscilloscope to TP007 [TER] and TP016 [GND] test points.
- 2) Load the test disc. (Test Disc: B)
- 3) Press the CLOSE key (Allow the lead in data on the disc to be read).
- 4) Press the PLAY/PAUSE key twice then in PAUSE mode.
- 5) Put SW1 on the test jig to the ON position (In this position test points TP009 [TDI] and TP002 [Q] will be shorted together) and the wave-form as shown in Fig. E should be displayed on the oscilloscope. In order to prevent the display from going out, put the SW1 OFF and put the SW1 ON again.
- 6) Appear the wave-form like Fig. E on the oscilloscope.
- 7) Using the special tool (See Fig. F) carry out the adjustment (See Fig. G) for maximum amplitude of the displayed signal (See Fig. E).

Rating Signal TER  $\geq 250$  mVp-p

\* If the disc stops rotating and "d!" is displayed on the LED display eject the disc and go back to step 5 - 2).

Oscilloscope Setting Conditions  
 AC coupling  
 50 mV/div when 10:1 probe is used  
 0.2~0.5  $\mu$ sec/div time

- 8) Put SW1 to the OFF position (TP009 [TDI] and TP002 [Q] points open)
- 9) Connect the oscilloscope to test point TP015 [HS] and TP016 [GND].
- 10) Confirm that [HS] (eye-pattern) signal is displayed on the oscilloscope (See Fig. H).

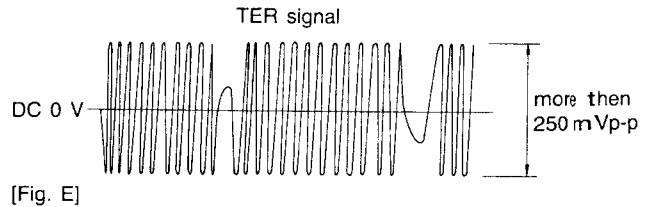

[Fig. E]

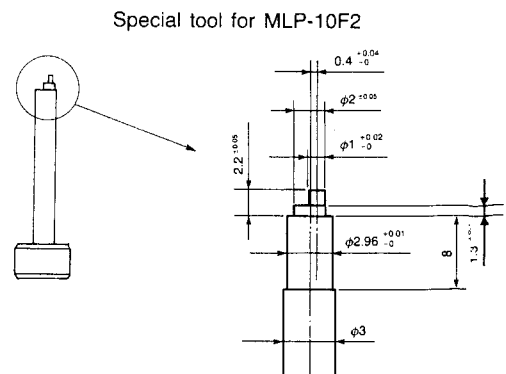

[Fig. F]

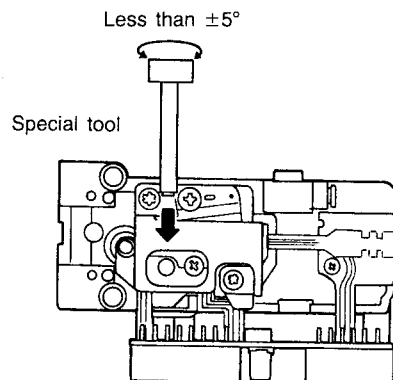

[Fig. G]

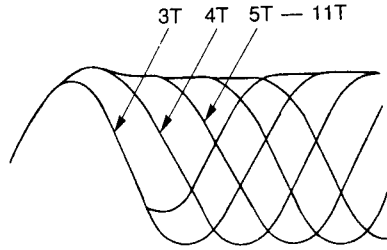

This portion is referred to as the eye pattern.

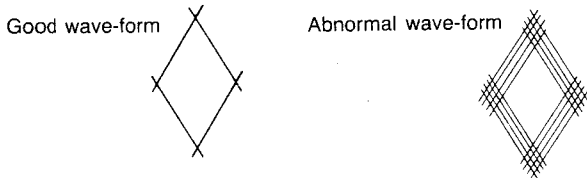

The abnormal eye pattern has less distinct lines and smaller amplitude than that of the good wave-form.

[Fig. H]

**Way of lissajous's figure**

**Oscilloscope Setting**

X input → [E] signal: 5 mV/div when 10:1 probe is used  
 Y input → [HS] signal: 50 mV/div when 10:1 probe is used  
 MODE → X - Y

- 1) Connect the buffer amplifier, as shown in Fig. I between the point [E] and the X input oscilloscope.
- 2) Connect the Y input of point TP015 [HS] and oscilloscope.
- 3) Set the disc in play mode. (Test Disc: B)
- 4) Turn ON the Put SW1. (Short-circuit TP002 [Q] and TP009 [TDI])
- 5) Adjust the special tool until the wave-form is like Fig. J.

**Buffer Amplifier**

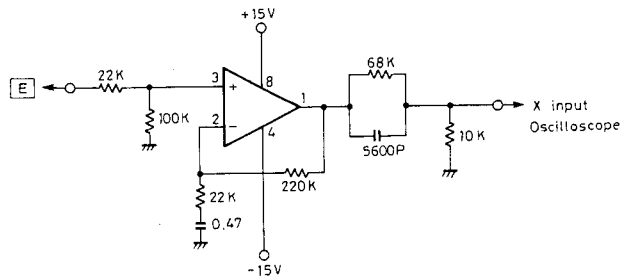

[Fig. I]

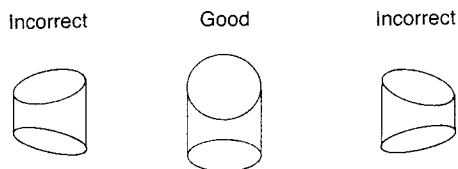

[Fig. J]

**Step 4 Adjustment of EF Balance**

**Oscilloscope Setting**

DC coupling  
 10 mV/div when 10:1 probe is used  
 5 to 20 msec/div time

- 1) Same as from 1) to 6) of step 3.
- 2) Adjust SVR 102 and do like Fig. K.

Rating DC offset — Less than ±15 mV

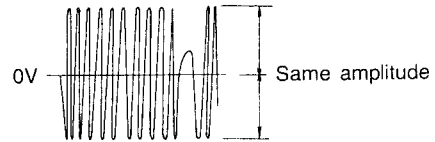

[Fig. K]

**Step 5 Adjustment of Focus Gain**

- 1) Connect the filter and measuring instruments, as shown in Fig. A. Apply 800 Hz, 4.5 Volts RMS signal from the AF oscillator to AF-OSC terminal on Jig.
- 2) Set the SW3 to OFF.
- 3) Set the SW2 to F (FOCUS).
- 4) Load the disc. (Test Disc: B)
- 5) Press the PLAY key.
- 6) Set the SW3 to ON.
- 7) Read the AC voltmeter (CH1: EFO, CH2: ER), adjust SVR106 (FOCUS GAIN) so that they satisfy the rating.

Rating: ER = (EFO + 14 dB) ± 2 dB

**Step 6 Adjustment of Tracking Gain**

- 1) Connect the filter and measuring instruments, as shown in Fig. A. Apply 800 Hz, 100 mVrms signal from the AF oscillator to AF-OSC terminal on Jig.
- 2) Set the SW3 to OFF.
- 3) Set the SW2 to T (TRACKING).
- 4) Load the disc. (Test Disc: B)
- 5) Press the PLAY key.
- 6) Set the SW3 to ON.
- 7) Read the AC voltmeter (CH1: ETE, CH2: EQ) adjust SVR103 (TRACKING) so that they satisfy the rating.

Rating: ETF = (EQ + 11 dB) ± 3 dB

**Step 7 Adjustment of Focus Offset**

**Oscilloscope Setting**

DC coupling  
 10 mV/div range

- 1) Do not load the disc.
- 2) Connect the oscilloscope through the filter shown in Fig. L to TP003 [R] and TP016 [GND] points.
- 3) Do not press the PLAY key.
- 4) Adjust SVR 105 until the level is within 0 V ± 10 mV DC.

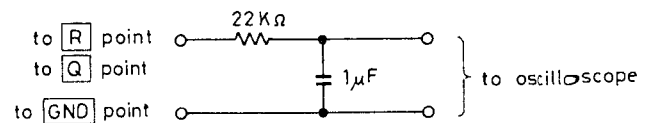

[Fig. L]

### Step 8 Adjustment of Tracking Offset

Oscilloscope Setting

DC coupling

10 mV/div range

- 1) Do not load the disc.
- 2) Connect the oscilloscope through the filter shown in Fig. L to TP002 [Q] and TP016 [GND] points.
- 3) Do not press the PLAY key.
- 4) Adjust SVR 101 until the level is within  $0\text{ V} \pm 10\text{ mV DC}$ .

### Step 9 Confirmation of Kick Gain

Oscilloscope Setting

DC Coupling

CH1 → TP007 [TER] terminal, 0.1 V/div

CH2 → TP011 [TRHD] point, 5 V/div

TRIGGER MODE: CH2

0.2 msec/div time

- 1) Connect the oscilloscope of CH1 to TP007 [TER] terminal on Jig.
- 2) Connect the oscilloscope of CH2 to TP011 [TRHD] point.
- 3) Load the disc. (Test Disc: B)
- 4) Press the PLAY key.
- 5) Press the Fast Forward key.
- 6) Confirm the wave-form, as shown in Fig. M.
- 7) Press the Reverse key.
- 8) Confirm the wave-form, as shown in Fig. M.

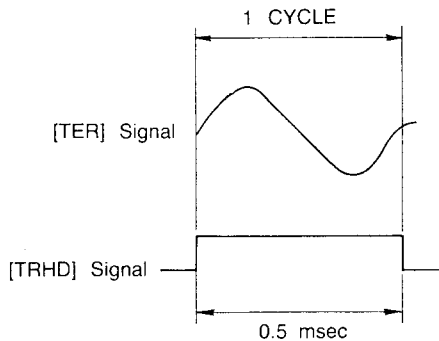

[Fig. M]

### Step 10 Adjustment of VCO

- 1) Connect the Frequency Counter to TP016 [GND] and TP012 [CK]. (See Fig. B)
- 2) Short the TP015 [HS] and TP016 [GND].
- 3) Adjust L201 until the VCO is  $4.3218\text{ MHz} \pm 10\text{ kHz}$ .

### Step 11 Adjustment of THD

- 1) Connect the distortion meter to the output.
- 2) Load the disc. (Test Disc: A)
- 3) Press the play key.
- 4) Press the skip key and keep it pressed until the display shows Track No. 20.
- 5) Adjust the SVR 301 so that the output distortion will be minimum.

**NOTE:** If the input to the distortion meter is not large enough for measurements, use an amplifier of about 30 to 40 dB gain between the CD output and the meter input.

### Step 12 Adjustment of CDR

- 1) Connect the AC voltmeter to the output.
- 2) Load the disc. (Test Disc: A)
- 3) Press the play key.
- 4) Press the skip key and keep it pressed until the display shows Track No. 19.
- 5) Adjust the SVR 401 (left channel) and SVR 402 (right channel) so that the output level with the CDR switch set to ON is 3 dB higher than when the CDR switch is OFF.



# ACTION FLOW CHART

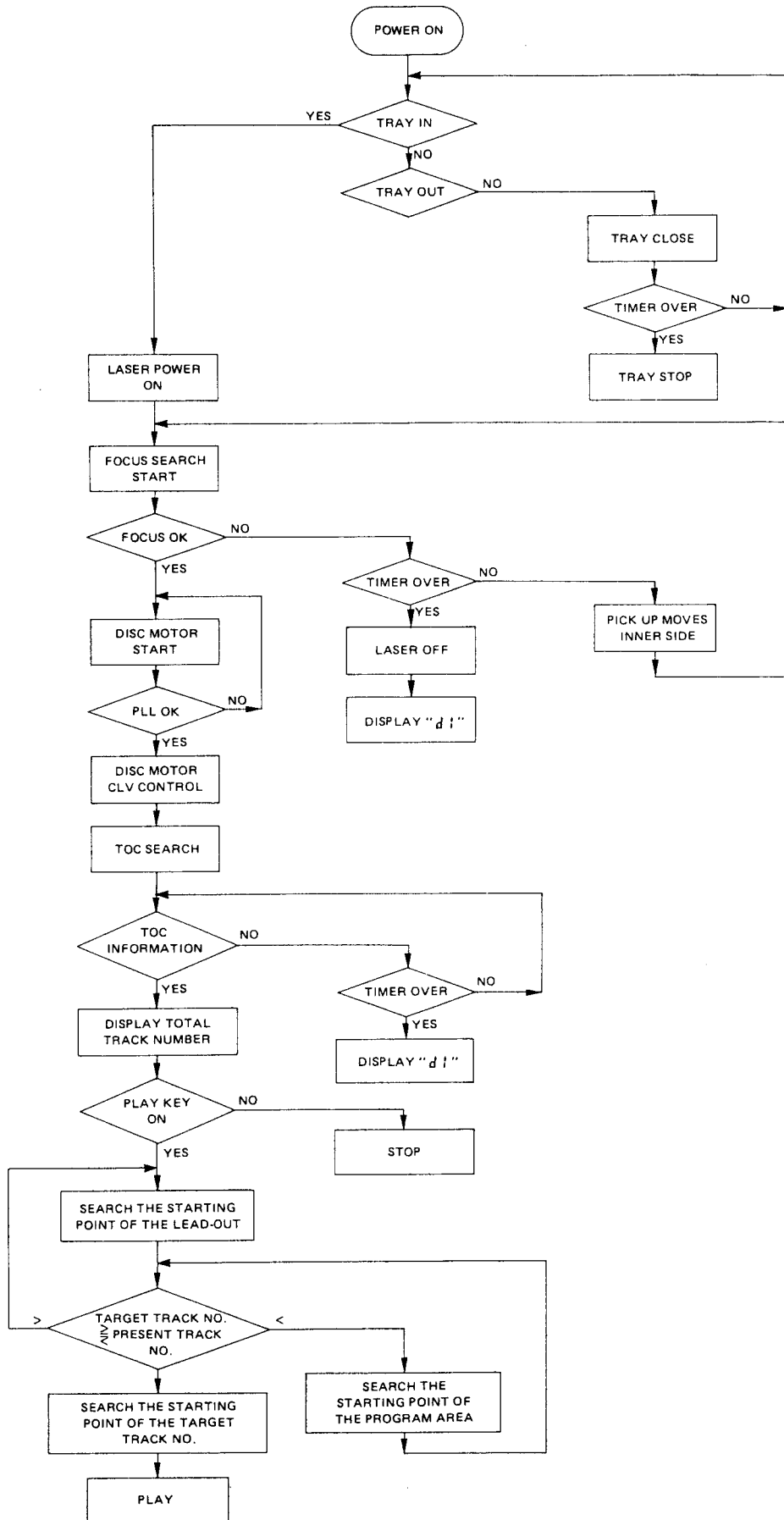

# TROUBLESHOOTING GUIDE

1.

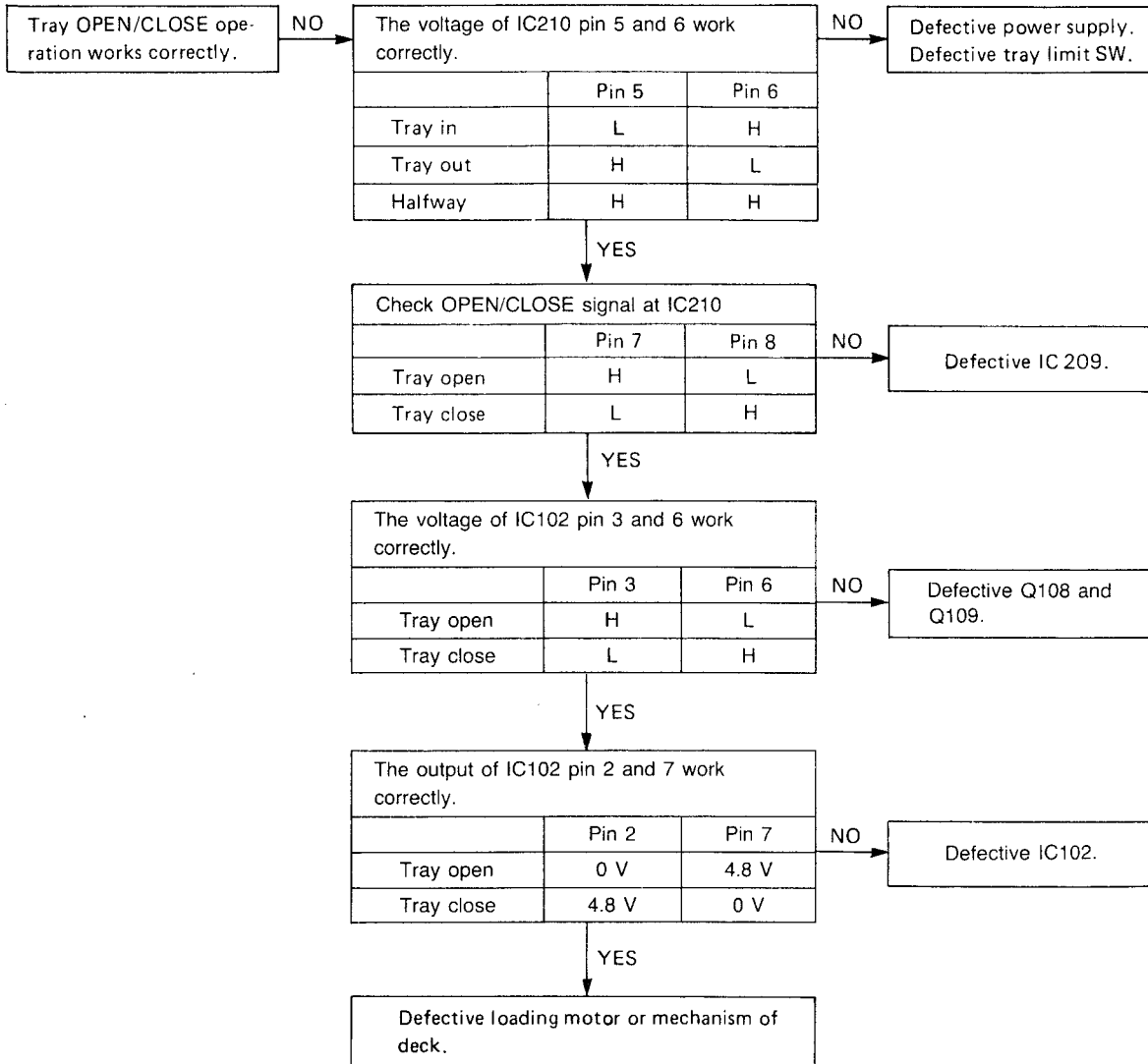

2.

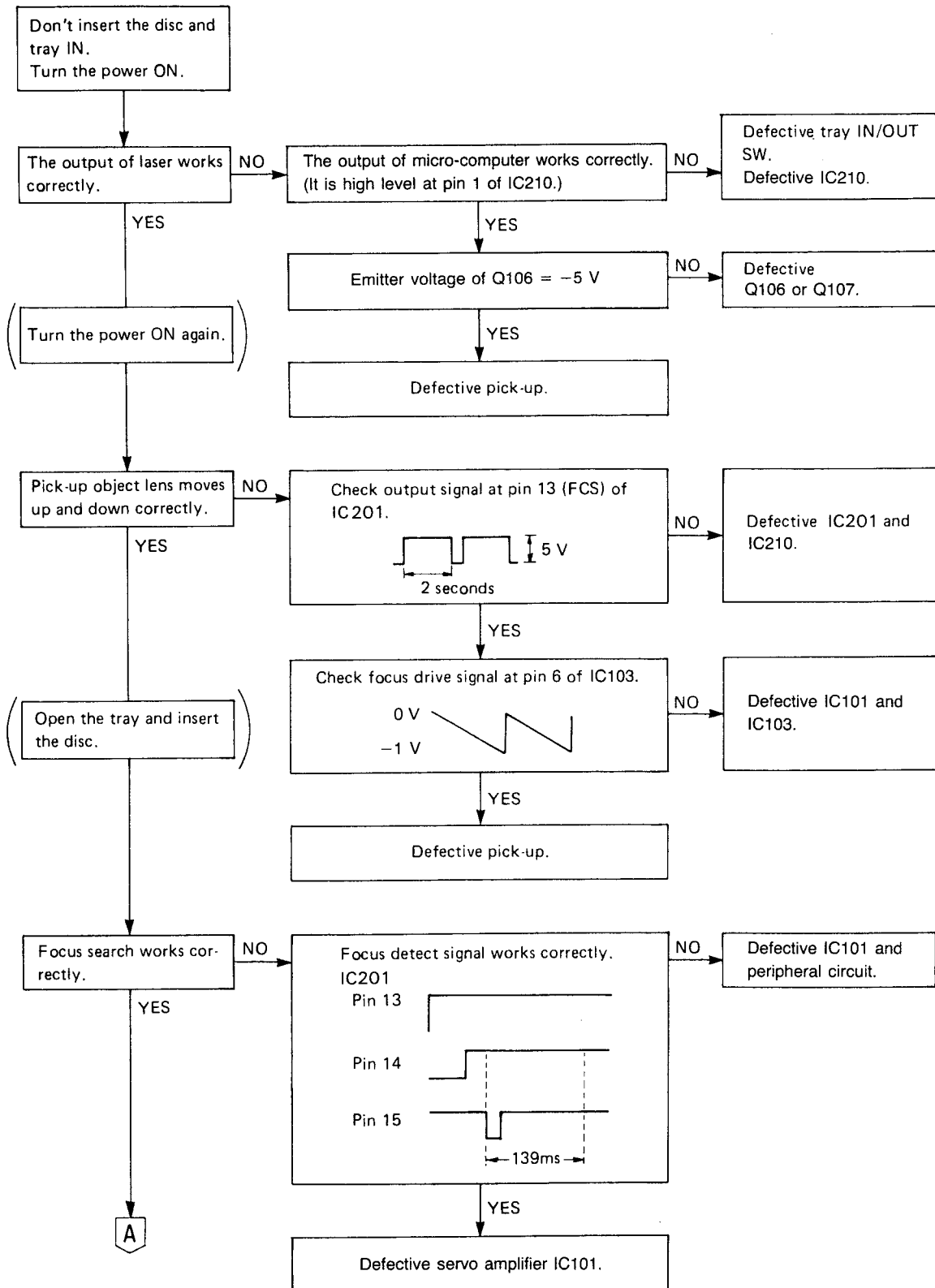

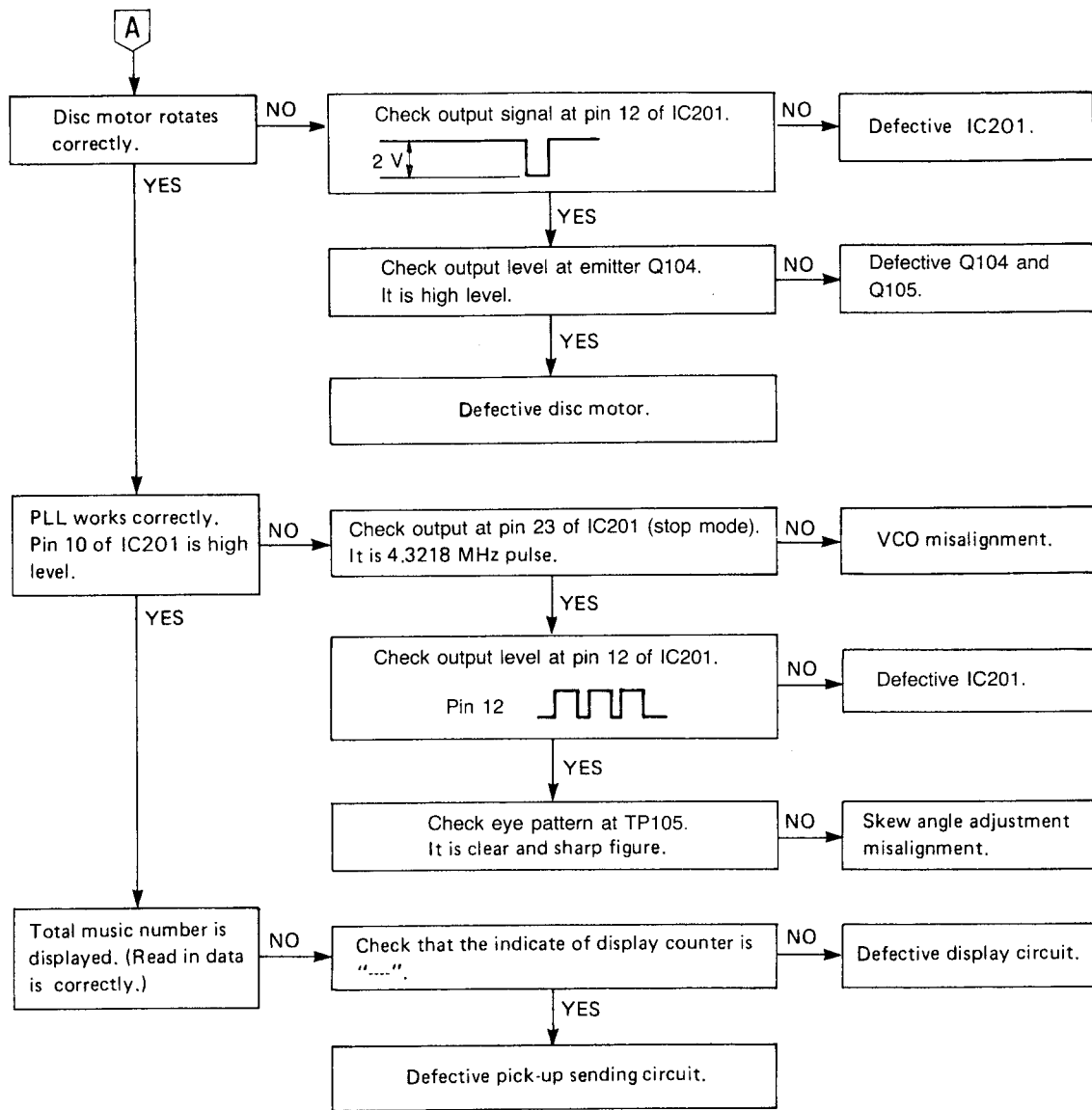

3.

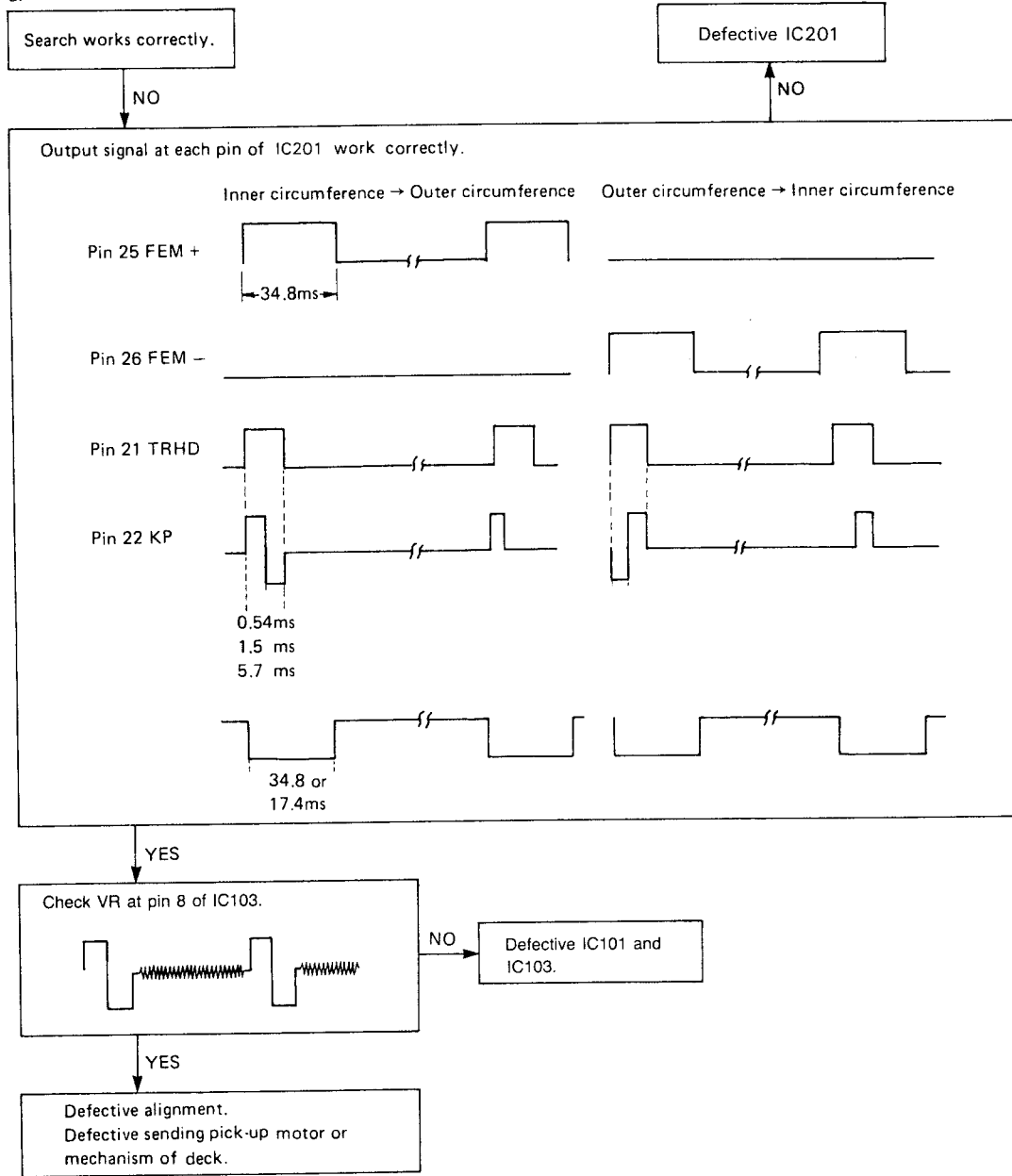

4.

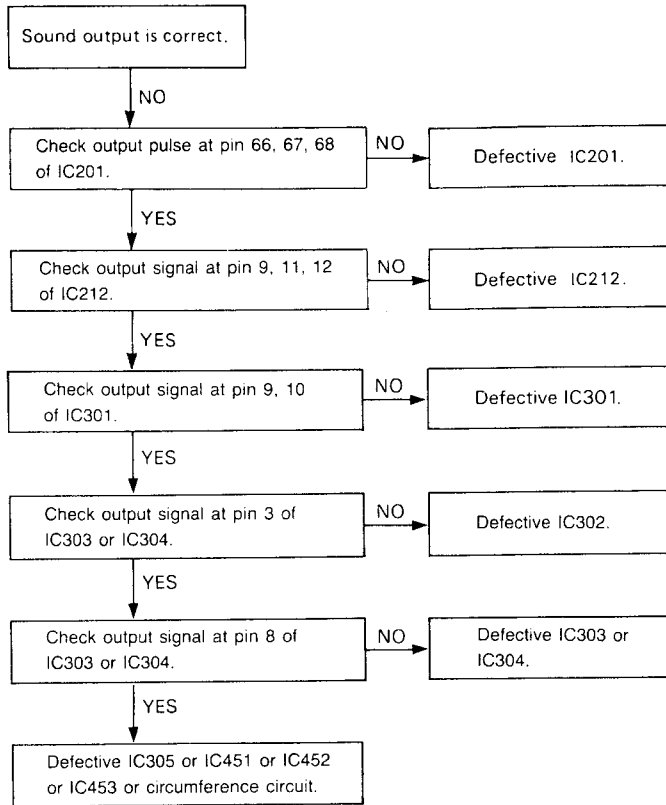

WIRING DIAGRAM(Component side)

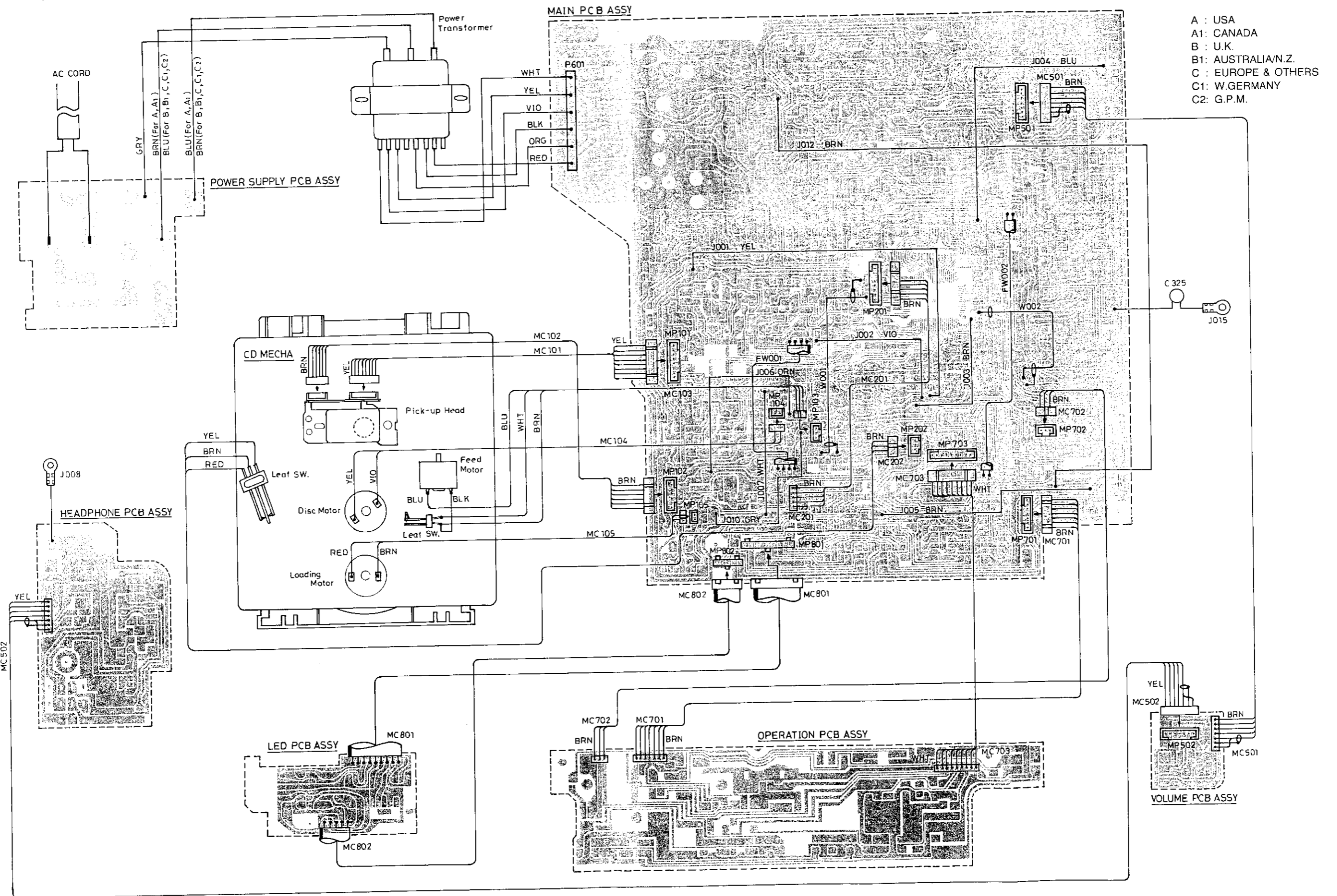

**BLOCK DIAGRAM**

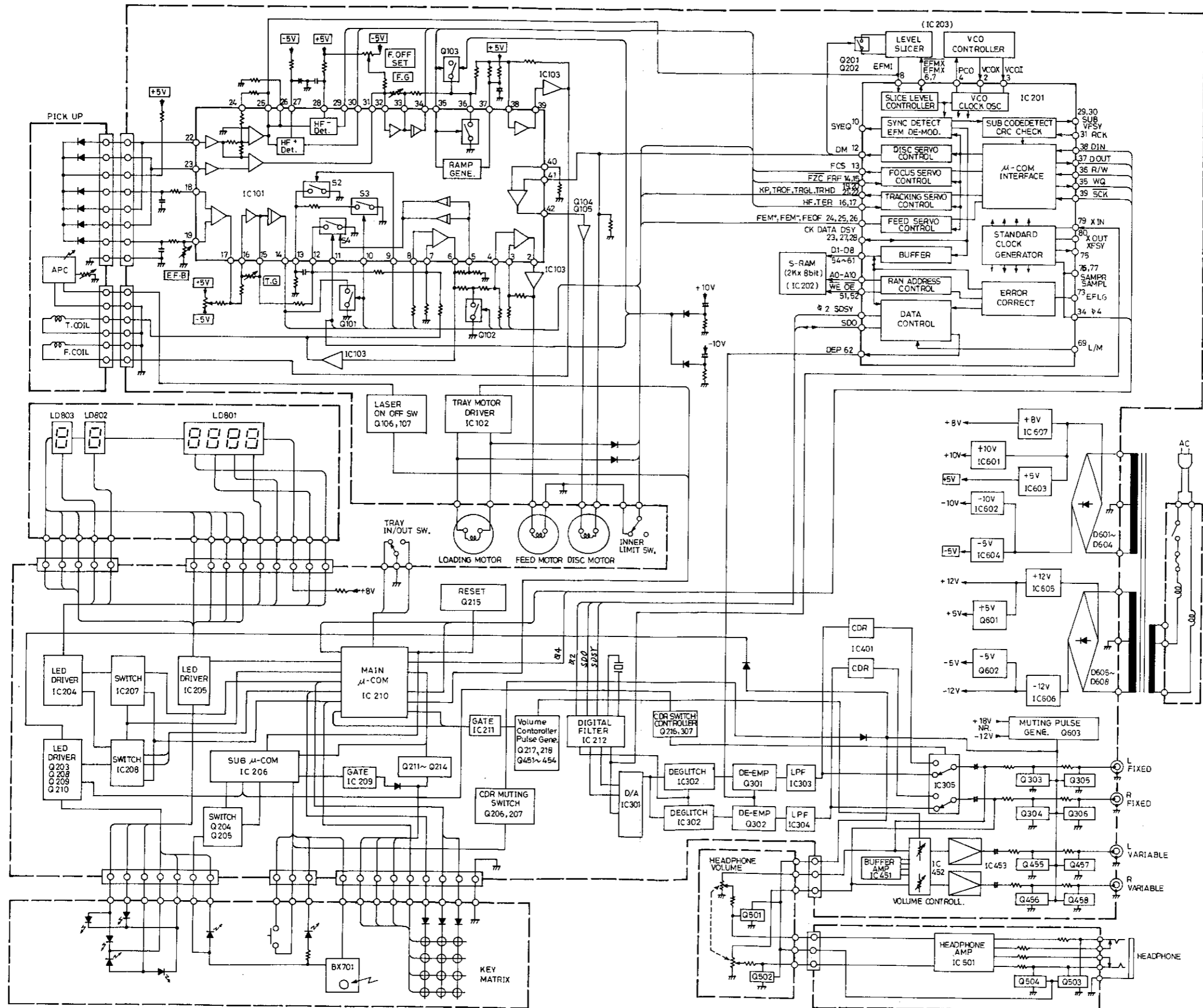



**SCHEMATIC AND PCB LAYOUT(Foil side)**  
LED PCB ASSY

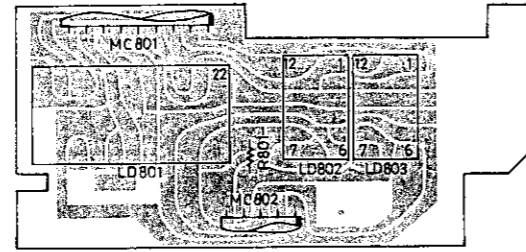
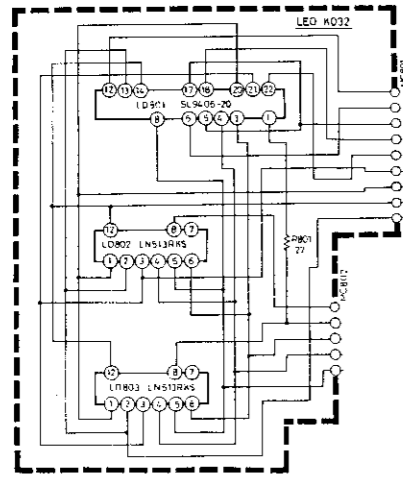

SL9406-20

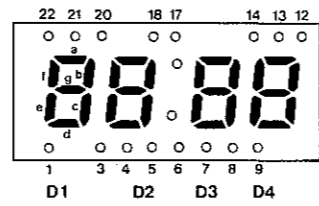

Pin Connection

Pin No.	Address	Pin No.	Address
1	Colon Common (No Pin)	12	D <sub>4</sub> Common
2	a	13	a
3	c	14	g
4	e	15	(No Pin)
5	Lower Colon	16	(No Pin)
6	D <sub>3</sub> Common	17	Upper Colon
7	dp Common	18	D <sub>2</sub> Common
8	d	19	(No Pin)
9	dp	20	b
10	(No Pin)	21	f
11	(No Pin)	22	D <sub>1</sub> Common

LN513RKS

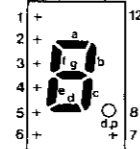

**VOLUME PCB ASSY**

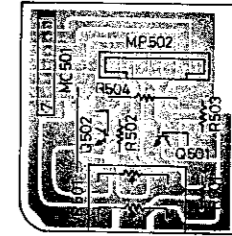
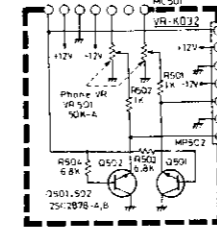

**POWER SUPPLY PCB ASSY**

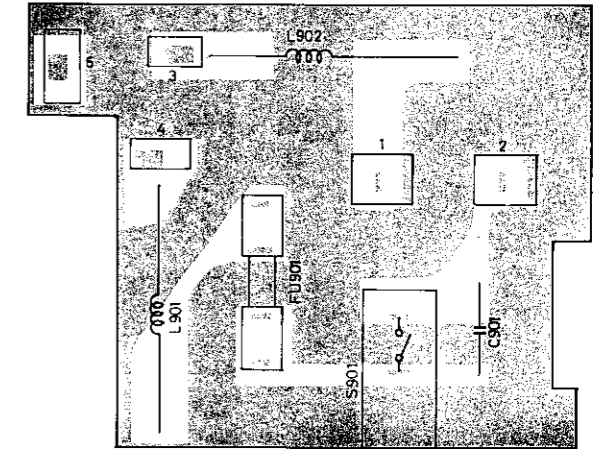
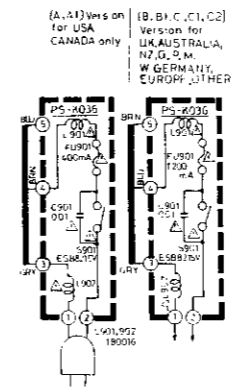

**OPERATION PCB ASSY**

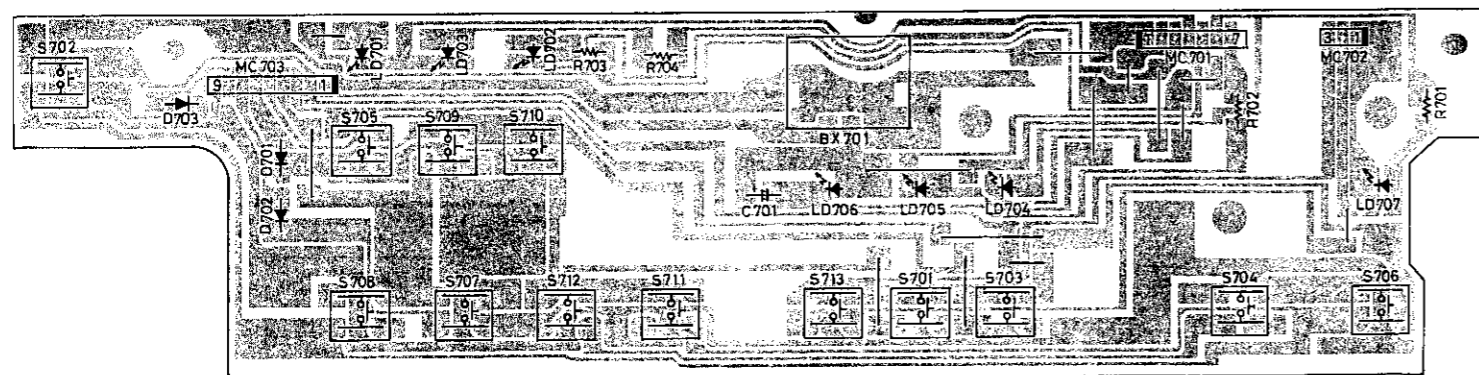
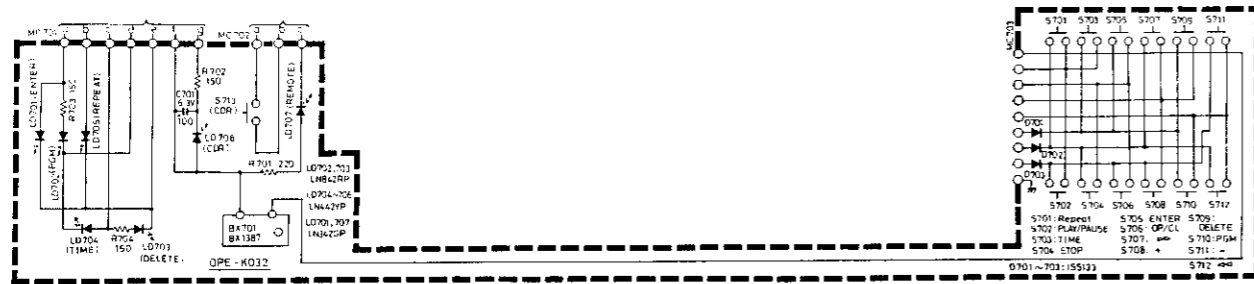

**HEADPHONE PCB ASSY**

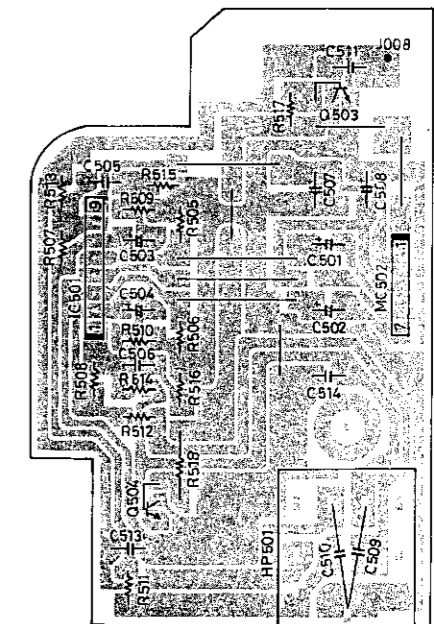
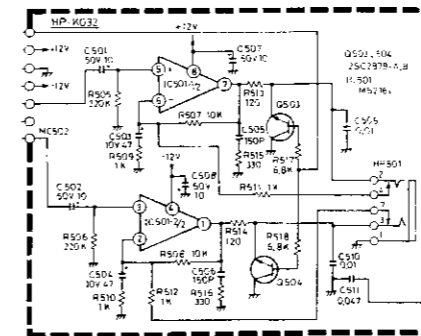

MAIN PCB ASSY

**WARNING:**  
Parts marked with the symbol  $\Delta$  have critical characteristics.  
Use ONLY replacement parts recommended by the manufacturer.

**CAUTION:**  
Before returning the unit to the customer, make sure you make either (1) a leakage current check or (2) a line to chassis resistance check. If the leakage current exceeds 0.5 milliamp, or if the resistance from chassis to either side of the power cord is less than 500 k ohms, the unit is defective.

**WARNING - DO NOT** return the unit to the customer until the problem is located and corrected.

**CAUTION:**  
THOSE FUSES WITH SYMBOL MARKS  $\Delta$  ARE FAST BLOW TYPE. REPLACE WITH SAME TYPE 400 mA 250 V FUSE.

**ATTENTION:**  
LES FUSIBLES MARQUÉS  $\Delta$  SONT DE TYPE A FUSION RAPIDE. UTILISER UN FUSIBLE DE RECHANGE DE TYPE DE 400 mA 250 V.

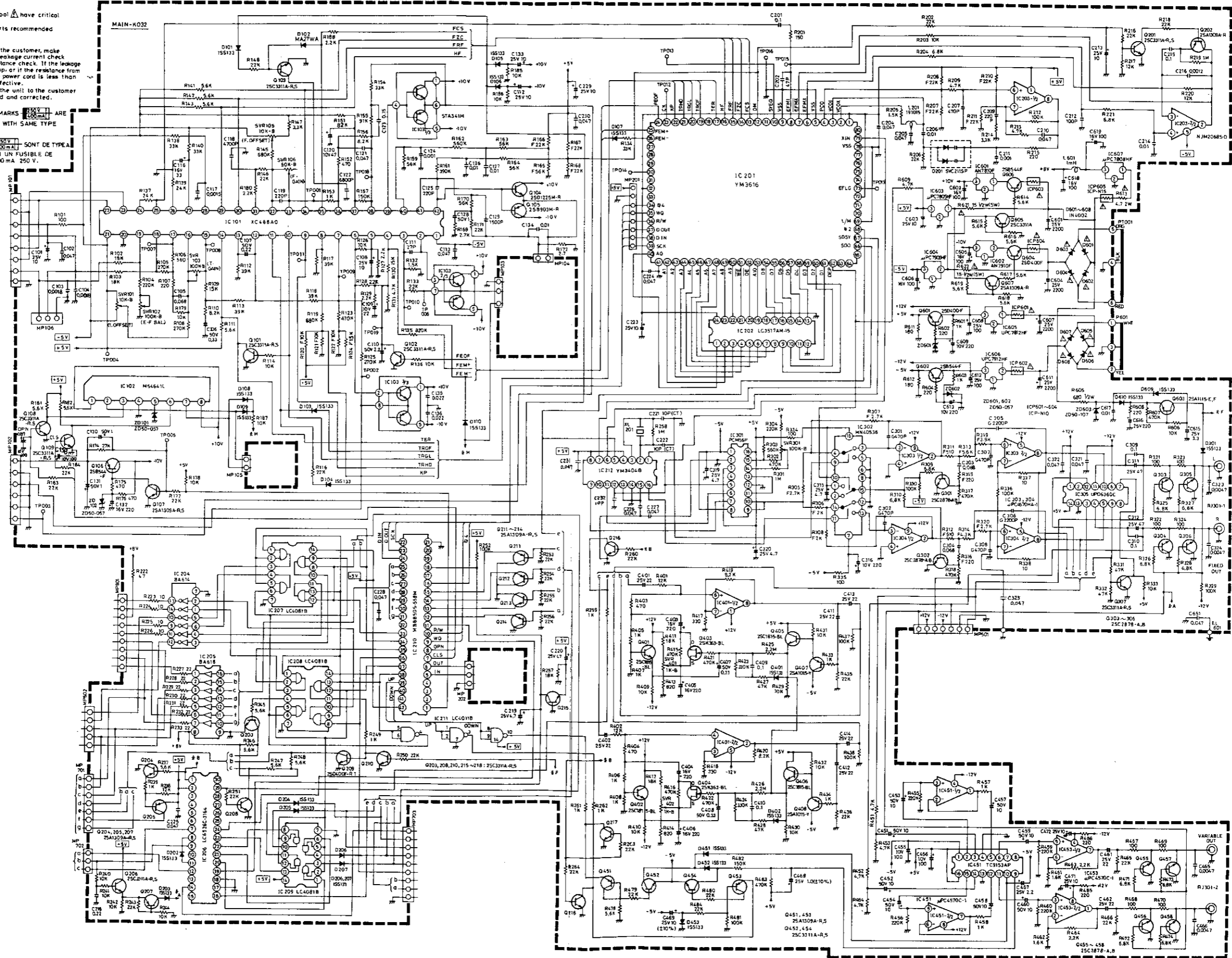

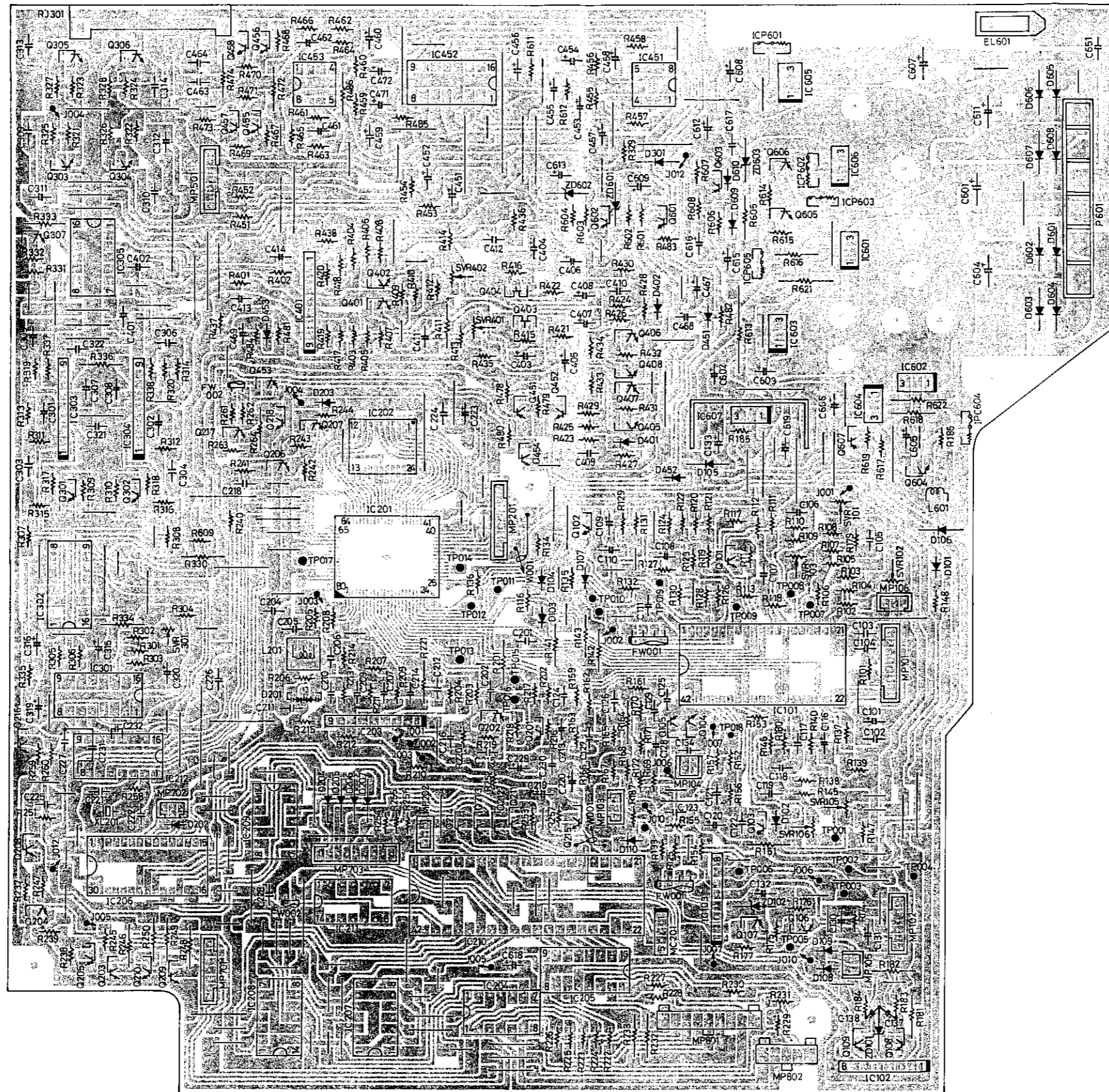

# EXPLODED VIEW AND PARTS LIST

## Main Unit

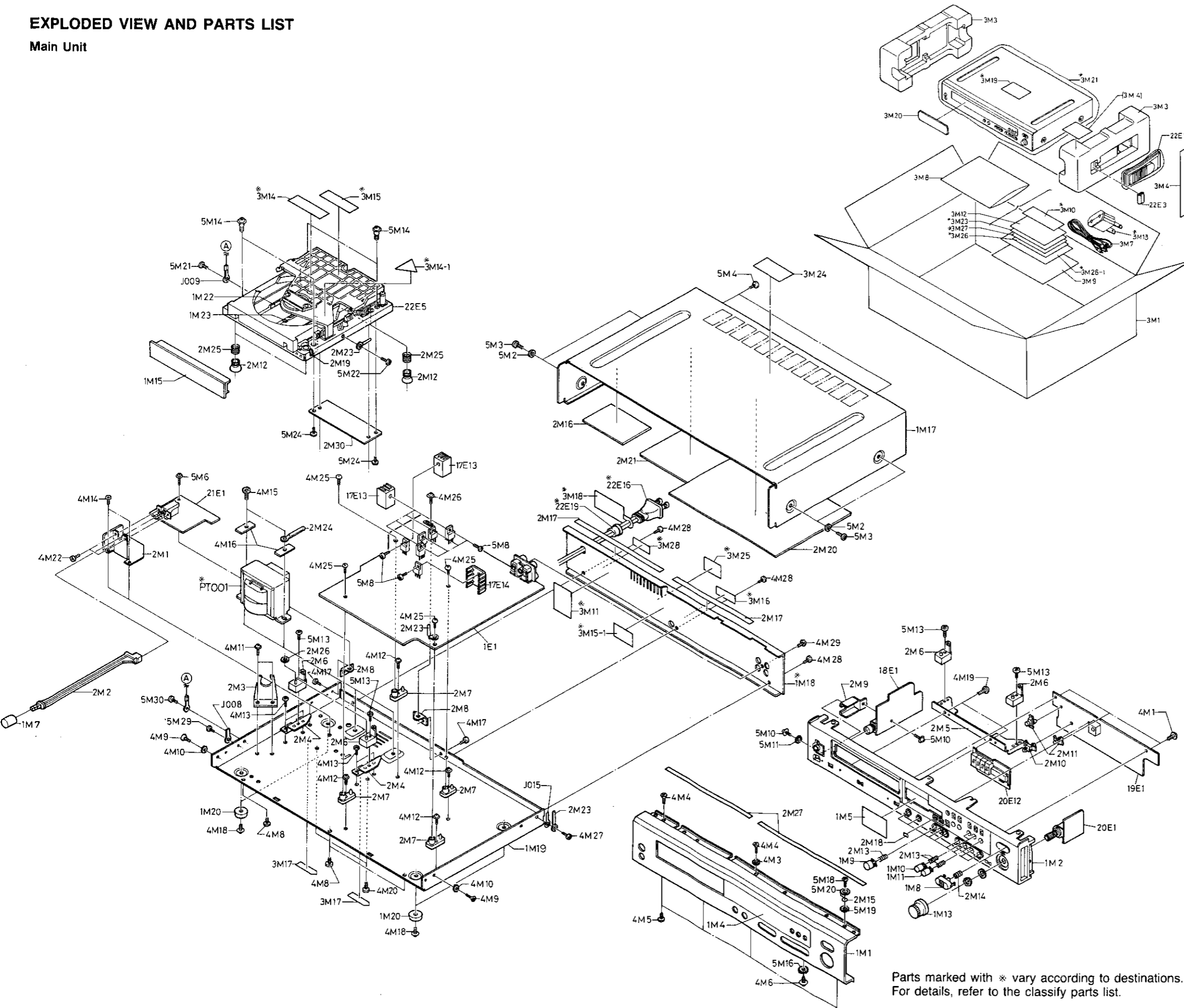

Parts marked with \* vary according to destinations.  
For details, refer to the classify parts list.

REF. NO.	Q'TY	PART NO.	DESCRIPTION
COILS			
PT001	1	HPT-K0104	POWER TRANSFORMER
MISCELLANEOUS			
J008	1	R-020-15	CABLE ASS'Y
J009	1	R-027-15	TERMINAL WITH WIRE
J015	1	R-030-15	CABLE ASS'Y
1M 1	1	BK2033-1	FRONT PANEL
1M 2	1	BK1022B	DISPLAY FRAME
1M 4	1	BK3032	FRONT GLASS
1M 5	1	BK4158	FILTER
1M 7	1	42-1111-1-0	PUSH BUTTON
1M 8	1	N44958-GY	PUSH BUTTON
1M 9	9	N44957-BK	PUSH BUTTON
1M10	2	N44956-BK	PUSH BUTTON
1M11	1	N44988-RD	PUSH BUTTON
1M13	1	BK3025	KNOB (POTENTIOMETER)
1M15	1	BK3023-1	TRAY PANEL
1M17	1	BK2031	CABINET
1M18	1	BK2037	REAR PANEL
1M19	1	BK1021B	BOTTOM CHASSIS
1M20	4	NO.7102A	FOOT
1M22	2	N4534A	DISC CUSHION
1M23	2	BK4176	DISC CUSHION
2M 1	1	BK4068	FITTINGS (SWITCH)
2M 2	1	N42281A	SHAFT (SM)
2M 3	1	NO.2015	ANT. HOLDER
2M 4	2	BK4148	FITTINGS R (CD)
2M 5	1	BK4147	FITTINGS F (CD)
2M 6	4	BK4157	HOLDER
2M 7	4	BK4078	HOLDER
2M 8	2	N42635	FITTINGS (P.C.B.)
2M 9	1	BK4149	JACK HOLDER
2M10	1	XGLS-35	SPACER
2M11	2	KG65-5+95	INSULATION RUBBER B
2M12	4	7900199	SPACER
2M13	12	N44959	KNOB SPRING
2M14	1	N44960	KNOB SPRING
2M15	1	BK4141	EARTH SPRING
2M16	1	BK4196	CUSHION
2M17	2	BK4198	CUSHION
2M18	1	BK4175	SPACER
2M19	2	BK4180	CUSHION TAPE
2M20	1	BK4181A	SHEET A
2M21	1	BK4182A	SHEET B
2M23	3	VJR-3	SNAKE LUG
2M24	1	CS-5	CLIP
2M25	4	BK4145	SPRING
2M26	2	BK4177	WASHER
2M27	2	BK4198	CUSHION
2M30	1	BK4160	PVC PLATE
3M 1	1	BK4150	INNER CARTON
3M 3	2	BK1023	PACKING PAD
3M 4	1	N44894	TAPE/PACKING MATERIAL
3M 7	1	PC-046	RCA PIN CORD ASS'Y
3M 8	1	N40487	POLYETHYLENE BAG (ACCESSORIES)
3M 9	1	OM-K040	INSTRUCTION MANUAL
3M10	1	N44687	CAUTION SHEET, POLARIZED PLUG
3M11	1	N44525	LABEL, FUSE
3M12	1	BK4072	SHEET SHIPPING SCREW
3M14	1	BK4082A	FDA LABEL LASER CAUTION
3M15	1	BK4081A	CSA LABEL LASER CAUTION
3M17	2	N44521	LABEL, CAUTION
3M20	1	BK4159	PROTECTION SHEET
3M21	1	N41886-2	POLYETHYLENE BAG (UNIT)
3M23	1	NAD-WC2A	CARD/WARRANTY REGISTRATION
3M24	1	BK4138	LABEL, WARNING
3M25	1	N44934A	LABEL, UL
3M26	1	BK3035	SAFETY INSTRUCTION SHEET
4M 1	3	TPH+30X08-B	TAP SCREW P, ROUND HEAD, B
4M 3	1	2TWX30	TOOTHED WASHER (B)
4M 4	2	TPS+30X08-Y	TAP SCREW P, FLAT HEAD, Y
4M 5	4	TPH+30X08-B	TAP SCREW P, ROUND HEAD, B
4M 6	1	ZC+10X30X10-2B	TAP SCREW, WASHER FACED, B
4M 8	3	TPH+30X08-B	TAP SCREW P, ROUND HEAD, B
4M 9	2	TPS+30X10-Y	TAP SCREW P, FLAT HEAD, Y
4M10	2	2TWX40-U	WASHER
4M11, M12	6	TSC+30X06-Y	TAP SCREW S, BIND HEAD, Y
4M13	4	TSB+30X04-Y	TAP SCREW S, BIND HEAD, Y
4M14	2	TSB+30X05-Y	TAP SCREW S, BIND HEAD, Y
4M15	2	TSB+40X08-Y	TAP SCREW S, BIND HEAD, Y
4M16	2	2AB-258	REINFORCEMENT (P.T.)
4M17	2	TSO+30X06-B	TAP SCREW S, BIND HEAD, B
4M18	4	TSC+30X06-Y	TAP SCREW S, WASHER FACED, Y
4M19	2	TPH+30X10-Y	TAP SCREW P, ROUND HEAD, Y
4M20	2	SSP+30X04-Y	TAP SCREW P, ROUND HEAD, Y
4M22	4	TPH+30X08-B	TAP SCREW P, ROUND HEAD, B
4M25	4	TPH+30X08-B	TAP SCREW P, ROUND HEAD, B
4M26	1	TSC+30X06-Y	TAP SCREW S, WASHER FACED, Y
4M27	1	TSB+30X06-Y	TAP SCREW S, FLAT HEAD, Y
4M28	3	TSB+30X06-B	TAP SCREW S, BIND HEAD, B
4M29	1	TPH+30X08-B	TAP SCREW P, ROUND HEAD, B
5M 2	4	2AX0840-05-B	PLAIN WASHER, B
5M 3	4	TSB+40X06-B	TAP SCREW S, BIND HEAD, B
5M 4	2	TSB+30X08-B	TAP SCREW S, BIND HEAD, B
5M 6	1	TSC+30X04-Y	TAP SCREW S, BIND HEAD, Y
5M 8	4	TSU+30X08-B	TAP SCREW S, WASHER FACED, B
5M10	2	TSC+30X06-Y	TAP SCREW S, BIND HEAD, Y
5M11	1	2TWX40-U	WASHER
5M13	4	TSB+30X10-Y	TAP SCREW S, BIND HEAD, Y
5M14	4	BK4093	SPECIAL SCREW
5M16	1	3TWX30-U	WASHER
5M18	1	TPS+30X12-N	TAP SCREW P, FLAT HEAD, N
5M19	1	2TWX50-U	WASHER
5M20	1	2AX0840-05-M	WASHER
5M21, M22	2	TSB+30X05-Y	TAP SCREW S, BIND HEAD, Y
5M24	2	TPH+30X08-B	TAP SCREW P, ROUND HEAD, B
5M29, M30	2	TSB+30X05-Y	TAP SCREW S, BIND HEAD, Y
17E13	5	OSH-1625-MP	HEAT SINK
17E14	1	SH-1230	HEAT SINK
22E 1	1	RC-1001-C1	REMOTE CONTROL TRANSMITTER
22E 3	1	UN-3-2	BATTERY
22E 5	1	DM1532280	CD MECHANISM
22E16	1	ACC-033E3+4EC1	LINE CORD
22E19	1	SR-4N-4	CORD STOPPER
22E20	2	NO.5167	CORD CLAMP
22E21, E23	5	BK-1	CORD CLAMP

CD Player Mechanism

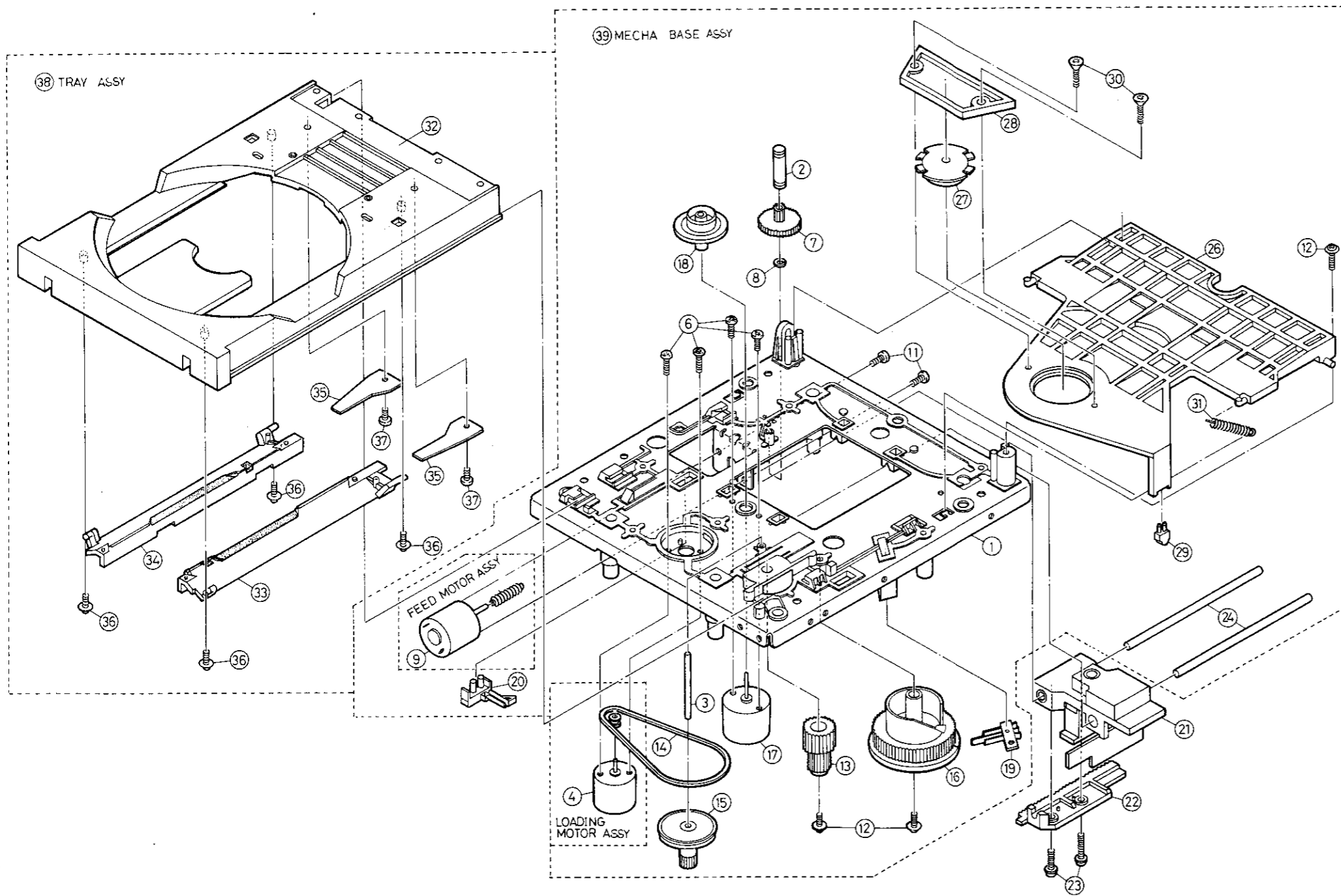

REF. NO.	Q'TY	PART NO.	DESCRIPTION
1	1	7910635	BASE MECHANISM
2	1	7910637	PIN HEAD FEED
3	1	7910638	PIN LOADING
4	1	7900181	LOADING MOTOR ASSY
6	4	7910659	SCREW M2L=4W/SPRING WASHER
7	1	7910642	WORM GEAR W/PINION
8	1	7910643	WASHER
9	1	7900182	FEED MOTOR ASSY
11	2	7910660	SCREW M2L=4W/SPRING WASHER
12	3	7910657	TAPPING SCREW WHI=8
13	1	7910650	FINAL GEAR
14	1	7910651	BELT RUBBER
15	1	7910648	PULLEY B
16	1	7910649	GEAR MAIN
17	1	7900074	MOTOR DISC
18	1	7910639	TURN TABLE
19	1	7910661	LEAF SWITCH 2 POLES
20	1	7900179	LEAF SWITCH MONO POLE
21	1	MLP-10F2	PICK UP HEAD
22	1	7910646	RACK B
23	2	SSPS2+26x08-Y	SCREW M26L=8W/SPRING WASHER
24	2	7910644	FEEDING SHAFT
26	1	7910627	CLAMPER ARM
27	1	7910628	CLAMPER DISC
28	1	7900127	FIXING PLATE
29	1	7900093	BUSHING CLAMP ARM
30	2	7900130	SCREW TAPPING
31	1	7910630	SPRING TENSION
32	1	7910631	TRAY DISC
33	1	7900166	TRAY SUB LEFT
34	1	7900167	TRAY SUB RIGHT
35	2	7900168	TRAY SUB TRAY
36	4	7910658	TAPPING SCREW 1=4
37	2	7900005	TAPPING SCREW
38	1	7900175	TRAY ASSY
39	1	7910647	MECHA BASE ASSY

MAIN PCB ASSY

REF. NO.	Q'TY	PART NO.	DESCRIPTION
<b>P.C. BOARD</b>			
1E 1	1	MAIN-K032A	PRINTED CIRCUIT BOARD
<b>SEMICONDUCTORS</b>			
Q101	1	155133	DIODE
Q102	1	MA27WA	DIODE
Q103-110	8	155133	DIODE
Q201	1	5VC211SP-B+C	DIODE
Q202-207, 301,401, 402,451- 453	12	155133	DIODE
Δ Q601-608	8	1N4002	DIODE
Q609,610	2	155133	DIODE
Q101-103	3	25C3311A-R+S	TRANSISTOR
Q104	1	25D1225M-R	TRANSISTOR
Q105	1	25B909M-R	TRANSISTOR
Q106	1	25B544-F	TRANSISTOR
Q107	1	25A1309A-R+S	TRANSISTOR
Q108,109, 201	3	25C3311A-R+S	TRANSISTOR
Q202	1	25A1309A-R+S	TRANSISTOR
Q203	1	25C3311A-R+S	TRANSISTOR
Q204,205	2	25A1309A-R+S	TRANSISTOR
Q206	1	25C3311A-R+S	TRANSISTOR
Q207	1	25A1309A-R+S	TRANSISTOR
Q208	1	25C3311A-R+S	TRANSISTOR
Q209	1	25D400-F	TRANSISTOR
Q210	1	25C3311A-R+S	TRANSISTOR
Q211-214	4	25A1309A-R+S	TRANSISTOR
Q215-218	4	25C3311A-R+S	TRANSISTOR
Q301-306	6	25C2878-A+B	TRANSISTOR
Q307	1	25C3311A-R+S	TRANSISTOR
Q401,402	2	25C1815-BL	TRANSISTOR
Q403,404	2	25K363-BL	TRANSISTOR
Q405,406	2	25C1815-BL	TRANSISTOR
Q407,408	2	25A1015-Y	TRANSISTOR
Q451	1	25A1309A-R+S	TRANSISTOR
Q452	1	25C3311A-R+S	TRANSISTOR
Q453	1	25A1309A-R+S	TRANSISTOR
Q454	1	25C3311A-R+S	TRANSISTOR
Q455-458	4	25C2878-A+B	TRANSISTOR
Q601	1	25D400-F	TRANSISTOR
Q602	1	25B544-F	TRANSISTOR
Q603	1	25A1115-E,F	TRANSISTOR
Q604	1	25D400-F	TRANSISTOR
Q605	1	25C3311A-R+S	TRANSISTOR
Q606	1	25B544-F	TRANSISTOR
Q607	1	25A1309A-R+S	TRANSISTOR
IC101	1	XC486A0	IC
IC102	1	M54641L	IC
IC103	1	5TA341M	IC
IC201	1	YH3616	IC
IC202	1	LC3517AM-15	IC
IC203	1	NJM20685-D	IC
IC204	1	BA614	IC
IC205	1	BA618	IC
IC206	1	LC6526C-3164	IC
IC207-209	3	LC4081B	IC
IC210	1	M888505-558M	IC
IC211	1	LC4011B	IC
IC212	1	YH3404B	IC
IC301	1	PCM56P	IC
IC302	1	MN4053B	IC
IC303,304	2	UPC4570HA-1	IC
IC305	1	UPD6360C	IC
IC401	1	UPC4570HA-1	IC
IC451	1	UPC4570C-1	IC
IC452	1	TC9153AP	IC
IC453	1	UPC4570C-1	IC
IC601	1	AN7810F	IC
IC602	1	AN7910F	IC
IC603	1	UPC7805HF	IC
IC604	1	UPC7905HF	IC
IC605	1	UPC7812HF	IC
IC606	1	UPC7912HF	IC
IC607	1	UPC7808HF	IC
ZD101,102, 601,602	4	Z050-057	ZENER DIODE,1/2W,5.7V
ZD603	1	Z050-107	ZENER DIODE,1/2W,10.7V
<b>CAPACITORS</b>			
C101	1	NS-25TW100M	ELECTROLYTIC CAPACITOR
C102	1	HC105JZF473Z	CERAMIC CAPACITOR
C103,104	2	MY-50V5182J	MYLAR CAPACITOR
C105	1	MY-50V5683J	MYLAR CAPACITOR
C106	1	NP-50TW33M	ELECTROLYTIC CAPACITOR
C107	1	NP-50TW22M	ELECTROLYTIC CAPACITOR
C108	1	NS-25TW100M	ELECTROLYTIC CAPACITOR
C109	1	NS-10TW220M	ELECTROLYTIC CAPACITOR
C110	1	NS-50TW22M	ELECTROLYTIC CAPACITOR
C111	1	CC455L1H270J	CERAMIC CAPACITOR
C112	1	NS-25TW100M	ELECTROLYTIC CAPACITOR
C116	1	NS-16TW330M	ELECTROLYTIC CAPACITOR
C117	1	MY-50V5152J	MYLAR CAPACITOR
C118	1	MY-50V5472J	MYLAR CAPACITOR
C119	1	CC455L1H221K	CERAMIC CAPACITOR
C120	1	NS-10TW470M	ELECTROLYTIC CAPACITOR
C121	1	MY-50V5473J	MYLAR CAPACITOR
C122	1	MY-50V5682J	MYLAR CAPACITOR
C123	1	ECQV1H154JZ	METALLIZED FILM CAPACITOR
C124	1	MY-50V5102J	MYLAR CAPACITOR
C125	1	CC455L1H221K	CERAMIC CAPACITOR
C126,127	2	MY-50V5103J	MYLAR CAPACITOR

REF. NO.	Q'TY	PART NO.	DESCRIPTION
C128	1	NP-50TW100M	ELECTROLYTIC CAPACITOR
C129	1	MY-50V5152J	MYLAR CAPACITOR
C130,131	2	NS-50TW100M	ELECTROLYTIC CAPACITOR
C132	1	NS-16TW221M	ELECTROLYTIC CAPACITOR
C133	1	NS-25TW100M	ELECTROLYTIC CAPACITOR
C134	1	HE705JYF1037	CERAMIC CAPACITOR
C135,136	2	HC755JZF223Z	CERAMIC CAPACITOR
C137,138	2	NS-10TW101M	ELECTROLYTIC CAPACITOR
C201	1	ECQV1H104JZ	METALLIZED FILM CAPACITOR
C202	1	HE405JSL470J	CERAMIC CAPACITOR
C204	1	HC105JZF473Z	CERAMIC CAPACITOR
C205	1	MY-50V5473J	MYLAR CAPACITOR
C206	1	MY-50V5103J	MYLAR CAPACITOR
C207	1	ECQP-1471JZ	POLYESTER FILM CAPACITOR
C209	1	ECQP-1221JZ	POLYESTER FILM CAPACITOR
C210	1	MY-50V5473J	MYLAR CAPACITOR
C211	1	MY-50V5102J	MYLAR CAPACITOR
C212	1	CC455L1H101J	CERAMIC CAPACITOR
C213	1	NS-25TW100M	ELECTROLYTIC CAPACITOR
C214	1	MY-50V5103J	MYLAR CAPACITOR
C215	1	ECQV1H104JZ	METALLIZED FILM CAPACITOR
C216	1	MY-50V5122J	MYLAR CAPACITOR
C218	1	ECQV1H224JZ	METALLIZED FILM CAPACITOR
C219	1	NS-25TW47M	ELECTROLYTIC CAPACITOR
C220	1	NS-25TW470M	ELECTROLYTIC CAPACITOR
C221,222	2	CC455L1H100J	CERAMIC CAPACITOR
C223	1	NS-25TW100M	ELECTROLYTIC CAPACITOR
C224-228	5	HC105JZF473Z	CERAMIC CAPACITOR
C229	1	NS-25TW100M	ELECTROLYTIC CAPACITOR
C230	1	HC105JZF473Z	CERAMIC CAPACITOR
C231	1	CK45F1H4732A	CERAMIC CAPACITOR
C232	1	CC455L1H100D	CERAMIC CAPACITOR
C301,302	2	C015P1H471GZKF	POLYESTER FILM CAPACITOR
C303,304	2	ECQM1H683JV	POLYESTER FILM CAPACITOR
C305,306	2	ECOP1H222GZ	POLYESTER FILM CAPACITOR
C307,308	2	C015P1H471GZKF	POLYESTER FILM CAPACITOR
C309,310	2	ECQV1H104JZ	METALLIZED FILM CAPACITOR
C311,312	2	NP-25TW470M-KF	ELECTROLYTIC CAPACITOR
C315	1	NS-25TW47M	ELECTROLYTIC CAPACITOR
C316	1	NS-10TW221M	ELECTROLYTIC CAPACITOR
C319,320	2	NS-25TW47M	ELECTROLYTIC CAPACITOR
C321,322	2	HC105JZF473Z	CERAMIC CAPACITOR
C323,324	2	MY-50V5472J	MYLAR CAPACITOR
C325	1	CK45F1H4732A	CERAMIC CAPACITOR
C401,402	2	NP-25TW220M	ELECTROLYTIC CAPACITOR
C403,406	4	NS-16TW221M	ELECTROLYTIC CAPACITOR
C407,408	2	NS-50TW33M	ELECTROLYTIC CAPACITOR
C409,410	2	ECQV1H104JZ	METALLIZED FILM CAPACITOR
C411-414	4	NP-25TW220M	ELECTROLYTIC CAPACITOR
C451,454	4	NS-50TW100M	ELECTROLYTIC CAPACITOR
C455,456	2	NS-10TW101M	ELECTROLYTIC CAPACITOR
C457,460	4	NS-50TW100M	ELECTROLYTIC CAPACITOR
C461,462	2	NP-25TW220M	ELECTROLYTIC CAPACITOR
C465,466	2	MY-50V5472J	MYLAR CAPACITOR
C467	1	NS-25TW22M	ELECTROLYTIC CAPACITOR
C468	1	UVX1H010KAA1TA	ELECTROLYTIC CAPACITOR
C469	1	UVX1E100KAA1TA	ELECTROLYTIC CAPACITOR
C471,472	2	NS-25TW100M	ELECTROLYTIC CAPACITOR
C601	1	NS-25TW22M-KF	ELECTROLYTIC CAPACITOR
C602	1	NS-16TW101M	ELECTROLYTIC CAPACITOR
C603	1	NS-25TW100M	ELECTROLYTIC CAPACITOR
C604	1	NS-25TW22M-KF	ELECTROLYTIC CAPACITOR
C605,606	2	NS-16TW101M	ELECTROLYTIC CAPACITOR
C607	1	NS-25TW22M-KF	ELECTROLYTIC CAPACITOR
C608	1	NS-25TW101M	ELECTROLYTIC CAPACITOR
C609	1	NS-10TW221M	ELECTROLYTIC CAPACITOR
C611	1	NS-25TW22M-KF	ELECTROLYTIC CAPACITOR
C612	1	NS-25TW101M	ELECTROLYTIC CAPACITOR
C613	1	NS-10TW221M	ELECTROLYTIC CAPACITOR
C615	1	NS-25TW33M	ELECTROLYTIC CAPACITOR
C616	1	NS-25TW221M	ELECTROLYTIC CAPACITOR
C617	1	MY-50V5103J	MYLAR CAPACITOR
C618,619	2	NS-16TW101M	ELECTROLYTIC CAPACITOR
C651	1	HC105JZF473Z	CERAMIC CAPACITOR
<b>RESISTORS</b>			
R101	1	KA165T101J	CARBON RESISTOR
R102,103	2	KA165T183J	CARBON RESISTOR
R104	1	KA165T224J	CARBON RESISTOR
R105	1	KA165T274J	CARBON RESISTOR
R106	1	KA165T561J	CARBON RESISTOR
R107	1	KA165T221J	CARBON RESISTOR
R108	1	KA165T274J	CARBON RESISTOR
R109	1	KA165T153J	CARBON RESISTOR
R110	1	KA165T822J	CARBON RESISTOR
R111	1	KA165T562J	CARBON RESISTOR
R112,113	2	KA165T393J	CARBON RESISTOR
R114	1	KA165T103J	CARBON RESISTOR
R116	1	KA165T223J	CARBON RESISTOR
R117,118	2	KA165T393J	CARBON RESISTOR
R119	1	KA165T684J	CARBON RESISTOR
R120-122	3	MF165T103F	METAL FILM RESISTOR
R123	1	KA165T474J	CARBON RESISTOR
R124	1	MF165T153F	METAL FILM RESISTOR
R125	1	KA165T274J	CARBON RESISTOR
R126	1	KA165T103J	CARBON RESISTOR
R127	1	KA165T222J	CARBON RESISTOR
R128	1	KA165T223J	CARBON RESISTOR
R129	1	KA165T222J	CARBON RESISTOR
R130	1	KA165T153J	CARBON RESISTOR
R131	1	KA165T472J	CARBON RESISTOR
R132	1	KA165T152J	CARBON RESISTOR
R133	1	KA165T223J	CARBON RESISTOR
R134	1	KA165T333J	CARBON RESISTOR
R135	1	KA165T824J	CARBON RESISTOR
R136	1	KA165T103J	CARBON RESISTOR
R137	1	KA165T243J	CARBON RESISTOR

REF. NO.	Q'TY	PART NO.	DESCRIPTION
R138	1	KA165T333J	CARBON RESISTOR
R139	1	KA165T243J	CARBON RESISTOR
R140	1	KA165T333J	CARBON RESISTOR
R141-143	3	KA165T562J	CARBON RESISTOR
R145	1	KA165T684J	CARBON RESISTOR
R146	1	KA165T223J	CARBON RESISTOR
R147	1	KA165T332J	CARBON RESISTOR
R148	1	KA165T223J	CARBON RESISTOR
R151	1	KA165T823J	CARBON RESISTOR
R152	1	KA165T471J	CARBON RESISTOR
R153	1	KA165T102J	CARBON RESISTOR
R154	1	KA165T333J	CARBON RESISTOR
R155	1	KA165T913J	CARBON RESISTOR
R156	1	KA165T822J	CARBON RESISTOR
R157	1	KA165T154J	CARBON RESISTOR
R159	1	KA165T563J	CARBON RESISTOR
R161	1	KA165T394J	CARBON RESISTOR
R162	1	KA165T564J	CARBON RESISTOR
R163,164	2	KA165T563J	CARBON RESISTOR
R165	1	MF165T563F	METAL FILM RESISTOR
R166-168	3	MF165T223F	METAL FILM RESISTOR
R169	1	KA165T272J	CARBON RESISTOR
R170	1	KA165T563J	CARBON RESISTOR
R171	1	KA165T223J	CARBON RESISTOR
R172	1	KA165T272J	CARBON RESISTOR
R174	1	KA165T273J	CARBON RESISTOR
R175,176	2	KA165T471J	CARBON RESISTOR
R177	1	KA165T223J	CARBON RESISTOR
R178,179	2	KA165T103J	CARBON RESISTOR
R180	1	KA165T222J	CARBON RESISTOR
R181,182	2	KA165T562J	CARBON RESISTOR
R183,184	2	KA165T223J	CARBON RESISTOR
R185-187	3	KA165T103J	CARBON RESISTOR
R188	1	KA165T222J	CARBON RESISTOR
R201	1	KA165T151J	CARBON RESISTOR
R202	1	KA165T223J	CARBON RESISTOR
R203	1	KA165T103J	CARBON RESISTOR
R204	1	KA165T682J	CARBON RESISTOR

**HEADPHONE PCB ASSY**

REF. NO.	Q'TY	PART NO.	DESCRIPTION
<b>P.C. BOARD</b>			
18E1	1	HP-K032A	PRINTED CIRCUIT BOARD
<b>SEMICONDUCTORS</b>			
Q503,504	2	25C2878-A+B	TRANSISTOR
IC501	1	M5216L	IC
<b>CAPACITORS</b>			
C501,502	2	NS-50TW100M	ELECTROLYTIC CAPACITOR
C503,504	2	NS-10TW470M	ELECTROLYTIC CAPACITOR
C505,506	2	HE60SJS151J	CERAMIC CAPACITOR
C507,508	2	NS-50TW100M	ELECTROLYTIC CAPACITOR
C509,510	2	HE70SJV103Z	CERAMIC CAPACITOR
C511	1	HC10SJV473Z	CERAMIC CAPACITOR
<b>RESISTORS</b>			
R505,506	2	KA16ST224J	CARBON RESISTOR
R507,508	2	KA16ST103J	CARBON RESISTOR
R509,512	4	KA16ST102J	CARBON RESISTOR
R513,514	2	KA16ST121J	CARBON RESISTOR
R515,516	2	KA16ST331J	CARBON RESISTOR
R517,518	2	KA16ST602J	CARBON RESISTOR
<b>MISCELLANEOUS</b>			
HP501	1	HLJ430B-01-30B	H.P. JACK
MC502	1	MT-22A07F-K063	MICRO SOCKET ASS'Y
TU001-004	4	U9-#188005	UL TYPE TUBE
18E26	2	E075	JAMP WIRE
18E27	2	E100	JAMP WIRE
18E28	1	E150	JAMP WIRE
18E29	3	E175	JAMP WIRE

**OPERATION PCB ASSY**

REF. NO.	Q'TY	PART NO.	DESCRIPTION
<b>P.C. BOARD</b>			
19E1	1	OPE-K032A	PRINTED CIRCUIT BOARD
<b>SEMICONDUCTORS</b>			
Q701-703	3	1SS133	DIODE
LD701	1	LN342GP	LED
LD702,703	2	LN842RP(V)	LED
LD704-706	3	LN442YP	LED
LD707	1	LN342GP	LED
<b>CAPACITORS</b>			
C701	1	S5-6R3TW101M	ELECTROLYTIC CAPACITOR
<b>RESISTORS</b>			
R701	1	KA16ST221J	CARBON RESISTOR
R702-704	3	KA16ST151J	CARBON RESISTOR
<b>SWITCHES</b>			
S701	1	SKHHQV	TACT SWITCH
S702	1	SKHHPK	TACT SWITCH
S703,704	2	SKHHQV	TACT SWITCH
S705	1	SKHHPK	TACT SWITCH
S706-708	3	SKHHQV	TACT SWITCH
S709,710	2	SKHHPK	TACT SWITCH
S711-713	3	SKHHQV	TACT SWITCH
<b>MISCELLANEOUS</b>			
BK701	1	BX1387	REMOTE SIGNAL RECEIVING UNIT
MC701	1	MK-1LS075-K054	MICRO SOCKET ASS'Y
MC702	1	MK-1LS035-K055	MICRO SOCKET ASS'Y
MC703	1	MK-1LS095-K035	MICRO SOCKET ASS'Y
19E23	6	E050	JAMP WIRE
19E29	6	E100	JAMP WIRE
19E30	2	E150	JAMP WIRE

**VOLUME PCB ASSY**

REF. NO.	Q'TY	PART NO.	DESCRIPTION
<b>P.C. BOARD</b>			
20E1	1	VR-K032A	PRINTED CIRCUIT BOARD
<b>SEMICONDUCTORS</b>			
Q501,502	2	25C2878-A+B	TRANSISTOR
<b>RESISTORS</b>			
R501,502	2	KA16ST102J	CARBON RESISTOR
R503,504	2	KA16ST682J	CARBON RESISTOR
VR501	1	V8V16-503A20K4	ROTARY POTENTIOMETER
<b>MISCELLANEOUS</b>			
MC501	1	MT-22A07F-K067	MICRO SOCKET ASS'Y
20E10	1	E125	JAMP WIRE

**LED PCB ASSY**

REF. NO.	Q'TY	PART NO.	DESCRIPTION
<b>P.C. BOARD</b>			
20E12	1	LED-K032A	PRINTED CIRCUIT BOARD
<b>SEMICONDUCTORS</b>			
LD801	1	SL9406-20	LED
LD802,803	2	LN513RK5	LED
<b>RESISTORS</b>			
R801	1	KA16ST220J	CARBON RESISTOR
<b>MISCELLANEOUS</b>			
MC601	1	MC-172677-K039	MICRO SOCKET ASS'Y
MC802	1	MC-172677-K053	MICRO SOCKET ASS'Y

**POWER SUPPLY PCB ASSY**

REF. NO.	Q'TY	PART NO.	DESCRIPTION
<b>P.C. BOARD</b>			
21E1	1	PS-K036	PRINTED CIRCUIT BOARD
<b>CAPACITORS</b>			
C901	1	ECQU2A103MN	METALLIZED FILM CAPACITOR
<b>COILS</b>			
L901,902	2	180015	CHOKE
<b>SWITCHES</b>			
S901	1	ES88215V	POWER SWITCH
<b>MISCELLANEOUS</b>			
EL901,902	2	S9854795	GND LUG
EL903-905	3	S-001P	GND LUG
FU901	1	FU-524014ST	FUSE
21E14	2	23165102-88-C	FUSE HOLDER
21E17	1	820633	CAPACITOR BOOT
21E23	1	BK4123-401	LABEL FUSE

**OTHER PARTS**

REF. NO.	Q'TY	PART NO.	DESCRIPTION
<b>MISCELLANEOUS</b>			
J013	1	0075260804-C-C	SOLDER-PLATED WIRE
ZM28	2	VJR-3	SNAKE LUG
3M 2	6	BK4151	MASTER CARTON LABEL, SERIAL NO.
3M 3, M29, M30	6	N45335	
5M23	2	TPM-30X08-B	TAP SCREW P, ROUND HEAD, B
MC101	1	MZ-PHR09-K058	MICRO SOCKET ASS'Y
MC102	1	MZ-PHR06-K057	MICRO SOCKET ASS'Y
MC103	1	MK-1LS035-K075	MICRO SOCKET ASS'Y
MC104	1	MT-22A02F-K065	MICRO SOCKET ASS'Y
MC105	1	M84-02-3095A	MICRO SOCKET ASS'Y
MC202	1	MT-22A03F-K066	MICRO SOCKET ASS'Y

**Classify Parts List**

A : USA    B : U.K.    C : EUROPE & OTHERS    C2 : G.P.M.  
 A1 : CANADA    B1 : AUSTRALIA/N.Z.    C1 : W.GERMANY

Ref.No.	Description	A	A1	B	B1	C/C1	C2
<b>MAIN UNIT Section</b>							
1M18	REAR PANEL	BK2037	BK2037	BK2037-1	BK2037-1	BK2037-2	BK2037-2
3M10	CAUTION SHEET, POLARIZED PLUG	N44687	N44687	Nil	Nil	Nil	Nil
3M11	LABEL, FUSE	N44525	N44525	Nil	Nil	Nil	Nil
3M13	CONVERSION PLUG	Nil	Nil	Nil	Nil	Nil	S-16115#01
3M14	FDA LABEL LASER CAUTION	BK4082A	BK4082A	Nil	Nil	Nil	Nil
3M14-1	LABEL (LASER MARK)	Nil	Nil	N44838	N44838	N44838	N44838
3M15	CSA LABEL LASER CAUTION	BK4081A	BK4081A	Nil	Nil	Nil	Nil
3M15-1	LABEL (LASER CAUTION)	Nil	Nil	N44839	N44839	N44839	N44839
3M16	LABEL (CLASS 1 LASER PRODUCT)	Nil	Nil	N44837	N44837	N44837	N44837
3M18	TAG (AC CORD)	Nil	Nil	N41117	Nil	Nil	Nil
3M19	STICKER WARNING	Nil	Nil	N41994	Nil	Nil	Nil
3M21	POLYETHYLENE BAG (UNIT)	N41886-2	N41886-2	N41886-H-2	N41886-2	N41886-2	N41886-2
3M23	CARD, WARRANTY REGISTRATION	NAD-WC2A	Nil	Nil	Nil	Nil	Nil
3M25	LABEL, UL	N44934A	Nil	Nil	Nil	Nil	Nil
3M26	NON-WARRANTY CARD	Nil	LEN-200	Nil	Nil	Nil	Nil
3M26-1	SAFETY INSTRUCTION SHEET	BK3035	Nil	Nil	Nil	Nil	Nil
3M27	CARD, WARRANTY	Nil	LEN-201	Nil	Nil	Nil	Nil
3M28	LABEL, CSA COMPACT DISC	Nil	BK4142	Nil	Nil	Nil	Nil
△ 22E16	LINE CORD	ACC-033E3-4EC1	ACC-033E3-4EC1	ACC-013D3-4EC4	ACC-030D3-4EC1	ACC-005D3-4EC1	ACC-005D3-4EC1
22E19	CORD STOPPER	SR-4N-4	SR-4N-4	SR-5N-4	SR-4N-4	SR-4N-4	SR-4N-4
△ PT001	POWER TRANSFORMER	NPT-K0104	NPT-K0104	NPT-K0105	NPT-K0105	NPT-K0105	NPT-K0105
<b>POWER SUPPLY PCB Section</b>							
△ C901	METALLIZED FILM CAPACITOR	ECQU2A103MN	ECQU2A103MN	ECQU2A103MF	ECQU2A103MF	ECQU2A103MF	ECQU2A103MF
△ FU901	FUSE	FU-524014ST	FU-524014ST	FU-522017T	FU-522017T	FU-522017T	FU-522017T
TU013,014	UL TYPE TUBE	Nil	Nil	U9-#01B02	U9-#01B02	U9-#01B02	U9-#01B02
△ 21E17	CAPACITOR BOOT	820633	820633	821033	821033	821033	821033
△ 21E23	LABEL FUSE	BK4123-401	BK4123-401	Nil	Nil	Nil	Nil

**Capacitors Description**

Type	Voltage	Value	Tolerance
<b>• Electrolytic</b>			
NS-10TW470M	10V	470µF	M
<b>• Mylar - Styrol</b>			
MY-50V S472 J	50V	472µF	J
<b>• Ceramic</b>			
HE 90 SJ YF 223 Z	90V	223µF	Z
CC 45 SL 1H 470 K	45V	470µF	K
CK 45 B 1H 103 K	45V	103µF	K
<b>• Electrolytic</b>			
Type	Voltage	Value	Tolerance
LL: Low Leak	-10: 10V	R47: 0.47µF	K: ±10%
NP: Non-Pole	-50: 50V	4R7: 4.7µF	M: ±20%
NS: Standard	6R3: 6.3V	470: 470µF	
		471: 470µF	
		472: 4700µF	
		473: 0.047µF	
		474: 0.47µF	
		(1000µF=0.001µF)	
<b>• Mylar - Styrol</b>			
Type	Voltage	Value	Tolerance
MY: Mylar	-25V: 25V	4R7: 4.7pF	G: ±2%
ST: Styrol	125V: 125V	470: 47pF	J: ±5%
	-63T: 63V	471: 470pF	K: ±10%
		472: 4700pF	M: ±20%
		473: 0.047µF	
		474: 0.47µF	
		(1000pF=0.001µF)	
<b>• Ceramic</b>			
Type	Voltage	Value	Tolerance
HC: 25V	1E: 25V	4R7: 4.7pF	C: ±0.25pF
HE: 50V	1H: 50V	470: 47pF	D: ±0.5pF
H: 100V	2H: 500V	471: 470pF	F: ±1pF
HK: 250V		472: 4700pF	J: ±5%
HM: 500V		473: 0.047µF	K: ±10%
		474: 0.47µF	M: ±20%
		(1000pF=0.001µF)	Z: +80~-20%

**Resistors Description**

Type	Wattage	Value	Tolerance	Diameter
<b>• Fixed</b>				
KA 25S T 473 J	25W	473Ω	J	
<b>• Semi-Variable</b>				
SVR-06S3B 103	6W	103Ω	B	10φ
CE: Cement Case	-2W: 2W	R47: 0.47Ω	M: ±20%	8φ
FR: Flame Proof	10W: 10W	4R7: 4.7Ω	K: ±10%	10φ
KA: Carbon	16S: 16W	470: 47Ω	J: ±5%	06: 6φ
MF: Metal Film	20S: 15W	471: 470Ω	G: ±2%	
RF: Fusible	25S: 14W	472: 4.7kΩ	F: ±1%	
SA: Metal Oxide	50S: 12W	473: 47kΩ	D: ±0.5%	
	50X: 12W	474: 470kΩ		
	S3W: 3W	475: 4.7MΩ		

# SCHEMATIC DIAGRAM

## 5100 SCHEMATIC DIAGRAM

**WARNING:**  
Parts marked with the symbol  $\Delta$  have critical characteristics.  
Use ONLY replacement parts recommended by the manufacturer.

**CAUTION:**  
Before returning the unit to the customer, make sure you make either (1) a leakage current check or (2) a line to chassis resistance check. If the leakage current exceeds 0.5 millamp, or if the resistance from chassis to either side of the power cord is less than 500 k ohms the unit is defective.  
WARNING - DO NOT return the unit to the customer until the problem is located and corrected.

**CAUTION:**  
THOSE FUSES WITH SYMBOL MARKS  $\Delta$  ARE FAST BLOW TYPE. REPLACE WITH SAME TYPE 400 MA 250 V FUSE.

**ATTENTION:**  
LES FUSIBLES MARQUÉS  $\Delta$  SONT DE TYPE A FUSION RAPIDE. UTILISER UN FUSIBLE DE RECHANGE DE TYPE DE 400 mA 250 V.

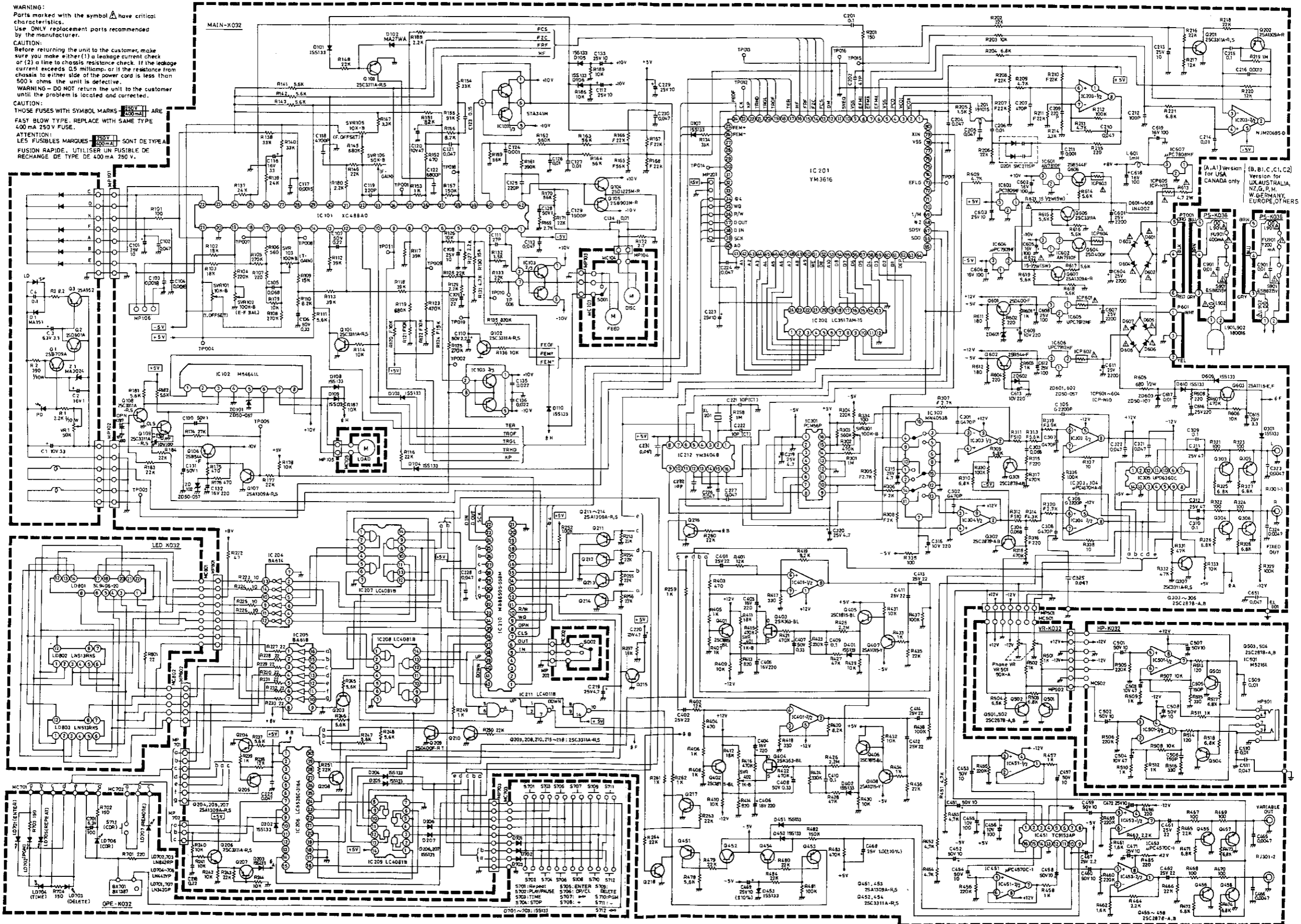



## THE DIFFERENCE OF PICK-UP HEAD

This model is in use the pick-up head of either Part No. is MLP-10 or MLP-10F2. In the case that you exchange the pick-up head with new one for the replacement, please use MLP-10F2 instead of MLP-10. With this modification, the values of some electrical parts and etc. shall be required to be changed.

After read **Cautions on Replacement of Pick-up** on page 4, you shall be exchanged the pick-up head.

1. Please exchange of parts refer to the below table and figure.

- Delete resistor R189.
- Exchange resistor R190 for the jump wire and short-circuit.
- The other parts exchange Part No. column A for B according as the below table.

A: Serial No.80400038~ 80400512 (Except Serial No.80400139 and 80400472)  
 B: Serial No.80400513~ (Include Serial No.80400139 and 80400472)

Ref. No.	Description	Part No.	
		A	B
—	PICK UP HEAD	MLP-10	MLP-10F2
D102	DIODE	1SS133	MA27WA
C103,104	MYLAR CAPACITOR	MY-50VS222J	MY-50VS182J
R109	CARBON RESISTOR	KA16ST103J	KA16ST153J
R119	CARBON RESISTOR	KA16ST394J	KA16ST684J
R123	CARBON RESISTOR	KA16ST184J	KA16ST474J
R124	METAL FILM RESISTOR	MF16ST203F	MF16ST153F
R125	CARBON RESISTOR	KA16ST124J	KA16ST274J
R128	CARBON RESISTOR	KA16ST103J	KA16ST223J
R133	CARBON RESISTOR	KA16ST103J	KA16ST223J
R151	CARBON RESISTOR	KA16ST104J	KA16ST823J
R189	CARBON RESISTOR	KA16ST181J	Nil
R190	CARBON RESISTOR	KA16ST1R0J	Short

MAIN PCB ASSY

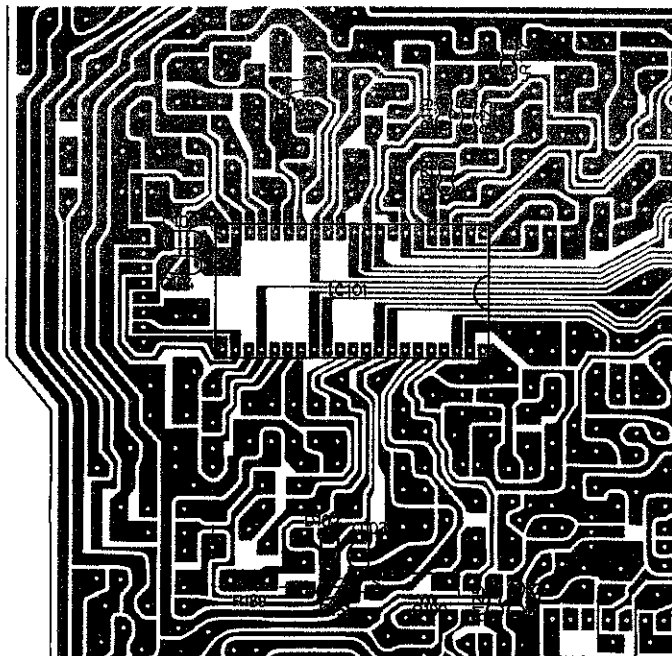

2. The difference of Adjustment value (Tracking Gain) refers to the following.

Pick-up head : MLP-10

Rating : ETE = (EQ +15 dB) ±3 dB

Pick-up head : MLP-10F2

Rating : ETE = (EQ +11 dB) ±3 dB

# SERVICE MANUAL

SM-K040 8808  
© 1987 BY NAD PRINTED IN JAPAN

**5100**  
COMPACT DISC PLAYER

**NAD ELECTRONICS**  
BOSTON/LONDON