

**SERVICE
MANUAL**

4225
STEREO TUNER

ALIGNMENT METHOD

FM ALIGNMENTS

NECESSARY INSTRUMENTATION

FM GENERATOR (less THAN 0.05% thd)

STEREO GENERATOR (less than 0.05% THD, more than 50 dB separation at 1 KHz.)

AUDIO GENERATOR (not necessary if FM generator has built in sweep; i.e. SOUND TECHNOLOGY ST 1000A and ST 1020A).

2 AC VTVM's (or one with left/right channel switch)

THD ANALYZER (resolution better than 0.1%)

OSCILLOSCOPE (5mV or better sensitivity, X input capability)

FREQUENCY COUNTER

VOM or DMM (high impedance, must read in mV)

DIODE DETECTOR PROBE

COPPER/FERRITE INDUCTOR

IMPORTANT: While all FM generator output levels hereafter are referred to the 300 ohm input, 75 ohm input can be used, but be aware of possible equipment groundloops and divide the RF output level by 2. Before alignments commence set input selector to tuner and release tape, mono and FM NR. defeat switches (out) ALIGNMENT OF FRONTEND should only be necessary after repair to frontend or drystal oscillator circuits (pin 2 and 3 on Q911).

A TUNING VOLTAGE (OSCILLATOR)

It is essential to check tuning voltage before aligning the rest of the frontend.

1. Connect DMM between shield and Pin 5 on frontend.
2. Tune to 108 MHz and adjust L8 if voltage is incorrect.
SPECIFICATION 20.5V \pm 0.5V
3. Tune to 87.5 MHz and read voltage, repeat step 2 and 3 if incorrect.
SPECIFICATION 3V \pm 0.5V

B RF ADJUSTMENT (TRACKING)

1. Connect RF generator to antenna input and detector probe to pin 1, Q104 (IF DETECTOR). with ground to detector shield. Adjust sensitivity of oscilloscope to maximum (5mV or better) and modulate FM generator sweep \pm 300 KHz or more with modulating (sweep) signal connected to X-input of oscilloscope.
2. Set tuner to 90 MHz, enter into preset 1, and tune generator so that curve appears on oscilloscope. Turn down RF input level so that curve covers approximately 1/2 of oscilloscope display.
3. Check alignments of L2-L4-L5 by inserting copper/ferrite inductor close to them while watching curve on oscilloscope. Curve should decrease in height with either ferrite (same as increasing inductance, i.e. more core) or with copper (same as decreasing inductance, i.e. extend size of coil). If curve increases in size more than 10%, adjust only the coil which reacts incorrectly. Adjust coils by gently extend or contract the aircoil with a non-metallic and non-static tool (i.e. plastic knit-pin or a wooden stick). Be careful not to deform coil.
4. Set tuner to 105 MHz, enter into preset 2, and tune generator so that curve appears on oscilloscope.
5. Check L2-L4-L5 again with the ferrite/copper inductor, Curve should not increase more than 10% on any of the coils.

6. Repeat step 2+3+4+5 if curve height is outside of tolerances, if necessary distribute the error between 90 and 105 MHz. Check tuning voltage again if tolerances not possible to achieve.

C IF ADJUSTMENT

1. Set tuner to approximately 98 MHz (the tuner must be tuned to an unoccupied frequency) enter into preset 3, and tune FM generator to display a curve on the oscilloscope.
2. Adjust I 1 (IFT tuner frontend) to maximum and symmetrical curve on the display, using as little input signal as possible.

D DETECTOR COARSE ADJUSTMENT (OPTIONAL, NEEDED ONLY IF DETECTOR WAS REPAIRED).

1. Reduce sweep modulation level to ± 75 KHz and set input level to 300 μ V.
 2. Adjust FM generator frequency so that both legs of the inverted U-shaped curve are equally high on the display. The curve should be almost perfectly symmetrical.
 3. Disconnect detector probe from tuner and oscilloscope. Connect either of the tape rec. outputs to the oscilloscope.
 4. Adjust I102, FM DET PRIMARY to maximum curve height and I103, FM DET the front of unit to minimum curve height and straightest possible line.
Go back and forth between primary and secondary till both are peaked.
- NOTE: Both the cores should be within 1.5mm from the top of the form.

E DETECTOR ALIGNMENTS (FINAL)

1. Disconnect detector probe and connect tape rec. outputs to VTVM's oscilloscope and distortion analyzer.
2. Switch stereo generator to 1 KHz 100 % (± 75 KHz) mono modulation and oscilloscope to normal internal sweep 0.2 mS and 0.5 V/cm sensitivity.
3. Detector reference frequency Reduce FM generator output level while monitoring THD from left channel. When THD increases to 3%, fine tune the FM generator frequency to minimum THD. Reduce FM generator output level and fine tune till no reduction in the 3% THD can be achieved by fine tuning. Use this frequency for all the following detector, MPX adjustments.

NOTE: The typical input level for this 3% THD should be 1.6 μ V to 2.3 μ V.

This is done only to "lineup" the frequency from the generator to the tuner's frequency. IF IHF usable sensitivity (-30 dB THD+N=3.16% THD+N) is to be verified, a proper IHF bandpassfilter must be used.

4. Connect DMM across P112 (negative) and P113 (positive). Set FM generator output level to 1000 μ V.
5. Adjust I102, FM DET PRIMARY for OV on DMM
TOLERANCE ± 50 mV
6. Adjust I103, FM DET SECONDARY for lowest THD
SPECIFICATION less than 0.1%.
7. Adjust C917 for lowest THD.
8. Repeat steps 5-7 till no further improvements. Record the DMM's final reading for use later in the adjustment.

F AUTOSEARCH LEVEL

1. Connect DMM between P120 and ground.
2. Set FM generator level to 10 μ V and adjust R117 so that DMM reading goes from 8.5V to approximately 0.55V at 10 μ V.
TOLERANCE ± 0.1 V.

G. STEREO DECODER, MPX FILTERS.

1. Stereo separation. Set FM generator output to 1000 uV.
2. Modulate FM generator left channel only and adjust R127 for minimum on right channel VTVM.
3. Modulate FM generator right channel only and adjust R127 for minimum on left channel VTVM.
4. If the minimum in step 9 and 10 are different, adjust R127 so that the readings are the same in both channels.
5. MPX filter
Turn off audiomodulation, leaving pilot tone only. Disable IHF filter or external 19 KHz filter if used. Adjust left channel and right channel for minimum output.

SPECIFICATION more than 60 dB suppression.

AM ALIGNMENTS

Unless repairs have been done to Oscillator Section, do not adjust AM OSC coil or Trimming Capacitor.

If OSC Adjustment is needed, connect high impedance voltmeter (preferably DMM) between P14 and ground.

A. OSC ADJUSTMENT

1. Tune unit to show 600 KHz on display and adjust L102 to read $1.75V \pm 0.05V$ on DMM. Adjust L101 for maximum output.
2. Tune unit to show 1400 KHz on display and adjust L101 for maximum output.
3. Repeat step 1 and 2 until no further improvement.

B. IF ADJUSTMENT

1. For IF adjustment and Tracking adjustment connect VTVM to loudspeaker output (or tape output), only one channel connection needed, and connect signal generator to antenna terminals. Adjust generator for 30% modulation and approx. 10 uV input (DIRECT). Tune both generator and receiver to approx. 100 KHz, and adjust generator frequency for maximum reading on VTVM. Then adjust I101 for maximum reading on meter.

C. TRACKING ADJUSTMENT

1. Tune unit and generator to show approx. 600KHz and adjust L101 to maximum reading on VTVM.
2. Tune unit and generator to show approx. 1400KHz and adjust C138 (Trimming Capacitor) for maximum reading on VTVM.
3. Repeat step 1 and 2 until no further improvement.

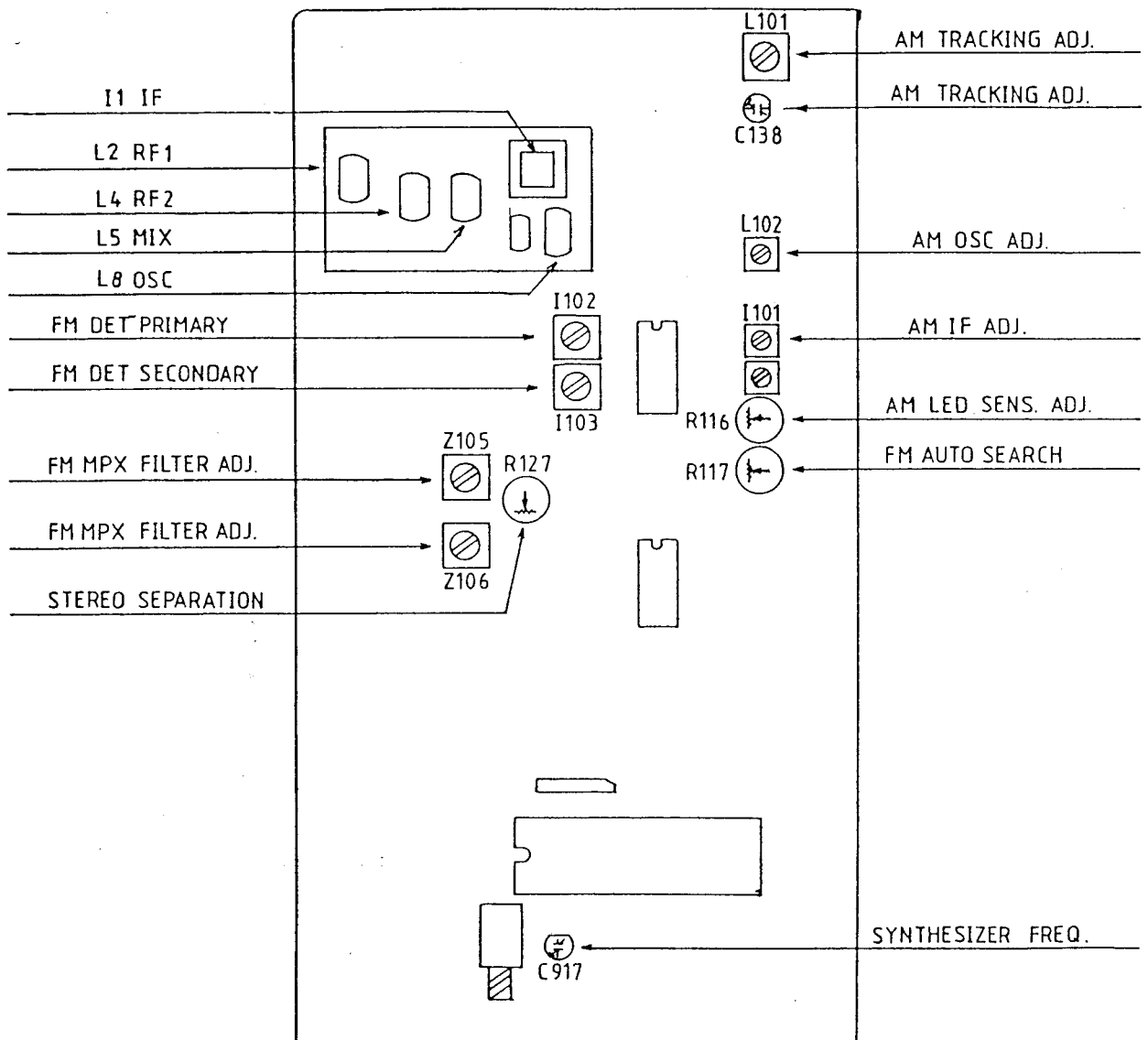

ALIGNMENT METHOD

110 7511 220 J 513
 7512

NAD 4225 PCB LAYOUT AND WIRING DIAGRAM

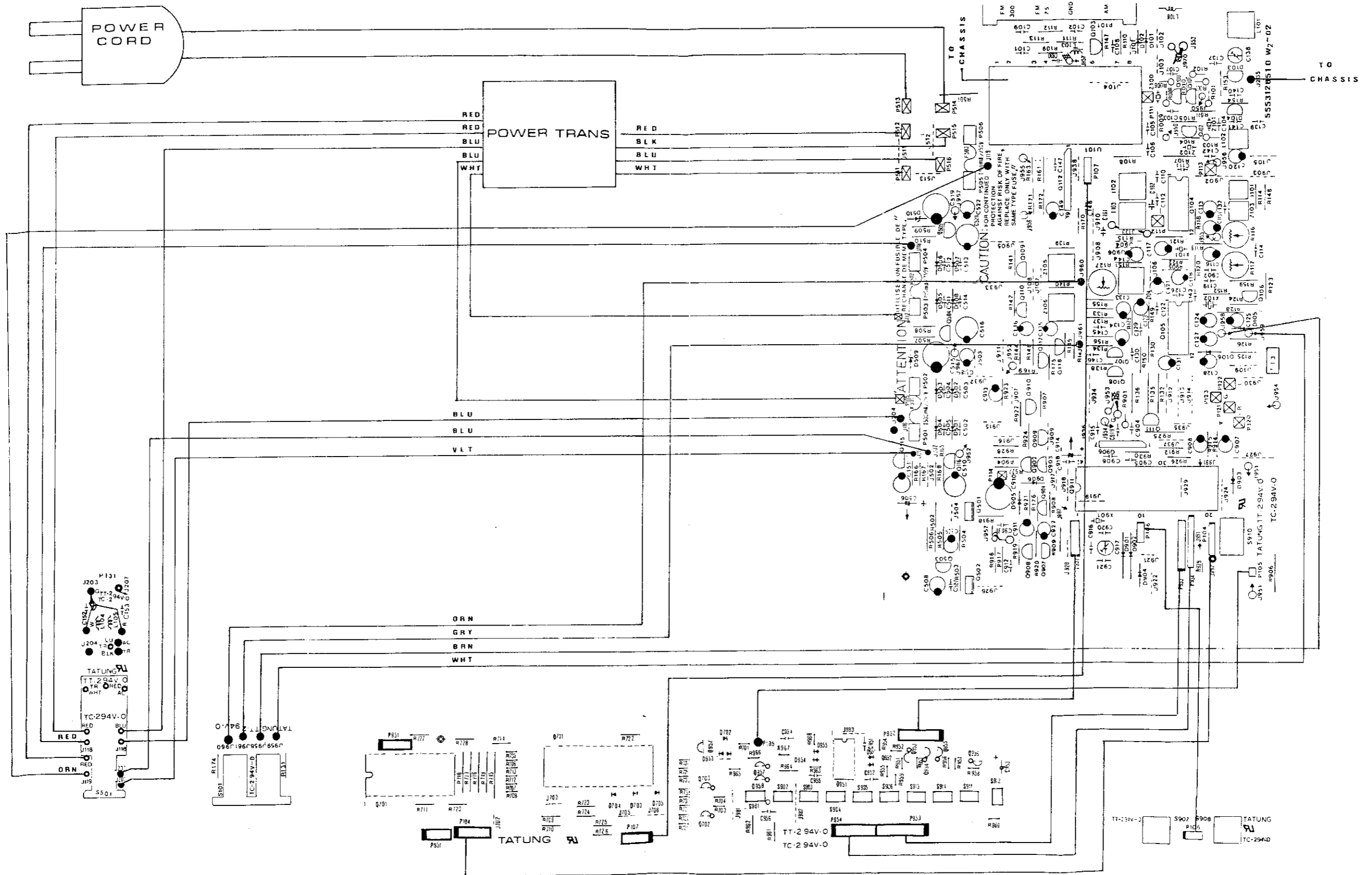

NAD 4225 PCB LAYOUT

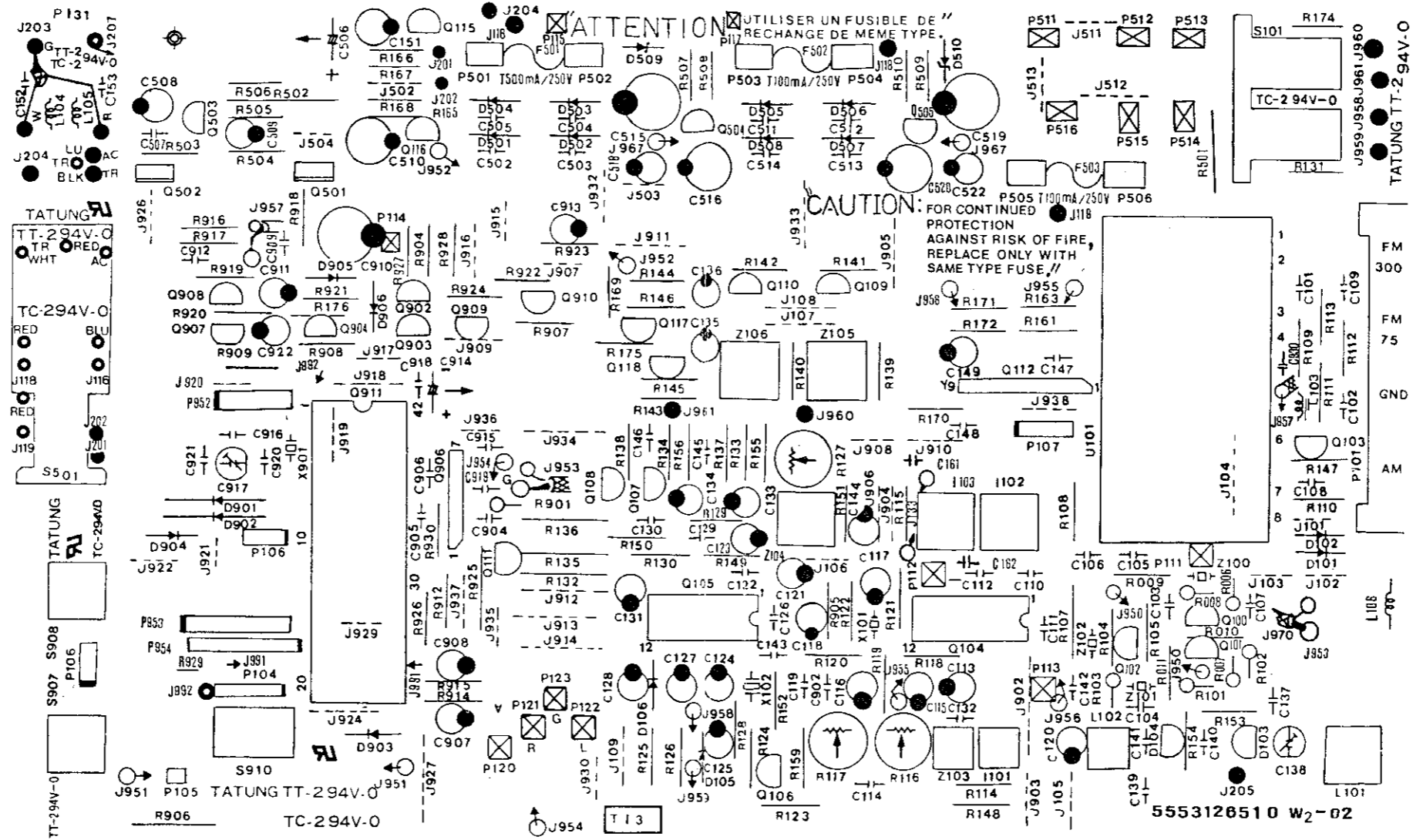

DISPLAY/CONTROL PCB COMPONENT LOCATION

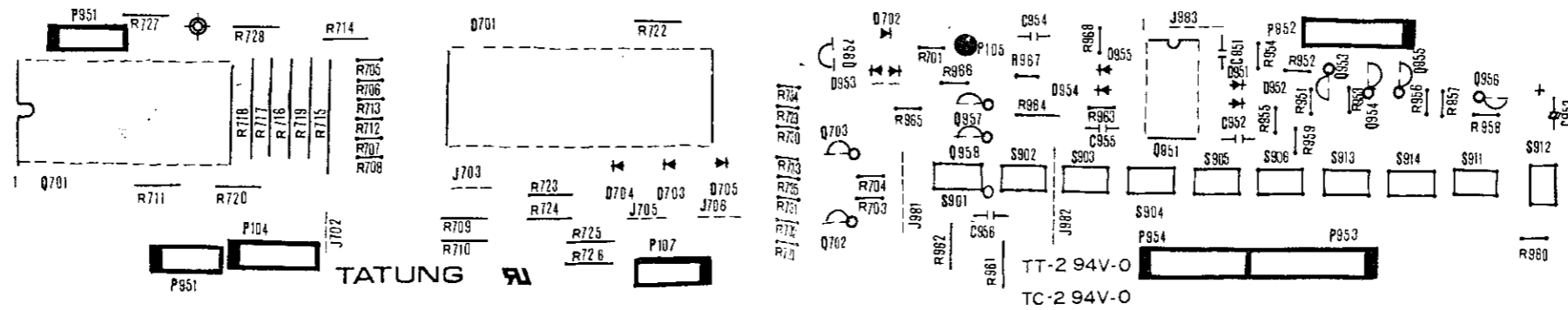

NAD 4225 SCHEMATIC DIAGRAM

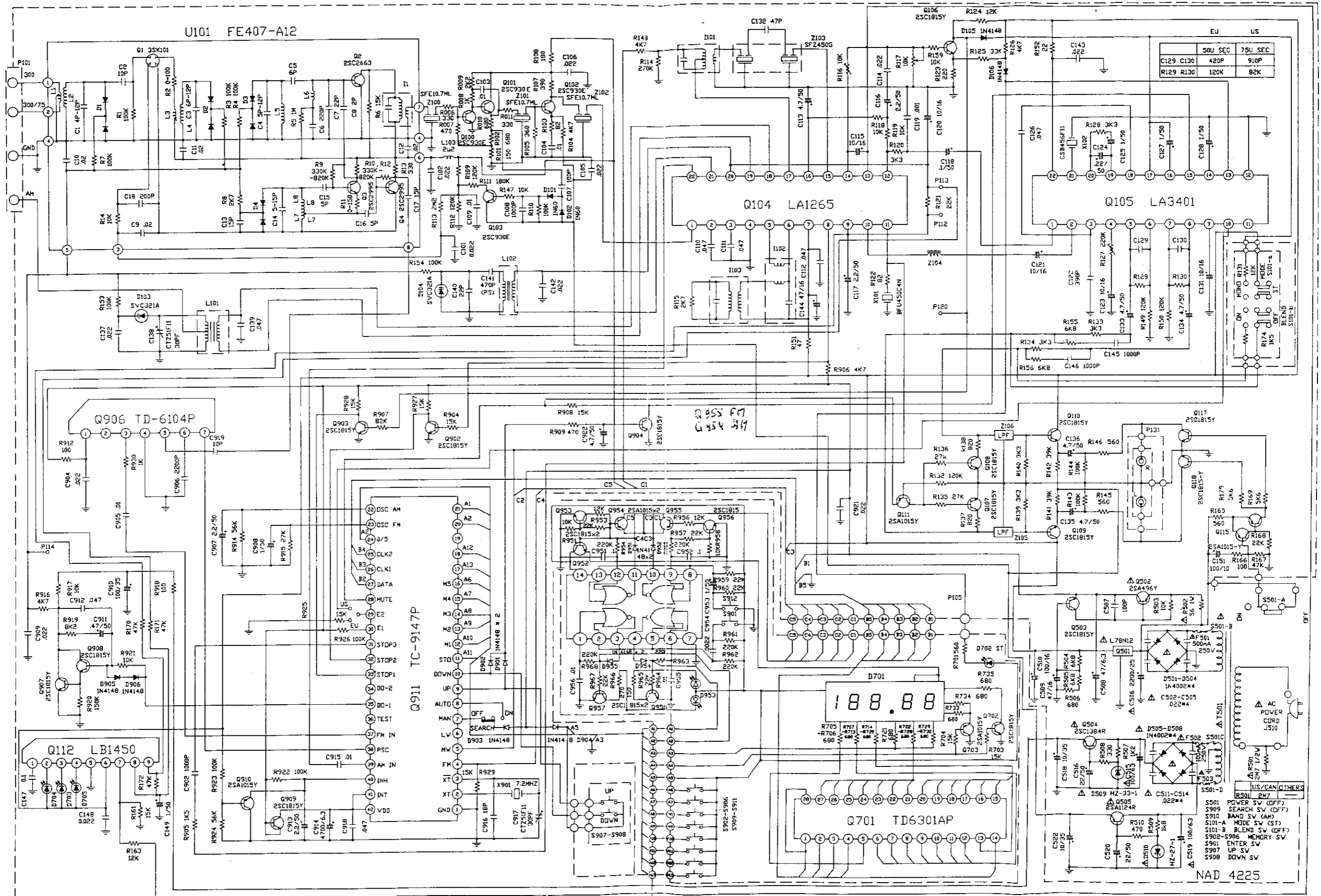

EU		US	
50U SEC	75U SEC	50U SEC	75U SEC
C129	C130	420P	910P
R129	R130	120K	82K

Q955 FM
Q954 AM

188.88

NAD 4225