

SERVICE

NAD 4020A AM/FM STEREO TUNER

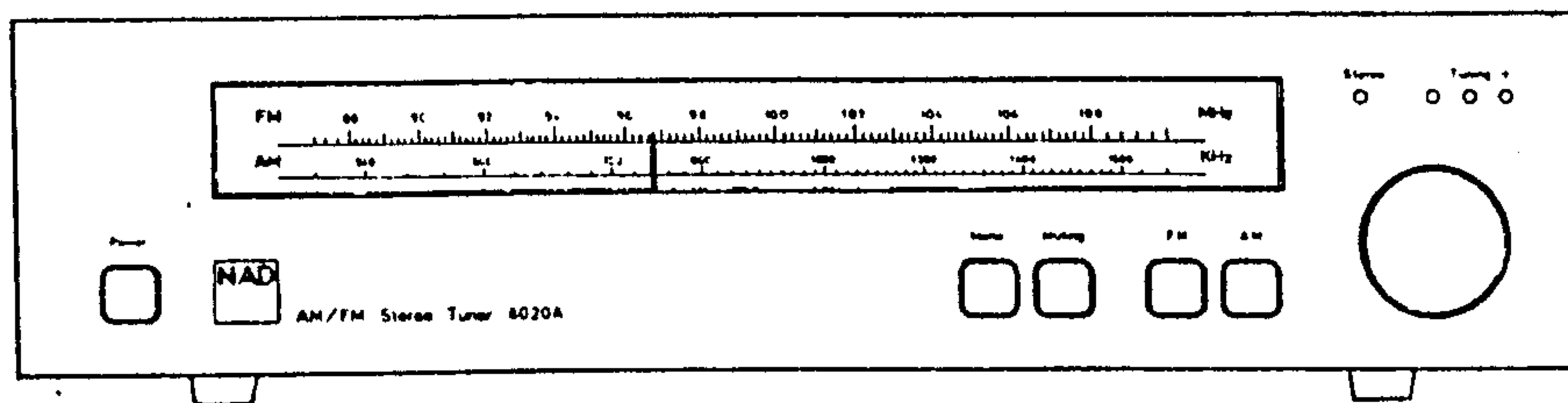

CIRCUIT DIAGRAM (NEW VERSION)

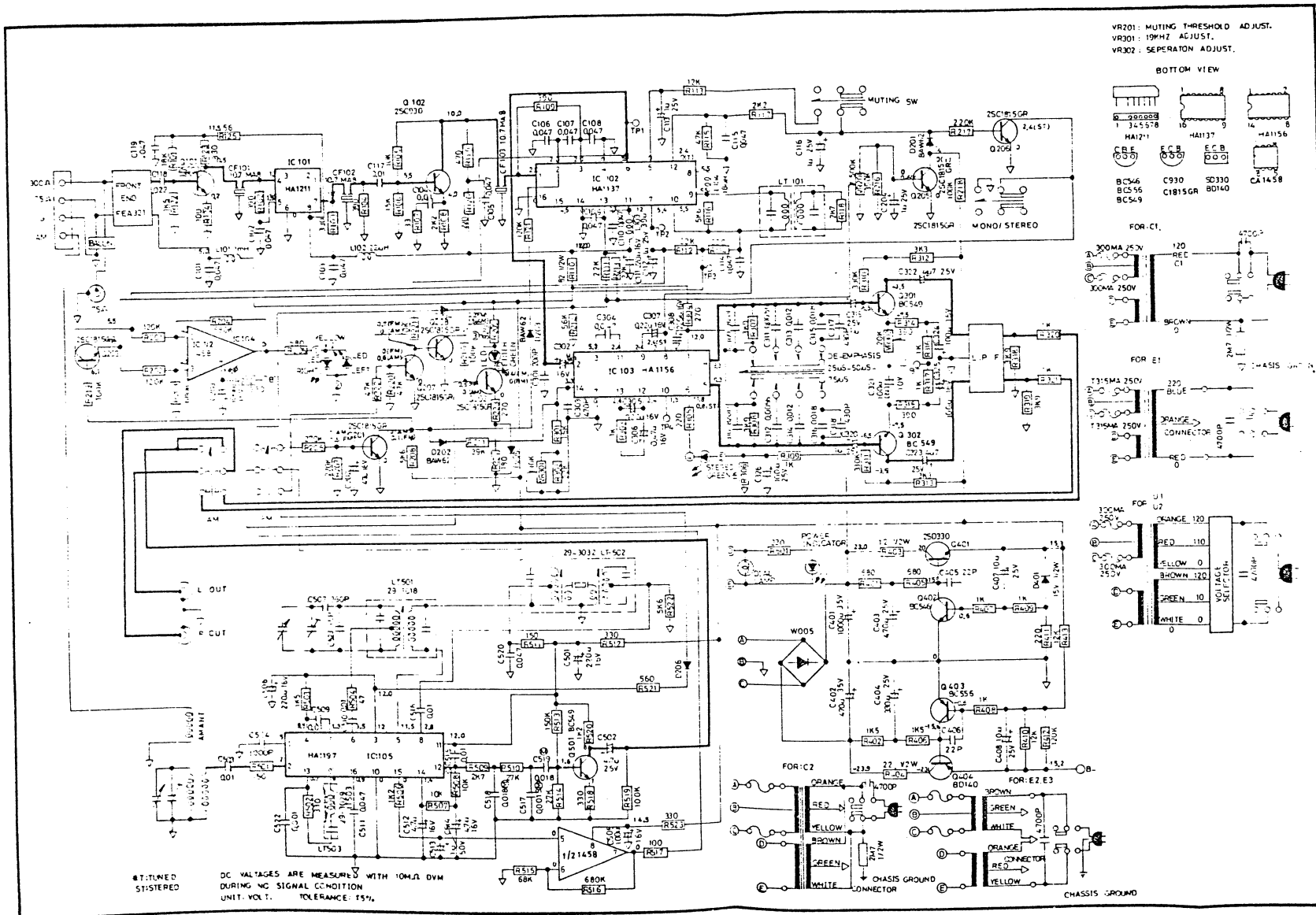

CIRCUIT DIAGRAM (OLD VERSION)

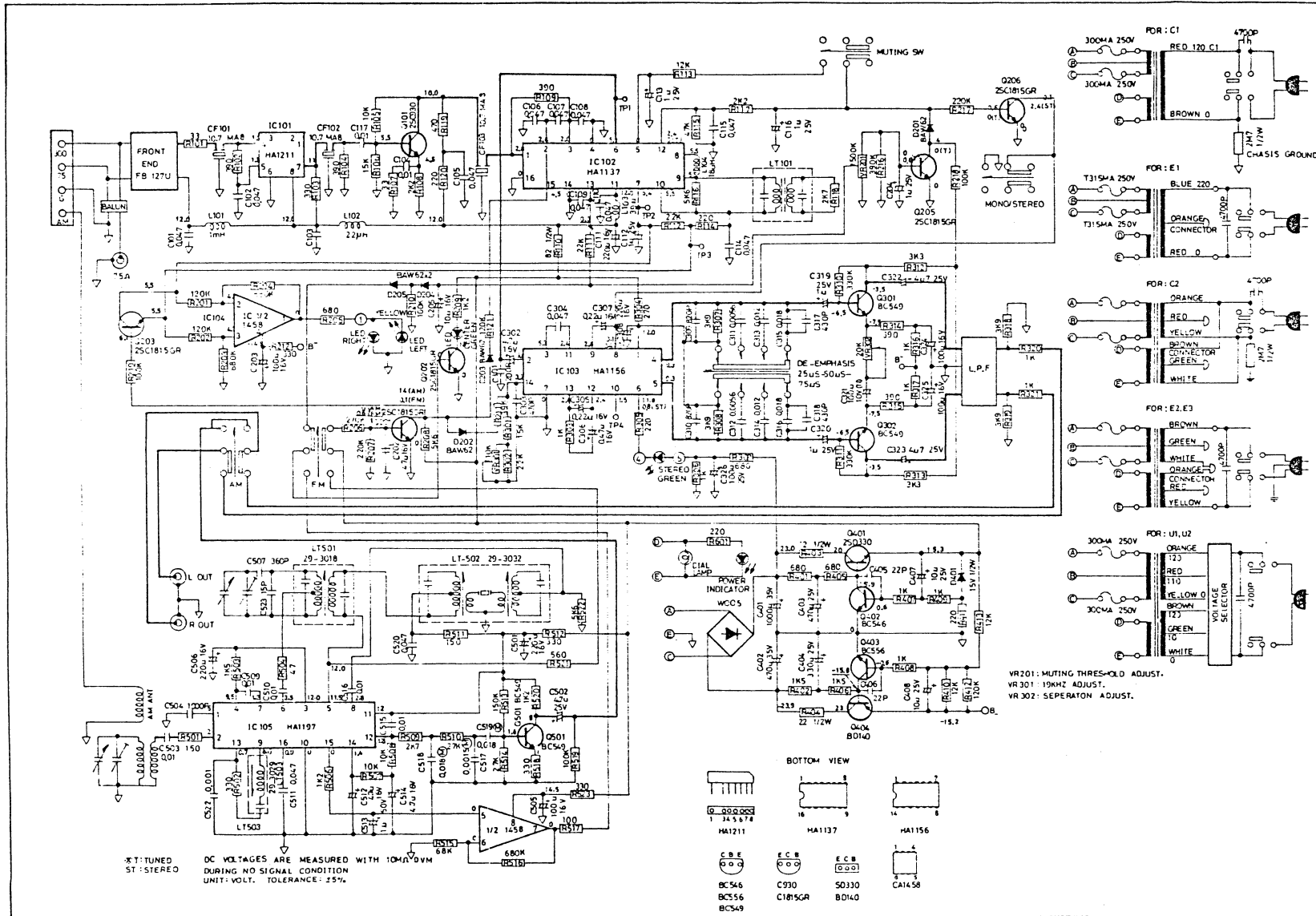

ALIGNMENT

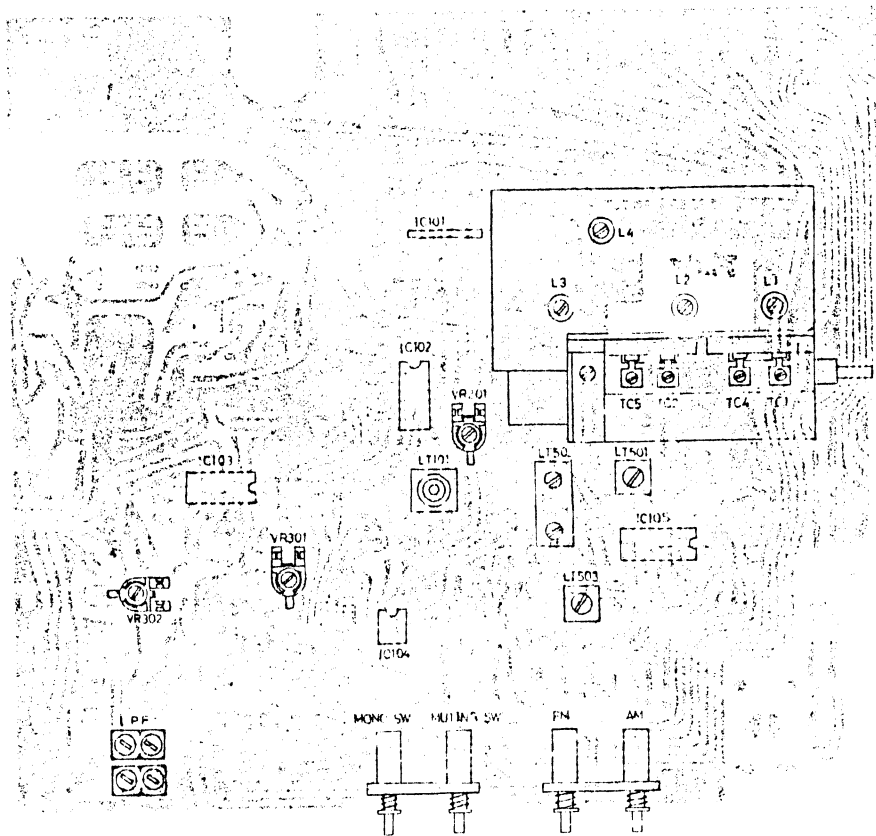
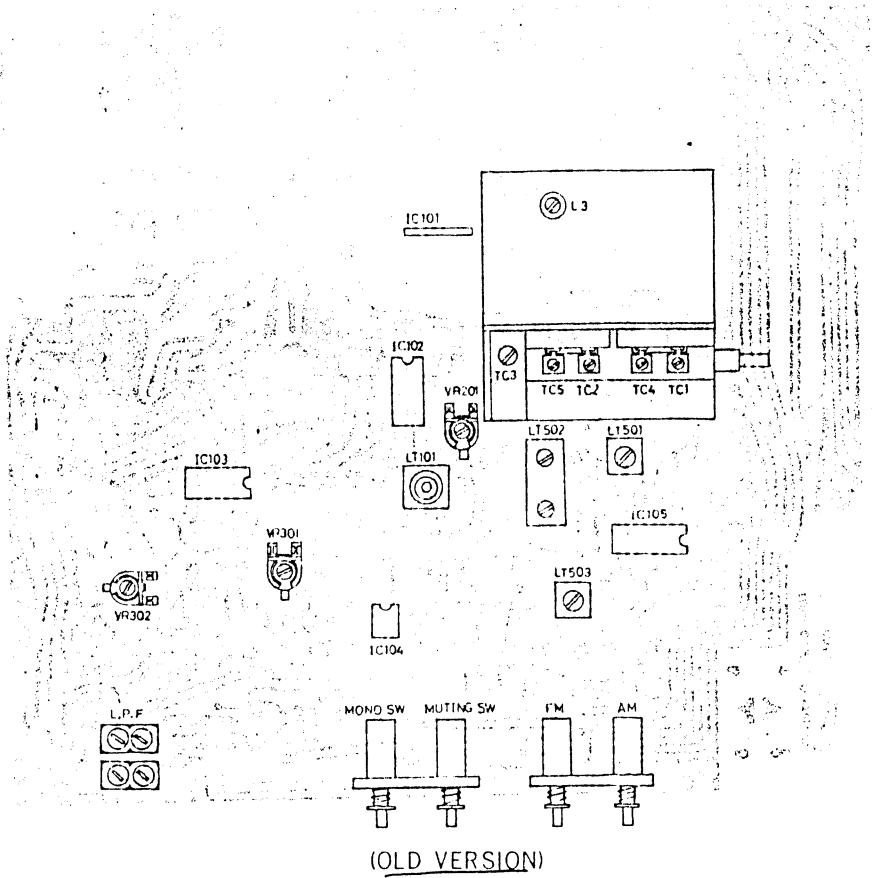

1. AM ALIGNMENT: 1. Selector switch in AM position 2. AC line voltage at rated voltage 3. Monitor output at RECORD OUTPUT								
Section	AM SG			Dial setting	Indicator	Adjustment point	Adjust for	
	Connection		Carrier Freq.					Modulation
AM IF	Hot side of SG output through 200PF to AM antenna trimmer terminal		455KHZ	30% Mod 400Hz	point of non-interference	VTVM or Oscilloscope	LT503 LT502	Maximum Output
AM RF	1	Hot side of SG output through 200PF to EXT AM antenna terminal on rear panel.	600KHZ	30% Mod 400Hz	600KHz	V.T.V.M or Oscilloscope	LT501	Maximum Output
	2		1400KHZ	30% Mod. 400Hz	1400KHz		TC2 TC4	
	3		Repeat Step 1 and Step 2					
2 FM ALIGNMENT: 1. Selector switch in FM position 2 AC line voltage at rated voltage 3 Monitor output at RECORD OUTPUT								
Section	FM SG			Dial setting	Indicator	Adjustment point	Adjust for	
	Connection		Carrier Freq.					Modulation
FM IF	_____		_____	_____	Point of NON-interference	Tuning LED of set	L1101 Lower side	Center Indication
FM RF	1	Connect to FM 300 ohm antenna terminal on the rear panel through FM dummy antenna	90MHz	100% Mod 400Hz	90MHz	V.T.V.M or Oscilloscope	LO-1 IFT-1	Maximum Output
	2		106MHz		106MHz		TC1 TC3 TC5	
	3		Repeat Step 1 and Step 2					
FM mono distortion	1		98MHz	100% Mod. 400Hz	98MHz	Distortion Meter	LT101 Upper side	Minimum Distortion
	2		Repeat FM IF and FM Mono Distortion step 1					
FM mute	1		Muting push Switch ON Adjust attenuator of FM SG for antenna input 14dB					_____
	2		98MHz	100% Mod. 400Hz	98MHz	VTVM or Oscilloscope	VR201	Output just disappear
	3		Increase FM SG output 4dB more to get full audio output					_____
	4		If full audio output cannot be got, repeat step 2, 3					_____
3 FM MPX ALIGNMENT: 1. Same as FM ALIGNMENT 1, 2, 3 2 FM SG is external modulated by stereo SG and connected to FM 300[] antenna terminal on the rear panel through FM dummy antenna								
Section	Step	FM SG	Stereo SG	Dial Setting	Indicator	Adjustment	Adjust for	
MPX Pilot	1	_____	_____	Point of no signal received	Connect frequency counter through 100 [] to TP4	VR301	19 KHz ± 30 Hz	
	2	98MHz	10% 19KHz pilot 90% L+R, L-R	98MHz	_____	VR301	Stereo LED light	
Separation	1	98MHz	10% 19KHz pilot L only	98MHz	Connect VTVM or Oscilloscope to R REC out	VR302	Maximum Output	
	2		10% 19KHz pilot R only	98MHz	Connect VTVM or Oscilloscope to L REC out	VR302		
	3		Repeat Step 1 and Step 2					
	4		If there is an excessive difference between leak-free effect of both channels, slightly adjust VR302 so that the levels of signal leakage of both channels are equal					