

NAD **SERVICE**
MANUAL

MONITOR SERIES

2400

POWER AMPLIFIER

NAD 2400 SERVICE MANUAL

CONTENTS

2. Safety Notice
3. Rear/Front View
4. Specifications
6. Main Amplifier Alignment
7. Schematics, Foil Diagram
11. Wiring Diagram
13. Exploded View
14. Exploded View Parts List
17. Electrical Parts List

Version	Voltage	Country
A	120	USA
A1	120	Canada
B	240	UK
B1	240	Australia
C	220	Europe, others
C1	220	W. Germany
C/S	220	Scandinavia

SERVICE SAFETY PRECAUTIONS (UL)

1. Use exact replacement parts for critical locations, marked "Δ" on parts list.
2. Return lead dress to original position, and re-install protective covers.
3. Before returning to customer, test for shock hazard; use either method A or B:
 - A. Leakage test, "cold":
 1. Unplug AC cord, turn power switch ON.
 2. Connect one lead of High Voltage Insulation Tester to both prongs of AC plug.
 3. Touch other lead to all exposed metal parts.
 4. Impedance measurement must be 0.3 - 5.0 Megohms.
 - B. Leakage test, "live":
 1. Plug unit directly into AC outlet; do not use isolation transformer.
 2. Connect one lead of Leakage Current Tester to earth ground.
 3. Touch other lead to all exposed metal parts.
 4. Leakage measurement must be less than 0.5 milliamps.

ATTENTION:
 ET LES COMMERCIANTS
 GÉNÉRALISTES
 EN RÉPARATION
 PASSEZ-VOUS
 ET DE TOUCHER AUX
 COMPOSANTS ÉLECTRIQUES
 SAUF LA PRÉSENCE D'UNE
 PERSONNE QUALIFIÉE

CAUTION
 TO PREVENT
 THE RISK OF ELECTRIC
 SHOCK, DO NOT REMOVE
 COVER OR BACK
 NO USER SERVICEABLE
 PARTS INSIDE. REFER
 SERVICING TO QUALIFIED
 SERVICE PERSONNEL

REAR PANEL CONNECTIONS

1. AC LINE CORD.
2. AC OUTLETS.
3. SPEAKERS A.
4. SPEAKERS B.
5. INPUTS.
6. NORMAL/LAB SELECTOR.
7. SOFT CLIPPING.
8. BRIDGING.
9. SPEAKER IMPEDANCE.

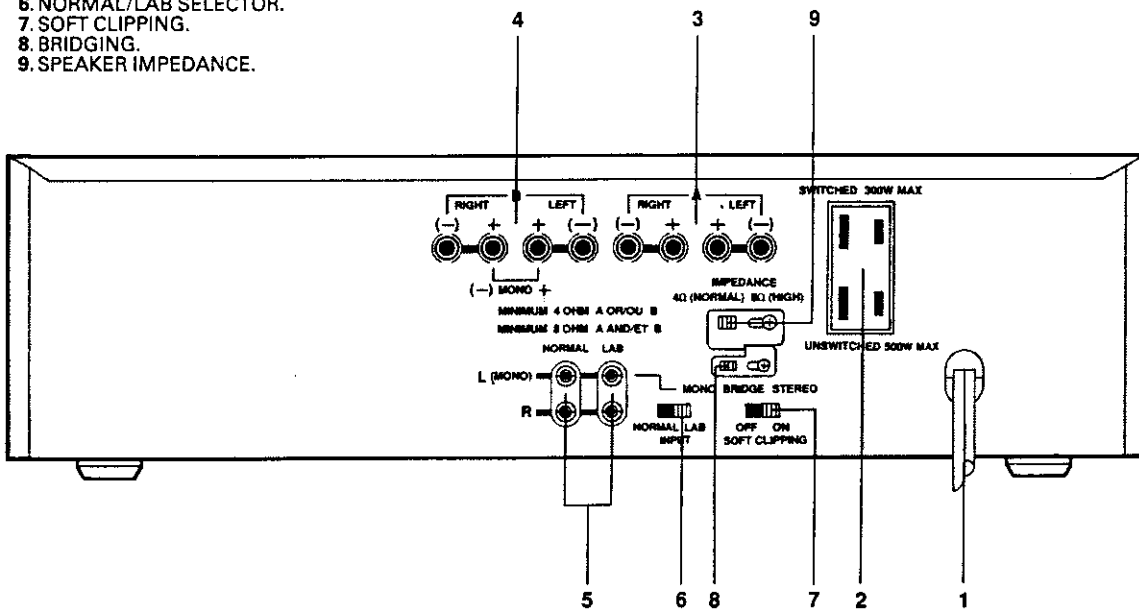

The lightning flash with arrowhead, within an equilateral triangle, is intended to alert the user of the presence of uninsulated "dangerous voltage" within the product's enclosure: that may be of sufficient magnitude to constitute a risk of electric shock to persons.

The exclamation point within an equilateral triangle is intended to alert the user of the presence of important operating and maintenance (servicing) instructions in the literature accompanying the appliance.

FRONT PANEL CONTROLS

1. POWER.
2. SPEAKERS A/B.
3. INPUT LEVEL.
4. STATUS INDICATORS.

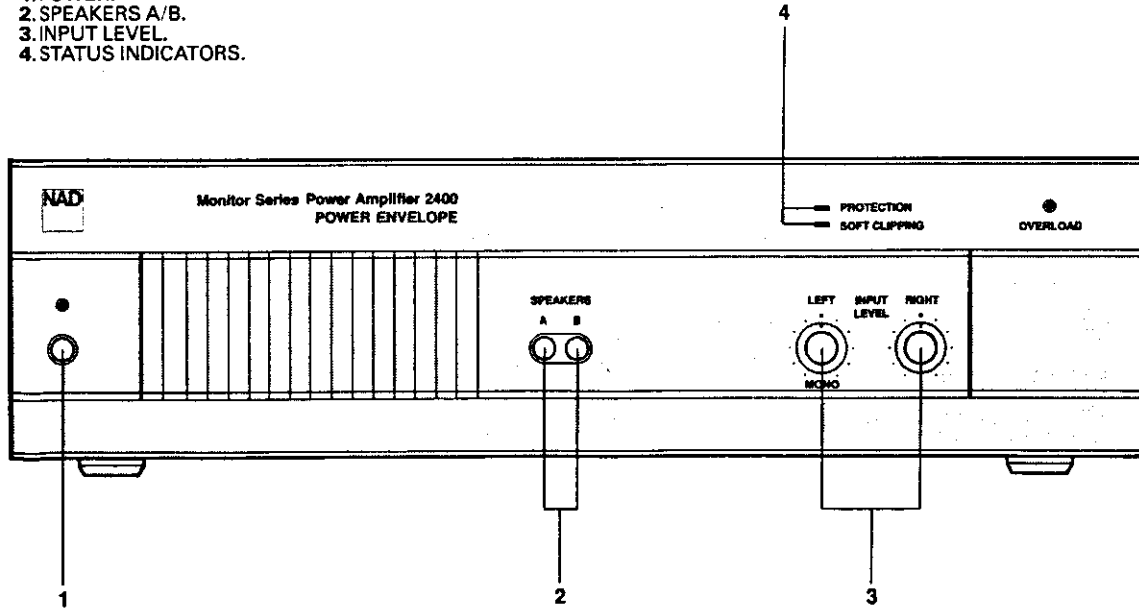

SPECIFICATIONS

Measured in accordance with EIA Standard RS-490 (IHF A-202). Measurements referenced to 8 ohms are taken with the Speaker Impedance selector set at 8Ω (High). Measurements for 4 and 2 ohms are taken with the Impedance Selector set at 4Ω (Normal).

STEREO MODE

CONTINUOUS AVERAGE POWER OUTPUT INTO 8 OHMS (Min. RMS power per channel, 20Hz-20kHz, both channels driven, with no more than the rated distortion)		100 W (20 dBW)
Rated distortion (THD, 20Hz-20kHz)		0.03%
Clipping power (maximum continuous power per channel)		130 W
IHF Dynamic Headroom at 8 ohms		+5.7 dB
IHF Dynamic Power (maximum short-term power per channel)	8 ohms 4 ohms 2 ohms	370 W (25.7 dBW) 400 W (26 dBW) 440 W (26.4 dBW)
Slew Factor		>50
Slew Rate		>30 V/μsec
Damping Factor (ref. 8 ohms, 50 Hz)		>100
Input Impedance		R = 20kΩ C = 600pF
Input Sensitivity	for 1W out for rated power	100mV 1.0V
Voltage Gain		28 × (29 dB)
Frequency Response, LAB Input		3 Hz to 100 kHz +0, -3 dB
Infrasonic Filter, NORMAL Input		-3 dB at 10Hz, 12 dB/octave
Ultrasonic Filter, NORMAL Input		-3 dB at 80 kHz, 12 dB/octave
Signal/Noise Ratio, A-weighted		98 dB ref. 1W 118 dB ref. rated power
THD (Total Harmonic Distortion, 20Hz-20kHz, from 250mW to rated output)		<0.03%
SMPTE I.M. (Intermodulation Distortion, 60Hz + 7kHz, 4:1, from 250mW to rated output)		<0.03%
IHF I.M. (CCIF IM Distortion, 19 + 20 kHz at rated output)		<0.03%

BRIDGED (MONOPHONIC) MODE

CONTINUOUS AVERAGE POWER OUTPUT INTO 8 OHMS

300 W (24.7 dBW)*

(Min. RMS power, 20Hz-20kHz, with no more than the rated distortion)

IHF Dynamic Headroom at 8 ohms

+4.3 dB

IHF Dynamic Power (maximum short-term power)

8 ohms	800 W (29 dBW)
4 ohms	880 W (29.4 dBW)

* In some countries local regulations require that bridged 8 ohm power be measured with the speaker impedance switch in the 4 ohm position resulting in a bridged RMS output of 200W(23dBW).

PHYSICAL SPECIFICATIONS

Width × Height × Depth

43.5 × 12.06 × 38.1 cm.
(17.1 × 4.75 × 15 in.)

Net Weight

10 kg. (22 lb)

Shipping Weight

12.02 kg (26.5 lb)

Power Consumption

50/60 Hz at 110,
120,220, or 240 V.
390 VA

Specifications are those in effect at the time of printing. NAD reserves the right to change specifications or designs at any time without notice.

MAIN AMPLIFIER ALIGNMENT

IMPORTANT NOTES

1. Before adjusting, remove input signal and load, and set speaker impedance switch to 8Ω (HIGH); reset to 4Ω (NORMAL) when finished.
2. These adjustments are always necessary after repair to main amplifier.
3. After repair, it is recommended to use current limiter (200-250W lightbulb) in mains line, for initial turn-on.

A. CENTER VOLTAGE CHECK

1. Connect DVM from Ground to R436, L chan (R486, R chan).
2. Turn power on, and check for reading of 0V ± 100mVDC.

B. IDLE CURRENT ADJUSTMENT

1. Connect DVM from TP401 to TP402, L chan (TP451, TP452 R chan).
2. Adjust R418, L chan (R468, R chan) for reading of 14mV ± 1mVDC.

C. FINAL ADJUSTMENT

1. Leave power on minimum 5 minutes.
2. Repeat center voltage check and idle current adjustment.

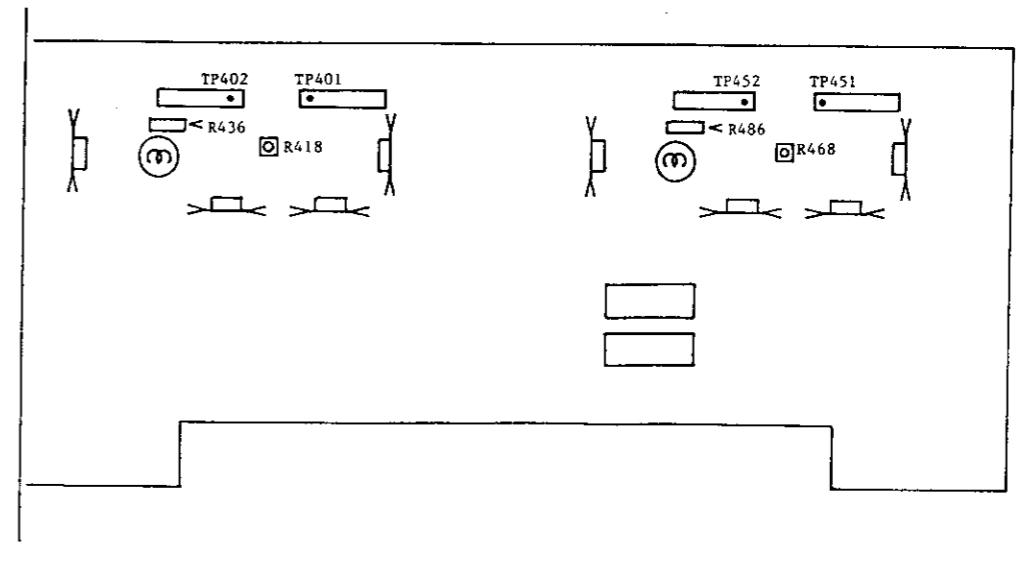

SCHEMATIC, AMPLIFIER

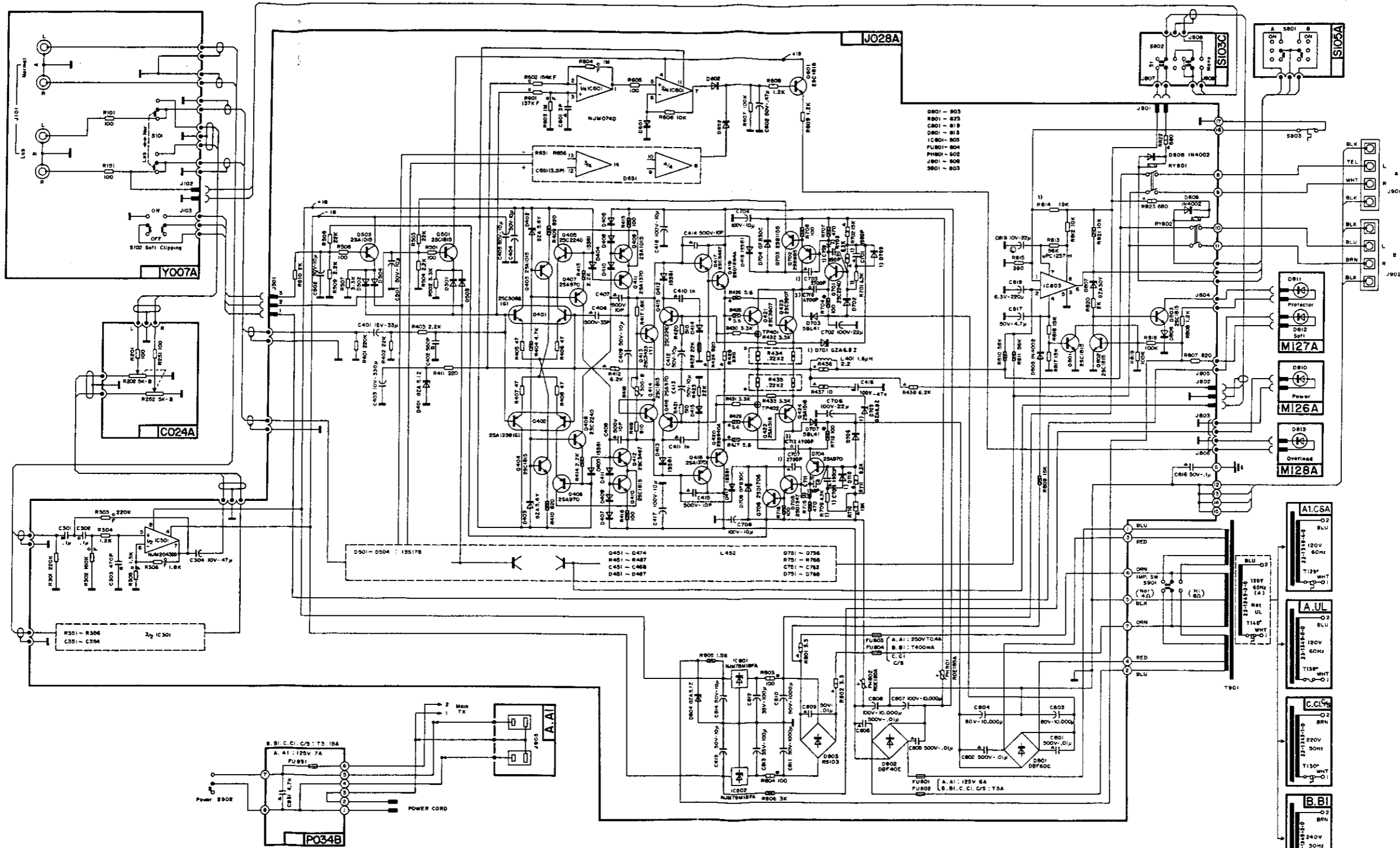

- MARK OF RESISTORS
- $\frac{1}{2}$ 1/2
 - $\frac{1}{4}$ 1/4
 - Number : W
 - O Metal Film
 - F Film
 - W Carbon
 - A Metal Oxide Film
 - NO MARK Diode : 1SS178
 - F 1%
- MARK OF CAPACITORS
- ELECT LOW LEAK
 - CERAMIC
 - FILM
- 1) SER. NO. 52000 - 52150
 R814 : 3.9K
 D709, 710, 759, 760 : 1SS178 Not used.
 C708, 711, 752, 751 : 150PF Not used.
 D701, 705, 751, 755 : 52AS.1Z
 R701, 705, 751, 755 : 15K
 C701, 705, 751, 755 : 120PF
 C703, 751, 752, 751 : 470PF
 2) SER. NO. 52000 - 52150
 3) MARK. R706, 714, 754, 754 : 1K
 3) SER. NO. 52000 - 52150

NAD Main AMPLIFIER
2400 (249)

P.C.B. LAYOUT

**INPUT P.C.B. ASS'Y
(Y007A)**

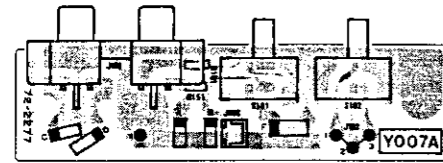

**MAINS INPUT P.C.B. ASS'Y
(P034B)**

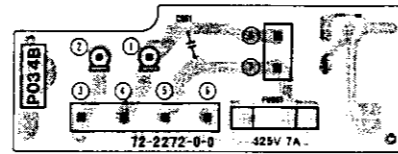

**POWER INDICATOR ASS'Y
(M126A)**



**SOFT CLIPPING/PROTECTION
INDICATOR ASS'Y
(M127A)**

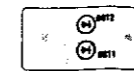

**OVERLOAD INDICATOR
ASS'Y
(M128A)**



MAIN/SUPPLY P.C.B. ASS'Y (J028A)

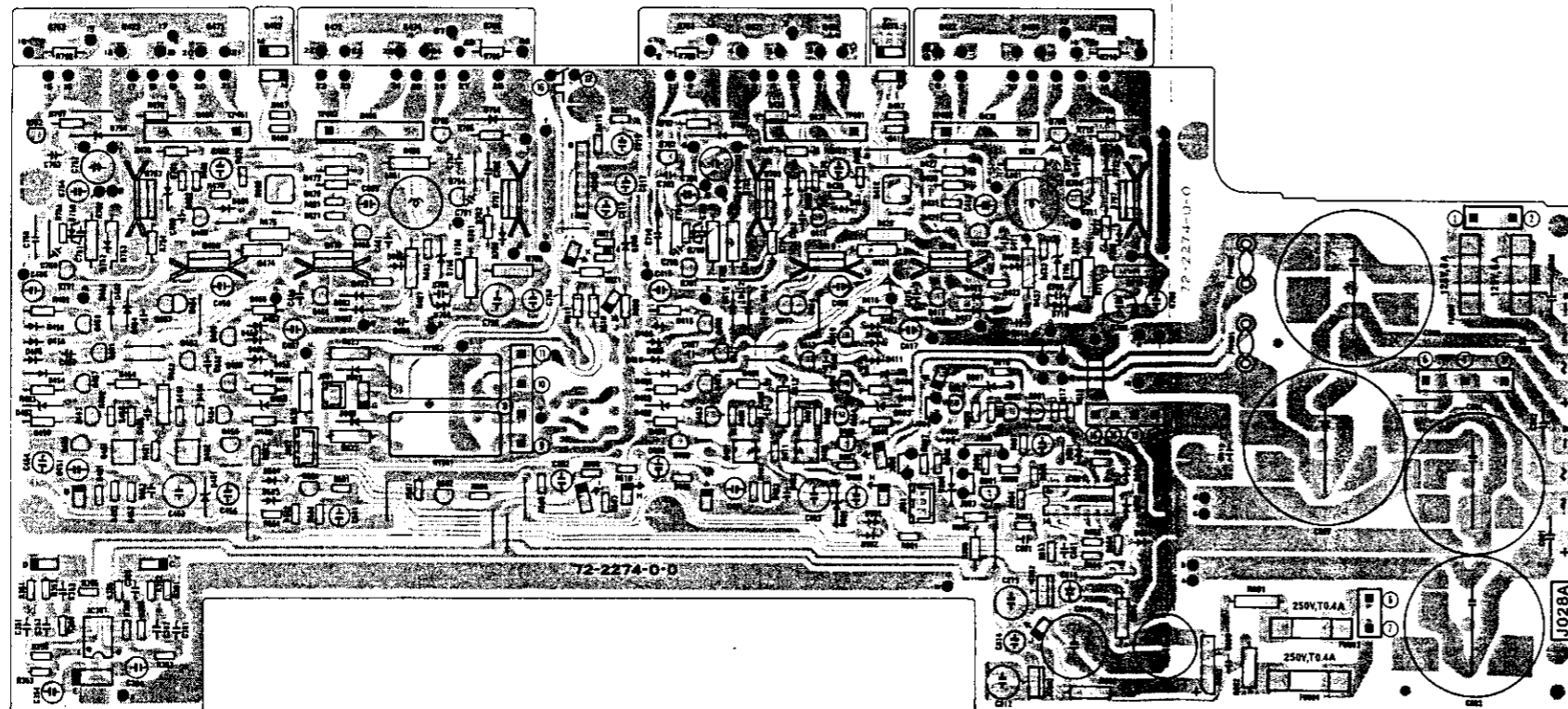

**BRIDGE SWITCH ASS'Y
(S103C)**



**SPEAKER SWITCH ASS'Y
(S105A)**

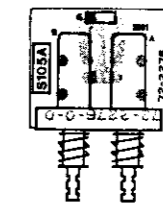

**VOLUME CONTROL ASS'Y
(0024A)**

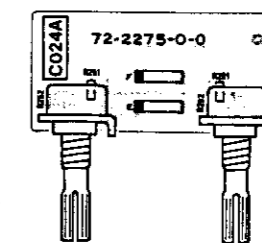

WIRING DIAGRAM

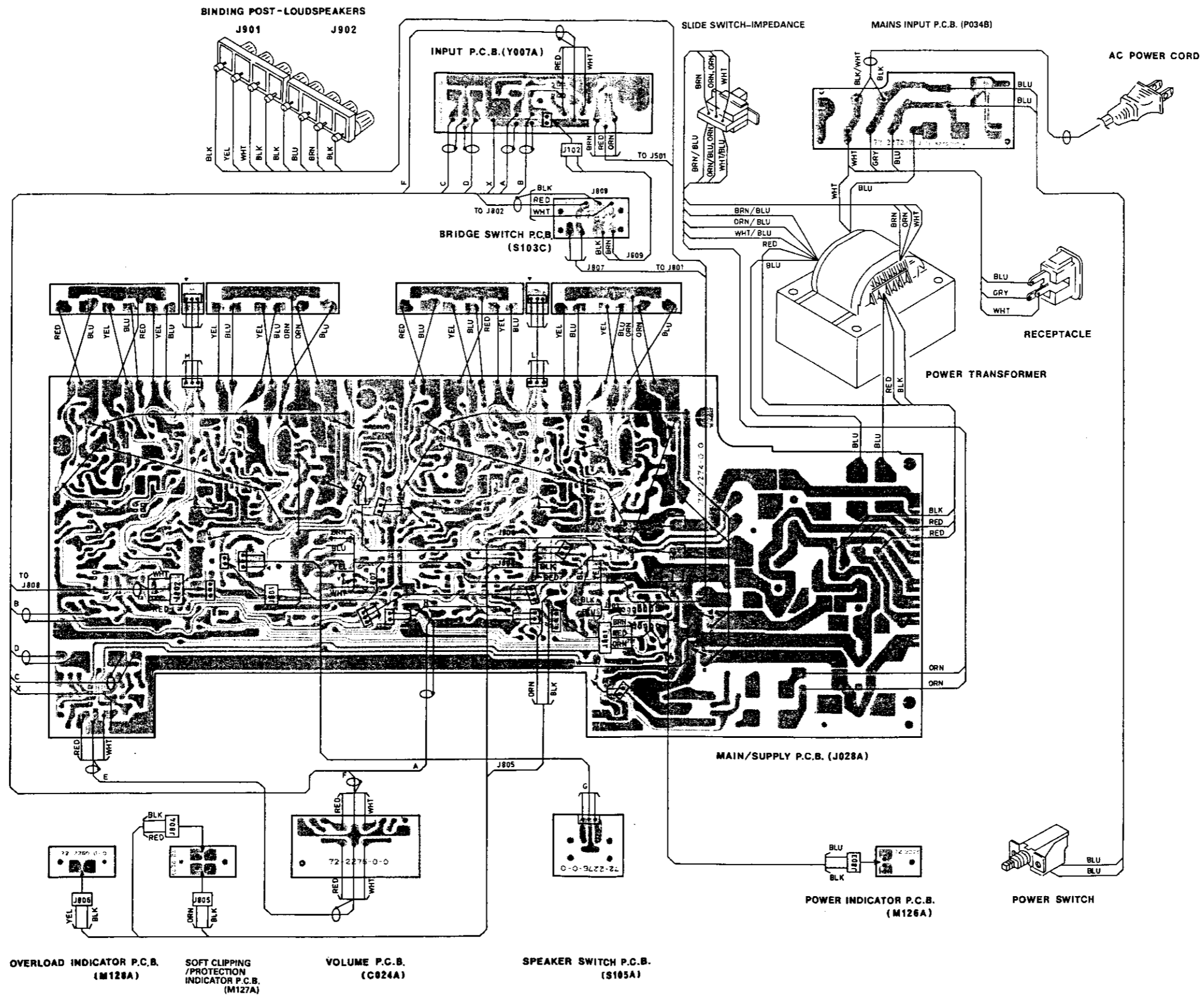

EXPLODED VIEW

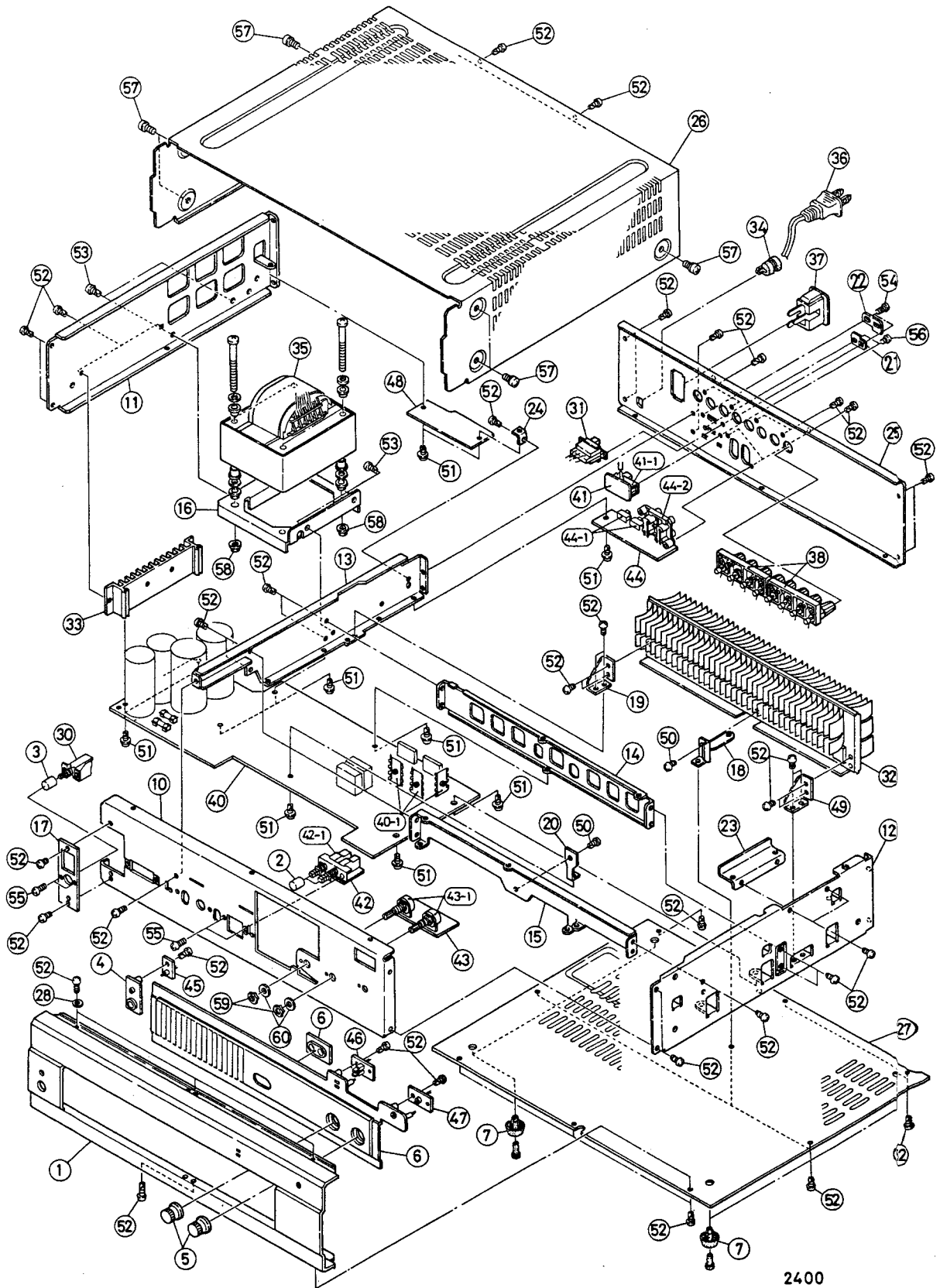

2400

EXPLODED VIEW PARTS LIST

Index No.	Parts No.	Description
1	63-6301-0-0	Front Panel
2	62-1111-0-0	Push Button(Black)-Selectors
3	62-1111-1-0	Push Button(Green)-On/Off
4	62-3480-0-0	Push Button Frame
5	62-2331-0-0	Rotary Knob-Volume
6	62- 410-0-0	Sub Panel
7	92-2116-0-0	Foot
10	71-2691-0-0	Front Chassis
11	71-2682-0-0	Side Chassis (L)
12	71-2683-0-0	Side Chassis (R)
13	71-2686-0-0	Sub Chassis-Front to Rear Support
14	71-2647-1-1	Sub Chassis-Left to Right Support
15	71-2689-0-0	Sub Chassis-Left to Right Support
16	71-1966-0-0	Trans. Chassis
17	71-1969-0-0	Switch Stand
18	71-1972-0-0	Bracket-PCB Support
19	71-1973-0-0	Bracket-Heatsink
20	71-1970-0-0	L Bracket-PCB Support
21	92-1262-0-0	Lock Plate-Bridge Switch
22	92-1263-0-0	Lock Plate-Impedance Switch
23	71-1935-0-0	Wire Holder
24	71-1967-0-0	L Bracket-PCB Support
25	71-2688-0-0	Rear Panel (A, A1)
	71-2694-0-0	Rear Panel (B, B1, C, C1, C/S)
26	71-3136-0-0	Top Cover
27	71-3135-0-0	Bottom Cover
28		Washer (Plain 3.5-8-0.5)
30	81-2343-0-0	Power Switch
31	81- 452-0-0	Slide Switch-Impedance
32	74-3124-0-0	Heatsink, Main
33	74-3125-0-0	Heatsink, Rectifier
34	62-3332-0-0	Bushing-AC Power Cord
35	23-1349-0-0	Power Transformer (UL)
	23-1349-1-0	Power Transformer (C, C1, C/S)
	23-1349-2-0	Power Transformer (B, B1)
	23-1349-3-0	Power Transformer (A)
	23-1349-4-0	Power Transformer (A1)
36	85- 267-0-0	AC Power Cord (A, A1)
	85- 240-0-0	AC Power Cord (B)
	85- 259-0-0	AC Power Cord (B1)
36	85- 235-0-0	AC Power Cord (C, C1, C/S)
37	82-2207-0-0	Receptacle (A, A1)
	82-2127-0-1	Receptacle (B, C, C1, C/S)
38	86- 216-0-0	Speaker Terminal (A, A1, B, B1, C, C1)
	86- 217-0-0	Speaker Terminal (C/S)
40	J028A	Main/Supply Pcb Assembly
40-1	74-3118-0-0	Heatsink, Driver
41	S103C	Bridge Switch Assembly
41-1	81- 493-0-0	Slide Switch-Bridge Mono/Stereo
42	S105A	Speaker Switch Assembly
42-1	81-2365-0-0	Push Switch-Speaker A/B

Index No.	Parts No.	Description
43	C024A	Volume Control Assembly
43-1	41- 140-0-1	Rotary Potentiometer-Volume
44	Y007A	Input Pcb Assembly
44-1	81- 447-0-0	Slide Switch-Infrasonic ON/OFF
		Slide Switch-Soft Clipping ON/OFF
44-2	82-2157-0-0	RCA Connector (Double)
45	M126A	Power Indicator Assembly
46	M127A	Soft Clipping/Protection Indicator Assembly
47	M128A	Overload Indicator Assembly
48	P034B	Mains Input Assembly
49	71-1973-0-0	Bracket-Heatsink
50		Tapping Screw (Philips Head 3 × 6 Cr)
51		Tapping Screw (Washer Head 3 × 6 Cr)
52		Tapping Screw (Philips Head 3 × 8 Blk)
53		Tapping Screw (Philips Head 4 × 6 Cr)
54		Machine Screw (Philips Head 2.6 × 4 Blk)
55		Machine Screw (Pan 3 × 6 Cr)
56		Machine Screw (Philips Head 3 × 8 Blk)
57		Cabinet Screw with Washer (4 × 6 Blk)
58		Hexagon Flange Nut (M4 Cr)
59		Volume Control Nut (Hexagon 7-11-2)
60		Washer (Plain 7-12-0.5)

ELECTRICAL PARTS LIST

NOTE: This is not a complete electrical parts list.

1) MAIN/SUPPLY PCB ASSEMBLY: J028A (EXPLODED VIEW INDEX No.40)

PARTS NO.	SYMBOL NO.	DESCRIPTION
NJM2043DD	IC301	IC, DUAL AMP
NJM074D	IC601	IC, DUAL AMP
NJM78M18FA	IC801	IC, REG 18V 0.5A
NJM79M18FA	IC802	IC, REG -18V 0.5A
μPC1237H or HA	IC803	IC, PROTECT
2SC3066	Q401, 451.	TRANSISTOR
2SA1239	Q402, 452.	TRANSISTOR
2SA1015	Q403, 409, 453, 459, 502.	TRANSISTOR
2SC1815	Q404, 410, 414, 454, 460, 464, 501, 601, 801-803.	TRANSISTOR
2SC2240	Q405, 408, 415, 455, 458, 701, 751, 765.	TRANSISTOR
2SA970	Q406, 407, 416, 456, 457, 466, 704, 754.	TRANSISTOR
2SA1370	Q411, 418, 461, 468.	TRANSISTOR
2SC3467	Q412, 417, 462, 467.	TRANSISTOR
2SD1264	Q419, 469.	TRANSISTOR
2SB940A	Q420, 470.	TRANSISTOR
2SB985	Q702, 752.	TRANSISTOR
2SD1347	Q705, 755.	TRANSISTOR
GZA5.1Z	D401, 451, 804.	ZENER DIODE
GZA5.6Y	D402, 403, 452, 453.	ZENER DIODE
1SS81	D404, 405, 412, 413, 416, 417, 454, 455, 462, 463, 466, 467.	DIODE
GZA6.8Z	D701, 705, 751, 755.	ZENER DIODE
5BL41	D703, 707, 753, 757.	DIODE
GFB30C	D704, 708, 754, 758.	DIODE
RS103	D803	DIODE
1N4002	D805, 808, 809.	DIODE
GZA30Y	D807	ZENER DIODE
1SS178	OTHERS	DIODE
15-147	L401, 451.	CHOKE COIL (1.6μH)
80V, 10000μF	C803, 804.	ELECT. CAPACITOR, LGS-4
100V, 10000μF	C807, 808.	ELECT. CAPACITOR, LGS-4
10V, 22μF	C819	ELECT. CAPACITOR, LOW LEAKAGE
41-7116	R418, 468.	VARIABLE RESISTOR (EVN-D4A)
160KΩ, 1/6W	R302, 352.	METAL FILM RESISTOR (RNK1/6)
220KΩ, 1/6W	R303, 353.	METAL FILM RESISTOR (RNK1/6)
1.5KΩ, 1/6W	R305, 355.	METAL FILM RESISTOR (RNK1/6)
1.8KΩ, 1/6W	R306, 356.	METAL FILM RESISTOR (RNK1/6)
6.2KΩ, 1W	R412, 438, 462.	OXIDE METAL RESISTOR (RS1FSM)
820Ω, 1W	R424, 474.	OXIDE METAL RESISTOR (EVN-D4A)
330Ω, 1W	R425, 475.	OXIDE METAL RESISTOR (EVN-D4A)

PARTS NO.	SYMBOL NO.	DESCRIPTION
5.6Ω, 1/4W	R426-429, 476-479.	FUSIBLE RESISTOR (ERD2FC)
100Ω, 1W	R803, 804.	FUSIBLE RESISTOR (ERQ1A101PS)
100Ω, 1/4W	R704, 712, 754, 762.	FUSIBLE RESISTOR (ERD2FCG)
0.22 + 0.22Ω	R434, 435, 484, 485.	CEMENTED RESISTOR (MPC725)
2.2Ω, 2W	R436, 486.	OXIDE METAL RESISTOR (RS2FSM)
10Ω, 2W	R437, 487.	OXIDE METAL RESISTOR (RS2FSM)
137KΩ, 1/6W	R601, 651.	METAL FILM RESISTOR (RNK1/6)
154KΩ, 1/6W	R602, 652.	METAL FILM RESISTOR (RNK1/6)
1MΩ, 1/6W	R603, 604, 653, 654.	METAL FILM RESISTOR (RNK1/6)
15KΩ, 2W	R702, 710, 752, 760.	OXIDE METAL RESISTOR (RNK1/6)
8.2KΩ, 2W	R703, 711, 753, 761.	OXIDE METAL RESISTOR (RNK1/6)
3.3KΩ, 1W	R801, 802.	OXIDE METAL RESISTOR (RNK1/6)
680Ω, 1W	R822, 823.	OXIDE METAL RESISTOR (RS1FSM)
△ 81-622-1-0	RY801, 802.	RELAY, MR72, SPEAKER
△ RDE185A	PH801, 802.	P.T.C. (POLYSWITCH)
△ 81-7011	S803(16-17)	THERMOSTAT (90°C)
△ 5MF6	FU801, 802. (A, A1)	FUSE (125V, 6A)
EAK5A	" , " (B, B1, C, C1, C/S)	FUSE (250V, T5A)
△ 5TT400	FU803, 804. (A, A1)	FUSE (250V, 400mA)
EAWK400mA	" , " (B, B1, C, C1, C/S)	FUSE (250V, T400mA)

2) MAINS INPUT PCB ASSEMBLY; P034B (EXPLODED VIEW INDEX No.48)

PARTS NO.	SYMBOL NO.	DESCRIPTION
△ ECK-DNS472ZV(4700p)	C951 (A, A1)	CERAMIC CAPACITOR
ECK-DNS472MEX(4700p)	" (B, B1, C, C1, C/S)	CERAMIC CAPACITOR
△ 5MF7	FU951 (A, A1)	FUSE (125V, 7A)
EAK3.15A	" (B, B1, C, C1, C/S)	FUSE (250V, T3.15A)

3) POWER, SOFT/PROTECT, OVERLOAD IND. ASSEMBLIES; M126-128A (EXPLODED VIEW INDEX Nos.45~47)

PARTS NO.	SYMBOL NO.	DESCRIPTION
SLP246B	D810	LED (GREEN)
TLR208	D811	LED (RED)
TLO208	D812	LED (YELLOW)
SLP146B	D813	LED (RED)

4) CHASSIS-MOUNTED COMPONENTS: 24921

PARTS NO.	SYMBOL NO.	DESCRIPTION
△ 2SC3423	Q413, 463.	TRANSISTOR
△ 2SC3907	Q421, 423, 471, 473.	TRANSISTOR
△ 2SA1516	Q422, 424, 472, 474.	TRANSISTOR
△ 2SB1155	Q703, 753.	TRANSISTOR
△ 2SD1706	Q706, 756.	TRANSISTOR
△ DBF60C	D801	DIODE
△ DBF40E	D802	DIODE