

NAD **SERVICE**
MANUAL

902

**MULTI CHANNEL
AMPLIFIER**

CONTENTS

DESCRIPTION	PAGE
FRONT / REAR PANEL VIEW	3
SPECIFICATIONS	4
WIRING DIAGRAM	5-6
SCHEMATIC DIAGRAM	7-8
PCB LAYOUT (PARTS SIDE)	9-10
AMPLIFIER ADJUSTMENT	11
EXPLODED VIEW	12
EXPLODED PARTS LIST	13
PARTS LIST	14-15
PACKING DIAGRAM	16
SERVICE CONTACT INFORMATION	17

FRONT/REAR PANEL VIEW

FRONT PANEL

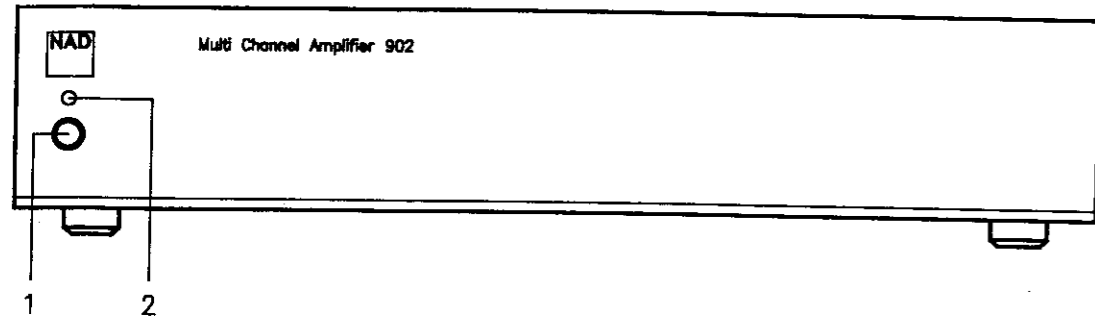

1. Power Button
2. Power LED

REAR PANEL CONNECTIONS

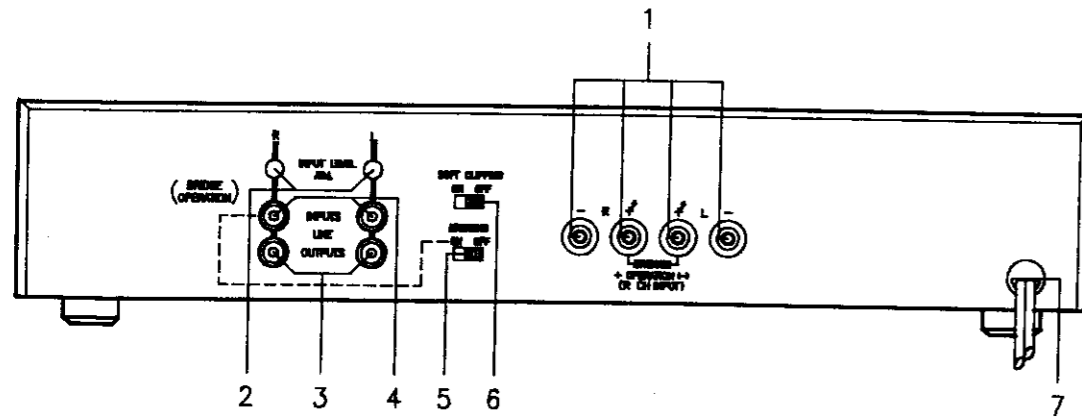

1. Speaker Terminals (CH 1, CH 2)
2. Input Level Adj. (CH 1, CH 2)
3. Line Output (CH 1, CH 2)
4. Input (CH 1, CH 2)
5. Bridging On/Off (CH 1, CH 2)
6. Soft Clipping On/Off (CH 1, CH 2)
7. AC Line Cord

SPECIFICATION

Measured in accordance with EIA Standard RS-490 (IHF A -202)
NAD-902 Multi-Channel Amplifier

Continues RMS. power output into 8/4 ohms load, Both channels driven	> 30/35 W
Continues RMS. power output into 8 ohms load, (BRIDGED mode)	> 90 W
Rated distortion (THD. 20Hz. - 20kHz.)	< 0.04%
Slew factor	> 50
Slew rate	35V / uSEC.
Damping factor (ref. 8 ohm, 1kHz)	> 100
Input impedance	10k ohm // 220 pf
Input sensitivity (for 1W output)	185 mV
(for rated power)	1000mV
Voltage gain	24.5 dB
Frequency response (-3 dB)	< 10 Hz / 100kHz
(20 Hz - 20k Hz).....	< -0.2 dB
S/N Ratio (A-weighted)	> 100 dB
(un-weighted)	> 90 dB
THD. (ref. 250mW output)	< 0.04%
SMPTE IMP. (ref. 250mW output)	< 0.04%
PHYSICAL SPECIFICATIONS	
Width * Height * Depth	420 * 80 * 250 mm
Net Weight	4.7 kg
Shipping Weight	5.7 kg

Specifications are those in effect at the time of printing. NAD reserves the right to change specifications

PCB LAYOUT (PARTS SIDE)

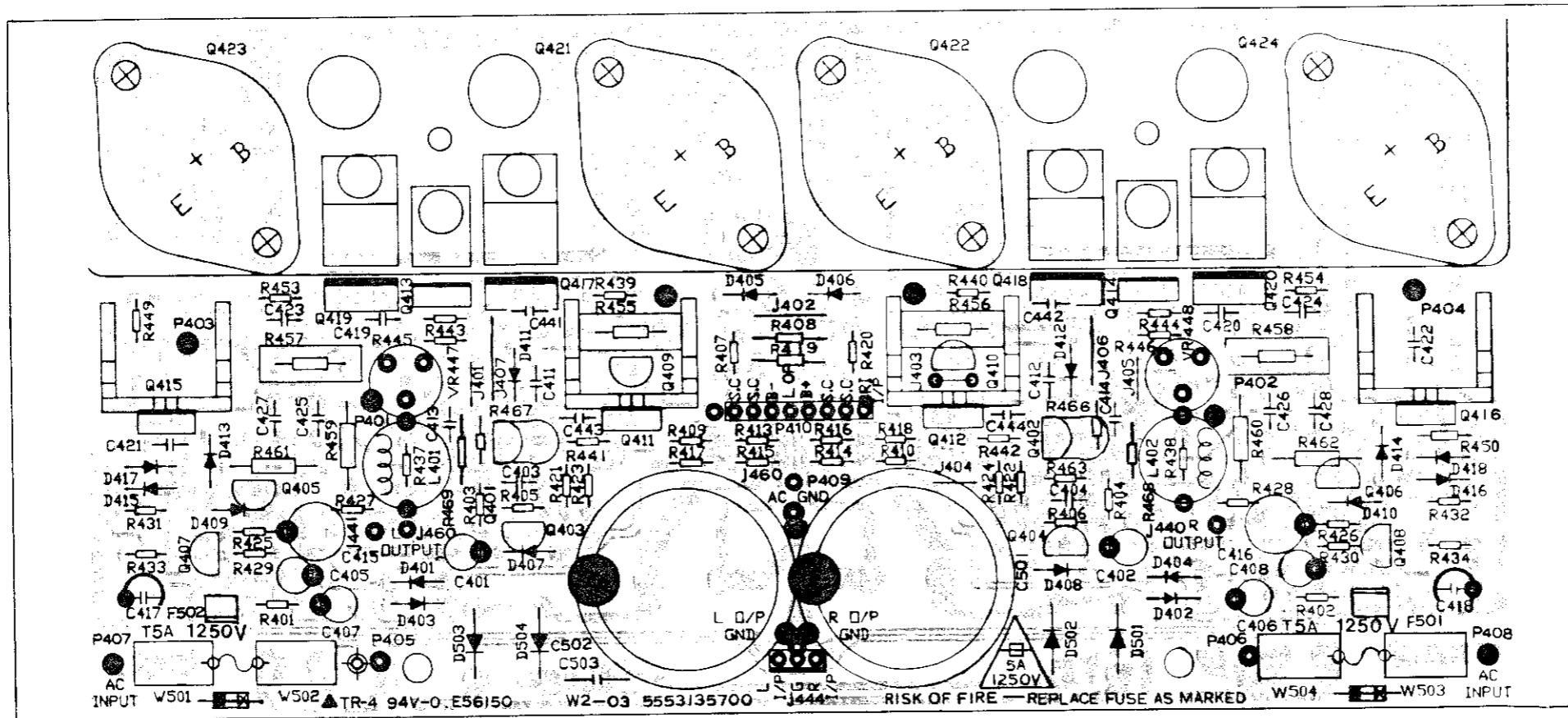
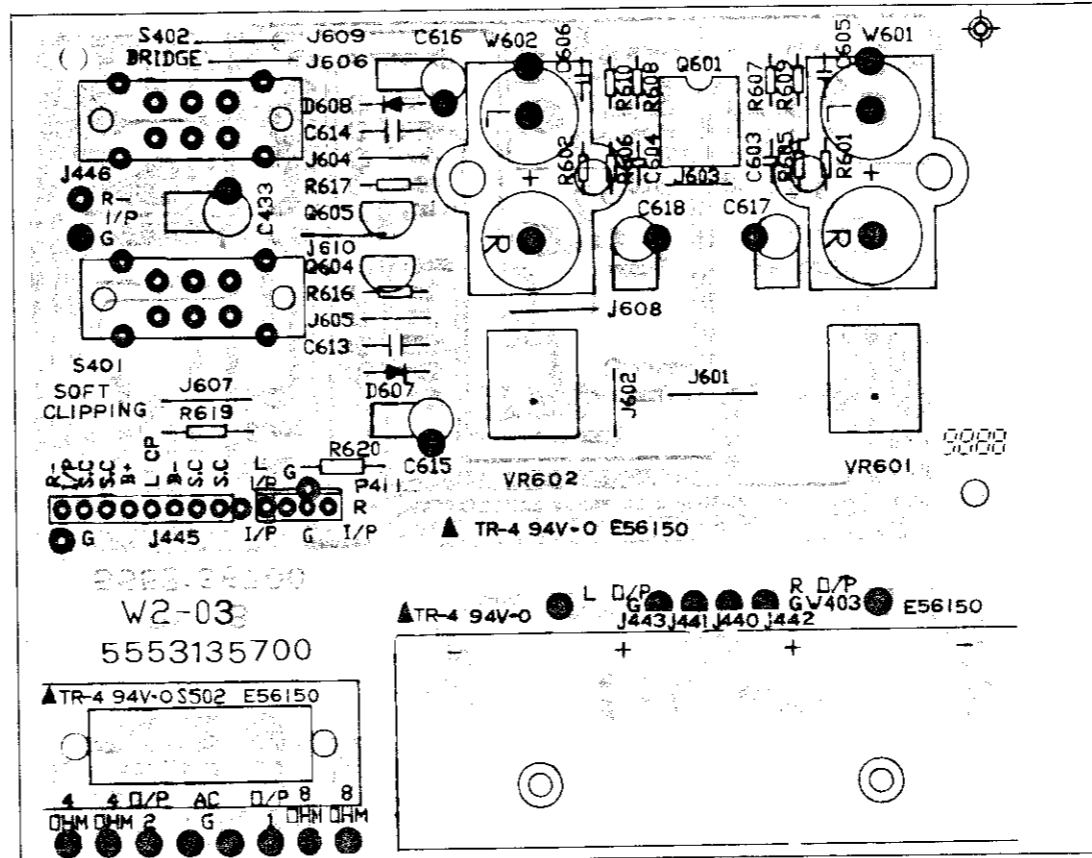
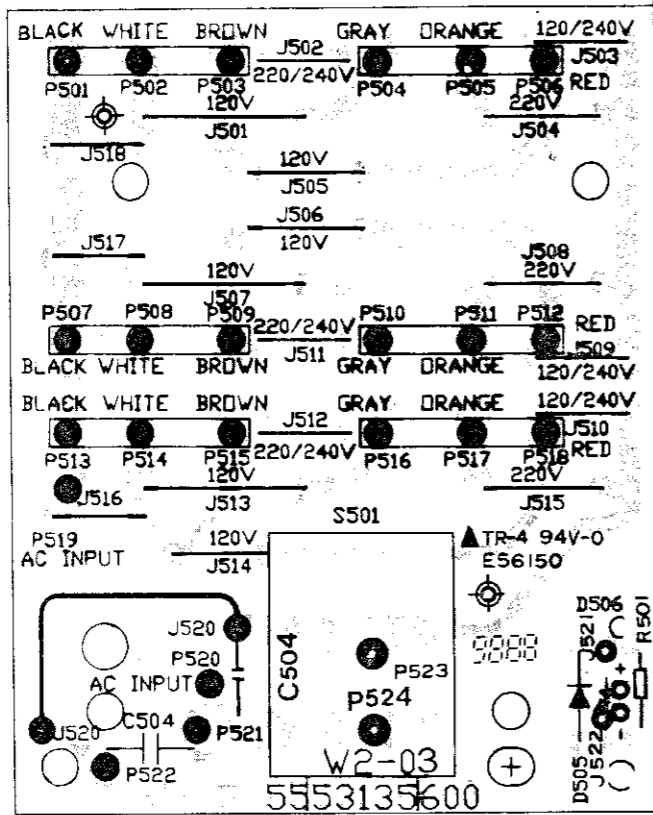

AMPLIFIER ADJUSTMENT

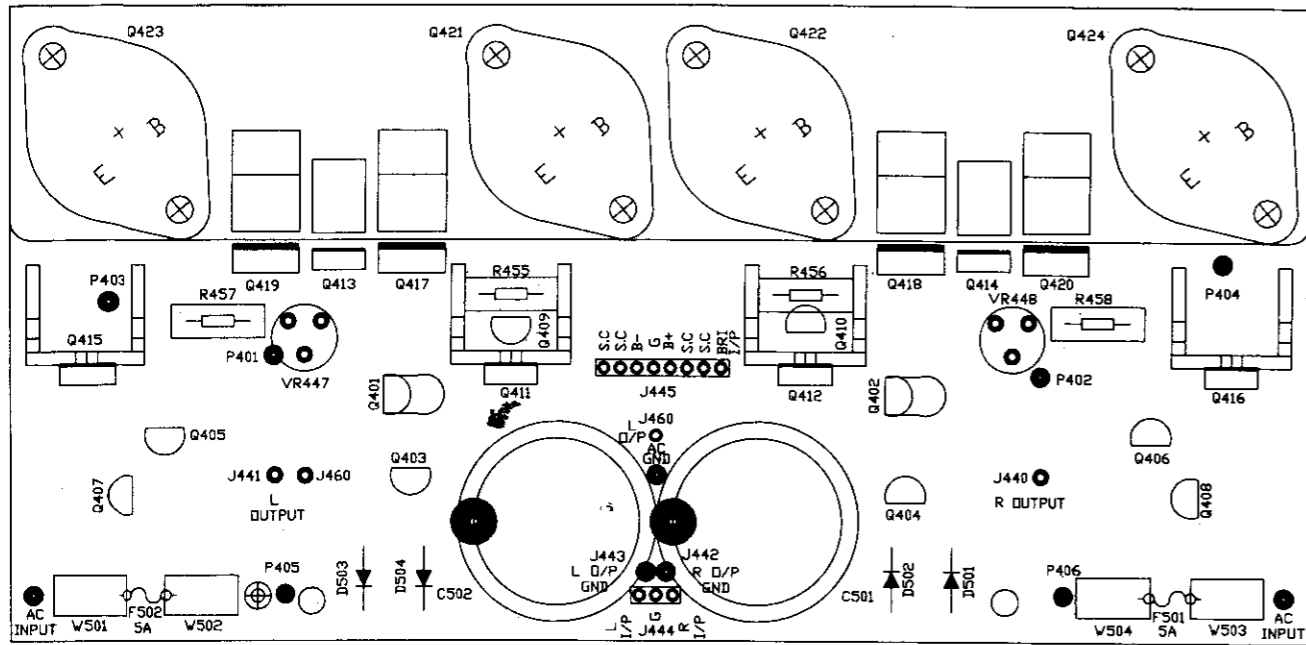

A. IDLE CURRENT ADJUSTMENT

1. Connect DMM across P-401 (+) and P-403 (-), adjust VR-447 for reading of 5mV +/- 0.5mV DC.(without a load across the output terminals.)
- 2 Repeat, using P-402 (+) and P-404 (-), adjust VR-448.
3. Repeat above procedures for each amplifier module.

B. FINAL ADJUSTMENT

1. Leave power on minimum 5 minutes.
- 2 Repeat idle current adjustments.

EXPLODED VIEW

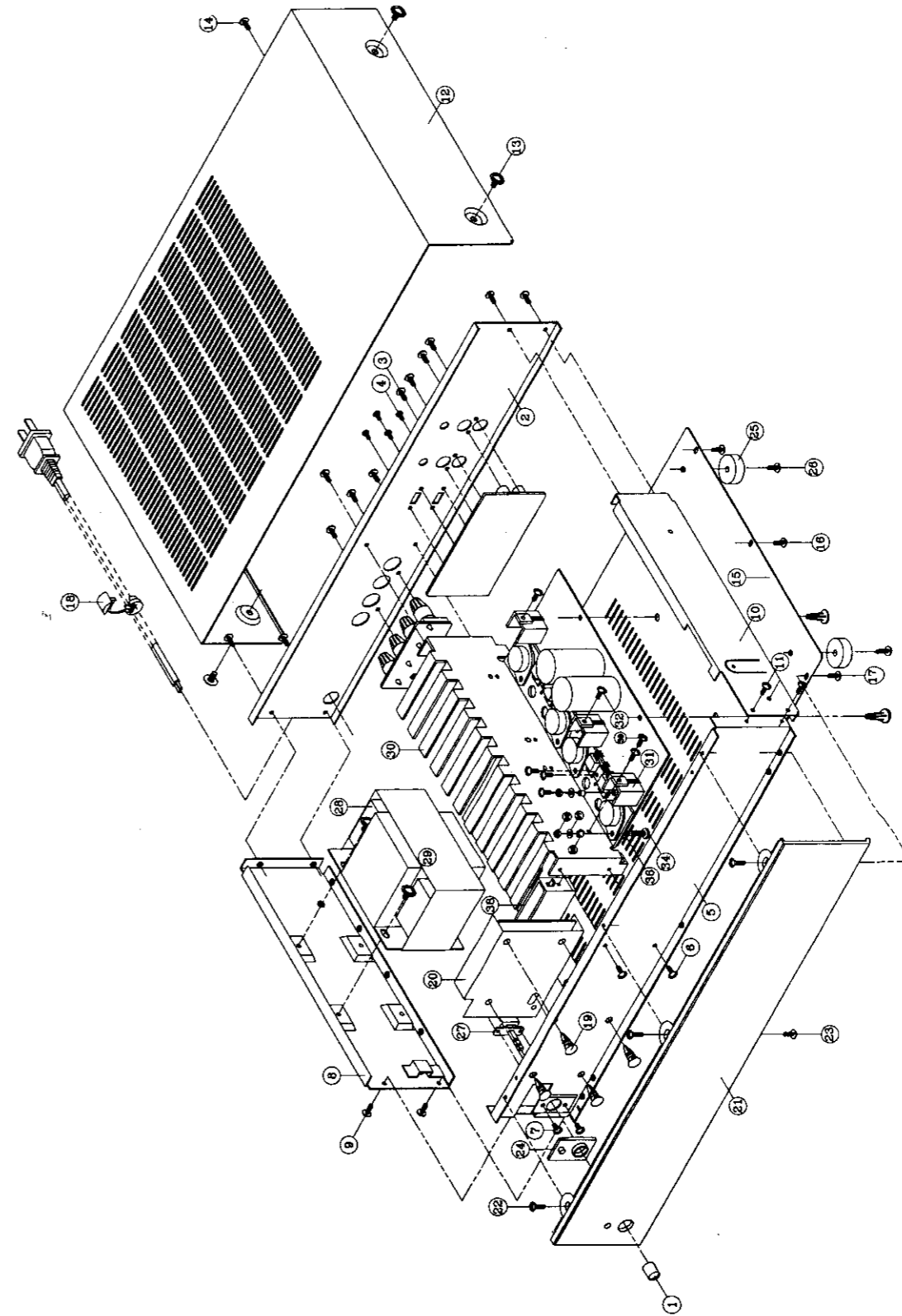

EXPLODED PARTS LIST

NO.	PART NO.	DESCRIPTION	Q'TY
1	5541539000	PUSH KNOB	1
2	5547138200	BACK PLATE	1
3	7033161156	SCREW BRB M3x8 S-PC	12
4	7001120216	SCREW PAN M2.5x4	4
5	5547138100	FRONT PLATE	1
6	7033160652	SCREW BRB M3x6 ZN-CC	2
7	7001170612	SCREW BRB M3x8 S-PC	2
8	5547128700	PLATE LEFT	1
9	7033160652	SCREW BRB M3x6 ZN-CC	2
10	5547128810	PLATE RIGHT	1
11	7033160652	SCREW BRB M3x6 ZN-CC	2
12	5541002100	TOP COVER	1
13	7190550003	SCREW ISO PPW M4x6 S-PC	4
14	7033161156	SCREW BRB M3x8 S-PC	1
15	5547138300	CHASSIS	1
16	7033160652	SCREW BRB M3x6 ZN-CC	7
17	7033161156	SCREW BRB M3x8 S-PC	2
18	5547501200	BUSHING POWER CORD	1
19	5547530460	PCB SUPPORT	6
20	5547533100	POWER SW. SHIELDER	1
21	5541215100	FRONT PANEL	1
22	7034161152	SCREW BFB M3x8 ZN-CC	3
23	7033161156	SCREW BRB M3x8 S-PC	1
24	5542226100	POWER BEZEL	1
25	5547802120	FOOT	4
26	7000305022	SCREW BTBW M3x10 ZN-CC	4
27	5554436100	POWER SWITCH	1
28	5561320900	POWER TRANSFORMER	1
29	7134250652	SCREW PZS M4x6	4
30	5545309800	HEAT SINK	1
31	5545306910	HEAK SINK	4
32	7033161152	SCREW BRB M3x8 ZN-CC	4
33	7076170012	NUT ISO N3 ZN-CC	8
34	7001171412	SCREW ISO PP M3x10 ZN-CC	8
35	5547528700	TRANSISTOR WASHER	8
36	7101200302	WASHER TOOTH LOOK EXT M3	8
37	7098160002	SPRING WASHER SW3 ZN-CC	8
38	5545308200	HEAT SINK	4
39	7033161152	SCREW BRB M3x8 ZN-CC	4

SYMBOL NO.	Q'TY	PARTS NO.	DESCRIPTION	SPECIFICATION
	1	5090306052	CHASSIS ASS'Y	NAD-902
3F01	1	5541539000	PUSH KNOB	NAD-2100
5B01	1	5547138200	BACK PLATE	NAD-902 110V
5B01M	12	7033161156	SCREW BRB M3.0x08 S-PC	C PAN MS PC
5B01N	4	7001120216	SCREW	C PAN M2.5x4 MS PC
5C01	1	5547138100	FRONT PLATE	NAD-902
5C01M	2	7033160652	SCREW BRB M3.0x06 S-ZN-CC	C RUD 3006 TS ZN-CC
5C01N	2	7001170612	SCREW ISO PP M3.0x06 S-ZN-CC	C PAN
5C02	1	5547128710	PLATE LEFT	NAD-3225/7225
5C02M	2	7033160652	SCREW BRB M3.0x06 S-ZN-CC	C RUD 3006 TS ZN-CC
5C03	1	5547128810	PLATE RIGHT	NAD-310
5C03M	2	7033160652	SCREW BRB M3.0x06 S-ZN-CC	C RUD 3006 TS ZN-CC
5F01	1	5541002100	TOP COVER	NAD-310
5F01M	4	7190550003	SCREW ISO PPW ZN-PC (BLK)	M4.0x06 (10x3.6x1.0T)
5F01N	1	7033161156	SCREW BRB M3.0x08 S-PC	C PAN MS PC
5F01P	1	5535448400	LIGHTNING LABEL	UL
5S01	1	5547138300	CHASSIS	NAD-902
5S01M	7	7033160652	SCREW BRB M3.0x06 S-ZN-CC	C RUD 3006 TS ZN-CC
5S01N	2	7033161156	SCREW BRB M3.0x08 S-PC	C PAN MS PC
5S01P	1	5535448400	LIGHTNING LABEL	UL
6B01	1	5547501200	BUSHING POWER CORD	SR-4N-4 & B-7
6C01	4	5547530460	PCB SUPPORT	SCB-6
6C02	1	5547533100	POWER SW. SHIELDER	NAD-906
6F01	1	5541215100	FRONT PANEL	NAD-902
6F01M	3	7034161152	SCREW BPB M3.0x08 S-ZN-CC	C FLT
6F01N	1	7033161156	SCREW BRB M3.0x08 S-PC	C RUD
6F010	1	7033160652	SCREW BRB M3.0x06 S-ZN-CC	C RUD 3006 TS ZN-CC
6F02	1	5542226100	POWER BEZEL	NAD-2100
6S01	2	5547530460	PCB SUPPORT	SCB-6
6S02	4	5547802120	FOOT	NAD-7100
6S02M	4	7000305022	SCREW BTBW M3x10 S-ZN-CC	
D506	1	6118017300	DIODE LED	EL103GD 2MM GREEN
S501	1	5554436100	POWER SWITCH (UL/CSA)	SDDL81007U-TT
T501	1	5561320900	POWER TRANSFORMER	TAM-PT-1210 (NAD-906)
T501M	4	7134250652	SCREW PZS M4.0x06	PZS M4.0x06
U501	1	5556702121	POWER CORD W/PLUG BLK SP-12	UL/CSA SPT-2 41/0.16x2Cx2.1M
	1	5090506008	PCB BLOCK	NAD-902
	1	5090406069	MAIN PCB ASS'Y	NAD-902
	1	5090906164	MAIN AMP. PCB BLOCK	NAD-902
7401	1	5545309800	HEAT SINK	NAD-902
7401M	2	7033161152	SCREW BRB M3.0x08 S-ZN-CC	C RUD 3008 TS ZN-CC
7401N	4	7033161152	SCREW BRB M3.0x08 S-ZN-CC	C RUD 3008 TS ZN-CC
74010	4	5545308200	HEAT SINK	NAD-3225/7225
B401	1	5553135700	MAIN AMP. PCB (305x95)	NAD-906
C401, C402	2	5213222091	CAP. EL.	22UFM +/-20% 10V
C403, C404	2	5247122191	CAP. EL.	220PFK +/-10% 50V
C405-C408	4	5213222091	CAP. EL.	22UFM +/-20% 10V
C411, C412	2	5247033091	CAP. CERAMIC CC45	33PFJ +/-5% 50V
C413, C414	2	5247106091	CAP. CERAMIC CC45	6PFD 50V
C415, C416	2	5213322191	CAP. EL.	220UFM +/-20% 16V
C417, C418	2	5213601091	CAP. EL.	1UFM +/-20% 50V
C419, C420	2	5222110491	CAP. POLYESTER	0.10MFJ +/-5% 50V
C423-C428	6	5222110491	CAP. POLYESTER	0.10MFJ +/-5% 50V
C443, C444	2	5222110491	CAP. POLYESTER	0.10MFJ +/-5% 50V
C445, C446	2	5232000100	CAP. CERAMIC CK45	0.01uFM +/-20% 500V
C445J, C446J	2	6707020140	INSULATION TUBING PVC UL CSA	T=105 AWG15 600V BLK 1.4mm
C501, C502	2	5210308100	CAP. EL. 25x50	6800UFM +/-20% 50V
D401-D404	4	6613003030	DIODE SWITCHING ITT	1N4148
D405, D406	2	6615006242	DIODE SWITCHING HIT	HZ15-2-TA
D407, D408	2	6613003030	DIODE SWITCHING ITT	1N4148
D409, D410	2	6615019740	DIODE ZENER HIT	HZ2C2-TA
D411-D414	4	6613007141	DIODE SWITCHING HIT	1SS81 200V 1A T=52mm .1
D415-D418	4	6613003030	DIODE SWITCHING ITT	1N4148
D501-D504	4	6611000800	DIODE RECTIFIER GIT	1N5401 100V 3.0A G
F501, F502	2	5554307501	FUSE UL/CSA 5.2 x 20 5MT5	125V 5A MEDIUM BLOW
L401, L402	2	5562000800	COIL SPRING	10#Px1.0#P23ZIT(2.2UH!S10"*)
P401-P409	9	5556201900	SQUARE PIN	1.1x1.1x16
P410	1	5556103308	CONNECTOR	52011-0810
Q401, Q402	2	6621034501	TR NPN HF	2SC3067G VCEO=120V IC=50mA
Q403, Q404	2	6623002050	TR PNP HF	2SA1015-Y TPE2 TAPING
Q405, Q406	2	6621016701	TR NPN HF	2SC2240-GR LOW NOISE
Q407, Q408	2	6621015332	TR NPN HF	2SA1815-Y TPE2
Q409, Q410	2	6623005000	TR PNP HF	2SA970-GR
Q411	1	6623003200	TR PNP HF	2SA1380D/E
Q411M	1	5547024210	HEAT SINK	NAD-7220/3220
Q411N	1	7033161152	SCREW BRB M3.0x08 S-ZN-CC	C RUD 3008 TS ZN-CC
Q412	1	6623003200	TR PNP HF	2SA1380D/E
Q412M	1	5547024210	HEAT SINK	NAD-7220/3220
Q412N	1	7033161152	SCREW BRB M3.0x08 S-ZN-CC	C RUD 3008 TS ZN-CC
Q413	1	6621034600	TR NPN HF	2SC3423-Y PC=1.2W HFE=120-240
Q413M	1	7134161452	SCREW, TS BRAZIER HEAD S-TITE	M3.0X10 S-ZN-CC
Q414	1	6621034600	TR NPN HF	2SC3423-Y PC=1.2W HFE=120-240
Q414M	1	7134161452	SCREW, TS BRAZIER HEAD S-TITE	M3.0X10 S-ZN-CC
Q415	1	6621016900	TR NPN HF	2SC3502D/E W/IS-126
Q415M	1	5547024210	HEAT SINK	NAD-7220/3220
Q415N	1	7033161152	SCREW BRB M3.0x08 S-ZN-CC	C RUD 3008 TS ZN-CC
Q416	1	6621016900	TR NPN HF	2SC3502D/E W/IS-126
Q416M	1	5547024210	HEAT SINK	NAD-7220/3220
Q416N	1	7033161152	SCREW BRB M3.0x08 S-ZN-CC	C RUD 3008 TS ZN-CC
Q417	1	6621035000	TR NPN HF	2SC2344-E M:IS-313A B:M
Q417M	1	7134161452	SCREW, TS BRAZIER HEAD S-TITE	M3.0X10 S-ZN-CC
Q418	1	6621035000	TR NPN HF	2SC2344-E M:IS-313A B:M

SYMBOL NO.	Q'TY	PARTS NO.	DESCRIPTION	SPECIFICATION
Q418M	1	7134161452	SCREW, TS BRAZIER HEAD S-TITE	M3.0X10 S-ZN-CC
Q419	1	6623011600	TR PNP HF	2SA1011-E M:IS-313A B:M
Q419M	1	7134161452	SCREW, TS BRAZIER HEAD S-TITE	M3.0X10 S-ZN-CC
Q420	1	6623011600	TR PNP HF	2SA1011-E M:IS-313A B:M
Q420M	1	7134161452	SCREW, TS BRAZIER HEAD S-TITE	M3.0X10 S-ZN-CC
Q421	1	6622003100	TR PNP LF	MJ15022
Q421M	2	7101200302	WASHER TOOTH LOCK-EXT M3.0	M3.0 S-ZN-CC
Q421N	2	7098160002	SPRING WASHER SW3 S-ZN-CC	D3.1xD5.9x0.7T
Q421O	2	7076170012	SCREW ISO M3.0(2.4H) S-ZN-CC	
Q421P	2	7001171412	SCREW ISO PP S-ZN-CC	C PAN M3.0x10
Q421Q	2	5547528700	TRANSISTOR WASHER	NAD-7220/3220
Q422	1	6622003100	TR PNP LF	MJ15022
Q422M	2	7101200302	WASHER TOOTH LOCK-EXT M3.0	M3.0 S-ZN-CC
Q422N	2	7098160002	SPRING WASHER SW3 S-ZN-CC	D3.1xD5.9x0.7T
Q422O	2	7076170012	NUT ISO M3.0(2.4H) S-ZN-CC	M3.0x12+SW S-ZN-CC
Q422P	2	7001171412	SCREW ISO PP S-ZN-CC	C PAN M3.0x10
Q422Q	2	5547528700	TRANSISTOR WASHER	NAD-7220/3220
Q423	1	6624002000	TR PNP LF	MJ15023
Q423M	2	7101200302	WASHER TOOTH LOCK-EXT M3.0	M3.0 S-ZN-CC
Q423N	2	7098160002	SPRING WASHER SW3 S-ZN-CC	D3.1xD5.9x0.7T
Q423O	2	7076170012	NUT ISO M3.0(2.4H) S-ZN-CC	M3.0x12+SW S-ZN-CC
Q423P	2	7001171412	SCREW ISO PP S-ZN-CC	C PAN M3.0x10
Q423Q	2	5547528700	TRANSISTOR WASHER	NAD-7220/3220
Q424	1	6624002000	TR PNP LF	MJ15023
Q424M	2	7101200302	WASHER TOOTH LOCK-EXT M3.0	M3.0 S-ZN-CC
Q424N	2	7098160002	SPRING WASHER SW3 S-ZN-CC	D3.1xD5.9x0.7T
Q424O	2	7076170012	NUT ISO M3.0(2.4H) S-ZN-CC	M3.0x12+SW S-ZN-CC
Q424P	2	7001171412	SCREW ISO PP S-ZN-CC	C PAN M3.0x10
Q424Q	2	5547528700	TRANSISTOR WASHER	NAD-7220/3220
R401, R402	2	5142122290	RES. CARBON FILM	2K2 1/6W
R403, R404	2	5142122390	RES. CARBON FILM	22K +/-5% 1/6W
R405, R406	2	5142147190	RES. CARBON FILM	470 +/-5% 1/6W
R407, R408	2	5142115390	RES. CARBON FILM	15K +/-5% 1/6W
R409, R410	2	5142191190	RES. CARBON FILM	910 +/-5% 1/6W
R413, R416	4	5142118290	RES. CARBON FILM	1K8 +/-5% 1/6W
R417, R418	2	5142191190	RES. CARBON FILM	910 +/-5% 1/6W
R419, R420	2	5142115390	RES. CARBON FILM	15K +/-5% 1/6W
R421, R424	4	5142110190	RES. CARBON FILM	100 +/-5% 1/6W
R425, R426	2	5142112290	RES. CARBON FILM	1K2 +/-5% 1/6W
R427, R428	2	5142143190	RES. CARBON FILM	430 +/-5% 1/6W
R429, R430	2	5142110390	RES. CARBON FILM	10K +/-5% 1/6W
R431, R432	2	5142147190	RES. CARBON FILM	470 +/-5% 1/6W
R433, R434	2	5142122290	RES. CARBON FILM	2K2 1/6W
R437, R438	2	5142168290	RES. CARBON FILM	6K8 +/-5% 1/6W
R439, R440	2	5142147290	RES. CARBON FILM	4K7 +/-5% 1/6W
R441, R442	2	5142139090	RES. CARBON FILM	39 +/-5% 1/6W
R443, R444	2	5142118290	RES. CARBON FILM	1K8 +/-5% 1/6W
R445, R446	2	5142182190	RES. CARBON FILM	820 +/-5% 1/6W
R449, R450	2	5142133090	RES. CARBON FILM	33 +/-5% 1/6W
R453, R454	2	5142133190	RES. CARBON FILM	330 +/-5% 1/6W
R455, R458	4	5136003200	RES. METAL PLATE CEMENT	0.22 +/-10% 5W
R459, R460	2	5130339903	RES. METAL OXIDE FILM MINI	3.9 +/-5% 1W
R461, R462	2	5130310003	RES. METAL OXIDE FILM MINI	10 +/-5% 1W
R463	1	5142168290	RES. CARBON FILM	6K8 +/-5% 1/6W
R466, R467	2	5142122290	RES. CARBON FILM	2K2 1/6W
R468, R469	2	5142110390	RES. CARBON FILM	10K +/-5% 1/6W
VR447, VR448	2	5162160420	RES. VR PNO6FB221AR	220 OHM +/-20% F5x5
W501, W504	4	5547032210	FUSE CLIP (5.2)	CG-203S
	1	5090906165	SPEAKER TERMINAL PCB BLOCK	NAD-906
W403	1	5556205420	SPEAKER TERMINAL	SO-6249
	1	5090906166	IN/OUT JACK PCB BLOCK	NAD-906
C433	1	5213322091	CAP. EL.	22UFM +/-20% 16V
C603-C606	4	5247068091	CAP. CERAMIC CC45	68PFJ +/-5% 50V
C613, C614	2	5236110491	CAP. SEMI.	0.1UFK +/-10% 25V
C615, C616	2	5213447091	CAP. EL.	47UFM +/-20% 25V
C617, C618	2	5213222091	CAP. EL.	22UFM +/-20% 10V
D607, D608	2	6615019043	DIODE ZENER	HZ18-2-TA
P411	1	5556101904	MALE WAFER 4P	1L-G-4P-S3L2-E
Q601	1	6644066700	IC LINEAR	NJM2068DLN DIP8
Q604	1	6621015332	TR. NPN HF	2SC1815-Y TPE2
Q605	1	6623002050	TR. PNP HF	2SA1015-Y TPE2 TAPING
R601, R602	2	5142110290	RES. CARBON FILM	1K +/-5% 1/6W
R605, R608	4	5142110490	RES. CARBON FILM	100K +/-5% 1/6W
R609, R610	2	5142110290	RES. CARBON FILM	1K +/-5% 1/6W
R616, R617	2	5142110390	RES. CARBON FILM	10K +/-5% 1/6W
R619, R620	2	5133810103	RES. FUSIBLE	100 +/-5% 1/4W 14A
S401	1	5554439900	SLIDE SWITCH	SLWK22-09
S401	1	5554431610	SLIDE SWITCH	SSSE022NB1-NB1-TT
S402	1	5554439900	SLIDE SWITCH	SLWK22-09
S402	1	5554431610	SLIDE SWITCH	SSSE022NB1-NB1-TT
VR601, VR602	2	5169010532	VR.	20KB TT RK09K1130008
W601, W602	2	5556207600	2P JACK-RCA	12-2238
	1	5090406070	POWER TERMINAL PCB ASS'Y	NAD-902
D505	1	5090906167	POWER LED PCB BLOCK	NAD-902
R501	1	6611007230	DIODE RECTIFIER	1N4002 100V 1A T=26MM
	1	5142147290	RES. CARBON FILM	4K7 +/-5% 1/6W
	1	5090906168	POWER TERMINAL PCB BLOCK	NAD-902
B501	1	5553135600	POWER SWITCH PCB (69x95)	NAD-906
C504	1	5230102701	CAP. CERAMIC CK45 (KC)	4700PFM* +/-20% 400V
S401, S402	2	5554439900	SLIDE SWITCH	SLWK22-09

PACKING DIAGRAM

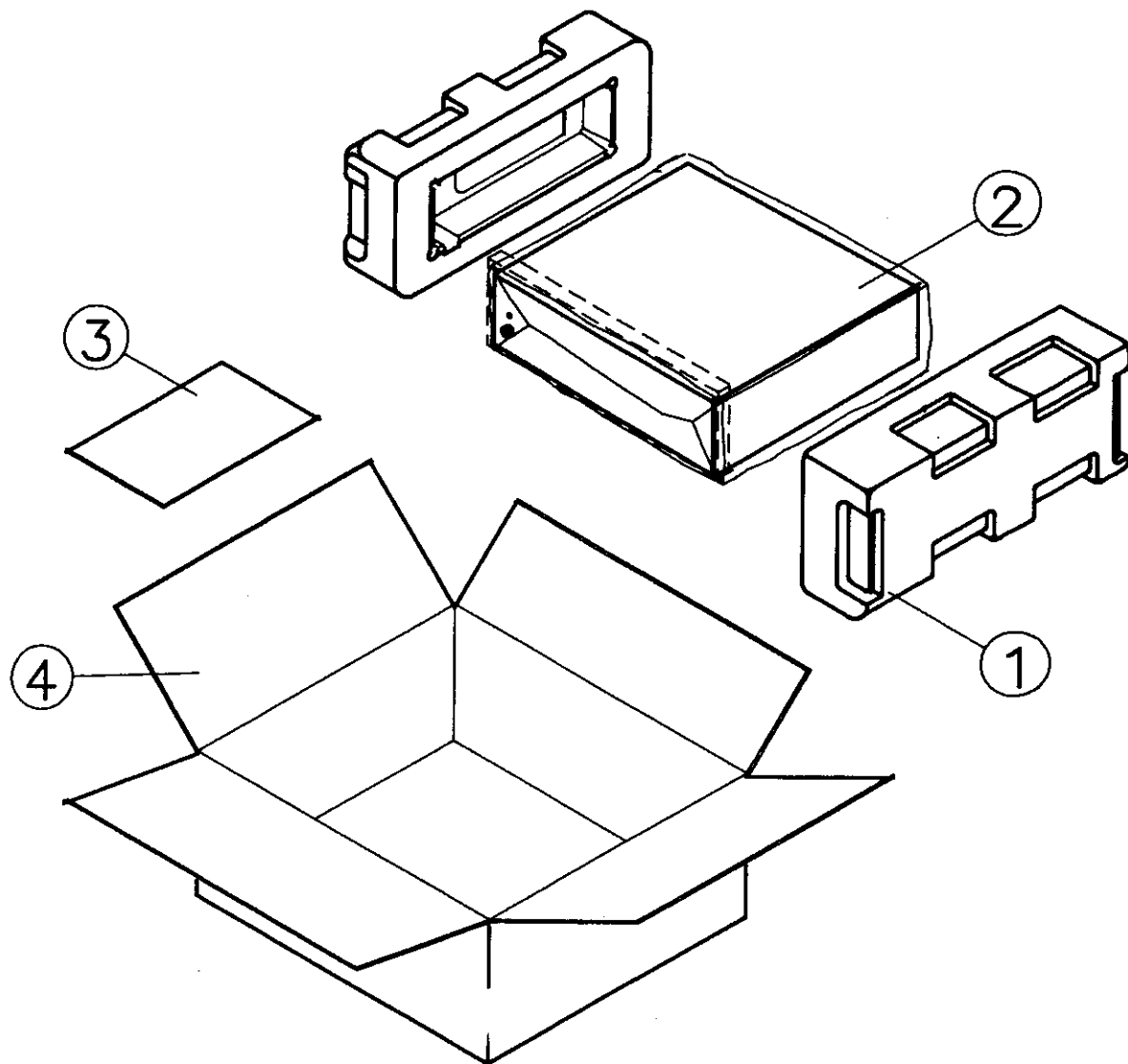

ITEM	PARTS NO.	PARTS NAME	Q'TY
1	9520520155	EPS PAD	1
2	9530520155	EPE BAG	1
3	5535122554	OWNER'S MANUAL	1
4	9510523355	INNER CARTON	1

NOTES:

Proprietary information for servicing purposes only. The information given herein may not be used commercially without the prior written agreement of NAD Electronics LTD, London, England.