

SERVICE MANUAL

NAD

SERVICE SAFETY PRECAUTIONS (UL)

1. Use exact replacement parts for critical locations marked "⚠"
2. Return lead dress to original position and re-install protective covers.
3. Before returning to customer, test for shock hazard; use either method A or B:

A. Leakage test "cold":

1. Unplug the AC cord; turn power switch ON.
2. Connect one lead of High Voltage Insulation Tester to both prongs of the AC plug.
3. Touch other lead to all exposed metal parts.
4. Impedance measurement must be 0.3-5.0 Megohms.

B. Leakage test, "live" :

1. Plug unit directly into the AC outlet: do not use isolation transformer.
2. Connect one lead of the Leakage Current Tester to earth ground.
3. Touch other lead to all exposed metal parts.
4. Leakage measurement must be less than 0.5 milliamps.

712

TUNER AMPLIFIER

712

TUNER AMPLIFIER

SERVICE SAFETY PRECAUTIONS

1. Replacing the fuses



This symbol located near the fuse indicates that the fuse used is fast operating type. For continued protection against fire hazard, replace with same type fuse. For fuse rating refer to the marking adjacent to the symbol.

<u>Reference No</u>	<u>Part Number</u>	<u>Description</u>
F503-F504*AH	5120-0019-0	Fuse 4A 125V Time Lag LBC (UL/CSA)
F503-F504*B,B1,C	5120-0017-0	Fuse 4A 250V Time Lag HBC (SEMKO/VDE)
F505-F507*AH	5120-0026-0	Fuse 315mA 250V Time Lag LBC (UL/CSA)
F505-F507*B,B1,C	5120-0027-0	Fuse 315mA 250V Time Lag LBC (SEMKO/VDE)

NOTE :

- <*AH > : USA, CANADIAN MODEL ONLY.
- <*B > : UK MODEL ONLY.
- <*B1 > : AUSTRALIAN MODEL ONLY.
- <*C > : EUROPEAN MODEL ONLY.

2. Safety-check out

(Only U.S.A. model)

After correcting the original service problem perform the following safety check before releasing the set to the customer.

Connect the insulating-resistance tester between the plug of power supply cord and the screw on the back panel.

Specifications : 3.3 Mohm \pm 10% at 500V.

CONTENTS

DESCRIPTION	PAGE
SPECIFICATIONS	4-5
REAR PANEL / FRONT PANEL VIEW.....	6
BLOCK DIAGRAM	7
WIRING DIAGRAM	8
DISASSEMBLY INSTRUCTIONS	9
ADJUSTMENT POINTS DIAGRAM	10
ALIGNMENT PROCEDURE	11-12
PCB LAYOUT	13-16
SCHEMATIC DIAGRAM	17-26
IC BLOCK DIAGRAM	27-30
EXPLODED VIEW	31
EXPLODED VIEW PARTS LIST	32-33
ELECTRICAL PARTS LIST	34-39
PACKING DIAGRAM / PACKING LIST.....	40

SPECIFICATIONS

POWER AMPLIFIER SECTION

THD (0.25W-30W, 20 Hz-20 kHz)		≤ 0.03%
Continuous Power Output	8-ohm	≥ 30W
(0.03% THD)	4-ohm	≥ 30W
Clipping Power Output		
(1kHz, 0.1% THD)	8-ohm	≥ 33W
Signal / Noise Ratio		
(A-wtd, ref. 1W, 220-ohm source)	8-ohm	≥ 99 dB
Frequency Response (20 Hz-20 kHz)		0 ± 0.6 dB
Dynamic Power (1 kHz)	8-ohm	≥ 50W
Damping Factor at 50 Hz	8-ohm	≥ 50
Input Sensitivity (30W)	8-ohm	1.07 ± 0.05 V
Channel Separation	1 kHz	≥ 70 dB
(15W)	10 kHz	≥ 60 dB
Soft Clipping (0.1% THD, 8-ohm)		
THD (SC ON)		≤ 10%
Output Reduction(SC ON)		≤ 1.5 dB

PREAMPLIFIER SECTION

Input Sensitivity (1V out, pre-out)		165 ± 20 mV
Frequency Response		
(20 Hz-20 kHz, 500 mV in/out, pre-out)		0 ± 0.6 dB
THD (20Hz-20KHz, 2V in/out, pre-out)		≤ 0.02%
Signal / Noise Ratio	8-ohm	≥ 85 dB
(A-wtd, 1W SPK out, 1K-ohm source, 500 mV in)		
Tone Control Responses		
Bass (50 Hz)		± 10 ± 1.5 dB
Treble (10 kHz)		± 7 ± 1.5 dB
Channel Balance L & R		
Maximum Volume (15W)		± 0.5 dB
-1 dB to -20 dB		± 1.5 dB
-21 dB to -60 dB		± 3 dB
-61 dB to -70 dB		± 5 dB
Channel Separation	1 kHz	≥ 65 dB
(2V in/out, pre-out)	10 kHz	≥ 55 dB
Crosstalk		
Source-to-Source	1 kHz	≥ 83 dB
(2V in/out, pre-out)	10 kHz	≥ 68 dB
Tape replay-to-tape record	1 kHz	≥ 75 dB
(2V in/out, tape out)	10 kHz	≥ 60 dB
Maximum Output Level (0.1%THD, 500 mV)		
Pre-out	1 kHz	≥ 6 V
Headphone (600-ohm load)	1 kHz	≥ 10 V
Maximum Input Signal		
(0.1%THD, pre-out)	1 kHz	≥ 6 V

FM TUNER SECTION

Input level is expressed as the reading in open-circuit of 75-ohm source impedance signal generator

Usable Sensitivity (98 MHz)

50 dB Quieting

Mono

Stereo

60 dB Quieting

Mono

Stereo

Signal / Noise Ratio

Mono

(60 dBμ, IHF wtd)

Stereo

Frequency Response (30 Hz - 15 kHz, 60 dBμ)

Channel Separation (60 dBμ)

30 Hz

1 kHz

10 kHz

Alternate Channel Selectivity

(40 dBμ, ± 400 kHz)

Capture Ratio (40 dBμ)

AM Suppression

(60 dBμ, 100% Mod.FM, 30% Mod AM)

Image Rejection (119.4 MHz)

I.F. Rejection (10.7 MHz)

Pilot Suppression (60 dBμ)

THD (60 dBμ, 100%Mod. for AH, 40% Mod. for C, 1 kHz)

Mono

L - R

L + R

Auto-Search Sensitivity

Center Tune Sensitivity

Stereo Indicator Sensitivity

On

Off

AM TUNER SECTION

Usable Sensitivity (1000 kHz or 999 kHz)

Signal / Noise Ratio

(66 dBμ, 30% Mod, 1000 kHz or 999 kHz)

THD (66 dBμ, 1000 kHz or 999 kHz)

Adjacent Channel Selectivity

(± 10 kHz or ± 9 kHz)

Image Rejection (1900 kHz or 1899 kHz)

I.F. Rejection (450 kHz)

Auto-Search sensitivity

DIMENSIONS AND WEIGHTS

Net Weight : 6.9 kg, 15.2 lb

Shipping Weight : 8 kg, 17.6 lb

Dimensions (WxHxD) : 435 x 110 x 310 mm

***B,*B1,*C**

≤ 23 dBμ

≤ 21 dBμ

≤ 40 dBμ

≤ 31 dBμ

≤ 50 dBμ

≥ 73 dB

≥ 65 dB

0 ± 0.7 dB

≥ 30 dB

≥ 32 dB

≥ 27 dB

≥ 65 dB

≤ 7 dB

≥ 54 dB

≥ 74 dB

≥ 75 dB

≥ 60 dB

≤ 0.2%

≤ 0.3%

≤ 0.2%

27 ± 5 dBμ

20 ± 3 dBμ

23 ± 4 dBμ

21 ± 4 dBμ

***AH**

≤ 9.5 dBμ

≤ 14 dBμ

≤ 36 dBμ

≤ 23 dBμ

≤ 46 dBμ

≥ 73 dB

≥ 70 dB

0 ± 0.7 dB

≥ 35 dB

≥ 41 dB

≥ 32 dB

≥ 60 dB

≤ 2 dB

≥ 54 dB

≥ 74 dB

≥ 75 dB

≥ 60 dB

≤ 0.2%

≤ 0.12%

≤ 0.2%

27 ± 5 dBμ

20 ± 3 dBμ

23 ± 4 dBμ

21 ± 4 dBμ

REAR PANEL / FRONT PANEL VIEW

FRONT PANEL

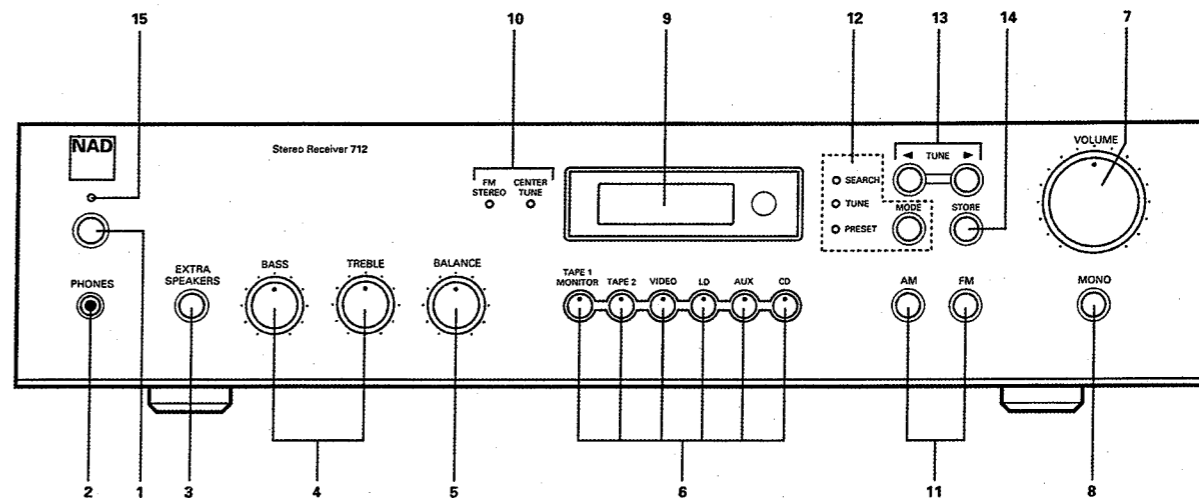

1. POWER SWITCH
2. PHONES SOCKET
3. EXTRA SPEAKERS
4. BASS & TREBLE CONTROL
5. BALANCE CONTROL
6. TAPE 1 MONITOR, TAPE 2, VIDEO, LD, AUX, CD
7. VOLUME CONTROL
8. MONO
9. DISPLAY PANEL
10. FM STEREO AND CENTER TUNE INDICATORS
11. AM AND FM SELECTOR
12. MODE SWITCH AND INDICATORS
13. TUNE UP/DOWN
14. STORE
15. STAND BY INDICATOR

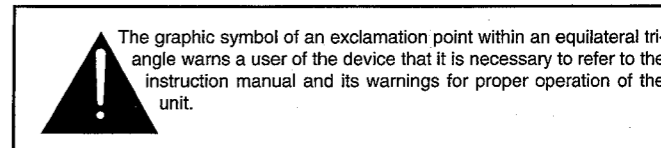
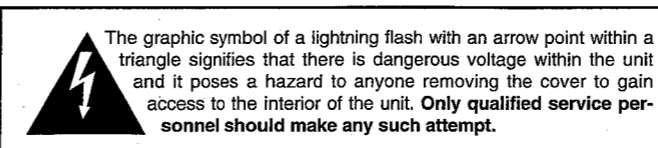

REAR PANEL CONNECTIONS

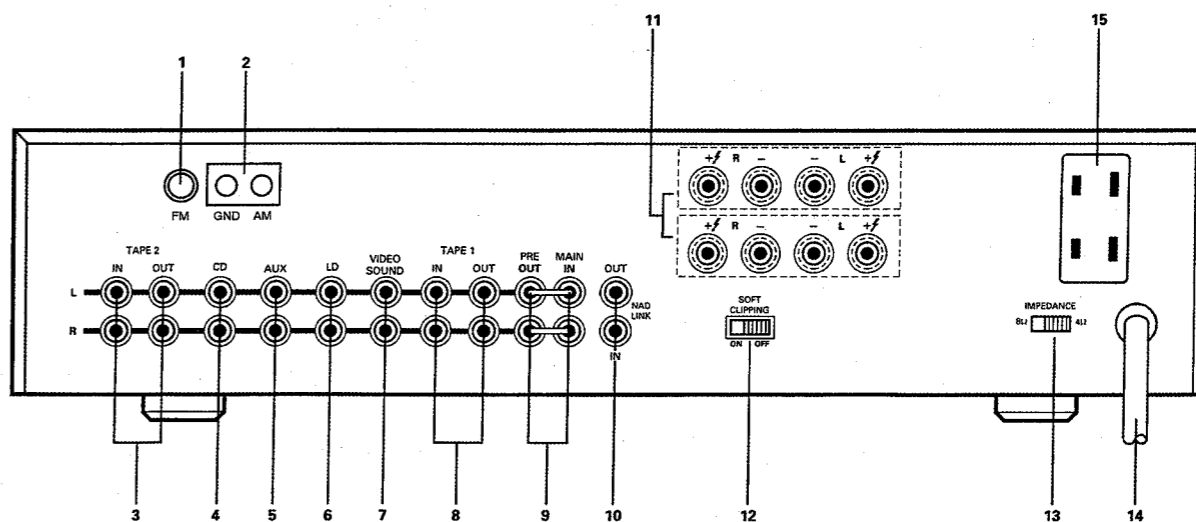

1. FM ANTENNA
2. AM ANTENNA
3. TAPE 2 IN/OUT
4. CD INPUT
5. AUX INPUT
6. LD INPUT
7. VIDEO SOUND INPUT
8. TAPE 1 IN/OUT
9. PRE OUT/MAIN IN
10. NAD LINK IN/OUT
11. SPEAKERS A AND B
12. SOFT CLIPPING SWITCH
13. IMPEDANCE SWITCH
14. AC POWER CORD
15. AC OUTLETS (ONLY IN 120V MODEL)

BLOCK DIAGRAM

SIGNAL FLOW DIAGRAM

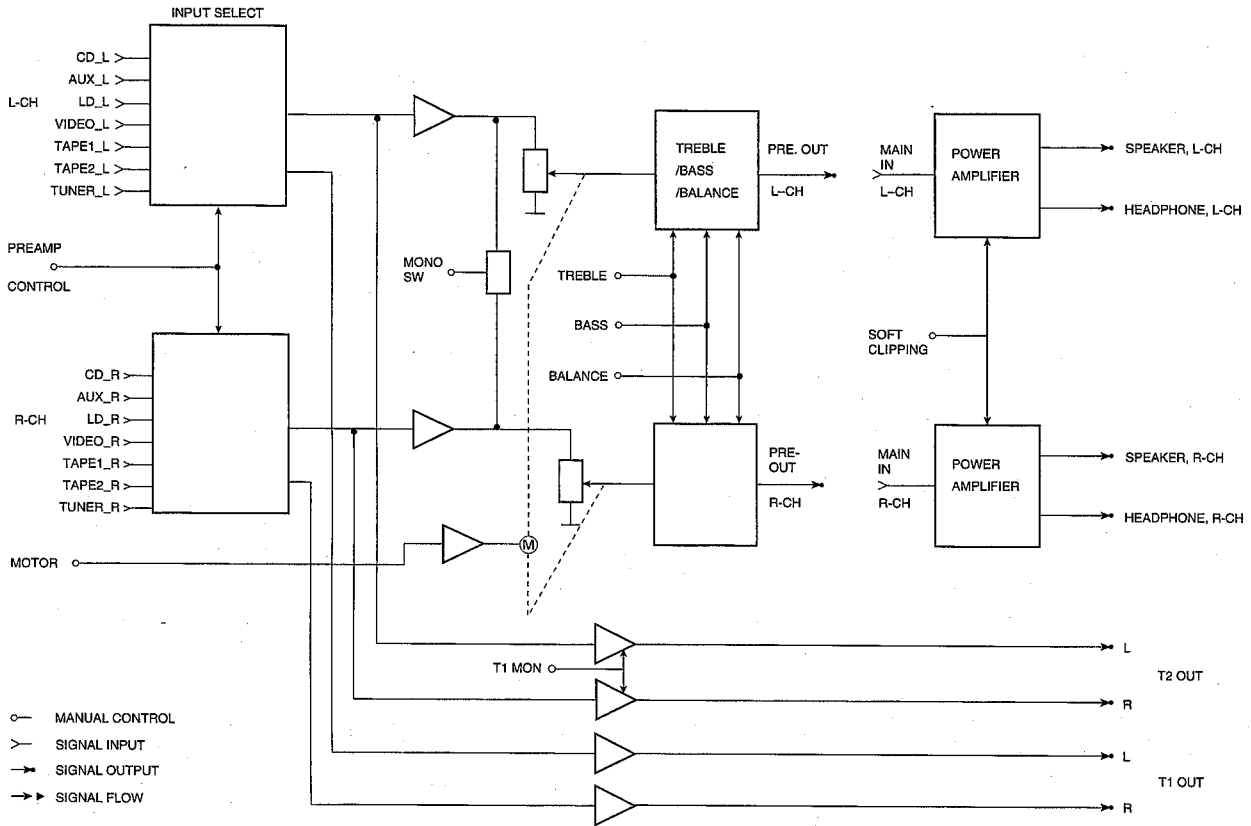

POWER SUPPLY

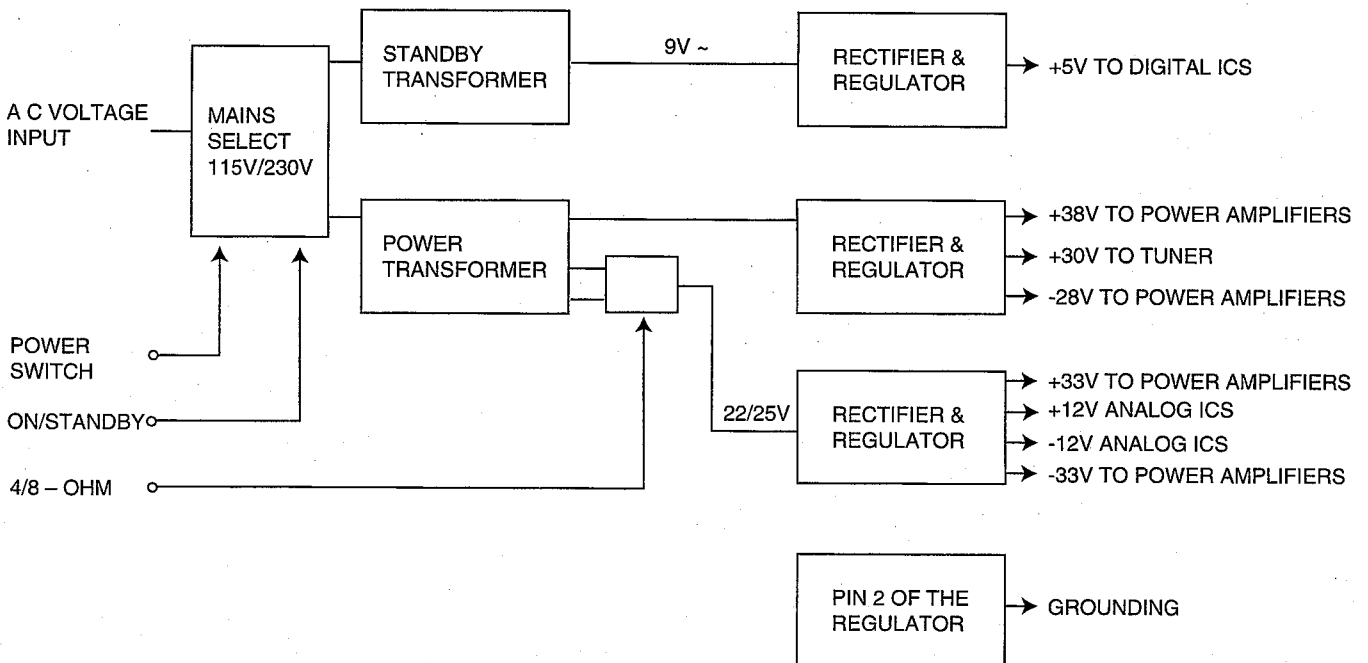

WIRING DIAGRAM

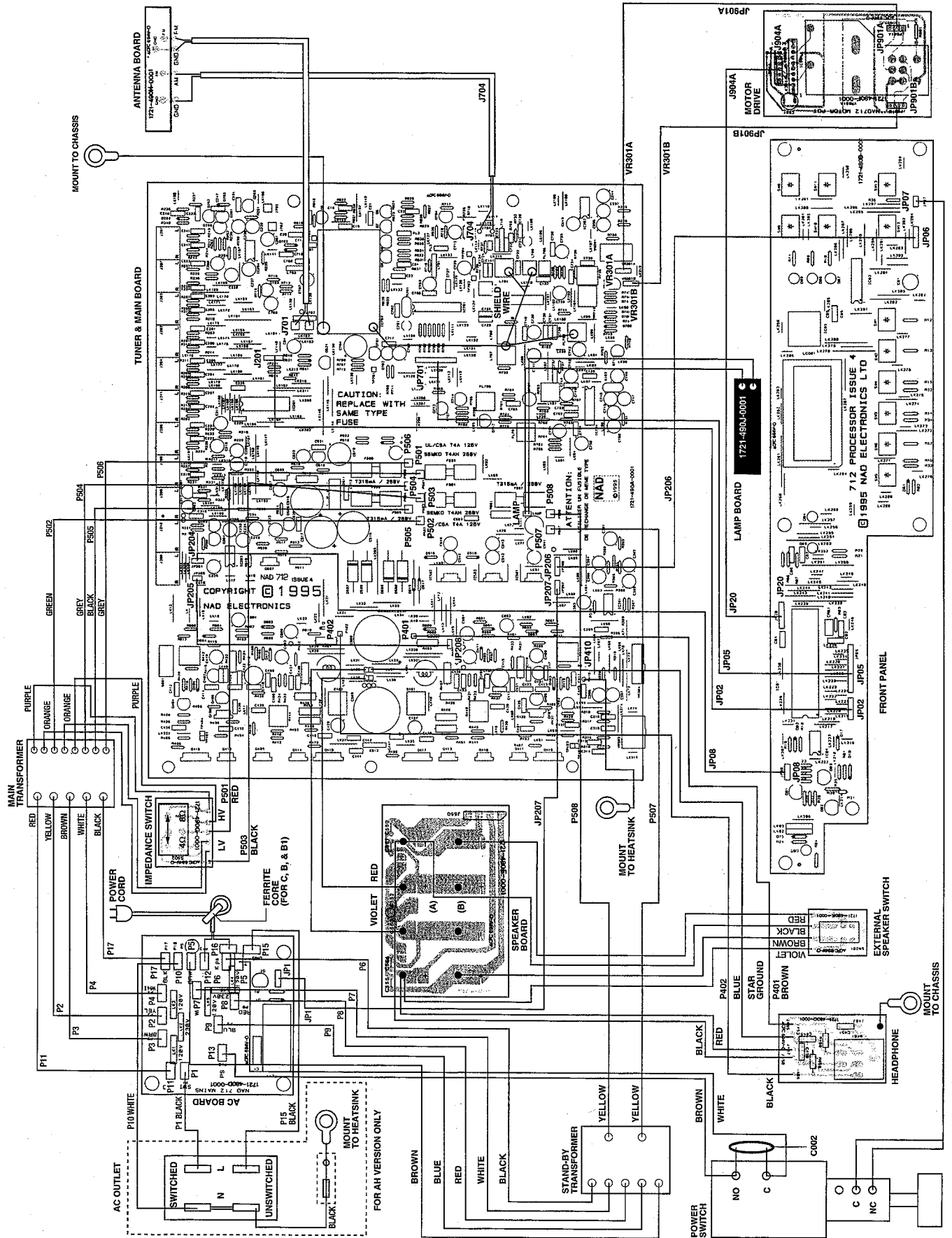

DISASSEMBLY INSTRUCTIONS

1. Remove machine screws M4.0 x 6.0 (① to ④) from the side panels.
Remove tapping screw 3.0 x 8.0 (⑤) from the back panel.
Refer to **Figure No. 1**.

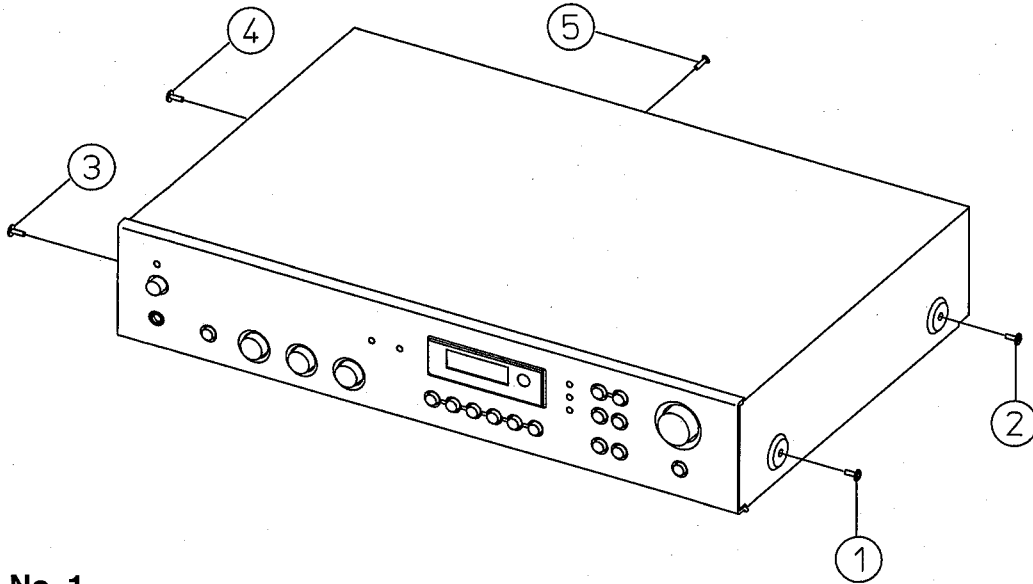

Figure No. 1.

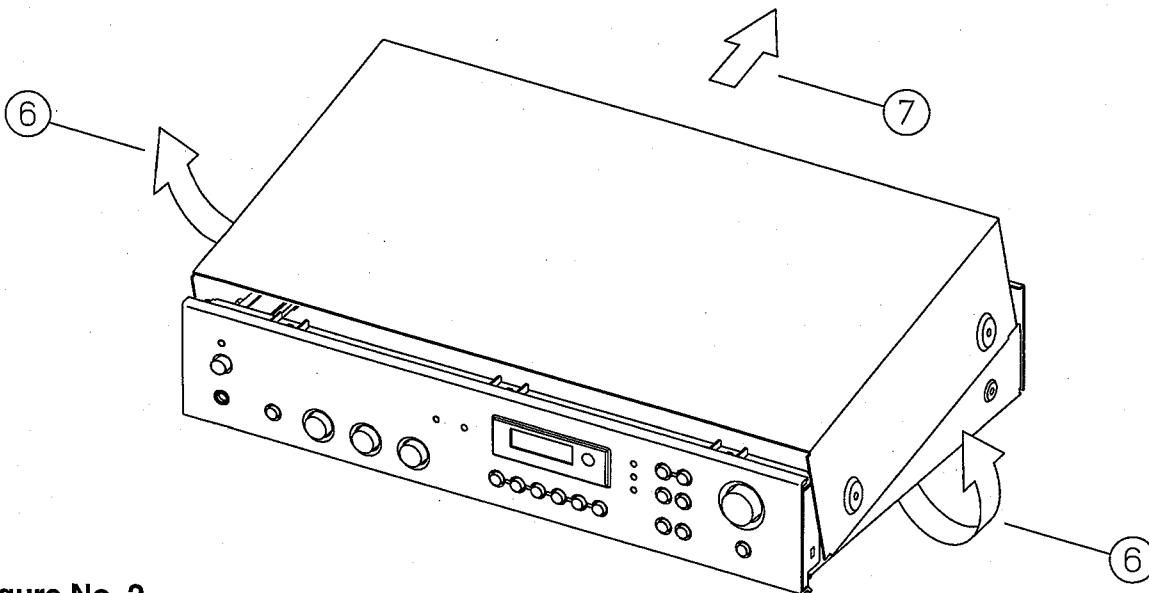
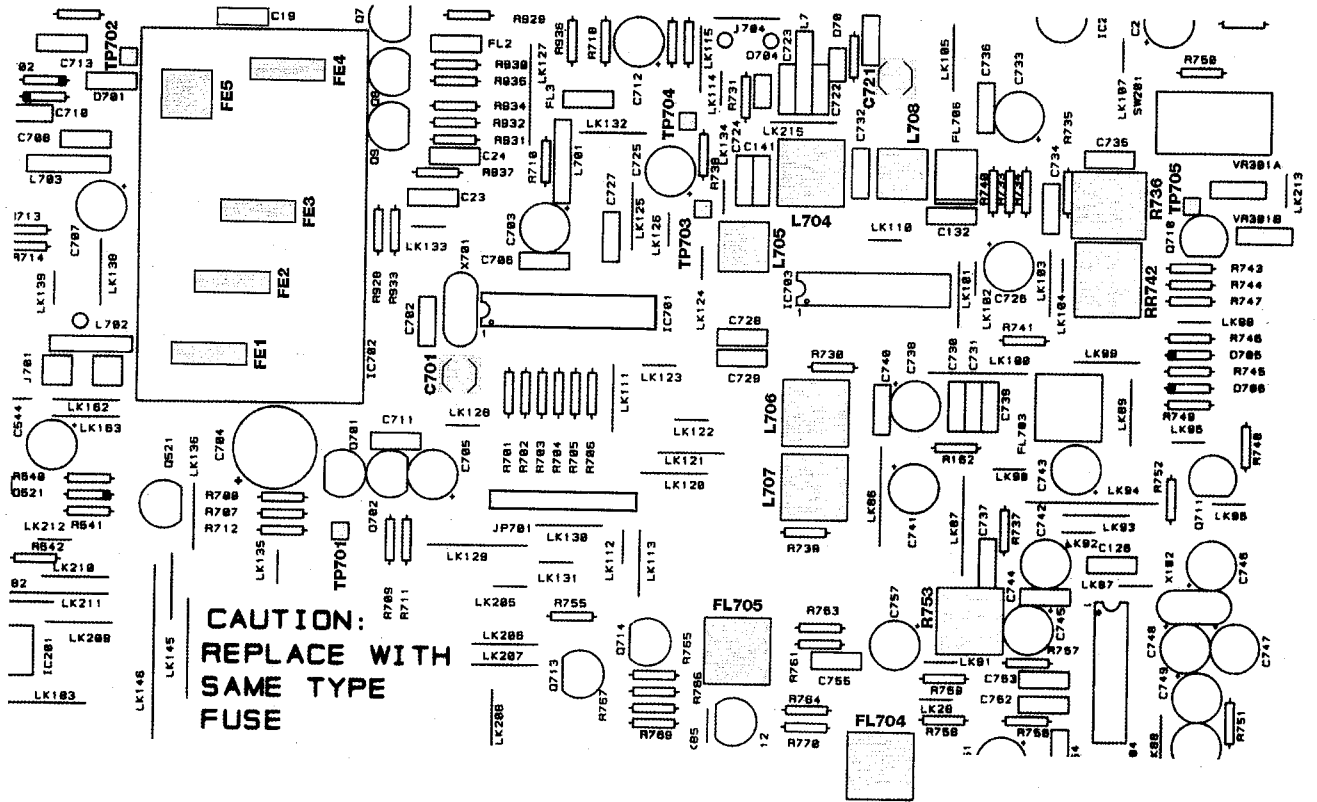

Figure No. 2.

2. Pull both sides of the TOP COVER slightly outwards, tilt approximately 35° and then move in the direction shown in **Figure No. 2**.

ADJUSTMENT POINTS DIAGRAM

1. TUNER



2. IDLE CURRENT

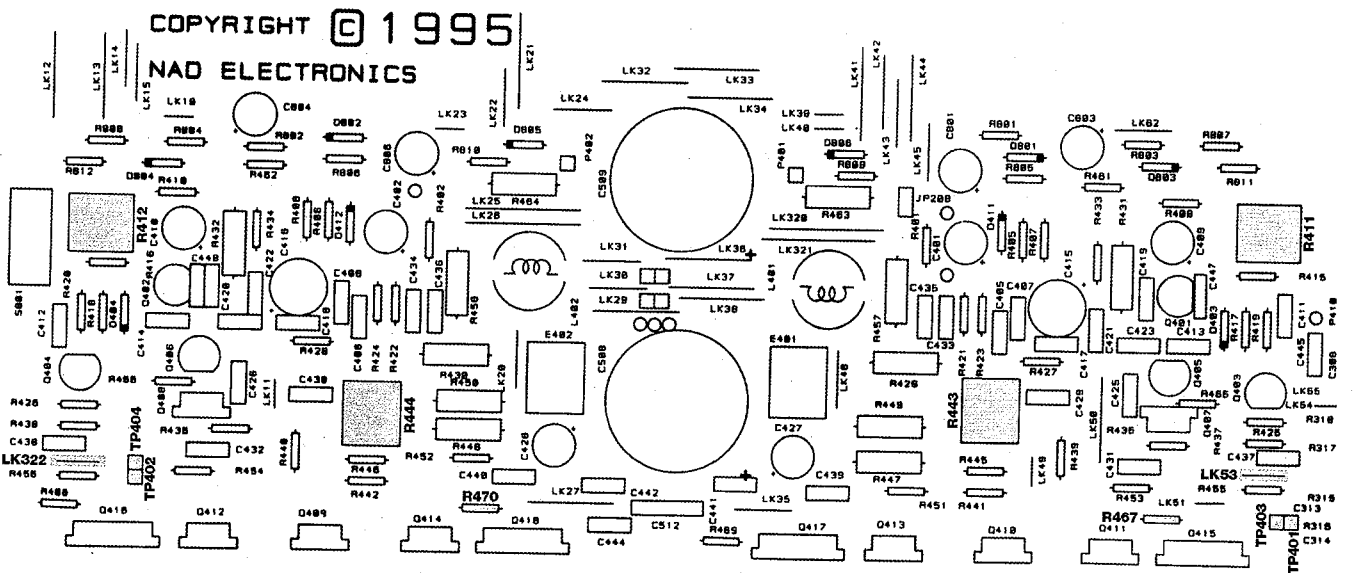

ALIGNMENT PROCEDURES

FM SECTION

AF MODULATION: 1 kHz, 75 kHz DEVIATION, MONO MODE
STORE FREQUENCY: 98 MHz, 87.5 MHz, 108 MHz, 90 MHz, 106 MHz
RF LEVEL: 75-ohm IMPEDANCE, OPEN CIRCUIT

OSCILLATION TUNING VOLTAGE

Connect DVM between TP701 & GND.

For A16 Front-end Module:

Tune to 87.5 MHz, adjust FE4 (osc coil) to read 3 ± 0.5 V.

Tune to 108 MHz, adjust FE4 (osc coil) to read 20.5 ± 0.5 V.

For G55 or G58 Front-end Module:

Tune to 87.5 MHz, adjust FE4 (osc coil) to read 1.6 ± 0.5 V.

Tune to 108 MHz, adjust FE4 (osc coil) to read 8.0 ± 0.5 V.

I.F.

Connect DVM between TP703 & TP704.

Apply 10.7 MHz, 90 dB μ via 1K-ohm to TP702.

Adjust L706 to read 0 ± 50 mV.

Adjust L707 for minimum distortion (THD).

Repeat adjustment until no further improvement.

SYNTHESIZER I.F. TRACKING

Disconnect 10.7MHz tap to TP702.

Maintain connection of DVM across TP703 & TP704.

Apply 98 MHz, 60 dB μ to antenna input.

Tune to 98 MHz.

Adjust C701 to read 0 ± 20 mV.

Fine adjust L707 for minimum distortion.

Repeat until no further improvement.

FRONT-END IF

Connect DVM between TP705 and ground.

Turn RR742 fully clockwise and R736 fully anti-clockwise.

Apply 98 MHz, 18 dB μ to antenna input.

Adjust FE5 to obtain minimum reading on DVM.

R.F.

Apply 98 MHz, 8 dB μ for AH or 22 dB μ for C, to antenna input.

Check THD.

If THD > 3%, adjust FE1, FE2 & FE3 in the front-end module with non-metallic tool for minimum THD.

Check THD at 90 MHz & 106 MHz with 9 dB μ input for AH, or 23 dB μ for C.

AUTO-SEARCH LEVEL

Turn R736 fully clockwise and RR742 fully anti-clockwise.

Set stereo modulator to L = R mode.

Apply 98 MHz, 18 dB μ to antenna input.

Adjust R736 until Center Tune LED just light.

Increase input level to 22 dB μ .

Adjust RR742 until FM stereo LED just light.

Check if auto-search works at 28 dB μ .

FM Stereo: 1kHz, 67.5kHz devi., 60dB μ V, Pilot signal 19kHz, 7.5kHz devi.

STEREO SEPARATION & PILOT SUPPRESSION

Set modulated signal to Left only.

Adjust R753 for minimum output at Right channel.

Set modulated signal to Right only.

Adjust R753 for minimum output at Left channel.

Repeat until readings are the same.

Turn off modulating signal, leaving the pilot tone.

Adjust FL704 and FL705 for minimum outputs on Right and Left channels respectively.

AM SECTION

For version conversion, press Tune UP while pressing Mode switch to toggle the AM steps between 9 kHz and 10 kHz.

AF MODULATION: 400 Hz, 30%

FOR AH VERSION, STORE FREQUENCIES 600, 1000, 1400 kHz.

FOR C & B VERSIONS, STORE FREQUENCIES 603, 999, 1404 kHz.

Connect 22 pF ceramic capacitor between signal generator and antenna terminal.

OSCILLATION TUNING VOLTAGE

Connect DVM between TP701 & GROUND.

Tune to 603/600 kHz.

Adjust L705 for 1.75 ± 0.05 V.

I.F.

Apply 999/1000 kHz, 35dB μ to antenna input.

Tune to 999/1000 kHz.

Adjust L708 for maximum output.

R.F.

Apply 603/600 kHz, 45dB μ .

Tune to 603/ 600 kHz.

Adjust L704 for maximum output.

Apply 1404/1400 kHz, 45dB μ .

Tune to 1404/ 1400 kHz.

Adjust C721 for maximum output.

Repeat until no further improvement.

AMPLIFIER ADJUSTMENT

IMPORTANT

*Speaker impedance switch should be in the 8 ohms position while adjusting the amplifier.
Reset switch after adjustment procedure is completed.*

1) Output Offset Voltage (No load, no input Signal)

Connect DC voltmeter across L channel speaker terminals.

Adjust R411 for 0 ± 30 mV reading.

Connect DC voltmeter across R channel speaker terminals.

Adjust R412 for 0 ± 30 mV reading.

2) Idle Current

Remove solder link in between TP 401 and TP403, or cut LK53.

Connect DC millivoltmeter at TP401 and TP403 (i.e. across R455, 1-ohm resistor).

Adjust R443 for 25-35mV reading on voltmeter.

Remove solder link in between TP 402 and TP404, or cut LK322.

Connect DC millivoltmeter at TP402 and TP404 (i.e. across R456, 1-ohm resistor).

Adjust R444 for 25-35 mV reading on voltmeter.

3) Final Adjustment

Leave power on for at least 5 minutes.

Repeat step 1

Repeat step 2

Replace solder link between T401 and T403 for left channel, and TP402 and TP404 for right channel, or reconnect LK53 and LK322.

MAIN BOARD & TUNER

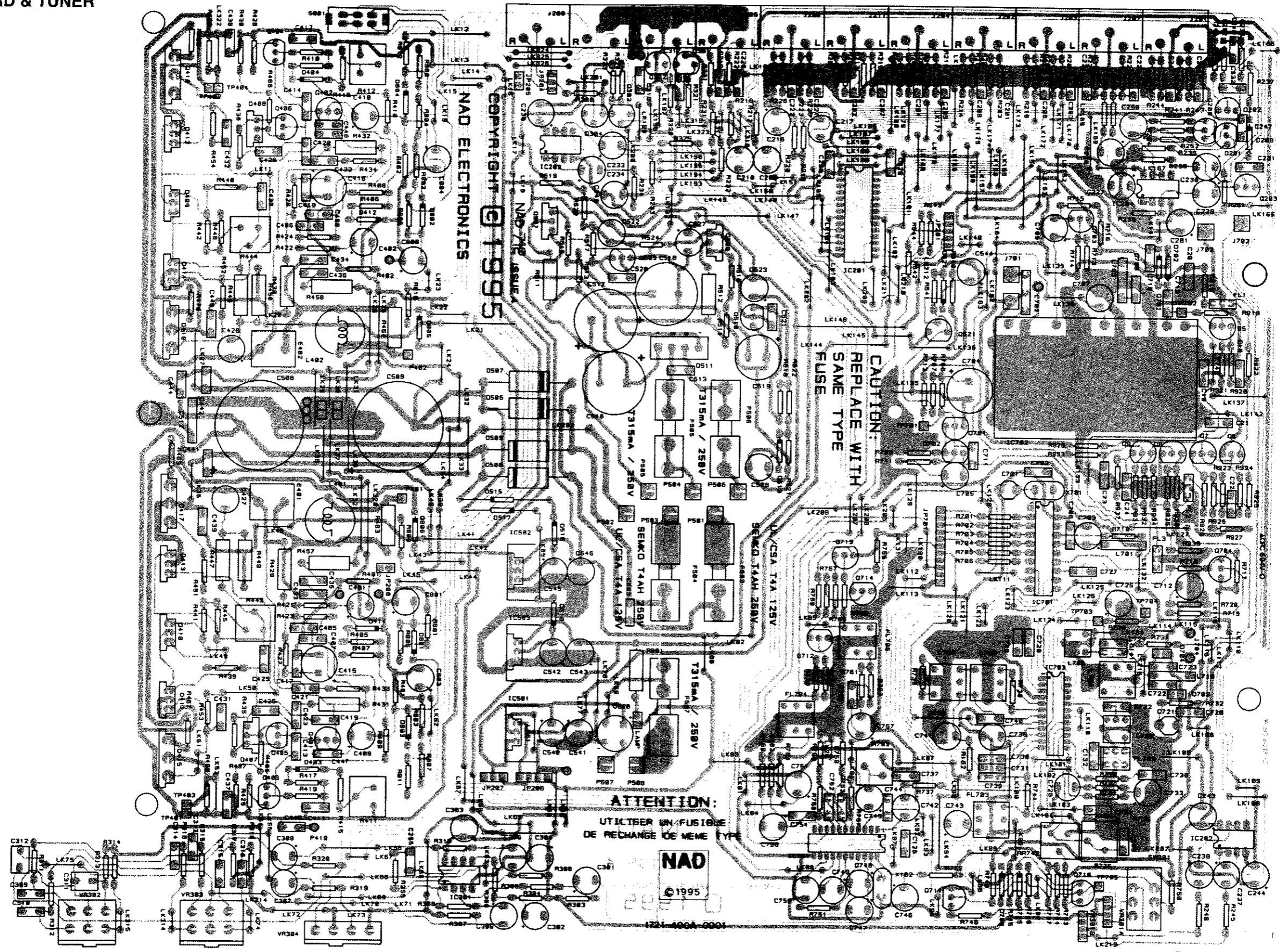

©1995
NAD ELECTRONICS
NAD 716 ISSUE

CAUTION:
REPLACE WITH
SAME TYPE
FUSE

ATTENTION:
UTILISER UN FUSIBLE
DE RECHANGE DE MEME TYPE

NAD
©1995

SCHEMATIC DIAGRAM

PSU & MAINS

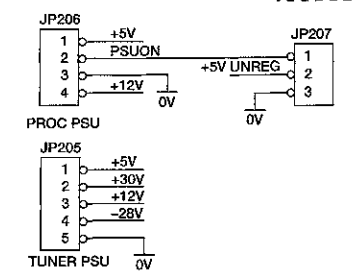
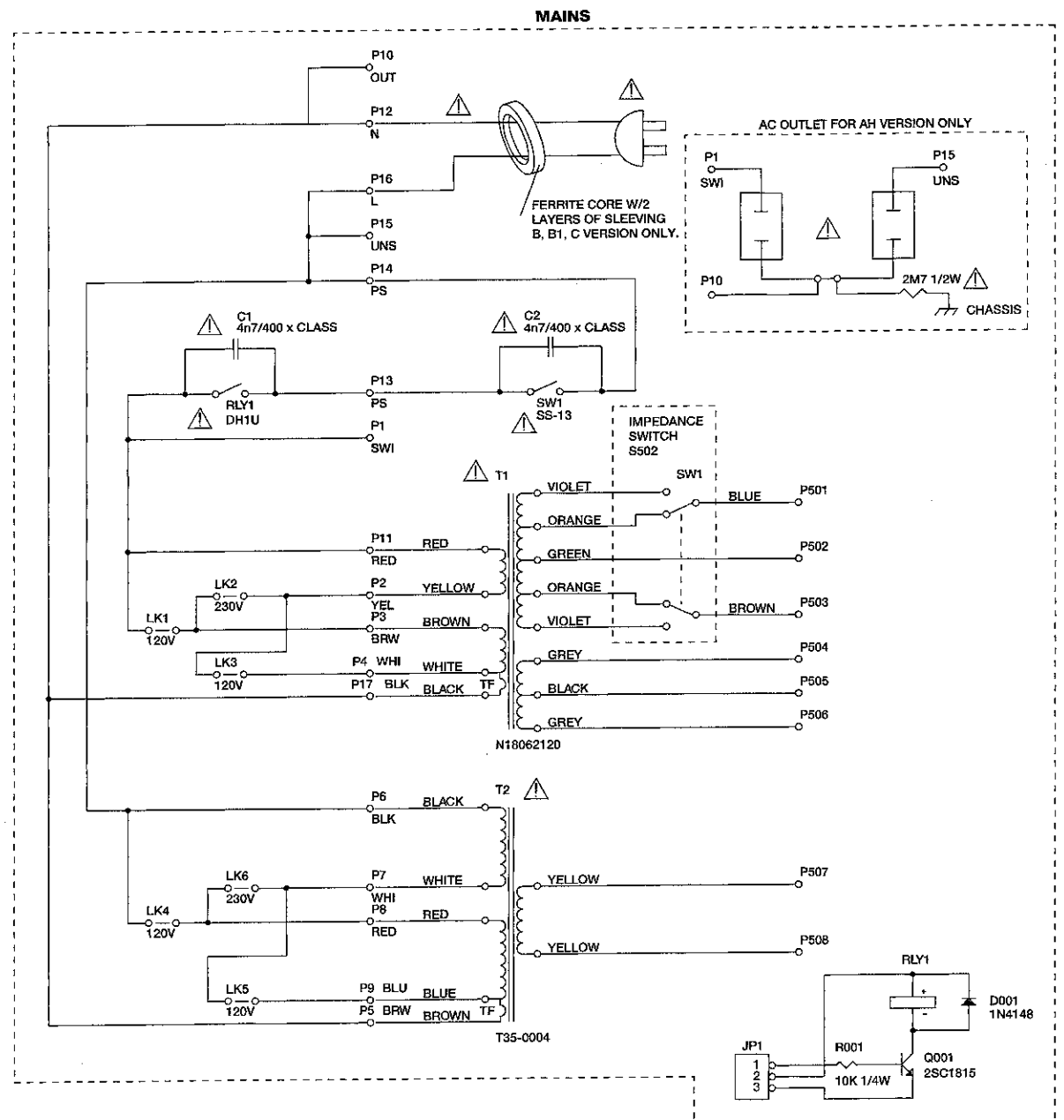
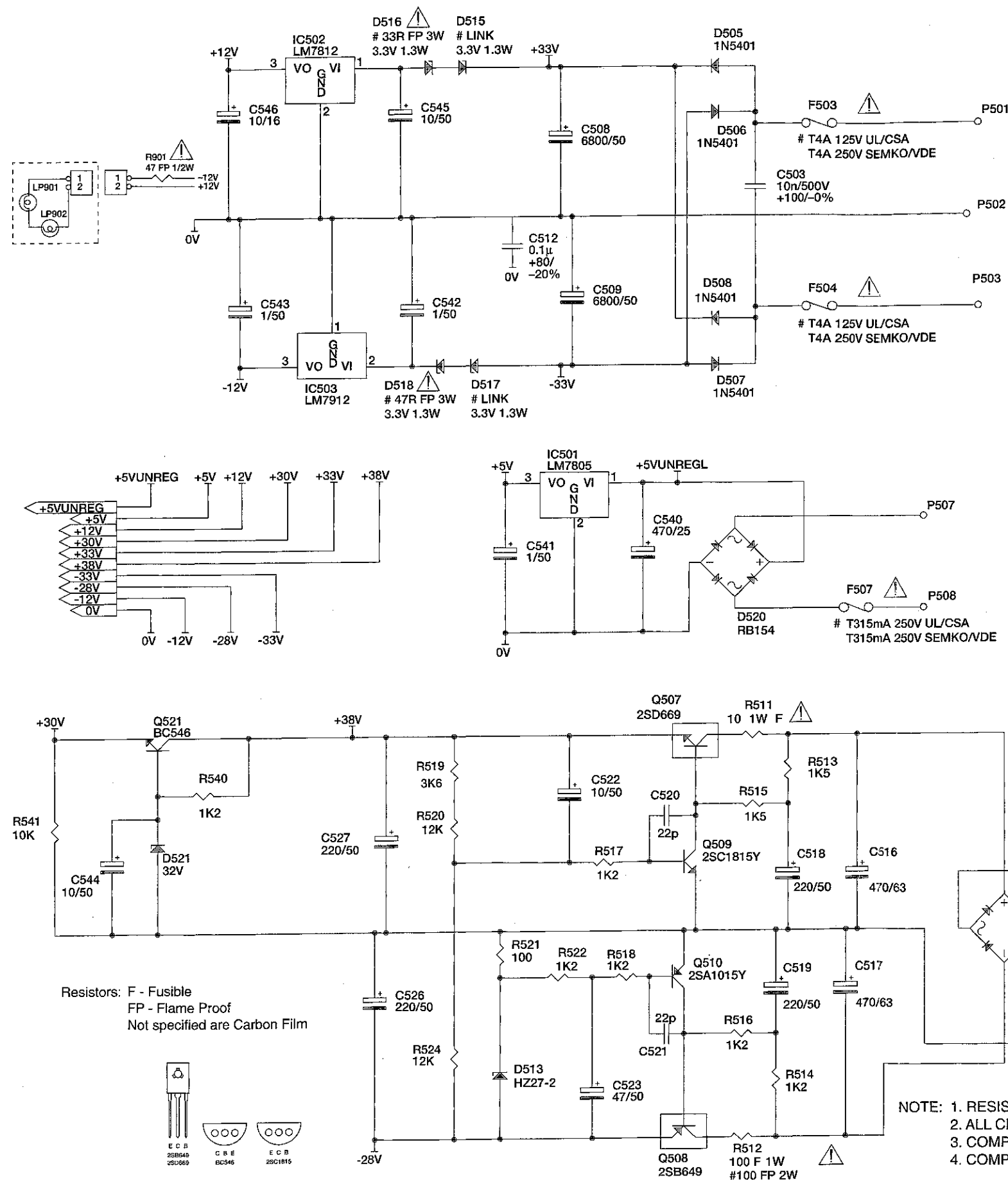

INPUT, SPEAKER & HEADPHONE

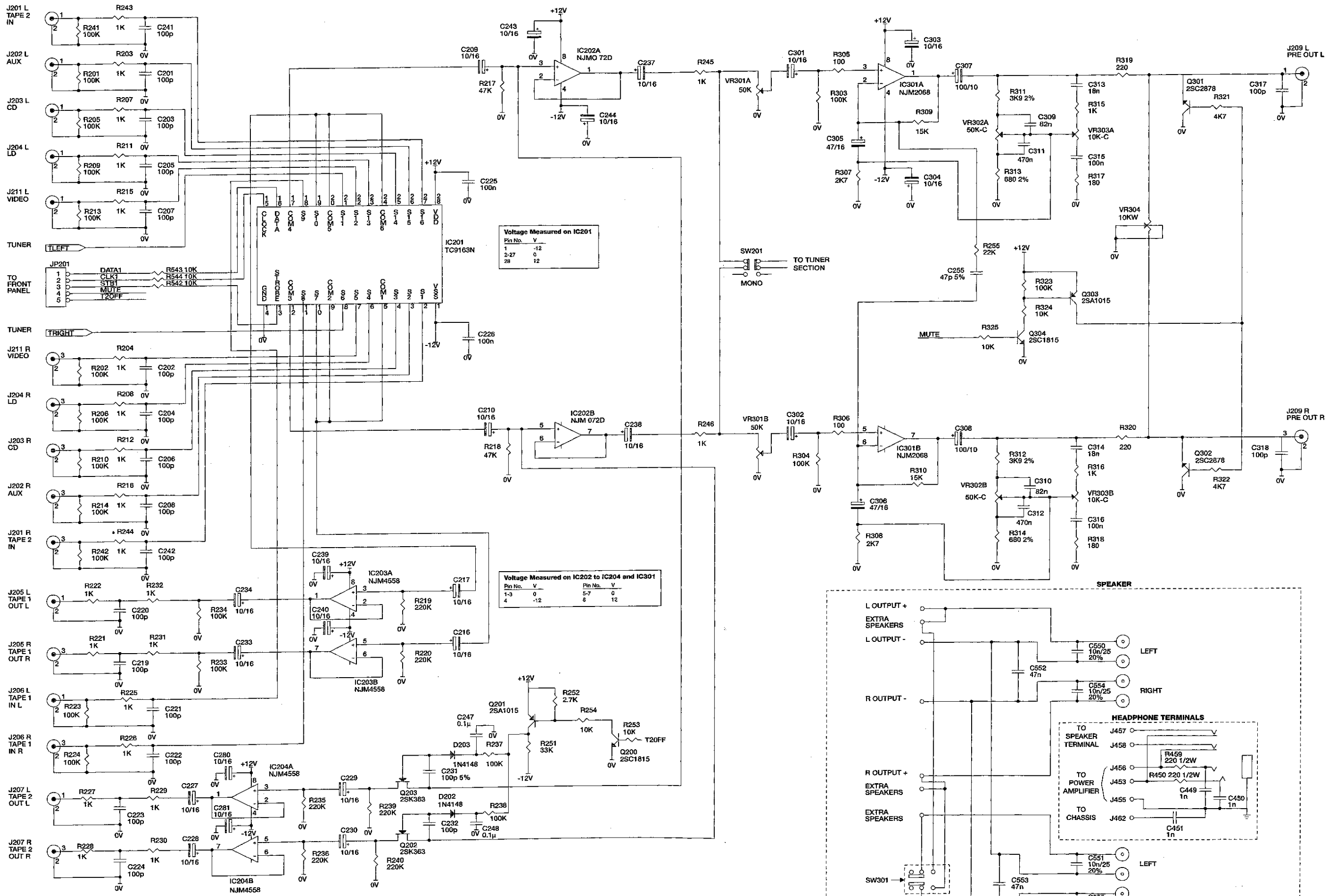

Voltage Measured on IC201

Pin No.	V	Pin No.	V
1	-12	12	
2-27	0		
28	12		

Voltage Measured on IC202 to IC204 and IC301

Pin No.	V	Pin No.	V
1-3	0	5-7	0
4	-12	8	12

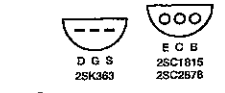
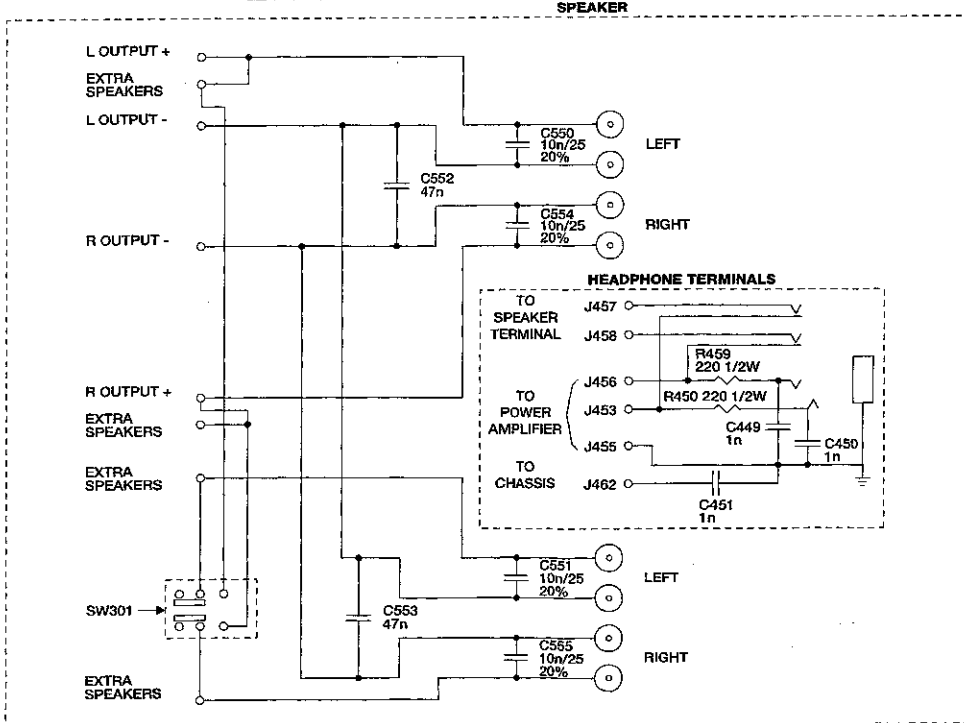

NOTE: 1. RESISTORS, UNLESS OTHERWISE SPECIFIED, ARE 1/4 WATT.
2. ALL CERAMIC CAPACITORS, UNLESS OTHERWISE SPECIFIED, ARE 50V, 10%.

AMPLIFIER

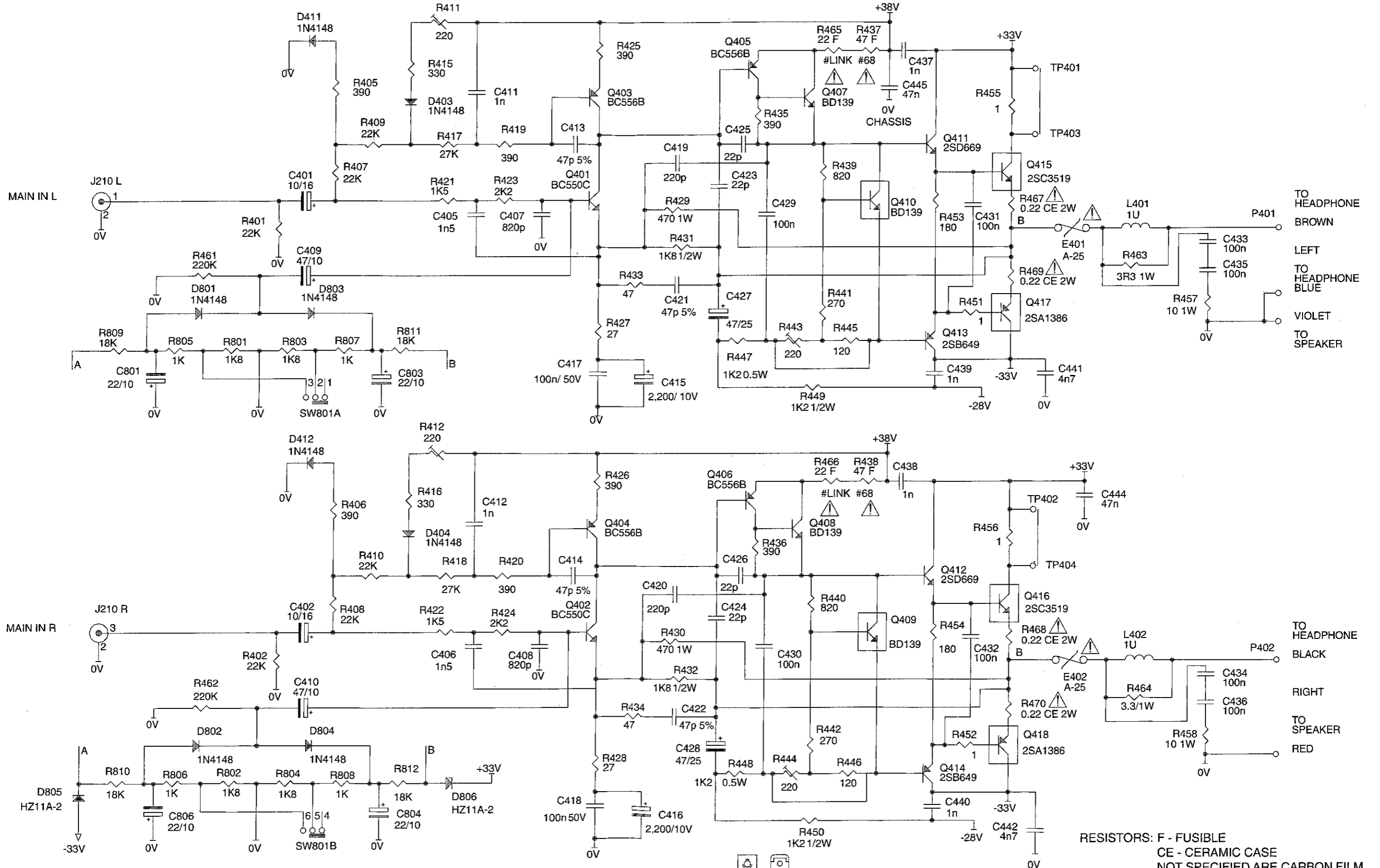

RESISTORS: F - FUSIBLE
 CE - CERAMIC CASE
 NOT SPECIFIED ARE CARBON FILM

- NOTE: 1. RESISTORS, UNLESS OTHERWISE SPECIFIED, ARE 1/4 WATT.
 2. ALL CERAMIC CAPACITORS, UNLESS OTHERWISE SPECIFIED, ARE 50V, 10%.
 3. COMPONENTS MARKED WITH "#" ARE AH VERSION ONLY.
 4. COMPONENTS MARKED WITH "Δ" ARE SAFETY CRITICAL PARTS.

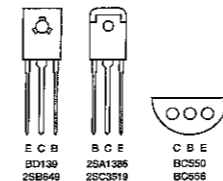

TUNER

Voltage Measured on IC701 LM7000

Pin No.	FM	AM	Pin No.	FM	AM
1	1.62	1.62	11-12	0.07	0.07
2-4	0	0	13	0.07	1.80
5	4.95	0	14	2.78	0.04
6	4.95	4.95	15-16	4.95	4.95
7	0	0	17	1.19	1.19
8	0.25	10.66	18	1.57	1.83
9	11.74	0.23	19	0	0
10	0.91	0.99	20	1.30	1.30

Voltage Measured on IC703 LA1266

Pin No.	FM	AM	Pin No.	FM	AM
1	2.54	1.05	12	3.14	3.17
2-3	0	1.05	13	0	0
4	0	0	14	1.54	1.52
5	11.61	11.64	15	1.54	1.46
6-7	11.58	11.58	16-17	0	0
8	10.30	10.30	18	2.54	1.08
9	4.07	3.81	19	1.53	1.44
10	2.46	2.65	20	0	11.84
11	2.88	2.30	21-23	4.0	3.68
			24	3.22	2.90

Voltage Measured on IC704 LA3401

Pin No.	FM	AM	Pin No.	FM	AM
1-4	3.20	3.20	14	5.0	0.05
5	6.27	6.27	15	0	0
6	3.26	3.26	16	2.81	2.81
7	3.20	3.20	17	8.15	9.50
8	6.32	6.32	18	4.76	5.20
9	3.20	3.20	19	2.81	5.20
10	2.50	10.66	20	6.44	7.48
11-12	0	0	21	2.0	2.0
13	10.41	10.41	22	11.66	11.66

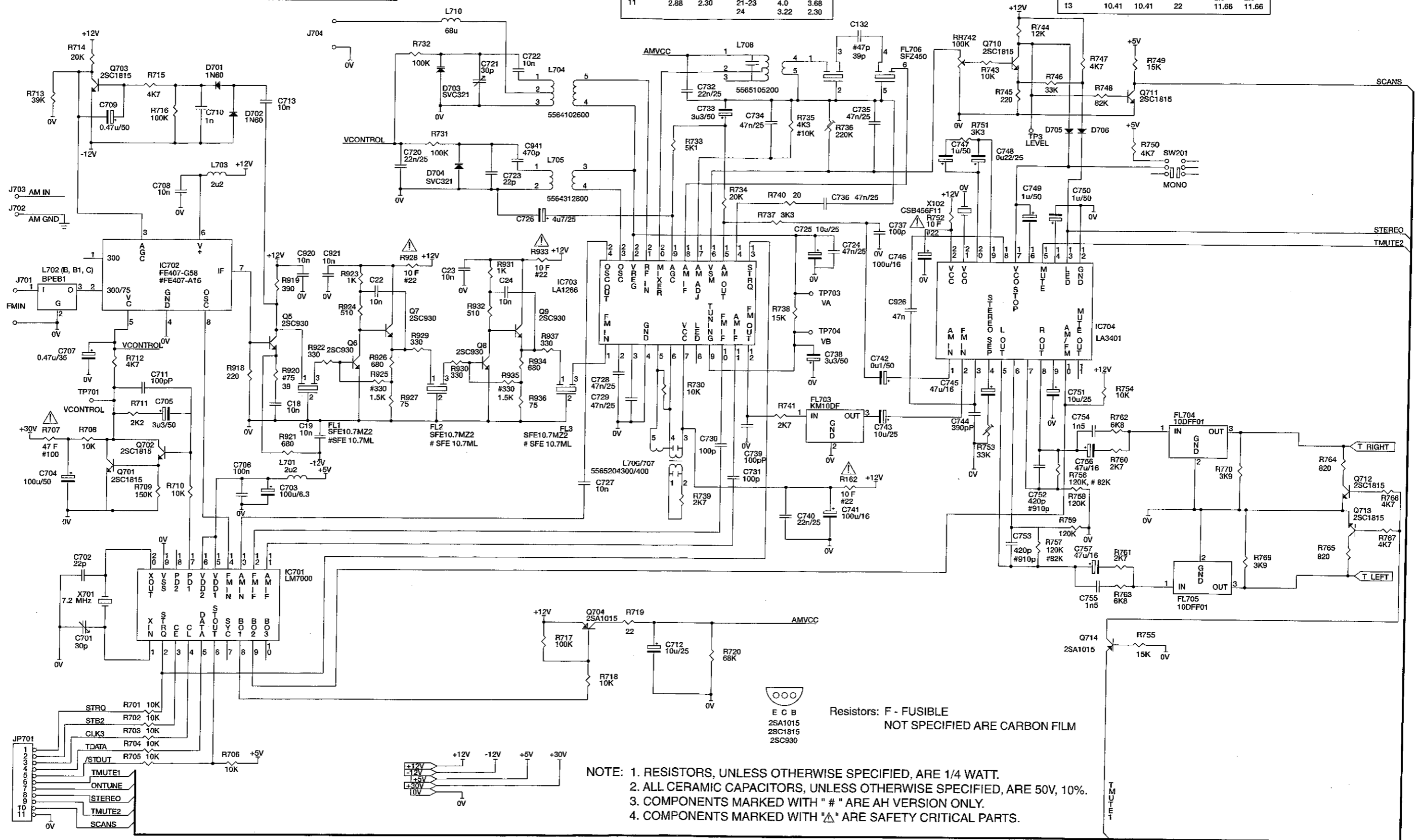

FRONT PANEL & MOTOR POT

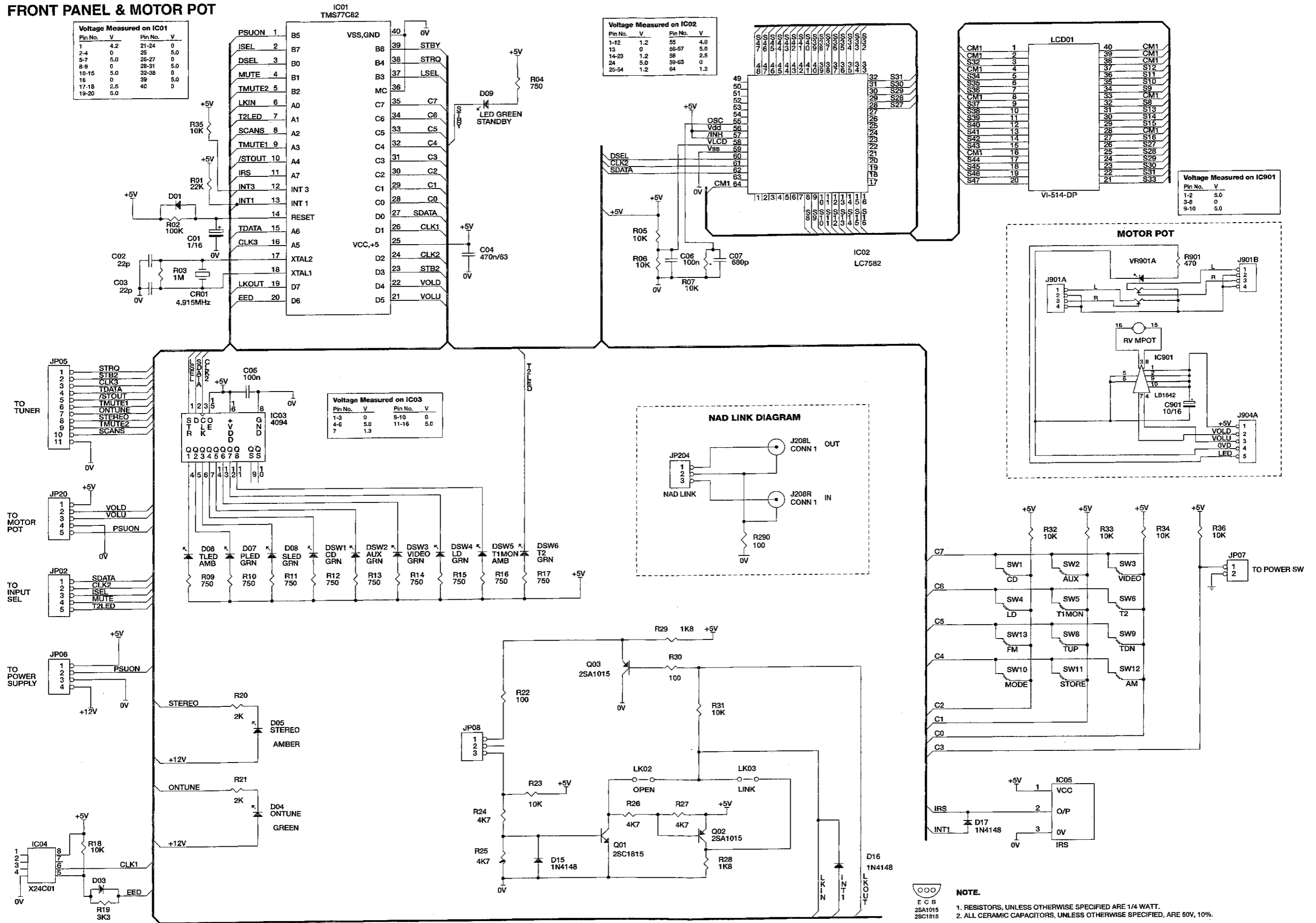

IC BLOCK DIAGRAM

IC201: TC9163N

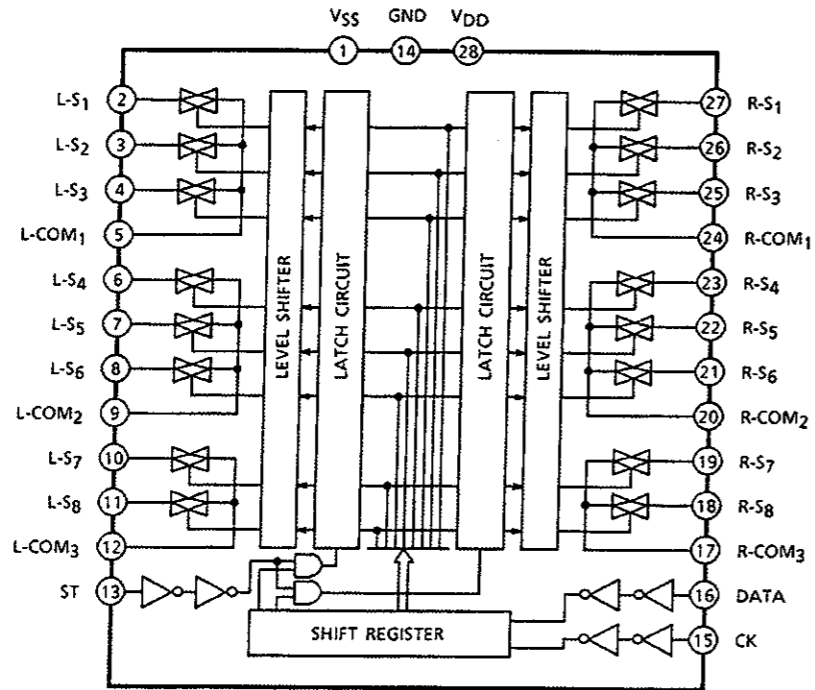

IC202: NJM072D

IC203, IC204: NJM4558, IC301: NJM2068

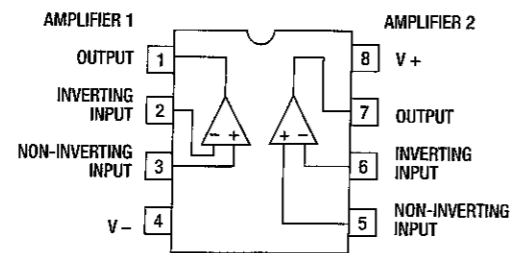

IC01: TMS77C82

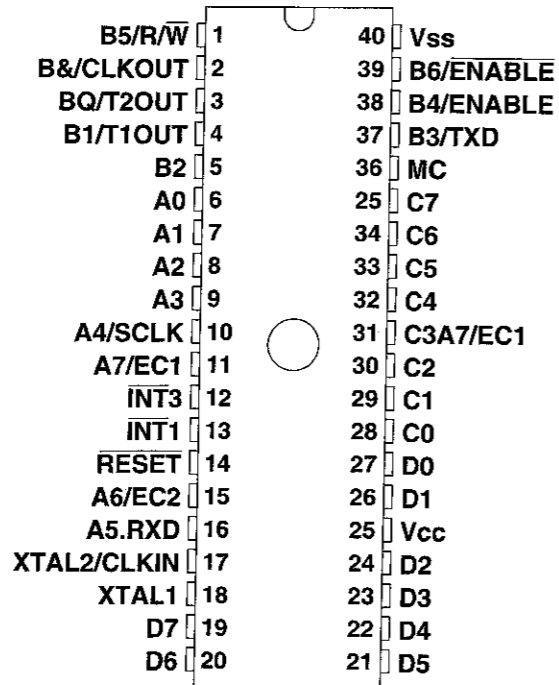

IC701: LM7000 (BLOCK DIAGRAM)

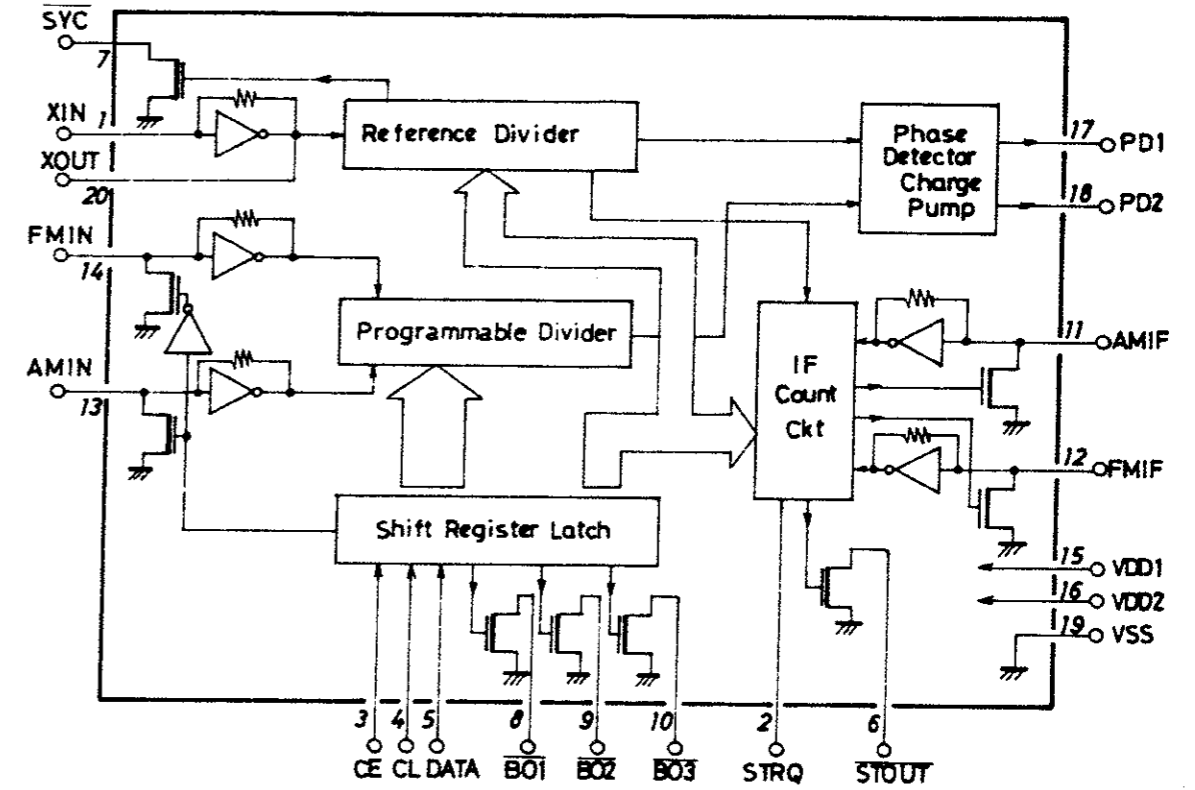

IC703: LA1266 (BLOCK DIAGRAM)

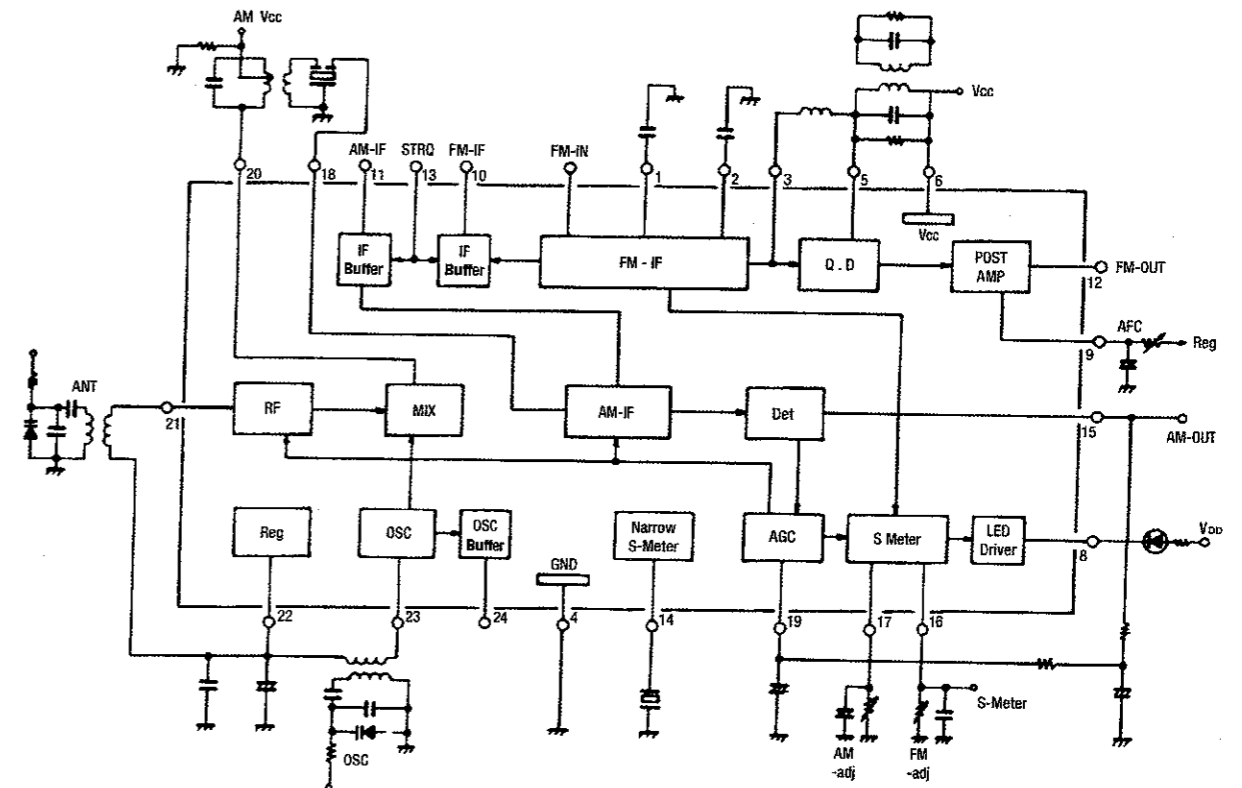

IC704: LA3401

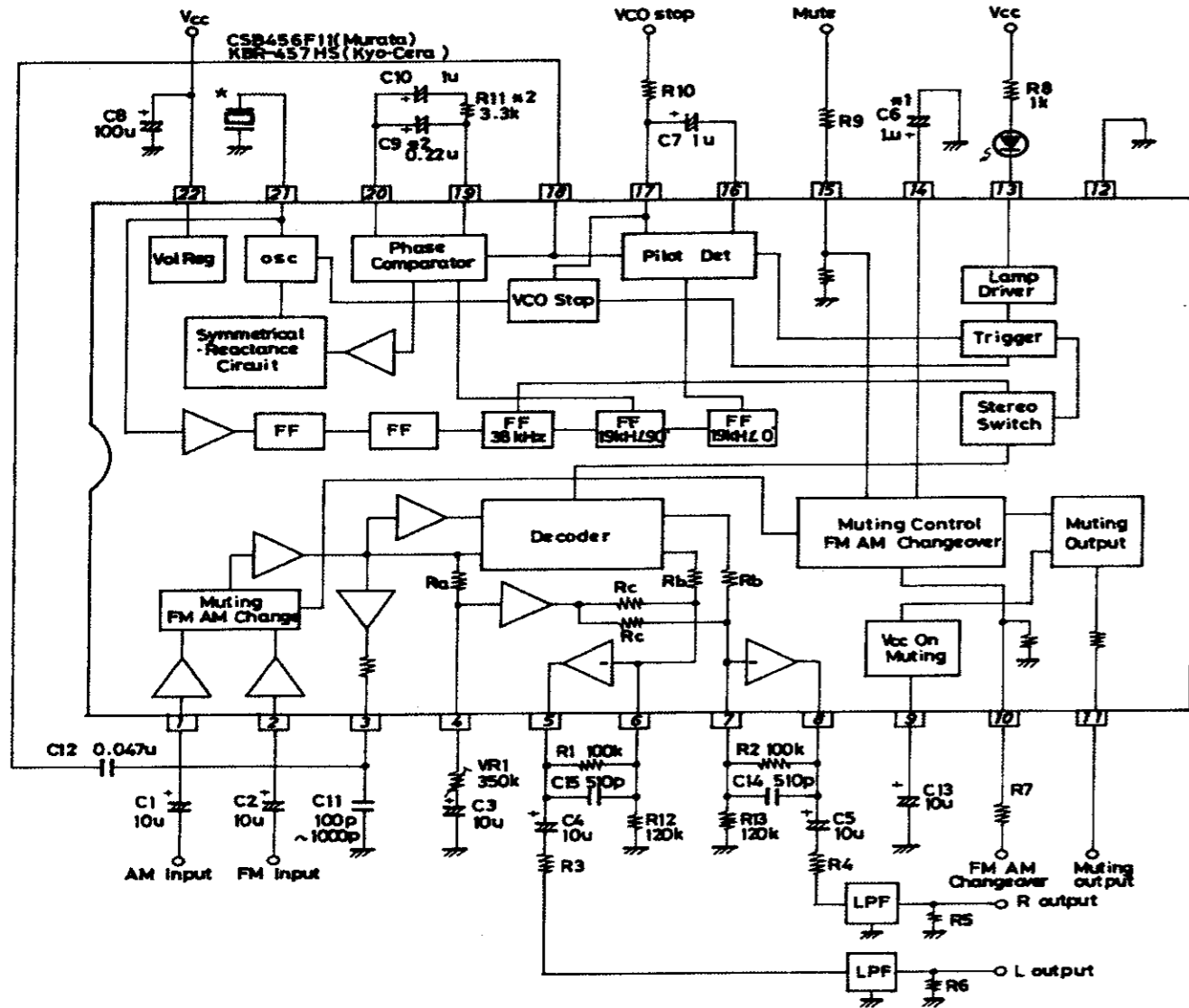

IC02: LC7582A (BLOCK DIAGRAM)

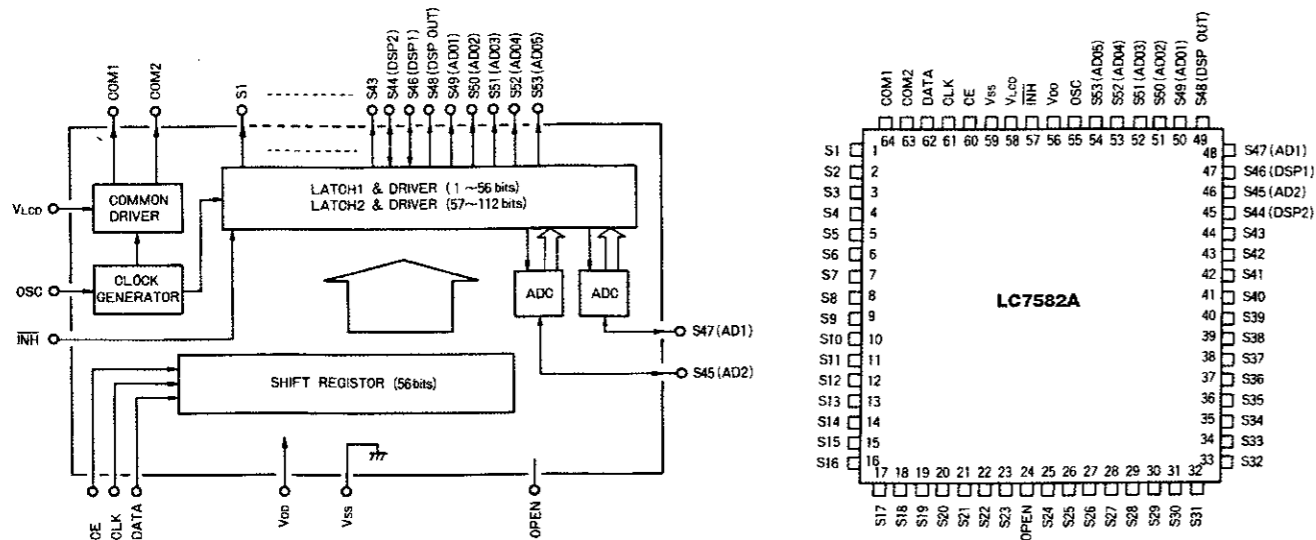

IC03: MC14094BCP

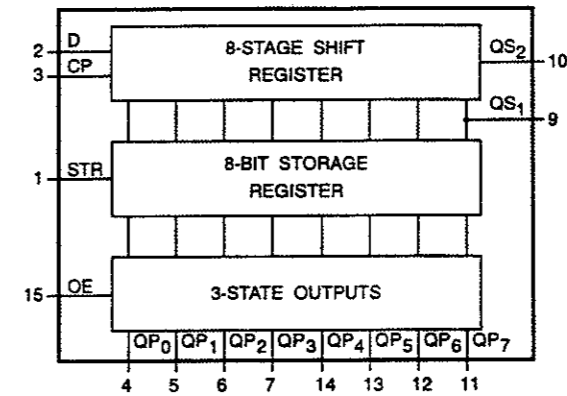

IC901: LB1642

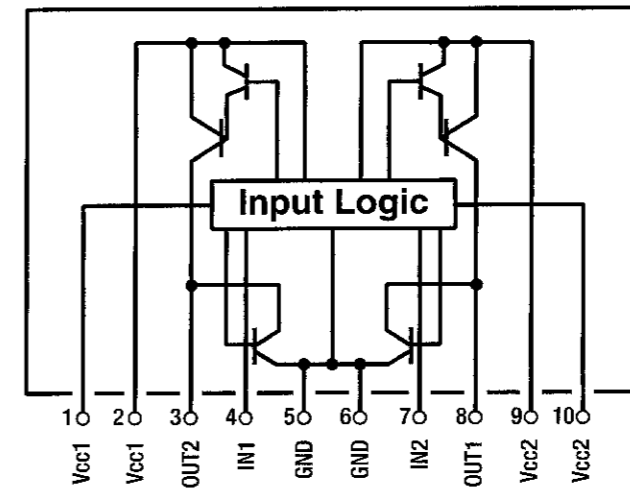

Q710: X24C01P

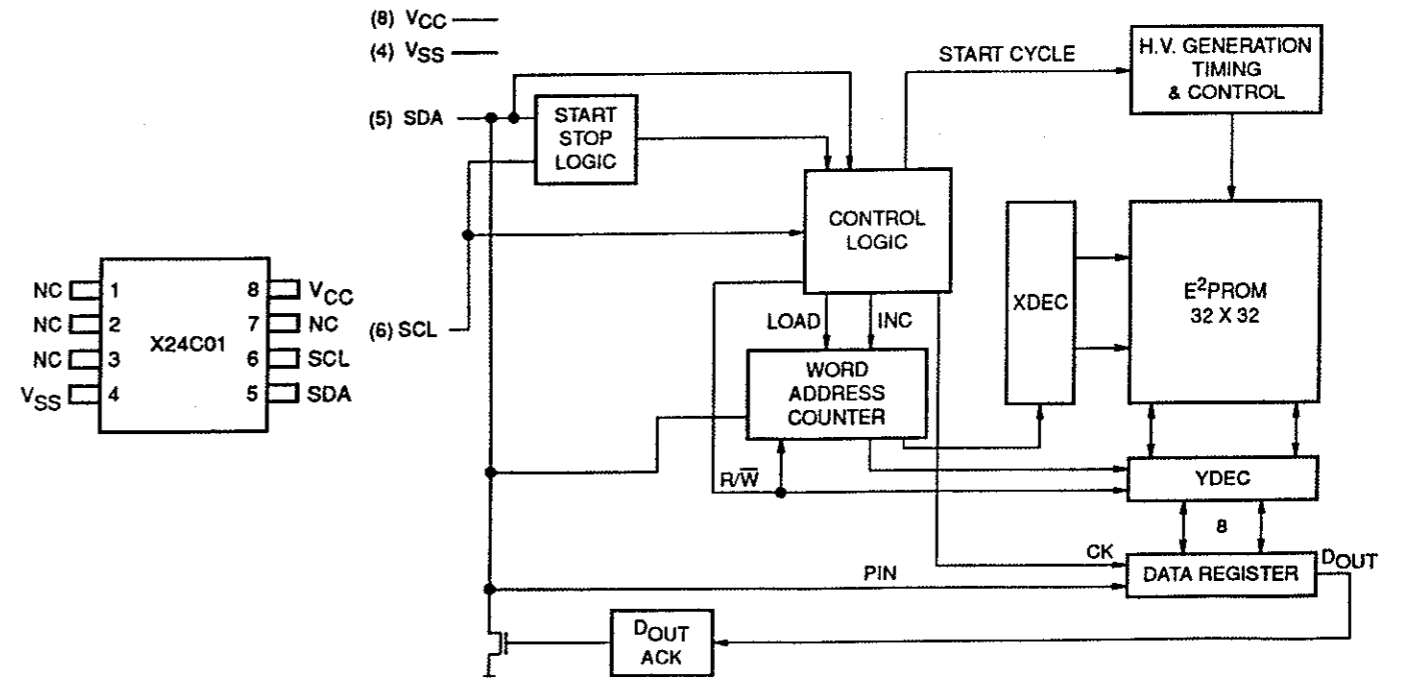

EXPLODED VIEW PARTS LIST

<u>Item</u>	<u>Part No</u>	<u>Description</u>	<u>Qty</u>
0001	N14630511-0	FASCIA	1
0002	N14023820-0	SUBFASCIA	1
0003	1402-3720-0	CHASSIS	1
0004	N14023810-0	BASE COVER	1
0005*AH	1402-4012-0	REAR PANEL	1
0005*B,B1,C	1402-3833-0	REAR PANEL W/SS	1
0006	N14023840-0	TOP COVER	1
0007	N2437510B-0	DIA 9.5 POWER BUTTON	1
0008	N14023460-0	35MM KNOB SKIN	1
0009	N24377601-0	35MM KNOB CORE	1
0010	N24377706-0	35MM KNOB LENS	1
0011	N37146111-0	WINDOW LENS	1
0012	N24376001-0	LONG BUTTON 8.0MM	2
0013	N37145706-0	LED LENS	6
0014	N24377301-0	SINGLE BUTTON	6
0015	N21502171-1	LIGHTBOX (WHITE REFLECTOR)	1
0016	N24375701-1	KNOB 18.5MM (BASS,TREBLE,BALANCE)	3
0017	N41520041-0	POINTER	3
0018	N37143306-0	BUTTON LENS	6
0019	N24377401-0	SINGLE LENS BUTTON	6
0020	4152-0791-0	PCB SUPPORT CBS-18R 18MM HIGH	4
0021	N54000831-0	HEATSINK 20MM-HIGH HOLE	3
0022	△ N41519461-0	STRAIN RELIEF BUSHING	1
0023	N41321021-0	U-SHORTING BAR 18MM PI	2
0024	N41519431-0	PLATE SWITCH 0.5 PVC	1
0025*AH	N21036004-0	SPK TERM W/O PLUG	2
0025*B,B1,C	2103-6604-1	SPK TERM W PLUG	2
0026*AH	N21070641	ANT-TERMINAL F-TYPE	1
0026*B,B1,C	N21070681	ANT TERMINAL DIN-TYPE	1
0101*AH △	N70093100-1	AC CORD	1
0101*B △	N70095110-1	AC CORD	1
0101*C △	N70093110-1	AC CORD	1
0101*B1 △	N70091190-0	AC CORD	1
0102*AH △	2103-7701-2	AC OUTLET	1
0103*AH △	N41519941-0	AC OUTLET COVER PLATE	1
0201	2954-3008-0000	TAPPING 3X8MM B-TITE (YEL.ZN)	22
0202	2954-3008-3000	TAPPING 3X8MM B-TITE (BLK.ZN)	41
0203	2900-4006-3010	M4X0.5PX6MM W/FLAT WASHER	4
0204	2842-3367-0	METAL WASHER ID=3.3 OD=6.7	4
0205	2904-3006-0000	SCREW M3X6 MM (YEL.ZN)	6
0207	2954-3006-0000	TAPPING 3X6MM B-TITE (YEL.ZN)	6
0208	2904-3010-0000	SCREW M3X10MM (YEL.ZN)	4
0209	2950-3008-0000	TAPPING 3X8 B-TITE PH (YEL.ZN)	4
0210	2601-2608-0601	FIBRE WASHER M2.6 0.8T OD=6	3

<u>Item</u>	<u>Part No</u>	<u>Description</u>	<u>Qty</u>
0213	2904-3004-4000	SCREW M3X4 MM (WHI.ZN)	2
0302	N3714110B-0	LEE FILTER NO217 BLUE DIFFUSER	1
0303	3714-640B-0	LEE FILTER NO202 1/2 CT BLUE	3
0304	N37141006-0	DIFFUSER LENS 1MM PC SHEET	1
0306	2944-3006-3000	SCREW D3X6 S-TITE BH,BK	2
0307	2900-4006-3010	M4X0.5PX6MM W/FLAT WASHER	4
0320	5400-1081-1	HEAT SINK EXTRUSION	2
0321	5400-1121-1	HEAT SINK BAR	1
0330 △	N16600640-0	SHRINKABLE TUBE ID=30 UL/CSA	1
0405	N41519371-1	RUBBER FOOT 14.8MM HIGH	4
0406*B,B1,C	1808-0130-0	FERRITE CORE D19 X T/O	1
FH503-FH507	4131-9131-0	FUSE HOLDER 6.5MM PITCH	10
J101	N21039102-0	2P RCA JACK 1020-060 ORG	1
J201, J209	N21037604-2	4P RCA JACK R/W NI HSP-204V-01	2
J203, J211	N21038506-2	6P RCA JACK R/W NI HSP-206V-01	2
T001 △	N18062120-1	MAIN TRANSFORMER	1
T002 △	N18062096-0	STANDBY TRANSFORMER	1
VR302	N47503676-0	VR-BASS 2X50KC W/WASHER & NUT	1
VR303	N47503646-0	VR-TRE 2X10KC W/WASHER & NUT	1
VR304	N47503656-0	VR-BAL 1X10KW W/WASHER & NUT	1
S801	N52003131-0-01	2P2T SLIDE SW 3.5T22KYGX	1
SW201	N52003121-0-01	2P2T ALPS SPUN W/O FRAME	1
SW301	N52002081-0-01	PUSH BUTTON SW 2P2J ALPS 1 KEY	1

NOTE: - The components identified by △ mark are critical for risk of fire and electrical shock. Replace only with part number specified.

- <*AH > : USA, Canadian model only.
- <*B > : UK model only.
- <*B1 > : Australian model only.
- <*C > : European model only.

ELECTRICAL PARTS LIST

<u>Reference No</u>	<u>Part Number</u>	<u>Description</u>
<u>SWITCH ASSEMBLY</u> PC BOARD	MI-21490G-01-S	SWITCH ASSEMBLY
SWITCH S502	N52003031-0-01	SLIDE SWITCH 5.2T22SS28G10
<u>MOTOR POT ASSEMBLY</u> PC BOARD	MI-21480F-01-S	MOTOR POT ASSEMBLY
CAPACITOR C901	157D-106M-5-II	CE 16V 10 μ F 20%
IC IC901A	N31303410-0	IC LB1642 SANYO MOTOR DRIVER
VARIABLE RESISTORS VR901A	4750-3860-0	MOTOR POT 50KAX2 VOL
<u>HEADPHONE ASSEMBLY</u> PC BOARD	MI-21490C-01-S	HEADPHONE ASSEMBLY
PHONE JACK W401	2113-1011-0	PHONE JACK 6312-03-070 W/CLIP
<u>ANTENNA ASSEMBLY</u> PC BOARD	MI-21490H-01-S	ANTENNA ASSEMBLY
*AH *B,B1,C	MI-21490H-02-S	ANTENNA ASSEMBLY
<u>LAMP ASSEMBLY</u> PC BOARD	MI-21490J-01-S	LAMP ASSEMBLY
LAMP LP901-LP902	2450-0716-0	LAMP 12V 90MA 5X10MM
<u>SPEAKER OUTPUT TERMINAL</u> PC BOARD	MI-21480E-01-S	SPEAKER ASSEMBLY
*AH *B,B1,C	MI-21480E-02-S	SPEAKER ASSEMBLY

Reference No	Part Number	Description
<u>MAINS ASSEMBLY</u>		
<u>PC BOARD</u>		
*AH	MI-21480D-01-S	MAINS ASSEMBLY
*B,B1,C	MI-21480D-02-S	MAINS ASSEMBLY
<u>DIODE</u>		
D001	4804-1480-C	DIODE 1N4148
<u>CAPACITORS</u>		
C001-C002 △	N89100049-0	CAP400V 4700P DE7150F472MVA1KC
<u>RESISTOR</u>		
*AH △	4705-275J-2	RCF 2.7M Ohm 1/4W 5% (DISCHARGE)
<u>TRANSISTOR</u>		
Q001	N4851815Y-5	TR 2SC1815-Y HFE 120-240
<u>RELAY</u>		
RLY1 △	N45000110-0	RELAY 12V DC TAIKO DGX1-12M
<u>SWITCH</u>		
SW1 △	5200-3481-0	POWER SW TV-3 3A/250V
<u>FRONT PANEL ASSEMBLY</u>		
<u>PC BOARD</u>		
	MI-21480B-01-S	FRONT PANEL ASSEMBLY
<u>CAPACITORS</u>		
C01	157F-105M-5-IU	CE 50V 1μF 20%
C04	153I-474J-9-NO	CM 63V 0.47μF 5%
<u>RESONATOR</u>		
CR01	N27030120-0	CERAMIC RESONATOR CSA 4.91MG
<u>DIODES</u>		
D001,D003	4804-1480-C	DIODE 1N4148
D04	N37003512-G	LED GREEN (L-424GDT)3MM
D05-D06	N37003513-Y	LED AMBER (L-424YDT)3MM
D07-D09	N37003512-G	LED GREEN (L-424GDT)3MM
D015-D017	4804-1480-C	DIODE 1N4148
<u>ICS</u>		
IC01	3130-4250-0	IC TMS77C82 OTP PROGRAMMED
IC02	N31303420-0	IC LC7582A SANYO LCD DRIVER
IC03	N31303600-0	MC14094BCP 8-BIT SIPO SR 3S
IC04	N31303450-0	IC X24C01P XICOR EEPROM
IC05	N89100033-0	IR RX KODENSHI HC-341F
<u>LCD DISPLAY</u>		
LCD01	N24601010-0	LCD DISPLAY
<u>TRANSISTORS</u>		
Q01	N4851815Y-5	TR 2SC1815-Y HFE 120-240
Q02-Q03	N48600660-5	TR 2SA1015GR

Reference No	Part Number	Description
SWITCHES		
SW1-SW4	N52003201-0-01	TACT LED GREEN SKWQFG ALPS
SW5	N52003231-0-01	TACT LED AMBER SKHQFH ALPS
SW6	N52003201-0-01	TACT LED GREEN SKWQFG ALPS
SW8-SW13	N52003241-0-01	TACT NO LED SKHQAC ALPS
TUNER & MAIN ASSEMBLY		
PC BOARD		
*AH	MI-21490A-01-S	TUNER & MAIN ASSEMBLY
*B,B1,C	MI-21490A-02-S	TUNER & MAIN ASSEMBLY
CAPACITORS		
C126	153F-473K-4-RY	CM 50V 0.047 μ F 10%
C132*AH	150F-470J-5-IF	CC 50V 47pF 5%
C132*B,B1,C	150F-390J-5-GG	CC 50V 39pF 5%
C209-C210	157D-106M-5-IU	CE 16V 10 μ F 20%
C216-C217	157D-106M-5-IU	CE 16V 10 μ F 20%
C227-C230	157D-106M-5-IU	CE 16V 10 μ F 20%
C233-C234	157D-106M-5-IU	CE 16V 10 μ F 20%
C237-C240	157D-106M-5-IU	CE 16V 10 μ F 20%
C243-C244	157D-106M-5-IU	CE 16V 10 μ F 20%
C280-C281	157D-106M-5-IU	CE 16V 10 μ F 20%
C301-C304	157D-106M-5-IU	CE 16V 10 μ F 20%
C305-C306	157D-476M-5-KW	CE 16V 47 μ F 20%
C307-C308	157D-107M-5-KW	CE 16V 100 μ F 20%
C309-C310	153F-823J-5-SY	CM 50V 0.082 μ F 5%
C311-C312	153I-474J-9-NO	CM 63V 0.47 μ F 5%
C313-C314	153F-183J-5-KP	CM 50V 0.018 μ F 5%
C315-C316	153F-104J-5-SY	CM 50V 0.1 μ F 5%
C401-C402	157D-106M-5-IU	CE 16V 10 μ F 20%
C405-C406	153F-152J-5-KW	CM 50V 1500pF 5%
C407-C408	153F-821J-5-HS	CM 50V 820pF 5%
C409-C410	157D-476M-5-KW	CE 16V 47 μ F 20%
C411-C412	153F-102J-5-IM	CM 50V 1000pF 5%
C415-C416	157C-228M-5-S9	CE 10V 2200 μ F 20%
C417-C418	153F-104J-5-SY	CM 50V 0.1 μ F 5%
C427-C428	157E-476M-5-IU	CE 25V 47 μ F 20%
C429-C432	153F-104J-5-SY	CM 50V 0.1 μ F 5%
C447-C448	15CH-300J-5-IG	CC 50V 30pF 5% NPO
C508-C509	N89100029-0	CE 50V 6800 μ F 20%
C516-C517	157I-477M-5-X&	CE 63V 470 μ F 20%
C518-C519	157F-227M-5-S5	CE 50V 220 μ F 20%
C522	157F-106M-5-IU	CE 50V 10 μ F 20%
C523	157F-476M-5-OW	CE 50V 47 μ F 20%
C526-C527	157F-227M-5-S5	CE 50V 220 μ F 20%
C540	157E-477Z-5-S5	CE 25V 470 μ F +80/-20%
C541-C543	157F-105M-5-IU	CE 50V 1 μ F 20%
C544-C545	157F-106M-5-IU	CE 50V 10 μ F 20%
C546	157D-106M-5-IU	CE 16V 10 μ F 20%
C701	1551-0210-0	TRIMCAP 5.2-30P TZ03R300FR MUR
C703	157B-107M-5-KM	CE 6.3V 100 μ F 20%
C704	157F-107M-5-OW	CE 50V 100 μ F 20%
C705	157F-335M-5-IU	CE 50V 3.3 μ F 20%
C707	157F-474M-5-IU	CE 50V 0.47 μ F 20%
C709	157Q-474M-5-IU	CE 35V 0.47 μ F 20%
C711	158F-101J-5-KW	CP 50V 100pF 5%
C712	157D-106M-5-IU	CE 16V 10 μ F 20%

Reference No	Part Number	Description
C721	1551-0210-0	TRIMCAP 5.2-30P TZ03R300FR MUR
C725	157D-106M-5-IU	CE 16V 10 μ F 20%
C726	157F-475M-5-IU	CE 50V 4.7 μ F 20%
C733	157F-335M-5-IU	CE 50V 3.3 μ F 20%
C738	157F-335M-5-IU	CE 50V 3.3 μ F 20%
C739	158F-101J-5-KW	CP 50V 100pF 5%
C741	157D-107M-5-KW	CE 16V 100 μ F 20%
C742	157F-104M-5-IU	CE 50V 0.1 μ F 20%
C743	157D-106M-5-IU	CE 16V 10 μ F 20%
C744	158F-391J-5-KW	CP 50V 390pF 5%
C745	157D-476M-5-IU	CE 16V 47 μ F 20%
C746	157D-107M-5-KW	CE 16V 100 μ F 20%
C747	157F-105M-5-IU	CE 50V 1 μ F 20%
C748	157F-224M-5-IU	CE 50V 0.22 μ F 20%
C749-C750	157F-105M-5-IU	CE 50V 1 μ F 20%
C751	157D-106M-5-IU	CE 16V 10 μ F 20%
C752-C753*AH	158F-911J-5-KW	CP 50V 910pF 5%
C752-C753*B,B1,C	158E-421J-5-KW	CP 25V 420pF 5%
C754-C755	153F-152J-5-KW	CM 50V 1500pF 5%
C756-C757	157D-476M-5-IU	CE 16V 47 μ F 20%
C801	157C-226M-5-IM	CE 10V 22 μ F 20%
C803-C804	157C-226M-5-IM	CE 10V 22 μ F 20%
C806	157C-226M-5-IM	CE 10V 22 μ F 20%
DIODES		
D202-D203	4804-1480-2	DIODE 1N4148
D403-D404	4804-1480-2	DIODE 1N4148
D411-D412	4804-1480-2	DIODE 1N4148
D505-D508	4805-4010-1	DIODE 1N5401
D511	N48400470-0	BRIDGE RECTIFIER RS102 100V 1A
D513	4837-24B4-2	ZD 0.5W 27V
D515,D517*AH	635N-0001-0	JUMPER #23 TAPE & WHEEL
D516*AH \triangle	471A-330J-1-X	RFP 33 Ohm 3W 5%
D518*AH \triangle	471A-470J-1-X	RFP 47 Ohm 3W 5%
D515-D518*B,B1,C	4840-1140-0	ZD 1.3W 3.3V 5%
D520	4840-0810-0	BRIDGE DIODE RB154 400V 1.5A
D521	4837-33V0-2	ZD 1/2W 33V (32.2-33.6)
D701-D702	N4801N60P-1	GERMANIUM DIODE IN60P
D703-D704	484C-321D-5	SVC321-D AM CAR. DIODE
D705-706	4804-1480-2	DIODE 1N4148
D801-D804	4804-1480-2	DIODE 1N4148
D805-D806	4837-8C20-2	ZD 1/2W 11.1-11.6V
ICS		
IC201	N31303710-0	IC TC 9163N HV ANALOG SW
IC202	N31303560-0	IC NJM072 (D)
IC203-IC204	3130-0890-0	IC NJM4558D DUAL OP AMP
IC301	N31303660-0	IC NJM2068D DUAL LN-OP AMP
IC501	3130-2020-3	IC L7805 5V REGULATOR
IC502	N31302520-1	IC L7812 12V REGULATOR
IC503	3130-3520-1	IC L7912CV -12V REGULATOR
IC701	N31303430-0	IC LM7000 SANYO DTS
IC702*AH	N89100034-0	TUNER MODULE MITSUMI FE407-A16
IC702*B,B1,C	1300-0606-0	FM TUNER MODULE FE407-G58
IC703	N31303390-0	IC LA1266 SANYO FM/AM TUNER
IC704	N31303400-0	IC LA3401 PLL MPX

<u>Reference No</u>	<u>Part Number</u>	<u>Description</u>
FILTERS & INDUCTORS		
FL1-FL3*AH	N27010546-1-0	CF SFE 10.7 ML-A
FL1-FL3*B,B1,C	N27010556-1-0	CF SFE 10.7 MZ2-A
FL703	N56002296-S	FTZ COIL SUMIDA
FL704-FL705	N56002236-S	19KHZ FILTER COIL
FL706	2701-0066-0	CF SFZ450G
L401-L402	1804-0540-0	SPRING COIL 1 μ H
L701, L703	1801-2R2M-M	INDUCTOR 2.2 μ H 20%
L702*B,B1,C	2701-0609-4	BPF BPEB1
L704	N56002276-S	AM RF COIL
L705	N56002286-S	AM OSC COIL
L706	N56002256-S	FM QUAD COIL PRIMARY
L707	N56002266-S	FM QUAD COIL SECONDARY
L708	N56002246-S	AM IF COIL
L710	N1801680M-M	INDUCTOR 68 μ H 20%
TRANSISTORS		
Q005-Q009	485C-930E-5	TR 2SC930E HFE 100-200
Q200, Q304	4860-0700-5	TR 2SC1815GR
Q201, Q303	N4851015Y-5	TR 2SA1015-Y HFE 100-200
Q202-Q203	N485363BL-5	TR N-FET 2SK-363
Q301-Q302	N48600770-5	TR 2SC2878 (A,B)
Q401-Q402	N485C550C-5	TR BC550C
Q403-Q406	N485C556B-5	TR BC556B
Q407-Q410	N485D1390-5	TR BD139-10 PHILIPS HFE63-160
Q411-Q412, Q507	N485669AC-5	TR 2SD669A-C
Q413-Q414, Q508	N485649AC-5	TR 2SB649A-C HFE 100-200
Q415-Q416	N48600730-5	TR 2SC3519 (O,P,Y)
Q417-Q418	N48600690-5	TR2SA1386 (O,P,Y)
Q509, Q701-Q703, Q710-Q713	4860-0700-5	TR 2SC1815GR
Q510	N4851015Y-5	TR 2SA1015-Y HFE 100-200
Q521	N485C546B-5	TR BC546B
Q704, Q714	N48600660-5	TR 2SA1015GR
RESISTORS		
R162*AH	4705-220J-2	RCF 22 Ohm 1/4W 5%
R162*B,B1,C \triangle	4715-100J-2-F	RFU 10 Ohm 1/4W 5%
R437-R438*AH	4705-680J-2	RCF 68 Ohm 1/4W 5%
R437-R438*B,B1,C \triangle	4715-470J-2-F	RFU 47 Ohm 1/4W 5%
R457-R458 \triangle	N4718100J-L-F	RFU 10 1W 5%
R463-R464 \triangle	N47183R3J-2-F	RFU 3.3 1W 5%
R465-R466*AH	635N-0001-0	JUMPER #23 TAPE & WHEEL
R465-R466*B,B1,C \triangle	4715-220J-2-F	RFU 22 Ohm 1/4W 5%
R467-R470 \triangle	N4719R22J-1	RCE 0.22 2W 5%
R511 \triangle	N4718100J-L-F	RFU 10 1W 5%
R512*AH \triangle	N4715101J-2-P	RFP 100 2W 5%
R512*B,B1,C \triangle	4718-101J-1-F	RFU 100 Ohm 1W 5%
R707*AH	4705-101J-2	RCF 100 Ohm 1/4W 5%
R707*B,B1,C \triangle	4715-470J-2-F	RFU 47 Ohm 1/4W 5%
R735*AH	4705-103J-2	RCF 10K Ohm 1/4W 5%
R735*B,B1,C	4705-432J-2	RCF 4.3K Ohm 1/4W 5%
R752*AH	4705-220J-2	RCF 22 Ohm 1/4W 5%
R752*B,B1,C \triangle	4715-100J-2-F	RFU 10 Ohm 1/4W 5%
R756-R757*AH	4705-823J-2	RCF 82K Ohm 1/4W 5%

<u>Reference No</u>	<u>Part Number</u>	<u>Description</u>
R756-R757*B,B1,C	4705-124J-2	RCF 120K Ohm 1/4W 5%
R901 △	4718-470J-1-X	RFP 47 Ohm 1W 5%
R920*AH	4705-750J-2	RCF 75 Ohm 1/4W 5%
R920*B,B1,C	4705-390J-2	RCF 39 Ohm 1/4W 5%
R925*AH	4705-331J-2	RCF 330 Ohm 1/4W 5%
R925*B,B1,C	4705-152J-2	RCF 1.5K Ohm 1/4W 5%
R928*AH	4705-220J-2	RCF 22 Ohm 1/4W 5%
R928*B,B1,C △	4715-100J-2-F	RFU 10 Ohm 1/4W 5%
R933*AH	4705-220J-2	RCF 22 Ohm 1/4W 5%
R933*B,B1,C △	4715-100J-2-F	RFU 10 Ohm 1/4W 5%
R935*AH	4705-331J-2	RCF 330 Ohm 1/4W 5%
R935*B,B1,C	4705-152J-2	RCF 1.5K Ohm 1/4W 5%
TRIMMER RESISTORS		
R411-R412	4756-2216-3-06	SVR 220 H3 7X7.6
R443-R444	4756-2216-3-06	SVR 220 H3 7X7.6
R736	N47562240-3-11	SVR 220K H3 10X10
RR742	N47561040-3-11	SVR 100K H3 10X10
R753	N47563330-3-11	SVR 33K H3 10X10
BREAKERS		
E401-E402 △	8910-0088-0	BREAKER 2.5A A-25
FUSES		
F503-F504*AH △	5120-0019-0	FUSE 4A 125V TIME LAG LBC UL/CSA
F505-F507*AH △	5120-0026-0	FUSE 315mA 250V TIME LAG LBC UL/CSA
F503-F504*B,B1,C △	5120-0017-0	FUSE 4A 250V TIME LAG HBC SEMKO/VDE
F505-F507*B,B1,C △	5120-0027-0	FUSE 315mA 250V TIME LAG LBC SEMKO/VDE
RESONATOR		
X102	2703-0020-0	CR RESONATOR CSB456F11
CRYSTAL		
X701	N23000440-0	CRYSTAL 7.2MHZ 20PPM

- NOTE :** - The components identified by △ mark are critical for risk of fire and electrical shock.
 Replace only with part number specified.
- <*AH > : USA, Canadian model only.
 - <*B > : UK model only.
 - <*B1 > : Australian model only.
 - <*C > : European model only.
 - Capacitors : CP-Polystyrere, CM-Mylar, CE-Electrolytic, CC-Ceramic.
 - Resistors : RMF-Metal Film, RFU-Fusible, RCF-Carbon Film, RCE-Ceramic Case, RFP-Flame Proof.

PACKING DIAGRAM

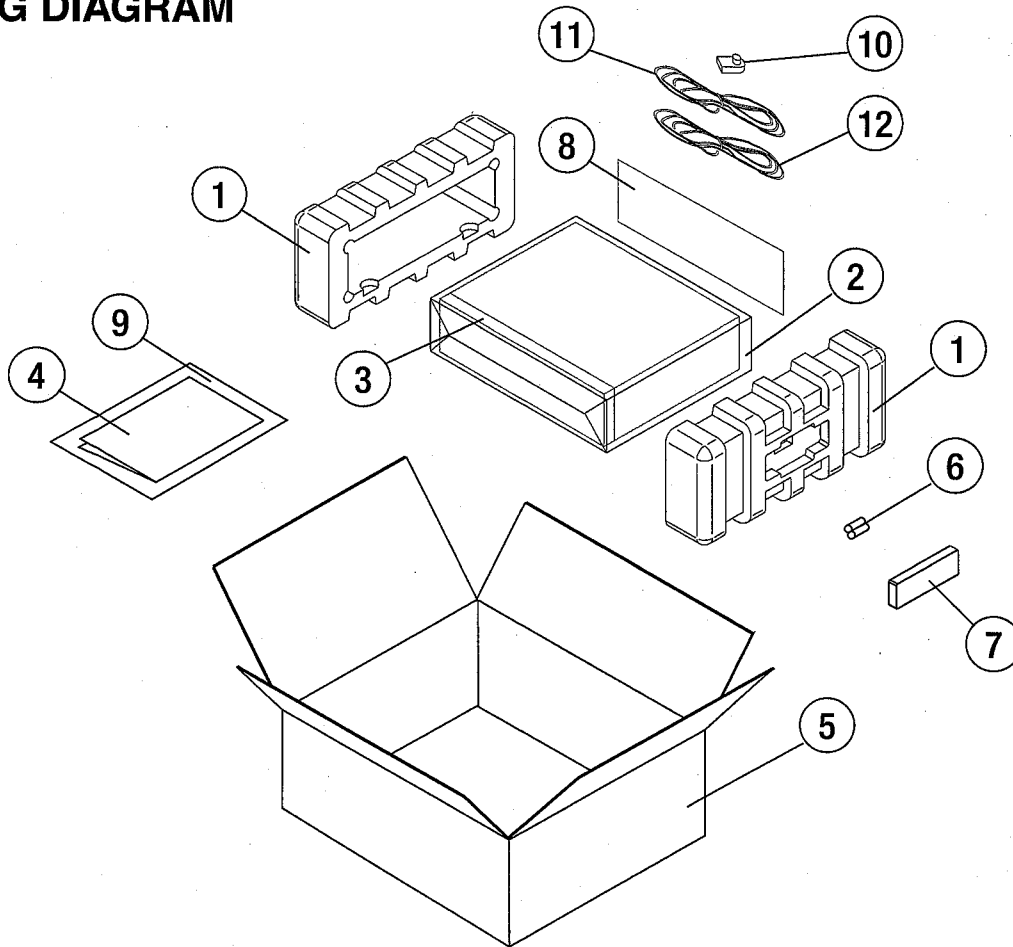

PACKING LIST

<u>Item</u>	<u>Part No</u>	<u>Description</u>	<u>Qty</u>
1	1490-1843-1	POLYFOAM END CAP	2
2	N14971332-1	UNIT POLYBAG	1
3	N14971442-0	FASCIA COVER	1
4	4301-3587-1	INSTRUCTION MANUAL	1
5	N14763601-0	CARTON BOX	1
6	4060-0580-0	BATTERIES	2
7	8900-1070-0	REMOTE CONTROL	1
8	1497-1302-0	ACCESSORIES POLYBAG	1
9	N14971062-0	MANUAL POLYBAG	1
10*AH	N21036101-0	RF CONNECTOR PLUG F-Type	1
10*B,B1,C	N21036201-0	RF CONNECTOR PLUG DIN-Type	1
11	N21070661-1	300-OHM T ANTENNA	1
12	N70093220-0	200CM WHITE AWG22	1

NOTE : <^AH > : USA, Canadian model only.
 <^B > : UK model only.
 <^B1 > : Australian model only.
 <^C > : European model only.

Proprietary information for servicing purposes only. The information herein may not be used commercially without the prior written agreement of NAD Electronics Ltd., London, England.