

SERVICE MANUAL

NAD

SERVICE SAFETY PRECAUTIONS (UL)

1. Use exact replacement parts for critical locations marked "⚠"
2. Return lead dress to original position and re-install protective covers.
3. Before returning to customer, test for shock hazard; use either method A or B:
 - A. Leakage test "cold":
 1. Unplug the AC cord; turn power switch ON.
 2. Connect one lead of High Voltage Insulation Tester to both prongs of the AC plug.
 3. Touch other lead to all exposed metal parts.
 4. Impedance measurement must be 0.3-5.0 Megohms.
 - B. Leakage test, "live" :
 1. Plug unit directly into the AC outlet; do not use isolation transformer.
 2. Connect one lead of the Leakage Current Tester to earth ground.
 3. Touch other lead to all exposed metal parts.
 4. Leakage measurement must be less than 0.5 milliamps.

512
COMPACT
DISC PLAYER

512
COMPACT
DISC PLAYER

SAFETY INFORMATION

CAUTION

CAUTION - INVISIBLE LASER RADIATION WHEN OPEN AND INTERLOCKS DEFEATED. AVOID EXPOSURE TO BEAM.

ADVARSEL - USYNLIG LASERSTRÅLING NÅR DEKSEL ÅPNES OG SIKKERHEDSLÅS BRYTES. UNNGÅ EKSPONERING FOR STRÅLEN.

ADVARSEL - USYNLIG LASERSTRÅLING VED ÅBNING, NÅR SIKKERHEDSAFBRYDERE ER UDE AF FUNKTION. UNDGÅ UDSÆTTELSE FOR STRÅLING.

VARING - OSYNLIG LASERSTRÅLNING NÅR DENNA DEL ÄR ÖPPNAD OCH SPÄRRAR ÄR URKOPPLADE. STRÅLEN ÄR FARLIG.

VARO! - AVATTAESSA JA SUOJALUKITUS OHITETTAESSA OLET ALTTINA NÄKTMÄTONTÄ LASERSÄTEILYLLE. ÄLÄ KAISO SÄTEESEEN.

VORSICHT! - UNSICHTBARE LASERTRÄHLUNG TRITTT AUS, WENN DECKEL GEÖFFNET UND WENN SICHERHEITVERRIEGELUNG ÜBERBRÜCKT IST. NICHT DEM STRAHL AUSSETZEN.

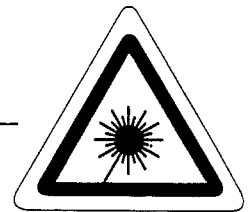
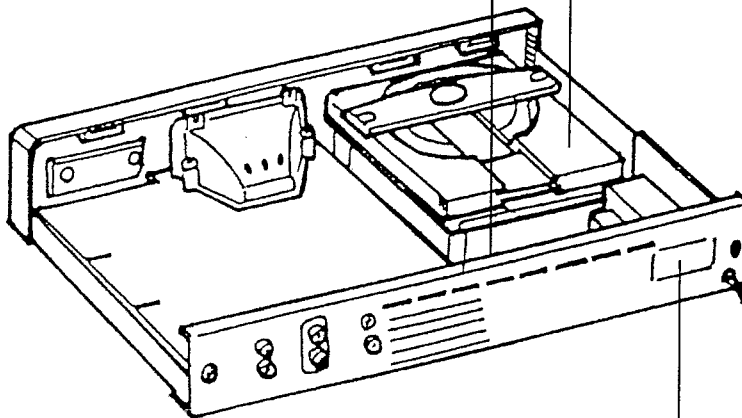

**CLASS I
LASER PRODUCT**



The lightning flash with arrowhead, within an equilateral triangle is intended to alert the user of the presence of uninsulated "dangerous voltage" within the product's enclosure; that may be of sufficient magnitude to constitute a risk of electric shock to persons.



The exclamation point within an equilateral triangle is intended to alert the user of the presence of important operating and maintenance (servicing) instructions in the literature accompanying the appliance.

THIS DEVICE COMPLIES WITH PART 15 OF THE FCC RULES.
OPERATION IS SUBJECT TO THE FOLLOWING TWO CONDITIONS :-
(1) THIS DEVICE MAY NOT CAUSE HARMFUL INTERFERENCE, AND
(2) THIS DEVICE MUST ACCEPT ANY INTERFERENCE RECIVED,
INCLUDING INTERFERENCE THAT MAY CAUSE UNDESIED
OPERATION.

CONTENTS

DESCRIPTION	PAGE
SPECIFICATIONS	4
REAR PANEL / FRONT PANEL VIEW	5
BLOCK DIAGRAM	6
WIRING DIAGRAM	7
DISASSEMBLY INSTRUCTIONS	8
ALIGNMENT PROCEDURE	9 -11
GUIDANCE ON FOCUS AND TRACKING GAIN ADJUSTMENT	12
IMPORTANT NOTES	13 -14
PCB LAYOUT (PARTS SIDE)	15 -16
SCHEMATIC DIAGRAM	17 -18
IC BLOCK DIAGRAM	19 -21
TROUBLESHOOTING GUIDE	22
EXPLODED VIEW	23
EXPLODED VIEW PARTS LIST	24
MECHANISM EXPLODED VIEW	25 -27
ELECTRICAL PARTS LIST	28 -30
PACKING DIAGRAM	31

SPECIFICATIONS

Disc Capacity	One Disc, 120 or 80 mm
Programming Capacity	21 Tracks
Decoding	MASH 1-bit converter
Digital Filter	4 Times oversample Linear phase with 18 bit coefficients
Analog Filter	5 pole active
Frequency Response	5 Hz - 20 kHz ± 0.5 dB
De-Emphasis Error	± 0.3 dB
THD (at 0 dB, 1 kHz)	0.0025%
Intermodulation Distortion	< -100 dB (19 + 20 kHz)
Dynamic Range	98 dB
Linearity	± 0.5 dB, 0 dB to -90 dB
Signal / Noise Ratio (A-Weighted)	105 dB, De-Emphasis on 108 dB, De-Emphasis off
Channel Separation 1 kHz	> 100 dB
10 kHz	> 90 dB
Wow and Flutter	Unmeasurable (Quartz Crystal Accuracy)
Output Impedance	120 Ω
Output level at 0 dB	2.2 V rms
Digital Error Correction	CIRC with double error correction in C1 and C2
Digital Code Output	Sony / Philips serial data format
Remote Control Unit	Yes

CONTROLS

Random, Play / Pause, Stop, Skip (< >), Scan (< >), Program, Time, Repeat.

PHYSICAL SPECIFICATIONS

Dimensions (Width x Height x Depth)	435 x 93 x 295 (mm)
Net weight	4.4 kg (9.7 lbs)
Shipping weight	5.6 kg (12.35 lbs)

REAR PANEL / FRONT PANEL VIEW

REAR PANEL

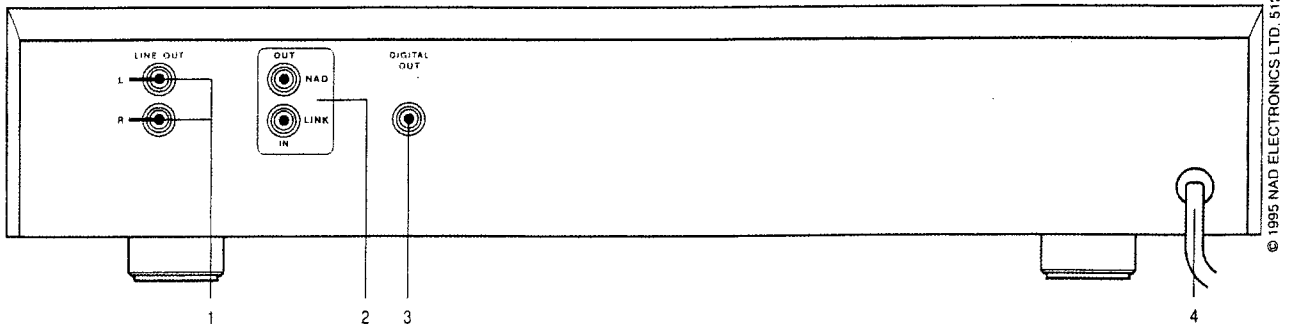

- 1. LINE OUTPUT
- 2. NAD LINK IN / OUT

- 3. DIGITAL OUTPUT
- 4. AC LINE CORD

FRONT PANEL

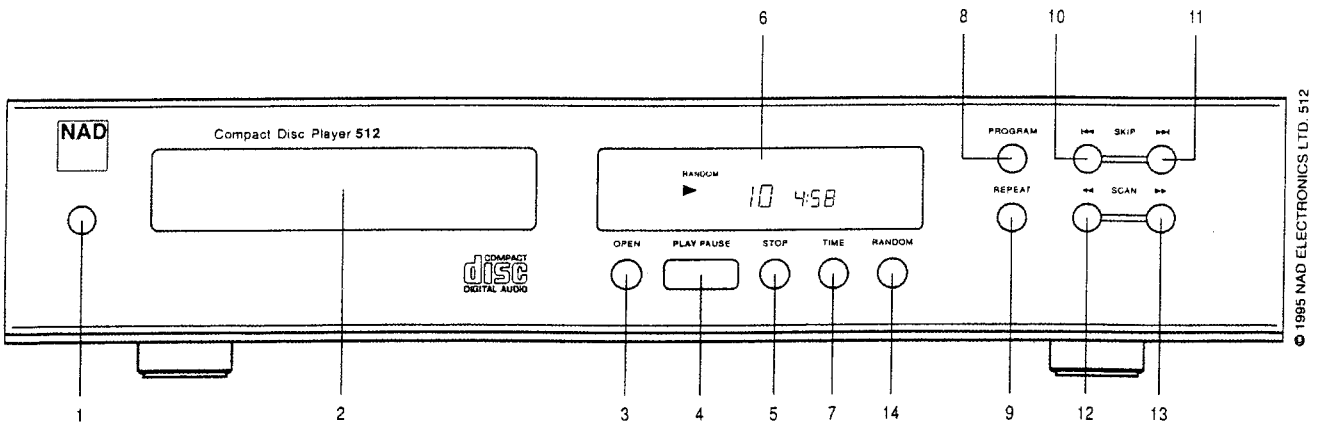

- 1. POWER ON / OFF
- 2. DISC DRAWER
- 3. OPEN
- 4. PLAY / PAUSE
- 5. STOP
- 6. DISPLAY
- 7. TIME

- 8. PROGRAM
- 9. REPEAT
- 10. SKIP Back (|◀◀)
- 11. SKIP Forward (▶▶|)
- 12. SCAN Back (◀◀)
- 13. SCAN Forward (▶▶)
- 14. RANDOM

BLOCK DIAGRAM

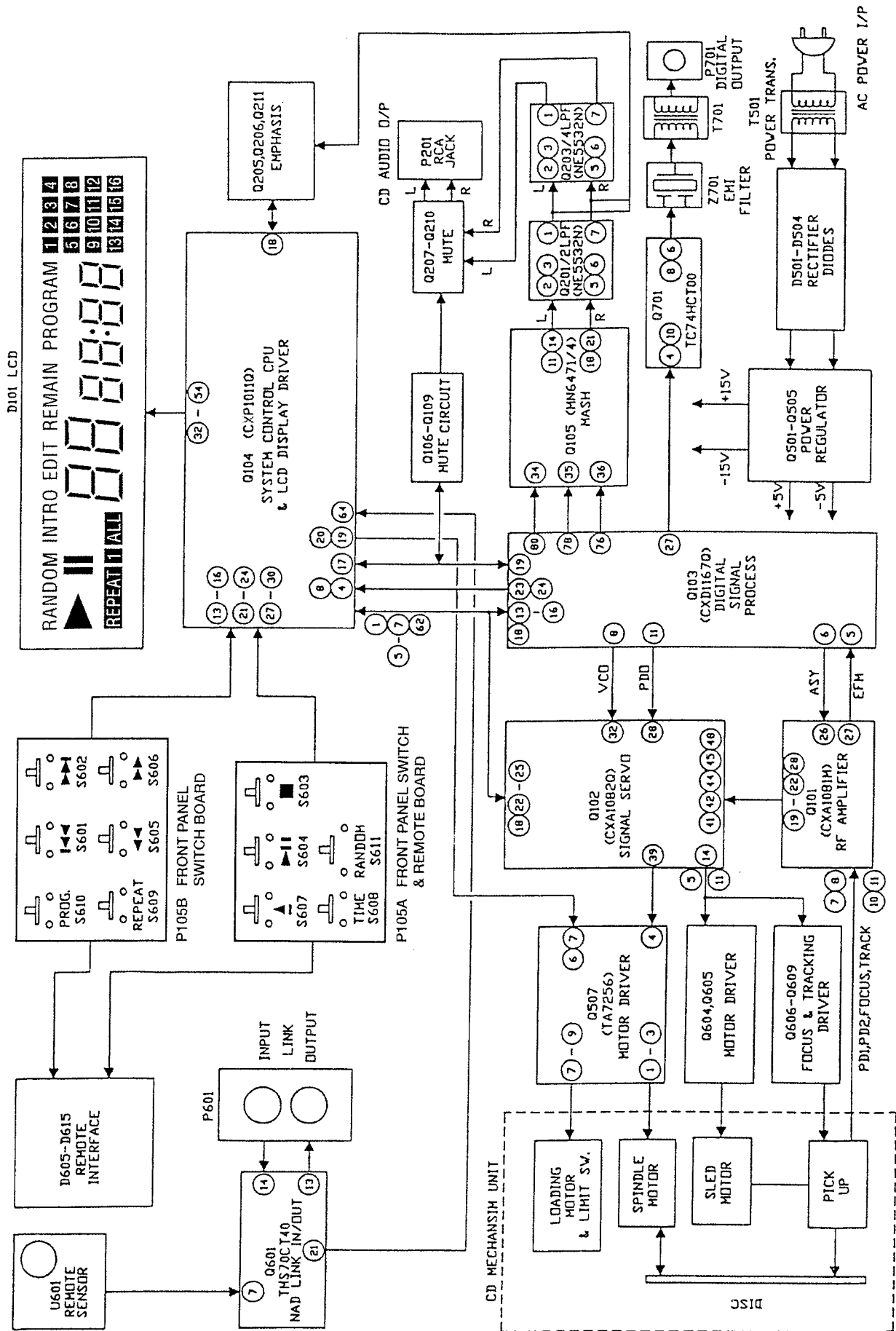

WIRING DIAGRAM

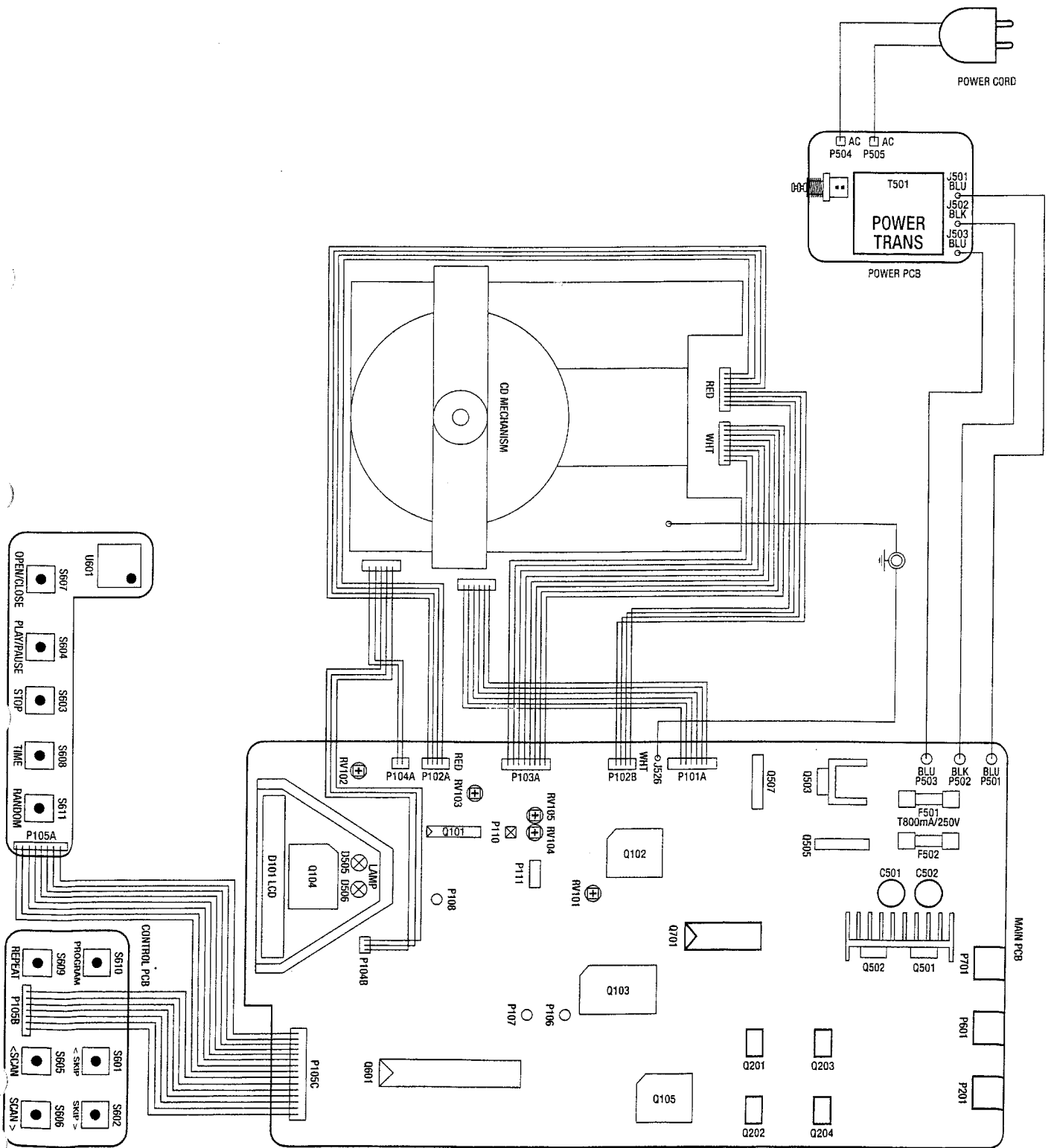

DISASSEMBLY INSTRUCTIONS

TOP COVER REMOVAL

1. Remove machine screws M 4.0 x 6.0 (① to ④) from the side panels.
Remove tapping screw 3.0 x 8.0 (⑤) from the back panel.
Refer to figure No. 1.

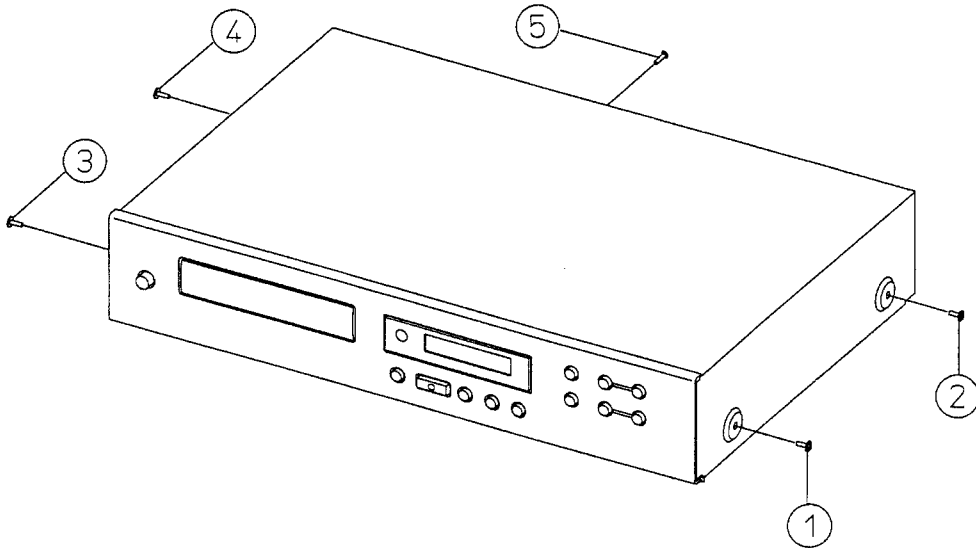

Figure No. 1.

2. Pull both sides of the TOP COVER slightly outwards and tilt approx. 35° and then remove in the direction as indicated by pointer ⑦ in figure No. 2.

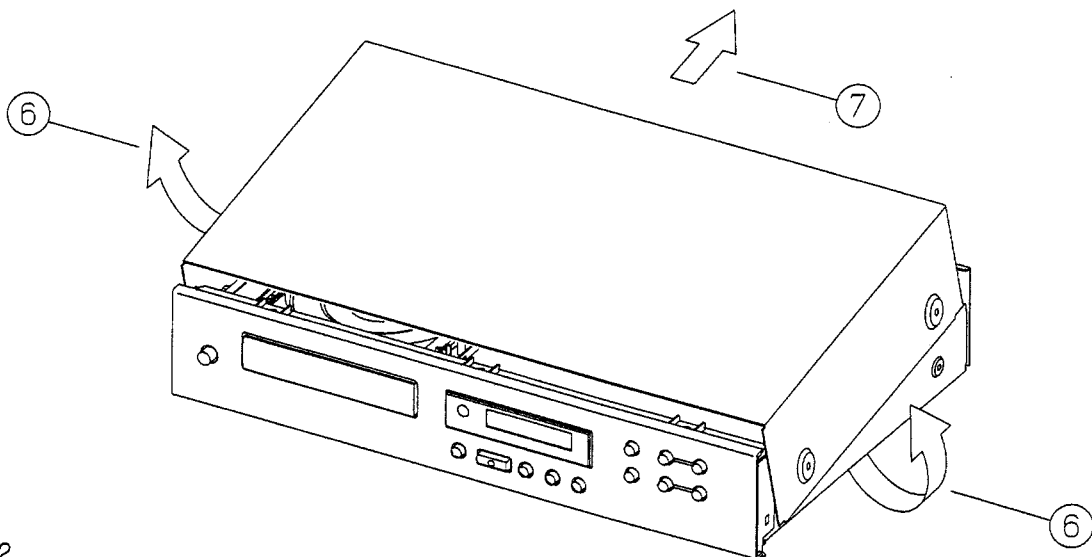
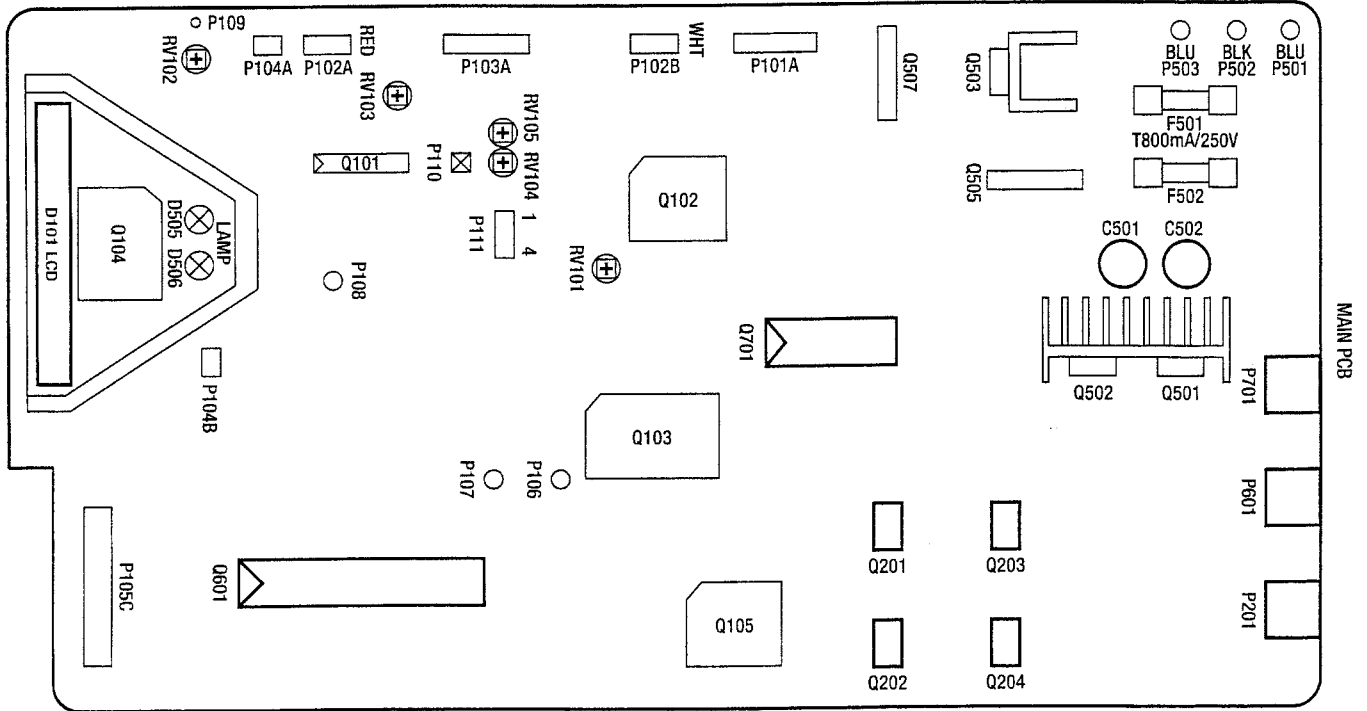

Figure No. 2.

ADJUSTMENT POINTS DIAGRAM



NAD - 512 PCB ADJUSTMENT POINTS DIAGRAM

ALIGNMENT PROCEDURE

REQUIRED INSTRUMENTS:

SPECIAL JIG (SEE FIG. 1), OSCILLOSCOPE (BANDWIDTH GREATER THAN 40 MHz)
 FREQUENCY COUNTER AND TEST DISC (SONY YEDS-7).

Step A: PLL Adjustment

- (1) Turn power ON and press the STOP key.
- (2) Short circuit P108 (ASSY) to P107 (GND).
- (3) Connect the frequency counter to P106 (CLK) and P107 (GND).
- (4) Adjust RV101 for a reading of 4.2318 +/- 0.01 MHz.
- (5) After this adjustment is completed remove the short circuit between P108 and P107.

Step B: RF Adjustment

- (1) Load the test disc and set the unit into PLAY mode.
- (2) Connect the scope to P109 (RF) and P107 (GND).
Scope setting: Coupling : AC.
 Vertical sensitivity : 0.2 V/div.
 Horizontal time base : 0.5 μ S/div.
- (3) Adjust RV102 so that the 3T component of the waveform is maximum and the eye pattern is at its best shape (see Fig. 2).

Step C: EF Balance adjustment

- (1) Turn the power OFF, remove P111 and replace it with the special jig shown in Fig. 1.
- (2) Connect the scope as shown in Fig. 1 and switch the jig to the "ON" position.
Scope setting: Coupling : DC.
 Vertical sensitivity : 0.5 V/div.
 Horizontal time base : 2 mS/div.
- (3) Load the test disc and put the unit into PLAY mode.
- (4) Adjust RV103 so that the tracking error waveform is symmetrical (see Fig. 3).

NOTE: BEFORE CONTINUING REFER TO PAGE 12 FOR GUIDANCE ON FOCUS AND TRACKING GAIN ADJUSTMENT.

Step D: Focus gain adjustment

- (1) Put the unit into play mode.
- (2) Switch the special jig to "OFF" and leave the scope connected.
- (3) Connect Scope setting: Coupling : DC.
 Vertical sensitivity : 0.1 V/div.
 Horizontal time base : 2 mS/div.
- (4) Adjust RV105 so that the DC level is between 120 and 200 mV.
- (5) Turn the power OFF, remove the jig and return the original socket to P111.

Step E: Tracking gain adjustment

- (1) Turn the power ON, load the test disc and press PLAY.
- (2) Connect the scope to pin 3 of P111.
Scope setting: Coupling : DC.
 Vertical sensitivity : 0.2 V/div.
 Horizontal time base : 2 mS/div.
- (3) Adjust RV104 so that the waveform is as shown in Fig. 4(a).

FIG. 1

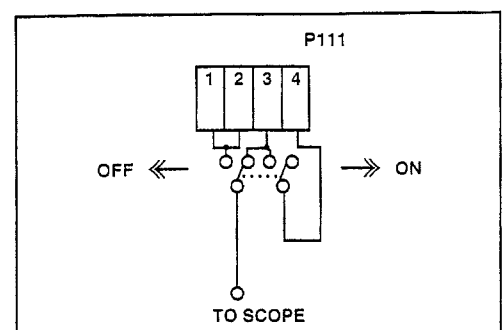

FIG. 2 (a)

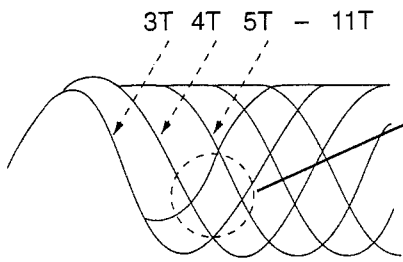

FIG. 2 (b) Poor eye pattern

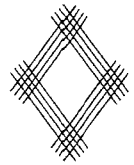

FIG. 2 (c) Good eye pattern

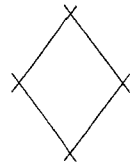

FIG. 3

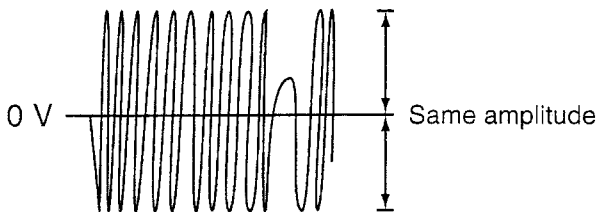

FIG. 4 (a) Good waveform

Volt/div : 0.2 V
Time/div : 2 mS



FIG. 4 (b) High tracking gain

(higher frequency than for low gain)

Volt/div : 0.2 V
Time/div : 2 mS

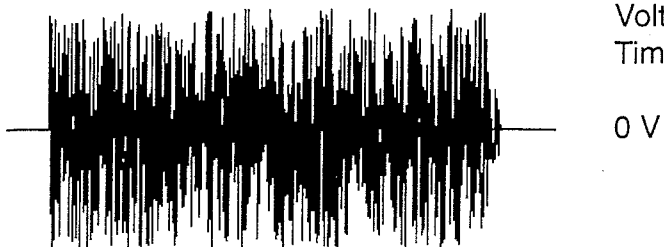
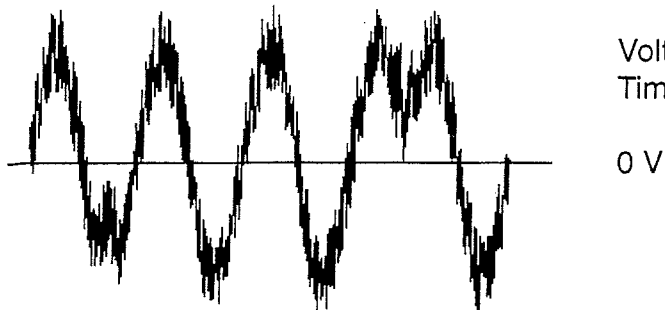

FIG. 4 (c) Low tracking gain

Volt/div : 0.2 V
Time/div : 2 mS



GUIDANCE ON FOCUS AND TRACKING GAIN ADJUSTMENT

NOTE: It is recommended that this adjustment is not carried out unless absolutely necessary.

A frequency response analyzer is necessary to carry out this adjustment precisely. However this adjustment has a wide tolerance so that even if the adjustment has not been performed exactly the player will still work with an acceptable level of performance.

The focus and tracking gain determine not only the vertical and horizontal tracking characteristics, but also the amount of mechanical noise from the optical blocks two axis device and its sensitivity to mechanical shock.

Correct adjustment will be at the point where all the above criteria are satisfied.

* When the gain is too high, the mechanical noise is high.

* When the gain is too low, the susceptibility to mechanical shock and skipping will be poor.

SYMPTOM	GAIN	
	focus	tracking
Time taken from stop to play is excessive, or track skip time is excessive. (normally approx. 2 sec)	low or high	low or high
Music does not start when play is pressed or track selection is made but disc rotates.		low
Drawer opens shortly after pressing PLAY.	low or high	
Intermittent sound during play or counter stops.		low
High mechanical noise from optical block during play.	high	high

IMPORTANT NOTES

INSTRUCTION FOR HANDLING OPTICAL SYSTEM BLOCK PICK-UP

Electrostatic breakdown of the laser diode in the optical system block may occur due to a potential difference caused by electrostatic charge accumulated on clothing, human body, etc. A ground must be provided as follows to prevent any electrostatic charge during unpacking or repair work.

1. Ground for Human Body

Be sure to wear a ground band (1M ohm) that is properly grounded to remove any static electricity that may be charged on the body.

2. Ground for Work Bench

Be sure to place a conductive sheet (1M ohm) or copper plate with proper grounding on the work bench or other surface on which the pick-up is to be placed.

3. Because the static electricity charge on the clothing does not discharge through the body grounding band, do not let clothing to get in contact with the pick-up unit.

INCORRECT

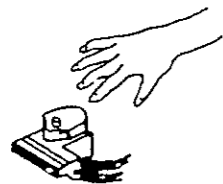

CORRECT

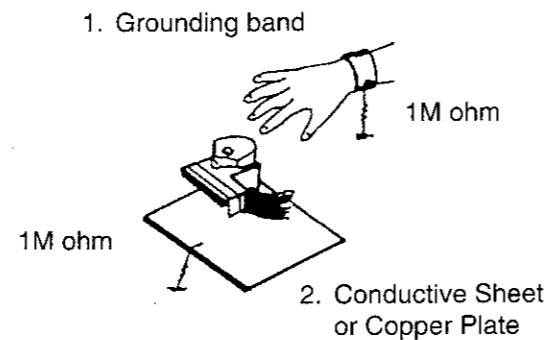

NOTE: Laser diodes are so susceptible to damage from static electricity that even if a static discharge does not ruin the diode, it can shorten its life or cause it to work improperly.

PRECAUTIONS FOR CHECKING BEAM EMISSION

The laser beam of this unit is focused on the reflecting surface of the objective lens in the optical system block. Therefore, keep your eyes at least 12 inches (30 cm) away from the objective lens when the laser diode is **ON**.

(Operation Check Method for Laser Diode and Focus Search Function.)

When the **POWER** switch is turned **ON** after the chucking plate is removed, observe the objective lens and confirm that the following operations are performed properly.

(The optical system block should be at the lead-in area position when it is checked at this time.)

- (1) The laser should be at the innermost position after the checking place is removed.
- (2) The diffused light of the laser beam can be seen when the **POWER** switch is turned **ON**.
- (3) Vertical (up and down) movement of the objective lens (2 or 3 times) will take place.

PRECAUTIONS WHEN CHANGING LASER PICK-UP

When removing the pick-up assembly, short circuit the PCB tracks on the optical block as shown in the drawing in order to protect the pick-up before removal.

NOTE: Replacement pickup assemblies are supplied with the PCB pattern already protected.

DO NOT REMOVE THE SHORT CIRCUITS UNTIL YOU HAVE FINISHED FITTING THE PICK-UP.

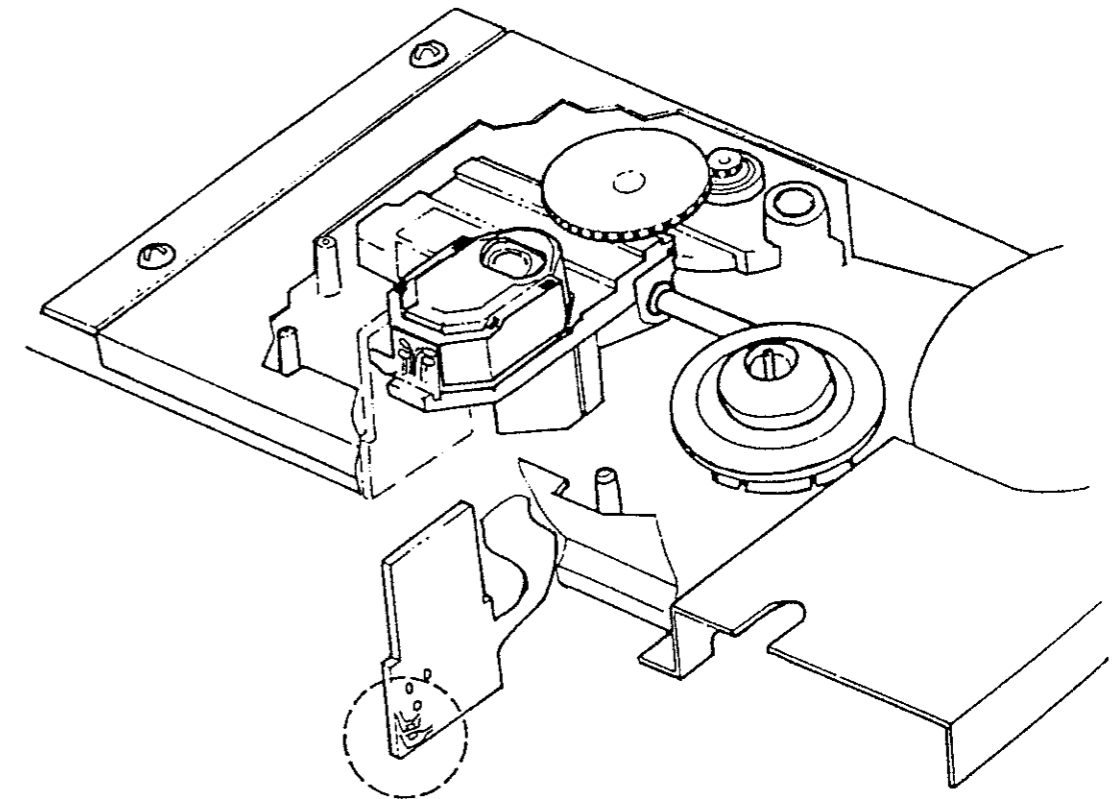

Caution:

Laser diodes are extremely susceptible to damage from static electricity. Even if a static discharge does not ruin the diode, it can shorten its life or cause it to work improperly. When replacing the pick-up, use a conductive mat, a grounded soldering iron, and so on, to protect the laser diode from static damage.

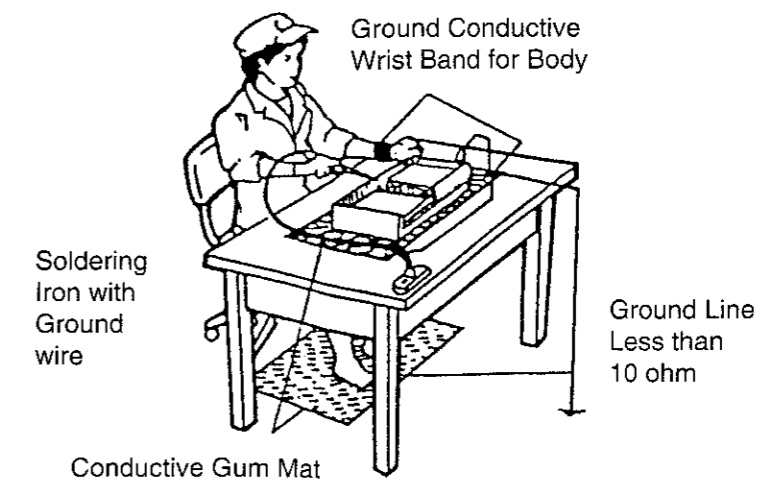

PCB LAYOUT (PARTS SIDE)

0000-9081-1217

CAUTION: FOR CONTINUED PROTECTION
AGAINST RISK OF FIRE,
REPLACE ONLY WITH SAME
TYPE FUSE.

ATTENTION: UTILISER UN
FUSIBLE DE RECHANGE
DU MEME TYPE

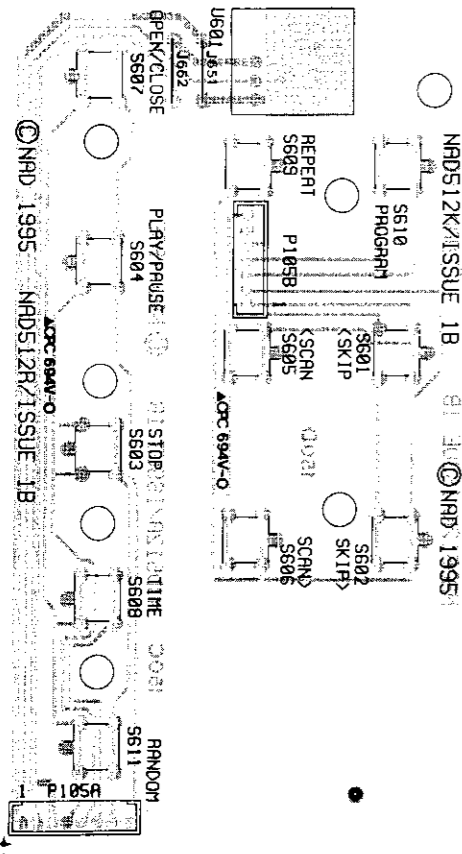
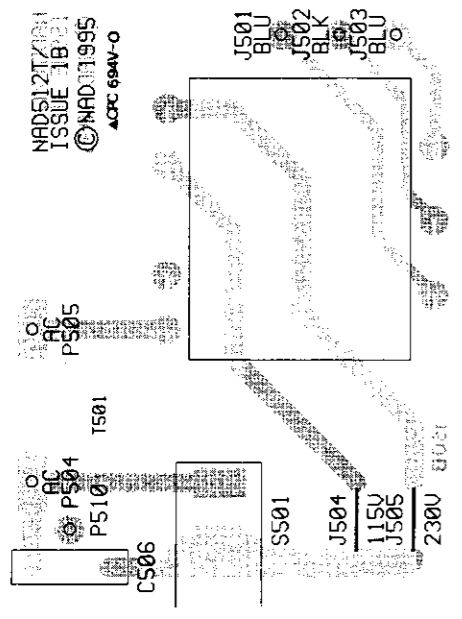
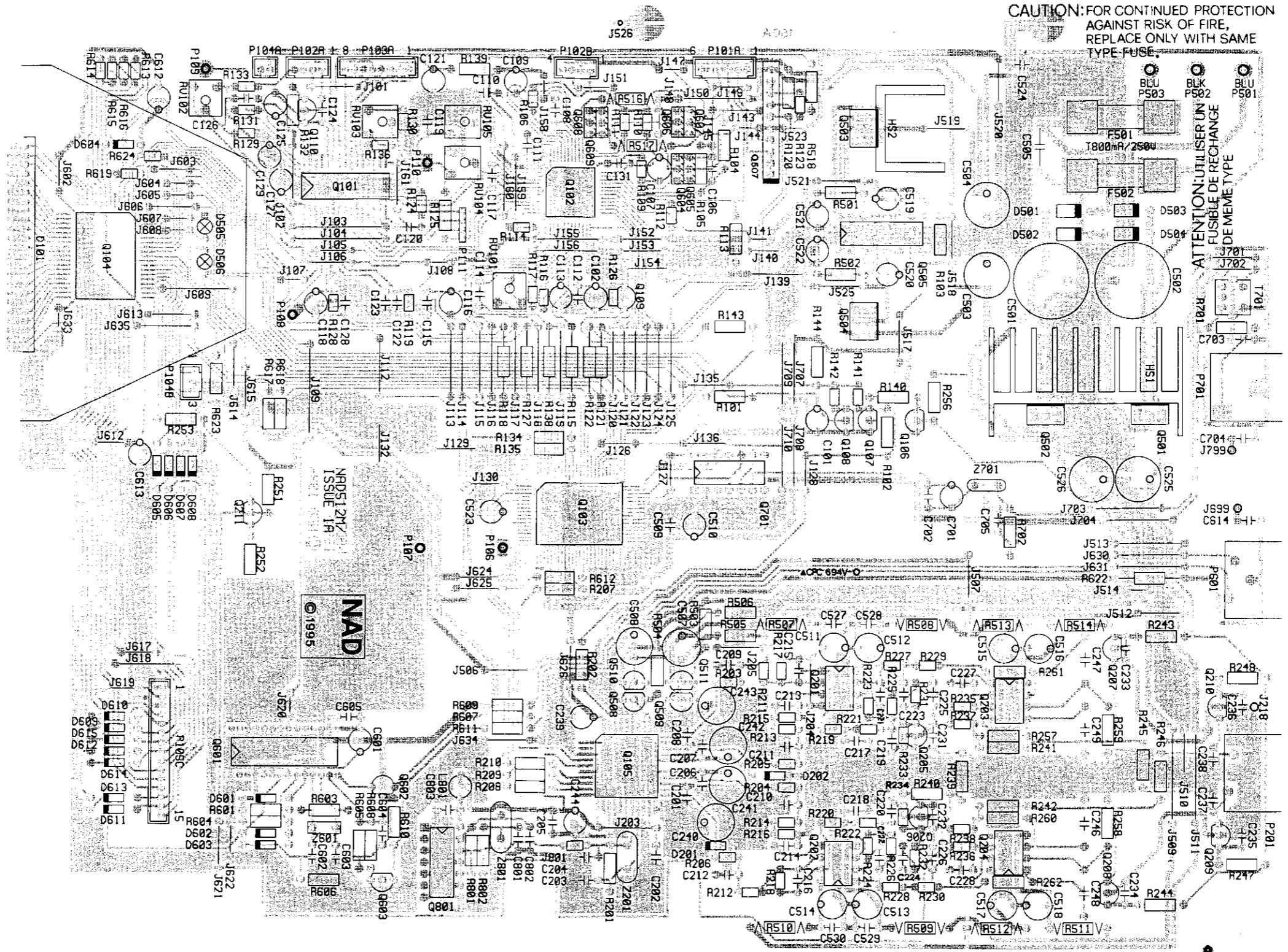

SCHEMATIC DIAGRAM

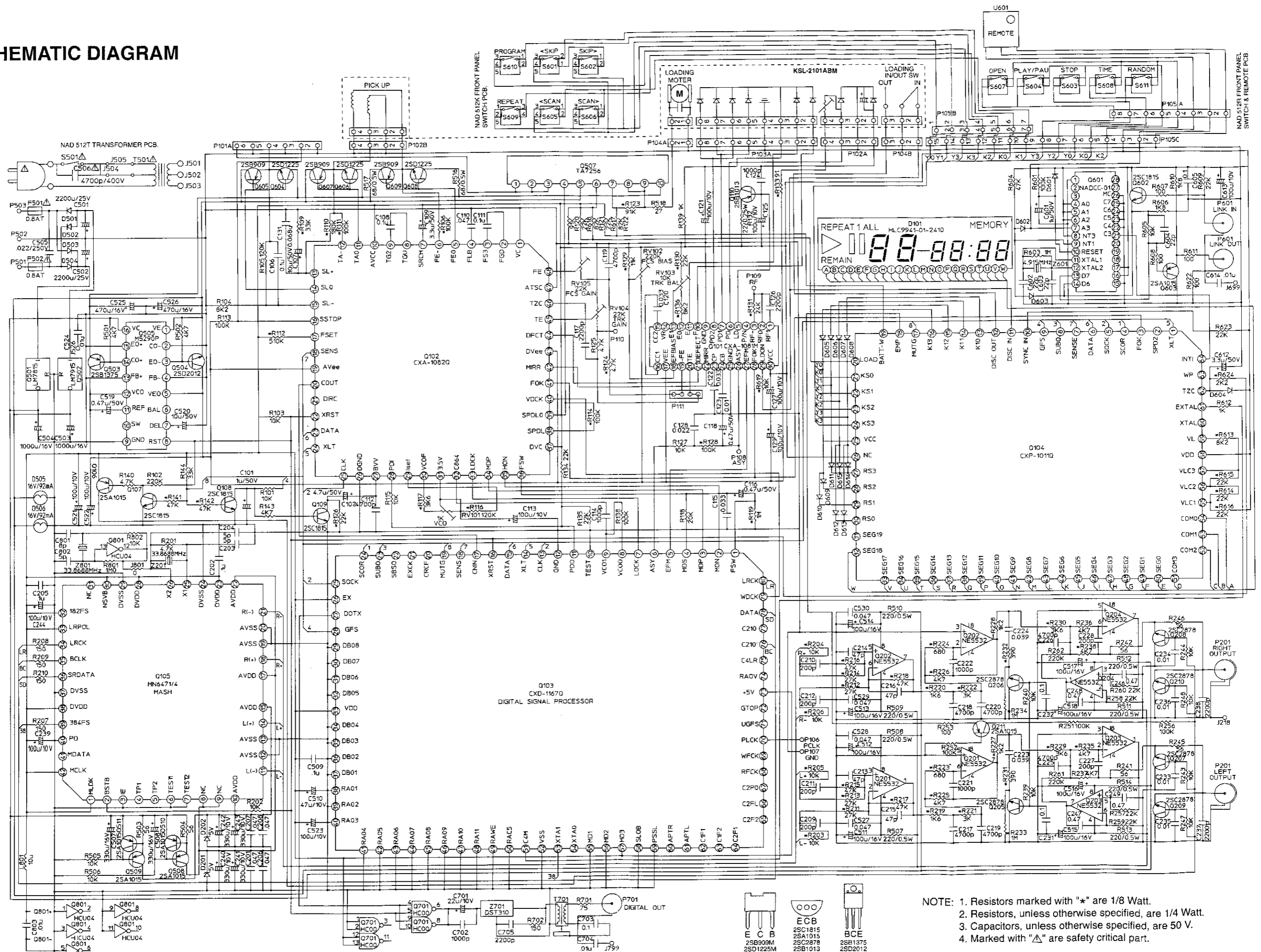

NOTE: 1. Resistors marked with "*" are 1/8 Watt.
 2. Resistors, unless otherwise specified, are 1/4 Watt.
 3. Capacitors, unless otherwise specified, are 50 V.
 4. Marked with "Δ" are safety critical part.

IC BLOCK DIAGRAM

Q101: CXA1081M

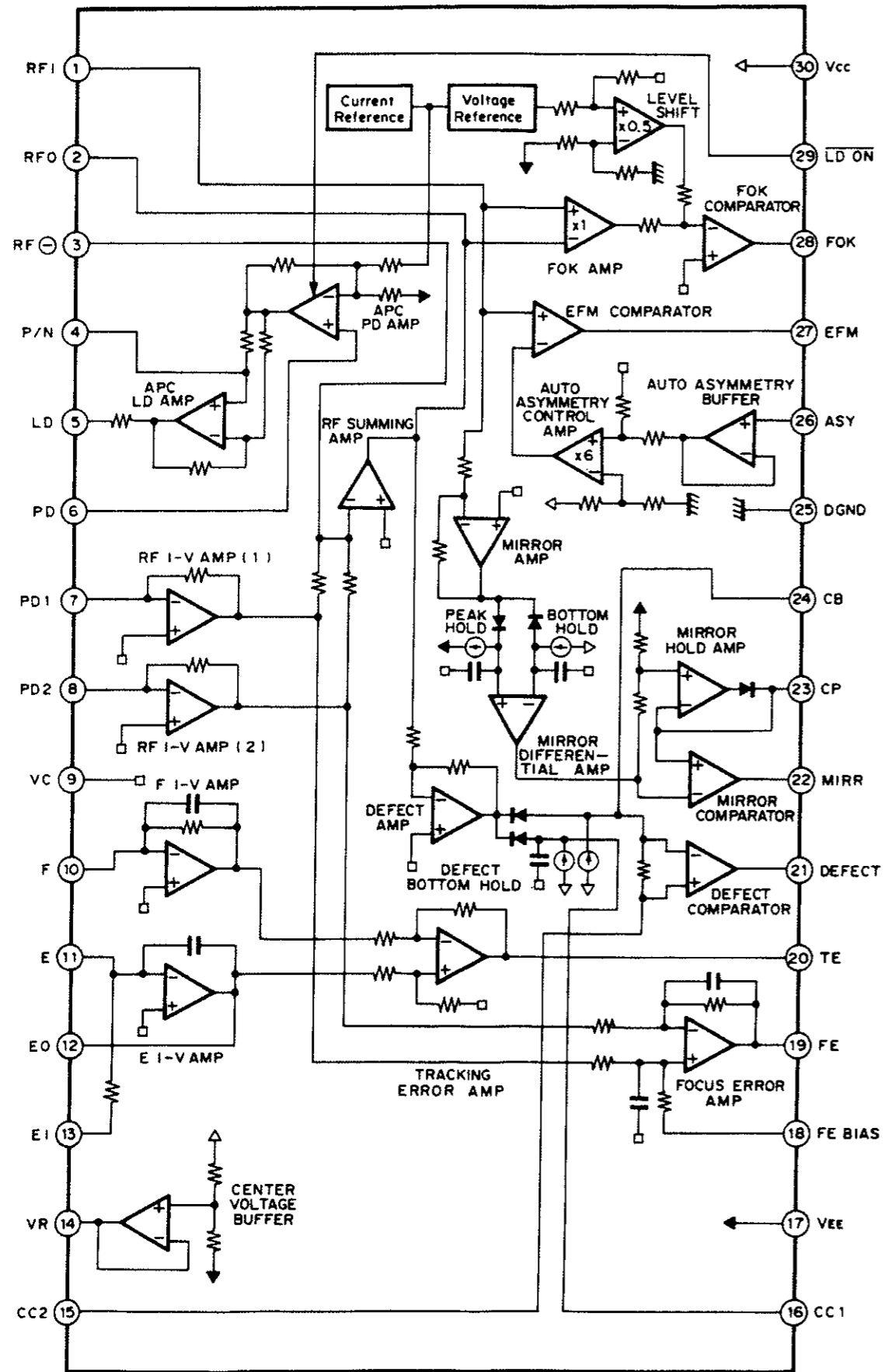

Q103: CXD1167Q

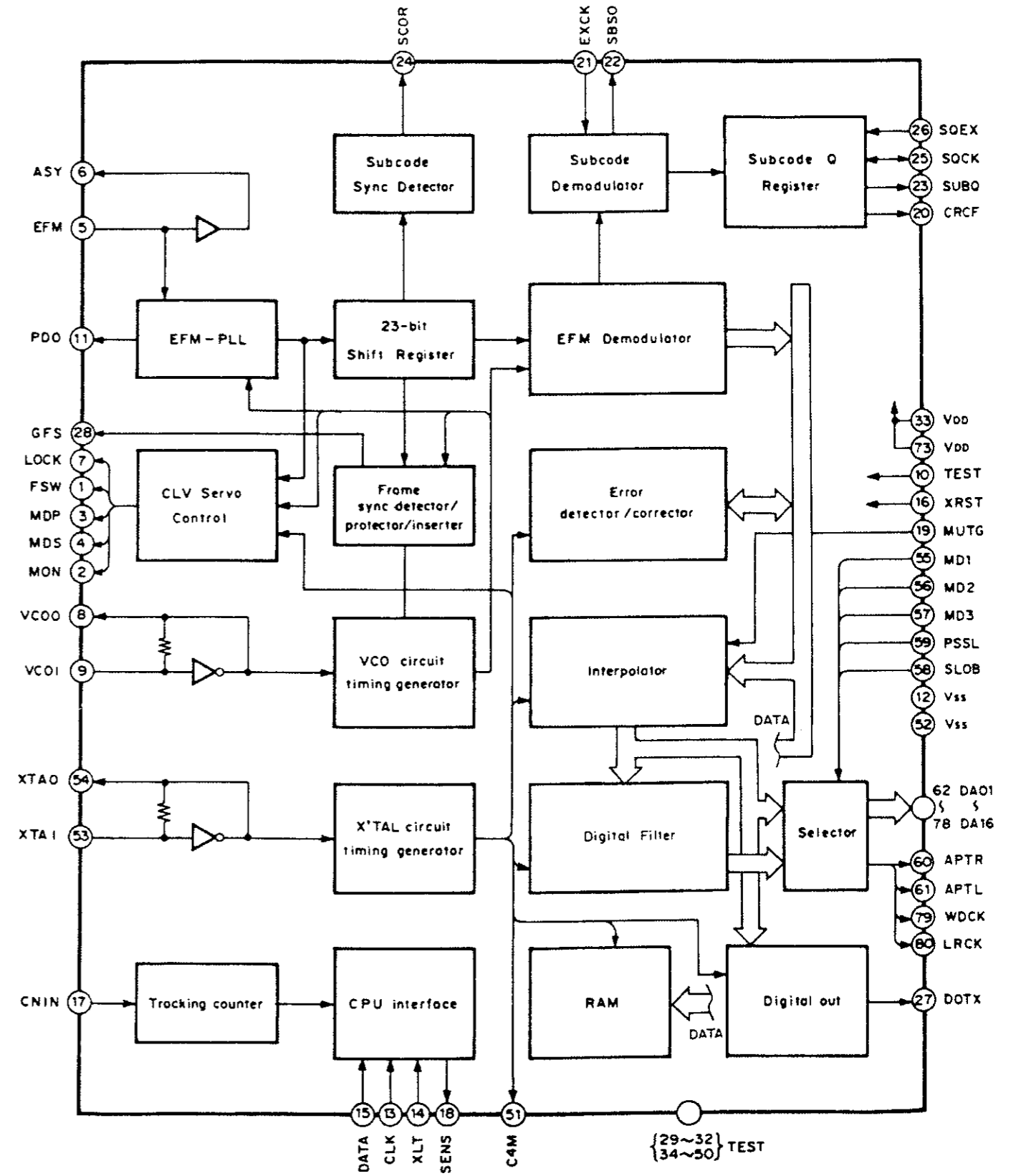

Q102: CXA1082BQ

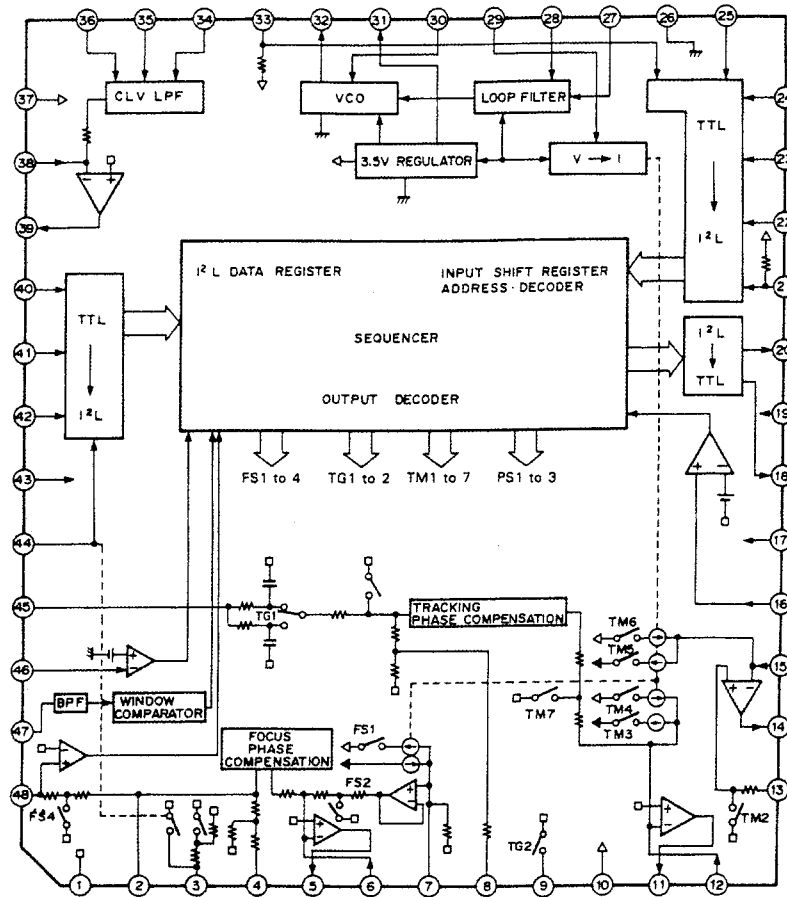

Q105: MN6471M / MN6474M

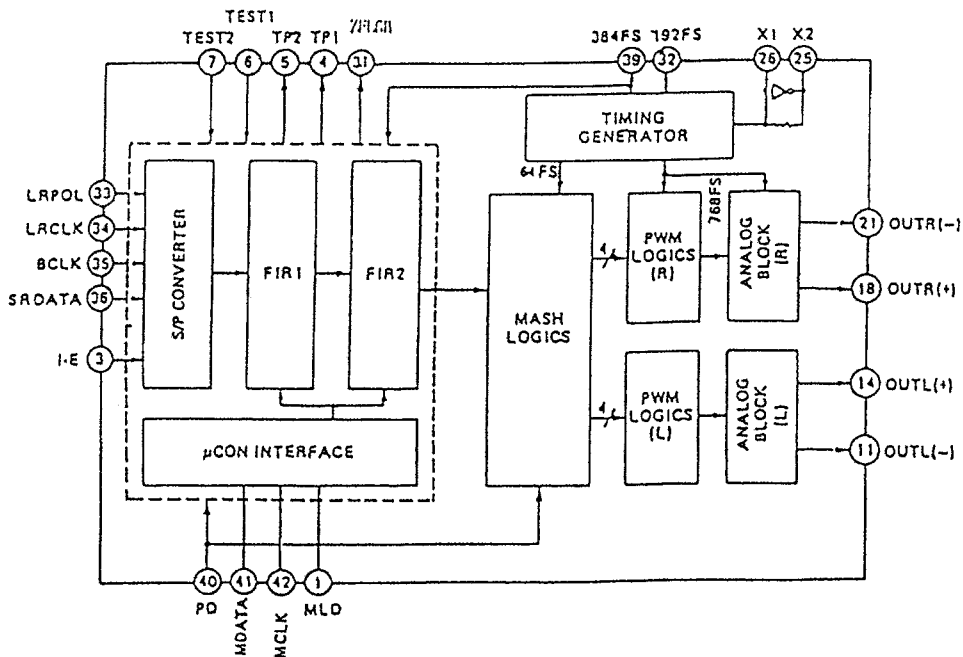

TROUBLESHOOTING GUIDE

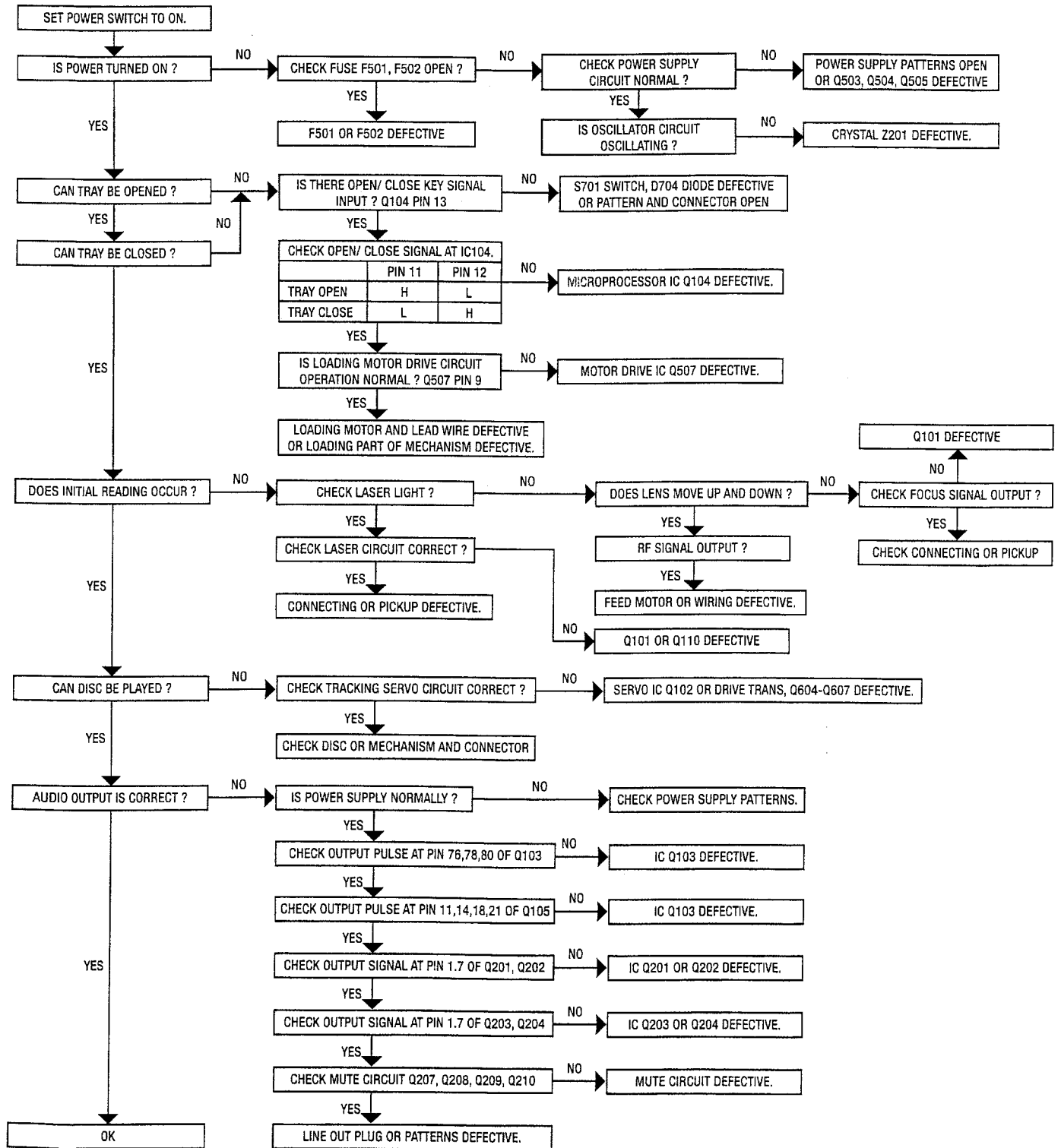

EXPLODED VIEW

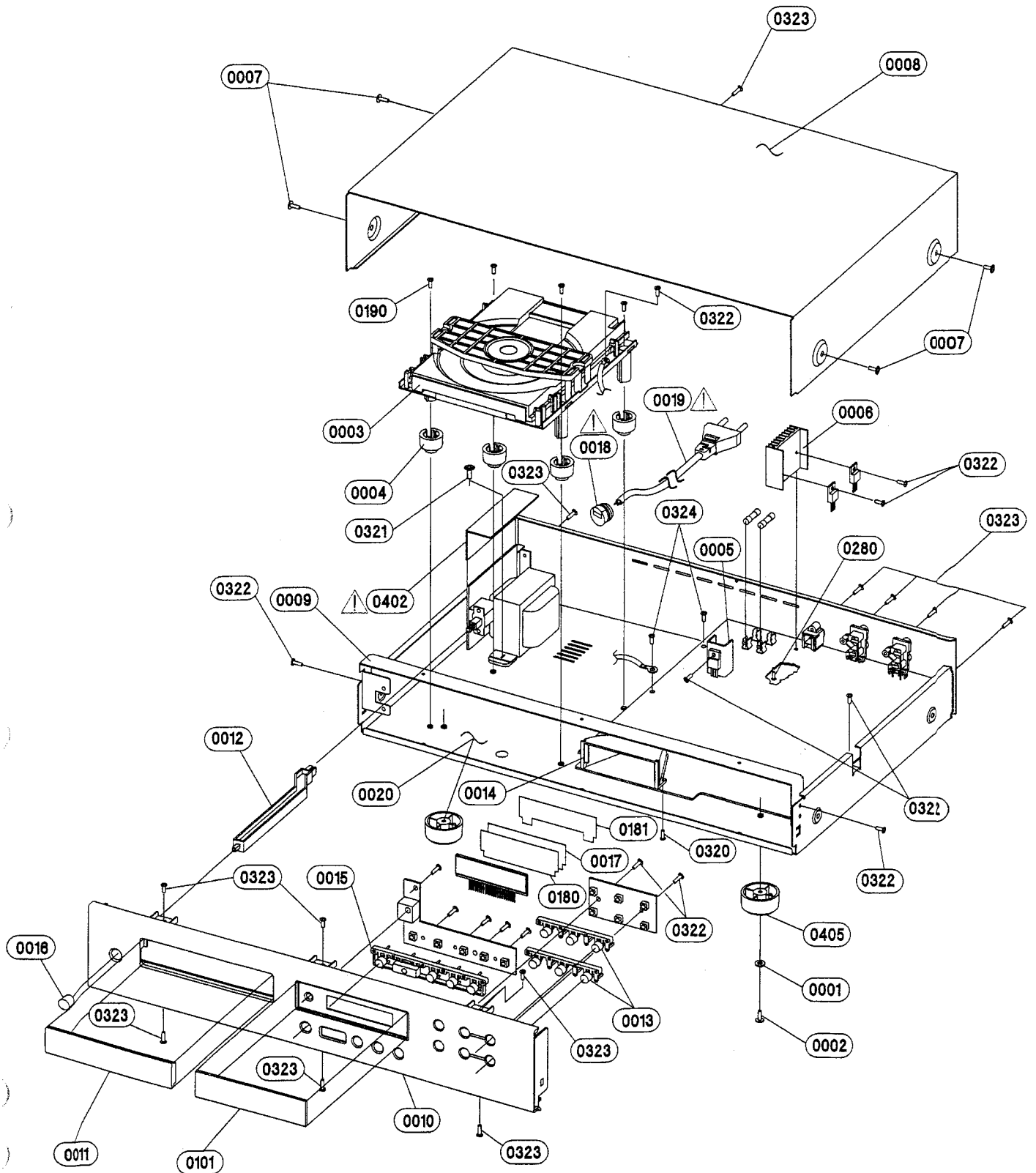

EXPLODED VIEW PARTS LIST

ITEM	PART NO.	DESCRIPTION	QTY
0001	2842-3367-0	METAL WASHER ID=3.3 OD=6.7	4
0002	2904-3008-0000	M3 X 8 MM BINDING HEAD (YEL.ZN)	4
0003	4111-0401-0	CD SONY KSL-2101ABM	1
0004	4152-0801-0	RUBBER CUSHION	4
0005	5400-0981-0	HEAT SINK SMALL	1
0006	5400-0991-0	HEAT SINK LARGE	1
0007	2900-4006-3010	M4 X 0.5P X 6 MM W/FLAT WASHER	4
0008	N14023770-0	TOP COVER	1
0009	N14023780-0	STRAP	1
0010	N14629411-0	FASCIA (512) W/SS	1
0011	N14629511-0	DOOR CD (512)	1
0012	N14629601-0	BUTTON EXTENSION	1
0013	N14629701-0	BUTTON SET	2
0014	N1462980B-0	LIGHT BOX LCD	1
0015	N14629901-0	MAIN BUTTON SET	1
0016	N2437510B-0	DIA 9.5 GLOSS POWER BUTTON ABS GN	1
0017	N3714590B-0	LIGHT BOX FILTER (LF NO.217)	1
0018	△ N41519461-0	STRAIN RELIEF BUSHING	1
0019*AH	△ N70093100-1	AC CORD 18AWG x 2 SPT-2UL/CSA	1
0019*C	△ N70093110-1	AC CORD (SEMKO)	1
0019*B	△ N70095110-1	AC CORD ASTA BS1363 W/3A FUSE	1
0019*B1	△ N70091190-0	AC CORD SAA AS3112 (AUS/NZ)	1
0020*AH	N14023761-0	CHASSIS W/SS	1
0020*B,B1,C	1402-3763-0	CHASSIS W/ " CE " MARKING	1
0101	N37146011-0	DISPLAY WINDOW W/SS	1
0180	3714-650B-0	LIGHT BOX FILTER (LF NO.202)	3
0181	3714-6606-0	LIGHT BOX FILTER (CLEAR)	1
0190	4132-2671-0	STUD M3	4
0280	2964-2308-0000	SCREW 2.3 X 8 B/H TAPPING YEL ZN	2
0320	2950-2005-0000	SCREW-ST PH 2 X 5	2
0321	2900-4006-3010	M4 X 0.5P X 6 MM W/FLAT WASHER	2
0322	2954-3008-0000	TAPPING 3 X 8 MM B-TITE (YEL.ZN)	14
0323	2954-3008-3000	TAPPING 3 X 8 MM B-TITE (BLK.ZN)	12
0324	2904-3008-0000	M3 X 8 MM BINDING HEAD (YEL.ZN)	2
0402	△ 4152-1001-0	PSU-PCB COVER PLATE	1
0405	N4151937-1	RUBBER FOOT	4

MECHANISM EXPLODED VIEW

KSL-2101ABM

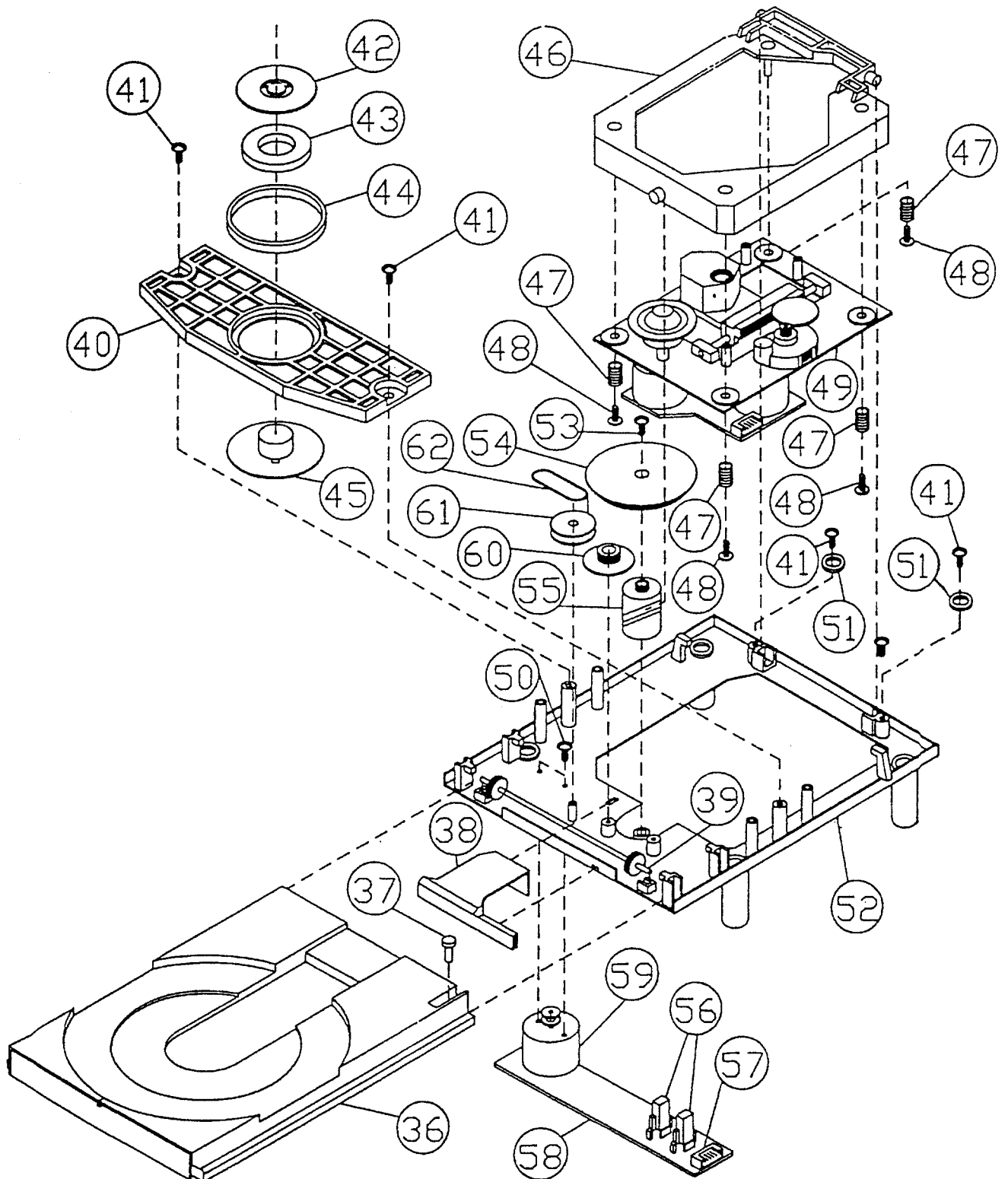

KSL-2101ABM SERVICE PARTS LIST

NO	PART NO	DESCRIPTION	Q'TY
36	2-626-009-(01)	TRAY (G)	1
37	THIS PART DOESN'T BELONG TO THE TRAY TAKE IT DOWN FROM OLD TRAY AND USE AGAIN WHEN CHANGING THE TRAY		
38	2-626-006-(01)	COVER (G), GEAR	1
39	2-625-998-(01)	GEAR (G), TRAY	1
40	2-626-004-(01)	PLATE (G) CHUCKING	1
41	2-319-501-(11)	SCREW +PTPWH 2.6 X 8	4
42	2-625-537-(01)	YOKE (S), CHUCKING	1
43	1-452-493-(21)	MAGNET	1
44	2-625-541-(01)	DAMPER (S)	1
45	2-626-002-(01)	PULLEY (G), CHUCKING	1
46	X-2625-379-(01)	CHASSIS A'SSY (G), SUB	1
47	2-625-539-(01)	SPRING (S)	4
48	2-644-410-(02)	WASHER BASED SCREW	4
49	KSM-2101ABM	DRIVE UNIT	1
50	2-625-279-(01)	SCREW +B2.6 X 16	2
51	3-464-123-(02)	SPACER	2
52	2-626-010-(01)	CHASSIS (G), OUTSERT MAIN	1
53	3-319-501-(51)	SCREW +PTPWH 2.6 X 16	1
54	2-626-003-(02)	GEAR (G), DRIVE	1
55	2-626-005-(03)	CAM (G), CONTROL	1
56	1-572-086-(11)	SWITCH, LEAF	2
57	1-564-721-(11)	PIN, CONNECTOR 5P	1
58	1-640-523-(11)	PC BOARD, LOADING	1
59	X-2625-117-(01)	MOTOR A'SSY, LOADING	1
60	2-625-999-(01)	GEAR (G), MIDWAY	1
61	2-625-997-(01)	PULLEY (G) LOADING	1
62	3-653-387-(01)	BELT, LM	1

ELECTRICAL PARTS LIST

MAIN PCB ASSEMBLY

Ref. No.	Part No.	Description
<u>PC BOARD</u>		
		PCB, NAD 512 - No Components
*AH △	1721-150A-0000	PCB Assembly
*C,B,B1	MI-21150-01-S	PCB Assembly
	MI-21150-02-S	PCB Assembly
<u>ICs</u>		
Q101	3130-4180-0	IC CXA1081M CD Play RF Amp
Q102	3130-4190-0	IC CXA1082BQ CD Play Servo
Q103	3130-4200-0	IC CXD1167Q CD DSP
Q104	3130-4210-0	IC CXP1011Q 64PIN QFP
Q105	3130-4240-0	IC MN6474AM D/A Converter
Q201-204	3130-2430-0	IC NE5532 Dual Op Amp
Q501	3130-3030-0	IC LM7815CT Regulator
Q502	3130-3020-0	IC LM7915CT Regulator
Q505	3130-4230-0	IC M5290P Regulator
Q507	3130-4170-0	IC TA7256P Dual Op Amp
Q601	3130-4150-0	IC TMS70CT40 C25311NF CC-01
Q701	3130-4160-0	IC TC74HC00AP 2-Input NAND
U601	481X-1610-3	I.R. Receiver Sony BX1610-52
<u>TRANSISTORS</u>		
Q106	N4851015Y-5	TR. 2SA1015-Y HFE 100-2
Q107-109	N4851815Y-5	TR. 2SC1815-Y HFE 120-2
Q110	4860-0960-5	TR. 2SB1013 RL
Q205-210	N48600770-5	TR. 2SC2878 (A,B) RL
Q211	N4851015Y-5	TR. 2SA1015-Y HFE 100-2
Q503	4860-0970-5	TR. 2SB1375 RL TSB
Q504	4860-0980-5	TR. 2SD2012 RL TSB
Q508-511	N4851015Y-5	TR. 2SA1015-Y HFE 100-2
Q602	N4851815Y-5	TR. 2SC1815-Y HFE 120-2
Q603	N4851015Y-5	TR. 2SA1015-Y HFE 100-2
Q604	4860-0940-5	TR. 2SD1225MR RL
Q605	4860-0950-5	TR. 2SB909MR RL
Q606	4860-0940-5	TR. 2SD1225MR RL
Q607	4860-0950-5	TR. 2SB909MR RL
Q608	4860-0940-5	TR. 2SD1225MR RL
Q609	4860-0950-5	TR. 2SB909MR RL
<u>DIODES</u>		
D101	N24601030-0	LCD Display
D201, 202	4837-4C20-2	Diode Zener 1/2W 5.0-5.2V
D501-504	4804-0020-1	Diode Rectifier 1N4002
D601-615	4804-1480-2	Diode 1N4148
<u>FUSES</u>		
F501*AH △	5120-0010-0	Fuse 250V 800mA 5X20mm UL/CSA
F501*C,B △	5120-0011-0	Fuse 250V 800mA 5X20mm SEMKO
FH501, FH502	4131-9131-0	Fuse Holder 5mm Dia
F502*AH △	5120-0010-0	Fuse 250V 800mA 5X20mm UL/CSA
F502*C,B △	5120-0011-0	Fuse 250V 800mA 5X20mm SEMKO
<u>COILS</u>		
T501 △	1806-2117-1	Transformer (PT-57E25-R1)
T701	1802-0450-0	Digital coil 015-910-27BB

MECHANISM EXPLODED VIEW

KSL-2101ABM

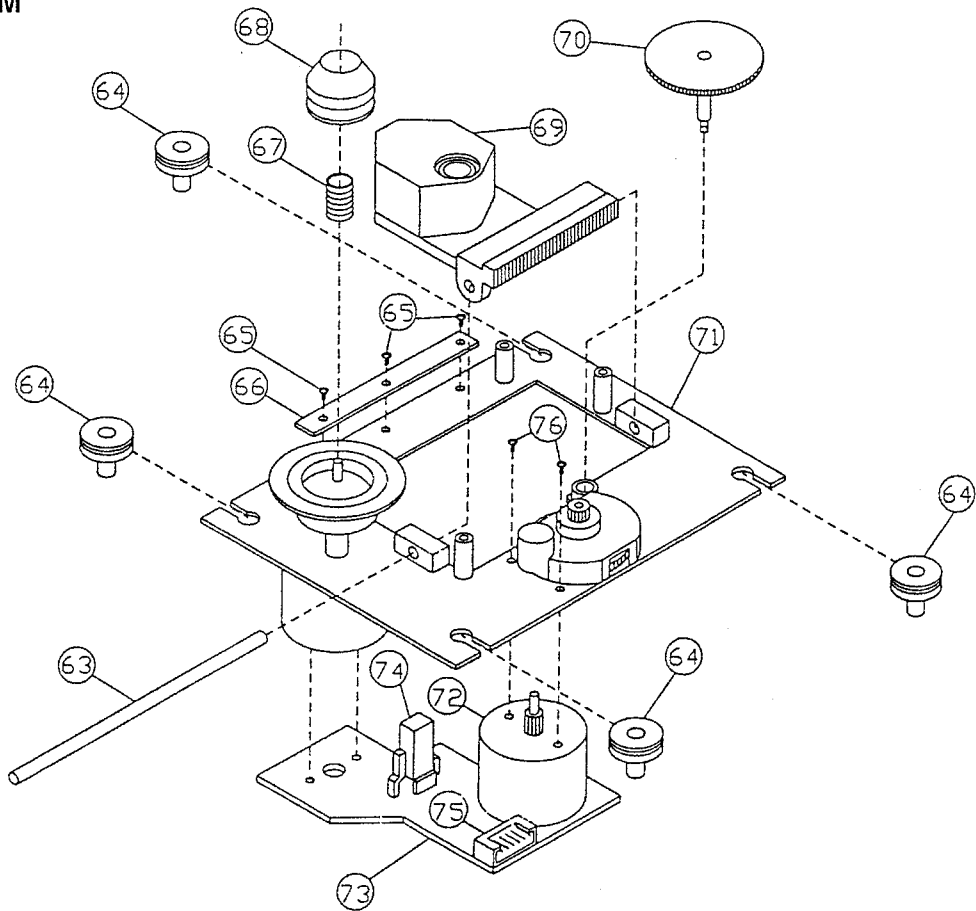

KSL-2101ABM SERVICE PARTS LIST

NO	PART NO	DESCRIPTION	Q'TY
63	2-625-464-(01)	SHAFT (S), SLED	1
64	2-625-538-(01)	INSULATOR (S)	4
65	2-641-386-(01)	SCREW (2 X 5), TAPPING (S)	3
66	2-625-625-(01)	REINFORCEMENT (S)	1
67	2-625-465-(01)	SPRING (S) COMPRESSION	1
68	2-625-477-(01)	RING (LO) (S), CENTER	1
69	8-848-127-(31)	PICK UP KSS-210A (S) (RP)	1
70	2-625-462-(01)	GEAR (A) (S)	1
71	X-2625-133-(2)	CHASSIS A'SSY (MB), TT WITH DISC MOTOR & TABLE	1
72	X-2625-132-(1)	GEAR A'SSY (MB), MOTOR	1
73	X-639-678-(12)	PC BOARD, MOTOR (GP) (S)	1
74	1-572-085-(12)	SWITCH LEAF	1
75	1-564-722-(11)	PIN CONNECTOR GP	1
76	7-621-255-(15)	SCREW +P2 X 3	2

Ref. No.	Part No.	Description
CAPACITORS		
C101	157F-105M-5	CE 50V 1 μ F +/-20%
C102	157F-475M-5	CE 50V 4.7 μ F +/-20%
C106	153F-104J-5	CM 50V 0.1 μ F +/-5%
C107	157F-106M-5	CE 50V 10 μ F +/-20%
C108	153F-104J-5	CM 50V 0.1 μ F +/-5%
C109	157F-335M-5	CE 50V 3.3 μ F +/-20%
C110	153F-473J-5	CM 50V 0.047 μ F +/-5%
C111	153F-104J-5	CM 50V 0.1 μ F +/-5%
C113	157C-107M-5	CE 10V 100 μ F +/-20%
C115	153F-333J-5	CM 50V 0.033 μ F +/-5%
C116	157F-474M-5	CE 50V 0.47 μ F +/-20%
C118	157F-474M-5	CE 50V 0.47 μ F +/-20%
C120	153F-333J-5	CM 50V 0.033 μ F +/-5%
C121	157C-107M-5	CE 10V 100 μ F +/-20%
C122	153F-333J-5	CM 50V 0.033 μ F +/-5%
C125	157C-107M-5	CE 10V 100 μ F +/-20%
C127	157C-107M-5	CE 10V 100 μ F +/-20%
C128	153F-223J-5	CM 50V 0.022 μ F +/-5%
C129	157C-107M-5	CE 10V 100 μ F +/-20%
C201	153F-473J-5	CM 50V 0.047 μ F +/-5%
C206-208	153F-473J-5	CM 50V 0.047 μ F +/-5%
C209-212	158F-201J-5	CP 50V 200pF +/-5%
C217-220	159F-472J-5	CP 50V 4700pF +/-5%
C221, 222	159F-102J-5	CP 50V 1000pF +/-5%
C223, 224	159F-393J-5	CP 50V 0.039 μ F +/-5%
C225, 226	159F-472J-5	CP 50V 4700pF +/-5%
C227, 228	158F-201J-5	CP 50V 200pF +/-5%
C233-236	153F-103J-5	CM 50V 0.01 μ F +/-5%
C237, 238	153F-222J-5	CM 50V 2200pF +/-5%
C239	157C-107M-5	CE 10V 100 μ F +/-20%
C240-243	157C-337M-5	CE 10V 330 μ F +/-20%
C244	157C-107M-5	CE 10V 100 μ F +/-20%
C246-249	159F-474J-5	CP 50V 0.47 μ F +/-5%
C501, 502	157E-228M-5	CE 25V 2200 μ F +/-20%
C503, 504	157D-108M-5	CE 16V 1000 μ F +/-20%
C505	153R-223K-5	CM 250V 0.022 μ F +/-10%
C506 \triangle	N89100049-0	Cap. 400V 4700pF DE7150 F472MVA1KC
C507, 508	157D-337M-5	CE 16V 330 μ F +/-20%
C510	157C-476M-5	CE 10V 47 μ F +/-20%
C511-518	157D-107M-5	CE 16V 100 μ F +/-20%
C519	157F-474M-5	CE 50V 0.47 μ F +/-20%
C520	157F-106M-5	CE 50V 10 μ F +/-20%
C521-523	157C-107M-5	CE 10V 100 μ F +/-20%
C525-526	157D-477M-5	CE 16V 470 μ F +/-20%
C527-530	153F-473J-5	CM 50V 0.047 μ F +/-5%
C601	157F-105M-5	CE 50V 1 μ F +/-20%
C612	157F-335M-5	CE 50V 3.3 μ F +/-20%
C613	157C-107M-5	CE 10V 100 μ F +/-20%
C701	157C-226M-5	CE 10V 22 μ F +/-20%
RESISTORS		
R203-206	4711-103A-C	RMF 1/8W 10k Ohm +/-1%
R211-214	4711-273A-C	RMF 1/8W 27k Ohm +/-1%
R215-218	4711-473A-C	RMF 1/8W 47k Ohm +/-1%
R219, 220	4711-162A-C	RMF 1/8W 1.6k Ohm +/-1%
R221, 222	4711-302A-C	RMF 1/8W 3k Ohm +/-1%
R223, 224	4711-681A-C	RMF 1/8W 680 Ohm +/-1%
R225, 226	4711-472A-C	RMF 1/8W 4.7k Ohm +/-1%
R227, 228	4711-122A-C	RMF 1/8W 1.2k Ohm +/-1%

Ref. No.	Part No.	Description
R229, 230	4711-362A-C	RMF 1/8W 3.6k Ohm +/-1%
R231, 232	4711-391A-C	RMF 1/8W 390 Ohm +/-1%
R235, 238	4711-472A-C	RMF 1/8W 4.7k Ohm +/-1%
R507-514	4717-221J-L	RMF 1/2W 220 Ohm +/-5%
R516, 517	4717-680J-L	RMF 1/2W 68 Ohm +/-5%
<u>VARIABLE RES.</u>		
RV101	4756-1026-3-06	SVR 1k H3 7 x 7.6 RH0615C
RV102	4756-2246-3-06	SVR 220k H3 7 x 7.6 RH0615C
RV103-105	4756-2236-3-06	SVR 22k H3 7 x 7.6 RH0615C
<u>SWITCHES</u>		
S501 △	N52003151-0	Power switch (SPPL-005)
S601-611	N52003011-0	Tact switch 4-pin
<u>RCA JACKS</u>		
P201	2103-9202-0	2P RCA R/W (GOLD PLATE)
P601	N21037402-0	RCA 2POS RJ-1020-050 (YELLOW)
P701	2113-0500-0	1P RCA SOCKET (BLACK)
<u>MISCELLANEOUS</u>		
D505, 506	2450-0706-0	Lamp 16V 92mA 5X10mm Radial
Z201	2300-1210-0	Crystal 33.8688MHz
Z601	N27030120-0	Ceramic Resonator CSA 4.91
Z701	2704-0060-0	EMC Filter DSS31055B271M

PACKING DIAGRAM

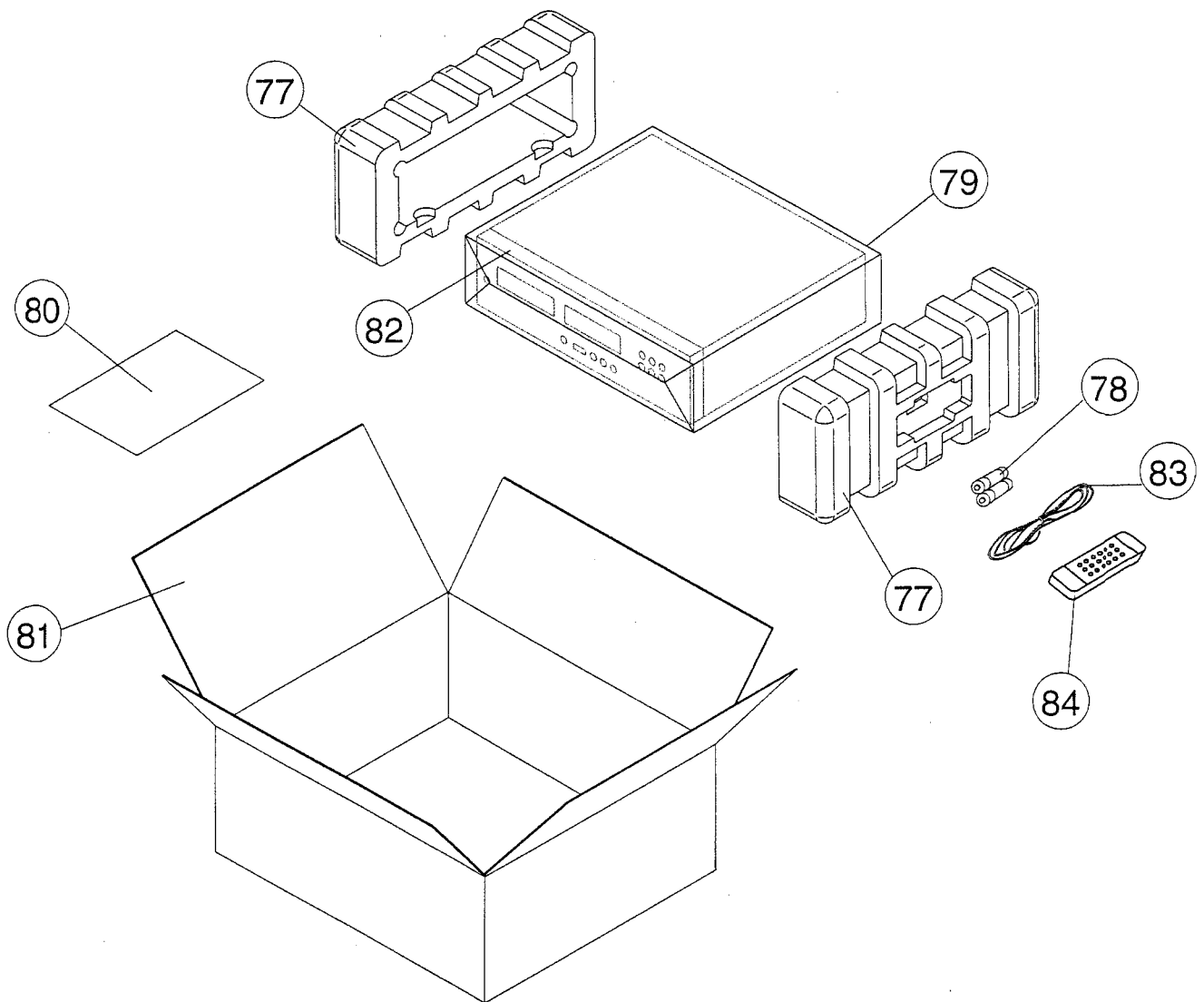

ITEM	PARTS NO.	DESCRIPTION	Q'TY
77	1490-1813-0	POLYFOAM END-CAP	2
78	4060-0520-0	BATTERIES	2
79	N14971332-1	POLYBAG	1
80	N43013586-1	OWNERS MANUAL	1
81	N14763401-0	CARTON BOX	1
82	1497-1452-0	EPE BAG	1
83	N21037302-0	RCA CABLE	1
84	8900-1060-0	REMOTE CONTROL HAND SET	1

Proprietary information for servicing purposes only. The information herein may not be used commercially without the prior written agreement of NAD Electronics Ltd., London, England.

SERVICE MANUAL

© NAD 1995

512
COMPACT
DISC PLAYER

NAD ELECTRONICS
LONDON