

SERVICE MANUAL

NAD

SERVICE SAFETY PRECAUTIONS (UL)

1. Use exact replacement parts for critical locations marked "⚠".
2. Return lead dress to original position and re-install protective covers.
3. Before returning to customer, test for shock hazard; use either method A or B:
 - A. Leakage test "cold":
 1. Unplug the AC cord; turn power switch ON.
 2. Connect one lead of High Voltage Insulation Tester to both prongs of the AC plug.
 3. Touch other lead to all exposed metal parts.
 4. Impedance measurement must be 0.3-5.0 Megohms.
 - B. Leakage test. "live" :
 1. Plug unit directly into the AC outlet; do not use isolation transformer.
 2. Connect one lead of the Leakage Current Tester to earth ground.
 3. Touch other lead to all exposed metal parts.
 4. Leakage measurement must be less than 0.5 milliamps.

317

STEREO INTEGRATED AMPLIFIER

317

STEREO INTEGRATED AMPLIFIER

SERVICE SAFETY PRECAUTIONS

1. Replacing the fuses

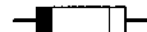

This symbol located near the fuse indicates that the fuse used is fast operating type. For continued protection against fire hazard, replace with same type fuse. For fuse rating refer to the marking adjacent to the symbol.

Reference No	Part Number	Description
F501*AH	N51007030-1A	Fuse 7A 125V Time Lag LBC (UL/CSA)
F501*B,C	N51002530-1B	Fuse 2.5A 250V Time Lag LBC (SEMKO/VDE)
F502*AH	5120-0036-0	Fuse 100mA 250V Medium Time Lag LBC (UL/CSA)
F502*B,C	5120-0035-0	Fuse 100mA 250V Time Lag LBC (SEMKO/VDE)

NOTE :

- <*AH > : USA, CANADIAN MODEL ONLY.
- <*B > : UK MODEL ONLY.
- <*C > : EUROPEAN MODEL ONLY.

2. Safety-check out

(Only U.S.A. model)

After correcting the original service problem perform the following safety check before releasing the set to the customer.

Connect the insulating-resistance tester between the plug of power supply cord and the screw on the back panel.

Specifications : 3.3 Mohm \pm 10% at 500V.

CONTENTS

DESCRIPTION	PAGE
SPECIFICATIONS	4-5
REAR PANEL / FRONT PANEL VIEW.....	6
WIRING DIAGRAM	7-8
DISASSEMBLY INSTRUCTIONS	9
ALIGNMENT POINTS DIAGRAM / PROCEDURE	10
PCB LAYOUT	11-13
SCHEMATIC DIAGRAM	14-19
IC BLOCK DIAGRAM	20-21
EXPLODED VIEW	22
EXPLODED VIEW PARTS LIST	23-24
ELECTRICAL PARTS LIST	25-30
PACKING DIAGRAM / PACKING LIST.....	31

SPECIFICATIONS

POWER AMPLIFIER SECTION

CONTINUOUS AVERAGE POWER OUTPUT INTO 8 OHMS (Min. power per channel, 20 Hz - 20 kHz, both channels driven, with no more than rated distortion)	80 W (19 dBW)
Rated Distortion THD (20 Hz - 20 kHz)	0.03%
Clipping power at 8 ohms (Maximum continuous power per channel).	95 W
IHF dynamic headroom at 8 ohms	+1.4 dB
IHF dynamic power (Maximum short term power per channel)	
8 ohms:	110 W (20.4 dBW)
4 ohms:	180 W (22.6 dBW)
2 ohms:	250 W (24 dBW)
Slew rate	> 60 V / μsec
Damping factor at 50 Hz 8 ohms:	200
Input Impedance	60 kohms + 500 pF
input sensitivity (for rated output into 8 ohms)	0.9 V
Voltage gain	x 28.3 (29 dB)
Frequency response 20 Hz - 20 kHz	± 0.2 dB - 3 dB at 2 Hz / 100 kHz
Signal / Noise ratio, A-weighted	96 dB ref. 1 W 115 dB ref. rated power

BRIDGED (MONOPHONIC) MODE

CONTINUOUS AVERAGE POWER OUTPUT INTO 8 OHMS (Min. power per channel, with no more than rated distortion)	240 W (23.8 dB)
IHF dynamic headroom at 8 ohms	+ 1.8 dB
IHF dynamic power 8 ohms:	360 W (25.6 dBW)
4 ohms:	500 W (27 dBW)
Input sensitivity (for rated output into 8 ohms)	775 mV

PREAMPLIFIER SECTION

<u>LINE LEVEL INPUTS</u> (CD, Video, Auxiliary, Tuner, Tape1, Tape2)	
Input impedance (R and C)	20 kohms + 450 pF
Input sensitivity (ref. 0.5 V)	80 mV
Signal/ Noise ratio, A-weighted	80 dB ref. 1 W
Frequency response, 20 Hz - 20 kHz	± 0.2 dB
Voltage gain	16 dB
THD + SMPTE + IHF I.M.	0.01%
<u>LINE LEVEL OUTPUTS</u>	
Preamp output impedance	220 ohms
Tape output impedance	Source Z + 2 kohms
Headphones output impedance	120 ohms
Maximum output level	preamp-out: > 12 V tape-out: > 10 V headphones-out: > 8 V into 600 ohms > 250 mV into 8 ohms
<u>CONTROLS</u>	
Treble	± 7 dB at 10 kHz
Bass	± 10 dB at 50 Hz

DIMENSIONS AND WEIGHTS

Net Weight	12 kg (26.4 lb)
Shipping Weight	13.6 kg (29.92 lb)
Dimensions (Width x Height x Depth)	435mm x 130mm x 380mm

REAR PANEL / FRONT PANEL VIEW

FRONT PANEL

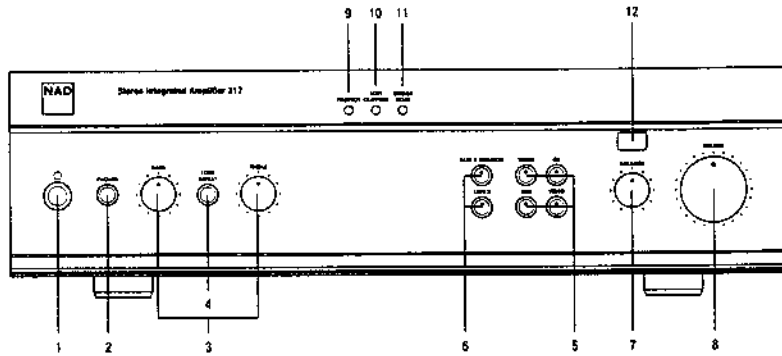

1. POWER SWITCH
2. HEADPHONE SOCKET
3. BASS & TREBLE CONTROLS
4. TONE DEFEAT SWITCH
5. INPUT SELECTORS
6. TAPE 1 MONITOR/ TAPE 2

7. BALANCE CONTROL
8. VOLUME CONTROL
9. PROTECT INDICATOR
10. SOFT CLIPPING INDICATOR
11. BRIDGE MODE INDICATOR
12. INFRA-RED SENSOR

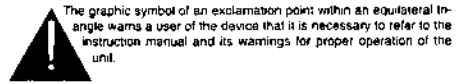
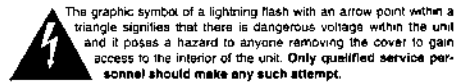

REAR PANEL

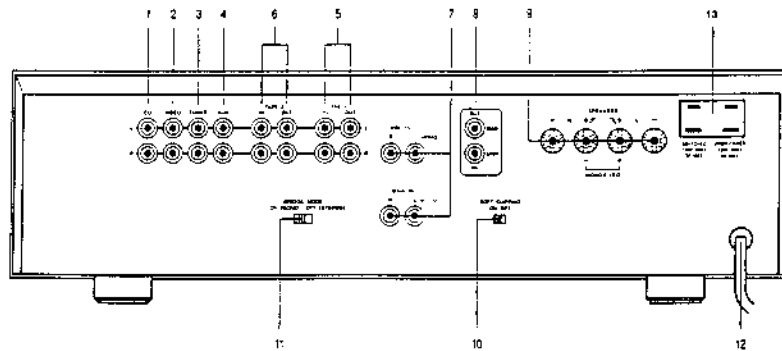

1. CD INPUT
2. VIDEO SOUND INPUT
3. TUNER INPUT
4. AUXILIARY INPUT
5. TAPE 1 INPUT/OUTPUT
6. TAPE 2 INPUT/OUTPUT
7. PREAMP OUT, MAIN IN

8. NAD LINK INPUT/OUTPUT
9. SPEAKER TERMINALS
10. SOFT CLIPPING SWITCH
11. BRIDGE MODE SWITCH
12. AC LINE CORD
13. AC OUTLETS (ONLY IN 120 V MODEL)

DISASSEMBLY INSTRUCTIONS

1. Remove machine screws M4.0 x 6.0 (① to ⑥) from the side panels. Remove tapping screw 3.0 x 8.0 (⑦ to ⑧) from the back panel. Refer to **Figure No. 1**.

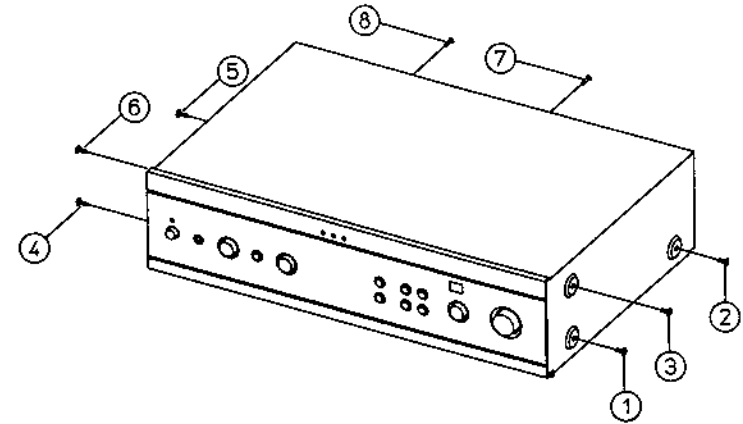

Figure No. 1.

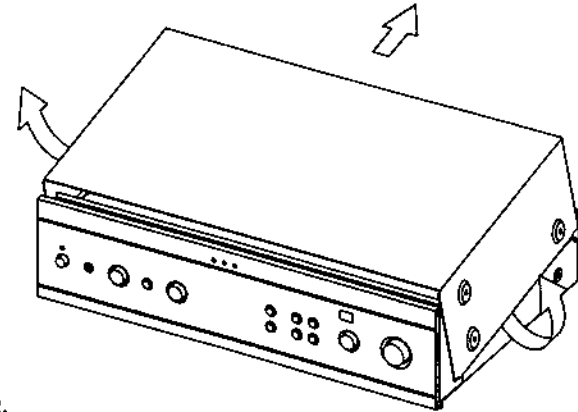
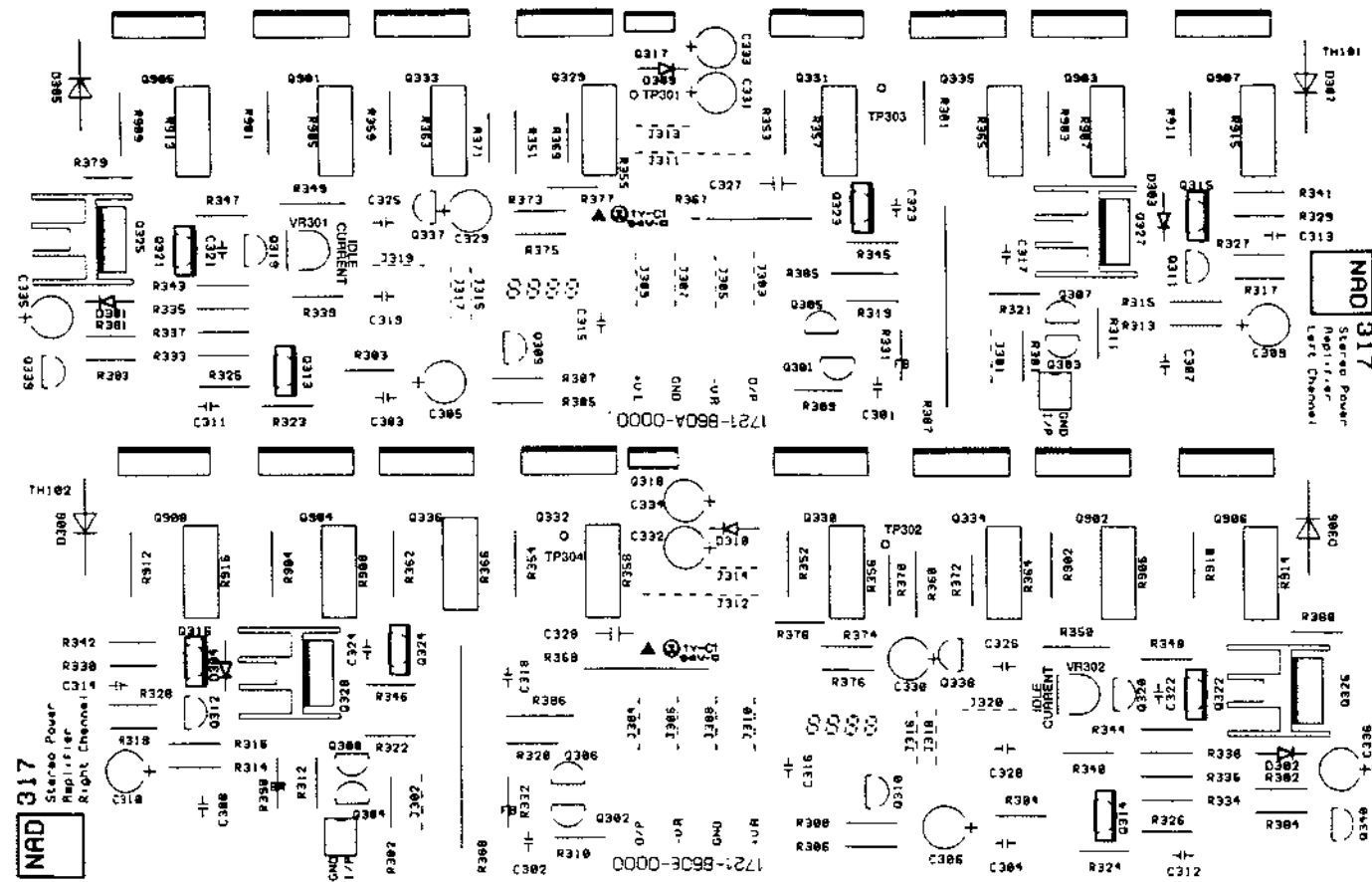

Figure No. 2.

2. Pull both sides of the TOP COVER slightly outwards, tilt approximately 35° and then move in the direction shown in **Figure No. 2**.

ALIGNMENT POINTS DIAGRAM / PROCEDURES

A. ALIGNMENT POINTS



B. IDLE CURRENT ALIGNMENT (NO SIGNAL, NO LOAD)

1. Connect a DC millivoltmeter to TP301 and TP303, and adjust VR301 for 20 ± 1.5 mV reading on meter.
2. Connect a DC millivoltmeter to TP302 and TP304, and adjust VR302 for 20 ± 1.5 mV reading on meter.
3. Leave power "on" for a minimum of 5 minutes, and check 1 and 2 for correct reading.

PCB LAYOUT

PSU PCB

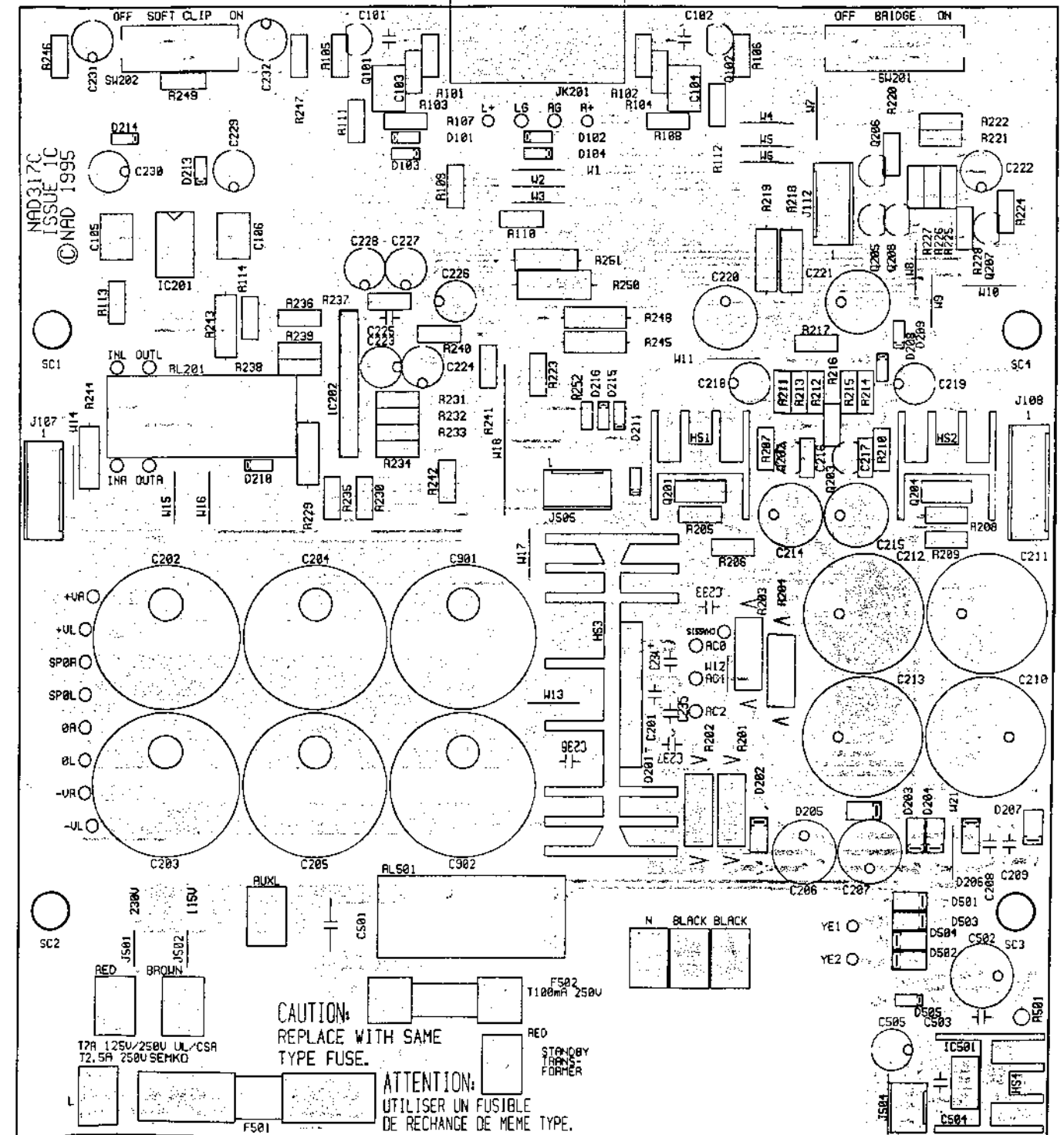

FRONT PANEL PCB

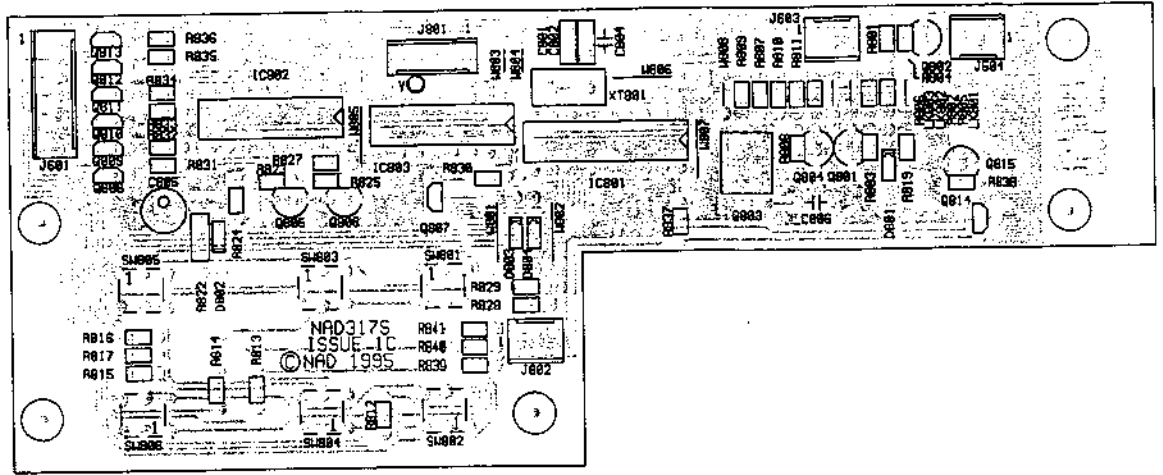

TONE CONTROL PCB

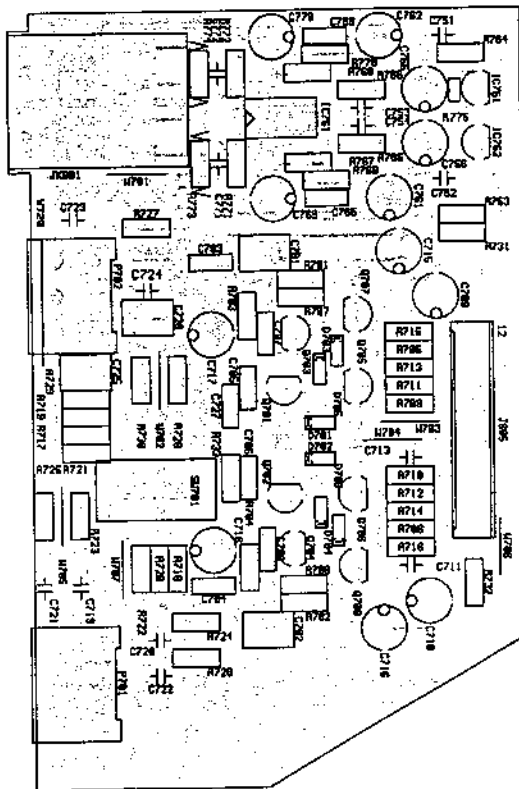

VOLUME PCB

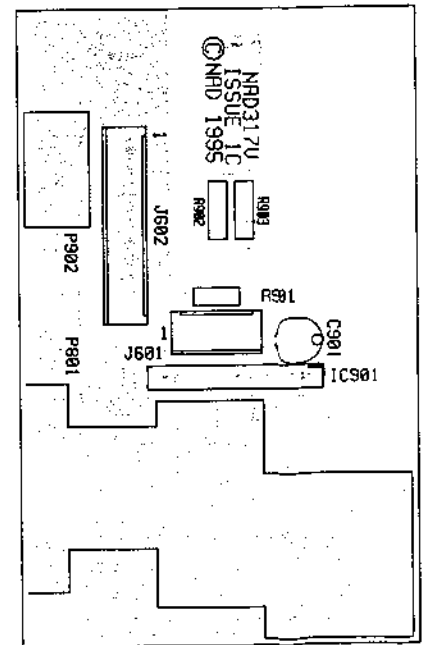

SPEAKER TERMINAL PCB

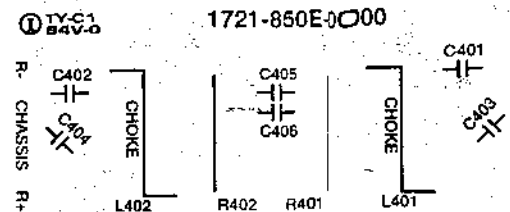

POWER SWITCH PCB

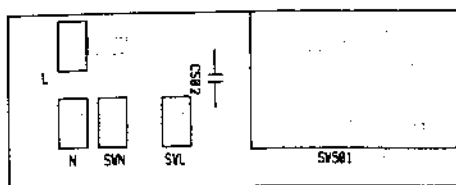

INPUT, STANDBY LED & LED PCBs

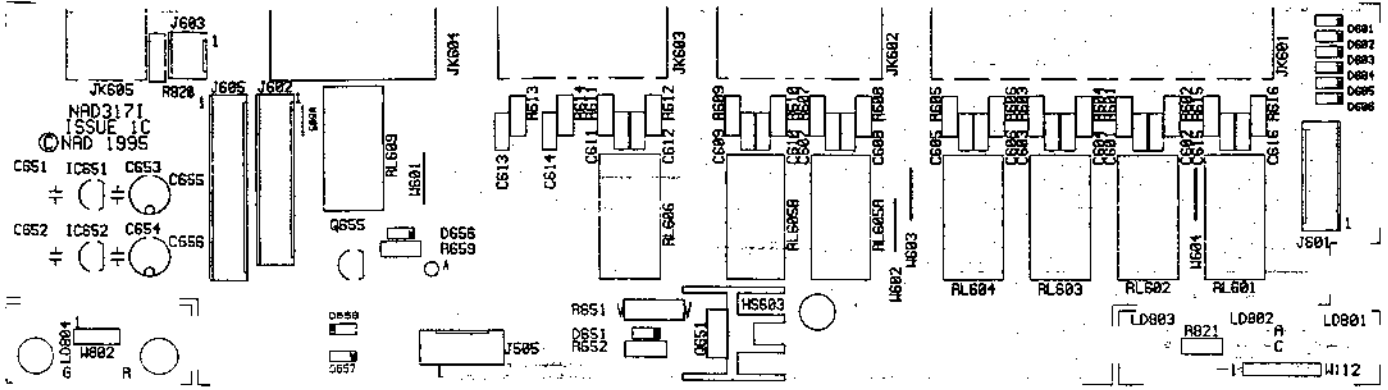

POWER AMPLIFIER LEFT CHANNEL PCB

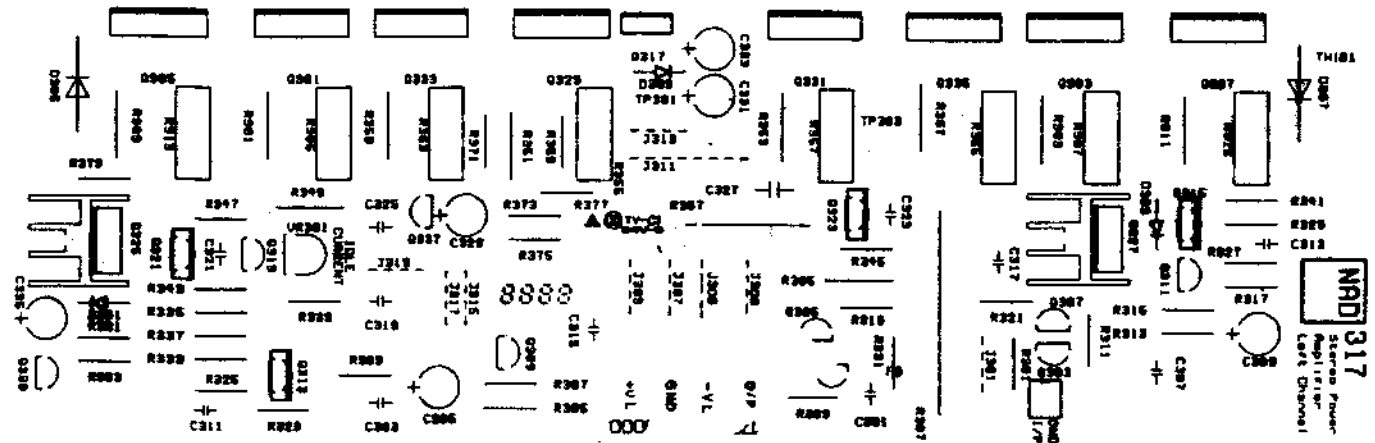

POWER AMPLIFIER RIGHT CHANNEL PCB

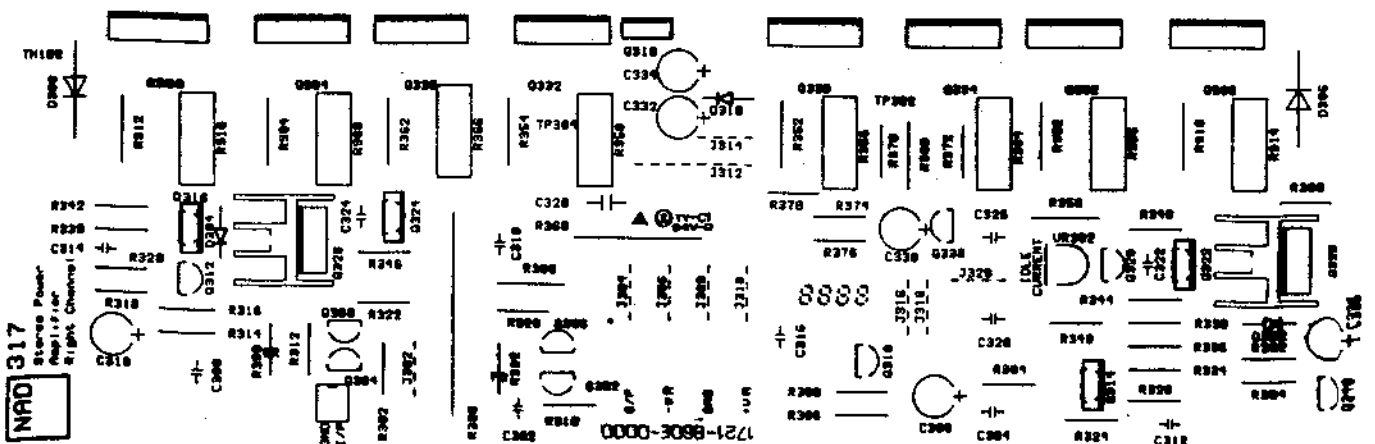

SCHEMATIC DIAGRAM PSU

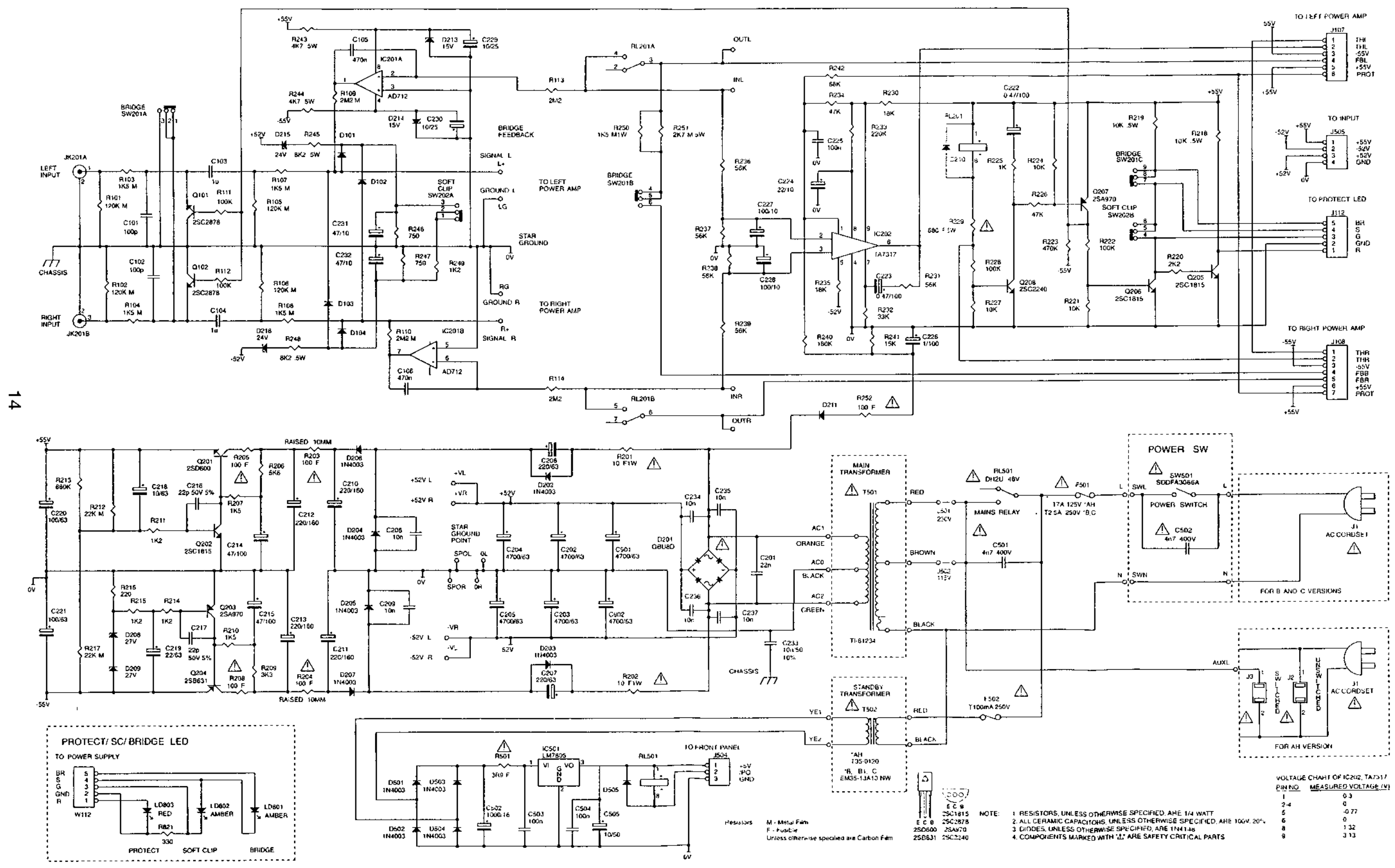

14

VOLTAGE CHART OF IC202, TA7317

PIN NO.	MEASURED VOLTAGE (V)
1	0.3
2-4	0
5	-0.77
6	0
8	1.32
9	3.13

- NOTE:
1. RESISTORS, UNLESS OTHERWISE SPECIFIED, ARE 1/4 WATT
 2. ALL CERAMIC CAPACITORS, UNLESS OTHERWISE SPECIFIED, ARE 100V, 20%
 3. DIODES, UNLESS OTHERWISE SPECIFIED, ARE 1N4148
 4. COMPONENTS MARKED WITH '!' ARE SAFETY CRITICAL PARTS

Resistors: M - Metal Film, F - Fusible, Unless otherwise specified are Carbon Film

Capacitors: C - Ceramic, P - Polyester, A - Aluminum Electrolytic, T - Tantalum Electrolytic, L - Leaded, S - Surface Mount

LEFT POWER AMPLIFIER

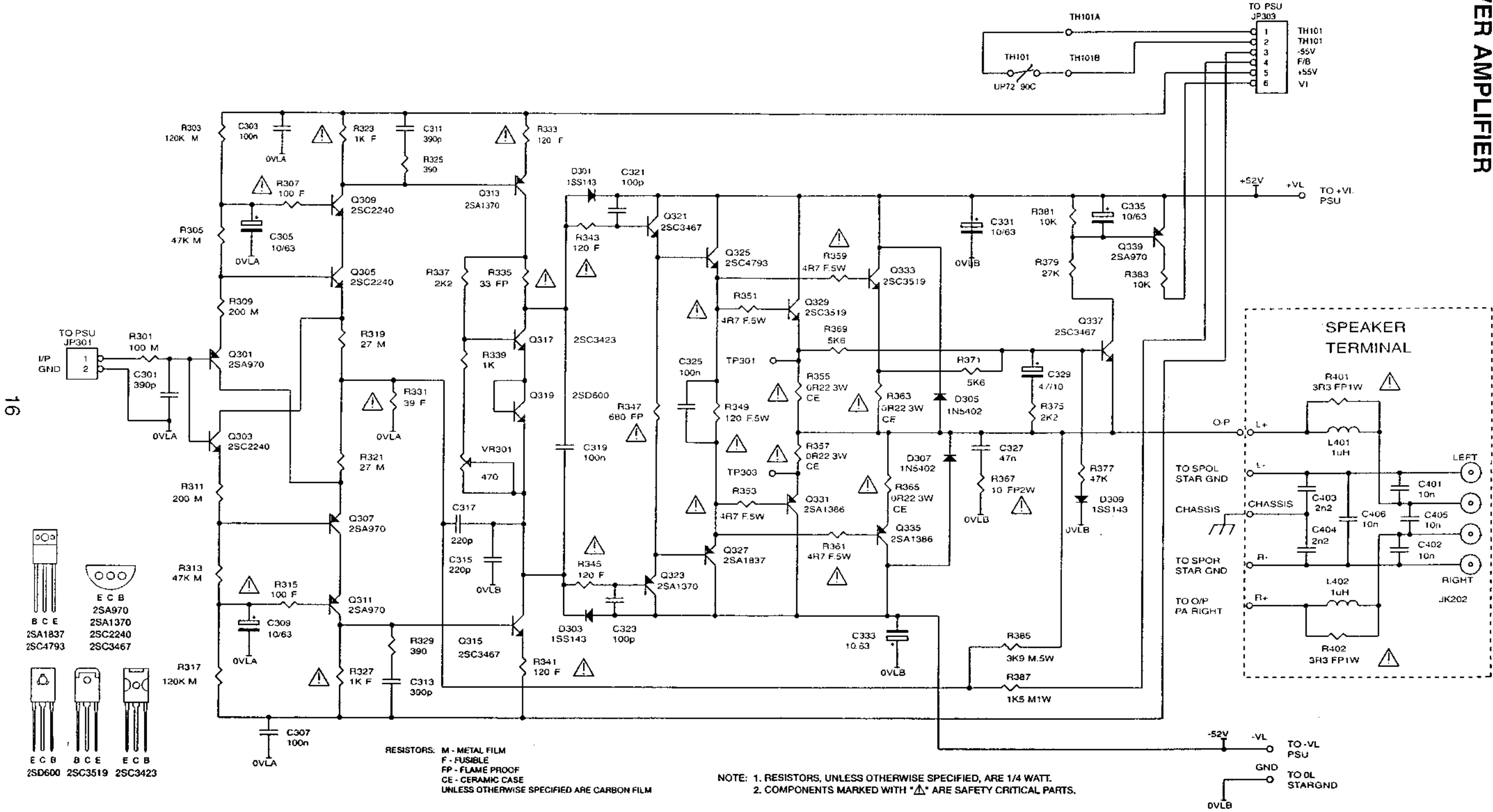

16

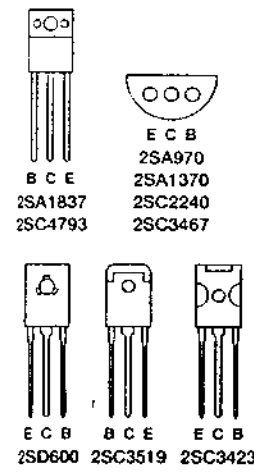

RESISTORS: M - METAL FILM
 F - FUSIBLE
 FP - FLAME PROOF
 CE - CERAMIC CASE
 UNLESS OTHERWISE SPECIFIED ARE CARBON FILM

NOTE: 1. RESISTORS, UNLESS OTHERWISE SPECIFIED, ARE 1/4 WATT.
 2. COMPONENTS MARKED WITH *Δ* ARE SAFETY CRITICAL PARTS.

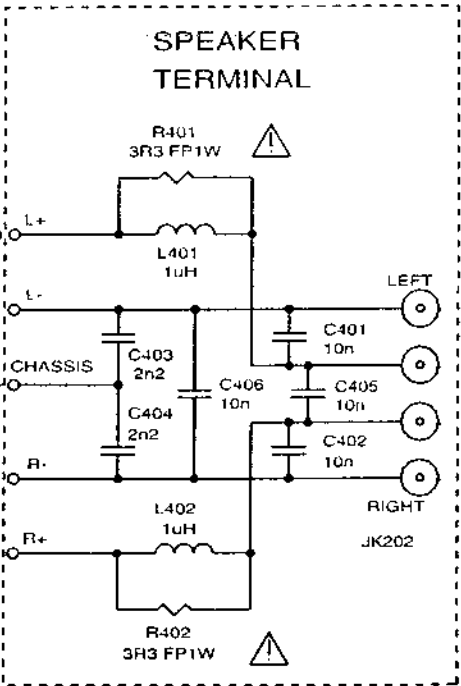
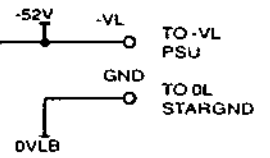

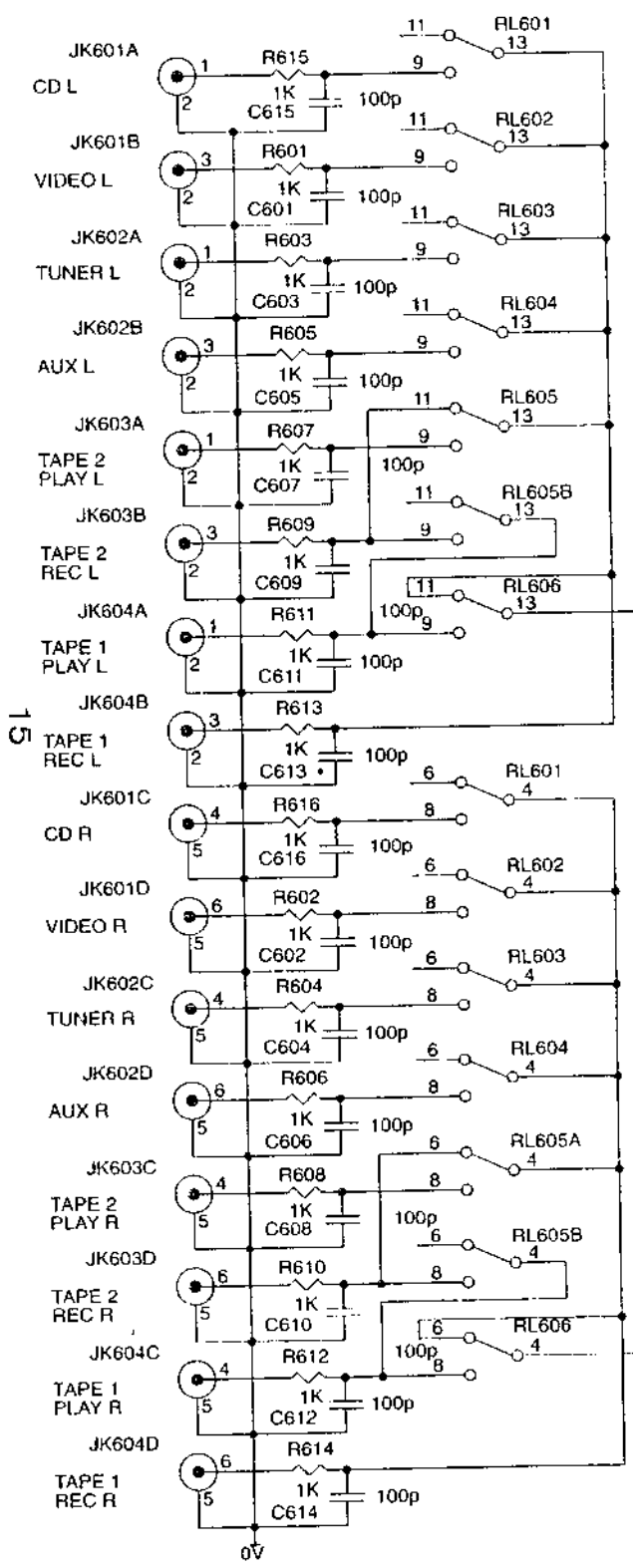

TO TONE CONTROLS

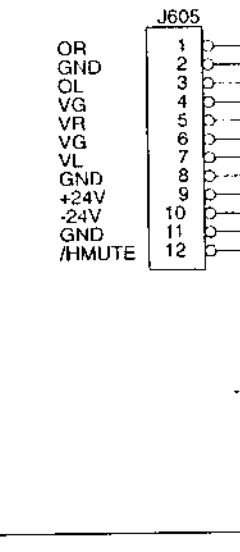

TO VOLUME CONTROL

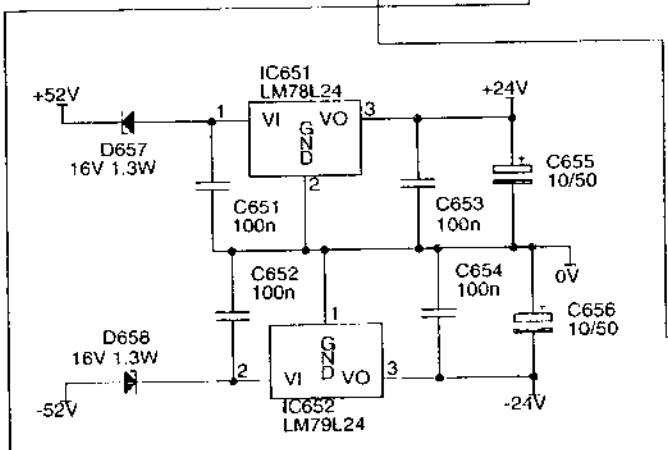
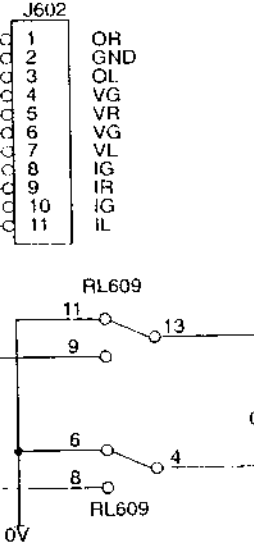

TO POWER SUPPLY

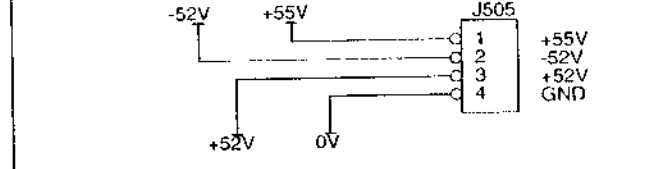

TO FRONT PANEL

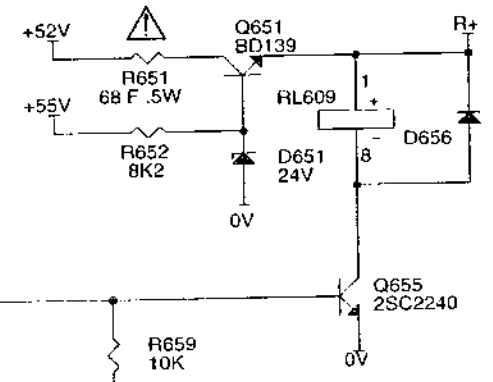
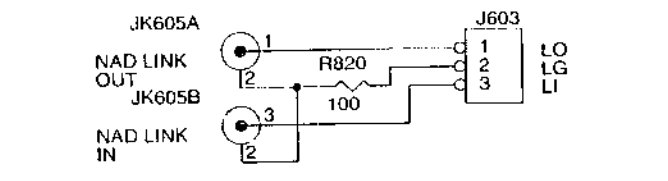

TO FRONT PANEL

TO FRONT PANEL

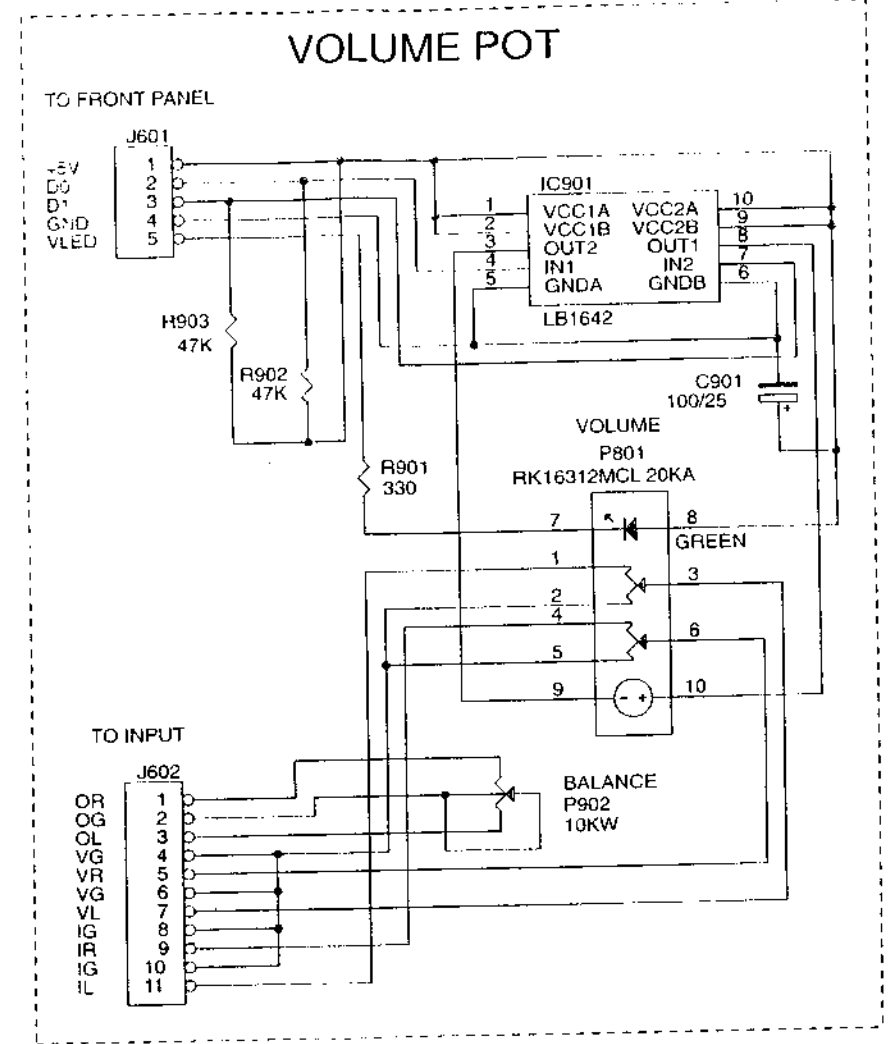
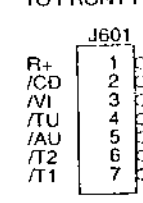

VOLUME POT

TO FRONT PANEL

TO INPUT

RESISTORS: F - FUSIBLE
UNLESS OTHERWISE SPECIFIED ARE CARBON FILM

- NOTE: 1. RESISTORS, UNLESS OTHERWISE SPECIFIED, ARE 1/4 WATT.
- 2. ALL CERAMIC CAPACITORS, UNLESS OTHERWISE SPECIFIED, ARE 50V, 5%.
- 3. DIODES, UNLESS OTHERWISE SPECIFIED, ARE 1N4148.
- 4. RELAYS, UNLESS OTHERWISE SPECIFIED, ARE GY-24W-K.
- 5. COMPONENTS MARKED WITH "▲" ARE SAFETY CRITICAL PARTS.

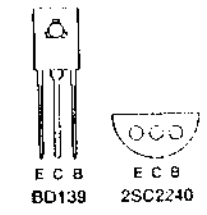

RIGHT POWER AMPLIFIER

17

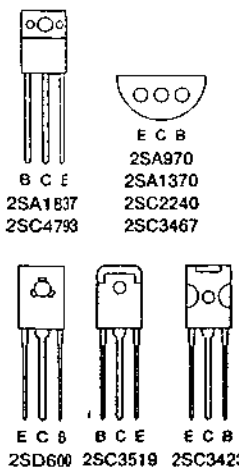
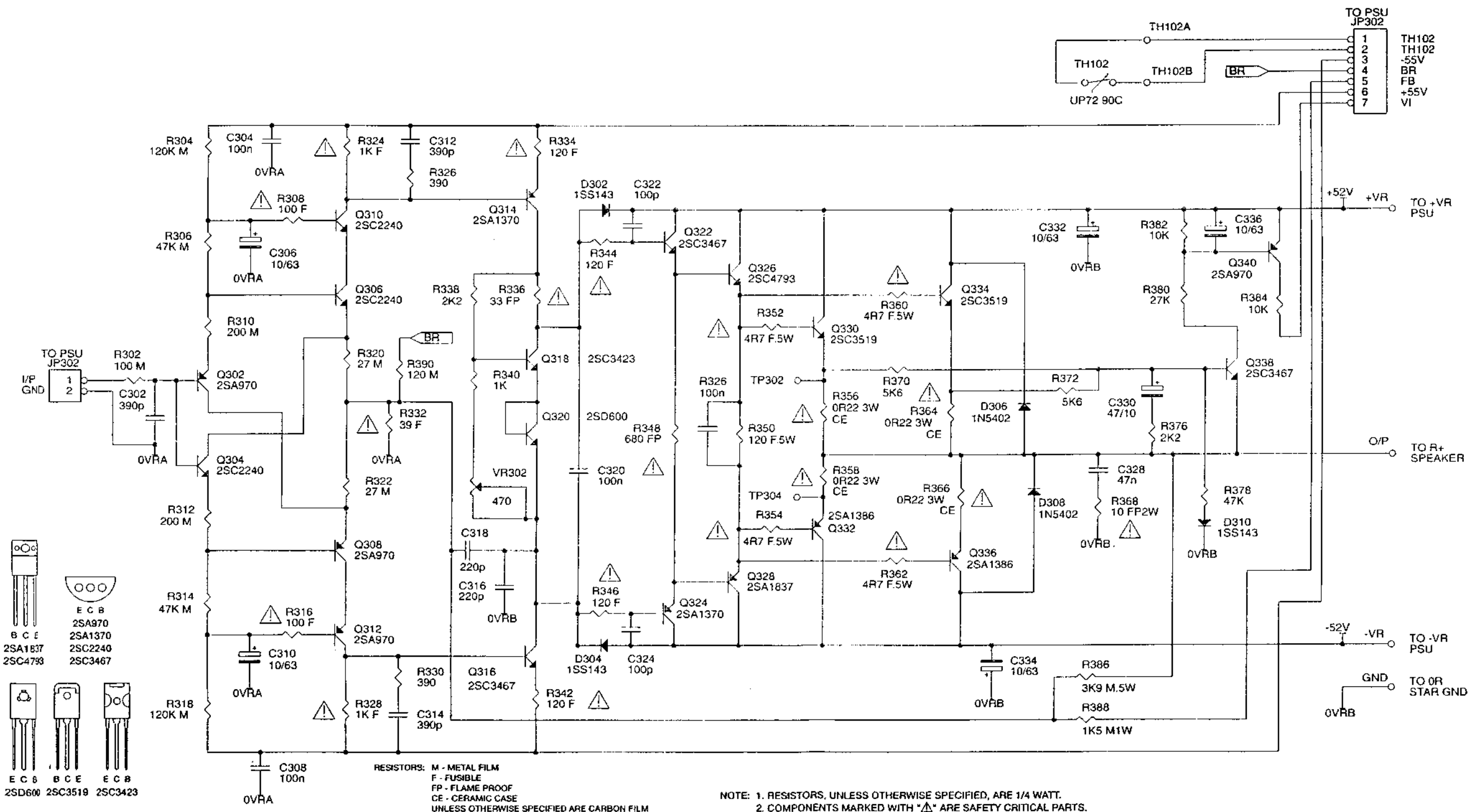

TONE CONTROL & HEADPHONE AMPLIFIER

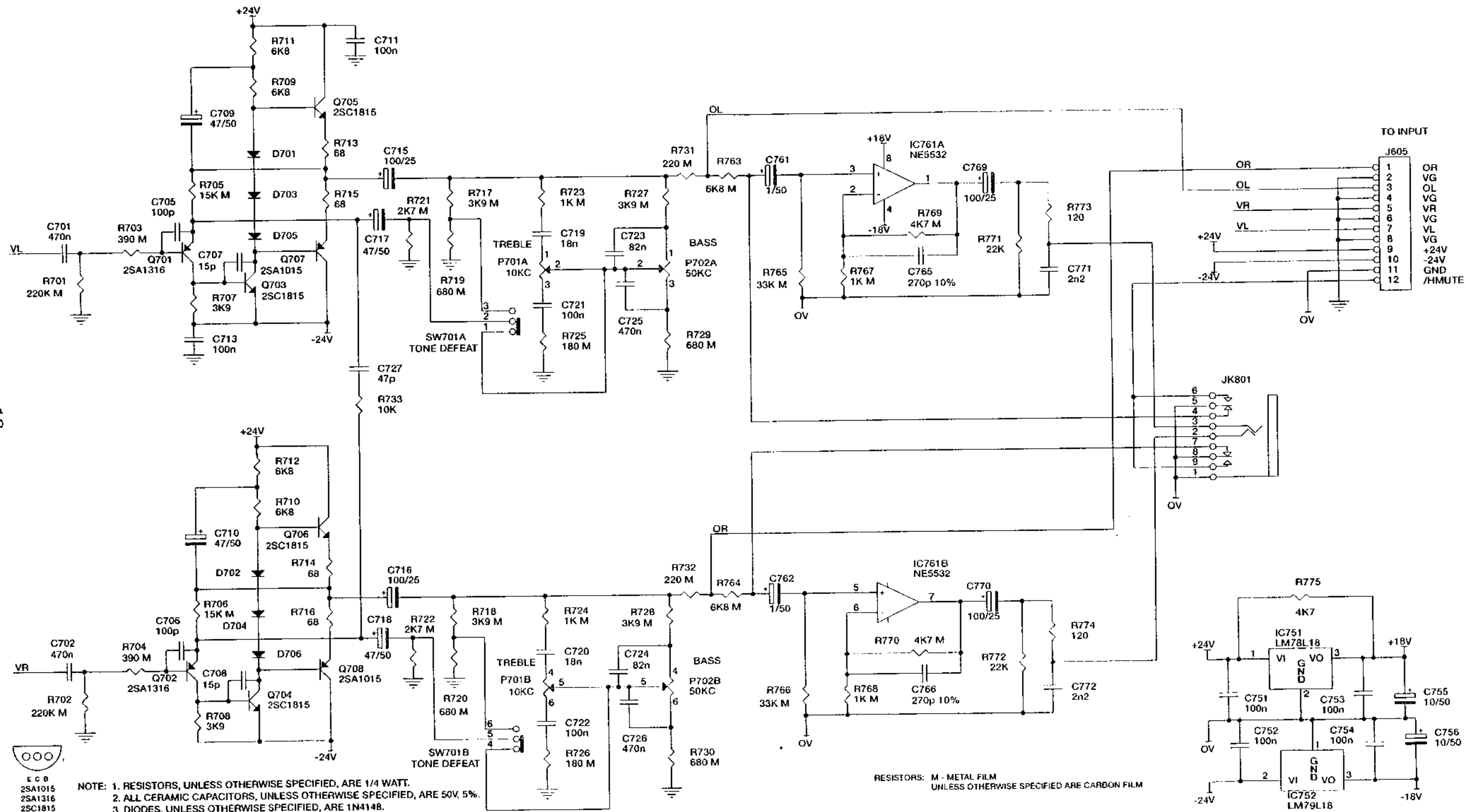

NOTE: 1. RESISTORS, UNLESS OTHERWISE SPECIFIED, ARE 1/4 WATT.
 2. ALL CERAMIC CAPACITORS, UNLESS OTHERWISE SPECIFIED, ARE 50V, 5%.
 3. DIODES, UNLESS OTHERWISE SPECIFIED, ARE 1N4148.

RESISTORS: M - METAL FILM
 UNLESS OTHERWISE SPECIFIED ARE CARBON FILM

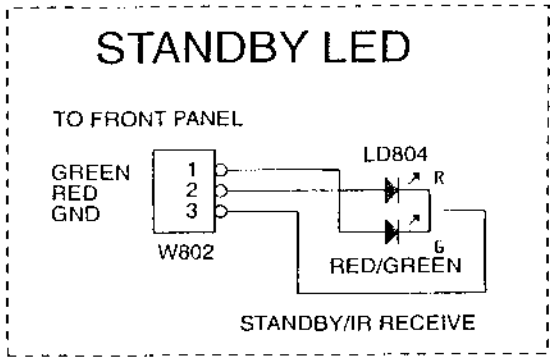
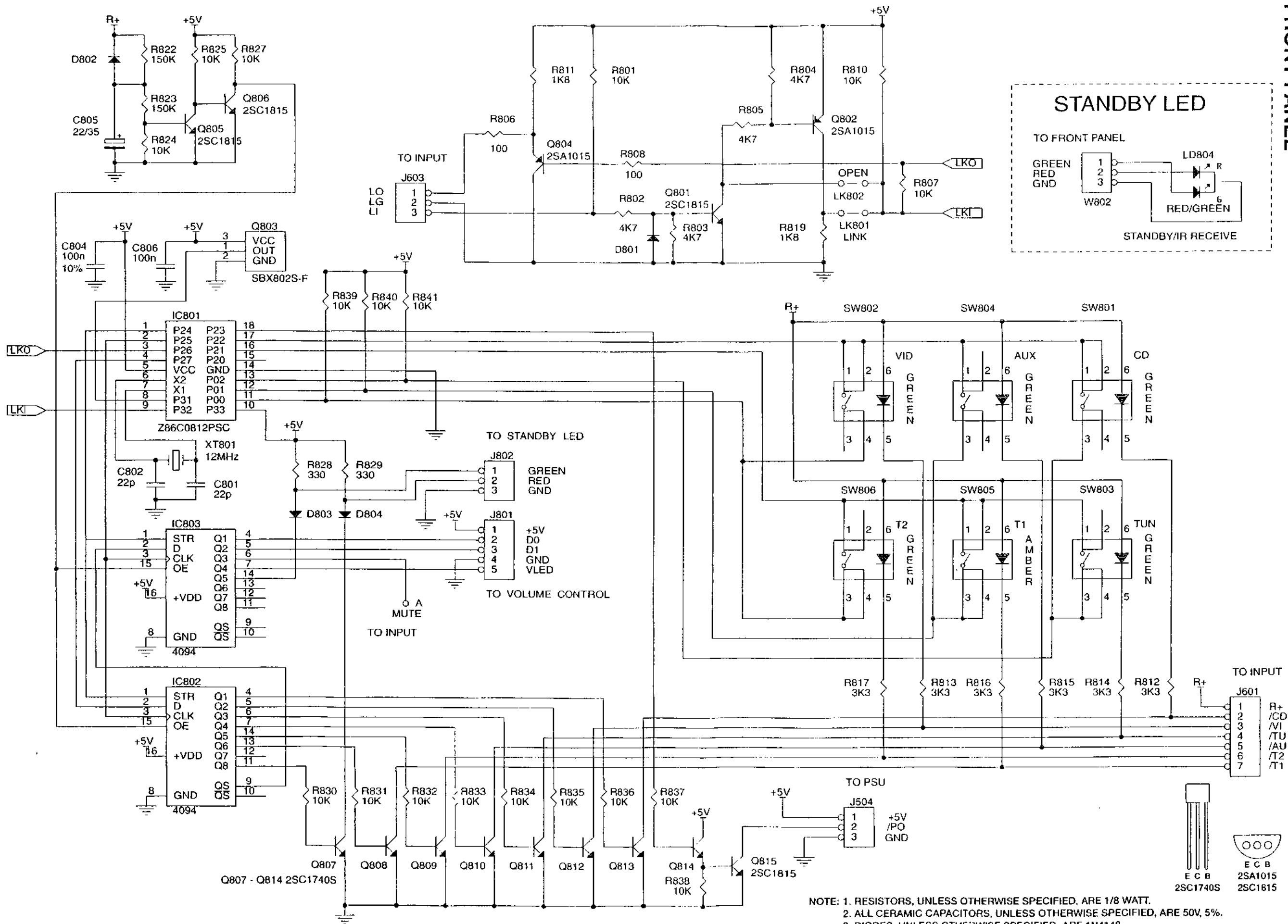

NOTE: 1. RESISTORS, UNLESS OTHERWISE SPECIFIED, ARE 1/8 WATT.
 2. ALL CERAMIC CAPACITORS, UNLESS OTHERWISE SPECIFIED, ARE 50V, 5%.
 3. DIODES, UNLESS OTHERWISE SPECIFIED, ARE 1N4148.

IC BLOCK DIAGRAM

TONE BOARD, PSU & MAIN BOARD
IC761: NE5532, IC201: AD712

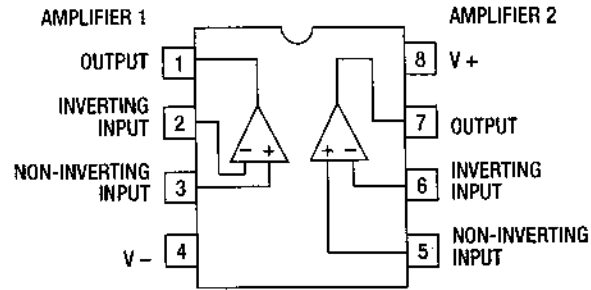

VOLUME BOARD
IC901: LB1642

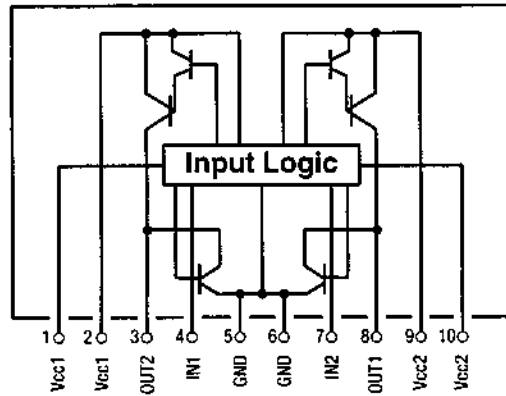

PSU BOARD
IC202: TA7317P

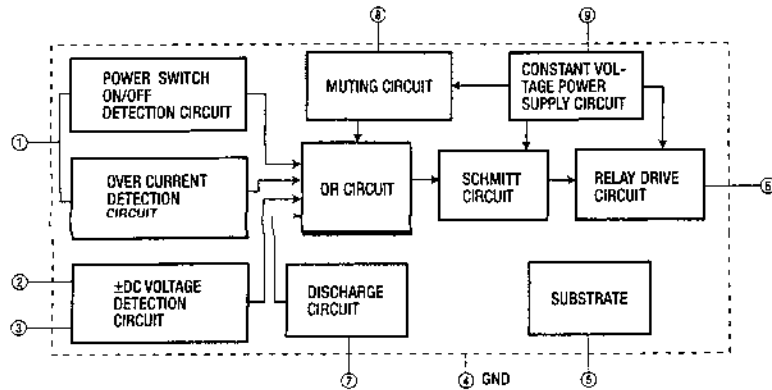

FRONT PANEL BOARD
IC802, IC803: MC14094BCP

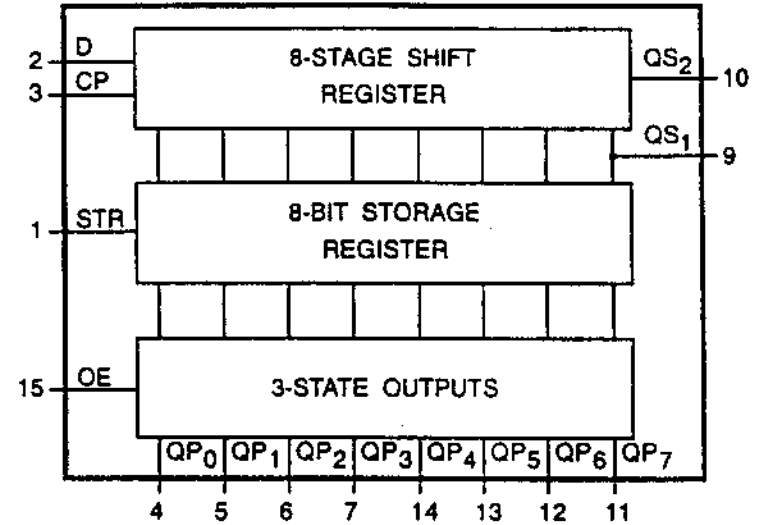

IC801: R2649 NAD 116/317

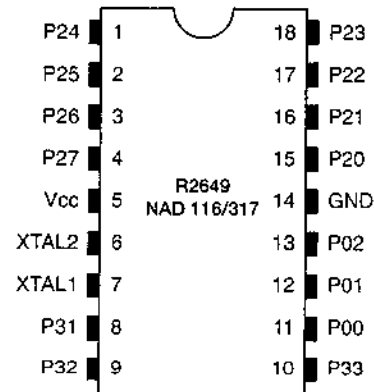

PIN IDENTIFICATION

Z86E/08	STANDARD			
08	MODE			
PIN #	SYMBOL	FUNCTION		DIRECTION
1-4	P24-P27	Port 2, Pins 4, 5, 6, 7		In/Output
5	Vcc	Power Supply		
6	XTAL2	Crystal Osc. Clock		Output
7	XTAL1	Crystal Osc. Clock		Input
8	P31	Port 3, Pin 1		Input
9	P32	Port 3, Pin 2		Input
10	P33	Port 3, Pin 3		Input
11-13	P00-P02	Port 0, Pins 0, 1, 2		In/Output
14	GND	Ground		
15-18	P20-P23	Port 2, Pins 0, 1, 2, 3		In/Output

EXPLODED VIEW PARTS LIST

Item	Part No	Description	Qty
0001	1402-5011-0	FASCIA	1
0002	1402-5020-0	SUBFASCIA	1
0003	1402-3270-1	BASE PLATE	1
0004	1402-3290-2	CHANNEL	1
0005*AH	1402-5032-0	REAR PANEL	1
0005*B,C	1402-5082-0	REAR PANEL	1
0006	1402-3280-0	TOP COVER	1
0007	1402-3300-0	ACCESS COVER	2
0008	4132-1661-0	THERMAL SWITCH MOUNTING CLIP	2
0009	4132-1671-0	TRANSISTOR CLAMP	4
0010	5400-0841-0	MAIN HEATSINK	2
0011	2437-640B-0	POWER BUTTON DIA 11.5 GREEN	1
0012	1402-3460-0	35MM KNOB SKIN	1
0013	2437-7706-0	35MM KNOB LENS	1
0014	2437-7601-0	35MM KNOB CORE	1
0015	2437-5701-1	KNOB 18.5MM (BASS,TREBLE,BALANCE)	3
0016	4152-0041-0	POINTER	3
0017	2437-6001-0	LONG BUTTON 8.0MM	1
0018	3714-910B-0	IRS WINDOW LENS	1
0019	4152-1871-0	BEZEL	1
0020	2439-9701-0	SINGLE LENS BUTTON	6
0021	3714-9206-1	BUTTON LENS	6
0022	4152-1871-0	BEZEL CLUSTER	1
0023	4152-1881-0	POWER BEZEL	1
0024	4152-1891-0	LED BEZEL	1
0025	4152-0011-0	LED LENS	4
0027	2907-8070-2000	M8X1.25P HEX HD (WHT.ZN)	1
0028	2836-8075-0	NUT M8X1.25P 6.5T (WHT.ZN)	1
0030	4132-1971-0	FLAT WASHER M8X22X1.5	4
0031	4152-1911-0	CABLE CLAMP	6
0033	4151-9951-1	PCB SUPPORT DSPLS-4 6.4MM HIGH	4
0034	4151-9461-0	STRAIN RELIEF BUSHING	1
0035	4151-9371-1	RUBBER FOOT 14.8MM HIGH	4
0043	4132-4121-0	PHONE JACK CLIP	1
0101*AH	7009-3100-1	AC CORD	1
0101*B	7009-5100-0	AC CORD	1
0101*C	7009-3110-0	AC CORD	1
0102*AH	2103-7701-2	AC OUTLET	1
0103*AH	4151-9941-0	AC OUTLET COVER PLATE	1
0201	2900-4006-3010	M4X0.5PX6MM W/FLAT WASHER	6
0202	2904-3008-3000	SCREW M3X8 (BLK.ZN)	4
0203	2842-3367-0	METAL WASHER ID=3.3 OD=6.7	4
0204	2954-3010-3000	TAPPING 3X10MM B-TITE (BLK.ZN)	2
0205	2954-3008-3000	TAPPING 3X8MM B-TITE (BLK.ZN)	23
0206	2954-3006-0000	TAPPING 3X6MM B-TITE (YEL.ZN)	21
0208	2904-3006-0000	SCREW M3X6 (YEL.ZN)	4
0212	2950-3508-3000	TAPPING 3.5X8MM B-TITE (BLK.ZN)	10
0213	2954-3510-3000	TAPPING 3.5X10MM B-TITE (BLK.ZN)	19
0222	2954-2606-0000	TAPPING 2.6X6MM B-TITE (YEL.ZN)	10
0224	2954-3008-0000	TAPPING 3X8MM B-TITE (YEL.ZN)	10

ELECTRICAL PARTS LIST

Item	Part No	Description	Qty
0226	2908-4012-3400	HEXAGON SOCKET HEAD 4X12MM	4
0230	2904-3008-3000	SCREW M3X8 (BLK.ZN)	2
0231	2836-3005-0	M3X0.5P HEX CAP NUT	2
0302	1660-0710-0	GLASS-FIBRE SLEEVE TUBE ID=10	1
0311	1660-0630-0	SHRINKABLE TUBE ID=14MM	1
0400*AH	N21038104-0	SPK.TERMINAL W/O PLUG	1
0400*B,C	2113-1133-0	SPK. TERMINAL W/PLUG	1
FH501-FH502	4131-9131-0	FUSE HOLDER 6.5MM PITCH RECT	4
HS1-2,HS603	5400-0851-0	HEATSINK	3
HS3	5400-0821-1	HEATSINK	1
HS4-8	5400-0831-0	HEATSINK	5
JK201,JK604	2103-7902-0	2P RCA JACK YKC21-3539	2
JK601	2113-1101-0	8P RCA JACK R/W AUHSP-248V	1
JK602-3	2113-0104-0	4P RCA R/W AU 14X14 PITCH	2
JK605	2113-1121-0	2P RCA JACK Y/Y AU HSP-242V-22	1
JK801	2113-1081-1	PHONE-JACK 6.5MM GOLD	1
P701	4750-3646-0	VR-TRE 2X10KC W/WASHER & NUT	1
P702	4750-3676-0	VR-BASS 2X50KC W/WASHER & NUT	1
P801	4750-4470-0	MOTOR POT20KAX2 VOL	1
P902	4750-3656-0	VR-BAL 1X10KW W/WASHER & NUT	1
SW201	5200-3161-0-01	4PDT SLIDE SW.SK-42F28-G6TS	1
SW202	5200-3171-0-01	DPDT SLIDE SW.SK-22F28-G9TS	1
SW501	5200-3181-0-01	POWER SWITCH SDDFA3066A	1
SW701	5200-3121-0-01	DPDT ALPS SPUN W/O FRAME	1
T501	1806-2142-1	POWER TRANSFORMER W/HUMSHIELD	1
T502*AH	1806-2147-0	TRANS AC 120V DC9V 350MA EI-35	1
T502*B,C	1806-2148-0	TRANS AC 230V DC9V 350MA EI-35	1

NOTE: - The components identified by Δ mark are critical for risk of fire and electrical shock. Replace only with part number specified.
 - <AH > : USA, Canadian model only.
 - : UK model only.
 - <C > : European model only.

Reference No	Part Number	Description
PSU MAIN ASSEMBLY		
PC BOARD		
*AH	MI-21850A-01-S	PSU MAIN ASSEMBLY
*B,C	MI-21850A-02-S	PSU MAIN ASSEMBLY
CAPACITORS		
C101-C102	N158R101J-5-IQ	CP 250V 100pF 5%
C103-C104	153I-105K-9-NL	CM 63V 1 μ F 10%
C105-C106	153I-474K-9-NL	CM 63V 0.47 μ F 10%
C202-C205	N89100057-0	CE 63V 4700 μ F 20%
C206-C207	N157I227M-5-S9	CE 63V 220 μ F 20%
C208-C209	153R-103M-9-NL	CM 250V 0.01 μ F 20%
C210-C213	N89100056-0	CE 160V 220 μ F 20%
C214-C215	157H-476M-5-S5	CE 100V 47 μ F 20%
C216-C217	15CG-220J-7-4J	CC 50V 22pF 5% NPO
C218	157I-106M-5-IU	CE 63V 10 μ F 20%
C219	157I-226M-5-IU	CE 63V 22 μ F 20%
C220-C221	157I-107M-5-SX	CE 63V 100 μ F 20%
C222-C223	N157H474M-5-IU	CE 100V 0.47 μ F 20%
C224	157C-226M-5-IU	CE 10V 22 μ F 20%
C225	153H-104M-9-NL	CM 100V 0.1 μ F 20%
C226	N157H105M-5-IU	CE 100V 1 μ F 20%
C227-C228	157C-107M-5-IU	CE 10V 100 μ F 20%
C229-C230	157E-106M-5-IU	CE 25V 10 μ F 20%
C231-C232	157C-476M-5-IU	CE 10V 47 μ F 20%
C501	N89100049-0	CAP 400V 4700pF DE7150F472MVA1KC
C502	157D-108M-5-S9	CE 16V 1000 μ F 20%
C503-C504	153H-104M-9-NL	CM 100V 0.1 μ F 20%
C505	157F-106M-5-IU	CE 50V 10 μ F 20%
C901-C902	N89100057-0	CE 63V 4700 μ F 20%
DIODES		
D101-D104	4804-1480-2	DIODE 1N4148
D201	N48400610-0	BRIDGE DIODE GBU8D
D202-D207	4804-0030-2	DIODE 1N4003
D208-D209	4837-27V0-2	ZENER DIODE 1/2W 27V(26.2-27.6)
D210-D211	4804-1480-2	DIODE 1N4148
D213-D214	4840-0510-0	ZENER DIODE 1/2W 15V HZ 15-3
D215-D216	4840-0620-0	ZENER DIODE 1/2W 24V (23.6-24.7)
D501-D504	4804-0030-2	DIODE 1N4003
D505	4804-1480-2	DIODE 1N4148
FUSES		
F501*AH	N51007030-1A	FUSE 7A 125V TIME LAG LBC UL/CSA
F501*B,C	N51002530-1B	FUSE 2.5A 250V TIME LAG LBC SEMKO/VDE
F502*AH	5120-0036-0	FUSE 100mA 250V MEDIUM TIME LAG LBC UL/CSA
F502*B,C	5120-0035-0	FUSE 100mA 250V TIME LAG LBC SEMKO/VDE

Reference No	Part Number	Description
Q309-Q310	N485240GR-5	TR 2SC2240GR
Q311-Q312	N48600650-5	TR 2SA970GR
Q313-Q314	N48600680-5	TR 2SA1370 (E)
Q315-Q316	N48600720-5	TR 2SC3467 (E)
Q317-Q318	N48600790-5	TR 2SC3423 (Y)
Q319-Q320	N48600740-5	TR 2SD600K (E,F)
Q321-Q322	N48600720-5	TR 2SC3467 (E)
Q323-Q324	N48600680-5	TR 2SA1370 (E)
Q325-Q326	4860-1060-5	TR 2SC4793 HFE 100-320
Q327-Q328	4860-1050-5	TR 2SA1837 HFE 100-320
Q329-Q330	N48600730-5	TR 2SC3519 (O,P,Y)
Q331-Q332	N48600690-5	TR 2SA1386 (O,P,Y)
Q333-Q334	N48600730-5	TR 2SC3519 (O,P,Y)
Q335-Q336	N48600690-5	TR 2SA1386 (O,P,Y)
Q337-Q338	N48600720-5	TR 2SC3467 (E)
Q339-Q340	N48600650-5	TR 2SA970GR
RESISTORS		
R301-R302	4715-101A-2	RMF 100 Ohm 1/4W 1%
R303-R304	4715-124A-2	RMF 120k Ohm 1/4W 1%
R305-R306	4715-473A-2	RMF 47k Ohm 1/4W 1%
R307-R308	4715-101J-2-F	RFU 100 Ohm 1/4W 5%
R309-R312	4715-201A-2	RMF 200 Ohm 1/4W 1%
R313-R314	4715-473A-2	RMF 47k Ohm 1/4W 1%
R315-R316	4715-101J-2-F	RFU 100 Ohm 1/4W 5%
R317-R318	4715-124A-2	RMF 120k Ohm 1/4W 1%
R319-R322	4715-270A-2	RMF 27 Ohm 1/4W 1%
R323-R324	4715-102J-2-F	RFU 1k Ohm 1/4W 5%
R327-R328	4715-102J-2-F	RFU 1k Ohm 1/4W 5%
R331-R332	4715-390J-2-F	RFU 39 Ohm 1/4W 5%
R333-R334	4715-121J-2-F	RFU 120 Ohm 1/4W 5%
R335-R336	N4715330J-2-P	RFP 33 Ohm 1/4W 5%
R341-R346	4715-121J-2-F	RFU 120 Ohm 1/4W 5%
R347-R348	N4715681J-2-P	RFP 680 Ohm 1/4W 5%
R349-R350	4717-121J-2-F	RFU 120 Ohm 1/2W 5%
R351-R354	4717-4R7J-2-F	RFU 4.7 Ohm 1/2W 5%
R355-R358	471A-022K-5-N	RCE 0.22 Ohm 3W 10%
R359-R362	4717-4R7J-2-F	RFU 4.7 Ohm 1/2W 5%
R363-R366	471A-022K-5-N	RCE 0.22 Ohm 3W 10%
R367-R368	4719-100J-1-P	RFP 10 Ohm 2W 5%
R385-R386	N4717392A-2	RMF 3.9k Ohm 1/2W 1%
R387-R388	N4718152A-1	RMF 1.5k Ohm 1W 1%
R390	N4715121A-2	RMF 120 Ohm 1/4W 1%
THERMAL BREAKERS		
TH101-TH102	N89100055-0	THERMAL BREAKER 90C
VARIABLE RESISTORS		
VR301-VR302	N47564716-3-06	SVR 470 H3 7X7.6

Reference No	Part Number	Description
INPUT ASSEMBLY		
PC BOARD		
	MI-21860B-01-S	INPUT ASSEMBLY
CAPACITORS		
C651-C654	153I-104K-9-NL	CM 63V 0.1µF 10%
C655-C656	157F-106M-5-IU	CE 50V 10µF 20%
DIODES		
D601-D606	4804-1480-2	DIODE 1N4148
D651	4840-0620-0	ZENER DIODE 1/2W 24V (23.6-24.7)
D656	4804-1480-2	DIODE 1N4148
D657-D658	4840-1260-0	ZENER DIODE 1.3W 16V
ICs		
IC651	3130-4810-0	IC LM78L24 REGULATOR
IC652	3130-4820-0	IC LM79L24 REGULATOR
TRANSISTORS		
Q651	N485D1390-5	TR BD139-10 HFE 63-160
Q655	N485240GR-5	TR 2SC2240GR
RESISTORS		
R651	4717-680J-2-F	RFU 68 Ohm 1/2W 5%
RELAYS		
RL601-RL606	4500-0210-0	RELAY GY-24W-K (TAKAMISAWA)
RL609	4500-0210-0	RELAY GY-24W-K (TAKAMISAWA)
LED ASSEMBLY		
PC BOARD		
	MI-21860C-01-S	LED ASSEMBLY
LEDS		
LD801-LD802	N37003513-Y	LED AMBER (L-424YDT)
LD803	3700-2522-R	LED RED
STANDBY LED ASSEMBLY		
PC BOARD		
	MI-21860D-01-S	STANDBY LED ASSEMBLY
LED		
LD804	N37003517-RG	LED RED/GREEN (L-469HGW)
POWER SWITCH ASSEMBLY		
PC BOARD		
	MI-21850F-01-S	POWER SWITCH PCB ASSEMBLY
CAPACITOR		
C502	N89100049-0	CAP 400V 4700pF DE7150F472MVA1KC

NOTE : - The components identified by Δ mark are critical for risk of fire and electrical shock.
 Replace only with part number specified.
 - <'AH' > : USA, Canadian model only.
 - <'B' > : UK model only.
 - <'C' > : European model only.
 - Capacitors : CP-Polystyrene, CM-Mylar, CE-Electrolytic, CC-Ceramic.
 - Resistors : RMF-Metal Film, RFU-Fusible, RFP-Flame Proof, RCE-Ceramic Case.

PACKING DIAGRAM

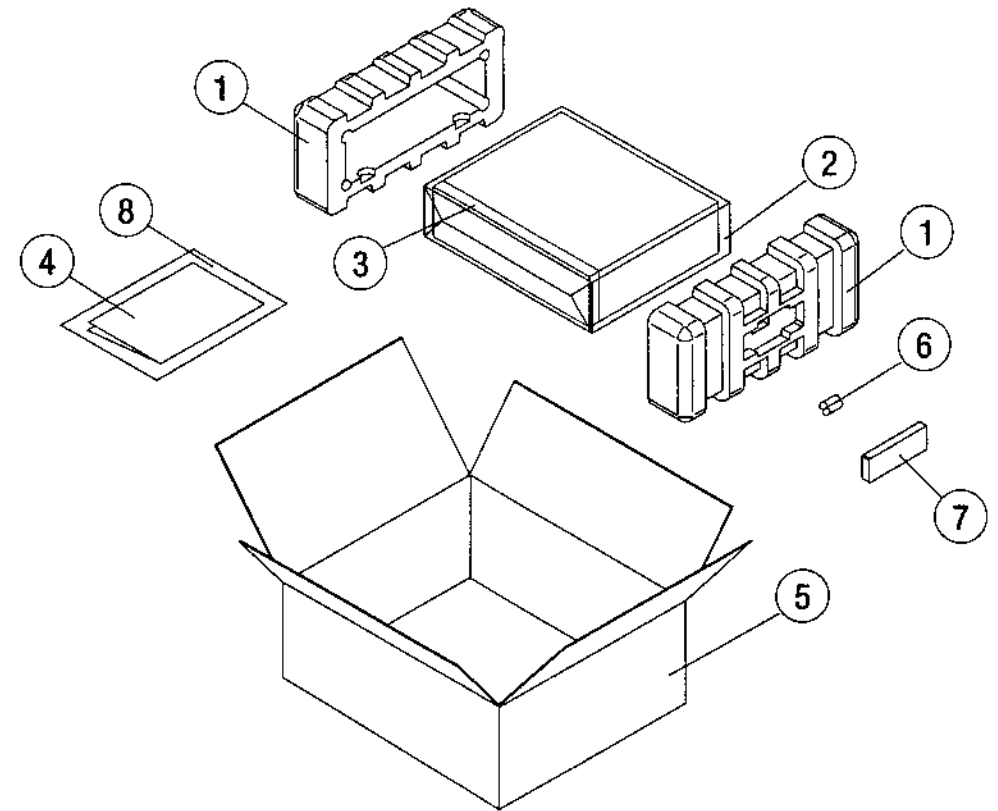

PACKING LIST

Item	Part No.	Description	Qty
1	1490-2093-1	POLYFOAM END CAP	2
2	N14971072-3	UNIT POLYBAG	1
3	N14971252-0	FASCIA COVER	1
4	4301-3669-0	INSTRUCTION MANUAL	1
5	1476-5201-0	CARTON BOX	1
6	4060-0580-0	BATTERIES	2
7	8900-1070-0	REMOTE CONTROL	1
8	N14971062-0	MANUAL POLYBAG	1

Reference No	Part Number	Description
ICs		
IC201	N31303830-0	IC AD712 (JN) ANALOG DEVICES
IC202	N31303550-0	IC TA7317P
IC501	3130-2020-3	IC 7805 REGULATOR
TRANSISTORS		
Q101-Q102	N48600770-5	TR 2SC2878 (A,B)
Q201	N48600740-5	TR 2SD600K (E,F)
Q202	N4851815Y-5	TR 2SC1815-Y HFE 120-240
Q203	N48600650-5	TR 2SA970GR
Q204	N48600870-5	TR 2SB631K (E,F)
Q205-Q206	N4851815Y-5	TR 2SC1815-Y HFE 120-240
Q207	N48600650-5	TR 2SA970GR
Q208	N485240GR-5	TR 2SC2240GR
RESISTORS		
R101-R102	4715-124A-2	RMF 120k Ohm 1/4W 1%
R103-R104	4715-152A-2	RMF 1.5k Ohm 1/4W 1%
R105-R106	4715-124A-2	RMF 120k Ohm 1/4W 1%
R107-R108	4715-152A-2	RMF 1.5k Ohm 1/4W 1%
R109-R110	N4715225A-2	RMF 2.2M Ohm 1/4W 1%
R201-R202	△ N4718100J-L-F	RFU 10 Ohm 1W 5%
R203-R205	△ 4715-101J-2-F	RFU 100 Ohm 1/4W 5%
R208	△ 4715-101J-2-F	RFU 100 Ohm 1/4W 5%
R212	4715-223A-2	RMF 22k Ohm 1/4W 1%
R217	4715-223A-2	RMF 22k Ohm 1/4W 1%
R229	△ 4717-681J-2-F	RFU 680 Ohm 1/2W 5%
R250	4718-152A-1	RMF 1.5k Ohm 1W 1%
R251	N4717272A-2	RMF 2.7k Ohm 1/2W 1%
R252	△ 4715-101J-2-F	RFU 100 Ohm 1/4W 5%
R501	△ 4715-3R9J-2-F	RFU 3.9 Ohm 1/4W 5%
RELAYS		
RL201	N45000130-0	RELAY DEC DH48D2-0
RL501	△ 4500-0230-0	RELAY VS-5MB TV810A
TONE ASSEMBLY PC BOARD		
	MI-21850B-01-S	TONE ASSEMBLY
CAPACITORS		
C701-C702	153I-474J-9-NO	CM 63V 0.47μF 5%
C709-C710	157F-476M-5-IU	CE 50V 47μF 20%
C711,C713	153I-104K-9-NL	CM 63V 0.1μF 10%
C715-C716	157F-107M-5-OW	CE 50V 100μF 20%
C717-C718	157F-476M-5-IU	CE 50V 47μF 20%
C719-C720	153I-183K-9-NL	CM 63V 0.018μF 10%
C721-C722	153I-104K-9-NL	CM 63V 0.1μF 10%
C723-C724	153I-823K-9-NL	CM 63V 0.082μF 10%
C725-C726	153I-474J-9-NO	CM 63V 0.47μF 5%
C751-C754	153I-104K-9-NL	CM 63V 0.1μF 10%
C755-C756	157F-106M-5-IU	CE 50V 10μF 20%
C761-C762	157F-105M-5-IU	CE 50V 1μF 20%
C769-C770	157F-107M-5-OW	CE 50V 100μF 20%
C771-C772	153I-222K-9-NL	CM 63V 2200pF 10%

Reference No	Part Number	Description
DIODES		
D701-D706	4804-1480-2	DIODE 1N4148
ICs		
IC751	3130-4830-0	IC LM78L18 REGULATOR
IC752	3130-4840-0	IC LM79L18 REGULATOR
IC761	3130-2430-0	IC NE5532 OP AMP
TRANSISTORS		
Q701-Q702	N48600670-5	TR 2SA1316BL
Q703-Q706	N4851815Y-5	TR 2SC1815-Y HFE 120-240
Q707-Q708	N48600660-5	TR 2SA1015GR
RESISTORS		
R701-R702	4715-224C-2	RMF 220k Ohm 1/4W 2%
R703-R704	4715-391C-2	RMF 390 Ohm 1/4W 2%
R705-R706	4715-153C-2	RMF 15k Ohm 1/4W 2%
R717-R718	4715-392C-2	RMF 3.9k Ohm 1/4W 2%
R719-R720	4715-681C-2	RMF 680 Ohm 1/4W 2%
R721-R722	4715-272C-2	RMF 2.7k Ohm 1/4W 2%
R723-R724	4715-102C-2	RMF 1k Ohm 1/4W 2%
R725-R726	4715-181C-2	RMF 180 Ohm 1/4W 2%
R727-R728	4715-392C-2	RMF 3.9k Ohm 1/4W 2%
R729-R729	4715-681C-2	RMF 680 Ohm 1/4W 2%
R731-R732	4715-221C-2	RMF 220 Ohm 1/4W 2%
R763-R764	4715-682C-2	RMF 6.8k Ohm 1/4W 2%
R765-R766	4715-333C-2	RMF 33k Ohm 1/4W 2%
R767-R768	4715-102C-2	RMF 1k Ohm 1/4W 2%
R769-R770	4715-472C-2	RMF 4.7k Ohm 1/4W 2%
FRONT PANEL ASSEMBLY PC BOARD		
	MI-21850C-01-S	FRONT PANEL ASSEMBLY
CAPACITORS		
C805	157Q-226M-5-OW	CE 35V 22µF 20%
C806	153H-104M-9-NL	CM 100V 0.1µF 20%
DIODES		
D801-D804	4804-1480-2	DIODE 1N4148
ICs		
IC801	3130-4740-1	Z86E0812PSCSR2649 MASKED (NAD116/317)
IC802-IC803	N31303600-0	MC14094BCP 8-BIT SIPO SR 3S
TRANSISTORS		
Q801	4860-0700-5	TR 2SC1815GR
Q802	N48600660-5	TR 2SA1015GR
Q803	481X-8025-3	IR SENSOR SBX8025-F
Q804	N48600660-5	TR 2SA1015GR
Q805-Q806	4860-0700-5	TR 2SC1815GR
Q807-Q814	4860-1590-5	TR 2SC1740S HFE 180-390
Q815	4860-0700-5	TR 2SC1815GR
SWITCHES		
SW801-SW804	N52003201-0-01	TACT LED GREEN SKWQFG ALPS

Reference No	Part Number	Description
SW805 SW806	N52003231-0-01 N52003201-0-01	TACT LED AMBER SKHQFH ALPS TACT LED GREEN SKWQFG ALPS
RESONATOR		
XT801	2703-0190-0	CR RESONATOR CSA 12MHZ
VOLUME ASSEMBLY PC BOARD		
	MI-21850D-01-S	VOLUME ASSEMBLY
CAPACITOR		
C901	157E-107M-5-KW	CE 25V 100µF 20%
IC		
IC901	N31303410-0	IC LB1642 SANYO MOTOR DRIVER
SPEAKER ASSEMBLY PC BOARD		
*AH *B,C	MI-21850E-01-S MI-21850E-02-S	SPEAKER ASSEMBLY SPEAKER ASSEMBLY
COILS		
L401-L402	N18040490-0	SPRING COIL 1µH 1/9/16.5
RESISTORS		
R401-R402	N47183R3J-2-P	RFP 3.3 Ohm 1W 5%
PAL/PAR ASSEMBLY PC BOARD		
	MI-21860A-01-S	PAL/PAR ASSEMBLY
CAPACITORS		
C301-C302	N158F391J-5-IQ	CP 50V 390pF 5%
C303-C304	153H-104M-9-NL	CM 100V 0.1µF 20%
C305-C306	157I-106M-5-IU	CE 63V 10µF 20%
C307-C308	153H-104M-9-NL	CM 100V 0.1µF 20%
C309-C310	157I-106M-5-IU	CE 63V 10µF 20%
C311-C314	N158F391J-5-IQ	CP 50V 390pF 5%
C315-C318	N158K221J-5-IQ	CP 150V 220pF 5%
C319-C320	153H-104M-9-NL	CM 100V 0.1µF 20%
C321-C324	N158R101J-5-IQ	CP 250V 100pF 5%
C325-C326	153H-104M-9-NL	CM 100V 0.1µF 20%
C327-C328	153H-473K-9-SW	CM 100V 0.047µF 10%
C329-C330	157C-476M-5-IU	CE 10V 47µF 20%
C331-C336	157I-106M-5-IU	CE 63V 10µF 20%
DIODES		
D302-D304	4840-0590-0	DIODE 1S5143
D305-D308	N48054J20-L	DIODE 1N5402
D309-D310	4840-0590-0	DIODE 1S5143
TRANSISTORS		
Q301-Q302	N48600650-5	TR 2SA970GR
Q303-Q306	N485240GR-5	TR 2SC2240GR
Q307-Q308	N48600650-5	TR 2SA970GR