

SERVICE MANUAL

NAD

SERVICE SAFETY PRECAUTIONS (UL)

1. Use exact replacement parts for critical locations marked "⚠"
2. Return lead dress to original position and re-install protective covers.
3. Before returning to customer, test for shock hazard; use either method A or B:
 - A. Leakage test "cold":
 1. Unplug the AC cord; turn power switch ON.
 2. Connect one lead of High Voltage Insulation Tester to both prongs of the AC plug.
 3. Touch other lead to all exposed metal parts.
 4. Impedance measurement must be 0.3-5.0 Megohms.
 - B. Leakage test, "live":
 1. Plug unit directly into the AC outlet: do not use isolation transformer.
 2. Connect one lead of the Leakage Current Tester to earth ground.
 3. Touch other lead to all exposed metal parts.
 4. Leakage measurement must be less than 0.5 milliamps.

312

STEREO INTEGRATED
AMPLIFIER

312

STEREO
INTEGRATED
AMPLIFIER

SERVICE SAFETY PRECAUTIONS

1. Replacing the fuses

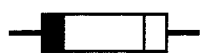

This symbol located near the fuse indicates that the fuse used is fast operating type. For continued protection against fire hazard, replace with same type fuse. For fuse rating refer to the marking adjacent to the symbol.

<u>Reference No</u>	<u>Part Number</u>	<u>Description</u>
F503-F504*AH	5120-0019-0	Fuse 4A 125V Slow Blow LBC (UL/CSA)
F503-F504*B,B1,C	5120-0017-0	Fuse 4A 250V Time Lag HBC (SEMKO/VDE)
F505-F506*AH	5120-0026-0	Fuse 315mA 250V Time Lag LBC (UL/CSA)
F505-F506*B,B1,C	5120-0027-0	Fuse 315mA 250V Time Lag LBC (SEMKO/VDE)

NOTE :

- <*AH > : USA, CANADIAN MODEL ONLY.
- <*B > : UK MODEL ONLY.
- <*B1 > : AUSTRALIAN MODEL ONLY.
- <*C > : EUROPEAN MODEL ONLY.

2. Safety-check out

(Only U.S.A. model)

After correcting the original service problem perform the following safety check before releasing the set to the customer.

Connect the insulating-resistance tester between the plug of power supply cord and the screw on the back panel.

Specifications : 3.3 Mohm \pm 10% at 500V.

CONTENTS

DESCRIPTION	PAGE
SPECIFICATIONS	4-5
REAR PANEL / FRONT PANEL VIEW.....	6
WIRING DIAGRAM	7-8
DISASSEMBLY INSTRUCTIONS	9
ALIGNMENT PROCEDURE	10
PCB LAYOUT	11
SCHEMATIC DIAGRAM	12-14
EXPLODED VIEW	15
EXPLODED VIEW PARTS LIST	16-17
ELECTRICAL PARTS LIST	18-20
PACKING DIAGRAM / PACKING LIST.....	21

SPECIFICATIONS

POWER AMPLIFIER SECTION

CONTINUOUS AVERAGE POWER OUTPUT INTO 8 OHMS (Min. power per channel, 20 Hz - 20 kHz, both channels driven, with no more than rated distortion)		30 W (14.8 dBW)
Rated Distortion THD (20 Hz - 20 kHz)		0.03%
Clipping power (Maximum continuous power per channel).		40 W
IHF dynamic headroom at 8 ohms		+2.2 dB
IHF dynamic power (Maximum short term power per channel)		
	8 ohms:	50 W (17 dBW)
	4 ohms:	60 W (17.8 dBW)
	2 ohms:	75 W (18.7 dBW)
Slew rate		> 20 V / μsec
Damping factor at 50Hz	8 ohms:	> 60
Input Impedance		R = 20 kohms C = 820 pF
Input sensitivity (for rated output into 8 ohms)		1 V
Voltage gain		x15.5 (23.8 dB)
Frequency response 20 Hz - 20 kHz		\pm0.6 dB - 3 dB at 3 Hz / 70 kHz
Signal / Noise ratio, A-weighted		100 dB ref. 1 W 114.8 dB ref. rated power
THD (Total Harmonic Distortion, 20 Hz - 20 kHz, from 250 mW to rated output)		< 0.03%
SMPTE I.M. (Intermodulation Distortion, 60 Hz + 7 kHz, 4:1, from 250 mW to rated output)		< 0.03%
IHF I.M. (CCIF IM.Distortion, 19 + 20 kHz at rated output)		< 0.03%

PREAMPLIFIER SECTION

PHONO INPUT

Input impedance (R and C)	MM: 47 kohms + 200pF
Input sensitivity (ref. rated power, 1 kHz)	MM: 2.7 mV
Input overload at 20 Hz / kHz / 20 kHz	MM: 22 mV / 220 mV / 2.0 V
THD (20 Hz - 20 kHz) and IM dist.	0.03% at 20 mV input
RIAA accuracy	± 0.5 dB
Signal / Noise ratio (A-weighted with cartridge connected)	MM: 77 dB ref. 5 mV

LINE LEVEL INPUTS

(CD, Video, Auxiliary, Tuner, Tape1, Tape2)

Input impedance (R and C)	20 kohms + 500 pF
Input sensitivity (ref. rated power)	165 mV
Maximum input signal	12V
Signal/ Noise ratio, A-weighted	88 dB ref. 1 W 102.8 dB ref. rated power
Frequency response, 20 Hz - 20 kHz	
Tone Defeat On	±0.3 dB
Tone Defeat Off	±0.6 dB

Infrasonic filter

-3 dB at 10Hz

LINE LEVEL OUTPUTS

THD (20 Hz - 20 kHz)	12 dB /octave 0.02%
Preamp output impedance	220 ohms
Tape output impedance	Source Z + 2 kohms
Headphones output impedance	220 ohms
Maximum output level	> 12 V > 10 V > 10 V into 600 ohms > 500 mV into 8 ohms

CONTROLS

Treble	± 7 dB at 10 kHz
Bass	± 10 dB at 50 Hz

DIMENSIONS AND WEIGHTS

Net Weight	6.9 kg (15.2 lb)
Shipping Weight	8 kg (17.6 lb)
Dimensions (WxHxD)	435mm x 109mm x 300mm

REAR PANEL / FRONT PANEL VIEW

FRONT PANEL

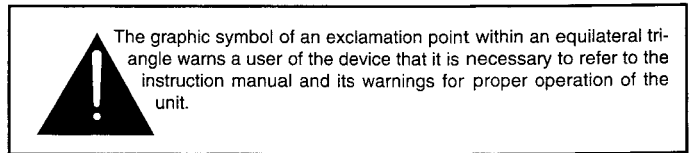
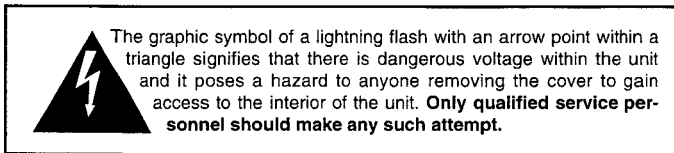
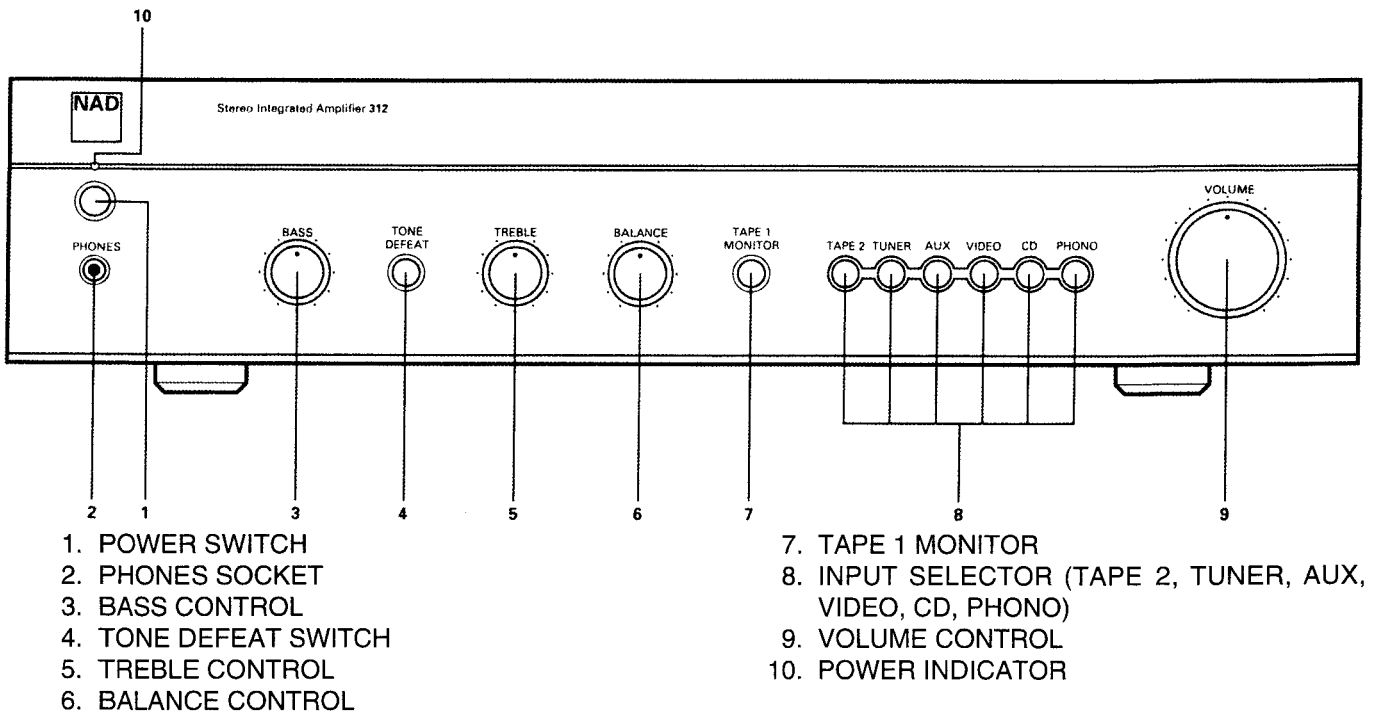

REAR PANEL CONNECTIONS

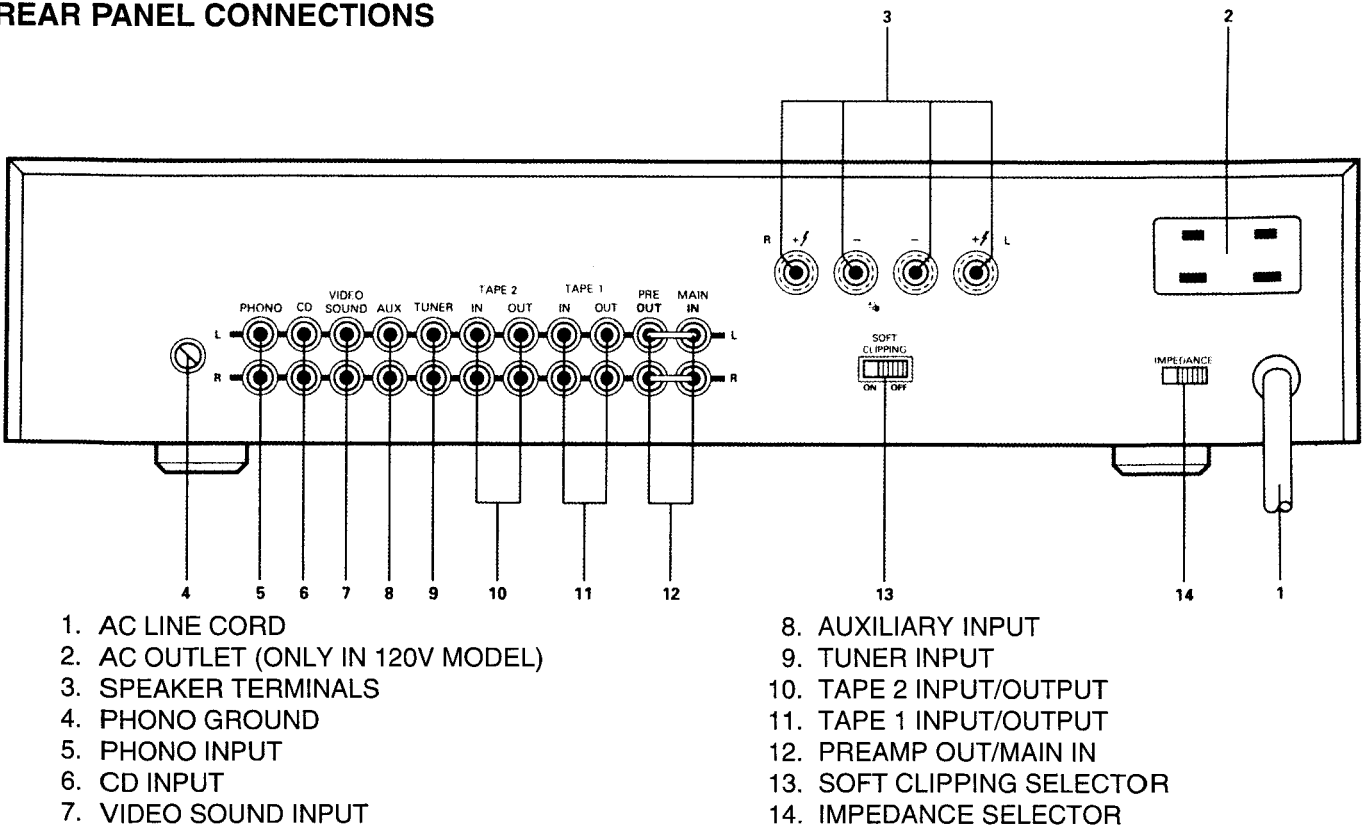

WIRING DIAGRAM

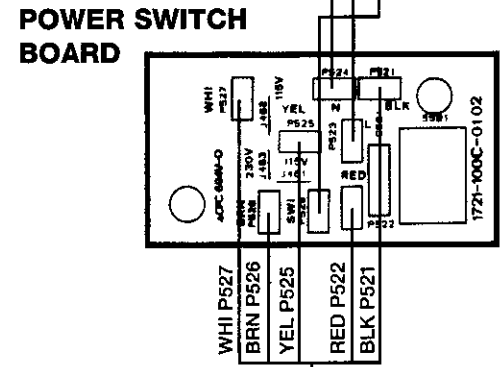
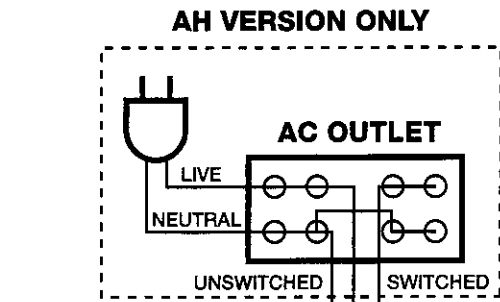

TO TRANSFORMER
PRIMARY

TO TRANSFORMER
SECONDARY

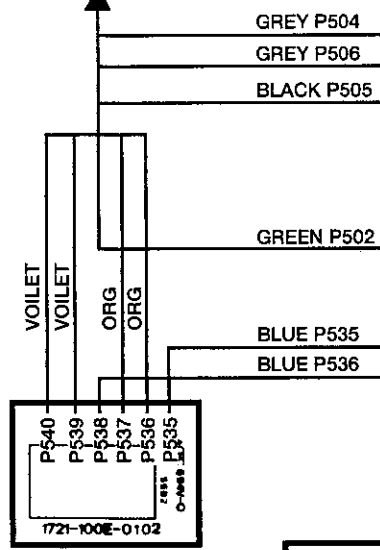

**SPEAKER
TERMINAL
BOARD**

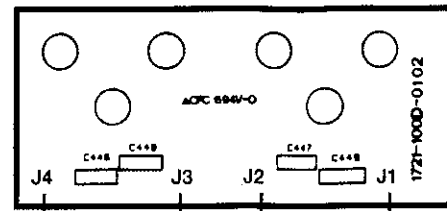

**MOUNTED TO
SUBFASCIA**

**PHONE JACK
BOARD**

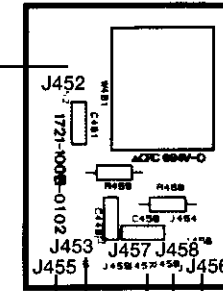

**MOUNTED TO
REAR PANEL**



MAIN BOARD

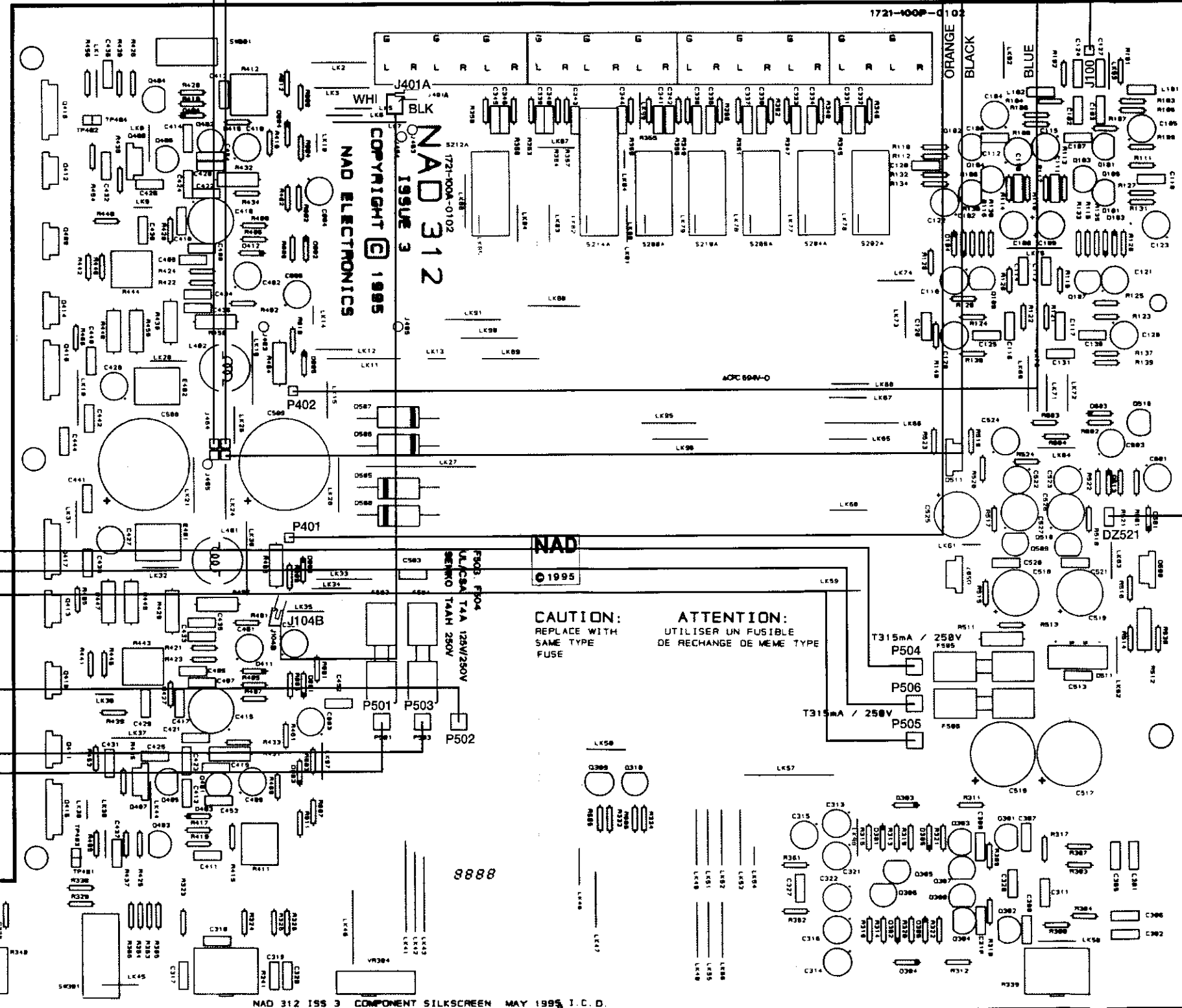

NAD 312 ISS 3 COMPONENT SILKSCREEN MAY 1995 I.C.D.

DISASSEMBLY INSTRUCTIONS

1. Remove machine screws M4.0 x 6.0 (① to ④) from the side panels. Remove tapping screw 3.0 x 8.0 (⑤) from the back panel. Refer to **Figure No. 1**.

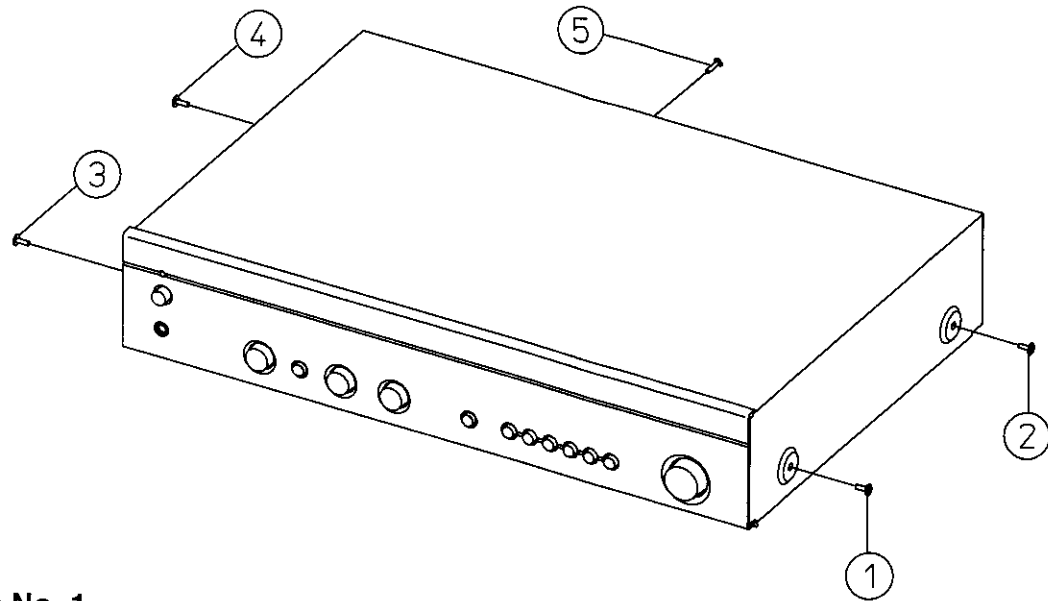

Figure No. 1.

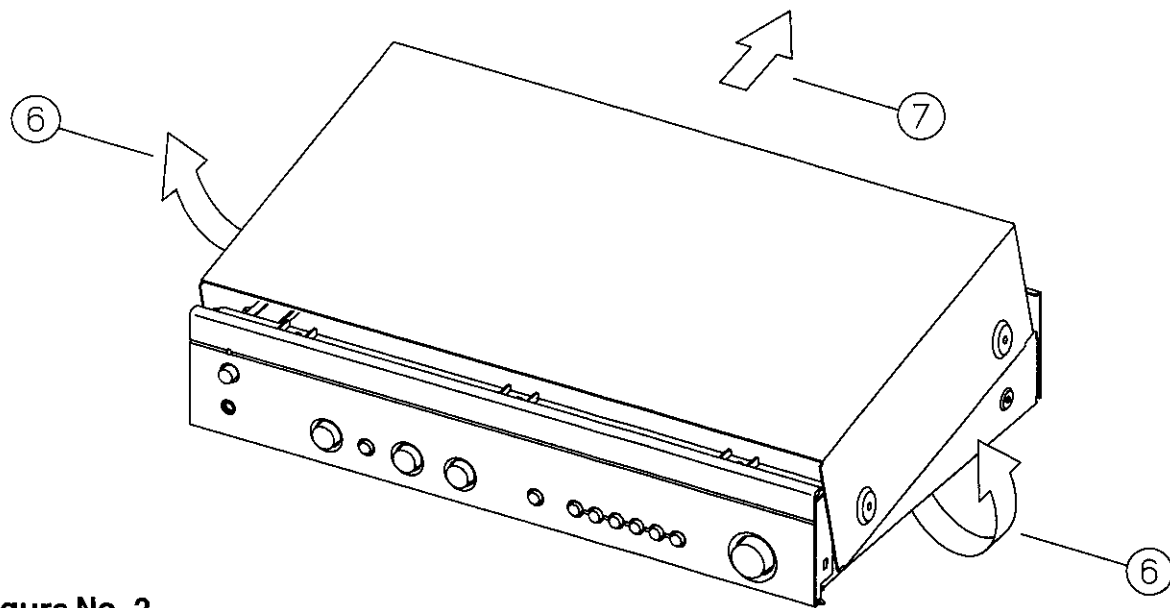

Figure No. 2.

2. Pull both sides of the TOP COVER slightly outwards, tilt approximately 35° and then move in the direction shown in **Figure No. 2**.

ALIGNMENT PROCEDURES

IMPORTANT

Speaker impedance switch should be in 8 ohms position while adjusting center voltage and idling current. Reset switch after adjustment procedure is completed. Remove input signal and load.

A. OUTPUT OFFSET VOLTAGE

1. Connect a DC millivoltmeter to L channel speaker output terminals.
2. Turn unit on and adjust R411 for 0 ± 30 mV reading on meter.
3. Repeat steps 1 and 2 using R channel speaker terminals and adjusting R412.

B. IDLING CURRENT

1. Remove solder link between TP401 and TP403 for left channel and between TP402 and TP404 for right channel, or cut LK1 and LK39.
2. Connect a DC millivoltmeter to TP401 and TP403 (across 1 - ohm resistor at collector of output transistor).
3. Adjust R443 for 25-35 mV reading on meter.
4. Repeat steps 2 and 3 using TP402 and TP404 and adjusting R444.
5. Leave power on for at least 5 minutes.

C. FINAL ADJUSTMENT

1. Repeat output offset voltage and idling current adjustments.
2. WHEN FINISHED, REPLACE SOLDER LINK BETWEEN TP401 AND TP403, AND BETWEEN TP402 AND TP404 OR RECONNECT LK1 AND LK39.

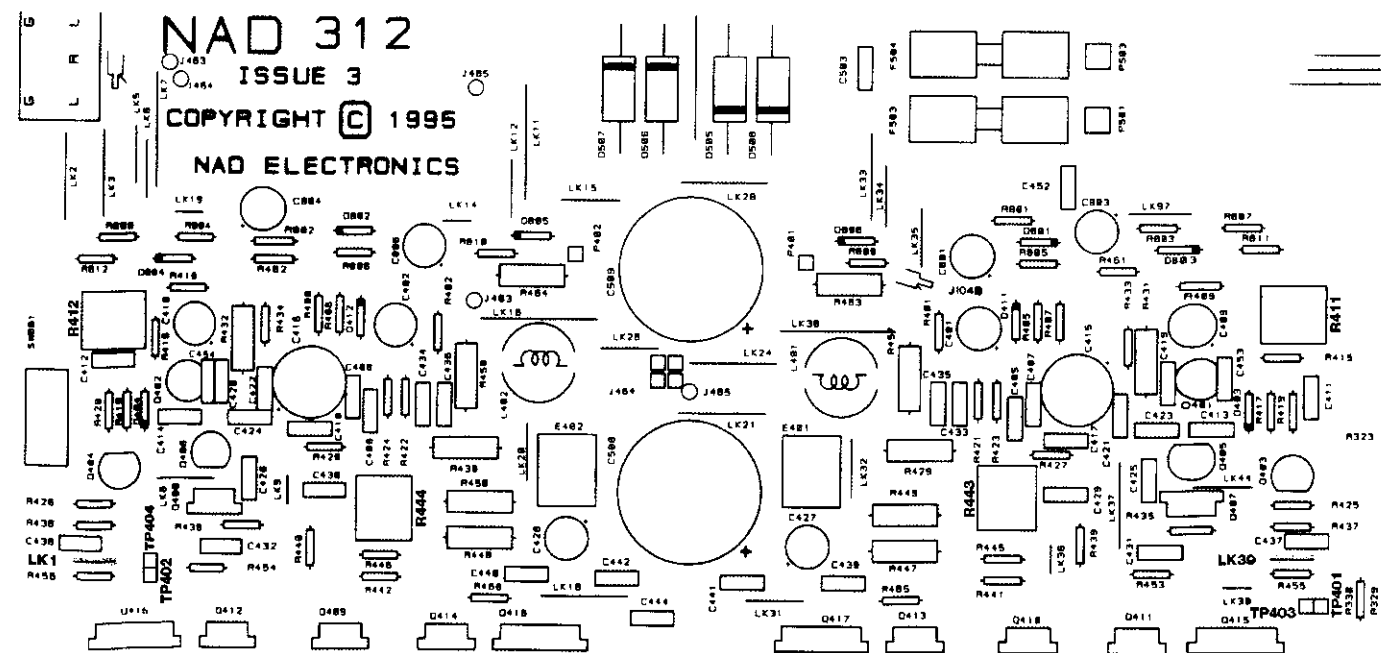

PCB LAYOUT

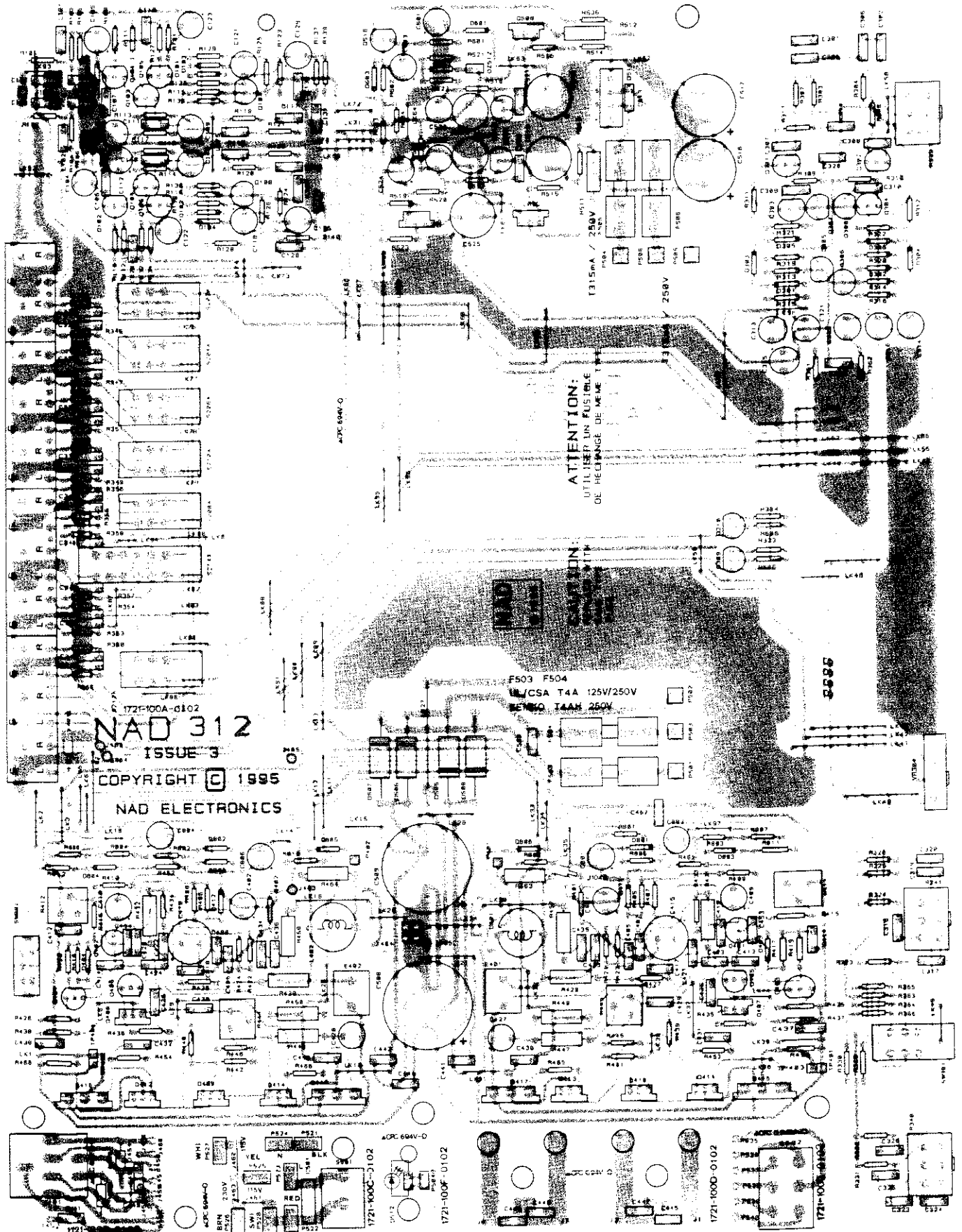

SCHEMATIC DIAGRAM

PREAMP

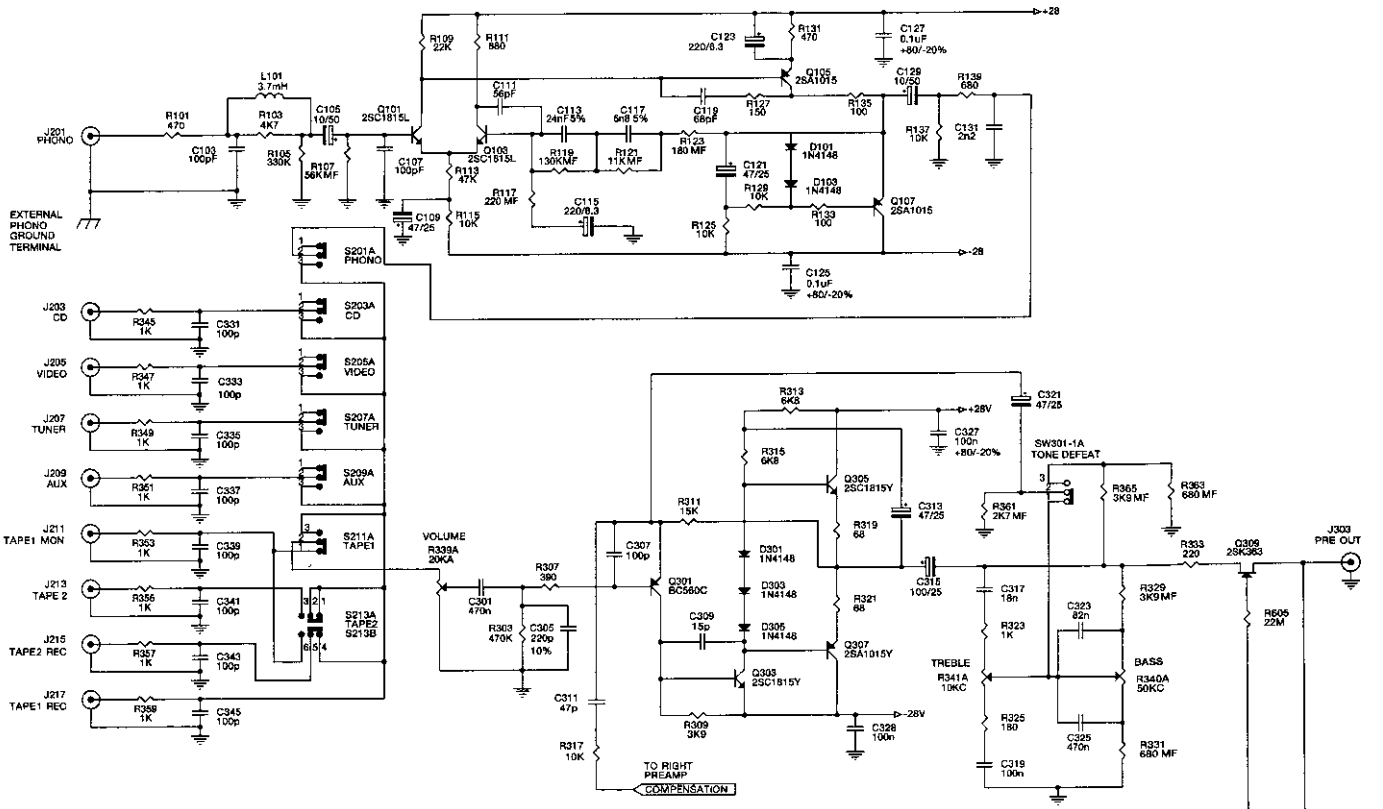

LEFT PREAMP

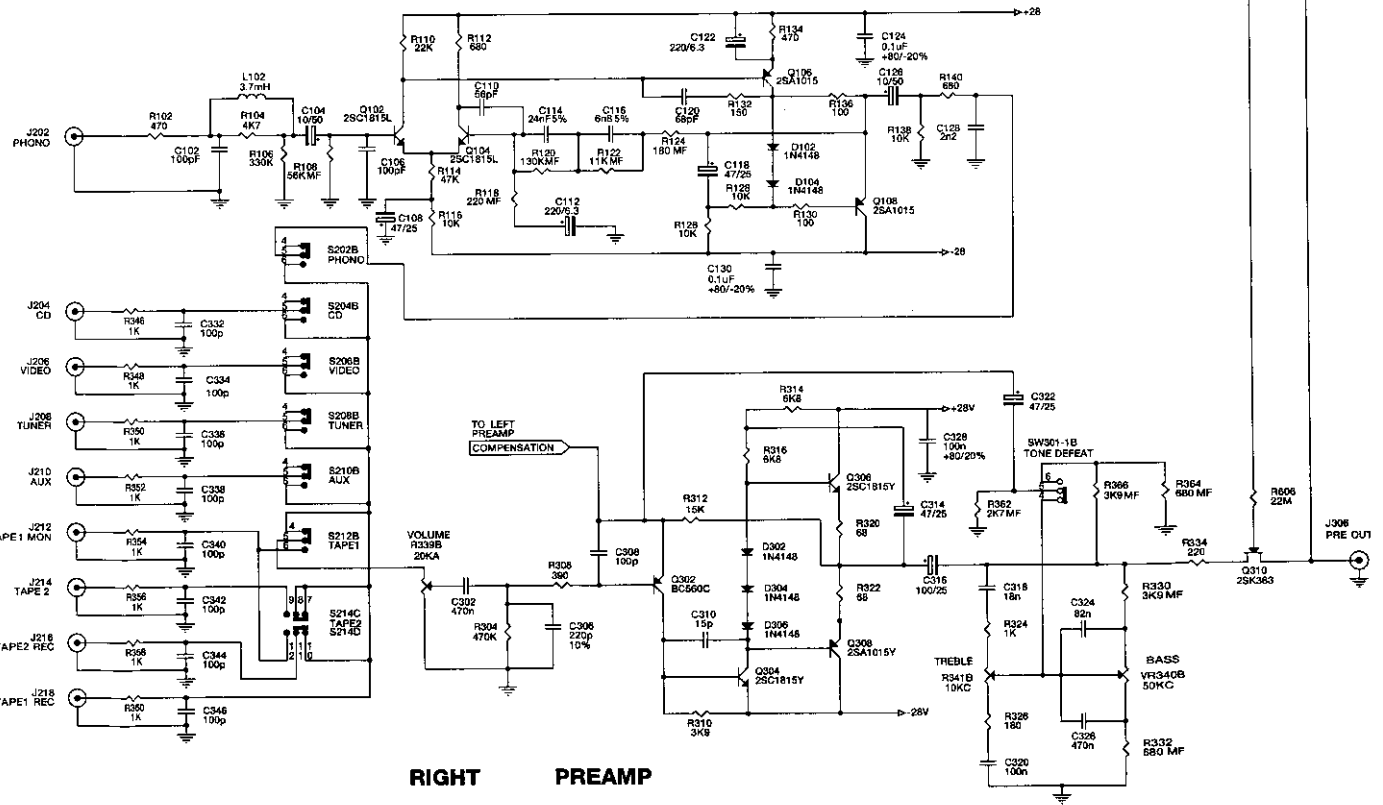

RIGHT PREAMP

NOTE: 1. RESISTORS, UNLESS OTHERWISE SPECIFIED ARE 1/4W.
 2. ALL CERAMIC CAPACITORS, UNLESS OTHERWISE SPECIFIED ARE 50V, 5%.

RESISTORS:
 MF - METAL FILM
 UNLESS SPECIFIED
 ARE CARBON FILM.

	E C B		D G S		C B E
	25A1015		25K383		BC590

POWER AMPLIFIER

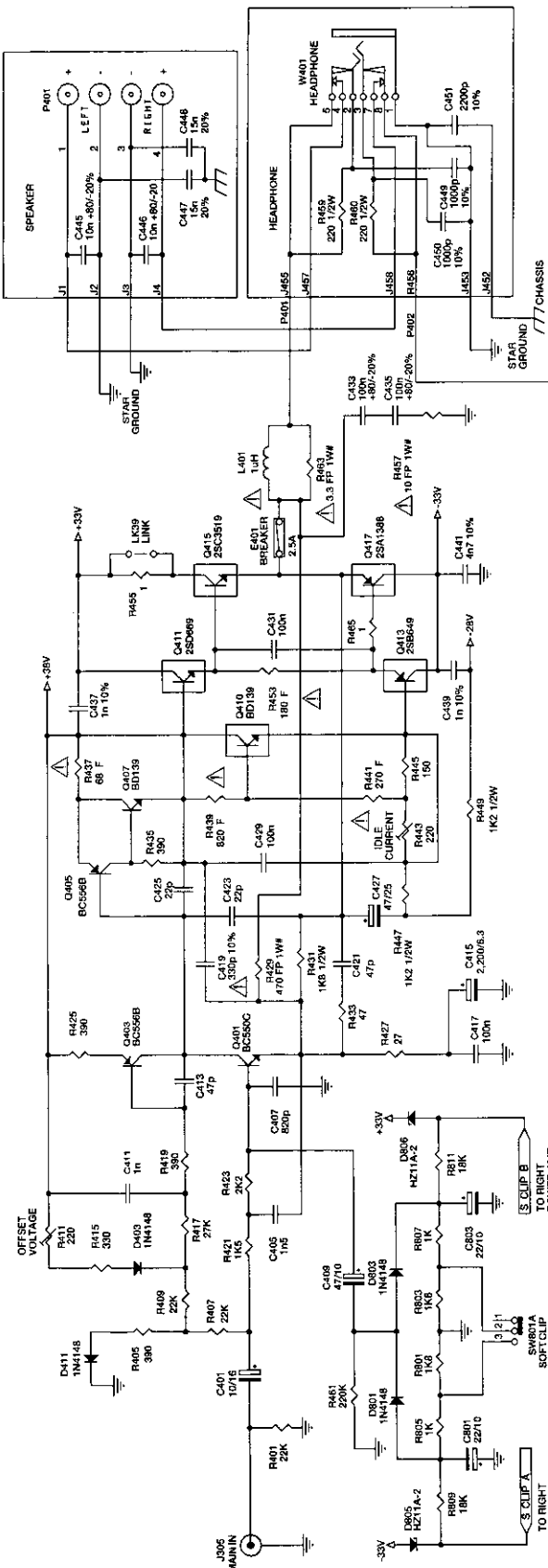

LEFT POWER AMP

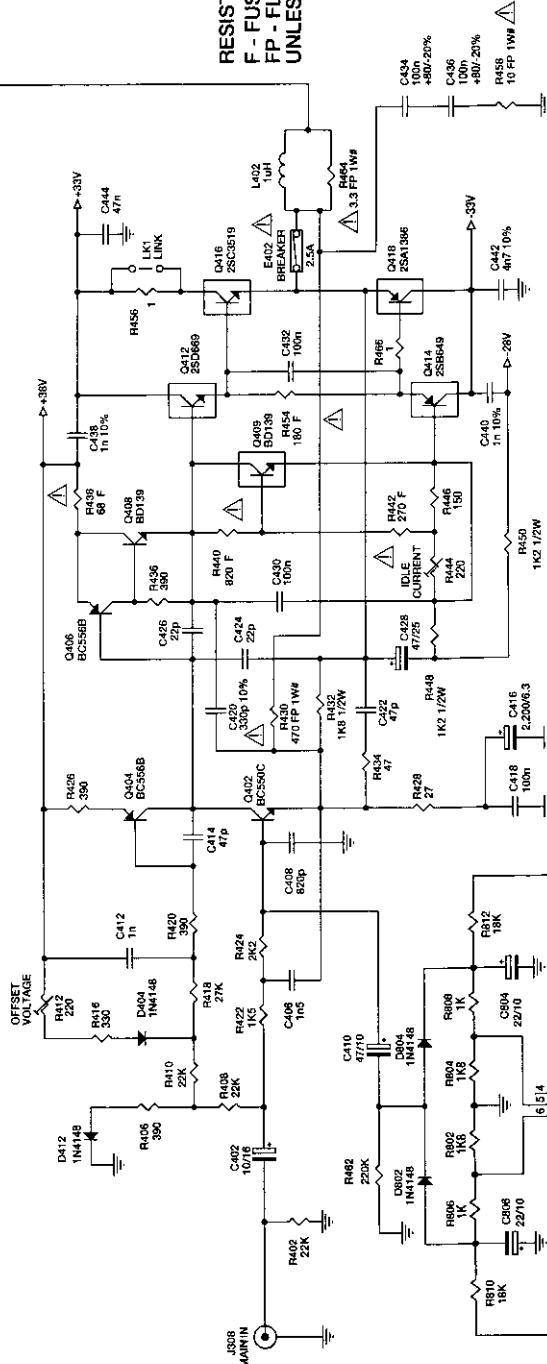

RIGHT POWER AMP

RESISTORS:
F - FUSIBLE
FP - FLAME PROOF
UNLESS SPECIFIED ARE CARBON FILM.

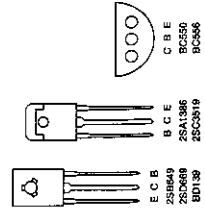

- NOTE: 1. RESISTORS, UNLESS OTHERWISE SPECIFIED ARE 1/4W.
 2. ALL CERAMIC CAPACITORS, UNLESS OTHERWISE SPECIFIED ARE 50V, 5%.
 3. BLOCKED TRANSISTORS ARE MOUNTED ON MAIN HEATSINK.
 4. COMPONENTS MARKED WITH "△" ARE SAFETY CRITICAL PARTS.
 5. COMPONENTS MARKED WITH "# " ARE ELEVATED FROM PCB.

POWER SUPPLY

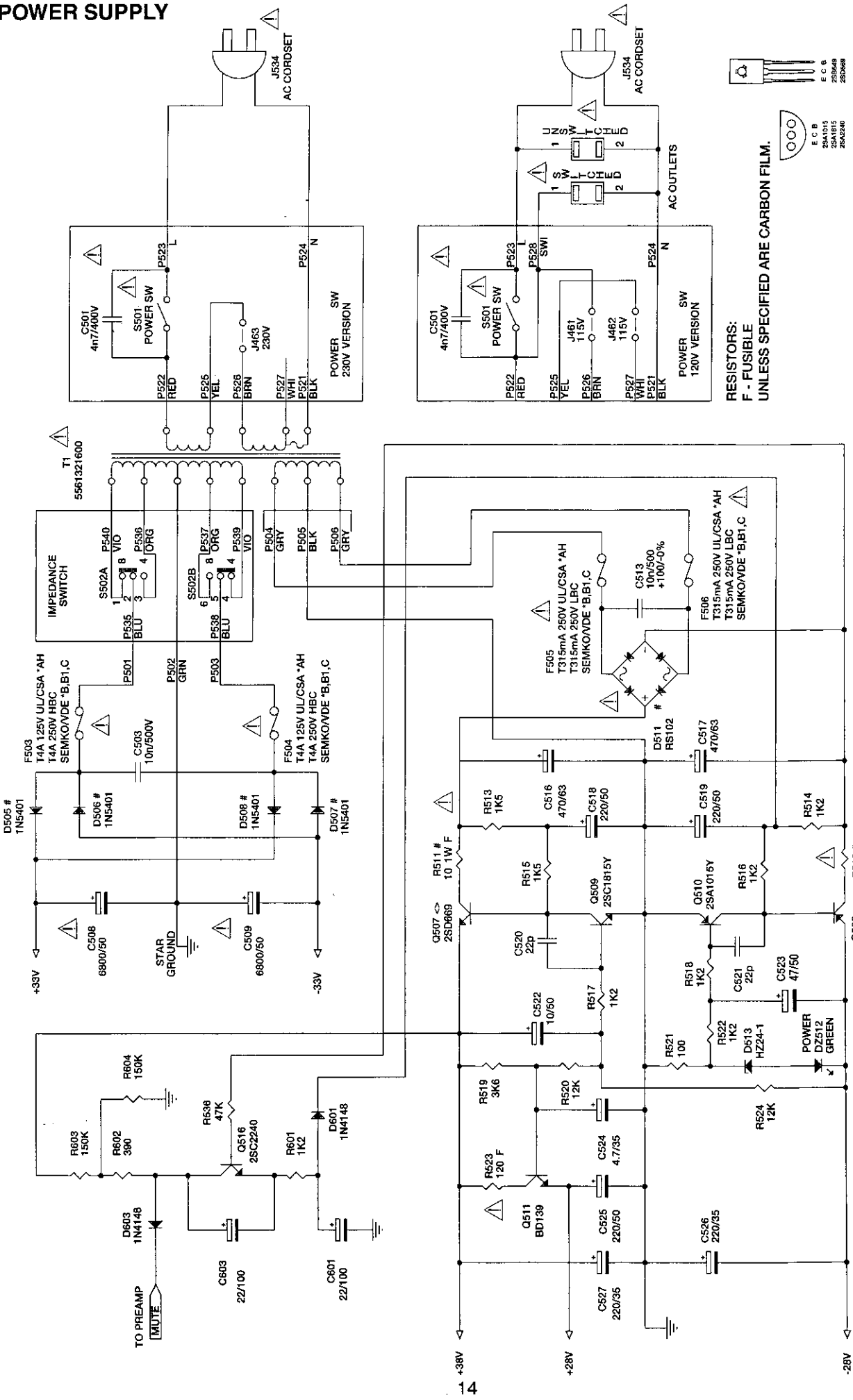

- NOTE:**
1. RESISTORS, UNLESS OTHERWISE SPECIFIED ARE 1/4W.
 2. ALL CERAMIC CAPACITORS, UNLESS OTHERWISE SPECIFIED ARE 50V, 5%.
 3. COMPONENTS MARKED WITH "△" ARE SAFETY CRITICAL PARTS.
 4. COMPONENTS MARKED WITH " # " ARE ELEVATED FROM PCB.
 5. COMPONENTS MARKED WITH " <> " ARE MOUNTED ON SMALL HEATSINK.

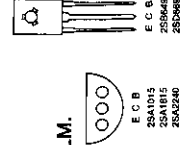

POWER SUPPLY

EXPLODED VIEW

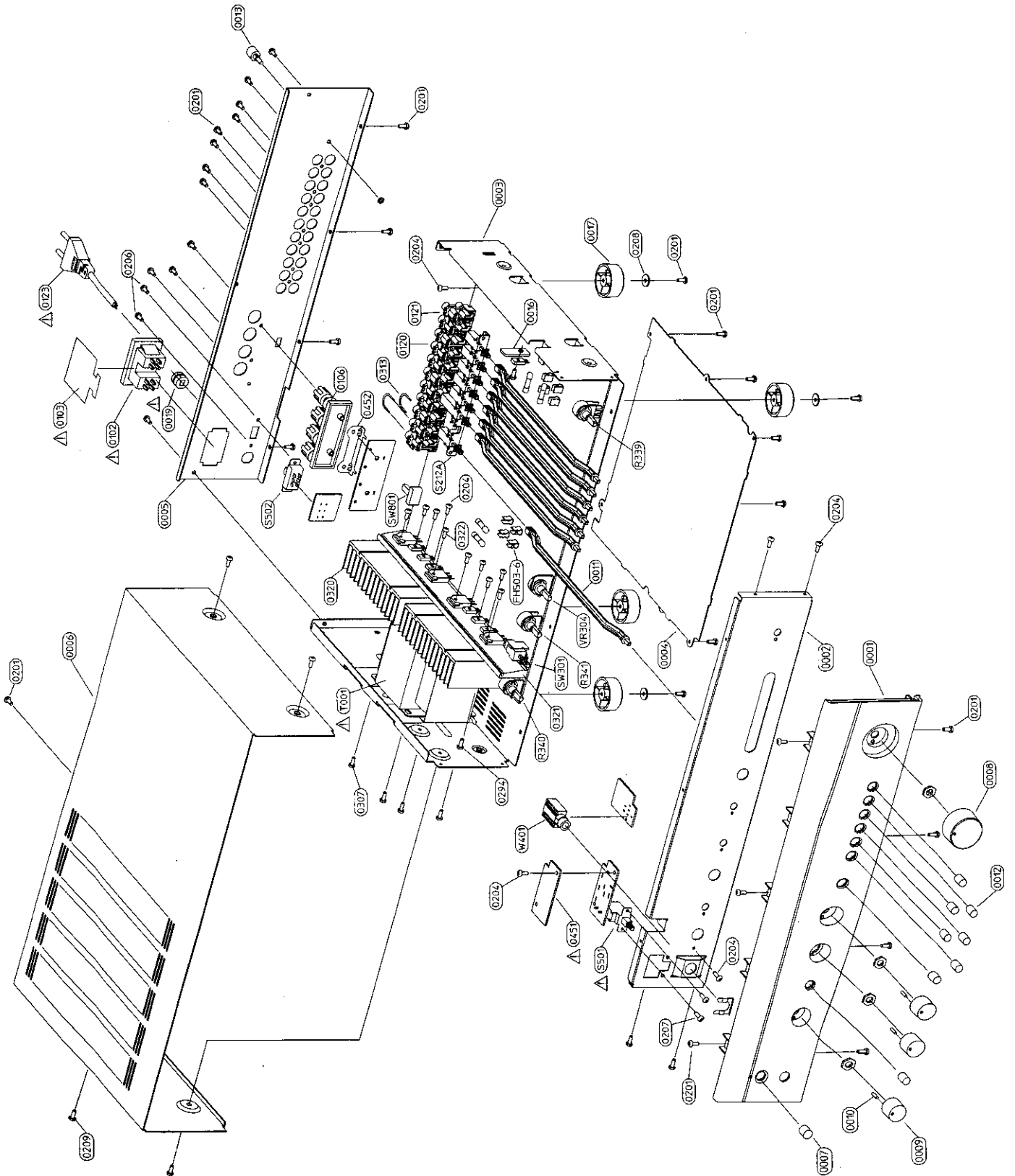

EXPLODED VIEW PARTS LIST

<u>Item</u>	<u>Part No</u>	<u>Description</u>	<u>Qty</u>
0001	N14627711-0	FASCIA	1
0002	N14023700-0	SUBFASCIA	1
0003	N14023800-0	CHASSIS	1
0004	N14023810-0	BASE COVER	1
0005*AH	N14023741-1	REAR PANEL	1
0005*B,B1,C	1402-3752-1	REAR PANEL	1
0006	N14023840-0	TOP COVER	1
0007	N2437510B-0	DIA 9.5 GLOSS POWER BUTTON	1
0008	N24375601-0	KNOB 35.0MM (VOLUME)	1
0009	N24375701-1	KNOB 18.5MM(BASS,TREBLE,BALANCE)	3
0010	N41520041-0	POINTER	4
0011	N24376101-0	BUTTON EXTENDER	7
0012	N24376001-0	LONG BUTTON 8.0MM	8
0013	N41321181-0	THUMB SCREW ASSY	1
0016	5400-1051-0	HEATSINK PLATE 28X12X2T	2
0017	N41519371-1	RUBBER FOOT 14.8MM HIGH	4
0019 △	N41519461-0	STRAIN RELIEF BUSHING	1
0102*AH △	2103-7701-2	AC OUTLET	1
0103*AH △	N41519941-0	AC OUTLET COVER PLATE	1
0106	2103-6604-1	SPK TERMINAL	1
0120	2113-0206-0	6P RCA R/W NI	3
0121	2113-0104-0	4P RCA R/W AU	1
0123*AH △	N70093100-1	AC CORD	1
0123*B △	N70095110-1	AC CORD	1
0123*B1 △	N70091190-1	AC CORD	1
0123*C △	N70093110-1	AC CORD	1
0201	2954-3008-3000	TAPPING 3X8MM B-TITE (BLK.ZN)	34
0204	2954-3008-0000	TAPPING 3X8MM B-TITE (YEL.ZN)	22
0206	2944-3006-3000	SCREW D3X6 S-TITE BH,BK	2
0207	2904-3006-0000	SCREW M3X6	2
0208	2842-3367-0	METAL WASHERID=3.3 OD=6.7	4
0209	2900-4006-3010	M4X0.5PX6MM W/FLATWASHER	4
0294	2950-3006-0000	3X6MM PAN HEAD (YEL.ZN)	4
0307	2900-4006-3010	M4X0.5PX6MM W/FLAT WASHER	4
0313	4132-2731-0	U-SHORTING BAR 14MM	2
0320	5400-1081-1	HEAT SINK EXTRUSION	2
0321	5400-1071-1	HEAT SINK BAR	1
0322	2904-3010-0000	M3X10MM (YEL.ZN)	4
0451 △	4152-1031-0	PWR-PCB COVER PLATE	1
0452	N14024000-0	SPEAKER GROUND BRACKET	1
FH503-6	N41321011-0	FUSE HOLDER (5X20MM)	8
R339	N47503666-0	VR-VOL 2X20KA W/WASHER & NUT	1
R340	N47503676-0	VR-BASS 2X50KC W/WASHER & NUT	1
R341	N47503646-0	VR-TRE 2X10KC W/WASHER & NUT	1

<u>Item</u>	<u>Part No</u>	<u>Description</u>	<u>Qty</u>
VR304	N47503656-0	VR-BAL 1X10KW W/WASHER & NUT	1
S212A	5200-3421-0	SELECT SWITCH	1
S501 △	5200-3431-0	POWER SWITCH W/M3 THREAD	1
S502	N52003031-0-01	SLIDE SWITCH 5.2T22SS28G10	1
SW301	N52003121-0-01	2P2T ALPS SPUN W/O FRAME	1
SW801	N52003131-0-01	2P2T SLIDE SW 3.5T22KYGX	1
T001 △	N18062120-1	TRANSFORMER W/M4H/L-WIRE	1
W401	2113-1011-0	PHONE JACK 6312-03-070 W/CLIP	1

- NOTE :** - The components identified by △ mark are critical for risk of fire and electrical shock.
 Replace only with part number specified.
- <*AH > : USA, Canadian model only.
 - <*B > : UK model only.
 - <*B1 > : Australian model only.
 - <*C > : European model only.

ELECTRICAL PARTS LIST

Reference No	Part Number	Description
PC BOARD	MI-21100-01-S	312 MAIN ASSEMBLY
CAPACITORS		
C104-C105	157F-106M-5-IU	CE 50V 10 μ F 20%
C108-C109	157E-476M-5-IU	CE 25V 47 μ F 20%
C112	157B-227M-5-KW	CE 6.3V 220 μ F 20%
C113-C114	153F-243J-5-OW	CM 50V 0.024 μ F 5%
C115	157B-227M-5-KW	CE 6.3V 220 μ F 20%
C116-C117	153F-682J-5-JQ	CM 50V 6800pF 5%
C118, C121	157E-476M-5-IU	CE 25V 47 μ F 20%
C122-C123	157B-227M-5-KW	CE 6.3V 220 μ F 20%
C126, C129	157F-106M-5-IU	CE 50V 10 μ F 20%
C128-C131	153F-222J-5-KW	CM 50V 2200pF 5%
C301-C302	153I-474J-9-NO	CM 63V 0.47 μ F 5%
C313-C314	157E-476M-5-IU	CE 25V 47 μ F 20%
C315-C316	157E-107M-5-KW	CE 25V 100 μ F 20%
C317-C318	153F-183J-5-LW	CM 50V 0.018 μ F 5%
C319-C320	153F-104J-5-SY	CM 50V 0.1 μ F 5%
C321-C322	157E-476M-5-IU	CE 25V 47 μ F 20%
C323-C324	153F-823J-5-SY	CM 50V 0.082 μ F 5%
C325-C326	153I-474J-9-NO	CM 63V 0.47 μ F 5%
C401-C402	157D-106M-5-IU	CE 16V 10 μ F 20%
C405-C406	153F-152J-5-KW	CM 50V 1500pF 5%
C407-C408	153F-821J-5-HS	CM 50V 820pF 5%
C409-C410	157C-476M-5-IU	CE 10V 47 μ F 20%
C411-C412	153F-102J-5-IM	CM 50V 1000pF 5%
C415-C416	157B-228M-5-Z@	CE 6.3V 2200 μ F 20%
C417-C418	153F-104J-5-SY	CM 50V 0.1 μ F 5%
C427-C428	157E-476M-5-IU	CE 25V 47 μ F 20%
C429-C432	153F-104J-5-SY	CM 50V 0.1 μ F 5%
C501	N89100049-0	CAP400V 4700pF DE7150F472MVA1KC
C508-C509	N89100029-0	CE 50V 6800 μ F 20%
C516-C517	157I-477M-5-Y@	CE 63V 470 μ F 20%
C518-C519	157F-227M-5-S5	CE 50V 220 μ F 20%
C522	157F-106M-5-IU	CE 50V 10 μ F 20%
C523	N157F476M-5-PV	CE 50V 47 μ F 20%
C524	N157Q476M-5-LU	CE 35V 47 μ F 20%
C525-C527	157F-227M-5-S5	CE 50V 220 μ F 20%
C601, C603	N157H226M-5-PV	CE 100V 22 μ F 20%
C801, C803-C804, C806	157C-226M-5-IU	CE 10V 22 μ F 20%
DIODES		
D101-D104	4804-1480-2	DIODE 1N4148
D301-D306	4804-1480-2	DIODE 1N4148
D403-D404	4804-1480-2	DIODE 1N4148
D411-D412	4804-1480-2	DIODE 1N4148
D505-D508	N48054010-1	DIODE 1N5401 100V 3A
D511	N48400470-0	BRIDGE RECTIFIER RS102 100V 1A
D512	N37002489-G	LED 3MM GREEN
D513	4840-0790-0	DZ 1/2W 22.9-24 HZ24V-1
D601, D603	4804-1480-2	DIODE 1N4148
D801-D804	4804-1480-2	DIODE 1N4148
D805-D806	4837-8A20-2	DZ 1/2W 9.7-10.1

Reference No	Part Number	Description
BREAKERS		
E401-E402 ▲	8910-0088-0	BREAKER 2.5A A-25
INDUCTORS		
L101-L102	N18030013-0	TOROID INDUCTOR 3.7MH +-20%
L401-L402	1804-0540-0	SPRING COIL 1µH
TRANSISTORS		
Q101-Q104	N48600710-5	TR 2SC1815L GR
Q105-Q108	N48600660-5	TR 2SA1015GR
Q301-Q301	N485C560C-5	TR BC560C
Q303-Q306	N4851815Y-5	TR 2SC1815-Y HFE 120-240
Q307-Q308	N4851015Y-5	TR 2SA1015-Y HFE 100-200
Q309-Q310	N485363BL-5	TR N-JEET 2SK-363BL
Q401-Q402	N485C550C-5	TR BC550C
Q403-Q406	N485C556B-5	TR BC556B
Q407-Q410	N485D1390-5	TR BD139-10 PHILIPS HFE 63-160
Q411-Q413	N485669AC-5	TR 2SD669A-C
Q413-Q414	N485649AC-5	TR 2SB649A-C HFE 100-200
Q415-Q416	N48600730-5	TR 2SC3519 (0,P,Y)
Q417-Q418	N48600690-5	TR 2SA1386 (0,P,Y)
Q507	N485669AC-5	TR 2SD669A-C
Q508	N485649AC-5	TR 2SB649A-C HFE 100-200
Q509	N4851815Y-5	TR 2SC1815-Y HFE 120-240
Q510	N4851015Y-5	TR 2SA1015-Y HFE 100-200
Q511	N485D1390-5	TR BD139-10 PHILIPS HFE 63-160
Q516	N485240GR-5	TR 2SC2240GR
RESISTORS		
R107-R108	4715-563C-2	RMF 56k Ohm 1/4W 2%
R117-R118	4715-221C-2	RMF 220 Ohm 1/4W 2%
R119-R120	4715-134C-2	RMF 130k Ohm 1/4W 2%
R121-R122	4715-113C-2	RMF 11k Ohm 1/4W 2%
R123-R124	4715-181C-2	RMF 180 Ohm 1/4W 2%
R329-R330	4715-392C-2	RMF 3.9k Ohm 1/4W 2%
R331-R332	4715-681C-2	RMF 680 Ohm 1/4W 2%
R361-R362	4715-272C-2	RMF 2.7k Ohm 1/4W 2%
R363-R364	4715-681C-2	RMF 680 Ohm 1/4W 2%
R365-R366	4715-392C-2	RMF 3.9k Ohm 1/4W 2%
R429-R430 ▲	4718-471J-1-X	RFP 470 Ohm 1W 5%
R437-R438 ▲	4715-680J-2-F	RFU 68 Ohm 1/4W 5%
R439-R440 ▲	4715-821J-2-F	RFU 820 Ohm 1/4W 5%
R441-R442 ▲	4715-271J-2-F	RFU 270 Ohm 1/4W 5%
R453-R454 ▲	4715-181J-2-F	RFU 180 Ohm 1/4W 5%
R457-R458 ▲	4718-100J-L-P	RFP 10 Ohm 1W 5%
R463-R464 ▲	4718-3R3J-1-X	RFP 3.3 Ohm 1W 5%
R511 ▲	N4718100J-L-F	RFU 10 Ohm 1W 5%
R512 ▲	4719-101J-L-F	RFU 100 Ohm 2W 5%
R523 ▲	4715-121J-2-F	RFU 120 Ohm 1/4W 5%
VARIABLE RESISTORS		
R411-R412	4756-2216-3-06	SVR 220 H3 7X7.6
R443-R444	4756-2216-3-06	SVR 220 H3 7X7.6

<u>Reference No</u>	<u>Part Number</u>	<u>Description</u>
FUSES		
F503-F504*AH △	5120-0019-0	FUSE 4A 125V SLOW BLOW LBC (UL/CSA)
F503-F504*B,B1,C △	5120-0017-0	FUSE 4A 250V TIME LAG HBC (SEMKO/VDE)
F505-F506*AH △	5120-0026-0	FUSE 315mA 250V TIME LAG LBC (UL/CSA)
F505-F506*B,B1,C △	5120-0027-0	FUSE 315mA 250V TIME LAG LBC (SEMKO/VDE)

- NOTE :** - The components identified by △ mark are critical for risk of fire and electrical shock.
 Replace only with part number specified.
- <*AH > : USA, Canadian model only.
 - <*B > : UK model only.
 - <*B1 > : Australian model only.
 - <*C > : European model only.
 - Capacitors : CM-Mylar, CE-Electrolytic.
 - Resistors : RMF-Metal Film, RFU-Fusible, RFP-Flame Proof.

PACKING DIAGRAM

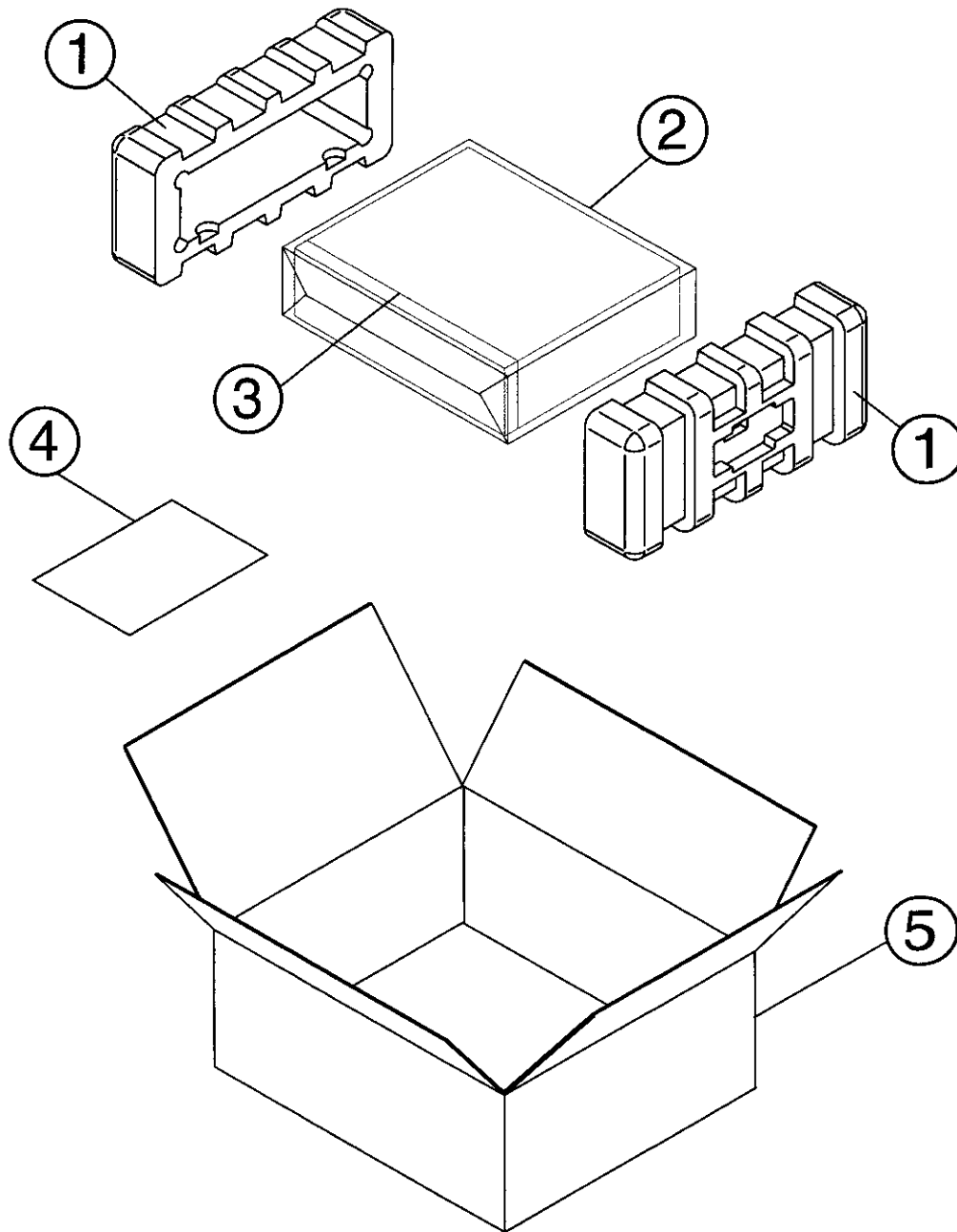

PACKING LIST

<u>Item</u>	<u>Part No</u>	<u>Description</u>	<u>Qty</u>
1	1490-1843-1	POLYFOAM END CAP	2
2	N14971332-1	UNIT POLYBAG	1
3	N14971442-0	FASCIA COVER	1
4	N43013569-0	INSTRUCTION MANUAL	1
5	N14763901-0	CARTON BOX	1

SERVICE MANUAL

Proprietary information for servicing purposes only. The information herein may not be used commercially without the prior written agreement of NAD Electronics Ltd., London, England.

© NAD 1995

312
STEREO INTEGRATED
AMPLIFIER

NAD ELECTRONICS
LONDON