

AKAI SERVICE MANUAL

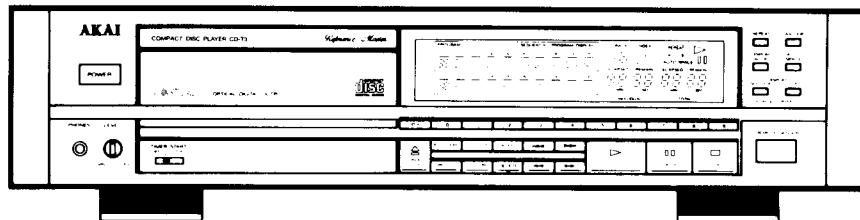

COMPACT DISC PLAYER MODEL CD-73



I. SPECIFICATIONS

System	Compact disc player	Headphone output level/	
Pick-up system	3 beam Laser pick up	Impedance	28 mW/32 ohms
Sampling frequency	44.1 kHz	Spindle motor	Brush-less D.D. motor
Digital filter	18 bit, 4 times over sampling	Power requirements	120 V, 60 Hz for USA & Canada
D/A converter	16 bit linear		220 V, 50 Hz for Europe except UK
Error correction system	Cross Interleave Reed Solomon		240 V, 50 Hz for UK & Australia
Number of channels	2 channels (Stereo)		110V-120V/220V-240V, 50 Hz/60 Hz convertible for other countries
Frequency response	5 Hz to 20 kHz \pm 0.3 dB	Dimensions	425 (W) \times 112 (H) \times 330 (D) mm (16.7 \times 4.4 \times 13.0 inches)
Dynamic range	97 dB or more	Weight	7.5 kg (16.6 lbs)
S/N	106 dB or more		
Total harmonic distortion	0.0025% or less		
Wow & Flutter	Less than measurable limits		
Analogue output level	2 V (0 dB)		
Digital output level/ Impedance			
Coaxial	0.5 Vp-p/75 ohms		
Optical	Min. -20 dBm, Max. -15 dBm, wave length 660 nm		

* For improvement purposes, specifications and design are subject to change without notice.

★ SAFETY INSTRUCTIONS

PRECAUTIONS DURING SERVICING

- Parts identified by the \triangle symbols are critical for safety. Replace only with parts number specified.
- In addition to safety, other parts and assemblies are specified for conformance with such regulations as those applying to spurious radiation. These must also be replaced only with specified replacements.
Examples: RF converters, tuner units, antenna selector switches, RF cables, noise blocking capacitors, noise blocking filters, etc.
- Use specified internal wiring. Note especially:
 - Wires covered with PVC tubing
 - Double insulated wires
 - High voltage leads
- Use specified insulating materials for hazardous live parts. Note, especially:
 - Insulation Tape
 - PVC tubing
 - Spacers (Insulating Barriers)
 - Insulation sheets for transistors
 - Plastic screws for fixing microswitch (especially in turntable)
- When replacing AC primary side components (transformers, power cords, noise blocking capacitors, etc.), wrap ends of wires securely about the terminals before soldering.

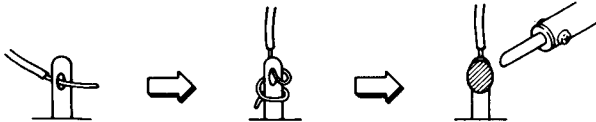

- Observe that wires do not contact heat producing parts (heatsinks, oxide metal film resistors, fusible resistors, etc.).

- Check that replaced wires do not contact sharp edged or pointed parts.
- Also check areas surrounding repaired locations.
- Use care that foreign objects (screws, solder droplets, etc.) do not remain inside the set.

SAFETY CHECK AFTER SERVICING

Confirm the specified insulation resistance between power cord plug prongs and externally exposed parts of the set is greater than 10 M ohms, but for equipment with external antenna terminals (tuner, receiver, etc.) and is intended for $\square C$ or $\square A$, specified insulation resistance should be headphone jacks, line-in-out jacks, etc. more than 2.2 M ohms (ground terminals, microphone jacks).

BEFORE USING THE CD PLAYER

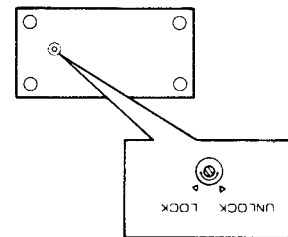

On the Transport Locking Lever

This CD player has a Transport Locking Lever located on the bottom panel. This lever locks the laser pick up mechanism to prevent vibration during transportation. Make sure to set this lever to the UNLOCK position before playback.

Raise the CD player as shown in the illustration (Front panel facing up), and then turn the Transport Locking Lever to the UNLOCK position.

When transporting the CD player

Make sure to remove the compact disc from the CD player, and reset the Transport Locking Lever to the LOCK position.

★ INFORMATION

SYMBOLS FOR PRIMARY DESTINATION

Alphabet indicates the destination of the units as listed below.

Symbols	Principal Destinations
$\square A$	USA
$\square B$	UK
$\square C$	Canada
$\square E$	Europe (except UK)
$\square J$	Japan
$\square S$	Australia
$\square V$	W. Germany only
$\square U$	Universal Area
$\square Y^*$	Custom version

VOLTAGE CONVERSION ($\square U$ Model only)

Before connecting the power cord, SET the VOLTAGE SELECTOR located on the rear panel with a screw driver so that the correct voltage is indicated.

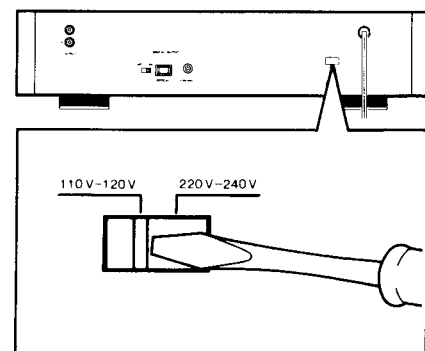

PRECAUTIONS IN REPAIRING

When repairing or adjusting the unit, please note the following points.

1. Do not put excessive pressure on the mechanical part (operation part), including the pick-up block, as extremely high mechanical precision is required in these parts.
2. When the base is removed for repair or adjustment, make sure that there are no metal objects in the narrow gap between the P.C. board or the mecha parts and the base.
3. The Micro-Computer and the CD signal processing ICs can be damaged by static electricity or leakage from a soldering iron during repairing.

While soldering, please take the precautions against leakage as in the illustration.

4. Do not loosen any screws in the pick-up block. When handling the pick-up block, please refer to the points to NOTE when replacing the pick-up block.
5. Keep safety from hazardous invisible Laser Radiation. DO NOT watch the Laser Beam (Objective Lens) directly.
6. Models for the same countries, Laser Warning Labels are affixed on the unit and inside of the unit, as shown below. Read it carefully for your safety, when repairing or adjusting the unit.

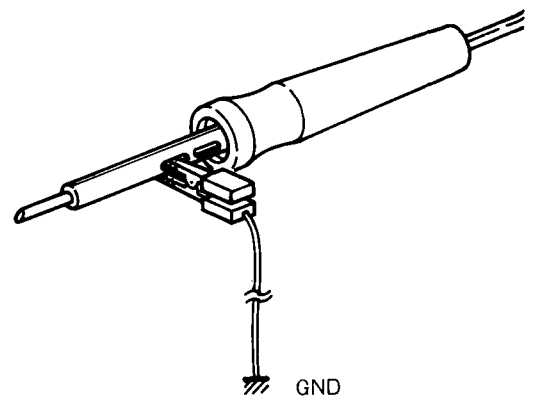

[DENMARK and U.K]



A Label affixed on the Rear panel of the unit

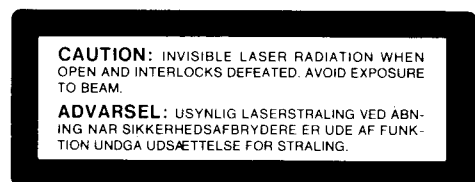

A Label affixed on the HOLDER STABILIZER the unit

[U.S.A]

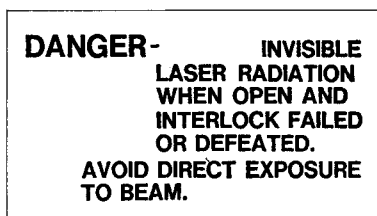

A Label printed on the Rear panel of the unit.

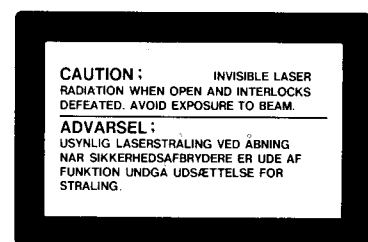

A Label affixed on the HOLDER STABILIZER the unit.

I. CONTROLS

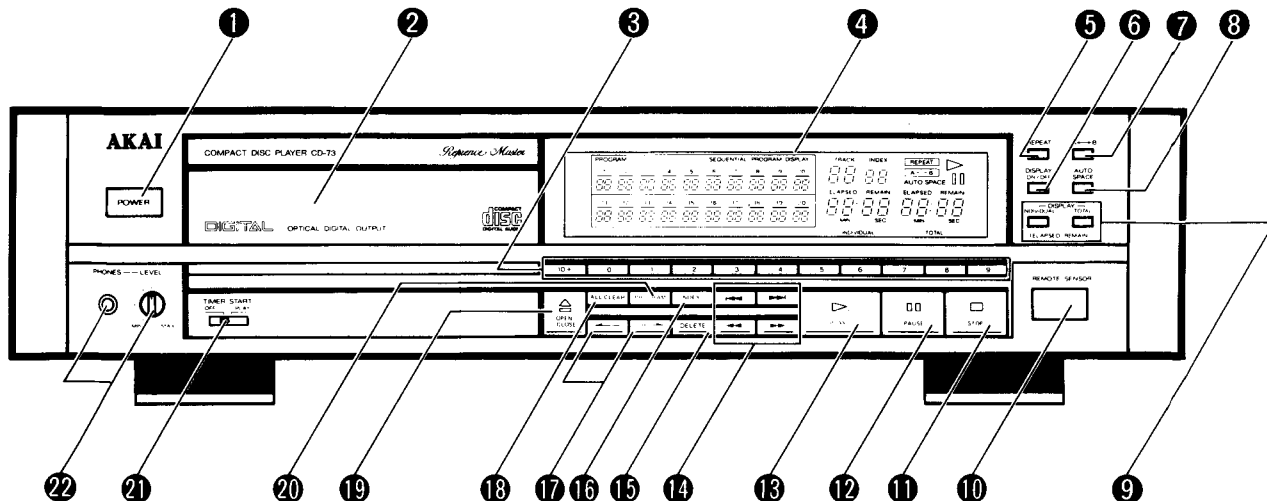

- 1 POWER Button**
To turn the power on and off.
- 2 Disc drawer**
Load a compact disc here.
- 3 Numeric Buttons (10+ and 0 to 9)**
For direct search of the track you wish to play back and for programming for random program playback.
- 4 FL (Fluorescent) display**
Tells you what the Akai CD player is doing.
- 5 REPEAT Button**
For repeat playback of all the tracks or the random program.
- 6 DISPLAY ON/OFF Button**
To turn the FL display on and off.
- 7 A ↔ B Button**
For repeat playback of a specific section of the CD.
- 8 AUTO SPACE Button**
To set the blank intervals between tracks to a specific time (approximately 4 seconds) for uniformity during playback.
- 9 DISPLAY INDIVIDUAL and TOTAL Buttons**
To select between remaining time and elapsed time displays.
- 10 REMOTE SENSOR Window**
For reception of the remote control signal.
Keep away from strong light and direct sunlight as this will interfere with the remote control function.
- 11 □ STOP Button**
To stop playback.
- 12 ∞ PAUSE Button**
To stop playback temporarily.
- 13 ▷ PLAY Button**
To start playback.
- 14 Search Buttons (↔ / ↔ and ← / →)**
For manual search and to skip tracks during playback.
- 15 DELETE Button**
To delete a programmed track.
- 16 INDEX Button**
For index search playback.
- 17 Cursor Control Buttons (← / →)**
To move the cursor during programming.
- 18 ALL CLEAR Button**
To cancel all the programmed tracks.
- 19 ≙ OPEN/CLOSE Button**
To open and close the disc drawer.
- 20 PROGRAM Button**
For random program playback.
- 21 TIMER START OFF/PLAY Switch**
For timed playback operation.
- 22 PHONES Jack and LEVEL Control**
For headphone listening.

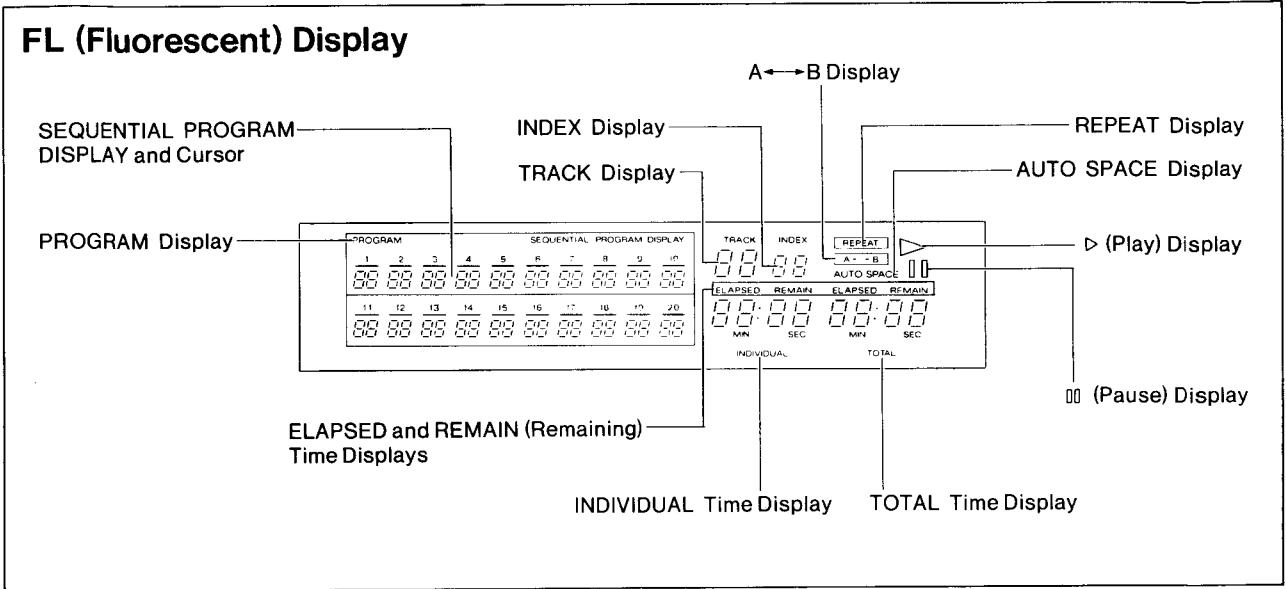

Control (CD player)

The operation buttons on the remote control unit are the same as those on the Akai CD player and can be used to conveniently control all the CD player's functions.

Transmitting window

△ (Open/Close) Button

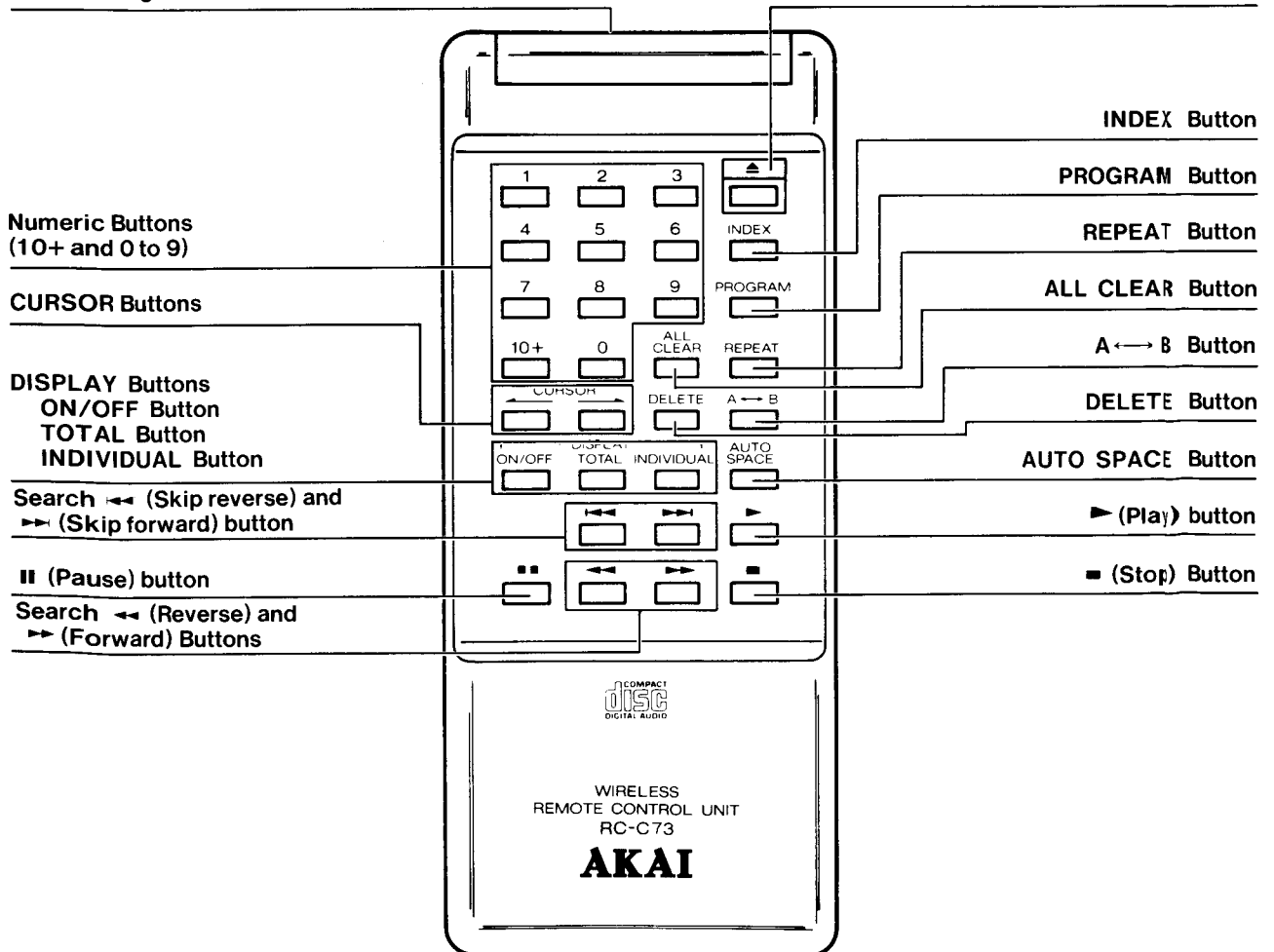

II. DISASSEMBLY

1. Removal of Upper Cover

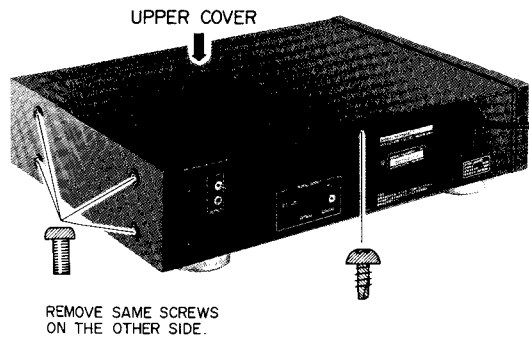

3.

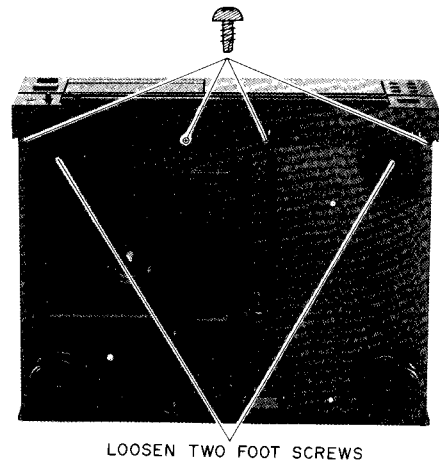

2. Removal of Front Panel

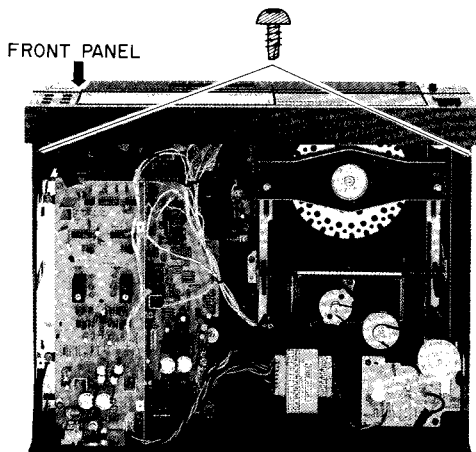

4. Removal of MECHA BLOCK

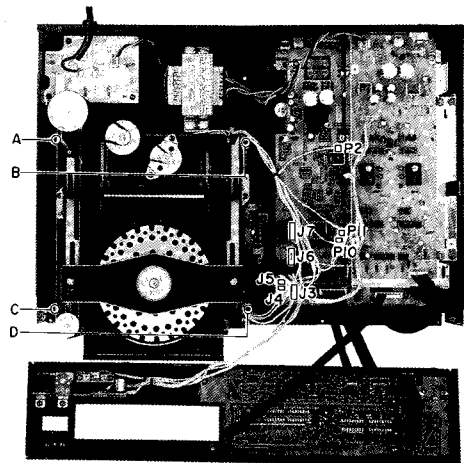

1. POWER ON. Depress the OPEN/CLOSE button to open the disc tray. Then turn the POWER OFF.
2. Remove the three connectors on the DIGITAL PCB: P10 to12, J3 (No. 3 to No. 6) to J7
3. Remove four Mecha chassis fixing screws A, B, C and D.

III. PRINCIPAL PARTS LOCATION

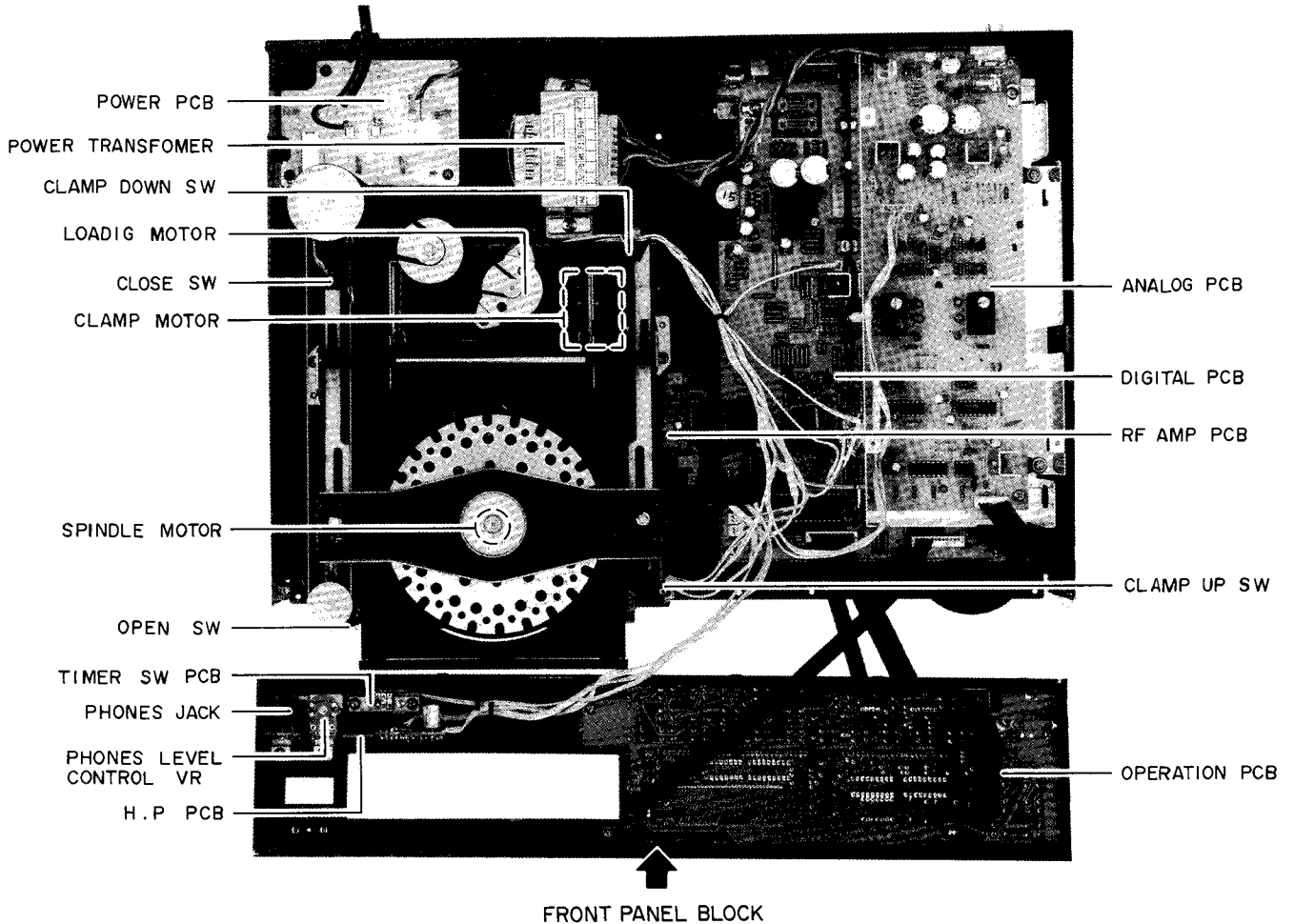

IV. REPLACEMENT OF THE PICK-UP BLOCK

PRECAUTIONS WHEN REPLACING THE PICK-UP BLOCK

- 1) The LD (Laser Diode) fixed on the pick-up block P.C. board can be damaged by static electricity or leakage from a soldering iron. Do not touch the P.C. board of the pick-up block, or use a tester to check if the electricity is on. When soldering, make sure that precautions are taken to prevent leakage from the soldering iron.
- 2) Avoid scratches, dirt or dust on the lens of the pick-up caused by touching with the fingers.
- 3) When connecting or disconnecting the RF AMP PCB (J201), make sure that the FLEXIBLE WIRING PCB is shorted circuit as shown in Fig. 4-1. Do not turn the electricity "ON" while it remains short-circuited.

- 4) For your safety from hazardous invisible Laser Radiation, replace only with pick-up block. Do not try to repair or the any adjustment.

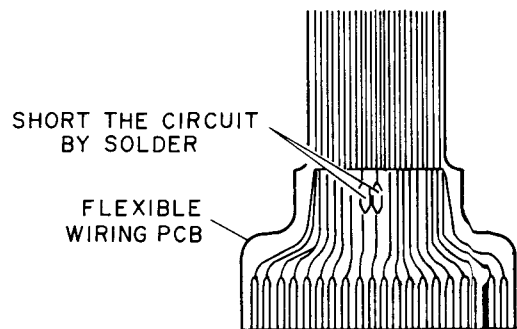

Fig 4-1

4-1. REMOVAL OF THE DISC TRAY (Refer to Fig 4-2, and 4-3)

- 1) Remove UPPER COVER and FRONT PANEL.
(Refer to II. DISASSEMBLY.)
- 2) Turn the power on and press the OPEN/CLOSE button to open the disc tray, then, turn the power off.
- 3) Remove the E-RING (A) and (B) on the HOLDER STABILIZER BLOCK.
- 4) Remove the screws (C) and (D) of the LEVER OUTSERT.
- 5) Remove the HOLDER STABILIZER BLOCK.
- 6) Remove the screws (E) to (H) and joint spring (I).

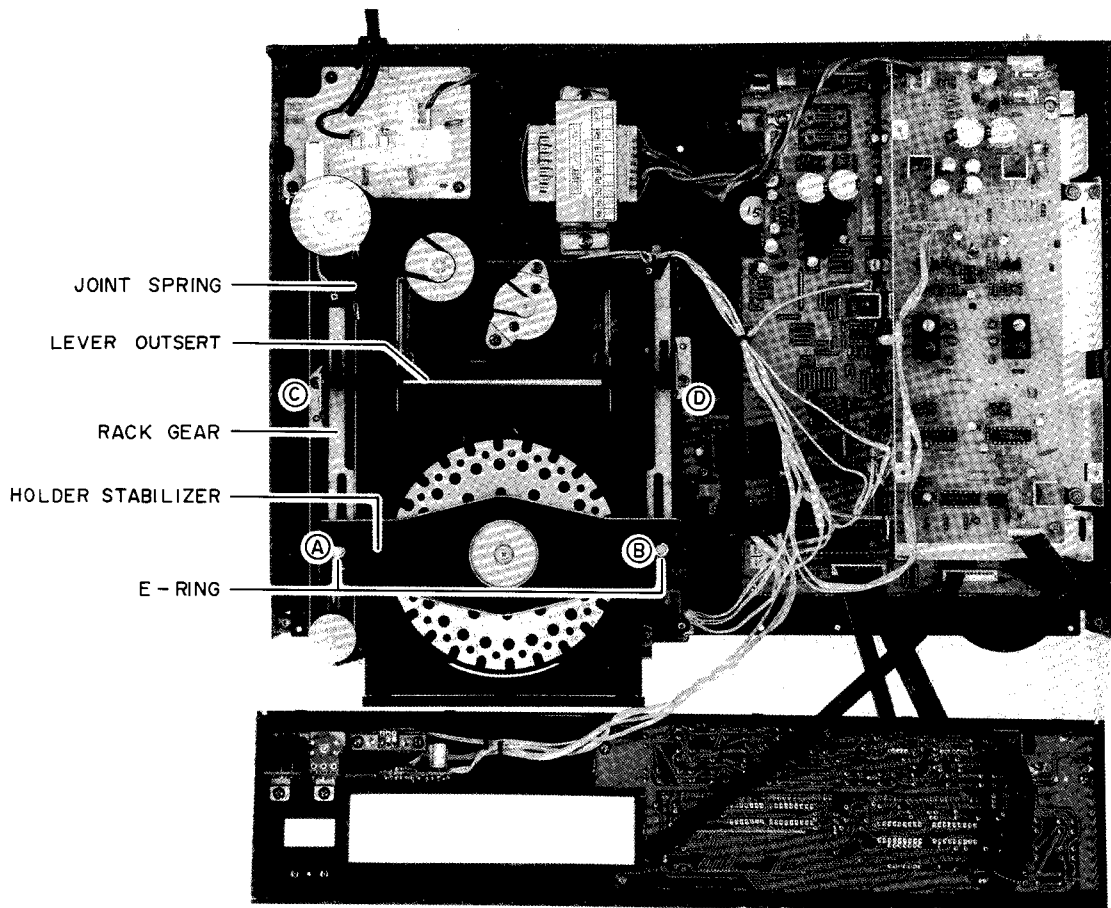

Fig. 4-2

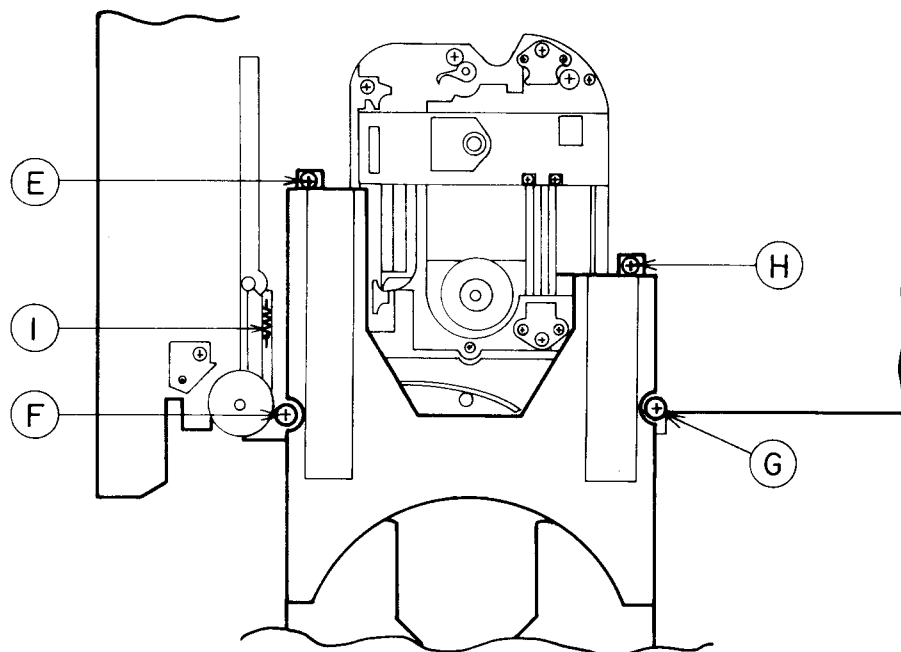

Fig. 4-3

4-2 REPLACING THE PICK-UP BLOCK

(Refer to Fig 4-4)

- 1) Remove the four mecha block fixing screws (A), (B), (C) and (D). (Refer to II. DISASSEMBLY.)
- 2) Disconnect the connector J201 on the RF AMP PCB.
- 3) Unsolder the four terminals (A), (B), (C) and (D) of the coils on the PICK-UP BLOCK.
- 4) Remove the six screws (E) to (J) of the GUIDE ARM and remove the PICK-UP BLOCK.
- 5) Install the new PICK-UP BLOCK and assemble in reverse order.

- NOTE:**
1. After replaced PICK-UP BLOCK, DO NOT TURN THE POWER ON BEFORE RESOLDER THE SHORT CIRCUIT ON THE FLEXIBLE WIRING PCB.
 2. After replaced PICK-UP BLOCK, all the adjustments in VI. SERVO ADJUSTMENT are necessary.
 3. Semi-fixed resistor VR1 on the PICK-UP BLOCK is adjusted at the factory according to each character of the pick-up, consequently, "DO NOT TOUCH THIS VR1".

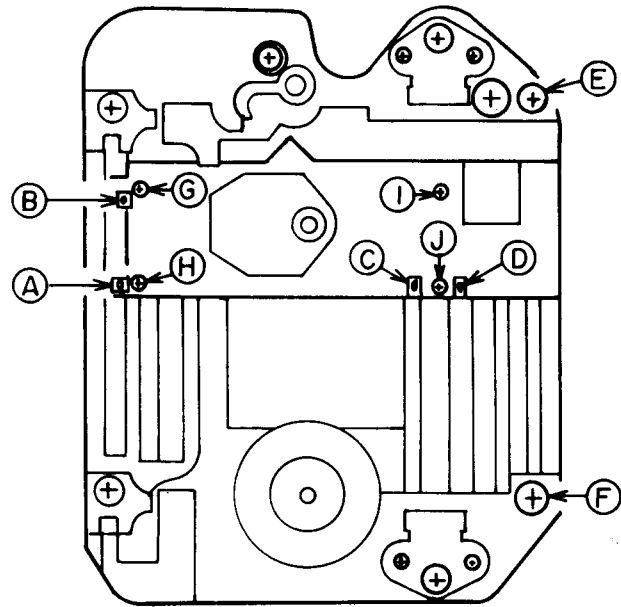

Fig. 4-4

V. REPLACEMENT OF THE SPINDLE MOTOR

- 1) Loosen the Hexagon set screw and pull out the TURN TABLE from the SPINDLE MOTOR.
- 2) Remove two SPINDLE MOTOR fixing screws.
- 3) Unsolder two SPINDLE MOTOR wires.
- 4) Solder two wires to new SPINDLE MOTOR.
- 5) Put the new SPINDLE MOTOR on the chassis with two screws.
- 6) Put the TURN TABLE on to the SPINDLE MOTOR shaft and adjust so that the height of the TURN TABLE from the diecast chassis becomes 32 ± 0.1 mm as shown in Fig 5-2.

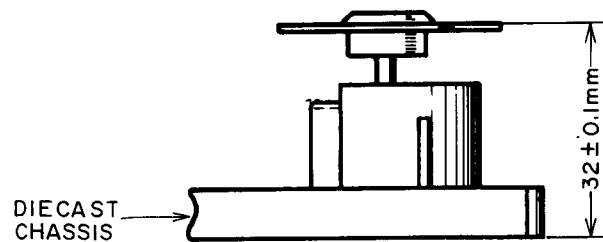

Fig. 5-2

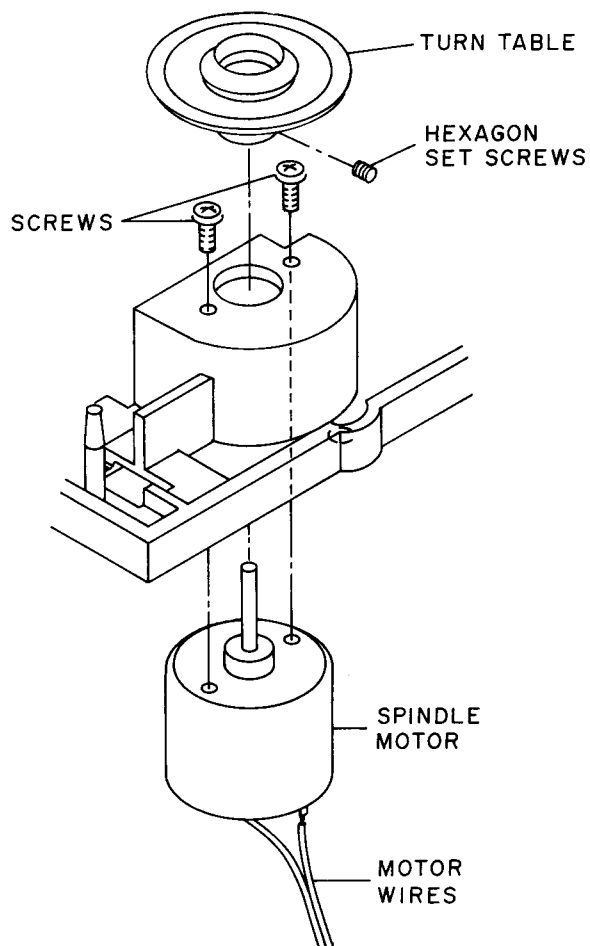
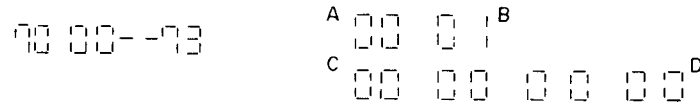

Fig. 5-1

VI. SERVO ADJUSTMENT

HOW TO USING THE TEST MODE

- While Power is on, short the pin ① and ② of the connector P3 on the DIGITAL PCB, a while, then machine set to the test mode.
- While in the test mode, following indication is indicated on the display.



- A: Indicate the track number where the pick-up is locating.
- B: Indicate the test mode number.
- C: Indicate the individual time of the track.
- D: Indicate the total time.

* Indication A, C, and D are indicated only in the test mode 08, and 09.

- While in the test mode, the test mode can be advanced by pressing the **OPEN/CLOSE** button. At this time, indication B is indicated test mode number on the display.

OPERATION	INDICATION B	FUNCTION
1st push of OPEN/CLOSE Button	00 01	Pick-up lens down
2nd push of OPEN/CLOSE Button	00 02	Focus Search end
3rd push of OPEN/CLOSE Button	00 03	Focus Gain down
4th push of OPEN/CLOSE Button	00 04	CLV Kick
5th push of OPEN/CLOSE Button	00 05	CLV rough Servo "ON"
6th push of OPEN/CLOSE Button	00 06	Tracking Servo "ON"
7th push of OPEN/CLOSE Button	00 07	CLV & Sled Servo "ON"
8th push of OPEN/CLOSE Button	00 08	FOCUS & Tracking Gain normal, mute "OFF" Anti Shock "OFF", Emphasis "OFF".
9th push of OPEN/CLOSE Button	00 09	FOCUS & Tracking Gain normal, mute "OFF" Anti Shock "ON", Emphasis "OFF".
10th push of OPEN/CLOSE Button	Normal mode	Normal search

- The sled can be carrying forcedly by **FF** or **FR** button in the test modes 08 and 09.
- When push the **OPEN/CLOSE** button once from test mode 09, the machine releases from the test mode.
* At this time, pins 1 and 2 of P3 to still shorted, the machine repeat the test mode 01 to 09 cyclically.

STEP	ADJUSTMENT ITEM
1.	Test Disc
2.	Mode
3.	Test Point & Adj. Part
4.	Result & Remarks

ADJ. Part
Test Point

5	DC BALANCE
1.	TEST DISC TYPE III (AT-711881)
2.	PLAY
3.	• Connect a DIGITAL VOLTMETER to LINE OUT. • VR2 (L-CH) & VR2b (R-CH) on the ANALOG PCB.
4.	• Play back track No. 23 of the test disc. • $0V \pm 0.1 mV$

6	PLL Frequency
1.	TEST DISC TYPE III (AT-711881)
2.	PLAY
3.	• Connect a Frequency counter between TP1 and GND. • VR1
4.	Slightly turn the VR1 to clockwise so that the sound disappear, (PLL unlocked) then turn the VR1 counterclockwise and read the frequency on the frequency counter at the point sound appeared (f1) again, turn the VR1 to counterclockwise so that the sound disappear then slightly turn the VR1 clockwise and read the frequency on the frequency counter at the point sound appeared (f2). Set the VR1 so that the frequency on the frequency counter is $\frac{f1 + f2}{2} = 7350 Hz$

7	Distortion Factor
1.	TEST DISC TYPE III (AT-711881)
2.	PLAY (Track No.1)
3.	• Connect the distortion meter to the LINE OUT. • VR1 and VR1 (b)
4.	Minimum distortion

4	TRACKING SERVO CONTROL GAIN
1.	TEST DISC TYPE III (AT-711881)
2.	TEST MODE 8
3.	• Connect an oscilloscope between TP9 and GND. • VR3
4.	600 mV to 1Vp-p

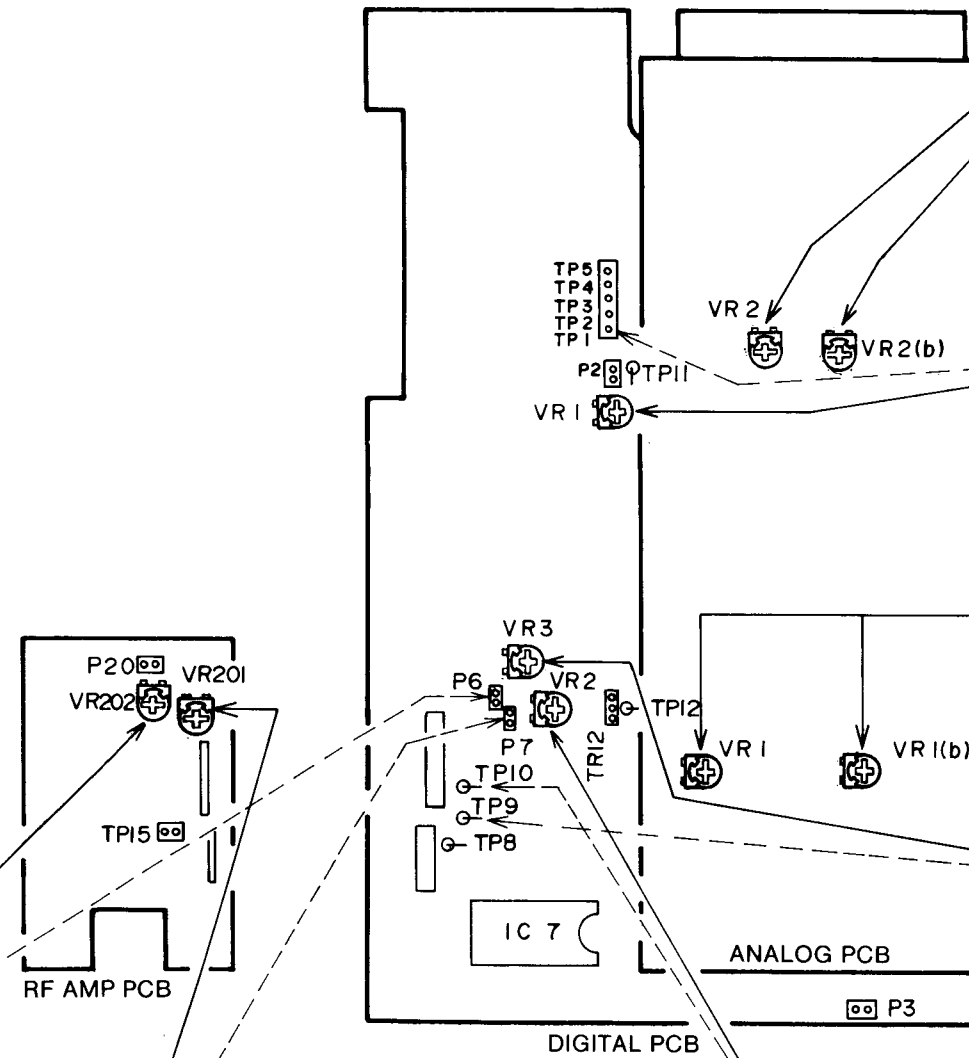
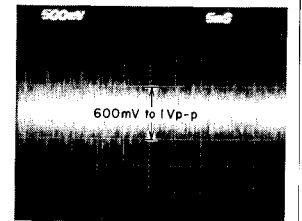

2	E-F BALANCE
1.	TEST DISC TYPE III (AT-711881)
2.	TEST MODE 05
3.	• Connect an oscilloscope (DC Range) between P6 and GND. • VR202
4.	A = B (DC Range)

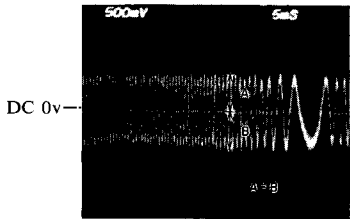

1	FOCUS SERVO OFF-SET
1.	TEST DISC TYPE III (AT-711881)
2.	TEST MODE 02
3.	• Connect a DIGITAL VOLTMETER between P7 and TP12 (GND) • VR201
4.	• Measure the voltage (A) between P7 and TP12 (GND) at the test mode 02, then turn the power is OFF and ON again, Measure the voltage (B) between P7 and TP12 (GND) and adjust VR201 so that the voltage (B) equal voltage (A).

3	FOCUS SERVO CONTROL GAIN
1.	TEST DISC TYPE III (AT-711881)
2.	TEST MODE 08
3.	• Connect an oscilloscope between TP10 and GND. • VR2
4.	1.0 to 1.4 Vp-p

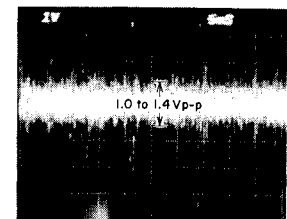

VII. PARTS LIST

ATTENTION

1. When placing an order for parts, be sure to list Part No., Model No. and the description of each part. Otherwise, the non-delivery of the part or the delivery of a wrong part may result.
2. Please make sure that Part No. is correct when ordering.
If not, a part different from the one you ordered may be delivered.
3. Since the parts shown in Parts List of Preliminary Service Manual may have been the subject of changes, please use this Parts List for all future reference.

HOW TO USE THIS PARTS LIST

1. This Parts List lists those parts which are considered necessary for repairs. Other common parts, such as resistors and capacitors, are listed in the "Common List for Service Parts" from which these parts should be selected and stocked.
2. The Recommended Spare Parts List shows those parts in the Parts List which are considered particularly important for service.
3. Parts not shown in the Parts List and "Common List for Service Parts" will not in principle be supplied.
4. How to read the Parts List.

a) Mechanism Block

b) PC Board

2. HEAD BASE BLOCK

REF. NO.	PART NO.	DESCRIPTION
2-1x	BH-T2023A320A	HEAD BASE BLOCK
2-2	HP-H2206A010A	HEAD R/P PR4-8FU C
2-3	ZS-477876	PAN20x03STL CMT
2-4	ZS-536488	BID20x08STL CMT
2-5	ZG-402895	SP CS ANGLE ADJUST

- SP (Service Parts) Classification
- A small "x" indicates that this part is not shown in the Photo or Illustration.
- This number corresponds with the individual parts index number in that figure.
- This number corresponds with the Figure Number.

6. MAIN PC BOARD

REF. NO.	PART NO.	DESCRIPTION
6-IC1	EI-324536	IC HD14049BP
6-IC2	EI-336801	IC MB8841-564M
6-C1A	EC-338399	C MMY V 223M 250AC [U,E,B,S]
6-C1B	EC-350949	C MMY V 223M 250DC [J]
6-C1C	EC-338397	C MMY V 223M 125AC [C,A]
6-X1	EI-318384	OSC X'TAL NC-18C

- Symbols for primary destination
- [A]: AAL(U.S.A.) [S]: SAA(Australia)
- [B]: BEAB(England) [U]: U/T(Universal Area)
- [C]: CSA(Canada) [V]: VDE(W. Germany)
- [E]: CEE(Europe) [Y]: Custom Version
- [J]: JPN(Japan)
- SP (Service Parts) Classification
- These reference symbols correspond with component symbols in the Schematic Diagrams.

The available PC Board Blocks are listed separately.

5. When Part No. is known, Parts Index at end of Parts List can be used to locate where that part is shown in Parts List by its Reference No. listed at right of Part No.

WARNING

△ (*) INDICATES SAFETY CRITICAL COMPONENTS. FOR CONTINUED SAFETY, REPLACE SAFETY CRITICAL COMPONENTS ONLY WITH MANUFACTURE'S RECOMMENDED PARTS.

AVERTISSEMENT

△ (*) IL INDIQUE LES COMPOSANTS CRITIQUES DE SÉCURITÉ. POUR MAINTENIR LE DEGRÉ DE SÉCURITÉ DE L'APPAREIL, NE REMPLACER QUE DES PIÈCES RECOMMANDÉES PAR LE FABRICANT.

1. RECOMMENDED SPARE PARTS

Ref. No.	Part No.	Description	Ref. No.	Part No.	Description
1	BM-381926J	MOTOR RF-310T-11400 D/V 9V [M902][SPINDEL MOTOR]	59	ES-377848	SW SLIDE SSSU01002A [TIMER SW]
2	BM-328441	MOTOR RF-510T(12620) [M903][LOADING MOTOR]	60	ES-377867	SW SLIDE SSSU12002A [DIGITAL OUT ON/OFF]
3	*BO-377825	PICK UP KSS-151A	61	*ES-349464	SW SLIDE 00120319 01-2 [U]
4	*BT-377890J1	TRANS POW P2027(B,S) [B]	62	ES-349474	SW TACT SKHHAM0004A
5	*BT-377888J1	TRANS POW P2027(C,A) [C,A]	63	ET-371075	TR DTA124XS
6	*BT-377889J1	TRANS POW P2027(E,V) [E,V]	64	ET-370634	TR DTA143XS
7	*BT-377885J1	TRANS POW P2027(U) [U]	65	ET-373485	TR DTC123JS
8	BT-368261	TRANS PULSE TC-1027-04	66	ET-373392	TR DTC124XS
9	ED-356424	D LED BG5525S GREEN	67	*ET-348829	TR 2SA1209 S,T
10	ED-360409	D PHOTO PN323B	68	ET-353899	TR 2SA1317 S,T,U
11	ED-301911	D SILICON H DS448	69	ET-349718	TR 2SA1392 S,T
12	ED-344280	D SILICON H GMA-01-FY2 F05	70	ET-352726	TR 2SA1392 T,U
13	*ED-379184	D SILICON HRP22 F10 50/1.0A	71	ET-347026	TR 2SB507HP E,F
14	*ED-330622	D SILICON 1SR35-100VL 100/1.0A	72	ET-322598	TR 2SB632K E,F
15	ED-367576	D ZENER H HZS5.6J B2 F05	73	*ET-318237	TR 2SB764 E,F
16	ED-346558	D ZENER H HZ12L B1	74	ET-356817	TR 2SB891 Q,R
17	ED-346568	D ZENER H HZ16L 3	75	*ET-348831	TR 2SC2911 S,T
18	ED-346591	D ZENER H HZ36L 3	76	ET-360067	TR 2SC3330 T,U F05
19	ED-330962	D ZENER H HZ4 C1	77	*ET-349081	TR 2SC3383 S,T
20	ED-306010	D ZENER H HZ6 A2	78	ET-354083	TR 2SD1189 Q,R
21	ED-343410	D ZENER H HZ6L A1	79	ET-365456	TR 2SD1468S Q,R,S
22	ED-346526	D ZENER H HZ6L B1	80	ET-370809	TR 2SD1468S R,S
23	ED-306013	D ZENER H HZ7 C1	81	ET-344176	TR 2SD313HP F
24	ED-346545	D ZENER H HZ9L C2	82	*ET-310148	TR 2SD612K E,F
25	ED-377861	DETECTOR 6N137 (YHP)	83	EV-378744J	VR ROTARY RK16312A0 B104X2 [HEADPHONE LEVEL]
26	*EF-359342	FUSE BET T 250V 400MA [B]	84	MB-377660	BELT(A)
27	*EF-358641	FUSE BET T 250V 800MA [B]	85	MB-377914	BELT(D)
28	*EF-668474	FUSE SEMKO T 250V 400MA [E,V]	86	MZ-352143	GEAR WORM
29	*EF-258344	FUSE SEMKO T 250V 800MA [E,V]	87	MZ-377667	GEAR WORM WHEEL
30	*EF-309392	FUSE TSC 125V 1.25A [C,A]			
31	*EF-305703	FUSE TSC 125V 630MA [C,A]			
32	EH-380185J	FILTER EMI ZBF503S-01			
33	EI-377857	IC BA6247N			
34	EI-368608	IC CXA1081			
35	EI-368609	IC CXA1082A			
36	EI-368610	IC CXD1135Q			
37	EI-362975	IC HD6805S1PB18			
38	EI-336794	IC LB1240			
39	EI-368611	IC LC3517AS-15			
40	EI-377767	IC LC6568H-3425 P2026 COSTOM			
41	*EI-377860	IC M5F7805			
42	EI-380319J	IC M50747-433SP AKAI-3 CUSTOM			
43	EI-349719	IC M5218P			
44	EI-362588	IC M5238P			
45	EI-377191	IC NJM5532D-D			
46	EI-368612	IC PCM56P			
47	EI-360040	IC TC74HCU04P			
48	EI-360039	IC TC74HC08P			
49	EI-367271	IC UPC1490HA			
50	*EI-377246	IC UPC79M05HF			
51	EI-377855	IC YM3404B			
52	EI-349372	OSC CE CSA4.00MG 4MHZ			
53	EI-374176	OSC X'TAL AT-51 16.9344MHZ			
54	EM-377851	IND FL 14-BT-14GK CHARACTER			
55	EQ-348929	RELAY SIG G5A-237P 2TR 12V			
56	ES-344253	SW LEAF MSW-1418J 01-1 NO [OPEN SW]			
57	ES-344257	SW LEAF MSW-1418L 01-1 NO [CLAMP DOWN SW]			
58	*ES-377828J	SW PUSH ESB8296V 01-1 [POWER]			

MECHA BLOCK

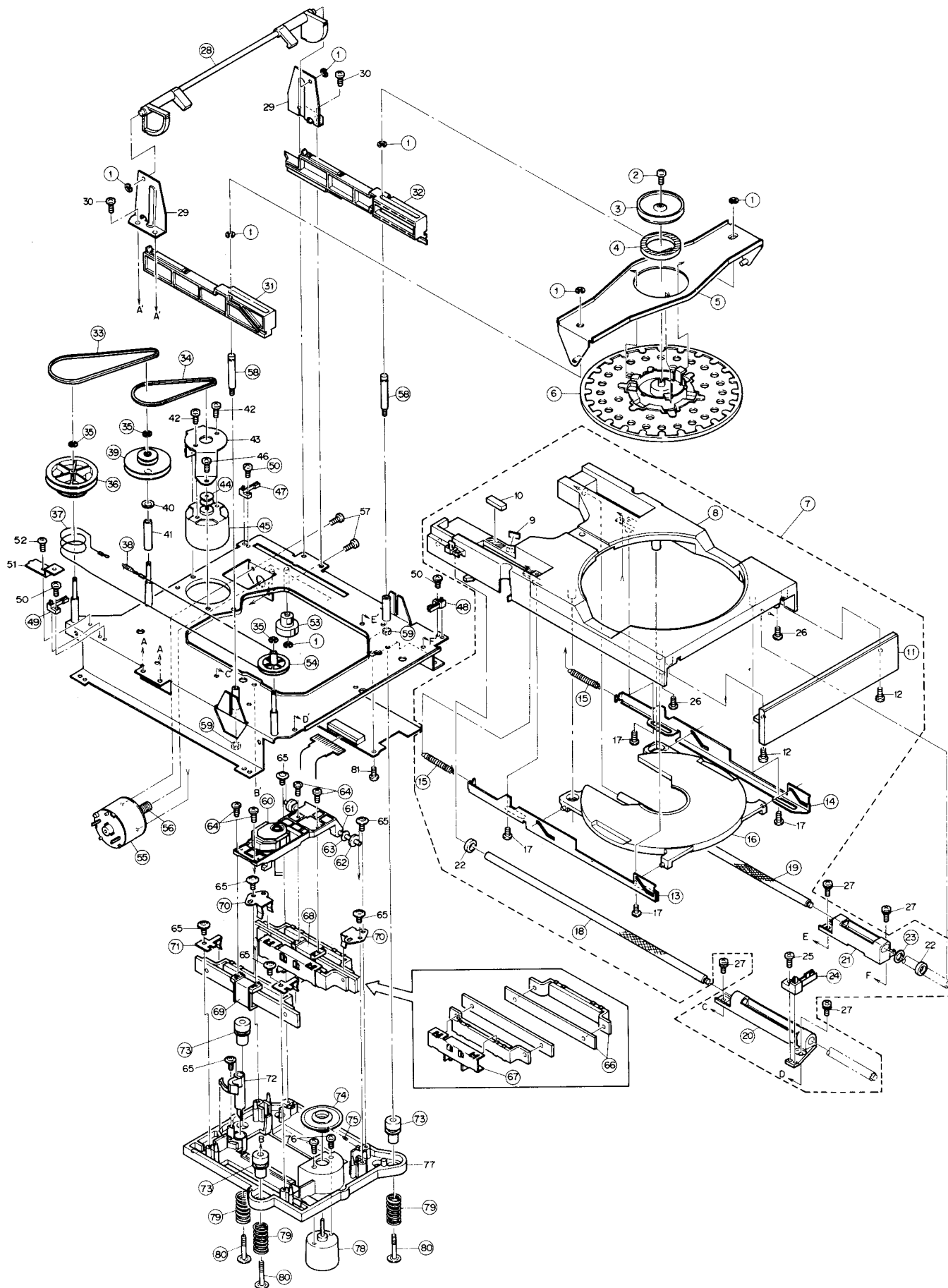

2. MECHA BLOCK

Ref. No.	Part No.	Description
1	ZW-270101	RING E 300SUP CMT
2	ZS-355149	PT BID26X05STL CMT
3	MZ-377671	PLATE MAGNET
4	MZ-377826	MAGNET FM 30X17X5.2
5	SC-B377673	HOLDER STABILIZER PART
7	SC-P2027A060A	DISC TREY BLK CD-73
8	SC-377907	DISK TRAY CD-73
11	SP-377742	PANEL TRAY B
12	ZS-351886	PT BR30X10STL BNI
13	ML-377647A	LEVER ELEVATION(L)
14	ML-380551J1	LEVER ELEVATION(R)
15	ZG-358111	SP T5-03.2/0.29-22.4 T5-065
16	SZ-377677	HOLDER DISK
17	ZS-350934	PT BR30X08STL BNI
18	MS-377649A	SHAFT TRAY(L)
19	MS-380550J1	SHAFT TRAY(R)
20	ML-377652	HOLDER SHAFT(L)
21	ML-377653	HOLDER SHAFT(R)
23	ZW-376391	PW61X100X013PSL
24	ES-344253	SW LEAF MSW-1418J 01-1 NO [OPEN SW]
25	ZS-377928	PT BID20X08STL CMT
26	ZS-378512J	PT BR30X08STL BNI C080
27	ZS-608321	PAN30X06STL CMT PW080
28	ML-377668	LEVER OUTSERT
30	ZS-355511	BID30X06STL BNI
31	SC-377654	RACK GEAR(L)
32	SC-377655	RACK GEAR(R)
33	MB-377660	BELT(A)
34	MB-377914	BELT(D)
35	ZW-270088	RING E190SUP CMT
36	MR-377657	PULLEY ROPE MAIN
37	SZ-377791	JAINT WIRE
38	ZG-377680	SP PULL ROPE
39	BR-377659	PULLEY BELT
40	ZW-378725J	PW30X060X010PBR
42	ZS-377930	BID26X03STL BNI
44	MR-345182	PULLEY MOTOR
45	BM-328441	MOTOR RF-510T(12620) [M903][LOADING MOTOR]
46	ZS-355511	BID30X06STL BNI
47	ES-344257	SW LEAF MSW-1418L 01-1 NO [CLAMP DOWN SW]
48	ES-344257	SW LEAF MSW-1418L 01-1 NO [CLAMP UP SW]
49	ES-344257	SW LEAF MSW-1418L 01-1 NO [CLOSE SW]
50	ZS-376361	ST BID20X06STL BNI
52	ZS-345272	ST BR30X06STL BNI
53	MZ-377667	GEAR WORM WHEEL
54	MR-377658	PULLEY ROPE SUB
55	BM-328441	MOTOR RF-510T(12620) [M904][CLAMP MOTOR]
56	MZ-352143	GEAR WORM
57	ZS-377930	BID26X03STL BNI
58	MZ-377656	PROP 9 M.SCREW RACK GEAR
59	ZW-516993	N30STL CMT 1
60	*BO-377825	PICK UP KSS-151A
61	MS-375730	SHAFT P.U
62	MB-375732	CUSHION P.U
63	ZW-378397	PW30X080X013PSL
64	ZS-378680J	BT PAN17X04STL CMT
65	ZS-377926	ST BR30X05STL BNI C080
66	BV-B375720	MAGNET PART
68	EO-B375723	COIL F PART
69	EO-B375725	COIL V PART
70	MZ-375728	HOLDER YOKE F
71	MZ-375729	HOLDER YOKE V
73	MB-375733	CUSHION RUBBER
74	MZ-B377909	TURN TABLE PART
75	ZS-378683J	6SET26X030SCM PKR WP
76	ZS-537085	BID20X05STL CMT
78	BM-381926J	MOTOR RF-310T-11400 D/V 9V [M902][SPINDEL MOTOR]
79	ZG-377913	SP PUSH CUSHION
80	ZS-377679	SCREW GRADUATED(B)
81	ZS-358803	ST BR30X08STL BNI C080

3. P.C BOARD BLOCK

Ref. No.	Part No.	Description
1A	BA-P2026A120C	PC(##) DIGITAL BLK CD-73(U) [U]
1B	BA-P2026A120D	PC(##) DIGITAL BLK CD-73(E) [E,V,B]
1C	BA-P2026A120F	PC(##) DIGITAL BLK CD-73(C) [C,A]
2A	BA-P2027A040A	PC ANALOG BLK CD-73(U) [U]
2B	BA-P2027A040B	PC ANALOG BLK CD-73(E) [C,A,E,V,B]
3	BA-P2026A150B	PC(##)OPERACIÓN BLK CD-73

4. DIGITAL P.C BOARD

Ref. No.	Part No.	Description
D1	ED-346545	D ZENER H HZ9L C2
D2	*ED-330622	D SILICON 1SR35-100VL 100/1.0A
D3	ED-301911	D SILICON H DS448
D4	ED-344280	D SILICON H GMA-01-FY2 F05
D5	ED-344280	D SILICON H GMA-01-FY2 F05
D6	ED-330962	D ZENER H HZ4 C1
D7	ED-330962	D ZENER H HZ4 C1
D8	ED-301911	D SILICON H DS448
D9	ED-346591	D ZENER H HZ36L 3
D10	*ED-330622	D SILICON 1SR35-100VL 100/1.0A
D11	*ED-330622	D SILICON 1SR35-100VL 100/1.0A
D12	*ED-330622	D SILICON 1SR35-100VL 100/1.0A
D13	*ED-330622	D SILICON 1SR35-100VL 100/1.0A
D14	ED-344280	D SILICON H GMA-01-FY2 F05
D15	ED-344280	D SILICON H GMA-01-FY2 F05
D16	ED-367576	D ZENER H HZS5.6J B2 F05
D17	*ED-330622	D SILICON 1SR35-100VL 100/1.0A
D18	*ED-330622	D SILICON 1SR35-100VL 100/1.0A
D19	ED-306010	D ZENER H HZ6 A2
D20	ED-301911	D SILICON H DS448
D21	ED-306013	D ZENER H HZ7 C1
D22	ED-306013	D ZENER H HZ7 C1
D23	*ED-330622	D SILICON 1SR35-100VL 100/1.0A
D24	*ED-330622	D SILICON 1SR35-100VL 100/1.0A
D25	*ED-330622	D SILICON 1SR35-100VL 100/1.0A
FL901	EH-380185J	FILTER EMI ZBF503S-01
IB1	EH-352061	COMP R RKC1/8B8D 104J
IB2	EH-378669J	COMP R RKC5DS 104J
IB3	EH-364919	COMP R RKC8BS 473J
IB4	ER-371844	COMP R RKC3BS 472J
IB5	EH-348116	COMP R RKC1/8B3 473J
IB6	EH-348116	COMP R RKC1/8B3 473J
IC1	EI-368610	IC CXD1135Q
IC2	EI-368611	IC LC3517AS-15
IC3	EI-377855	IC YM3404B
IC4	EI-360040	IC TC74HCU04P
IC5	EI-360039	IC TC74HC08P
IC6	EI-362975	IC HD6805S1PB18
IC7	EI-380319J	IC M50747-433SP AKAI-3 CUSTOM
IC8	EI-377857	IC BA6247N
IC9	EI-368609	IC CXA1082A
IC10	EI-349719	IC M5218P
IC11	EI-349719	IC M5218P
IC12	*EI-377860	IC M5F7805
IC13	*EI-377246	IC UPC79M05HF
J11	EJ-368260	PIN J RA B TYPE GP WO/SW 1P [DIGITAL OUT]
L1	EO-345913	COIL FIX 1 LAL03KH 100K
P1	EJ-374191	SOCKET OPTICAL TOTX172 [OPTICAL OUT]
PT1	BT-368261	TRANS PULSE TC-1027-04
R71	*ER-322332	R CB H S10 FS RDS 1/4W 8R2J
SW1	ES-377867	SW SLIDE SSSU12002A [DIGITAL OUT ON/OFF]

Ref. No.	Part No.	Description
TR1	ET-360067	TR 2SC3330 T,U F05
TR2	ET-365456	TR 2SD1468S Q,R,S
TR3	ET-360067	TR 2SC3330 T,U F05
TR4	ET-360067	TR 2SC3330 T,U F05
TR5	ET-360067	TR 2SC3330 T,U F05
TR6	ET-354083	TR 2SD1189 Q,R
TR7	ET-356817	TR 2SB891 Q,R
TR8	ET-354083	TR 2SD1189 Q,R
TR9	ET-356817	TR 2SB891 Q,R
TR10	ET-360067	TR 2SC3330 T,U F05
TR11	ET-352726	TR 2SA1392 T,U
TR12	ET-360067	TR 2SC3330 T,U F05
TR13	ET-344176	TR 2SD313HP F
TR14	ET-322598	TR 2SB632K E,F
TR15	ET-354083	TR 2SD1189 Q,R
TR16	ET-347026	TR 2SB507HP E,F
TR17	ET-360067	TR 2SC3330 T,U F05
TR18	ET-353899	TR 2SA1317 S,T,U
TR19	*ET-349081	TR 2SC3383 S,T
TR20	*ET-318237	TR 2SB764 E,F
TR21	ET-360067	TR 2SC3330 T,U F05
VR1	EV-380682J	R S-FIX H KVSF687A 0.30W 152
VR2	EV-358829	R S-FIX H RH0615C 0.10W 223
VR3	EV-358829	R S-FIX H RH0615C 0.10W 223
X1	EI-374176	OSC X'TAL AT-51 16.9344MHZ
X2	EI-349372	OSC CE CSA4.00MG 4MHZ
F1A	*EF-309392	FUSE TSC 125V 1.25A [C,A]
F2A	*EF-309392	FUSE TSC 125V 1.25A [C,A]
F1B	*EF-258344	FUSE SEMKO T 250V 800MA [E,V]
F2B	*EF-258344	FUSE SEMKO T 250V 800MA [E,V]
F1C	*EF-358641	FUSE BET T 250V 800MA [B]
F2C	*EF-358641	FUSE BET T 250V 800MA [B]

5. RF AMP P.C BOARD

Ref. No.	Part No.	Description
IC201	EI-368608	IC CXA1081
TR201	ET-349718	TR 2SA1392 S,T
VR201	EV-356577	R S-FIX H RH0615C 0.10W 103
VR202	EV-358829	R S-FIX H RH0615C 0.10W 223

6. ANALOG P.C BOARD

Ref. No.	Part No.	Description
D1	ED-301911	D SILICON H DS448
D2	ED-301911	D SILICON H DS448
D3	ED-343410	D ZENER H HZ6L A1
D4	ED-301911	D SILICON H DS448
D5	ED-346558	D ZENER H HZ12L B1
D6	ED-301911	D SILICON H DS448
D7	*ED-330622	D SILICON 1SR35-100VL 100/1.0A
D8	*ED-330622	D SILICON 1SR35-100VL 100/1.0A
D9	*ED-379184	D SILICON HRP22 F10 50/1.0A
D10	*ED-379184	D SILICON HRP22 F10 50/1.0A
D11	*ED-379184	D SILICON HRP22 F10 50/1.0A
D12	*ED-379184	D SILICON HRP22 F10 50/1.0A
D13	ED-346558	D ZENER H HZ12L B1
D14	ED-346558	D ZENER H HZ12L B1

Ref. No.	Part No.	Description
D15	ED-346568	D ZENER H HZ16L 3
D16	ED-346568	D ZENER H HZ16L 3
D17	ED-356424	D LED BG5525S GREEN
D18	ED-356424	D LED BG5525S GREEN
D19	ED-346526	D ZENER H HZ6L B1
D20	ED-346526	D ZENER H HZ6L B1
D21	ED-301911	D SILICON H DS448
FL1	EH-380185J	FILTER EMI ZBF503S-01
FL2	EH-380185J	FILTER EMI ZBF503S-01
FL3	EH-380185J	FILTER EMI ZBF503S-01
IC1	EI-360040	IC TC74HCU04P
IC2	ED-377861	DETECTOR 6N137 (YHP)
IC3	EI-368612	IC PCM56P
IC4	EI-377191	IC NJM5532D-D
IC5	EI-362588	IC M5238P
L1	EO-377922	COIL FIX 2 *P2027
P3	EJ-368063	PIN J YKC21-0210 P 2P GP [LINE OUT]
RL1	EQ-348929	RELAY SIG G5A-237P 2TR 12V
RL2	EQ-348929	RELAY SIG G5A-237P 2TR 12V
R32	ER-378672J	R OMF H S10 FS 1/2W 181J
R33	ER-378672J	R OMF H S10 FS 1/2W 181J
TR1	ET-373485	TR DTC123JS
TR2	ET-352726	TR 2SA1392 T,U
TR3	ET-349081	TR 2SC3383 S,T
TR4	ET-373392	TR DTC124XS
TR5	ET-371075	TR DTA124XS
TR6	ET-371075	TR DTA124XS
TR7	ET-370634	TR DTA143XS
TR8	*ET-349081	TR 2SC3383 S,T
TR9	ET-352726	TR 2SA1392 T,U
TR10	*ET-348831	TR 2SC2911 S,T
TR11	*ET-348829	TR 2SA1209 S,T
TR12	*ET-310148	TR 2SD612K E,F
TR13	*ET-352726	TR 2SA1392 T,U
VR1	EV-357619	R S-FIX H RH0615C 0.10W 104
VR2	EV-356582	R S-FIX H RH0615C 0.10W 473
F3A	*EF-305703	FUSE TSC 125V 630MA [C,A]
F3B	*EF-305703	FUSE TSC 125V 630MA [C,A]
F3B	*EF-668474	FUSE SEMKO T 250V 400MA [E,V]
F4B	*EF-668474	FUSE SEMKO T 250V 400MA [E,V]
F3C	*EF-359342	FUSE BET T 250V 400MA [B]
F4C	*EF-359342	FUSE BET T 250V 400MA [B]

7. OPERATION P.C BOARD

Ref. No.	Part No.	Description
IC1	EI-377767	IC LC6568H-3425 P2026 CUSTOM
IC2	EI-336794	IC LB1240
IC3	EI-336794	IC LB1240
IC4	EI-336794	IC LB1240
IC5	EI-336794	IC LB1240
IN1	EM-377851	IND FL 14-BT-14GK CHARAC TER
TS1	ES-349474	SW TACT SKHHAM004A
TS2	ES-349474	SW TACT SKHHAM004A
TS3	ES-349474	SW TACT SKHHAM004A
TS4	ES-349474	SW TACT SKHHAM004A
TS5	ES-349474	SW TACT SKHHAM004A
TS6	ES-349474	SW TACT SKHHAM004A
TS7	ES-349474	SW TACT SKHHAM004A
TS8	ES-349474	SW TACT SKHHAM004A
TS9	ES-349474	SW TACT SKHHAM004A
TS10	ES-349474	SW TACT SKHHAM004A
TS11	ES-349474	SW TACT SKHHAM004A

Ref. No.	Part No.	Description
TS12	ES-349474	SW TACT SKHHAM004A
TS13	ES-349474	SW TACT SKHHAM004A
TS14	ES-349474	SW TACT SKHHAM004A
TS15	ES-349474	SW TACT SKHHAM004A
TS16	ES-349474	SW TACT SKHHAM004A
TS17	ES-349474	SW TACT SKHHAM004A
TS18	ES-349474	SW TACT SKHHAM004A
TS19	ES-349474	SW TACT SKHHAM004A
TS20	ES-349474	SW TACT SKHHAM004A
TS21	ES-349474	SW TACT SKHHAM004A
TS22	ES-349474	SW TACT SKHHAM004A
TS23	ES-349474	SW TACT SKHHAM004A
TS24	ES-349474	SW TACT SKHHAM004A
TS25	ES-349474	SW TACT SKHHAM004A
TS26	ES-349474	SW TACT SKHHAM004A
TS27	ES-349474	SW TACT SKHHAM004A
TS28	ES-349474	SW TACT SKHHAM004A
TS29	ES-349474	SW TACT SKHHAM004A
TS30	ES-349474	SW TACT SKHHAM004A
TS31	ES-349474	SW TACT SKHHAM004A

11. POWER SUPPLY P.C BOARD

Ref. No.	Part No.	Description
C1A	*EC-320548	C CE V F 103Z 250AC [U]
C1B	*EC-338411	C CE V FZ 103P 400AC [C,A]
C1C	*EC-367928	C MMY V XE 103M 250AC [E,V,B]
C2A	*EC-320548	C CE V F 103Z 250AC [U]
C2B	*EC-338411	C CE V FZ 103P 400AC [C,A,E,V,B]
C3A	*EC-320548	C CE V F 103Z 250AC [U]
C3B	*EC-338411	C CE V FZ 103P 400AC [C,A,E,V,B]
L1	*EO-338409	COIL LF FKOB160MH02 250UH
SW1	*ES-377828J	SW PUSH ESB8296V 01-1 [POWER]
VS1	*ES-349464	SW SLIDE 00120319 01-2 [U]

8. SENSOR C P.C BOARD

Ref. No.	Part No.	Description
D1	ED-360409	D PHOTO PN323B
IC1	EI-367271	IC UPC1490HA

9. HEADPHONE P.C BOARD

Ref. No.	Part No.	Description
FL101	EH-380185J	FILTER EMI ZBF503S-01
IC101	EI-362588	IC M5238P
J101	EJ-380560J	PHONE J 3P LG1212-0103 GP 6.3 [HEADPHONE]
TR101	ET-370809	TR 2SD1468S R.S
VR101	EV-378744J	VR ROTARY RK16312A0 B104X2 [HEADPHONE LEVEL]

10. TIMER SW P.C BOARD

Ref. No.	Part No.	Description
SW101	ES-377848	SW SLIDE SSSU01002A [TIMER SW]

ASSEMBLY BLOCK

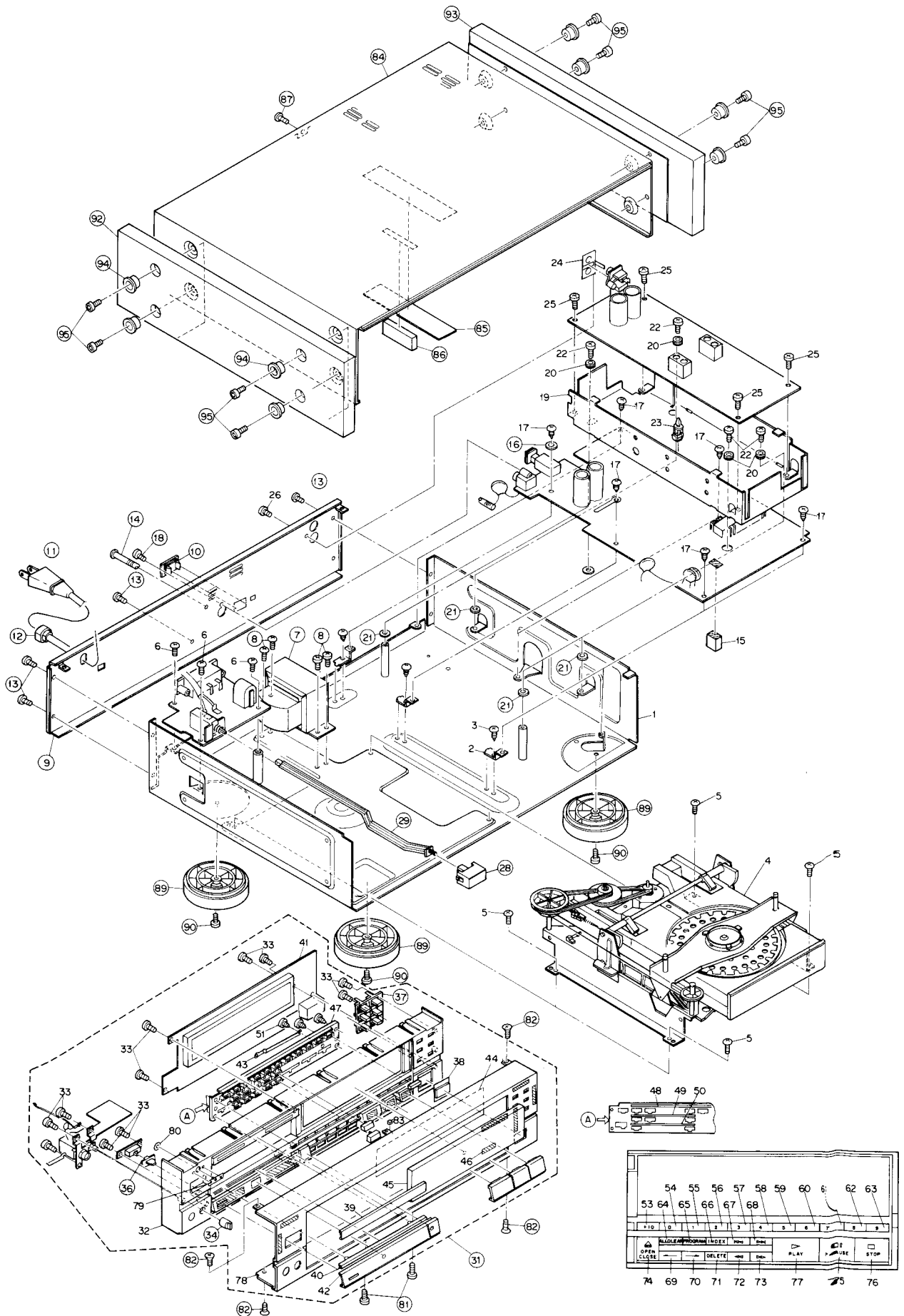

PARTS LIST

12. ASSEMBLY BLOCK

Ref. No.	Part No.	Description	Ref. No.	Part No.	Description
3	ZS-325495	T2BR30X06STL CMT	72	SK-B377705D	KNOB EDIT(2) (F,F) B PART
5	ZS-345272	ST BR30X06STL BNI	73	SK-B377705E	KNOB EDIT(2) (F,B) B PART
6	ZS-320906	ST BR30X06STL CMT	74	SK-377709	KNOB OPEN B
7A	*BT-377885J1	TRANS POW P2027(U) [U]	75	SK-377713A	KNOB PAUSE B
7B	*BT-377888J1	TRANS POW P2027(C,A) [C,A]	76	SK-377713B	KNOB STOP B
7C	*BT-377889J1	TRANS POW P2027(E,V) [E,V]	77	SK-377715	KNOB PLAY
7D	*BT-377890J1	TRANS POW P2027(B,S) [B]	79	SM-365756C	NAME PLATE AKA(2)
8	ZS-313796	ST BID40X06STL CMT	80	ZW-653163	RING CS 280STL PKR
9A	SP-380722J2	PANEL REAR CD-73(U) [U]	81	ZS-376523	ST BID30X06STL BNI EARTH LOCK
9B	SP-380724J2	PANEL REAR CD-73(C,A) [C,A]	82	ZS-342209	ST CTS30X06STL BNI
9C	SP-380725J2	PANEL REAR CD-73(E) [E]	84	SP-377891	COVER UPPER B
9D	SP-380726J2	PANEL REAR CD-73(V) [V]	87	ZS-353355	CT BR30X06STL BZN PROJECTION
9E	SP-380727J2	PANEL REAR CD-73(B,S) [B]	89	SA-B368687	FOOT ROUND SHAPED PART
10	SE-375348	ESLUTCHEON	90	ZS-300517	ST BID40X12STL BNI
11A	*EW-363659	AC CORD 200 0129AVFF B070 A U [U]	91	MZ-553948	WIRE BAND F-100
11B	*EW-363634	AC CORD200 0238ASPT2 B070 A UC [C,A]	92	SP-377747	SIDE BOARD(L)
11C	*EW-363672	AC CORD 200 0364 LCFL B070 A EV [E,V]	93	SP-377748	SIDE BOARD(R)
11D	*EW-363684	AC CORD 200 LCFL B070 A B [B]	94	ZW-376292	WASHER SIDE BOARD
12	*EZ-302906	STRAIN RELIEF SR-6N-4	95	ZS-376293	SCREW SIDE BOARD
13	ZS-353355	CT BR30X06STL BZN PROJECTION			
14	ZS-332468	T2BR30X20STL NI3 GUIDE			
16	ZW-259503	PW31X080X050NYL			
17	ZS-378785J	T2BR30X06STL COP			
18	ZS-351204	PT BR30X06STL BNI			
21	ZW-378813J	PW51X100X050PBR W/WF TAPE			
22	ZS-378525J	DT PAN30X09STL COP C080 L = 4			
25	ZS-377153	ST BID30X06STL COP			
26	ZS-351204	PT BR30X06STL BNI			
27	ZS-332468	T2BR30X20STL NI3 GUIDE			
28	SK-373236B	KNOB POWER-B			
29	ML-377689	JOINT SW			
30	EZ-323793	CORD RETAINER 32X41			
31	BD-P2026A140C	PANEL FRONT BLK CD-73-B			
33	ZS-332009	PT BR30X06STL CMT			
34	SK-377733	KNOB VOL B			
35	EZ-323793	CORD RETAINER 32X41			
36	SK-377734	KNOB TIMER B			
37	SK-377735	KNOB REPEAT B			
41	ZW-316800	EL26BRS TIN 5L			
43	ZW-325519	EL30BRS TIN 8L BEND			
44	SE-377737	FILTER DISPLAY			
52	ZS-336613	PT PAN26X06STL CMT			
53	SK-B377701A	KNOB PROGRAM(10+) B PART			
54	SK-B377701B	KNOB PROGRAM(0) B PART			
55	SK-B377701C	KNOB PROGRAM(1) B PART			
56	SK-B377701D	KNOB PROGRAM(2) B PART			
57	SK-B377701E	KNOB PROGRAM(3) B PART			
58	SK-B377701F	KNOB PROGRAM(4) B PART			
59	SK-B377701G	KNOB PROGRAM(5) B PART			
60	SK-B377701H	KNOB PROGRAM(6) B PART			
61	SK-B377701J	KNOB PROGRAM(7) B PART			
62	SK-B377701K	KNOB PROGRAM(8) B PART			
63	SK-B377701L	KNOB PROGRAM(9) B PART			
64	SK-B377703A	KNOB EDIT(1)(ALL CLEAR) B PART			
65	SK-B377703B	KNOB EDIT(1) (PROGRAM) B PART			
66	SK-B377703C	KNOB EDIT(1) (INDEX) B PART			
67	SK-B377703D	KNOB EDIT(1) (B,S) B PART			
68	SK-B377703E	KNOB EDIT(1) (F,S) B PART			
69	SK-B377705A	KNOB EDIT(2) (L) B PART			
70	SK-B377705B	KNOB EDIT(2) (R) B PART			
71	SK-B377705C	KNOB EDIT(2) (DELETE) B PART			

INDEX

Part No.	Ref. No.	Part No.	Ref. No.	Part No.	Ref. No.	Part No.	Ref. No.
BA-P2026A120C	1A	ED-346568	D15	EI-374176	X1	ET-310148	TR12
BA-P2026A120D	1B	ED-346568	D16	EI-377191	45	ET-318237	73
BA-P2026A120F	1C	ED-346591	18	EI-377191	IC4	ET-318237	TR20
BA-P2026A150B	3	ED-346591	D9	EI-377246	50	ET-322598	72
BA-P2027A040A	2A	ED-356424	9	EI-377246	IC13	ET-322598	TR14
BA-P2027A040B	2B	ED-356424	D17	EI-377767	40	ET-344176	81
BD-P2026A140C	31	ED-356424	D18	EI-377767	IC1	ET-344176	TR13
BM-328441	2	ED-360409	10	EI-377855	51	ET-347026	71
BM-328441	45	ED-360409	D1	EI-377855	IC3	ET-347026	TR16
BM-328441	55	ED-367576	15	EI-377857	33	ET-348829	67
BM-381926J	1	ED-367576	D16	EI-377857	IC8	ET-348829	TR11
BM-381926J	78	ED-377861	25	EI-377860	41	ET-348831	75
BO-377825	3	ED-377861	IC2	EI-377860	IC12	ET-348831	TR10
BO-377825	60	ED-379184	13	EI-380319J	42	ET-349081	77
BR-377659	39	ED-379184	D9	EI-380319J	IC7	ET-349081	TR19
BT-368261	8	ED-379184	D10	EJ-368063	P3	ET-349081	TR3
BT-368261	PT1	ED-379184	D11	EJ-368260	J11	ET-349081	TR8
BT-377885J1	7	ED-379184	D12	EJ-374191	P1	ET-349718	69
BT-377885J1	7A	EF-258344	29	EJ-380560J	J101	ET-349718	TR201
BT-377888J1	5	EF-258344	F1B	EM-377851	54	ET-352726	70
BT-377888J1	7B	EF-258344	F2B	EM-377851	IN1	ET-352726	TR11
BT-377889J1	6	EF-305703	31	EO-B375723	68	ET-352726	TR2
BT-377889J1	7C	EF-305703	F3A	EO-B375725	69	ET-352726	TR9
BT-377890J1	4	EF-305703	F3B	EO-338409	L1	ET-352726	TR13
BT-377890J1	7D	EF-309392	30	EO-345913	L1	ET-353899	68
BV-B375720	66	EF-309392	F1A	EO-377922	L1	ET-353899	TR18
EC-320548	C1A	EF-309392	F2A	EQ-348929	55	ET-354083	78
EC-320548	C2A	EF-358641	27	EQ-348929	RL1	ET-354083	TR6
EC-320548	C3A	EF-358641	F1C	EQ-348929	RL2	ET-354083	TR8
EC-338411	C1B	EF-358641	F2C	ER-322332	R71	ET-354083	TR15
EC-338411	C2B	EF-359342	26	ER-371844	IB4	ET-356817	74
EC-338411	C3B	EF-359342	F3C	ER-378672J	R32	ET-356817	TR7
EC-367928	C1C	EF-359342	F4C	ER-378672J	R33	ET-356817	TR9
ED-301911	11	EF-668474	28	ES-344253	56	ET-360067	76
ED-301911	D3	EF-668474	F3B	ES-344253	24	ET-360067	TR1
ED-301911	D8	EF-668474	F4B	ES-344257	57	ET-360067	TR3
ED-301911	D20	EH-348116	IB5	ES-344257	47	ET-360067	TR4
ED-301911	D1	EH-348116	IB6	ES-344257	48	ET-360067	TR5
ED-301911	D2	EH-352061	IB1	ES-344257	49	ET-360067	TR10
ED-301911	D4	EH-364919	IB3	ES-349464	61	ET-360067	TR12
ED-301911	D6	EH-378669J	IB2	ES-349464	VS1	ET-360067	TR17
ED-301911	D21	EH-380185J	32	ES-349474	62	ET-360067	TR21
ED-306010	20	EH-380185J	FL901	ES-349474	TS1	ET-365456	79
ED-306010	D19	EH-380185J	FL1	ES-349474	TS2	ET-365456	TR2
ED-306013	23	EH-380185J	FL2	ES-349474	TS3	ET-370634	64
ED-306013	D21	EH-380185J	FL3	ES-349474	TS4	ET-370634	TR7
ED-306013	D22	EH-380185J	FL101	ES-349474	TS5	ET-370809	80
ED-330622	14	EI-336794	38	ES-349474	TS6	ET-370809	TR101
ED-330622	D2	EI-336794	IC2	ES-349474	TS7	ET-371075	63
ED-330622	D10	EI-336794	IC3	ES-349474	TS8	ET-371075	TR5
ED-330622	D11	EI-336794	IC4	ES-349474	TS9	ET-371075	TR6
ED-330622	D12	EI-336794	IC5	ES-349474	TS10	ET-373392	66
ED-330622	D13	EI-349372	52	ES-349474	TS11	ET-373392	TR4
ED-330622	D17	EI-349372	X2	ES-349474	TS12	ET-373485	65
ED-330622	D18	EI-349719	43	ES-349474	TS13	ET-373485	TR1
ED-330622	D23	EI-349719	IC10	ES-349474	TS14	EV-356577	VR201
ED-330622	D24	EI-349719	IC11	ES-349474	TS15	EV-356582	VR2
ED-330622	D25	EI-360039	48	ES-349474	TS16	EV-357619	VR1
ED-330622	D7	EI-360039	IC5	ES-349474	TS17	EV-358829	VR2
ED-330622	D8	EI-360040	47	ES-349474	TS18	EV-358829	VR3
ED-330962	19	EI-360040	IC4	ES-349474	TS19	EV-358829	VR202
ED-330962	D6	EI-360040	IC1	ES-349474	TS20	EV-378744J	83
ED-330962	D7	EI-362588	44	ES-349474	TS21	EV-378744J	VR101
ED-343410	21	EI-362588	IC5	ES-349474	TS22	EV-380682J	VR1
ED-343410	D3	EI-362588	IC101	ES-349474	TS23	EW-363634	11B
ED-344280	12	EI-362975	37	ES-349474	TS24	EW-363659	11A
ED-344280	D4	EI-362975	IC6	ES-349474	TS25	EW-363672	11C
ED-344280	D5	EI-367271	49	ES-349474	TS26	EW-363684	11D
ED-344280	D14	EI-367271	IC1	ES-349474	TS27	EZ-302906	12
ED-344280	D15	EI-368608	34	ES-349474	TS28	EZ-323793	30
ED-346526	22	EI-368608	IC201	ES-349474	TS29	EZ-323793	35
ED-346526	D19	EI-368609	35	ES-349474	TS30	MB-375732	62
ED-346526	D20	EI-368609	IC9	ES-349474	TS31	MB-375733	73
ED-346545	24	EI-368610	36	ES-377828J	58	MB-377660	84
ED-346545	D1	EI-368610	IC1	ES-377828J	SW1	MB-377660	33
ED-346558	16	EI-368611	39	ES-377848	59	MB-377914	85
ED-346558	D5	EI-368611	IC2	ES-377848	SW101	MB-377914	34
ED-346558	D13	EI-368612	46	ES-377867	60	ML-377647A	13
ED-346558	D14	EI-368612	IC3	ES-377867	SW1	ML-377652	20
ED-346568	17	EI-374176	53	ET-310148	82	ML-377653	21

Part No.	Ref. No.	Part No.	Ref. No.	Part No.	Ref. No.	Part No.	Ref. No.
ML-377668	28	ZS-342209	82				
ML-377689	29	ZS-345272	52				
ML-380551J1	14	ZS-345272	5				
MR-345182	44	ZS-350934	17				
MR-377657	36	ZS-351204	18				
MR-377658	54	ZS-351204	26				
MS-375730	61	ZS-351886	12				
MS-377649A	18	ZS-353355	13				
MS-380550J1	19	ZS-353355	87				
MZ-B377909	74	ZS-355149	2				
MZ-352143	86	ZS-355511	30				
MZ-352143	56	ZS-355511	46				
MZ-375728	70	ZS-358803	81				
MZ-375729	71	ZS-376293	95				
MZ-377656	58	ZS-376361	50				
MZ-377667	87	ZS-376523	81				
MZ-377667	53	ZS-377153	25				
MZ-377671	3	ZS-377679	80				
MZ-377826	4	ZS-377926	65				
MZ-553948	91	ZS-377928	25				
SA-B368687	89	ZS-377930	42				
SC-B377673	5	ZS-377930	57				
SC-P2027A060A	7	ZS-378512J	26				
SC-377654	31	ZS-378525J	22				
SC-377655	32	ZS-378680J	64				
SC-377907	8	ZS-378683J	75				
SE-375348	10	ZS-378785J	17				
SE-377737	44	ZS-537085	76				
SK-B377701A	53	ZS-608321	27				
SK-B377701B	54	ZW-259503	16				
SK-B377701C	55	ZW-270088	35				
SK-B377701D	56	ZW-270101	1				
SK-B377701E	57	ZW-316800	41				
SK-B377701F	58	ZW-325519	43				
SK-B377701G	59	ZW-376292	94				
SK-B377701H	60	ZW-376391	23				
SK-B377701J	61	ZW-378397	63				
SK-B377701K	62	ZW-378725J	40				
SK-B377701L	63	ZW-378813J	21				
SK-B377703A	64	ZW-516993	59				
SK-B377703B	65	ZW-653163	80				
SK-B377703C	66						
SK-B377703D	67						
SK-B377703E	68						
SK-B377705A	69						
SK-B377705B	70						
SK-B377705C	71						
SK-B377705D	72						
SK-B377705E	73						
SK-373236B	28						
SK-377709	74						
SK-377713A	75						
SK-377713B	76						
SK-377715	77						
SK-377733	34						
SK-377734	36						
SK-377735	37						
SM-365756C	79						
SP-377742	11						
SP-377747	92						
SP-377748	93						
SP-377891	84						
SP-380722J2	9A						
SP-380724J2	9B						
SP-380725J2	9C						
SP-380726J2	9D						
SP-380727J2	9E						
SZ-377677	16						
SZ-377791	37						
ZG-358111	15						
ZG-377680	38						
ZG-377913	79						
ZS-300517	90						
ZS-313796	8						
ZS-320906	6						
ZS-325495	3						
ZS-332009	33						
ZS-332468	14						
ZS-332468	27						
ZS-336613	52						

ABBREVIATIONS (COMPACT DISC)

ABBREVIATION	EXPLANATION	ABBREVIATION	EXPLANATION
A-D	Analog to Digital (Convertor)	Mb	Mega Bits
ADC	Analog to Digital (Convertor)	MDA	Modulation
BCD	Binary Code Decimal	MFM	Modified Frequency Modulation
BPI	Bits per Inch	MM	Mono-stable Multivibrator
CD	Compact Disc	M : FM	Modified Modified Frequency Modulation
CIRC	Cross Interleaving & Reed Solomon Coding	MOD 2	Module 2 (Addition)
CLV	Constant Linear Velocity	MP	Microprocessor
CP	Clock Pulses	MSB	Most Significant Bit
CRCC	Cyclic Redundancy Check Codes	NA	Numerical Aperture
D Level	Decision Level	NRZ	Non Return to Zero
D-A	Digital to Analog (Convertor)	NRZ-I	Non Return to Zero Inverted
DAC	Digital to Analog (Convertor)	P	Parity Data
DAD	Digital Audio Disk	PAM	Pulse Amplitude Modulation
DEM	Dynamic Element Matching	PCM	Pulse Code Modulation
DPD	Differential Phase Detection	PD	Phase Detector
DSV	Digital Sum Value	PE	PHASE Encode
EFM	Eight to Fourteen Modulation	PLL	Phase Locked Loop
EX-OR	EXclusive OR	PNM	Pulse Number Modulation
FIC	Flux Changes per Inch	PPM	Pulse Phase Modulation
FIR	Finite Impulse Response	PWM	Pulse Width Modulation
FP	Front Pulse	Q	Parity Data
FPG	Front Pulse Gate	R.R ₁ , R ₂ , etc	Data for Right Channel
f	Frequency of Sampling	RAM	Random Access Memory
GF	Galois Field	RPG	Rear Pulse Gate
H & V (Parity)	Horizontal & Vertical	SCOOP	Self Coupled Optical Pick-up
IIR	Infinite Impulse Response	S & H	Sample & Hold
kb	Kilo Bits	S/N	Signal to Noise Ratio
L.L ₁ , L ₂ , etc	Data for Left Channel	SSG	Standard Signal Generator
LPF	Low Pass Filter	SYS CON	SYSTEM CONTROL
LSB	Least Significant Bit		

AKAI ELECTRIC CO., LTD.

12-14, 2-Chome, Higashi-Kojiya, Ohta-ku, Tokyo, Japan

TEL: Tokyo (742) 5111 CABLE: HIFIAKAI TOKYO TELEX: J26261

Printed No. 871222-G1-2400

Printed Date: February 2, 1988

350 Printed in Japan

AKAI

MODEL CD-73

SCHEMATIC DIAGRAM AND PC BOARDS

TABLE OF CONTENTS

1. POWER AND HP PC BOARDS	2
2. CONNECTION DIAGRAM.....	3
3. DIGITAL SCHEMATIC DIAGRAM.....	4
4. DIGITAL AND OTHER PC BOARDS.....	5
5. ANALOG SCHEMATIC DIAGRAM.....	6
6. ANALOG PC BOARD.....	7
7. OPERATION SCHEMATIC DIAGRAM.....	8
8. OPERATION PC BOARD.....	9
9. ANALOG BLOCK DIAGRAM.....	10
10. BLOCK DIAGRAM	11
11. IC'S.....	12

TO ANALOG PCB P2

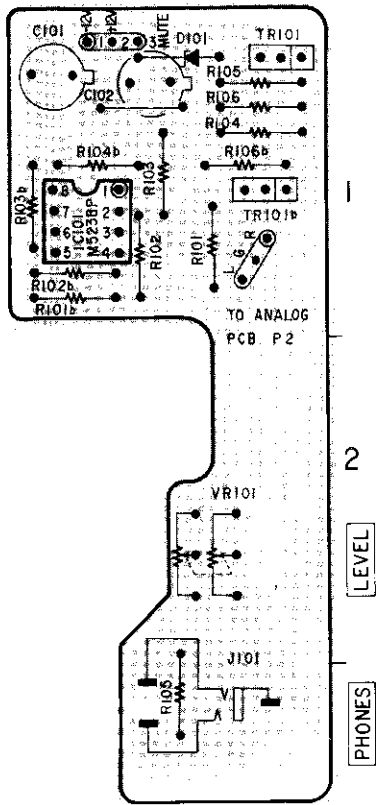

A

H.P PCB P2026A5038

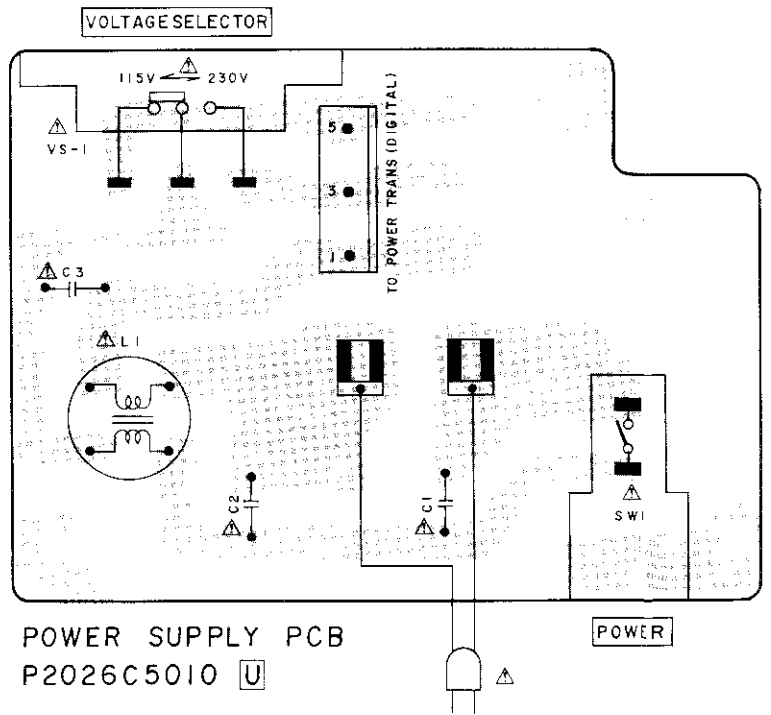

POWER SUPPLY PCB
P2026C5010 U

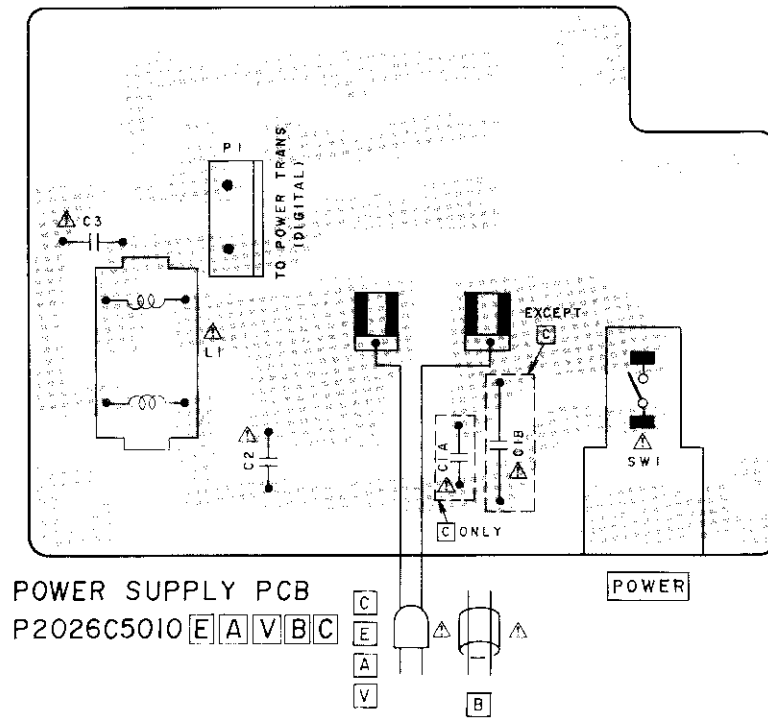

POWER SUPPLY PCB
P2026C5010 E A V B C

WARNING: Δ INDICATES SAFETY CRITICAL COMPONENTS. FOR CONTINUED SAFETY, REPLACE SAFETY CRITICAL COMPONENTS ONLY WITH MANUFACTURER'S RECOMMENDED PARTS.

AVERTISSEMENT: Δ IL INDIQUE LES COMPOSANTS CRITIQUES DE SÉCURITÉ. POUR MAINTENIR LE DEGRÉ DE SÉCURITÉ DE L'APPAREIL, NE REMPLACER QUE DES PIÈCES RECOMMANDÉES PAR LE FABRICANT.

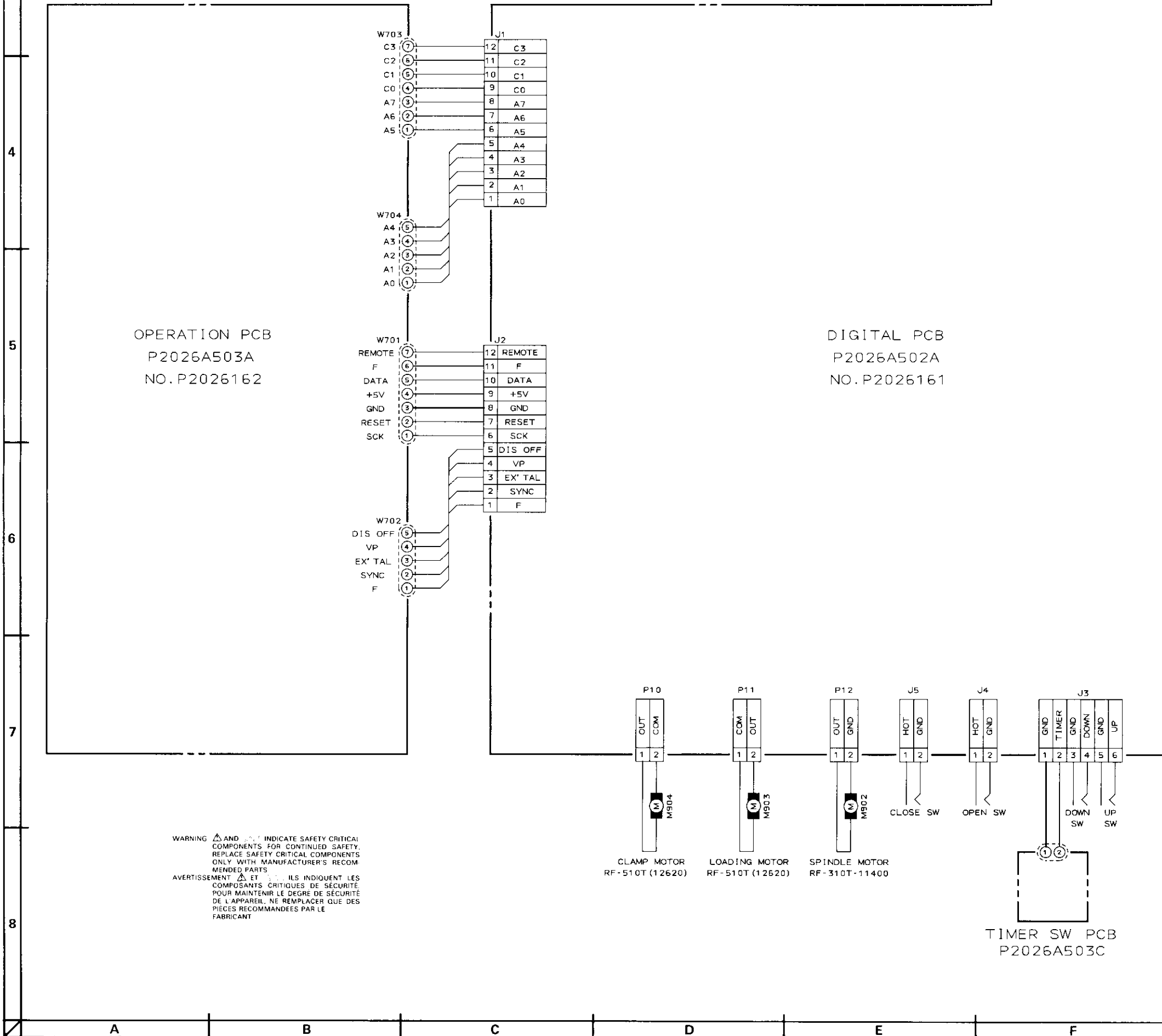
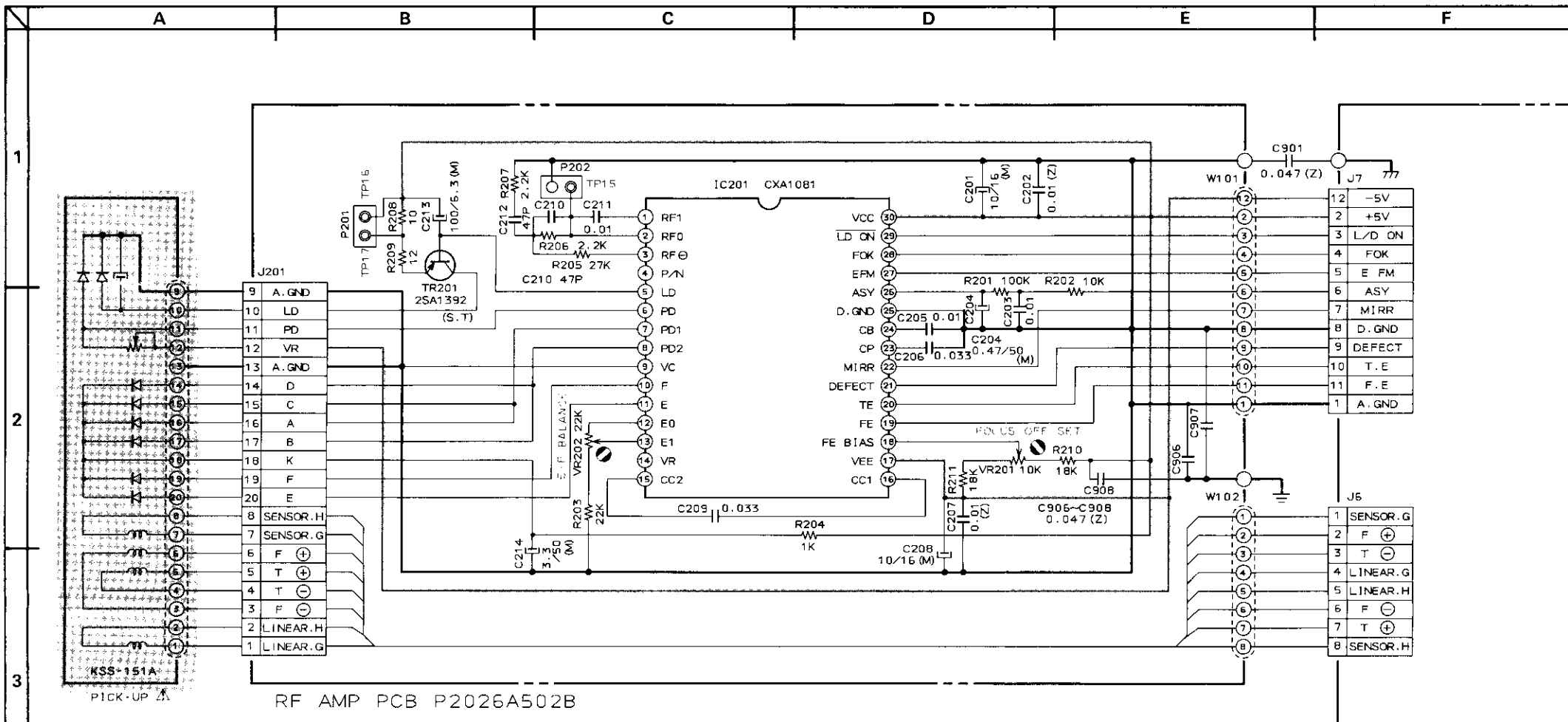

WARNING AND INDICATE SAFETY CRITICAL COMPONENTS FOR CONTINUED SAFETY. REPLACE SAFETY CRITICAL COMPONENTS ONLY WITH MANUFACTURER'S RECOMMENDED PARTS.

AVERTISSEMENT ET ILS INDIQUENT LES COMPOSANTS CRITIQUES DE SÉCURITÉ. POUR MAINTENIR LE DEGRÉ DE SÉCURITÉ DE L'APPAREIL, NE REMPLACER QUE DES PIÈCES RECOMMANDÉES PAR LE FABRICANT.

TIMER SW PCB P2026A503C

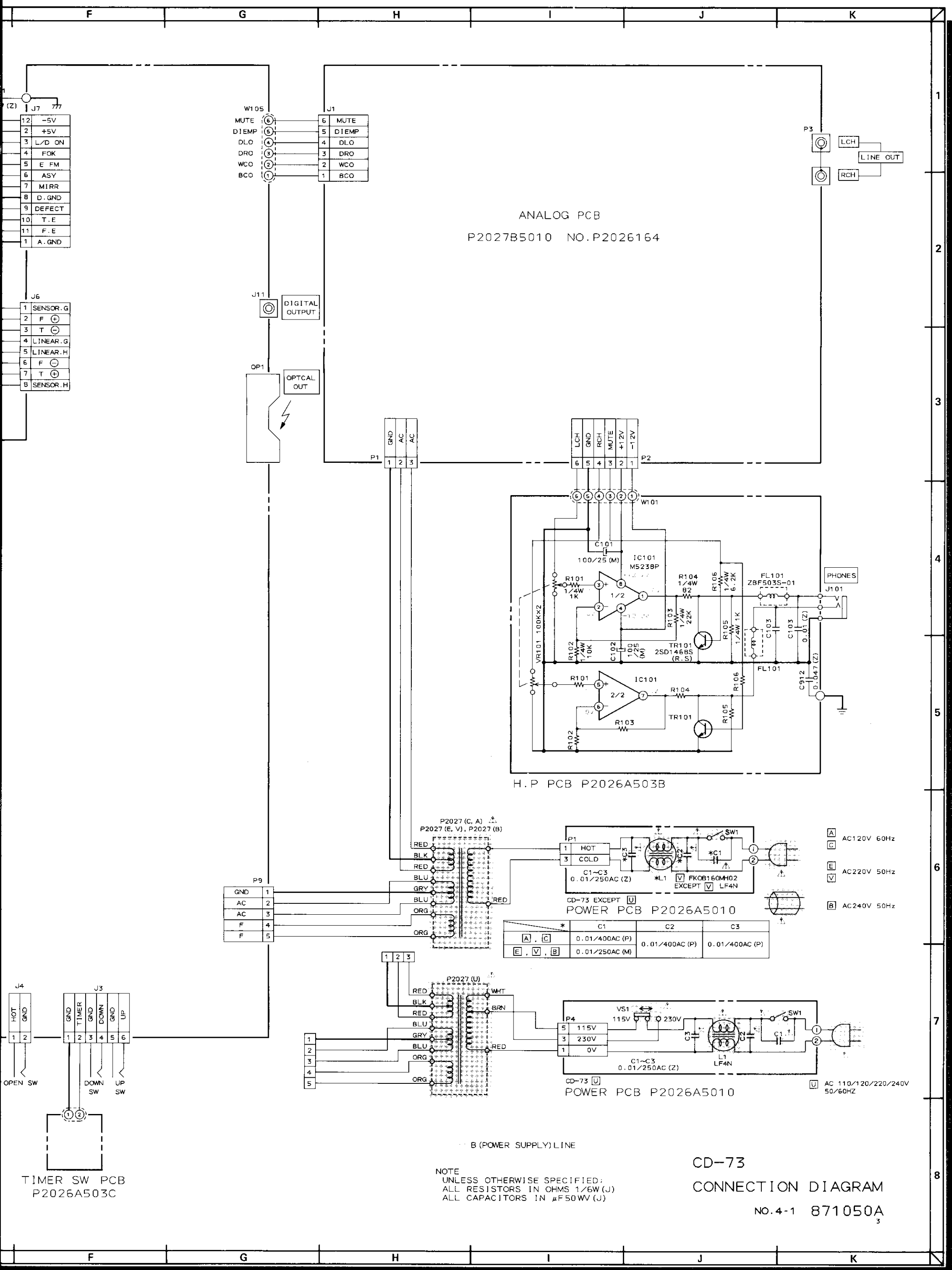

ANALOG PCB
P2027B5010 NO.P2026164

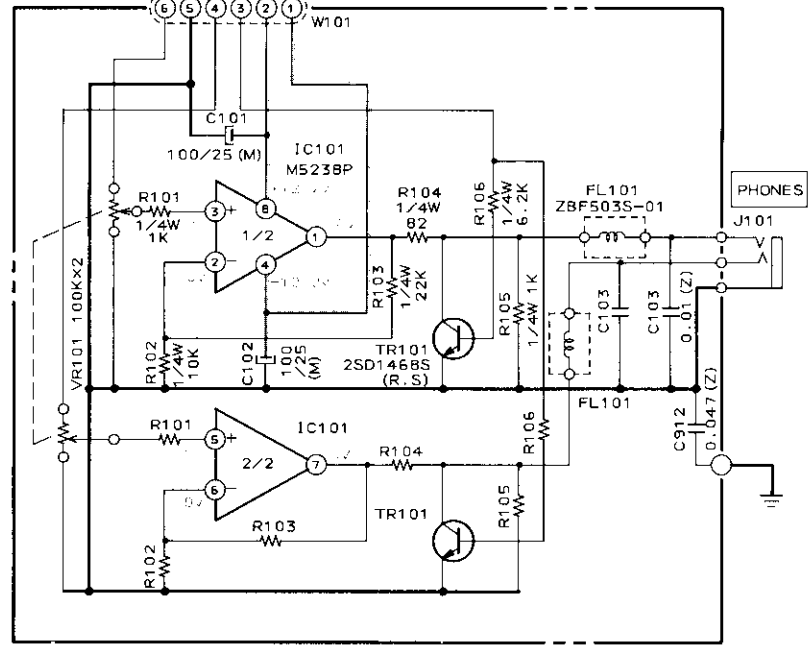

H.P. PCB P2026A503B

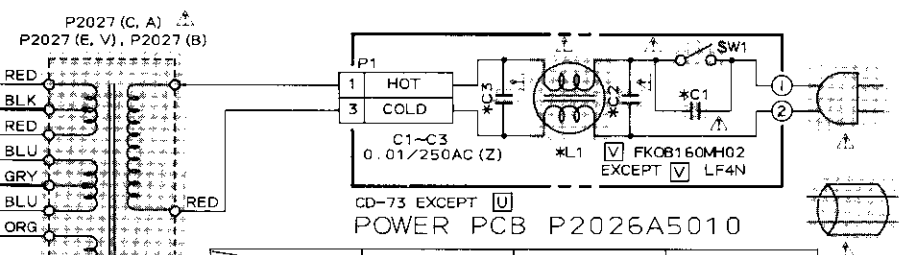

POWER PCB P2026A5010

	C1	C2	C3
[A], [C]	0.01/400AC (P)	0.01/400AC (P)	0.01/400AC (P)
[E], [V], [B]	0.01/250AC (M)		

- [A] AC120V 60Hz
- [C] AC220V 50Hz
- [E] AC240V 50Hz
- [V] AC110/120/220/240V 50/60Hz

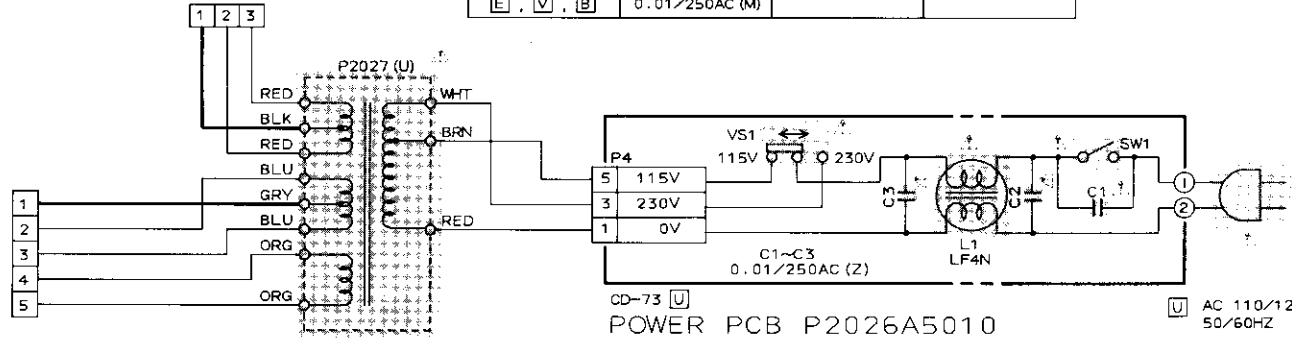

POWER PCB P2026A5010

- [U] AC 110/120/220/240V 50/60Hz

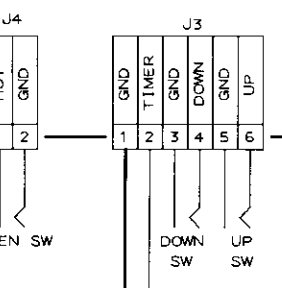

TIMER SW PCB
P2026A503C

NOTE
UNLESS OTHERWISE SPECIFIED:
ALL RESISTORS IN OHMS 1/6W (J)
ALL CAPACITORS IN μF50WV (J)

CD-73
CONNECTION DIAGRAM
NO.4-1 871050A

1
2
3
4
5
6
7
8

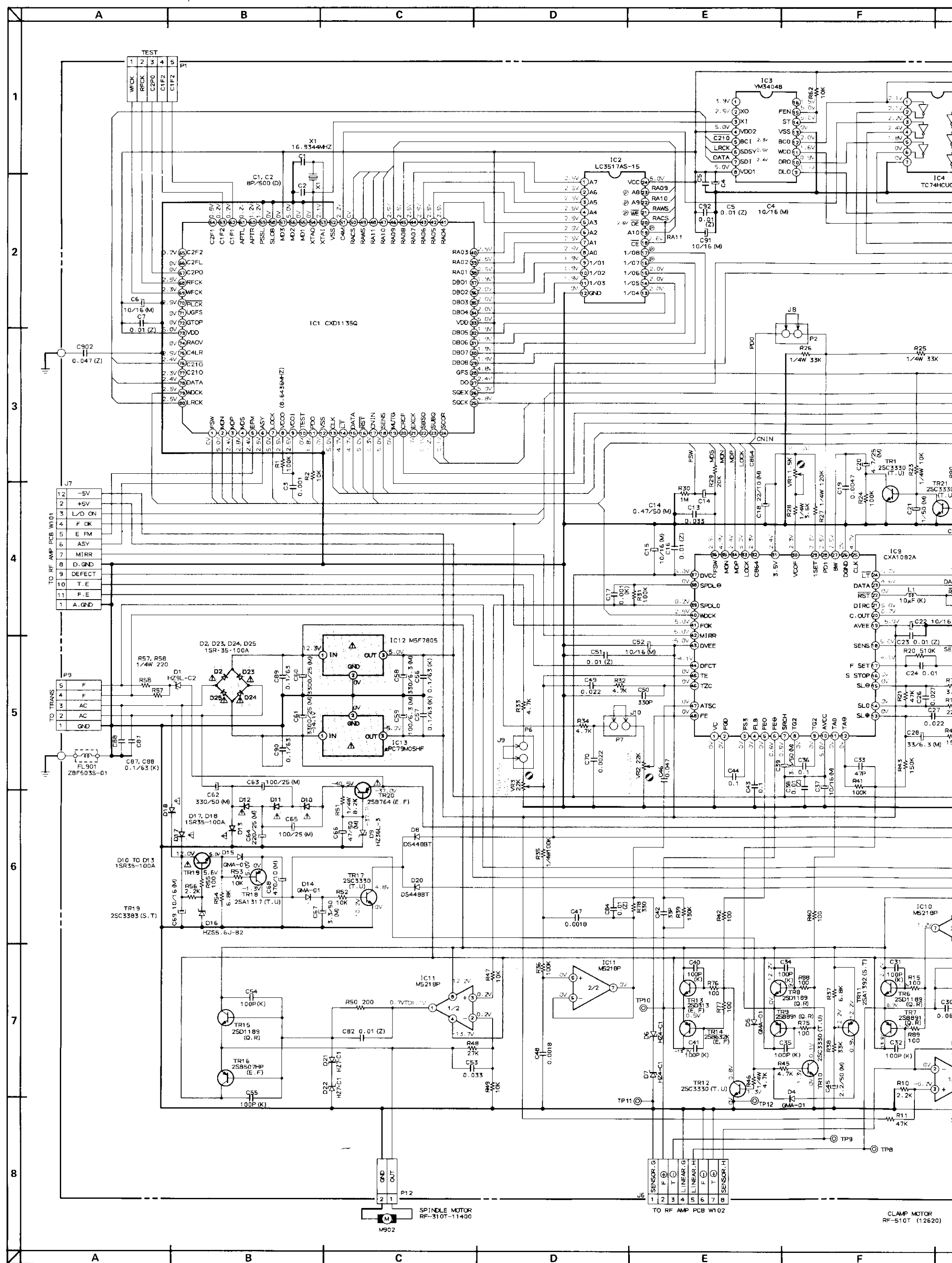

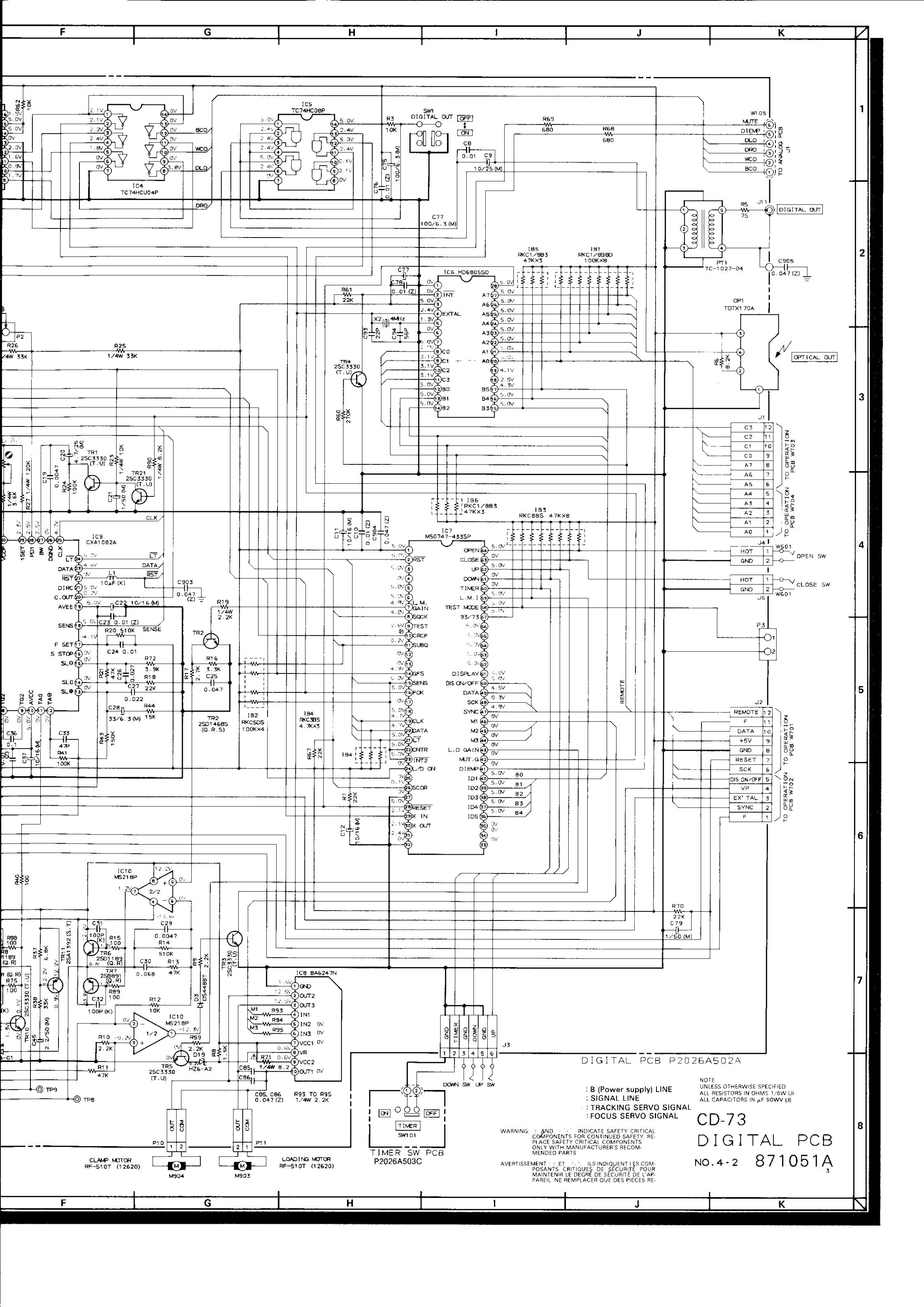

: B (Power supply) LINE
 : SIGNAL LINE
 : TRACKING SERVO SIGNAL
 : FOCUS SERVO SIGNAL

NOTE
 UNLESS OTHERWISE SPECIFIED
 ALL RESISTORS IN OHMS 1/8W (J)
 ALL CAPACITORS IN μ F 50WV (J)

CD-73
DIGITAL PCB
NO. 4-2 871051A

WARNING: AND INDICATE SAFETY CRITICAL COMPONENTS FOR CONTINUED SAFETY. REPLACE SAFETY CRITICAL COMPONENTS ONLY WITH MANUFACTURER'S RECOMMENDED PARTS.

AVERTISSEMENT: ET ILS INDIQUENT LES COMPOSANTS CRITIQUES DE SÉCURITÉ POUR MAINTENIR LE DEGRÉ DE SÉCURITÉ DE L'APPAREIL. NE REMPLACER QUE DES PIÈCES RE-

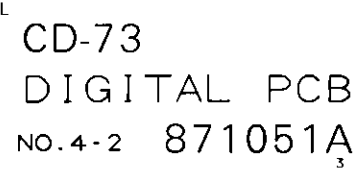
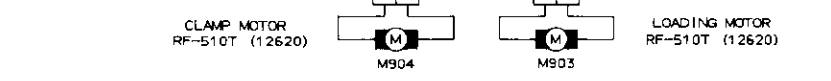
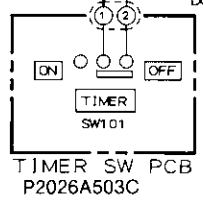

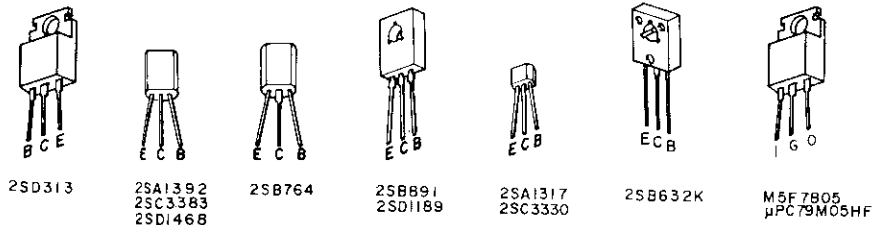

••• = PNP TRANSISTOR
••• = NPN TRANSISTOR

LOCATION OF COMPONENTS

- ICs
IC1...F4
IC2...G4
IC3...F4
IC4...B4
IC5...G3
IC6...A2
IC7...C3
IC8...B3
IC9...E4
IC10...C3
IC11...D2
IC12...E1
IC13...F2

TRANSISTORS

- TR1...F4
TR2...C4
TR3...B3
TR4...A1
TR5...B3
TR6...D3
TR7...D3
TR8...B2
TR9...B2
TR10...C2
TR11...F2
TR12...C2
TR13...C2
TR14...C1
TR15...E1
TR16...D2
TR17...F2
TR18...F3
TR19...F3
TR20...E1
TR21...E4

CONNECTORS

- J1...A2
J2...A3
J3...A1
J4...A1
J5...A1
J6...B1
J7...B1
J8...B2
J9...C1
J10...C1
J11...G1
- P1...F1
P2...F2
P3...A4
P6...C1
P7...C1
P8...D2
P9...G1
P10...B2
P11...C2
P12...E2
OP1...G1

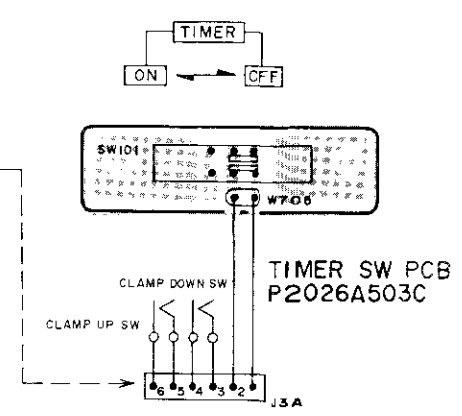
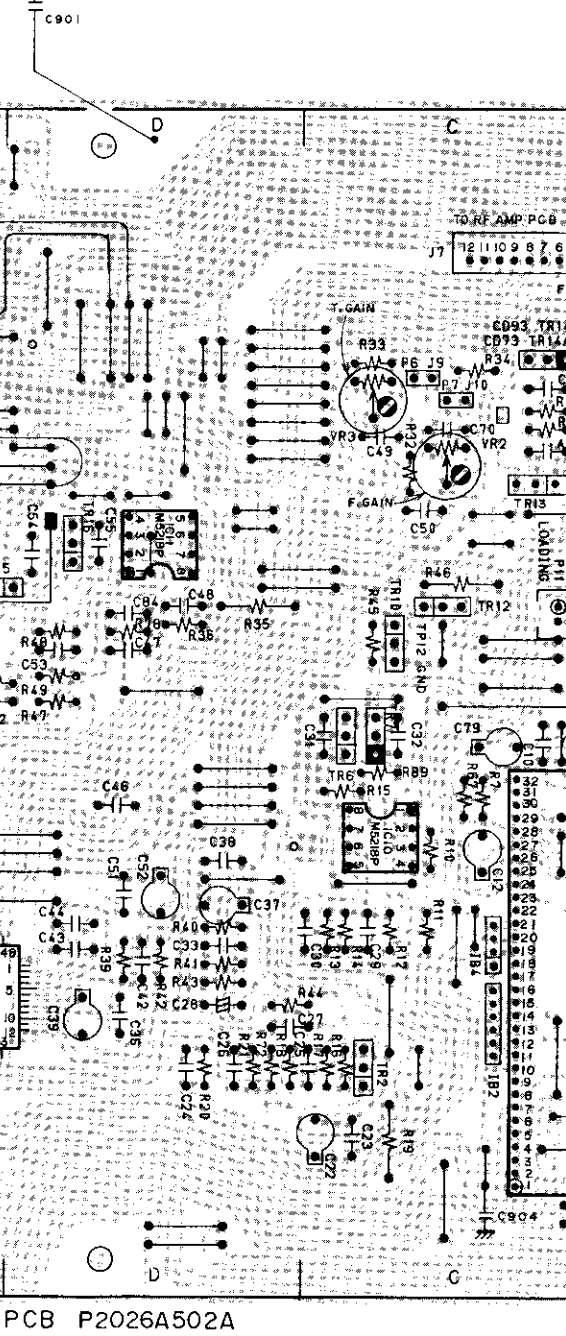
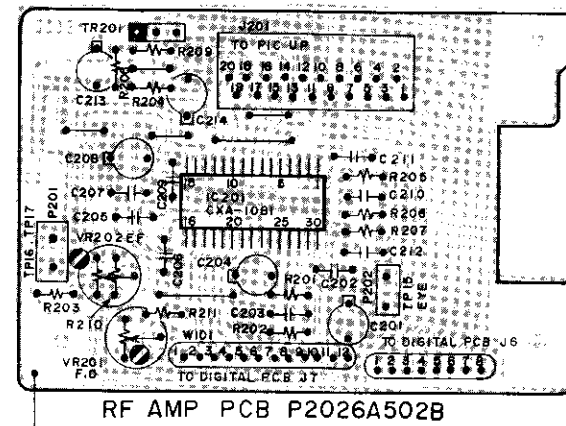

WARNING ⚠ INDICATES SAFETY CRITICAL COMPONENTS FOR CORRECTED SAFETY. REPLACE SAFETY CRITICAL COMPONENTS ONLY WITH MANUFACTURER'S RECOMMENDED PARTS.

AVERTISSEMENT ⚠ INDIQUE LES COMPOSANTS CRITIQUES DE SECURITE. NE REMPLACEZ QUE DES PIECES RECOMMANDEES PAR LE FABRICANT.

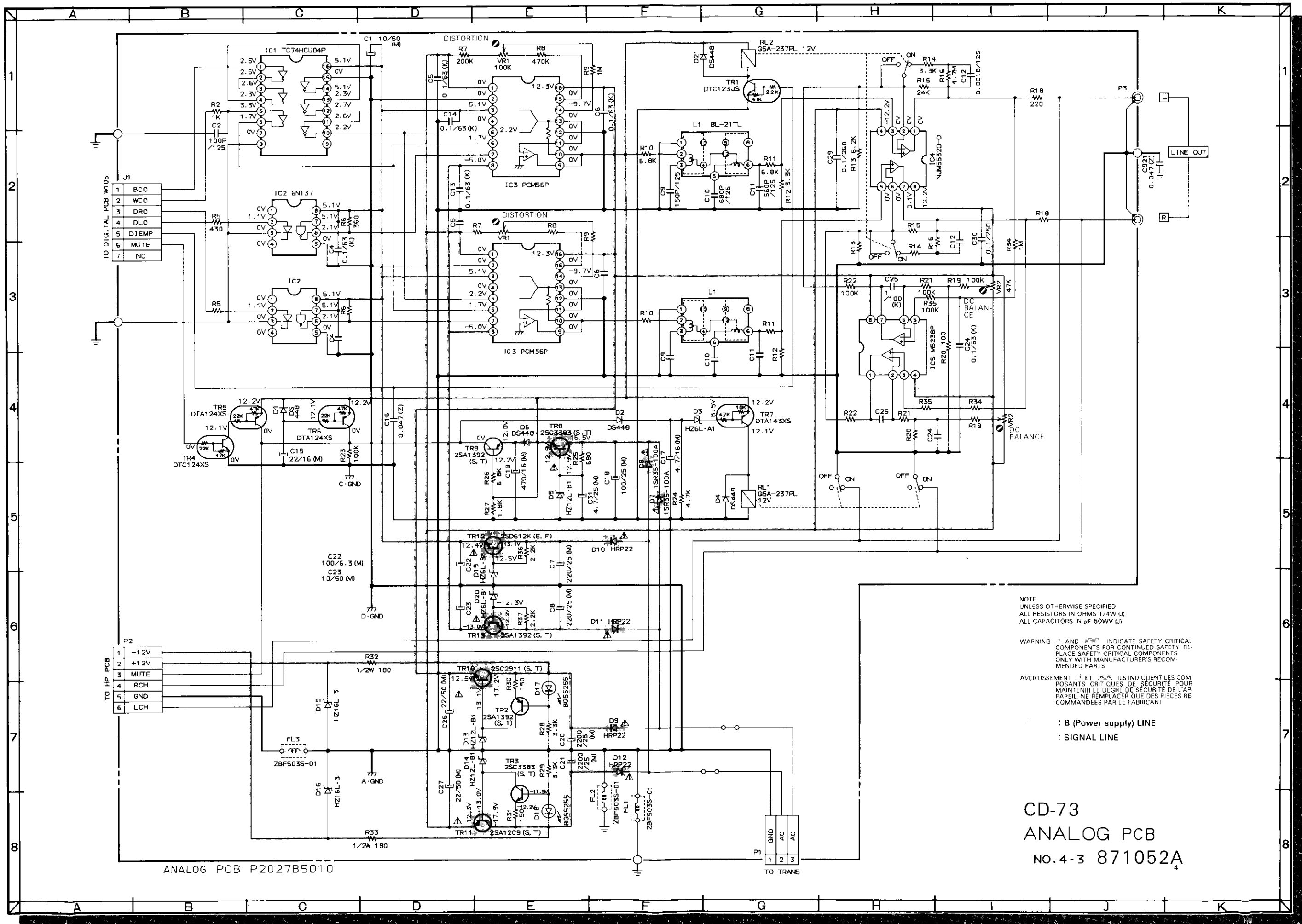

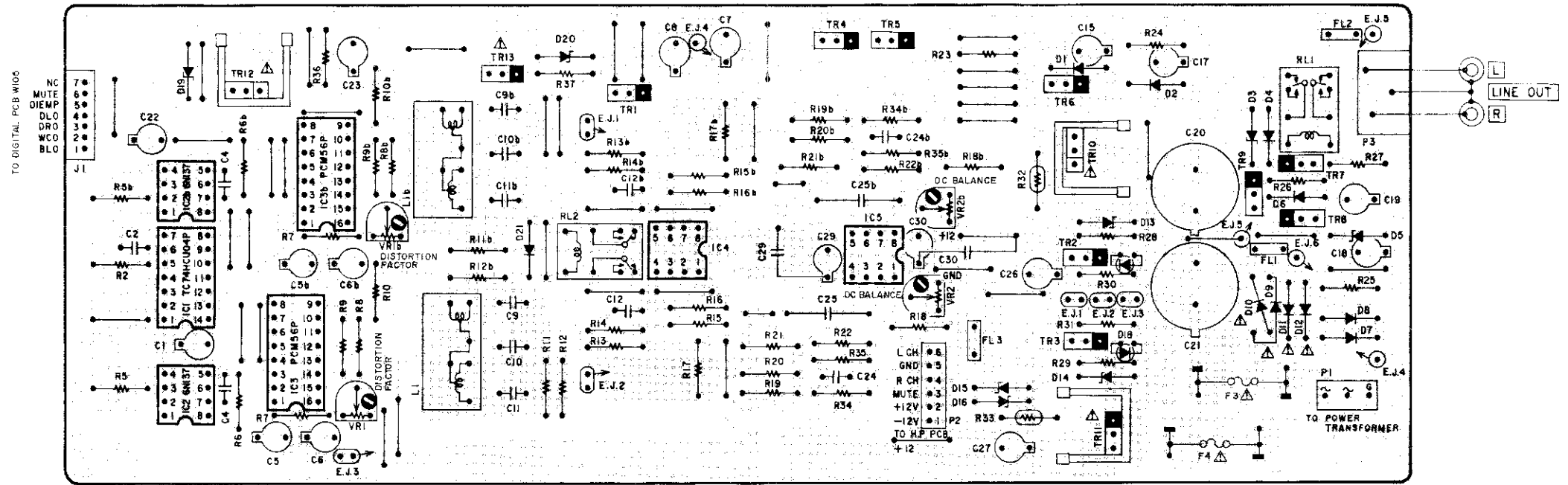

ANALOG PCB P2027B5010 (J1)

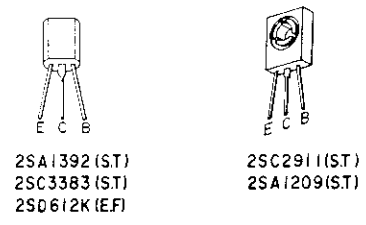
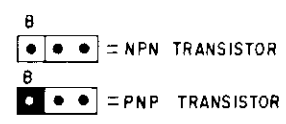

	CA	EVBS
F 3	I25V630mA	T400mA
	I25V630mA	T400mA

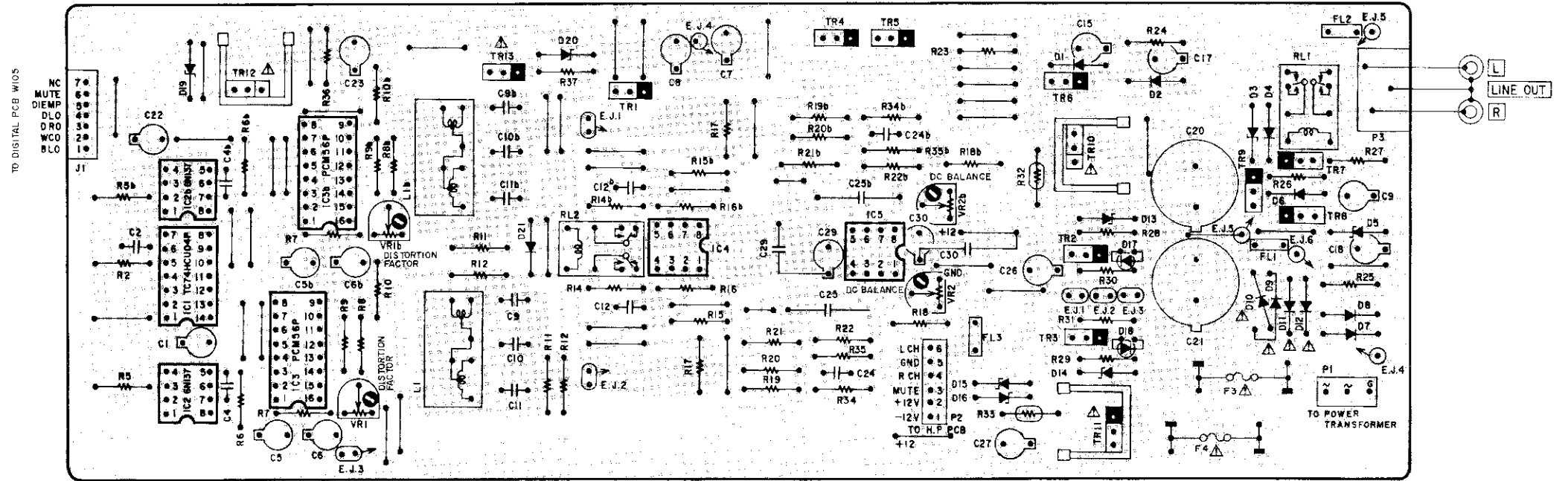

ANALOG PCB P2027B5010 (J2)

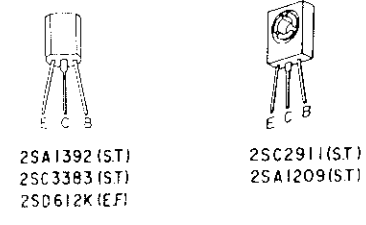
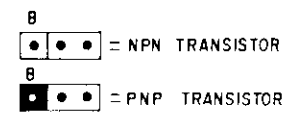

	CA	EVBS
F 3	I25V630mA	T400mA
F 4	I25V630mA	T400mA

WARNING: * INDICATES SAFETY-CRITICAL COMPONENTS FOR CONTINUED SAFETY.
* 印字された部品は安全に重要な部品を示しています。
REPLACE ONLY WITH MANUFACTURER'S RECOMMENDED PARTS.

AVERTISSEMENT: * IL INDIQUE LES COMPOSANTS CRITIQUES DE SECURITE
POUR MAINTENIR LE DEGRÉ DE SECURITE DE L'APPAREIL.
NE REMPLACER QUE DES PIÈCES RECOMMANDÉES PAR LE FABRICANT.

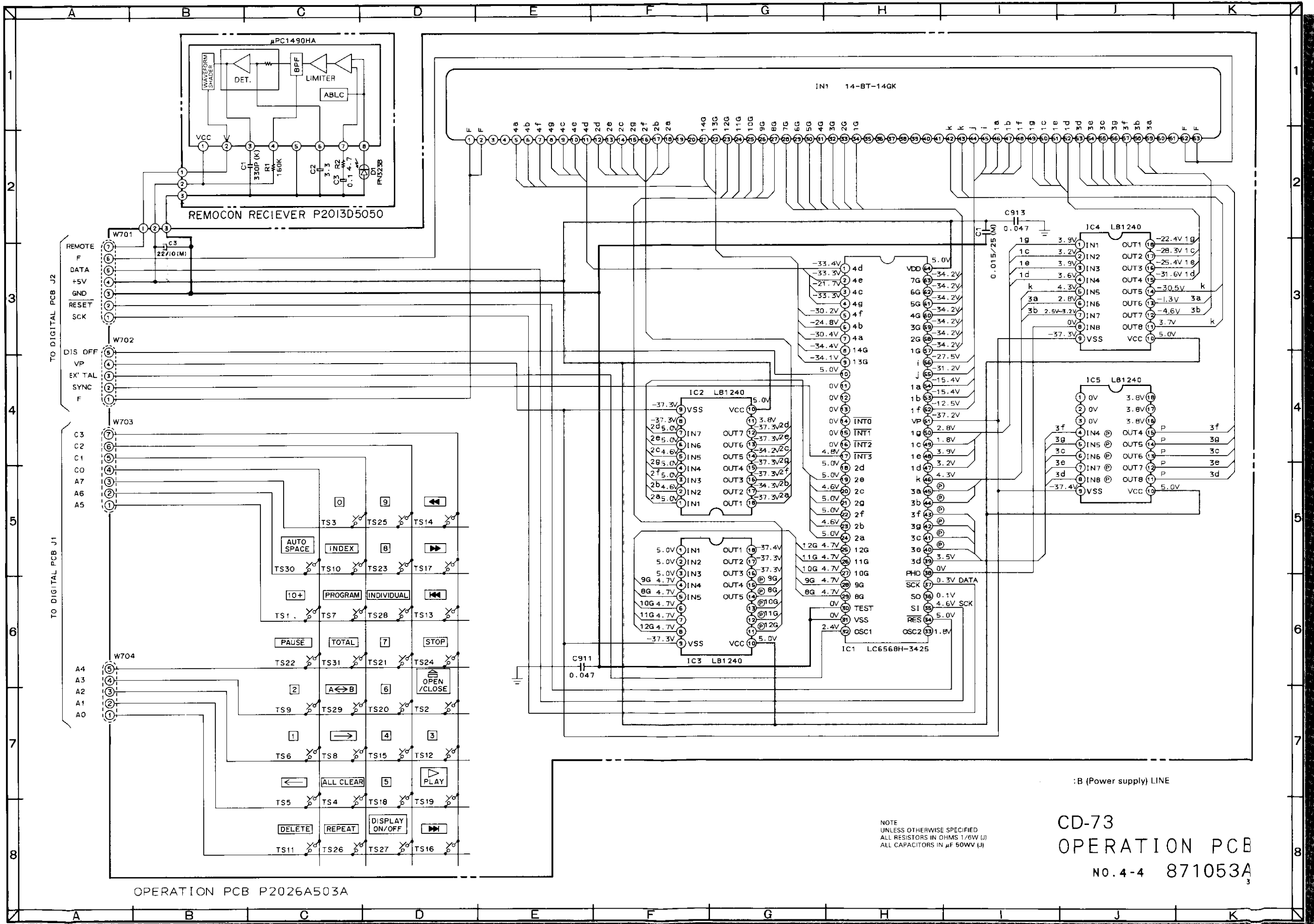

OPERATION PCB P2026A503A

:B (Power supply) LINE
CD-73
OPERATION PCB
 NO. 4-4 871053A

NOTE
 UNLESS OTHERWISE SPECIFIED
 ALL RESISTORS IN OHMS 1/6W (J)
 ALL CAPACITORS IN uF 50WV (J)

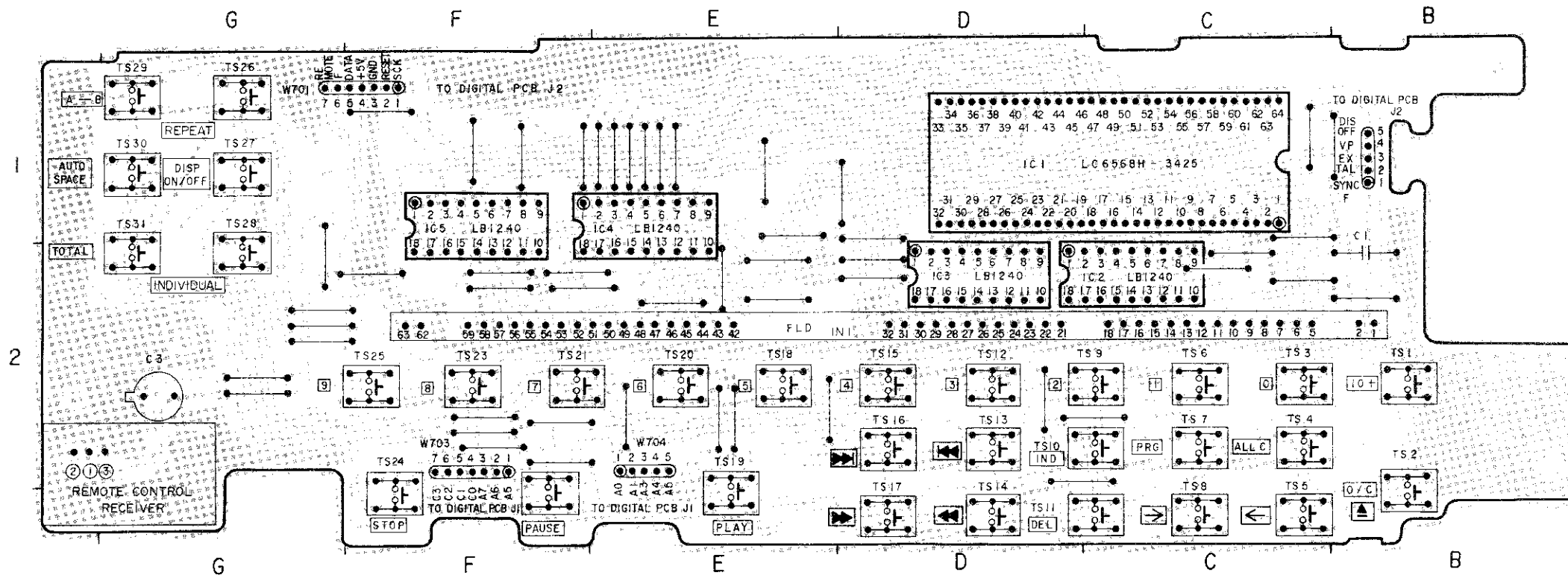

OPERATION PCB P2026A503A

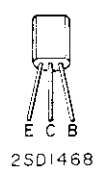

2SD1468

●●● = NPN TRANSISTOR

CD-73

When playing back a 1KHz
of the test disc TYPE III

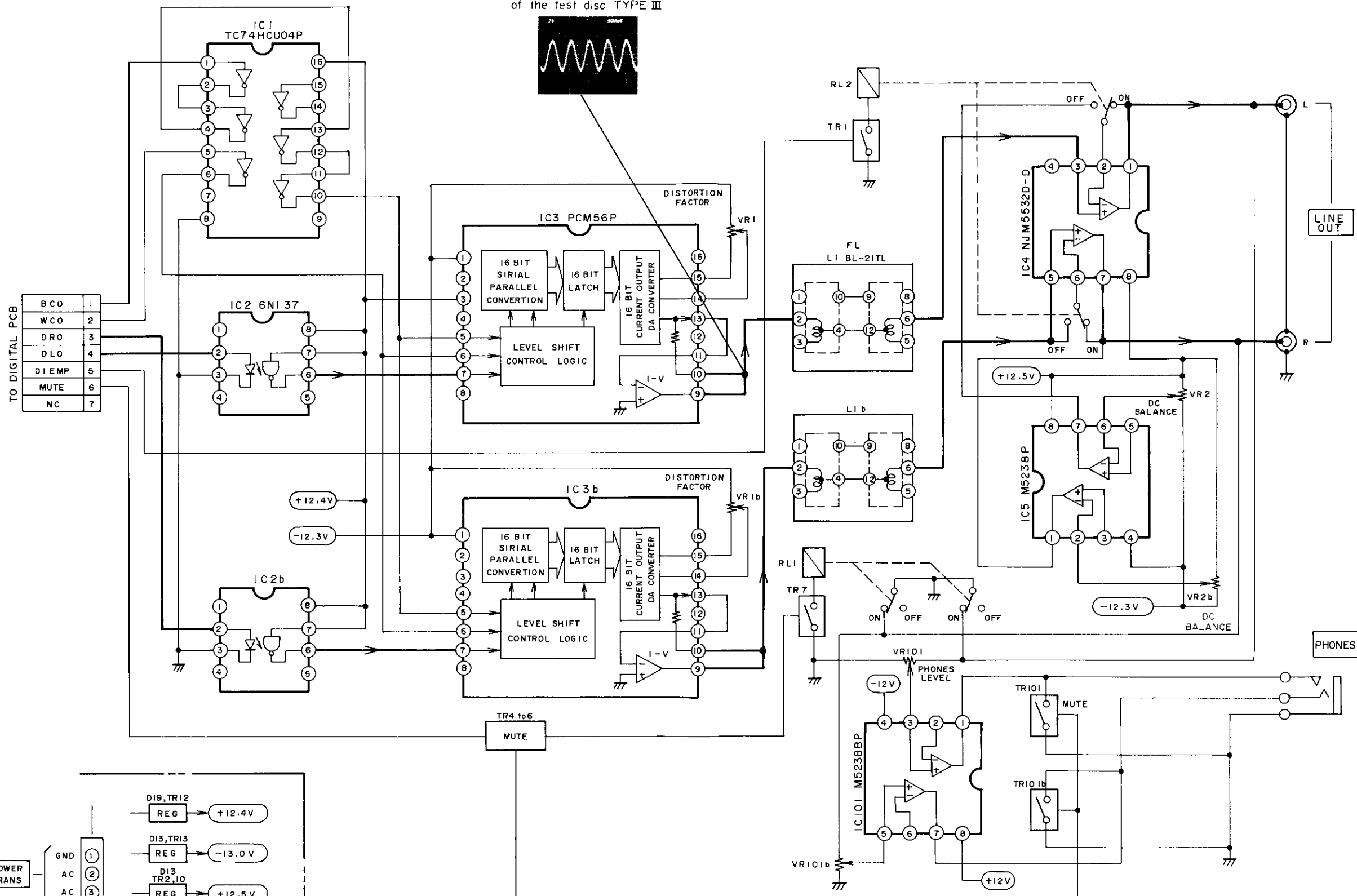
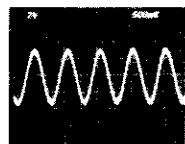

BCO	1
WCO	2
DRO	3
DLO	4
DI EMP	5
MUTE	6
NC	7

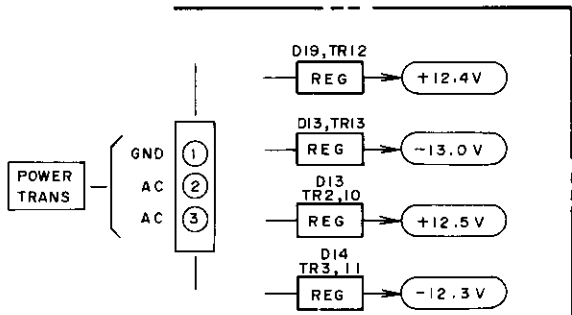

CD-73
 ANALOG BLOCK DIAGRAM
 NO. 2-1 871043B

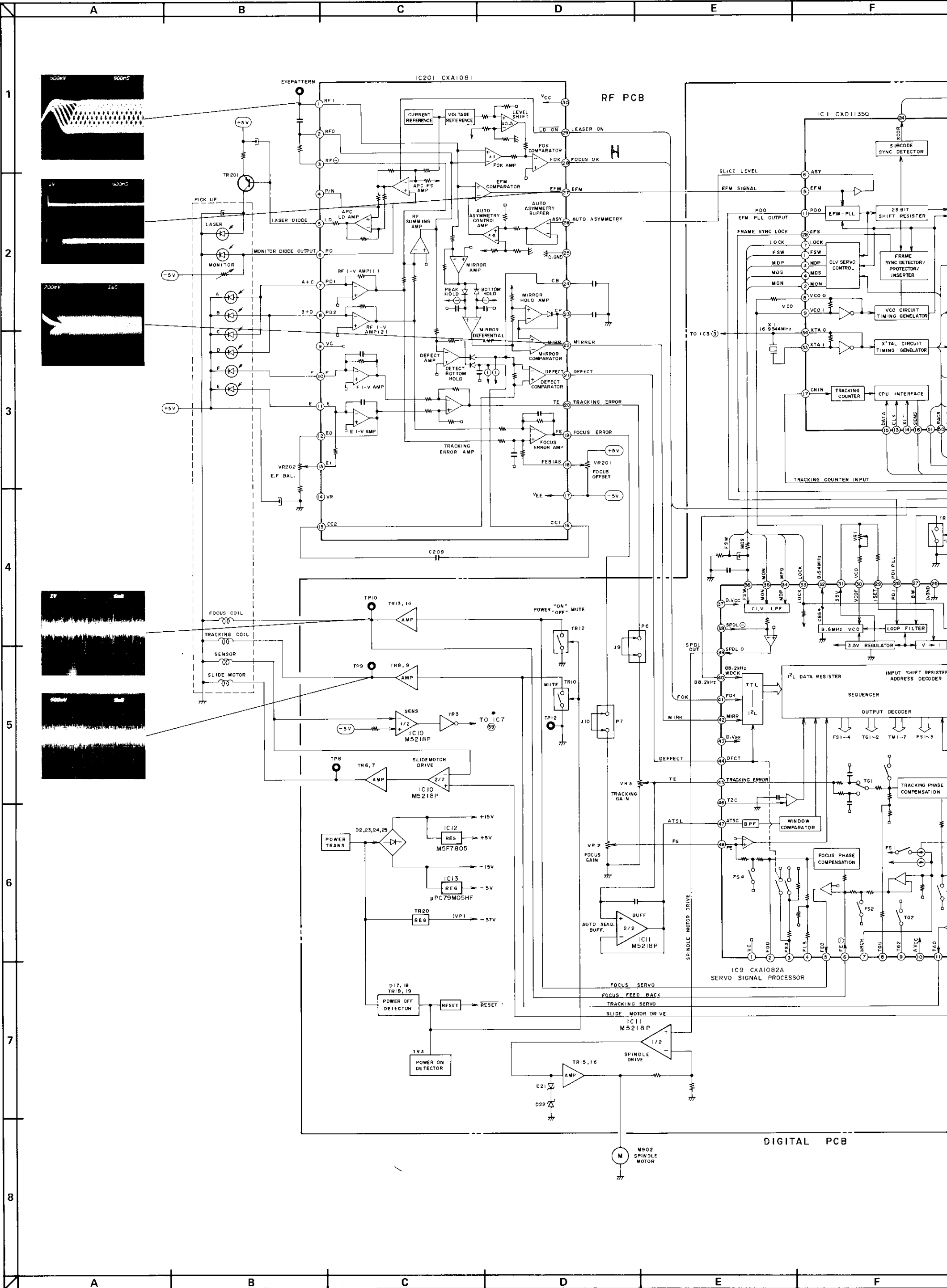

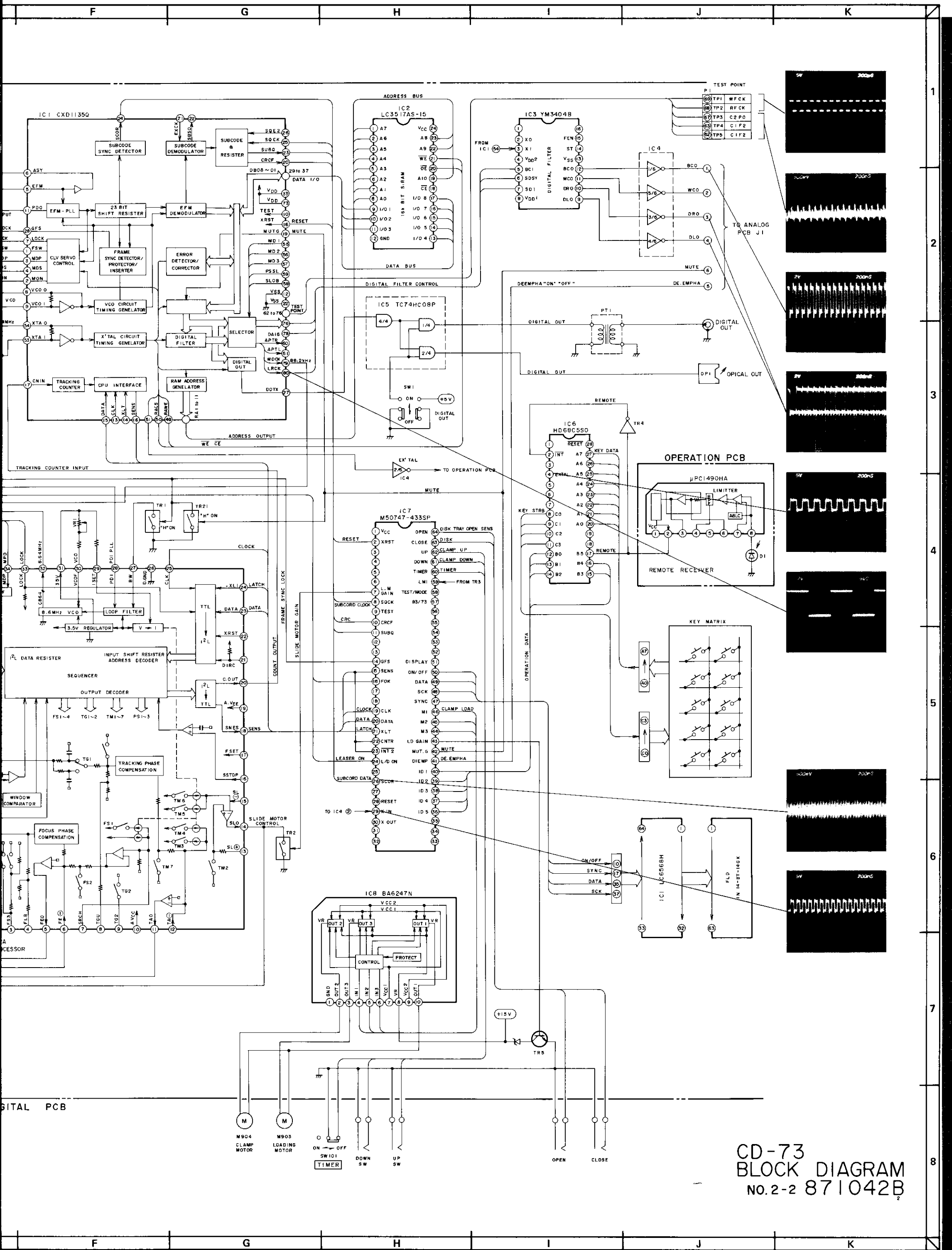

CD-73
BLOCK DIAGRAM
No.2-2 871042B

1
2
3
4
5
6
7
8

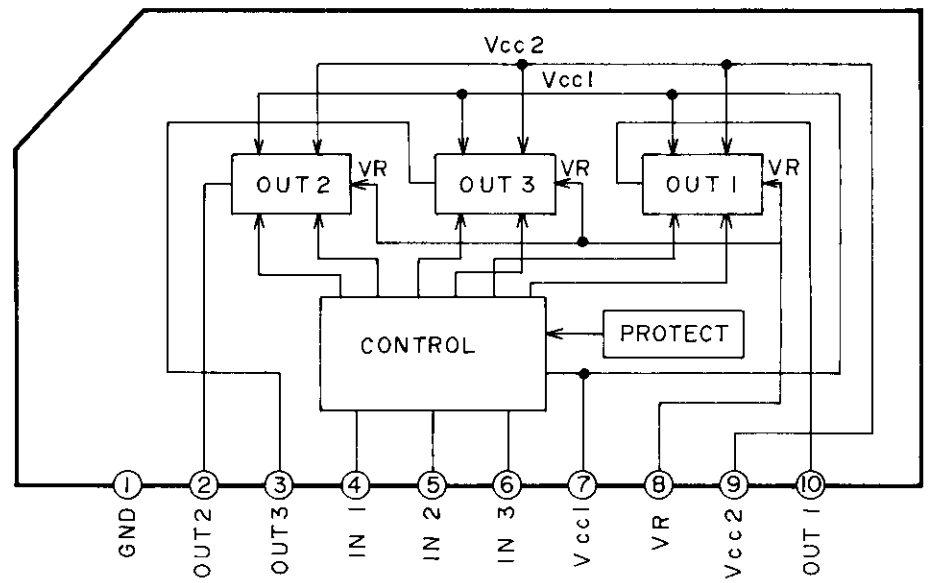

CXD1125Q/CXD1130Q/CXD1135Q

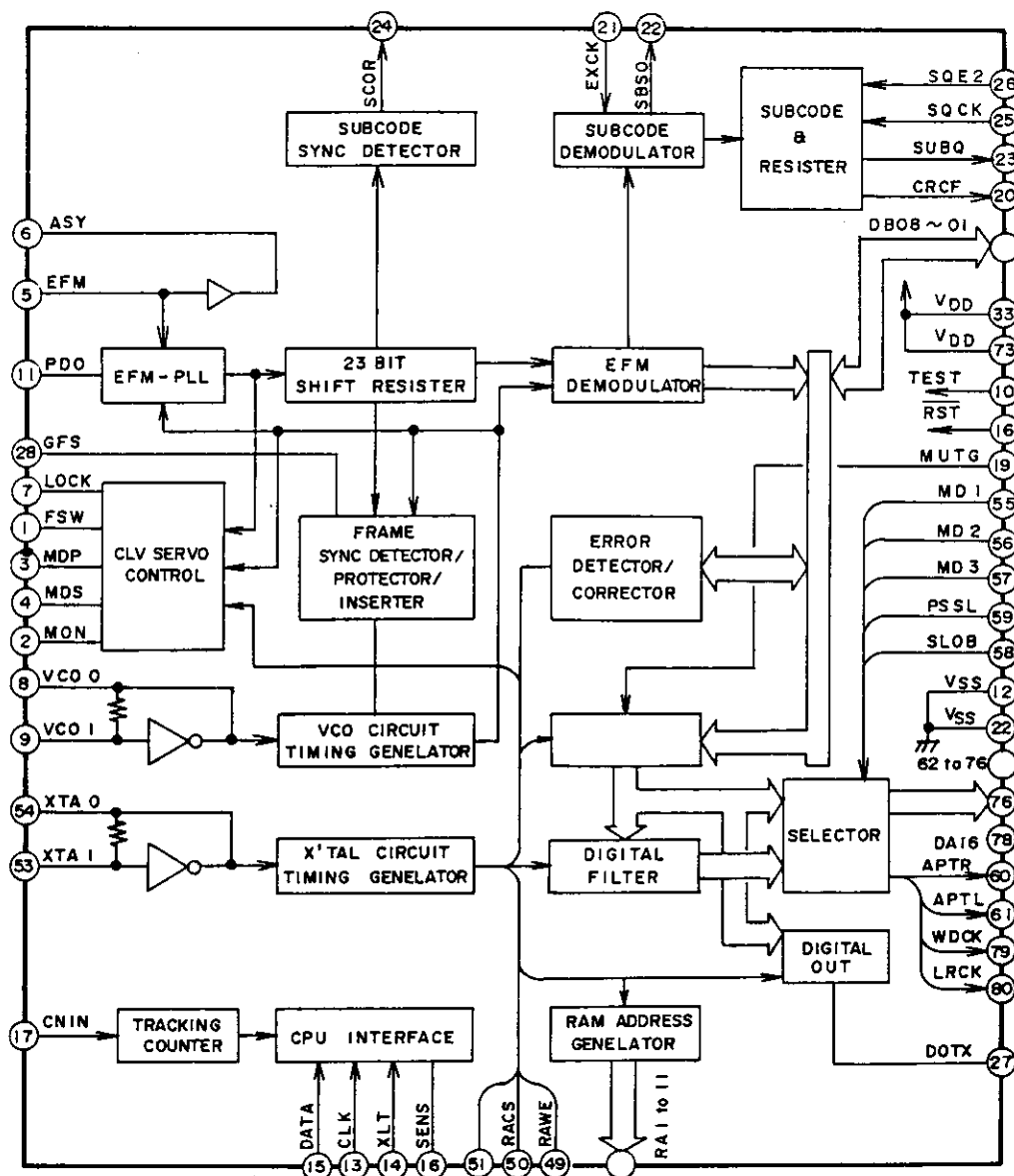

CXD1135Q

No.	Symbol	I/O	Description
1	FSW	O	Spindle motor filter switching control
2	MON	O	Spindle motor ON/OFF control
3	MPD	O	Spindle motor speed and phase control
4	MDS	O	Spindle motor speed control
5	EFM	I	EFM signal input
6	ASY	O	EFM signal slice level control
7	LOCK	O	Slide motor over reach guard signal output
8	VCOO	O	VCO output f=8.6436 MHz
9	VCOI	I	VCO input
10	TEST	I	OV (GND)
11	PDO	O	Phase comp.output
12	VSS	—	GND (OV)
13	CLK	I	Clock signal from CPU
14	XLT	I	Lutch signal from CPU
15	DATA	I	Serial data from CPU
16	RST	I	RESET input "L" reset
17	CNIN	I	Tracking pulse input (5V)
18	SENS	O	Output of CPU interface
19	MUTG	I	Mute control signal input
20	CRCF	O	CRC check output of the subcode Q "L" detect error
21	EXCK	I	NOT USE
22	SBSO	O	NOT USE
23	SUBQ	O	Subcode Q output
24	SCOR	O	Subcode sync detection output
25	SQCK	I/O	Clock signal for subcode Q
26	SQEX	I	Select input of CQCK (+5V)
27	DOTX	O	Digital output
28	GFS	O	"H" frame sync lock "L" frame sync unlock
29	DB08	I/O	Data 8 (MSB) Data Bus line for the EXT.RAM (LC
30	DB07	I/O	Data 7 Data Bus line for the EXT.RAM (LC
31	DB06	I/O	Data 6 Data Bus line for the EXT.RAM (LC
32	DB05	I/O	Data 5 Data Bus line for the EXT.RAM (LC
33	VDD	—	+5V
34	DB04	I/O	Data 4 Data Bus line for the EXT.RAM (LC
35	DB03	I/O	Data 3 Data Bus line for the EXT.RAM (LC
36	DB02	I/O	Data 2 Data Bus line for the EXT.RAM (LC
37	DB01	I/O	Data 1 (LSB) Data Bus line for the EXT.RAM (LC
38	RA01	O	ADDR01 (LSB) Address signal output for the EXT. I
39	RA02	O	ADDR02 Address signal output for the EXT.
40	RA03	O	ADDR03 Address signal output for the EXT.
41	RA04	O	ADDR04 Address signal output for the EXT.

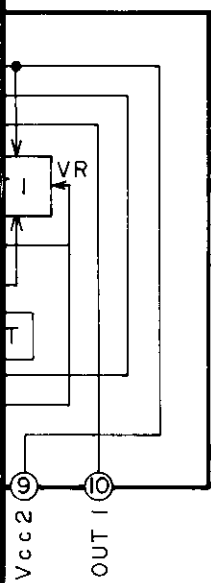

IN PUT			OUT PUT		
IN1	IN2	IN3	OUT1	OUT2	OUT3
L	L	L	L	L	L
		H			
H	L	L	H	L	OPEN
		H			
L	H	L	H	OPEN	L
		H			
H	H	L	L	L	L
		H			

Description
switching control
OFF control
and phase control
control
level control
ch guard signal output
36 MHz
CPU
CPU
U
reset
t (5V)
rface
input
of the subcode Q "L" detect error
ion output
code Q
CK (+5V)
ck "L" frame sync unlock
ta Bus line for the EXT.RAM (LC3517AS-15)
ta Bus line for the EXT.RAM (LC3517AS-15)
ta Bus line for the EXT.RAM (LC3517AS-15)
ta Bus line for the EXT.RAM (LC3517AS-15)
ta Bus line for the EXT.RAM (LC3517AS-15)
ta Bus line for the EXT.RAM (LC3517AS-15)
ta Bus line for the EXT.RAM (LC3517AS-15)
ta Bus line for the EXT.RAM (LC3517AS-15)
Address signal output for the EXT. RAM (LC3517AS-15)
Address signal output for the EXT. RAM (LC3517AS-15)
Address signal output for the EXT. RAM (LC3517AS-15)
Address signal output for the EXT. RAM (LC3517AS-15)

No.	Symbol	I/O	Description
42	RA05	O	ADDR05 Address signal output for the EXT. RAM (LC3517AS-15)
43	RA06	O	ADDR06 Address signal output for the EXT. RAM (LC3517AS-15)
44	RA07	O	ADDR07 Address signal output for the EXT. RAM (LC3517AS-15)
45	RA08	O	ADDR08 Address signal output for the EXT. RAM (LC3517AS-15)
46	RA09	O	ADDR09 Address signal output for the EXT. RAM (LC3517AS-15)
47	RA10	O	ADDR10 Address signal output for the EXT. RAM (LC3517AS-15)
48	RA11	O	ADDR11 (MSB) Address signal output for the EXT. RAM (LC3517AS-15)
49	RAWE	O	Write enable signal output "L" active
50	RACS	O	Chip select signal output "L" active
51	C4M	O	1/4X'tal OSC.output (f=4.2336MHz)
52	Vss	—	GND(0V)
53	XTAI	I	X'tal OSC. input (f=16.9344MHz)
54	XTAO	O	X'tal OSC.output (f=16.9344MHz)
55	MD1	I	Mode select input 1 0V (GND)
56	MD2	I	Mode select input 2 0V (GND)
57	MD3	I	Mode select input 3 0V (GND)
58	SLOB	I	0V (GND)
59	PSSL	I	0V (GND)
60	APTR	O	Aperture correction signal output "H" R-channel
61	APTL	O	Aperture correction signal output "H" L-channel
62	C1F1	O	NOT USE
63	C1F2	O	TP-C1F2
64	C2F1	O	NOT USE
65	C2F2	O	NOT USE
66	C2FL	O	TP-CSFL
67	C2P0	O	NOT USE
68	RFCK	O	NOT USE
69	WFCK	O	TP-WFCK
70	PLCK	O	NOT USE
71	UGFS	O	NOT USE
72	GTOP	O	NOT USE
73	VDD	—	+5V
74	RA0V	O	NOT USE
75	4CLR	O	NOT USE
76	C210	O	C210 INV.C210 (Pin 77) f=2.1168MHz
77	C210	O	NOT USE
78	DATA	O	Data output
79	WDCK	O	Wordec clock output 88.2kHz strobe
80	LRCK	O	NOT USE (L-ch, R-ch clock output)

CXA1082A

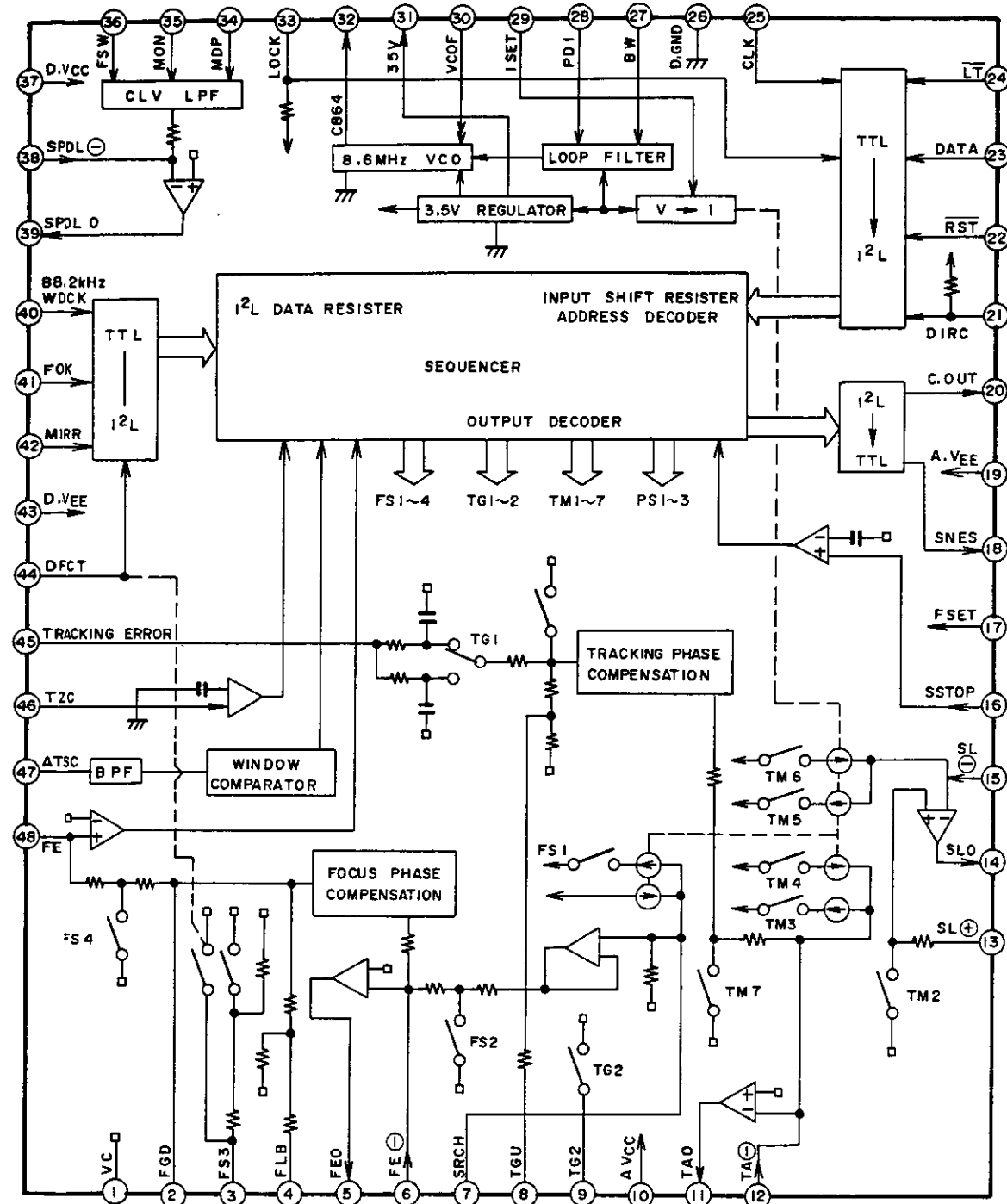

PIN NO.	SYMBOL	I/O	DESCRIPTION
1	VC	—	GND (0V)
2	FGD	—	Connect condenser for Focus servo gain control.
3	FS3	—	Focus servo gain select.
4	FLB	—	Connect condenser for Focus servo correction.
5	FE0	O	Focus drive output.
6	FE ⊖	I	FOCUS AMP. Inverting input.
7	SRCH	—	Connect condenser for Focus search wave.
8	TGU	—	Connect condenser for Tracking gain select.

PIN NO.	SYMBOL	I/O	DESCRIPTION
9	TG2	—	Connect condenser for Tracking gain select.
10	A.VCC	—	+5V
11	TA0	O	Tracking drive output.
12	TA ⊖	I	Tracking AMP. Inverting input.
13	SL ⊕	I	Slide motor non-inverting input
14	SLO	O	Slide motor drive output.
15	SL ⊖	I	Slide AMP. inverting input.
16	SSTOP	I	Not use (Holed "H" level).
17	FSET	I	Focus, Tracking compensation and CLV. LPF set up.
18	SENS	O	FZC. AS. TZC. SSTOP and $\overline{\text{BUSY}}$ output.
19	A. VEE	—	-5V.
20	C.OUT	O	Track count signal output.
21	DIRC	—	Not used
22	RST	I	RESET Input.
23	DATA	I	Data signal input from CPU.
24	LT	I	Lutch signal input from CPU.
25	CLK	I	Clock signal input from CPU.
26	D.GND	—	GND (0V).
27	BW	I	Connect condenser for Loop filter.
28	PDI	I	PDO signal from IC3 CXD1135Q (Pin 11).
29	ISET	I	Focus search, Track jump and slide kick current input.
30	VCOF	I	Connect register for VCO frequency.
31	3.5V	O	+3.5V REG. output.
32	C864	O	8.64 MHz VCO output.
33	LOCK	I	LOCK signal from IC3 CXD1135Q (Pin 7)
34	MDP	I	MDP signal from IC3 CXD1135 (Pin 3)
35	MON	I	MON signal from IC3 CXD1135 (Pin 2)
36	FSW	I	Connect condenser for CLV servo error signal LPF.
37	DVcc	—	+5V
38	SPDL ⊖	I	Spindle drive AMP. inverting input.
39	SPDLO	I	Spindle drive output.
40	WDCK	I	Auto sequence clock signal input (88.2 kHz)
41	FOK	I	Focus OK signal input.
42	MIRR	I	MIRR signal input.
43	D.VEE	—	-5V
44	DFCT	I	Defect signal input "H" active.
45	TE	I	Tracking error signal input.
46	TZC	I	Tracking zero cross comparator input.
47	ATSC	I	ATSC detect window comparator input.
48	FE	I	Focus error signal input.

LB1240

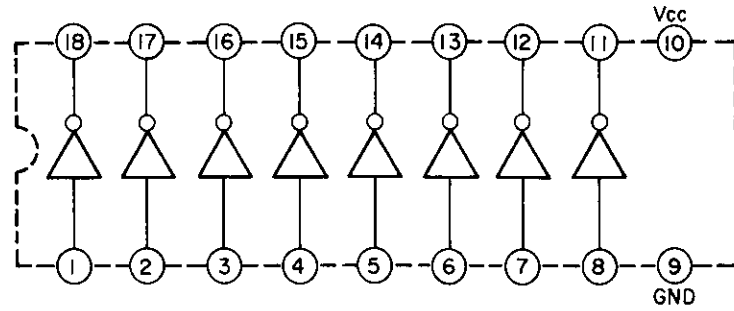

LC3517AS-15

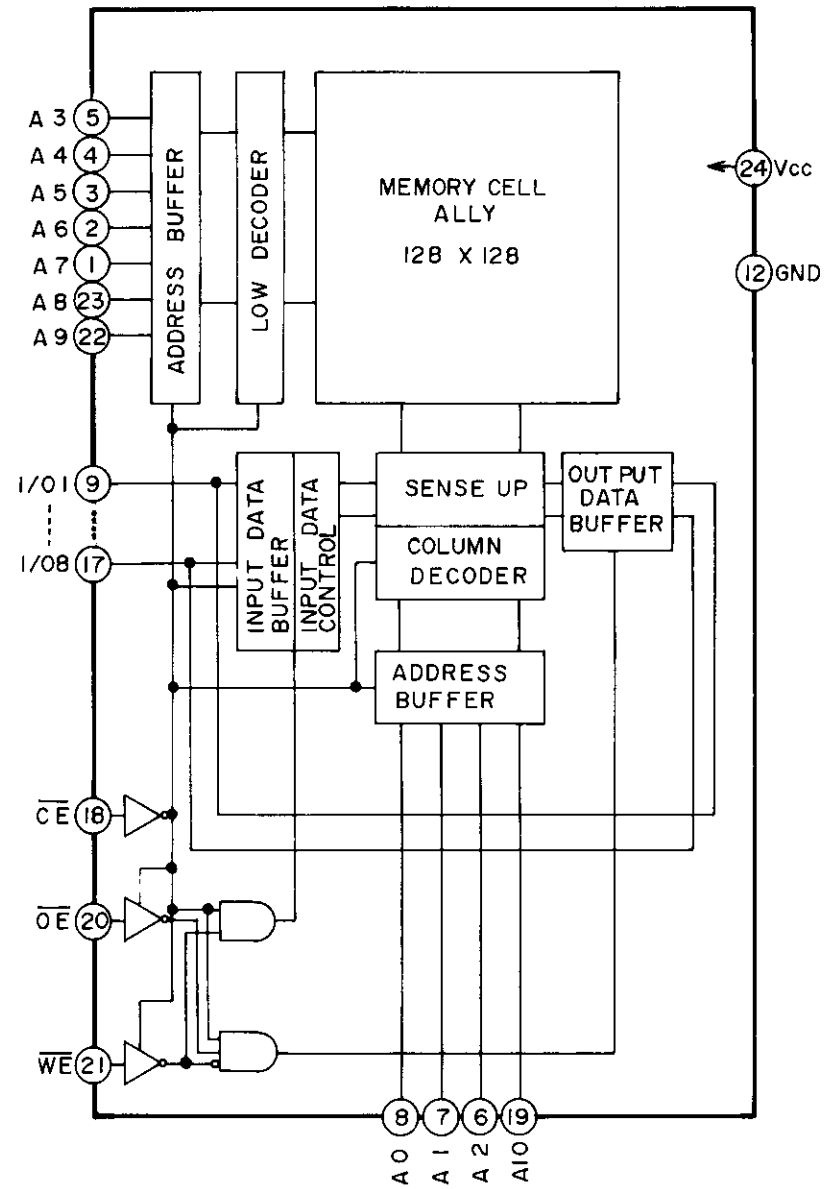

IC M50747-433SP

PIN NO.	SYMBOL	I/O	FUNCTION
1	V _{cc}	—	+5V
2	RST	O	Reset control for external LSI.
3	—	—	Not used
4	—	—	Not used
5	—	—	Not used
6	—	—	Not used
7	L.M GAIN	O	Speed control when sled moving inward direction, "L" = Farst
8	SQCK	O	Reading clock output for sub cord data.
9	TEST	O	Test terminal
10	CRCF	I	Error check data input of sub cord.
11	SUBQ	I	Sub cord data input
12	—	—	Not used
13	—	—	Not used
14	GFS	I	PLL Lock Detection input H: PLL Lock
15	SENS	I	Auto sequence end detection input H: Auto sequence end
16	FOK	—	Focus Lock Detection input H: Focus Lock
17	—	—	Not used
18	—	—	Not used
19	CLK	O	Clock output for external LSI.
20	DATA	O	Data output for external LSI 8 bit serial data.
21	LT	O	Latch output for external LSI.
22	CNTR	I	For cut the 1/256 pulse of track, when sled moving largely.
23	INT ₂	—	Not used
24	L/D ON	—	Laser diode ON/OFF control.
25	—	—	Not used
26	SCOR	I	Input of sub cord sync. S0 + S1.
27	CNV _{ss}	—	GND
28	RESET	I	Reset input
29	X IN	I	Clock input 8.4672 MHz
30	X OUT	O	Not used
31	—	—	Not used
32	V _{ss}	—	GND
33	—	—	Not used
34	—	—	Not used
35	—	—	Not used
36	ID5	I	} Key Data input from Input expander IC HD6805SO
37	ID4	I	
38	ID3	I	
39	ID2	I	

PIN NO.	SYMBOL	I/O	FUNCTION	
40	ID1	I	Key Data input from Input expander IC HD 6805SO	
41	DE EMP	O	De-emphasis ON/OFF control output	
42	MUTG.	O	Mute ON/OFF control output	
43	L.D GAIN	O	Loading motor speed control output (L = Normal speed, H: Low speed)	
44	M3	O	Loading and clamp motor control logic output for IC BA6247N	
45	M2	O		
46	M1	O		
47	SYNC	O	Display data transfer for Display MI-CON LC 6568H-3425	
48	SCK	O		
49	DATA	O		
50	DISPLAY ON/OFF	O		
51	—	—	Not used	
52	—	—	Not used	
53	—	—	Not used	
54	—	—	Not used	
55	—	—	Not used	
56	—	—	Not used	
57	—	—	Not used	
58	TEST MODE	I	Test mode select input.	L: Test mode select.
59	L.M.I	I	Linear motor moving direction input	H: When moving to inward.
60	TIMER	I	Timer start select input	H: Timer start
61	DOWN	I	Clamper down detection input	L: Down
62	UP	I	Clamper up detection input	L: Up
63	CLOSE	I	Tray close detection input	L: Close
64	OPEN	I	Tray up detection input	L: Up

PCM-56PJ 16 BIT D/A CONVERTER

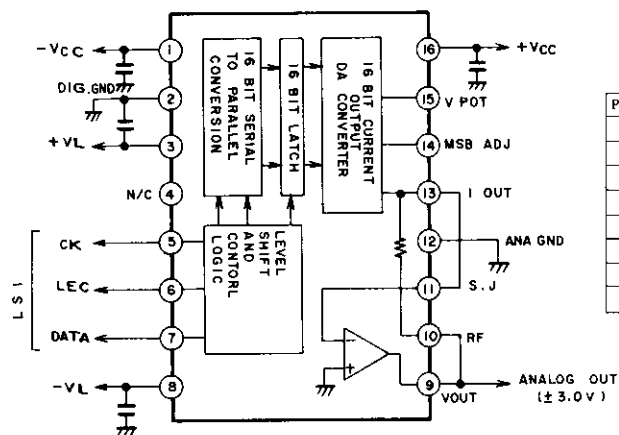

PIN NO.	FUNCTION	PIN NO.	FUNCTION
1	-Vcc	16	+Vcc
2	DIG GND	15	VPOT
3	+VL	14	MSB ADJ
4	N/C	13	I OUT
5	CK	12	ANA GND
6	LEC	11	S.J
7	DATA	10	RF
8	-VL	9	Vout

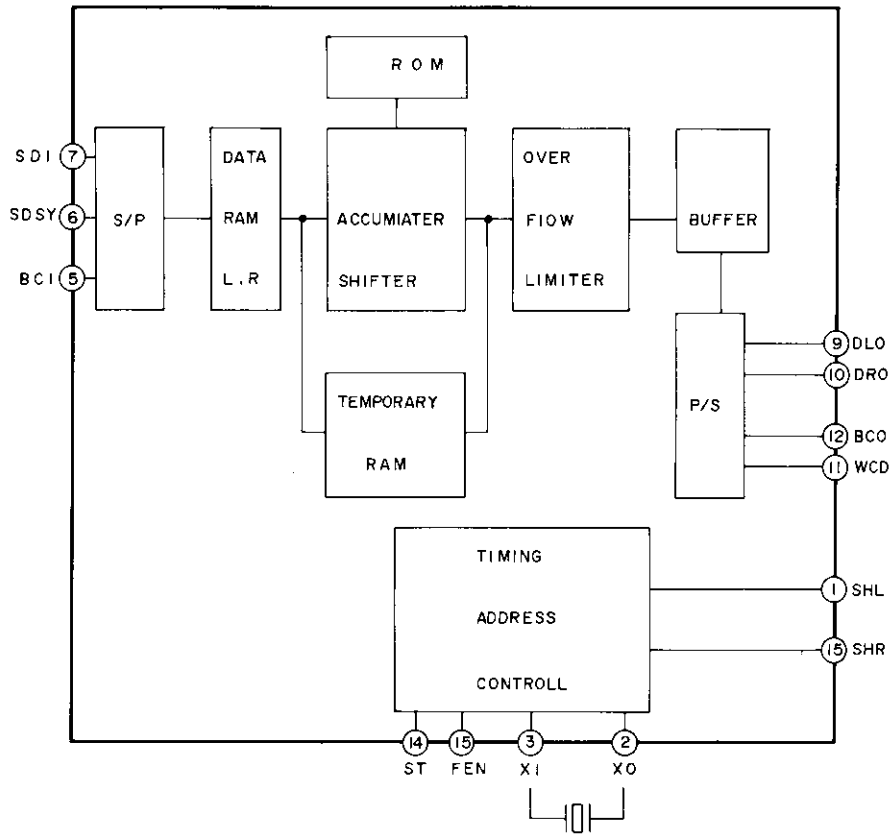

Pin No.	Symbol	I/O	Function
1	SHL	O	1 DAC (ST="L") use: L channel diglitcher signal output. 2 DAC (ST="H") use: L/R channels diglitcher signal output.
2	XO	O	Terminal for X'tal when using the internal clock osc.
3	XI	I	Terminal for X'tal when using the internal clock osc or Input terminal of external clock.
4	Vdd2		Power Supply (+5V) for X'tal OSC and Deglitcher.
5	BCI	I	Input the bit clock of the Input data.
6	SDSY	I	Difference Between L and R channel and provided input timing of data.
7	SDI	I	Data input terminal.
8	Vdd1		Power Supply (+5V) for digital signal.
9	DLO	O	1 DAC (ST="L") use: L, R channel data output 2 DAC (ST="H") use: L channel data output.
10	DRO	O	R channel data output.
11	WCO	O	Word clock of output data DLO and DRO.
12	BCO	O	Output terminal for bit clock of output data and system clock of SPC2,3.
13	Vss		Ground terminal
14	ST	I	Select control of 1DAC or 2DAC ("L"=1DAC, "H"=2DAC).
15	FEN	I	Select control of system clock ("L"=196fs, "H"=192fs)
16	SHR	O	Deglitcher signal of R channel when 1DAC is selected.