

Service Manual

TVR 706

SPECIFICATION

SYSTEM : PAL-B/G

----- TV SECTION -----

CHANNEL COVERAGE VHF LOW : 2 - 4 CH. CH.
VHF HIGH : 5 - 12 CH.
UHF : 21 - 69 CH.
FREQUENCY RANGE VHF LOW : 47 - 68 MHz
VHF HIGH : 174 - 230 MHz
UHF : 470 - 862 MHz
FREQUENCY VIDEO IF : 38.9 MHz
SOUND IF : 33.4 MHz
VISION / SOUND SEPARATION : 5.5 MHz
SENSITIVITY VHF LOW : 32 uV
VHF HIGH : 45 uV
UHF : 45 uV
SCANNING LINES : 625 LINES
HORIZONTAL : 15625 Hz
VERTICAL : 50 Hz
OUTPUT POWER MAXIMUM : 900 mW
10% THD : 600 mW
C R T . : 5.5" DIAGONAL, 55 DEGREES DEFLECTION ANGLE
SPEAKER : 3½" 8 Ohm 2 W
ANTENNAL EXTERNAL : 75 Ohm
POWER CONSUMPTION : AC 35 WATTS

----- RADIO SECTION -----

FREQUENCY RANGE AM : 515 - 1630 KHz
FM : 87.25 - 108.5 MHz
IF AM : 465 KHz
FM : 10.7 MHz
SENSITIVITY AM : 250 uV/m
FM : 10 uV
ANTENNAL INTERNAL : ROD ANTENNAL

CONTROL LOCATION

BATTERY BOX

1. BATTERY BOX EJECT BUTTON
2. BATTERY COVER
3. DC PLUG.

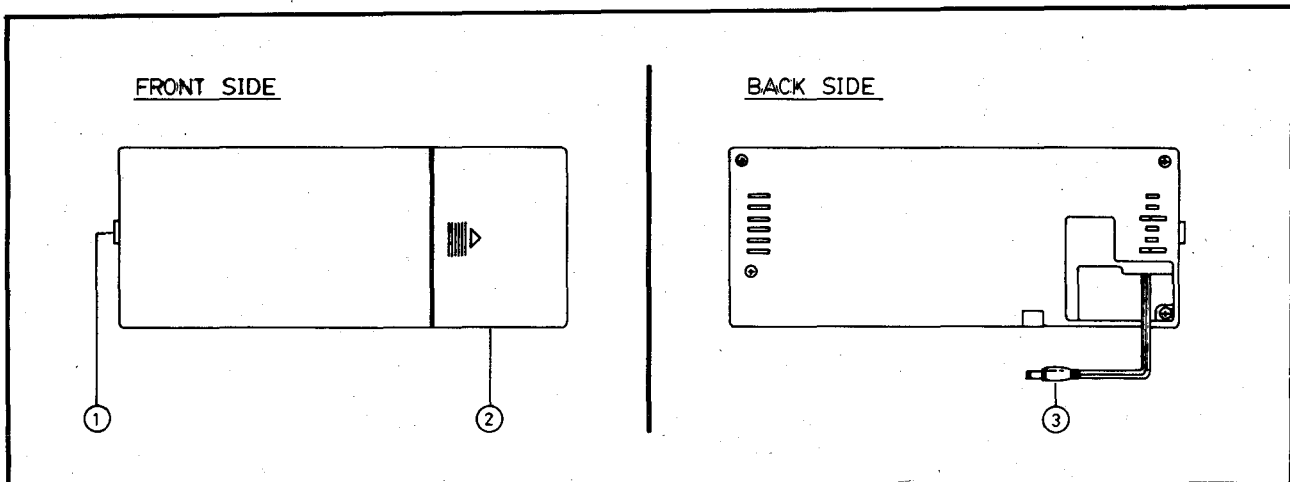

MOUNTING BRACKET FEATURES

1. MOUNTING SCREW HOLES
2. SWIVEL INSERT
3. TV/RADIO RETAINING RAILS
4. LOCKING POSITIONS (4)

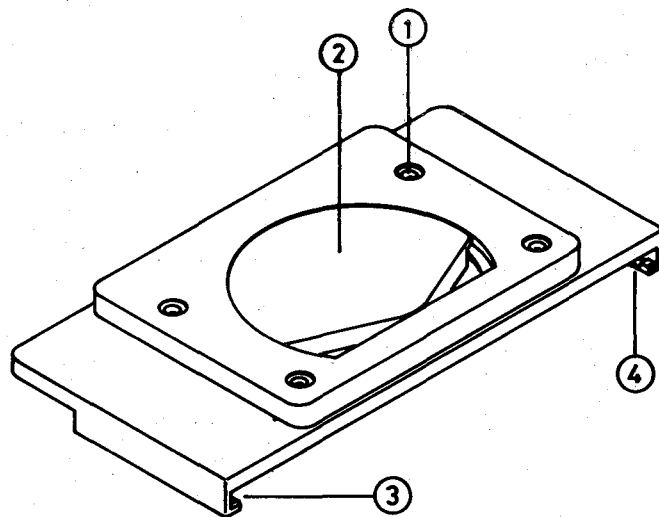

CONTROL LOCATION :

1. 6" 55° IN-LINE GUN COLOR TV SCREEN
2. TV DIAL SCALE
3. RADIO DIAL SCALE
4. LED CLOCK DISPLAY
5. CLOCK CONTROL BUTTON
6. SENSOR SNOOZE
7. RADIO TUNING
8. TV TUNING
9. DIMMER SWITCH
10. POWER OFF/ON/AUTO SWITCH
11. VL/VH/UHF TV BAND SELECTOR
12. TV/RADIO FUNCTION SWITCH
13. VOLUME CONTROL
14. BAND SELECTOR SWITCH
15. HANDLE
16. DEGAUSSING PUSH BUTTON
17. VERTICAL HOLD CONTROL
18. CONTRAST CONTROL
19. BRIGHTNESS CONTROL
20. COLOR CONTROL
21. EARPHONE JACK
22. TELESCOPIC ANTENNA
23. BATTERY COVER
24. AC LINE CORD
25. DC 12V - 15V INPUT JACK
26. 75 Ohm EXTERNAL ANTENNA TERMINAL

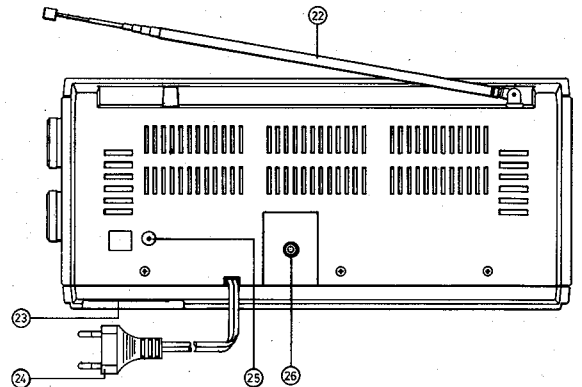
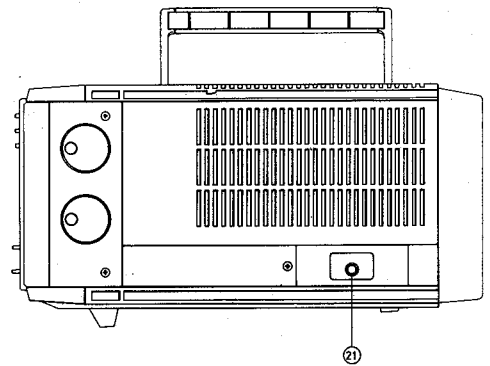
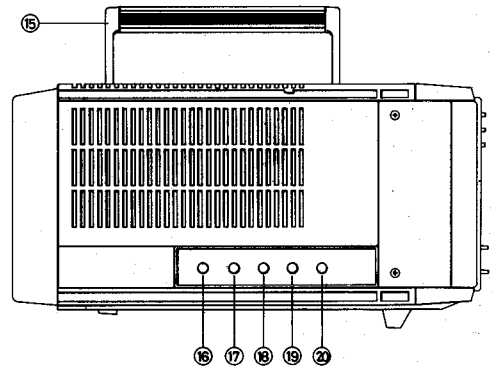
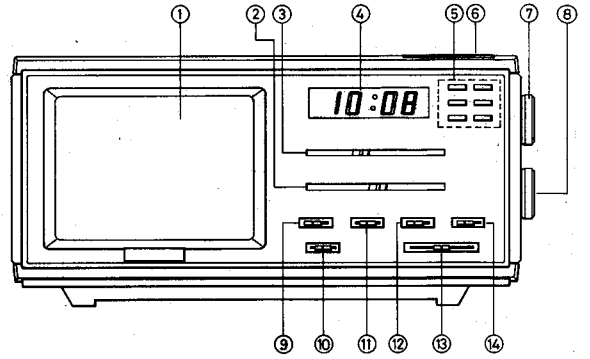

BLOCK DIAGRAM

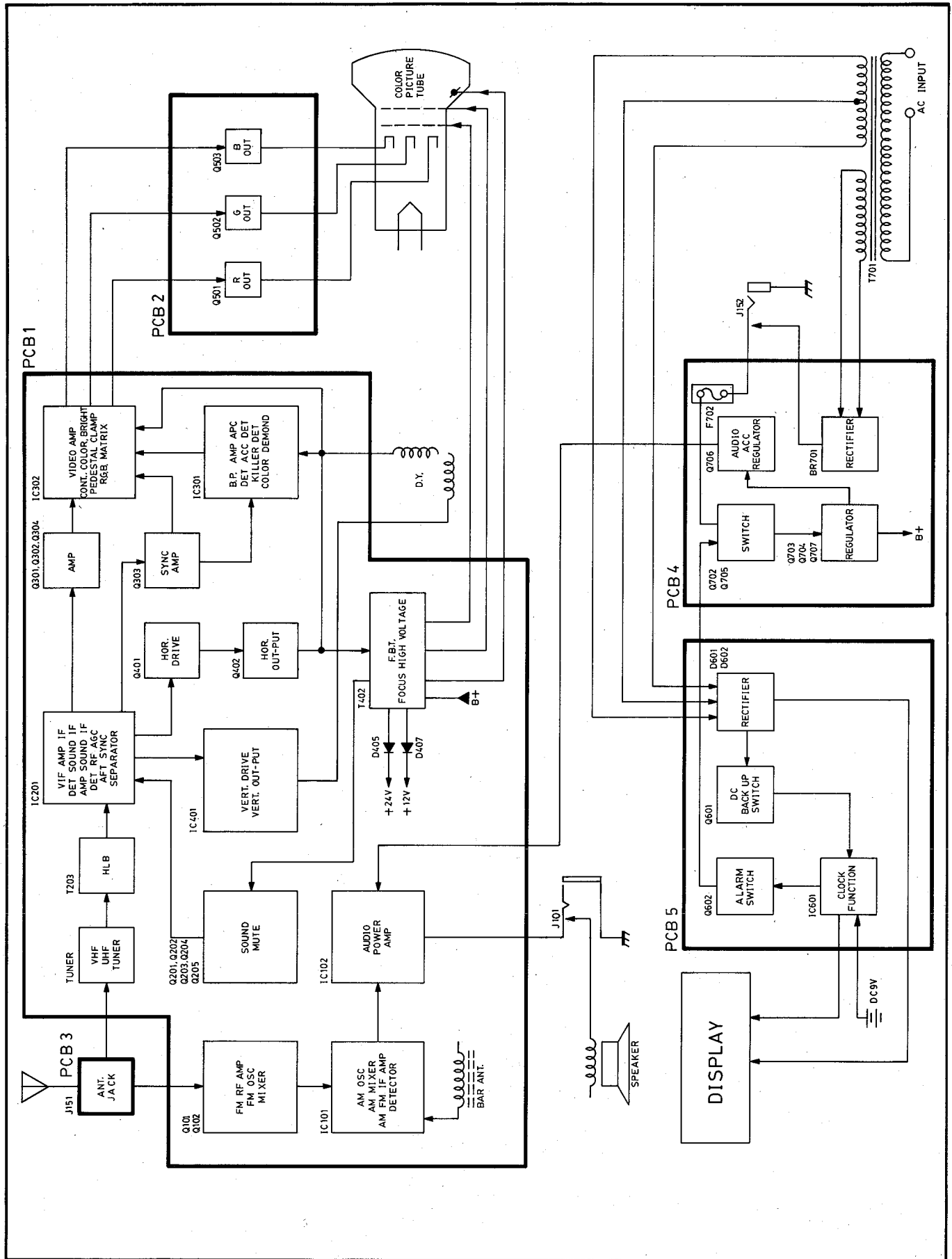

ALIGNMENT INSTRUCTION

I. PLEASE READ BEFORE ATTEMPTING SERVICE

1. Do not connect any antenna plug directly to the tuner socket and do not connect any equipments directly to the TV chassis, otherwise it may be burnt out the TV or equipment , except an isolation transformer is used for main power source of the TV sets.
2. Never disconnect any leads while receiver is in operation.
3. Disconnect all power before attempting any repairs.
4. Do not short any portion of the circuits while power is on.
5. For reason of safety, all parts replaced should be identical, (For parts and part numbers see PARTS LIST).
6. Before alignment the set must be pre-heated for 30 minutes or more and erase magnetism thoroughly from CRT front chassis frame by erase coil.

II. TEST EQUIPMENT

1. VIF Sweep Generator
2. SIF Sweep Generator
3. Continuous Waveform Generator
4. Color Bar / Dot / Cross Hatch Generator
5. Philips Pattern Generator
6. DC Power Supply (24V)
7. Oscilloscope
8. Vacuum Tube Volt Meter
9. Volt Ohm Meter
10. High Voltage Meter
11. Ampere Meter (0.5 Class, DC 3mA Max.)
12. Frequency Counter
13. Demagnetizing Coil
14. DC Power Supply (12V)

III. VIF ALIGNMENT

A. PREPARATION STEP (SEE FIG. 2)

1. Turn the RF AGC control fully counter clockwise.
2. Supply AGC bias voltage to TP 208 (SEE FIG. 1).

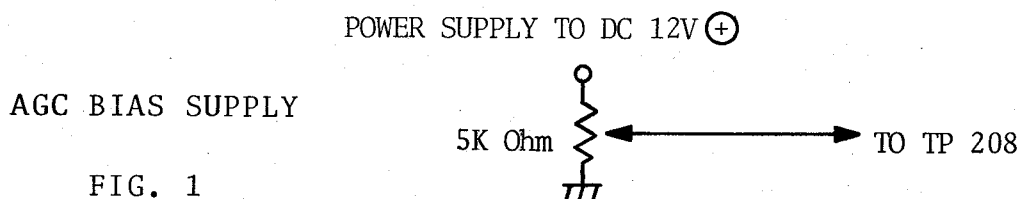

3. Connect output lead of VIF Sweep Generator to tuner test point and tuner body.
4. Connect lead of FROM DET between TP 207 and TP 202.
5. Connect resistor jumper (100 Ohm) between TP 203 and TP 204.
6. Supply DC 24V to (+) lead of D 405.
7. Supply DC 12V to (+) lead of D 407.

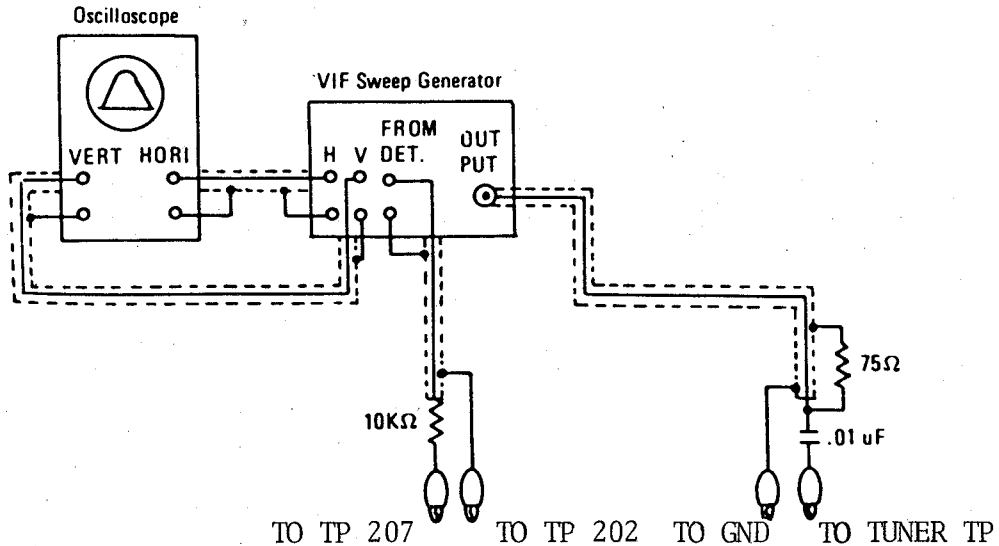

FIG. 2

B. ALIGNMENT STEP

1. Adjust AGC bias voltage for maximum amplitude of waveform.
2. Adjust the level of Sweep Generator to achieve 1V p-p output.
3. Increase the output level of Sweep Generator in 20 dB.
4. Adjust AGC bias voltage to achieve 1Vp-p output (on Oscilloscope).
5. Adjust core of T 203 (C,D,E,F Core) and tuner converter coil to obtain the waveform as in FIG. 3.
6. Increase the output level of Sweep Generator in 10 dB, adjust (A) core of T 203 to obtain the waveform as in FIG. 4.

T 203

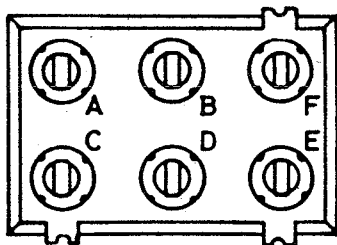

FIG. 4

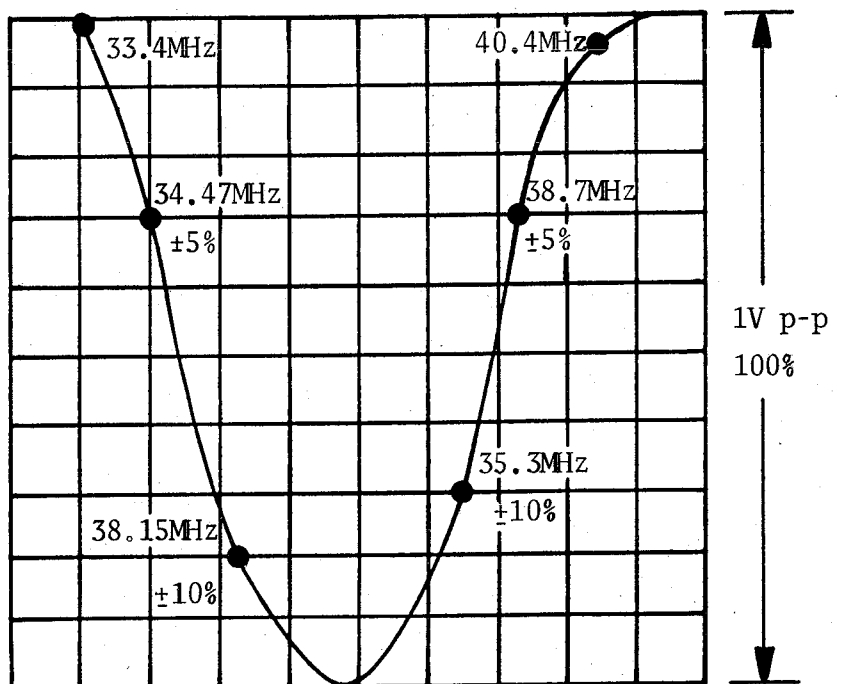
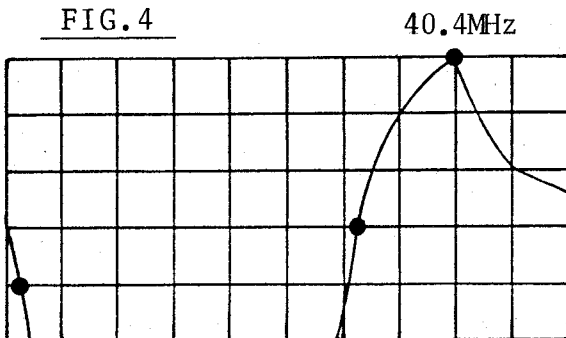

FIG. 3

IV. SIF ALIGNMENT

A. PREPARATION STEP (SEE FIG.5).

1. Connect output lead of SIF Sweep Generator between TP 207 and ground.
2. Connect lead of FROM DET between TP 201 and ground.
3. Supply DC 24V to lead of D 405.

FIG.5

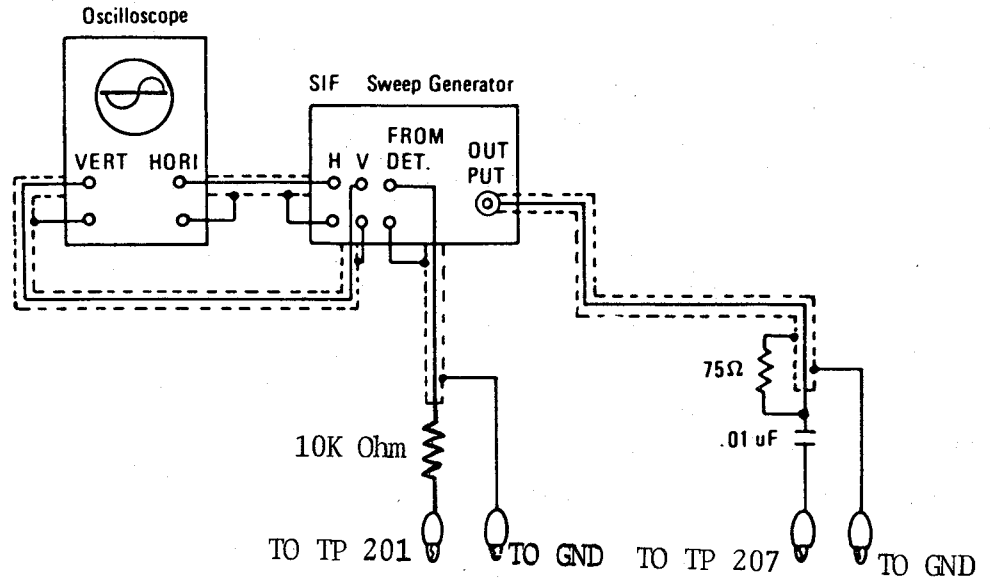

B. ALIGNMENT STEP

1. Adjust output of Sweep Generator to achieve 4V p-p between markers of 100 KHz.
2. Adjust T 204 so that sound carrier is centered as in FIG. 6.
3. Confirm the waveform as in FIG.6.

FIG.6

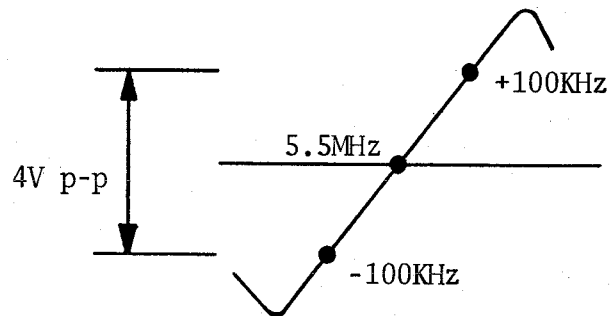

V. TANK COIL ALIGNMENT

A. PREPARATION STEP

1. Remove the damping resistor (100 Ohm) at TP 203, TP 204.
2. Connect output lead of Continuous Waveform Generator to tuner test point TP, and tuner case.
3. Connect Oscilloscope (DC level) to TP 209.
4. Supply DC +24V to lead of D 405.
5. Supply DC +12V to lead of D 407.

B. ALIGNMENT STEP

1. Set the output carrier of Continuous Waveform Generator to picture carrier frequency 38.9 MHz, Input level 80 dBuV to 100 dBuV.
2. Adjust T 202 for minimum DC. (FIG.7).

NOTE :

1. RF AGC control (VR 203) is set at middle position.
2. While feeding signal increase signal of 5 dB from specified level, RF AGC control (VR 203) is set at where level on the Oscilloscope does not go into saturation range.

DC range vertical sensitivity 1V/cm

FIG.7

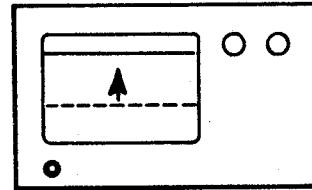

VI. AFC ALIGNMENT

A. PREPARATION STEP (SEE FIG. 8)

1. Connect output lead of Continuous Waveform Generator to tuner test point TP, and tuner case.
2. Connect vacuum tube voltmeter or digital volt meter to TP 206.
3. Supply DC +24V to lead of D 405.
4. Supply DC +12V to lead of D 407.

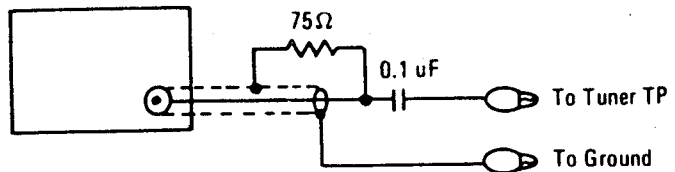

FIG.8

B. ALIGNMENT STEP

1. Set the output of Continuous Waveform Generator to picture carrier frequency 38.9 MHz.
2. Adjust T 201 to the reading of 6.7 + 0.2V DC.
3. Vary the frequency of Continuous Waveform Generator in ± 100 KHz and observe the voltage of Vacuum Tube Volt Meter or digital volt meter as follow. :
+ 100 KHz Less than 2.5V
- 100 KHz More than 8 V

NOTE :

1. RF AGC control (VR 203) is set at middle position.
2. Input level, 80 dBuV to 100 dBuV

VII. CHROMA ALIGNMENT

A. PREPARATION STEP (SEE FIG. 9)

1. Supply AGC bias voltage to TP 208 (See FIG. 1).
2. Supply DC 24V to ⊕ lead wire of D 405.
3. Supply DC 12V to ⊕ lead wire of D 407.
4. Connect resistor jumper (100 Ohm) between TP 203 and TP 204.
5. Connect Pin 2,3 of IC 301 by jumper wire.
6. Connect output lead of chroma Sweep Generator to tuner test point TP.
7. Connect the lead of detector TP 302 and TP301.
8. Set the select switch of Sweep Generator to modulation position.

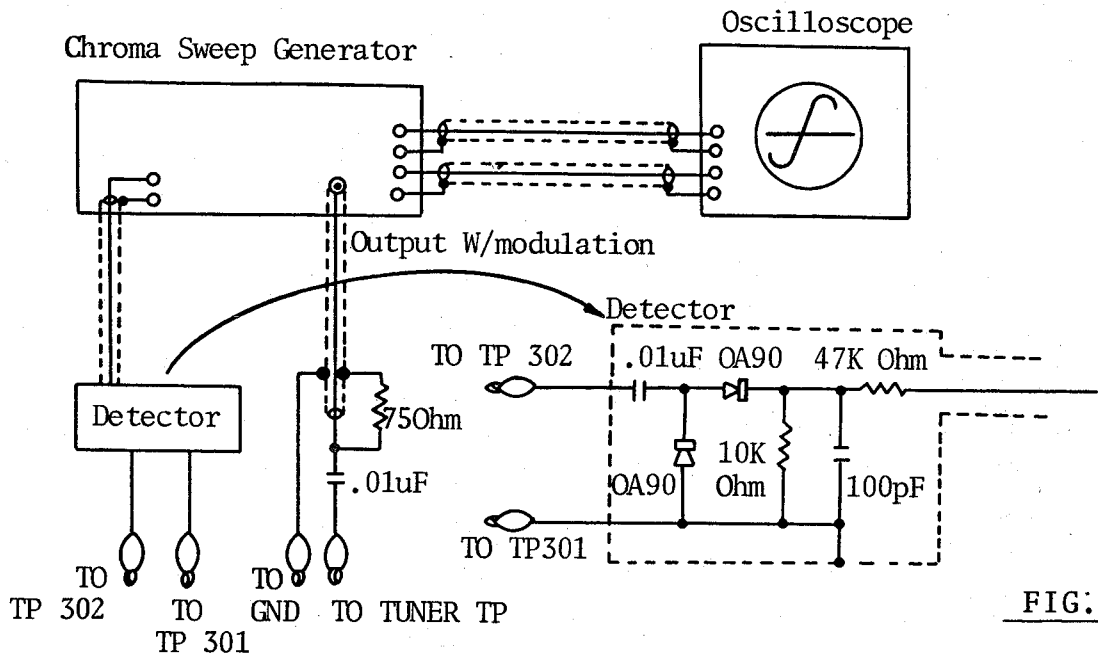

FIG. 9

B. ALIGNMENT STEP

1. Adjust IF AGC bias voltage to obtain the maximum output.
2. Adjust output level of Chroma Sweep Generator to achieve 0.5V p-p at output of detector.
3. Adjust T 301 to obtain the waveform as in FIG. 10.

Input level : -20 to 0 dB

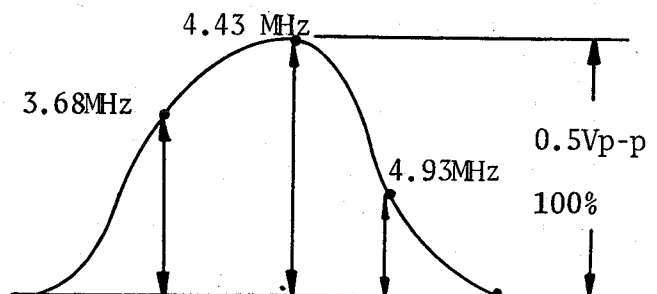

FIG. 10

VIII. B+ ADJUSTMENT

1. Connect the Digital Volt Meter to pin 8 of T 402.
2. Adjust Semi-Fixed Resistor VR 701 until meter reading DC 9.9V.

IX. HORIZONTAL CIRCUIT ALIGNMENT

1. Set the CHANNEL SELECTOR to no signal channel.
2. Connect the frequency counter between R 233 and ground.
3. Adjust H-HOLD control (VR 204) to the reading of 15.625 KHz.

X. VERTICAL CIRCUIT ADJUSTMENT

1. Set V-HOLD control (VR 105) to middle position.
2. Set the CHANNEL SELECTOR to no signal channel.
3. Connect the frequency counter between V-deflection Yoke and ground.
4. Adjust SUB-V HOLD (VR 207) to the reading of 50 Hz.
5. Receive Philips Pattern.
6. Adjust V-HEIGHT control to obtain a normal picture.

XI. WHITE BALANCE ADJUSTMENT

1. Set the SCREEN control (on the FBT) to middle position.
2. Turn the red, and blue LOW-LIGHT controls (VR 502, VR 504) to middle position, and turn the DRIVE controls (VR 501, VR 503) to middle position.
3. Receive a black and white picture signal.
4. Turn the SCREEN control (on the FBT) to minimum position.
5. Set the SUB-BRIGHTNESS control (VR 401) to middle position, then turn the CONTRAST control (VR 303) and COLOR control (VR304) fully counterclockwise.
6. Set the SERVICE switch (S301) to "SERVICE" position.
7. Connect Volt meter between (R510) and ground, and adjust BRIGHTNESS control (VR 302) to the reading of DC 75V. If DC 75V can not be obtained, adjust the SUB-BRIGHTNESS control (VR 401).
8. Slowly turn the SCREEN control clockwise to the point where the green color just illuminates.
9. The LOW-LIGHT control volume corresponded to the color appeared on the CRT, leaves as it is, and need no further adjustment for this control volume. Turn the rest of LOW-LIGHT control volumes toward clockwise to get white horizontal line on CRT.
10. Reset the SERVICE switch (S301) to "NORMAL" position and turn BRIGHTNESS control (VR 302) to middle position.
11. Adjust red and blue DRIVE controls (VR 501, VR 503) to obtain a uniform white raster.

12. Check the black and white picture detail for proper black and white rendition (no coloration) from low-lights to high-lights and all brightness levels for proper tracking.

Proper tracking at all brightness levels can be obtained when the SCREEN control, LOW-LIGHT controls and DRIVE controls are properly adjusted. If the results are unsatisfactory, repeat from the beginning.

XII. FOCUS ADJUSTMENT

1. Set CONTRAST control to maximum position and BRIGHTNESS control to middle position.
2. Adjust FOCUS control (on the FBT) to obtain a sharpest and clearest picture on the CRT.

XIII. RF AGC ALIGNMENT

1. Receive the signal of UHF High Channel.
2. Set the input field strength in $60 \text{ dB} \pm 3 \text{ dB}$
3. Adjust RF AGC Control VR 203 to the point where noise is disappeared.
4. Set the input field strength in 90 dB. Do not overload.

XIV. COLOR DEMODULATOR ALIGNMENT, DELAY LINE ALIGNMENT

1. Receive Philips Pattern.
2. Set the "SERVICE" switch (S 301) to "SERVICE" position.
3. Set COLOR control (VR 304) to maximum position.
4. Connect Oscilloscope to Pin 9 of IC 302 (B-Out).
5. Adjust CT 301 to obtain the waveform as in FIG. 11.
6. Adjust T 302, T 303 and VR 301 to obtain the waveform as in FIG. 11.

NOTE : Cores of T 302 and T 303 should be adjusted equal height of core.

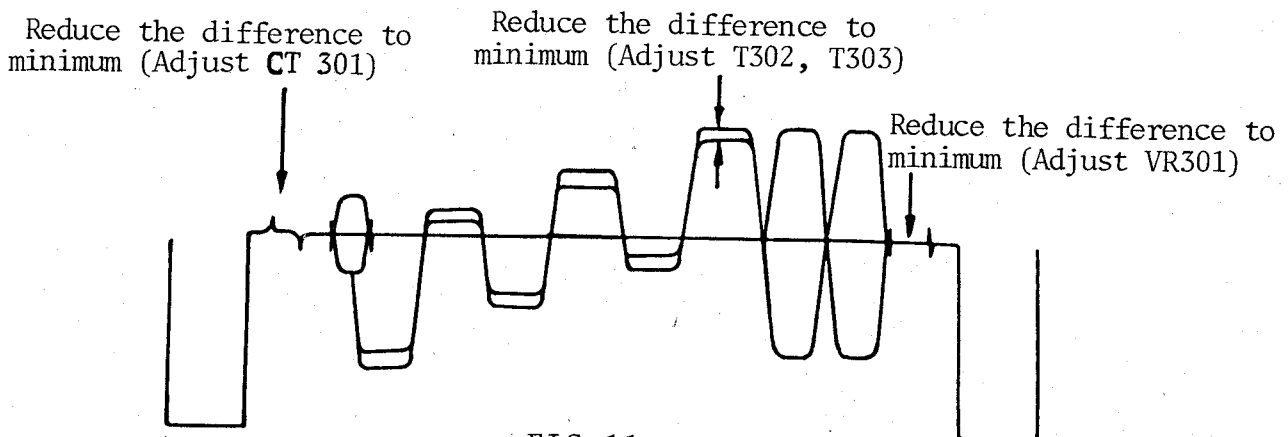

XV. SUB-BRIGHTNESS ALIGNMENT

1. Connect the negative side of DC ampere meter (3mA full scale range) to TP401 and the positive side to TP 402.
2. Receive Philips Pattern.
3. Set controls as follows :
BRIGHTNESS Control MAX.Position
CONTRAST Control MAX.Position
COLOR Control MAX.Position
4. Adjust SUB-BRIGHTNESS control (VR 401) to the reading of 250 uA.

XVI. COLOR PURITY ADJUSTMENT (SEE FIG. 12).

BEFORE ALL ADJUSTMENT DESCRIBED BELOW ARE ATTEMPTED, V-HOLD, H-HOLD, V-HIGH, B+ VOLTAGE AND FOCUSING ADJUSTMENT MUST BE COMPLETED.

1. Place the TV receiver facing NORTH or SOUTH.
2. Plug in TV receiver and turn it ON.
3. Operate the TV receiver over 30 minutes.
4. Fully degauss the TV receiver by using an external degaussing coil.
5. Receive a crosshatch pattern and adjust the static convergence control roughly.
6. Loosen the clamp screw of the deflection yoke and pull the deflection yoke toward you.
7. Fully turn the red and blue low light controls (VR 502, VR 504) counterclockwise.
8. Adjust the purity magnets so that green field is obtained at the center of the screen.
9. Slowly push the deflection yoke toward bell of CRT and set it where a uniform green field is obtained.
10. Tighten the clamp screw of the deflection yoke.

XVII. CONVERGENCE ADJUSTMENT (SEE FIG. 12).

1. Receive a dotted pattern.
2. Unfix the convergence magnet clamper and align red with blue dots at the center of the screen by rotating (R, B) static convergence magnets.
3. Align red/blue with green dots at the center of the screen by rotating (RB-G) static convergence magnet.
4. Fix the convergence magnet by turning the clamper.
5. Remove the DY wedges and slightly tilt the deflection yoke horizontally and vertically to obtain the good overall convergence,
6. Fix the deflection yoke by wedges.
7. If purity error is found, follow "Purity Adjustment" instructions :

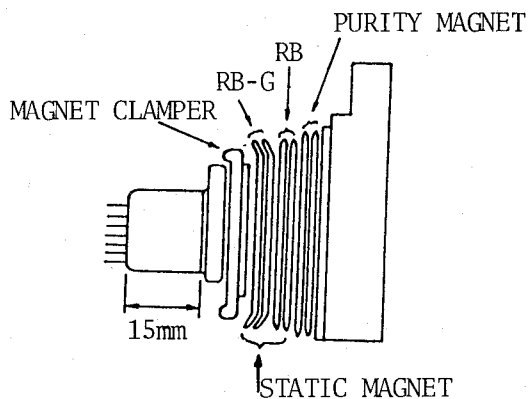

ALIGNMENT INSTRUCTION
AM SECTION

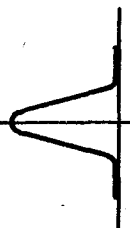
STEP	ALIGNMENT FREQ.	TEST EQUIPMENT	SIGNAL - IN	SIGNAL - OUT	ADJUST	REMARK
1	IF 465 KHz	(1) AM IF Sweep Gen. with Loop Ant. (2) Alignment Oscilloscope. (3) Power Supply.	Let The MW Ant. Coil Close to The Gen. Antenna	Take Out The Signal From TP101 Point.	Adjust T102/T104 to Get Max. Output At 465 KHz. 	(1) Band Sw. in MW Position. (2) Tune PVC to High End.
2	1635 KHz	(1) AM Sweep Gen. With Ant. (2) Alignment Oscilloscope. (3) Power Supply.	Same As Step (1)	Same As Step (1)	Adjust VC103 to Get Max. Output At 1635 KHz.	Same as Step (1).
3	515 KHz	Same As Step (2)	Same As Step (1)	Same As Step (1)	Adjust T101 to Get Max. Output At 515 KHz.	Tune PVC to Low End.
4	Repeat Step 2,3 Until No Further Improvement Can Be Made.					
5	1400 KHz	Same As Step (2)	Same As Step (1)	Same As Step (1)	Adjust VC107 to Get Max. Output at 1400 KHz.	Tune PVC to 1400 KHz
6	600 KHz	Same As Step (2)	Same As Step (1)	Same As Step (1)	Adjust L104 to Get Max. Output At 600 KHz	Tune PVC to 600 KHz.
7	Repeat Step 5,6 And Then Step 2,3,5,6, Until No Further Improvement Can Be Made.					

ALIGNMENT INSTRUCTION
FM SECTION

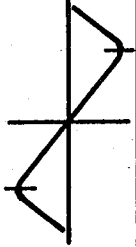
STEP	ALIGNMENT FREQ.	TEST EQUIPMENT	SIGNAL - IN	SIGNAL - OUT	ADJUST	REMARKS
1	IF 10.7 MHz	(1) FM IF Sweep Generator. (2) Alignment Oscilloscope (3) Power Supply.	Inject The IF Sweep Signal Through .01 UF Capacitor to C101 (Ant) Point.	Signal Are Taken Out From TP101 Point	Adjust T103/ T105 and Repeat to Get Best 'S' Curve With Center at 10.7 MHz. 10.7 MHz 	(1) Band Sw. in FM Position. (2) Tune PVC to High End.
2	108.5 MHz	(1) FM RF Sweep Generator. (2) Alignment Oscilloscope. (3) Power Supply.	Inject The RF Signal Directly To External Ant. Terminal	Same As Step (1)	Adjust VC105 to Get Max. Output.	Same As Step (1)
3	87.3 MHz	Same AS Step (2)	Same As Step (2)	Same As Step (1)	Adjust L105 to Get Max. Output.	Tune PVC to Low End.
4	Repeat Step 2,3 Until No Further Improvement Can Be Made.					
5	106 MHz	Same as Step (2)	Same AS Step (2)	Same As Step (1)	Adjust VC101 to Get Max. Output.	Tune PVC to 106 MHz
6	90 MHz	Same as Step (2)	Same As Step (2)	Same As Step (1)	Adjust L103 to Get Max. Output.	Tune PVC to 90 MHz
7	Repeat Step 5,6 And Then Step 2,3,5,6, Until No Further Improvement Can Be Made.					

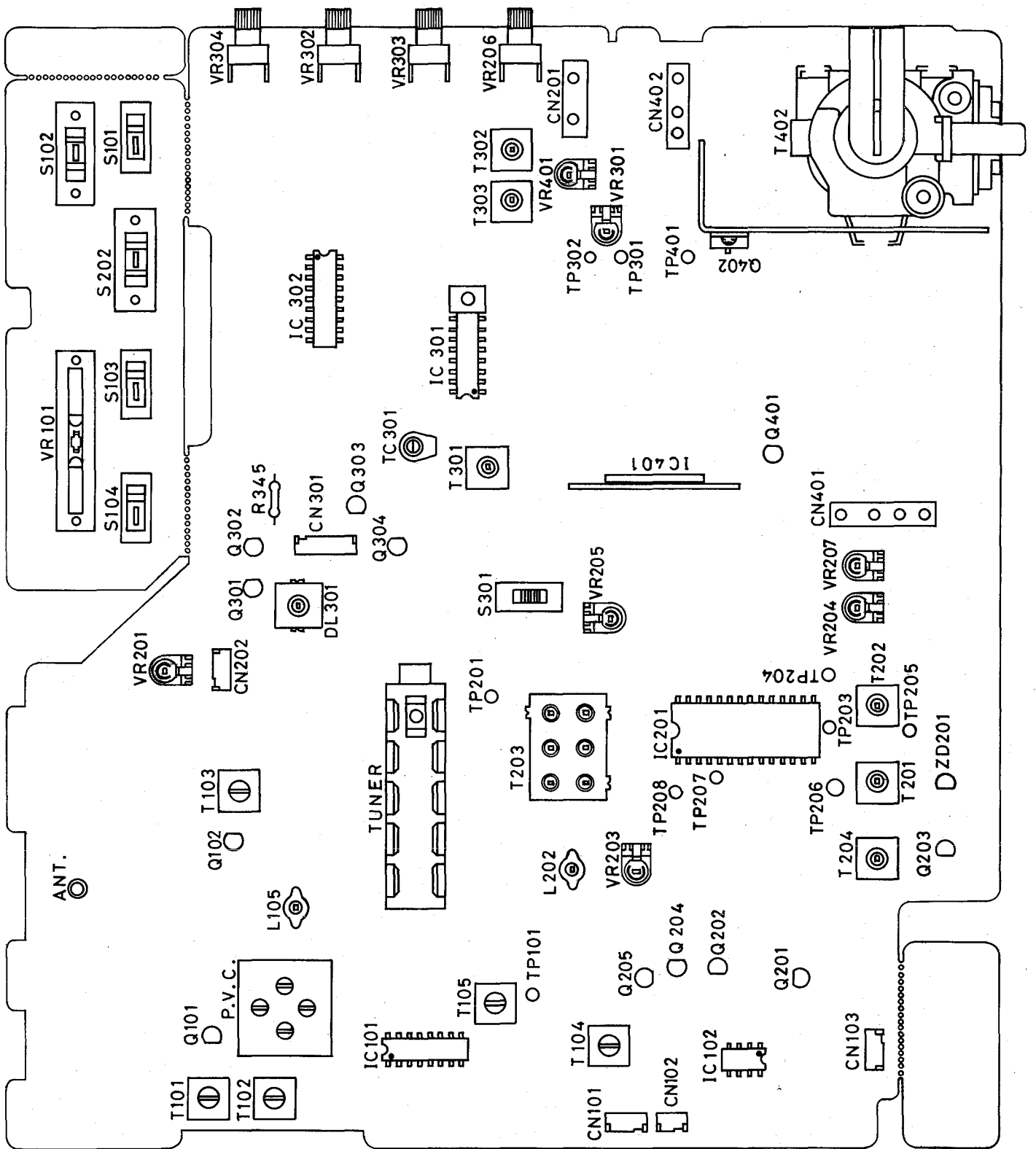

ALIGNMENT POINT OF CRT BOARD

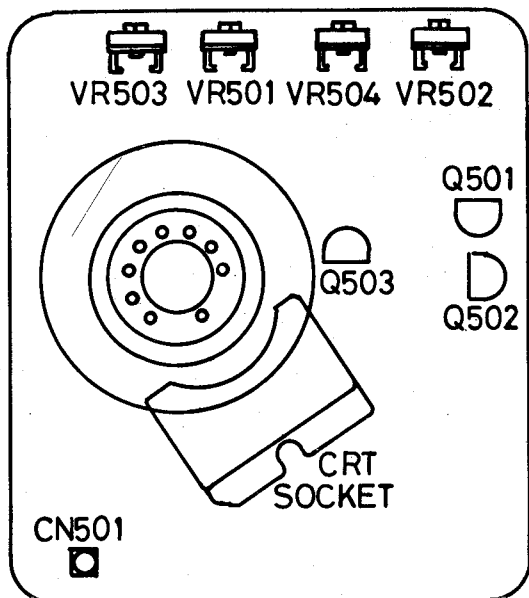

ALIGNMENT POINT OF POWER SUPPLY BOARD

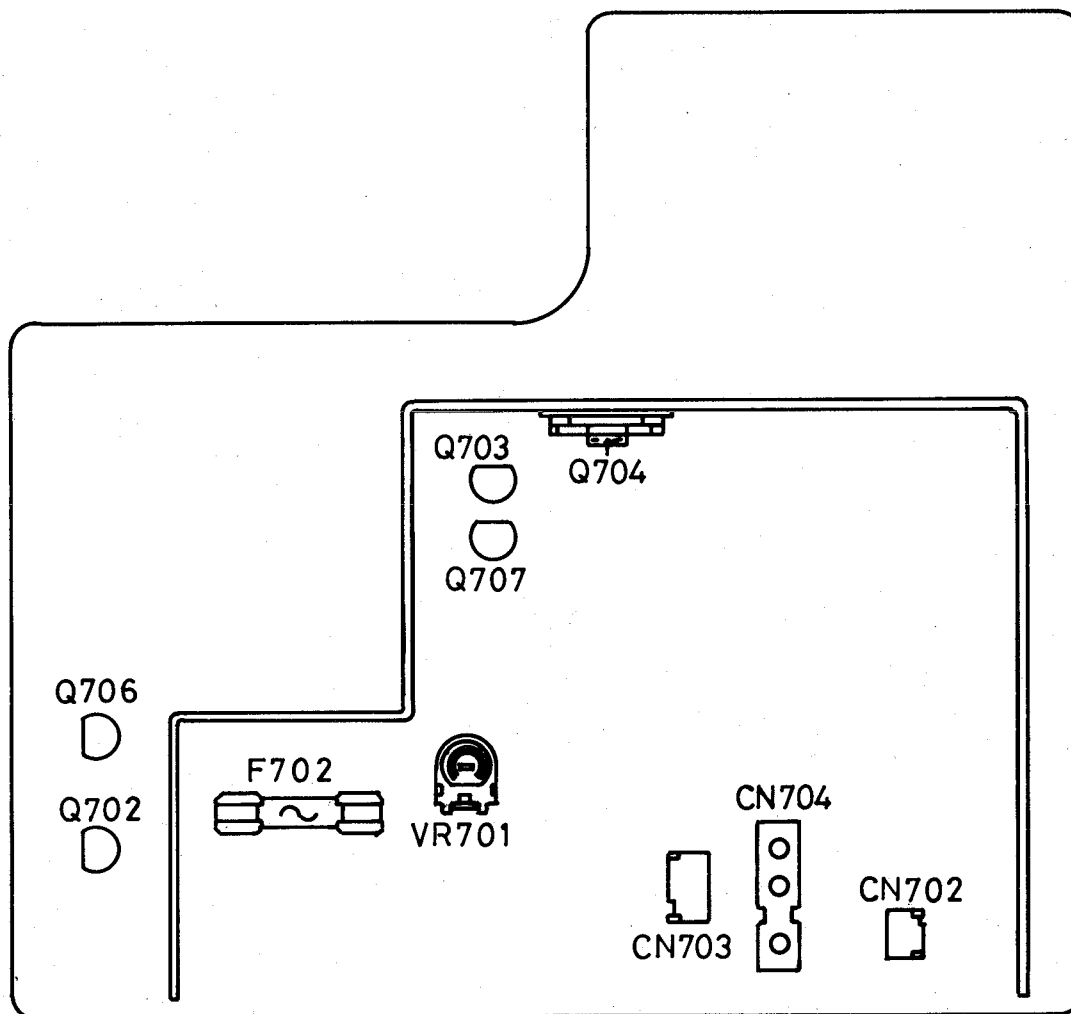

VOLTAGE TABLE FOR IC

SYMBOL. PIN NO.	IC 101 (V) AM	IC 101 (V) FM	IC 102 (V)	IC 201 (V)	IC 301 (V)	IC 302 (V)	IC 401 (V)	IC 601 (V)
1	9.57	9.4	0.6	5.0	5.17	1.39	GND	6.23
2	1.2	0.0	0.52	4.9	3.99	0.72	12	5.39
3	9.57	9.4	0.00	8.53	4.57	9.65	NC	9.29
4	1.14	0.00	GND	5.4	7.59	8.20	24	9.29
5	1.2	0.00	4.5	3.86	7.25	6.00	NC	5.93
6	9.0	9.0	9.37	7.7	7.11	1.67	0.76	5.44
7	9.5	9.47	9.26	3.2	0.33	2.88	0.00	9.23
8	0.86	0.00	6.0	3.2	2.31	2.87	0.85	5.87
9	1.8	2.37		5.0	2.31	2.84	24	9.23
10	9.5	9.47		5.0	9.64	GND		5.19
11	GND	GND		2.5	9.63	8.89		5.19
12	0.00	9.47		4.85	8.55	3.48		5.20
13	0.00	9.47		3.8	3.04	8.86		5.21
14	9.0	8.47		7.24	3.03	9.93		NC
15	9.0	8.3		7.2	0.00	3.48		9.65
16	9.0	8.55		9.64	11.0	5.74		8.17
17				2.32	GND	11.05		0.13
18				5.44		10.8		0.01
19				5.45				0.00
20				9.48				0.00
21				GND				0.00
22				3.5				0.00
23				1.00				0.01
24				5.25				0.02
25				0.1				7.24
26				2.00				NC
27				GND				9.89
28				5.00				NC

NOTE : Voltage are taken under tuned condition with

CONTRAST : Maximum Position
 BRIGHTNESS : Center Position
 COLOR : Center Position
 SIGNAL INPUT : 80 dB uV
 CHANNEL SETTING: The Last Channel of UHF High

VOLTAGE TABLE FOR TRANSISTOR

SYMBOL	B (V)	C (V)	E (V)
Q 101	1.9	9	1.2
Q 102	2.1	9.1	1.5
Q 201	0.5	9.5	0.3
Q 202	0.6	0.75	0.0
Q 203	0.7	GND	0.85
Q 204	0.7	0.2	0.0
Q 205	0.1	3.0	0.0
Q 301	3.5	6.9	2.94
Q 302	6.9	10.5	6.3
Q 303	0.30	11.2	0.20
Q 304	3.9	10.9	3.30
Q 401	6.4	8.14	0.07
Q 402	0.0	10	GND
Q 501	7.33	95	6.96
Q 502	7.26	99	6.81
Q 503	7.3	97	6.86
Q 601	9.2	9.8	9.8
Q 602	9.4	0.0	9.8
Q 702	0.0	14	0.0
Q 703	11.1	14	0.0
Q 704	10.5	14	9.9
Q 705	14	0.015	14
Q 706	9.9	14	9.3
Q 707	6.93	11.3	6.33

NOTE : Voltage are taken under tuned condition with
 CONTRAST : Maximum Position
 BRIGHTNESS : Center Position
 COLOR : Center Position
 SIGNAL INPUT : 80 dB uV
 CHANNEL SETTING: The Last Channel of UHF High

TRANSISTOR AND IC IDENTIFY

25A608G	25A719 25C930 25C1317 25C1685	25C1384 25C1573A 25D400	25D884	25D858	AN5512	TBA820M	TDA1220B	AN5612	AN5620X	LM8560	AN5150N

PICTORIAL VIEW OF TUNER

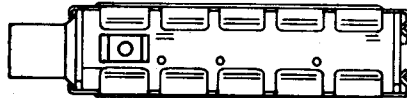

Terminal NO.	1	2	3	4	5	6	7	8	9
Terminal name	BU	VT	BH	AGC	BL	AFT	BM	IF	V/U ANT

IFT TUNING ADJUST

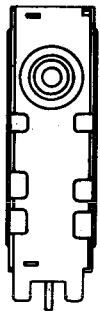

⑨

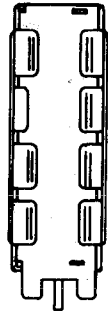
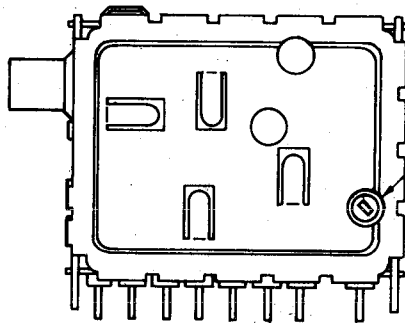

①②③④⑤⑥⑦⑧

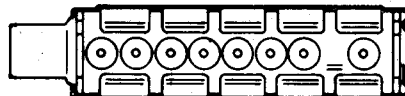

30-225

LVE.

SCHEMATIC DIAGRAM OF TUNER(FOR PAL-B/G SYSTEM)

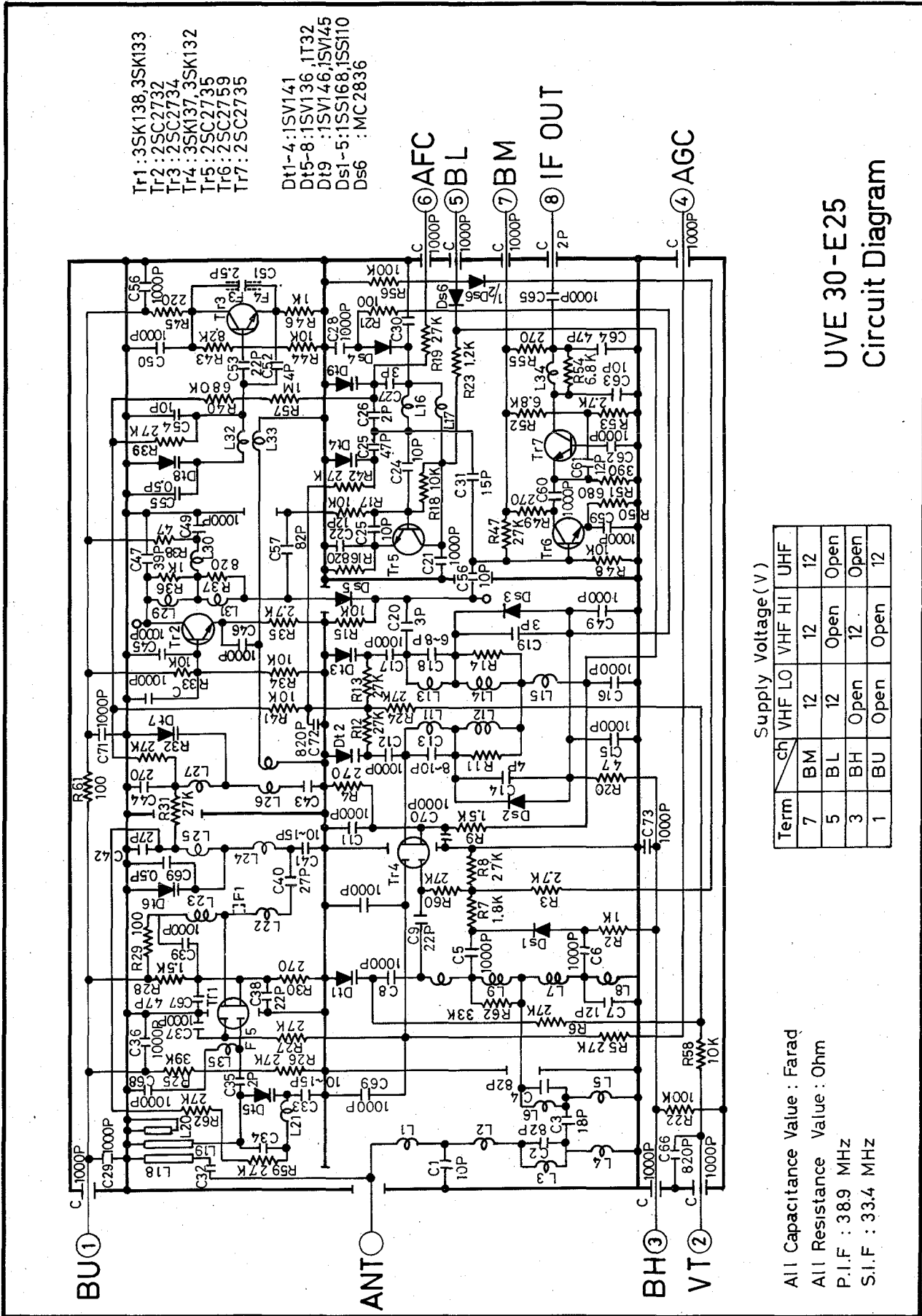

UVE 30-E25
Circuit Diagram

Term	Supply Voltage (V)			
	VHF LO	VHF HI	UHF	UHF
7	BM	12	12	12
5	BL	12	Open	Open
3	BH	Open	12	Open
1	BU	Open	Open	12

All Capacitance Value : Farad
 All Resistance Value : Ohm
 P.I.F : 389 MHz
 S.I.F : 33.4 MHz

TV DIAL CORD STRINGING DIAGRAM

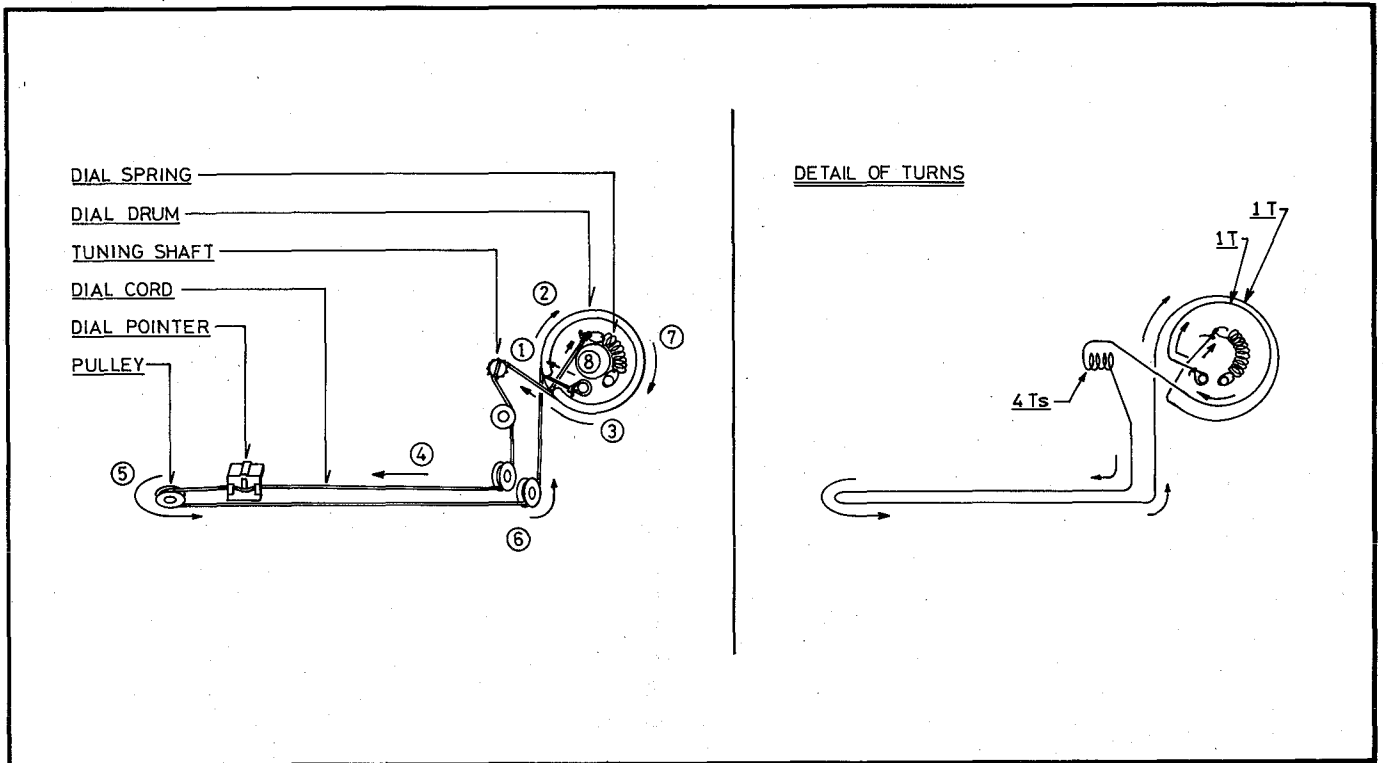

RADIO DIAL CORD STRINGING DIAGRAM

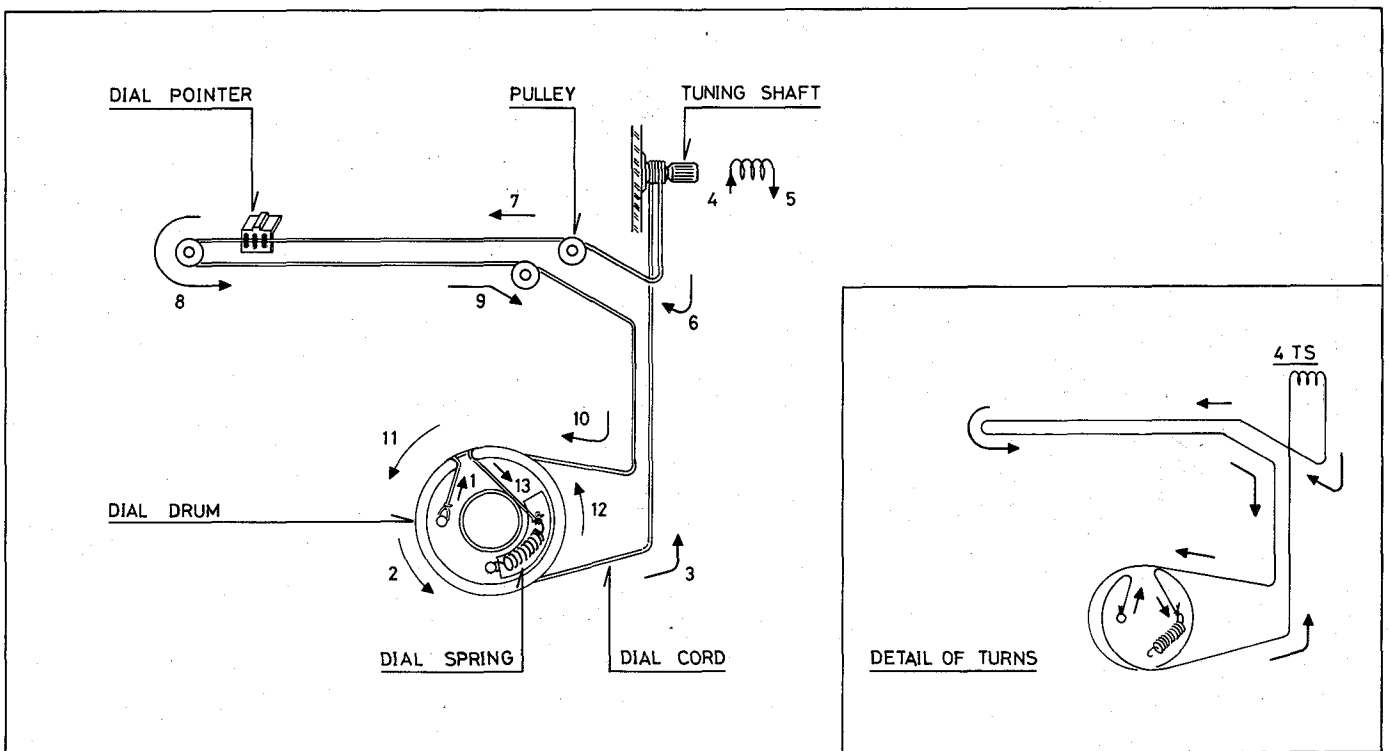

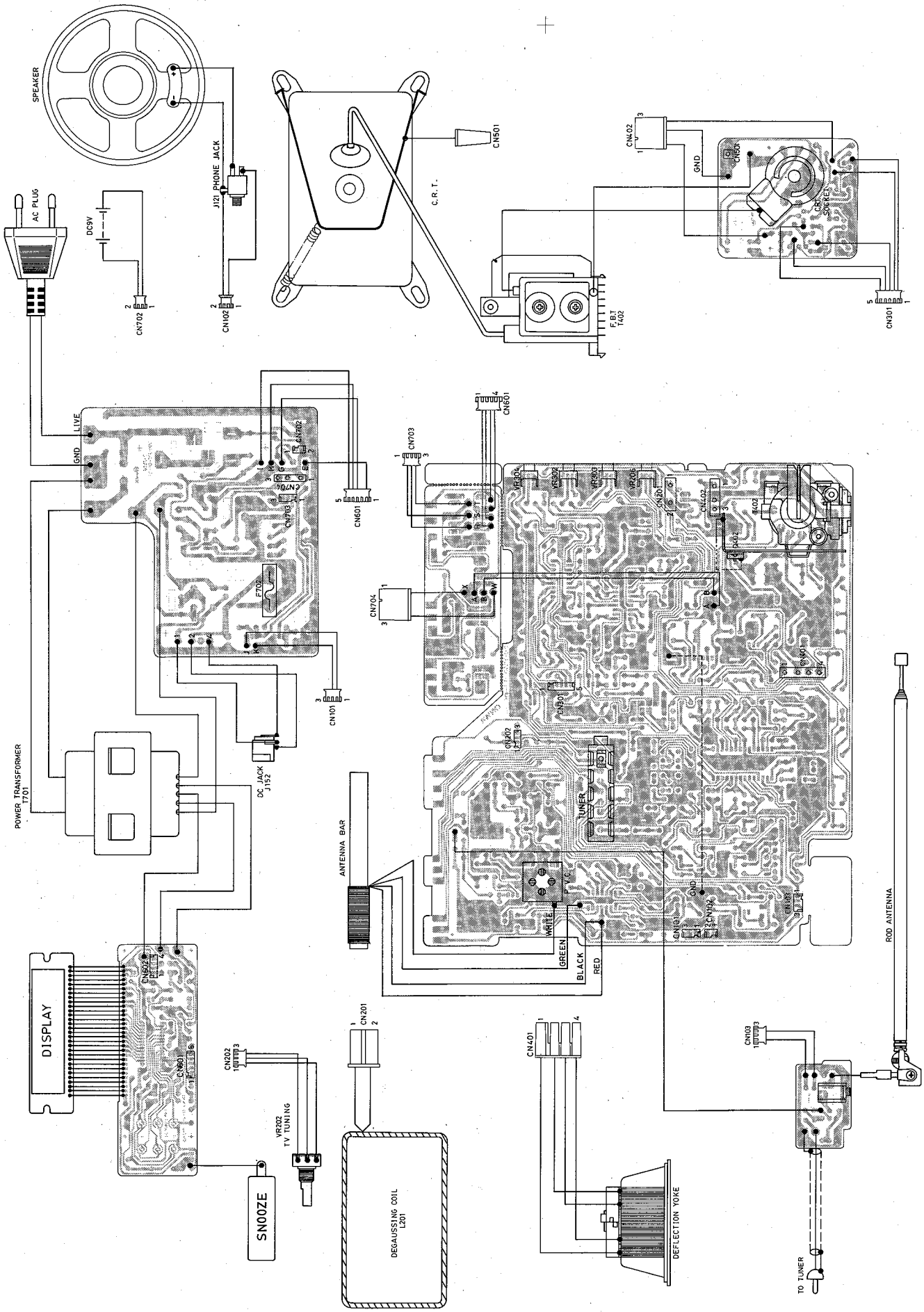

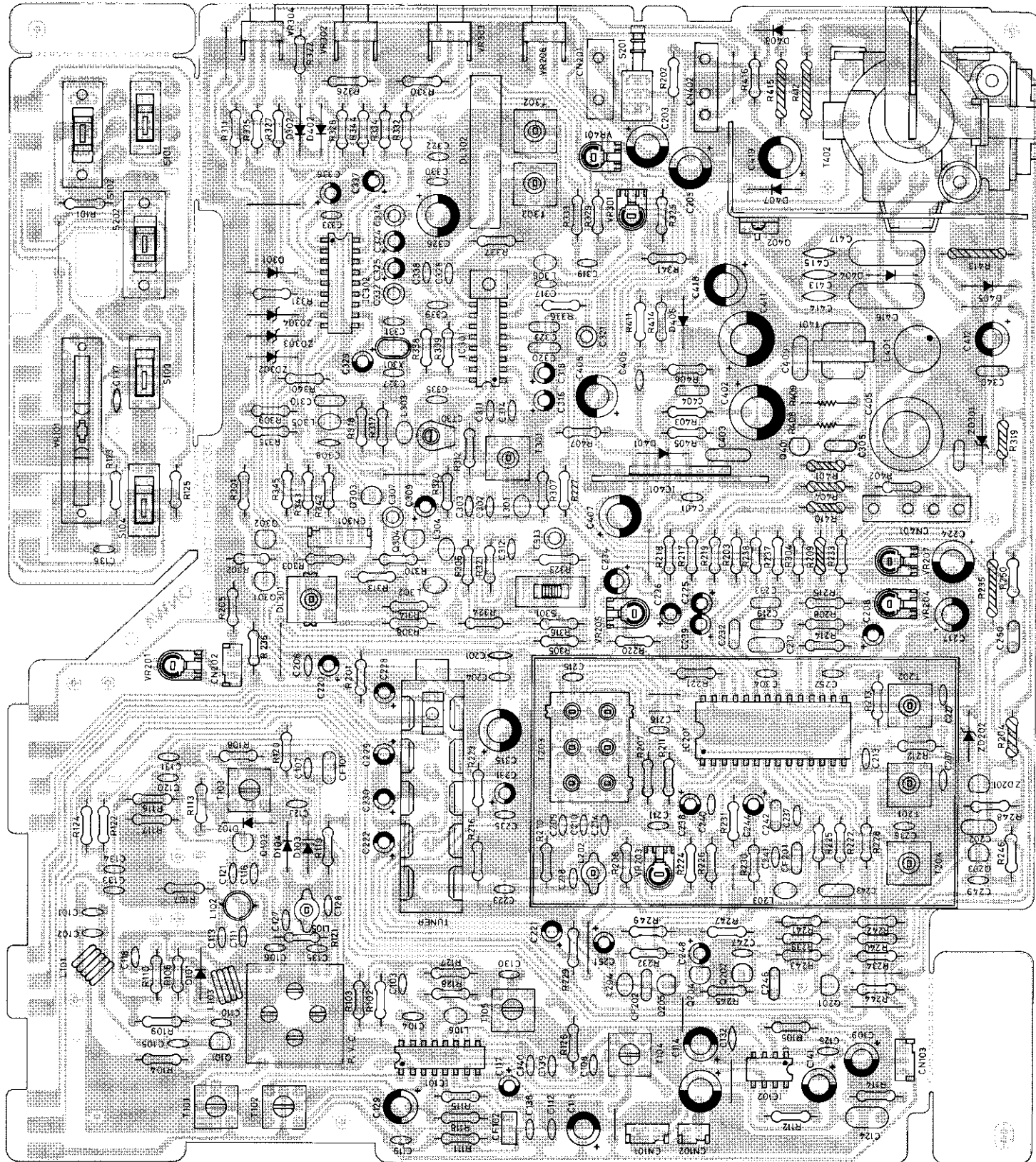

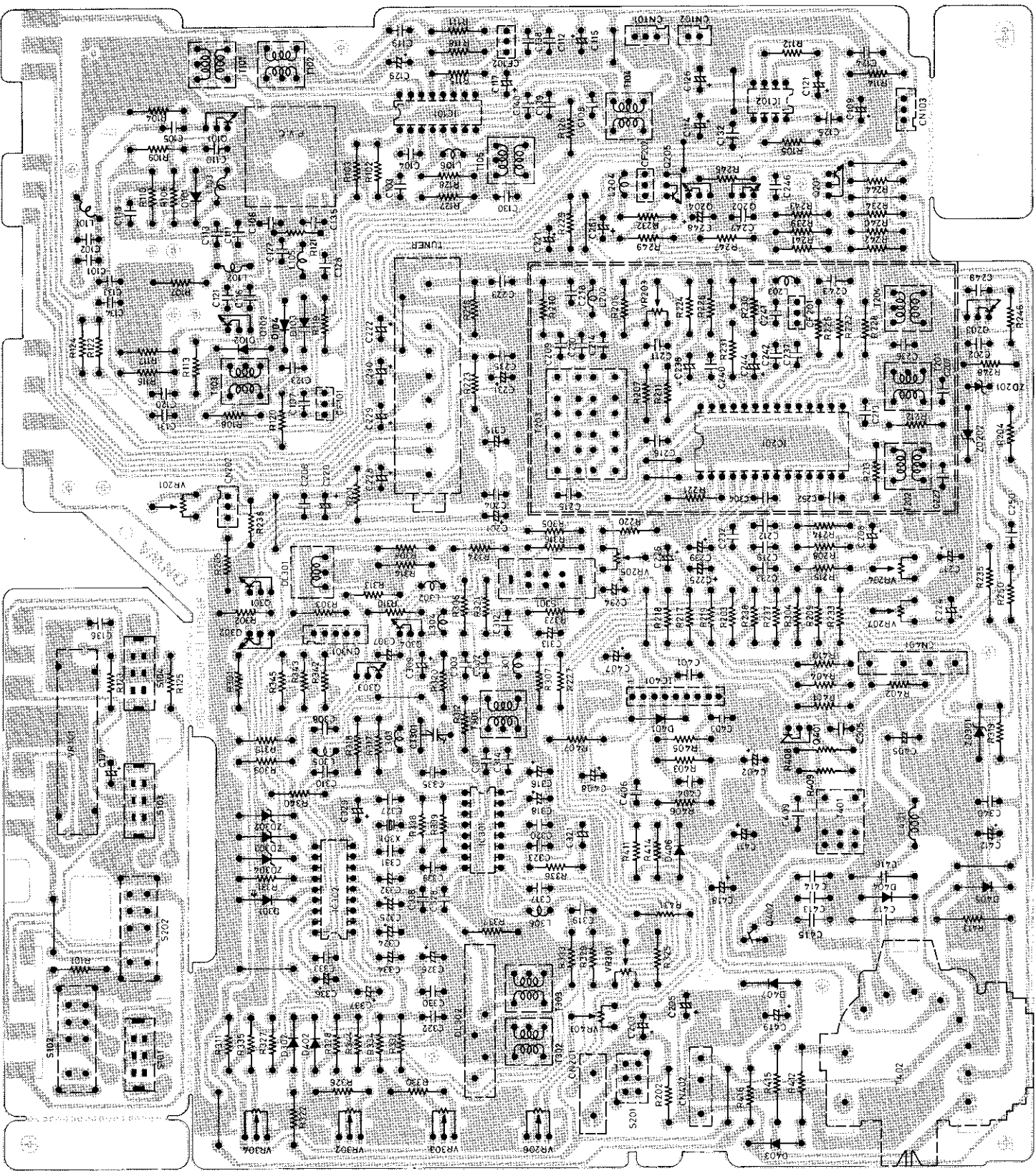

090-370501-1 110896 COMPONENT LAYOUT - BOTTOM VIEW

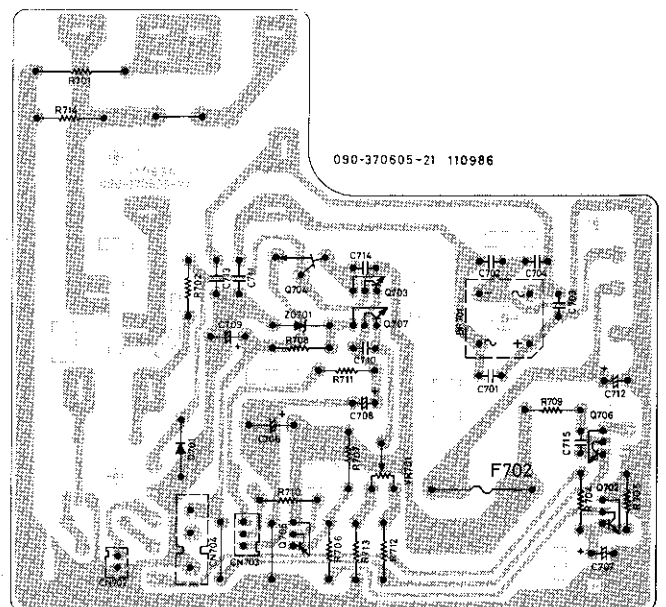
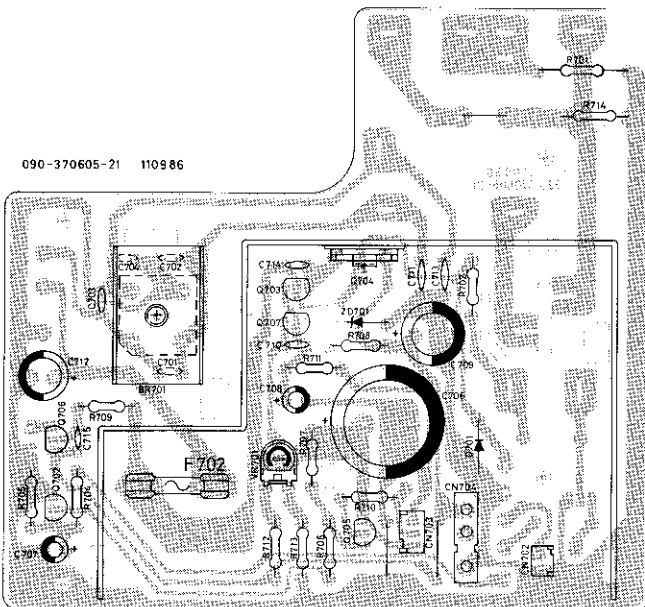
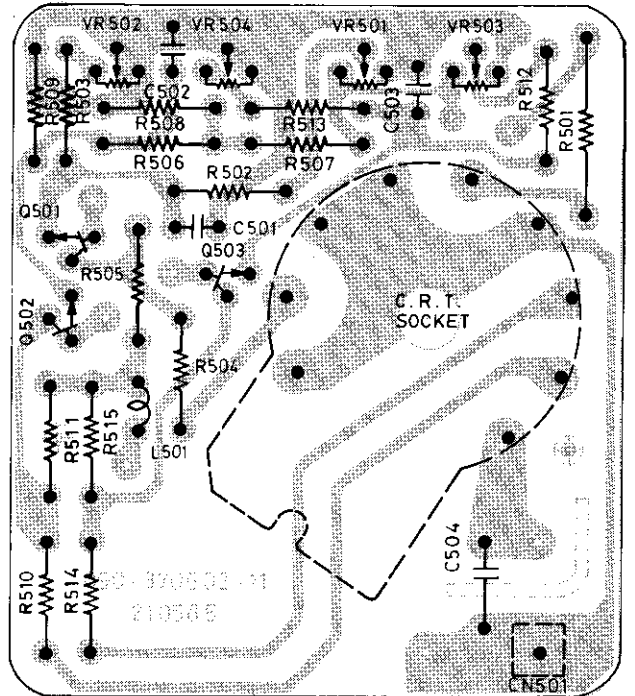
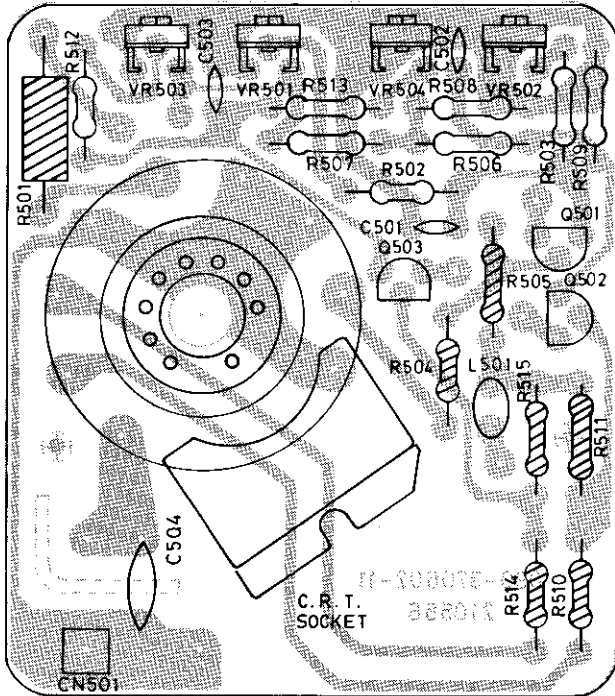

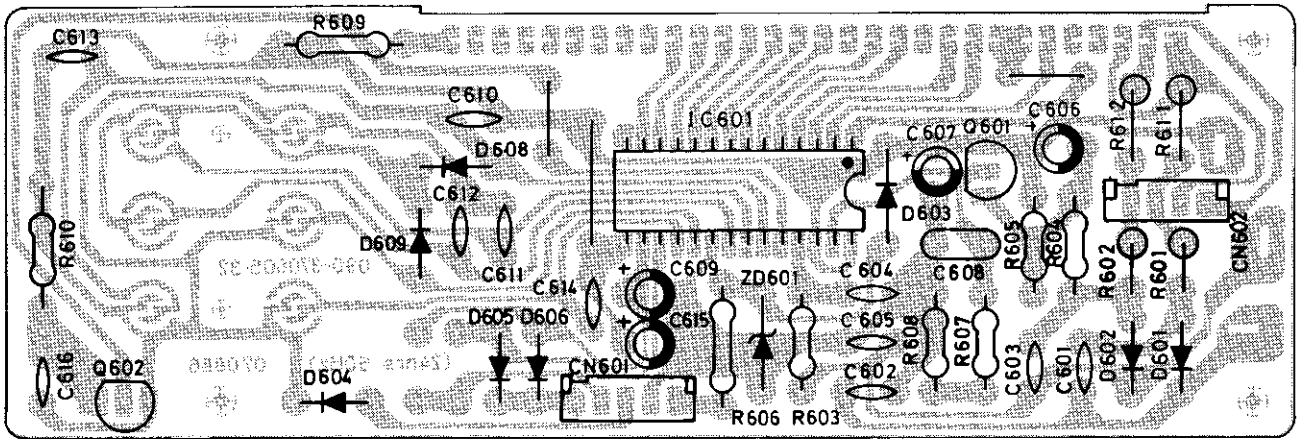

090-370605-32 070886

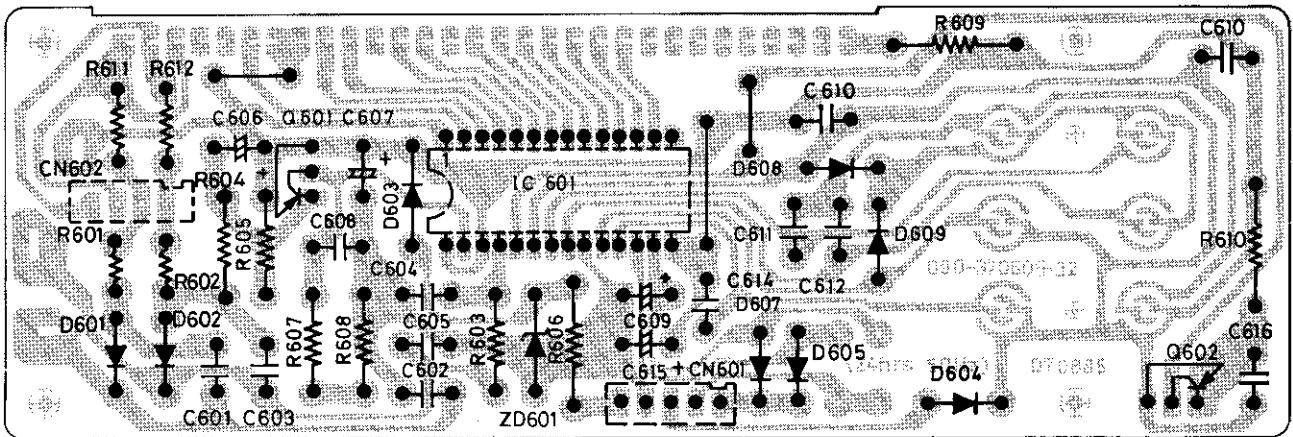

090-370605-32 070886

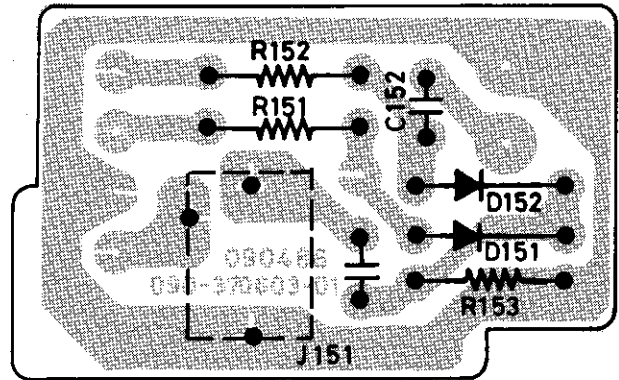
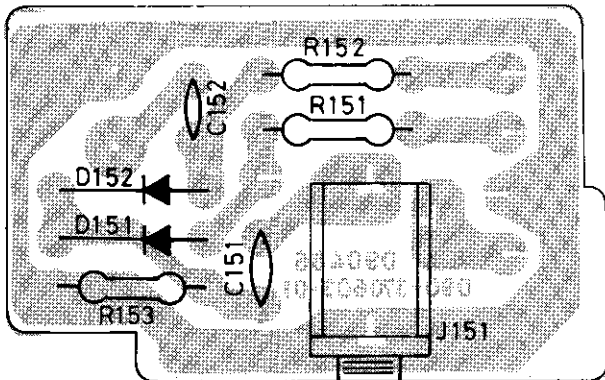

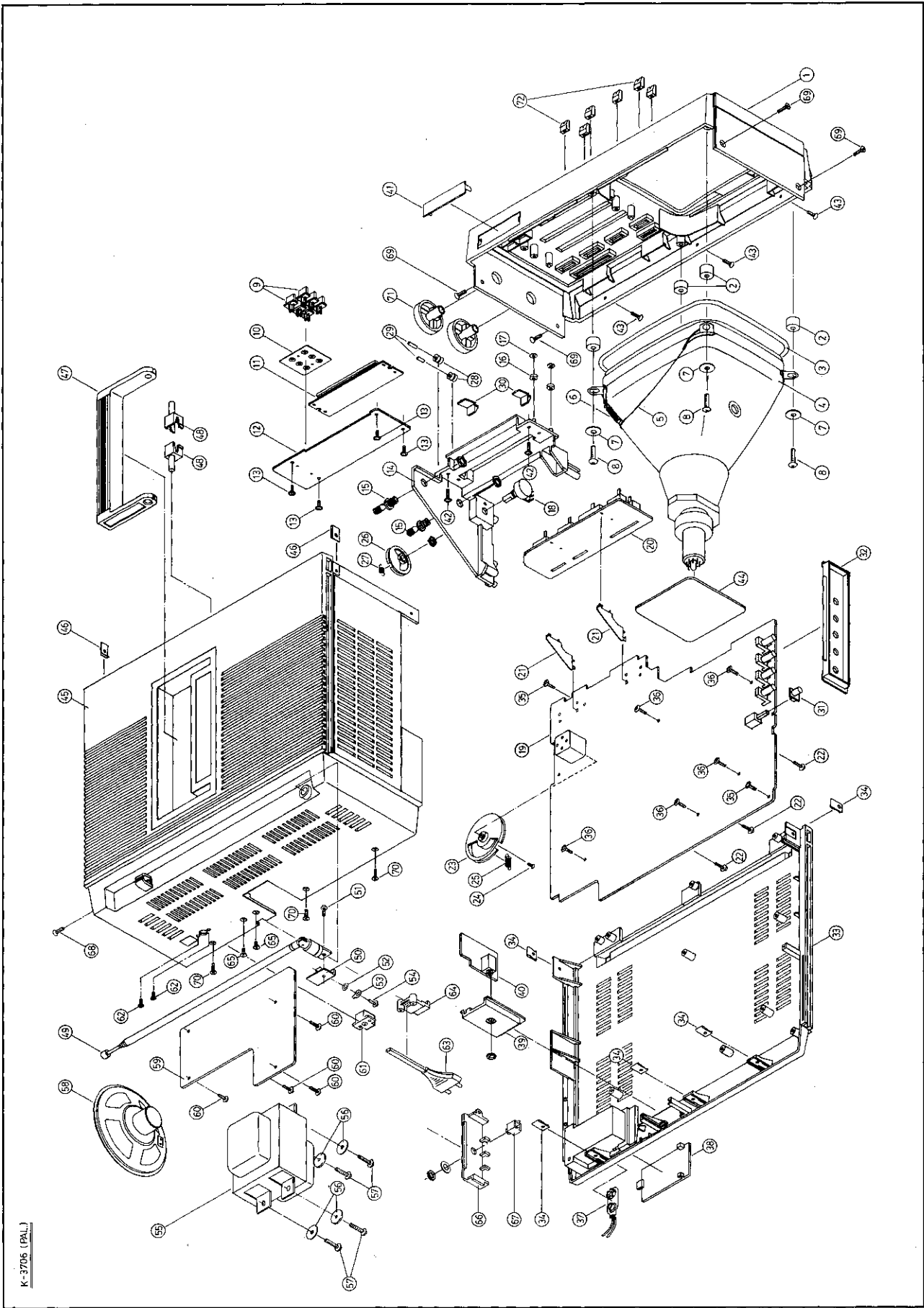

K-3705 (PAL)

EXPLODED VIEW PARTS LIST

<u>LOCATION</u>	<u>PARTS NO.</u>	<u>DESCRIPTION</u>	<u>QTY.</u>
1.	200-370601-01	CABINET FRONT	1
2.	334-370602-01	RUBBER SPACER	4
3.		DEGAUSSING COIL	1
4.		6" COLOR PICTURE TUBE	1
5.		FLAT BRAIDED WIRE	1
6.	477-371601-01	C.R.T. SPRING	1
7.	634-133042-15	PLAIN WASHER 13.3 x 4.2 x 1.5mm THK.	4
8.	614-400416-10	SELF-TAPPING SCREW B/T 4.0 x 16mm	4
9.	271-370601-01	CLOCK CONTROL KNOB	6
10.	334-370601-01	CONDUCTIVE RUBBER	1
11.		LED DISPLAY	1
12.		CLOCK P.C.BOARD ASS'Y	1
13.	612-260108-10	SELF-TAPPING SCREW W/T 2.6 x 8mm	4
14.	220-370601-01	CHASSIS BRACKET	1
15.	430-370601-01	TUNING SHAFT ASS'Y	2
16.	435-370501-01	DIAL PULLEY	2
17.	530-060029-04	FIBER WASHER	2
18.		ROTARY VOLUME W/NUT	1
19.		MAIN P.C.BOARD ASS'Y	1
20.		VOLUME P.C.BOARD ASS'Y	1
21.	428-370602-01	P.C.BOARD MTG. BRACKET	2
22.	612-300108-10	SELF-TAPPING SCREW W/T 3.0 x 8mm	3
23.	242-370501-01	DIAL DRUM (A)	1
24.	600-264506-10	MACHINE SCREW P/H 2.6 x 6mm	1
25.	477-701201-01	DIAL SPRING WIRE	1
26.	242-370502-01	DIAL DRUM (B)	1
27.	477-370502-01	DIAL SPRING WIRE	1
28.	435-370501-01	DIAL PULLEY	4
29.	431-370501-01	DIAL PULLEY SHAFT	2
30.	240-370601-01	DIAL POINTER	2
31.	291-370601-01	PUSH KNOB	1
32.	290-370604-01	SIDE SWITCH PLATE (B)	1
33.	203-370601-01	CABINET BOTTOM	1
34.	624-370501-01	SPRING NUT	5
35.	612-300108-10	SELF-TAPPING SCREW W/T 3.0 x 8mm	2
36.	612-300110-10	SELF-TAPPING SCREW W/T 3.0 x 10mm	5

EXPLODED VIEW PARTS LIST

<u>LOCATION</u>	<u>PARTS LIST</u>	<u>DESCRIPTION</u>	<u>QTY.</u>
37.	711-136000-00	BATTERY CLIP	1
38.	210-370501-01	BATTERY DOOR	1
39.	280-370603-01	ANT. JACK PLATE	1
40.		ANT. JACK P.C.BOARD ASS'Y	1
41.	449-370601-01	SENSOR PLATE	1
42.	612-300110-10	SELF-TAPPING SCREW W/T 3.0 x 10mm	2
43.	611-300310-10	SELF-TAPPING SCREW K/T 3.0 x 10mm	3
44.		C.R.T P.C.BOARD ASS'Y	1
45.	201-370601-01	CABINET TOP	1
46.	624-370501-01	SPRING NUT	2
47.	249-370601-01	HANDLE	1
48.	255-370601-01	HANDLE SUPPORTER	2
49.	482-707200-01	ROD ANTENNA	1
50.	428-370601-01	ANT. MTG. BRACKET	1
51.	600-305008-10	MACHINE SCREW P/H 3.0 x 8mm	1
52.	630-060032-10	EXTERNAL TOOTH WASHER M3	1
53.	450-371401-01	SOLDERING LUG	1
54.	612-300110-10	SELF-TAPPING SCREW W/T 3.0 x 10mm	1
55.		POWER TRANSFORMER EI-66	1
56.	634-133042-15	PLAIN WASHER 13.3 x 4.2 x 1.5mm THK.	4
57.	614-400416-10	SELF-TAPPING SCREW B/T 4.0 x 16mm	4
58.		SPEAKER 3.5"	1
59.		POWER P.C.BOARD ASS'Y	1
60.	612-300110-10	SELF-TAPPING SCREW W/T 3.0 x 10mm	4
61.		DC JACK	1
62.	601-264508-10	MACHINE SCREW K/H 2.6 x 8mm	2
63.		AC LINE CORD	1
64.	254-370601-01	AC LINE CORD STOPPER	1
65.	611-300310-10	SELF-TAPPING SCREW K/T 3.0 x 10mm	2
66.	290-370605-01	HEADPHONE JACK MTG. PLATE	1
67.		HEADPHONE JACK	1
68.	611-300310-10	SELF-TAPPING SCREW K/T 3.0 x 10mm	1
69.	611-300312-10	SELF-TAPPING SCREW K/T 3.0 x 12mm	4
70.	611-300310-10	SELF-TAPPING SCREW K/T 3.0 x 10mm	3
71.	270-370601-01	TUNING KNOB	2
72.	273-370601-01	SLIDE SWITCH KNOB	6

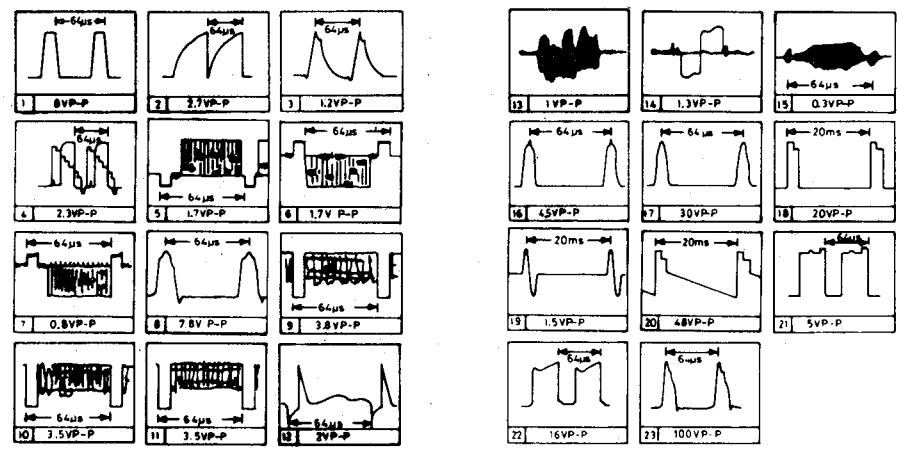
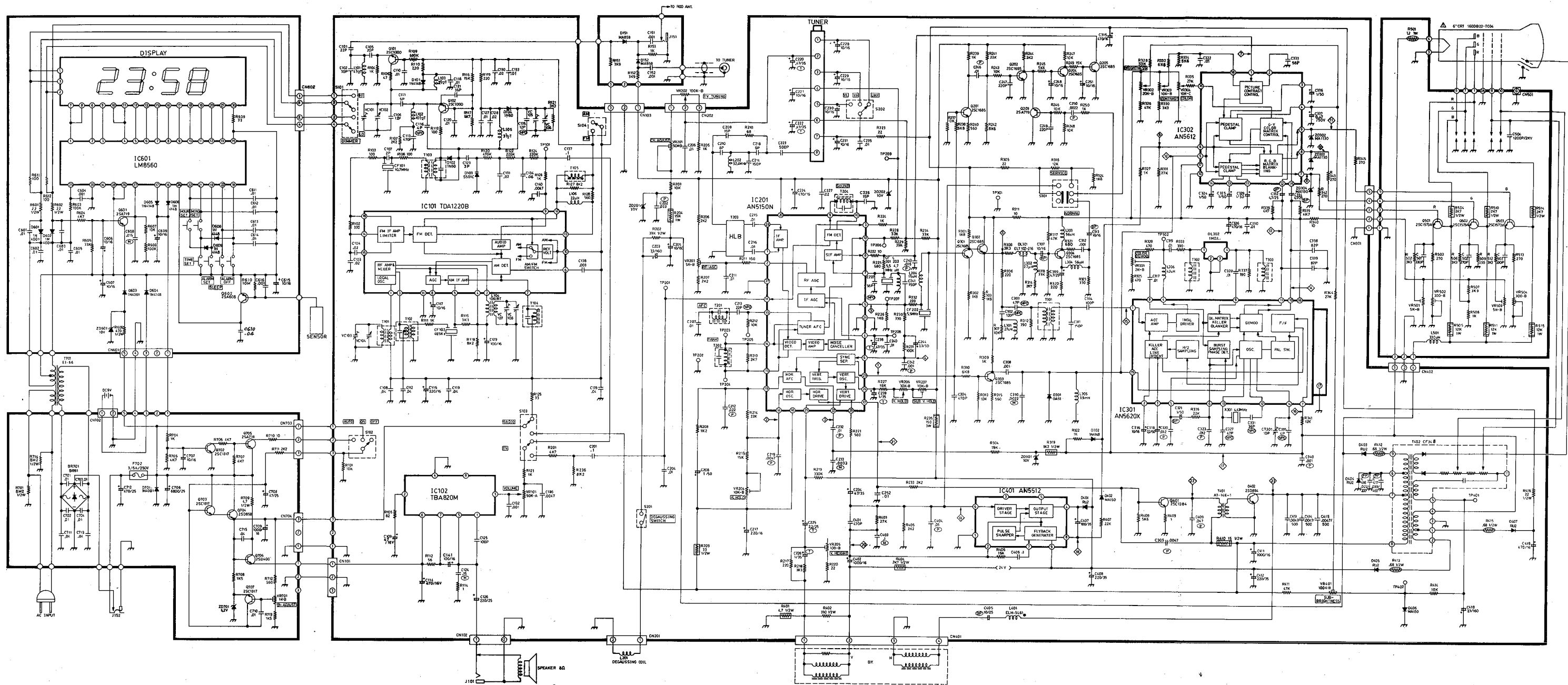

NOTE:

- ALL CAPACITORS ARE IN μF UNLESS OTHERWISE NOTED. ALL CAPACITORS ARE 50V UNLESS OTHERWISE NOTED.
- CAPACITOR NOT SPECIFICALLY DESIGNATED ARE CERAMIC CAPACITORS.
 - a ⏏ ELECTROLYTIC CAPACITOR
 - b ⏏ BI-POLAR ELECTROLYTIC CAPACITOR
 - c ⏏ TANTALUM CAPACITOR
 - d ⏏ METALLIZED POLYESTER
 - e ⏏ POLYESTER FILM CAPACITOR
 - f ⏏ POLYPROPYLENE CAPACITOR
 - g ⏏ MYLAR CAPACITOR
- ALL RESISTORS ARE IN OHM 1/4 WATT UNLESS OTHERWISE NOTED.
- RESISTOR NOT SPECIFICALLY DESIGNATED ARE CARBON FILM RESISTORS.
 - a ⏏ NONFLAMMABLE RESISTOR
 - b ⏏ FUSEBLE RESISTOR
 - c ⏏ CEMENT RESISTOR
 - d ⏏ METAL OXIDE RESISTOR
 - e ⏏ THERMISTOR

- DC VOLTAGE ARE MEASURED FROM POINTS INDICATED TO THE CIRCUIT GROUND WITH A MULTI-METER TEST.
- WAVEFORMS ARE TAKEN WITH SETTING CONTROLS TO A NORMAL CONDITIONS (COLOR BAR PATTERN)
- THIS CIRCUIT DIAGRAM IS SUBJECT TO CHANGE WITHOUT PRIOR NOTICE.

KONG WAH VIDEO ENGINEERING LTD.		
TITLE: SCHEMATIC DIAGRAM		
MODEL: K-3706	SYSTEM: PAL	
DRAWING NO: 3706-03	COUNTRY:	
DATE: 15-8-86	REV: NO 8 (15-10-86)	
DRAWN:	CHECKED:	APPROD: