

# SERVICE MANUAL

## ORION

COLOR TELEVISION RECEIVER

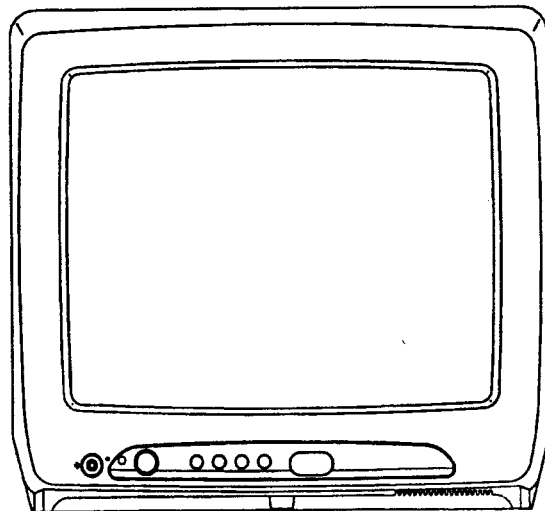

ORIGINAL  
CHASSIS CODE A

Best. Nr. SM3786

---

## SERVICING NOTICES ON CHECKING

### 1. KEEP THE NOTICES

As for the places which need special attentions, they are indicated with the labels or seals on the cabinet, chassis and parts. Make sure to keep the indications and notices in the operation manual.

### 2. AVOID AN ELECTRIC SHOCK

There is a high voltage part inside. Avoid an electric shock while the electric current is flowing.

### 3. USE THE DESIGNATED PARTS

The parts in this equipment have the specific characters of incombustibility and withstand voltage for safety. Therefore, the part which is replaced should be used the part which has the same character.

Especially as to the important parts for safety which is indicated in the circuit diagram or the table of parts as a  $\triangle$  mark, the designated parts must be used.

### 4. PUT PARTS AND WIRES IN THE ORIGINAL POSITION AFTER ASSEMBLING OR WIRING

There are parts which use the insulation material such as a tube or tape for safety, or which are assembled in the condition that these do not contact with the printed board. The inside wiring is designed not to get closer to the pyrogenic parts and high voltage parts. Therefore, put these parts in the original positions.

### 5. TAKE CARE TO DEAL WITH THE CATHODE-RAY TUBE

In the condition that an explosion-proof cathode-ray tube is set in this equipment, safety is secured against implosion. However, when removing it or serving from backward, it is dangerous to give a shock. Take enough care to deal with it.

### 6. AVOID AN X-RAY

Safety is secured against an X-ray by considering about the cathode-ray tube and the high voltage peripheral circuit, etc.

Therefore, when repairing the high voltage peripheral circuit, use the designated parts and make sure not modify the circuit.

Repairing except indicates causes rising of high voltage, and it emits an X-ray from the cathode-ray tube.

### 7. PERFORM A SAFETY CHECK AFTER SERVICING

Confirm that the screws, parts and wiring which were removed in order to service are put in the original positions, or whether there are the

serviced places serviced or not. Check the insulation between the antenna terminal or external metal and the AC cord plug blades. And be sure the safety of that.

#### (INSULATION CHECK PROCEDURE)

1. Unplug the plug from the AC outlet.
2. Remove the antenna terminal on TV and turn on the TV.
3. Insulation resistance between the cord plug terminals and the external exposure metal [Note 2] should be more than 1M ohm by using the 500V insulation resistance meter [Note 1].
4. If the insulation resistance is less than 1M ohm, the inspection repair should be required.

#### [Note 1]

If you have not the 500V insulation resistance meter, use a Tester.

#### [Note 2]

External exposure metal: Antenna terminal  
Earphone jack

## HOW TO ORDER PARTS

Please include the following informations when you order parts. (Particularly the CHASSIS CODE.)

1. MODEL NUMBER and CHASSIS CODE  
You can find it in the back of your unit.
2. PART NO. and DESCRIPTION  
You can find it in your SERVICE MANUAL.

## IMPORTANT

Inferior silicon grease can damage IC's and transistors.  
When replacing an IC's or transistors, use only specified silicon grease (YG6260M).  
Remove all old silicon before applying new silicon.

# CONTENTS

SERVICING NOTICES ON CHECKING .....	A1-1
HOW TO ORDER PARTS .....	A1-1
IMPORTANT .....	A1-1
CONTENTS .....	A2-1
GENERAL SPECIFICATIONS .....	A3-1~A3-4
DISASSEMBLY INSTRUCTIONS .....	B-1
SERVICE MODE LIST .....	C-1
CONFIRMATION OF HOURS USED .....	C-1
WHEN REPLACING EEPROM (MEMORY) IC .....	C-2
ELECTRICAL ADJUSTMENTS .....	D1-1~D2-1
MAJOR COMPONENTS LOCATION GUIDE .....	D3-1
BLOCK DIAGRAM .....	E-1, E-2
PRINTED CIRCUIT BOARDS	
MAIN/CRT .....	F-1~F-4
SCHEMATIC DIAGRAMS	
MICON/T.TEXT/TUNER .....	G-1, G-2
CHROMA/SIF/VIF .....	G-3, G-4
POWER .....	G-5, G-6
DEFLECTION/CRT .....	G-7, G-8
SOUND AMP .....	G-9, G-10
WAVEFORMS .....	H-1, H-2
MECHANICAL EXPLODED VIEW .....	I-1
MECHANICAL REPLACEMENT PARTS LIST .....	J1-1
ELECTRICAL REPLACEMENT PARTS LIST .....	J2-1, J2-2

## GENERAL SPECIFICATIONS

G-1	TV System	CRT	CRT Size / Visual Size	14 inch / 335.4mmV	
			CRT Type	Normal	
			Deflection	90 degree	
			Magnetic Field BV/BH	+0.45G/0.18G	
			Color System	PAL	
			Speaker	1 Speaker	
			Position	Bottom	
			Size	3 inch	
			Impedance	8 ohm	
			Sound Output	MAX 1.0 W 10%(Typical) 0.8 W	
	PAL60Hz	Yes			
G-2	Tuning System	Broadcasting System		CCIR System B/G	
		Tuner and Receive CH	System	1 Tuner	
			Destination	W/ Hyper	
			Tuning System	F-Synth	
			Input Impedance	VHF/UHF 75 ohm	
			CH Coverage	E2 - E4, X - Z+2, S1 - S10, E5 - E12, S11 - S41, E21 - E69	
		Intermediate Frequency	Picture(FP)	38.90MHz	
			Sound(FS)	33.4MHz	
			FP-FS	5.5MHz	
			Preset CH	80	
	Stereo/Dual TV Sound	No			
	Tuner Sound Muting	Yes			
G-3	Power	Power Source	AC	230V AC 50Hz	
			DC	-	
		Power Consumption		at AC	
			Stand by (at AC)	Per Year	44 W at AC 230 V 50 Hz 10 W at AC 230 V 50 Hz -- kWh/Year
		Protector	Power Fuse	Yes	
G-4	Regulation	Safety	CE		
		Radiation	CE		
		X-Radiation	PTB		
G-5	Temperature	Operation	+5°C ~ +40°C		
		Storage	-20°C ~ +60°C		
G-6	Operating Humidity		Less than 80% RH		
G-7	On Screen Display	Menu		Yes	
		Menu Type		Character	
		Picture		Yes	
			Contrast	Yes	
			Brightness	Yes	
			Color	Yes	
			Tint	No	
			Sharpness	Yes	
		Audio		No	
			Bass	No	
			Treble	No	
			Balance	No	
			BBE On/Off	No	
			Stable Sound On/Off	No	
		CH Tuning		Yes	
			Manual	Yes	
			Auto	Yes	
			CH Allocation	Yes	
		Language		Yes	
		Clock Set		No	
On/Off Timer Set		No			
Pin Code Registration		No			
Nicam Auto Off		No			
Colour System		No			
Sound System		No			

## GENERAL SPECIFICATIONS

		AV2 Output Source		No
		Control Level		Yes
		Volume		Yes
		Brightness		Yes
		Contrast		Yes
		Colour		Yes
		Tint (NTSC Only)		No
		Sharpness		Yes
		Tuning		Yes
		Bass		No
		Treble		No
		Balance		No
		Back Light		No
		Nicam ST		No
		Tone 1/2		No
		Pin Code		No
		AV		Yes
		Skip		Yes
		Channel		Yes
		Hotel Lock		No
		Sleep Timer		Yes
		Sound Mute		Yes
<b>G-8</b>	<b>OSD Language</b>		English French Spanish German Italian OSD Language Setting German	
<b>G-9</b>	<b>Clock and Timer</b>	Sleep Timer	Max Time	120 Min
			Step	10 Min
		On/Off Timer	Program(On Tim / Off Tim)	No
		Wake Up Timer		No
		Timer Back-up (at Power Off Mode)	more than	-- Min Sec
<b>G-10</b>	<b>Remote Control</b>	Unit		RC-DG
		Glow in Dark Remocon		No
		Format		NEC
		Custom Code		80-63 h
		Power Source	Voltage(D.C)	3V
			UM size x pcs	UM-4 x 2 pcs
		Total Keys		31 Keys
		Keys	Power(Stand By)	Yes
			1	Yes
			2	Yes
			3	Yes
			4	Yes
			5	Yes
			6	Yes
			7	Yes
			8	Yes
			9	Yes
			0 / AV	Yes
			CH Up	No
			CH Down	No
			Volume Up / +	Yes
			Volume Down / -	Yes
			Quick View	No
			Sleep	Yes
			Info(CH Call)	Yes
			Normal	No
			Menu	Yes
			Enter	Yes
			Mute	Yes
			Fine Tuning +	No
			Fine Tuning -	No
			Tone 1/2	No
		TTEXT Keys	TEXT / MIX / TV	Yes

## GENERAL SPECIFICATIONS

		CH Up / Page Up	Yes	
		CH Down / Page Down	Yes	
		Red	Yes	
		Green	Yes	
		Yellow / Fine Tuning -	Yes	
		Cyan / Fine Tuning +	Yes	
		F/T/B(Expand) / Normal	Yes	
		Reveal / Skip	Yes	
		Display Cancel	Yes	
		Reset	Yes	
		Reset / Tone 1/2	No	
		Hold / Status	Yes	
		Sub Page / Quick View	Yes	
G-11	Features	Auto Degauss	Yes	
		Auto Shut Off	Yes	
		Canal+	No	
		CATV	Yes	
		Anti-theft	No	
		Memory(Last CH)	Yes	
		Memory(Last Volume)	Yes	
		BBE	No	
		Auto Search	Yes	
		CH Allocation	Yes	
		Channel Lock	No	
		Just Clock Function	No	
		Game Position	No	
		CH Label	No	
		VM Circuit	No	
		Full OSD	No	
		Unitext	Yes	
		Fastext	No	
		Top Text	No	
		Premiere	No	
		Comb Filter	No	
			Lines	
			Auto CH Memory	Yes
	Auto Set Up	No		
	Stable Sound	No		
	FBT Leak Test Protect	No		
	Hotel Lock	No		
G-12	Accessories	Owner's Manual	Language	German
			w/Guarantee Card	Yes
		Remote Control Unit		Yes
		Rod Antenna		No
			Poles	-
			Terminal	-
		Loop Antenna		No
			Terminal	-
		U/V Mixer		No
		DC Car Cord (Center+)		No
		Guarantee Card		No
		Warning Sheet		No
		Circuit Diagram		No
		Antenna Change Plug		No
		Service Facility List		No
		Important Safeguard		No
		Dew/AHC Caution Sheet		No
		AC Plug Adapter		No
		Quick Set-up Sheet		No
		Battery		Yes
	UM size x pcs	UM-4 x 2 pcs		
	OEM Brand	No		
	AC Cord	No		

## GENERAL SPECIFICATIONS

		AV Cord (2Pin-1Pin)		No		
		Registration Card		No		
		PTB Sheet		No		
		300 ohm to 75 ohm Antenna Adapter		No		
G-13	Interface	Switch	Front	Power	No	
				System Select	No	
				Main Power SW	Yes	
				Sub Power	No	
				Channel Up	Yes	
				Channel Down	Yes	
				Volume Up	Yes	
				Volume Down	Yes	
			Rear	AC/DC	No	
				TV/CATV Selector	No	
				Degauss	No	
				Main Power SW	No	
			Indicator	Power	No	
				Stand-by	Yes	
				On Timer	No	
			Terminals	Front	Video Input	No
					Audio Input	No
					Other Terminal	Ear Phone
				Rear	Video Input(Rear1)	No
					Video Input(Rear2)	No
					Audio Input(Rear1)	No
					Audio Input(Rear2)	No
					Video Output	No
					Audio Output	No
					Euro Scart(21Pin)	Yes ( x1 )
					Component Input	No
					Diversity	No
					Ext Speaker	No
					DC Jack 12V(Center +)	No
					VHF/UHF Antenna Input	Din Type
					AC Outlet	No
		G-14	Set Size	Approx. W x D x H (mm)		362 x 360 x 320.5
G-15	Weight	Net (Approx.)		9.5 kg (--- lbs)		
		Gross (Approx.)		11.5kg (---lbs)		
G-16	Carton	Master Carton		No		
		Content		---- Sets		
		Material		-- /--		
		Dimensions W x D x H(mm)		-- x -- x --		
		Description of Origin		No		
		Gift Box		Yes		
		Material		Double/White		
		Dimensions W x D x H(mm)		440 x 408 x 380		
		Design		As per Buyer's		
		Description of Origin		No		
		Drop Test		Natural Dropping At 1 Corner / 3 Edges / 6 Surfaces		
Height (cm)		62				
Container Stuffing		866 Sets/40' container				
G-17	Cabinet Material	Cabinet Front		PS 94HB		
		Cabinet Rear		PS 94HB		

## DISASSEMBLY INSTRUCTIONS

### 1. REMOVAL OF ANODE CAP

Read the following **NOTED** items before starting work.

- ★ After turning the power off there might still be a potential voltage that is very dangerous. When removing the Anode Cap, make sure to discharge the Anode Cap's potential voltage.
- ★ Do not use pliers to loosen or tighten the Anode Cap terminal, this may cause the spring to be damaged.

#### REMOVAL

1. Follow the steps as follows to discharge the Anode Cap. (Refer to Fig. 3-1.)

Connect one end of an Alligator Clip to the metal part of a flat-blade screwdriver and the other end to ground. While holding the plastic part of the insulated Screwdriver, touch the support of the Anode with the tip of the Screwdriver.

A cracking noise will be heard as the voltage is discharged.

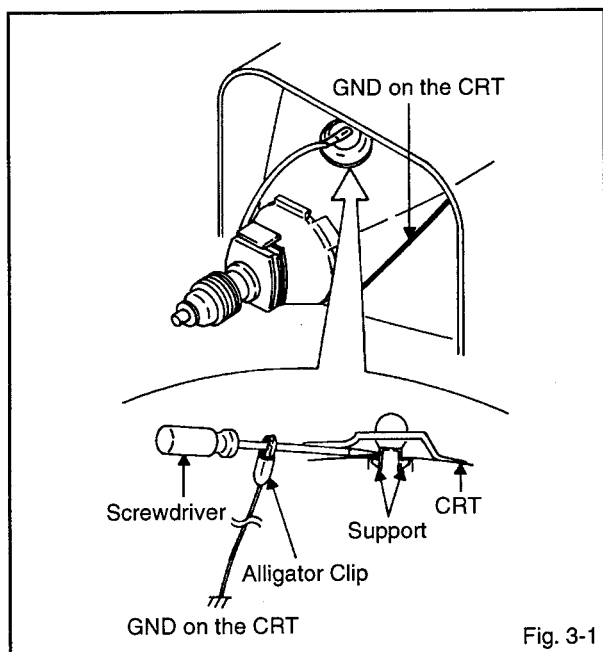

Fig. 3-1

2. Flip up the sides of the Rubber Cap in the direction of the arrow and remove one side of the support. (Refer to Fig. 3-2.)

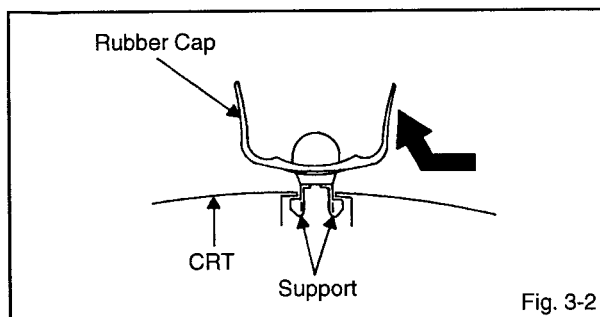

Fig. 3-2

3. After one side is removed, pull in the opposite direction to remove the other.

#### NOTE

Take care not to damage the Rubber Cap.

#### INSTALLATION

1. Clean the spot where the cap was located with a small amount of alcohol. (Refer to Fig. 3-3.)

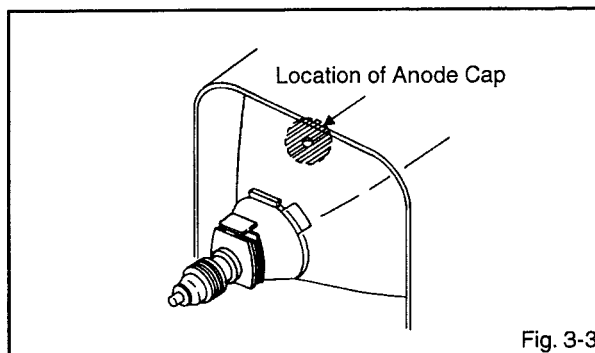

Fig. 3-3

#### NOTE

Confirm that there is no dirt, dust, etc. at the spot where the cap was located.

2. Arrange the wire of the Anode Cap and make sure the wire is not twisted.
3. Turn over the Rubber Cap. (Refer to Fig. 3-4.)

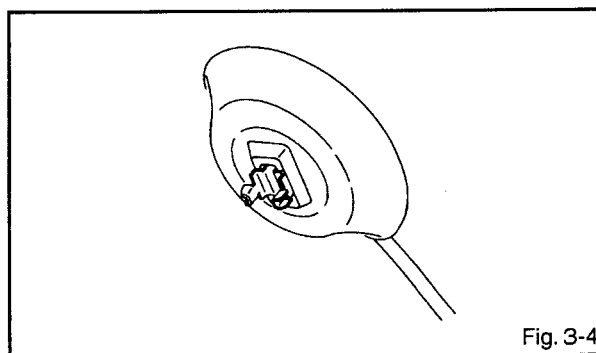

Fig. 3-4

4. Insert one end of the Anode Support into the anode button, then the other as shown in Fig. 3-5.

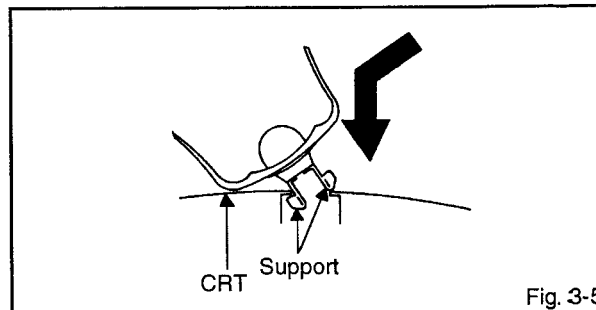

Fig. 3-5

5. Confirm that the Support is securely connected.
6. Put on the Rubber Cap without moving any parts.



## WHEN REPLACING EEPROM (MEMORY) IC

If a service repair is undertaken where it has been required to change the MEMORY IC, the following steps should be taken to ensure correct data settings while making reference to TABLE 1.

INI	+0	+1	+2	+3	+4	+5	+6	+7	+8	+9	+A	+B	+C	+D	+E	+F
00	--	00	00	00	00	59	94	41	01	41	14	8D	0B	07	0C	FF
10	00	00	08	2D	03	00	00	7E	46	10	34	08	00	44	A3	21
20	C7	2A	9F	20	D6	2E	95	08	0A	06	00	20	00	E2	18	18
30	00	50	50	50	00	00	00	03	2D	2D	2D	2D	2D	2D	2D	2D
40	7F	75	6B	66	63	60	5D	5A	57	54	51	4E	4B	48	45	42
50	3F	3D	3B	39	37	35	33	31	2F	2D	2B	29	27	25	23	21
60	1F	1E	1D	1C	1B	1A	19	18	17	16	15	14	13	12	11	10
70	0F	0E	0D	0C	0B	0A	09	08	07	06	05	04	03	03	02	02

**Table 1**

1. Enter DATA SET mode by setting VOLUME to minimum.
2. Press both VOL. DOWN button on the set and Channel button (6) on the remote control.  
ADDRESS and DATA should appear as FIG. 1.
3. ADDRESS is now selected and should "blink". Using the SET + or - keys on the remote, step through the ADDRESS until required ADDRESS to be changed is reached.
4. Press ENTER to select DATA. When DATA is selected, it will "blink".
5. Again, step through the DATA using SET + or - until required DATA value has been selected.
6. Press ENTER will take you back to ADDRESS for further selected if necessary.
7. Repeat steps 3 to 6 until all data has been checked.
8. When satisfied correct DATA has been entered, turn POWER off (return to STANDBY MODE) to finish DATA input.  
The unit will now have the correct DATA for the new MEMORY IC.

## SERVICE MODE LIST

This unit provided with the following SERVICE MODES so you can repair, examine and adjust easily.  
To enter the Service Mode, press both set key and remote control key for more than 2 seconds.

Set Key	Remocon Key	Operations
VOL. (-) MIN	0	Reset the user setting items (PICTURE, VOLUME, LANGUAGE and NICAM AUTO/OFF) to the initial state for delivery.
VOL. (-) MIN	1	Initialization of the factory. NOTE: Do not use this for the normal servicing. If you set a factory initialization, the memories are reset such as the clock setting, the channel setting, the POWER ON total hours, and PLAY/REC total hours.
VOL. (-) MIN	6	POWER ON total hours is displayed on the screen. Refer to the "CONFIRMATION OF HOURS USED".  Can be checked of the INITIAL DATA of MEMORY IC. Refer to the "WHEN REPLACING EEPROM (MEMORY) IC".
VOL. (-) MIN	8	Writing of EEPROM initial data. NOTE: Do not use this for the normal servicing.
VOL. (-) MIN	9	Display of the Adjustment MENU on the screen. Refer to the "ELECTRICAL ADJUSTMENT" (On-Screen Display Adjustment).

### CONFIRMATION OF HOURS USED

POWER ON total hours can be checked on the screen. Total hours are displayed in 16 system of notation.

1. Set the VOLUME to minimum.
2. Press both VOL. DOWN button on the set and Channel button (6) on the remote control.
3. After the confirmation of using hours, turn off the power.

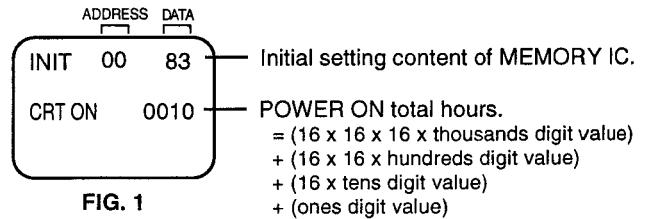

## ELECTRICAL ADJUSTMENTS

### 1. BEFORE MAKING ELECTRICAL ADJUSTMENTS

Read and perform these adjustments when repairing the circuit or replacing parts or PCB assemblies.

#### CAUTION

- \* Use an isolation transformer when performing any service on this chassis.
- \* Before removing the anode cap, discharge electricity because it contains high voltage.
- \* When removing a PCB or related component, after unfastening or changing a wire, be sure to put the wire back in this original position.  
Inferior silicon grease can damage IC's and transistors.
- \* When you exchange IC and Transistor for a heat sink, apply the silicon grease (YG6260M) on the contract section of the heat sink, Before applying new silicon grease, remove all the old silicon grease. (Old grease may cause damages to the IC and Transistor.)

Prepare the following measurement tools for electrical adjustments.

1. Oscilloscope
2. Digital Voltmeter
3. Pattern Generator

#### On-Screen Display Adjustment

1. In the condition of NO indication on the screen. Press the VOL. DOWN button on the set and the Channel button (9) on the remote control for more than 2 seconds to appear the adjustment mode on the screen as show in FIG. 1-1.

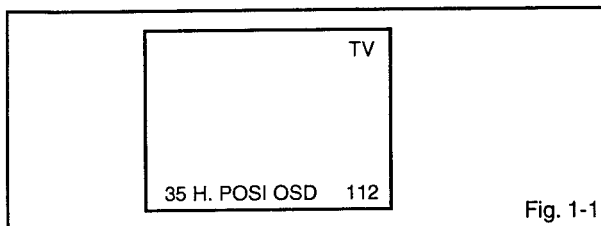

Fig. 1-1

2. Use the Channel UP/DOWN button or Channel button (0-9) on the remote control to select the options show in Fig. 1-2.
3. Press the MENU button on the remote control to end the adjustments.

<table style="width: 100%; border-collapse: collapse;"> <tr> <th style="text-align: left;">NO.</th> <th style="text-align: left;">FUNCTION</th> </tr> <tr><td>00</td><td>CUT OFF</td></tr> <tr><td>01</td><td>RF AGC</td></tr> <tr><td>02</td><td>AGC GAIN</td></tr> <tr><td>03</td><td>R DRIVE</td></tr> <tr><td>04</td><td>R CUT OFF</td></tr> <tr><td>05</td><td>G DRIVE</td></tr> <tr><td>06</td><td>G CUT OFF</td></tr> <tr><td>07</td><td>B DRIVE</td></tr> <tr><td>08</td><td>H POSI 50</td></tr> <tr><td>09</td><td>V POSI 50</td></tr> <tr><td>10</td><td>V POSI 60</td></tr> <tr><td>11</td><td>V SIZE 50</td></tr> <tr><td>12</td><td>V SIZE 60</td></tr> <tr><td>13</td><td>VCO COARSE</td></tr> <tr><td>14</td><td>VCO FINE</td></tr> <tr><td>15</td><td>-</td></tr> <tr><td>16</td><td>-</td></tr> <tr><td>17</td><td>BRIGHT CENT</td></tr> <tr><td>18</td><td>BRIGHT MAX</td></tr> <tr><td>19</td><td>BRIGHT MIN</td></tr> </table>	NO.	FUNCTION	00	CUT OFF	01	RF AGC	02	AGC GAIN	03	R DRIVE	04	R CUT OFF	05	G DRIVE	06	G CUT OFF	07	B DRIVE	08	H POSI 50	09	V POSI 50	10	V POSI 60	11	V SIZE 50	12	V SIZE 60	13	VCO COARSE	14	VCO FINE	15	-	16	-	17	BRIGHT CENT	18	BRIGHT MAX	19	BRIGHT MIN	<table style="width: 100%; border-collapse: collapse;"> <tr> <th style="text-align: left;">NO.</th> <th style="text-align: left;">FUNCTION</th> </tr> <tr><td>20</td><td>TINT</td></tr> <tr><td>21</td><td>SHARP</td></tr> <tr><td>22</td><td>CONT CENT</td></tr> <tr><td>23</td><td>CONT MAX</td></tr> <tr><td>24</td><td>CONT MIN</td></tr> <tr><td>25</td><td>COLOR CENT</td></tr> <tr><td>26</td><td>COLOR MAX</td></tr> <tr><td>27</td><td>COLOR MIN</td></tr> <tr><td>28</td><td>M R CUT OFF</td></tr> <tr><td>29</td><td>M G CUT OFF</td></tr> <tr><td>30</td><td>M B CUT OFF</td></tr> <tr><td>31</td><td>CVBS OUT</td></tr> <tr><td>32</td><td>APR THR</td></tr> <tr><td>33</td><td>BELL</td></tr> <tr><td>34</td><td>BANDPASS</td></tr> <tr><td>35</td><td>H POSI OSD</td></tr> <tr><td>36</td><td>V POSI OSD</td></tr> <tr><td>37</td><td>H POSI TXT</td></tr> <tr><td>38</td><td>V POSI TXT</td></tr> <tr><td>39</td><td>H POSI 60</td></tr> </table>	NO.	FUNCTION	20	TINT	21	SHARP	22	CONT CENT	23	CONT MAX	24	CONT MIN	25	COLOR CENT	26	COLOR MAX	27	COLOR MIN	28	M R CUT OFF	29	M G CUT OFF	30	M B CUT OFF	31	CVBS OUT	32	APR THR	33	BELL	34	BANDPASS	35	H POSI OSD	36	V POSI OSD	37	H POSI TXT	38	V POSI TXT	39	H POSI 60
NO.	FUNCTION																																																																																				
00	CUT OFF																																																																																				
01	RF AGC																																																																																				
02	AGC GAIN																																																																																				
03	R DRIVE																																																																																				
04	R CUT OFF																																																																																				
05	G DRIVE																																																																																				
06	G CUT OFF																																																																																				
07	B DRIVE																																																																																				
08	H POSI 50																																																																																				
09	V POSI 50																																																																																				
10	V POSI 60																																																																																				
11	V SIZE 50																																																																																				
12	V SIZE 60																																																																																				
13	VCO COARSE																																																																																				
14	VCO FINE																																																																																				
15	-																																																																																				
16	-																																																																																				
17	BRIGHT CENT																																																																																				
18	BRIGHT MAX																																																																																				
19	BRIGHT MIN																																																																																				
NO.	FUNCTION																																																																																				
20	TINT																																																																																				
21	SHARP																																																																																				
22	CONT CENT																																																																																				
23	CONT MAX																																																																																				
24	CONT MIN																																																																																				
25	COLOR CENT																																																																																				
26	COLOR MAX																																																																																				
27	COLOR MIN																																																																																				
28	M R CUT OFF																																																																																				
29	M G CUT OFF																																																																																				
30	M B CUT OFF																																																																																				
31	CVBS OUT																																																																																				
32	APR THR																																																																																				
33	BELL																																																																																				
34	BANDPASS																																																																																				
35	H POSI OSD																																																																																				
36	V POSI OSD																																																																																				
37	H POSI TXT																																																																																				
38	V POSI TXT																																																																																				
39	H POSI 60																																																																																				

Fig. 1-2

### 2. BASIC ADJUSTMENTS

#### 2-1: AGC VOLTAGE

1. Place the set with Aging Test for more than 15 minutes.
2. Receive the UHF (63dB).
3. Connect the digital voltmeter between the pin 5 and pin 1 (GND) of CP101.
4. Activate the adjustment mode display of Fig. 1-1 and press the channel button (01) on the remote control to select "RF AGC".
5. Press the VOL. UP/DOWN button on the remote control until the voltmeter is  $1.85 \pm 0.05V$ .

#### 2-2: CUT OFF

1. Place the set with Aging Test for more than 15 minutes.
2. Activate the adjustment mode display of Fig. 1-1 and press the channel button (00) on the remote control to select "CUT OFF".
3. Adjust the Screen Volume until a dim raster is obtained.

#### 2-3: WHITE BALANCE

**NOTE:** Adjust after performing CUT OFF adjustment.

1. Place the set with Aging Test for more than 15 minutes.
2. Receive the white 100% signal from the Pattern Generator.
3. Using the remote control, set the brightness and contrast to normal position.
4. Activate the adjustment mode display of Fig. 1-1 and press the channel button (04) on the remote control to select "R CUT OFF".
5. Using the VOL. UP/DOWN button on the remote control, adjustment the R CUT OFF.
6. Press the CH. UP/DOWN button on the remote control to select the "R DRIVE", "G DRIVE", "G CUT OFF" or "B DRIVE".
7. Using the VOL. UP/DOWN button on the remote control, adjustment the R DRIVE, G DRIVE, G CUT OFF or B DRIVE.
8. Perform the above adjustments 6 and 7 until the white color is looked like a white.

#### 2-4: FOCUS

1. Receive the monoscope pattern.
2. Turn the Focus Volume fully counterclockwise once.
3. Adjust the Focus Volume until picture is distinct.

#### 2-5: CONSTANT VOLTAGE

1. Place the set with Aging Test for more than 15 minutes.
2. Using the remote control, set the brightness and contrast to normal position.
3. Connect the digital voltmeter to TP501.
4. Set condition is AV MODE without signal.
5. Adjust the VR501 until the digital voltmeter is  $130 \pm 1V$ .

## ELECTRICAL ADJUSTMENTS

### 2-6: HORIZONTAL POSITION

1. Receive the monoscope pattern.
2. Using the remote control, set the brightness and contrast to normal position.
3. Activate the adjustment mode display of Fig. 1-1 and press the channel button (08) on the remote control to select "H POSI(50)".
4. Press the VOL. UP/DOWN button on the remote control until the SHIFT quantity of the OVER SCAN on right and left becomes minimum.
5. Receive the monoscope pattern of NTSC.
6. Using the remote control, set the brightness and contrast to normal position.
7. Activate the adjustment mode display of Fig. 1-1 and press the channel button (39) on the remote control to select "H POSI(60)".
8. Press the VOL. UP/DOWN button on the remote control until the SHIFT quantity of the OVER SCAN on right and left becomes minimum.

### 2-7: VERTICAL LINEARITY

1. Receive the monoscope pattern.
2. Using the remote control, set the brightness and contrast to normal position.
3. Adjust the VR420 until the SHIFT quantity of the OVER SCAN on upside and downside becomes minimum.

### 2-8: VERTICAL SIZE

1. Receive the monoscope pattern.
2. Using the remote control, set the brightness and contrast to normal position.
3. Activate the adjustment mode display of Fig. 1-1 and press the channel button (11) on the remote control to select "V SIZE(50)".
4. Press the VOL. UP/DOWN button on the remote control until the SHIFT quantity of the OVER SCAN on upside and downside becomes  $8 \pm 3\%$ .
5. Receive the monoscope pattern of NTSC.
6. Using the remote control, set the brightness and contrast to normal position.
7. Activate the adjustment mode display of Fig. 1-1 and press the channel button (12) on the remote control to select "V SIZE(60)".
8. Press the VOL. UP/DOWN button on the remote control until the SHIFT quantity of the OVER SCAN on upside and downside becomes  $8 \pm 3\%$ .

### 2-9: HORIZONTAL POSITION OSD

1. Receive the monoscope pattern.
2. Activate the adjustment mode display of Fig. 1-1. Press the VOL. UP/DOWN button on the remote control
3. until then difference of A and B becomes minimum. (Refer to Fig. 2-1)

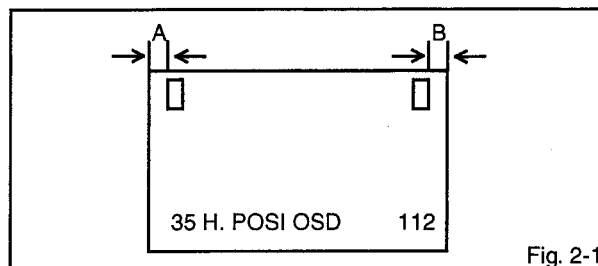

Fig. 2-1

### 2-10: BRIGHT CENT

1. Place the set with Aging Test for more than 15 minutes.
2. Receive the monoscope Pattern. (RF Input)
3. Using the remote control, set the brightness and contrast to normal position.
4. Activate the adjustment mode display of Fig. 1-1 and press the channel button (17) on the remote control to select "BRIGHT CENT".
5. Press the VOL. UP/DOWN button on the remote control until the white 25% is starting to be visible.
6. Receive the monoscope Pattern. (Audio Video Input)
7. Press the AV button on the remote control to set to the AV mode. Then perform the above adjustments 3-5.

### 2-11: CONT CENT

1. Activate the adjustment mode display of Fig. 1-1 and press the channel button (22) on the remote control to select "CONT CENT".
2. Press the VOL. UP/DOWN button on the remote control until the contrast step No. becomes "40".
3. Press the AV button on the remote control to set to the AV mode. Then perform the above adjustments 1, 2.

### 2-12: COLOR CENT

1. Receive the monoscope Pattern. (RF Input)
2. Connect the oscilloscope to TP022.
3. Using the remote control, set the brightness and contrast to normal position.
4. Activate the adjustment mode display of Fig. 1-1 and press the channel button (25) on the remote control to select "COLOR CENT".
5. Adjust the VOLTS RANGE VARIABLE knob of the oscilloscope until the range between white 100% and 0% is set to 5 scales on the screen of the oscilloscope.
6. Press the VOL. UP/DOWN button on the remote control until the red color level is adjusted to  $85 \pm 10\%$  for the white level. (Refer to Fig. 2-2)
7. Receive the monoscope Pattern. (Audio Video Input)
8. Press the AV button on the remote control to set to the AV mode. Then perform the above adjustments 2-6.

## ELECTRICAL ADJUSTMENTS

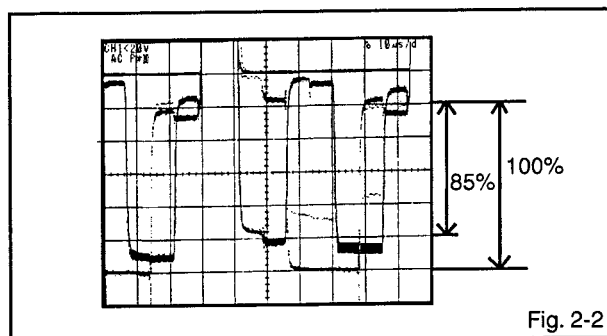

Fig. 2-2

### 2-13: VCO COARSE/VCO FINE

1. Place the set with Aging Test for more than 10 minutes.
2. Connect the oscillator (38.9MHz) to TP001.
3. Activate the adjustment mode display of Fig. 1-1 and press the channel button (13) on the remote control to select "VCO COARSE".
4. Press the VOL. UP/DOWN button on the remote control until the "OK" appear on the screen. If the "OK" is not displayed, select the "-" side on the changed from "+" to "-".
5. Press the CH UP button once to set to "VCO FINE" mode.
6. Press the VOL. UP/DOWN button on the remote control to select the 4 step down point from the upper limit on the "OK".  
(Example: In sace of the "OK" point 30~41, select 37.)

### 2-14: VERTICAL POSITION

1. Receive the monoscope pattern.
2. Using the remote control, set the brightness and contrast to normal position.
3. Activate the adjustment mode display of Fig. 1-1 and press the channel button (09) on the remote control to select "V POSI(50)".
4. Press the VOL. UP/DOWN button on the remote control until the SHIFT quantity of the OVER SCAN on right and left becomes minimum.
5. Receive the monoscope pattern of NTSC.
6. Using the remote control, set the brightness and contrast to normal position.
7. Activate the adjustment mode display of Fig. 1-1 and press the channel button (10) on the remote control to select "V POSI(60)".
8. Press the VOL. UP/DOWN button on the remote control until the SHIFT quantity of the OVER SCAN on right and left becomes minimum.

### 2-15: Confirmation of Fixed Value (step No.)

Please check if the fixed values of the each adjustment items are set correctly referring below.

NO.	FUNCTION	RF	AV
02	AGC GAIN	00	00
08	BRIGHT MAX	30	30
19	BRIGHT MIN	00	00
20	TINT	32	32
21	SHARP	10	10
23	CONT MAX	50	50
24	CONT MIN	01	01
26	COLOR MAX	45	45
27	COLOR MIN	14	14
31	CVBS OUT	08	08
32	APR THR	04	04
33	BELL	10	10
34	BANDPASS	06	06
36	V POSI OSD	50	50
37	H POSI TXT	115	115
38	V POSI TXT	60	60

## ELECTRICAL ADJUSTMENTS

### 3. PURITY AND CONVERGENCE ADJUSTMENTS

#### NOTE

1. Turn the unit on and let it warm up for at least 30 minutes before performing the following adjustments.
2. Place the CRT surface facing east or west to reduce the terrestrial magnetism.
3. Turn ON the unit and demagnetize with a Degauss Coil.

#### 3-1: STATIC CONVERGENCE (ROUGH ADJUSTMENT)

1. Tighten the screw for the magnet. Refer to the adjusted CRT for the position. (Refer to Fig. 3-1)  
If the deflection yoke and magnet are in one body, untighten the screw for the body.
2. Receive the green raster pattern from the color bar generator.
3. Slide the deflection yoke until it touches the funnel side of the CRT.
4. Adjust center of screen to green, with red and blue on the sides, using the pair of purity magnets.
5. Switch the color bar generator from the green raster pattern to the crosshatch pattern.
6. Combine red and blue of the 3 color crosshatch pattern on the center of the screen by adjusting the pair of 4 pole magnets.
7. Combine red/blue (magenta) and green by adjusting the pair of 6 pole magnets.
8. Adjust the crosshatch pattern to change to white by repeating steps 6 and 7.

#### 3-2: PURITY

#### NOTE

Adjust after performing adjustments in section 3-1.

1. Receive the green raster pattern from color bar generator.
2. Adjust the pair of purity magnets to center the color on the screen.  
Adjust the pair of purity magnets so the color at the ends are equally wide.
3. Move the deflection yoke backward (to neck side) slowly, and stop it at the position when the whole screen is green.
4. Confirm red and blue colors.
5. Adjust the slant of the deflection yoke while watching the screen, then tighten the fixing screw.

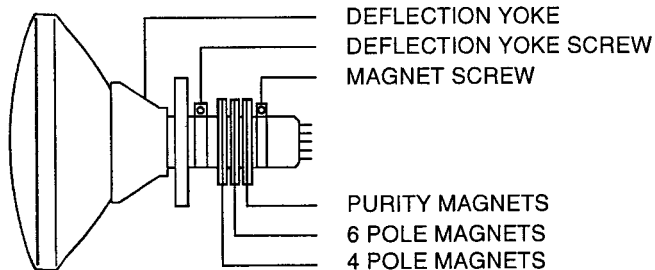

Fig. 3-1

#### 3-3: STATIC CONVERGENCE

#### NOTE

Adjust after performing adjustments in section 3-2.

1. Receive the crosshatch pattern from color bar generator.
2. Combine red and blue of the 3 color crosshatch pattern on the center of the screen by adjusting the pair of 4 pole magnets.
3. Combine red/blue (magenta) and green by adjusting the pair of 6 pole magnets.

#### 3-4: DYNAMIC CONVERGENCE

#### NOTE

Adjust after performing adjustments in section 3-3.

1. Adjust the differences around the screen by moving the deflection yoke upward/downward and right/left. (Refer to Fig. 3-2-a)
2. Insert three wedges between the deflection yoke and CRT funnel to fix the deflection yoke. (Refer to Fig. 3-2-b)

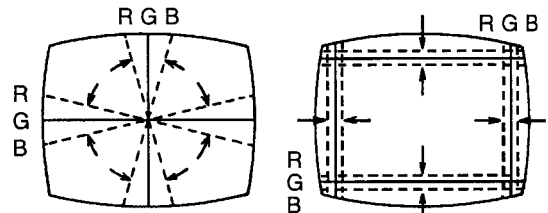

UPWARD/DOWNWARD SLANT    RIGHT/LEFT SLANT

Fig. 3-2-a

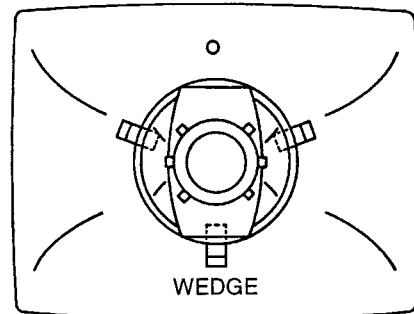

WEDGE POSITION

Fig. 3-2-b

# MAJOR COMPONENTS LOCATION GUIDE

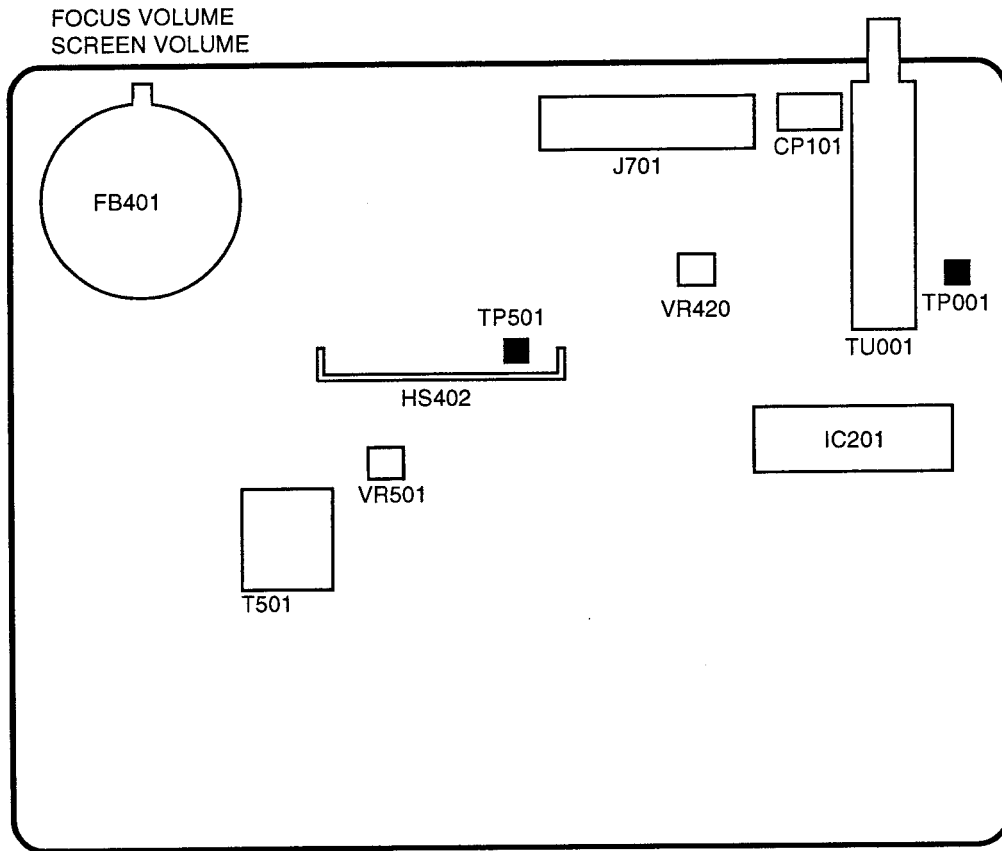

MAIN PCB

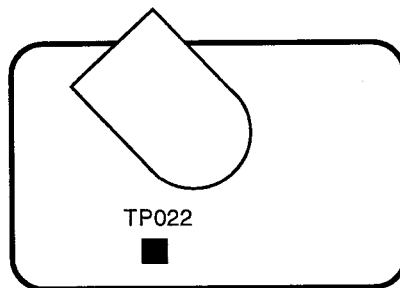

CRT PCB

# BLOCK DIAGRAM

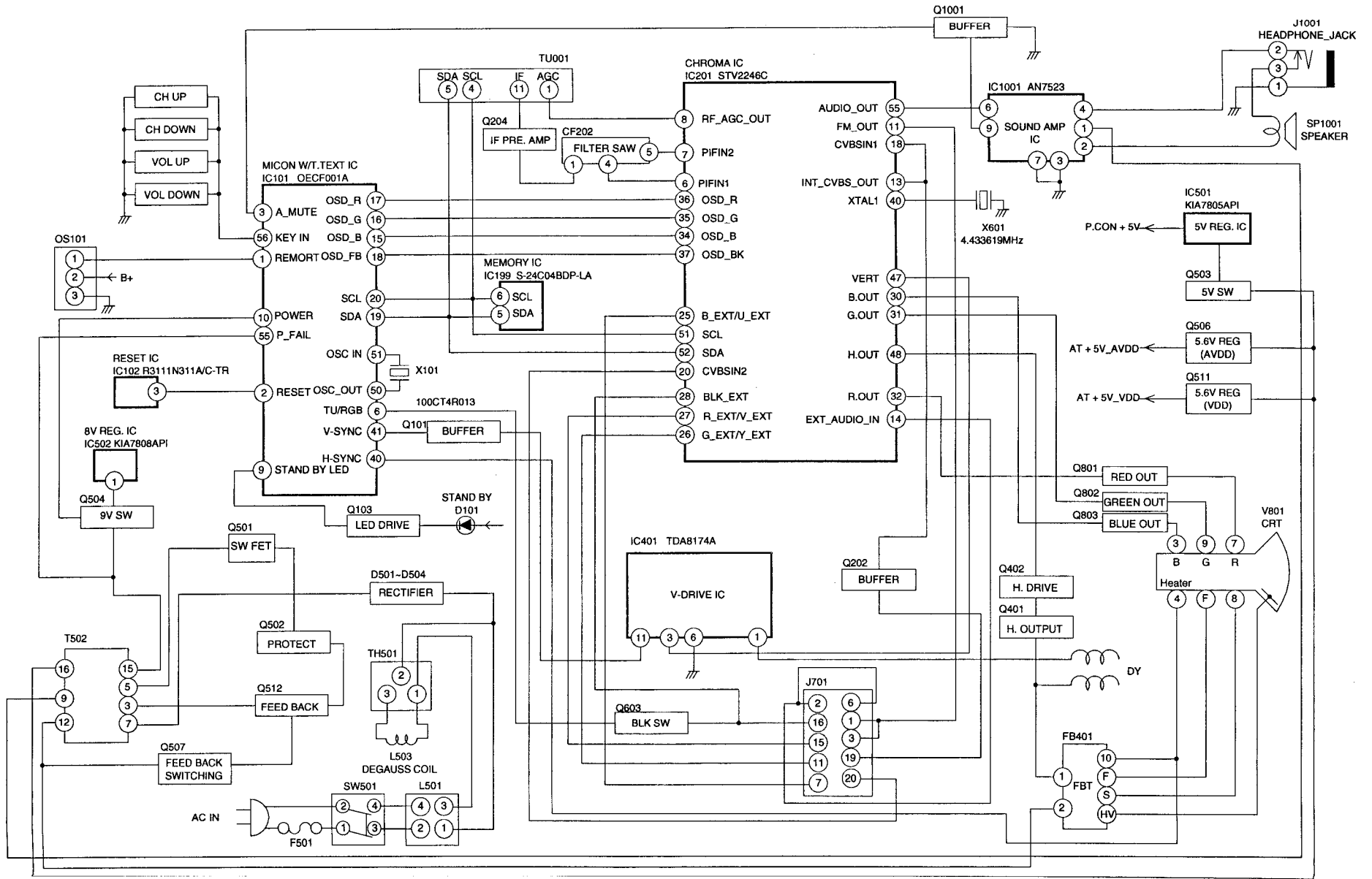



PRINTED CIRCUIT BOARDS  
MAIN/CRT (INSERTED PARTS)  
SOLDER SIDE

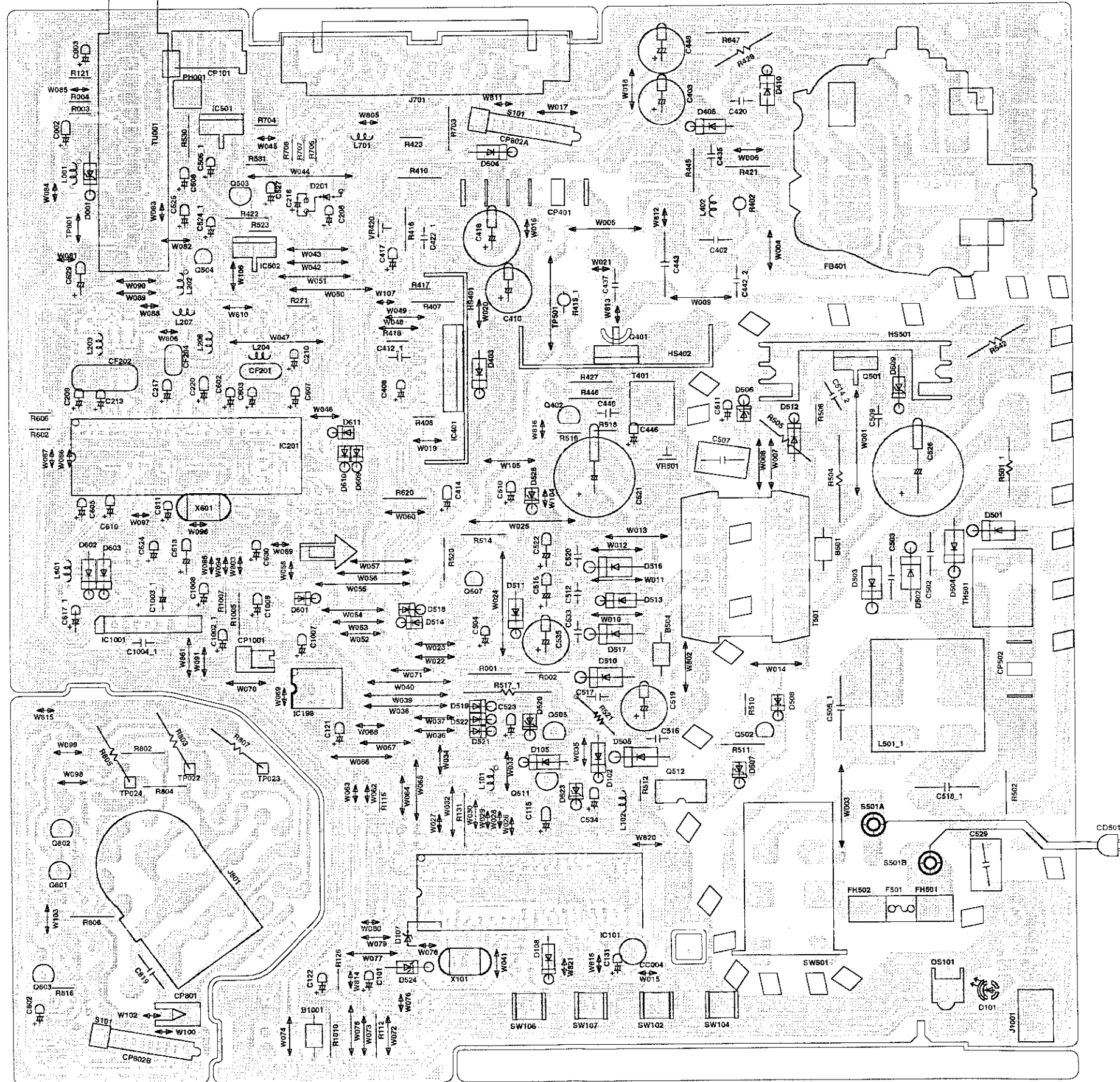

PRINTED CIRCUIT BOARDS  
MAIN/CRT (CHIP MOUNTED PARTS)  
SOLDER SIDE

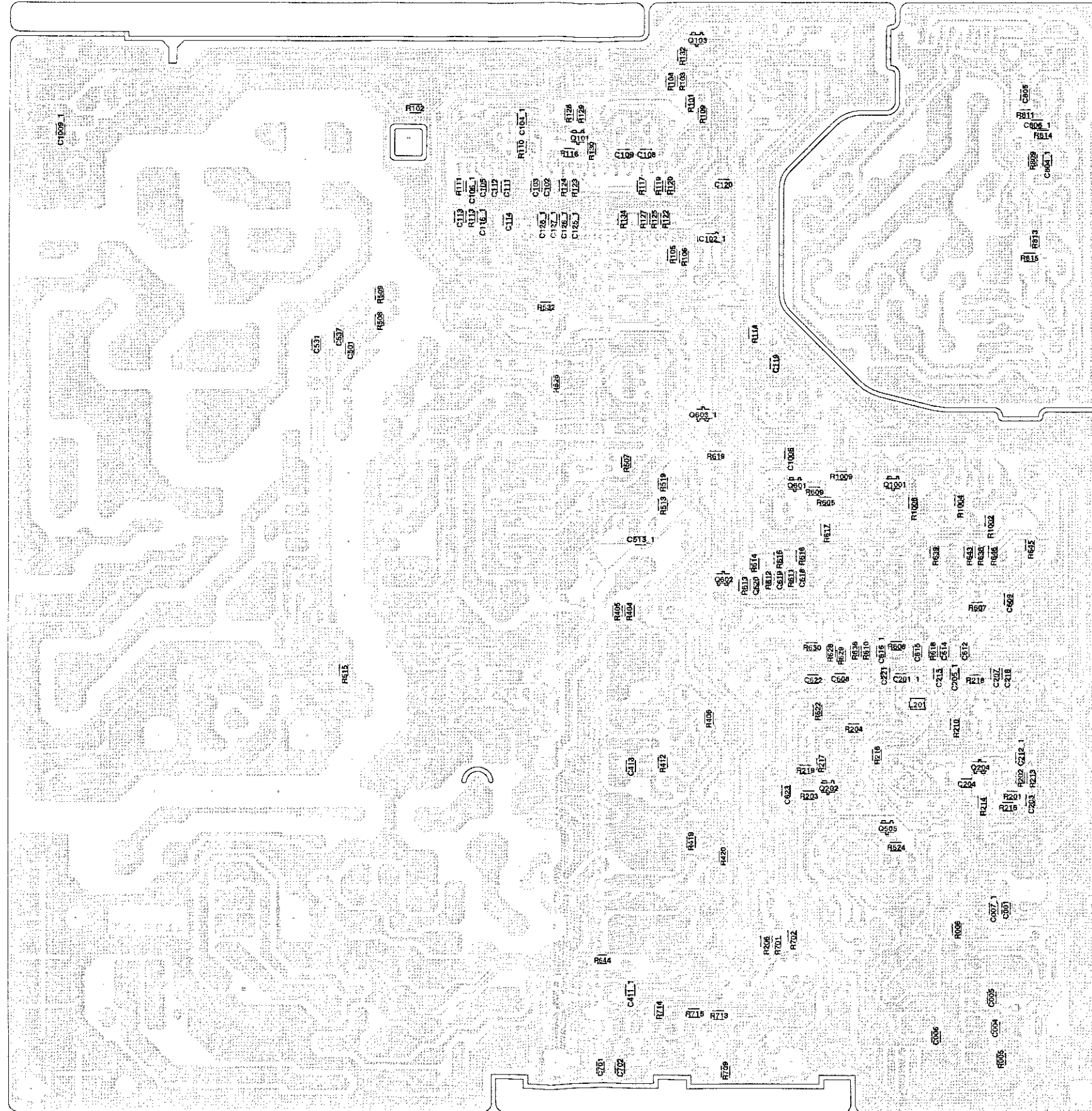

# MICON/T.TEXT/TUNER SCHEMATIC DIAGRAM (MAIN PCB)

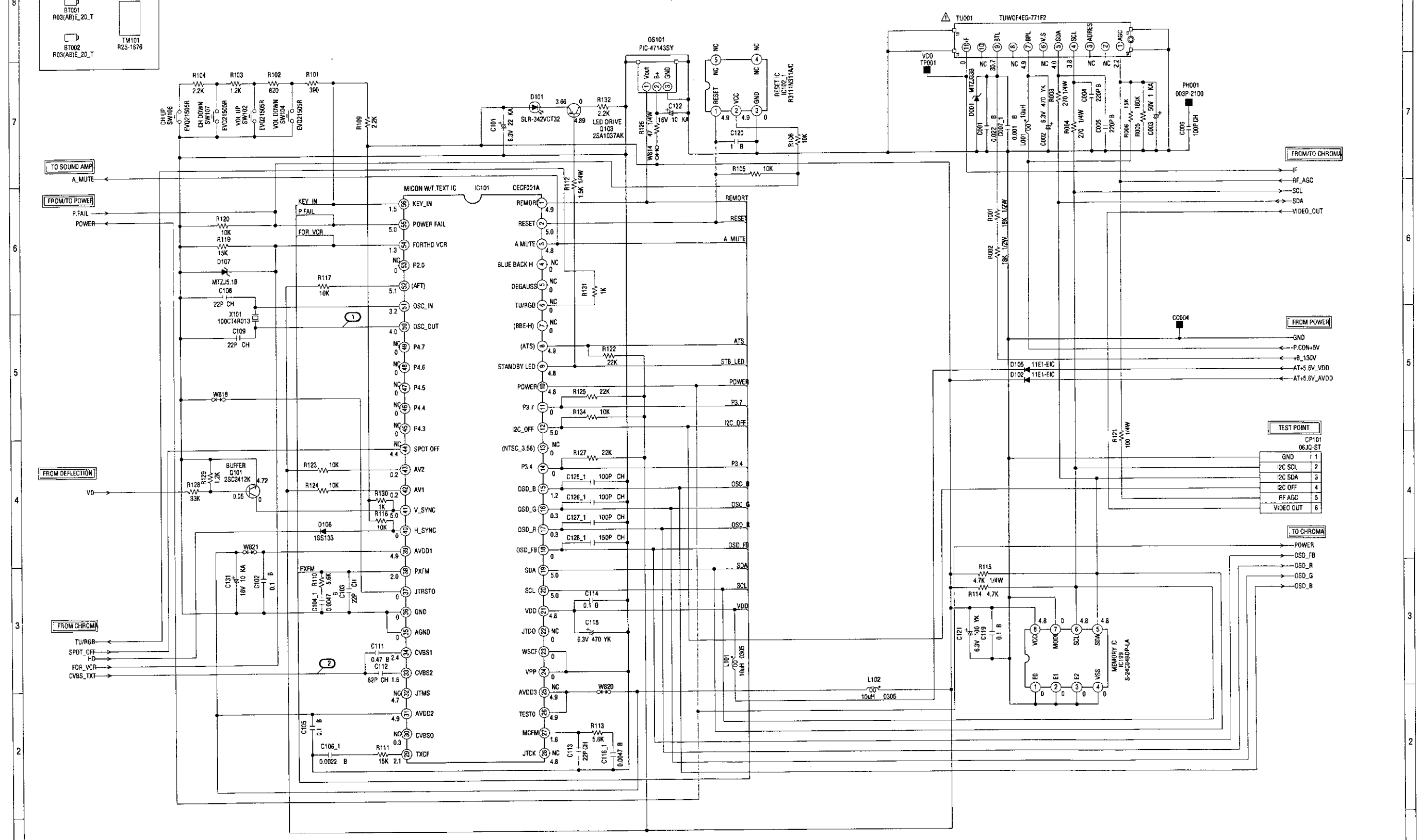

NOTE: THIS SCHEMATIC DIAGRAM IS THE LATEST AT THE TIME OF PRINTING AND SUBJECT TO CHANGE WITHOUT NOTICE.

NOTE: THE DC VOLTAGE AT EACH PART WAS MEASURED WITH THE DIGITAL TESTER WHEN THE COLOR BROADCAST WAS RECEIVED IN GOOD CONDITION AND PICTURE IS NORMAL.

NOTE: THE DC VOLTAGE AT EACH PART WAS MEASURED WITH THE DIGITAL TESTER WHEN THE COLOR BROADCAST WAS RECEIVED IN GOOD CONDITION AND PICTURE IS NORMAL.

NOTE: THE DC VOLTAGE AT EACH PART WAS MEASURED WITH THE DIGITAL TESTER WHEN THE COLOR BROADCAST WAS RECEIVED IN GOOD CONDITION AND PICTURE IS NORMAL.

PCB010  
TMA504



# POWER SCHEMATIC DIAGRAM (MAIN PCB)

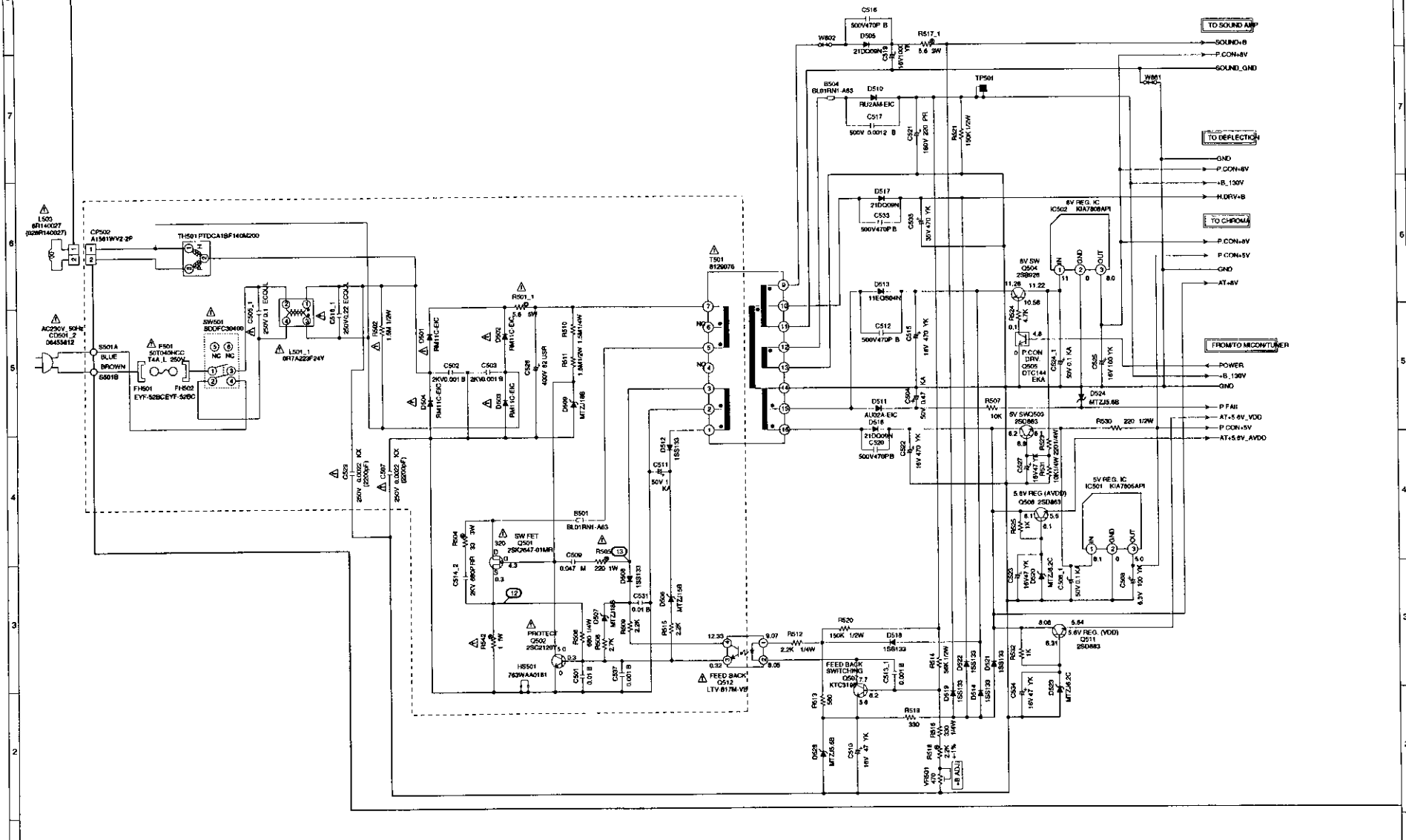

CAUTION: DIGITAL TRANSISTOR

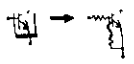

ATTENTION: LES PIÈCES RÉPARÉES PAR LA MAIN D'ŒUVRE DOIVENT ÊTRE IDENTIFIÉES DANS LA NOMENCLATURE DES PIÈCES

CAUTION: SINCE THESE PARTS MARKINGS ARE CRITICAL FOR SAFETY, USE CARE

NOTES: THIS SCHEMATIC DIAGRAM IS THE LATEST AT THE TIME OF PRINTING AND SUBJECT TO CHANGE WITHOUT NOTICE

NOTES: THIS SCHEMATIC DIAGRAM IS THE LATEST AT THE TIME OF PRINTING AND SUBJECT TO CHANGE WITHOUT NOTICE

PC2010  
TMA504

# DEFLECTION/CRT SCHEMATIC DIAGRAM (PCB)

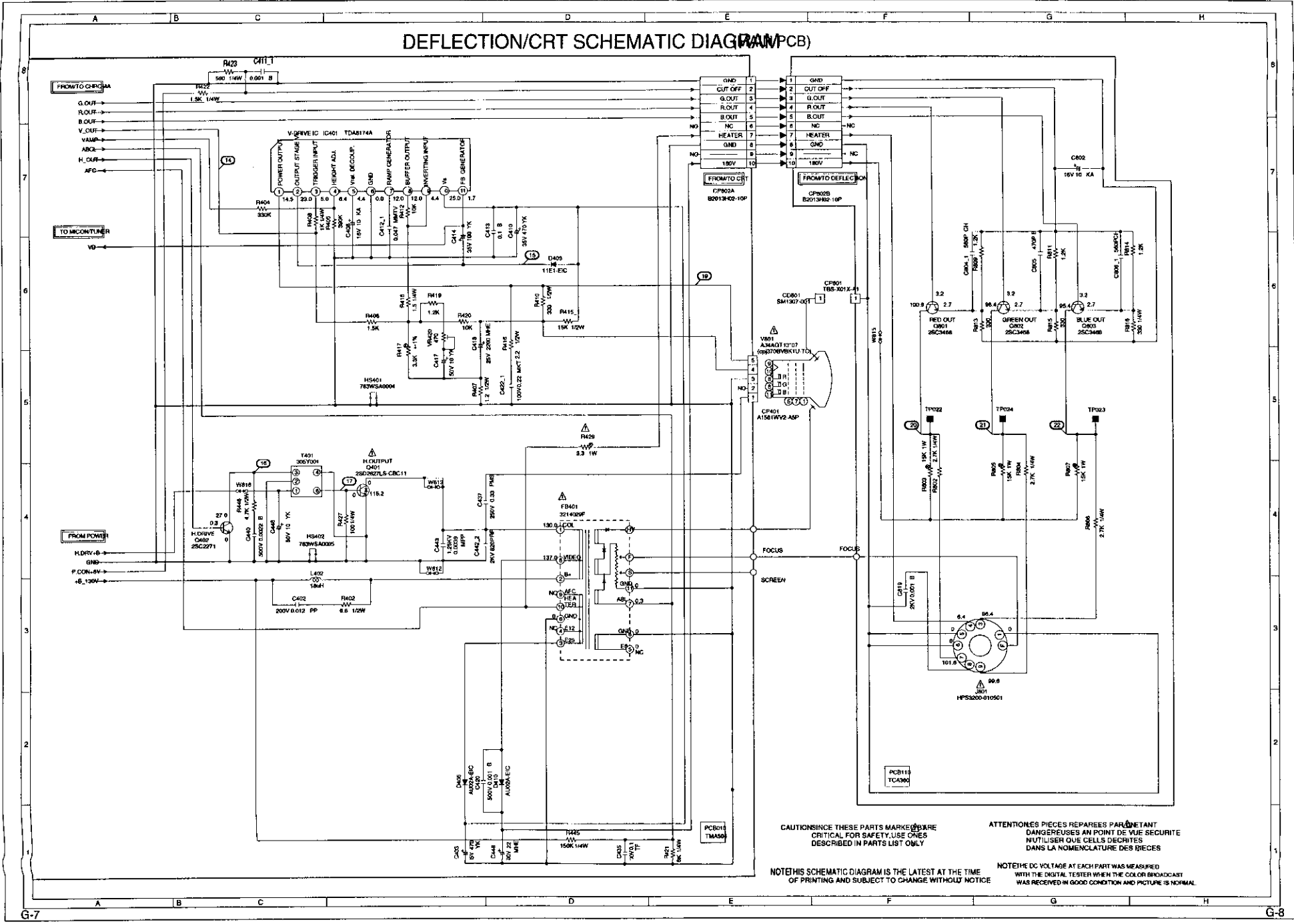

CAUTION: THESE PARTS MARKED WITH A TRIANGLE ARE CRITICAL FOR SAFETY. USE ONES DESCRIBED IN PARTS LIST ONLY.

ATTENTION: LES PIÈCES REPAREES PAR UN ETANT DANGEREUSES AN POINT DE VUE SECURITE. UTILISER CES CELLIS DECRITES DANS LA NOMENCLATURE DES PIÈCES.

NOTE: THIS SCHEMATIC DIAGRAM IS THE LATEST AT THE TIME OF PRINTING AND SUBJECT TO CHANGE WITHOUT NOTICE.

NOTE: THE DC VOLTAGE AT EACH PART WAS MEASURED WITH THE DIGITAL TESTER WHEN THE COLOR BROADCAST WAS RECEIVED IN GOOD CONDITION AND PICTURE IS NORMAL.



# WAVEFORMS

## MICON/T.TEXT/TUNER

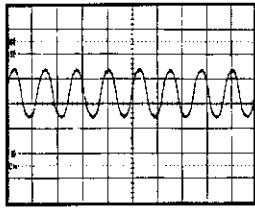

① 5V. 200ns/div

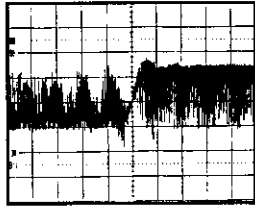

② 5V. 200ns/div

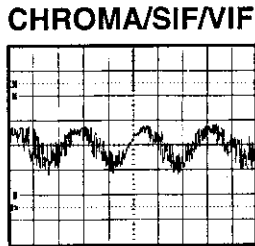

③ 10V 10ns/div

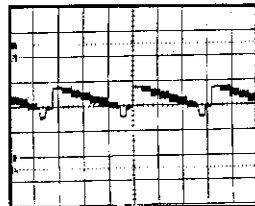

④ 10V. 20μs/div

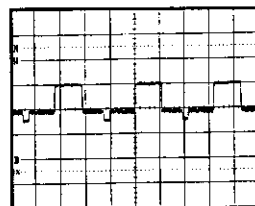

⑤ 5V. 20μs/div

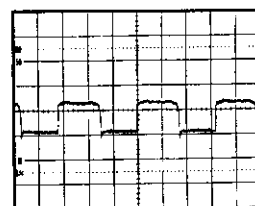

⑥ 5V. 20μs/div

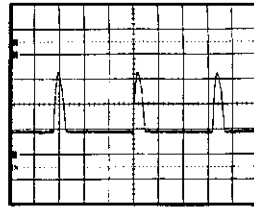

⑦ 100V 20μs/div

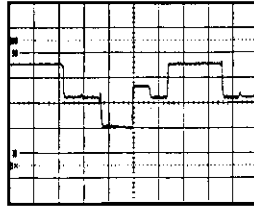

⑨ 10V 10μs/div

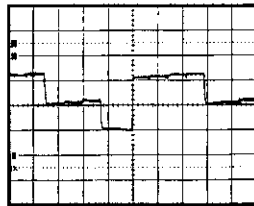

⑩ 10V 10μs/div

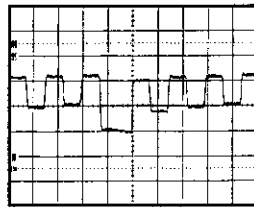

⑪ 10V 10μs/div

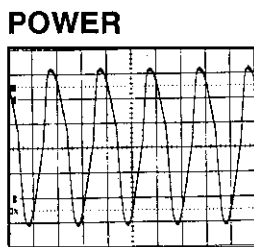

⑫ 500V 10ms/div

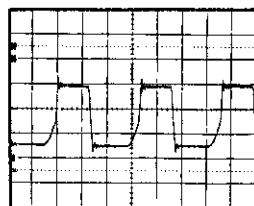

⑬ 100V 5μs/div

## DEFLECTION/CRT

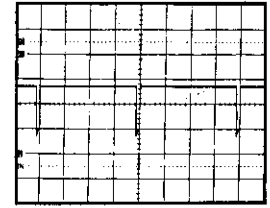

⑭ 20V 5ms/div

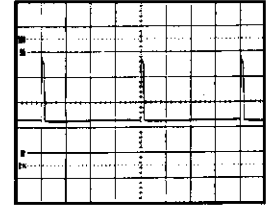

⑮ 100V 5ms/div

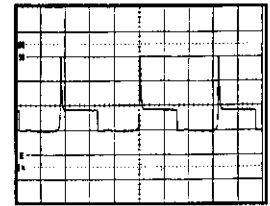

⑯ 500V 20μs/div

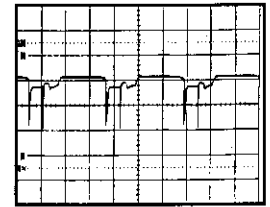

⑰ 50V 20μs/div

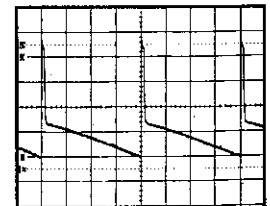

⑱ 100V 5ms/div

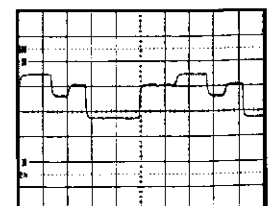

⑳ 500V 10μs/div

NOTE: The following waveforms were measured at the point of the corresponding balloon number in the schematic diagram.



# WAVEFORMS

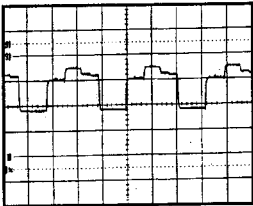

②1 500V 20µs/div

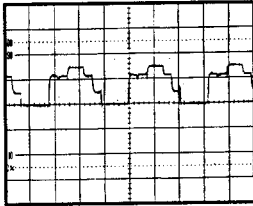

②2 50V 20µs/div

**NOTE:** The following waveforms were measured at the point of the corresponding balloon number in the schematic diagram.



## MECHANICAL REPLACEMENT PARTS LIST

REF. NO.	PART NO.	DESCRIPTION
101	A3K312M720	CABINET,FRONT ASSY
102	701WPJB534	CABINET,FRONT
103	735WPBA349	BUTTON,FRAME
104	761WPA0163	HOLDER,PCB
105	722202A572	SHEET,RATING
106	800WQ00044	FELT SHEET
107	735WPBA351	BUTTON,POWER
108	713WPAA055	GLASS,LED
109	713WPAA054	GUIDE,REMOCON
110	735WPAA416	BUTTON,HOLDER
111	702UPA0118	CABINET,BACK
112	741WUA0020	SPRING,EARTH
113	752WSA0216	SHIELD,CASE
114	7220001017	SHEET,PTB
201	8110630A04	SCREW,TAP TITE(P)      BRAZIER    3x10
202	8109130804	SCREW,TAP TITE(B)      WH7        3x8
203	8109630802	SCREW,TAP TITE(B)      BRAZIER    3x8
204	8117540A64	SCREW,TAPPING(B0)      TRUSS      4x16
205	8121F50B84	SCREW,TAPPING(B0)      FAI20 FLAT 5x28
---	793UCDA888	GIFT BOX
---	A3K302N975	INSTRUCTION BOOK KIT
---	JB5X0100	POLYBAG
---	J3K30201	INSTRUCTION BOOK
---	791MHA0001	LAMIFILM BAG
---	792UHA0114	PACKAGE, TOP
---	792UHA0115	PACKAGE, BOTTOM

# ELECTRICAL REPLACEMENT PARTS LIST

REF. NO.	PART NO.	DESCRIPTION	REF. NO.	PART NO.	DESCRIPTION
<b>RESISTORS</b>			<b>ICs</b>		
R429	R655813R3J	R,FUSE 3.3 OHM 1W	IC102	IC7J0311A0	IC R311N311A/C-TR
△ R501	R5Y2CD5R6J	R,CEMENT 5.6 OHM 5W	IC199	A3K312N015	IC S-24C04BDP-LA
△ R502	R002T2155J	RC 1.5M OHM 1/2W	IC201	I0WDE246C0	IC STV2246C
R504	R3X28B330J	R,METAL OXIDE 33 OHM 3W	IC401	I0WTD81740	IC TDA8174A
△ R505	R3X181221J	R,METAL OXIDE 220 OHM 1W	IC501	I1KA97805A	IC KIA7805API
R517	R3X28B5R6J	R,METAL OXIDE 5.6 OHM 3W	IC502	I1KA97808A	IC KIA7808API
R521	R00202154J	RC 150K OHM 1/2W	IC1001	I0FSP75230	IC AN7523
△ R542	R3X181010J	R,METAL OXIDE 1 OHM 1W	<b>TRANSISTORS</b>		
R803	R3X181153J	R,METAL OXIDE 15K OHM 1W	Q101	T8YJ2412K0	TRANSISTOR SILICON 2SC2412KT146 R,S
R805	R3X181153J	R,METAL OXIDE 15K OHM 1W	Q103	T6YJ1037K0	TRANSISTOR,SILICON 2SA1037AKT146R,S
R807	R3X181153J	R,METAL OXIDE 15K OHM 1W	Q202	T8YJ2412K0	TRANSISTOR SILICON 2SC2412KT146 R,S
<b>CAPACITORS</b>			Q204	T83A028140	TRANSISTOR,SILICON 2SC2814(F3,F4)-T
C216	E02L05220M	CE 22 UF 50V	△ Q401	TD30026270	TRANSISTOR SILICON 2SD2627LS-CBC11
	E02LU5220M	CE 22 UF 50V	Q402	TC3T022710	TRANSISTOR,SILICON 2SC2271(D,E)-AE
C402	P3N1F2123J	CPP 0.012 UF 200V	△ Q501	T410K26470	FET 2SK2647-01MR
C418	E5EZFC222M	CE 2200 UF 25V	△ Q502	TC5T021204	TRANSISTOR,SILICON 2SC2120Y(TPE2)
C437	P4J7F3334J	CMPP 0.33 UF 250V PMS	Q503	TD3T008630	TRANSISTOR,SILICON 2SD863(E,F)-AE
C442	COPLRR7W2K	CC 820 PF 2KV RR	Q504	TBWT009260	TRANSISTOR,SILICON 2SB926(S,T)-AA
	CO3L0R7W2K	CC 820 PF 2KV R	Q505	TNYJD05001	COMPOUND TRANSISTOR DTC144EKAT146
C443	P4N8FJ392H	CMPP 0.0039UF 1.25KV	Q506	TD3T008630	TRANSISTOR,SILICON 2SD863(E,F)-AE
C448	E5EZFC220M	CE 22 UF 200V	Q507	TCATC31980	TRANSISTOR,SILICON KTC3198-AT(Y,GR)
C502	COJBB0713K	CC 0.001 UF 2KV B	Q511	TD3T008630	TRANSISTOR,SILICON 2SD863(E,F)-AE
C503	COJBB0713K	CC 0.001 UF 2KV B	△ Q512	0002E00610	PHOTO COUPLER LTV-817M-VB
△ C505	P2122B104M	CMP 0.1 UF 250V ECQUL	Q601	TNYJD05001	COMPOUND TRANSISTOR DTC144EKAT146
△ C507	CB3C30MH3M	CC 0.0022UF 250V	Q602	T8YJ2412K0	TRANSISTOR SILICON 2SC2412KT146 R,S
C514	COPLRR7U2K	CC 680 PF 2KV RR	Q603	T8YJ2412K0	TRANSISTOR SILICON 2SC2412KT146 R,S
	CO3L0R7U2K	CC 680 PF 2KV R	Q801	TC3T034680	TRANSISTOR,SILICON 2SC3468(D,E)-AE
△ C518	P2122B224M	CMP 0.22 UF 250V ECQUL	Q802	TC3T034680	TRANSISTOR,SILICON 2SC3468(D,E)-AE
C521	E53VFB221M	CE 220 UF 160V	Q803	TC3T034680	TRANSISTOR,SILICON 2SC3468(D,E)-AE
C526	E52D0H820M	CE 82 UF 400V	Q1001	T8YJ2412K0	TRANSISTOR SILICON 2SC2412KT146 R,S
△ C529	CB3C30MH3M	CC 0.0022UF 250V	<b>COILS &amp; TRANSFORMERS</b>		
C819	COJBB0713K	CC 0.001 UF 2KV B	L001	02167F100J	COIL 10 UH
<b>DIODES</b>			L101	02167F100J	COIL 10 UH
D001	D97U03301B	DIODE,ZENER MTZJ33B T-77	L102	02167F100J	COIL 10 UH
D101	0021721150	LED SLR-342VCT32	L201	0216S1R56J	COIL 0.56 UH
D102	D2WT011E10	DIODE SILICON 11E1-EIC	L202	0216733R3K	COIL 3.3 UH
D105	D2WT011E10	DIODE SILICON 11E1-EIC	L203	021LA62R2M	COIL 2.2 UH
D107	D97U05R11B	DIODE,ZENER MTZJ5.1B T-77	L204	021LA6180K	COIL 18 UH
D108	D1VT001330	DIODE,SILICON 1SS133T-77	L206	021LA6R27M	COIL 0.27 UH
D201	D1VT001330	DIODE,SILICON 1SS133T-77	L207	021LA6100J	COIL 10 UH
D403	D2WT011E10	DIODE SILICON 11E1-EIC	L402	021U6D180K	COIL 18 UH
D405	D2WTAU02A0	DIODE SILICON AU02A-EIC	△ L501	029T000094	COIL,LINE FILTER 0R7A223F24Y
D410	D2WTAU02A0	DIODE SILICON AU02A-EIC	△ L503	028R140027	COIL,DEGAUSS 8R140027
△ D501	D2WTRM11C0	DIODE SILICON RM11C-EIC	L601	02167F100J	COIL 10 UH
△ D502	D2WTRM11C0	DIODE SILICON RM11C-EIC	L701	021LA6100K	COIL 10 UH
△ D503	D2WTRM11C0	DIODE SILICON RM11C-EIC	T401	03305Y0018	TRANS,HORIZONTAL DRIVE 305Y001
△ D504	D2WTRM11C0	DIODE SILICON RM11C-EIC	△ T501	0481290766	TRANSFORMER,SWITCHING 8129076
D505	D28T21DQ9N	DIODE SCHOTTKY 21DQ09N-TA2B1	<b>JACKS</b>		
D506	D97U01501B	DIODE,ZENER MTZJ15B T-77	J701	063G100042	SOCKET,21PIN 0350_9982_05
D507	D97U01801B	DIODE,ZENER MTZJ18B T-77	△ J801	066X120014	SOCKET,CATHODE RAY TUBE HPS3200-010501
D508	D1VT001330	DIODE,SILICON 1SS133T-77	J1001	0602121012	JACK,RCA 3.5 HSJ1403-01-010
D509	D97U01801B	DIODE,ZENER MTZJ18B T-77	<b>SWITCHES</b>		
D510	D2WXRU2A00	DIODE SILICON RU2AM-EIC	SW102	0504101T34	SWITCH,TACT EVQ21505R
D511	D2WTAU02A0	DIODE SILICON AU02A-EIC	SW104	0504101T34	SWITCH,TACT EVQ21505R
D512	D1VT001330	DIODE,SILICON 1SS133T-77	SW106	0504101T34	SWITCH,TACT EVQ21505R
D513	D28TQS04N0	DIODE SCHOTTKY 11EQS04N-TA1B2	SW107	0504101T34	SWITCH,TACT EVQ21505R
D514	D1VT001330	DIODE,SILICON 1SS133T-77	△ SW501	0530205002	SWITCH PLUS SDDFC30400
D516	D28T21DQ9N	DIODE SCHOTTKY 21DQ09N-TA2B1	<b>VARIABLE RESISTORS</b>		
D517	D28T21DQ9N	DIODE SCHOTTKY 21DQ09N-TA2B1	VR420	V1163Q2BTC	VOLUME,SEMI FIXED EVNCYAA03B02
D518	D1VT001330	DIODE,SILICON 1SS133T-77	VR501	V1163Q2BTC	VOLUME,SEMI FIXED EVNCYAA03B02
D519	D1VT001330	DIODE,SILICON 1SS133T-77	<b>P.C. BOARD ASSEMBLIES</b>		
D520	D97U06R21C	DIODE,ZENER MTZJ6.2C T-77	PCB010	A3K312M010K	PCB ASSY TMA504A
D521	D1VT001330	DIODE,SILICON 1SS133T-77	PCB110	A3K302M110K	PCB ASSY TCA360A
D522	D1VT001330	DIODE,SILICON 1SS133T-77	<b>MISCELLANEOUS</b>		
D523	D97U06R21C	DIODE,ZENER MTZJ6.2C T-77	B501	024AT03655	CORE BEADS BL01RN1-A63T0
D524	D97U05R61B	DIODE,ZENER MTZJ5.6B T-77	B504	024AT03655	CORE BEADS BL01RN1-A63T0
D528	D97U05R61B	DIODE,ZENER MTZJ5.6B T-77	B1001	024AT03655	CORE BEADS BL01RN1-A63T0
D601	D1VT001330	DIODE,SILICON 1SS133T-77	BT001	1412004008	BATTERY,MANGAN R03(AB)E_20_T
D602	D2WT011E10	DIODE SILICON 11E1-EIC	BT002	1412004008	BATTERY,MANGAN R03(AB)E_20_T
D603	D2WT011E10	DIODE SILICON 11E1-EIC	△ CD501	1206455812	CORD AC BUSH 6455812
D604	D2WT011E10	DIODE SILICON 11E1-EIC	CD801	1278140027	BRAIDED WIRE SM1307-001
D609	D1VT001330	DIODE,SILICON 1SS133T-77	CF201	1012T5R503	FILTER,CERAMIC TRAP TPS5.5MB-TF2
D610	D1VT001330	DIODE,SILICON 1SS133T-77	CF202	1022038R9E	FILTER,SAW SAFGP38M9VA<Z00B or
D611	D1VT001330	DIODE,SILICON 1SS133T-77		1022T38R9E	FILTER,SAW SAF38.9MAK22Z
<b>ICs</b>			CF204	1012T04001	FILTER,CERAMIC TRAP MKT40.4MA11C-TF
IC101	I5PD0F001A	IC OECF001A	CP101	069X160379	CONNECTOR PCB SIDE 06JQ-ST

## ELECTRICAL REPLACEMENT PARTS LIST

REF. NO.	PART NO.	DESCRIPTION	
<b>MISCELLANEOUS</b>			
CP401	069S450089	CONNECTOR PCB SIDE	A1561WV2-A5P
CP502	069S420110	CONNECTOR PCB SIDE	A1561WV2-2P
CP801	069W010030	CONNECTOR PCB SIDE	TBS-X01X-A1
CP1001	069W120019	CONNECTOR PCB SIDE	TID-X02P-B2
CP802A	067U010049	WIRE HOLDER	B2013H02-10P
CP802B	067U010049	WIRE HOLDER	B2013H02-10P
EL002	124120301A	EYE LET	XRY20X30BD
△ F501	080NT04003	FUSE	50T040HCC
△ FB401	043214029F	TRANSFORMER FLYBACK	3214029F
FH501	06710T0006	HOLDER,FUSE	EYF-52BC
FH502	06710T0006	HOLDER,FUSE	EYF-52BC
OS101	077Q047001	REMOTE RECEIVER	PIC-47143SY
PH001	069W01001A	CONNECTOR PCB SIDE	003P-2100
S101	WHL6032038	FLAT CABLE	AWG26 10C BLACK 320MM
SP1001	070C732003	SPEAKER	SA08A05BWB or
	070W132016	SPEAKER	NS-300RW W/WIRE
TH501	DF20C140M0	DEGAUSS ELEMENT	PTDCA1BF140M200
TM101	076R0DG180	TRANSMITTER	R25-1676
TU001	0145511021	TUNER,VHF-UHF	TJWOF4EG-771F2
△ V801	098P140496	CRT W/DY	A34AGT13x07
X101	100CT4R013	CRYSTAL	HC-49/U-S
X601	100CT4R408	CRYSTAL	HC-49/U

### RESISTOR

RC..... CARBON RESISTOR

### CAPACITORS

CC..... CERAMIC CAPACITOR  
 CE..... ALUMI ELECTROLYTIC CAPACITOR  
 CP..... POLYESTER CAPACITOR  
 CPP..... POLYPROPYLENE CAPACITOR  
 CPL..... PLASTIC CAPACITOR  
 CMP..... METAL POLYESTER CAPACITOR  
 CMPL..... METAL PLASTIC CAPACITOR  
 CMPP..... METAL POLYPROPYLENE CAPACITOR

SPEC.NO.	M3K3-12M
O/R NO.	U1Z3501

# ORION

## TV-3787

# SERVICE MANUAL

**COLOR TELEVISION RECEIVER**

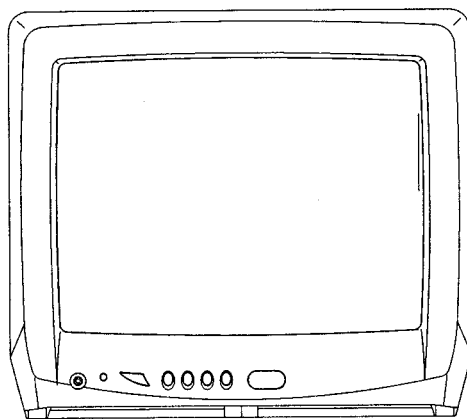

**SUPPLEMENT  
CHASSIS CODE A**

This SUPPLEMENT must be used together SERVICE MANUAL for TV-3786SI.  
All other test and repair procedures are as shown in the ORIGINAL MANUAL.  
Please file this SUPPLEMENT with the ORIGINAL VERSIONS.

## ELECTRICAL REPLACEMENT PARTS LIST

REF. NO.	TV-3786SI		TV-3787	
	PART NO.	DESCRIPTION	PART NO.	DESCRIPTION
BT001	1412004008	BATTERY,MANGAN R03(AB)E_20_T	1412004013	BATTERY,MANGAN R03(AB)2PXGPI
BT002	1412004008	BATTERY,MANGAN R03(AB)E_20_T	1412004013	BATTERY,MANGAN R03(AB)2PXGPI

## MECHANICAL REPLACEMENT PARTS LIST

REF. NO.	TV-3786SI		TV-3787	
	PART NO.	DESCRIPTION	PART NO.	DESCRIPTION
101	A3K312M720	CABINET,FRONT ASS'Y	A3K313M720	CABINET,FRONT ASS'Y
102	701WPJB534	CABINET,FRONT	701WPJB598	CABINET,FRONT
103	735WPBA349	BUTTON,FRAME	735WPAA429	BUTTON,FRAME
105	722202A572	SHEET,RATING	722202A585	SHEET,RATING
107	735WPBA351	BUTTON,POWER	735WPAA424	BUTTON,POWER
108	713WPAA055	GLASS,LED	713WPAA034	GLASS,LED
109	713WPAA054	GUIDE,REMOCON	713WPAA048	GUIDE,REMOCON
110	735WPAA416	BUTTON,HOLDER	735WPAA427	BUTTON,BASE
112	741WUA0020	SPRING,EARTH	741WUA0019	SPRING,EARTH
---	793UCDA888	GIFT BOX	793UCDA924	GIFT BOX
---	A3K302N975	INSTRUCTION BOOK KIT	A3K313N975	INSTRUCTION BOOK KIT
---	J3K30201	INSTRUCTION BOOK	J3K31301	INSTRUCTION BOOK
---	792UHA0114	PACKAGE, TOP	792UHAA021	PACKAGE, TOP
---	792UHA0115	PACKAGE, BOTTOM	792UHAA022	PACKAGE, BOTTOM

SPEC.NO.	M3K3-13M
O/R NO.	U223501



# ORION

## TV-3787SI

# SERVICE MANUAL

**COLOR TELEVISION RECEIVER**

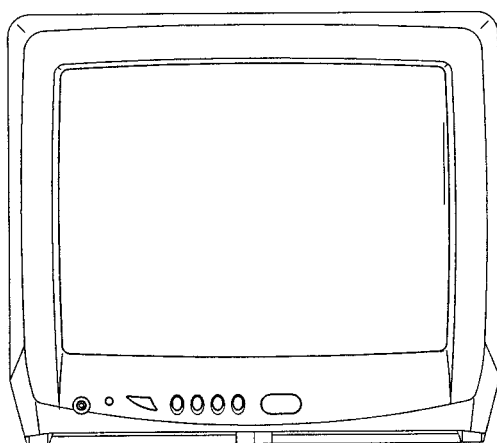

**SUPPLEMENT  
CHASSIS CODE A**

This SUPPLEMENT must be used together SERVICE MANUAL for TV-3786SI.  
All other test and repair procedures are as shown in the ORIGINAL MANUAL.  
Please file this SUPPLEMENT with the ORIGINAL VERSIONS.

## ELECTRICAL REPLACEMENT PARTS LIST

REF. NO.	TV-3786SI		TV-3787SI	
	PART NO.	DESCRIPTION	PART NO.	DESCRIPTION
BT001	1412004008	BATTERY,MANGAN R03(AB)E_20_T	1412004013	BATTERY,MANGAN R03(AB)2PXGPI
BT002	1412004008	BATTERY,MANGAN R03(AB)E_20_T	1412004013	BATTERY,MANGAN R03(AB)2PXGPI

## MECHANICAL REPLACEMENT PARTS LIST

REF. NO.	TV-3786SI		TV-3787SI	
	PART NO.	DESCRIPTION	PART NO.	DESCRIPTION
101	A3K312M720	CABINET,FRONT ASS'Y	A3K314M720	CABINET,FRONT ASS'Y
102	701WPJB534	CABINET,FRONT	701WPJB599	CABINET,FRONT
103	735WPBA349	BUTTON,FRAME	735WPBA345	BUTTON,FRAME
105	722202A572	SHEET,RATING	722202A586	SHEET,RATING
107	735WPBA351	BUTTON,POWER	735WPBA366	BUTTON,POWER
108	713WPAA055	GLASS,LED	713WPAA034	GLASS,LED
109	713WPAA054	GUIDE,REMOCON	713WPAA048	GUIDE,REMOCON
110	735WPAA416	BUTTON,HOLDER	735WPAA427	BUTTON,BASE
111	702UPA0118	CABINET,BACK	702UPAA026	CABINET,BACK
112	741WUA0020	SPRING,EARTH	741WUA0019	SPRING,EARTH
---	793UCDA888	GIFT BOX	793UCDA925	GIFT BOX
---	A3K302N975	INSTRUCTION BOOK KIT	A3K313N975	INSTRUCTION BOOK KIT
---	J3K30201	INSTRUCTION BOOK	J3K31301	INSTRUCTION BOOK
---	792UHA0114	PACKAGE, TOP	792UHAA021	PACKAGE, TOP
---	792UHA0115	PACKAGE, BOTTOM	792UHAA022	PACKAGE, BOTTOM

SPEC.NO.	M3K3-14M
O/R NO.	U223503