

# SERVICE MANUAL

## ORION

### TV-719 SI / TV-719

COLOR TELEVISION RECEIVER

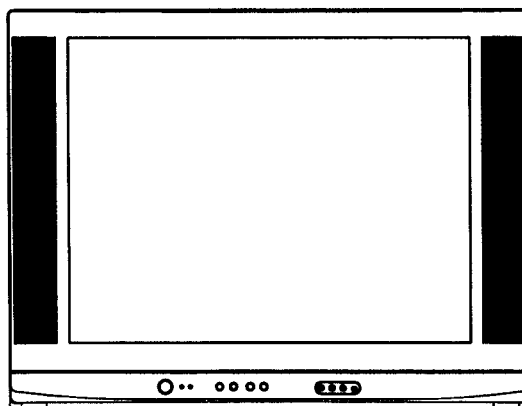

ORIGINAL  
CHASSIS CODE A

Best. Nr. SM719

---

Design and specifications are subject to change without notice.

## SERVICING NOTICES ON CHECKING

### 1. KEEP THE NOTICES

As for the places which need special attentions, they are indicated with the labels or seals on the cabinet, chassis and parts. Make sure to keep the indications and notices in the operation manual.

### 2. AVOID AN ELECTRIC SHOCK

There is a high voltage part inside. Avoid an electric shock while the electric current is flowing.

### 3. USE THE DESIGNATED PARTS

The parts in this equipment have the specific characters of incombustibility and withstand voltage for safety. Therefore, the part which is replaced should be used the part which has the same character.

Especially as to the important parts for safety which is indicated in the circuit diagram or the table of parts as a  $\triangle$  mark, the designated parts must be used.

### 4. PUT PARTS AND WIRES IN THE ORIGINAL POSITION AFTER ASSEMBLING OR WIRING

There are parts which use the insulation material such as a tube or tape for safety, or which are assembled in the condition that these do not contact with the printed board. The inside wiring is designed not to get closer to the pyrogenic parts and high voltage parts. Therefore, put these parts in the original positions.

### 5. TAKE CARE TO DEAL WITH THE CATHODE-RAY TUBE

In the condition that an explosion-proof cathode-ray tube is set in this equipment, safety is secured against implosion. However, when removing it or serving from backward, it is dangerous to give a shock. Take enough care to deal with it.

### 6. AVOID AN X-RAY

Safety is secured against an X-ray by considering about the cathode-ray tube and the high voltage peripheral circuit, etc.

Therefore, when repairing the high voltage peripheral circuit, use the designated parts and make sure not modify the circuit.

Repairing except indicates causes rising of high voltage, and it emits an X-ray from the cathode-ray tube.

### 7. PERFORM A SAFETY CHECK AFTER SERVICING

Confirm that the screws, parts and wiring which were removed in order to service are put in the original positions, or whether there are the portions which are deteriorated around the serviced places serviced or not. Check the insulation between the antenna terminal or external metal and the AC cord plug blades. And be sure the safety of that.

#### (INSULATION CHECK PROCEDURE)

1. Unplug the plug from the AC outlet.
2. Remove the antenna terminal on TV and turn on the TV.
3. Insulation resistance between the cord plug terminals and the external exposure metal **[Note 2]** should be more than 1M ohm by using the 500V insulation resistance meter **[Note 1]**.
4. If the insulation resistance is less than 1M ohm, the inspection repair should be required.

#### **[Note 1]**

If you have not the 500V insulation resistance meter, use a Tester.

#### **[Note 2]**

External exposure metal: Antenna terminal  
Earphone jack

## HOW TO ORDER PARTS

Please include the following informations when you order parts. (Particularly the CHASSIS CODE.)

#### 1. MODEL NUMBER and CHASSIS CODE

You can find it in the back of your unit.

#### 2. PART NO. and DESCRIPTION

You can find it in your SERVICE MANUAL.

## IMPORTANT

Inferior silicon grease can damage IC's and transistors.

When replacing an IC's or transistors, use only specified silicon grease (YG6260M).

Remove all old silicon before applying new silicon.

# CONTENTS

SERVICING NOTICES ON CHECKING .....	A1-1
HOW TO ORDER PARTS .....	A1-1
IMPORTANT .....	A1-1
CONTENTS .....	A2-1
GENERAL SPECIFICATIONS .....	A3-1~A3-4
INSTRUCTIONS	
1. REMOVAL OF ANODE CAP .....	B1-1
2. REMOVAL AND INSTALLATION OF FLAT PACKAGE IC .....	B2-1, B2-2
SERVICE MODE LIST .....	C-1
CONFIRMATION OF HOURS USED .....	C-1
WHEN REPLACING EEPROM (MEMORY) IC .....	C-2
ELECTRICAL ADJUSTMENTS .....	D-1~D-5
BLOCK DIAGRAM .....	E-1, E-2
PRINTED CIRCUIT BOARDS	
MAIN/CRT .....	F-1~F-4
STEREO/FILTER .....	F-5, F-6
SCHEMATIC DIAGRAMS	
MICON/TUNER/T'TEXT .....	G-1, G-2
VIF/SIF/CHROMA .....	G-3, G-4
21PIN/AV SW .....	G-5, G-6
DEFLECTION/CRT .....	G-7, G-8
POWER .....	G-9, G-10
SOUND AMP .....	G-11, G-12
STEREO .....	G-13, G-14
CHOKE COIL .....	G-15, G-16
WAVEFORMS .....	H-1~H-3
MECHANICAL EXPLODED VIEW .....	I-1
MECHANICAL REPLACEMENT PARTS LIST .....	J1-1
ELECTRICAL REPLACEMENT PARTS LIST .....	J2-1, J2-2

## GENERAL SPECIFICATIONS

G-1	TV System	CRT	CRT Size / Visual Size	28 inch / 660.0mmV	
			CRT Type	Normal	
			Deflection	11Q degree	
			Magnetic Field BV/BH	+0.45G/0.18G	
			Color System	PAL	
			Speaker	2 Speaker	
			Position	Front	
			Size	2.0 x 4.7 Inch	
			Impedance	8 ohm	
			Sound Output	MAX 5.0+5.0 W 10%(Typical) 4.0+4.0 W	
	PAL60Hz	Yes			
G-2	Tuning System	Broadcasting System		CCIR System B/G	
		Tuner and Receive CH	System	1Tuner	
			Destination	CCIR Hyper	
			Tuning System	F-Synth	
			Input Impedance	VHF/UHF 75 ohm	
			CH Coverage	E2 - E4, X - Z+2, S1 - S10, E5 - E12, S11 - S41, E21 - E69	
		Intermediate Frequency	Picture(FP)	38.90MHz	
			Sound(FS)	33.4MHz	
			FP-FS	5.5MHz	
			Preset CH	80	
	Stereo/Dual TV Sound	Yes			
	Tuner Sound Muting	Yes			
G-3	Power	Power Source	AC	230V AC 50Hz	
			DC		
		Power Consumption		at AC	
			Stand by (at AC) Per Year		78 W at AC 230 V 50 Hz 4 W at AC 230 V 50 Hz -- kWh/Year
		Protector	Power Fuse	Yes	
	Safety Circuit	Yes			
	IC Protector(Micro Fuse)	No			
G-4	Regulation	Safety		CE (EN60065:98)	
		Radiation		CE	
		X-Radiation		PTB	
G-5	Temperature	Operation		+5°C ~ +40°C	
		Storage		-20°C ~ +60°C	
G-6	Operating Humidity			Less than 80% RH	
G-7	On Screen Display	Menu		Yes	
		Menu Type		Character	
		Picture		Yes	
			Contrast	Yes	
			Brightness	Yes	
			Colour	Yes	
			Tint	No	
			Sharpness	Yes	
			Audio	Yes	
			Bass	Yes	
			Treble	Yes	
			Balance	Yes	
			BBE On/Off	No	
			Stable Sound On/Off	No	
			CH Tuning	Yes	
			Manual	Yes	
			Auto	Yes	
			CH Allocation	Yes	
			Language	Yes	
			Clock Set	No	
			On/Off Timer Set	No	
			Pin Code Registration	No	
			Nicam Auto Off	No	
			Colour System	No	
			Sound System	No	
			AV2 Output	Yes	
			Output Source	Yes	
			Source	Yes	
			Control Level	Yes	
			Volume	Yes	
	Brightness	Yes			
	Contrast	Yes			
	Colour	Yes			
	Tint (NTSC Only)	No			
	Sharpness	Yes			
	Tuning	Yes			
	Bass	Yes			

## GENERAL SPECIFICATIONS

		Treble	Yes	
		Balance	Yes	
		Back Light		No
		Nicam ST		No
		Stereo	Yes	
		Tone 1/2	Yes	
		Pin Code		No
		AV	Yes	
		Skip	Yes	
		Channel	Yes	
		Hotel Lock		No
		Sleep Timer	Yes	
		Sound Mute	Yes	
<b>G-8</b>	<b>OSD Language</b>		English	French Spanish German Italian
<b>G-9</b>	<b>Clock and Timer</b>	Sleep Timer	Max Time	120 Min
			Step	10 Min
		On/Off Timer	Program(On Timer / Off Timer)	No
		Wake Up Timer		No
		Timer Back-up (at Power Off Mode)	more than	-- Min Sec
<b>G-10</b>	<b>Remote Control</b>	Unit	RC-GE	
		Glow in Dark Remocon	No	
		Format	NEC	
		Custom Code	80-63 h	
		Power Source	Voltage(D.C)	3V
			UM size x pcs	UM-4 x 2 pcs
		Total Keys	31 Keys	
		Keys	Power ( Stand By )	Yes
			1	Yes
			2	Yes
			3	Yes
			4	Yes
			5	Yes
			6	Yes
			7	Yes
			8	Yes
			9	Yes
			0 / AV	Yes
			CH Up	No
			CH Down	No
			Volume Up / +	Yes
			Volume Down / -	Yes
			Quick View	No
			Sleep	Yes
			Info ( CH Call )	Yes
			Normal	No
			Menu	Yes
			Enter	Yes
			Mute	Yes
			Fine Tuning +	No
			Fine Tuning -	No
			Tone 1/2	No
		TTEXT Keys	TEXT / MIX / TV	Yes
			CH Up / Page Up	Yes
			CH Down / Page Down	Yes
			Red	Yes
			Green	Yes
			Yellow / Fine Tuning -	Yes
			Cyan / Fine Tuning +	Yes
			F/T/B(Expand) / Normal	Yes
			Reveal / Skip	Yes
			Display Cancel	Yes
			Reset	No
			Reset / Tone 1/2	Yes
			Hold / Status	Yes
			Sub Page / Quick View	Yes
<b>G-11</b>	<b>Features</b>	Auto Degauss	Yes	
		Auto Shut Off	Yes	
		Canal+	No	
		CATV	No	
		Anti-theft	No	
		Memory(Last CH)	Yes	
		Memory(Last Volume)	Yes	
		BBE	No	
		Auto Search	Yes	
		CH Allocation	Yes	
		Channel Lock	No	

## GENERAL SPECIFICATIONS

		Just Clock Function		No	
		Game Position		No	
		CH Label		No	
		VM Circuit		No	
		Full OSD		No	
		Unitext		No	
		Fastext		No	
		Top Text	Yes		
		Premiere		No	
		Comb Filter		No	
			Lines		
		Auto CH Memory	Yes		
		Stable Sound		No	
		Auto Set Up		No	
		FBT Leak Test Protect		No	
		Power ON Memory	Yes		
		Hotel Lock		No	
G-12	Accessories	Owner's Manual	Language	German	
			w/Guarantee Card	Yes	
		Remote Control Unit		Yes	
		Rod Antenna		No	
			Poles	Pole	
			Terminal	type	
		Loop Antenna		No	
			Terminal	-	
		U/V Mixer		No	
		DC Car Cord (Center+)		No	
		Guarantee Card		No	
		Warning Sheet		No	
		Circuit Diagram		No	
		Antenna Change Plug		No	
		Service Facility List		No	
		Important Safeguard		No	
		Dew/AHC Caution Sheet		No	
		AC Plug Adapter		No	
		Quick Set-up Sheet		No	
		Battery		Yes	
			UM size x pcs	UM-4 x 2 pcs	
			OEM Brand	No	
		AC Cord		No	
AV Cord (2Pin-1Pin)		No			
Registration Card		No			
PTB Sheet		No			
300 ohm to 75 ohm Antenna Adapter		No			
G-13	Interface	Switch	Front	Power (Tact Sw)	No
				System Select	No
				Main Power SW	Yes
				Sub Power	No
				Channel Up	Yes
				Channel Down	Yes
				Volume Up	Yes
				Volume Down	Yes
			Rear	AC/DC	No
				TV/CATV Selector	No
				Degauss	No
				Main Power SW	No
		Indicator		Power	No
				Stand-by	Yes
				On Timer	No
		Terminals	Front	Video Input	RCA
				Audio Input	RCA x 2
				Other Terminal	Headphone
			Rear	Video Input(Rear1)	No
				Video Input(Rear2)	No
				Audio Input(Rear1)	No
				Audio Input(Rear2)	No
				Video Output	No
		Audio Output	No		
		Euro Scart(21Pin)	Yes ( x1 )		
		S-INPUT	Yes ( x1 )		
		Euro Scart(21Pin)	Yes ( x1 )		
		RGB-INPUT	Yes ( x1 )		
		Component input	No		
		Diversity	No		
		Ext Speaker	No		
		DC Jack 12V(Center +)	No		
		VHF/UHF Antenna Input	D Type		

## GENERAL SPECIFICATIONS

		AC Outlet	No
G-14	Set Size	Approx. W x D x H (mm)	711.0 x 485.0 x 546.5
G-15	Weight	Net (Approx.)	30.0kg (--- lbs)
		Gross (Approx.)	33.0Kg (---lbs)
G-16	Carton	Master Carton	No
		Content	--- Sets
		Material	-- /--
		Dimensions W x D x H(mm)	-- x -- x --
		Description of Origin	No
		Gift Box	Yes
		Material	Double/White
		Dimensions W x D x H(mm)	779 x 565 x 641
		Design	As per Buyer's
		Description of Origin	No
		Drop Test	Natural Dropping At 1 Corner / 3 Edges / 6 Surfaces
		Height (cm)	31
		Container Stuffing	180 Sets/40' container
G-17	Cabinet Material	Cabinet Front	PS 94HB
		Cabinet Rear	PS 94HB
		Cover	PS 94V0 NON-DECABROM
		PCB Non-Halogen Demand	No
		Eyelet Demand	No
G-18	Environment	Pb Free Lead-free Solder	No
		Other	No
		Cd Free	No

## DISASSEMBLY INSTRUCTIONS

### 1. REMOVAL OF ANODE CAP

Read the following **NOTED** items before starting work.

- \* After turning the power off there might still be a potential voltage that is very dangerous. When removing the Anode Cap, make sure to discharge the Anode Cap's potential voltage.
- \* Do not use pliers to loosen or tighten the Anode Cap terminal, this may cause the spring to be damaged.

#### REMOVAL

1. Follow the steps as follows to discharge the Anode Cap. (Refer to Fig. 1-1.)  
Connect one end of an Alligator Clip to the metal part of a flat-blade screwdriver and the other end to ground. While holding the plastic part of the insulated Screwdriver, touch the support of the Anode with the tip of the Screwdriver. A cracking noise will be heard as the voltage is discharged.

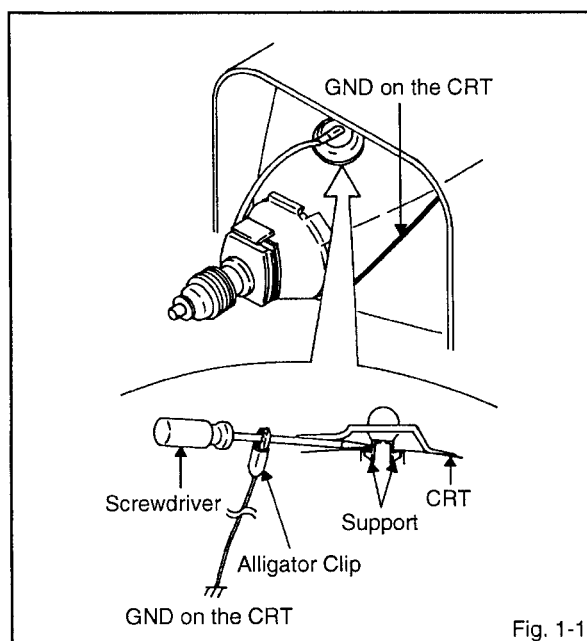

Fig. 1-1

2. Flip up the sides of the Rubber Cap in the direction of the arrow and remove one side of the support. (Refer to Fig. 1-2.)

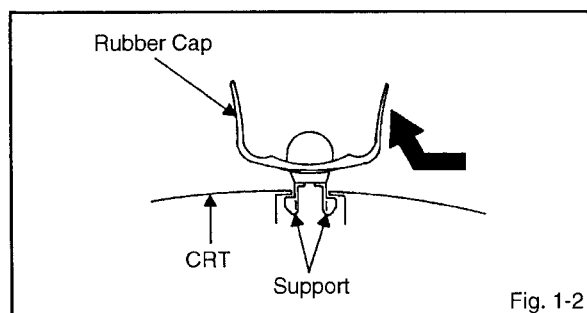

Fig. 1-2

3. After one side is removed, pull in the opposite direction to remove the other.

#### NOTE

Take care not to damage the Rubber Cap.

#### INSTALLATION

1. Clean the spot where the cap was located with a small amount of alcohol. (Refer to Fig. 1-3.)

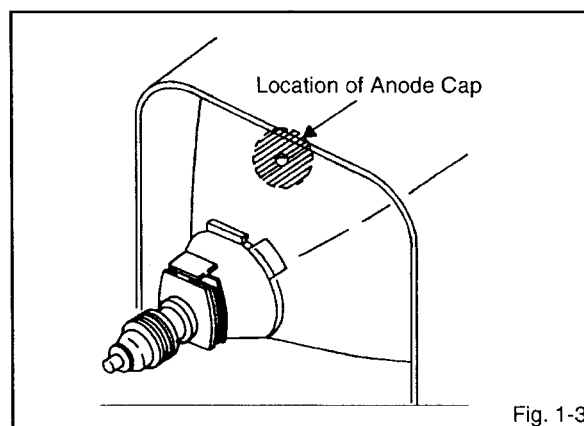

Fig. 1-3

#### NOTE

Confirm that there is no dirt, dust, etc. at the spot where the cap was located.

2. Arrange the wire of the Anode Cap and make sure the wire is not twisted.
3. Turn over the Rubber Cap. (Refer to Fig. 1-4.)

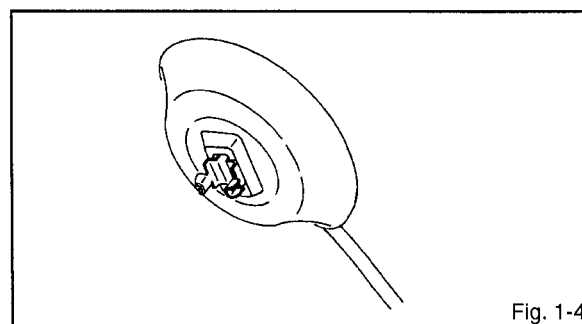

Fig. 1-4

4. Insert one end of the Anode Support into the anode button, then the other as shown in Fig. 1-5.

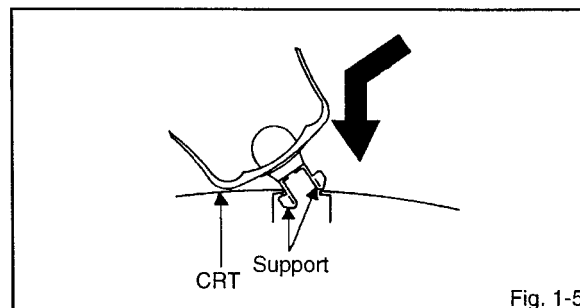

Fig. 1-5

5. Confirm that the Support is securely connected.
6. Put on the Rubber Cap without moving any parts.



## DISASSEMBLY INSTRUCTIONS

### 2. REMOVAL AND INSTALLATION OF FLAT PACKAGE IC

#### REMOVAL

1. Put the Masking Tape (cotton tape) around the Flat Package IC to protect other parts from any damage. (Refer to Fig. 2-1.)

#### NOTE

Masking is carried out on all the parts located within 10 mm distance from IC leads.

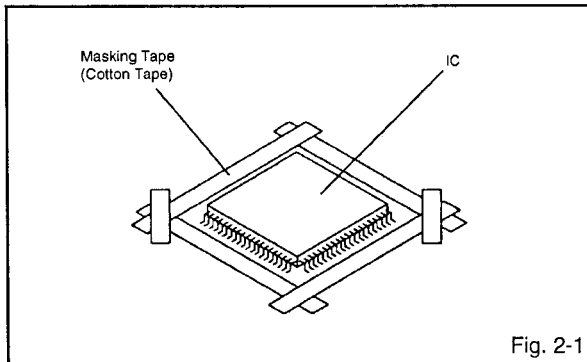

2. Heat the IC leads using a blower type IC desoldering machine. (Refer to Fig. 2-2.)

#### NOTE

Do not add the rotating and the back and forth directions force on the IC, until IC can move back and forth easily after desoldering the IC leads completely.

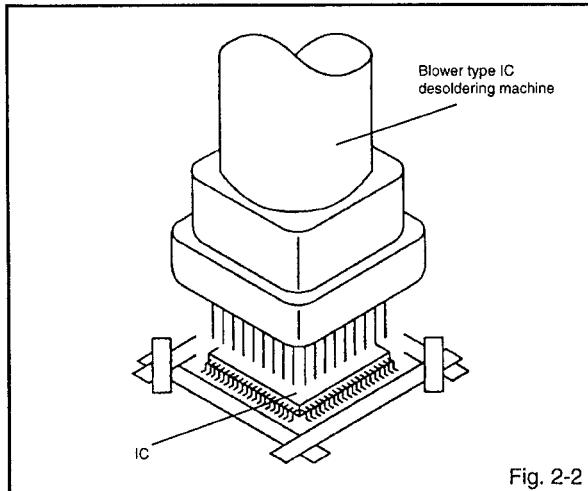

3. When IC starts moving back and forth easily after desoldering completely, pickup the corner of the IC using a tweezers and remove the IC by moving with the IC desoldering machine. (Refer to Fig. 2-3.)

#### NOTE

Some ICs on the PCB are affixed with glue, so be careful not to break or damage the foil of each IC leads or solder lands under the IC when removing it.

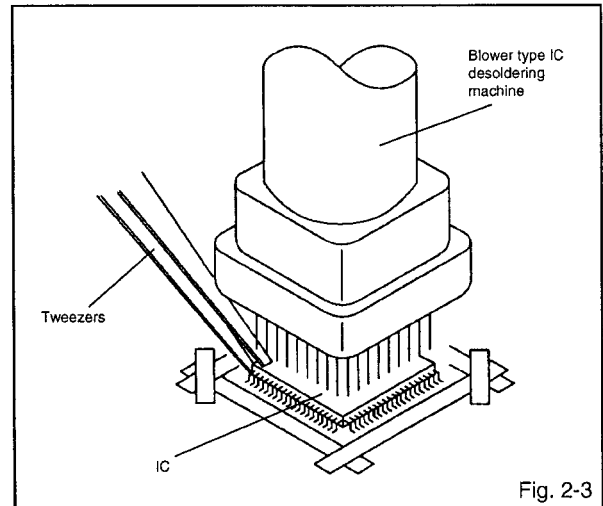

4. Peel off the Masking Tape.
5. Absorb the solder left on the pattern using the Braided Shield Wire. (Refer to Fig. 2-4.)

#### NOTE

Do not move the Braided Shield Wire in the vertical direction towards the IC pattern.

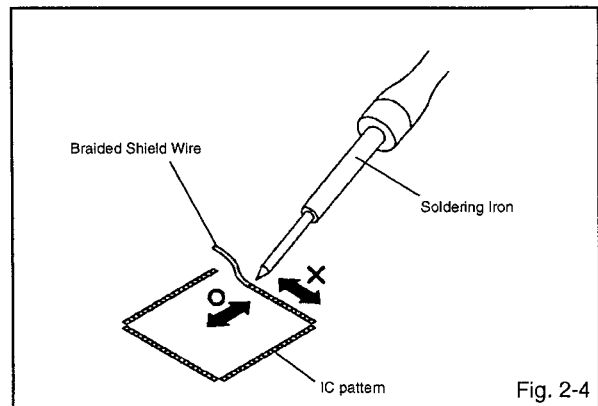

## DISASSEMBLY INSTRUCTIONS

### INSTALLATION

1. Take care of the polarity of new IC and then install the new IC fitting on the printed circuit pattern. Then solder each lead on the diagonal positions of IC temporarily. (Refer to Fig. 2-5.)

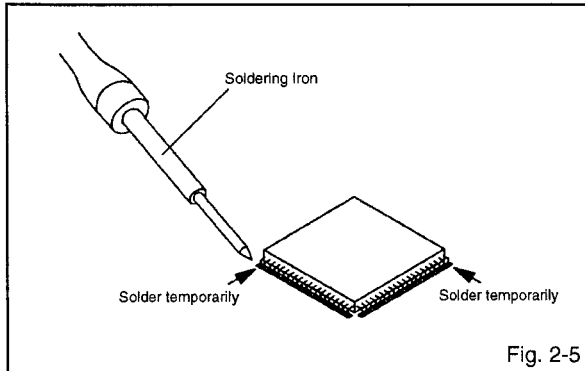

2. Supply the solder from the upper position of IC leads sliding to the lower position of the IC leads. (Refer to Fig. 2-6.)

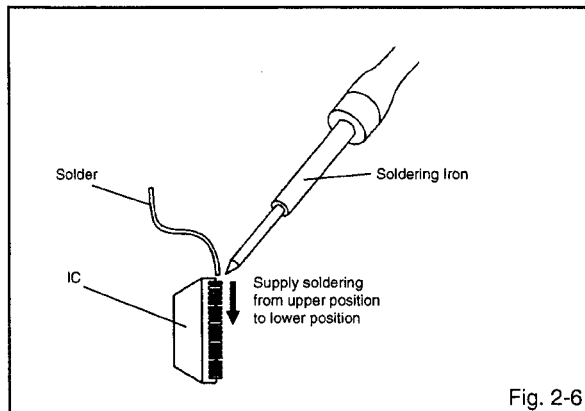

3. Absorb the solder left on the lead using the Braided Shield Wire. (Refer to Fig. 2-7.)

#### NOTE

Do not absorb the solder to excess.

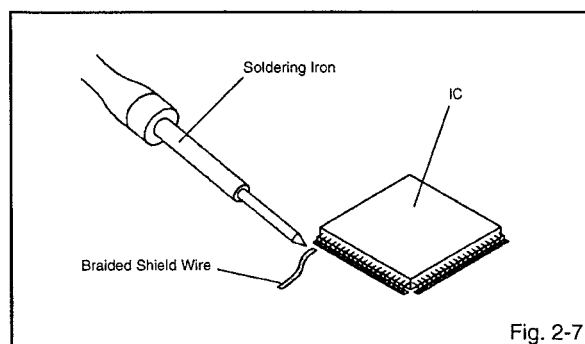

4. When bridge-soldering between terminals and/or the soldering amount are not enough, resolder using a Thin-tip Soldering Iron. (Refer to Fig. 2-8.)

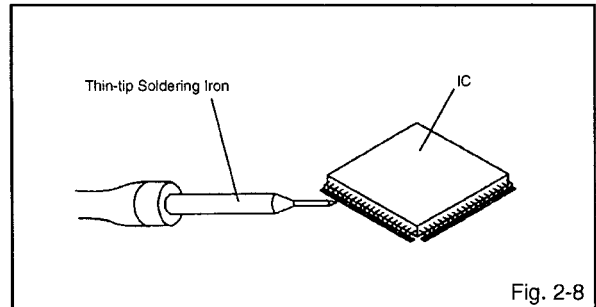

5. Finally, confirm the soldering status on four sides of the IC using a magnifying glass. Confirm that no abnormality is found on the soldering position and installation position of the parts around the IC. If some abnormality is found, correct by resoldering.

#### NOTE

When the IC leads are bent during soldering and/or repairing, do not repair the bending of leads. If the bending of leads are repaired, the pattern may be damaged. So, be always sure to replace the IC in this case.

## SERVICE MODE LIST

This unit provided with the following SERVICE MODES so you can repair, examine and adjust easily.  
To enter the Service Mode, press both set key and remote control key for more than 2 seconds.

Set Key	Remocon Key	Operations
VOL. (-) MIN	0	Reset the user setting items (PICTURE, VOLUME, LANGUAGE) to the initial state for delivery.
VOL. (-) MIN	1	Initialization of the factory. NOTE: Do not use this for the normal servicing. If you set a factory initialization, the memories are reset such as the channel setting, the POWER ON total hours
VOL. (-) MIN	6	POWER ON total hours is displayed on the screen. Refer to the "CONFIRMATION OF HOURS USED".  Can be checked of the INITIAL DATA of MEMORY IC. Refer to the "WHEN REPLACING EEPROM (MEMORY) IC".
VOL. (-) MIN	8	Writing of EEPROM initial data. NOTE: Do not use this for the normal servicing.
VOL. (-) MIN	9	Display of the Adjustment MENU on the screen. Refer to the "ELECTRICAL ADJUSTMENT" (On-Screen Display Adjustment).

## CONFIRMATION OF HOURS USED

POWER ON total hours can be checked on the screen. Total hours are displayed in 16 system of notation.

1. Set the VOLUME to minimum.
2. Press both VOL. DOWN button on the set and Channel button **(6)** on the remote control.
3. After the confirmation of using hours, turn off the power.

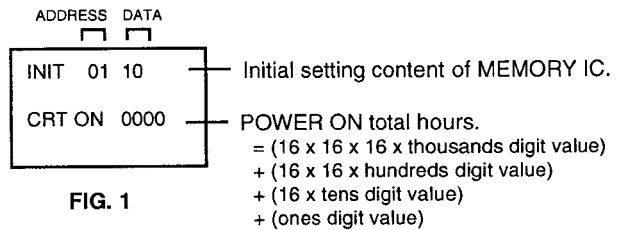

## WHEN REPLACING EEPROM (MEMORY) IC

If a service repair is undertaken where it has been required to change the MEMORY IC, the following steps should be taken to ensure correct data settings while making reference to TABLE 1.

INI	+0	+1	+2	+3	+4	+5	+6	+7	+8	+9	+A	+B	+C	+D	+E	+F
00	--	10	38	29	24	30	80	41	01	45	00	01	03	00	06	72
10	20	00	80	80	80	04	00									

**Table 1**

1. Enter DATA SET mode by setting VOLUME to minimum.
2. While holding down VOLUME button on front cabinet, press key 6 on remote control for more than 2 seconds.

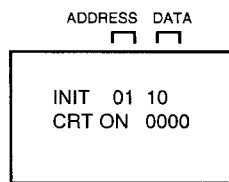

**Fig. 1**

3. ADDRESS is now selected and should "blink". Using the VOL. +/- button on the remote, step through the ADDRESS until required ADDRESS to be changed is reached.
4. Press ENTER to select DATA. When DATA is selected, it will "blink".
5. Again, step through the DATA using VOL. +/- button until required DATA value has been selected.
6. Pressing ENTER will take you back to ADDRESS for further selection if necessary.
7. Repeat steps 3 to 6 until all data has been checked.
8. When satisfied correct DATA has been entered, turn POWER off (return to STANDBY MODE) to finish DATA input.

**After the data input, set to the initializing of shipping.**

9. Turn POWER on.
10. While holding down VOLUME button on front cabinet, press key 1 on remote control for more than 2 seconds.
11. After the finishing of the initializing of shipping, the unit will turn off automatically.

The unit will now have the correct DATA for the new MEMORY IC.

# ELECTRICAL ADJUSTMENTS

## 1. BEFORE MAKING ELECTRICAL ADJUSTMENTS

Read and perform these adjustments when repairing the circuits or replacing electrical parts or PCB assemblies.

### CAUTION

- Use an isolation transformer when performing any service on this chassis.
- Before removing the anode cap, discharge electricity because it contains high voltage.
- When removing a PCB or related component, after unfastening or changing a wire, be sure to put the wire back in its original position.
- When you exchange IC and Transistor for a heat sink, apply the silicon grease (**YG6260M**) on the contact section of the heat sink. Before applying new silicon grease, remove all the old silicon grease. (Old grease may cause damages to the IC and Transistor).

Prepare the following measurement tools for electrical adjustments.

1. Oscilloscope
2. Digital Voltmeter
3. Pattern Generator

### On-Screen Display Adjustment

1. In the condition of NO indication on the screen. Press the VOL. DOWN button on the set and the Channel button (9) on the remote control for more than 2 seconds to appear the adjustment mode on the screen as shown in Fig. 1-1.

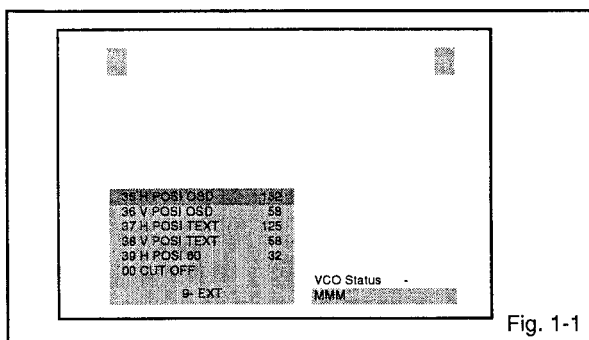

Fig. 1-1

2. Use the Channel UP/DOWN button or Channel button (0-9) on the remote control to select the options shown in Fig. 1-2.
3. Press the MENU button on the remote control to end the adjustments.

NO.	FUNCTION	NO.	FUNCTION
00	CUT OFF	25	COLOR CENT
01	RF AGC	26	COLOR MAX
02	AGC GAIN	27	COLOR MIN
03	R DRIVE	28	M R CUT OFF
04	R CUT OFF	29	M G CUT OFF
05	G DRIVE	30	M B CUT OFF
06	G CUT OFF	31	CVBS OUT
07	B DRIVE	32	APR THR
08	H POSI 50	33	BELL FILTER
09	V POSI 50	34	BANDPASS
10	V POSI 60	35	H POSI OSD
11	V SIZE 50	36	V POSI OSD
12	V SIZE 60	37	H POSI TXT
13	VCO COARSE	38	V POSI TXT
14	VCO FINE	39	H POSI 60
15	VCO COARSE L1	40	V POSI 50
16	VCO LINE L1	41	V POSI 60
17	BRIGHT CENT	42	V SIZE 50
18	BRIGHT MAX	43	V SIZE 60
19	BRIGHT MIN	44	SCORR
21	SHARP	45	C CORR
22	CONT CENT	46	H SIZE
23	CONT MAX	47	PIN CUSH
24	CONT MIN	48	E/W SHAPE
		49	TRAPEZ

Fig. 1-2

## 2. BASIC ADJUSTMENTS

### 2-1: AGC VOLTAGE

1. Place the set with Aging Test for more than 15 minutes.
2. Receive the VHF (HIGHT) (63±1dB).
3. Connect the digital voltmeter between the pin 5 and pin 1 (GND) of CP101.
4. Activate the adjustment mode display of Fig. 1-1 and press the channel button (01) on the remote control to select "RF AGC".
5. Press the VOL. UP/DOWN button on the remote control until the digital voltmeter is 2.40 ± 0.05V.

### 2-2: CUT OFF

1. Place the set with Aging Test for more than 15 minutes.
2. Activate the adjustment mode display of Fig. 1-1 and press the channel button (00) on the remote control to select "CUT OFF".
3. Adjust the Screen Volume until a dim raster is obtained.

### 2-3: WHITE BALANCE

**NOTE:** Adjust after performing CUT OFF adjustment.

1. Place the set with Aging Test for more than 15 minutes.
2. Receive the gray scale pattern from the Pattern Generator.
3. Using the remote control, set the brightness and contrast to normal position.
4. Activate the adjustment mode display of Fig. 1-1 and press the channel button (03) on the remote control to select "R DRIVE".
5. Press the Channel UP/DOWN button on the remote control to select the "R DRIVE", "G DRIVE", "M R CUTOFF" or "M G CUTOFF".
6. Adjust the VOL. UP/DOWN button on the remote control to whiten the R DRIVE, G DRIVE, M R CUT OFF, and M G CUT OFF at each step tone sections equally.
7. Perform the above adjustments 5 and 6 until the white color is looked like a white.

## ELECTRICAL ADJUSTMENTS

### 2-4: FOCUS

1. Receive the monoscope pattern.
2. Turn the Focus Volume fully counterclockwise once.
3. Adjust the **Focus Volume** until picture is distinct.

### 2-5: CONSTANT VOLTAGE

1. Place the set with Aging Test for more than 5 minutes.
2. Using the remote control, set the brightness and contrast to normal position.
3. Connect the digital voltmeter to **TP501**.
4. Set condition is **AV MODE** without signal.
5. Adjust the **VR501** until the digital voltmeter is  $135 \pm 0.5V$ .

### 2-6: HORIZONTAL POSITION

1. Receive the monoscope pattern. (RF Input)
2. Place the set with Aging Test for more than 15 minutes.
3. Using the remote control, set the brightness and contrast to normal position.
4. Activate the adjustment mode display of **Fig. 1-1** and press the channel button (**08**) on the remote control to select "H POSI(50)".
5. Press the VOL. UP/DOWN button on the remote control until the SHIFT quantity of the OVER SCAN on right and left becomes minimum.
6. Receive the monoscope pattern of NTSC. (Audio Video Input)
7. Using the remote control, set the brightness and contrast to normal position.
8. Activate the adjustment mode display of **Fig. 1-1** and press the channel button (**39**) on the remote control to select "H POSI(60)".
9. Press the VOL. UP/DOWN button on the remote control until the SHIFT quantity of the OVER SCAN on right and left becomes minimum.

### 2-7: VERTICAL POSITION, VERTICAL LINEALITY

1. Receive the monoscope pattern. (RF Input)
2. Place the set with Aging Test for more than 15 minutes.
3. Using the remote control, set the brightness and contrast to normal position.
4. Activate the adjustment mode display of **Fig. 1-1** and press the channel button (**40**) on the remote control to select "V POSI(50)".
5. Press the VOL. UP/DOWN button on the remote control until the SHIFT quantity of the OVER SCAN on right and left becomes minimum.
6. Activate the adjustment mode display of **Fig. 1-1** and press the channel button (**45**) on the remote control to select "C CORRP".
7. Press the VOL. UP/DOWN button on the remote control until the position of CRT CENTER line of screen and CRT CENTER marker to same.
8. Receive the monoscope pattern of NTSC. (Audio Video Input)
9. Using the remote control, set the brightness and contrast to normal position.
10. Activate the adjustment mode display of **Fig. 1-1** and press the channel button (**41**) on the remote control to select "V POSI(60)".
11. Press the VOL. UP/DOWN button on the remote control until the Shift quantity of the OVER SCAN on right and left becomes minimum.

### 2-8: VERTICAL SIZE

1. Receive the monoscope pattern. (RF Input)
2. Place the set with Aging Test for more than 15 minutes.
3. Using the remote control, set the brightness and contrast to normal position.
4. Activate the adjustment mode display of **Fig. 1-1** and press the channel button (**42**) on the remote control to select "V SIZE(50)".
5. Press the VOL. UP/DOWN button on the remote control until the SHIFT quantity of the OVER SCAN on upside and downside becomes  $8 \pm 2\%$ .
6. Receive the monoscope pattern of NTSC. Using the remote control, set the brightness and contrast to normal position.
7. Activate the adjustment mode display of **Fig. 1-1** and press the channel button (**43**) on the remote control to select "V SIZE(60)".
8. Press the VOL. UP/DOWN button on the remote control until the SHIFT quantity of the OVER SCAN on upside and downside becomes  $10 \pm 2\%$ .

### 2-9: BRIGHT CENT

1. Receive the black pattern\*. (RF Input)
2. Using the remote control, set the brightness and contrast to normal position.
3. Place the set with Aging Test for more than 15 minutes.
4. Activate the adjustment mode display of **Fig. 1-1** and press the channel button (**17**) on the remote control to select "BRIGHT CENT".
5. Press the VOL. UP/DOWN button on the remote control until the screen begin to shine.
6. Receive the black pattern\*. (Audio Video Input)
7. Set to the AV mode. Then perform the above adjustments 2~5.

\*The Black Pattern means the whole black raster signal. Select the "RASTER" of the pattern generator, set to the OFF position for each R, G and B.

### 2-10: CONTRAST CENT

1. Receive the color bar pattern. (RF Input)
2. Using the remote control, set the brightness and contrast to normal position.
3. Activate the adjustment mode display of **Fig. 1-1** and press the channel button (**22**) on the remote control to select "CONT CENT".
4. Press the VOL. UP/DOWN button on the remote control until the contrast step No. becomes "44".
5. Receive a broadcast and check if the picture is normal.
6. Receive the color bar pattern. (Audio Video)
7. Press the TV/VIDEO button on the remote control to set to the AV mode. Then perform the above adjustments 2~5.

## ELECTRICAL ADJUSTMENTS

### 2-11: COLOR CENT

1. Receive the color bar pattern. (RF Input)
2. Place the set with Aging Test for more than 15 minutes.
3. Connect the oscilloscope to **TP801**.
4. Using the remote control, set the brightness, contrast and color to normal position.
5. Activate the adjustment mode display of **Fig. 1-1** and press the channel button **(25)** on the remote control to select "COLOR CENT".
6. Adjust the VOLTS RANGE VARIABLE knob of the oscilloscope until the range between white 100% and 0% is set to 5 scales on the screen of the oscilloscope.
7. Press the VOL. UP/DOWN button on the remote control until the red color level is adjusted to  $90 \pm 10\%$  for the white level. (**Refer to Fig. 2-1**)
8. Receive the color bar pattern. (Audio Video Input)
9. Set to the AV mode. Then perform the above adjustments 2-6.

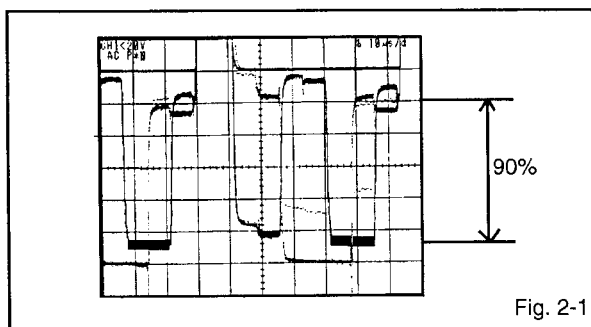

### 2-12: VCO COARSE/VCO FINE

1. Place the set with Aging Test for more than 10 minutes.
2. Connect the oscillator (38.9MHz) to **TP001**.
3. Activate the adjustment mode display of **Fig. 1-1** and press the channel button **(13)** on the remote control to select "VCO COARSE".
4. Press the VOL. UP/DOWN button on the remote control until the "OK" appear on the screen. If the "OK" is not displayed, select the "-" side on the changed from "+" to "-".
5. Press the CH UP button once to set to "VCO FINE" mode.
6. Press the VOL. UP/DOWN button on the remote control to select the 5 step down point from the upper limit on the "OK".  
(Example: In case of the "OK" point 30-41, select 37.)

### 2-13: PIN CUSH/TRAPEZ

1. Receive the crosshatch signal from the Pattern Generator.
2. Place the set with Aging Test for more than 15 minutes.
3. Using the remote control, set the brightness and contrast to normal position.
4. Activate the adjustment mode display of **Fig. 1-1** and press the channel button **(49)** on the remote control to select "TRAPEZ".
5. Press the VOL. UP/DOWN button on the remote control until the both vertical lines of the screen become parallel.
6. Activate the adjustment mode display of **Fig. 1-1** and press the channel button **(47)** on the remote control to select "PIN CUSH".
7. Press the VOL. UP/DOWN button on the remote control until the right and left vertical lines are straight.

### 2-14: Confirmation of Fixed Value (Step No.)

Please check if the fixed values of the each adjustment items are set correctly referring below.

NO.	FUNCTION	RF	AV
02	AGC GAIN	00	---
04	R CUTOFF	00	---
06	G CUTOFF	00	---
07	B DRIVE	45	---
18	BRIGHT MAX	60	60
19	BRIGHT MIN	15	15
21	SHARP	03	03
23	CONT MAX	63	63
24	CONT MIN	05	05
26	COLOR MAX	50	50
27	COLOR MIN	10	10
30	M B CUTOFF	127	---
31	CVBS OUT	31	---
32	APR THR	00	---
33	BELL FILTER	00	---
34	BANDPASS	00	00
35	H POSI OSD	132	---
36	V POSI OSD	58	---
37	H POSI TXT	125	---
38	V POSI TXT	58	---
44	SCORR	04	---
48	E/W SHAPE	00	---

# ELECTRICAL ADJUSTMENTS

## 3. PURITY AND CONVERGENCE ADJUSTMENTS

### NOTE

1. Turn the unit on and let it warm up for at least 30 minutes before performing the following adjustments.
2. Place the CRT surface facing east or west to reduce the terrestrial magnetism.
3. Turn ON the unit and demagnetize with a Degauss Coil.

### 3-1: STATIC CONVERGENCE (ROUGH ADJUSTMENT)

1. Tighten the screw for the magnet. Refer to the adjusted CRT for the position. **(Refer to Fig. 3-1)**  
If the deflection yoke and magnet are in one body, untighten the screw for the body.
2. Receive the green raster pattern from the color bar generator.
3. Slide the deflection yoke until it touches the funnel side of the CRT.
4. Adjust center of screen to green, with red and blue on the sides, using the pair of purity magnets.
5. Switch the color bar generator from the green raster pattern to the crosshatch pattern.
6. Combine red and blue of the 3 color crosshatch pattern on the center of the screen by adjusting the pair of 4 pole magnets.
7. Combine red/blue (magenta) and green by adjusting the pair of 6 pole magnets.
8. Adjust the crosshatch pattern to change to white by repeating steps 6 and 7.

### 3-2: PURITY

#### NOTE

Adjust after performing adjustments in section 3-1.

1. Receive the green raster pattern from color bar generator.
2. Adjust the pair of purity magnets to center the color on the screen.  
Adjust the pair of purity magnets so the color at the ends are equally wide.
3. Move the deflection yoke backward (to neck side) slowly, and stop it at the position when the whole screen is green.
4. Confirm red and blue colors.
5. Adjust the slant of the deflection yoke while watching the screen, then tighten the fixing screw.

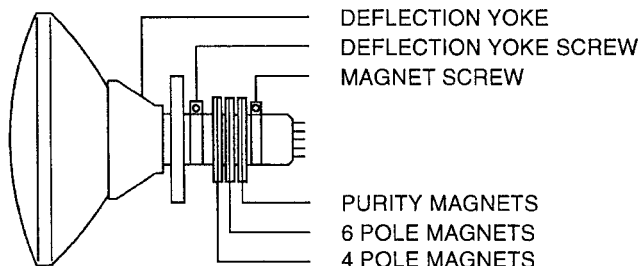

Fig. 3-1

### 3-3: STATIC CONVERGENCE

#### NOTE

Adjust after performing adjustments in section 3-2.

1. Receive the crosshatch pattern from the color bar generator.
2. Combine red and blue of the 3 color crosshatch pattern on the center of the screen by adjusting the pair of 4 pole magnets.
3. Combine red/blue (magenta) and green by adjusting the pair of 6 pole magnets.

### 3-4: DYNAMIC CONVERGENCE

#### NOTE

Adjust after performing adjustments in section 3-3.

1. Adjust the differences around the screen by moving the deflection yoke upward/downward and right/left. **(Refer to Fig. 3-2-a)**
2. Insert three wedges between the deflection yoke and CRT funnel to fix the deflection yoke. **(Refer to Fig. 3-2-b)**

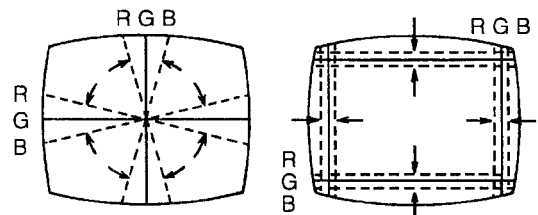

UPWARD/DOWNWARD SLANT    RIGHT/LEFT SLANT

Fig. 3-2-a

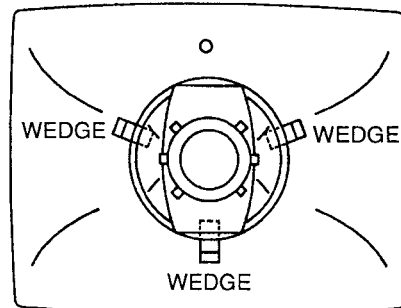

WEDGE POSITION

Fig. 3-2-b



# ELECTRICAL ADJUSTMENTS

## 4. ELECTRICAL ADJUSTMENT PARTS LOCATION GUIDE (WIRING CONNECTION)

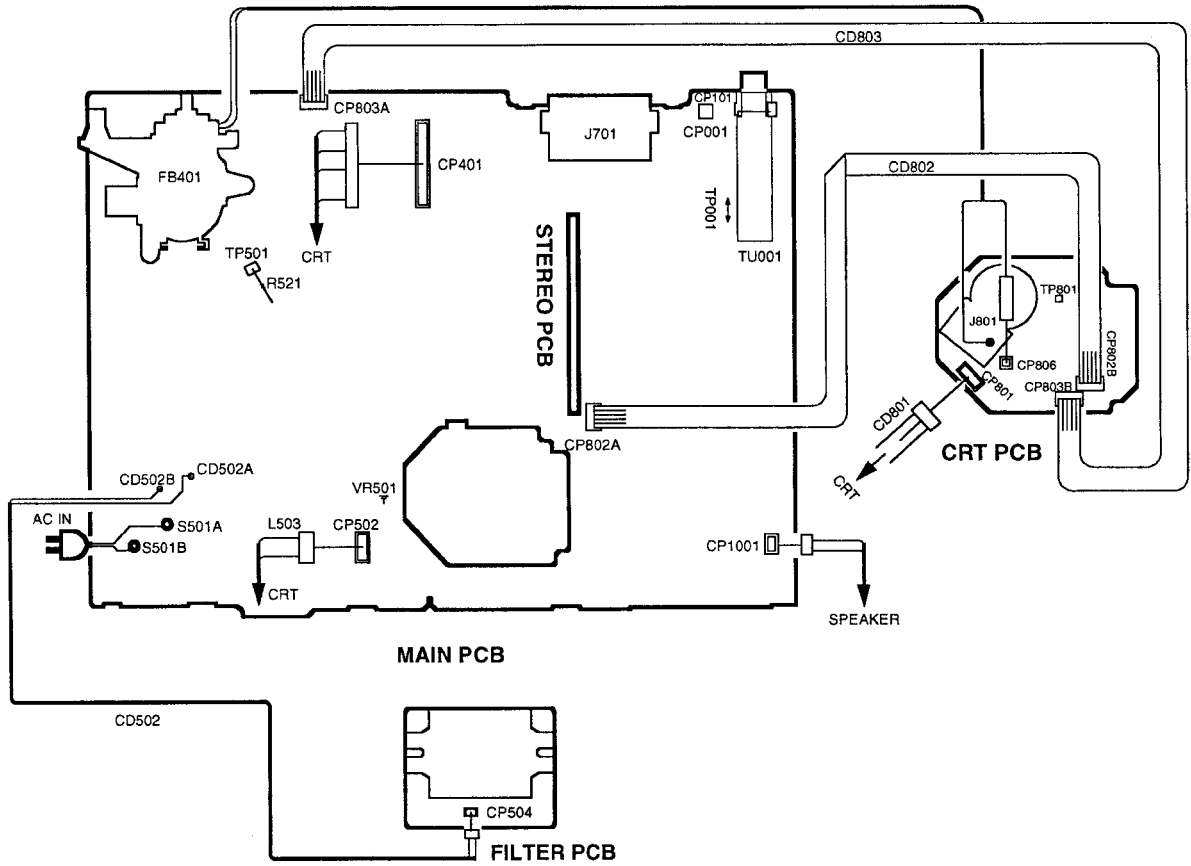

# BLOCK DIAGRAM

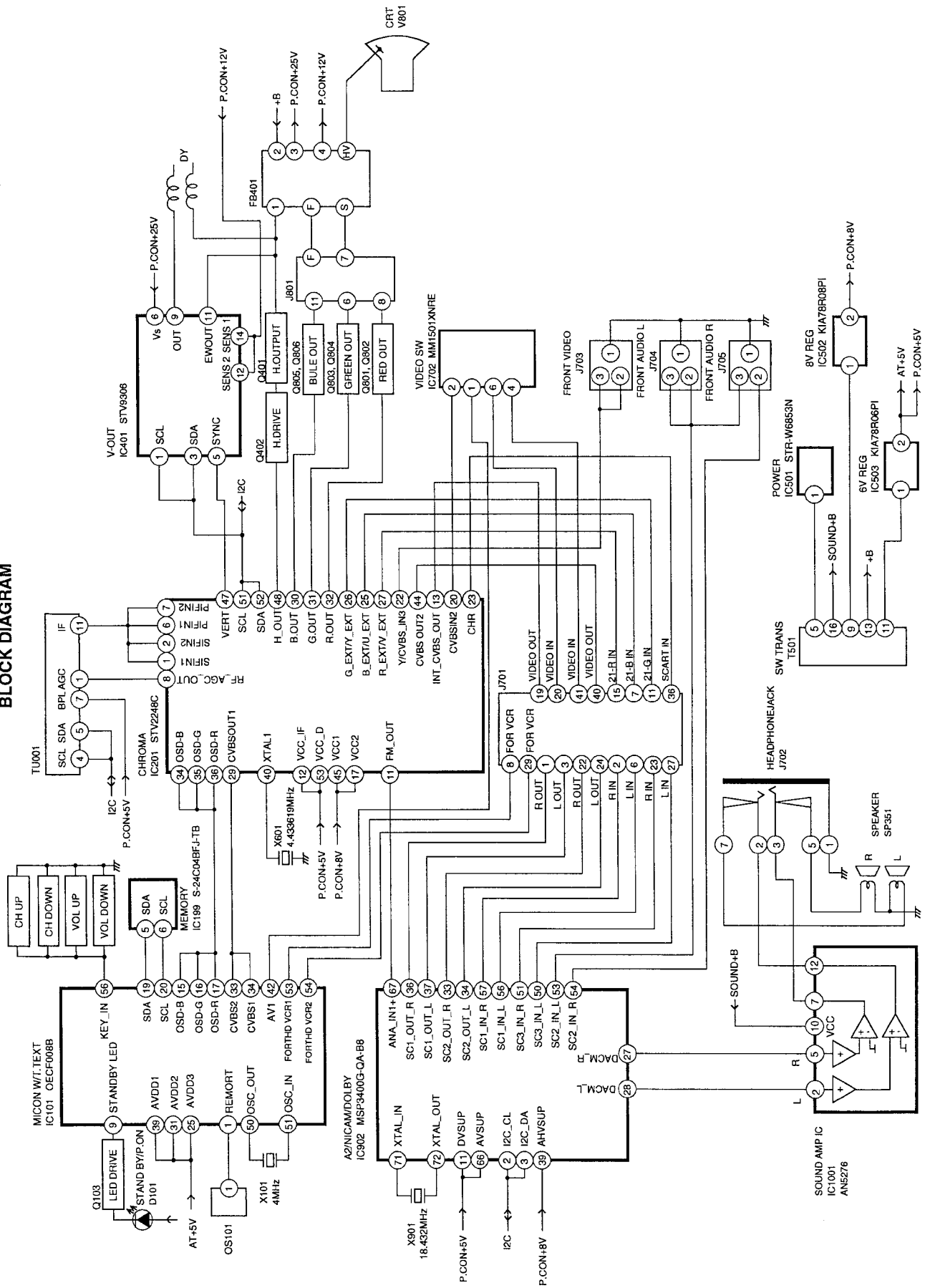

# PRINTED CIRCUIT BOARDS

## STEREO (INSERTED PARTS) SOLDER SIDE

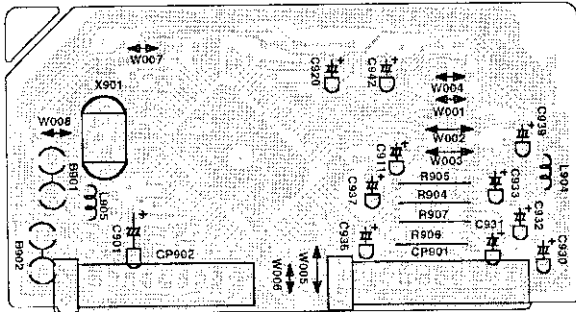

## STEREO (CHIP MOUNTED PARTS) SOLDER SIDE

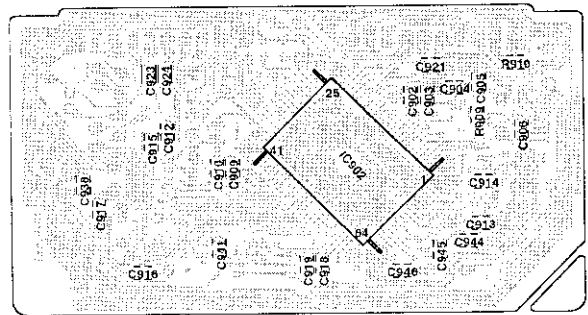

## FILTER SOLDER SIDE

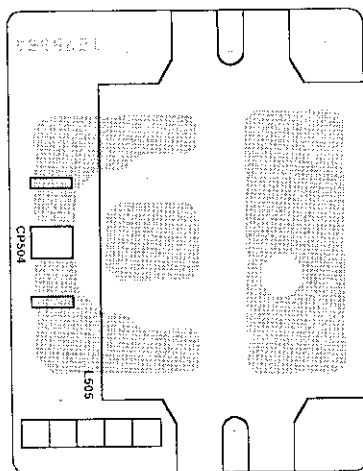



PRINTED CIRCUIT BOARDS  
MAIN/CRT (CHIP MOUNTED PARTS)  
SOLDER SIDE

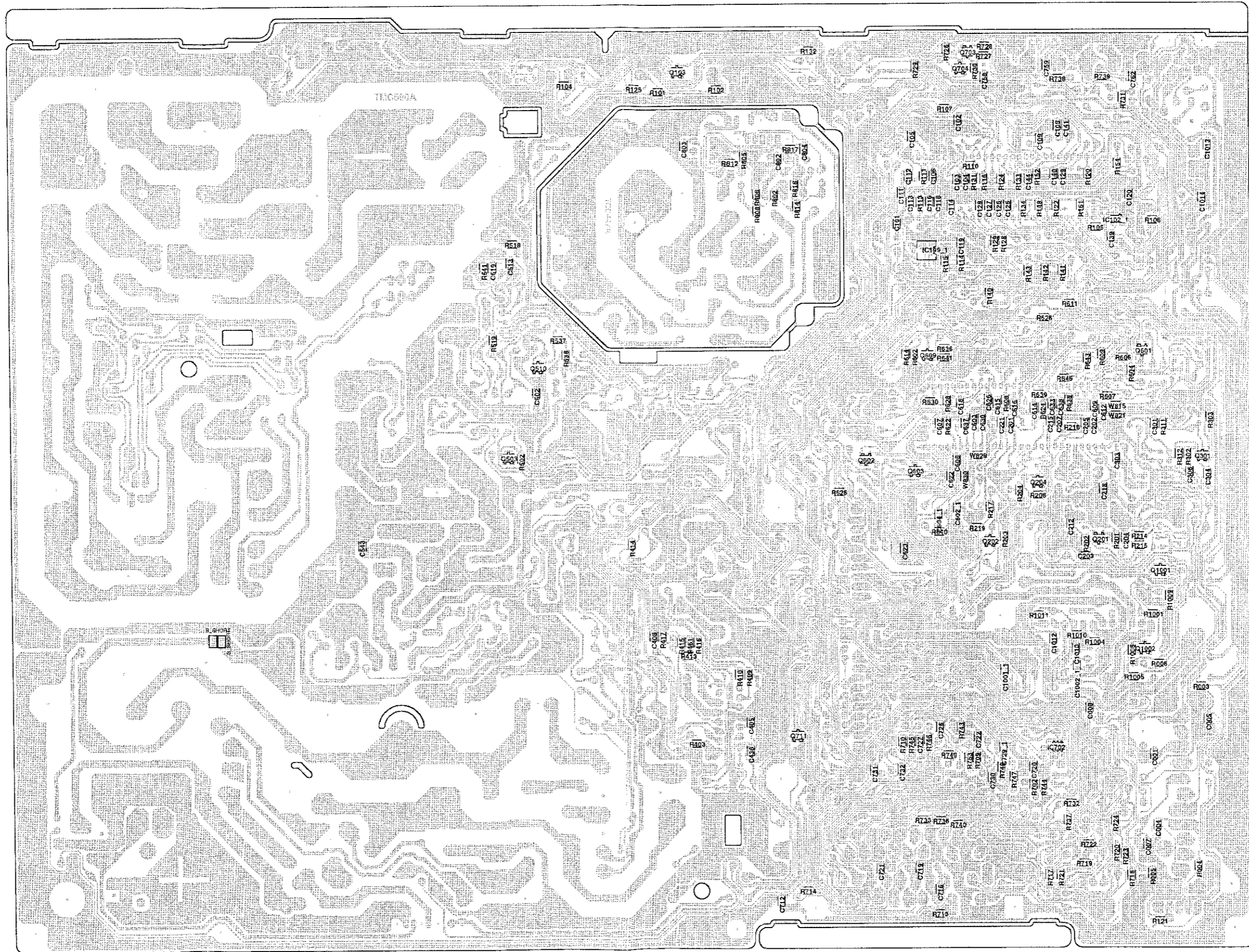

# MICON/TUNER/T' TEXT SCHEMATIC DIAGRAM (TV MT PCB)

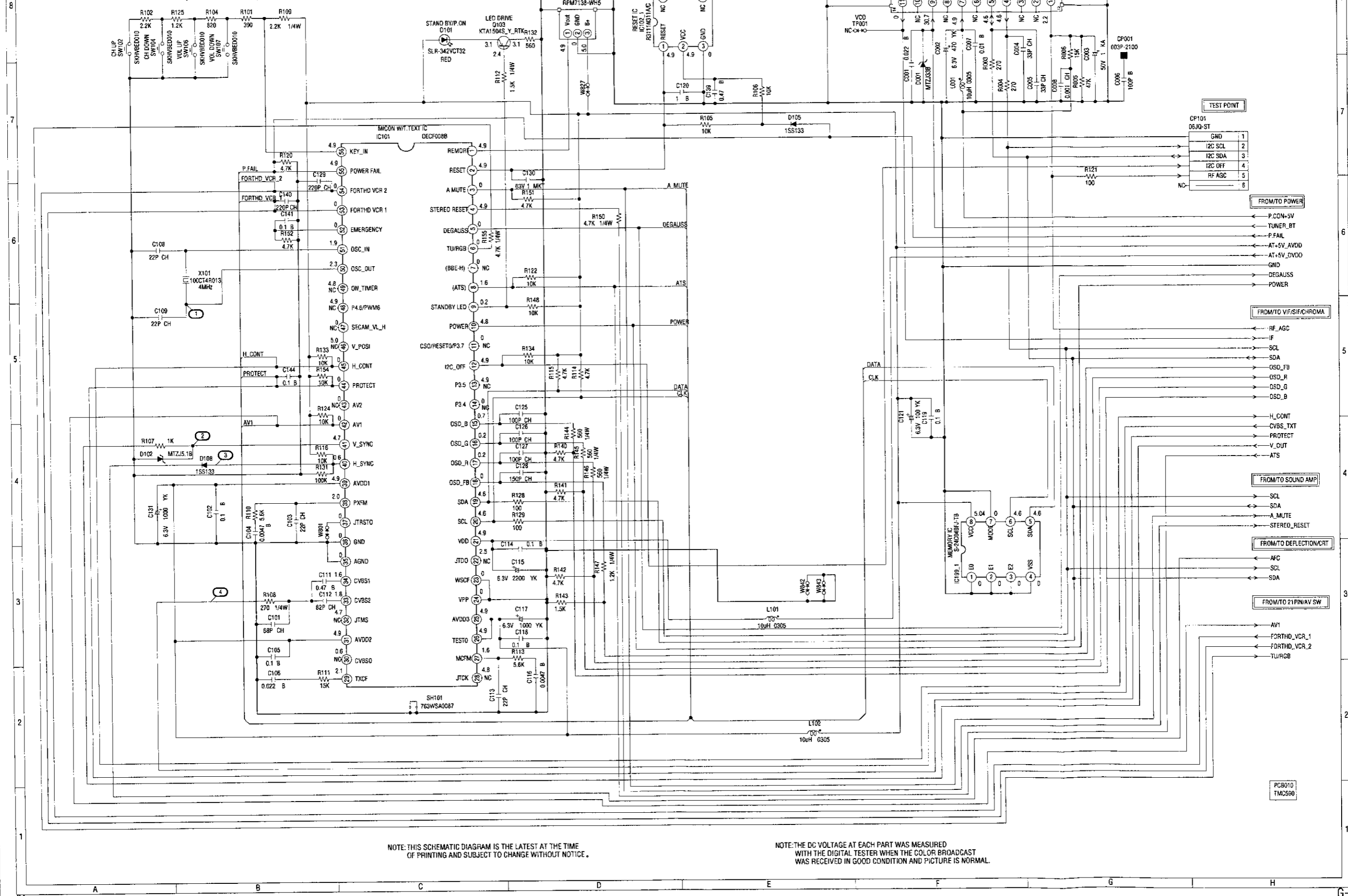

**TEST POINT**

CP101	06JQ-ST
GND	1
I2C SCL	2
I2C SDA	3
I2C OFF	4
RF AGC	5
NC	6

**FROM/TO POWER**

- P.CON-5V
- TUNER\_BT
- P.FAIL
- AT-5V\_AVDD
- AT-5V\_DVDD
- GND
- DEGAUSS
- POWER

**FROM/TO VIF/SIF/CHROMA**

- RF\_AGC
- IF
- SCL
- SDA
- OSD\_FB
- OSD\_R
- OSD\_G
- OSD\_B
- H\_CONT
- CVBS\_TXT
- PROTECT
- V\_CUT
- ATS

**FROM/TO SOUND AMP**

- SCL
- SDA
- A\_MUTE
- STEREO\_RESET

**FROM/TO DEFLECTION CRT**

- AFC
- SCL
- SDA

**FROM/TO 21PIN V SW**

- AV1
- FDRTHD\_VCR\_1
- FDRTHD\_VCR\_2
- TURGB

PCB010  
TMC590

NOTE: THIS SCHEMATIC DIAGRAM IS THE LATEST AT THE TIME OF PRINTING AND SUBJECT TO CHANGE WITHOUT NOTICE.

NOTE: THE DC VOLTAGE AT EACH PART WAS MEASURED WITH THE DIGITAL TESTER WHEN THE COLOR BROADCAST WAS RECEIVED IN GOOD CONDITION AND PICTURE IS NORMAL.

# VIF/SIF/CHROMA SCHEMATIC DIAGRAM (TV MT PCB)

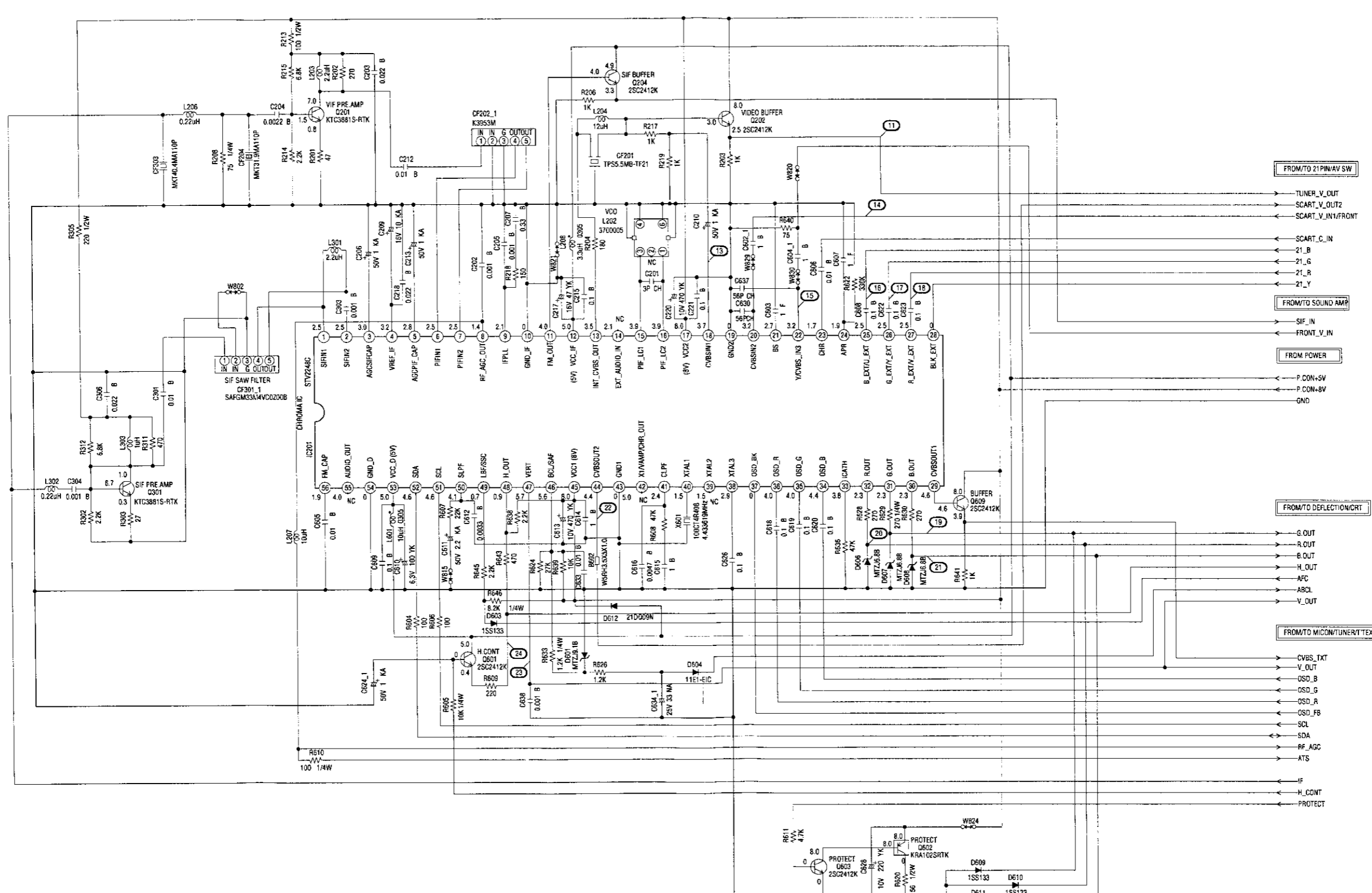

- FROM/TO 21PIN/AV SW
  - TUNER\_V\_OUT
  - SCART\_V\_OUT2
  - SCART\_V\_IN1/FRONT
  - SCART\_C\_IN
  - 21\_B
  - 21\_G
  - 21\_R
  - 21\_Y
- FROM/TO SOUND AMP
  - SIF\_IN
  - FRONT\_V\_IN
- FROM POWER
  - F.CON+5V
  - F.CON+8V
  - GND
- FROM/TO DEFLECTION/CRT
  - G\_OUT
  - R\_OUT
  - B\_OUT
  - H\_OUT
  - AFC
  - ABCL
  - V\_OUT
- FROM/TO MICOM/TUNER/TEXT
  - CVBS\_TXT
  - V\_OUT
  - OSD\_B
  - OSD\_G
  - OSD\_R
  - OSD\_FB
  - SCL
  - SDA
  - RF\_AGC
  - ATS
  - IF
  - H\_CONT
  - PROTECT

NOTE: THIS SCHEMATIC DIAGRAM IS THE LATEST AT THE TIME OF PRINTING AND SUBJECT TO CHANGE WITHOUT NOTICE.

NOTE: THE DC VOLTAGE AT EACH PART WAS MEASURED WITH THE DIGITAL TESTER WHEN THE COLOR BROADCAST WAS RECEIVED IN GOOD CONDITION AND PICTURE IS NORMAL.

CAUTION: DIGITAL TRANSISTOR

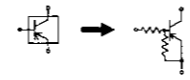

PC8010  
TMC598

# 21PIN/AV SW SCHEMATIC DIAGRAM (TV MT PCB)

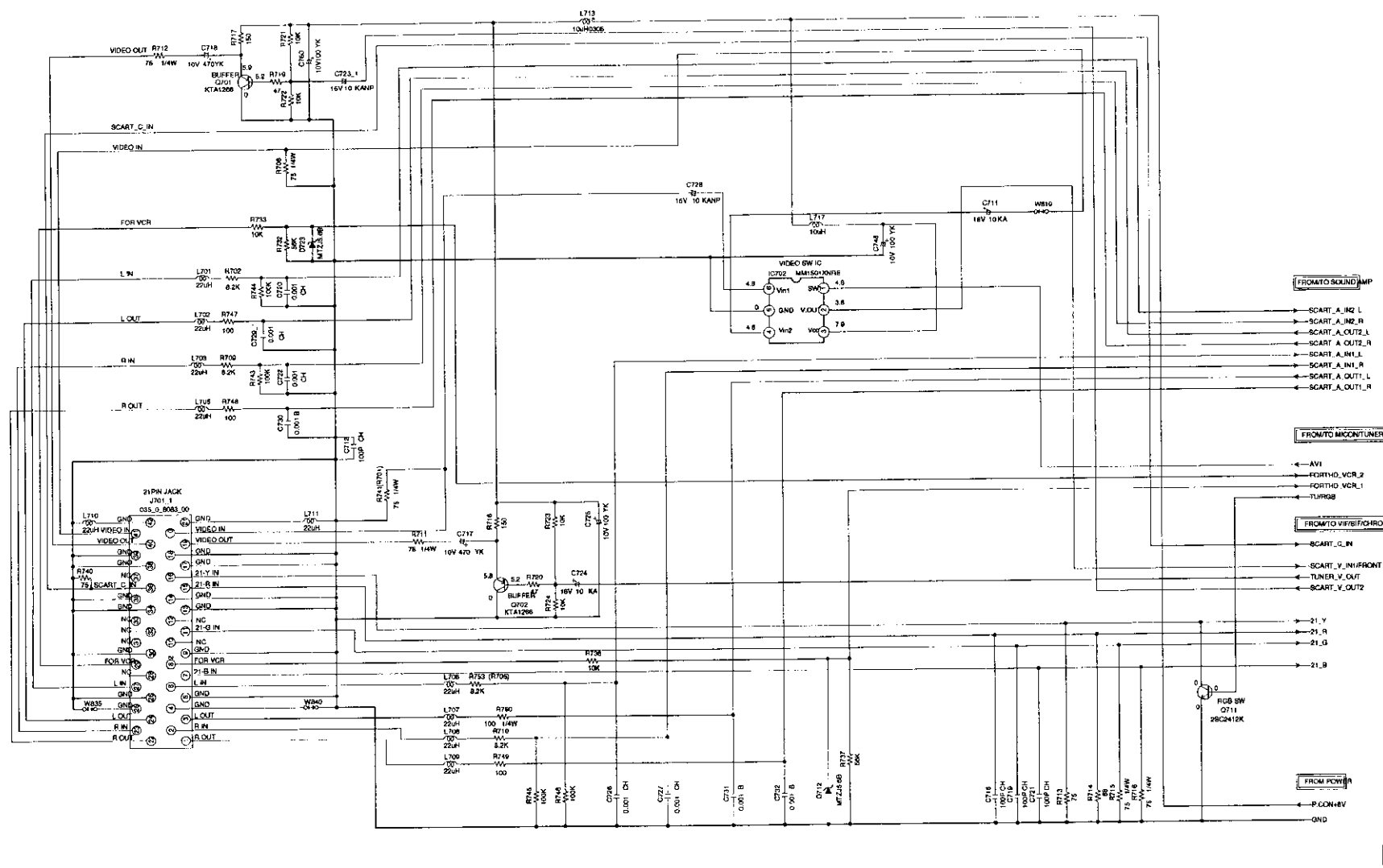

FROM TO SOUND AMP  
 SCART\_A\_IN2\_L  
 SCART\_A\_IN2\_R  
 SCART\_A\_OUT2\_L  
 SCART\_A\_OUT2\_R  
 SCART\_A\_IN1\_L  
 SCART\_A\_IN1\_R  
 SCART\_A\_OUT1\_L  
 SCART\_A\_OUT1\_R

FROM TO MICONTUNER UNIT  
 AVI  
 FORTH\_VCR\_2  
 FORTH\_VCR\_1  
 TUNRGB

FROM TO VHS/VIDEO  
 SCART\_G\_IN  
 SCART\_V\_IN/FRONT  
 TUNER\_V\_OUT  
 SCART\_V\_OUT2

21\_Y  
 21\_R  
 21\_G  
 21\_B

FROM PCWR  
 P\_CON+5V  
 GND

PC800  
 1M4550

NOTE: THIS SCHEMATIC DIAGRAM IS THE LATEST AT THE TIME OF PRINTING AND SUBJECT TO CHANGE WITHOUT NOTICE

NOTE: THE DC VOLTAGE AT EACH PART WAS MEASURED WITH THE DIGITAL TESTER WHEN THE COLOR BROADCAST WAS RECEIVED IN GOOD CONDITION AND PICTURE IS NORMAL



# DEFLECTION/CRT SCHEMATIC DIAGRAM

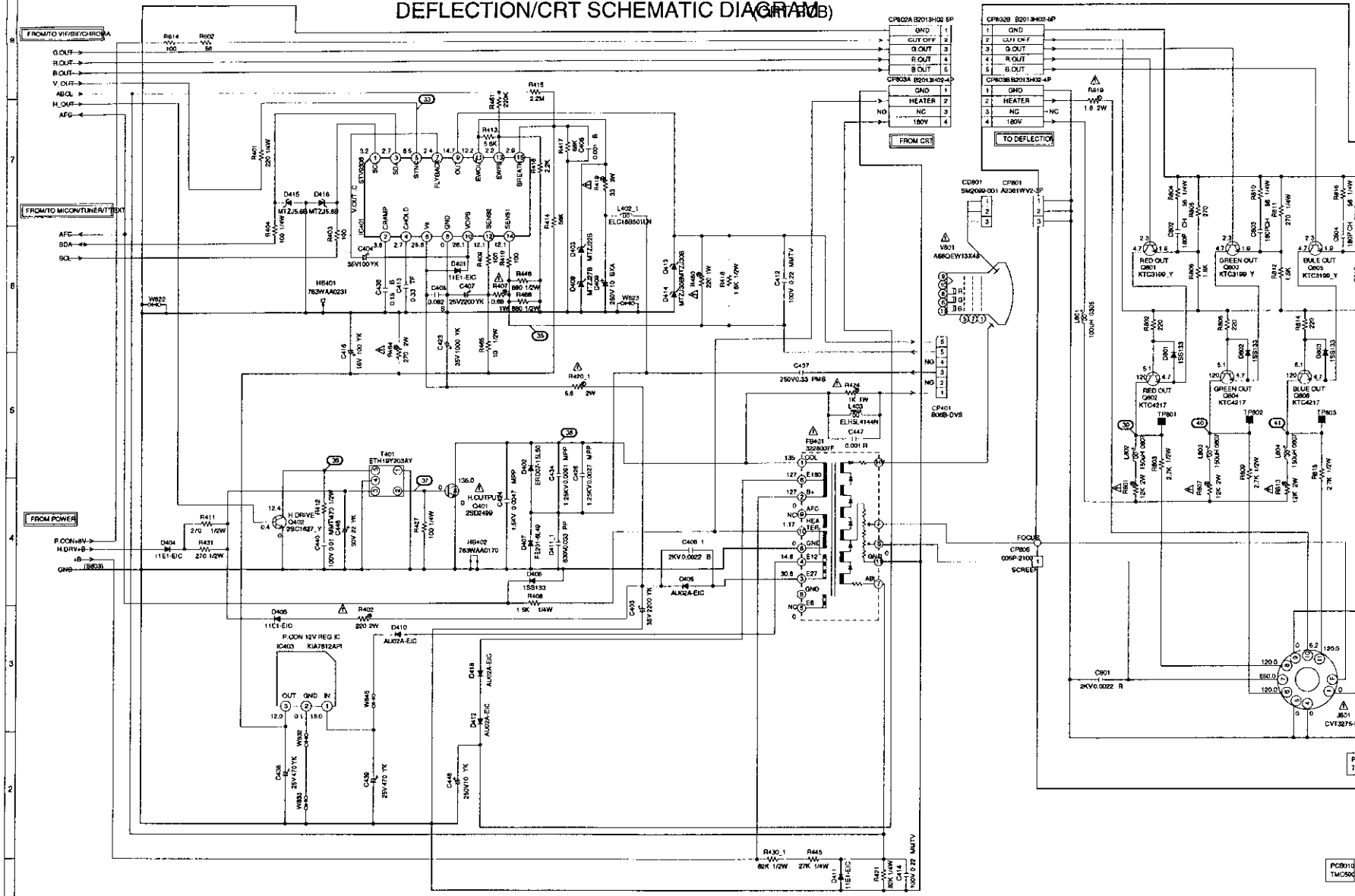

NOTE THIS SCHEMATIC DIAGRAM IS THE LATEST AT THE TIME OF PRINTING AND SUBJECT TO CHANGE WITHOUT NOTICE

NOTE THE DC VOLTAGE AT EACH PART WAS MEASURED WITH THE DIGITAL TESTER WHEN THE COLOR BROADCAST WAS RECEIVED IN GOOD CONDITION AND PICTURE IS NORMAL

ATTENTION: PIÈCES RÉPARÉES PARVENANT DANGEREUSES AN POINT DE VUE SECURITE NUTILISER QUE CELLS DÉCRITES DANS LA NOMENCLATURE DES PIÈCES

CAUTION: THESE PARTS MARKED ARE CRITICAL FOR SAFETY USE ONES DESCRIBED IN PARTS LIST ONLY

# POWER SCHEMATIC DIAGRAM (CB)

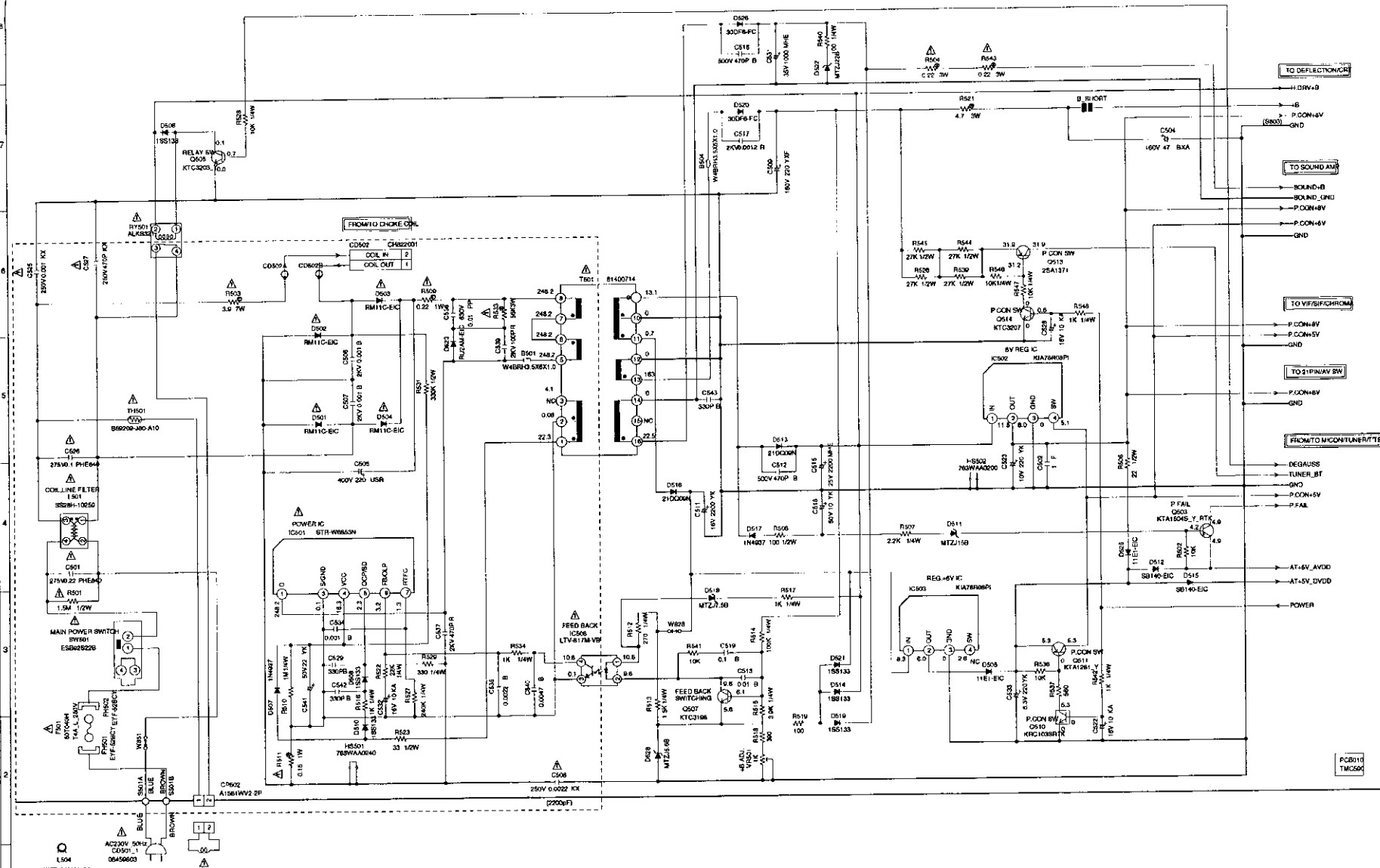

NOTES: THIS SCHEMATIC DIAGRAM IS THE LATEST AT THE TIME OF PRINTING AND SUBJECT TO CHANGE WITHOUT NOTICE.

NOTE: THE DC VOLTAGE AT EACH PART WAS MEASURED WITH THE DIGITAL TESTER WHEN THE COLOR SIGNAL WAS RECEIVED IN GOOD CONDITION AND PICTURE IS NORMAL.

**ATTENTION:** PIÈCES RÉPARÉES PAR UN POINT DE VUE SÉCURITÉ. UTILISER QUE CELLES DÉCRITES DANS LA NOMENCLATURE DES PIÈCES.

**CAUTION:** THESE PARTS MARKED ARE CRITICAL FOR SAFETY. USE ONES DESCRIBED IN PARTS LIST ONLY.

CAUTION: DIGITAL TRANSISTOR

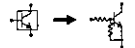

# SOUND AMP SCHEMATIC DIAGRAM (MAIN PCB)

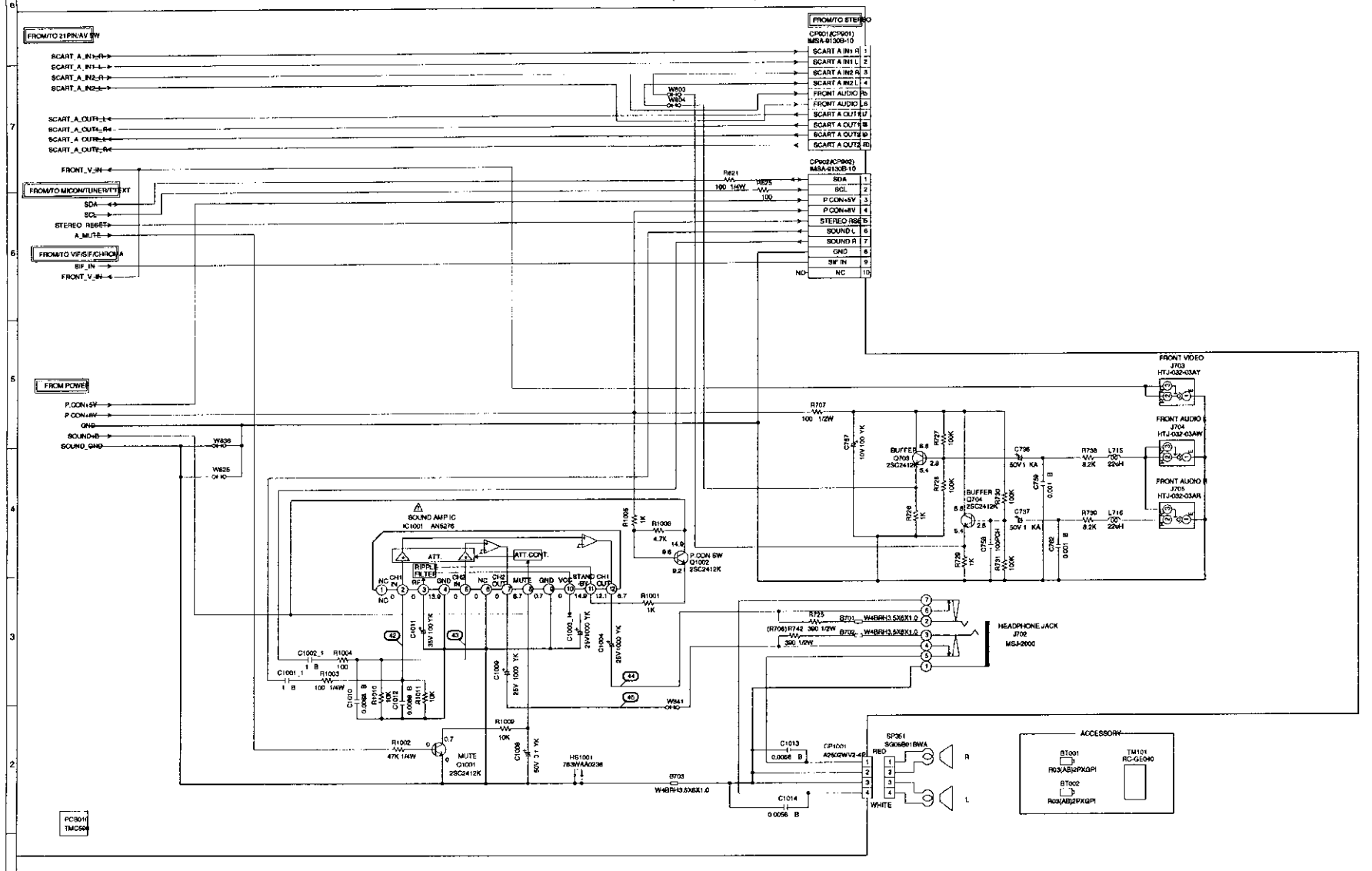

NOTE: THIS SCHEMATIC DIAGRAM IS THE LATEST AT THE TIME OF PRINTING AND SUBJECT TO CHANGE WITHOUT NOTICE.

NOTE: THE DC VOLTAGE AT EACH PART WAS MEASURED WITH THE DIGITAL TESTER WHEN THE COLOR BROADCAST WAS RECEIVED IN GOOD CONDITION AND PICTURE IS NORMAL.

**ATTENTION** DANGER USES AN POINT DE VUE SECURITE UTILISER QUE CELLS DECRIRES DANS LA NOMENCLATURE DES PIECES

**CAUTION** THESE PARTS MARKED ARE CRITICAL FOR SAFETY, USE ONES DESCRIBED IN PARTS LIST ONLY

# STEREO SCHEMATIC DTAGRAM (STEREO PCB)

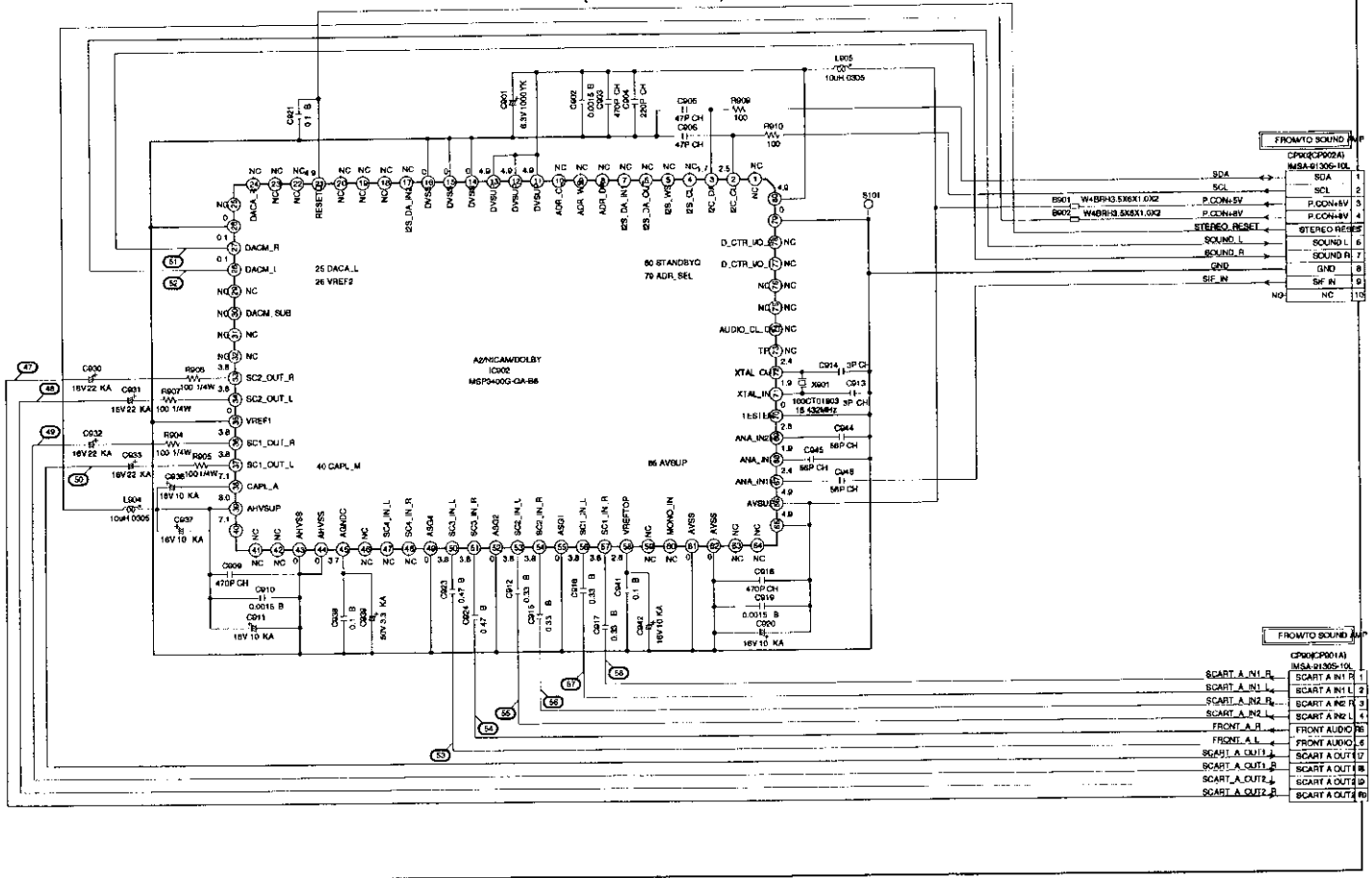

FROM TO SOUND	
C000(CP000A)	1
M5A-01306-0L	2
SCA	3
SCL	4
P.CONV.HV	5
P.CONV.LV	6
STEREO.RESET	7
SOUND.L	8
SOUND.R	9
GROUND	10
SIF.IN	11
NC	12

FROM TO SCART	
C000(CP001A)	1
M5A-01306-0L	2
SCART_A.IN1.L	3
SCART_A.IN1.R	4
SCART_A.IN2.L	5
SCART_A.IN2.R	6
FRONT_A.L	7
FRONT_A.R	8
SCART_A.OUT1.L	9
SCART_A.OUT1.R	10
SCART_A.OUT2.L	11
SCART_A.OUT2.R	12

NOTE: THIS SCHEMATIC DIAGRAM IS THE LATEST AT THE TIME OF PRINTING AND SUBJECT TO CHANGE WITHOUT NOTICE

NOTE: THE DC VOLTAGE AT EACH PART WAS MEASURED WITH THE DIGITAL TESTER WHEN THE COLOR BROADCAST WAS RECEIVED IN GOOD CONDITION AND PICTURE IS NORMAL

PCB200  
15AAM

# CHOKE COIL SCHEMATIC DIAGRAM (FILTER PCB)

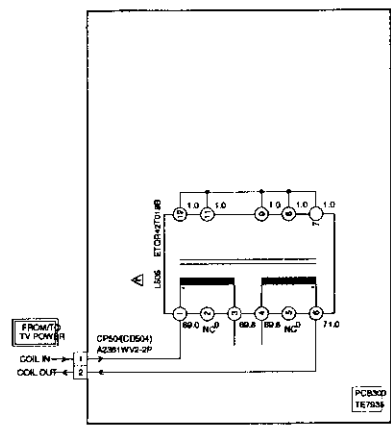

NOTE THIS SCHEMATIC DIAGRAM IS THE LATEST AT THE TIME OF PRINTING AND SUBJECT TO CHANGE WITHOUT NOTICE

NOTE THE DC VOLTAGE AT EACH PART WAS MEASURED WITH THE DIGITAL TESTER WHEN THE COLOR BROADCAST WAS RECEIVED IN GOOD CONDITION AND PICTURE IS NORMAL.

**ATTENTION** LES PIÈCES RÉPARÉES PAR UN MÉTANT DANGEREUSES AN POINT DE VUE SECURITE NUTILISER QUE CELLS DECRITES DANS LA NOMENCLATURE DES REÇES

**CAUTION** NOTICE THESE PARTS MARKED BY WIRE CRITICAL FOR SAFETY. USE ONES DESCRIBED IN PARTS LIST ONLY

# WAVEFORMS

## MICON/TUNER/TEXT

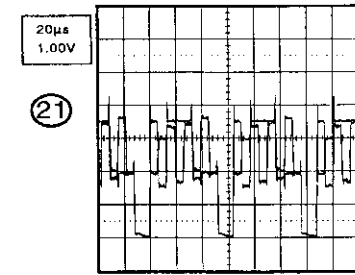
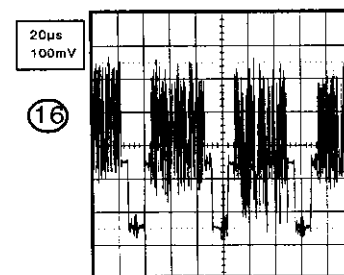
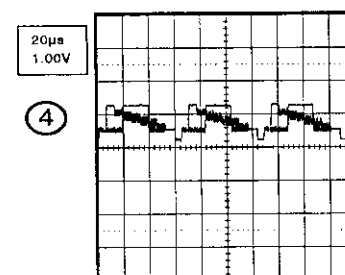
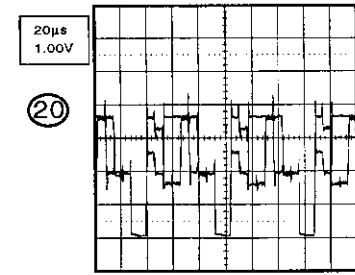
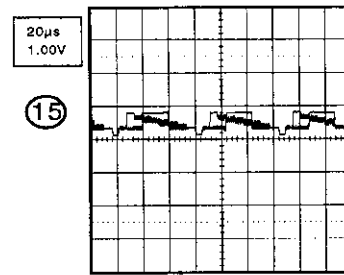
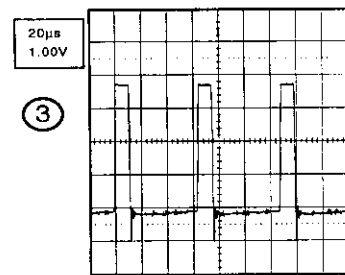
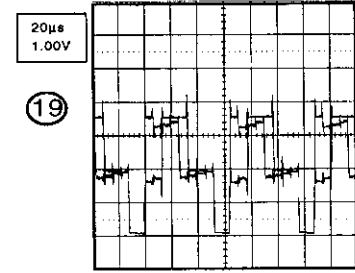
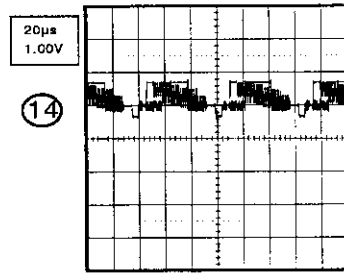
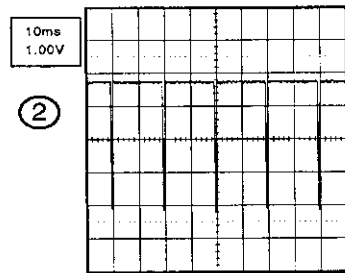
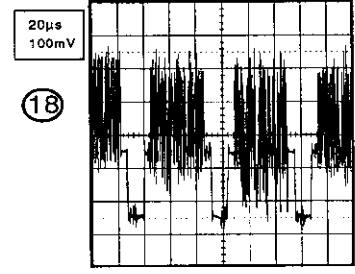
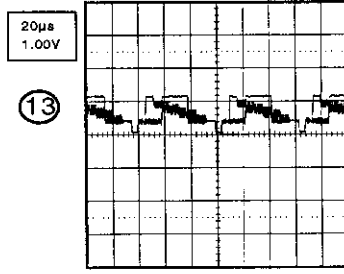
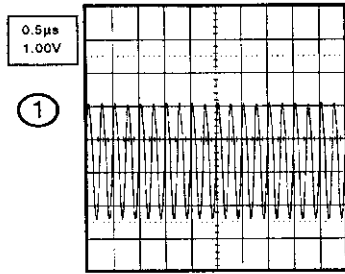

## VIF/SIF/CHROMA

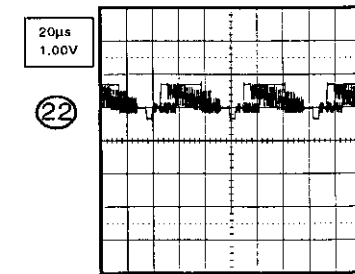
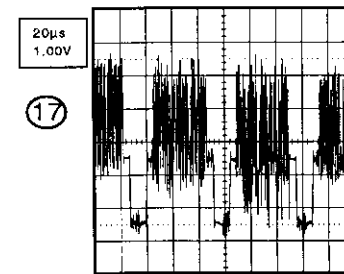
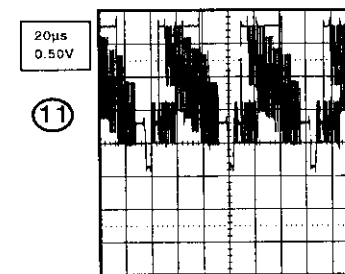

NOTE: The following waveforms were measured at the point of the corresponding balloon number in the schematic diagram.

## WAVEFORMS

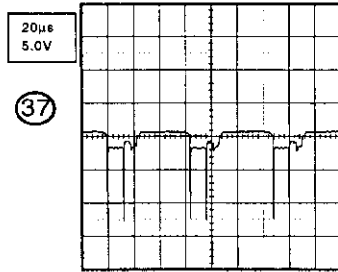
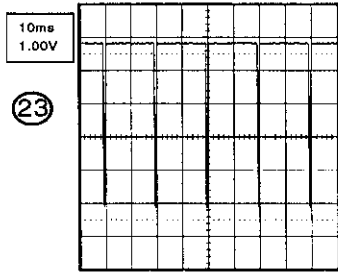

## SOUND AMP

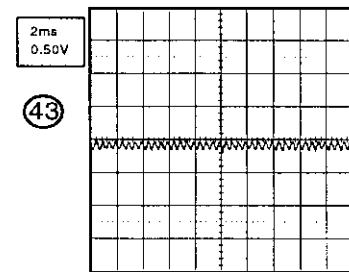
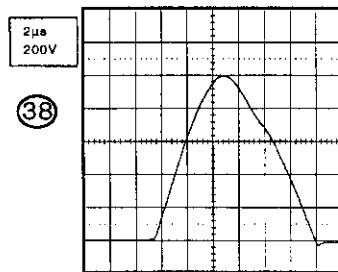
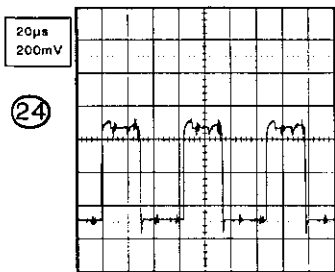
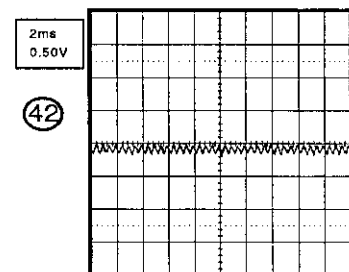

## DEFLECTION/CRT

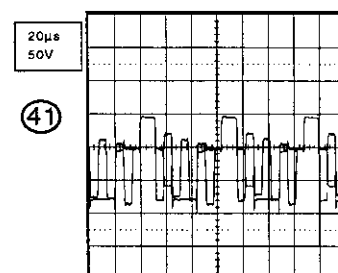
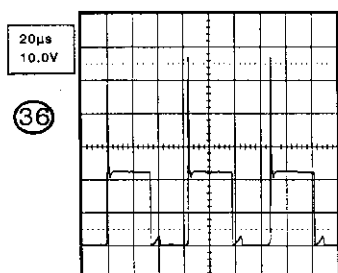
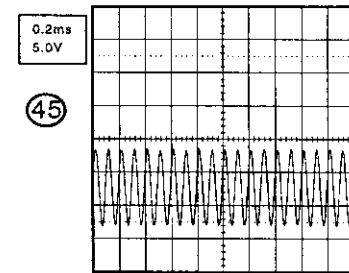
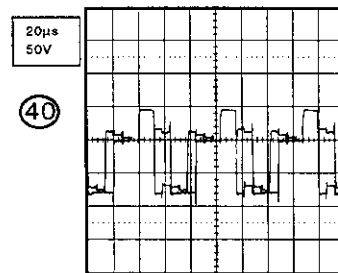
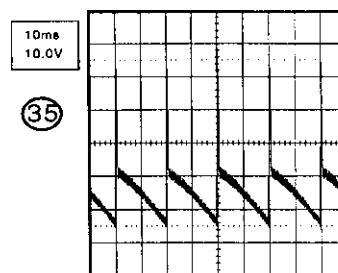
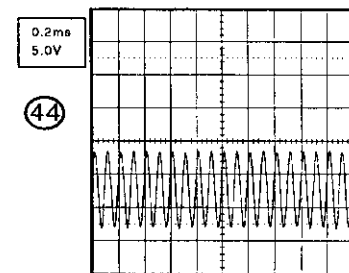
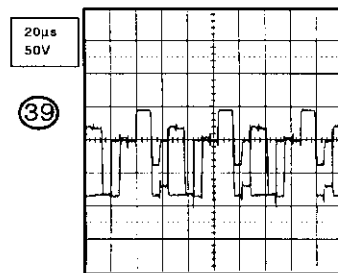
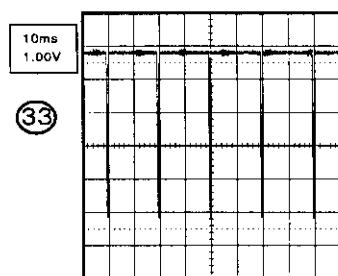

## STEREO

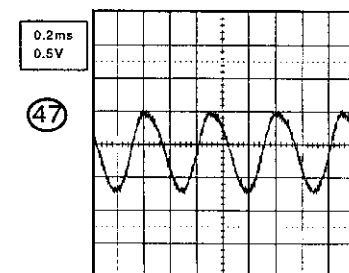

NOTE: The following waveforms were measured at the point of the corresponding balloon number in the schematic diagram.

# WAVEFORMS

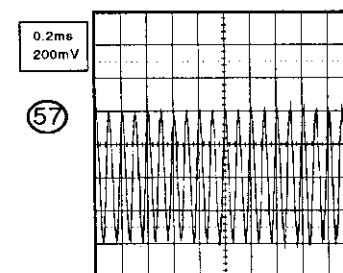
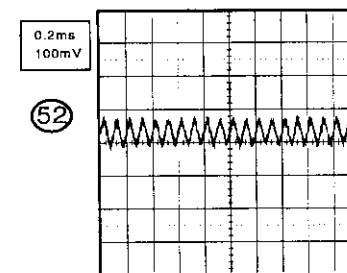
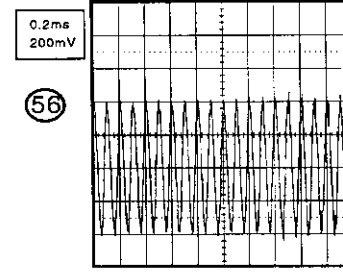
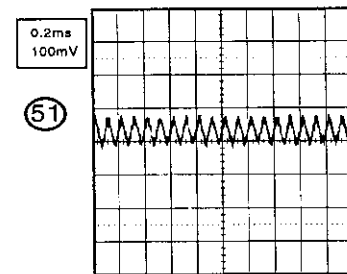
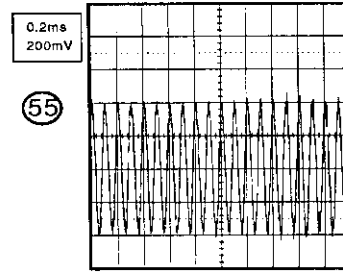
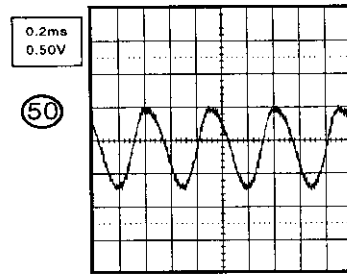
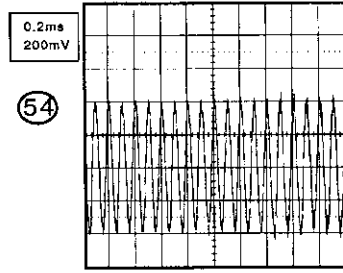
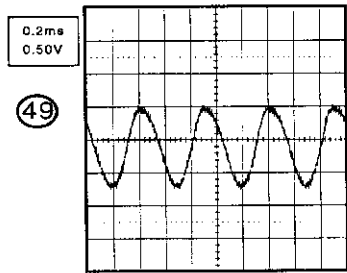
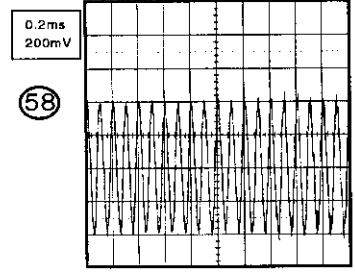
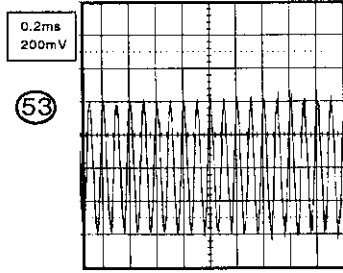
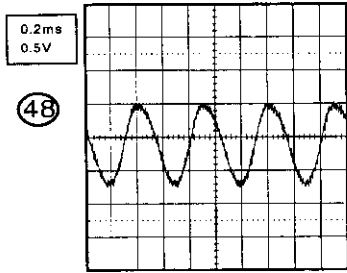

NOTE: The following waveforms were measured at the point of the corresponding balloon number in the schematic diagram.



# MECHANICAL EXPLODED VIEW

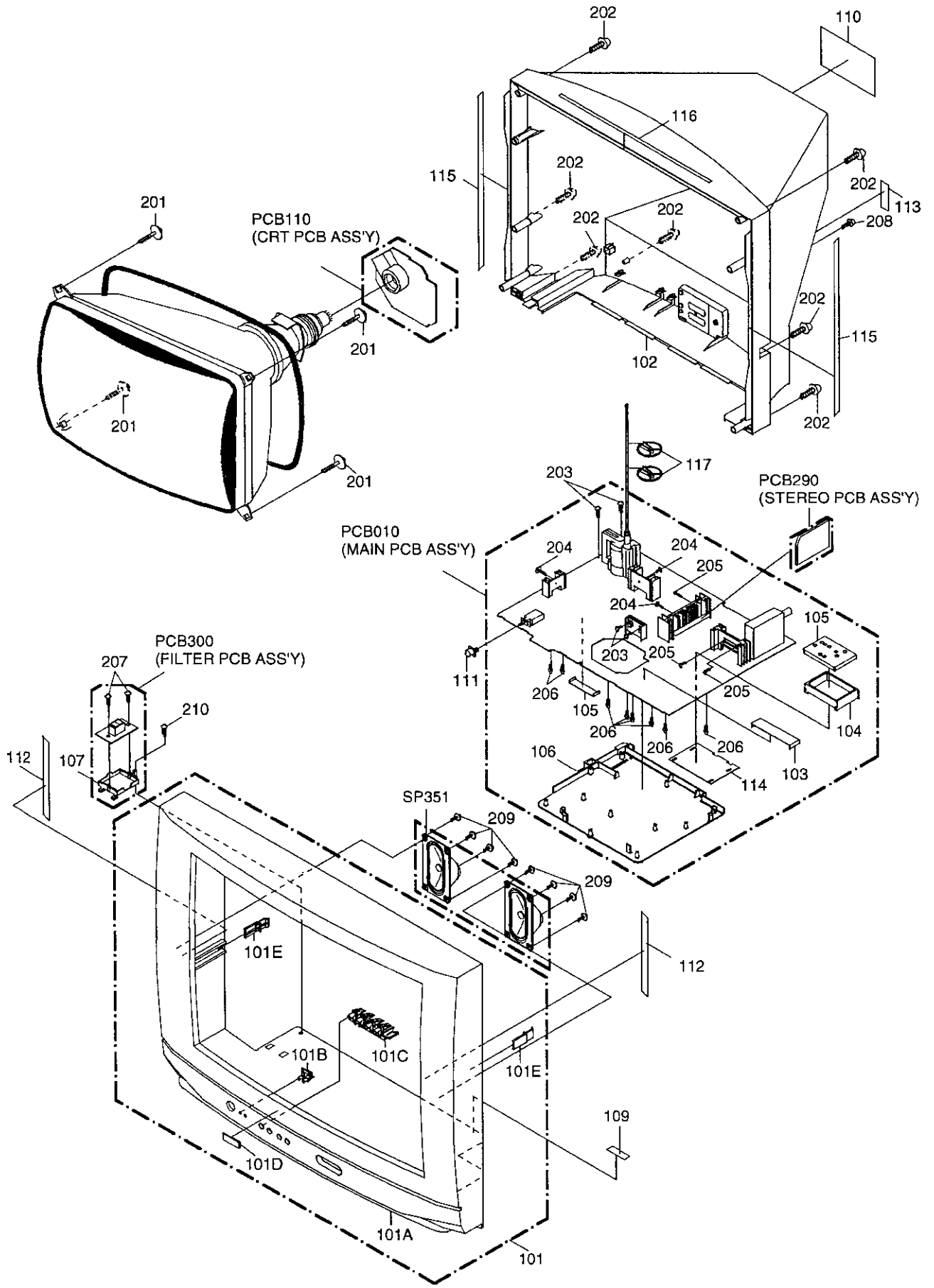

## MECHANICAL REPLACEMENT PARTS LIST

REF. NO.	PART NO.	DESCRIPTION
101	7A701A005A	CABINET,FRONT ASSY
101A	701UPJA138	CABINET,FRONT
101B	713UPA0024	GUIDE,REMOCON
101C	738UPBA006	BUTTON,FRAME
101D	7232020561	BADGE,BRAND
101E	709WPA0023	CABINET,HOLDER
102	A3P701K740	CABINET,BACK ASS'Y
103	752WSA0087	SHIELD,IC
104	752WSAA008	SHIELD,CASE
105	752WSAA013	SHIELD,LID
106	755WPA0016	COVER,PCB
107	761WPA0298	HOLDER,TRANS
108	899HV3T000	HOLDER,ANODE WIRE
109	722000A111	SHEET,PTB
110	722202A774	SHEET,RATING
111	735UPBA020	BUTTON,POWER
112	800UQ00010	FELT,SHEET
113	723000C402	SHEET,JACK
114	752WSAA006	PLATE,SHIELD
115	800WQ0A054	FELT,SHEET
116	800WQ0A071	FELT,SHEET
201	8111J50D05	SCREW,TAPPING(A) GW22 5x35
202	8117540B04	SCREW,TAPPING(B0) TRUSS 4x20
203	8110630A04	SCREW,TAP TITE(P) BRAZIER 3x10
204	8109130A04	SCREW,TAP TITE(B) WH7 3x10
205	8107630804	SCREW,TAP TITE(S) BRAZIER 3x8
206	8109630802	SCREW,TAP TITE(B) BRAZIER 3x8
207	8110630A24	SCREW,TAP TITE(P) BRAZIER 3x12
208	8110630804	SCREW,TAP TITE(P) BRAZIER 3x8
209	8117D30A04	SCREW,TAPPING(B0) WH8 BRAZIER 3x10
210	8117540A64	SCREW,TAPPING(B0) TRUSS 4x16
---	791WHAA046	LAMIFLIM BAG
---	792UHA0169	PACKAGE,TOP
---	792UHA0170	PACKAGE,BOTTOM
---	793UCDB269	GIFT BOX
---	J3P10101B	INSTRUCTION BOOK
---	JB5X0100	POLYBAG,INSTRUCTION
---	A3P101M975	INSTRUCTION BOOK KIT

## ELECTRICAL REPLACEMENT PARTS LIST

REF. NO.	PART NO.	DESCRIPTION	REF. NO.	PART NO.	DESCRIPTION
<b>RESISTORS</b>			<b>DIODES</b>		
△ R402	R3X18A221J	R,METAL OXIDE 220 OHM 2W	△ D502	D2WTRM11C0	DIODE SILICON RM11C-EIC
△ R407	R3X181R68J	R,METAL OXIDE 0.68 OHM 1W	△ D503	D2WTRM11C0	DIODE SILICON RM11C-EIC
△ R419	R3X28B330J	R,METAL OXIDE 33 OHM 3W	△ D504	D2WTRM11C0	DIODE SILICON RM11C-EIC
△ R420	R6558A5R6J	R,FUSE 5.6 OHM 2W	D505	D2WT011E10	DIODE SILICON 11E1-EIC
△ R424	R3K181102J	R,METAL 1K OHM 1W	D506	D1VT001330	DIODE,SILICON 1SS133T-77
△ R460	R3X181221J	R,METAL OXIDE 220 OHM 1W	D507	D2WXN49370	DIODE SILICON 1N4937
△ R484	R3X18A271J	R,METAL OXIDE 270 OHM 2W	D508	D1VT001330	DIODE,SILICON 1SS133T-77
△ R501	R002T2155J	RC 1.5M OHM 1/2W	D510	D1VT001330	DIODE,SILICON 1SS133T-77
△ R503	R5X2AE3R9J	R,CEMENT 3.9 OHM 7W	D511	D97U01501B	DIODE,ZENER MTZJ15B T-77
△ R504	R3X28BR22J	R,METAL 0.22 OHM 3W	D512	D2WXS81400	DIODE SCHOTTKY SB140-EIC
△ R509	R63581R22J	R,FUSE 5.6 OHM 2W	D513	D28T21DQ9N	DIODE SCHOTTKY 21DQ09N-TA2B1
△ R511	R3X181R15J	R,METAL OXIDE 0.15 OHM 1W	D514	D1VT001330	DIODE,SILICON 1SS133T-77
△ R521	R3X28B4R7J	R,METAL OXIDE 4.7 OHM 3W	D515	D2WXS81400	DIODE SCHOTTKY SB140-EIC
△ R527	R002T4244J	RC 240K OHM 1/4W	D516	D28T21DQ9N	DIODE SCHOTTKY 21DQ09N-TA2B1
△ R533	R3X28B563J	R,METAL 56K OHM 3W	D517	D2WXN49370	DIODE SILICON 1N4937
△ R543	R3X28BR22J	R,METAL 0.22 OHM 3W	D518	D97U07R51B	DIODE,ZENER MTZJ7.5B T-77
△ R801	R3X18A123J	R,METAL OXIDE 12K OHM 2W	D519	D1VT001330	DIODE,SILICON 1SS133T-77
△ R807	R3X18A123J	R,METAL OXIDE 12K OHM 2W	D520	D28F30DF60	DIODE RECTIFIER 30DF6-FC
△ R813	R3X18A123J	R,METAL OXIDE 12K OHM 2W	D521	D1VT001330	DIODE,SILICON 1SS133T-77
△ R819	R6558A1R8J	R,FUSE 1.8 OHM 2W	D522	D97U02201B	DIODE ZENER MTZJ22B T-77
<b>CAPACITORS</b>			D523	D2WXRU2AM0	DIODE SILICON RU2AM-EIC
C403	E0ELF4222M	CE 2200 UF 35V	D525	D2WT011E10	DIODE SILICON 11E1-EIC
C406	C0PWB07H3K	CC 0.0022UF 2KV B	D526	D28F30DF60	DIODE RECTIFIER 30DF6-FC
C407	E0ELF3222M	CE 2200 UF 25V	D528	D97U05R61B	DIODE,ZENER MTZJ5.6B T-77
C409	E62DFD100M	CE 10 UF 250V	D601	D97U09R11B	DIODE,ZENER MTZJ9.1B T-77
C411	P3N1F5333J	CPP 0.033 UF 630V	D603	D1VT001330	DIODE,SILICON 1SS133T-77
C423	E02L04102M	CE 1000 UF 35V	D604	D2WT011E10	DIODE SILICON 11E1-EIC
C424	P4N8FK472H	CMPP 0.0047UF 1.5KV	D606	D97U06R81B	DIODE,ZENER MTZJ6.8B T-77
C426	P4N8FJ272H	CMPP 0.0027UF 1.25KV	D607	D97U06R81B	DIODE,ZENER MTZJ6.8B T-77
C434	P4N8FJ912H	CMPP 0.0091UF 1.25KV	D608	D97U06R81B	DIODE,ZENER MTZJ6.8B T-77
C437	P4J7F3334J	CMPP 0.33 UF 250V PMS	D609	D1VT001330	DIODE,SILICON 1SS133T-77
C447	C0PLRR713K	CC 0.001 UF 2KV R	D610	D1VT001330	DIODE,SILICON 1SS133T-77
△ C501	P2472B224M	CMP 0.22UF 275V PHE840	D611	D1VT001330	DIODE,SILICON 1SS133T-77
C504	E62DFB470M	CE 47 UF 160V	D612	D28T21DQ9N	DIODE SCHOTTKY 21DQ09N-TA2B1
C505	E52D0H221M	CE 220 UF 400V	D712	D97U05R61B	DIODE,ZENER MTZJ5.6B T-77
C506	C0JBB0713K	CC 0.001 UF 2KV B	D723	D97U05R61B	DIODE,ZENER MTZJ5.6B T-77
C507	C0JBB0713K	CC 0.001 UF 2KV B	D801	D1VT001330	DIODE,SILICON 1SS133T-77
△ C508	CD39E0MH3M	CC 0.0022UF 250V	D802	D1VT001330	DIODE,SILICON 1SS133T-77
C509	E62NFB221M	CE 220 UF 160V	D803	D1VT001330	DIODE,SILICON 1SS133T-77
C511	E02LF2222M	CE 2200 UF 16V	<b>ICS</b>		
C515	E5EZF3222M	CE 2200 UF 25V	IC101	I5P0F008B	IC OECF008B
C517	C03L0R7B3K	CC 0.0012UF 2KV R	IC102	IC7J0311A0	IC R3111N311A/C-TR
△ C525	CD39E0M13M	CC 0.001 UF 250V	IC199	A3P701K015	IC S-24C04BFJ-TB
△ C526	P2472B104M	CMP 0.1 UF 275V PHE840	IC201	I0WDE2248C	IC STV2248C
△ C527	CD39B0MQ2K	CC 470 PF 250V	IC401	I0WTE93060	IC STV9306
C531	E5EZ4102M	CE 1000 UF 35V	IC403	I1KA97812A	IC KIA7812API
C536	P3N1F5103J	CPP 0.01 UF 630V	IC501	I2B0853N0	IC STR-W6853N
C537	C0PLRR7Q2K	CC 470 PF 2KV R	IC502	I1KA978R08	IC KIA78R08PI
C539	C0PLRR712K	CC 100 PF 2KV R	△ IC503	I1KA978R06	IC KIA78R06PI
C801	C03L0R7H3K	CC 0.0022UF 2KV R	△ IC506	0002E00610	PHOTO COUPLER LTV-817M-VB
C901	E02L00102M	CE 1000 UF 6.3V	IC702	I0UF015010	IC MM1501XNRE
C1004	E02LF3102M	CE 1000 UF 25V	IC902	I19FF34000	IC MSP3400G-QA-B8
C1009	E02LF3102M	CE 1000 UF 25V	IC1001	I0FSP52760	IC AN5276
<b>DIODES</b>			<b>TRANSISTORS</b>		
D001	D97U03301B	DIODE,ZENER MTZJ33B T-77	Q103	TAAA1504SY	TRANSISTOR SILICON KTA1504S_Y_RTK
D101	0021721150	LED SLR-342VCT32	Q201	T8AA03881S	TRANSISTOR SILICON KTC3881S-RTK
D102	D97U05R11B	DIODE,ZENER MTZJ5.1B T-77	Q202	T8YJ2412K0	TRANSISTOR SILICON 2SC2412KT146 R,S
D105	D1VT001330	DIODE,SILICON 1SS133T-77	Q204	T8YJ2412K0	TRANSISTOR SILICON 2SC2412KT146 R,S
D108	D1VT001330	DIODE,SILICON 1SS133T-77	Q301	T8AA03881S	TRANSISTOR SILICON KTC3881S-RTK
D401	D2WT011E10	DIODE SILICON 11E1-EIC	Q401	TDFU024990	TRANSISTOR SILICON 2SD2499
D402	D2CF0715L0	DIODE SILICON ERD07-15L50	Q402	TC5T01627Y	TRANSISTOR SILICON 2SC1627_Y(TPE2)
D403	D97U02201B	DIODE ZENER MTZJ22B T-77	Q503	TAAA1504SY	TRANSISTOR SILICON KTA1504S_Y_RTK
D404	D2WT011E10	DIODE SILICON 11E1-EIC	Q505	TCAT032034	TRANSISTOR, SILICON KTC3203_Y-AT
D405	D2WTAU02A0	DIODE SILICON AU02A-EIC	Q507	TCATC31980	TRANSISTOR,SILICON KTC3198-AT(Y,GR)
D406	D2WT011E10	DIODE SILICON 11E1-EIC	Q510	TNAAC05002	COMPOUND TRANSISTOR KRC103SRTK
D407	D2CF2016L0	DIODE SILICON FE201-6L49	Q511	TAAT01281Y	TRANSISTOR SILICON KTA1281_Y
D408	D1VT001330	DIODE,SILICON 1SS133T-77	Q513	TA3T1371A0	TRANSISTOR,SILICON 2SA1371(D,E)-AE
D409	D97U02701B	DIODE,ZENER MTZJ27B T-77	Q514	TCAT032070	TRANSISTOR SILICON KTC3207-AT
D410	D2WTAU02A0	DIODE SILICON AU02A-EIC	Q601	T8YJ2412K0	TRANSISTOR SILICON 2SC2412KT146 R,S
D411	D2WT011E10	DIODE SILICON 11E1-EIC	Q602	TPAAB05001	COMPOUND TRANSISTOR KRA102SRTK
D412	D2WTAU02A0	DIODE SILICON AU02A-EIC	Q603	T8YJ2412K0	TRANSISTOR SILICON 2SC2412KT146 R,S
D413	D97U03001B	DIODE,ZENER MTZJ30B T-77	Q609	T8YJ2412K0	TRANSISTOR SILICON 2SC2412KT146 R,S
D414	D97U03001B	DIODE,ZENER MTZJ30B T-77	Q701	TAATA12660	TRANSISTOR,SILICON KTA1266-AT(Y,GR)
D415	D97U05R61B	DIODE,ZENER MTZJ5.6B T-77	Q702	TAATA12660	TRANSISTOR,SILICON KTA1266-AT(Y,GR)
D416	D97U05R61B	DIODE,ZENER MTZJ5.6B T-77	Q703	T8YJ2412K0	TRANSISTOR SILICON 2SC2412KT146 R,S
D418	D2WTAU02A0	DIODE SILICON AU02A-EIC	Q704	T8YJ2412K0	TRANSISTOR SILICON 2SC2412KT146 R,S
△ D501	D2WTRM11C0	DIODE SILICON RM11C-EIC	Q711	T8YJ2412K0	TRANSISTOR SILICON 2SC2412KT146 R,S

## ELECTRICAL REPLACEMENT PARTS LIST

REF. NO.	PART NO.	DESCRIPTION	REF. NO.	PART NO.	DESCRIPTION
<b>TRANSISTORS</b>			<b>MISCELLANEOUS</b>		
Q801	TCATC3199Y	TRANSISTOR SILICON KTC3199_Y-AT	B901	024HT03563	CORE,BEADS W4BRH3.5X6X1.0X2
Q802	TCA0042170	TRANSISTOR SILICON KTC4217(O,Y)	B902	024HT03563	CORE,BEADS W4BRH3.5X6X1.0X2
Q803	TCATC3199Y	TRANSISTOR SILICON KTC3199_Y-AT	BT001	1412004013	BATTERY,MANGAN R03(AB)2PXGPI
Q804	TCA0042170	TRANSISTOR SILICON KTC4217(O,Y)	BT002	1412004013	BATTERY,MANGAN R03(AB)2PXGPI
Q805	TCATC3199Y	TRANSISTOR SILICON KTC3199_Y-AT	△ CD501	1206459803	CORD AC BUSH 6459803
Q806	TCA0042170	TRANSISTOR SILICON KTC4217(O,Y)	CD502	06CH822001	CORD CONNECTOR CH822001
Q1001	T8YJ2412K0	TRANSISTOR SILICON 2SC2412KT146 R,S	CD801	1278280010	BRAIDED WIRE SM2099-001
Q1002	T8YJ2412K0	TRANSISTOR SILICON 2SC2412KT146 R,S	CD802	WCL6848038	FLAT CABLE AWM2468 AWG26 5C GRAY 480MM
<b>COILS &amp; TRANSFORMERS</b>			CD803	WBL6040038	FLAT CABLE AWM2468 AWG26 4C BLACK 400MM
L001	02167F100J	COIL 10 UH	CF201	1012T5R503	FILTER,CERAMIC TRAP TPS5.5MB-TF21
L101	02167F100J	COIL 10 UH	CF202	102E038R9B	FILTER,SAW K3953M
L102	02167F100J	COIL 10 UH	CF204	1012T03101	FILTER CERAMIC TRAP MKT31.9MA110P-TF
L202	033700005R	COIL,VIDEO IFT 3700005	CF301	1022133R41	FILTER,SAW SAFGM33M4VC0Z00B03
L203	021LA62R2K	COIL 2.2 UH	CF303	1012T04001	FILTER,CERAMIC TRAP MKT40.4MA110P-TF
L204	021LA6120J	COIL 12 UH	CP001	069D01001A	CONNECTOR PCB SIDE 003P-2100
L206	021LA6R22M	COIL 0.22 UH	CP101	069X160379	CONNECTOR PCB SIDE 06JQ-ST
L207	021LA6100J	COIL 10 UH	CP401	069X460029	CONNECTOR PCB SIDE B06B-DVS
L208	02167F3R3J	COIL 3.3 UH	CP502	069S420110	CONNECTOR PCB SIDE A1561WV2-2P
L301	021LA62R2K	COIL 2.2 UH	CP504	069S320010	CONNECTOR PCB SIDE A2361WV2-2P
L302	021LA6R22M	COIL 0.22 UH	CP601	069S330010	CONNECTOR PCB SIDE A2361WV2-3P
L303	021LA61R0M	COIL 1 UH	CP606	069W010010	CONNECTOR PCB SIDE 005P-2100
L402	02D3000057	COIL CHOKE ELC18B501LN	CP901	069J1A0048	CONNECTOR PCB SIDE IMSA-9130S-10L
L403	0221000037A	COIL,LINEARITY ELH5L4144N	CP902	069J1A0048	CONNECTOR PCB SIDE IMSA-9130S-10L
△ L501	029X000096	COIL,LINE FILTER SS28H-10250	CP1001	069S140419	CONNECTOR PCB SIDE A2502WV2-4P
△ L503	028R280003	COIL,DEGAUSS 8R280003	CP802A	067U005049	WIRE HOLDER B2013H02-5P
L504	02AHB0A0A4	CORE,FERRITE W5T_20*10*10A	CP802B	067U005049	WIRE HOLDER B2013H02-5P
△ L505	02D1000060	COIL CHOKE ETQR42T018B	CP803A	067U004029	WIRE HOLDER B2013H02-4P
L601	02167F100J	COIL 10 UH	CP803B	067U004029	WIRE HOLDER B2013H02-4P
L701	021LA6220J	COIL 22 UH	CP901A	069J1A0038	CONNECTOR PCB SIDE IMSA-9130B-10
L702	021LA6220J	COIL 22 UH	CP902A	069J1A0038	CONNECTOR PCB SIDE IMSA-9130B-10
L703	021LA6220J	COIL 22 UH	EL001	124120301A	EYE LET XRY20X30BD
L705	021LA6220J	COIL 22 UH	EL002	124116281A	EYE LET XRY16X28BD
L706	021LA6220J	COIL 22 UH	△ F501	080NT04004	FUSE 50T040H
L707	021LA6220J	COIL 22 UH	△ FB401	043228007F	TRANSFORMER,FLYBACK 3228007F
L708	021LA6220J	COIL 22 UH	FH501	06710T0009	HOLDER,FUSE EYF-52BCY
L709	021LA6220J	COIL 22 UH	FH502	06710T0009	HOLDER,FUSE EYF-52BCY
L710	021LA6220J	COIL 22 UH	OS101	0773071001	REMOTE RECEIVER RPM7138-WH5
L711	021LA6220J	COIL 22 UH	△ RY501	0560V20115	RELAY ALKS321
L713	02167F100J	COIL 10 UH	△ SP351	070C555007	SPEAKER SG05B01BWA
L715	021LA6220J	COIL 22 UH	△ TH501	D8E080A100	DEGAUSS ELEMENT B59209-J80-A10
L716	021LA6220J	COIL 22 UH	TM101	076N0GE040	TRANSMITTER RC-GE040
L717	021LA6100J	COIL 10 UH	TU001	0145517007	TUNER,VHF-UHF TUWRF4EG-778F2A
L801	02167F101J	COIL 100 UH	△ V801	098A280501	CRT W/DY A66QEW13X48
L802	02167D151K	COIL 150 UH	X101	100CT4R013	CRYSTAL HC-49U-S
L803	02167D151K	COIL 150 UH	X601	100CT4R408	CRYSTAL HC-49U
L804	02167D151K	COIL 150 UH	X901	100CT01803	CRYSTAL HC-49U-S
L904	02167F100J	COIL 10 UH	<b>RESISTOR</b> RC..... CARBON RESISTOR  <b>CAPACITORS</b> CC..... CERAMIC CAPACITOR CE..... ALUMI ELECTROLYTIC CAPACITOR CP..... POLYESTER CAPACITOR CPP..... POLYPROPYLENE CAPACITOR CPL..... PLASTIC CAPACITOR CMP..... METAL POLYESTER CAPACITOR CML..... METAL PLASTIC CAPACITOR CMPP..... METAL POLYPROPYLENE CAPACITOR		
L905	02167F100J	COIL 10 UH			
T401	0450190161	TRANS,HORIZONTAL DRIVE ETH19Y203AY			
△ T501	0481400714	TRANSFORMER,SWITCHING 81400714			
<b>JACKS</b>					
J701	063G100041	SOCKET,21PIN 035_0_8083_00			
J702	060J131015	HEADPHONE JACK MSJ-2000			
J703	060G401047	RCA JACK HTJ-032-03AY			
J704	060G401046	RCA JACK HTJ-032-03AW			
J705	060G401039	RCA JACK HTJ-032-03AR			
△ J801	066C130017	SOCKET,CATHODE RAY TUBE CVT3275-5101			
<b>SWITCHES</b>					
SW102	0504201T31	SWITCH,TACT SKHVBED010			
SW104	0504201T31	SWITCH,TACT SKHVBED010			
SW106	0504201T31	SWITCH,TACT SKHVBED010			
SW107	0504201T31	SWITCH,TACT SKHVBED010			
△ SW501	0530105019	SWITCH ESB92S22B			
<b>VARIABLE RESISTOR</b>					
VR501	V116313BTC	VOLUME,SEMI FIXED EVNCYAA03B13			
<b>P.C. BOARD ASSEMBLIES</b>					
PC8010	A3P701K010K	PCB ASSY TMC590A			
PC8110	A3P701K110K	PCB ASSY TCC447A			
PC8290	A3P701K290K	PCB ASSY TEAA89A			
PC8300	A3P701K300K	PCB ASSY TE7935A			
<b>MISCELLANEOUS</b>					
B501	024HT03564	CORE,BEADS W4BRH3.5X6X1.0			
B504	024HT03564	CORE,BEADS W4BRH3.5X6X1.0			
B602	024HT03553	CORE,BEADS W5FRH3.5X5X1.0			
B701	024HT03564	CORE,BEADS W4BRH3.5X6X1.0			
B702	024HT03564	CORE,BEADS W4BRH3.5X6X1.0			
B703	024HT03564	CORE,BEADS W4BRH3.5X6X1.0			

SPEC.NO.	M3P7-01K
O/R NO.	U413501

# ORION

## TV-719

# SERVICE MANUAL

**COLOR TELEVISION RECEIVER**

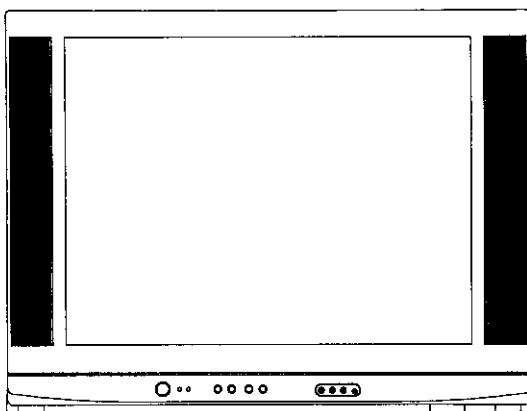

**SUPPLEMENT  
CHASSIS CODE A**

This SUPPLEMENT must be used together SERVICE MANUAL for TV-719 S1.  
All other test and repair procedures are as shown in the ORIGINAL MANUAL.  
Please file this SUPPLEMENT with the ORIGINAL VERSIONS.

## ELECTRICAL REPLACEMENT PARTS LIST

REF. NO.	TV-719 SI		TV-719	
	PART NO.	DESCRIPTION	PART NO.	DESCRIPTION
TM101	076N0GE040	TRANSMITTER RC-GE040	076N0GE020	TRANSMITTER RC-GE020

## MECHANICAL REPLACEMENT PARTS LIST

REF. NO.	TV-719 SI		TV-719	
	PART NO.	DESCRIPTION	PART NO.	DESCRIPTION
101	7A701A005A	FRONT,CABI ASS'Y	7A701A143A	FRONT,CABI ASS'Y
101A	701UPJA138	CABINET,FRONT	701UPJA146	CABINET,FRONT
101C	738UPBA006	BUTTON,FRAME	738UPA0004	BUTTON,FRAME
102	A3P701K740	CABINET,BACK ASS'Y	A3P712K740	CABINET,BACK ASS'Y
110	722202A774	SHEET,RATING	722202A825	SHEET,RATING
111	735UPBA020	BUTTON,POWER	735UPA0101	BUTTON,POWER
---	793UCDB269	GIFT BOX	793UCDB355	GIFT BOX

SPEC.NO.	M3P7-12K
O/R NO.	U463563