

ORION

TRIADA34

MODEL

SERVICE MANUAL

ICN1	S063187329	IC TDA8732	IC TDA8732
ICN5/ICN6	S063355329	IC NE5532	IC NE5532
ICN2	S063372809	IC SAA7280	IC SAA7280
QN1	S066900429	Quarz 11,7 MHz	Quarzo 11,7 MHz
QN2	S066900679	Quarz 17,472 MHz	Quarzo 17,472 MHz
CFN1	S067335009	Filter 5,85 MHz	Filtro 5,85 MHz
	S000744909	TEXT PCB 4900 cpl.	MODULO TELEVIDEO 4900 cpl.
	S000744919	TEXT PCB 4900 TOP cpl.	MODULO TELEVIDEO 4900 TOP cpl.
	S000744929	TEXT PCB 4900 FLOF cpl.	MODULO TELEVIDEO 4900 FLOF cpl.
ICT2	S063185719	IC ST24C02 (TOP-FLOF)	IC ST24C02 (TOP-FLOF)
ICT1	S063283659	IC PCB 83C654P/AC013 (TOP)	IC PCB83C654P/AC013 (TOP)
ICT1	S063284819	IC PCF84C81P/049 (FLOF)	IC PCF84C81P/049 (FLOF)
ICT3	S063352469	IC SAA5246P/E	IC SAA5246P/E
ICT4	S063355659	IC FCB61C65L	IC FCB61C65L
QT1	S066900909	Quarz 9,8304 MHz (FLOF)	Quarzo 9,8304 MHz (FLOF)
QT1	S066901209	Quarz 12 MHz (TOP)	Quarzo 12 MHz (TOP)
QT2	S066902709	Quarz 27 MHz	Quarzo 27 MHz
	S000784909	PIP PCB 4900 BG cpl.	MODULO PIP 4900 BG cpl.
CE27	S012018009	Ceramic condensator NPO 18 pF	Condensatore cer. NP0 18 pF
CE8	S014156009	Ceramic condensator NPO 560 pF	Condensatore cer. NP0 560 pF
CE10	S040451489	Condensator 4,7 uF	Condensatore 4,7 uF
RE81/RE82/RE83			
RE85/RE86	S047004709	Fuse resistor 4,7 Ohm	Resistenza fusibile 4,7 Ohm
RE4/RE53	S047010009	Fuse resistor 10 Ohm	Resistenza fusibile 10 Ohm
ZE2	S061961409	Zener diode ZPD 5,1	Diodo zener ZPD 5,1
ZE1/ZE3	S061961509	Zener diode ZPD 5,6	Diodo zener ZPD 5,6
TE7	S062520349	Transistor BC640	Transistor BC640
TE13	S062528009	Transistor BD202	Transistor BD202
ICE10	S063112109	IC TDA1905	IC TDA1905
ICE4	S063125799	IC TDA2579A	IC TDA2579A
ICE2	S063146509	IC TDA4650 (Pal-Secam)	IC TDA4650 (Pal-Secam)
ICE2	S063145109	IC TDA4510 (Pal)	IC TDA4510 (Pal)
ICE3	S063146609	IC TDA4661	IC TDA4661
ICE11	S063151149	IC TEA5114A	IC TEA5114A
ICE1	S063162009	IC TEA2014A	IC TEA2014A
ICE9	S063181969	IC TDA8196	IC TDA8196
ICE12	S063249409	IC L4940V12	IC L4940V12
ICE7	S063390869	IC SDA9086-3	IC SDA9086-3
ICE5	S063390879	IC SDA9087	IC SDA9087
ICE6	S063390889	IC SDA9088-2	IC SDA9088-2
QE1	S066900109	Quarz 8,867 MHz	Quarzo 8,867 MHz
	S069027009	Front-end FQ816-IF-PLL BG	Front-end FQ816-IF-PLL BG
	S069310009	PIP-Power splitter (PWS5001)	PIP-Power splitter (PWS5001)
	S092423909	PIP 4900 RF cable	Cavo antenna PIP 4900
	S000794909	DYNAMIC FOCUS PCB cpl.	MODULO FUOCO DINAMICO cpl.
CFD1	S020116809	Condensator 680 pF 3000V	Condensatore 680 pF 3000V
VDR1/VDR2	S056592109	VDR resistor	Resistenza VDR
	S058549009	Dynamic focus potentiometer	Potenzimetro fuoco dinamico
LFD1	S066830109	Dynamic focus coil AT 4043/67A	Trasduttore AT 4043/67A

ICP2	S063249459	IC L4940V5	IC L4940V5
TRL1	S065621109	EHT trafo	Trasformatore EAT
	S065625609	EHT cable	Cavo EAT
TRP1	S065704609	SMPS Mains Trafo	Trasformatore alimentazione
LP1	S066542009	Mains filter	Filtro rete
TRP2	S066831009	Trigger Trafo	Trasduttore trigger
LG1	S067071009	E/W injection coil	Bobina E/W
LL3	S067081409	Linearity coil	Bobina linearità
QL1	S067330109	Ceramic resonator CSB503F12	Risuonatore cer. CSB503F12
RL1	S068070809	Relais	Relais
	S092503709	Power cord cpl.	Cavo rete cpl.
	S000594909	I/O PCB 16:9 cpl.	MODULO INTERFACCIA I/O 16:9 cpl.
ICY1	S063440119	IC HEF 4011-BP	IC HEF 4011-BP
ICY2	S063440139	IC HEF 4013-BP	IC HEF 4013-BP
ICY6	S063440229	IC HEF 4022-BP	IC HEF 4022-BP
ICY4/ICY5	S063445179	IC HEF 4517-BP	IC HEF 4517-BP
ICY3	S063445579	IC HEF4557-BP	IC HEF 4557-BP
	S000614939	SCART 2 PCB cpl.	MODULO SCART 2 cpl.
ICW1	S063184409	IC TDA8440	IC TDA8440
ICW2	S063151149	IC TEA5114A	IC TEA5114A
	S071014009	SCART connector	Presca SCART
	S000664939	CHROMA PCB 4900 PAL cpl.	MODULO CROMA 4900 PAL cpl.
CC31	S014156009	Ceramic condensator NPO 560 pF	Condensatore cer. NPO 560 pF
CVC1	S044613309	Trimmer 30 pF	Compensatore 30 pF
ZC1	S061961159	Zener diode ZPD 4V3	Diodo zener ZPD4V3
ZC2	S061961409	Zener diode ZPD 5V1	Diodo zener ZPD 5V1
ICC5	S063135059	IC TDA 3505	IC TDA 3505
ICC3	S063145659	IC TDA 4565	IC TDA 4565
ICC2	S063145109	IC TDA 4510	IC TDA 4510
ICC4	S063146609	IC TDA 4661	IC TDA 4661
ICC1	S063167009	IC TEA 5115	IC TEA 5115
QC1	S066900109	Quarz 8,86 MHz	Quarzo 8,86 MHz
	S071014109	SCART Connector	Presca Scart
	S071020009	S-VHS connector	Presca S-VHS
	S000674939	CRT PCB 16:9 cpl.	MODULO ZOCCOLO CINESC. 16:9 cpl.
CV17	S035931019	Condensator 10 nF 1000V	Condensatore 10 nF 1000V
CV19	S040590229	Elko 2,2 uF 250v	Condensatore elettr. 2,2 uF 250V
CV16	S040600229	Elko 22 uF	Condensatore chimico 22 uF
TV3	S062740869	Transistor BF 871	Transistor BF 871
ICV1/ICV2/			
ICV3	S063170009	IC TDA 6101Q/N2	IC TDA 6101Q/N2
	S070001609	CRT connector CVT 3251-0175	Zoccolo cinescopio CVT 3251-0175
	S000694919	NICAM PCB 4900 cpl.	MODULO NICAM 4900 cpl.
CN11/CN12	S014118009	Ceramic condensator NPO 180 pF	Condensatore cer. NPO 180 pF
CN14/CN26	S014210009	Ceramic condensator NPO 1 nF	Condensatore cer. NPO 1 nF
RN17/RN18/			
RN19/RN20	S050710339	Resistor 3,3 Ohm 1 W	Resistenza 3,3 Ohm 1 W
DN1	S061296509	Diode BB405B	Diodo BB405B
DN3	S061298009	Diode BB809	Diodo BB809
TN4	S062520349	Transistor BC640	Transistor BC640
TN2	S062720009	Transistor BF240	Transistor BF240
ICN4	S063115439	IC TDA1543	IC TDA1543

DIAPASON 36			
TRIADE 9203			
	S000844949	MANUALS CONTROLS PCB cpl.	COMANDO LOCALE cpl.
DL1/DL2	S062000109	LED diode CQY 72 green	Diodo Led CQY 72 verde
DLH1	S062000309	LED diode red	Diodo Led rosso
	S068055309	Power switch	Interruttore rete
	S068056309	Push EKPT 1105 S	Push EKPT 1105 S
IRH1	S068149109	IF Reciver TFMS 5360	Ricevitore IR TFMS 5360
	S071013909	Earphone jack	Presca Jack cuffia
	S071020109	Audio RCA jack left (white)	Presca RCA White audio sx
	S071020119	Audio RCA jack right (red)	Presca RCA red audio dx
	S071020129	Video RCA jack (yellow)	Presca RCA yellow video
	S079049409	Door	Sportello comandi
	S082810409	IR filter	Filtro IR
	S083305009	Power button	Tasto interruttore
	S007817509	Cabinet front (DIAPASON 36)	Mobile parte frontale (DIAPASON 36)
	S007817529	Cabinet front (TRIADE 9203)	Mobile parte frontale (TRIADE 9203)
	S078175809	Back cover	Schienale
	S073170809	Speaker 8 Ohm 80x160	Altoparlante 8 Ohm 80x160
	S073170659	Tweeter	Altoparlante tweeter
	S060336009	CRT 36" 16:9 A86ECT13X01	Cinescopio 36" 16:9 A86ECT13X01
	S067203609	Degauss coil	Bobina smagnetizzazione
	S087124609	Chassis holder	Staffa supporto telaio
	S087124709	Trasversal holder	Fissaggio staffa telaio
	S068134909	Remote control (DIAPASON 36)	Telecomando (DIAPASON 36)
	S068134969	Remote control (TRIADE 9203)	Telecomando (TRIADE 9203)
TRIADE 3403 TRIADE 7103			
TRIADE 8603 STUDIO 709			
	S000844909	MANUALS CONTROLS PCB cpl.	COMANDO LOCALE cpl.
	S068055309	Power switch	Interruttore rete
	S079041509	Door	Sportellino
	S083304209	Power button	Tasto interruttore rete
	S091041709	Spring (power button)	Molla tasto interruttore
	S000834909	IR RECIVER cpl.	MODULO RICEVITORE IR cpl.
	S068149109	IR reciver TFMS 5360	Ricevitore IR TFMS 5360
	S007817119	BOX SUBWOOFER cpl. (3403/8603)	BOX SUBWOOFER cpl. (3403/8603)
	S073172109	Woofer 2x8 Ohm	Altoparlante woofer 2x8 Ohm
	S007867109	Cabinet front (TRIADE 3403/8603)	Mobile frontale (TRIADE 3403/8603)
	S007865329	Cabinet front (TRIADE 7103)	Mobile frontale (TRIADE 7103)
	S007865119	Cabinet front (Studio 709)	Mobile frontale (STUDIO 709)
	S078171009	Cabinet (TRIADE 3403/8603)	Mobile (TRIADE 3403/8603)
	S078150809	Cabinet (TRIADE 7103/STUDIO 709)	Mobile (TRIADE 7103/STUDIO 709)
	S082041609	Cabinet fuss (STUDIO 709)	Piede mobile (STUDIO 709)
	S008014169	Back cover	Schienale
	S079471009	Front glass (TRIADE 3403/8603)	Vetro (TRIADE 3403/8603)
	S079453209	Front glass (TRIADE 7103)	Vetro (TRIADE 7103)
	S082808709	Glass holder right	Fermavetro dx.

CHASSIS «PROFESSIONAL 4900»

SPARE PARTS LIST - LISTA PARTI DI RICAMBIO

Pos.	Cod.	Description	Descrizione	Price Lit.
	S000554949	FRONT-END PCB 4900 BG cpl.	BASE FRONT-END 4900 BG cpl.	
CR7/CR8	S012027009	Ceramic condensator NPO 27pF	Cond. ceramico NP0 27pF	
RR105/RR109	S047010009	Fuse resistor 10 Ohm	Resistenza fusibile 10 Ohm	
ZR1	S061961079	Zener diode ZPD 3,6	Diodo zener ZPD 3,6	
ZR2	S061961409	Zener diode ZPD 5,1	Diodo zener ZPD 5,1	
ZR3	S061961509	Zener diode ZPD 5,6	Diodo zener ZPD 5,6	
ZS1	S061961959	Zener diode ZPD 10	Diodo zener ZPD 10	
TR1	S062520349	Transistor BC640	Transistor BC640	
ICR3	S063074009	IC 74HCT241	IC 74HCT241	
ICS3	S063108309	IC TDA1521	IC TDA1521	
ICS4	S063128229	IC TDA2822M	IC TDA2822M	
ICS1	S063184159	IC TDA8415	IC TDA8415	
ICS2	S063184219	IC TDA8421	IC TDA8421	
ICR2	S063184879	IC PCA84C841-SEI04	IC PCA84C841-SEI04	
ICR1	S063185719	IC ST24C02	IC ST24C02	
QR1/QS1	S066900409	Quarz 10 MHz	Quarzo 10 MHz	
	S069027009	Front-end FQ816-IF-PLL BG	Front-end FQ816-IF-PLL BG	
AP1/AP2	S071013409	External speaker connector	Pres a altop. supplementare	
	S082749909	Holder Front-end PCB	Supporto sfondo BFE 4900	
	S000564939	POWER PCB 4900 16:9 cpl.	BASE POWER 4900 16:9 cpl.	
CP3/CP4/CP12/				
CP17	S017222009	Condensator 2,2 nF 1000 V	Condensatore 2,2nF 1000 V	
CP18	S020222009	Condensator 2,2 nF 4000 V	Condensatore 2,2 nF 4000 V	
CP6	S029621209	Condensator 1,2 nF 1%	Condensatore 1,2 nF 1%	
CP1	S030242209	Condensator 220 nF 250 VAC	Condensatore 220 nF 250 VAC	
CP11	S040781509	Elco 150 uF 385 V	Condensatore elettr.150uF 385 V	
RP2	S045411009	Resistor 110 KOhm 2%	Resistenza 110 KOhm 2%	
RL36	S047004709	Fuse resistor 4,7 Ohm	Resistenza fusibile 4,7 Ohm	
RP1	S053051009	Resistor 1 MOhm VR37	Resistenza 1 MOhm VR37	
RP17	S053210709	Resistor 4,7 MOhm VR68	Resistenza 4,7 MOhm VR68	
RP16	S055490009	Resistor 220 Ohm 9 W	Resistenza 220 Ohm 9 W	
NTC1	S056590209	NTC resistor 4,7 Ohm	Resistenza 4,7 Ohm NTC	
PTC1	S056592009	Degauss PTC	Resistenza PTC	
DP13/DP15/DL11	S061300509	Diode BYW29/200	Diodo BYW29/200	
DP14	S061302609	Diode BYW95C	Diodo BYW95C	
DL7	S061303209	Diode BYW96D	Diodo BYW96D	
DL6	S061316879	Diode BY228	Diodo BY228	
DL9/DP16	S061401339	Diode BYD33J	Diodo BYD33J	
ZG1	S061962059	Zener diode ZPD13	Diodo zener ZPD13	
ZP1	S061963019	Zener diode ZPD33	Diodo zener ZPD33	
ZL1	S061963109	Zener diode ZPD36	Diodo zener ZPD36	
TL2	S062520349	Transistor BC640	Transistor BC640	
TP1/TL5	S062756109	Transistor S2000AF	Transistor S2000AF	
ICL1	S063162309	IC TEA2029C	IC TEA2029C	
ICP1	S063163509	IC TEA2164	IC TEA2164	
ICL2	S063181409	IC TDA8140	IC TDA8140	
ICG1	S063181459	IC TDA8145	IC TDA8145	
ICF1	S063181709	IC TDA8170	IC TDA8170	

	S082808809	Glass holder left	Fermavetro sx.
	S073170659	Tweeter	Altoparlante tweeter
	S073172209	Speaker 16 Ohm (TRIADE 3403/8603)	Altop. 16 Ohm (TRIADE 3403/8603)
	S073171309	Speaker 8 Ohm (7103/709)	Altop. 8 Ohm (7103/709)
	S060334109	CRT 34" A79ECU33X01	Cinescopio 34" A79ECU33X01
		(TRIADE 3403/8603)	(TRIADE 3403/8603)
	S060328109	CRT 28" A66ECY13X31	Cinescopio 28" A66ECY13X31
		(TRIADE 7103/STUDIO 709)	(TRIADE 7103/STUDIO 709)
	S067203319	Degauss coil (TRIADE 3403/8603)	Bobina smagn. (TRIADE 3403/8603)
	S067202119	Degauss coil (7103/709)	Bobina smagn. (7103/709)
	S068134969	Remote control	Telecomando

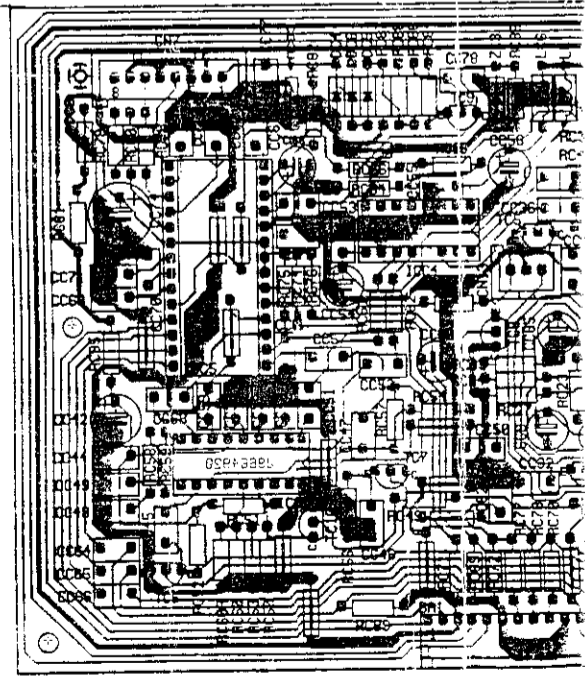
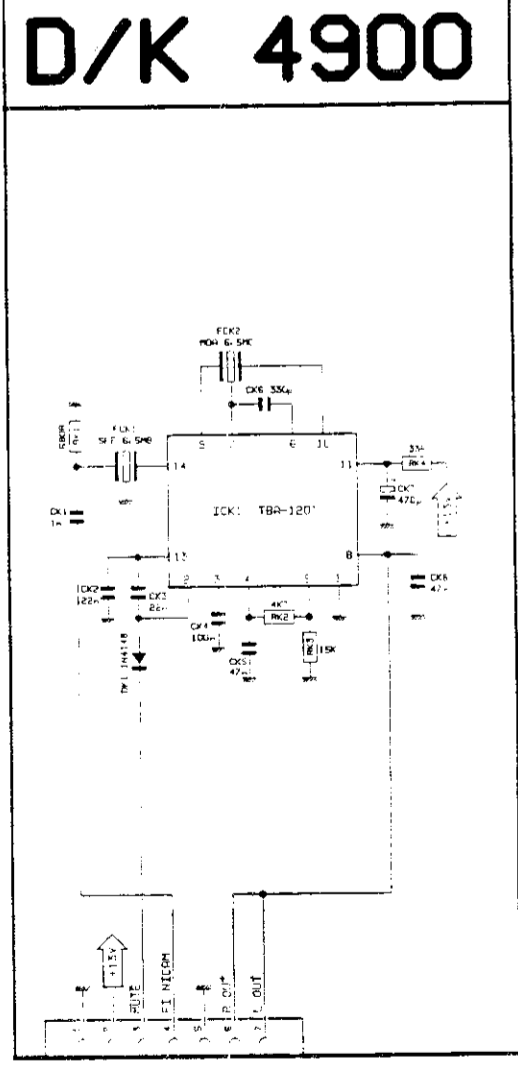
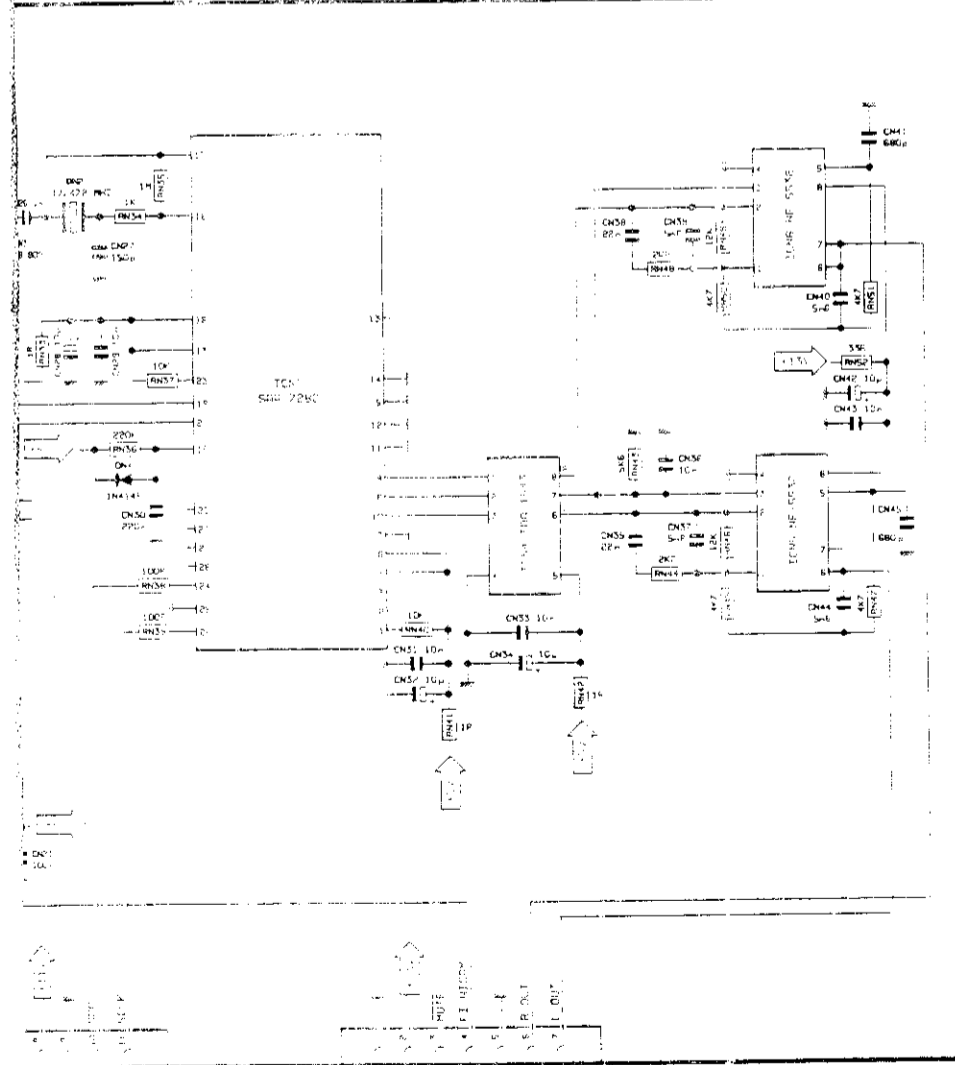
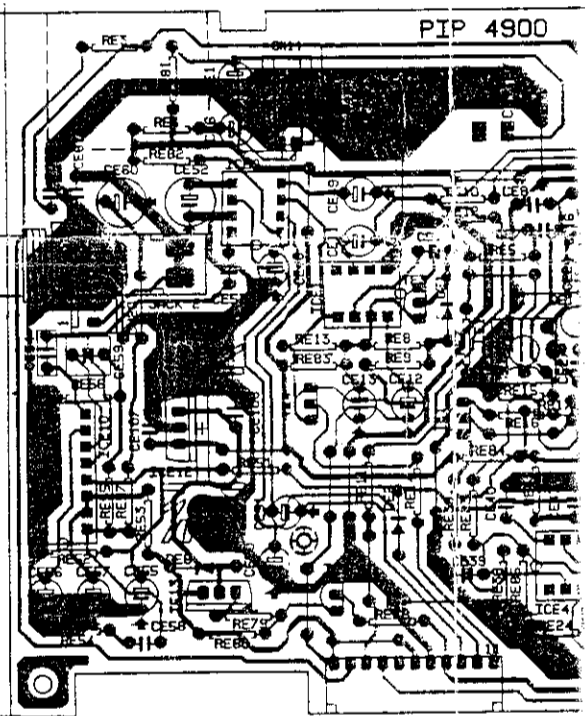
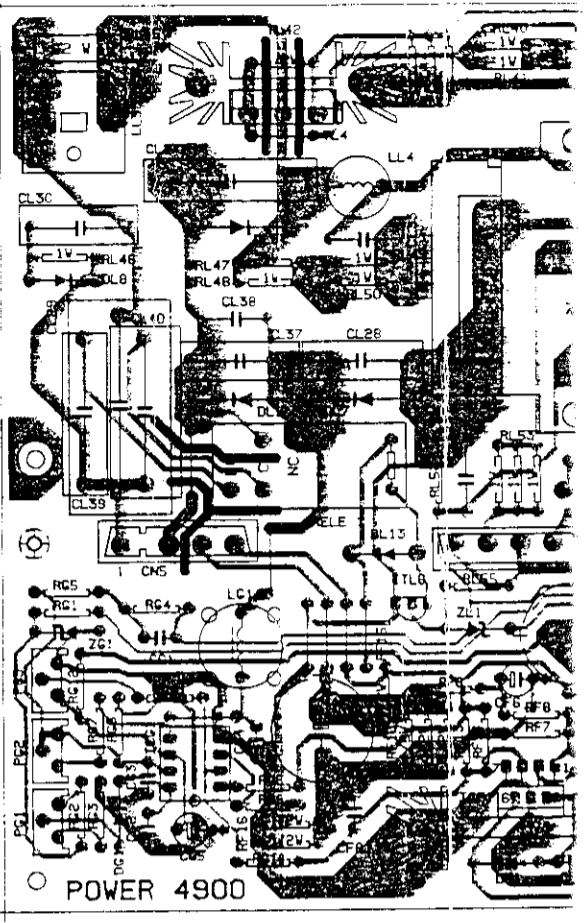
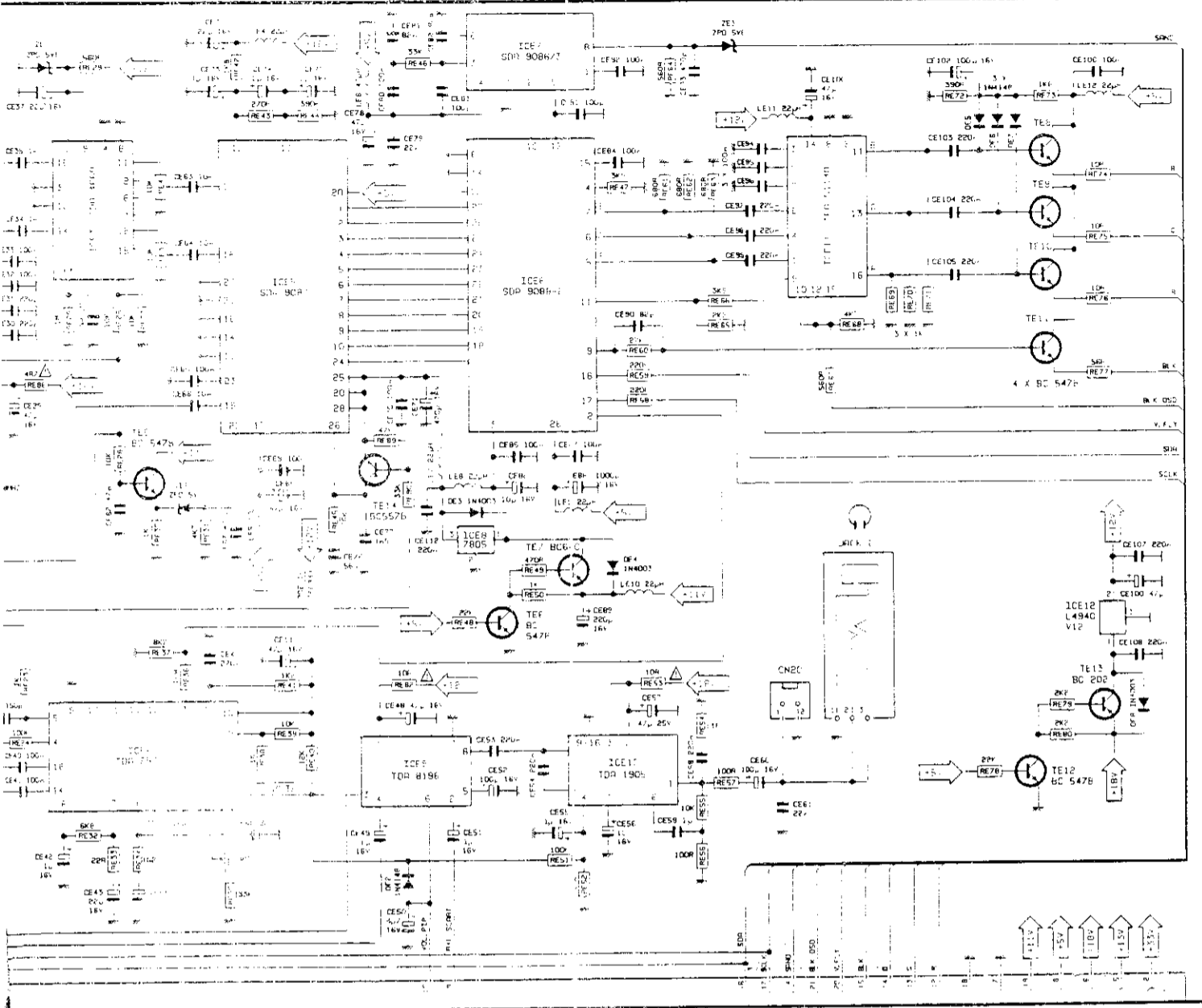

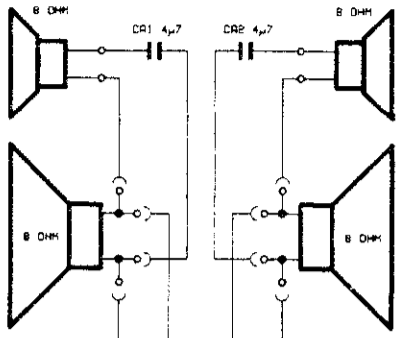

BFE 4900

BASE FRONT END
CHASSIS FRONT END
800055-4900

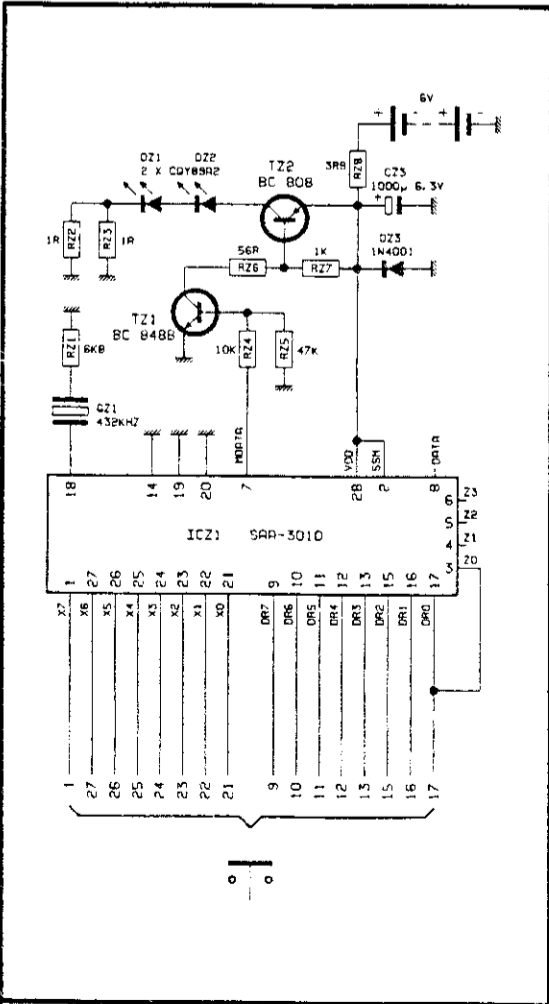
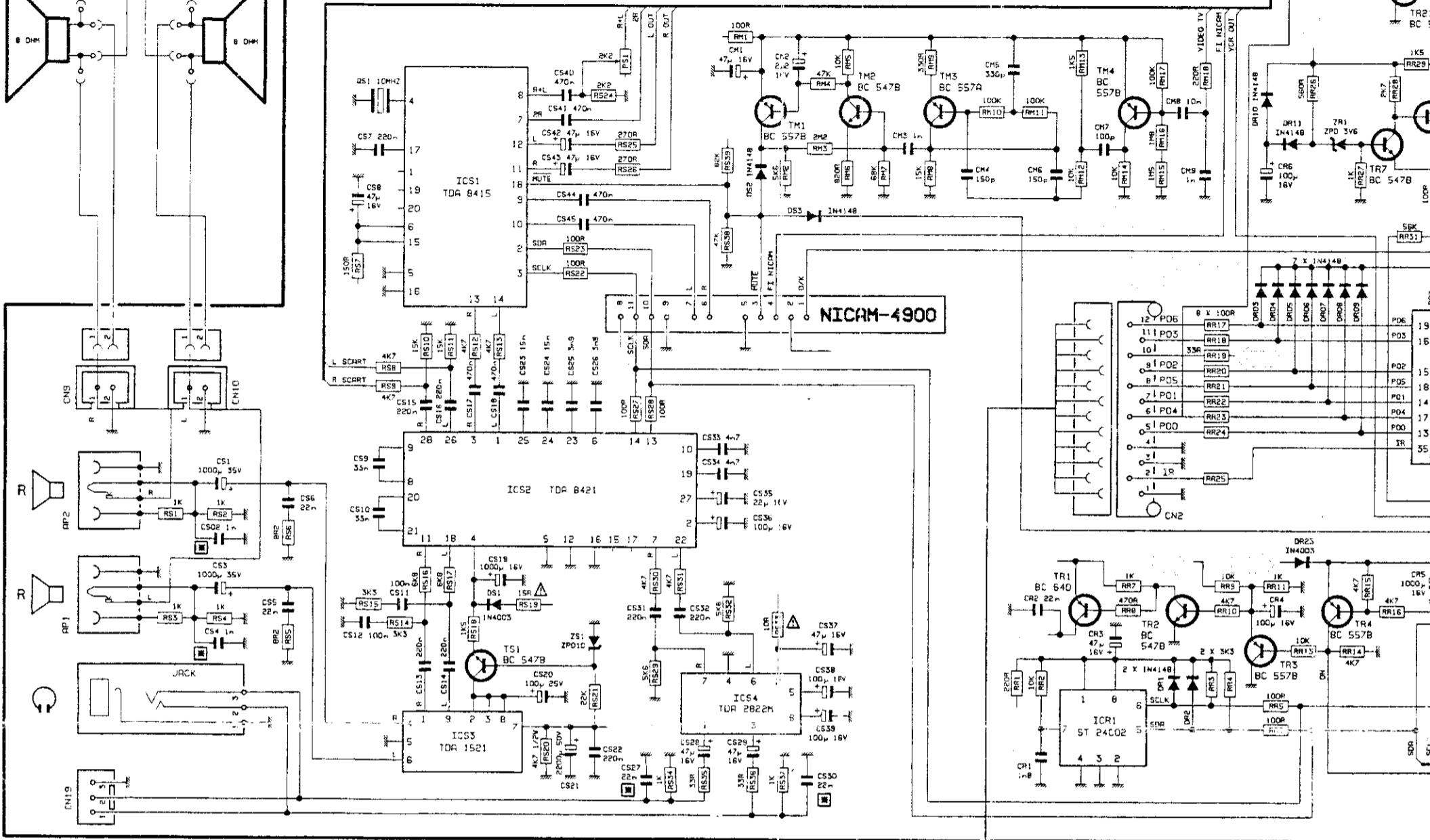

TC 4900

TELECOMANDO INFRA
INFRA-RED GENERATOR
INFRA-ROT-GERBER

TASTO	BUTTON	TASTEN
1	21-16	NICAM D/K
2	21-15	TV
3	21-13	AV
4	21-12	SELE
5	21-11	NORM
6	21-10	PIP
7	21-8	TV
8	22-17	AV
9	22-16	SELE
0	21-17	NORM
+	25-17	PIP
- LIST	25-16	TV
☐	22-9	AV
R	24-10	SELE
M	26-9	NORM
<	27-16	PIP
>	27-17	TV
PG+	22-15	AV
IE	1-12	SELE
P/F PG-	22-13	NORM
⊙ SUB	26-15	PIP
? PK	26-12	TV
⊙ MIX	26-10	PIP
STOP	26-16	TV

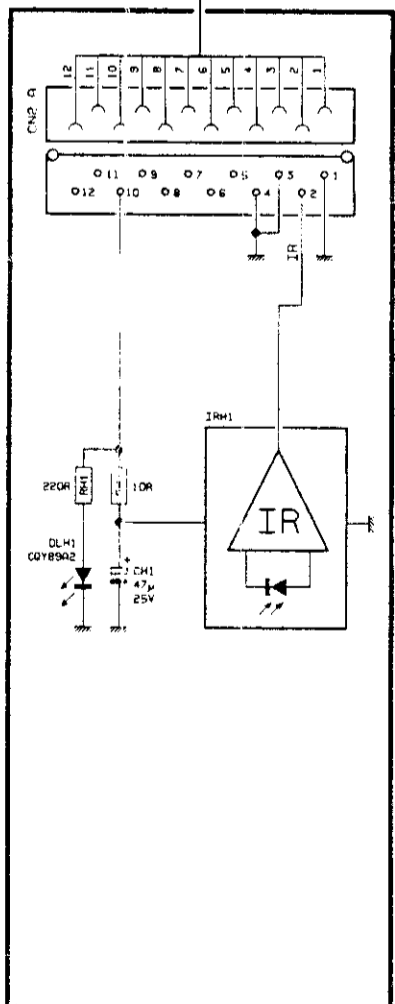

IR 4900

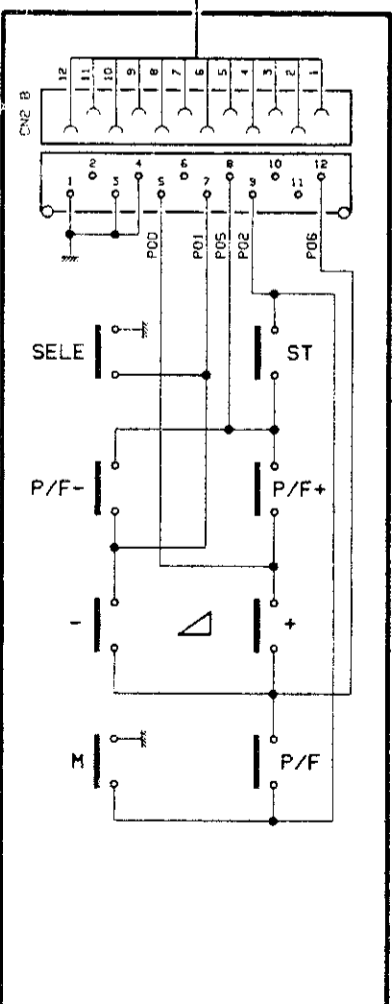

CL 4900

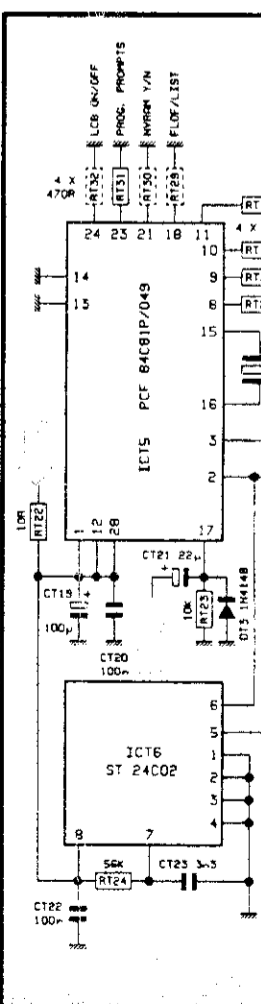

TLV

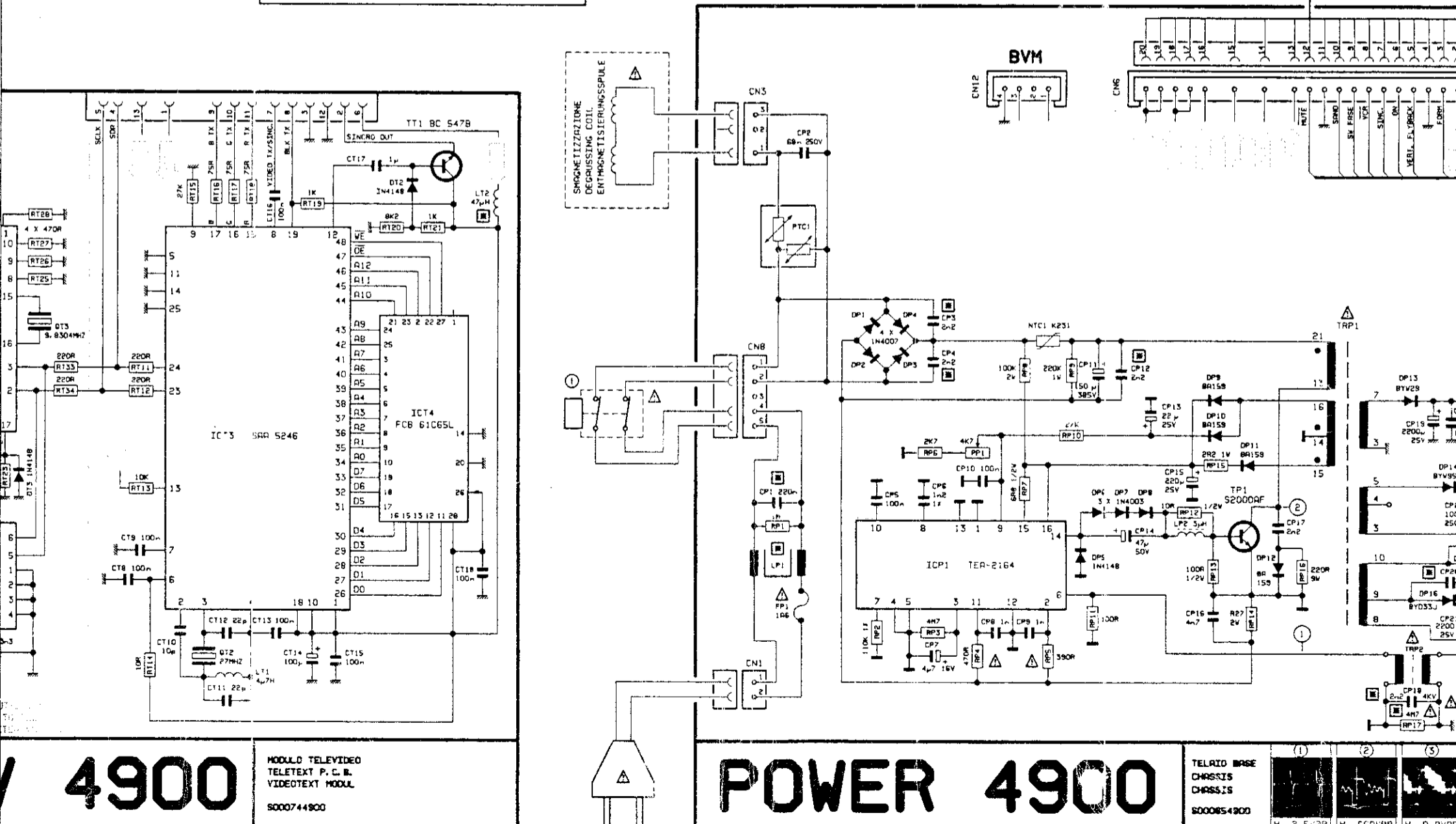
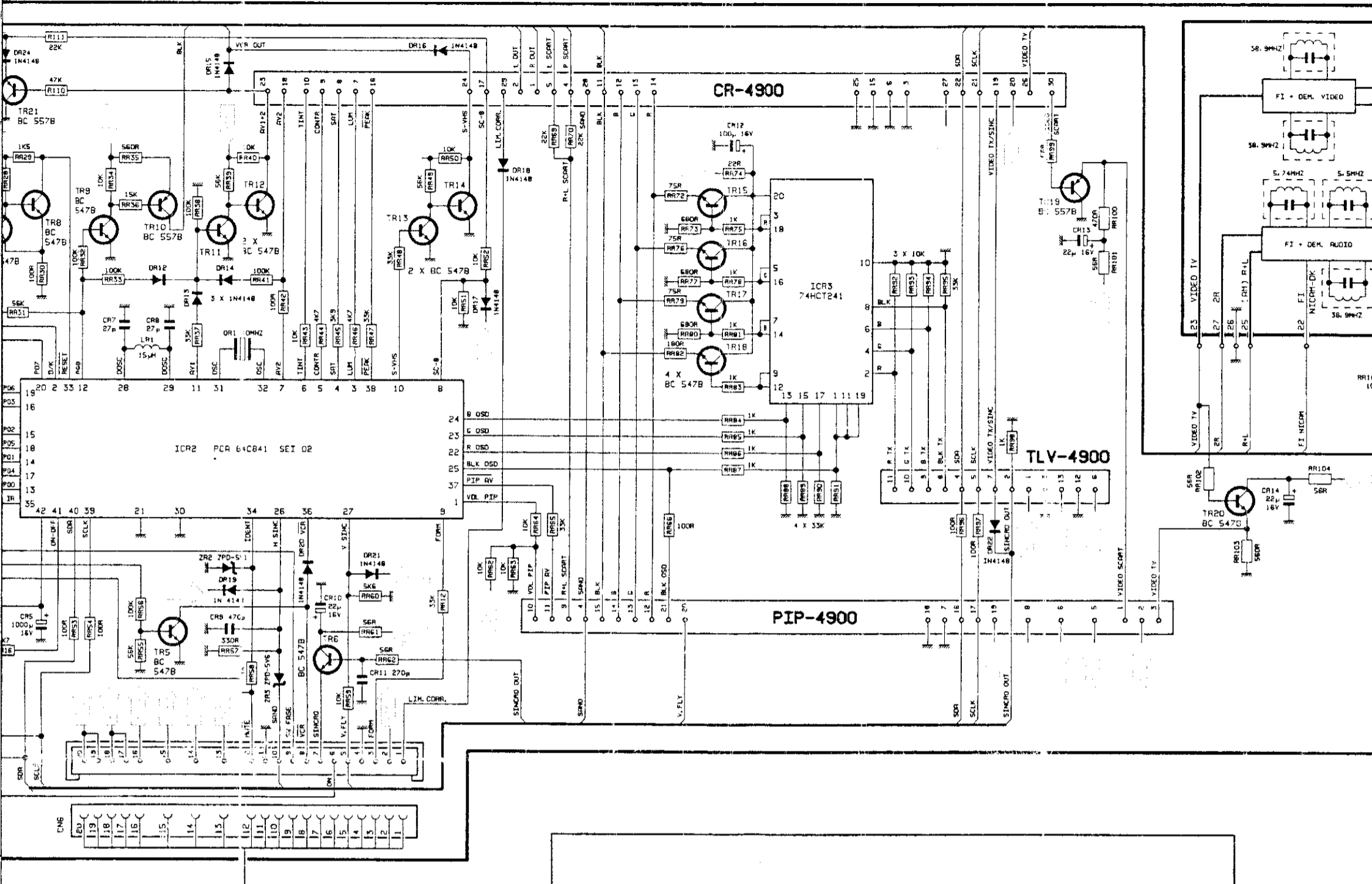

4900

MODULO TELEVIDEO
TELETEXT P. C. B.
VIDEOTEXT MODUL
8000744900

POWER 4900

TELEVIDEO BASE
CHASSIS
8000654900

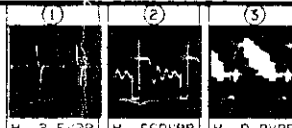

FQ816

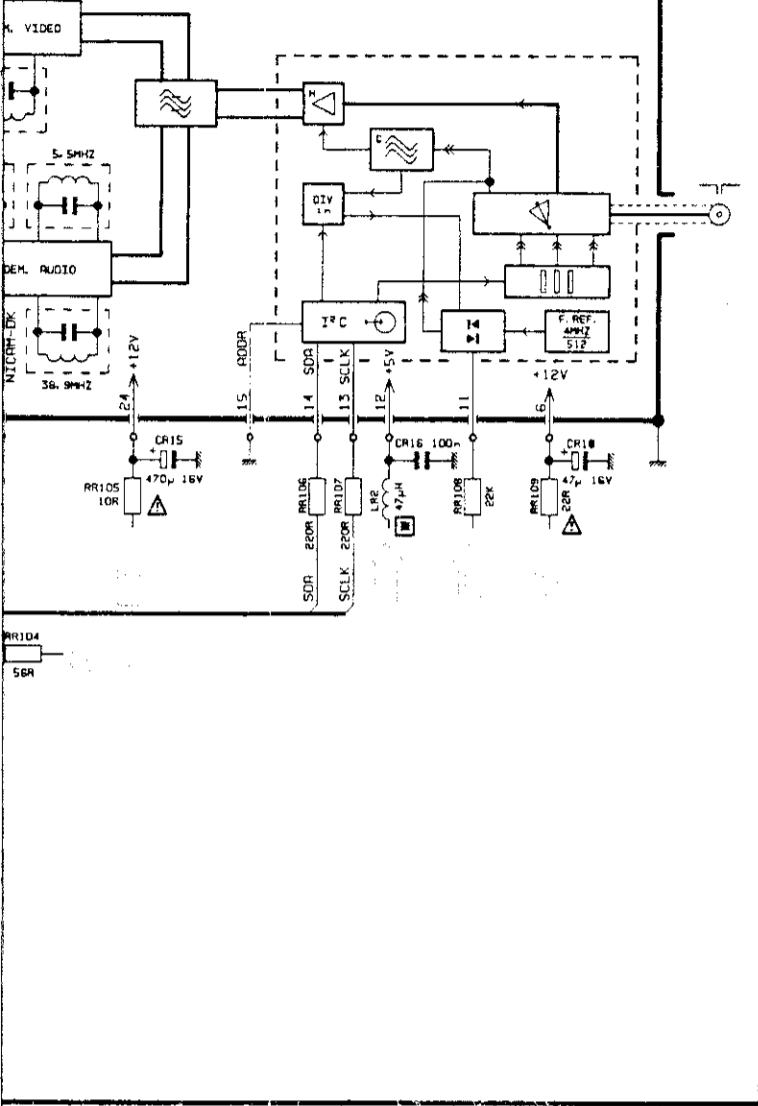

CR-4920

MODELLO CRORA
 COLOR P. C. B.
 1988 MODUL
 8000664920

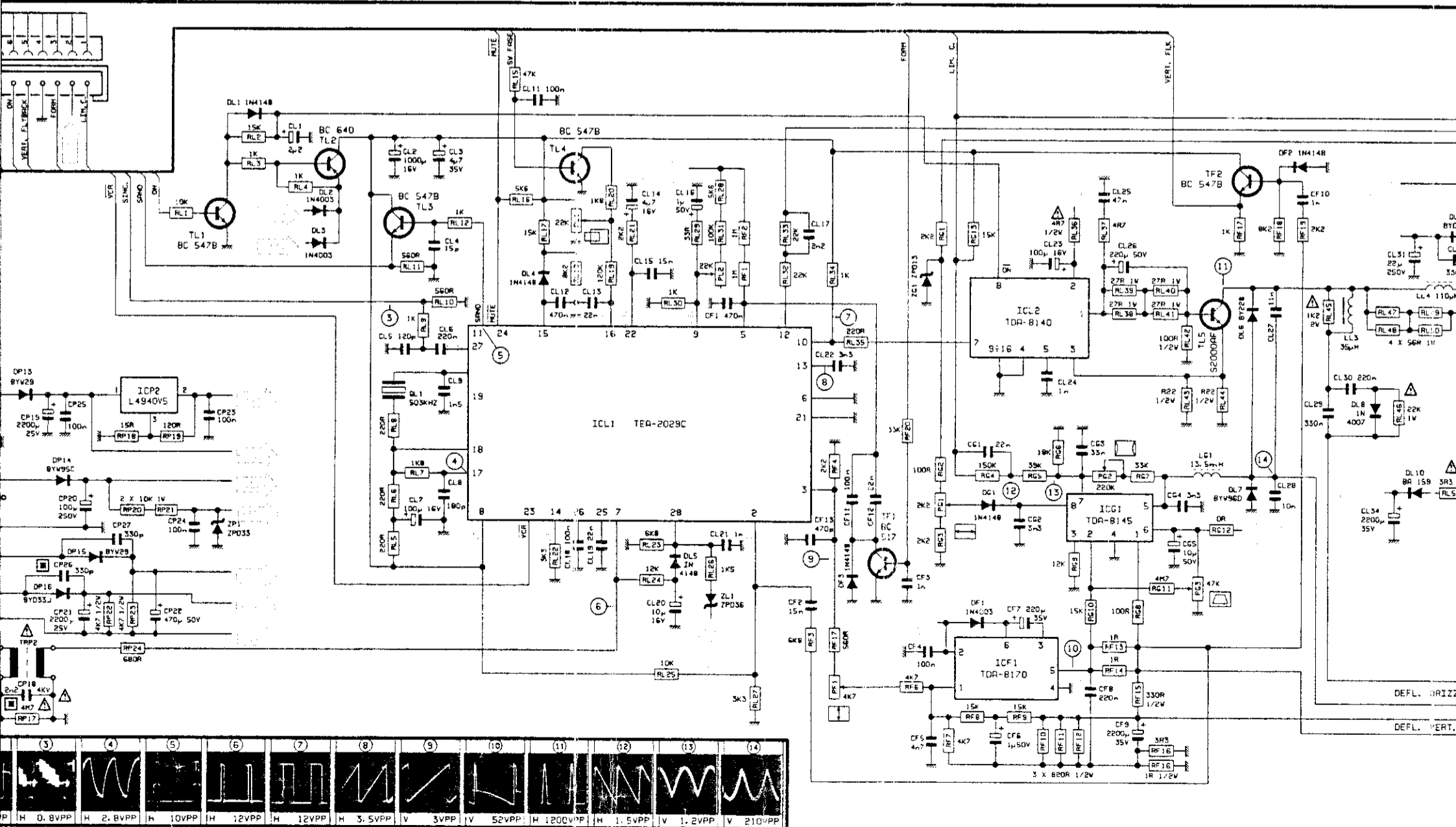
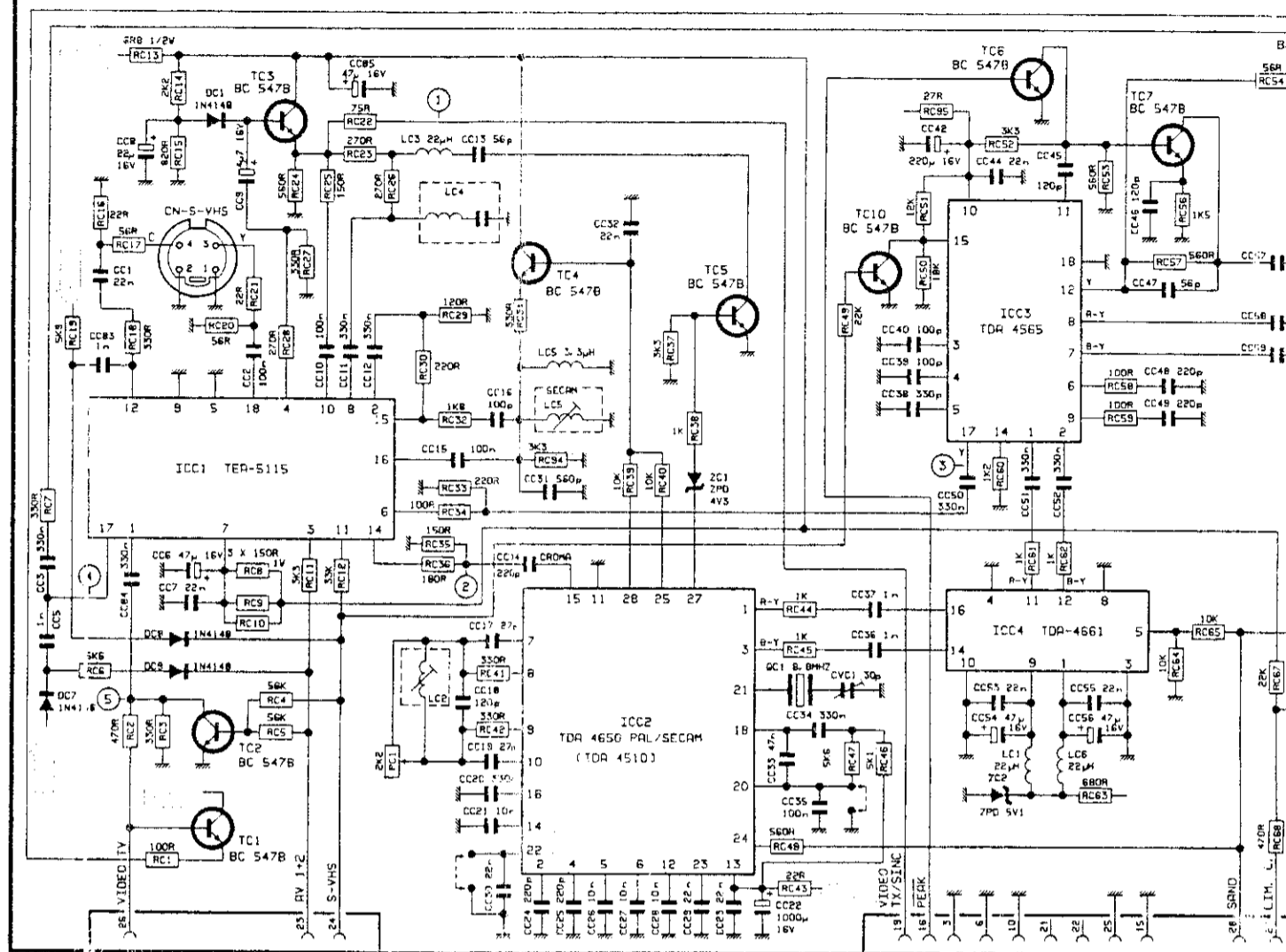

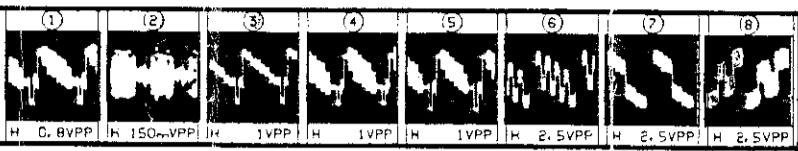

SC-492

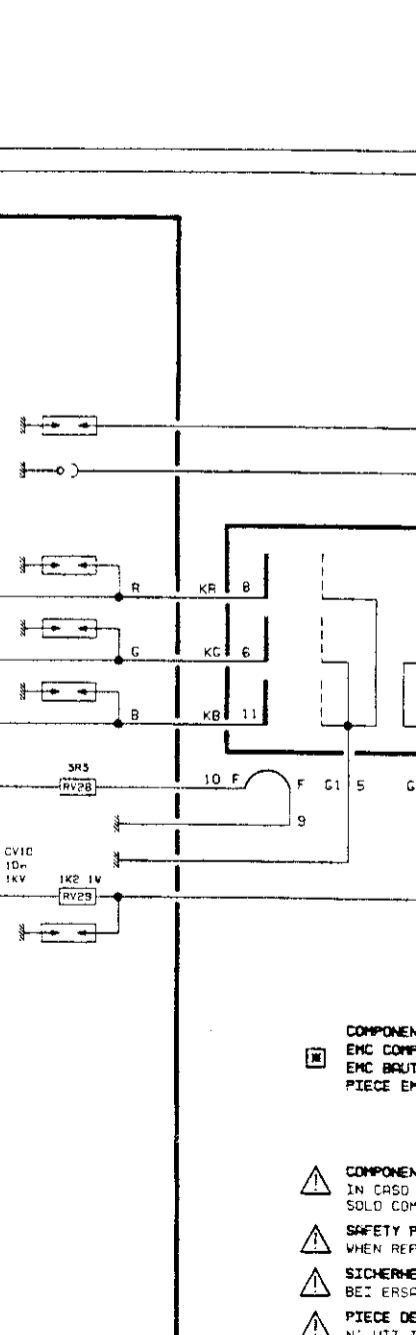
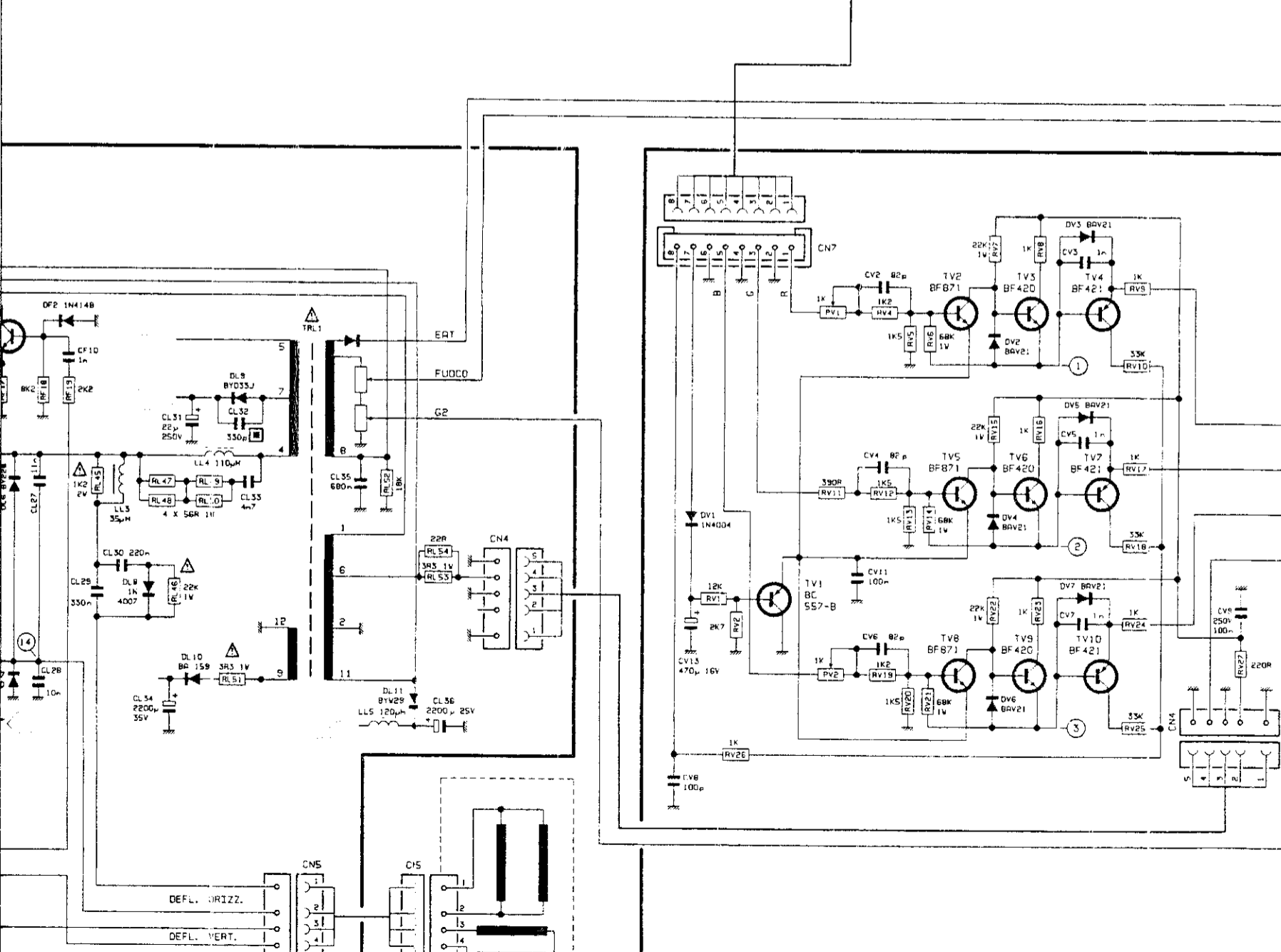
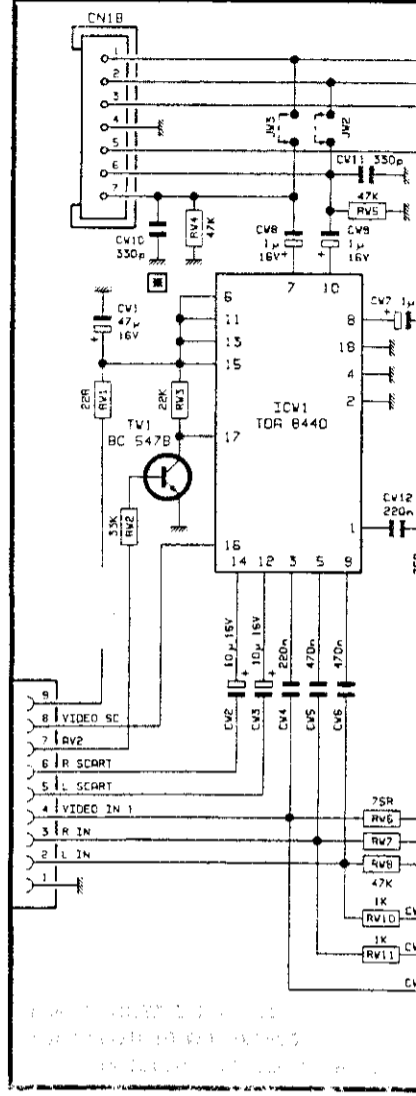
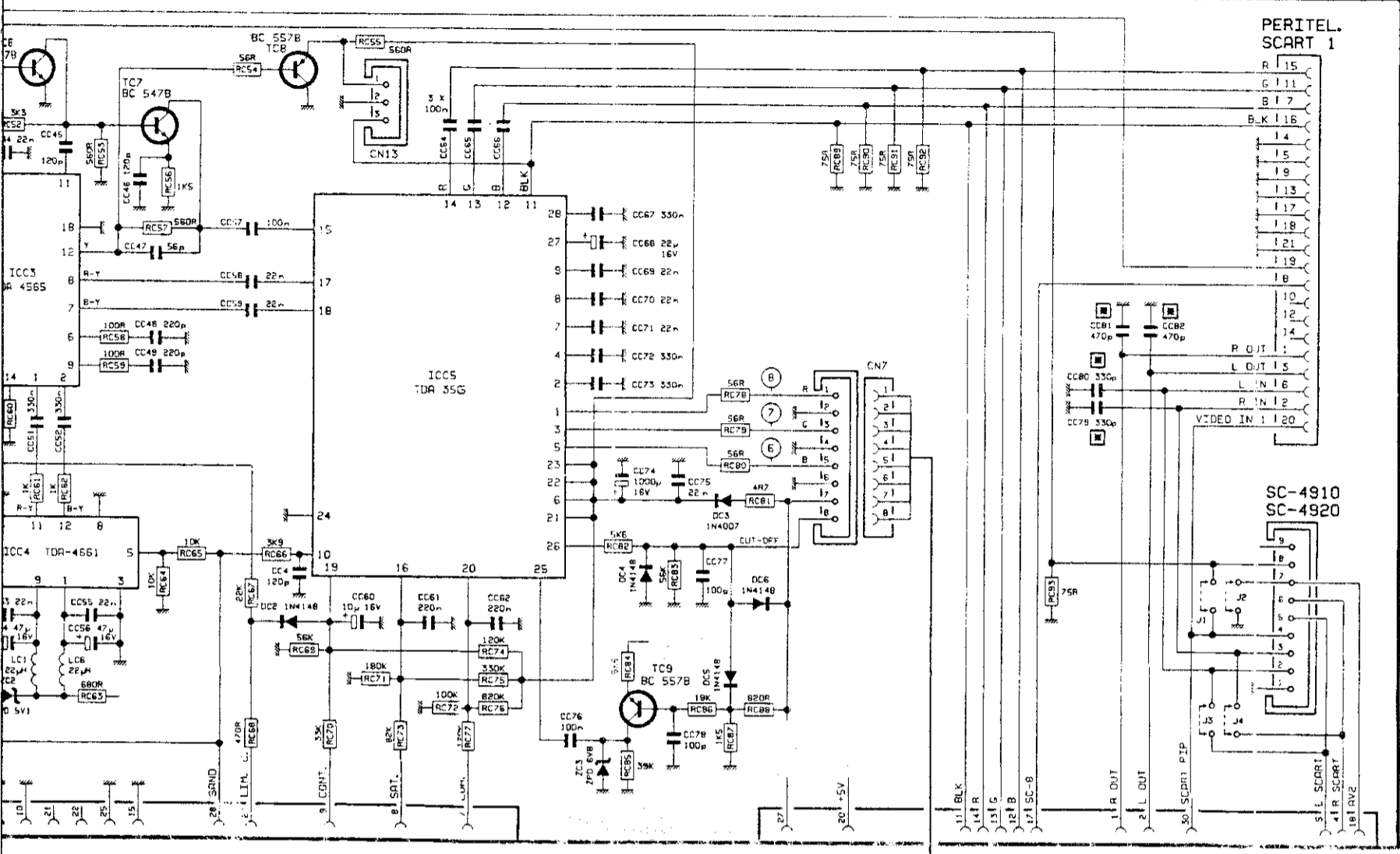

CI-4620

ZOCOLO CINESCOPIO
CRT CONN.
BILDORHPL.
S000674620

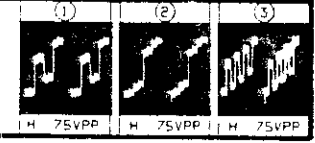

- COMPONENTI IN CASO DI ERRORE NON SODDISFACENTI
- SAFETY PRECAUTIONS: WHEN REPAIRING, BE CAREFUL TO REMOVE THE PROTECTIVE COVER AND TO USE THE APPROPRIATE SAFETY PRECAUTIONS.
- SICHERHEIT: BEI REPARATUR ARBEITEN DIE SICHERHEITSSCHUTZHAUBE ENTFERNEN UND DIE GEBÜHRENDEN SICHERHEITSPRECAUTIONS NUTZEN.
- PIECE DE RECHANGE: EN CAS DE MAUVAIS FONCTIONNEMENT, NE PAS OUBLIER D'ENLEVER LA COUVERCLE ET D'UTILISER LES PRECAUTIONS D'UTILISATION APPROPRIÉES.
- COMPONENTI UTILIZZARE

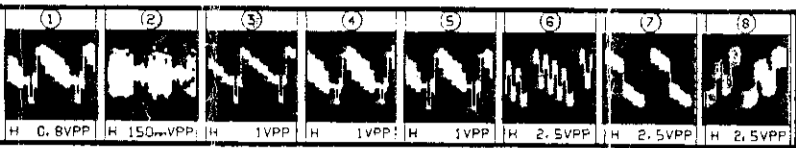

SC-4920

MODULO SCART 2
SCART 2 P.C.B.
SCART 2 MODUL
5000614920

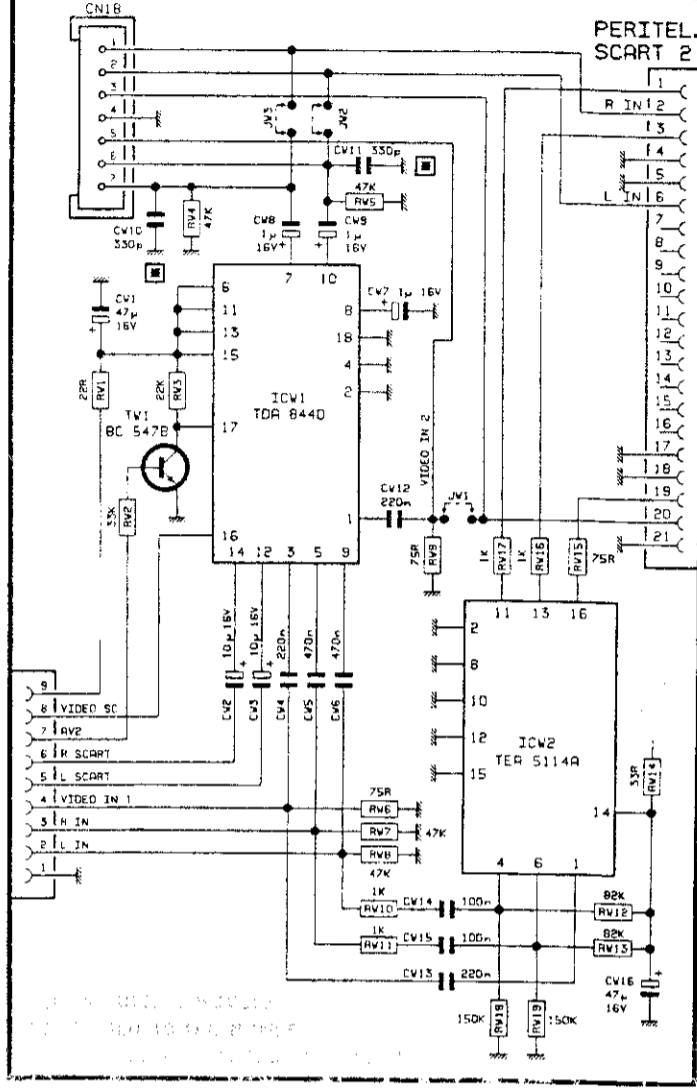
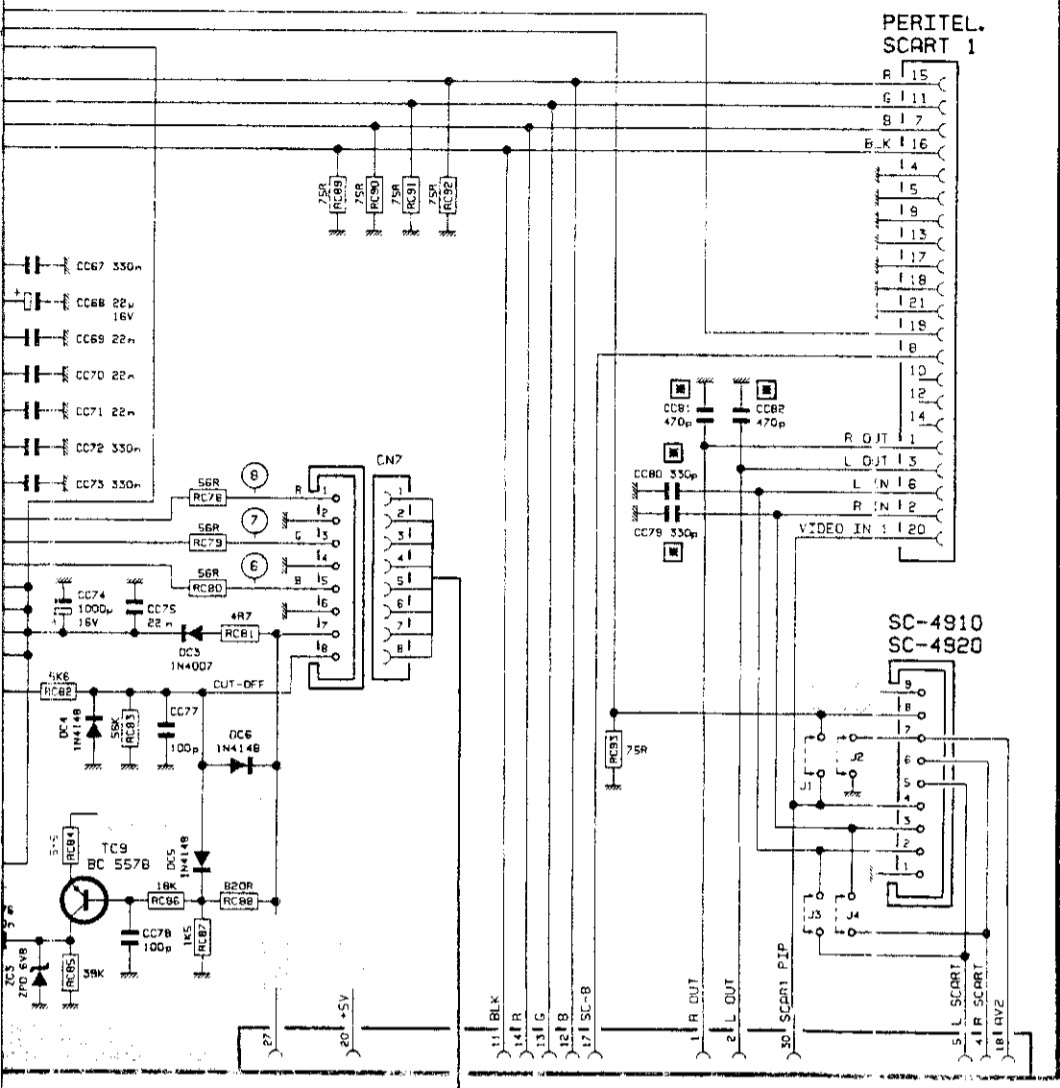

ORION

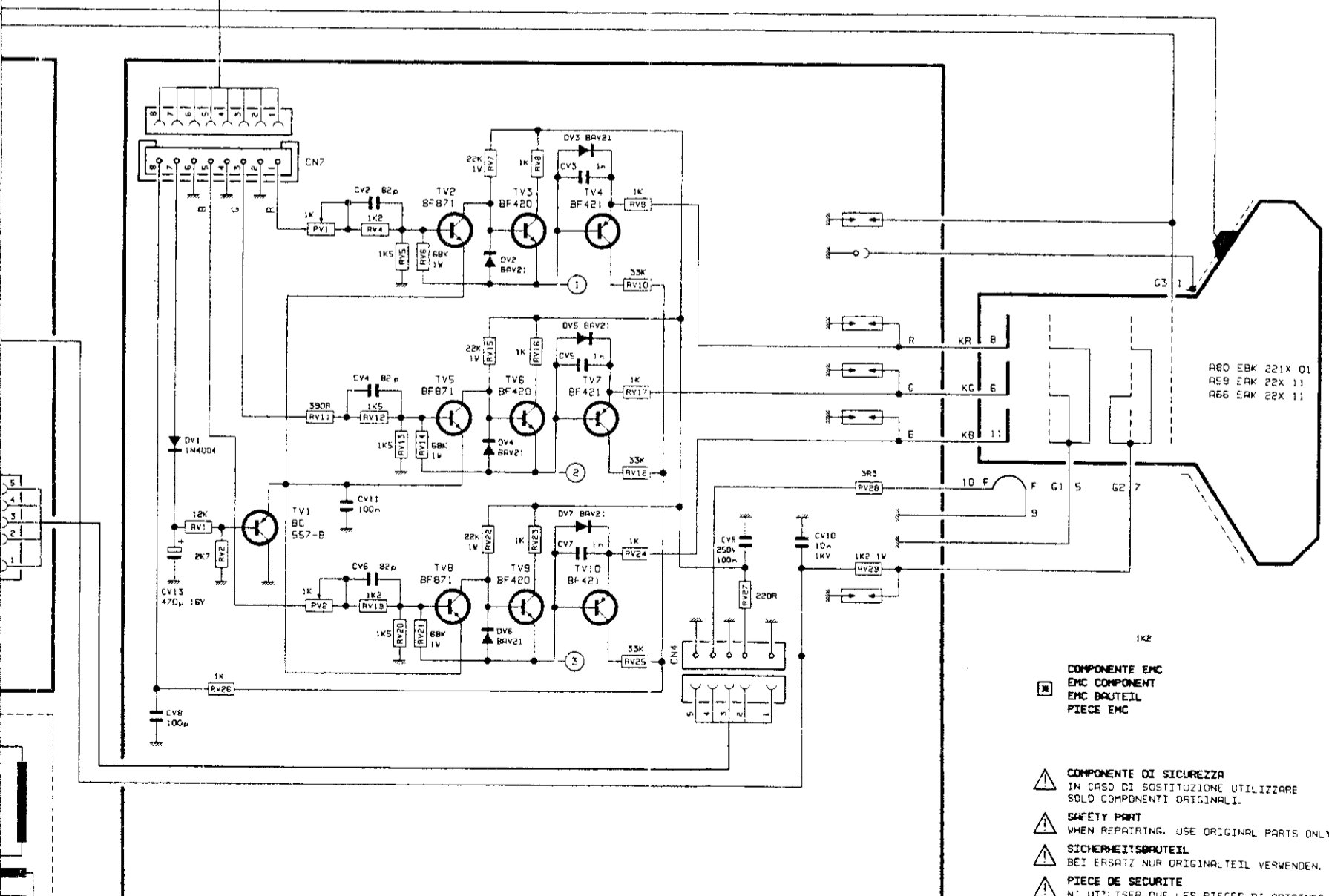

CI-4620

ZOCCHIO CINESCOPIO
CRT CONN.
BILDORHRPL.
5000674620

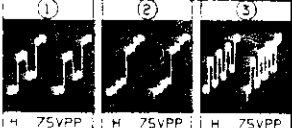

- ☐ COMPONENTE EMC
EMC COMPONENT
EMC BAUTEIL
PIECE EMC
- ⚠ COMPONENTE DI SICUREZZA
IN CASO DI SOSTITUZIONE UTILIZZARE
SOLO COMPONENTI ORIGINALI.
- ⚠ SAFETY PART
WHEN REPAIRING, USE ORIGINAL PARTS ONLY.
- ⚠ SICHERHEITSBauteil
BEI ERSATZ NUR ORIGINALTEIL VERWENDEN.
- ⚠ PIECE DE SECURITE
N'UTILISER QUE LES PIECES D'ORIGINES.
- ⚠ COMPONENTE DE SEGURIDAD
UTILIZAR SOLO COMPONENTES ORIGINALES.

CON RISERVA DI MODIFICHE
SUBJECT TO MODIFICATION
ÄNDERUNGEN VORBEHALTEN

Chassis
Professional
4900

TRIADE 34
TRIADE 36
TRIADE 25
TRIADE 28
STUDIO 28

AVVERTENZA IMPORTANTE

La rimozione dello scrinale rende accessibili parti sottoposte a tensioni anche elevate, ogni intervento dovrà perciò essere effettuato esclusivamente da personale specializzato. Prima dell'esecuzione delle regolazioni di seguito descritte l'apparecchio deve essere acceso per una decina di minuti con schermo mediamente illuminato senza segnale in antenna (solo «effetto neve»).

- **Alimentatore**
Regolare la tensione di rete su 220 V, in condizioni di stand-by regolare PP1 per 10,7 V \pm 0,2 V ai capi di CP19.
Regolare quindi, in condizioni di funzionamento con contrasto e luminosità al minimo, PL2 per 13,5 V \pm 0,1 V ai capi di CL36.
- **Regolazione della geometria dell'immagine**
Posizione orizzontale
Regolare PL1 per una corretta posizione orizzontale dell'immagine.
Ampiezza orizzontale
Regolare con PG1 per la corretta ampiezza orizzontale.

- **Correzione Est-Ovest**
Regolare con PG2 (cuscinetti) e PG3 (trapezio) per la migliore geometria dell'immagine.
- **Ampiezza verticale**
Regolare con PF1.
- **Focalizzazione**
Con il contrasto prossimo al massimo regolare per la migliore focalizzazione dell'immagine.
- **Regolazione punto di lavoro del cinescopio**
Regolare contrasto e luminosità al minimo. Misurare la tensione continua dei tre catodi del cinescopio e regolare il regolatore di griglia schermo G2 in modo che la tensione del catodo riscontrato a valore più elevato sia di 175 V.
Inserire in antenna un segnale a «pagina bianca»
Portare luminosità e contrasto prossimi al massimo e regolare PV1 e PV2 in modo che scompaia ogni sfumatura di colore.

IMPORTANT WARNING

When the back panel is removed, high voltage parts are exposed, so any adjustment must be carried out by specialized personnel only, before performing any of the following adjustments, switch on the set for about ten minutes, with average brightness and without the aerial attached («snow effect» only).

- **Power Supply**
Switch on power supply to 220 V.
Under stand-by conditions, adjust PP1 to 10,7 V \pm 0,2 V at CP19 terminals.
With contrast and brightness at the minimum, adjust PL2 to 13,5 V \pm 0,1 V at CL36 terminals.
- **Adjustment of picture**
Horizontal adjustment
Use PL1 for correct adjustment of picture's horizontal position.

- **Picture width**
Use PG1 to adjust picture width.
- **Crosswise Correction**
Use PG2 and PG3 for picture's best geometry.
- **Picture height**
Use PF1 to adjust.
- **Focusing**
Adjust picture focus with the contrast near to maximum.
- **Adjusting picture tube tension**
Set contrast and brightness to the minimum. Measure direct current voltage of the three picture tube cathodes and adjust the G2 screen grid so that the cathode voltage at its highest value is 175 V. Send a «white page» signal to the aerial. Set brightness and contrast to maximum and adjust PV1 and PV2 so that all colour shades disappear.

WICHTIGER HINWEIS

Nach der Entfernung des Rückendeckels des Gerätes werden Teile zugänglich, die auch Hochspannungen besitzen. Infolgedessen darf jede Reparatur ausschließlich durch Fachpersonal durchgeführt werden.

- Vor der Durchführung der nachstehend beschriebenen Einstellungen soll das Gerät ca. 10 Minuten lang eingeschaltet werden, z.zw. mit mässiger Bildschirmbeleuchtung und ohne Antennensignal (lediglich «Schnee-effekt»).
- **Netzzeit**
Die Netzspannung auf 220 V, einstellen. In «Stand-by» PP1 auf 10,7 V \pm 0,2 V an den Enden von CP19 einstellen.
Danach in Betriebszustand - mit Kontrast und Helligkeit auf Mindestwert - PL2 auf 13,5 V \pm 0,1 V an den Enden von CL36 einstellen.
- **Einstellung der Bildgeometrie**
Horizontallage
PL1 für die korrekte Horizontallage des Bildes einstellen.
Horizontalamplitude
Die Einstellung mit PG1 für die einwandfreie Horizontalamplitude vornehmen.

- **Ost-Westkorrektur**
Die Einstellung mit PG2 (Küschchen) und PG3 (Trapez) für eine bessere Bildgeometrie durchführen.
- **Vertikallage**
Die Einstellung mit PF1 durchführen.
- **Fokussierung**
Bei auf den höchsten Maximalwert eingestellten Kontrast die Einstellung für die bestmögliche Bildfokussierung durchführen.
- **Einstellung des Arbeitspunktes der Bildröhre**
Kontrast und Helligkeit auf Mindestwert einstellen. Die Gleichstromspannung der drei Kathoden der Bildröhre messen und die G2-Schirmgittersteuerung so einstellen, dass die höchste Kathodenfestgestellte Spannung 175 V beträgt.
In die Antenne ein Weisses Seite-Signal einschalten. Helligkeit und Kontrast nahezu auf Maximalwert einstellen und PV1 und PV2 so einstellen, dass alle Farbtöne verschwinden.

PIP 4900

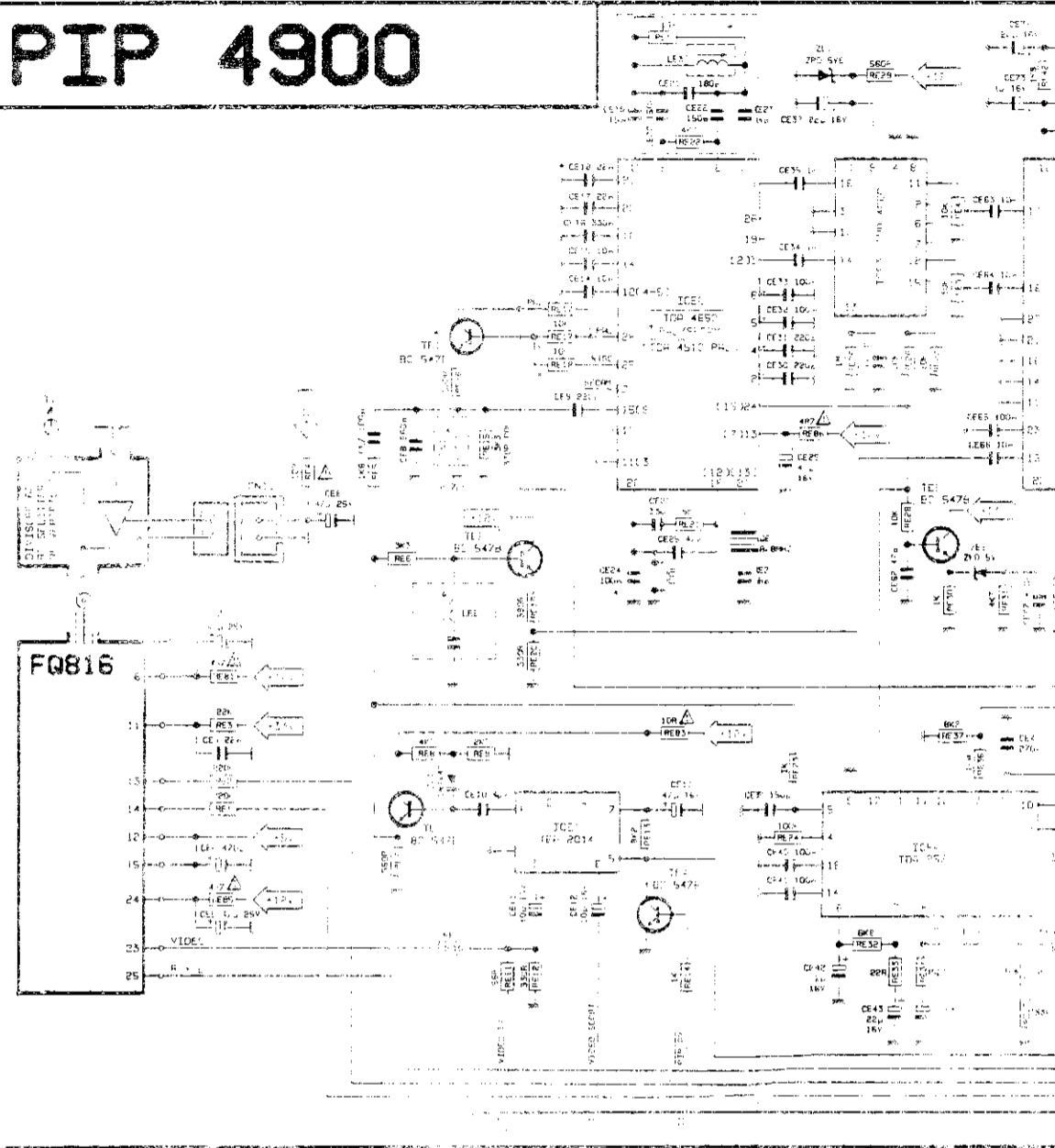

NICAM 4900

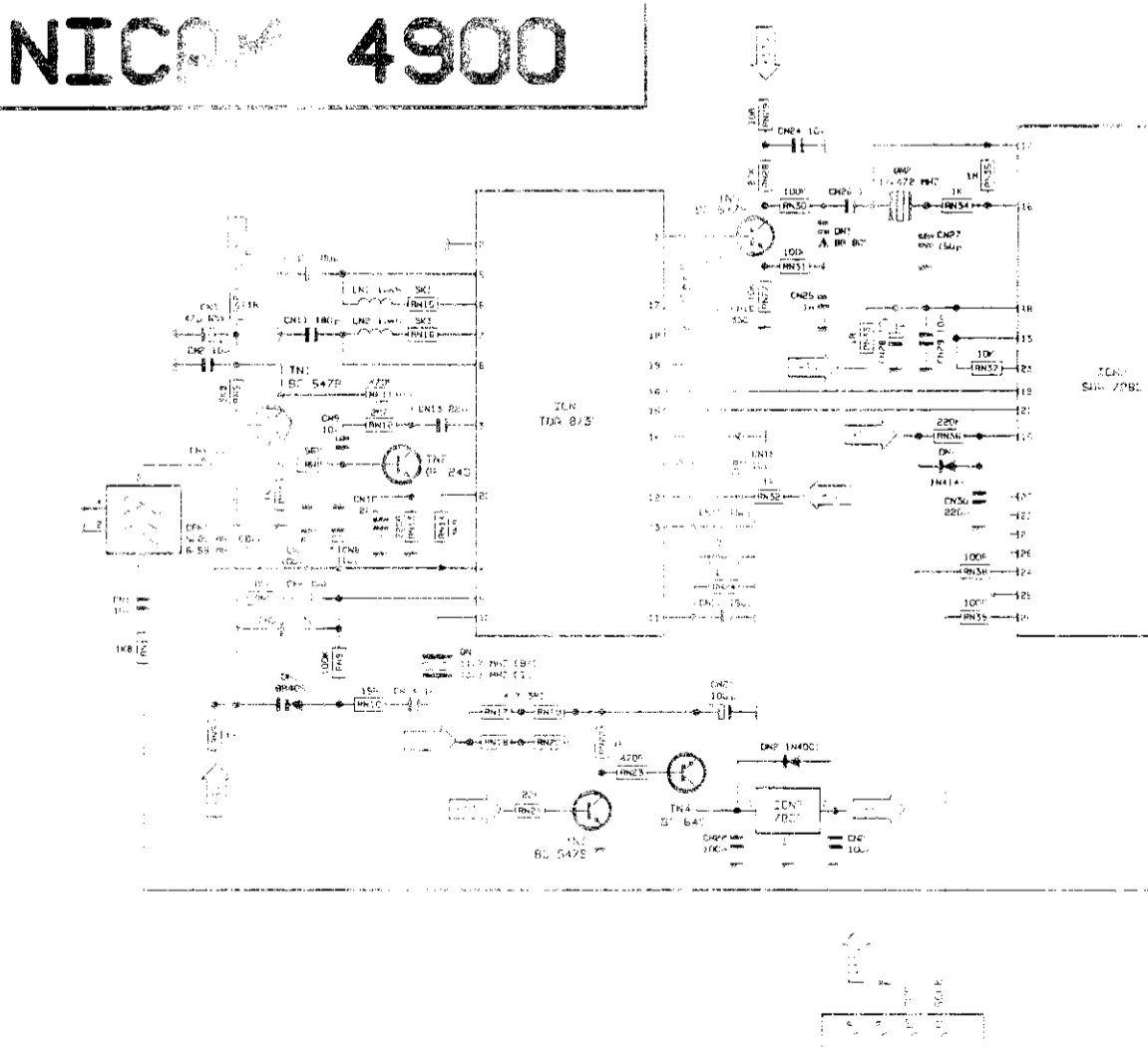

RECOMMANDATIONS IMPORTANTES

Ne jamais enlever le panneau arrière de protection avant d'avoir débranché la fiche du secteur. Cet appareil est conforme aux normes nationales de protection contre les radiations électromagnétiques.

- **Alimentation**
Régler la tension secteur sur 220 V.
En état de veille, régler PP1 sur une tension de 10,7 V \pm 0,2 V aux bornes de CP19.
En condition de fonctionnement avec contraste et luminosité au minimum, régler ensuite PL2 sur une tension de 13,5 V \pm 0,1 V aux bornes de CL36.
- **Réglage de la géométrie de l'image**
Position horizontale
PL1 permet de régler correctement la position horizontale de l'image.
Largeur d'image
PG1 permet de régler correctement la largeur d'image.

- **Correction globale**
PG2 et PG3 permettent d'affiner le réglage de la géométrie de l'image.
- **Hauteur d'image**
Régler avec PF1.
- **Focalisation**
Effectuer la mise au point avec le contraste au maximum.
- **Réglage de la tension du tube**
Régler le contraste et la luminosité au minimum. Mesurer la tension continue des trois cathodes du tube et régler la grille de l'écran avec G2 jusqu'à ce que la crête de la tension de la cathode se stabilise sur 175 V.
Envoyer à l'antenne un signal à «page blanche»
Porter la luminosité et le contraste au maximum puis régler PV1 et PV2 de façon à éliminer toutes les nuances de couleur.

ADVERTENCIA IMPORTANTE

Al quitar la tapa posterior de protección resta accesibles partes con tensiones elevadas y todo trabajo de reparación solo debe ser llevado a cabo por personas especializadas. Antes de efectuar los ajustes y regulaciones descriptas a continuación debe permanecer el aparato en marcha unos diez minutos con la pantalla sin señal, en antena (efecto nieve) y con el control de brillo en su posición media.

- **Alimentación**
Ajustar la tensión de red a 220 V en condiciones de stand-by ajustar mediante PP1 hasta obtener 10,7 V \pm 0,2 V entre los terminales de CP19.
Ajustar PL2 (situando los controles de contraste y brillo al mínimo).
Hasta obtener 13,5 V \pm 0,1 V en los terminales de CL36.
- **Regulación de la geometría de la imagen**
Centrado horizontal
Regular PL1 hasta obtener un correcto centrado de la imagen.
Amplitud horizontal
Regular PG1 hasta obtener una correcta amplitud de la imagen.

- **Corrección est-ouest**
Regular mediante PG2 (cuñil) y PG3 (trapezo) hasta obtener una imagen correcta.
- **Altura de la imagen**
Regular mediante PF1 hasta obtener una altura correcta.
- **Foco**
Con el contraste casi al máximo ajustar el potenciómetro de foco hasta la máxima focalización de la imagen.
- **Ajuste del punto de trabajo del tubo de imagen**
Regular el contraste y el brillo al mínimo. Medir la tensión continua de los tres cátodos del tubo de imagen y ajustar el potenciómetro de G2 de manera que la tensión del cátodo más elevada sea de 175 V.
Conectar a la toma de antena una señal de un generador modulado, para obtener una «Pantalla blanca»
Regular el brillo y el contraste, casi al máximo y regular PV1 y PV2 hasta que desaparezca todo resto de color.

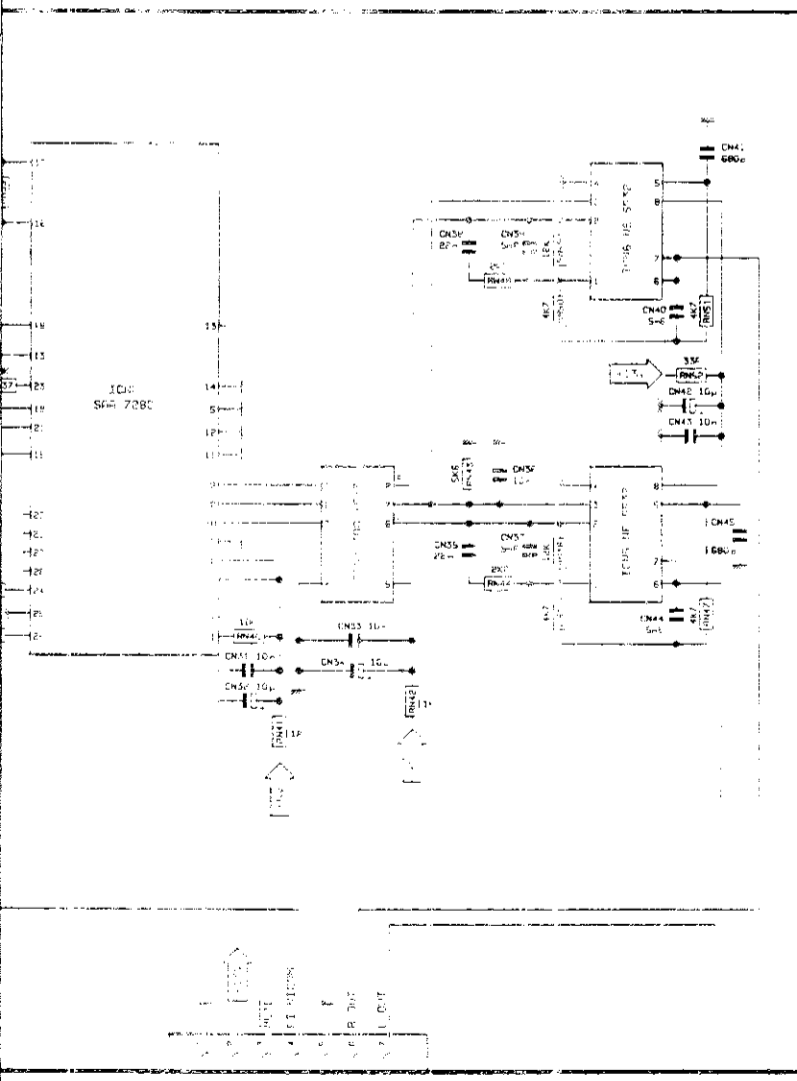
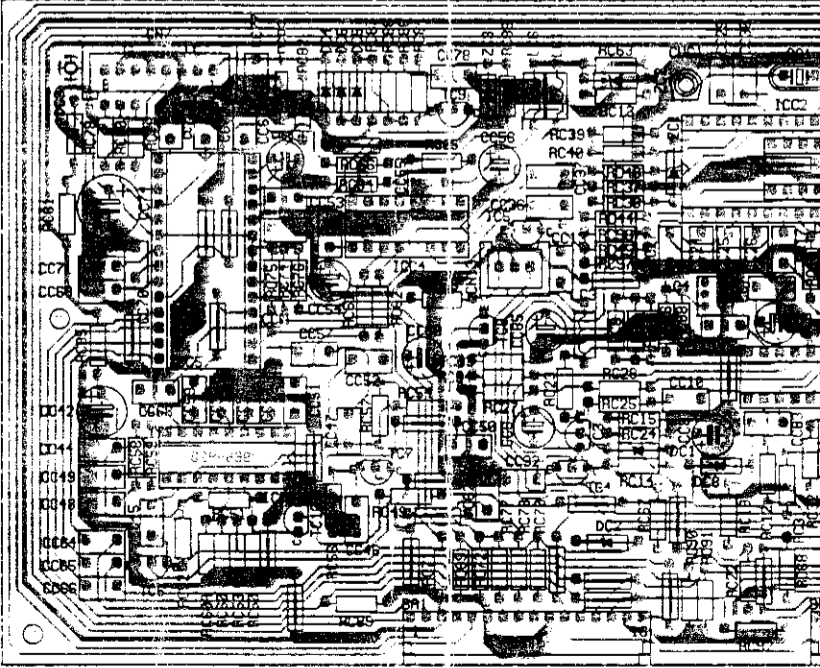
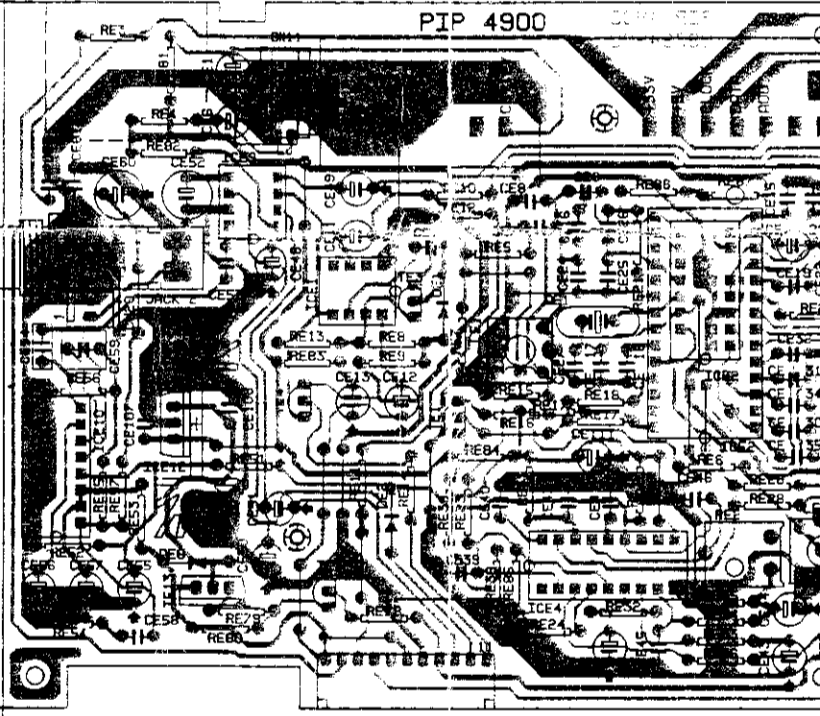
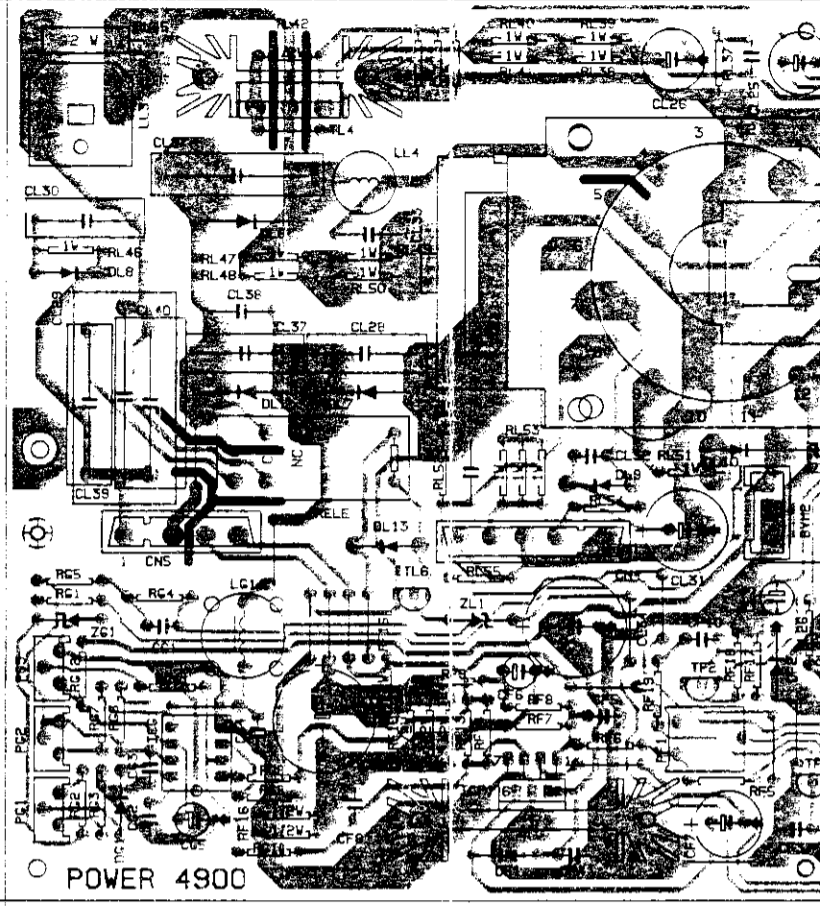
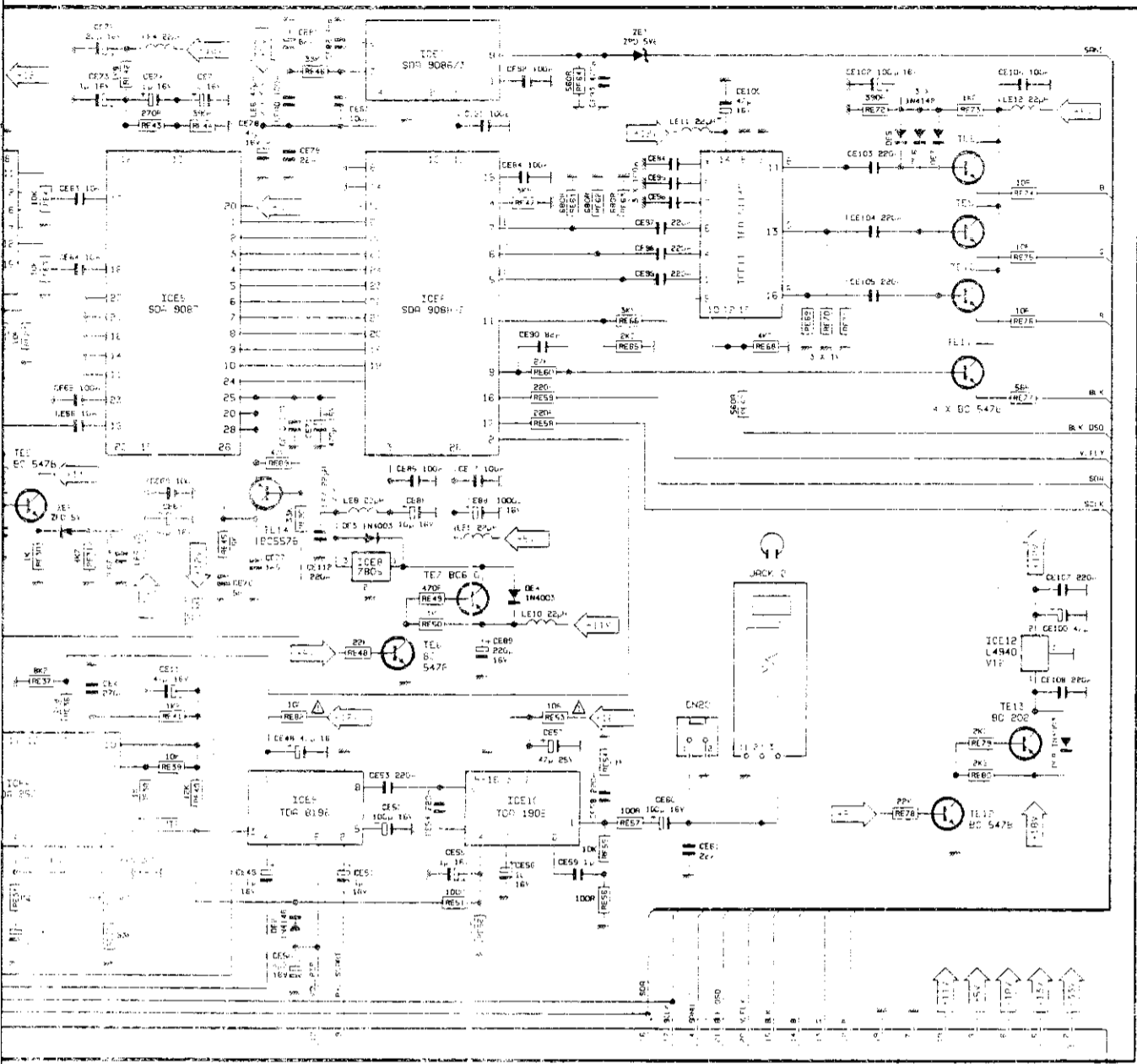

D/K 4900

