

Service Manual

COLOR TELEVISION RECEIVER



PAL / SECAM

ORION

COLOR 5588 VT

COLOR 553

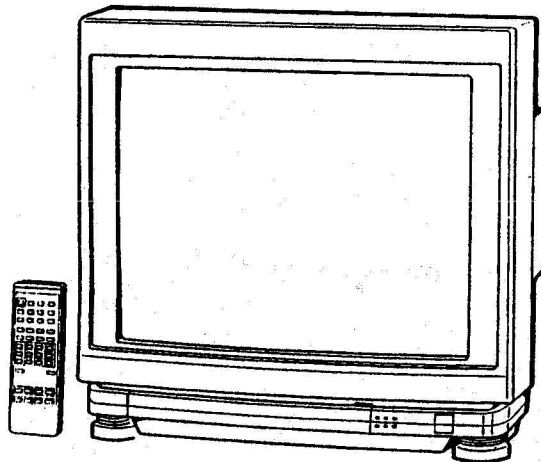

CONTENTS

	PAGE
SPECIFICATIONS	1
MAJOR COMPONENTS LOCATION GUIDE	2
ALIGNMENT INSTRUCTIONS	3 , 4
BLOCK DIAGRAMS	5 , 6
MAIN P.C.BOARD	7
CRT/POWER/CONTROL/LED/HEADPHONE JACK/POWER SWITCH/T' TEXT P.C. BOARDS ...	8
CHASSIS SCHEMATIC DIAGRAMS	9~13
MECHANICAL EXPLODED VIEW	14
MECHANICAL REPLACEMENT PARTS LIST	15
ELECTRICAL REPLACEMENT PARTS LIST	16~18
INTERCHANGEABLE PARTS LIST	19

SPECIFICATIONS

PICTURE SIZE	21 inch
SYSTEM	PAL/SECAM
FREQUENCY RANGE VHF(L)	2 - 4, X - S2 ch, 47 - 118 MHz
VHF(H)	S3 - S10, 5 - 12, S11 - S20 ch
UHF	118 - 300 MHz
UHF	21 - 69 ch, 470 - 862 MHz
MAXIMUM SENSITIVITY VHF	20 dB
UHF	25 dB
INTERMEDIATE FREQUENCY:	
Picture IF Carrier Frequency	38.9 MHz
Color Sub Carrier Frequency	34.47 MHz
Sound IF Carrier Frequency	33.4 MHz
SOUND INTERMEDIATE FREQUENCY	5.5 MHz
MAXIMUM OUTPUT POWER	5.0 W
10% THD OUTPUT POWER	4.0 W
SPEAKER	4 ohm
POWER SOURCE	AC 220V

IMPORTANT

*FOR SERVICE WORK ALWAYS USE MAINS ISOLATING TRANSFORMER, CHASSIS IS LIVE.
(IRRESPECTIVE OF POLARITY OF MAINS PLUG.)

*IN CASE OF REMOVING PCB OR SOMETHING, AFTER UNFASTENING THE WIRE OR
CHANGING THE WIRE POSITION, IT IS IMPORTANT TO PUT THE FASTENING OF
WIRE AND THE POSITION OF WIRE AS IT WAS.
BECAUSE, PICTURE DISTORTION OR SOMETHING MAY APPEAR ON THE DISPLAY.
SO, BE SURE TO CONFIRM THE FASTENING AND POSITION OF WIRE BEFOREHAND.
THEN START TO THE OPERATION.

*INFERIOR SILICON GREASE CAN DAMAGE IC'S AND TRANSISTORS.
WHEN REPLACING AN IC OR TRANSISTOR, USE ONLY SPECIFIED SILICON
GREASE (YG6260).
REMOVE ALL THE OLD SILICON BEFORE APPLYING NEW SILICON.

MAJOR COMPONENTS LOCATION GUIDE

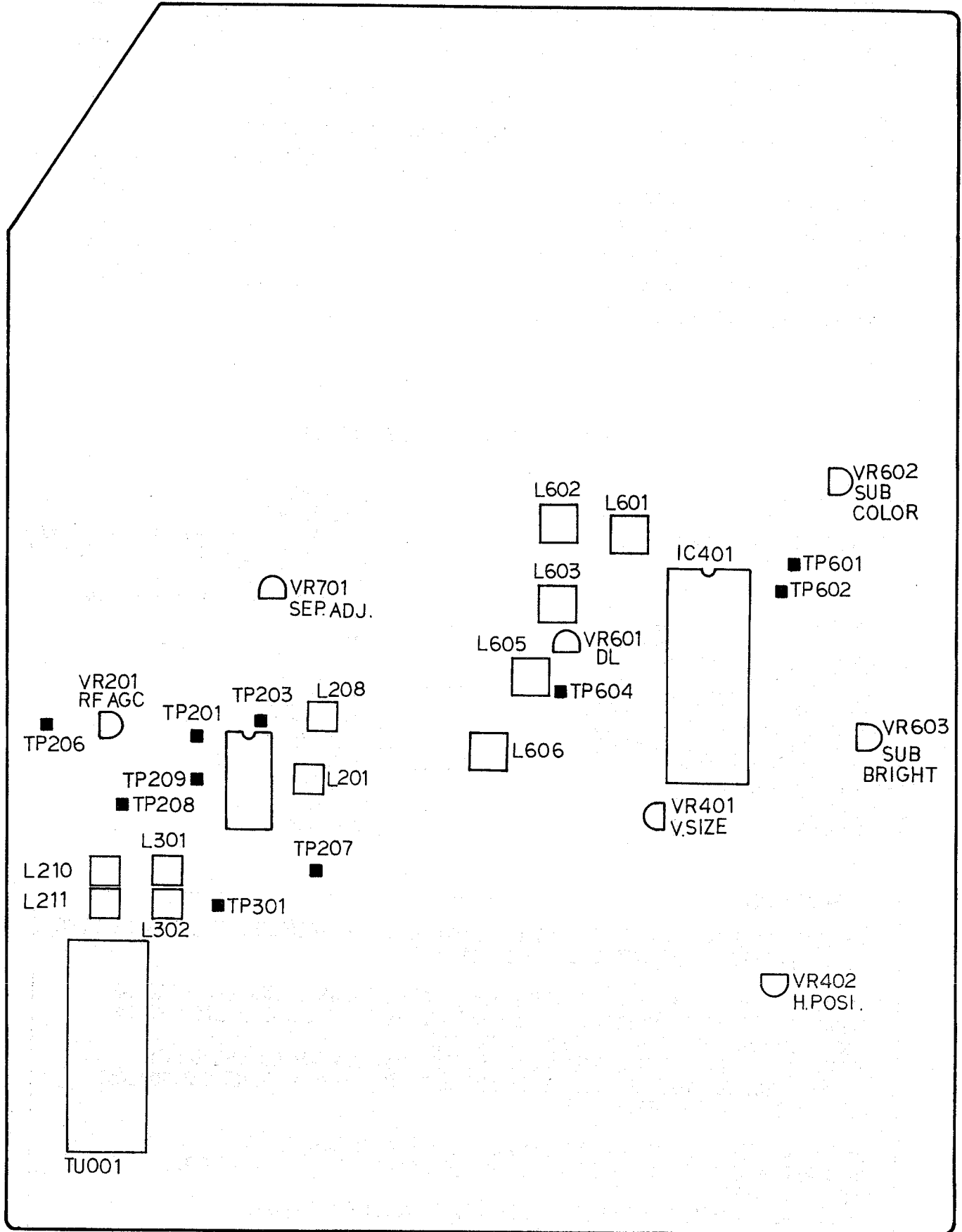

ALIGNMENT INSTRUCTIONS

SHUT DOWN CIRCUIT

When the high voltage rises, a simultaneous voltage increase will develop at terminal 10 of the Horizontal Output Transformer (FB401), and be applied to pin 52 of IC401. If excessive high voltage is produced, the increased voltage developed exceeds the rating of zener diode D405 causing the Horizontal Oscillator to stop functioning and the high voltage system to shut down.

VERTICAL SIZE ADJUSTMENT

Adjust the control (VR401) so that the picture fills the picture from top to bottom and is proportionate to the width.

RF AGC ADJUSTMENT

The RF AGC control is adjusted at the factory and rarely requires re-adjustment unless the received picture exhibits too much snow or the receiver lacks sensitivity. Home adjustment can be made by tuning in a weak snowy station and adjusting RF AGC for the least amount of snow. For a more accurate adjustment use the following procedure.

1. Inject a test pattern signal (80dB).
2. Adjust AGC pin of TV tuner (TP206) to 3.0V with VR201 control.

AFT ADJUSTMENT

1. Connect the output of the oscillator (38.9MHz) to the tuner pack IP.
2. Adjust L208 to keep constant DC voltage at TP207 with AFT ON and AFT OFF.

FOCUS ADJUSTMENT

Adjust focus control on the flyback transformer for a defined picture.

SUB BRIGHT ADJUSTMENT

1. Receive the signal of Monochrom pattern.
2. Set the Contrast and Brightness controls to maximum position.
3. Adjust the Sub Bright (VR603) control to obtain a dim white pattern on 25% of gray scale.

SUB COLOR ADJUSTMENT

1. Receive the signal of Color Bar pattern.
2. Connect the oscilloscope to TP802.
3. Press the NORMAL SW on the remote control.
4. Adjust the color level to 75% with VR602.

HUE DELAY ADJUSTMENT

1. Receive the signal of DEM pattern.
2. Connect dual oscilloscope to TP601 and TP602.
3. Adjust waveform to straight line with VR601 and L603.

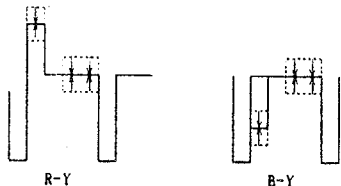

STEREO SEPARATION ADJUSTMENT

1. Receive the stereo signal.
2. Connect a digital voltmeter to L-ch Audio output.
3. Adjust output for L-ch to minimum with VR701.

H.POSITION ADJUSTMENT

1. Receive the test pattern signal.(PAL Philips)
2. Adjust horizontal picture position to center with VR402.

T' TEXT ADJUSTMENT

1. Receive the snowy station. (free-run)
2. Connect the frequency counter to 17pin of IC850.
3. Adjust frequency counter to 6.001MHz with TC851.

VCO, TRAP AND SIF ADJUSTMENT

(Refer to Figure 1)

TEST EQUIPMENT CONNECTION

OSCILLOSCOPE Set AC-DC switch to AC position.

SWEEP-MARKER GENERATOR Connect H SCOPE and V SCOPE output cable from SWEEP-MARKER GENERATOR to H and V input connectors on the OSCILLOSCOPE, connect hot lead of SWEEP-MARKER OUTPUT cable to test point TP209 on PCBO01; connect ground lead to chassis ground. Connect pick up SWEEP-MARKER INPUT cable to TP203; ground lead to chassis ground.

1. Connect 10K ohm variable resistor between TP201, B+ (12V) to ground. Install AGC VR to prevent saturation in waveform, then adjust AGC VR for proper size of waveform. On the other hand, in case IF AGC voltage is supplied externally, adjust for proper size of waveform on condition that IF AGC voltage is within 10V and is gradually decreased.
2. Adjust L201 to obtain maximum amplitude of response curve at 38.9 MHz. (Refer to Response Curve "A")
3. Re-connect hot lead of SWEEP-MARKER GENERATOR OUTPUT cable from TP209 to TV tuner IP.
4. Connect SWEEP-MARKER GENERATOR INPUT cable from IP203 to TP208.
5. Adjust L210 and L211 obtain maximum amplitude of response curve at 40.4 MHz and 32.4 MHz. (Refer to Response Curve "B")
6. Connect SWEEP-MARKER GENERATOR INPUT cable from IP208 to TP301. (With 10K ohm resistor)
7. Adjust L301 and L302 to obtain maximum amplitude of response curve at 33.4 MHz. (Refer to Response Curve "C")

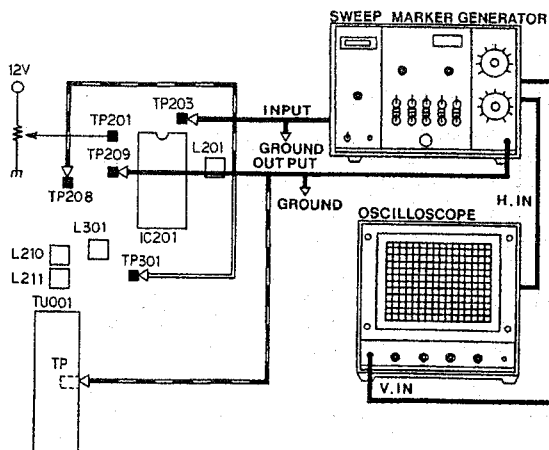
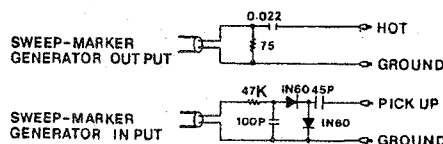
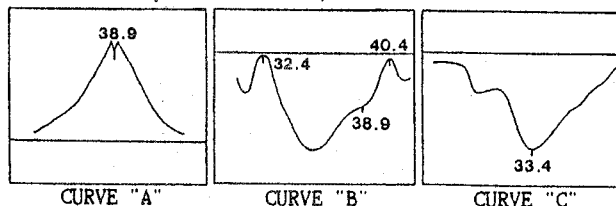

FIGURE 1

ALIGNMENT INSTRUCTIONS

SECAM CHROMA BANDPASS ALIGNMENT

(Refer to Figure 2)

TEST EQUIPMENT CONNECTION

GENERAL PAL-SECAM switch to SECAM position.
 SWEEP-MARKER GENERATOR . . . Connect H. SCOPE and V. SCOPE output cable from SWEEP-MARKER GENERATOR to H. and V. input connectors on the OSCILLOSCOPE, connect hot lead of SWEEP-MARKER OUTPUT cable to TP on TV tuner; connect ground lead to chassis ground.
 Connect pick up lead SWEEP-MARKER INPUT cable to TP604; ground lead to chassis ground.

1. Adjust L605 to obtain best overall response curve.
 (Refer to Response Curve "D")

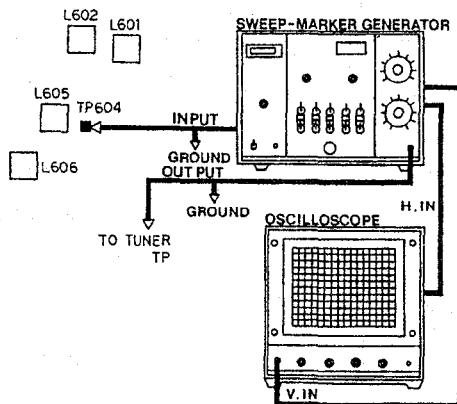
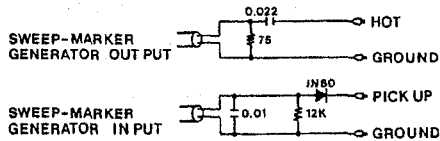
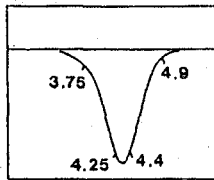

FIGURE 2

SECAM IDENT ADJUSTMENT

1. Receive the signal of secam color pattern.
2. Connect the oscilloscope to TP603 and ground.
3. Adjust the voltage to maximum with L606.

SECAM PHASE ADJUSTMENT

1. Receive the signal of secam color pattern.
2. Adjust L601 and L602 not to change the color of the pattern while tuning the Color control from minimum to maximum position.

BLOCK DIAGRAM

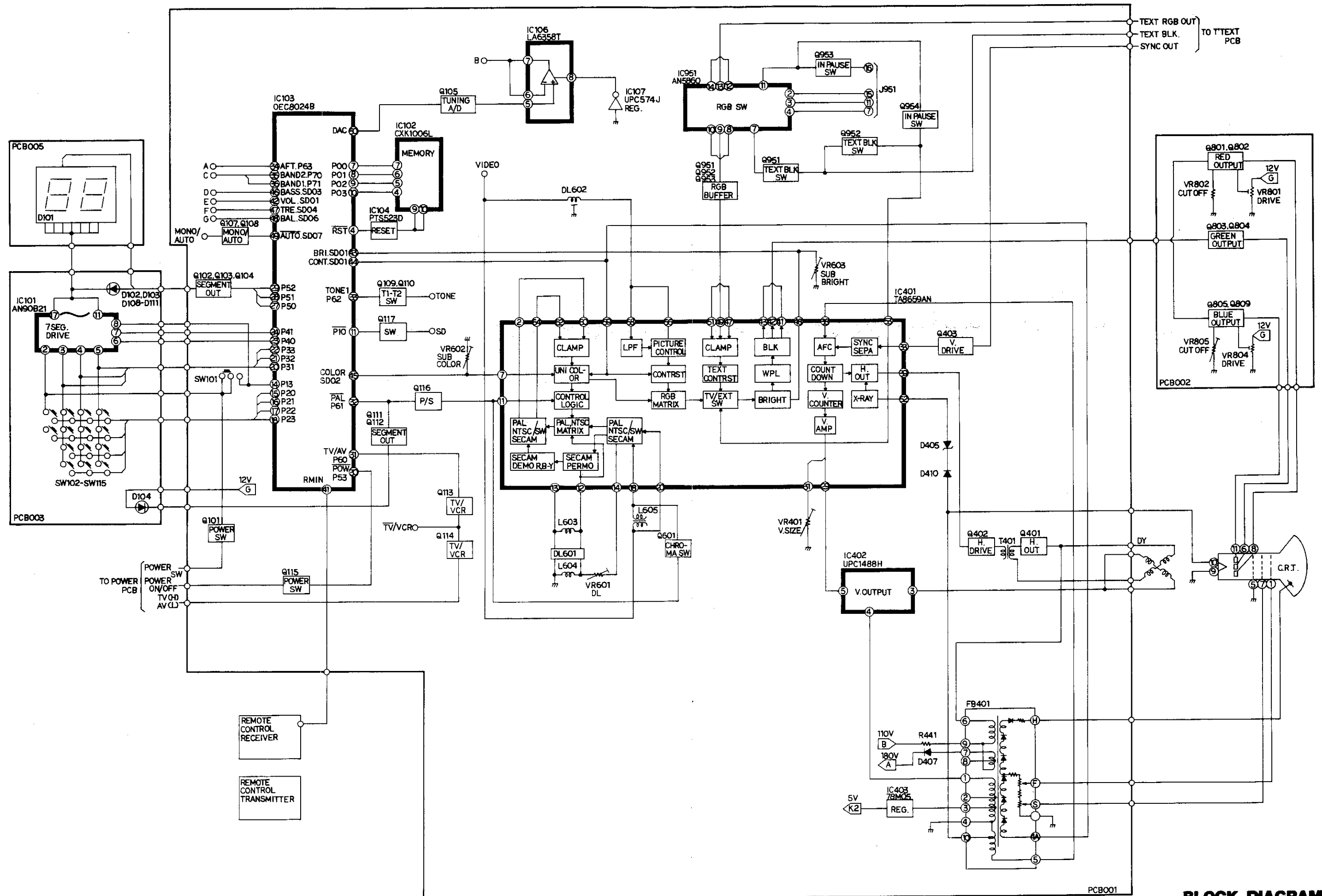

BLOCK DIAGRAM

MAIN P.C.BOARD

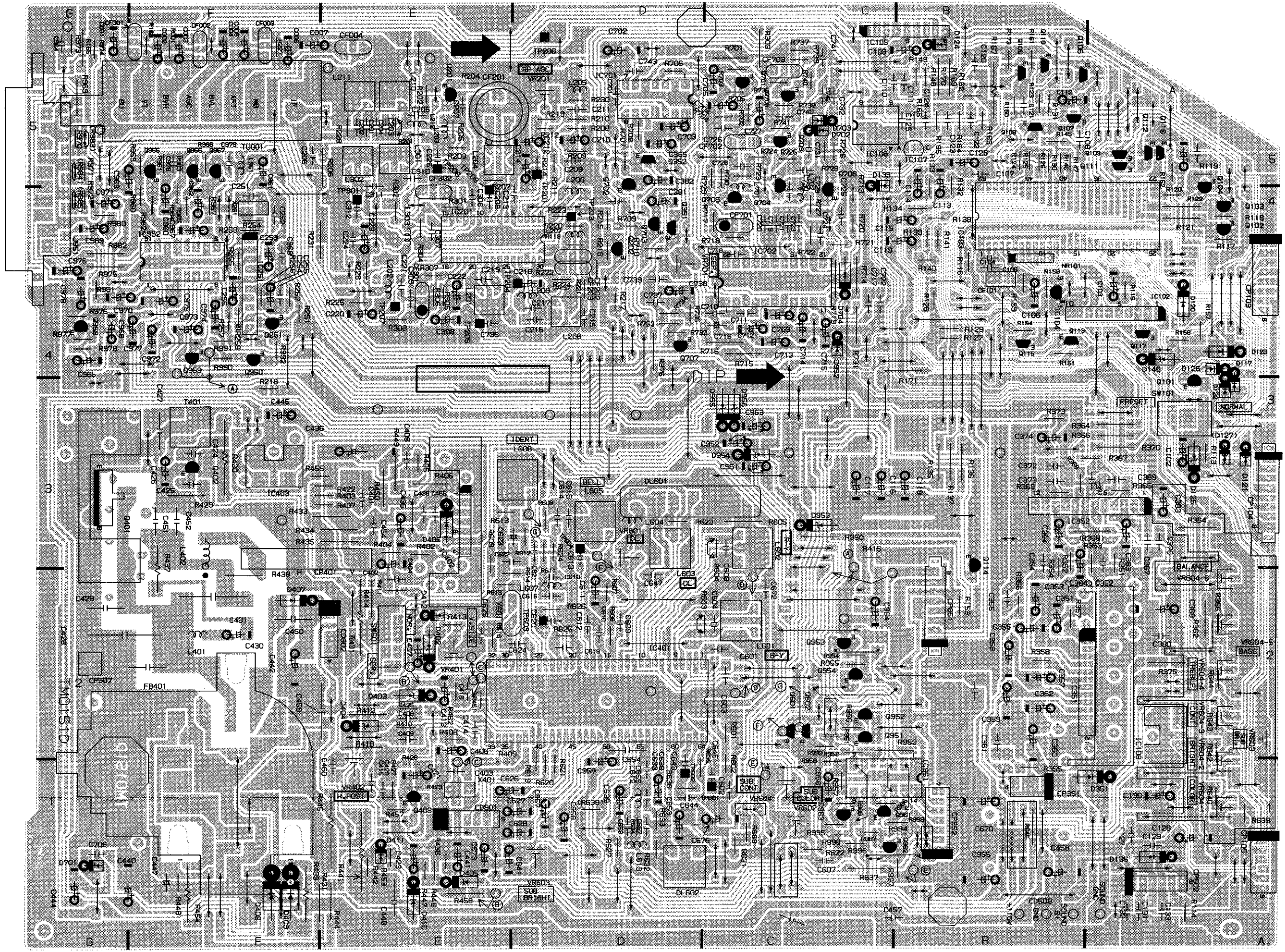

MAIN P.C.BOARD

CONTROL/LED/POWER SWITCH/ HEADPHONE JACK P.C.BOARD

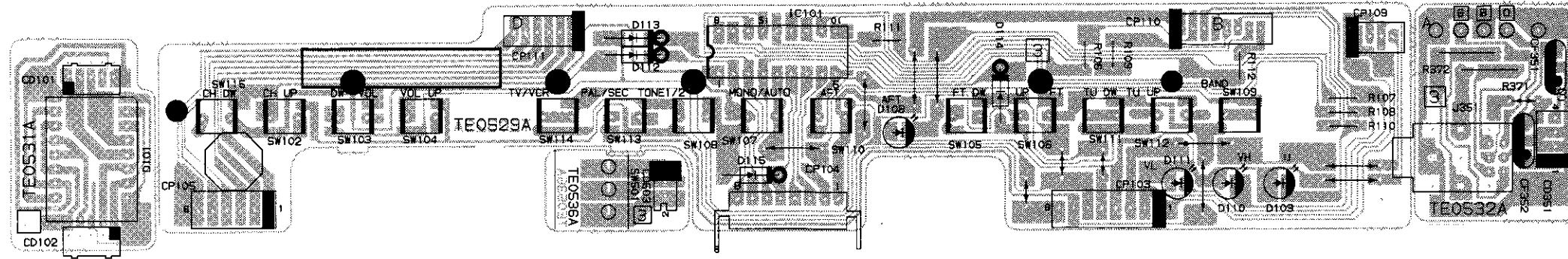

POWER P.C.BOARD

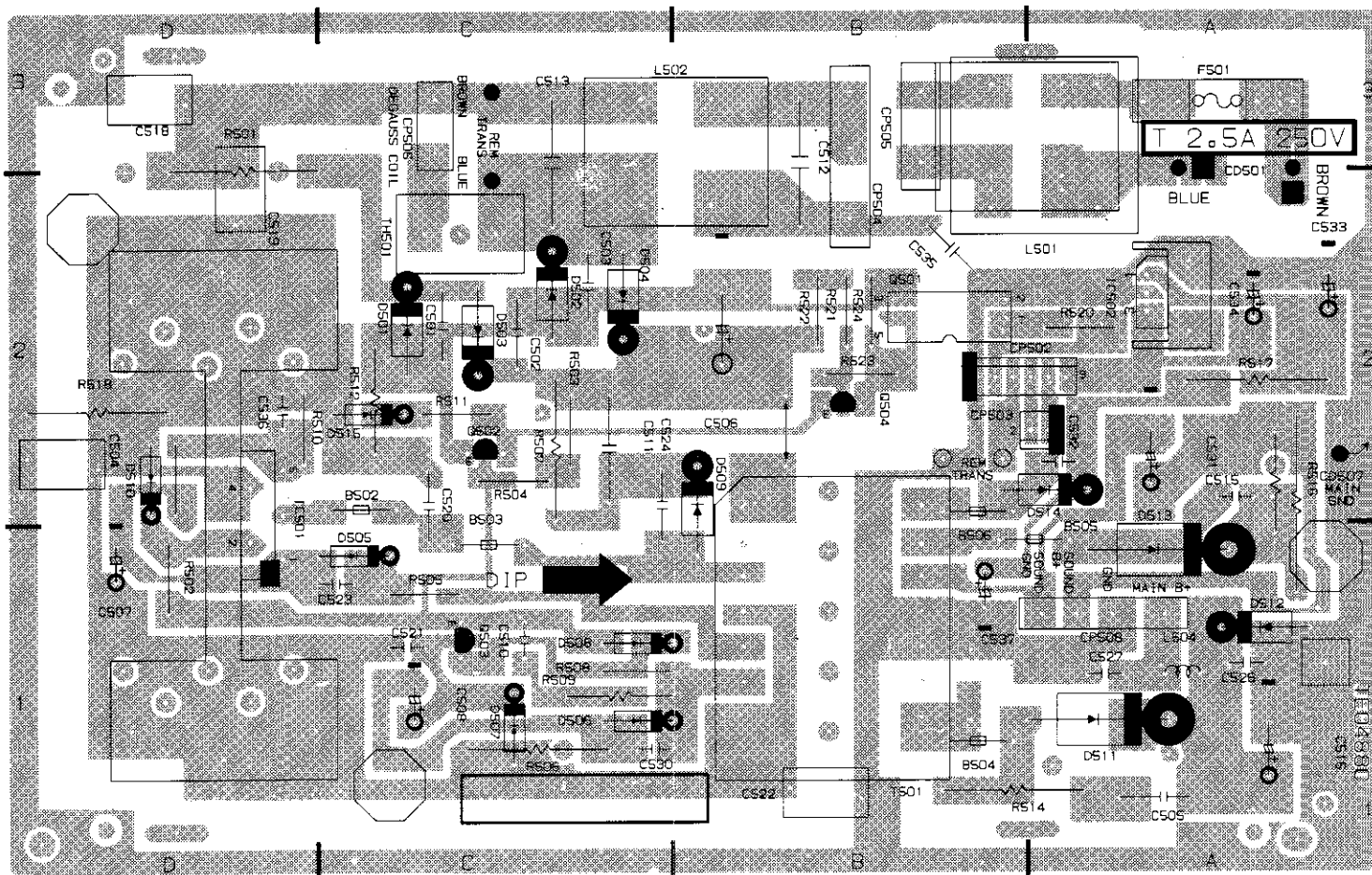

CRT P.C.BOARD

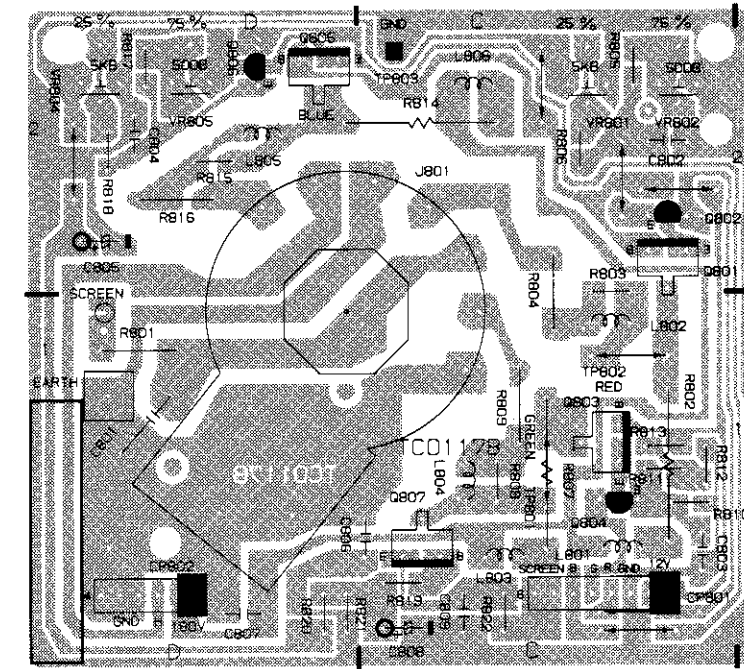

SPEAKER P.C.BOARD

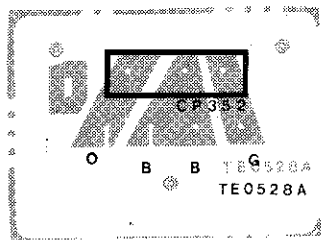

REMOCON P.C.BOARD

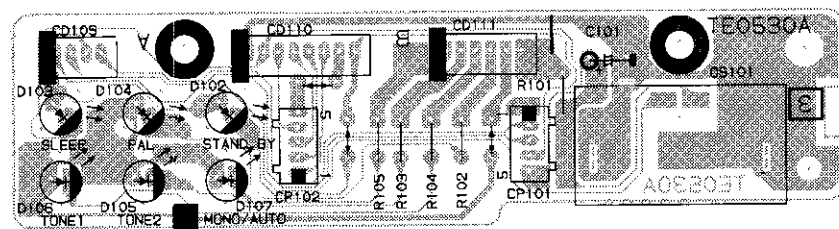

T'TEXT P.C.BOARD

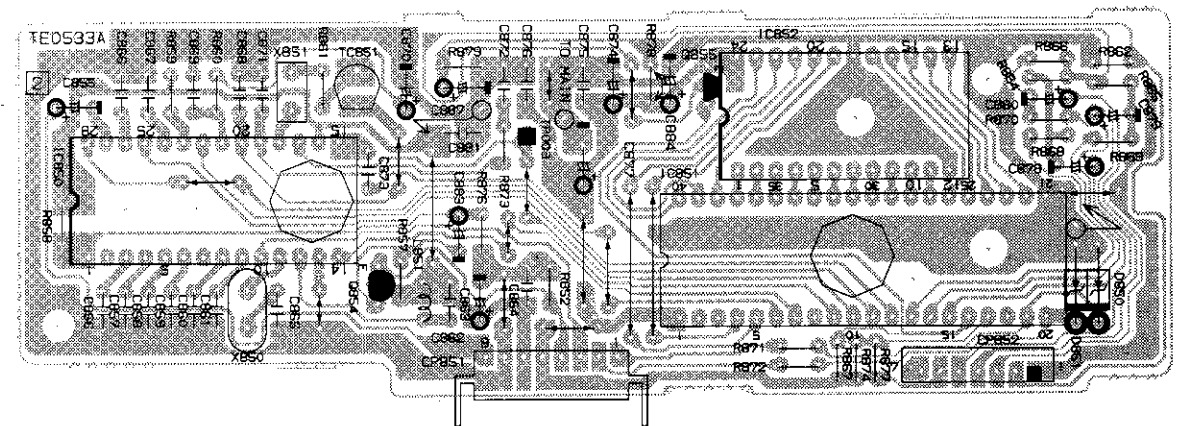

CHASSIS SCHEMATIC DIAGRAM

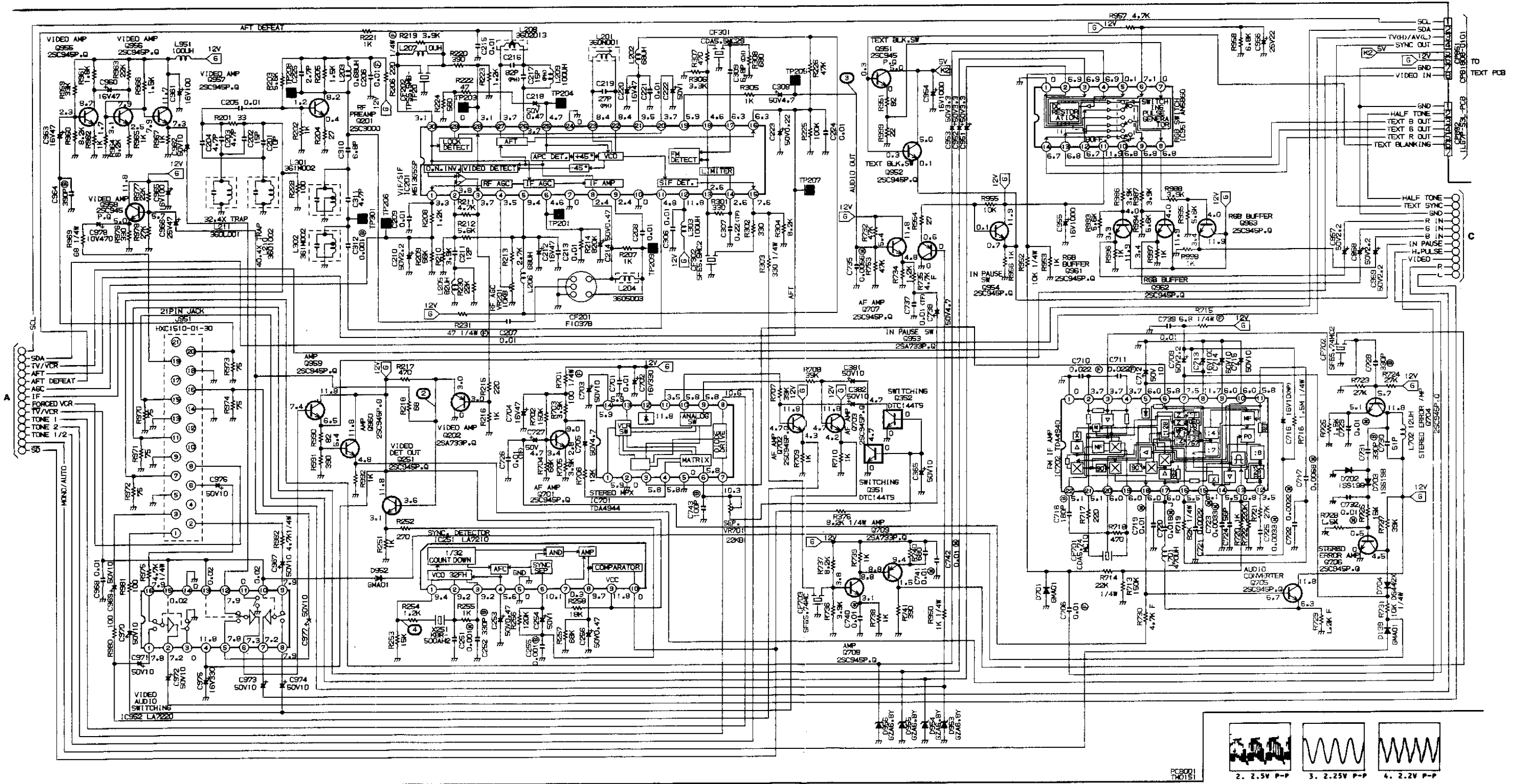

NOTE: F, G, H, I, AND J MARKED AROUND THE PARTS IN THE SCHEMATIC DIAGRAM INDICATES THE FOLLOWING ERROR RATE.
 F: *1X, G: *2X, H: *3X, I: *4X, J: *5X

CAUTION: SINCE THESE PARTS MARKED BY Δ ARE CRITICAL FOR SAFETY, USE ONES DESCRIBED ON PARTS LIST ONLY.

ATTENTION: LES PIÈCES RÉPARÉES PAR UN Δ ÉTANT DANGEREUSES AN POINT DE VUE SÉCURITÉ N'UTILISER QUE CELLES DÉCRITES DANS LA NOMENCLATURE DES PIÈCES.

NOTE: THIS SCHEMATIC DIAGRAM IS THE LATEST AT THE TIME OF PRINTING AND SUBJECT TO CHANGE WITHOUT NOTICE.

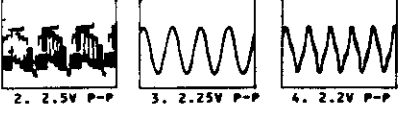

CAUTION: DIGITAL TRANSISTOR

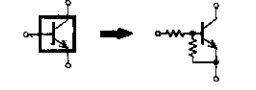

CHASSIS SCHEMATIC DIAGRAM

1-7806

CHASSIS SCHEMATIC DIAGRAM

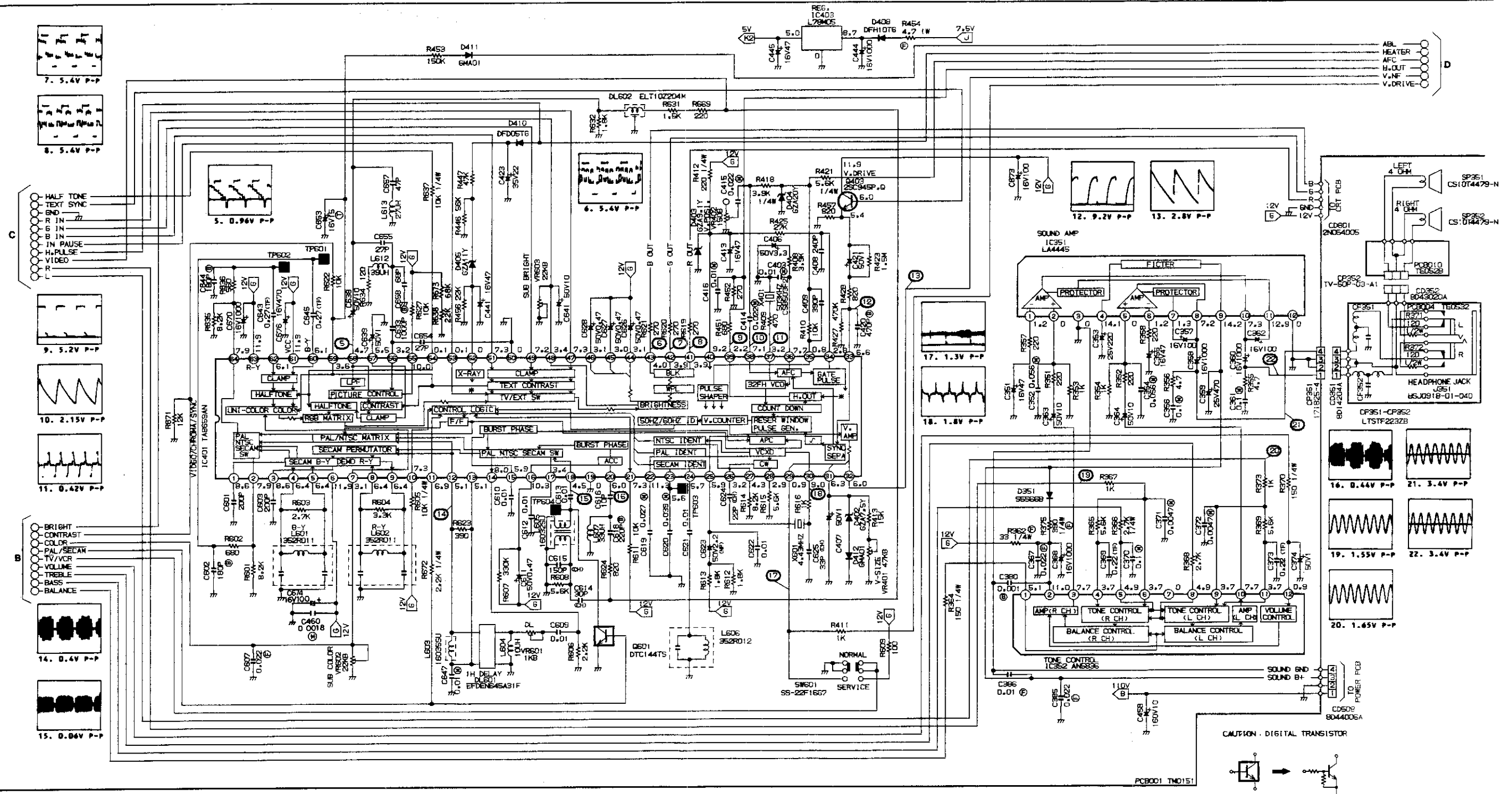

CAUTION: SINCE THESE PARTS MARKED BY Δ ARE CRITICAL FOR SAFETY, USE ONES DESCRIBED ON PARTS LIST ONLY.

ATTENTION: LES PIÈCES REPAREES PAR UN Δ ETANT DANGEREUSES AU POINT DE VUE SECURITE N'UTILISER QUE CELLES DECRIRES DANS LA NOMENCLATURE DES PIÈCES.

NOTE: THIS SCHEMATIC DIAGRAM IS THE LATEST AT THE TIME OF PRINTING AND SUBJECT TO CHANGE WITHOUT NOTICE.

CHASSIS SCHEMATIC DIAGRAM

1-7807

CHASSIS SCHEMATIC DIAGRAM

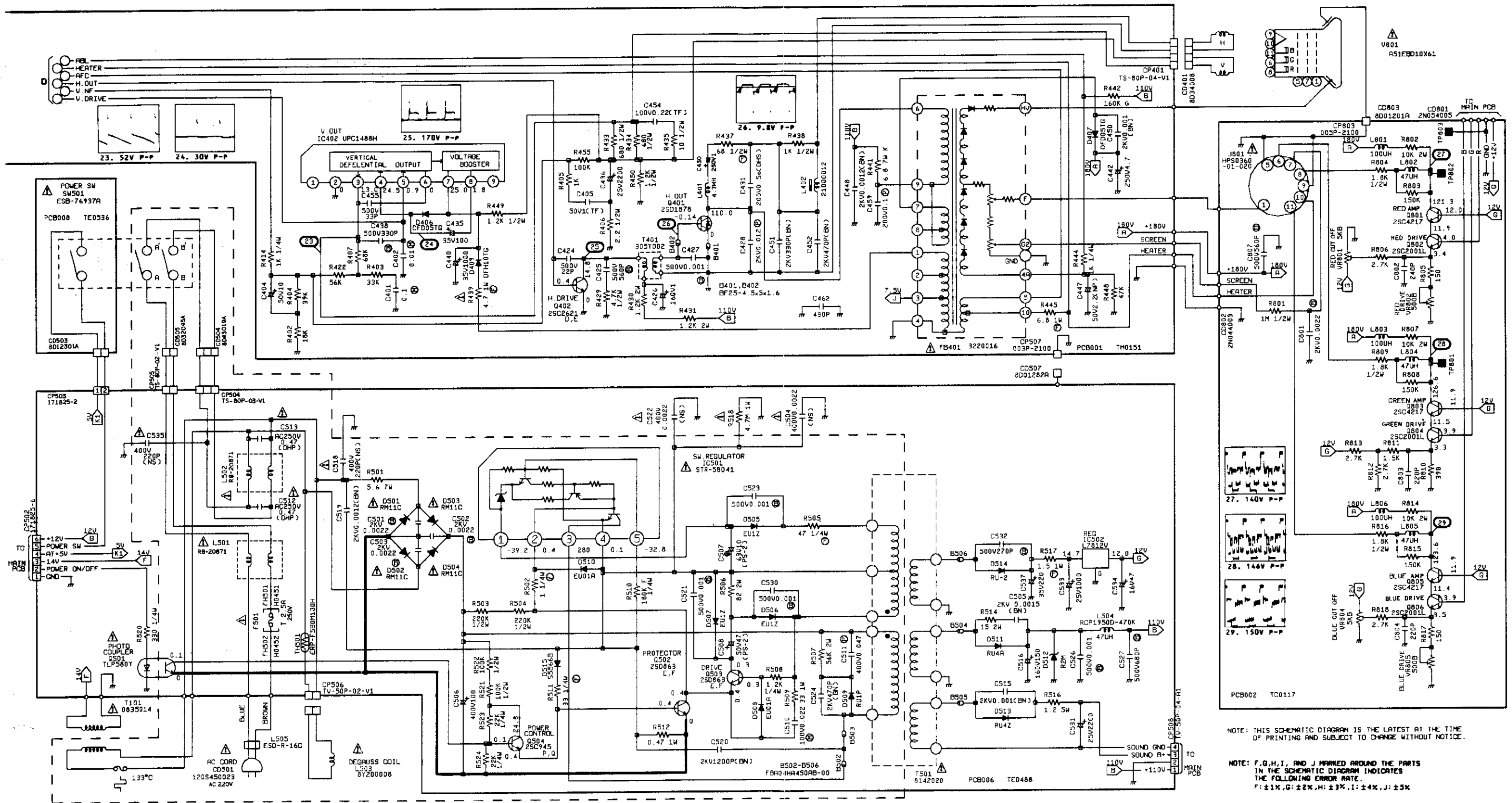

CAUTION: SINCE THESE PARTS MARKED BY Δ ARE CRITICAL FOR SAFETY, USE ONES DESCRIBED ON PARTS LIST ONLY.

ATTENTION: LES PIÈCES REPARÉES PAR UN Δ ÉTANT DANGEREUSES AU POINT DE VUE SÉCURITÉ, N'UTILISER QUE CELLES DÉCRITES DANS LA NOMÉNCLATURE DES PIÈCES.

NOTE: THIS SCHEMATIC DIAGRAM IS THE LATEST AT THE TIME OF PRINTING AND SUBJECT TO CHANGE WITHOUT NOTICE.

NOTE: F, G, H, I, AND J MARKED AROUND THE PARTS IN THE SCHEMATIC DIAGRAM INDICATES THE FOLLOWING ERROR RATE:
 F: $\pm 1\%$, G: $\pm 2\%$, H: $\pm 3\%$, I: $\pm 4\%$, J: $\pm 5\%$

CHASSIS SCHEMATIC DIAGRAM

CHASSIS SCHEMATIC DIAGRAM

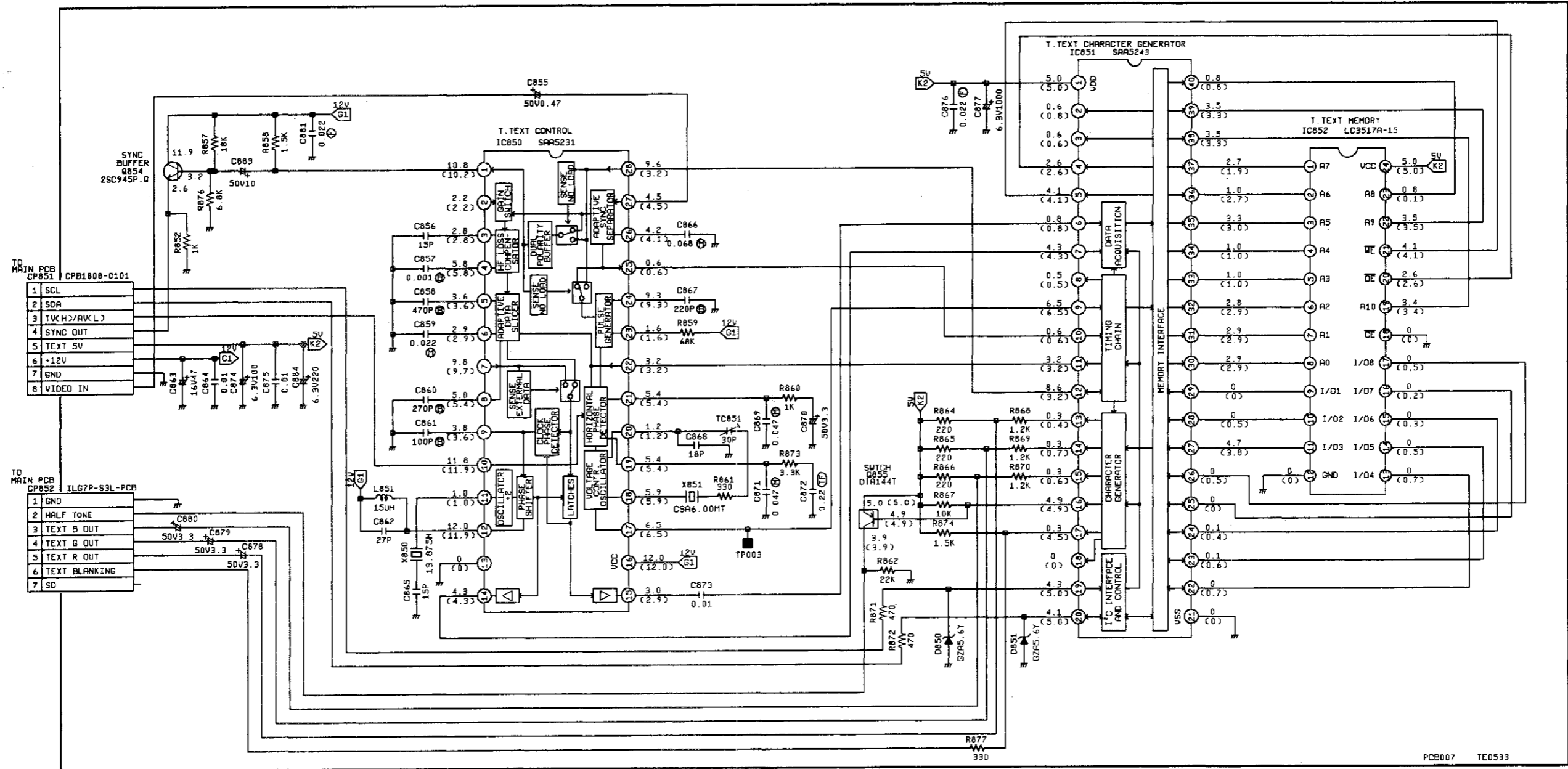

CAUTION: DIGITAL TRANSISTOR

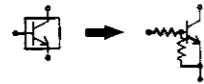

NOTE: THIS SCHEMATIC DIAGRAM IS THE LATEST AT THE TIME OF PRINTING AND SUBJECT TO CHANGE WITHOUT NOTICE.

NOTE: THE FIGURE WITH () IS THE VOLTAGE IN NORMAL TV OPERATION. THE FIGURE WITHOUT () IS THE VOLTAGE IN TELETEXT OPERATION.

CHASSIS SCHEMATIC DIAGRAM

MECHANICAL REPLACEMENT PARTS LIST

REF. NO	PART NO	DESCRIPTION	
101	A37402A723	CABINET.FRONT ASS'Y	
102	712TPJ0103	DOOR	
103	704TPC0001	FOOT	
104	735TPA0085	BUTTON.PUSH	
105	735TPA0101	BUTTON.POWER	
106	A37402A743	CABINET.BACK ASS'Y	
		SHEET.RATING	
107	709TPA0049	HOLDER.SPEAKER	
109	762TSA0018	ANGLE.CRT	
110	800TRO0016	SHEET.CRT SUPPORT	
111	741TUA0003	SPRING.EARTH	
112	751JNA0004	PLATE.EARTH WIRE	
113	899PEC0340	CORD CLAMP NO.PEC-034-0	
201	8110240B04	TAP TITE(P) BIND	4*20 CH
202	8110630A24	TAP TITE(P) BRAZIER	3*12 CH
203	8117E30A04	TAPPING(B0) WH10	3*10 CH
204	8110630804	TAP TITE(P) BRAZIER	3*8 CH
205	8117540A64	TAPPING(B0) TRUSS	4*16 CH
206	8110630A04	TAP TITE(P) BRAZIER	3*10 CH
207	8300560004	SL NUT	M6
208	82A60A8164	PLAIN WASHER	6.3*18*T1.6
---	J3700102A	GUARANTEE CARD	
---	J3700128A	WARNING SHEET	
---	J3740201A	INSTRUCTION BOOK	
---	J3740203A	SCHEMATIC DIAGRAM	
---	792THA0113	PACKAGE.TOP	
---	792THA0114	PACKAGE.BOTTOM	
---	793TCD0642	GIFT BOX	

THIS ELECTRICAL PARTS LIST IS A STANDARD PART LIST, BUT INTERCHANGEABLE PARTS MAY BE USED IN THE UNIT. SEE THE INTERCHANGEABLE PARTS LIST AFTER THE STANDARD PARTS LIST.

ELECTRICAL REPLACEMENT PARTS LIST

REF. NO	PART. NO	DESCRIPTION	REF. NO	PART. NO	DESCRIPTION
-RESISTORS-			-SEMI CONDUCTORS (CONT)-		
R167	R3B181123J	R, METAL OXIDE 12K OHM 1 W	D104	0021120030	LED LN81RCPH
R206	R615U4221J	R, FUSE 220 OHM 1/4W	D105	0021120030	LED LN81RCPH
R231	R615U4470J	R, FUSE 47 OHM 1/4W	D106	0021120030	LED LN81RCPH
R362	R615U4330J	R, FUSE 33 OHM 1/4W	D107	0021120030	LED LN81RCPH
R430	R3B18A122J	R, METAL OXIDE 1.2K OHM 2 W	D108	0021120030	LED LN81RCPH
R431	R3B18A122J	R, METAL OXIDE 1.2K OHM 2 W	D109	0021120030	LED LN81RCPH
R437	R61582680J	R, FUSE 68 OHM 1/2W	D110	0021120030	LED LN81RCPH
△ R439	R615814R7J	R, FUSE 4.7 OHM 1 W	D111	0021120030	LED LN81RCPH
R441	R5A2CE6R8K	R, CEMENT 6.8 OHM 7 W	D112	D13TDS442X	DIODE, SILICON DS442X-BT
R445	R614816R8J	R, FUSE 6.8 OHM 1 W	D113	D13TDS442X	DIODE, SILICON DS442X-BT
R454	R615814R7J	R, FUSE 4.7 OHM 1 W	D114	D13TDS442X	DIODE, SILICON DS442X-BT
R501	R5A2CE5R6K	R, CEMENT 5.6 OHM 7 W	D115	D13TDS442X	DIODE, SILICON DS442X-BT
R502	R63584010J	R, FUSE 1 OHM 1/4W	D117	D13TGM0A010	DIODE, SILICON GMA-01-BT
R505	R61584470J	R, FUSE 47 OHM 1/4W	D121	D13TGM0A010	DIODE, SILICON GMA-01-BT
R506	R3B18A820J	R, METAL OXIDE 82 OHM 2 W	D122	D13TGM0A010	DIODE, SILICON GMA-01-BT
R507	R3B18A563J	R, METAL OXIDE 56K OHM 2 W	D123	D93T05R10X	DIODE, ZENER GZA5.1 X BT
R509	R3B181330J	R, METAL OXIDE 33 OHM 1 W	D124	D13TGM0A010	DIODE, SILICON GMA-01-BT
R511	R61584330J	R, FUSE 33 OHM 1/4W	D125	D93T05R10X	DIODE, ZENER GZA5.1 X BT
R512	R4B181R47J	R, METAL OXIDE 0.47 OHM 1 W	D126	D13TGM0A010	DIODE, SILICON GMA-01-BT
R514	R3B28A150J	R, METAL OXIDE 15 OHM 2 W	D136	D25T5566B0	DIODE, RECTIFIER S5566B
R516	R5A2CD1R2K	R, CEMENT 1.2 OHM 5 W	D139	D13TGM0A010	DIODE, SILICON GMA-01-BT
△ R517	R614811R5J	R, FUSE 1.5 OHM 1 W	D140	D93T05R60Y	DIODE, ZENER GZA5.6 Y BT
R518	R03101475J	RC 4.7 MOHM 1 W	D351	D25T5566B0	DIODE, RECTIFIER S5566B
R672	R00104222J	RC 2.2K OHM 1/4W	D402	D93T07R50Y	DIODE, ZENER GZA7.5 Y BT
R673	R00106683J	RC 68K OHM 1/6W	D403	D93T09R10Y	DIODE, ZENER GZA9.1 Y BT
R715	R615U46R8J	R, FUSE 6.8 OHM 1/4W	D404	D93T02000Y	DIODE, ZENER GZA20 Y BT
R802	R3B18A103J	R, METAL OXIDE 10K OHM 2 W	D405	D93T01100Y	DIODE, ZENER GZA11 Y BT
R807	R3B18A103J	R, METAL OXIDE 10K OHM 2 W	D406	D23TFD05TG	DIODE, RECTIFIER DFD05TG-BT
R814	R3B18A103J	R, METAL OXIDE 10K OHM 2 W	D407	D23TFD05TG	DIODE, RECTIFIER DFD05TG-BT
			D408	D23TFH10TG	DIODE, RECTIFIER DFH10TG-AT1
-CAPACITORS-			D409	D23TFH10TG	DIODE, RECTIFIER DFH10TG-AT1
C008	COA0B04U3K	CC 6800 PF	D410	D23TFD05TG	DIODE, RECTIFIER DFD05TG-BT
C206	COABF0414Z	CC 0.01 UF	D411	D13TGM0A010	DIODE, SILICON GMA-01-BT
C358	E0B7F2102M	CE 1000 UF 16V	D412	D13TGM0A010	DIODE, SILICON GMA-01-BT
C360	E0B7F2102M	CE 1000 UF 16V	△ D501	D2BTRM11C0	DIODE, RECTIFIER RM11C
C368	E0B7F2102M	CE 1000 UF 16V	△ D502	D2BTRM11C0	DIODE, RECTIFIER RM11C
C385	COABF04H4Z	CC 0.022 UF	△ D503	D2BTRM11C0	DIODE, RECTIFIER RM11C
C386	COABF0414Z	CC 0.01 UF	D504	D2BTRM11C0	DIODE, RECTIFIER RM11C
C428	P4A2F6123J	CMPP 0.012 UF 2KV	D505	D2BH00EU1Z	DIODE, RECTIFIER EU1Z
C431	P4A1F2564J	CMPP 0.56 UF 200V	D506	D2BH00EU1Z	DIODE, RECTIFIER EU1Z
C436	E0B7F3222M	CE 2200 UF 25V	D507	D2BH00EU1Z	DIODE, RECTIFIER EU1Z
C440	E0B7F4102M	CE 1000 UF 35V	D508	D2BTOEU01A	DIODE, RECTIFIER EU01AV1
C444	E0B7F2102M	CE 1000 UF 16V	D509	D2B00RU1P0	DIODE, RECTIFIER RU1P
C448	C0D4BN7B3K	CC 1200 PF 2KV BN	D510	D2BTOEU01A	DIODE, SILICON EU01AV1
C450	C0D4BN713K	CC 1000 PF 2KV BN	D511	D2BF0RU4A0	DIODE, SILICON RU4A
C451	C0D4BN7L2K	CC 330 PF 2KV BN	D512	D2B000R2M0	DIODE, AVARANCHE R2M
C452	C0D4BN7Q2K	CC 470 PF 2KV BN	D513	D2BJ00RU4Z	DIODE, RECTIFIER RU4Z
C458	E0B50B100M	CE 10 UF 160V	D514	D2BF00RU20	DIODE, SILICON RU-2
C459	P3A1F2104J	CPP 0.1 UF 200V	D515	D25T5566B0	DIODE, RECTIFIER S5566B
C460	P1E400182K	CP 0.0018UF 50V	D701	D13TGM0A010	DIODE, SILICON GMA-01-BT
C462	COA0SL4P2K	CC 430 PF	D702	D14T0S1980	DIODE, SILICON 1SS198TE
C501	COABBO7H3K	CC 2200 PF 2KV B	D703	D14T0S1980	DIODE, SILICON 1SS198TE
C502	COABBO7H3K	CC 2200 PF 2KV B	D704	D13TDS442X	DIODE, SILICON DS442X-BT
C503	COABBO7H3K	CC 2200 PF 2KV B	D850	D93T05R60Y	DIODE, ZENER GZA5.6 Y BT
△ C504	CA1B30KH3M	CC 2200 PF 400V AC	D851	D93T05R60Y	DIODE, ZENER GZA5.6 Y BT
C505	C0D4BN7E3K	CC 1500 PF 2KV BN	D952	D13TGM0A010	DIODE, SILICON GMA-01-BT
C506	E53COH101M	CE 100 UF 400V	D953	D93T06R80Y	DIODE, ZENER GZA6.8 Y BT
C507	E02QF6100M	CE 10 UF 63V	D954	D93T06R80Y	DIODE, ZENER GZA6.8 Y BT
C508	E02QF5470M	CE 47 UF 50V	D955	D93T06R80Y	DIODE, ZENER GZA6.8 Y BT
C511	P341F4473J	CPP 0.047 UF 400V	D956	D93T06R80Y	DIODE, ZENER GZA6.8 Y BT
△ C512	P444FB474M	CMPP 0.47 UF 250V	IC101	I01D10B210	IC AN90B21
△ C513	P444FB474M	CMPP 0.47 UF 250V	IC102	I30S1006L0	IC CXK1006L
C515	C0D4BN713K	CC 1000 PF 2KV BN	IC103	I51D08024B	IC OEC8024B
C516	E025FB151M	CE 150 UF 160V	IC104	I0L9T7523D	IC PST523D
△ C518	CA1B30KH2M	CC 220 PF 400V AC	IC105	I03S079100	IC LA7910
C519	C0D4BN7B3K	CC 1200 PF 2KV BN	IC106	I03D06358T	IC LA6358T
C520	C0D4BN7B3K	CC 1200 PF 2KV BN	IC107	I02190574J	IC UPC574J-T
△ C522	CA1B30KH3M	CC 2200 PF 400V AC	IC108	I03B98M050	IC L78M05-SA
C524	C0D4BN7Q2K	CC 470 PF 2KV BN	IC201	I06DA365SP	IC M51365SP
C531	E0B7F3222M	CE 2200 UF 25V	IC251	I03S072100	IC LA7210
C533	E0B7F3102M	CE 1000 UF 25V	IC351	I03SP44450	IC LA4445
△ C535	CA1B30KQ2M	CC 470 PF 400V AC	IC352	I01S058360	IC AN5836
C670	E0B7F2102M	CE 1000 UF 16V	IC401	I05DE86590	IC TA8659AN
C674	E0B702101M	CE 100 UF 16V	IC402	I02SD14880	IC UPC1488H
C801	COABBO7H3K	CC 2200 PF 2KV B	IC403	I03B98M050	IC L78M05-SA
C877	EOA1F0102M	CE 1000 UF 6.3V	△ IC501	I2B4980410	IC STR-58041
C954	E0B7F2102M	CE 1000 UF 16V	IC502	I03B97812V	IC L7812V-SA
C955	E0B7F2102M	CE 1000 UF 16V	IC701	I0EDF49440	IC TDA4944
			IC702	I0EDF49400	IC TDA4940
			IC850	I9KDF52310	IC SAA5231
-SEMI CONDUCTORS-					
D101	0042122003	LED DISPLAY LN524RAS			
D102	0021120030	LED LN81RCPH			
D103	0021120030	LED LN81RCPH			

ELECTRICAL REPLACEMENT PARTS LIST

REF. NO	PART. NO	DESCRIPTION	REF. NO	PART. NO	DESCRIPTION
-SEMICONDUCTORS (CONT)-			-COILS & TRANSFORMERS (CONT)-		
IC851	I4KDF52430	IC SAA5243	△ L503	028Y200008	COIL, DEGAUSS 8Y200008
IC852	I53D03517C	IC LC3517A-15	L504	02100B470K	COIL RCP1950D-470K 47 UH
IC951	I01D058600	IC ANS860	L505	02AXA509C1	COIL, LINE FILTER ESD-R-16C
IC952	I03D072200	IC LAT7220	L601	03352R011C	COIL, CHROMA 352R011
Q101	TCLT009450	TRANSISTOR, SILICON 2SC945A(C)-T	L602	03352R011C	COIL, CHROMA 352R011
Q102	TA2T009520	TRANSISTOR, SILICON 2SA952-T	L603	03352R007C	COIL, CHROMA 16035SU
Q103	TA2T009520	TRANSISTOR, SILICON 2SA952-T	L604	021JA6100K	COIL LAL02TA100K 10 UH
Q104	TA2T009520	TRANSISTOR, SILICON 2SA952-T	L605	03302R001C	COIL, CHROMA 16032SU
Q105	TCLT009450	TRANSISTOR, SILICON 2SC945A(C)-T	L606	03352R012C	COIL, CHROMA 352R012
Q106	TN7TD03002	COMPOUND TRANSISTOR(IC) DTC144TS	L607	021JA6330K	COIL LAL02TA330K 33 UH
Q107	TN7TD03001	COMPOUND TRANSISTOR(IC) DTC144ESTP	L612	021JA6390K	COIL LAL02TA390K 39 UH
Q108	TP7TD03001	COMPOUND TRANSISTOR(IC) DTA144E S-T	L613	021JA6270K	COIL LAL02TA270K 27 UH
Q109	TP7TD03002	COMPOUND TRANSISTOR(IC) DTA144TS	L701	021Z63471K	COIL EL0606SKI-471K 470 UH Q=45
Q110	TN7TD03001	COMPOUND TRANSISTOR(IC) DTC144ESTP	L702	021JA6120K	COIL LAL02TA120K 12 UH
Q111	TP7TD03002	COMPOUND TRANSISTOR(IC) DTA144TS	L801	021Z73101K	COIL EL0606RA-101K 100 UH Q=45
Q112	TN7TD03001	COMPOUND TRANSISTOR(IC) DTC144ESTP	L802	021Z73470K	COIL EL0606RA-470K 47 UH Q=50
Q113	TN7TD03002	COMPOUND TRANSISTOR(IC) DTC144TS	L803	021Z73101K	COIL EL0606RA-101K 100 UH Q=45
Q114	TN7TD03002	COMPOUND TRANSISTOR(IC) DTC144TS	L804	021Z73470K	COIL EL0606RA-470K 47 UH Q=50
Q115	TP7TD03002	COMPOUND TRANSISTOR(IC) DTA144TS	L805	021Z73470K	COIL EL0606RA-470K 47 UH Q=50
Q116	TN7TD03002	COMPOUND TRANSISTOR(IC) DTC144TS	L806	021Z73101K	COIL EL0606RA-101K 100 UH Q=45
Q117	TN7TD03001	COMPOUND TRANSISTOR(IC) DTC144ESTP	L851	021Z73150K	COIL EL0606RA-150K 15 UH Q=50
Q201	TC3T030000	TRANSISTOR, SILICON 2SC3000-AA	L951	021Z73101K	COIL EL0606RA-101K 100 UH Q=45
Q202	TALT007330	TRANSISTOR, SILICON 2SA733(C)-T ALL	△ T101	040835014Z	TRANSFORMER, POWER AC 0835014
Q251	TCLT009450	TRANSISTOR, SILICON 2SC945A(C)-T	△ T401	03305Y002C	TRANS., HORIZONTAL DRIVE 305Y002
Q351	TN7TD03002	COMPOUND TRANSISTOR(IC) DTC144TS	△ T501	0481420205	CONVERTER TRANSFORMER 8142020
Q352	TN7TD03002	COMPOUND TRANSISTOR(IC) DTC144TS	- JACKS -		
Q401	TD3FD18780	TRANSISTOR, SILICON 2SD1878	△ J351	0602131001	JACK, RCA 3.5 HSJ0918-01-040
Q402	TC30026210	TRANSISTOR, SILICON 2SC2621	J801	0662130007	SOCKET, CRT HPS0360-01-020
Q403	TCLT009450	TRANSISTOR, SILICON 2SC945A(C)-T	J951	0632100006	SOCKET, .21 PIN HXC1510-01-300
Q501	000250003Y	PHOTO COUPLER TLP580Y	- SWITCHES -		
Q502	TD3T008630	TRANSISTOR, SILICON 2SD863-AE	SW101	0500101016	SWITCH, PUSH ESB4111125
Q503	TD3T008630	TRANSISTOR, SILICON 2SD863-AE	SW102	0504101T14	SWITCH, TACT EVQ-QTE05G
Q504	TCLT009450	TRANSISTOR, SILICON 2SC945A(C)-T	SW103	0504101T14	SWITCH, TACT EVQ-QTE05G
Q601	TN7TD03002	COMPOUND TRANSISTOR(IC) DTC144TS	SW104	0504101T14	SWITCH, TACT EVQ-QTE05G
Q701	TCLT009450	TRANSISTOR, SILICON 2SC945A(C)-T	SW105	0504101T14	SWITCH, TACT EVQ-QTE05G
Q702	TCLT009450	TRANSISTOR, SILICON 2SC945A(C)-T	SW106	0504101T14	SWITCH, TACT EVQ-QTE05G
Q703	TCLT009450	TRANSISTOR, SILICON 2SC945A(C)-T	SW107	0504101T14	SWITCH, TACT EVQ-QTE05G
Q704	TCLT009450	TRANSISTOR, SILICON 2SC945A(C)-T	SW108	0504101T14	SWITCH, TACT EVQ-QTE05G
Q705	TCLT009450	TRANSISTOR, SILICON 2SC945A(C)-T	SW109	0504101T14	SWITCH, TACT EVQ-QTE05G
Q706	TCLT009450	TRANSISTOR, SILICON 2SC945A(C)-T	SW110	0504101T14	SWITCH, TACT EVQ-QTE05G
Q707	TCLT009450	TRANSISTOR, SILICON 2SC945A(C)-T	SW111	0504101T14	SWITCH, TACT EVQ-QTE05G
Q708	TCLT009450	TRANSISTOR, SILICON 2SC945A(C)-T	SW112	0504101T14	SWITCH, TACT EVQ-QTE05G
Q709	TALT007330	TRANSISTOR, SILICON 2SA733(C)-T ALL	SW113	0504101T14	SWITCH, TACT EVQ-QTE05G
Q801	TC3F042170	TRANSISTOR, SILICON 2SC4217-RAC	SW114	0504101T14	SWITCH, TACT EVQ-QTE05G
Q802	TC2T02001L	TRANSISTOR, SILICON 2SC2001LT	SW115	0504101T14	SWITCH, TACT EVQ-QTE05G
Q803	TC3F042170	TRANSISTOR, SILICON 2SC4217-RAC	SW116	0504101T14	SWITCH, TACT EVQ-QTE05G
Q804	TC2T02001L	TRANSISTOR, SILICON 2SC2001LT	SW117	0504101T14	SWITCH, TACT EVQ-QTE05G
Q805	TC3F042170	TRANSISTOR, SILICON 2SC4217-RAC	SW118	0504101T14	SWITCH, TACT EVQ-QTE05G
Q806	TC2T02001L	TRANSISTOR, SILICON 2SC2001LT	△ SW501	0530102008	SWITCH, PUSH ESB-76937A
Q854	TCLT009450	TRANSISTOR, SILICON 2SC945A(C)-T	SW601	0510B22001	SWITCH, SLIDE SS-22F16G7
Q855	TP7TD03002	COMPOUND TRANSISTOR(IC) DTA144TS	- VARIABLE RESISTORS -		
Q951	TCLT009450	TRANSISTOR, SILICON 2SC945A(C)-T	VR201	V126314B01	VR, SEMIFIXED RH0615C14J0F
Q952	TCLT009450	TRANSISTOR, SILICON 2SC945A(C)-T	VR401	V126304B03	VR, SEMIFIXED RH0624CS4J0A
Q953	TALT007330	TRANSISTOR, SILICON 2SA733(C)-T ALL	VR402	V1263E2B01	VR, SEMIFIXED RH0615CE2J0H
Q954	TCLT009450	TRANSISTOR, SILICON 2SC945A(C)-T	VR601	V126313B01	VR, SEMIFIXED RH0615C13J0F
Q955	TCLT009450	TRANSISTOR, SILICON 2SC945A(C)-T	VR602	V1263H4B01	VR, SEMIFIXED RH0615CJ4J0D
Q956	TCLT009450	TRANSISTOR, SILICON 2SC945A(C)-T	VR603	V1263H4B01	VR, SEMIFIXED RH0615CJ4J0D
Q957	TCLT009450	TRANSISTOR, SILICON 2SC945A(C)-T	VR701	V1263H4B01	VR, SEMIFIXED RH0615CJ4J0D
Q958	TCLT009450	TRANSISTOR, SILICON 2SC945A(C)-T	VR801	V175C53B01	VR, SEMIFIXED RVA0911H304-1-502M
Q959	TCLT009450	TRANSISTOR, SILICON 2SC945A(C)-T	VR802	V175C52B01	VR, SEMIFIXED RVA0911H304-1-501M
Q960	TCLT009450	TRANSISTOR, SILICON 2SC945A(C)-T	VR804	V175C53B03	VR, SEMIFIXED RVA0911H304-3-502M
Q961	TCLT009450	TRANSISTOR, SILICON 2SC945A(C)-T	VR805	V175C52B03	VR, SEMIFIXED RVA0911H304-3-501M
Q962	TCLT009450	TRANSISTOR, SILICON 2SC945A(C)-T	- P.C. BOARDS ASS'Y -		
Q963	TCLT009450	TRANSISTOR, SILICON 2SC945A(C)-T	PCB001	A37402A01AP	PCB ASS'Y TM0151-P
L201	03360N001C	COIL, DET 360N001	PCB002	A37402A11A	PCB ASS'Y TC0117
L202	021Z73680K	COIL EL0606RA-680K 68 UH Q=50	PCB003	A37402A03A	PCB ASS'Y TE0529
L203	021JA6R68M	COIL LAL02TAR68M 0.66 UH	PCB004	A37402A07A	PCB ASS'Y TE0532
L204	033605003C	COIL, MATCHING 3605003	PCB005	A37402A02A	PCB ASS'Y TE0531
L205	021JA6820K	COIL LAL02TA820K 82 UH	PCB006	A37402A02A	PCB ASS'Y TE0488
L206	021Z73680K	COIL EL0606RA-680K 68 UH Q=50	PCB007	A37402A15A	PCB ASS'Y TE0533
L207	021JA6100K	COIL LAL02TA100K 10 UH	PCB008	A37402A34A	PCB ASS'Y TE0536
L208	033602013C	COIL, AFT 3602013	PCB009	A37402A13A	PCB ASS'Y TE0530
L209	021JA6101K	COIL LAL02TA101K 100 UH	PCB010	A37402A31A	PCB ASS'Y TE0528
L210	033601002C	COIL, DET 3601002	- MISCELLANEOUS -		
L211	03360L001C	COIL, TRAP 360L001	B401	0246451652	CORE, BEADS BF25-4.5*5*1.6
L301	03361M002C	COIL, SIF 361M002	B402	0246451652	CORE, BEADS BF25-4.5*5*1.6
L302	03361M002C	COIL, SIF 361M002	B502	024JT03551	CORE, BEADS FBA04HA450AB-00
L303	021Z73101K	COIL EL0606RA-101K 100 UH Q=45	B503	024JT03551	CORE, BEADS FBA04HA450AB-00
L401	021679472K	COIL EL0909RR-472K 4.7 MH	B504	024JT03551	CORE, BEADS FBA04HA450AB-00
L402	0221000012	COIL, LINEARITY 21000012	B505	024JT03551	CORE, BEADS FBA04HA450AB-00
△ L501	0290000001	COIL, LINE FILTER RB-20871			
△ L502	0290000001	COIL, LINE FILTER RB-20871			

ELECTRICAL REPLACEMENT PARTS LIST

REF. NO	PART. NO	DESCRIPTION	
-MISCELLANEOUS (CONT)-			
B506	024JT03551	CORE, BEADS	FBA04HA450A8-00
BT101	141T003004	BATTERY, MANGAN	UM-3 1.5V
BT102	141T003004	BATTERY, MANGAN	UM-3 1.5V
CD101	0694250080	CONNECTOR PCB SIDE	174074-5
CD102	0694250080	CONNECTOR PCB SIDE	174074-5
CD109	068D24016A	CORD, CONNECTOR	8D24016A
CD110	068D28014A	CORD, CONNECTOR	8D28014A
CD111	068D26018A	CORD, CONNECTOR	8D26018A
CD112	068D12304A	CORD, CONNECTOR	8D12304A
CD113	068D12303A	CORD, CONNECTOR	8D12303A
CD351	068D14204A	CORD, CONNECTOR	8D14204A
CD352	068D43020A	CORD, CONNECTOR	8D43020A
CD401	068D34008A	CORD, EIS CONNECTOR	8D34008
△ CD501	120S450023	CORD, AC	120S450023
CD502	068D16071A	CORD, CONNECTOR	8D16071A
CD503	068D12301A	CORD, CONNECTOR	8D12301A
CD504	068D43019A	CORD, CONNECTOR	8D43019A
CD505	068D32045A	CORD, CONNECTOR	8D32045A
CD507	068D01282A	CORD, CONNECTOR	8D01282A
CD508	068D44006A	CORD, CONNECTOR	8D44006A
CD801	122N054005	CORD, JUMPER	2N054005
CD802	122N044003	CORD, JUMPER	2N044003
CD803	068D01201A	CORD, CONNECTOR	8D01201A
CF001	116F3TH4Z1	FILTER, EMI	LTSTF223ZBTB
CF002	116F3TH4Z1	FILTER, EMI	LTSTF223ZBTB
CF003	116F3TH4Z1	FILTER, EMI	LTSTF223ZBTB
CF004	116F3TH4Z1	FILTER, EMI	LTSTF223ZBTB
CF101	10034R0001	CERAMIC, OSCILLATOR	KBR-4.0M
CF201	1027038R95	FILTER, SAW	F1037B
CF202	1012T5R503	FILTER, CERAMIC TRAP	TPS5.5MB-TF20
CF301	101205R503	FILTER, CERAMIC	CDA5.5MC29
CF302	1012005R52	FILTER, CERAMIC	SFE5.5MC2
CF351	116F3TH4Z1	FILTER, EMI	LTSTF223ZBTB
CF352	116F3TH4Z1	FILTER, EMI	LTSTF223ZBTB
CF701	101225R741	FILTER, CERAMIC DIS.	CDA5R74MC10
CF702	101205R742	FILTER, CERAMIC	SFE5.74MC2
CF703	101205R741	FILTER, CERAMIC	SFE5.74MC
CP101	0694250100	CONNECTOR PCB SIDE	174075-5
CP102	0694250100	CONNECTOR PCB SIDE	174075-5
CP103	069H180209	CONNECTOR PCB SIDE	1LG8P-S3L-PCB-S
CP104	069Q180179	CONNECTOR PCB SIDE	CPB1808-0101
CP105	069H160209	CONNECTOR PCB SIDE	1LG6P-S3L-PCB-S
CP109	069D240119	CONNECTOR PCB SIDE	B 4B-PH
CP110	069D280119	CONNECTOR PCB SIDE	B 8B-PH
CP111	069D260119	CONNECTOR PCB SIDE	B 6B-PH
CP351	0694140019	CONNECTOR PCB SIDE	171825-4
CP352	069D430029	CONNECTOR PCB SIDE	TV-50P-03-A1
CP401	069D340018	CONNECTOR PCB SIDE	TS-80P-04-V1
CP502	0694160019	CONNECTOR PCB SIDE	171825-6
CP503	0694120019	CONNECTOR PCB SIDE	171825-2
CP504	069D330018	CONNECTOR PCB SIDE	TS-80P-03-V1
CP505	069D320018	CONNECTOR PCB SIDE	TS-80P-02-V1
CP506	069D320029	CONNECTOR PCB SIDE	TV-50P-02-V1
CP507	069D01001A	CONNECTOR PCB SIDE	003P-2100
CP508	069D440019	CONNECTOR PCB SIDE	TV-50P-04-A1
CP803	069D010010	CONNECTOR PCB SIDE	005P-2100
CP851	069Q180179	CONNECTOR PCB SIDE	CPB1808-0101
CP852	069H170209	CONNECTOR PCB SIDE	1LG7P-S3L-PCB-S
CV501	12AL10002A	COVER, AC CORD	SB-1235B-U09
DL601	104114R43G	DELAY LINE GLASS	EFDEN645A31F
DL602	103S000402	DELAY LINE	ELT10Z204M
△ F501	0808T2R502	FUSE	T 2.5A 250V
△ FB401	0432200162	TRANSFORMER, FLYBACK	3220016
FH501	067M0T0004	HOLDER, FUSE	H0451
FH502	067M0T0005	HOLDER, FUSE	H0452
MS501	128B000017	MICA, SHEET	STR-50103MICA
NR101	110E547301	R, NETWORK	RN3H6A473J01
OS101	077M006004	REMOTE RECEIVER	KEY-C00SV2
SP351	070A146004	SPEAKER	CS10T4479-N
SP352	070A146004	SPEAKER	CS10T4479-N
TC851	0100514001	C, CERAMIC TRIMMER	TZ03R300E
TH501	D810M180H0	DEGAUSS ELEMENT	ERP-F580M180H
TM101	076100Q003	TRANSMITTER	EUR-53855
△ TU001	0145211006	TUNER, UHF-VHF	EC-CB-0309-(A)
V801	09BE210403	TUBE, CATHODE RAY	A51EBD10X61
X251	1003R50001	CERAMIC, OSCILLATOR	KBR-500AH2
X401	1002R50301	CERAMIC, OSCILLATOR	CSB503F2
X601	10054R4301	CRYSTAL NR-18	4.433619MHZ
X850	100613R801	CRYSTAL	HC49/U 13.875MHZ
X851	10026R0004	SERALOCK	CSA6.00MT

RESISTOR
RC.....CARBON RESISTOR

CAPACITORS
CC.....CERAMIC CAPACITOR
CE.....ALUMI ELECTROLYTIC CAPACITOR
CP.....POLYESTER CAPACITOR
CPP.....POLYPROPYLENE CAPACITOR
CPL.....PLASTIC CAPACITOR
CMP.....METAL POLYESTER CAPACITOR
CMPL.....METAL PLASTIC CAPACITOR
CMPP.....METAL POLYPROPYLENE CAPACITOR
CST.....STYROL CAPACITOR

INTERCHANGEABLE PARTS LIST

NOTE: THE FOLLOWING PART(S) MAY BE SUBSTITUTED FOR PARTS INDICATED IN THE BASIC PART(S) LIST (WITH THE SAME REF. NO.). THESE PARTS SHARE THE SAME ELECTRICAL CHARACTERISTICS AND OTHER ELEMENTS FOR COMMON USAGE. EITHER PART NUMBER MAY BE USED IN THIS UNIT.

REF. NO	DESCRIPTION (PART NO)	DESCRIPTION (PART NO)
Q107	DTC144ESTP (TN7TD03001)	BA1L4M-T (TNLTD03001)
Q110	DTC144ESTP (TN7TD03001)	BA1L4M-T (TNLTD03001)
Q112	DTC144ESTP (TN7TD03001)	BA1L4M-T (TNLTD03001)
Q117	DTC144ESTP (TN7TD03001)	BA1L4M-T (TNLTD03001)

THE PARTS LISTED ARE INTERCHANGEABLE BY ONE COMPLETE BLOCK.

REF. NO	DESCRIPTION (PART NO)	DESCRIPTION (PART NO)
TU001	EC-CB-0309-(A) (0145211006)	EC-CB-0309 (0145211003)
J001		HXC0242-01-110 (0632200019)