

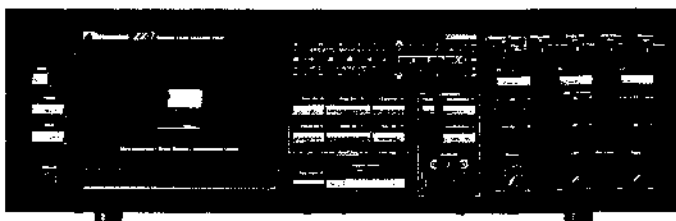

Service Manual

Nakamichi ZX-7

Discrete Head Cassette Deck





CONTENTS

1. General	3
2. Removal Procedures	4
2. 1. Top Cover Ass'y	4
2. 2. Bottom Cover Ass'y	4
2. 3. Cassette Case Cover Ass'y	4
2. 4. Front Panel Ass'y	5
2. 5. Mechanism Ass'y	5
2. 6. Logic & Power P.C.B. Ass'y	6
2. 7. Dolby NR P.C.B. Ass'y	6
2. 8. Azimuth Switch P.C.B. Ass'y	6
2. 9. Power Switch P.C.B. Ass'y	6
2. 10. Headphone Jack Ass'y	6
2. 11. Record Cal. P.C.B. Ass'y	7
2. 12. Sub Chassis Ass'y	7
2. 13. Switch P.C.B. Ass'y and Volume P.C.B. Ass'y	7
2. 14. Main P.C.B. Ass'y	7
2. 15. Record Cal. LED P.C.B. Ass'y, Control Switch P.C.B. Ass'y, Indicator P.C.B. Ass'y, Counter P.C.B. Ass'y and Counter Control P.C.B. Ass'y	7
2. 16. Rear Panel Ass'y and Power Transformer	8
2. 17. Cassette Case Plate Ass'y, Cassette Case Ass'y and Cover Plate Ass'y	9
2. 18. Capstan Motor Ass'y and Flywheel Ass'y	9
2. 19. Sub Mechanism Chassis Ass'y	9
2. 20. Control Motor Ass'y and Reel Motor Ass'y	9
2. 21. Cam Control Volume	9
2. 22. Reel Hub Ass'y and Idler Ass'y	9
2. 23. Cam Drive Gear and Control Cam	10
2. 24. Head Mount Base Ass'y	11
2. 25. Erase Head, Pressure Roller and Tape Guide	11
2. 26. Playback Head Ass'y and Record Head Ass'y	11
3. Measurement Instruments	12
4. Mechanical Adjustments	12
4. 1. Mechanism Control Cam Adjustment	12
4. 2. Reel Motor Speed Adjustment in Play Mode	13
4. 3. Record Head and Playback Head Tilt Adjustment	13
4. 4. Head Base Stroke Adjustment	15
4. 5. Erase Head Stroke Adjustment and Tape Guide Height Check	15
4. 6. Erase Head Height and Tilt Adjustment	16
4. 7. Back Tension Adjustment	17
4. 8. Playback Head and Record Head Height Adjustment and Azimuth Alignment	17
4. 9. Record Head Stroke Adjustment	19
4. 10. Tape Travelling Adjustment	20
4. 11. Flywheel Holder Adjustment	20
4. 12. Tape Speed Adjustment	20
4. 13. Lubrication	20
5. Parts Location for Electrical Adjustment	21
6. Electrical Adjustments and Measurements	22
6. 1. Adjustment and Measurement Instructions	22
6. 2. Frequency Response Adjustment	26
6. 3. Dolby NR Circuit Check	27
7. Mounting Diagrams and Parts List	28
7. 1. Power Switch P.C.B. Ass'y	28
7. 2. Azimuth Switch P.C.B. Ass'y	28
7. 3. Record Cal. LED P.C.B. Ass'y	28
7. 4. Volume P.C.B. Ass'y	28
7. 5. Counter P.C.B. Ass'y	28
7. 6. Counter Control P.C.B. Ass'y	28

7. 7.	Shut-off P.C.B. Ass'y	28
7. 8.	Indicator P.C.B. Ass'y	28
7. 9.	Control Switch P.C.B. Ass'y	29
7. 10.	Record Cal. P.C.B. Ass'y	29
7. 11.	Switch P.C.B. Ass'y	30
7. 12.	Dolby NR P.C.B. Ass'y	31
7. 13.	Logic & Power P.C.B. Ass'y	39
7. 14.	Main P.C.B. Ass'y	43
8.	Mechanism Ass'y and Parts List	49
8. 1.	Synthesis	49
8. 2.	Front Panel Ass'y (A01)	49
8. 3.	Chassis Ass'y (A02)	52
8. 4.	Front Escutcheon A Ass'y (B01)	53
8. 5.	Control House Ass'y (B02)	53
8. 6.	Front Escutcheon B Ass'y (B03)	53
8. 7.	Headphone Holder Ass'y (C01)	53
8. 8.	Mechanism Ass'y ZX-7 (C02)	54
8. 9.	Rear Panel Ass'y (C03)	56
8. 10.	Flywheel Holder Ass'y (D01)	56
8. 11.	Sub Mechanism Chassis Ass'y (D02)	56
8. 12.	Main Mechanism Chassis Ass'y (D03)	57
8. 13.	Capstan Motor Ass'y (E01)	58
8. 14.	Reel Motor Ass'y (F01)	58
8. 15.	Control Motor Ass'y (F02)	58
8. 16.	Head Mount Base Ass'y (G01)	58
8. 17.	Supply Pressure Roller Ass'y (G02)	58
8. 18.	Take-up Pressure Roller Ass'y (G03)	58
8. 19.	Head Base Ass'y (G04)	59
8. 20.	Cassette Case Holder L Ass'y (G05)	59
8. 21.	Cassette Case Holder R Ass'y (G06)	59
8. 22.	Auto Shut-off Ass'y (G07)	59
8. 23.	Pneumatic Damper Ass'y (G08)	59
8. 24.	P-8L Playback Head Ass'y (H01)	59
8. 25.	R-8L Record Head Ass'y (H02)	59
9.	Overall Timing Chart	60
10.	Eq. Amp. Frequency Response	60
10. 1.	Playback Frequency Response	60
10. 2.	Record Current Frequency Response	60
11.	Block Diagrams	61
11. 1.	Amplifier Section	61
11. 2.	Mechanism Control Section	62
12.	Wiring Diagram	63
13.	Schematic Diagrams	65
13. 1.	Amplifier Section	65
13. 2.	Dolby NR Section	66
13. 3.	Mechanism Control Section	68
13. 4.	Attention to Servicemen	69
13. 5.	IC Block Diagrams	69
14.	Specifications	70

1. GENERAL

1.1. Control Functions

The Nakamichi ZX-7 control functions are shown below:

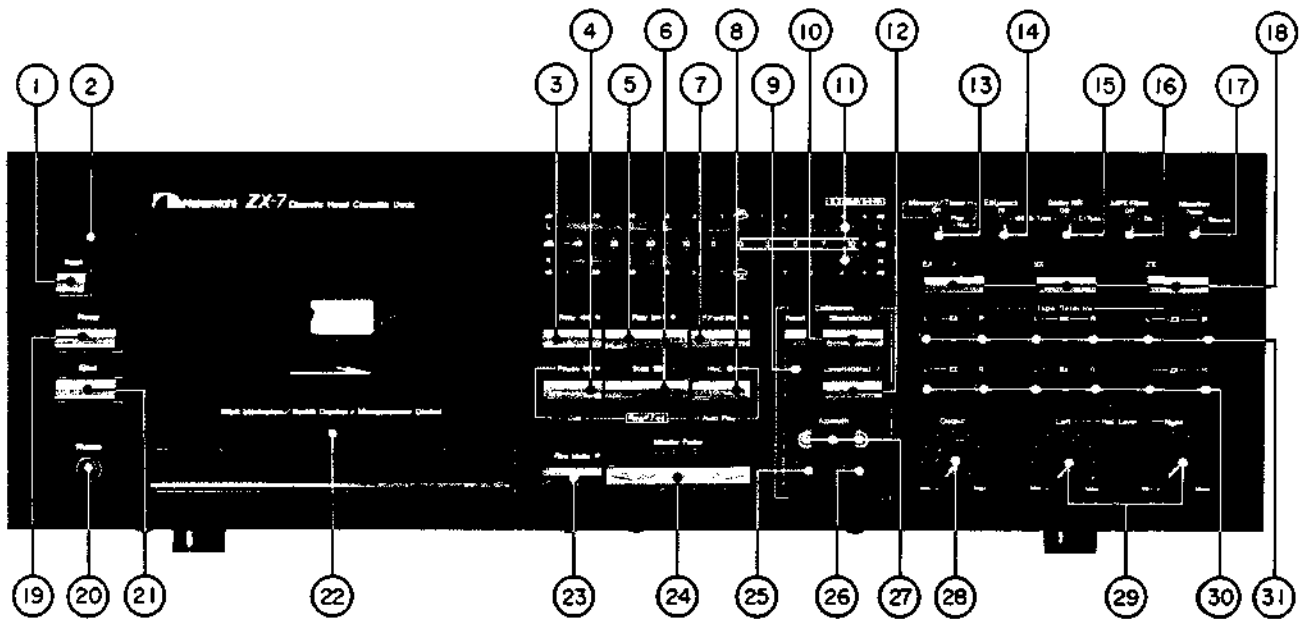

Fig. 1.1 Front View

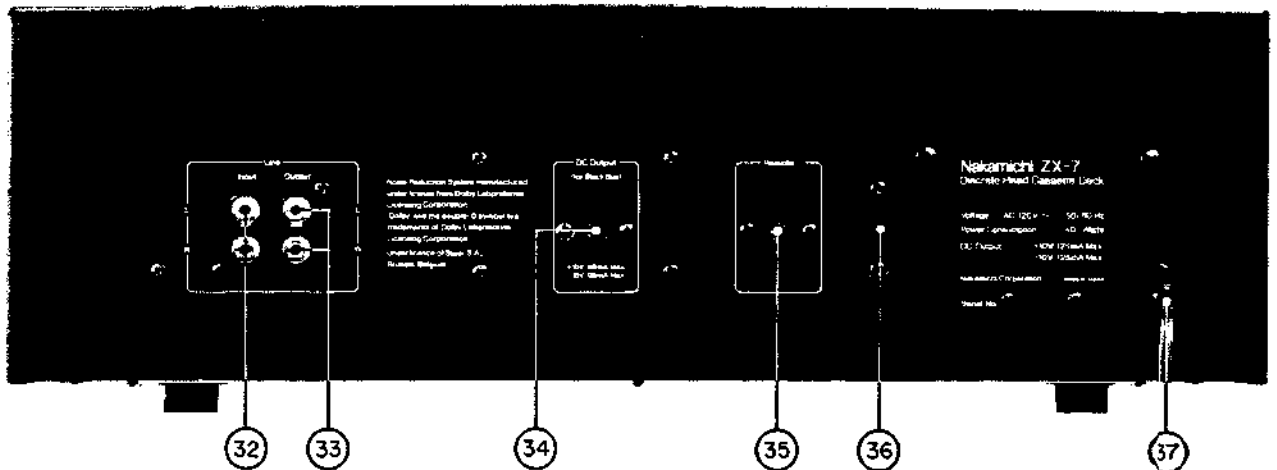

Fig. 1.2 Rear View

- | | | |
|------------------------------------|------------------------------------|--------------------------|
| 1. Counter Reset Button | 14. Eq. Switch | 27. Azimuth Indicators |
| 2. Tape Counter | 15. Dolby NR Switch | 28. Output Level Control |
| 3. Rewind Button | 16. MPX Filter Switch | 29. Input Level Controls |
| 4. Pause Button | 17. Monitor Switch | 30. Sensitivity Controls |
| 5. Play Button | 18. Tape Selector Buttons | 31. Bias Controls |
| 6. Stop Button | 19. Power Switch | 32. Input Jacks |
| 7. Fast-Forward Button | 20. Headphone Jack | 33. Output Jacks |
| 8. Record Button | 21. Eject Button | 34. DC Output Jack |
| 9. Calibration Reset Button | 22. Cassette Holder | 35. Remote Control Jack |
| 10. Bias Calibration Start Button | 23. Rec. Mute Button | 36. Voltage Selector |
| 11. Peak Level Meters | 24. Master Fader Control | 37. Power Cord |
| 12. Level Calibration Start Button | 25. Azimuth Alignment Start Button | |
| 13. Tape Start Memory/Timer Switch | 26. Azimuth Alignment Knob | |

1.2. Voltage Selector

Voltage selector is installed on the rear panel for Other Version of the Nakamichi ZX-7.
This voltage selector can select either 120 V or 220-240 V at customer's disposal.

2. REMOVAL PROCEDURES

2.1. Top Cover Ass'y

Refer to Fig. 2.1.

- (1) Remove F01 and F02, then disassemble F03 (Top Cover Ass'y).

2.2. Bottom Cover Ass'y

Refer to Fig. 2.1.

- (1) Remove F04, then disassemble F05 (Bottom Cover Ass'y).

2.3. Cassette Case Cover Ass'y

Refer to Fig. 2.1.

- (1) Press the Eject Button to open Cassette Case Ass'y.
- (2) Pull out F06 (Cassette Case Cover Ass'y) upwardly.
- (3) Pull out F07 (Cal. Volume Cap).

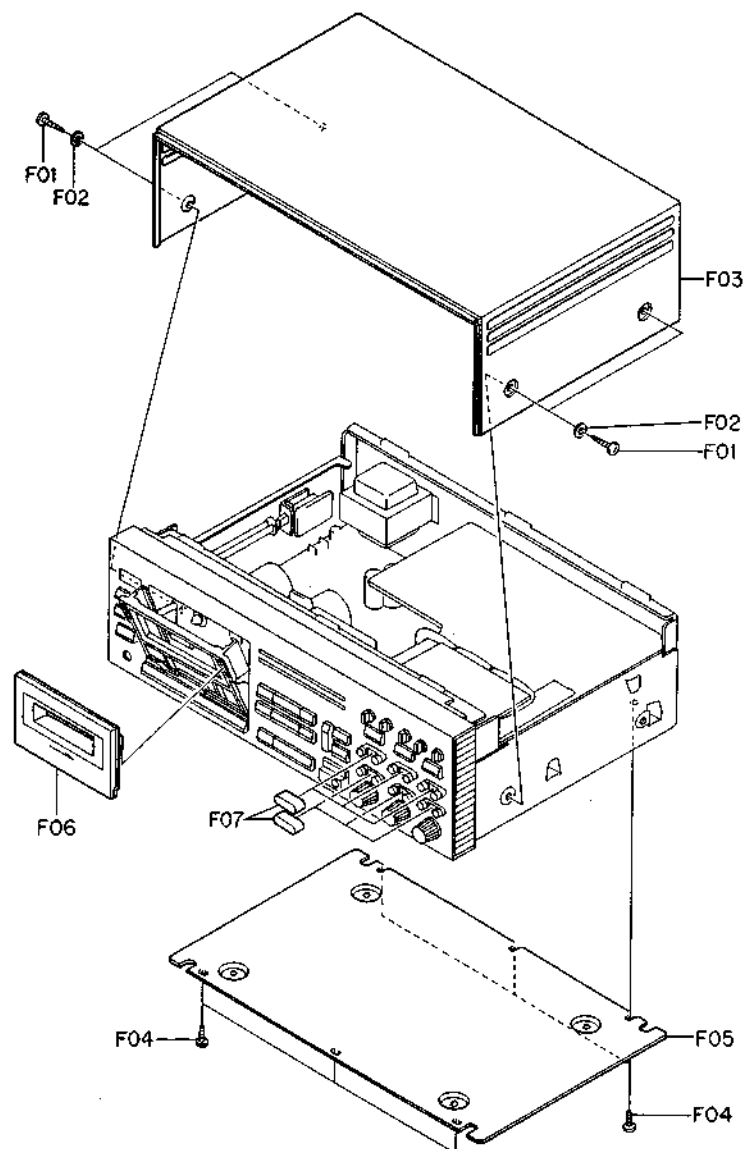
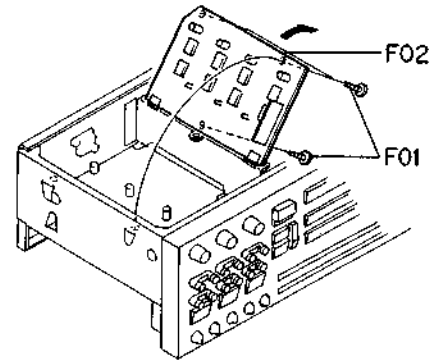

Fig. 2.1

2.4. Front Panel Ass'y

Refer to Fig. 2.2.

- (1) Refer to Fig. 2.1. Remove Top Cover Ass'y and Bottom Cover Ass'y referring to items 2.1 and 2.2.
- (2) Refer to bottom view (A). Remove F01, then turn F02 (Dolby NR P.C.B. Ass'y) over as an arrow head.
- (3) Pull out F03 (Function Switch Knob), F04 (Cal. Volume Knob) and F05 (Volume Knob).
- (4) Remove F06 and F07 (Azimuth Wire), then disassemble F08 (Front Panel Ass'y including 11 connectors).



(A) Bottom View

2.5. Mechanism Ass'y

Refer to Fig. 2.2.

- (1) Remove Front Panel Ass'y referring to item 2.4.
- (2) Remove F09 (Power Switch Joint Bar) by releasing the self-interlocking pin of Power Switch Joint Bar from Power Switch P.C.B. Ass'y.
- (3) Remove F10, F11 and F12, then disassemble F13 (Mechanism Ass'y including 5 connectors).

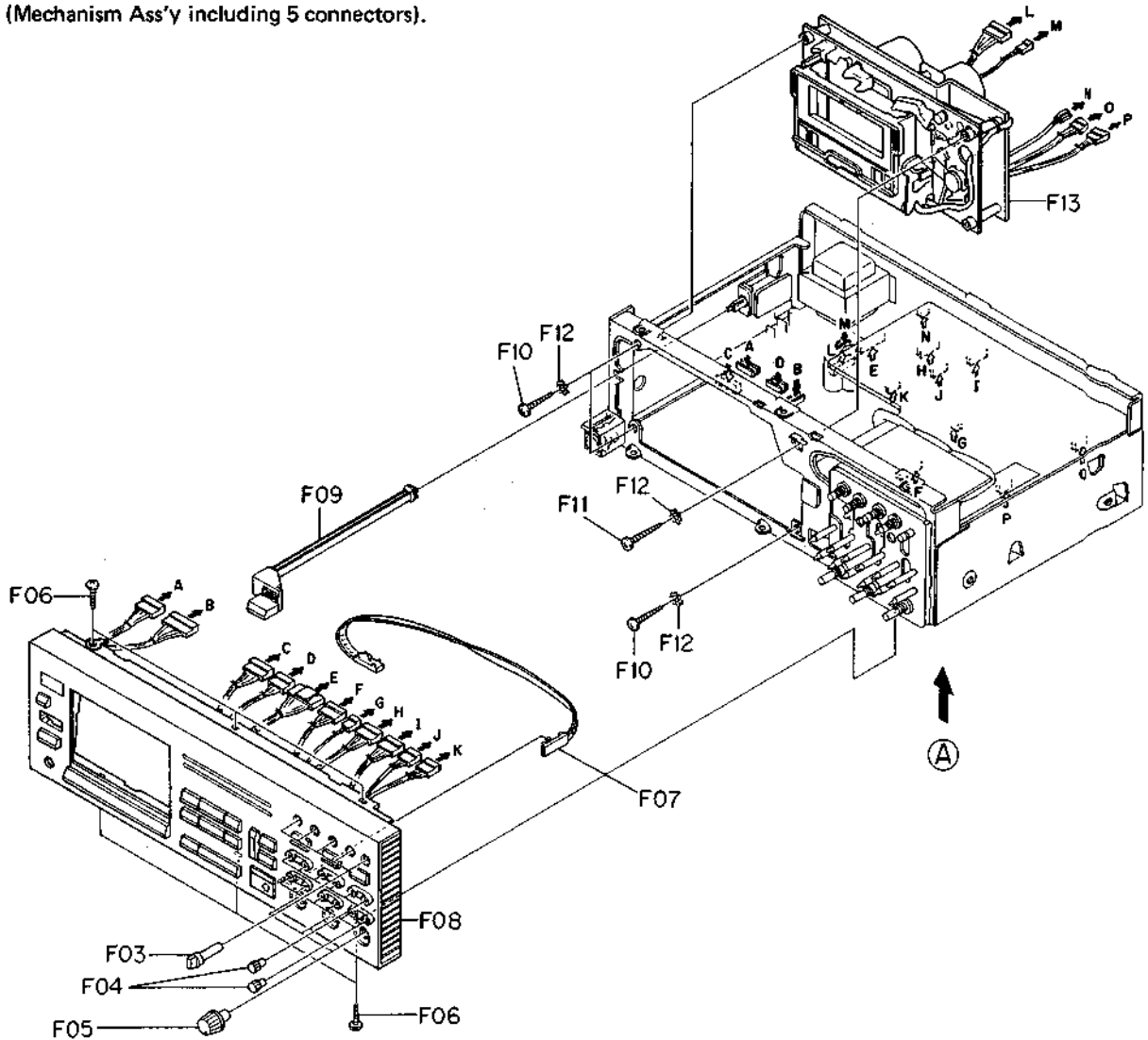

Fig. 2.2

2.6. Logic & Power P.C.B. Ass'y

Refer to Fig. 2.3.

- (1) Refer to Fig. 2.1. Remove Top Cover Ass'y and Bottom Cover Ass'y referring to items 2.1 and 2.2.
- (2) Remove 6 connectors and the wires connected by wrapping from F03 (Logic & Power P.C.B. Ass'y).
- (3) Remove F01 and F02, then disassemble F03 (Logic & Power P.C.B. Ass'y).

2.7. Dolby NR P.C.B. Ass'y

Refer to Fig. 2.3.

- (1) Refer to Fig. 2.1. Remove Top Cover Ass'y and Bottom Cover Ass'y referring to items 2.1 and 2.2.
- (2) Remove the wires connected by wrapping from F05 (Dolby NR P.C.B. Ass'y).
- (3) Remove F04, then disassemble F05 (Dolby NR P.C.B. Ass'y) by releasing the self-interlocking pin of P.C.B. Supporters.

2.8. Azimuth Switch P.C.B. Ass'y

Refer to Fig. 2.3.

- (1) Refer to Fig. 2.2. Remove Front Panel Ass'y referring to item 2.4.

- (2) Remove F06, then disassemble F07 (Azimuth Switch P.C.B. Ass'y).

2.9. Power Switch P.C.B. Ass'y

Refer to Fig. 2.3.

- (1) Refer to Fig. 2.2. Remove Front Panel Ass'y referring to item 2.4.
- (2) Remove F08 (Power Switch Joint Bar) by releasing the self-interlocking pin of Power Switch Joint Bar from Power Switch P.C.B. Ass'y.
- (3) Remove F09, then disassemble F10 (Power Switch P.C.B. Ass'y).

2.10. Headphone Jack Ass'y

Refer to Fig. 2.3.

- (1) Refer to Fig. 2.2. Remove Front Panel Ass'y referring to item 2.4.
- (2) Remove F11 and F12, then disassemble F13 (Headphone Jack Ass'y).
- (3) Remove F14 and F15, then disassemble F16 (Headphone Jack).

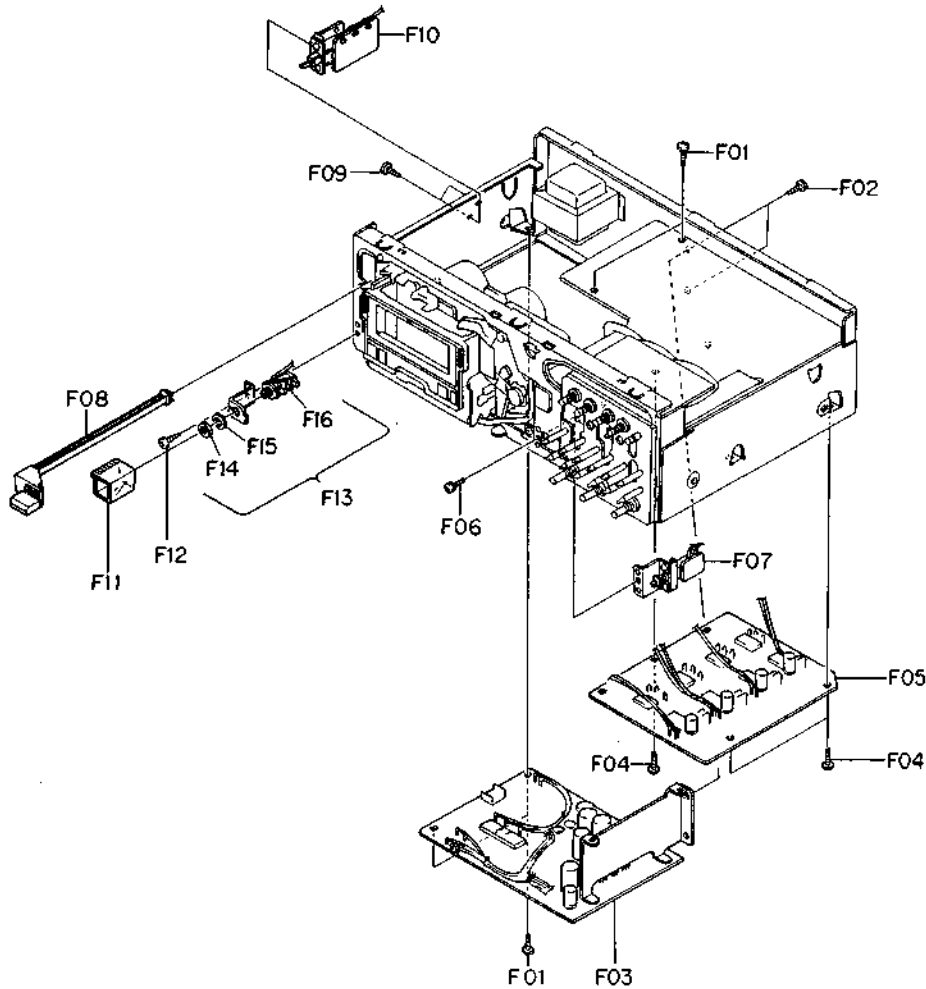

Fig. 2.3

2.11. Record Cal. P.C.B. Ass'y

Refer to Fig. 2.4.

- (1) Refer to Fig. 2.2. Remove Front Panel Ass'y referring to item 2.4.
- (2) Remove F01 and F02, then disconnect F03 (Record Cal. P.C.B. Ass'y including one connector) from F17 (Main P.C.B. Ass'y).

2.12. Sub Chassis Ass'y

Refer to Fig. 2.4.

- (1) Refer to Fig. 2.2. Remove Front Panel Ass'y referring to item 2.4.
- (2) Remove F04, then disassemble F05 (Sub Chassis Ass'y).

2.13. Switch P.C.B. Ass'y and Volume P.C.B. Ass'y

Refer to Fig. 2.4.

- (1) Remove Sub Chassis Ass'y referring to item 2.12.
- (2) Remove F06, F07, F08, F09 and F10, then disassemble F11 (Switch P.C.B. Ass'y).
- (3) Remove F12 and F13, then disassemble F14 (Volume P.C.B. Ass'y).

2.14. Main P.C.B. Ass'y

Refer to Fig. 2.4.

- (1) Remove Sub Chassis Ass'y referring to item 2.12.
- (2) Remove F15 and F16, then disassemble F17 (Main P.C.B. Ass'y).

2.15. Record Cal. LED P.C.B. Ass'y, Control Switch P.C.B. Ass'y, Indicator P.C.B. Ass'y, Counter P.C.B. Ass'y and Counter Control P.C.B. Ass'y

Refer to Fig. 2.5.

- (1) Refer to Fig. 2.2. Remove Front Panel Ass'y referring to item 2.4.
- (2) Remove F01, then disassemble F02 (Record Cal. LED P.C.B. Ass'y).
- (3) Remove F03, then disassemble F04 (Shield Case).
- (4) Remove F05 and F06, then disassemble F07 (Indicator P.C.B. Ass'y).
- (5) Remove F08, then disassemble F09 (Control Switch P.C.B. Ass'y).

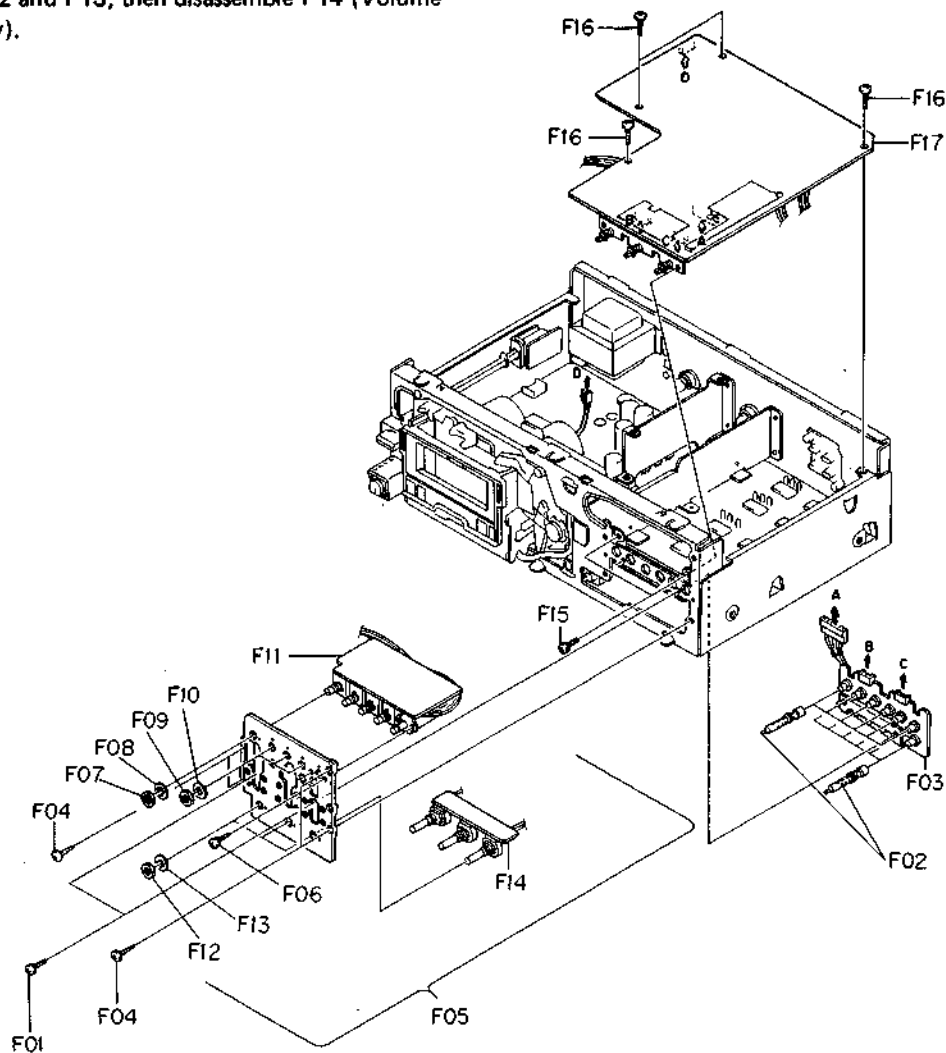

Fig. 2.4

- (6) Remove F10, then disassemble F11 (Shield Case).
- (7) Remove F12 and F13, then disassemble F14 (Counter P.C.B. Ass'y and Counter Control P.C.B. Ass'y).

2.16. Rear Panel Ass'y and Power Transformer
Refer to Fig. 2.6.

- (1) Refer to Fig. 2.1. Remove Top Cover Ass'y and Bottom Cover Ass'y referring to items 2.1 and 2.2.
- (2) Remove F01 and F02, then disassemble F03 (Rear Panel Ass'y).
- (3) Remove F04 and F05, then disassemble F06 (Power Transformer).

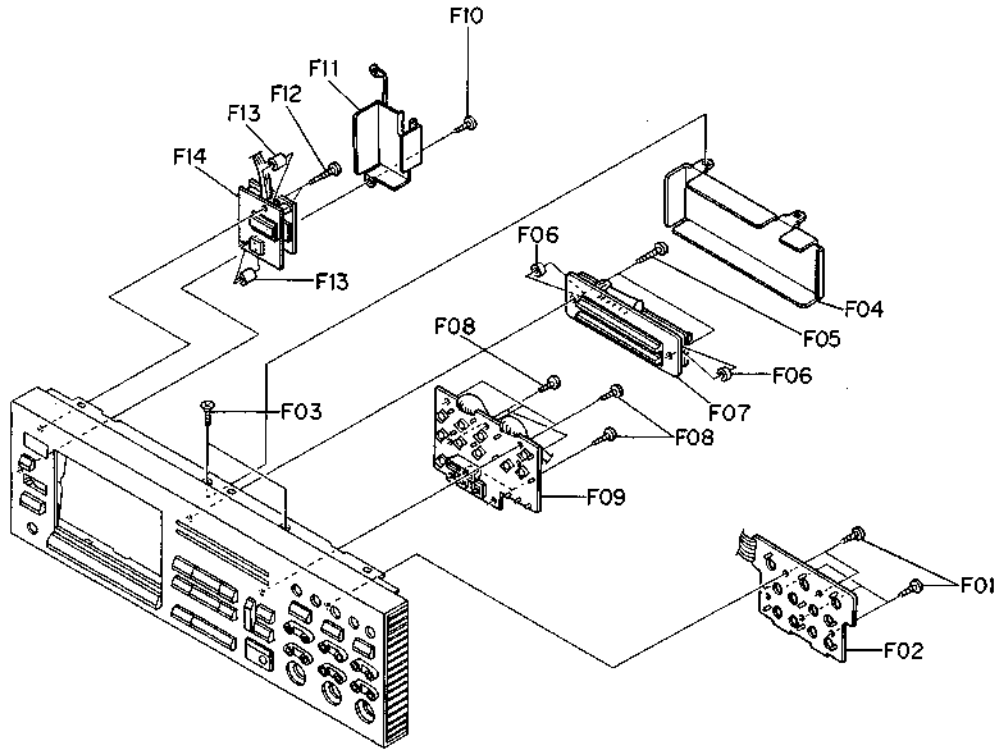

Fig. 2.5

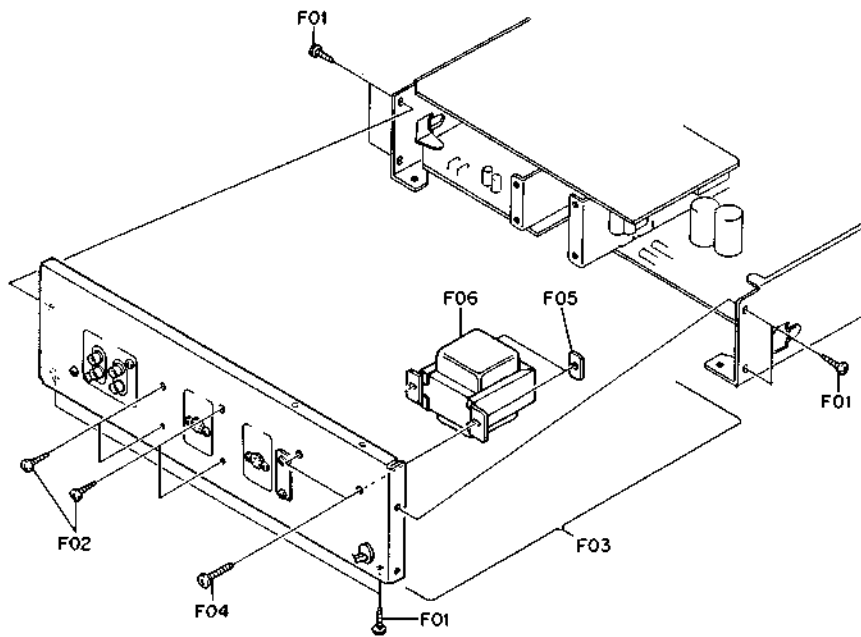

Fig. 2.6

2.17. Cassette Case Plate Ass'y, Cassette Case Ass'y and Cover Plate Ass'y

Refer to Fig. 2.7.

- (1) Refer to Fig. 2.2. Remove Mechanism Ass'y referring to item 2.5.
- (2) Remove F01, then disassemble F02 (Cassette Case Plate Ass'y).
- (3) Remove F03 (Cassette Case Lamp) from Cassette Case Plate, then pull out F04 (Lamp P.C.B.) from F08 (Cassette Case Ass'y).
- (4) Remove F05 and F06, then disassemble F07 (Cassette Case Holder L Ass'y) by releasing the self-interlocking pin of Damper Lock Arm and F08 (Cassette Case Ass'y).
- (5) Remove F09, then disassemble F10 (Cover Plate Ass'y).

2.18. Capstan Motor Ass'y and Flywheel Ass'y

Refer to Fig. 2.8.

- (1) Refer to Fig. 2.2. Remove Mechanism Ass'y referring to item 2.5.
- (2) Remove F01, F02 and F03, then disassemble F04 (Flywheel Holder Ass'y) and F05 (Capstan Belt).
- (3) Remove F06, then disassemble F07 (Capstan Motor Ass'y).
- (4) Remove F08 (Supply Flywheel Ass'y), then disassemble F09 (Take-up Flywheel Ass'y).
- (5) After removing both Flywheel Assemblies, disassemble F10 (Thrust Washer 3mm), F11 (Thrust Washer 2.6mm), F12 (Flange Thrust Cap) and F13 (Flange Thrust Spring).

2.19. Sub Mechanism Chassis Ass'y

Refer to Fig. 2.9.

- (1) Refer to Fig. 2.8. Remove Flywheel Holder Ass'y referring to item 2.18.
- (2) Remove F01, F02 and F03, then disassemble F04 (Sub Mechanism Chassis Ass'y).

2.20. Control Motor Ass'y and Reel Motor Ass'y

Refer to Fig. 2.9.

- (1) Remove Sub Mechanism Chassis Ass'y referring to item 2.19.
- (2) Remove F05, then disassemble F06 (Control Motor Ass'y).
- (3) Remove F07, then disassemble F08 (Reel Motor Ass'y).

2.21. Cam Control Volume

Refer to Fig. 2.9.

- (1) Remove Sub Mechanism Chassis Ass'y referring to item 2.19.
- (2) Remove F09, then disassemble F10 (Volume Coupler).
- (3) Remove F11 and F12, then disassemble F13 (Cam Control Volume).

2.22. Reel Hub Ass'y and Idler Ass'y

Refer to Fig. 2.9.

- (1) Remove Sub Mechanism Chassis Ass'y referring to item 2.19.
- (2) Remove F14 (Reel Hub Head), then disassemble F15 (Reel Hub B Ass'y), F16 (Reel Hub Take-up Ass'y),

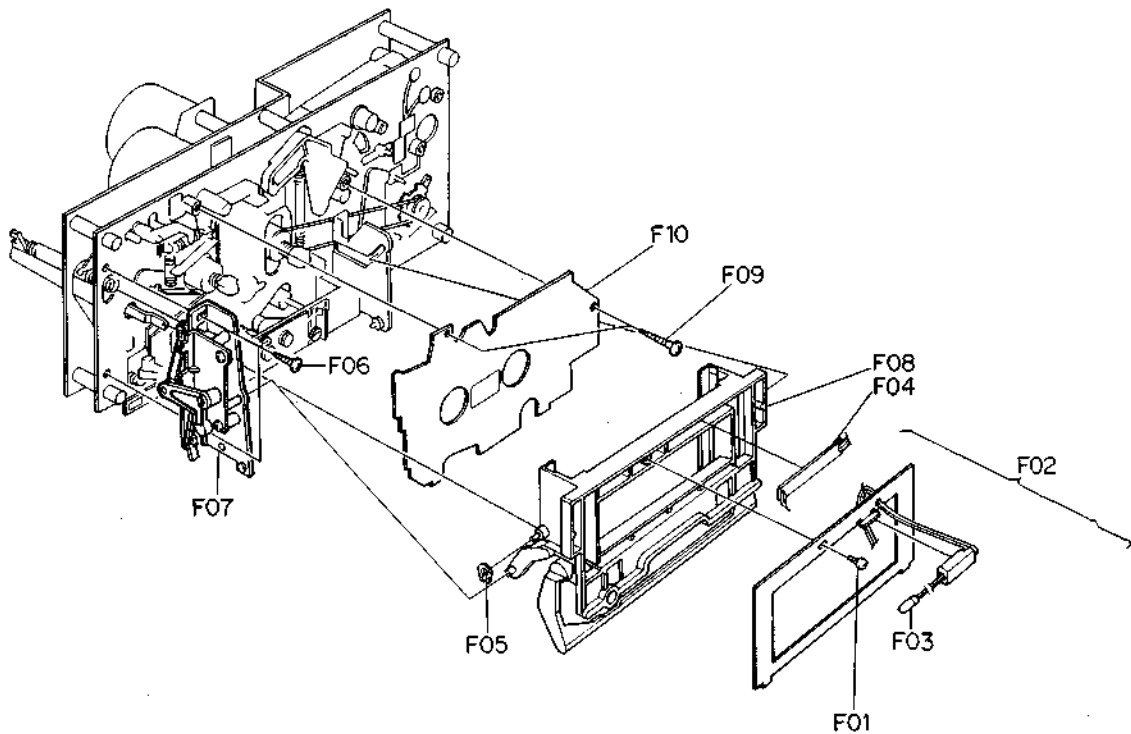

Fig. 2.7

- F17 (Reel Hub Supply Ass'y), F18 (Back Tension Ass'y) and F19 (Back Tension Spring).
- (3) Remove F20, then disassemble F21 (Idler Ass'y).

2.23. Cam Drive Gear and Control Cam

Refer to Fig. 2.9.

- (1) Remove Sub Mechanism Chassis Ass'y referring to

- item 2.19.
- (2) Remove F22, then disassemble F23 (Cam Drive Gear).
- (3) Remove F24, then disassemble F25 (Counter-Load Arm Ass'y).
- (4) Remove F26, then disassemble F27 (Control Cam).

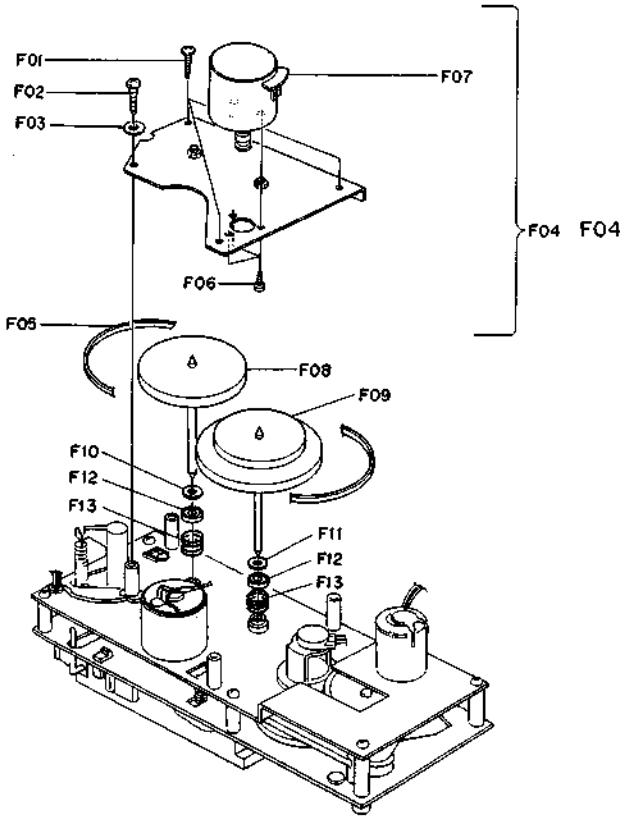

Fig. 2.8

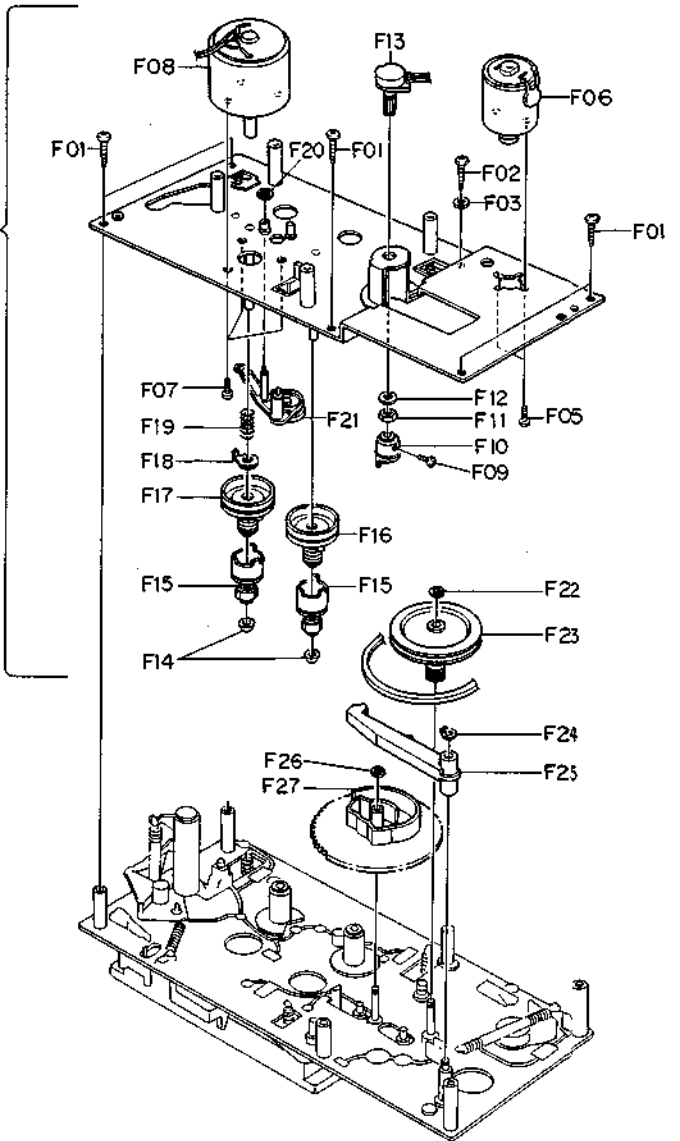

Fig. 2.9

2.24. Head Mount Base Ass'y

Refer to Fig. 2.10.

- (1) Refer to Fig. 2.7. Remove Cassette Case Ass'y referring to item 2.17.
- (2) Remove F01, then disassemble F02 (Head Mount Base Ass'y).

2.25. Erase Head, Pressure Roller and Tape Guide

Refer to Fig. 2.10.

- (1) Remove Head Mount Base Ass'y referring to item 2.24.
- (2) Remove F03, then disassemble F04 (Erase Head).
- (3) Remove F05, then disassemble F06 (Supply Pressure Roller).
- (4) Remove F07, then disassemble F08 (Supply Tape Guide).
- (5) Remove F09, then disassemble F10 (Take-up Pressure Roller).
- (6) Remove F11, then disassemble F12 (Take-up Tape Guide).

2.26. Playback Head Ass'y and Record Head Ass'y

Refer to Fig. 2.10.

- (1) Remove Head Mount Base Ass'y referring to item 2.24.
- (2) Turn F13 by 90° by pushing it, then disassemble F14 (Playback Head Ass'y).
- (3) Turn F15 by 90° by pushing it, then disassemble F16 (Record Head Ass'y) and F17 (RH Azimuth Alignment Plate).

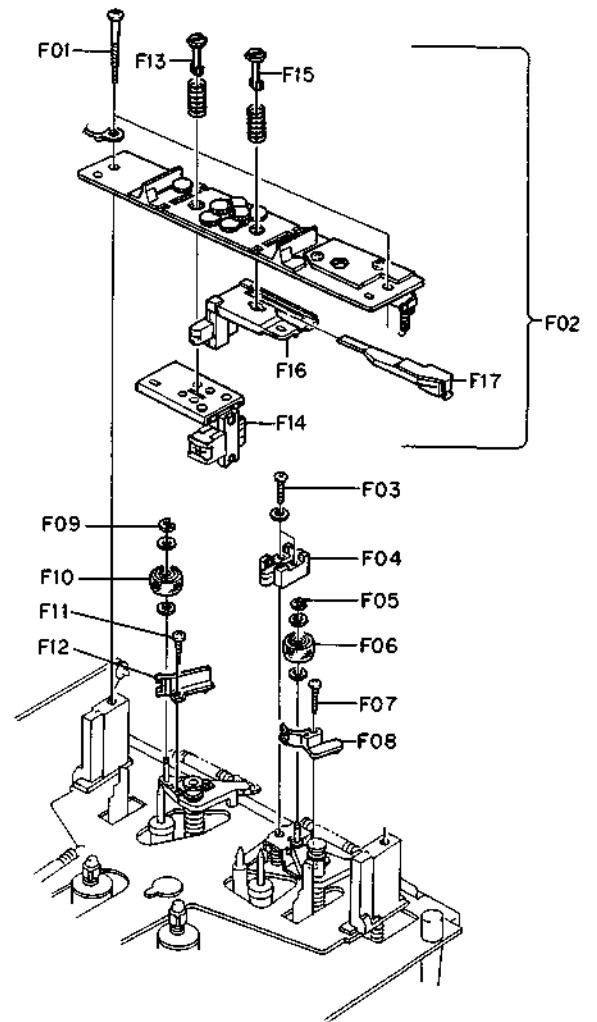

Fig. 2.10

3. MEASUREMENT INSTRUMENTS

- (1) Audio Generator (20 Hz – 200 kHz)
- (2) AC Millivolt Meter (with dB measures)
- (3) Oscilloscope (DC – 5 MHz)
- (4) Distortion Meter
- (5) Speed & Wow/Flutter Meter
- (6) Frequency Counter (DC – 1 MHz)
- (7) Ohm Meter
- (8) DC Volt Meter
- (9) AC Volt Meter
- (10) Torque Gauge (DA09013A)
- (11) 15 kHz Azimuth Tape (DA09004A)
- (12) 3 kHz Speed & Wow/Flutter Tape (DA09006A)
- (13) 1 kHz Track Alignment Tape (DA09007A)
- (14) 400 Hz Level Tape (DA09005A)
- (15) 20 kHz PB Frequency Response Tape (DA09001A)
- (16) 15 kHz PB Frequency Response Tape (DA09002A)
- (17) 10 kHz PB Frequency Response Tape (DA09003A)
- (18) Reference EXII Tape (DA09066A)
- (19) Reference SX Tape (DA09025A)
- (20) Reference ZX Tape (DA09037A)
- (21) Tilt Check Gauge M-9039 (DA09039A)
- (22) EH Tilt Check Gauge M-9040 (DA09040A)
- (23) EH Stroke Check Gauge M-9051 (DA09051A)
- (24) Stroke Check Gauge M-9047 (DA09047B)
- (25) Record Head Mounting Gauge M-9048 (DA09048A)
- (26) Back Tension Gauge (DA09055A)
- (27) Tension Arm Adjustment Cassette (DA09056A)
- (28) Audio Analyzer T-100
(including Distortion, Wow/Flutter, Speed, Oscillator and dB meters)

Note: (10) – (28) are the products of Nakamichi Corporation.

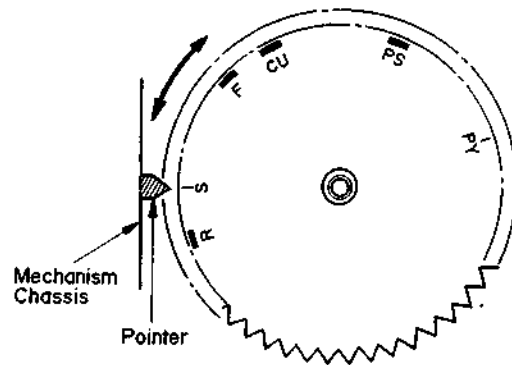

Fig. 4.1

4. MECHANICAL ADJUSTMENTS

4.1. Mechanism Control Cam Adjustment

Before adjustment, disassemble the Front Panel Ass'y, then remove the Cover Plate referring to items 2.4 and 2.17.

(1) Offset Adjustment of Control Motor Driver

(a) Refer to Figs. 4.1 and 4.2.

Adjust VR602 and VR603 on the Logic & Power P.C.B. Ass'y to locate approximately at the middle of the variable range. Then turn ON the Power switch.

VR602 (for Cam position stop)

VR603 (for Cam position play)

(b) Press the Stop button to set the ZX-7 in Stop mode. Adjust VR602 (for stop) so that the "S" mark on the Cam corresponds to the pointer on the mechanism chassis.

(c) Press the Play button to set the ZX-7 in Playback mode.

(Cam will rotate, and the position marked with "PY" comes to the pointer.) Adjust VR603 (for play) so that the "PY" mark on the Cam corresponds to the pointer.

(d) Repeat above (b) and (c) 2 – 3 times so that the "S" and "PY" marks on the Cam correspond to the pointer accurately in Stop and Playback modes respectively.

(This adjustment is required because the position adjusted by one volume will be slightly changed when the other volume is adjusted.)

(e) Set the ZX-7 in F.F., Pause, or Cue mode by pressing each button (press F.F. and Pause buttons to set the ZX-7 in Cue mode) and check to insure that the pointer is in a range of "F", "PS", or "CU" mark respectively.

(f) If out of the range, precise adjustment for each position according to "(2) Offset Fine Adjustment of Control Motor Driver" will be required.

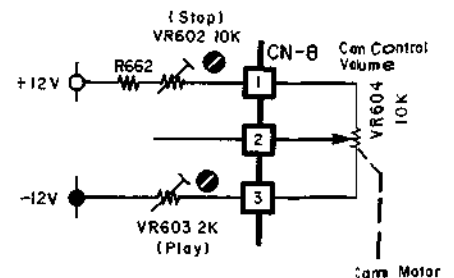

Fig. 4.2

(2) Offset Fine Adjustment of Control Motor Driver

Adjust only if a satisfactory result is not obtained in "(1) Offset Adjustment of Control Motor Driver". This adjustment is made by changing the value of the fixed resistors on the Logic & Power P.C.B. Ass'y.

Note: The value of voltage is typical value.

(a) Observation Point of Reference Voltage

Observe the each voltage at the sliding contact of the Cam Control Volume VR604 (10 kΩ) in Stop, Fast (F.F. or Rew.), Pause and Playback modes.

(b) Reference Voltage

Reference voltage at the sliding contact of VR604 (Cam Control Volume) in each mode is as follows:

Mode	Reference Voltage (Typical Value)
Stop	0 V
Fast (F.F./Rew.)	-2.0 V
Pause	-6.5 V
Play	-9.1 V

} -2.0 V ±0.25 V
} -2.6 V ±0.4 V

(c) Resistors for Adjustment

Mode	Ref. No.	Typical Value
Fast (F.F./Rew.)	R647	22 kΩ
Pause	R649	76.8 kΩ (F)
Play	R648	10 kΩ

(d) Adjustment Procedures

- Set the ZX-7 in Stop mode, then check to insure that the voltage at the sliding contact of VR604 is 0 V (±0.3 V).
- Set the ZX-7 in F.F. mode, then adjust the value of R647 so that the voltage at the sliding contact of VR604 will become lower by 2.0 V (±0.25 V) than in Stop mode.
- Press the Pause button to set the ZX-7 in Pause mode. Adjust the value of R649 to obtain -6.5 V (+0.4, -0.15 V) at the sliding contact of VR604.
- Set the ZX-7 in Playback mode, then adjust the value of R648 so that the voltage at the sliding contact of VR604 will become lower by 2.6 V (±0.4 V) than in Pause mode.

4.2 Reel Motor Speed Adjustment in Play Mode

Refer to Fig. 4.3.

- Connect a DC voltmeter to TP1 and GND on the Logic & Power P.C.B. Ass'y.
- Without loading a cassette tape, set the ZX-7 in Play mode.
- Adjust VR601 on the Logic & Power P.C.B. Ass'y to obtain -4 V on the DC voltmeter.

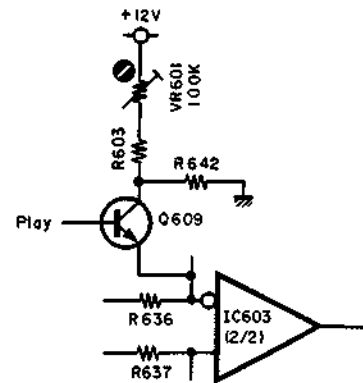

Fig. 4.3

4.3. Record Head and Playback Head Tilt Adjustment

Note: On items 4.3 - 4.9, refer to Fig. 4.4 flow chart. Refer to Figs. 4.5 and 4.6.

- Load a Tilt Check Gauge M-9039 (DA09039A) in the ZX-7.
- Clip the grounding terminal of the Tilt Check Gauge with one end of the cord with clip, and the chassis of the ZX-7 with the other end.
- Remove both of the Height Gears.
- Set the ZX-7 in Play mode. Check to insure whether the Beacons Playback Head "Upper" or "Lower" and Record Head "Upper" or "Lower" are illuminating. In order not to give damages onto the head surfaces, push both of slide knobs of the Gauge to the direction of arrow marks, then return them to the original place to be in contact with record head and playback head surfaces after Play mode is securely locked.
- Check to insure freedom from contact between the Gauge and pad lifter.
- Beacon Playback Head "Lower" will light on when height adjustment screw (P) turned clockwise but Playback Head "Upper" when counterclockwise. Adjust so that both "Upper" and "Lower" will light on even when you move the slide knob to the direction of an arrow mark and then return them to the original place.
- Same procedures will apply to the Beacons Record Head "Upper" and "Lower", except for the height adjustment screw (R).
- Set the ZX-7 in Stop mode and fit both of the serrated Height Gears. Then set the ZX-7 again in Play mode and insure all of the 4 Beacons are illuminating. If not, (3) through (7) will have to be repeated till satisfactory results are obtained.

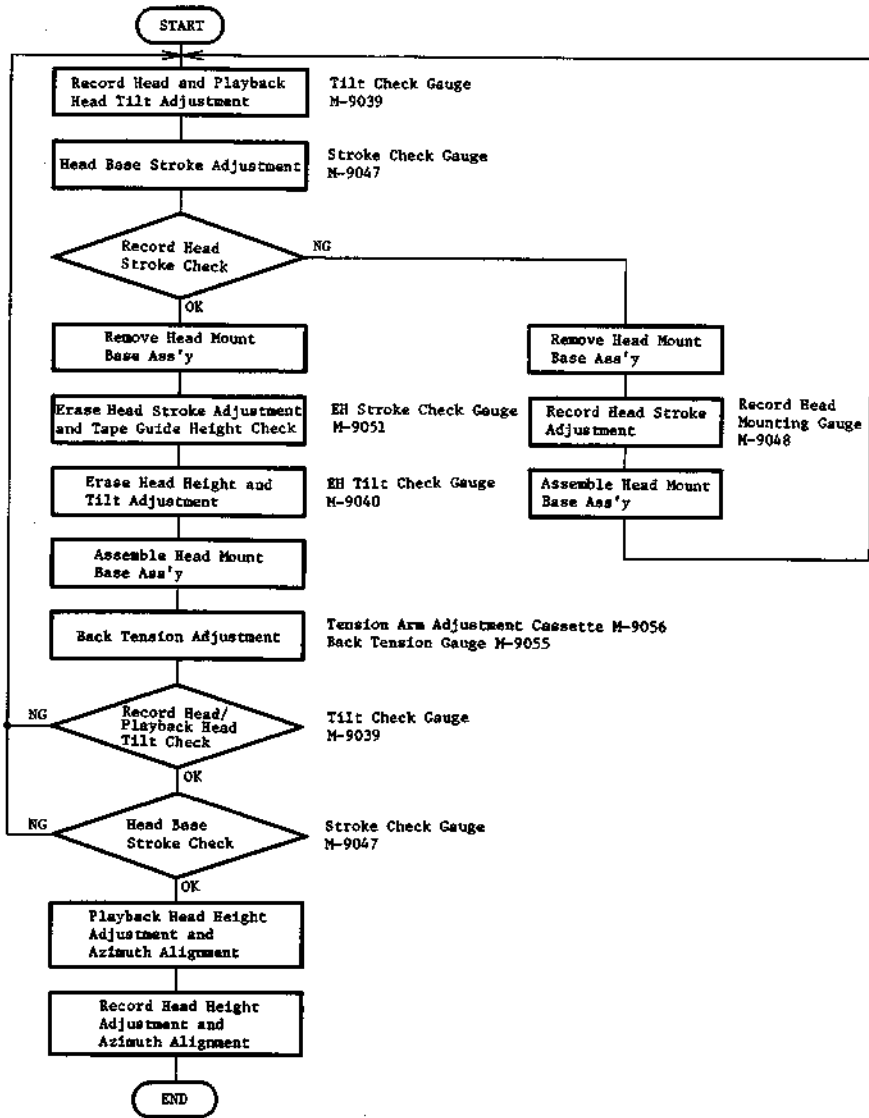

Fig. 4.4

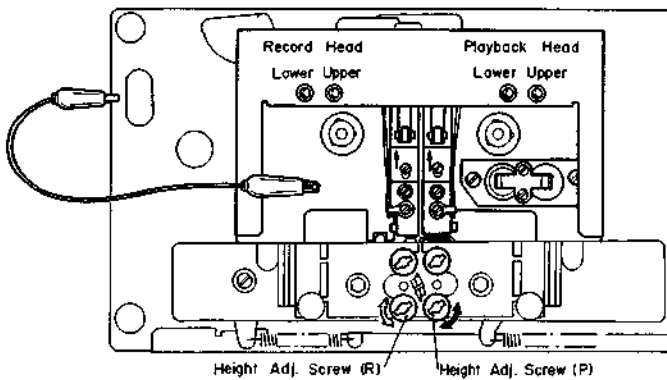

Fig. 4.5

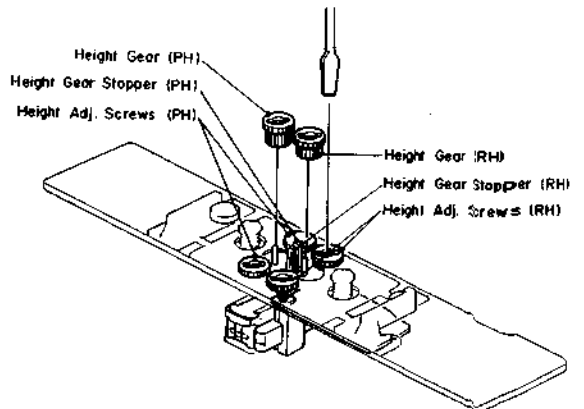

Fig. 4.6

4.4. Head Base Stroke Adjustment

Note: Before you conduct this adjustment, adjust with a "Tilt Check Gauge" to insure freedom from tilt on the playback head and record head.

(1) Head Base Stroke Adjustment in Play Mode

Refer to Fig. 4.7.

- (a) Load a Stroke Check Gauge M-9047 (DA09047B) in the ZX-7.
- (b) Move Record Head Indicator and Playback Head Indicator to the direction of arrow mark "A" with your finger tip and then set the ZX-7 in Play mode. Then slowly release the Indicators and insure whether each of the Indicators is in contact with record and playback heads.
- (c) Check to insure whether the "P" pointer on the Playback Head Indicator locates between the 2 lines on the Indicator Plate.
- (d) If the playback head stroke is noted to be misaligned, adjustment can be made by moving the stroke adjuster assembled in the head base assembly (either forwardly or backwardly).
- (e) Check to insure whether the "P" pointer on the Playback Head Indicator locates between the 2 lines on the Record Head Indicator, thus check can be made on record head stroke.
- (f) If the record head stroke is noted to be misaligned, adjustment can be made with a Record Head Mounting Gauge M-9048 (DA09048A).

(2) Head Base Stroke Adjustment in Cue Mode

Refer to Figs. 4.7 and 4.8.

- (a) Load a Stroke Check Gauge M-9047 (DA09047B) in the ZX-7.
- (b) Move Record Head Indicator and Playback Head Indicator to the direction of arrow mark "A" with your finger tip and then set the ZX-7 in Cue (F.F. and Pause) mode. Then slowly release the Indicators and insure whether each of the Indicators is in contact with record and playback heads.
- (c) Check to insure whether the "C" pointer on the Playback Head Indicator locates between the 2 lines on the Indicator Plate.
- (d) If the playback head stroke is noted to be misaligned, adjust VR610 on the Logic & Power P.C.B. Ass'y till satisfactory results are obtained.
- (e) After completion of the Head Base Stroke Adjustment, check to insure accuracy of the Head Base Stroke Adjustment in Play mode. If the above are inaccurate, items (1) and (2) will have to be repeated till satisfactory results are obtained.

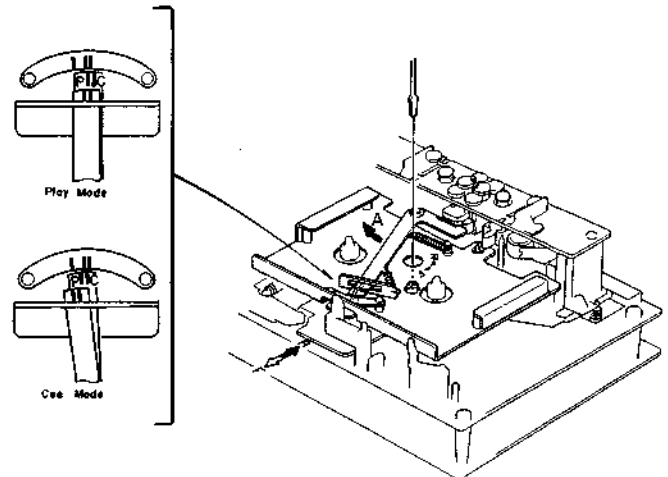

Fig. 4.7

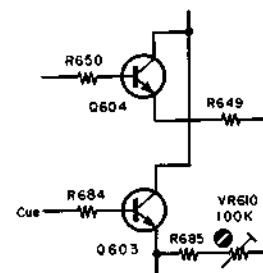

Fig. 4.8

4.5. Erase Head Stroke Adjustment and Tape Guide Height Check

Remove Head Mount Base Ass'y referring to item 2.24. Refer to Figs. 4.9 and 4.10.

(1) Erase Head Stroke Adjustment

- (a) Load an EH Stroke Check Gauge M-9051 (DA09051A) in the ZX-7.
- (b) Set the ZX-7 in Play mode, thus check can be made on erase head stroke through the EH Stroke Indicator.
- (c) Check to insure whether the erase head surface is aligned with red line on the EH Stroke Indicator. If not, adjust the erase head stroke by loosening 2 screws A that assemble erase head and erase head plate.
- (d) After completion of adjustment, 2 pcs. of screws shall be locked with lock tight paint.

(2) Supply Tape Guide Height Check

- (a) Load an EH Stroke Check Gauge M-9051 (DA09051A) in the ZX-7.
- (b) Set the ZX-7 in Play mode.
- (c) Slide the Supply Tape Guide Check Bar down against the supply tape guide, and check to insure that the Supply Tape Guide Check Bar is accepted by the supply tape guide.

(3) Take-up Tape Guide Height Check

- (a) Load an EH Stroke Check Gauge M-9051 (DA0-9051A) in the ZX-7.
- (b) Set the ZX-7 in Play mode.
- (c) Slide the Take-up Tape Guide Check Bar down against the take-up tape guide, and check to insure that the Take-up Tape Guide Check Bar is accepted by the take-up tape guide.

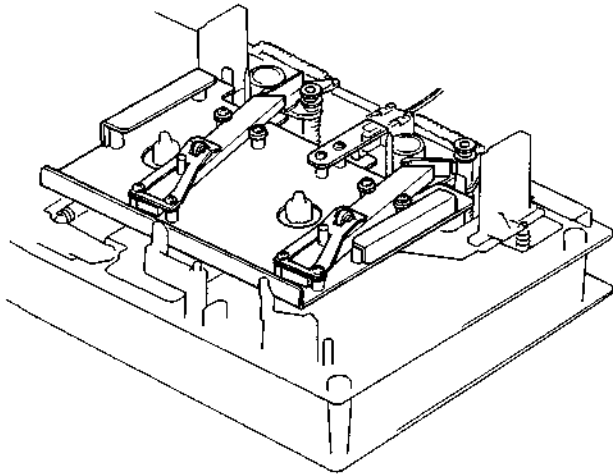

Fig. 4.9

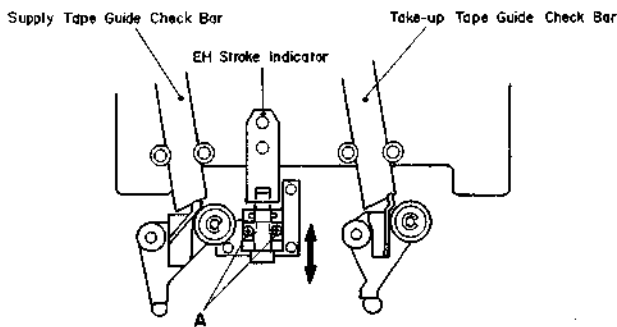

Fig. 4.10

4.6. Erase Head Height and Tilt Adjustment

Refer to Figs. 4.11 and 4.12.

- (1) Remove Head Mount Base Ass'y referring to item 2.23.
- (2) Load an EH Tilt Check Gauge M-9040 (DA09040A) in the ZX-7.
- (3) Set the ZX-7 in Stop mode.
- (4) Check to insure whether one of the 3 Beacons is illuminating. Look down the mirror as shown by an arrow mark and slowly turn the Screw "Height" counterclockwise (or clockwise) so that the two horizontal lines on the mirror will become superposed on the line (in different color) of the erase head, and check to insure whether Beacon "1" is illuminating.
- (5) Turn Screw "Tilt" counterclockwise (or clockwise) to light on Beacon "2". Excessive turning will cause

the Beacon "1" to light off. Adjustments of Screw "Tilt" will therefore be conducted till both of the Beacons "1" and "2" illuminate.

- (6) Turn Screw "Azimuth" counterclockwise (or clockwise) to light on Beacon "3". Excessive turning will cause either Beacon "1" or "2" to light off, and therefore adjust Screw "Azimuth" until all of the 3 Beacons "1", "2" and "3" illuminate.
- (7) Check to insure whether the horizontal line on the mirror corresponds to that on the erase head. If not, (4) through (7) will have to be repeated till satisfactory results are obtained.
- (8) After completion of adjustment, 3 pcs. of screws shall be locked with lock tight paint.

Note: Before use of this gauge, check to insure freedom from dust or dirt, or overflow in the groove of the erase head surface.

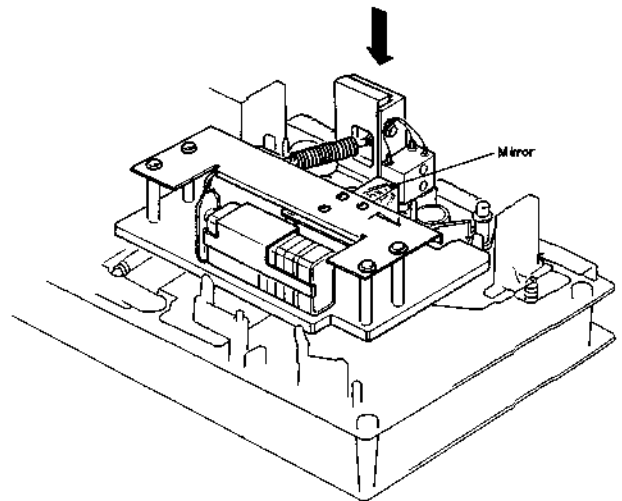

Fig. 4.11

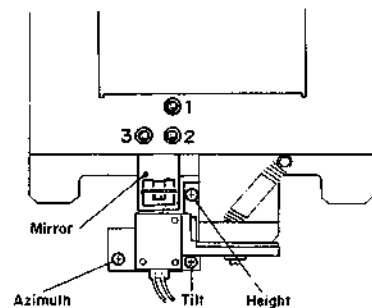

Fig. 4.12

4.7. Back Tension Adjustment

Refer to Figs. 4.13 – 4.16.

- (1) Load a Tension Arm Adjustment Cassette (DA09056A) in the ZX-7 referring to Fig. 4.13.
- (2) Set the ZX-7 in Play mode.
- (3) Bend the Back Tension Arm with pliers so that the gap between the Cassette Holding Spring assembled on the Head Base Ass'y and the Back Tension Arm becomes 0.5 mm as shown in Fig. 4.14. Do not bend the top of the Back Tension Arm.
- (4) Set the ZX-7 in Stop mode, and remove the Tension Arm Adjustment Cassette (DA09056A), then set the ZX-7 in Cue mode.

In Cue mode, check to insure that the gap is found between the Supply Reel Hub B Ass'y and the Felt of Back Tension Ass'y as shown in Fig. 4.15.

- (5) Load the Back Tension Gauge (DA09055A) in the ZX-7.
- (6) Set the ZX-7 in Play mode and read the torque value of Back Tension Gauge.

If the value is in a range of 6 g-cm to 10 g-cm, adjustment is not necessary. If not, change the installation point of the Back Tension Spring as shown in Fig. 4.16, and obtain the torque of 7 g-cm to 9 g-cm range.

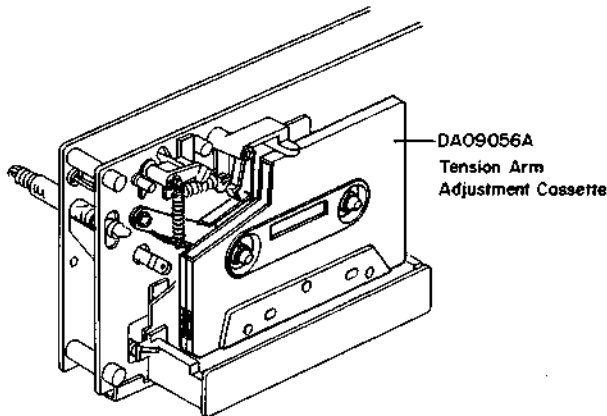

Fig. 4.13

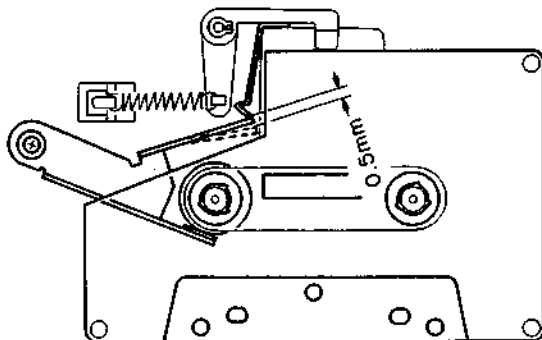

Fig. 4.14

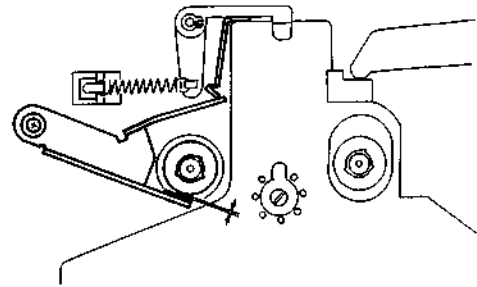

Fig. 4.15

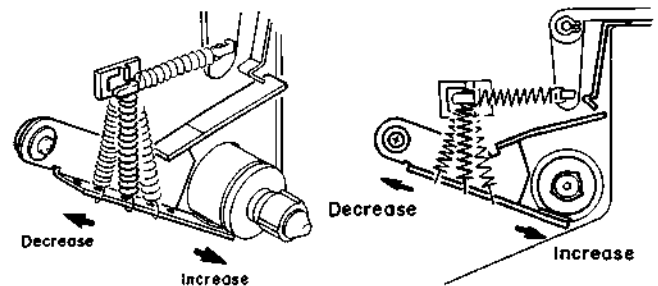

Fig. 4.16

4.8. Playback Head and Record Head Height Adjustment and Azimuth Alignment

(1) Playback Head Height Adjustment and Azimuth Alignment

Refer to Fig. 4.17.

- (a) Set the Monitor switch to Tape, then connect a VTVM to the Output Jacks.
- (b) Load a 1 kHz Track Alignment Tape (DA09007A), then set the ZX-7 in Play mode.
- (c) Turn the PH Height Gear until the outputs of both channels become minimum.
- (d) Load a 15 kHz Azimuth Tape (DA09004A), then set the ZX-7 in Play mode.
- (e) Turn the PH Azimuth Alignment Screw until the outputs of both channels become maximum.
- (f) Repeat above steps (b) through (e) one or two times to obtain optimum performance.

(2) Record Head Height Adjustment and Azimuth Alignment

Refer to Figs. 4.17 – 4.20.

- (a) Set the ZX-7 in Stop mode.
- (b) Press the Azimuth Alignment Start button to ON.
- (c) Adjust the Azimuth Alignment Knob so that the Slide Lever of the Azimuth Alignment Wire is located at the center of the slit of the Azimuth Alignment Wire as shown in Fig. 4.18.
- (d) Press the Azimuth Alignment Start button to OFF.
- (e) Set the Monitor switch to Tape, Eq. switch to 70μs and Tape Selector button to SX.
- (f) Load a reference SX tape (DA09025A) and connect a VTVM to Output Jacks.

- (g) Press the Record and Play buttons, then press the Level Calibration Start button to oscillate 400 Hz. Turn the RH Height Gear until the outputs of both channels become maximum.
 - (h) Press the Bias Calibration Start button to oscillate 15 kHz, then turn the RH Azimuth Alignment Screw until the outputs of both channels become maximum.
 - (i) Repeat (g) and (h) one or two times to obtain optimum performance.
 - (j) Press the Record and Play buttons, then press the Azimuth Alignment Start button to ON. Adjust VR304 on the Main P.C.B. Ass'y so that the red indicator in the middle of the Azimuth Indicator is lit up.
- Note: Use the same side of the tape as used in the above steps.
- (k) After completion of the above adjustment, press the

Record and Play buttons, then press the Level Calibration Start button to oscillate 400 Hz. Record 400 Hz tone to the same portion of both sides A and B of the tape.

- (l) Immerse the recorded tape in a magnetized developing solution. In turn, check to insure that the recording head tracks across the center are separated with a distance of 0.55 to 0.75 mm (typically 0.65 mm) as illustrated in Fig. 4.20.

Note: Liquid for tape magnetized development solution "MAGNA-SEE SOUND CRAFT a product of CBS RECORDS a division of Columbia Broadcasting System, Inc., Danbury, Conn. 06810 U.S.A., or equivalent". After development, clean the tape otherwise pressure rollers and heads will become dirty.

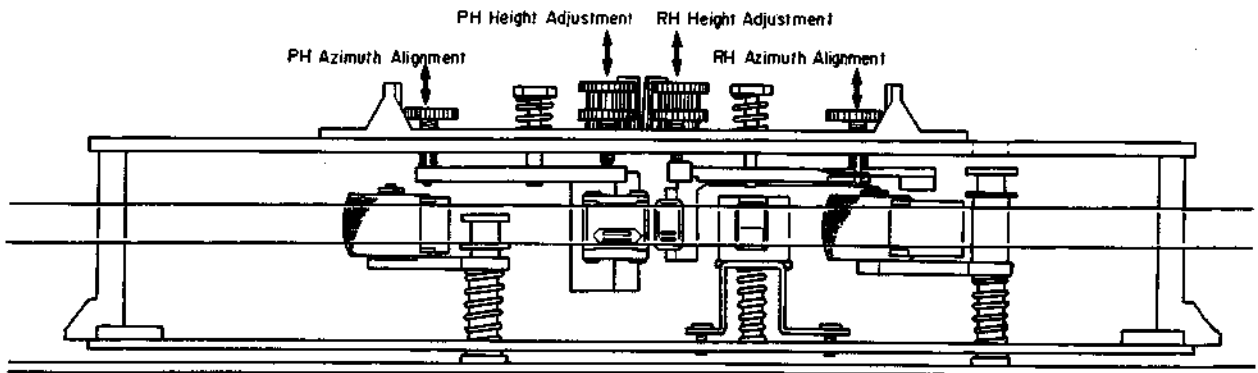

Fig. 4.17

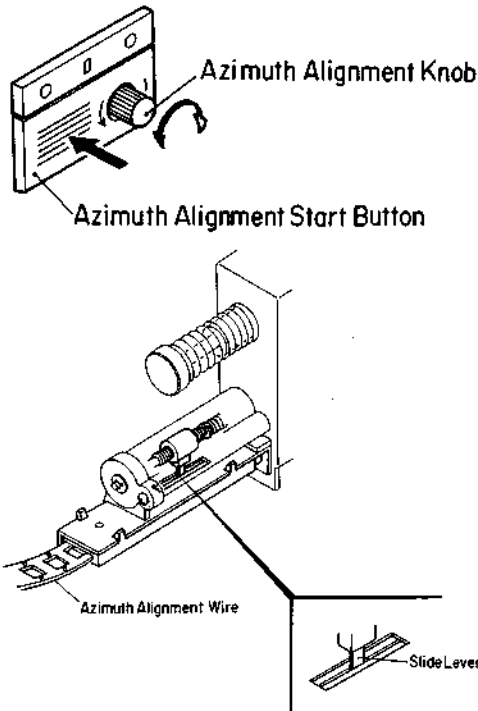

Fig. 4.18

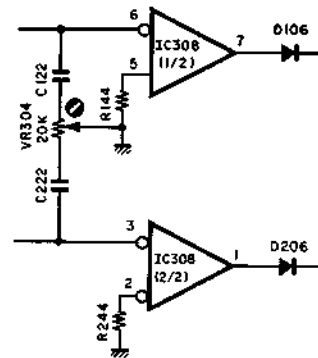

Fig. 4.19

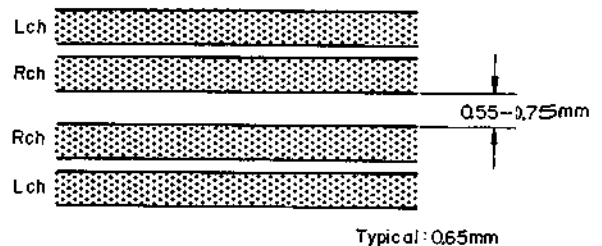

Fig. 4.20

4.9. Record Head Stroke Adjustment

Refer to Figs. 4.21 and 4.22.

Note: This adjustment will be required only to insure freedom from misalignment of the record head stroke in the record head stroke check mode.

- (1) Check the accuracy of the record head stroke.
- (2) Remove Head Mount Base Ass'y referring to item 2.23.
- (3) Remove the record head assembly.
- (4) Adjustment of Record Head Mounting Gauge M-9048 (DA09048A)
 - (a) Mount the Block B onto the Mounting Gauge Plate.
 - (b) Loosen the 2 screws fixing the Block A.
 - (c) As shown in Fig. 4.21, hold the Gauges (3.05 mm and 0.1 mm thickness) between the Block A and Block B, and fix the Block A with screws, pushing the Block A to the 2 guide pins.
- (5) Remove the Block B from the Mounting Gauge Plate.
- (6) As shown in Fig. 4.22, mount the R-8L record head assembly onto the Mounting Gauge Plate, then check the location of the R-8L record head surface. (If record head contacts to the Block C, loosen 2 pcs. of screws that assemble record head and record head plate, then place the R-8L record head assembly onto the Plate.)
- (7) Remove the R-8L record head assembly from the Mounting Gauge Plate.
- (8) Readjustment of Record Head Mounting Gauge M-9048 (DA09048A)
 - (a) Mount the Block B onto the Mounting Gauge Plate.

- (b) Loosen the 2 screws fixing the Block A.
- (c) As shown in Fig. 4.21, hold the Gauges (3.05 mm and either one of 0.05, 0.15, 0.2, 0.25, 0.3 or 0.35 mm thickness) between the Block A and Block B, and fix the Block A with screws, pushing the Block A to the 2 guide pins.
- (9) Remove the Block B from the Mounting Gauge Plate.
- (10) Mount the R-8L record head assembly onto the Mounting Gauge Plate.
- (11) As shown in Fig. 4.22, loosen 2 pcs. of screws that assemble record head and record head plate. As the location of the Block A is secured by the item (8)-(c), push the record head to the directions A and B, then tighten 2 pcs. of screws.
- (12) Check to insure freedom from gap between the Block C and record head surface, then tighten the 2 pcs. of screws on the record head assembly with lock tight paint.
- (13) Remove the R-8L record head assembly from the Mounting Gauge Plate.
- (14) Assemble the record head assembly to the head mount base assembly.
- (15) Assemble the head mount base assembly to the mechanism assembly.
- (16) Check the record head stroke. If the above are inaccurate, items (1) through (16) will have to be repeated till satisfactory results are obtained.

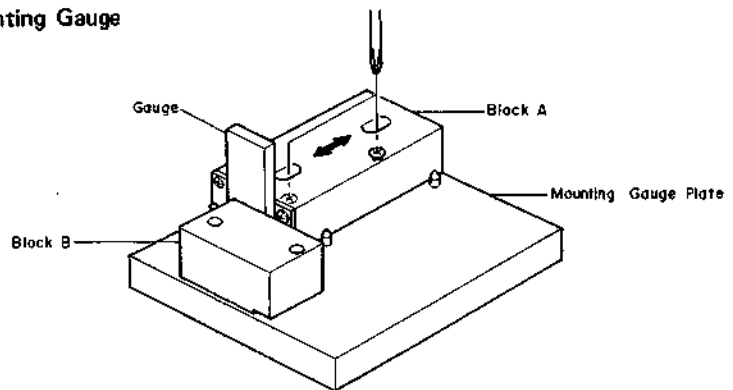
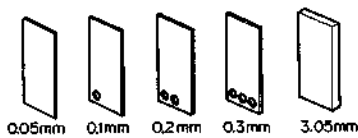

Fig. 4.21

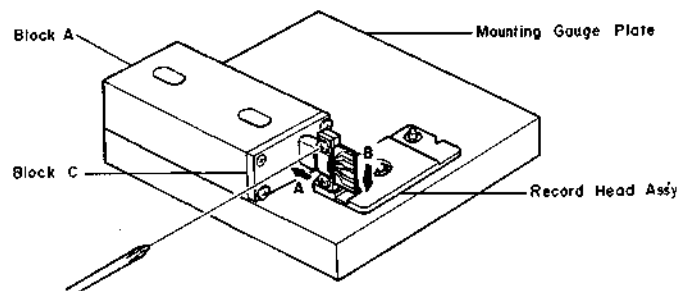

Fig. 4.22

4.10. Tape Travelling Adjustment

The adjustment shall be made with a modified version of the current type EXII C-90 as shown in Fig. 4.23 (error will be made if a current type Tape Travelling Cassette (DA09011A) should be used for this purpose).

While modifying an EXII C-90, the tape guides in the cassette housing shall be kept protected to avoid tilt. Check shall be made in the following procedures:

- (1) An EXII C-90 tape thus modified shall be loaded onto the ZX-7.
- (2) Release the back-tension (rotate the Supply Reel and feed out some length of tape) and set the ZX-7 in Play mode.
- (3) In this juncture, check to insure whether the tape is free from waving or slippage from the tape guide.
- (4) When the modified EXII C-90 is played back, check to insure whether the tape is freedom from waving from head surface or at pressure rollers.
- (5) If either of waving or slippage from the tape guide should be noted, adjustments of "4.3. Record Head and Playback Head Tilt Adjustment", "4.4. Head Base Stroke Adjustment", "4.5. Erase Head Stroke Adjustment and Tape Guide Height Check", "4.6. Erase Head Height and Tilt Adjustment", "4.7. Back Tension Adjustment", "4.8. Playback Head and Record Head Height Adjustment and Azimuth Alignment", "4.9. Record Head Stroke Adjustment", etc. will be required.

As a case may be, the said waving or slippage may have been caused from defective supply Pressure Roller Ass'y or Take-up Pressure Roller Ass'y without parallel contact with capstans. If such are noted, the Pressure Roller Assemblies will have to be replaced.

Further, excessively weak take-up torque or strong take-up torque may cause defective tape travelling.

The ZX-7 is intended to be an adjustment-free model, however if the similar matters as above should be noted, please replace the Reel Hub Ass'y to obtain appropriate take-up torque.

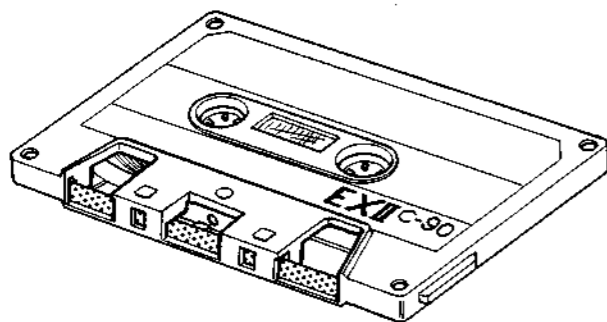

Fig. 4.23

4.11. Flywheel Holder Adjustment

- (1) Refer to Fig. 4.24.

Tighten the Thrust Screws until the gap between the Flywheel Assemblies and Thrust Screws becomes minimized when both of the Capstan Shafts are moved backwardly and forwardly (the Thrust Springs between the Capstan Flanges and Flywheel Thrust Caps are in a flat state).

Excessive tightening of the Thrust Screws however will give damages on the Flywheel Assemblies, to which careful attention is invited.

- (2) Return the Thrust Screws by 1/2 turn.
- (3) Fixing the Thrust Screws with a screwdriver, lock the Lock Nut.
- (4) Apply a quantity of lock tight paint to the Thrust Screws.

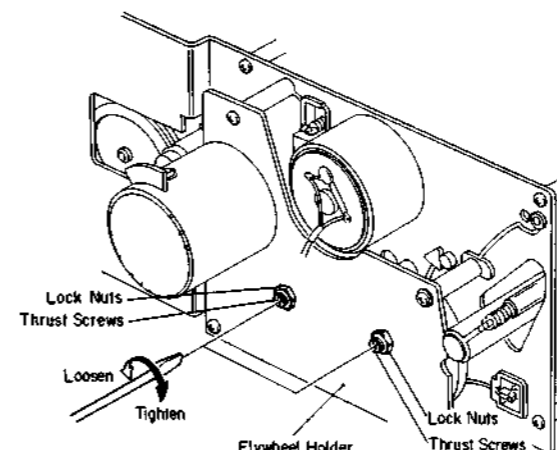

Fig. 4.24

4.12. Tape Speed Adjustment

Refer to Fig. 4.25.

- (1) Remove the Top Cover Ass'y referring to item 2.1.
- (2) Connect a Frequency Counter to the Output Jack.
- (3) Load a 3 kHz Speed Wow/Flutter Tape (DA09006A) and play it back.
- (4) Adjust the Tape Speed Adjustment Volume (VR501) incorporated in the Capstan Motor to obtain 3,000 Hz on the Frequency counter.

CCW: Motor drives slowly.

CW: Motor drives fast.

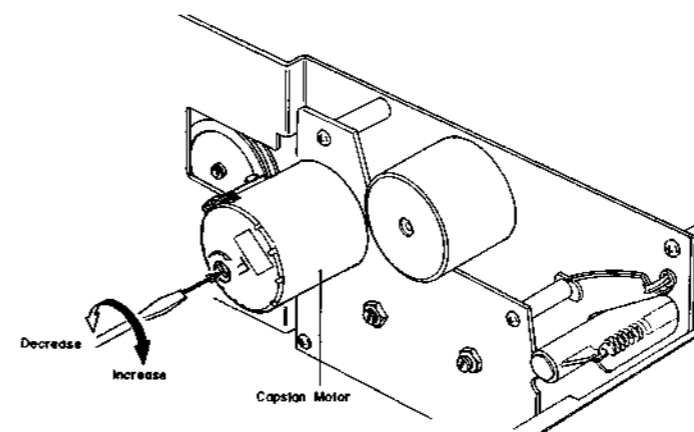

Fig. 4.25

4.13. Lubrication

ZX-7 is a lubrication-free cassette deck except when parts are replaced. Apply the following lubricant for each replaced part:

- (1) LAUNA #100
Capstan Shaft
Pressure Roller Shaft
Thrust Cap
- (2) FLOIL GB-TS-1
Reel Hub Shaft
Thrust portion on the Capstan Shaft
FLOIL GB-TS-1, made by Kanto Chemicals Co., Ltd. in Japan.
We suggest that you use the above or equivalent type. If unavailable please contact Kanto Chemicals Co., Ltd., 2-7 Kanda Suda-cho Chiyoda-ku, Tokyo 101 Japan.

- (3) Silicon Oil #3000 CST
Air Damper Piston
- Note: Excessive lubrication may cause defective damper action as the 0.2^φ hole at the end of the cylinder may be filled with oil.

5. PARTS LOCATION FOR ELECTRICAL ADJUSTMENT

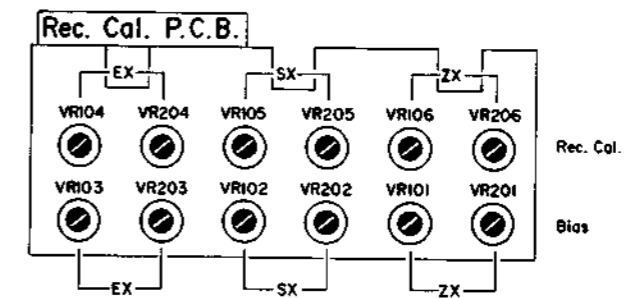
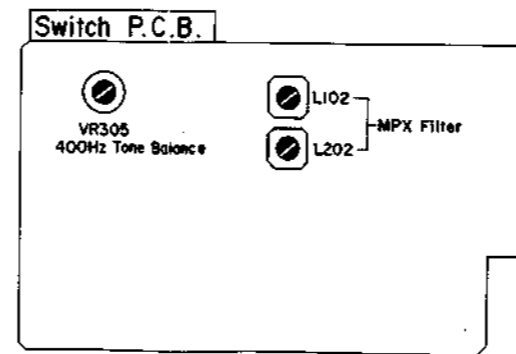
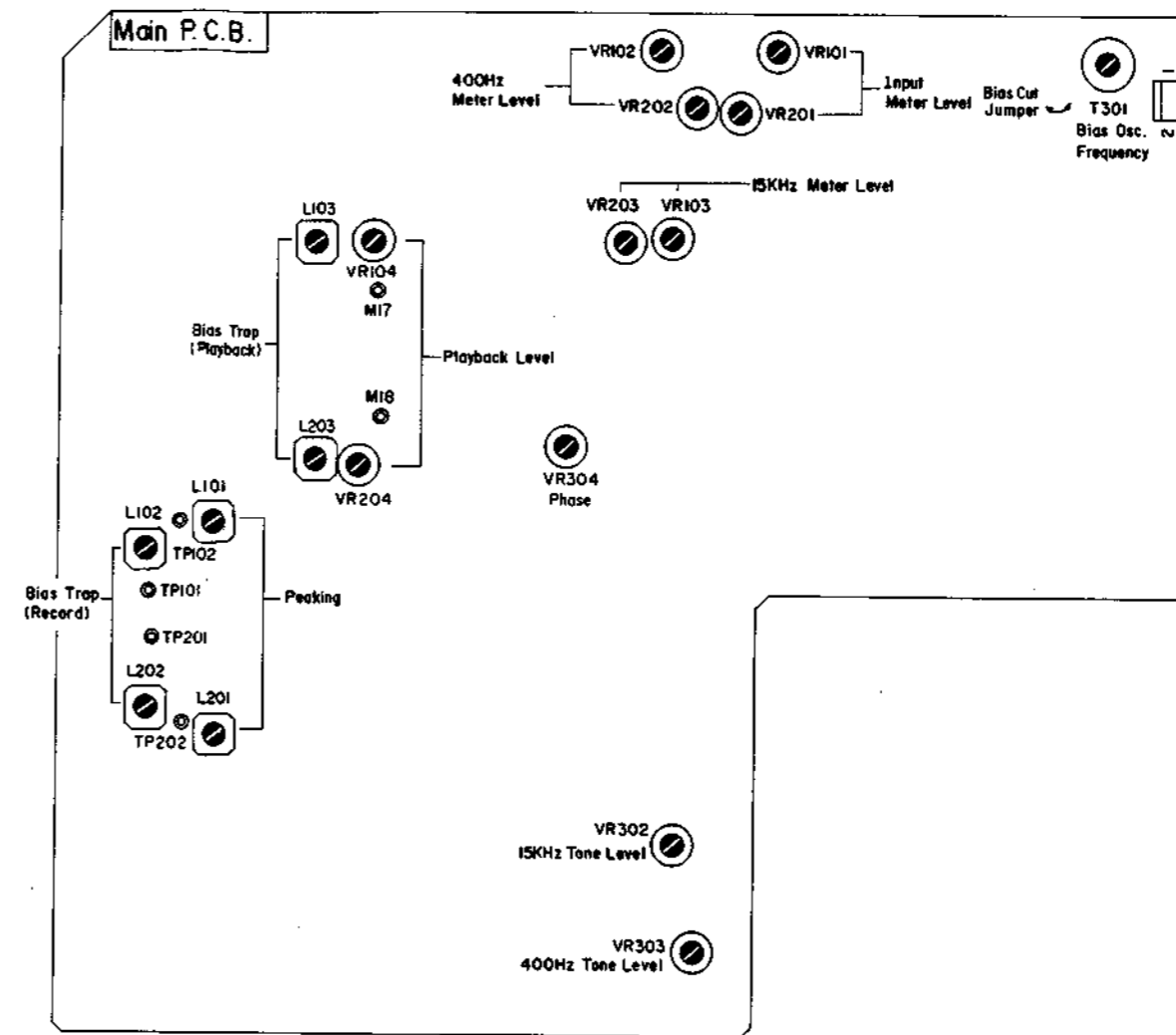
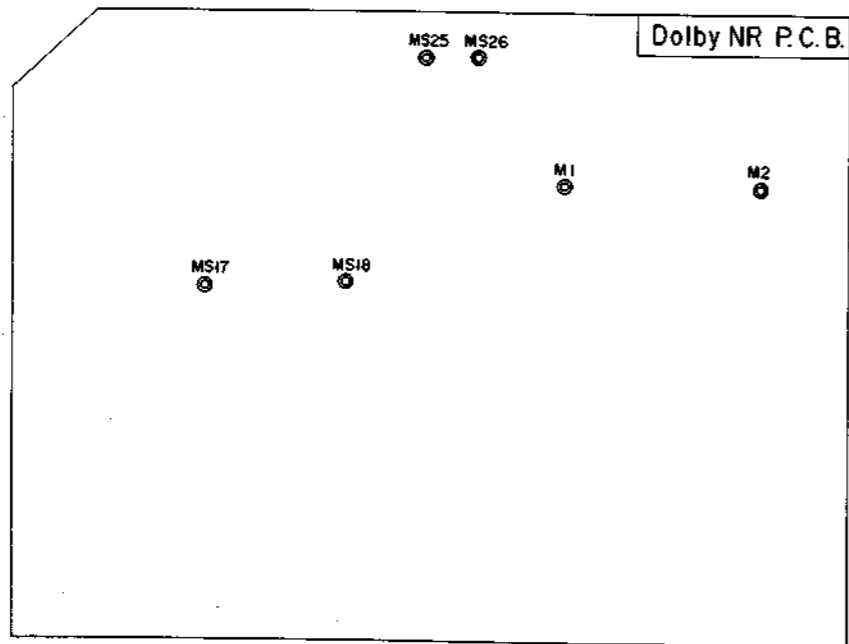
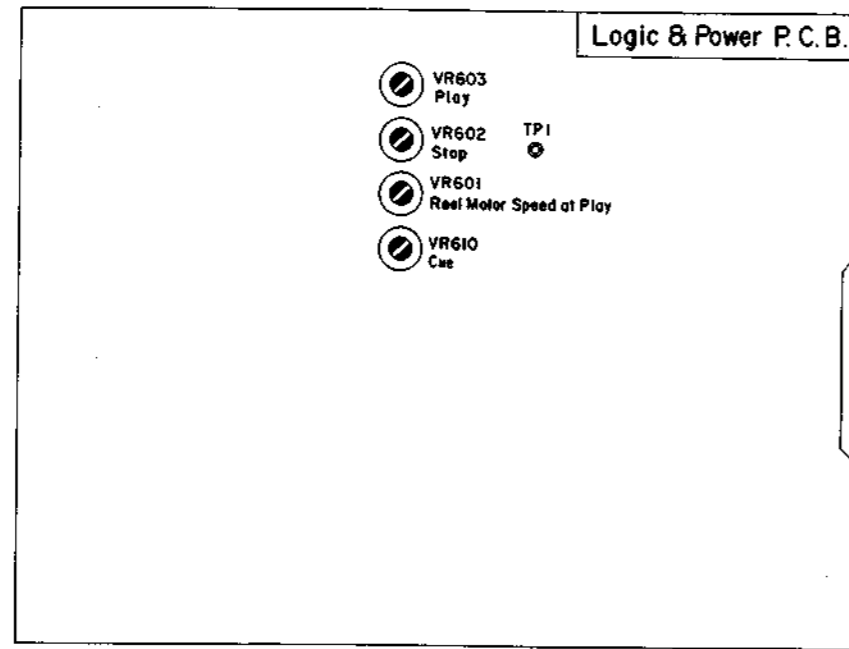

Fig. 5

6. ELECTRICAL ADJUSTMENTS AND MEASUREMENTS

6.1. Adjustment and Measurement Instructions

Note: Electrical adjustment should be performed after mechanical adjustment is completed.

STEP	ITEM	SIGNAL SOURCE	OUTPUT CONNECTION	MODE	ADJUSTMENT	REMARKS
1	Tape Speed Adjustment	3 kHz Speed and Wow/Flutter Tape (DA09006A)	Frequency Counter to Output Jacks	Playback	Capstan Motor Governor P.C.B. VR501	Adjust VR501 to obtain 3 kHz $\pm 0.5\%$. (VR501 is incorporated in the Capstan Motor.)
2	Tone Level Calibration	Tone 400 Hz and 15 kHz	VTVM to MS25, MS26 on Dolby NR P.C.B. and Output Jacks	Tone - 400 Hz/15 kHz Monitor SW - Source	Main P.C.B. VR303 (for 400 Hz) VR302 (for 15 kHz) Switch P.C.B. VR305 (400 Hz Balance)	<ol style="list-style-type: none"> 1. Press the Level Calibration Start button to oscillate 400 Hz. 2. Adjust VR303 to obtain 90 mV on the VTVM at MS26 (R ch). 3. Adjust VR305 to obtain the same level as R ch on the VTVM at MS25. 4. Measure the reading on the VTVM at the Output Jacks. 5. Press the Bias Calibration Start button to oscillate 15 kHz. 6. Adjust VR302 to obtain 20 dB lower level than in 4 on the VTVM at the Output Jacks. 7. Press the Calibration Reset button to stop the tone oscillation.
3	Meter Level Calibration	400 Hz to Input Jacks and Tone 400 Hz and 15 kHz	VTVM to MS25, MS26 on Dolby NR P.C.B.	Tone - OFF/400 Hz/15 kHz Monitor SW - Source	Main P.C.B. VR101, VR201 VR102, VR202 VR103, VR203 VR303 (for 400 Hz) VR302 (for 15 kHz)	<ol style="list-style-type: none"> 1. Feed in 400 Hz, then adjust the Input Level controls to obtain 90 mV -1.3 dB on the VTVM. 2. Adjust VR101 (VR201) so that the 0 dB segment of the level meter starts illuminating. 3. Press the Level Calibration Start button to oscillate 400 Hz, then adjust VR303 to obtain 90 mV -0.5 dB on the VTVM. 4. Adjust VR102 (VR202) so that the 0 dB segment of the level meter starts illuminating. 5. Press the Bias Calibration Start button to oscillate 15 kHz, then adjust VR302 to obtain 9 mV -0.5 dB on the VTVM. 6. Adjust VR103 (VR203) so that the 0 dB segment of the level meter starts illuminating. 7. Press the Calibration Reset button. 8. Re-adjust the tone level according to step 2 "Tone Level Calibration".
4	MPX Filter Adjustment	19 kHz ± 100 Hz to Input Jacks	VTVM to Output Jacks	Monitor SW - Source Dolby NR SW - OFF MPX Filter SW - IN	Switch P.C.B. L102, L202	<ol style="list-style-type: none"> 1. Turn the Output level control fully clockwise (maximum position). 2. Adjust the Input Level controls to obtain 1 V on the VTVM. 3. Set the MPX Filter switch to IN, then adjust L102 (L202) to obtain the minimum reading on the VTVM (the minimum reading will be less than -30 dB).
5	Playback Head Track Alignment	1 kHz Track Alignment Tape (DA09007A)	VTVM to Output Jacks	Playback Monitor SW - Tape Eq. SW - $70 \mu s$ Dolby NR SW - OFF MPX Filter SW - OUT	PH Height Gear	Adjust the PH Height Gear to obtain minimum readings of both channels on the VTVM. Refer to "Playback Head Height Adjustment and Azimuth Alignment" in item 4.8.

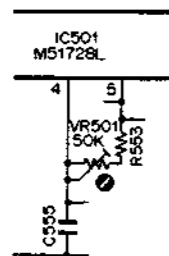

Fig. 6.1
1. Tape Speed

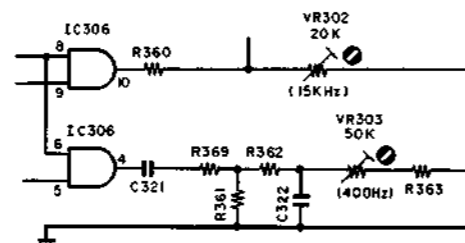

Fig. 6.2
2. Tone Level
3. Meter Level

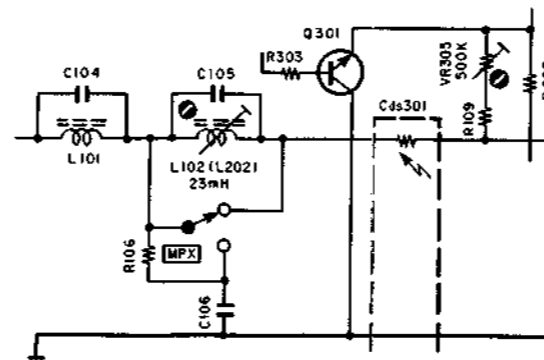

Fig. 6.3
2. Tone Level
4. MPX Filter

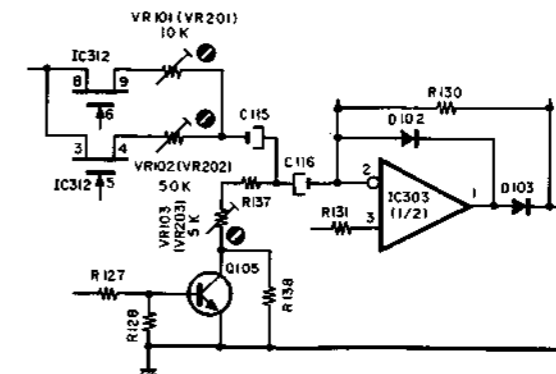

Fig. 6.4
3. Meter Level

STEP	ITEM	SIGNAL SOURCE	OUTPUT CONNECTION	MODE	ADJUSTMENT	REMARKS
6	Playback Head Azimuth Alignment	15 kHz Azimuth Tape (DA09004A)	VTVM to Output Jacks	Playback Monitor SW - Tape Eq. SW - 70 μ s Dolby NR SW - OFF MPX Filter SW - OUT	Playback Head Azimuth Alignment Screw	Adjust the Playback Head Azimuth Alignment Screw to obtain maximum readings of both channels on the VTVM. Refer to "Playback Head Height Adjustment and Azimuth Alignment" in item 4.8. Note: Repeat steps 5 and 6 one or two times to obtain optimum performance.
7	Playback Level Calibration	400 Hz Level Tape (DA09005A)	VTVM to MS25, MS26 on Dolby NR P.C.B.	Same as above	Main P.C.B. VR104, VR204	Adjust VR104 (VR204) to obtain 90 mV on the VTVM.
8	Playback Frequency Response Adjustment	400 Hz Level Tape (DA09005A) 10 kHz PB Frequency Response Tape (DA09003A) 15 kHz PB Frequency Response Tape (DA09002A) 20 kHz PB Frequency Response Tape (DA09001A)	VTVM to Output Jacks	Playback Monitor SW - Tape Tape SW - SX Eq. SW - 70 μ s Dolby NR SW - OFF MPX Filter SW - OUT	Main P.C.B. R155, R255 R156, R256	1. Load a 400 Hz level tape and play it back. Adjust the Output level control to a certain level (0 dB for example). 2. Load 10 kHz, 15 kHz and 20 kHz PB frequency response tapes and adjust the playback head azimuth to obtain maximum levels on the VTVM with each tape. Short R155 (R255) or R156 (R256) to obtain the following levels against the level for the 400 Hz level tape. 10 kHz: -20 dB -1 dB to +2 dB 15 kHz: -20 dB -1 dB to +3 dB 20 kHz: -20 dB -1 dB to +4 dB 3. Conduct step 6 "Playback Head Azimuth Alignment". 4. If above is not sufficient, refer to "Playback Frequency Response Adjustment" in item 6.2.
9	Bias Oscillation Frequency and Erase Current Adjustment		VTVM across the additional 0.1 Ω resistor and Frequency Counter to CN-1-1 on Main P.C.B.	Record, Pause Monitor SW - Source Tape SW - ZX Eq. SW - 70 μ s Dolby NR SW - OFF MPX Filter SW - OUT	Main P.C.B. T301 R309, R310	1. Connect an additional 0.1 Ω resistor in series to the Erase Head, then connect a VTVM across it. 2. Adjust T301 to obtain 105 kHz on the frequency counter. 3. Check the erase current by the VTVM. Erase current will be in a range of 310 mA to 400 mA (typically approx. 350 mA). If erase current is not sufficient, increase it by shorting R309 or R310. 4. After completion of the erase current adjustment, re-check the bias oscillation frequency. 5. Remove the additional 0.1 Ω resistor.
10	Record Amplifier Equalizer Adjustment	23 kHz (-20 dB) to Input Jacks	VTVM to TP101, TP201 on Main P.C.B.	Same as above	Main P.C.B. L101, L201	1. Remove the bias-cut-jumper from the dip side of the Main P.C.B. Ass'y. 2. Adjust L101 (L201) to obtain peak reading at 23 kHz on the VTVM. 3. Re-solder the bias-cut-jumper.
11	Bias Trap Adjustment (Record Amp.)	Remove input signals	VTVM to TP102, TP202 on Main P.C.B.	Same as above	Main P.C.B. L102, L202	Adjust L102 (L202) to obtain minimum reading on the VTVM.

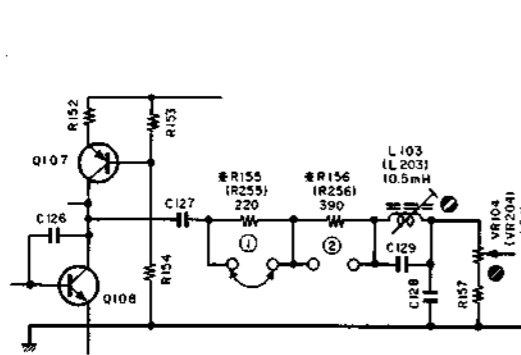

Fig. 6.5

- 7. Playback Level
- 8. Playback Frequency Response
- 12. Bias Trap (Playback Amp.)

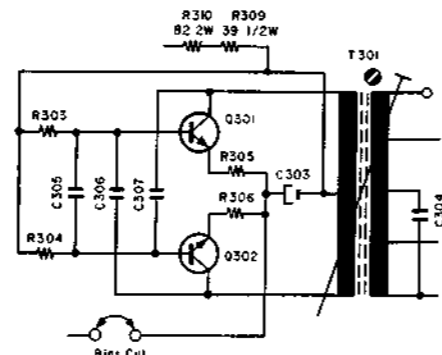

Fig. 6.6

- 9. Bias Oscillation Frequency and Erase Current

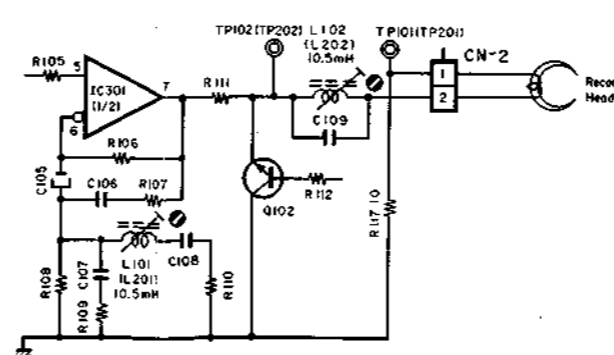

Fig. 6.7

- 10. Record Amp. Equalizer
- 11. Bias Trap (Record Amp.)

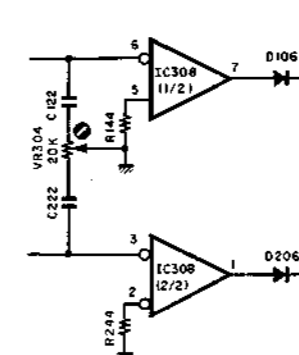

Fig. 6.8

- 13. Record Head Height and Azimuth

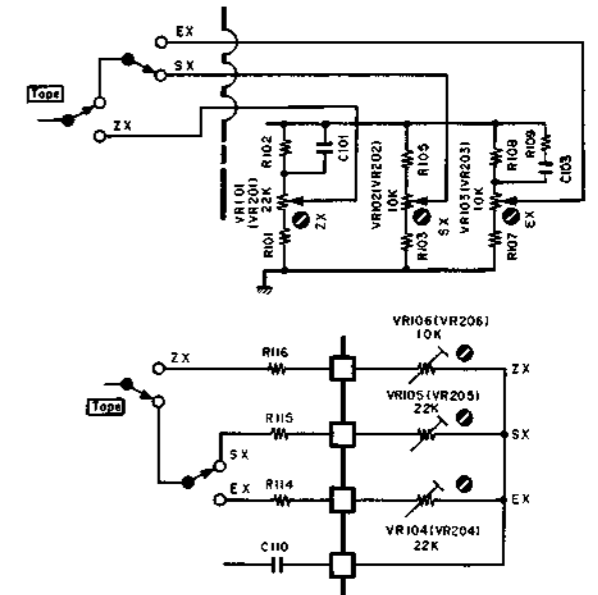

Fig. 6.9

- 13. Record Head Height and Azimuth
- 14. Record Level and Recording Bias Current

STEP	ITEM	SIGNAL SOURCE	OUTPUT CONNECTION	MODE	ADJUSTMENT	REMARKS
12	Bias Trap Adjustment (Playback Amp.)	Remove input signals	VTVM to M17, M18 on Main P.C.B.	Record, Pause Monitor SW - Tape Tape SW - ZX Eq. SW - 70 μ s Dolby NR SW - OFF	Main P.C.B. L103, L203	Adjust L103 (L203) to obtain minimum reading on the VTVM.
13	Record Head Height Adjustment and Azimuth Alignment	Tone 400 Hz and 15 kHz	VTVM to Output Jacks	Record, Playback Monitor SW - Tape Tape SW - SX Eq. SW - 70 μ s Dolby NR SW - OFF	RH Height Gear Record Head Azimuth Alignment Screw Rec. Cal. P.C.B. (Level) VR105, VR205 (Bias Current) VR102, VR202 Main P.C.B. VR304 (Phase)	<ol style="list-style-type: none"> In Stop mode, press the Azimuth Alignment Start button to ON. Then adjust the Azimuth Alignment knob so that the Slide Lever of the Azimuth Alignment Wire is located at the center of the slit of the Azimuth Alignment Wire as shown in Fig. 4.18. After above adjustment, press the Azimuth Alignment Start button to OFF. Record Head Height Adjustment: <ol style="list-style-type: none"> Load a reference SX tape (DA09025A), then press the Record and Play buttons. Press the Level Calibration Start button to oscillate 400 Hz. Adjust Sensitivity Control VR105 (VR205) and Bias Control VR102 (VR202) to the center position. Adjust the RH Height Gear to obtain maximum readings of both channels on the VTVM. Record Head Azimuth Alignment: <ol style="list-style-type: none"> Load a reference SX tape (DA09025A), then press the Record and Play buttons. Press the Bias Calibration Start button to oscillate 15 kHz. Adjust the record Head Azimuth Alignment Screw to obtain maximum readings of both channels on the VTVM. Repeat 2 and 3 one or two times to obtain optimum performance. Azimuth Phase Adjustment: <ol style="list-style-type: none"> Press the Record and Play buttons. Press the Azimuth Alignment Start button to ON, then adjust VR304 on the Main P.C.B. Ass'y so that the red indicator in the middle of the Azimuth Indicator is lit up.
14	Record Level Calibration and Recording Bias Current Adjustment	Tone 400 Hz and 15 kHz and 10 kHz/20 kHz (-20 dB) to Input Jacks	VTVM and Distortion Meter to Output Jacks	Record, Playback Tone - 400 Hz/15 kHz Monitor SW - Tape Tape SW - ZX/SX/EX Eq. SW - 70 μ s (ZX/SX) 120 μ s (EX) Dolby NR SW - C-Type/B-Type/ OFF MPX Filter SW - OUT	Rec. Cal. P.C.B. (Level) ZX: VR106, VR206 SX: VR105, VR205 EX: VR104, VR204 (Bias) ZX: VR101, VR201 SX: VR102, VR202 EX: VR103, VR203	<p>Adjustment should be made in the order of ZX, SX and EX.</p> <ol style="list-style-type: none"> Set the Dolby NR switch to C-Type. Load a reference ZX tape (DA09037A), reference SX tape (DA09025A) and reference EXII tape (DA09066A). Adjust Sensitivity Controls VR106 (VR206) for ZX, VR105 (VR205) for SX and VR104 (VR204) for EXII to the maximum position. Adjust Bias Controls VR101 (VR201) for ZX, VR102 (VR202) for SX and VR103 (VR203) for EXII to the maximum position. Press the Record and Play buttons, then press the Azimuth Alignment Start button to ON. Turn the Azimuth Alignment Knob so that the red indicator in the middle of the Azimuth Indicator is lit up. After above adjustment, press the Azimuth Alignment Start button to OFF. Press the Record and Play buttons, then press the Level Calibration Start button to oscillate 400 Hz. Adjust Sensitivity Controls VR106 (VR206), VR105 (VR205) and VR104 (VR204) to obtain 0 dB on the level meters. Press the Bias Calibration Start button to oscillate 15 kHz. Adjust Bias Controls VR101 (VR201), VR102 (VR202) and VR103 (VR203) to obtain 0 dB on the level meters. Repeat 6 to 9 as above two or three times to obtain optimum performance. Set the Dolby NR switch to B-Type/OFF. Feed in 10 kHz (-20 dB) and 20 kHz (-20 dB), then record and play it back. Check to insure that the levels are within -20 dB \pm 2 dB against the levels in Dolby NR C-Type. Check to insure whether the total harmonic distortion is less than 0.8% for ZX tape and 1.0% for SX and EXII tapes.

STEP	ITEM	SIGNAL SOURCE	OUTPUT CONNECTION	MODE	ADJUSTMENT	REMARKS
15	Overall Frequency Response Adjustment	400 Hz (0 dB) and 20 Hz to 20 kHz (-20 dB) to Input Jacks	VTVM to Output Jacks	Record, Playback Monitor SW - Source/Tape Tape SW - ZX/SX/EX Eq. SW - 70 μ s (ZX/SX) 120 μ s (EX) Dolby NR SW - OFF MPX Filter SW - OUT	Main P.C.B. L101, L201	<ol style="list-style-type: none"> Perform the Azimuth Alignment operation as follows: <ol style="list-style-type: none"> Press the Record and Play buttons. Press the Azimuth Alignment Start button to ON. Turn the Azimuth Alignment Knob so that the red indicator in the middle of the Azimuth Indicator is lit up. After above adjustment, press the Azimuth Alignment Start button to OFF. Set the Monitor switch to Source. Feed in 400 Hz (0 dB) and adjust the Input Level controls to obtain 0 dB on the level meters. Switch the Generator output level to -20 dB. Set the Monitor switch to Tape, then record and play it back. Feed in 20 Hz to 20 kHz (-20 dB), and check to insure whether the output levels are within -20 dB \pm 3 dB. If above is not sufficient, adjust L101 (L201) to obtain approx. -20 dB on the VTVM at 20 kHz. Conduct step 14 "Record Level Calibration and Recording Bias Current Adjustment". If above is not sufficient, precise re-adjustment of step 8 "Playback Frequency Response", replacement of Playback Head or Record Head, check on item 4.10 "Tape Travelling Adjustment" or frequency response adjustment according to item 6.2 will be required.
16	Crosstalk Measurement	1 kHz to Input Jacks	1 kHz Band Pass Filter and VTVM to Output Jacks	Record and Playback Monitor SW - Tape Tape SW - ZX Eq. SW - 70 μ Dolby NR SW - OFF		<ol style="list-style-type: none"> Perform the Azimuth Alignment operation referring to step 15-1. Erase a reference ZX tape with bulk eraser. Adjust the Input Level controls to obtain 0 dB on the level meters, and record the signals on the reference tape. Turn the cassette tape the other way round and play it back. Measure the difference between 3 and 4.
17	Channel Separation Measurement	1 kHz to Input Jacks	Same as above	Same as above		<ol style="list-style-type: none"> Perform the Azimuth Alignment operation referring to step 15-1. Erase a reference ZX tape with bulk eraser. Adjust the L ch (R ch) Input Level control to obtain 0 dB on the level meters, and close the R ch (L ch) Input Level control. Record and play it back, then measure the R ch (L ch) level.
18	Erasure Measurement	1 kHz to Input Jacks	Same as above	Same as above		<ol style="list-style-type: none"> Perform the Azimuth Alignment operation referring to step 15-1. Erase a reference ZX tape with bulk eraser. Adjust the Input Level controls to obtain 0 dB on the level meters, and record the signals on the reference tape. Rewind the tape then close the Input Level controls. Record and play it back, then measure the difference between 3 and 4.
19	Signal to Noise Ratio Measurement	400 Hz to Input Jacks	VTVM and Distortion Meter to Output Jacks	Record and Playback Monitor SW - Tape Tape SW - ZX Eq. SW - 70 μ s Dolby NR SW - B-Type/C-Type		<ol style="list-style-type: none"> Perform the Azimuth Alignment operation referring to step 15-1. Feed in 400 Hz and record and play it back. Adjust the Input Level controls to obtain 3% total harmonic distortion in Playback mode. Close the Input Level controls, then record. After rewind, play back and check the output level difference between 3 and 4. <p>Note: The filter of IHF-A curve shall be used in the measurements.</p>
20	Total Harmonic Distortion Measurement	400 Hz to Input Jacks	Distortion Meter to Output Jacks	Record and Playback Monitor SW - Tape Tape SW - ZX/SX/EX Eq. SW - 70 μ s (ZX/SX) 120 μ s (EX) Dolby NR SW - OFF		<ol style="list-style-type: none"> Perform the Azimuth Alignment operation referring to step 15-1. Adjust the Input Level controls to obtain 0 dB on the level meters. Record and play it back. Read the distortion meter and check to insure that the distortion is less than 0.8% for ZX tape and 1.0% for SX and EXII tapes.
21	Wow/Flutter Measurement	3 kHz Speed and Wow/Flutter Tape (DA09006A)	Wow/Flutter Meter to Output Jacks	Playback Monitor SW - Tape Eq. SW - 70 μ s		Play back and read the wow/flutter meter.

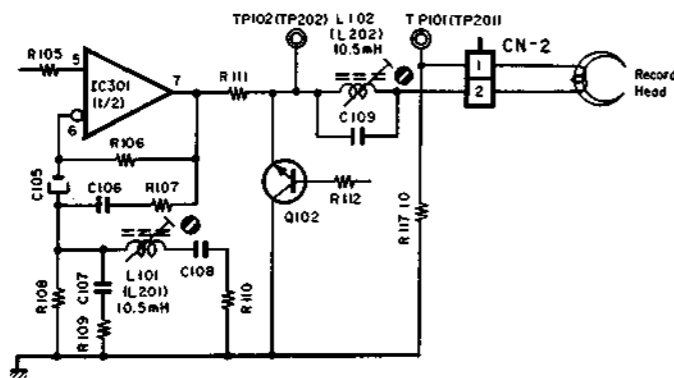

Fig. 6.10
15. Overall Frequency Response

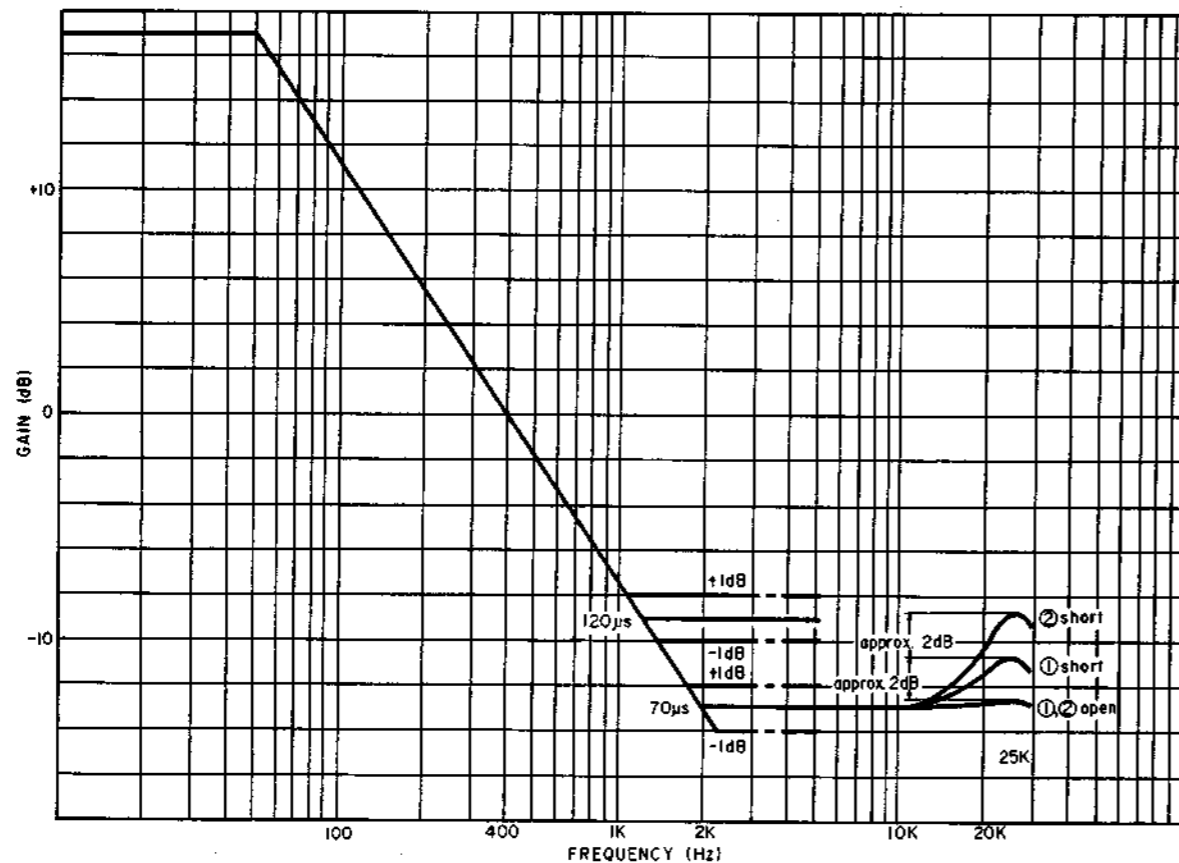

Fig. 6.11 Playback Equalization Curve

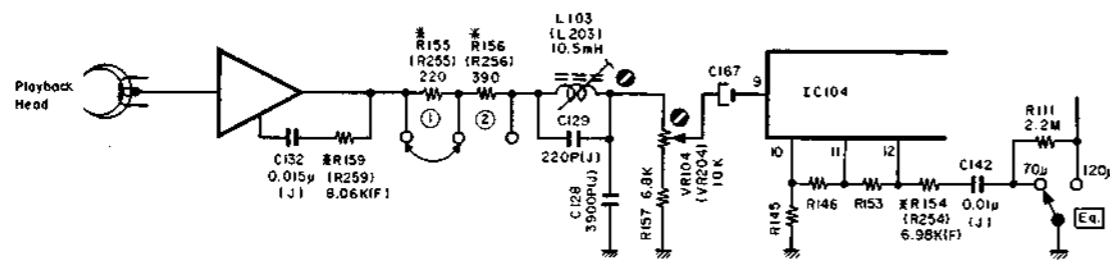

Fig. 6.12 Playback Eq. Amp.

6.2. Frequency Response Adjustment

(1) Playback Frequency Response Adjustment
Refer to Figs. 6.11 and Fig. 6.12.

(a) Level Adjustment (for middle frequency response)

This adjustment will be required if playback level is not sufficient when 10 kHz PB frequency response tape is played back as referred to step 8 in 6.1 "Adjustment and Measurement Instructions".

Playback equalization level is varied by the modification of R159 (R259) on the Main P.C.B. Ass'y and R154 (R254) on the Dolby NR P.C.B. Ass'y.

Following are the details for level modifications:

Approx. +1 dB	R159 (R259): 8.66K
		R154 (R254): 6.49K
0 dB	R159 (R259): 8.06K
		R154 (R254): 6.98K
Approx. -1 dB	R159 (R259): 7.32K
		R154 (R254): 7.87K

(b) Peaking Adjustment (for high frequency response)

This adjustment will be required if playback level is not sufficient when 20 kHz PB frequency response tape is played back as referred to step 8 in 6.1 "Adjustment and Measurement Instructions".

Peaking portion compensates the gap loss of the playback head.

Peaking level is varied by the short circuit of R155 (R255) or R156 (R256) on the Main P.C.B. Ass'y as illustrated in Fig. 6.11.

(2) Record Current Frequency Response Adjustment

Record eq. peaking is adjusted for compensating the overall frequency response when playback frequency response is completed.

Normally however, peaking frequency is pre-adjusted to approx. 23 kHz in Record mode. Refer to Fig. 6.13.

(a) For ZX Tape

1) Feed in 400 Hz (0 dB), then record and play it back. Adjust bias current by VR106 (VR206) on the Record Cal. P.C.B. Ass'y to obtain a 0.8% distortion.

2) Feed in 10 kHz and 400 Hz (-20 dB), then record and play them back.

Check the difference of the levels between 10 kHz and 400 Hz, and mount an additional capacitor in parallel with C101 (C201) on the Main P.C.B. Ass'y from the dip side of the printed circuit board depending upon the difference of the levels against 400 Hz. Refer to Fig. 6.14.

Level Difference	Addition	Total
0 dB	0	1000 pF
-1 dB	330 pF	1330 pF
-2 dB	680 pF	1680 pF

3) Feed in 22 kHz (-20 dB), then record and play it back.

Adjust record peaking coil L101 (L201) to obtain flat overall frequency response.

(b) For SX Tape

1) Feed in 15 kHz and 400 Hz (-20 dB), then record and play them back.

Adjust bias current by VR105 (VR205) on the Record Cal. P.C.B. Ass'y to obtain flat overall frequency response.

2) Feed in 20 kHz and 400 Hz (-20 dB), then record and play them back.

And check to insure that the overall frequency response is flat.

(c) For EXII Tape

1) Feed in 15 kHz and 400 Hz (-20 dB), then record and play them back.

Adjust bias current by VR104 (VR204) on the Record Cal. P.C.B. Ass'y to obtain flat overall frequency response.

2) Feed in 20 kHz and 400 Hz (-20 dB), then record and play them back.

And check to insure that the overall frequency response is flat.

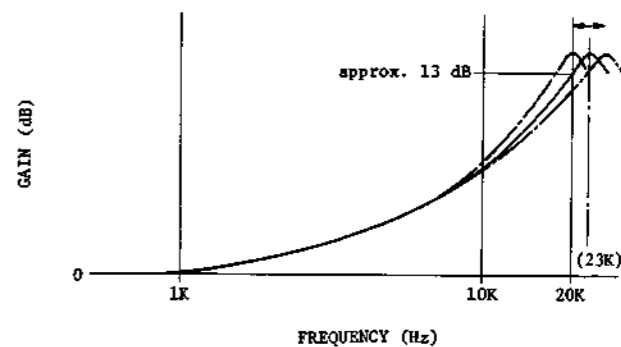

Fig. 6.13

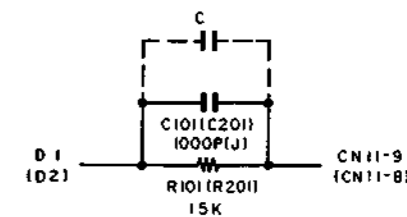

Fig. 6.14

6.3. Dolby NR Circuit Check

Dolby NR circuit incorporates Dolby NR ICs which have no adjustment point.

Perform the following checks and make sure that the IC operates accurately, i.e., accuracy of frequency response through IC.

6.3.1. Dolby NR B-Type Circuit Check

(1) Playback Dolby NR Circuit

Signal Source: 1.4 kHz to pin No. M17 (M18) on Dolby NR P.C.B.

Output Connection: VTVM to MS25 (MS26) on the Dolby NR P.C.B.

Mode: Stop
Monitor SW – Tape
Dolby NR SW – B-Type/OFF

- (a) Connect a VTVM to MS25 (MS26) on the Dolby NR P.C.B. Ass'y.
- (b) Set the Dolby NR switch to B-Type. Feed in 1.4 kHz to pin No. M17 (M18) and adjust the generator output control to obtain 9 mV on the VTVM.
- (c) Set the Dolby NR switch to OFF. Check to insure that the reading is +3.2 dB ±1.5 dB on the VTVM.

(2) Record Dolby NR Circuit

Signal Source: 1.4 kHz to Input Jacks
Output Connection: VTVM to MS25 (MS26) and M1 (M2) on the Dolby NR P.C.B.

Mode: Stop
Monitor SW – Source
Dolby NR SW – B-Type/OFF

- (a) Connect a VTVM to MS25 (MS26) on the Dolby NR P.C.B. Ass'y.
- (b) Feed in 1.4 kHz and adjust the Input Level controls to obtain 9 mV/2.85 mV on the VTVM.
- (c) Remove the VTVM from MS25 (MS26) and reconnect it to M1 (M2) on the Dolby NR P.C.B. Ass'y.
- (d) Check to insure that the reading at M1 (M2) corresponds to the following with Dolby NR switch OFF and B-Type.

Input Level at MS25, MS26	Level at M1 (IC102-16), M2 (IC202-16)	
	Dolby NR OFF	Dolby NR B-Type
9 mV	0 dB	+3.2 dB ±1.5 dB
2.85 mV	0 dB	+8.2 dB ±1.5 dB

6.3.2. Dolby NR C-Type Circuit Check

(1) Playback Dolby NR Circuit

Signal Source: 1.4 kHz to pin No. M17 (M18) on Dolby NR P.C.B.

Output Connection: VTVM to MS25 (MS26) on the Dolby NR P.C.B.

Mode: Stop
Monitor SW – Tape
Dolby NR SW – C-Type/OFF

- (a) Connect a VTVM to MS25 (MS26) on the Dolby NR P.C.B. Ass'y.
- (b) Set the Dolby NR switch to C-Type. Feed in 1.4 kHz to pin No. M17 (M18) and adjust the generator output control to obtain 9 mV on the VTVM.
- (c) Set the Dolby NR switch to OFF. Check to insure that the reading is +6.5 dB ±1.5 dB on the VTVM.

(2) Record Dolby NR Circuit

Signal Source: 1.4 kHz to Input Jacks
Output Connection: VTVM to MS25 (MS26) and M1 (M2) on the Dolby NR P.C.B.

Mode: Stop
Monitor SW – Source
Dolby NR SW – C-Type/OFF

- (a) Connect a VTVM to MS25 (MS26) on the Dolby NR P.C.B. Ass'y.
- (b) Feed in 1.4 kHz and adjust the Input Level controls to obtain 9 mV/2.85 mV on the VTVM.
- (c) Remove the VTVM from MS25 (MS26) and reconnect it to M1 (M2) on the Dolby NR P.C.B. Ass'y.
- (d) Check to insure that the reading at M1 (M2) corresponds to the following with Dolby NR switch OFF and C-Type.

Input Level at MS25, MS26	Level at M1 (IC102-16), M2 (IC202-16)	
	Dolby NR OFF	Dolby NR C-Type
9 mV	0 dB	+6.5 dB ±1.5 dB
2.85 mV	0 dB	+11.4 dB ±1.5 dB

Schematic Ref. No.	Part No.	Description	Schematic Ref. No.	Part No.	Description
	BA04618A	Power Switch P.C.B. Ass'y (U.S.A. & Canada)		BA04642A	Counter Control P.C.B. Ass'y
	BA04594A	Power Switch P.C.B. Ass'y (Japan)		0B02514A	Counter Control P.C.B.
	BA04620A	Power Switch P.C.B. Ass'y (UK, Australia, 220V Class 2 & Others)	IC601	0B06320A	IC LM6402A-048
	0B08956C	Power Switch P.C.B.	X601	0B08908A	Crystal 400 kHz KBR400BT
SW1	0B07407A	Power Switch (U.S.A. & Canada)	R612	0B09749A	Carbon Resistor 1M ERD-16T J
SW1	0B07406A	Power Switch (Japan)	C601,602	0B05879A	Ceramic Capacitor 220P 50V K
SW1	0B07408A	Power Switch (UK, Australia, 220V Class 2 & Others)	C603	0B01836A	Electrolytic Capacitor 47µ 10V
M2	0B08342A	Spark Killer (U.S.A. & Canada)	CN14	0B08939A	7P-H Connector 300mm
M2	0B08363A	Spark Killer (Japan)	CN16	0B08940A	11P-H Connector 300mm
M2	0B08955A	Spark Killer (UK, Australia, 220V Class 2 & Others)	FC601	0B05265A	7P Flat Cable 20mm
	0E00622A	Screw M3x5 Philips Pan Head (2A) (2 pcs.)	FC602	0B05262A	6P Flat Cable 20mm
	0E00752A	Eyelet 2x3 (2 pcs.)		0M04223A	Label CN-16 (1 pce.)
	0J04475A	Power Switch Holder (1 pce.)		0M04231A	Label CN-14 (1 pce.)
	0J04555A	Power Switch Insulator (1 pce.)		BA04551A	Shut-off P.C.B. Ass'y
	BA04547A	Azimuth Switch P.C.B. Ass'y		0B07839B	Shut-off P.C.B.
	0B02511A	Azimuth Switch P.C.B.	Q405	0B06228A	Photo Transistor PH104
	0B07394A	Push Switch (1 pce.)	R604	0B05615A	Carbon Resistor 22K ERD-25T J
	0E00622A	Screw M3x5 Philips Pan Head (2A) (1 pce.)	R605	0B09215A	Fail Safe Type Resistor 100 RDF-25S J
	0J04473A	Adjustment Switch Holder (1 pce.)	PL407	0B08552A	Lamp 12V 25mA
	BA04545A	Record Cal. LED P.C.B. Ass'y	CN13	0B08943A	9P-H Connector Label CN-13 (1 pce.)
	0B02509A	Record Cal. LED P.C.B.		BA04543A	Indicator P.C.B. Ass'y
LED601-609	0B06333A	LED Red TLR124A (9 pcs.)	IC901	0B02505B	Indicator P.C.B.
CN10	0B08923A	6P-H Connector 410mm	Q901	0B06284A	IC MSL9350RS
	0M04227A	Label CN-10 (1 pce.)	Q902,903	0B06066A	Transistor 2SD471
	BA04546A	Volume P.C.B. Ass'y	904,905	0B06202A	Transistor 2SA562 (Y)
	0B02510A	Volume P.C.B.	D901-903	0B01909A	Silicon Diode 1S1555 (3 pcs.)
VR001,002	0B07202A	Volume 100K (A)	R902,903	0B05576A	Carbon Resistor 470 ERD-25T J
VR003	0B07204A	Volume 10K (A) x 2	904,905	0B01704A	Carbon Resistor 68 ERD-25T J (8 pcs.)
	BA04548A	Counter P.C.B. Ass'y	R906-913	0B05784A	Carbon Resistor 560K ERD-25T J
	0B02513B	Counter P.C.B.	R914,915	0B09378A	Fail Safe Type Resistor 22 RSF-1B J
Q601,602	0B06319A	Transistor 2SA608SP	R916	0B09754A	Carbon Resistor 330 ERD-25T J
603,604	0B05629A	Carbon Resistor 2.7K ERD-25T J	R917,919	0B05575A	Carbon Resistor 560 ERD-25T J
R601,602	0B01933A	Carbon Resistor 220 ERD-25T J (7 pcs.)	R918	0B09263A	Carbon Resistor 12K ERD-25T J
603,604	0B06326A	Counter LED SL1405 20	R920	0B05814A	Mylar Capacitor 8200P 50V J
R605-611	0B07219A	Switch AKC8S	C903	0B01838A	Electrolytic Capacitor 47µ 10V
LED601			C904	0B08715A	Thermal Fuse 129
SW601			F901	0B08924B	6P-H Connector 400mm
			CN6	0B05236A	8P Flat Cable (1 pce.)
				0B05264A	Flat Cable 110mm (1 pce.)
				0B06336A	Meter Display (1 pce.)
				0M04334A	Label CN-6 (1 pce.)

7. MOUNTING DIAGRAMS AND PARTS LIST

Note: Mounting diagram shows a dip side view of the printed circuit board.

7.1. Power Switch P.C.B. Ass'y

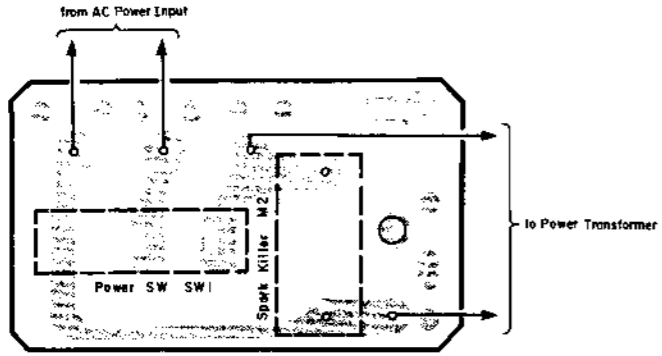

Fig. 7.1

7.2. Azimuth Switch P.C.B. Ass'y

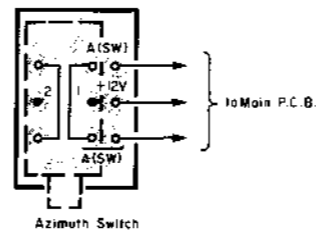

Fig. 7.2

7.7. Shut-off P.C.B. Ass'y

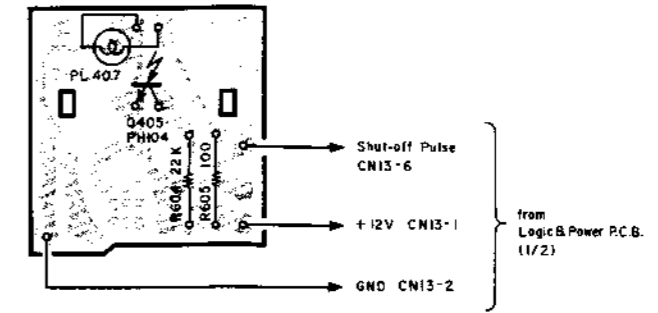

Fig. 7.7

Note: Diode is 1SS53, 1S953, or 1S1555 unless otherwise specified.

7.3. Record Cal. LED P.C.B. Ass'y

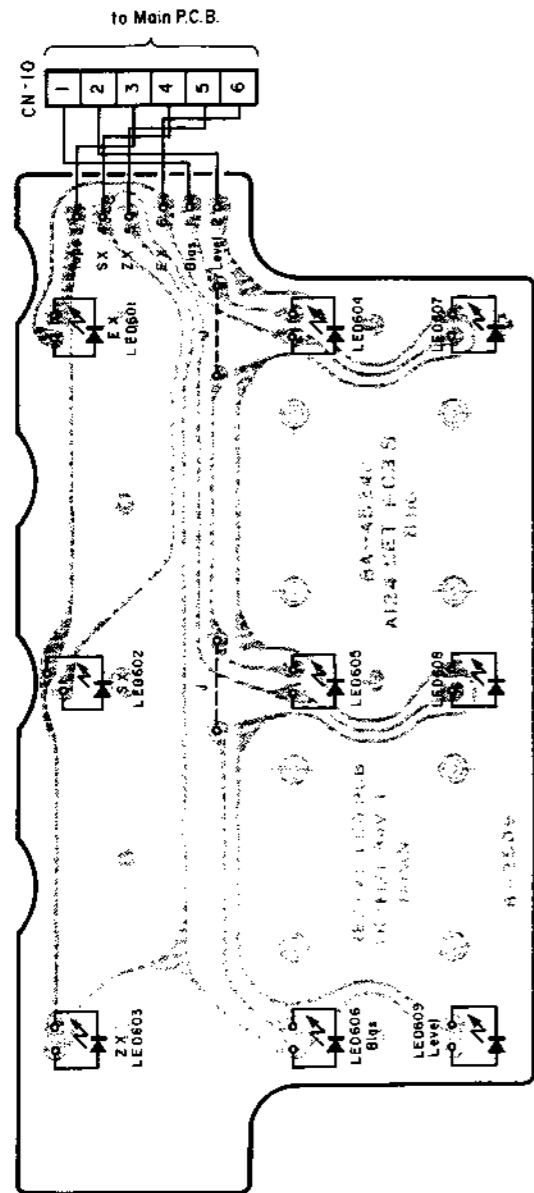

Fig. 7.3

7.4. Volume P.C.B. Ass'y

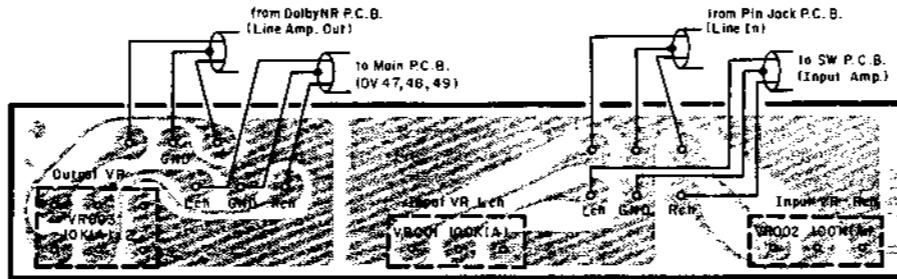

Fig. 7.4

7.5. Counter P.C.B. Ass'y

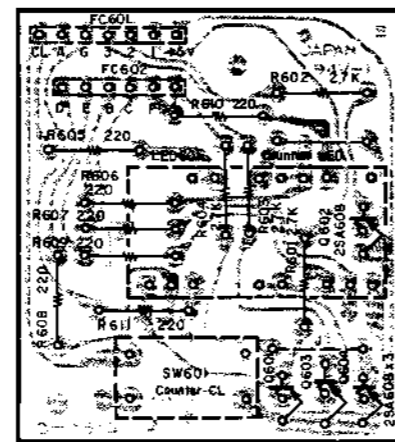

Fig. 7.5

7.6. Counter Control P.C.B. Ass'y

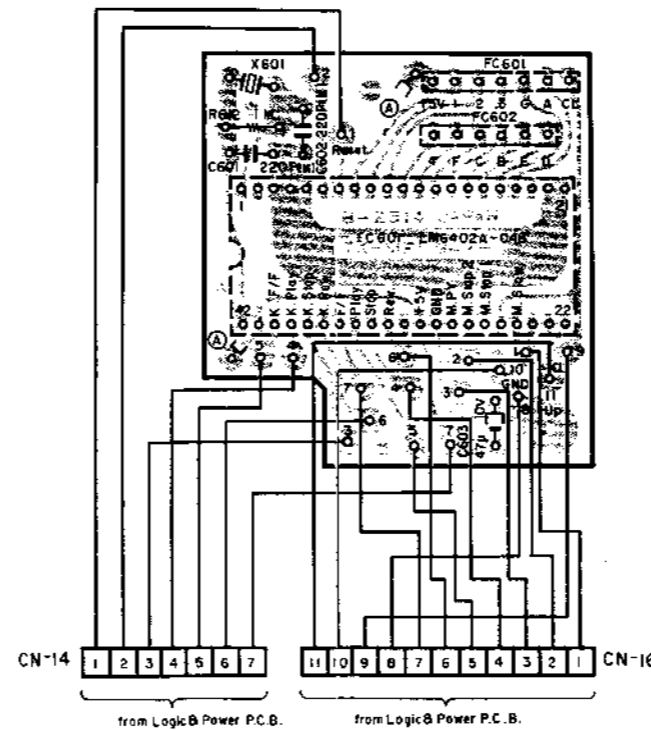

Fig. 7.6

7.8. Indicator P.C.B. Ass'y

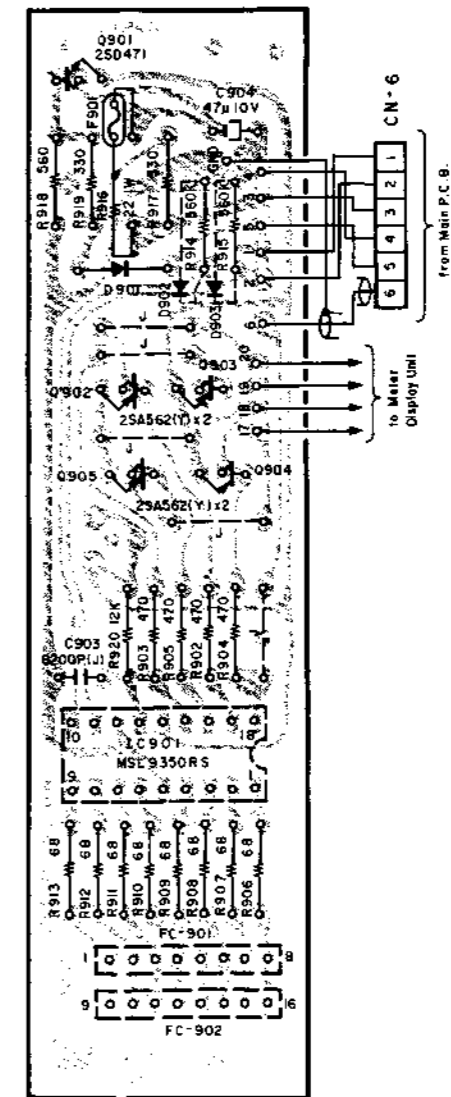

Fig. 7.8

Note: Diode is 1SS53, 1S953, or 1S1555 unless otherwise specified.

7.9. Control Switch P.C.B. Ass'y

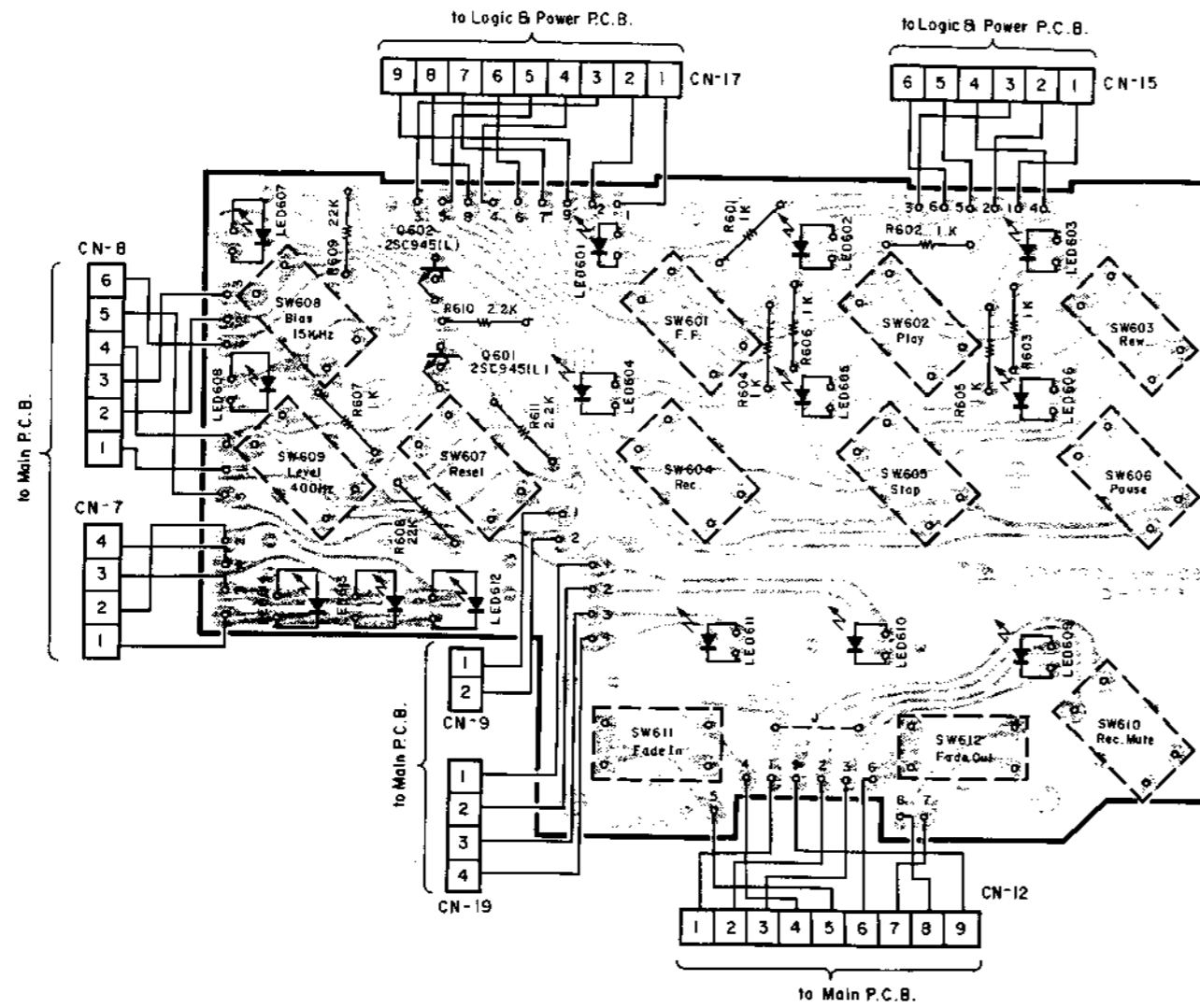

Fig. 7.9

7.10. Record Cal. P.C.B. Ass'y

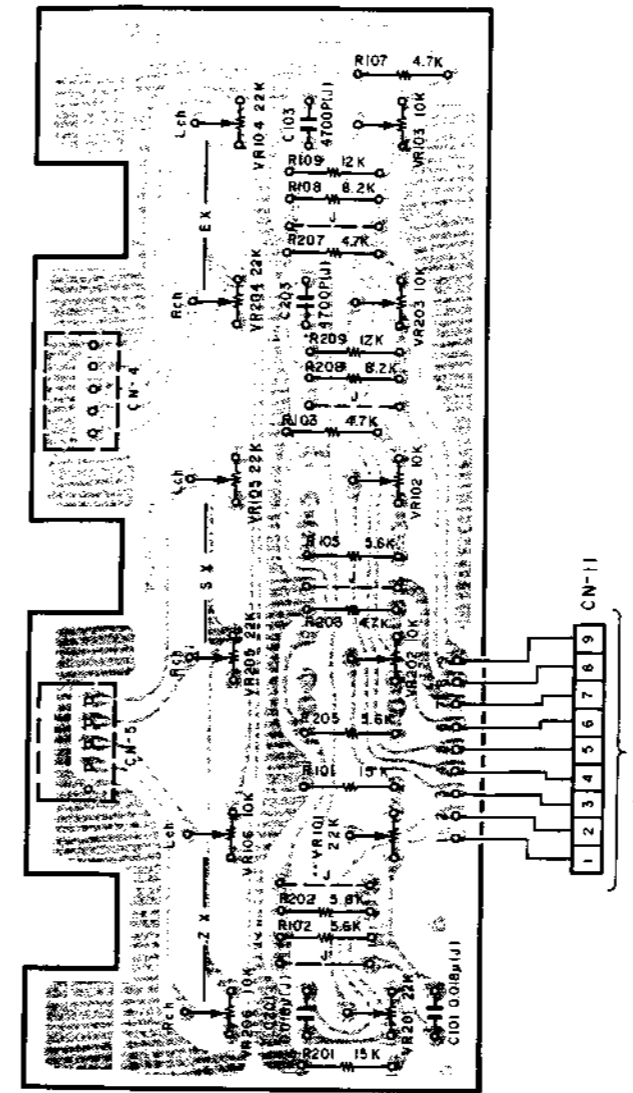

Fig. 7.10

Schematic Ref. No.	Part No.	Description
	BA04544A	Control Switch P.C.B. Ass'y
Q601,602	0B02508C	Control Switch P.C.B.
LED601	0B01872A	Transistor 2SC945 (L)
602,603	0B06334A	LED Green TLG124A
605,606		
612,614		
LED604	0B06333A	LED Red TLR124A
607,608		
609,613		
LED610	0B06327A	LED
611		
R601-607	0B01857A	Carbon Resistor 1K ERD-25T J (7 pcs.)
R608,609	0B05615A	Carbon Resistor 22K ERD-25T J
R610,611	0B05622A	Carbon Resistor 2.2K ERD-25T J
SW601-610	0B07219A	Switch AKCBS (10 pcs.)
SW611,612	0B07396A	Double Action Switch KHF10901
CN7	0B08926A	4P-H Connector 340mm
CN8	0B08922A	6P-H Connector 350mm
CN9	0B08936A	2P-H Connector 430mm
CN12	0B08937A	9P-H Connector 470mm
CN15	0B08938A	6P-H Connector 450mm
CN17	0B08919A	9P-H Connector 450mm
CN19	0B08935A	4P-H Connector 350mm
	0E00857A	BT Screw M3x6 Philips Binding Head (1 pce.)
	0J04534B	Fader House (1 pce.)
	0M04222A	Label CN-15 (1 pce.)
	0M04224A	Label CN-17 (1 pce.)
	0M04225A	Label CN-19 (1 pce.)
	0M04229A	Label CN-12 (1 pce.)
	0M04335A	Label CN-7 (1 pce.)
	0M04336A	Label CN-8 (1 pce.)
	BA04542A	Record Cal. P.C.B. Ass'y
VR101,104	0B02504C	Record Cal. P.C.B.
105,201	0B07277A	Semi-fixed Volume 22K
204,205		
VR102,103	0B07404A	Semi-fixed Volume 10K
106,202		
203,206		
R101,201	0B01683A	Carbon Resistor 15K ERD-25T J
R102,105	0B01887A	Carbon Resistor 5.6K ERD-25T J
202,205		
R103,107	0B01846A	Carbon Resistor 4.7K ERD-25T J
203,207		
R108,208	0B01856A	Carbon Resistor 8.2K ERD-25T J
R109,209	0B09263A	Carbon Resistor 12K ERD-25T J
C101,201	0B05832A	Mylar Capacitor 0.018μ 50V J
C103,203	0B05652A	Mylar Capacitor 4700P 50V J
CN4,5	0B08727A	5P-S Connector
CN11	0B08920A	9P-H Connector 80mm
	0E00612A	Screw M3x6 Philips Pan Head (2A) (2 pcs.)
	0J04481B	Shield Case C (1 pce.)
	0M04228A	Label CN-11 (1 pce.)
	0J04483A	Record Cal. P.C.B. Holder (1 pce.)

7.11. Switch P.C.B. Ass'y

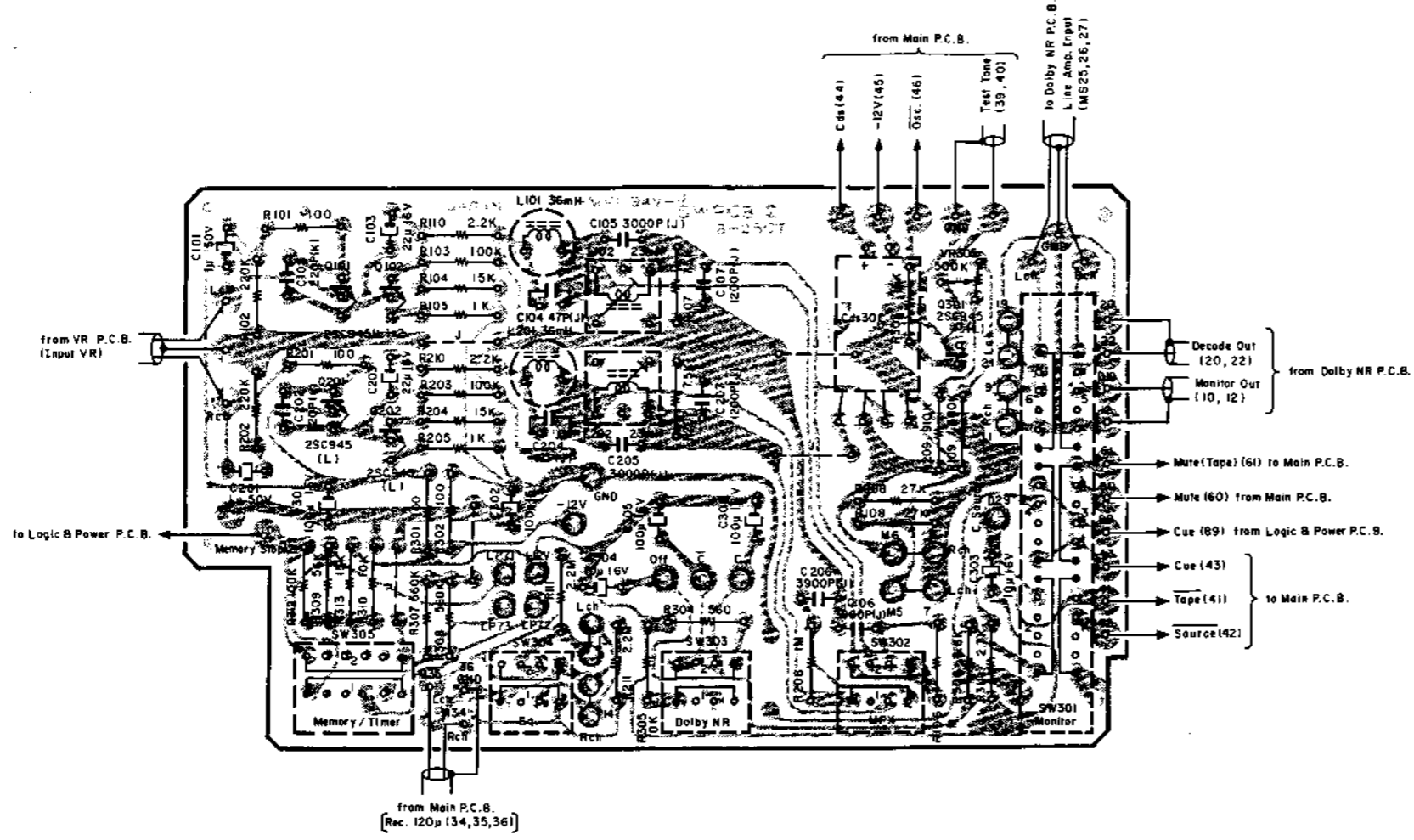

Fig. 7.11

Schematic Ref. No.	Part No.	Description
	BA04554A	Switch P.C.B. Ass'y
Q101,102	0B02507C	Switch P.C.B.
201,202	0B01872A	Transistor 2SC945 (L)
301		
Cds301	0B06325B	Photo Coupler MCD7214F
L101,201	0B03919B	Inductor 36mH
L102,202	0B03563A	19KHz Coil 23mH
VR305	0B07330A	Semi-fixed Volume 500K
R101,201	0B01679A	Carbon Resistor 100 ERD-25T J
R102,202	0B05625A	Carbon Resistor 220K ERD-25T J
R103,203	0B01889A	Carbon Resistor 100K ERD-25T J
312		
R104,204	0B01683A	Carbon Resistor 15K ERD-25T J
303,313		
R105,205	0B01857A	Carbon Resistor 1K ERD-25T J
R106,206	0B05776A	Carbon Resistor 1M ERD-25T J
R107,207	0B09183A	Carbon Resistor 7.5K ERD-25T J
R108,208	0B05743A	Carbon Resistor 27K ERD-25T J
R109	0B05868A	Carbon Resistor 680K ERD-25T J
R110,210	0B05622A	Carbon Resistor 2.2K ERD-25T J
R111,211	0B05671A	Carbon Resistor 2.2M ERD-25T J
R209	0B05960A	Carbon Resistor 910K ERD-25T J
R301,302	0B09215A	Fail Safe Type Resistor 100 RDF-25S J
R304	0B05575A	Carbon Resistor 560 ERD-25T J
R305,310	0B01888A	Carbon Resistor 10K ERD-25T J
R306	0B01887A	Carbon Resistor 5.6K ERD-25T J
R307,308	0B05784A	Carbon Resistor 560K ERD-25T J
R309	0B05508A	Carbon Resistor 56K ERD-25T J
R311	0B05629A	Carbon Resistor 2.7K ERD-25T J
C101,201	0B01405A	Electrolytic Capacitor 1μ 50V
C102,202	0B09283A	Ceramic Capacitor 220P 50V K
C103,203	0B01862A	Electrolytic Capacitor 22μ 16V
C104,204	0B09242A	Mica Capacitor 47P 50V J
C105,205	0B09262A	PP Capacitor 3000P 100V J
C106,206	0B01804A	Mylar Capacitor 3900P 50V J
C107,207	0B05687A	Mylar Capacitor 1200P 50V J
C301,302	0B01400A	Electrolytic Capacitor 100μ 16V
305,306		
C303,304	0B01412A	Electrolytic Capacitor 10μ 16V
SW301	0B07393A	Rotary Switch 6-2NS
SW302,304	0B07392A	Rotary Switch 2-2S
SW303	0B07350A	Rotary Switch 2-3
SW305	0B07391A	Rotary Switch 2-4NS

7.12. Dolby NR P.C.B. Ass'y
7.12.1. Dolby NR P.C.B. Ass'y (U.S.A. & Canada)

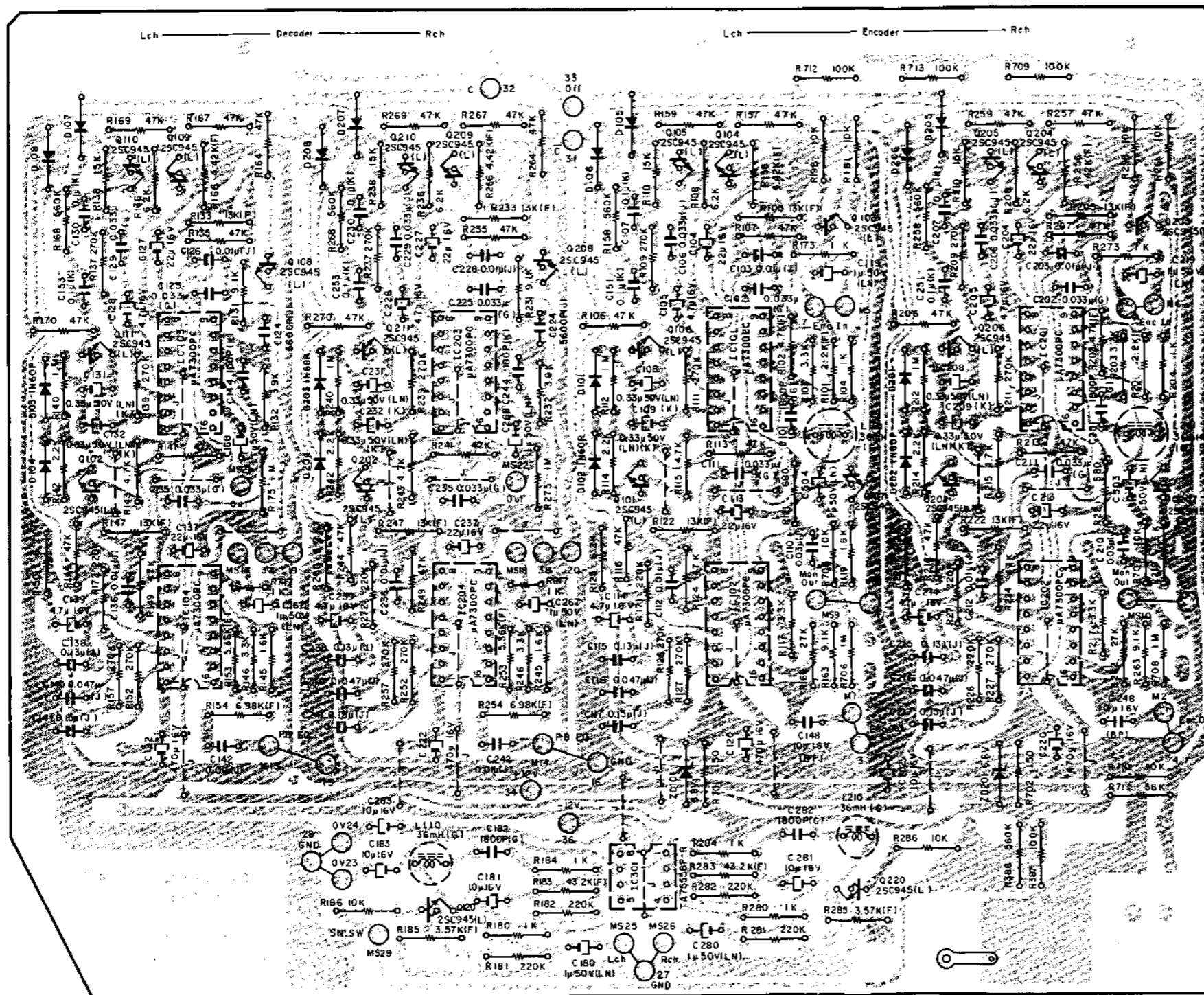

Fig. 7.12.1.1 Serial No.: A12402301 -

Note: Diode is 1S553, 1S953, or 1S1555 unless otherwise specified.

Schematic Ref. No.	Part No.	Description
	BA04575A	Dolby NR P.C.B. Ass'y (U.S.A. & Canada) Serial No.: A12402301 -
		- PB Dolby NR -
IC103,104 203,204	OB06200A	IC μ A7300PC
Q102,108 109,110 111,202 208,209 210,211	OB01872A	Transistor 2SC945 (L)
D103,203 D104,107 108,204 207,208	OB00030A OB01909A	Germanium Diode 1N60P Silicon Diode 1S1555
R131,231 R132,232	OB05694A OB05675A	Carbon Resistor 9.1K ERD-25T J Carbon Resistor 3.9K ERD-25T J
R133,147 233,247	OB09567A	Metal Film Resistor 13K SN14K2E F
R136,141 144,149 164,167 169,170 235,241 244,249 264,267 269,270	OB05641A	Carbon Resistor 47K ERD-25T J
R136,150 236,250	OB09271A	Carbon Resistor 6.2K ERD-25T J
R137,139 152,157 237,239 252,257	OB05620A	Carbon Resistor 270K ERD-25T J
R138,238 R140,175 240,275	OB05591A OB05776A	Carbon Resistor 15K ERD-25T J Carbon Resistor 1M ERD-25T J
R142,242 R143,243 R145,245 R146,246 R153,253 R154,254 R166,266 R168,268 R172,272 R177,817 C122,222 C124,224 C125,135 225,235 C126,136 142,226 236,242 C127,137 227,237 C128,139 228,239 C129,229 C130,153 230,253	OB05622A OB01846A OB09565A OB01681A OB09426A OB09604A OB09558A OB05784A OB05625A OB01857A OB01392A OB05659A OB09240A OB05681A OB01862A OB01389A OB05583A OB01603A	Carbon Resistor 2.2K ERD-25T J Carbon Resistor 4.7K ERD-25T J Carbon Resistor 1.6K ERD-25T J Carbon Resistor 3.3K ERD-25T J Metal Film Resistor 5.36K SN14K2E F Metal Film Resistor 6.98K SN14K2E F Metal Film Resistor 4.42K SN14K2E F Carbon Resistor 560K ERD-25T J Carbon Resistor 220K ERD-25T J Carbon Resistor 1K ERD-25T J Electrolytic Capacitor 470 μ 16V Mylar Capacitor 5600P 50V J PP Capacitor 0.033 μ 100V G Mylar Capacitor 0.01 μ 50V J Electrolytic Capacitor 22 μ 16V Electrolytic Capacitor 4.7 μ 16V Mylar Capacitor 0.033 μ 50V J Mylar Capacitor 0.1 μ 50V K

Schematic Ref. No.	Part No.	Description	Schematic Ref. No.	Part No.	Description
C131,132 231,232	0B09567A	Electrolytic Capacitor 0.33 μ 50V (LN) K	R171,271	0B05625A	Carbon Resistor 220K ERD-25T J
C138,238	0B09566A	Mylar Capacitor 0.13 μ 50V J	R701,702	0B05795A	Carbon Resistor 150 ERD-25T J
C140,240	0B05796A	Mylar Capacitor 0.047 μ 50V J	C101,201	0B09409A	PP Capacitor 1800P 100V G
C141,241	0B05914A	Mylar Capacitor 0.15 μ 50V J	C102,111	0B09240A	PP Capacitor 0.033 μ 100V G
C144,244	0B09282A	Ceramic Capacitor 100P 50V K	202,211		
C167,168 267,268	0B09494A	Electrolytic Capacitor 1 μ 50V (LN)	C103,112	0B05681A	Mylar Capacitor 0.01 μ 50V J
	0B08714A	IC Socket 16P (4 pcs.)	203,212		
	0E00037A	Earth Lug B-5 (1 pcs.)	C104,113	0B01862A	Electrolytic Capacitor 22 μ 16V
	- Rec. Dolby NR -		204,213		
IC101,102 201,202	0B06200A	IC μ A7300PC	C105,114	0B01389A	Electrolytic Capacitor 4.7 μ 16V
Q101,103 104,105 106,107 201,203 204,205 206,207	0B01872A	Transistor 2SC945 (L)	205,214		
ZD101,201	0B06315A	Zener Diode 6.8V XZ068	C106,206	0B05583A	Mylar Capacitor 0.033 μ 50V J
D101,105 106,201 205,206	0B01909A	Silicon Diode 1S1555	C107,151	0B01603A	Mylar Capacitor 0.1 μ 50V K
D102,202	0B00030A	Germanium Diode 1N60P	207,251		
L101,201	0B06676A	Inductor 36mH G	C108,109	0B09567A	Electrolytic Capacitor 0.33 μ 50V (LN) K
R101,201	0B09201A	Metal Film Resistor 2.2K SN14K2E F	208,209		
R102,202	0B09356A	Metal Film Resistor 4.7K SN14K2E F	C110,210	0B09594A	Mylar Capacitor 0.03 μ 50V J
R103,117 203,217	0B01681A	Carbon Resistor 3.3K ERD-25T J	C115,215	0B09566A	Mylar Capacitor 0.13 μ 50V J
R104,173 204,273	0B01857A	Carbon Resistor 1K ERD-25T J	C116,216	0B05796A	Mylar Capacitor 0.047 μ 50V J
R105,122 205,222	0B09557A	Metal Film Resistor 13K SN14K2E F	C117,217	0B05914A	Mylar Capacitor 0.15 μ 50V J
R106,107 113,116 124,157 159,206 207,213 216,224 257,259	0B05641A	Carbon Resistor 47K ERD-25T J	C119,219	0B09223A	Electrolytic Capacitor 1 μ 50V (LN)
R108,125 208,225	0B09271A	Carbon Resistor 6.2K ERD-25T J	503,504		
R109,111 126,127 209,211 226,227	0B05620A	Carbon Resistor 270K ERD-25T J	C120,220	0B01392A	Electrolytic Capacitor 470 μ 16V
R110,210	0B05591A	Carbon Resistor 15K ERD-25T J	C148,248	0B09163A	Electrolytic Capacitor 10 μ 16V (BP)
R112,212 706,708	0B05776A	Carbon Resistor 1M ERD-25T J		0B08714A	IC Socket 16P (4 pcs.)
R114,214	0B05622A	Carbon Resistor 2.2K ERD-25T J		- Line Amp. -	
R115,215	0B01846A	Carbon Resistor 4.7K ERD-25T J	IC301	0B06287A	IC TA75558P-R
R119,219	0B09565A	Carbon Resistor 1.6K ERD-25T J	Q120,220	0B01872A	Transistor 2SC945 (L)
R121,221	0B05794A	Carbon Resistor 680 ERD-25T J	L110,210	0B06676A	Inductor 36mH G
R156,256	0B09558A	Metal Film Resistor 4.42K SN14K2E F	R180,184 280,284	0B01857A	Carbon Resistor 1K ERD-25T J
R158,258	0B05784A	Carbon Resistor 560K ERD-25T J	R181,182 281,282	0B05625A	Carbon Resistor 220K ERD-25T J
R161,198 261,298 705,707	0B01888A	Carbon Resistor 10K ERD-25T J	R183,283	0B09582A	Metal Film Resistor 43.2K SN14K2E F
R162,262	0B05743A	Carbon Resistor 27K ERD-25T J	R185,285	0B09507A	Metal Film Resistor 3.57K SN14K2E F
R163,263	0B05694A	Carbon Resistor 9.1K ERD-25T J	R186,286 710	0B01888A	Carbon Resistor 10K ERD-25T J
			R387,709 712,713	0B01889A	Carbon Resistor 100K ERD-25T J
			R388	0B05784A	Carbon Resistor 560K ERD-25T J
			R711	0B05508A	Carbon Resistor 56K ERD-25T J
			C130,280	0B09223A	Electrolytic Capacitor 1 μ 50V (LN)
			C181,183 281,283 702	0B01412A	Electrolytic Capacitor 10 μ 16V
			C182,282	0B09409A	PP Capacitor 1800P 100V G
				- Miscellaneous -	
				0B07992C	Dolby NR P.C.B.

Schematic Ref. No.	Part No.	Description	Schematic Ref. No.	Part No.	Description
	BA04575A	Dolby NR P.C.B. Ass'y (U.S.A. & Canada) Serial Nos.: A12401001 - A12402300	C131,132 231,232	0B09567A	Electrolytic Capacitor 0.33 μ 50V (LN) K
	- PB Dolby NR -		C138,238 C140,240 C141,241 C144,244 C167,168 267,268	0B09566A 0B05796A 0B05914A 0B09282A 0B09494A	Mylar Capacitor 0.13 μ 50V J Mylar Capacitor 0.047 μ 50V J Mylar Capacitor 0.15 μ 50V J Ceramic Capacitor 100P 50V K Electrolytic Capacitor 1 μ 50V (LN)
IC103,104 203,204 Q102,108 109,110 111,202 208,209 210,211	0B06200A	IC μ A7300PC		0B08714A 0E00037A	IC Socket 16P (4 pcs.) Earth Lug B-5 (1 pce.)
D103,203 D104,107 108,204 207,208	0B00030A 0B01909A	Germanium Diode 1N60P Silicon Diode 1S1555	IC101,102 201,202 Q101,103 104,106 106,107 201,203 204,205 206,207	0B06200A 0B01872A	IC μ A7300PC Transistor 2SC945 (L)
R131,231 R132,232 R133,147 233,247 R135,141 144,149 164,167 169,170 235,241 244,249 264,267 269,270	0B05694A 0B06675A 0B09557A	Carbon Resistor 9.1K ERD-25T J Carbon Resistor 3.9K ERD-25T J Metal Film Resistor 13K SN14K2E F	ZD101,201 D101,105 106,201 205,206 D102,202 L101,201 R101,201 R102,202 R103,117 203,217 R104,173 204,273 R105,122 205,222 R106,107 113,116 124,157 159,206 207,213 216,224 257,259	0B06315A 0B01909A 0B00030A 0B06676A 0B09201A 0B09356A 0B01681A 0B01857A 0B09557A 0B05641A	Zener Diode 6.8V XZ068 Silicon Diode 1S1555 Germanium Diode 1N60P Inductor 36mHG Metal Film Resistor 2.2K SN14K2E F Metal Film Resistor 4.7K SN14K2E F Carbon Resistor 3.3K ERD-25T J Carbon Resistor 1K ERD-25T J Metal Film Resistor 13K SN14K2E F Carbon Resistor 47K ERD-25T J
R136,150 236,250 R137,139 152,157 237,239 252,257 R138,238 R140,175 240,275 R142,242 R143,243 R145,245 R146,246 R153,253 R154,254 R166,266 R168,268 R172,272 R717,817 C122,222 C124,224 C125,135 225,235 C126,136 142,226 236,242 C127,137 227,237 C128,139 228,239 C129,229 C130,153 230,253	0B09271A 0B05620A 0B05591A 0B05776A 0B05622A 0B01846A 0B09565A 0B01681A 0B09426A 0B09604A 0B09558A 0B05784A 0B05625A 0B01857A 0B01392A 0B05659A 0B09240A 0B05681A 0B01862A 0B01389A 0B05583A 0B01603A	Carbon Resistor 6.2K ERD-25T J Carbon Resistor 270K ERD-25T J Carbon Resistor 15K ERD-25T J Carbon Resistor 1M ERD-25T J Carbon Resistor 2.2K ERD-25T J Carbon Resistor 4.7K ERD-25T J Carbon Resistor 1.6K ERD-25T J Carbon Resistor 3.3K ERD-25T J Metal Film Resistor 5.36K SN14K2E F Metal Film Resistor 6.98K SN14K2E F Metal Film Resistor 4.42K SN14K2E F Carbon Resistor 560K ERD-25T J Carbon Resistor 220K ERD-25T J Carbon Resistor 1K ERD-25T J Electrolytic Capacitor 470 μ 16V Mylar Capacitor 5600P 50V J PP Capacitor 0.033 μ 100V G Mylar Capacitor 0.01 μ 50V J Electrolytic Capacitor 22 μ 16V Electrolytic Capacitor 4.7 μ 16V Mylar Capacitor 0.033 μ 50V J Mylar Capacitor 0.1 μ 50V K	R105,122 205,222 R106,107 113,116 124,157 159,206 207,213 216,224 257,259 R108,125 208,225 R109,111 126,127 209,211 226,227 R110,210 R112,212 706,708 R114,214 R115,215 R119,219 R121,221 R156,256 R158,258 R161,198 261,298 705,707 R162,262 R163,263	0B01857A 0B09557A 0B05641A 0B05591A 0B05776A 0B05622A 0B01846A 0B09565A 0B05794A 0B09558A 0B05784A 0B01888A 0B05743A 0B05694A	Carbon Resistor 1K ERD-25T J Metal Film Resistor 13K SN14K2E F Carbon Resistor 47K ERD-25T J Carbon Resistor 15K ERD-25T J Carbon Resistor 1M ERD-25T J Carbon Resistor 2.2K ERD-25T J Carbon Resistor 4.7K ERD-25T J Carbon Resistor 1.6K ERD-25T J Carbon Resistor 680 ERD-25T J Metal Film Resistor 4.42K SN14K2E F Carbon Resistor 560K ERD-25T J Carbon Resistor 10K ERD-25T J Carbon Resistor 27K ERD-25T J Carbon Resistor 9.1K ERD-25T J

Schematic Ref. No.	Part No.	Description
R171,271	0B05625A	Carbon Resistor 220K ERD-25T J
R701,702	0B05795A	Carbon Resistor 150 ERD-25T J
C101,201	0B09409A	PP Capacitor 1800P 100V G
C102,111	0B09240A	PP Capacitor 0.033μ 100V G
202,211		
C103,112	0B05681A	Mylar Capacitor 0.01μ 50V J
203,212		
C104,113	0B01862A	Electrolytic Capacitor 22μ 16V
204,213		
C105,114	0B01389A	Electrolytic Capacitor 4.7μ 16V
205,214		
C106,206	0B05583A	Mylar Capacitor 0.033μ 50V J
C107,151	0B01603A	Mylar Capacitor 0.1μ 50V K
207,251		
C108,109	0B09567A	Electrolytic Capacitor 0.33μ 50V (LN) K
208,209		
C110,210	0B09594A	Mylar Capacitor 0.03μ 50V J
C115,215	0B09566A	Mylar Capacitor 0.13μ 50V J
C116,216	0B05796A	Mylar Capacitor 0.047μ 50V J
C117,217	0B05914A	Mylar Capacitor 0.15μ 50V J
C119,219	0B09223A	Electrolytic Capacitor 1μ 50V (LN)
503,504		
C120,220	0B01392A	Electrolytic Capacitor 470μ 16V
C148,248	0B09163A	Electrolytic Capacitor 10μ 16V (BP)
	0B08714A	IC Socket 16P (4 pcs.)
- Line Amp. -		
IC301	0B06287A	IC TA75558P-R
Q120,220	0B01872A	Transistor 2SC945 (L)
L110,210	0B06676A	Inductor 36mH G
R180,184	0B01857A	Carbon Resistor 1K ERD-25T J
280,284		
R181,182	0B05625A	Carbon Resistor 220K ERD-25T J
281,282		
R183,283	0B09582A	Metal Film Resistor 43.2K SN14K2E F
R185,285	0B09507A	Metal Film Resistor 3.57K SN14K2E F
R186,286	0B01888A	Carbon Resistor 10K ERD-25T J
710		
R387,709	0B01889A	Carbon Resistor 100K ERD-25T J
712,713		
R388	0B05784A	Carbon Resistor 560K ERD-25T J
R711	0B05508A	Carbon Resistor 56K ERD-25T J
C180,280	0B09223A	Electrolytic Capacitor 1μ 50V (LN)
C181,183	0B01412A	Electrolytic Capacitor 10μ 16V
281,283		
702		
C182,282	0B09409A	PP Capacitor 1800P 100V G
- Miscellaneous -		
	0B07992A	Dolby NR P.C.B.

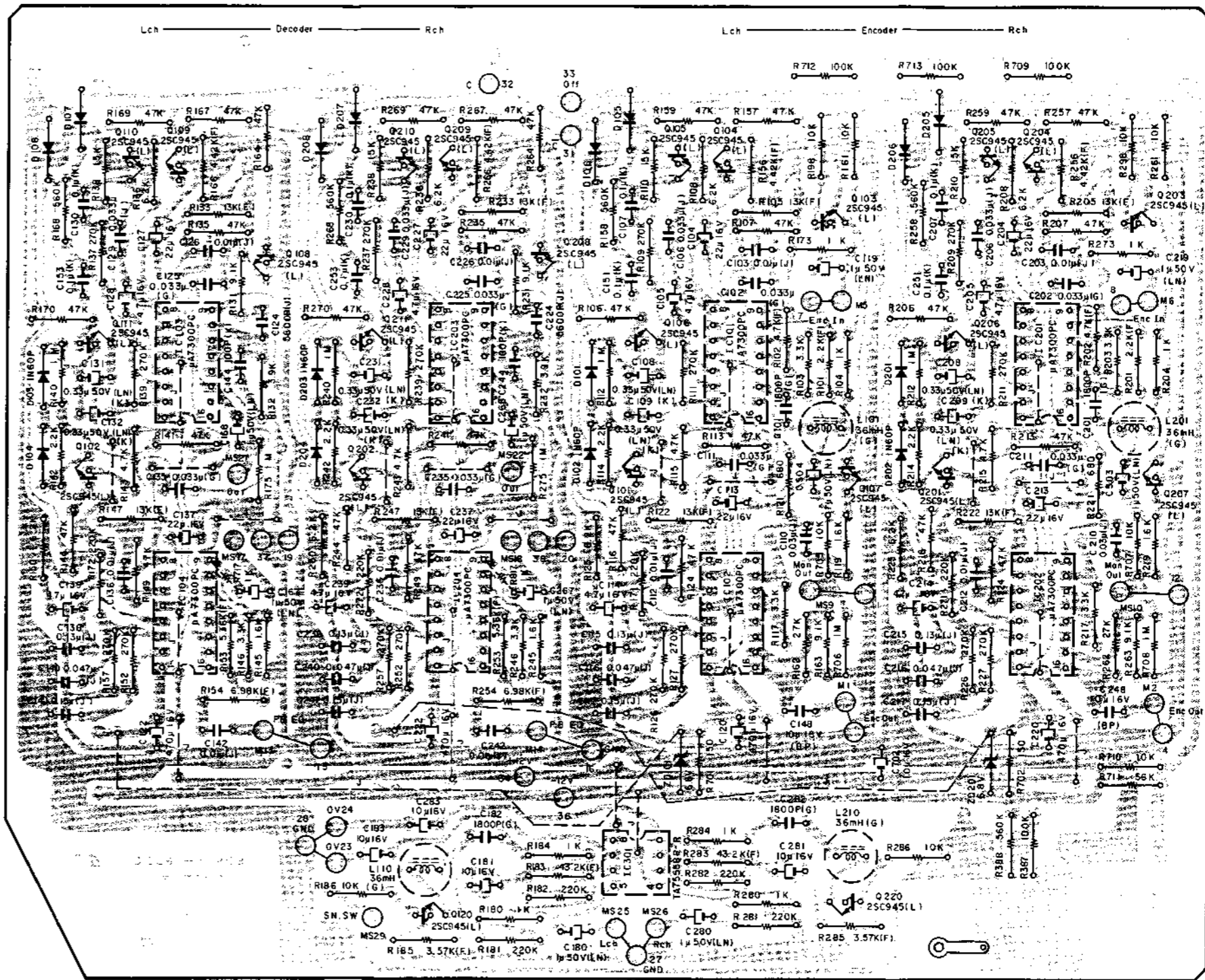

Fig. 7.12.1.2 Serial Nos.: A12401001 - A12402300

Note: Diode is 1S553, 1S953, or 1S1555 unless otherwise specified.

7.12.2. Dolby NR P.C.B. Ass'y (UK, Australia, 220V Class 2, Others & Japan)

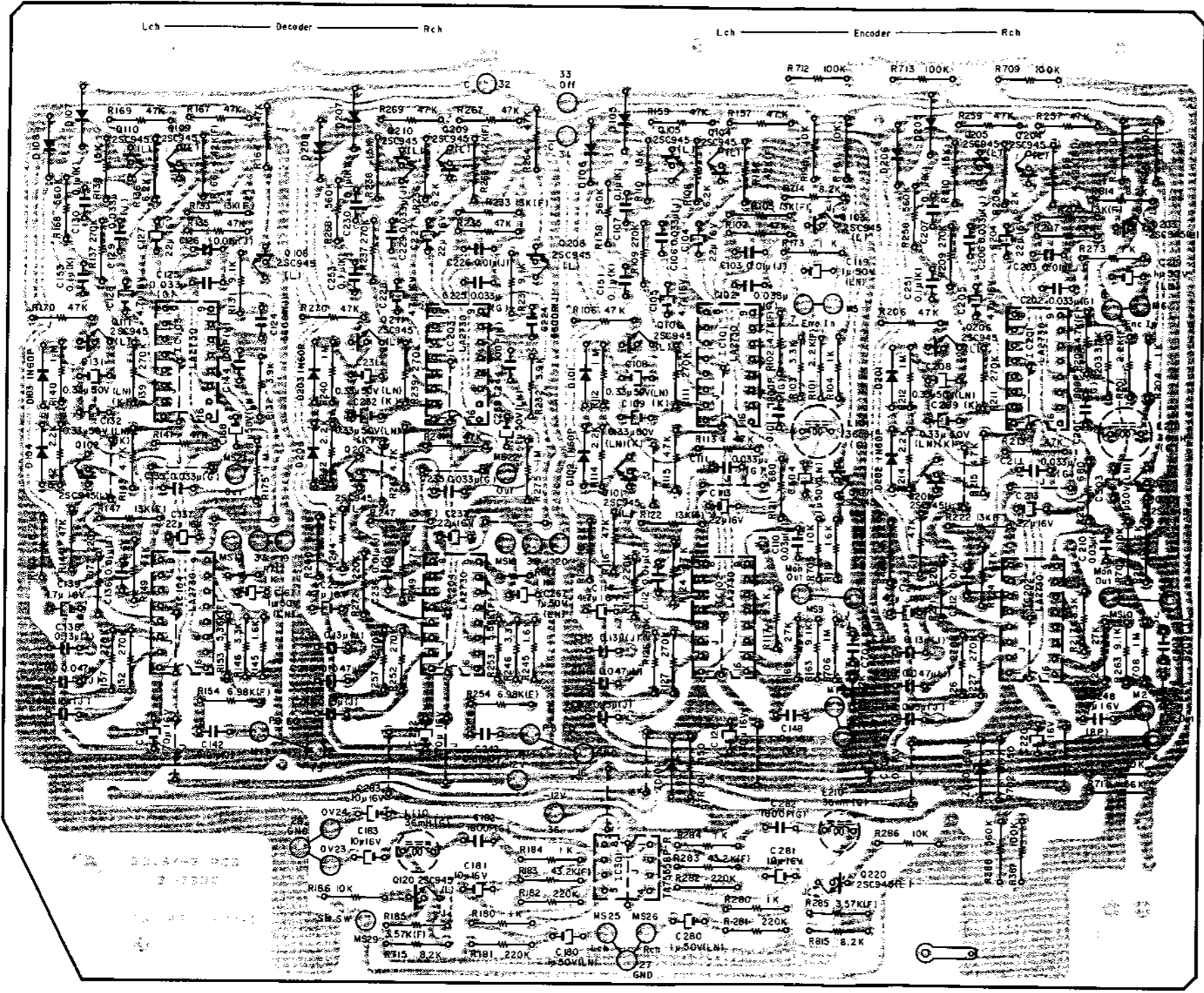

Fig. 7.12.2.1 Serial No.: A12402301 -

Schematic Ref. No.	Part No.	Description
	BA04646A	Dolby NR P.C.B. Ass'y (UK, Australia, 220V Class 2, Others & Japan) Serial No.: A12402301 -
	- PB Dolby NR -	
IC103,104	OB06338A	IC LA2730
Q102,108	OB01872A	Transistor 2SC945 (L)
109,110		
111,202		
208,209		
210,211		
D103,203	OB00030A	Germanium Diode 1N60P
D104,107	OB01909A	Silicon Diode 1S1555
108,204		
207,208		
R131,231	OB05694A	Carbon Resistor 9.1K ERD-25T J
R132,232	OB05675A	Carbon Resistor 3.9K ERD-25T J
R133,147	OB09557A	Metal Film Resistor 13K SN14K2E F
233,247		
R135,141	OB05641A	Carbon Resistor 47K ERD-25T J
144,149		
164,167		
169,170		
235,241		
244,249		
264,267		
269,270		
R136,150	OB09271A	Carbon Resistor 6.2K ERD-25T J
236,250		
R137,139	OB05620A	Carbon Resistor 270K ERD-25T J
152,157		
237,239		
252,257		
R138,238	OB05591A	Carbon Resistor 15K ERD-25T J
R140,175	OB05776A	Carbon Resistor 1M ERD-25T J
240,275		
R142,242	OB05622A	Carbon Resistor 2.2K ERD-25T J
R143,243	OB01846A	Carbon Resistor 4.7K ERD-25T J
R145,245	OB09565A	Carbon Resistor 1.8K ERD-25T J
R146,246	OB01681A	Carbon Resistor 3.3K ERD-25T J
R153,253	OB09426A	Metal Film Resistor 5.36K SN14K2E F
R154,254	OB09604A	Metal Film Resistor 6.98K SN14K2E F
R166,266	OB09558A	Metal Film Resistor 4.42K SN14K2E F
R168,268	OB05784A	Carbon Resistor 560K ERD-25T J
R172,272	OB05625A	Carbon Resistor 220K ERD-25T J
R717,817	OB01857A	Carbon Resistor 1K ERD-25T J
C122,222	OB01392A	Electrolytic Capacitor 470μ 16V
C124,224	OB05659A	Mylar Capacitor 5600P 50V J
C125,135	OB09240A	PP Capacitor 0.033μ 100V G
225,235		
C126,136	OB05681A	Mylar Capacitor 0.01μ 50V J
142,226		
236,242		
C127,137	OB01862A	Electrolytic Capacitor 22μ 16V
227,237		
C128,139	OB01389A	Electrolytic Capacitor 4.7μ 16V
228,239		
C129,229	OB05583A	Mylar Capacitor 0.033μ 50V J
C130,153	OB01603A	Mylar Capacitor 0.1 μ 50V K
230,253		

Schematic Ref. No.	Part No.	Description	Schematic Ref. No.	Part No.	Description
C131,132 231,232	0B09567A	Electrolytic Capacitor 0.33μ 50V (LN) K	R163,263	0B05694A	Carbon Resistor 9.1K ERD-25T J
C138,238	0B09566A	Mylar Capacitor 0.13μ 50V J	R171,271	0B05625A	Carbon Resistor 220K ERD-25T J
C140,240	0B05796A	Mylar Capacitor 0.047μ 50V J	R701,702	0B09213A	Fail Safe Type Resistor 150 RDF-25S J
C141,241	0B05914A	Mylar Capacitor 0.15μ 50V J	R714,814	0B01856A	Carbon Resistor 8.2K ERD-25T J
C144,244	0B09282A	Ceramic Capacitor 100P 50V K	C101,201	0B09409A	PP Capacitor 1800P 100V G
C167,168 267,268	0B09494A	Electrolytic Capacitor 1μ 50V (LN)	C102,111 202,211	0B09240A	PP Capacitor 0.033μ 100V G
	0B08714A	IC Socket 16P (4 pcs.)	C103,112	0B05681A	Mylar Capacitor 0.01μ 50V J
	0E00037A	Earth Lug B-5 (1 pce.)	C104,113 203,212	0B01862A	Electrolytic Capacitor 22μ 16V
	- Rec. Dolby NR -		C104,113 204,213	0B01389A	Electrolytic Capacitor 4.7μ 16V
IC101,102 201,202	0B06338A	IC LA2730	C105,114 205,214	0B05583A	Mylar Capacitor 0.033μ 50V J
Q101,103 104,105 106,107 201,203 204,205 206,207	0B01872A	Transistor 2SC945 (L)	C106,206 C107,151 207,251	0B01603A	Mylar Capacitor 0.1μ 50V K
ZD101,201	0B06315A	Zener Diode 6.8V XZ068	C108,109 208,209	0B09567A	Electrolytic Capacitor 0.33μ 50V (LN) K
D101,105 106,201 205,206	0B01909A	Silicon Diode 1S1555	C110,210 C115,215 C116,216 C117,217 C119,219 503,504	0B09594A	Mylar Capacitor 0.03μ 50V J
D102,202	0B00030A	Germanium Diode 1N60P	C118,216 C119,219 503,504	0B09566A	Mylar Capacitor 0.13μ 50V J
L101,201	0B06676A	Inductor 36mH G	C120,220 C148,248 C703,803	0B05796A	Mylar Capacitor 0.047μ 50V J
R101,201	0B09201A	Metal Film Resistor 2.2K SN14K2E F		0B05914A	Mylar Capacitor 0.15μ 50V J
R102,202	0B09356A	Metal Film Resistor 4.7K SN14K2E F		0B09223A	Electrolytic Capacitor 1μ 50V (LN)
R103,117 203,217	0B01681A	Carbon Resistor 3.3K ERD-25T J		0B01392A	Electrolytic Capacitor 470μ 16V
R104,173 204,273	0B01857A	Carbon Resistor 1K ERD-25T J		0B09163A	Electrolytic Capacitor 10μ 16V (BP)
R105,122 205,222	0B09557A	Metal Film Resistor 13K SN14K2E F		0B09783A	PP Capacitor 820P 100V J
R106,107 113,116 124,157 159,206 207,213 216,224 257,259	0B05641A	Carbon Resistor 47K ERD-25T J		0B08714A	IC Socket 16P (4 pcs.)
R108,125 208,225	0B09271A	Carbon Resistor 6.2K ERD-25T J		- Line Amp. -	
R109,111 126,127 209,211 226,227	0B05620A	Carbon Resistor 270K ERD-25T J	IC301	0B06287A	IC TA75558P-R
R110,210	0B05591A	Carbon Resistor 15K ERD-25T J	Q120,220	0B01872A	Transistor 2SC945 (L)
R112,212 706,708	0B05776A	Carbon Resistor 1M ERD-25T J	L110,210	0B06676A	Inductor 36mH G
R114,214	0B05622A	Carbon Resistor 2.2K ERD-25T J	R180,184 280,284	0B01857A	Carbon Resistor 1K ERD-25T J
R115,215	0B01846A	Carbon Resistor 4.7K ERD-25T J	R181,182 281,282	0B05625A	Carbon Resistor 220K ERD-25T J
R119,219	0B09565A	Carbon Resistor 1.6K ERD-25T J	R183,283	0B09582A	Metal Film Resistor 43.2K SN14K2E F
R121,221	0B05794A	Carbon Resistor 680 ERD-25T J	R185,285	0B09507A	Metal Film Resistor 3.57K SN14K2E F
R154,254	0B05615A	Carbon Resistor 22K ERD-25T J	R186,286 710	0B01888A	Carbon Resistor 10K ERD-25T J
R156,256	0B09558A	Metal Film Resistor 4.42K SN14K2E F	R387,709 712,713	0B01889A	Carbon Resistor 100K ERD-25T J
R158,258	0B05784A	Carbon Resistor 560K ERD-25T J	R388	0B05784A	Carbon Resistor 560K ERD-25T J
R161,198 261,298 705,707	0B01888A	Carbon Resistor 10K ERD-25T J	R711	0B05508A	Carbon Resistor 56K ERD-25T J
R162,262	0B05743A	Carbon Resistor 27K ERD-25T J	R715,815	0B01856A	Carbon Resistor 8.2K ERD-25T J
			C180,280	0B09223A	Electrolytic Capacitor 1μ 50V (LN)
			C181,183 281,283 702	0B01412A	Electrolytic Capacitor 10μ 16V
			C182,282	0B09409A	PP Capacitor 1800P 100V G
				- Miscellaneous -	
				0B07992C	Dolby NR P.C.B.

Schematic Ref. No.	Part No.	Description	Schematic Ref. No.	Part No.	Description
	BA04646A	Dolby NR P.C.B. Ass'y (UK, Australia, 220V Class 2, Others & Japan) Serial Nos.: A12401001 - A12402300	C131,132 231,232 C138,238 C140,240 C141,241 C144,244 C167,168 267,268	0B09567A	Electrolytic Capacitor 0.33 μ 50V (LN) K
	- PB Dolby NR -			0B09566A	Mylar Capacitor 0.13 μ 50V J
IC* 33,104 203,204	0B06338A	IC LA2730		0B05796A	Mylar Capacitor 0.047 μ 50V J
Q102,108 109,110 111,202 208,209 210,211	0B01872A	Transistor 2SC945 (L)		0B05914A	Mylar Capacitor 0.15 μ 50V J
D103,203	0B00030A	Germanium Diode 1N60P		0B09282A	Ceramic Capacitor 100P 50V K
D104,107 108,204 207,208	0B01909A	Silicon Diode 1S1555		0B09494A	Electrolytic Capacitor 1 μ 50V (LN)
R131,231	0B05694A	Carbon Resistor 9.1K ERD-25T J		0B08714A	IC Socket 16P (4 pcs.)
R132,232	0B05675A	Carbon Resistor 3.9K ERD-25T J		0E00037A	Earth Lug B-5 (1 pce.)
R133,147 233,247	0B09557A	Metal Film Resistor 13K SN14K2E F		- Rec. Dolby NR -	
R135,141 144,149 164,167 169,170 235,241 244,249 264,267 269,270	0B05641A	Carbon Resistor 47K ERD-25T J	IC101,102 201,202	0B06338A	IC LA2730
R136,150 236,250	0B09271A	Carbon Resistor 6.2K ERD-25T J	Q101,103 104,105 106,107 201,203 204,205 206,207	0B01872A	Transistor 2SC945 (L)
R137,139 152,157 237,239 252,257	0B05620A	Carbon Resistor 270K ERD-25T J	ZD101,201	0B06315A	Zener Diode 6.8V XZ068
R138,238	0B05591A	Carbon Resistor 15K ERD-25T J	D101,105 106,201 205,206	0B01909A	Silicon Diode 1S1555
R140,175 240,275	0B05776A	Carbon Resistor 1M ERD-25T J	D102,202 L101,201	0B00030A	Germanium Diode 1N60P
R142,242	0B05622A	Carbon Resistor 2.2K ERD-25T J	R101,201	0B06676A	Inductor 36mH G
R143,243	0B01846A	Carbon Resistor 4.7K ERD-25T J	R102,202	0B09201A	Metal Film Resistor 2.2K SN14K2E F
R145,245	0B09565A	Carbon Resistor 1.6K ERD-25T J	R103,117 203,217	0B09356A	Metal Film Resistor 4.7K SN14K2E F
R146,246	0B01681A	Carbon Resistor 3.3K ERD-25T J	R104,173 204,273	0B01681A	Carbon Resistor 3.3K ERD-25T J
R153,253	0B09426A	Metal Film Resistor 5.36K SN14K2E F	R105,122 205,222	0B01857A	Carbon Resistor 1K ERD-25T J
R154,254	0B09604A	Metal Film Resistor 6.98K SN14K2E F	R106,107 113,116 124,157 159,206 207,213 216,224 257,259	0B09557A	Metal Film Resistor 13K SN14K2E F
R166,266	0B09568A	Metal Film Resistor 4.42K SN14K2E F	R108,125 208,225	0B0557A	Carbon Resistor 47K ERD-25T J
R168,268	0B05784A	Carbon Resistor 560K ERD-25T J	R109,111 126,127 209,211 226,227	0B09271A	Carbon Resistor 6.2K ERD-25T J
R172,272	0B05625A	Carbon Resistor 220K ERD-25T J	R110,210	0B05620A	Carbon Resistor 270K ERD-25T J
R717,817	0B01857A	Carbon Resistor 1K ERD-25T J	R112,212 706,708	0B05591A	Carbon Resistor 15K ERD-25T J
C122,222	0B01392A	Electrolytic Capacitor 470 μ 16V	R114,214	0B05776A	Carbon Resistor 1M ERD-25T J
C124,224	0B05659A	Mylar Capacitor 5600P 50V J	R115,215	0B05622A	Carbon Resistor 2.2K ERD-25T J
C125,135 225,235	0B09240A	PP Capacitor 0.033 μ 100V G	R119,219	0B01846A	Carbon Resistor 4.7K ERD-25T J
C126,136 142,226 236,242	0B05681A	Mylar Capacitor 0.01 μ 50V J	R121,221	0B09565A	Carbon Resistor 1.6K ERD-25T J
C127,137 227,237	0B01862A	Electrolytic Capacitor 22 μ 16V	R154,254	0B05794A	Carbon Resistor 680 ERD-25T J
C128,139 228,239	0B01389A	Electrolytic Capacitor 4.7 μ 16V	R156,256	0B05615A	Carbon Resistor 22K ERD-25T J
C129,229	0B05583A	Mylar Capacitor 0.033 μ 50V J	R158,258	0B09558A	Metal Film Resistor 4.42K SN14K2E F
C130,153 230,263	0B01603A	Mylar Capacitor 0.1 μ 50V K	R161,198 261,298 705,707 R162,262	0B05784A	Carbon Resistor 560K ERD-25T J
				0B01888A	Carbon Resistor 10K ERD-25T J
				0B05743A	Carbon Resistor 27K ERD-25T J

Schematic Ref. No.	Part No.	Description
R163,263	0B05694A	Carbon Resistor 9.1K ERD-25T J
R171,271	0B05625A	Carbon Resistor 220K ERD-25T J
R701,702	0B09213A	Fail Safe Type Resistor 150 RDF-25S J
R714,814	0B01856A	Carbon Resistor 8.2K ERD-25T J
C101,201	0B09409A	PP Capacitor 1800P 100V G
C102,111	0B09240A	PP Capacitor 0.033μ 100V G
202,211		
C103,112	0B05681A	Mylar Capacitor 0.01μ 50V J
203,212		
C104,113	0B01862A	Electrolytic Capacitor 22μ 16V
204,213		
C105,114	0B01389A	Electrolytic Capacitor 4.7μ 16V
205,214		
C106,206	0B05583A	Mylar Capacitor 0.033μ 50V J
C107,151	0B01603A	Mylar Capacitor 0.1μ 50V K
207,251		
C108,109	0B09567A	Electrolytic Capacitor 0.33μ 50V (LN) K
208,209		
C110,210	0B09594A	Mylar Capacitor 0.03μ 50V J
C115,215	0B09566A	Mylar Capacitor 0.13μ 50V J
C116,216	0B05796A	Mylar Capacitor 0.047μ 50V J
C117,217	0B05914A	Mylar Capacitor 0.15μ 50V J
C119,219	0B09223A	Electrolytic Capacitor 1μ 50V (LN)
503,504		
C120,220	0B01392A	Electrolytic Capacitor 470μ 16V
C148,248	0B09163A	Electrolytic Capacitor 10μ 16V (BP)
C703,803	0B09783A	PP Capacitor 820P 100V J
	0B08714A	IC Socket 16P (4 pcs.)
- Line Amp. -		
IC301	0B06287A	IC TA75558P-R
Q120,220	0B01872A	Transistor 2SC945 (L)
L110,210	0B06676A	Inductor 36mH G
R180,184	0B01857A	Carbon Resistor 1K ERD-25T J
280,284		
R181,182	0B05625A	Carbon Resistor 220K ERD-25T J
281,282		
R183,283	0B09582A	Metal Film Resistor 43.2K SN14K2E F
R185,285	0B09507A	Metal Film Resistor 3.57K SN14K2E F
R186,286	0B01888A	Carbon Resistor 10K ERD-25T J
710		
R387,709	0B01889A	Carbon Resistor 100K ERD-25T J
712,713		
R388	0B05784A	Carbon Resistor 560K ERD-25T J
R711	0B05508A	Carbon Resistor 56K ERD-25T J
R715,815	0B01856A	Carbon Resistor 8.2K ERD-25T J
C180,280	0B09223A	Electrolytic Capacitor 1μ 50V (LN)
C181,183	0B01412A	Electrolytic Capacitor 10μ 16V
281,283		
702		
C182,282	0B09409A	PP Capacitor 1800P 100V G
- Miscellaneous -		
0B07992A		Dolby NR P.C.B.

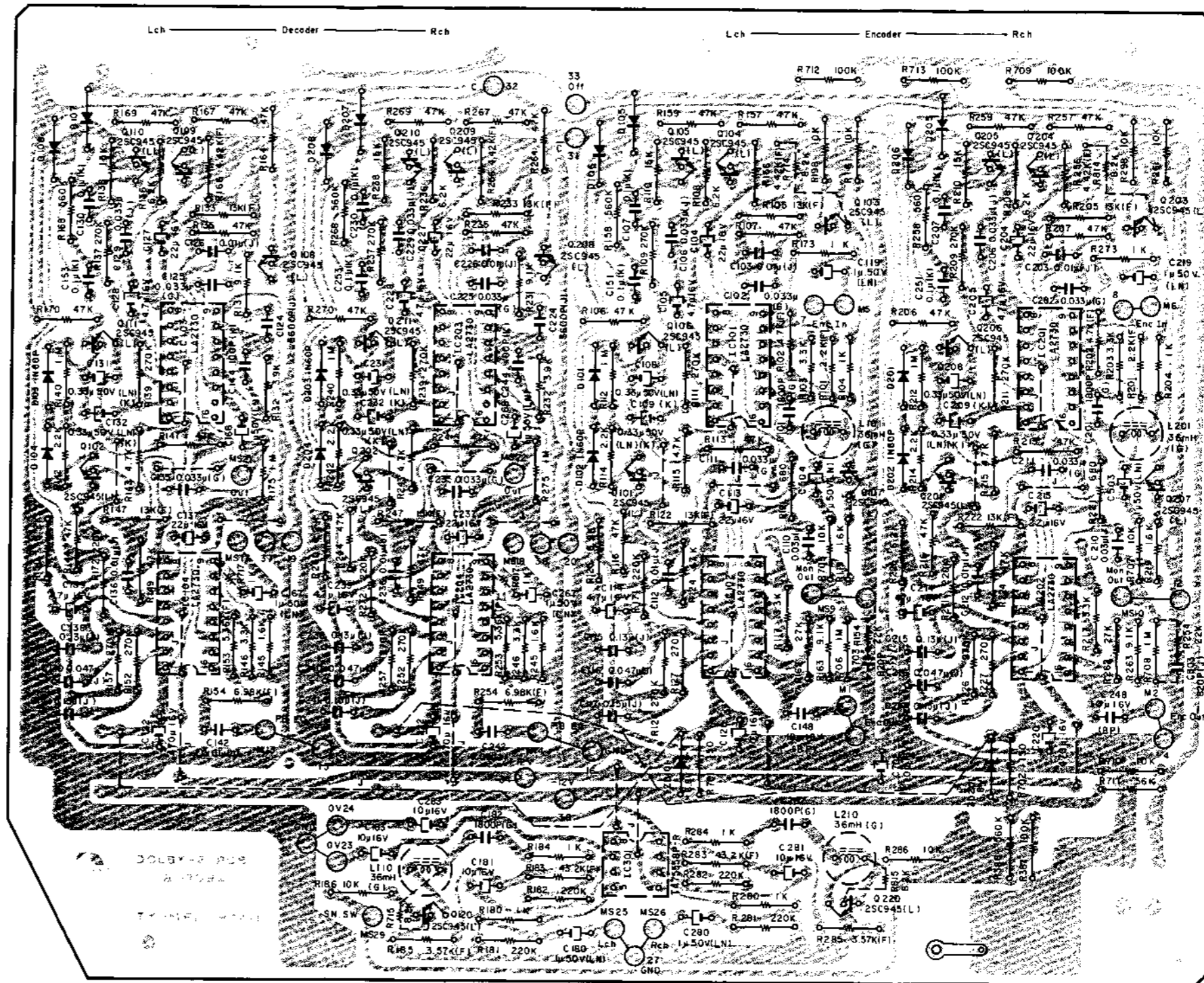

Fig. 7.12.2.2 Serial Nos.: A12401001 - A12402300

Note: Diode is 1S553, 1S953, or 1S1555 unless otherwise specified.

7.13. Logic & Power P.C.B. Ass'y

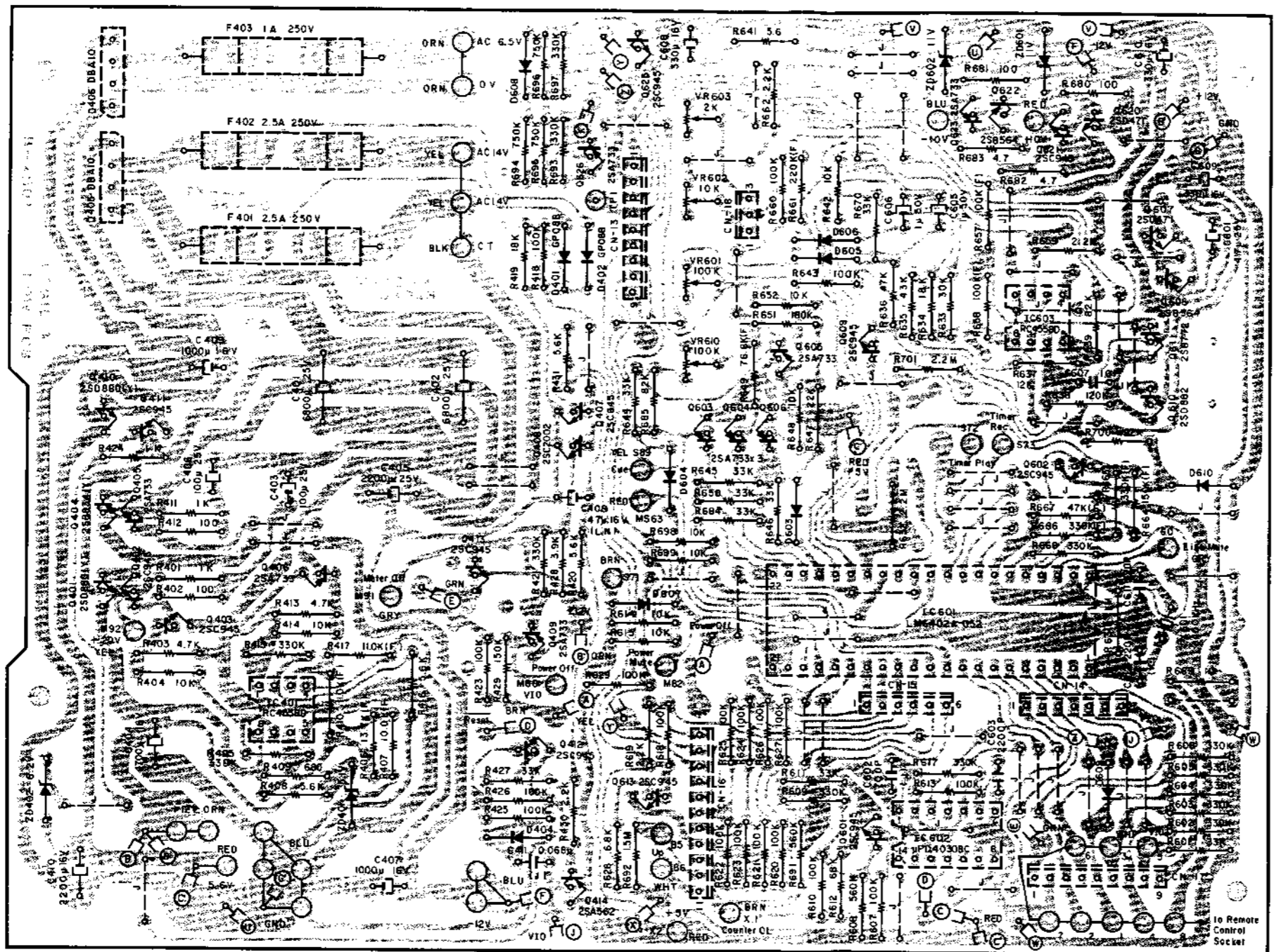

Fig. 7.13.1 Serial No.: A12402301 — Note: Diode is 1SS53, 1S953, or 1S1555 unless otherwise specified.

Schematic Ref. No.	Part No.	Description	
	BA04622A BA04621A BA04623A	Logic & Power P.C.B. Ass'y (U.S.A., Canada & Others) Logic & Power P.C.B. Ass'y (Japan) Logic & Power P.C.B. Ass'y (UK, Australia & 220V Class 2) Serial No.: A12402301 —	
	— DC Supply —		
IC401	OB06124B	IC	RC4558D
Q402,403 407,411 412,413	OB06100A	Transistor	2SC945 (A)
Q405,406 409	OB06013A	Transistor	2SA733
Q408	OB06322A	Transistor	2SC2002
Q414	OB01426A	Transistor	2SA562
ZD401	OB06058A	Zener Diode 5.1V	YZ051
ZD402	OB06314A	Zener Diode 6.2V	YZ062
D401,402	OB06109A	Silicon Diode	GP088
D404	OB01909A	Silicon Diode	1S1555
D405,406	OB06282A	Diode Bridge	DBA10
R401,411 424	OB01857A	Carbon Resistor	1K ERD-25T J
R402,412	OB01679A	Carbon Resistor	100 ERD-25T J
R403,413	OB01846A	Carbon Resistor	4.7K ERD-25T J
R404,414	OB01888A	Carbon Resistor	10K ERD-25T J
R405,415	OB05627A	Carbon Resistor	330K ERD-25T J
R406	OB09528A	Metal Film Resistor	13.7K SN14K2E F
R407	OB09203A	Metal Film Resistor	10K SN14K2E F
R408,416 420,431	OB01887A	Carbon Resistor	5.6K ERD-25T J
R409	OB05794A	Carbon Resistor	680 ERD-25T J
R410,417	OB09128A	Metal Film Resistor	11K SN14K2E F
R418,423 425,426	OB01889A	Carbon Resistor	100K ERD-25T J
R419	OB05560A	Carbon Resistor	18K ERD-25T J
R427	OB05509A	Carbon Resistor	33K ERD-25T J
R428	OB05675A	Carbon Resistor	3.9K ERD-25T J
R429	OB05626A	Carbon Resistor	150K ERD-25T J
R430	OB05622A	Carbon Resistor	2.2K ERD-25T J
C401,402	OB09374A	Electrolytic Capacitor	6800μ 25V
C403,406	OB01272A	Electrolytic Capacitor	100μ 25V
C404	OB09377A	Electrolytic Capacitor	4700μ 16V
C405	OB05654A	Electrolytic Capacitor	2200μ 25V
C407,409	OB01397A	Electrolytic Capacitor	1000μ 16V
C408	OB09218A	Electrolytic Capacitor	47μ 16V (LN)
C410	OB01406A	Electrolytic Capacitor	2200μ 16V
C411	OB05682A	Mylar Capacitor	0.068μ 50V J
	— Logic —		
IC601	OB06324A	IC	LM6402A-052
IC602	OB06317A	IC	μPD4030BC
IC603	OB06124B	IC	RC4558D
Q601,602 609,613 621,625	OB06100A	Transistor	2SC945 (A)
Q603,604 605,606 623,626	OB06013A	Transistor	2SA733
Q607,620	OB06066A	Transistor	2SD471

Schematic Ref. No.	Part No.	Description	Schematic Ref. No.	Part No.	Description
Q608,622	0B06069A	Transistor 2SB564	CN13,17	0B08645A	9P-T Post
Q610	0B06316A	Transistor 2SD882	CN14	0B08643A	7P-T Post
Q611	0B06303A	Transistor 2SB772	CN15	0B08642A	6P-T Post
ZD601,602	0B06231A	Zener Diode 11V RD11EB2	CN16	0B08655A	11P-T Post
D603-610	0B01909A	Silicon Diode 1S1555 (8 pcs.)	CN18	0B08653A	3P-T Post
X601	0B08908A	Crystal 400KHz KBR400BT		0B08964A	Transistor Mica TO-126 (2 pcs.)
VR601,610	0B07257A	Semi-fixed Volume 100K		0E00507A	Nut Hex. M3 (2 pcs.)
VR602	0B07256A	Semi-fixed Volume 10K		0E00624A	Screw M3x10 Philips Pan Head (2A) (2 pcs.)
VR603	0B07329A	Semi-fixed Volume 2K			
R601,611	0B05509A	Carbon Resistor 33K ERD-25T J		0J04485A	Heat Sink B (1 pce.)
644,645				0M04222A	Label CN-15 (1 pce.)
646,650				0M04223A	Label CN-16 (1 pce.)
670,684				0M04224A	Label CN-17 (1 pce.)
R602-606	0B05627A	Carbon Resistor 330K ERD-25T J (10 pcs.)		0M04230A	Label CN-13 (1 pce.)
609,617				0M04231A	Label CN-14 (1 pce.)
668,693					
697					
R607,610	0B01889A	Carbon Resistor 100K ERD-25T J (15 pcs.)			
613,618					
620-627			F401,402		
629,643					
660			F401,402	0B08962A	Logic & Power P.C.B.
R608,691	0B06784A	Carbon Resistor 560K ERD-25T J	F401,402	0B08961A	Fuse 2.5A 250V (U.S.A., Canada & Others) (Japan)
R612	0B05692A	Carbon Resistor 68K ERD-25T J		0B08347U	Fuse T1A 250V (UK, Australia & 220V Class 2)
R614,615	0B01888A	Carbon Resistor 10K ERD-25T J	F403	0B08374A	Fuse 1A 250V (U.S.A., Canada & Others)
642,648			F403	0B08686A	Fuse 1A 250V (Japan)
652,698			F403	0B08960A	Fuse T500mA 250V (UK, Australia & 220V Class 2)
699				0E00857A	BT Screw M3x6 Philips Binding Head (2 pcs.)
R619,662	0B05622A	Carbon Resistor 2.2K ERD-25T J		0B08349A	Fuse Clip (UK, Australia & 220V Class 2) (6 pcs.)
R628	0B01682A	Carbon Resistor 6.8K ERD-25T J		0M04096C	Fuse Label T500mA (1 pce.) (UK, Australia & 220V Class 2)
R631	0B05776A	Carbon Resistor 1M ERD-25T J		0M03782A	Fuse Label 1A 250V (1 pce.) (U.S.A., Canada, Others & Japan)
R632,659	0B05671A	Carbon Resistor 2.2M ERD-25T J		0M04191A	Fuse Label T1A 250V (2 pcs.) (UK, Australia & 220V Class 2)
701				0B06255A	Transistor 2SD880 (Y)
R633	0B09075A	Carbon Resistor 30K ERD-25T J	Q401,410	0B06256A	Transistor 2SB834 (Y, GR)
R634	0B05560A	Carbon Resistor 18K ERD-25T J	Q404	0B08601A	Transistor Mica TO-220 (3 pcs.)
R635	0B09750A	Carbon Resistor 43K ERD-25T J		0B08602A	Transistor Bushing TO-220 (3 pcs.)
R636	0B05641A	Carbon Resistor 47K ERD-25T J		0E00037A	Earth Lug B-5 (1 pce.)
R637	0B09263A	Carbon Resistor 12K ERD-25T J		0E00172A	Washer 3mm Toothed Lock (1 pce.)
R638	0B05621A	Carbon Resistor 120K ERD-25T J		0E00507A	Nut Hex. M3 (3 pcs.)
R639,685	0B05668A	Carbon Resistor 82K ERD-25T J		0E00608A	Screw M3x10 Philips Pan Head (3A) (3 pcs.)
R641	0B09217A	Fail Safe Type Resistor 5.6 RDF-25S J		0E00857A	BT Screw M3x6 Philips Binding Head (1 pce.)
R647,700	0B05615A	Carbon Resistor 22K ERD-25T J		0J04484B	Heat Sink (1 pce.)
R649	0B09751A	Metal Film Resistor 76.8K SN14K2E F			
R651	0B05640A	Carbon Resistor 180K ERD-25T J			
R657,658	0B09269A	Metal Film Resistor 100K SN14K2E F			
R661	0B09472A	Metal Film Resistor 220K SN14K2E F			
R664	0B09300A	Metal Film Resistor 150K SN14K2E F			
R665,666	0B09756A	Metal Film Resistor 330K SN14K2E F			
R667	0B09451A	Metal Film Resistor 47K SN14K2E F			
R669	0B09216A	Fail Safe Type Resistor 10 RDF-25S J			
R680,681	0B09215A	Fail Safe Type Resistor 100 RDF-25S J			
R682,683	0B09321A	Fail Safe Type Resistor 4.7 RDF-25S J			
R692	0B09380A	Carbon Resistor 1.5M ERD-25T J			
R694,695	0B09755A	Carbon Resistor 750K ERD-25T J			
696					
C601	0B01402A	Electrolytic Capacitor 4.7μ 25V			
C602	0B05652A	Mylar Capacitor 4700P 50V J			
C603	0B01802A	Mylar Capacitor 2200P 50V J			
C605,606	0B01405A	Electrolytic Capacitor 1μ 50V			
C607	0B09277A	Ceramic Capacitor 10P 50V J			
C608,609	0B01502A	Electrolytic Capacitor 330μ 16V			
610					
C611,612	0B09283A	Ceramic Capacitor 220P 50V K			

Schematic Ref. No.	Part No.	Description	Schematic Ref. No.	Part No.	Description
	BA04622A	Logic & Power P.C.B. Ass'y (U.S.A., Canada & Others)	Q608,622	OB06069A	Transistor 2SB564
	BA04621A	Logic & Power P.C.B. Ass'y (Japan)	Q610	OB06316A	Transistor 2SD882
	BA04623A	Logic & Power P.C.B. Ass'y (UK, Australia & 220V Class 2) Serial Nos.: A12401001 - A12402300	Q611	OB06303A	Transistor 2SB772
	- DC Supply -		ZD601,602	OB06231A	Zener Diode 11V RD11EB2
IC401	OB06124B	IC RC4558D	D603-610	OB01909A	Silicon Diode 1S1555 (8 pcs.)
Q402,403	OB06100A	Transistor 2SC945 (A)	X601	OB08908A	Crystal 400KHz KBR400BT
407,411			VR601,610	OB07257A	Semi-fixed Volume 100K
412,413			VR602	OB07256A	Semi-fixed Volume 10K
Q405,406	OB06013A	Transistor 2SA733	VR603	OB07329A	Semi-fixed Volume 2K
409			R601,611	OB05509A	Carbon Resistor 33K ERD-25T J
Q408	OB06322A	Transistor 2SC2002	644,645		
Q414	OB01426A	Transistor 2SA562	646,650		
ZD401	OB06058A	Zener Diode 5.1V YZ051	670,684		
ZD402	OB06314A	Zener Diode 6.2V YZ062	R602-606	OB05627A	Carbon Resistor 330K ERD-25T J (10 pcs.)
D401,402	OB06109A	Silicon Diode GP08B	609,617		
D404	OB01909A	Silicon Diode 1S1555	668,693		
D405,406	OB06282A	Diode Bridge DBA10	697		
R401,411	OB01857A	Carbon Resistor 1K ERD-25T J	R607,610	OB01889A	Carbon Resistor 100K ERD-25T J (15 pcs.)
424			613,618		
R402,412	OB01679A	Carbon Resistor 100 ERD-25T J	620-627		
R403,413	OB01846A	Carbon Resistor 4.7K ERD-25T J	629,643		
R404,414	OB01888A	Carbon Resistor 10K ERD-25T J	660		
R405,415	OB05627A	Carbon Resistor 330K ERD-25T J	R608,691	OB05784A	Carbon Resistor 560K ERD-25T J
421			R612	OB05692A	Carbon Resistor 68K ERD-25T J
R406	OB09528A	Metal Film Resistor 13.7K SN14K2E F	R614,615	OB01888A	Carbon Resistor 10K ERD-25T J
R407	OB09203A	Metal Film Resistor 10K SN14K2E F	642,648		
R408,416	OB01887A	Carbon Resistor 5.6K ERD-25T J	652,698		
420,431			699		
R409	OB05794A	Carbon Resistor 680 ERD-25T J	R619,662	OB05622A	Carbon Resistor 2.2K ERD-25T J
R410,417	OB09128A	Metal Film Resistor 11K SN14K2E F	R628	OB01682A	Carbon Resistor 6.8K ERD-25T J
R418,423	OB01889A	Carbon Resistor 100K ERD-25T J	R631	OB05776A	Carbon Resistor 1M ERD-25T J
425,426			R632,659	OB05671A	Carbon Resistor 2.2M ERD-25T J
R419	OB05560A	Carbon Resistor 18K ERD-25T J	701		
R427	OB05509A	Carbon Resistor 33K ERD-25T J	R633	OB09075A	Carbon Resistor 30K ERD-25T J
R428	OB05675A	Carbon Resistor 3.9K ERD-25T J	R634	OB05560A	Carbon Resistor 18K ERD-25T J
R429	OB05626A	Carbon Resistor 150K ERD-25T J	R635	OB09750A	Carbon Resistor 43K ERD-25T J
R430	OB05622A	Carbon Resistor 2.2K ERD-25T J	R636	OB05641A	Carbon Resistor 47K ERD-25T J
C401,402	OB09374A	Electrolytic Capacitor 6800μ 25V	R637	OB09263A	Carbon Resistor 12K ERD-25T J
C403,406	OB01272A	Electrolytic Capacitor 100μ 25V	R638	OB05621A	Carbon Resistor 120K ERD-25T J
C404	OB09377A	Electrolytic Capacitor 4700μ 16V	R639,685	OB05668A	Carbon Resistor 82K ERD-25T J
C405	OB05654A	Electrolytic Capacitor 2200μ 25V	R641	OB09217A	Fail Safe Type Resistor 5.6 RDF-25S J
C407,409	OB01397A	Electrolytic Capacitor 1000μ 16V	R647,700	OB05615A	Carbon Resistor 22K ERD-25T J
C408	OB09251A	Electrolytic Capacitor 33μ 25V	R649	OB09751A	Metal Film Resistor 76.8K SN14K2E F
C410	OB01406A	Electrolytic Capacitor 2200μ 16V	R651	OB05640A	Carbon Resistor 180K ERD-25T J
C411	OB05682A	Mylar Capacitor 0.068μ 50V J	R657,658	OB09269A	Metal Film Resistor 100K SN14K2E F
	- Logic -		R661	OB09472A	Metal Film Resistor 220K SN14K2E F
IC601	OB06324A	IC LM6402A-052	R664	OB09300A	Metal Film Resistor 150K SN14K2E F
IC602	OB06317A	IC μPD4030BC	R665,666	OB09756A	Metal Film Resistor 330K SN14K2E F
IC603	OB06124B	IC RC4558D	R667	OB09451A	Metal Film Resistor 47K SN14K2E F
Q601,602	OB06100A	Transistor 2SC945 (A)	R669	OB09216A	Fail Safe Type Resistor 10 RDF-25S J
609,613			R680,681	OB09215A	Fail Safe Type Resistor 100 RDF-25S J
621,625			R682,683	OB09321A	Fail Safe Type Resistor 4.7 RDF-25S J
Q603,604	OB06013A	Transistor 2SA733	R692	OB09380A	Carbon Resistor 1.5M ERD-25T J
605,606			R694,695	OB09755A	Carbon Resistor 750K ERD-25T J
623,626			696		
Q607,620	OB06056A	Transistor 2SD471	C601	OB01402A	Electrolytic Capacitor 4.7μ 25V
			C602	OB05652A	Mylar Capacitor 4700P 50V J
			C603	OB01802A	Mylar Capacitor 2200P 50V J
			C605,606	OB01405A	Electrolytic Capacitor 1μ 50V
			C607	OB09277A	Ceramic Capacitor 10P 50V J
			C608,609	OB01502A	Electrolytic Capacitor 330μ 16V
			610		
			C611,612	OB09283A	Ceramic Capacitor 220P 50V K

Schematic Ref. No.	Part No.	Description
CN13,17	0B08645A	9P-T Post
CN14	0B08643A	7P-T Post
CN15	0B08642A	6P-T Post
CN16	0B08655A	11P-T Post
CN18	0B08653A	3P-T Post
	0B08964A	Transistor Mica TO-126 (2 pcs.)
	0E00507A	Nut Hex. M3 (2 pcs.)
	0E00624A	Screw M3x10 Philips Pan Head (2A) (2 pcs.)
	0J04485A	Heat Sink B (1 pce.)
	0M04222A	Label CN-15 (1 pce.)
	0M04223A	Label CN-16 (1 pce.)
	0M04224A	Label CN-17 (1 pce.)
	0M04230A	Label CN-13 (1 pce.)
	0M04231A	Label CN-14 (1 pce.)
- Miscellaneous -		
F401,402	0B02501A	Logic & Power P.C.B.
F401,402	0B08962A	Fuse 2.5A 250V (U.S.A., Canada & Others)
F401,402	0B08961A	Fuse 2.5A 250V (Japan)
F401,402	0B08347U	Fuse T1A 250V (UK, Australia & 220V Class 2)
F403	0B08374A	Fuse 1A 250V (U.S.A., Canada & Others)
F403	0B08686A	Fuse 1A 250V (Japan)
F403	0B08960A	Fuse T500mA 250V (UK, Australia & 220V Class 2)
	0E00857A	BT Screw M3x6 Philips Binding Head (2 pcs.)
	0B08349A	Fuse Clip (UK, Australia & 220V Class 2) (6 pcs.)
	0M04096C	Fuse Label T500mA (UK, Australia & 220V Class 2) (1 pce.)
	0M03782A	Fuse Label 1A 250V (U.S.A., Canada, Others & Japan) (1 pce.)
	0M04191A	Fuse Label T1A 250V (UK, Australia & 220V Class 2) (2 pcs.)
Q401,410	0B06255A	Transistor 2SD880 (Y)
Q404	0B06256A	Transistor 2SB834 (Y, GR)
	0B08601A	Transistor Mica TO-220 (3 pcs.)
	0B08602A	Transistor Bushing TO-220 (3 pcs.)
	0E00037A	Earth Lug B-5 (1 pce.)
	0E00172A	Washer 3mm Toothed Lock (1 pce.)
	0E00507A	Nut Hex. M3 (3 pcs.)
	0E00608A	Screw M3x10 Philips Pan Head (3A) (3 pcs.)
	0E00857A	BT Screw M3x6 Philips Binding Head (1 pce.)
	0J04484B	Heat Sink (1 pce.)

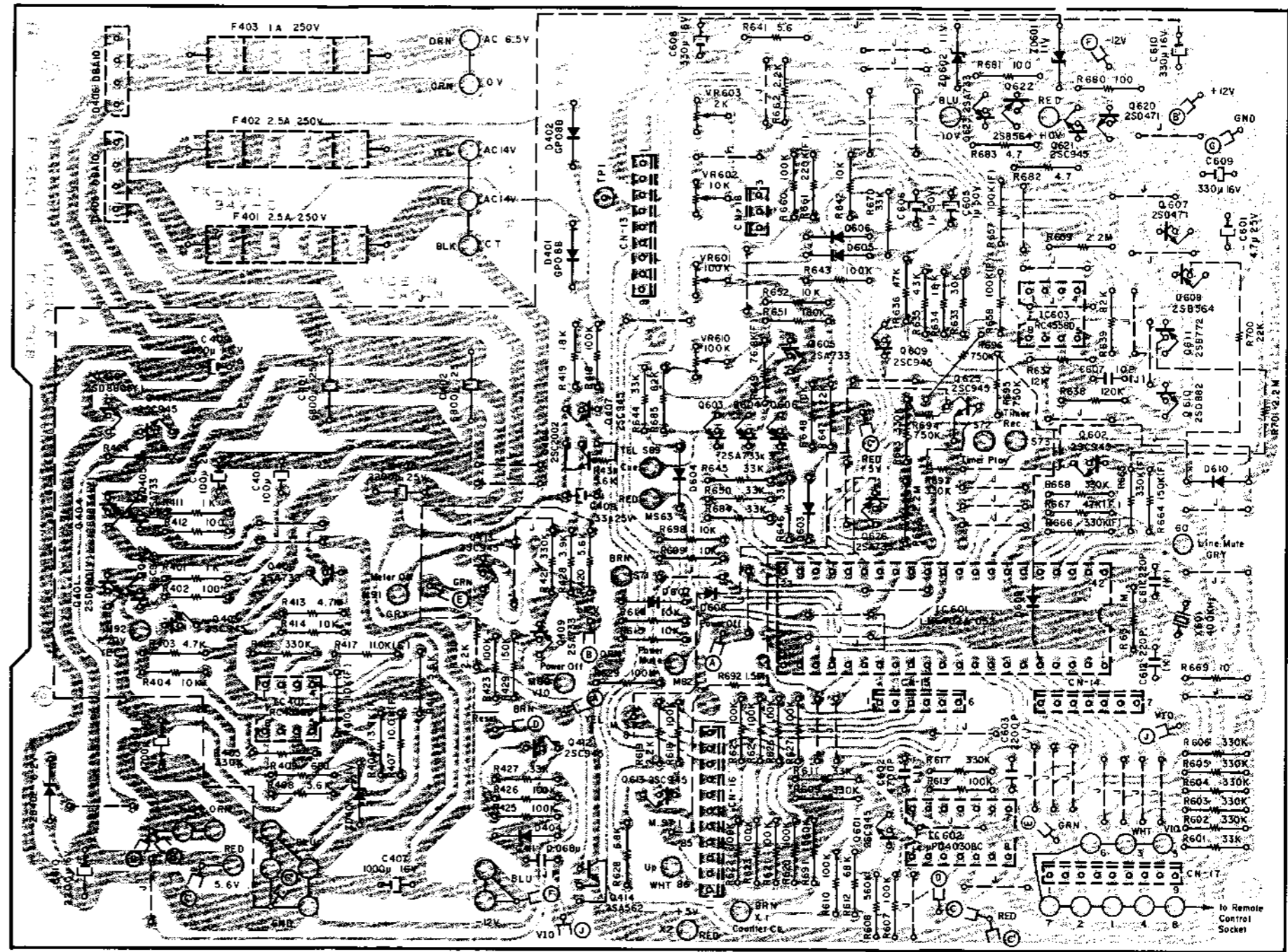

Fig. 7.13.2 Serial Nos.: A12401001 - A12402300

Note: Diode is 1S553, 1S953, or 1S1555 unless otherwise specified.



7.14. Main P.C.B. Ass'y

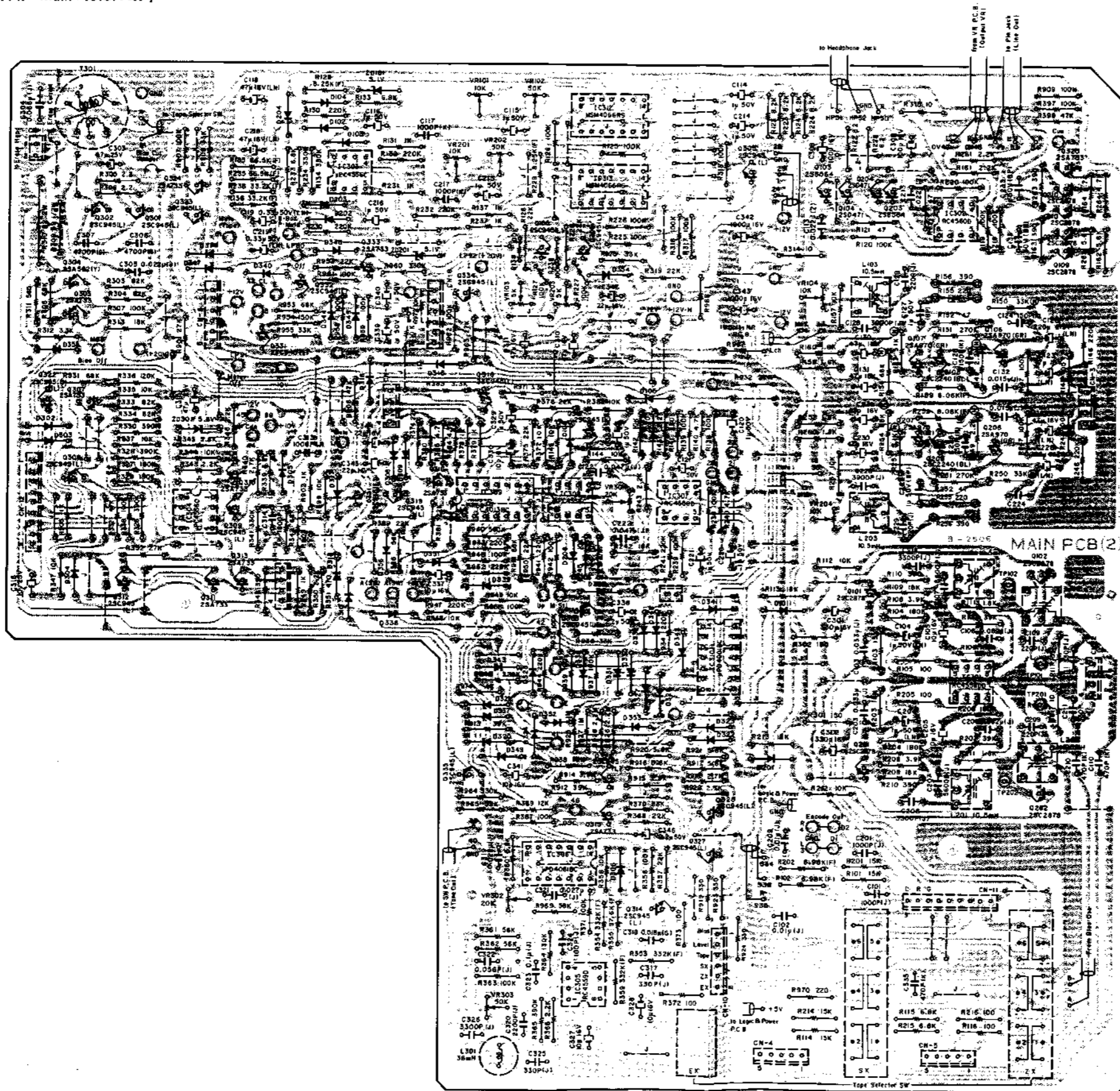

Fig. 7.14.1 Serial No.: A12404901 - Note: Diode is 1SS53, 1S953, or 1S1555 unless otherwise specified.

Schematic Ref. No.	Part No.	Description	
	BA04535A	Main P.C.B. Ass'y Serial No.: A12404901 -	
		- PB Eq. Amp. -	
Q106,107 206,207	0B06180A	Transistor	2SA970 (GR)
Q108,208	0B06142A	Transistor	2SC2240 (BL)
L103,203	0B00068A	Trap Coil	10.5mH
VR104,204	0B07233A	Semi-fixed Volume	10K
R146,246	0B05625A	Carbon Resistor	220K ERD-25T J
R147,247	0B01889A	Carbon Resistor	100K ERD-25T J
R148,248	0B01679A	Carbon Resistor	100 ERD-25T J
R149,249	0B09309A	Carbon Resistor	2.2K ERD-25TS J (Noiseless)
R150,250	0B09310A	Carbon Resistor	33K ERD-25TS J (Noiseless)
R151,251	0B05620A	Carbon Resistor	270K ERD-25T J
R152,252	0B01706A	Carbon Resistor	47 ERD-25T J
R153,253	0B09388A	Carbon Resistor	5.1K ERD-25TS J (Noiseless)
R154,254	0B09311A	Carbon Resistor	68K ERD-25TS J (Noiseless)
R155,255	0B01933A	Carbon Resistor	220 ERD-25T J
R156,256	0B05691A	Carbon Resistor	390 ERD-25T J
R157,257	0B01888A	Carbon Resistor	10K ERD-25T J
R158,160 258,260	0B06614A	Carbon Resistor	1.8K ERD-25T J
R159,259	0B09431A	Metal Film Resistor	8.06K SN14K2E F
C123,223	0B09218A	Electrolytic Capacitor	47μ 16V (LN)
C124,126 224,226	0B09281A	Ceramic Capacitor	150P 50V K
C125,225	0B09151A	Electrolytic Capacitor	220μ 6.3V (LN)
C127,227	0B09187A	Electrolytic Capacitor	1μ 50V (BP)
C128,228	0B01804A	Mylar Capacitor	3900P 50V J
C129,229	0B09247A	Mica Capacitor	220P 50V J
C130,131 230,231	0B01403A	Electrolytic Capacitor	47μ 16V
C132,232	0B05557A	Mylar Capacitor	0.015μ 50V J
		- Rec. Amp. -	
IC301	0B06146A	IC	RC4558DD
Q101,102 201,202	0B06299A	Transistor	2SC2878
D101,201	0B06181A	Silicon Diode	1SS53
L101,102 201,202	0B00068A	Trap Coil	10.5mH
R101,103 201,203	0B01683A	Carbon Resistor	15K ERD-25T J
R102,202	0B09604A	Metal Film Resistor	6.98K SN14K2E F
R104,106 204,206	0B05640A	Carbon Resistor	180K ERD-25T J
R105,116 205,216	0B01679A	Carbon Resistor	100 ERD-25T J
R107,207	0B01854A	Carbon Resistor	39K ERD-25T J
R108,208	0B05675A	Carbon Resistor	3.9K ERD-25T J
R109,113 209,213	0B05560A	Carbon Resistor	18K ERD-25T J
R110,210	0B05691A	Carbon Resistor	390 ERD-25T J
R111,211	0B05614A	Carbon Resistor	1.8K ERD-25T J
R112,212	0B01888A	Carbon Resistor	10K ERD-25T J
R114,214	0B01683A	Carbon Resistor	15K ERD-25T J

Schematic Ref. No.	Part No.	Description	Schematic Ref. No.	Part No.	Description	Schematic Ref. No.	Part No.	Description	Schematic Ref. No.	Part No.	Description	Schematic Ref. No.	Part No.	Description	Schematic Ref. No.	Pa
R115,215	OB01682A	Carbon Resistor 6.8K ERD-25T J	R128,228	OB05615A	Carbon Resistor 22K ERD-25T J	C320	OB01802A	Mylar Capacitor 2200P 50V J	C120,121	OB01405A	Electrolytic Capacitor 1µ 50V	R397,903				080
R117,217	OB05936A	Carbon Resistor 10 ERD-25T J	319			C321	OB09045A	Mylar Capacitor 0.027µ 50V J	220,221			907,909				080
R301,302	OB09213A	Fail Safe Type Resistor 150 RDF-25S J	R129,229	OB09432A	Metal Film Resistor 8.25K SN14K2E F	C322	OB05813A	Mylar Capacitor 0.056µ 50V J	329,332			962				
R970	OB01933A	Carbon Resistor 220 ERD-25T J	R130,132	OB05625A	Carbon Resistor 220K ERD-25T J	C323	OB01780A	Mylar Capacitor 0.1µ 50V J	C122,222	OB05796A	Mylar Capacitor 0.047µ 50V J	R398,906	OB0			080
C101,201	OB05550A	Mylar Capacitor 1000P 50V J	230,232			C324	OB09302A	Mica Capacitor 100P 100V J	C330,337	OB01412A	Electrolytic Capacitor 10µ 16V	R399,972	OB0			080
C102,202	OB05681A	Mylar Capacitor 0.01µ 50V J	R131,137	OB01857A	Carbon Resistor 1K ERD-25T J	C326	OB01914A	Mylar Capacitor 3300P 50V J	341			973				
C103,203	OB05683A	Mylar Capacitor 0.033µ 50V J	231,237			C327,328	OB01412A	Electrolytic Capacitor 10µ 16V	C338,346	OB09372A	Electrolytic Capacitor 2.2µ 50V	R901,932	OB0			080
C104,204	OB09223A	Electrolytic Capacitor 1µ 50V (LN)	R133,233	OB01682A	Carbon Resistor 6.8K ERD-25T J				C344,345	OB01862A	Electrolytic Capacitor 22µ 16V	R902	OB0			080
C105,205	OB01412A	Electrolytic Capacitor 10µ 16V	R134,234	OB05627A	Carbon Resistor 330K ERD-25T J							R908	OB0			080
C106,206	OB05685A	Mylar Capacitor 0.082µ 50V J	R135,235	OB09510A	Metal Film Resistor 66.5K SN14K2E F							R912,913	OB0			080
C107,207	OB05659A	Mylar Capacitor 5600P 50V J	R136,236	OB09446A	Metal Film Resistor 33.2K SN14K2E F							R914,915	OB0			080
C108,208	OB01914A	Mylar Capacitor 3300P 50V J	R975	OB05509A	Carbon Resistor 33K ERD-25T J	IC307	OB06124B	IC RC4558D	IC304	OB06216A	IC µPC4556C	R918,922	OB0			080
C109,209	OB09247A	Mica Capacitor 220P 50V J	C114,115	OB01405A	Electrolytic Capacitor 1µ 50V	IC308	OB06216A	IC µPC4556C	Q307,310	OB06013A	Transistor 2SA733	R919,923	OB0			080
C110,210	OB09286A	Ceramic Capacitor 470P 50V K	118,214			IC309	OB06213A	IC TC40138P	311,313			924				
C111,211	OB09322A	PP Capacitor 330P 100V J	215,216			Q316,333	OB06013A	Transistor 2SA733	Q308,309	OB01872A	Transistor 2SC945 (L)	R925,927	OB0			080
C301,302	OB01502A	Electrolytic Capacitor 330µ 16V	C117,217	OB09288A	Ceramic Capacitor 1000P 50V K	Q317,318	OB01872A	Transistor 2SC945 (L)	312			R926,928	OB0			080
		- Bias Osc. -	C118,218	OB09218A	Electrolytic Capacitor 47µ 16V (LN)	319,330			ZD301	OB06290A	Zener Diode 5.6V RD5.6EB2	R967,968	OB0			080
Q301,302	OB01872A	Transistor 2SC945 (L)	C119,219	OB09385A	Electrolytic Capacitor 0.33µ 50V (LN)	331,332			D302,303	OB06181A	Silicon Diode 1SS53	C133,233	OB0			080
Q303	OB06013A	Transistor 2SA733	C310,311	OB01403A	Electrolytic Capacitor 47µ 16V	334,335			304,305			C335	OB0			080
Q304	OB06202A	Transistor 2SA562 (Y)	C347	OB01862A	Electrolytic Capacitor 22µ 16V	D105,106	OB06181A	Silicon Diode 1SS53 (26 pcs.)	R326,328	OB05676A	Carbon Resistor 390K ERD-25T J	C339,340	OB0			080
D355	OB06181A	Silicon Diode 1SS53				308,309			330			C342,343	OB0			080
T301	OB06613A	Osc. Coil			- Headphone Amp. -	310			R327,329	OB05640A	Carbon Resistor 180K ERD-25T J	CN1,9	OB0			080
R303,304	OB05668A	Carbon Resistor 82K ERD-25T J	IC302	OB06217A	IC RC4560D	335-349			R331,342	OB05692A	Carbon Resistor 68K ERD-25T J	CN2,3,7	OB0			080
R305,306	OB09212A	Fail Safe Type Resistor 2.2 RDF-25S J	Q103,203	OB06069A	Transistor 2SB564	351,352			R332	OB05641A	Carbon Resistor 47K ERD-25T J	19	OB0			080
R307	OB01889A	Carbon Resistor 100K ERD-25T J	Q104,204	OB06066A	Transistor 2SD471	353,356			R333,334	OB05668A	Carbon Resistor 82K ERD-25T J	CN4,5	OB0			080
R308	OB05692A	Carbon Resistor 88K ERD-25T J	R119,120	OB01889A	Carbon Resistor 100K ERD-25T	VR304	OB07270A	Semi-fixed Volume 20K	R335,337	OB01888A	Carbon Resistor 10K ERD-25T J	CN6,8,10	OB0			080
R309	OB09296A	Fail Safe Type Resistor 39 RSF-1/2B J	R121,221	OB01706A	Carbon Resistor 47 ERD-25T J	R138,139	OB01889A	Carbon Resistor 100K ERD-25T J	344,347			CN11,12	OB0			080
R310	OB09295A	Fail Safe Type Resistor 82 RSF-2B J	R122,222	OB09331A	Fail Safe Type Resistor 8.2 RDF-25S J	238,239			R336	OB05621A	Carbon Resistor 120K ERD-25T J		OB0			080
R311	OB05575A	Carbon Resistor 560 ERD-25T J	R122,222	OB09331A	Fail Safe Type Resistor 8.2 RDF-25S J	935,937			R338	OB01889A	Carbon Resistor 100K ERD-25T J		OB0			080
R312	OB01681A	Carbon Resistor 3.3K ERD-25T J	R314,315	OB09216A	Fail Safe Type Resistor 10 RDF-25S J	939,942			R339,345	OB01887A	Carbon Resistor 5.6K ERD-25T J		OB0			080
R313	OB05660A	Carbon Resistor 18K ERD-25T J	C113,213	OB09291A	Ceramic Capacitor 0.022µ 50V Z	946,956			R340	OB05629A	Carbon Resistor 2.7K ERD-25T J		OB0			080
R905	OB01857A	Carbon Resistor 1K ERD-25T J	C308,309	OB01400A	Electrolytic Capacitor 100µ 16V	958,959			R341	OB05627A	Carbon Resistor 330K ERD-25T J		OB0			080
C303	OB01402A	Electrolytic Capacitor 4.7µ 25V			- Tone Osc. -	961			R343,346	OB05622A	Carbon Resistor 2.2K ERD-25T J		OB0			080
C304	OB09254A	PP Capacitor 0.068µ 100V J				R140,240	OB01846A	Carbon Resistor 4.7K ERD-25T J	350				OB0			080
C305	OB09405A	PP Capacitor 0.022µ 100V J	IC305	OB06127A	IC RC4559D	384,385			R348	OB05691A	Carbon Resistor 390 ERD-25T J		OB0			080
C306,307	OB09191A	PP Capacitor 4700P 100V G	IC306	OB06219A	IC µPD4081BC	R141,241	OB05625A	Carbon Resistor 220K ERD-25T J	R349	OB01857A	Carbon Resistor 1K ERD-25T J		OB0			080
	OJ04450A	Osc. Coil Cap (1 pcs.)	Q314	OB01872A	Transistor 2SC945 (L)	934,941			R351	OB05576A	Carbon Resistor 470 ERD-25T J		OB0			080
		- Meter Amp. -	Q315	OB06013A	Transistor 2SA733	943,944			R352	OB05743A	Carbon Resistor 27K ERD-25T J		OB0			080
IC303	OB06216A	IC µPC4556C	D306	OB06181A	Silicon Diode 1SS53	945,947			C313	OB05550A	Mylar Capacitor 1000P 50V J		OB0			080
IC312,313	OB06280A	IC MSM4066RS	L301	OB03919B	Inductor 36mH	952			C314	OB01913A	Mylar Capacitor 1800P 50V J		OB0			080
Q105,205	OB01872A	Transistor 2SC945 (L)	VR302	OB07270A	Semi-fixed Volume 20K	R142,144	OB01888A	Carbon Resistor 10K ERD-25T J	C315	OB01409A	Electrolytic Capacitor 47µ 25V		OB0			080
305			VR303	OB07269A	Semi-fixed Volume 50K	145,242			C316	OB01674A	Electrolytic Capacitor 10µ 25V		OB0			080
ZD101,201	OB06058A	Zener Diode 5.1V YZ051	R353,354	OB09315A	Metal Film Resistor 332K SN14K2E F	244,245							OB0			080
D102,103	OB06181A	Silicon Diode 1SS53	359			377,382							OB0			080
104,202			R355	OB09583A	Metal Film Resistor 97.6K SN14K2E F	938,948							OB0			080
203,204			R356,363	OB01889A	Carbon Resistor 100K ERD-25T J	949							OB0			080
354			367,371			R143,243	OB05622A	Carbon Resistor 2.2K ERD-25T J	IC310	OB02506D	Main P.C.B.		OB0			080
VR101,201	OB07256A	Semi-fixed Volume 10K	R357,368	OB05615A	Carbon Resistor 22K ERD-25T J	R374,375	OB05615A	Carbon Resistor 22K ERD-25T J	Q109,110	OB06143A	IC µPD4001BC		OB0			080
VR102,202	OB07269A	Semi-fixed Volume 50K	R358	OB01888A	Carbon Resistor 10K ERD-25T J	376,381			209,210	OB06299A	Transistor 2SC2878		OB0			080
VR103,203	OB07341A	Semi-fixed Volume 5K	R359	OB01682A	Carbon Resistor 6.8K ERD-25T J	389,950			Q320,324	OB06013A	Transistor 2SA733		OB0			080
R123,124	OB01856A	Carbon Resistor 8.2K ERD-25T J	R360	OB05508A	Carbon Resistor 56K ERD-25T J	957			Q321,322	OB01872A	Transistor 2SC945 (L)		OB0			080
223,224			R361,362			957			323,326				OB0			080
R125,126	OB01889A	Carbon Resistor 100K ERD-25T J	969			R378,379	OB01857A	Carbon Resistor 1K ERD-25T J	327,328				OB0			080
127,138			R364	OB09527A	Carbon Resistor 130K ERD-25T J	380,974			327,328				OB0			080
225,226			R365	OB05676A	Carbon Resistor 390K ERD-25T J	R383,971	OB01681A	Carbon Resistor 3.3K ERD-25T J	D314-318	OB06181A	Silicon Diode 1SS53 (16 pcs.)		OB0			080
227,238			R366	OB05622A	Carbon Resistor 2.2K ERD-25T J	R386	OB05508A	Carbon Resistor 56K ERD-25T J	320-324				OB0			080
316,317			R369	OB09346A	Carbon Resistor 12K ERD-25T J	R936,965	OB05509A	Carbon Resistor 33K ERD-25T J	327-332				OB0			080
318			R370	OB05509A	Carbon Resistor 33K ERD-25T J	965			R161,261	OB05622A	Carbon Resistor 2.2K ERD-25T J		OB0			080
			R372,373	OB09215A	Fail Safe Type Resistor 100 RDF-25S J	R940	OB05784A	Carbon Resistor 560K ERD-25T J	R162,262	OB01887A	Carbon Resistor 5.6K ERD-25T J		OB0			080
			C317,325	OB09545A	Mica Capacitor 330P 50V J	R951,953	OB09311A	Carbon Resistor 68K ERD-25T J	916,917				OB0			080
			C318	OB09538A	PP Capacitor 0.018µ 100V G	R954	OB05626A	Carbon Resistor 150K ERD-25T J	920,921				OB0			080
			C319	OB05682A	Mylar Capacitor 0.022µ 50V J	R960,964	OB05627A	Carbon Resistor 330K ERD-25T J	R163,263	OB05691A	Carbon Resistor 390 ERD-25T J		OB0			080
						R963	OB05743A	Carbon Resistor 27K ERD-25T J	R164,264	OB01846A	Carbon Resistor 4.7K ERD-25T J		OB0			080

Schematic Ref. No.	Part No.	Description	Schematic Ref. No.	Part No.	Description	Schematic Ref. No.	Part No.	Description	Schematic Ref. No.	Part No.	Description	Schematic Ref. No.	Part No.	Description	Schematic Ref. No.	Part No.	Description
Q106,107	0B06180A	Transistor 2SA970 (GR)	R115,215	0B01682A	Carbon Resistor 6.8K ERD-25T J	R128,228	0B05615A	Carbon Resistor 22K ERD-25T J	C320	0B01802A	Mylar Capacitor 2200P 50V J	C120,121	0B01405A	Electr			
Q206,207			R117,217	0B05936A	Carbon Resistor 10 ERD-25T J	319			C321	0B09045A	Mylar Capacitor 0.027μ 50V J	220,221					
Q108,208	0B06142A	Transistor 2SC2240 (BL)	R301,302	0B09213A	Fail Safe Type Resistor 150 RDF-25S J	R129,229	0B09432A	Metal Film Resistor 8.25K SN14K2E F	C322	0B05813A	Mylar Capacitor 0.056μ 50V J	329,332	0B05796A	Mylar			
L103,203	0B00068A	Trap Coil 10.5mH	R970	0B01933A	Carbon Resistor 220 ERD-25T J	R130,132	0B05625A	Carbon Resistor 220K ERD-25T J	C323	0B01780A	Mylar Capacitor 0.1μ 50V J	C122,222	0B01412A	Electr			
VR104,204	0B07233A	Semi-fixed Volume 10K	C101,201	0B05550A	Mylar Capacitor 1000P 50V J	230,232			C324	0B09302A	Mica Capacitor 100P 100V J	C330,337					
R146,246	0B05625A	Carbon Resistor 220K ERD-25T J	C102,202	0B05681A	Mylar Capacitor 0.01μ 50V J	R131,137	0B01857A	Carbon Resistor 1K ERD-25T J	C326	0B01914A	Mylar Capacitor 3300P 50V J	341	0B09372A	Electr			
R147,247	0B01889A	Carbon Resistor 100K ERD-25T J	C103,203	0B05583A	Mylar Capacitor 0.033μ 50V J	231,237			C327,328	0B01412A	Electrolytic Capacitor 10μ 16V	C338,346	0B01862A	Electr			
R148,248	0B01679A	Carbon Resistor 100 ERD-25T J	C104,204	0B09223A	Electrolytic Capacitor 1μ 50V (LN)	R133,233	0B01682A	Carbon Resistor 6.8K ERD-25T J				C344,345					
R149,249	0B09309A	Carbon Resistor 2.2K ERD-25TS J (Noiseless)	C105,205	0B01412A	Electrolytic Capacitor 10μ 16V	R134,234	0B05627A	Carbon Resistor 330K ERD-25T J									
R150,250	0B09310A	Carbon Resistor 33K ERD-25TS J (Noiseless)	C106,206	0B05685A	Mylar Capacitor 0.082μ 50V J	R135,235	0B09510A	Metal Film Resistor 66.5K SN14K2E F	IC307	0B06124B	IC RC4558D						
R151,251	0B05620A	Carbon Resistor 270K ERD-25T J	C107,207	0B05659A	Mylar Capacitor 5600P 50V J	R136,236	0B09446A	Metal Film Resistor 33.2K SN14K2E F	IC308	0B06216A	IC μPC4556C	IC304	0B06216A	IC			
R152,252	0B01706A	Carbon Resistor 47 ERD-25T J	C108,208	0B01914A	Mylar Capacitor 3300P 50V J	R975	0B05509A	Carbon Resistor 33K ERD-25T J	IC309	0B06213A	IC TC4013BP	Q307,310	0B08013A	Transi:			
R153,253	0B09388A	Carbon Resistor 5.1K ERD-25TS J (Noiseless)	C109,209	0B09247A	Mica Capacitor 220P 50V J	C114,115	0B01405A	Electrolytic Capacitor 1μ 50V	Q316,333	0B06013A	Transistor 2SA733	311,313	0B01872A	Transi:			
R154,254	0B09311A	Carbon Resistor 68K ERD-25TS J (Noiseless)	C110,210	0B09286A	Ceramic Capacitor 470P 50V K	116,214			Q317,318	0B01872A	Transistor 2SC945 (L)	Q308,309					
R155,255	0B01933A	Carbon Resistor 220 ERD-25T J	C111,211	0B09322A	PP Capacitor 330P 100V J	215,216			319,330			312					
R156,256	0B05691A	Carbon Resistor 390 ERD-25T J	C301,302	0B01502A	Electrolytic Capacitor 330μ 16V	C117,217	0B09288A	Ceramic Capacitor 1000P 50V K	331,332			ZD301	0B06290A	Zener			
R157,257	0B01888A	Carbon Resistor 10K ERD-25T J	Q303			C118,218	0B09218A	Electrolytic Capacitor 47μ 16V (LN)	334,335			D302,303	0B06181A	Silicor			
R158,160	0B06614A	Carbon Resistor 1.8K ERD-25T J	Q304	0B01872A	Transistor 2SC945 (L)	C119,219	0B09385A	Electrolytic Capacitor 0.33μ 50V (LN)	D105,106	0B06181A	Silicon Diode 1SS53 (26 pcs.)	304,305					
R159,259	0B09431A	Metal Film Resistor 8.06K SN14K2E F	Q305	0B06013A	Transistor 2SA733	C310,311	0B01403A	Electrolytic Capacitor 47μ 16V	205,206			R326,328	0B05676A	Carbo			
C123,223	0B09218A	Electrolytic Capacitor 47μ 16V (LN)	D355	0B06181A	Silicon Diode 1SS53	C347	0B01862A	Electrolytic Capacitor 22μ 16V	308,309			310					
C124,126	0B09281A	Ceramic Capacitor 150P 50V K	T301	0B06613A	Osc. Coil				335-349			R327,329	0B05640A	Carbo			
C125,225	0B09161A	Electrolytic Capacitor 220μ 6.3V (LN)	R303,304	0B05668A	Carbon Resistor 82K ERD-25T J	IC302	0B06217A	IC RC4560D	351,352			R331,342	0B05692A	Carbo			
C127,227	0B09187A	Electrolytic Capacitor 1μ 50V (BP)	R305,306	0B09212A	Fail Safe Type Resistor 2.2 RDF-25S J	Q103,203	0B06069A	Transistor 2SB564	353,356			R332	0B05641A	Carbo			
C128,228	0B01804A	Mylar Capacitor 3900P 50V J	R307	0B01889A	Carbon Resistor 100K ERD-25T J	Q104,204	0B06066A	Transistor 2SD471	VR304	0B07270A	Semi-fixed Volume 20K	R333,334	0B05668A	Carbo			
C129,229	0B09247A	Mica Capacitor 220P 50V J	R308	0B05692A	Carbon Resistor 68K ERD-25T J	R119,120	0B01889A	Carbon Resistor 100K ERD-25T	R138,139	0B01889A	Carbon Resistor 100K ERD-25T J	R335,337	0B01888A	Carbo			
C130,131	0B01403A	Electrolytic Capacitor 47μ 16V	R309	0B09296A	Fail Safe Type Resistor 39 RSF-1/2B J	R121,221	0B01706A	Carbon Resistor 47 ERD-25T J	238,239			344,347					
230,231			R310	0B09295A	Fail Safe Type Resistor 82 RSF-2B J	R122,222	0B09331A	Fail Safe Type Resistor 8.2 RDF-25S J	935,937			R336	0B05621A	Carbo			
C132,232	0B05557A	Mylar Capacitor 0.015μ 50V J	R311	0B05575A	Carbon Resistor 560 ERD-25T J	R123,223	0B09216A	Fail Safe Type Resistor 10 RDF-25S J	939,942			R338	0B01889A	Carbo			
			R312	0B01681A	Carbon Resistor 3.3K ERD-25T J	R314,315	0B09291A	Ceramic Capacitor 0.022μ 50V Z	946,956			R339,345	0B01887A	Carbo			
			R313	0B05680A	Carbon Resistor 18K ERD-25T J	C113,213	0B01400A	Electrolytic Capacitor 100μ 16V	958,959			R340	0B05629A	Carbo			
			R905	0B01857A	Carbon Resistor 1K ERD-25T J	C308,309			961			R341	0B06627A	Carbo			
			C303	0B01402A	Electrolytic Capacitor 4.7μ 25V				R140,240	0B01846A	Carbon Resistor 4.7K ERD-25T J	R343,346	0B05622A	Carbo			
			C304	0B09254A	PP Capacitor 0.068μ 100V J				384,385			350					
			C305	0B09405A	PP Capacitor 0.022μ 100V J				R141,241	0B05625A	Carbon Resistor 220K ERD-25T J	R348	0B05691A	Carbo			
			C306,307	0B09191A	PP Capacitor 4700P 100V G				934,941			R349	0B01857A	Carbo			
				0J04450A	Osc. Coil Cap (1 pce.)				943,944			R351	0B05576A	Carbo			
									945,947			R352	0B05743A	Carbo			
									962			C313	0B05550A	Mylar			
									R142,144	0B01888A	Carbon Resistor 10K ERD-25T J	C314	0B01913A	Mylar			
									145,242			C315	0B01409A	Electr			
									244,245			C316	0B01674A	Electr			
									377,382								
									938,948								
									949								
									R143,243	0B05622A	Carbon Resistor 2.2K ERD-25T J	IC310	0B02506C	Main			
									R374,375	0B05615A	Carbon Resistor 22K ERD-25T J	Q109,110	0B06299A	Transi:			
									376,381			209,210					
									389,950			Q320,324	0B06013A	Transi:			
									967			Q321,322	0B01872A	Transi:			
									R378,379	0B01857A	Carbon Resistor 1K ERD-25T J	323,326					
									380,974			327,328					
									R383,971	0B01681A	Carbon Resistor 3.3K ERD-25T J	D314-318	0B06181A	Silicc			
									R386	0B05508A	Carbon Resistor 56K ERD-25T J	320-324					
									R936,955	0B05509A	Carbon Resistor 33K ERD-25T J	327-332					
									965			R161,261	0B05622A	Carbo			
									R940	0B05784A	Carbon Resistor 560K ERD-25T J	R162,262	0B01887A	Carbo			
									R951,953	0B09311A	Carbon Resistor 68K ERD-25T J	916,917					
									R954	0B05626A	Carbon Resistor 150K ERD-25T J	920,921					
									R960,964	0B05627A	Carbon Resistor 330K ERD-25T J	R163,263	0B05691A	Carbo			
									R963	0B05743A	Carbon Resistor 27K ERD-25T J	R164,264	0B01846A	Carbo			

Description	Schematic Ref. No.	Part No.	Description	Schematic Ref. No.	Part No.	Description	Schematic Ref. No.	Part No.	Description	Schematic Ref. No.	Part No.	Description
C.B. Assy Nos.: A12403401 - A12404900	R115,215 R117,217 R301,302 R970 C101,201 C102,202 C103,203 C104,204 C105,205 C106,206 C107,207 C108,208 C109,209 C110,210 C111,211 C301,302	OB01682A OB05936A OB09213A OB01933A OB05550A OB05681A OB05583A OB09223A OB01412A OB05685A OB05659A OB01914A OB09247A OB09286A OB09322A OB01502A	Carbon Resistor 6.8K ERD-25T J Carbon Resistor 10 ERD-25T J Fail Safe Type Resistor 150 RDF-25S J Carbon Resistor 220 ERD-25T J Mylar Capacitor 1000P 50V J Mylar Capacitor 0.01μ 50V J Mylar Capacitor 0.033μ 50V J Electrolytic Capacitor 1μ 50V (LN) Electrolytic Capacitor 10μ 16V Mylar Capacitor 0.082μ 50V J Mylar Capacitor 5600P 50V J Mylar Capacitor 3300P 50V J Mica Capacitor 220P 50V J Ceramic Capacitor 470P 50V K PP Capacitor 330P 100V J Electrolytic Capacitor 330μ 16V	R128,228 319 R129,229 R130,132 230,232 R131,137 231,237 R133,233 R134,234 R135,235 R136,236 R975 C114,115 116,214 215,216 C117,217 C118,218 C119,219 C310,311 C347	OB06615A OB09432A OB05625A OB01857A OB01682A OB05627A OB09510A OB09446A OB05509A OB01405A OB09288A OB09218A OB09385A OB01403A OB01862A OB06217A OB06069A OB06066A OB01889A OB01706A OB09331A OB09218A OB09291A OB01400A OB06127A OB06219A OB01872A OB06013A OB06181A OB03919B VR302 VR303 R353,354 359 R355 R356,363 367,371 R357,368 R358 R360 R361,362 969 R364 R365 R366 R369 R370 R372,373 R373,375 C318 C319	Carbon Resistor 22K ERD-25T J Metal Film Resistor 8.25K SN14K2E F Carbon Resistor 220K ERD-25T J Carbon Resistor 1K ERD-25T J Carbon Resistor 6.8K ERD-25T J Carbon Resistor 330K ERD-25T J Metal Film Resistor 66.5K SN14K2E F Metal Film Resistor 33.2K SN14K2E F Carbon Resistor 33K ERD-25T J Electrolytic Capacitor 1μ 50V Ceramic Capacitor 1000P 50V K Electrolytic Capacitor 47μ 16V (LN) Electrolytic Capacitor 0.33μ 50V (LN) Electrolytic Capacitor 47μ 16V Electrolytic Capacitor 22μ 16V IC RC4560D Transistor 2S8564 Transistor 2SD471 Carbon Resistor 100K ERD-25T Carbon Resistor 47 ERD-25T J Fail Safe Type Resistor 8.2 RDF-25S J Fail Safe Type Resistor 10 RDF-25S J Ceramic Capacitor 0.022μ 50V Z Electrolytic Capacitor 100μ 16V IC RC4559D IC μPD4081BC Transistor 2SC945 (L) Transistor 2SA733 Silicon Diode 1SS53 Inductor 36mH Semi-fixed Volume 20K Semi-fixed Volume 50K Metal Film Resistor 332K SN14K2E F Metal Film Resistor 97.6K SN14K2E F Carbon Resistor 100K ERD-25T J Carbon Resistor 22K ERD-25T J Carbon Resistor 10K ERD-25T J Carbon Resistor 6.8K ERD-25T J Carbon Resistor 56K ERD-25T J Carbon Resistor 130K ERD-25T J Carbon Resistor 390K ERD-25T J Carbon Resistor 2.2K ERD-25T J Carbon Resistor 12K ERD-25T J Carbon Resistor 33K ERD-25T J Fail Safe Type Resistor 100 RDF-25S J Mica Capacitor 330P 50V J PP Capacitor 0.018μ 100V G Mylar Capacitor 0.022μ 50V J	C320 C321 C322 C323 C324 C326 C327,328 IC307 IC308 IC309 Q316,333 Q317,318 319,330 331,332 334,335 D105,106 205,206 308,309 310 335-349 351,352 353,356 VR304 R138,139 238,239 935,937 939,942 946,956 958,959 961 R140,240 384,385 R141,241 934,941 943,944 945,947 952 R142,144 145,242 244,245 377,382 938,948 949 R143,243 R374,375 376,381 389,950 957 R378,379 380,974 R383,971 R386 R936,955 965 R940 R951,953 R954 R960,964 R963	OB01802A OB09045A OB05813A OB01780A OB09302A OB01914A OB01412A OB06124B OB06216A OB06213A OB06013A OB01872A OB06181A OB07270A OB01889A OB01846A OB05625A OB01888A OB06222A OB05615A OB01857A OB01681A OB05508A OB05509A OB09311A OB05626A OB05627A OB05743A	Mylar Capacitor 2200P 50V J Mylar Capacitor 0.027μ 50V J Mylar Capacitor 0.056μ 50V J Mylar Capacitor 0.1μ 50V J Mica Capacitor 100P 100V J Mylar Capacitor 3300P 50V J Electrolytic Capacitor 10μ 16V IC RC4558D IC μPC4556C IC TC4013BP Transistor 2SA733 Transistor 2SC945 (L) Silicon Diode 1SS53 (26 pcs.) Semi-fixed Volume 20K Carbon Resistor 100K ERD-25T J Carbon Resistor 4.7K ERD-25T J Carbon Resistor 220K ERD-25T J Carbon Resistor 10K ERD-25T J Carbon Resistor 2.2K ERD-25T J Carbon Resistor 22K ERD-25T J Carbon Resistor 1K ERD-25T J Carbon Resistor 3.3K ERD-25T J Carbon Resistor 56K ERD-25T J Carbon Resistor 68K ERD-25T J Carbon Resistor 150K ERD-25T J Carbon Resistor 330K ERD-25T J Carbon Resistor 27K ERD-25T J Carbon Resistor 1000P 50V J Mylar Capacitor 1800P 50V J Electrolytic Capacitor 47μ 25V Electrolytic Capacitor 10μ 25V Carbon Resistor 2.2K ERD-25T J Carbon Resistor 22K ERD-25T J	C120,121 220,221 329,332 C122,222 C330,337 341 C338,346 C344,345 IC304 Q307,310 311,313 Q308,309 312 ZD301 D302,303 304,305 R326,328 330 R327,329 R331,342 R332 R333,334 R335,337 344,347 R336 R338 R339,345 R340 R341 R343,346 350 R348 R349 R351 R352 C313 C314 C315 C316 IC310 Q109,110 209,210 Q320,324 Q321,322 323,326 327,328 D314-318 320-324 327-332 R161,261 R162,262 916,917 920,921 R163,263 R164,264	OB01405A OB05796A OB01412A OB09372A OB01862A OB06216A OB06013A OB01872A OB06290A OB06181A OB05676A OB06640A OB05692A OB05641A OB05668A OB01888A OB06621A OB01889A OB01887A OB05629A OB05627A OB05622A OB05691A OB01857A OB05676A OB05743A OB05550A OB01913A OB01409A OB01674A OB02506C OB06143A OB06299A OB06013A OB01872A OB06181A OB05622A OB01887A OB05691A OB01846A	Electrolytic Capacitor 1μ 50V Mylar Capacitor 0.047μ 50V J Electrolytic Capacitor 10μ 16V Electrolytic Capacitor 2.2μ 50V Electrolytic Capacitor 22μ 16V IC μPC4556C Transistor 2SA733 Transistor 2SC945 (L) Zener Diode 5.6V RD5.6EB2 Silicon Diode 1SS53 Carbon Resistor 390K ERD-25T J Carbon Resistor 180K ERD-25T J Carbon Resistor 68K ERD-25T J Carbon Resistor 47K ERD-25T J Carbon Resistor 82K ERD-25T J Carbon Resistor 10K ERD-25T J Carbon Resistor 120K ERD-25T J Carbon Resistor 100K ERD-25T J Carbon Resistor 5.6K ERD-25T J Carbon Resistor 2.7K ERD-25T J Carbon Resistor 330K ERD-25T J Carbon Resistor 2.2K ERD-25T J Carbon Resistor 390 ERD-25T J Carbon Resistor 1K ERD-25T J Carbon Resistor 470 ERD-25T J Carbon Resistor 27K ERD-25T J Mylar Capacitor 1000P 50V J Mylar Capacitor 1800P 50V J Electrolytic Capacitor 47μ 25V Electrolytic Capacitor 10μ 25V Main P.C.B. IC μPD4001BC Transistor 2SC2878 Transistor 2SA733 Transistor 2SC945 (L) Silicon Diode 1SS53 (16 pcs.) Carbon Resistor 2.2K ERD-25T J Carbon Resistor 5.6K ERD-25T J Carbon Resistor 390 ERD-25T J Carbon Resistor 4.7K ERD-25T J

Schematic Ref. No.	Part No.	Description	
R397,903 907,909 962	0B01889A	Carbon Resistor	100K ERD-25T J
R398,906	0B05641A	Carbon Resistor	47K ERD-25T J
R399,972 973	0B01888A	Carbon Resistor	10K ERD-25T J
R901,932	0B05743A	Carbon Resistor	27K ERD-25T J
R902	0B01857A	Carbon Resistor	1K ERD-25T J
R908	0B05509A	Carbon Resistor	33K ERD-25T J
R912,913	0B01854A	Carbon Resistor	39K ERD-25T J
R914,915	0B05675A	Carbon Resistor	3.9K ERD-25T J
R918,922	0B05629A	Carbon Resistor	2.7K ERD-25T J
R919,923 924	0B05577A	Carbon Resistor	330 ERD-25T J
R925,927	0B05776A	Carbon Resistor	1M ERD-25T J
R926,928	0B05671A	Carbon Resistor	2.2M ERD-25T J
R967,968	0B09214A	Fail Safe Type Resistor	1 RDF-25S J
C133,233	0B09187A	Electrolytic Capacitor	1 μ 50V (BP)
C335	0B09286A	Ceramic Capacitor	470P 50V K
C339,340	0B01405A	Electrolytic Capacitor	1 μ 50V
C342,343	0B01397A	Electrolytic Capacitor	1000 μ 16V
CN1,9	0B08656A	2P-T Post	
CN2,3,7 19	0B08654A	4P-T Post	
CN4,5	0B08183A	5P-T Post	
CN6,8,10	0B08642A	6P-T Post	
CN11,12	0B08645A	9P-T Post	
	0B07395A	Push Switch 6-6-0SUF34	(1 pce.)
	DE00507A	Nut Hex. M3	(2 pcs.)
	0E00510A	Screw M3x8 Philips Pan Head	(2A) (2 pcs.)
	0J04479A	Shield Case A	(1 pce.)
	0J04480A	Shield Case B	(1 pce.)
	0M04221A	Label CN-3	(1 pce.)
	0M04225A	Label CN-19	(1 pce.)
	0M04227A	Label CN-10	(1 pce.)
	0M04228A	Label CN-11	(1 pce.)
	0M04229A	Label CN-12	(1 pce.)
	0M04334A	Label CN-6	(1 pce.)
	0M04335A	Label CN-7	(1 pce.)
	0M04336A	Label CN-8	(1 pce.)

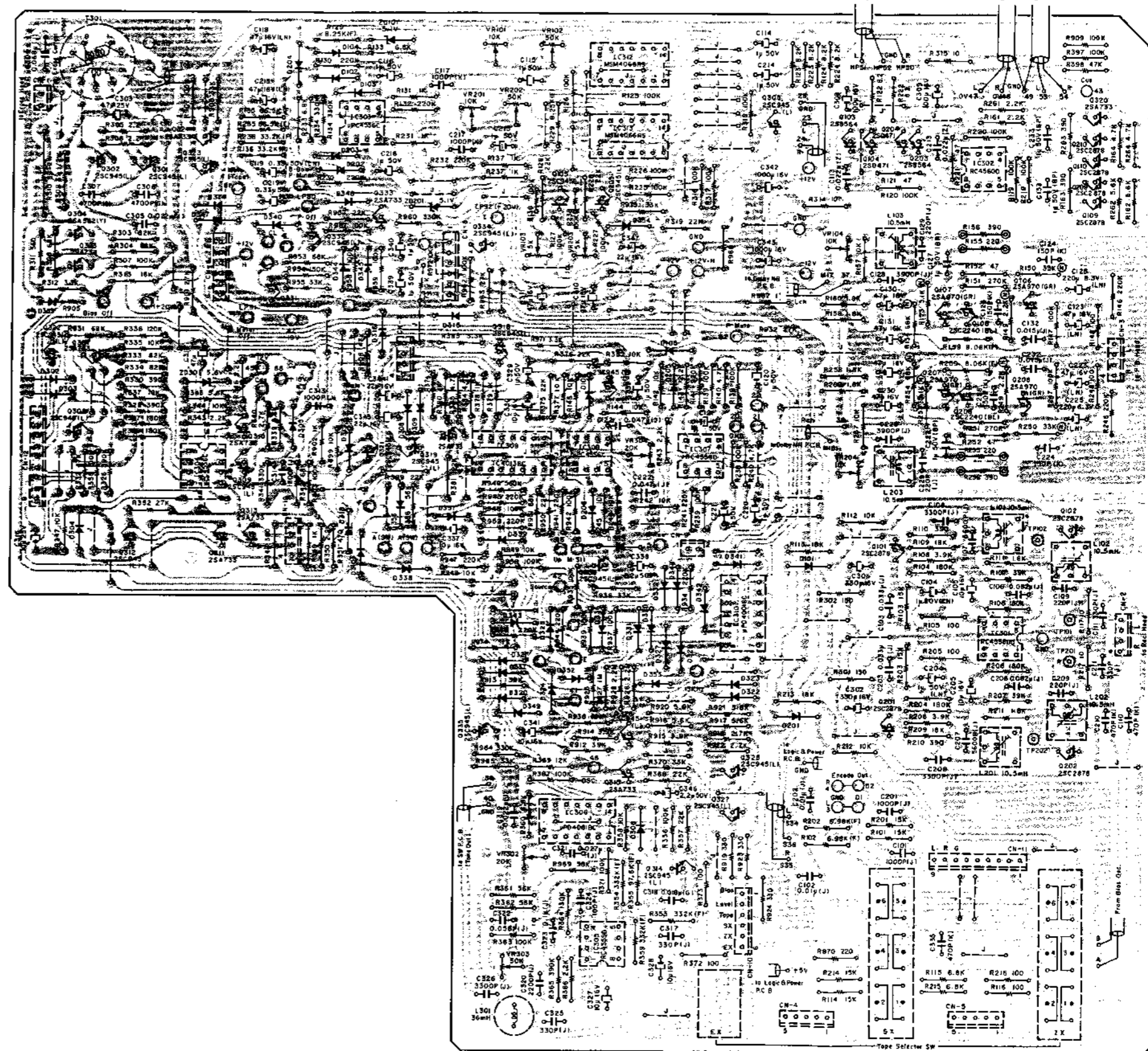
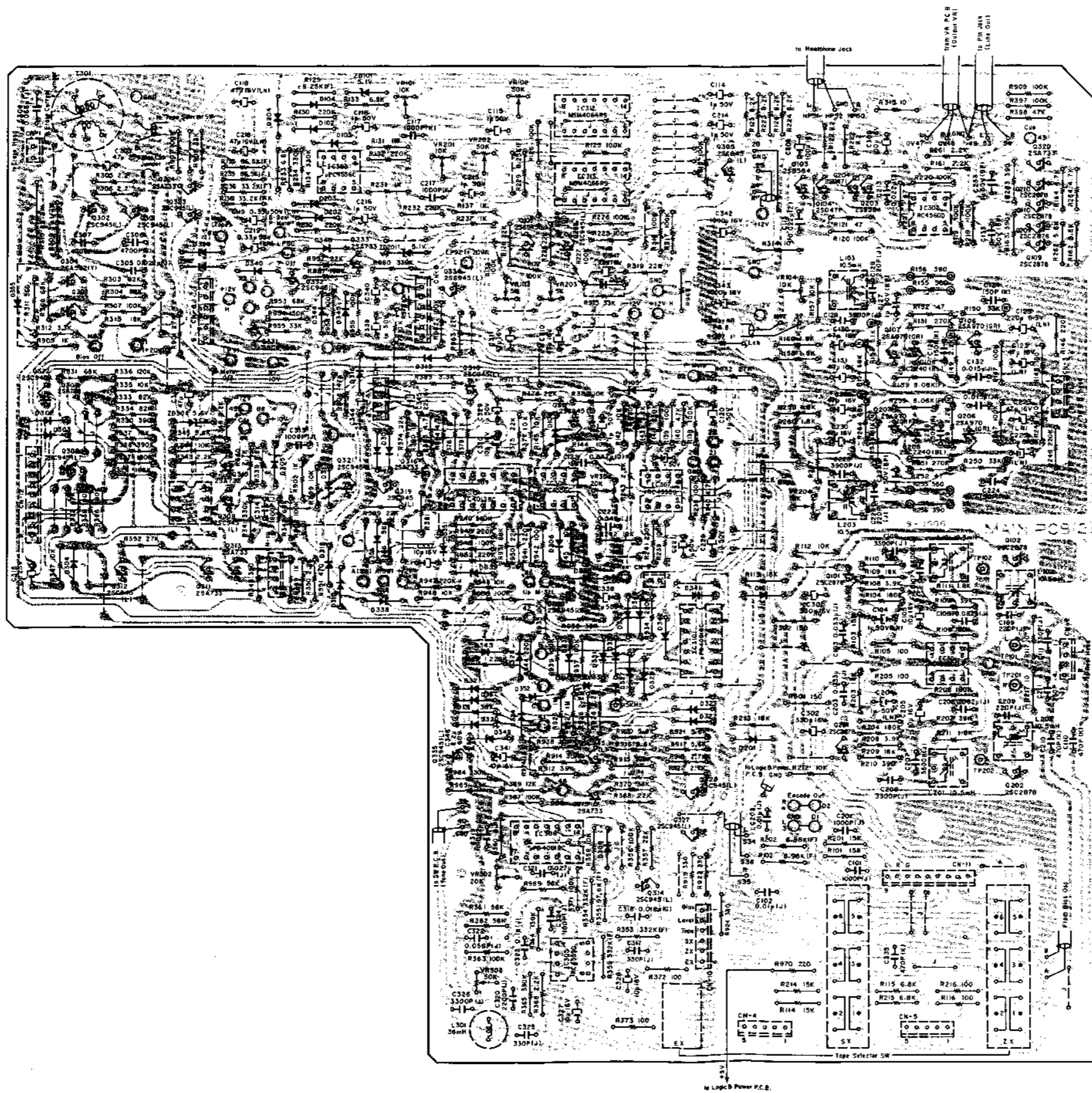

Fig. 7.14.2 Serial Nos.: A12403401 - A12404900 Note: Diode is 1S553, 1S953, or 1S1555 unless otherwise specified.



Schematic Ref. No.	Part No.	Description	
	BA04535A	Main P.C.B. Ass'y Serial Nos.: A12401001 - A12403400	
	- PB Eq. Amp. -		
Q106,107 206,207	0B06180A	Transistor	2SA970 (GR)
Q108,208	0B06142A	Transistor	2SC2240 (BL)
L103,203	0B00068A	Trap Coil	10.5mH
VR104,204	0B07233A	Semi-fixed Volume	10K
R146,246	0B05625A	Carbon Resistor	220K ERD-25T J
R147,247	0B01889A	Carbon Resistor	100K ERD-25T J
R148,248	0B01679A	Carbon Resistor	100 ERD-25T J
R149,249	0B09309A	Carbon Resistor	2.2K ERD-25TS J (Noiseless)
R150,250	0B09310A	Carbon Resistor	33K ERD-25TS J (Noiseless)
R151,251	0B05620A	Carbon Resistor	270K ERD-25T J
R152,252	0B01706A	Carbon Resistor	47 ERD-25T J
R153,253	0B09388A	Carbon Resistor	5.1K ERD-25TS J (Noiseless)
R154,254	0B09311A	Carbon Resistor	68K ERD-25TS J (Noiseless)
R155,255	0B05575A	Carbon Resistor	560 ERD-25T J
R156,256	0B05691A	Carbon Resistor	390 ERD-25T J
R157,257	0B01888A	Carbon Resistor	10K ERD-25T J
R158,160 258,260	0B05614A	Carbon Resistor	1.8K ERD-25T J
R159,259	0B09431A	Metal Film Resistor	8.06K SN14K2E F
C123,223	0B09218A	Electrolytic Capacitor	47μ 16V (LN)
C124,126 224,226	0B09281A	Ceramic Capacitor	150P 50V K
C125,225	0B09151A	Electrolytic Capacitor	220μ 6.3V (LN)
C127,227	0B09187A	Electrolytic Capacitor	1μ 50V (BP)
C128,228	0B01804A	Mylar Capacitor	3900P 50V J
C129,229	0B09247A	Mica Capacitor	220P 50V J
C130,131 230,231	0B01403A	Electrolytic Capacitor	47μ 16V
C132,232	0B05557A	Mylar Capacitor	0.015μ 50V J
	- Rec. Amp. -		
IC301	0B06146A	IC	RC4558DD
Q101,102 201,202	0B06299A	Transistor	2SC2878
D101,201	0B06181A	Silicon Diode	1SS53
L101,102 201,202	0B00068A	Trap Coil	10.5mH
R101,103 201,203	0B01683A	Carbon Resistor	15K ERD-25T J
R102,202	0B09604A	Metal Film Resistor	6.98K SN14K2E F
R104,106 204,206	0B05640A	Carbon Resistor	180K ERD-25T J
R105,116 205,216	0B01679A	Carbon Resistor	100 ERD-25T J
R107,207	0B01854A	Carbon Resistor	39K ERD-25T J
R108,208	0B05675A	Carbon Resistor	3.9K ERD-25T J
R109,113 209,213	0B05560A	Carbon Resistor	18K ERD-25T J
R110,210	0B05691A	Carbon Resistor	390 ERD-25T J
R111,211	0B05614A	Carbon Resistor	1.8K ERD-25T J
R112,212	0B01888A	Carbon Resistor	10K ERD-25T J
R114,214	0B01683A	Carbon Resistor	15K ERD-25T J

Fig. 7.14.3 Serial Nos.: A12401001 - A12403400 Note: Diode is 1SS53, 1S953, or 1S1555 unless otherwise specified.

8. MECHANISM ASS'Y AND PARTS LIST

8.1. Synthesis

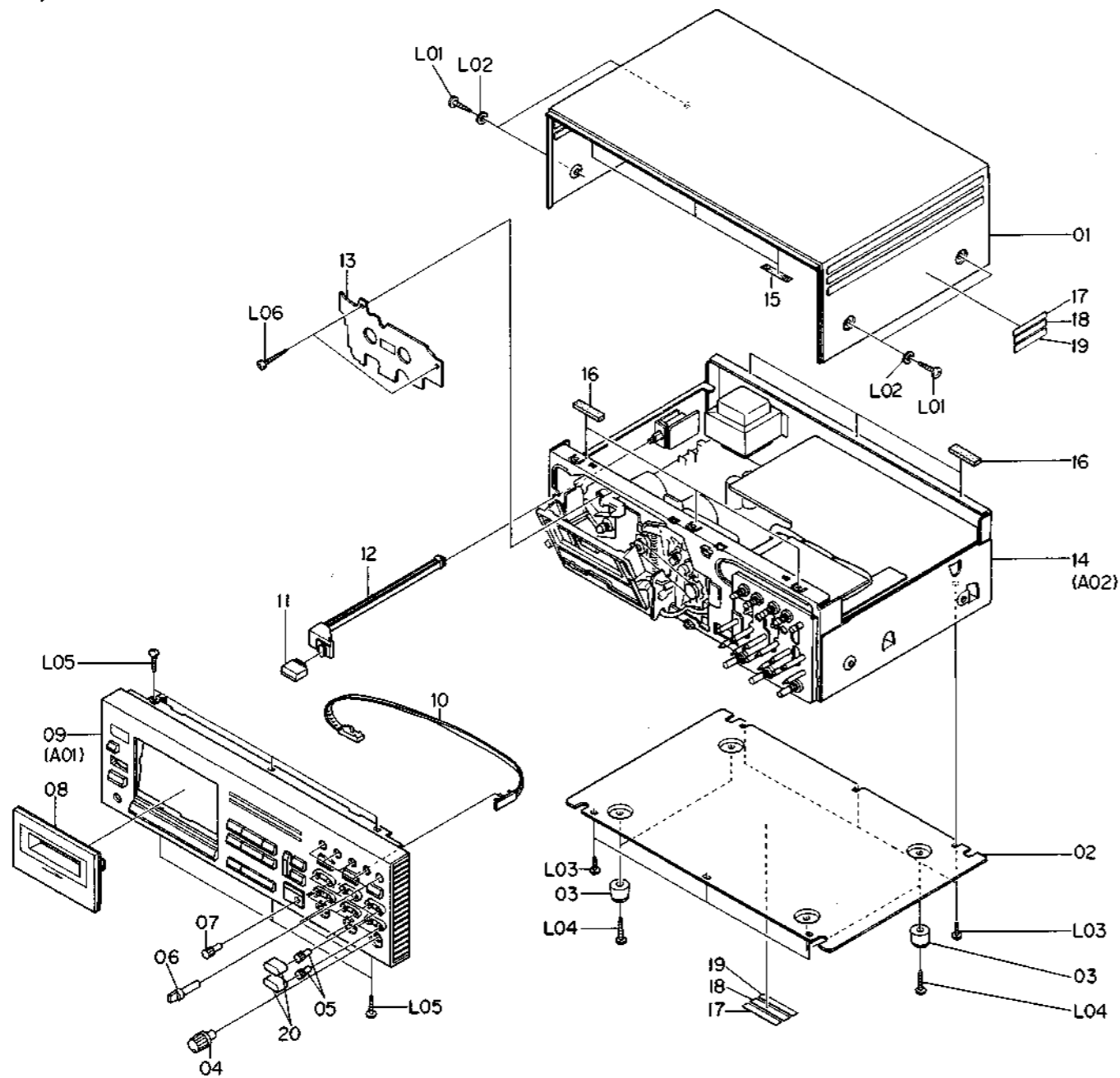

Fig. 8.1

8.2. Front Panel Ass'y (A01)

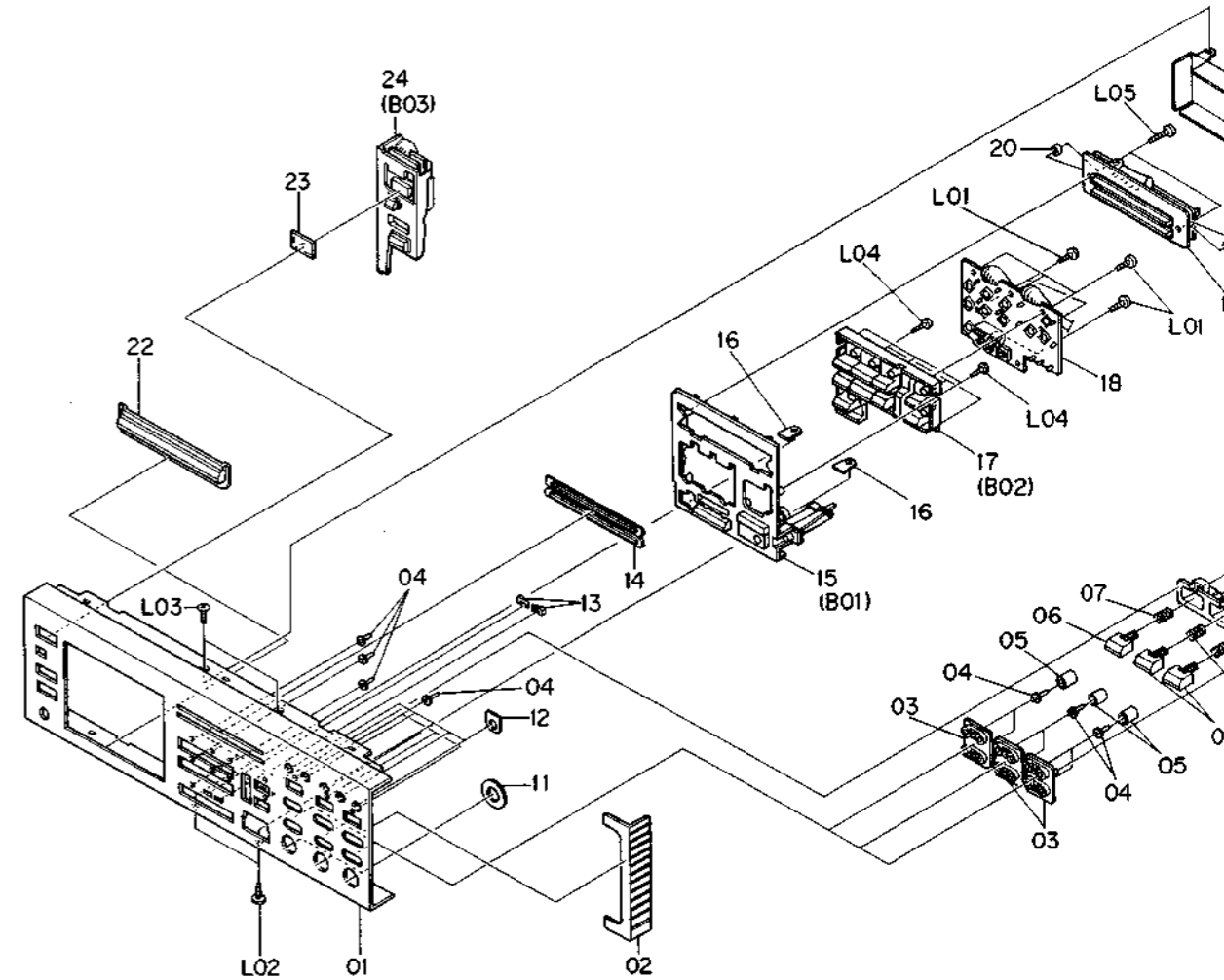

Fig. 8.2

Y AND PARTS LIST

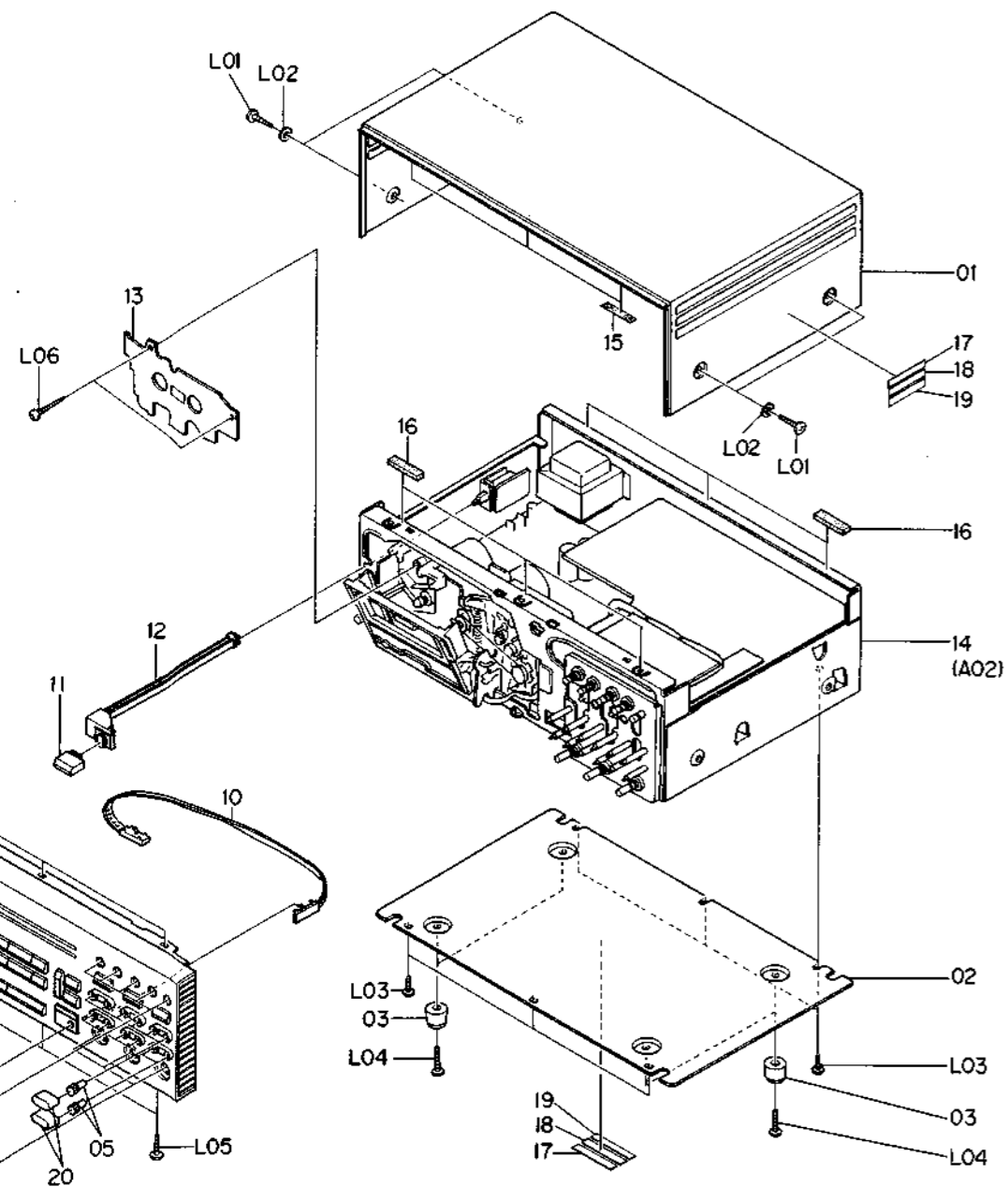

Fig. 8.1

8.2. Front Panel Ass'y (A01)

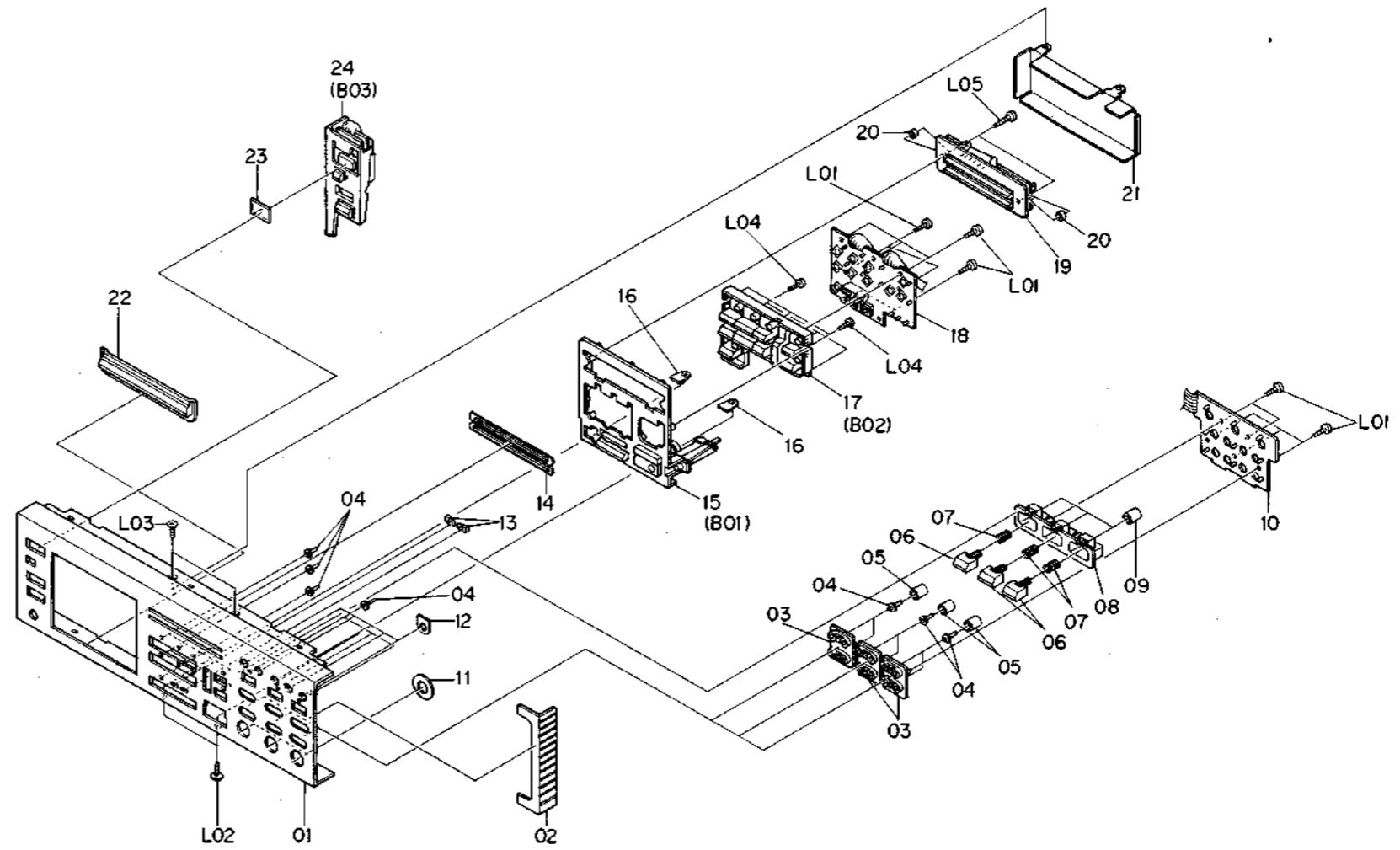

Fig. 8.2

Schematic Ref. No.	Part No.	Description	Q'ty	Schematic Ref. No.	Part No.	Description	Q'ty
	HA04210A	Synthesis (Japan)	1	A01	HA04216A	Front Panel Ass'y	1
	HA04211A	Synthesis (U.S.A. & Canada)	1			Serial No.:	
	HA04212A	Synthesis (220V Class 2)	1			A12401001 -	
	HA04213A	Synthesis (UK)	1				
	HA04214A	Synthesis (Australia)	1	01	0H04020B	Front Panel	1
	HA04215A	Synthesis (Others)	1	02	0H04001B	Side Cover	1
		Serial No.:		03	0H04056A	Cal. Volume Flange	3
		A12401001 -		04	0H03999A	LED Lens	18
				05	0J04496A	Cal. Volume Reflector	6
01	0H04010A	Top Cover	1	06	0H04021B	Selector Knob	3
02	0J04477A	Bottom Cover	1	07	0J04497A	Selector Spring	3
03	0J03564A	Leg T-H	4	08	0H04055A	Selector Flange	1
04	0H04028A	Control Volume Knob	3	09	0J04541A	Selector Reflector	3
05	0H04027A	Calibration Volume Knob	12	10	BA04545A	Record Cal. LED P.C.B. Ass'y	1
06	0H04025B	Function Knob	5	11	0H04002A	Volume Flange	3
07	0H04058A	Azimuth Alignment Knob	1	12	0H04029A	Function Flange	5
08	HA04229A	Cassette Case Ass'y	1	13	0H04031A	Fader Lens	2
09	HA04216A	Front Panel Ass'y	1	14	0H04000A	Meter Cover	1
10	0C08311A	Azimuth Wire	1	15	HA04230A	Front Escutcheon A Ass'y	1
11	0H04014A	Power Switch Knob	1	16	0J04486A	Panel Holder	2
12	0J04490B	Power Switch Joint	1	17	HA04226A	Control House Ass'y	1
13	0C08019I	Cover Plate	1	18	BA04544A	Control Switch P.C.B. Ass'y	1
14	JA03883A	Synthesis Mechanism Ass'y (Japan)	1	19	BA04543A	Indicator P.C.B. Ass'y	1
	JA03884A	Synthesis Mechanism Ass'y (U.S.A. & Canada)	1	20	0J04454A	Indicator P.C.B. Stud	2
	JA03885A	Synthesis Mechanism Ass'y (220V Class 2)	1	21	0J04458A	Meter Shield Case	1
	JA03886A	Synthesis Mechanism Ass'y (UK)	1	22	0H04023B	Cover Escutcheon	1
	JA03887A	Synthesis Mechanism Ass'y (Australia)	1	23	0H04030A	Counter Lens	1
	JA03888A	Synthesis Mechanism Ass'y (Others)	1	24	HA04225A	Front Escutcheon B Ass'y	1
15	0J04080A	Top Cover Himelon	3	L01	0E00862A	BT Screw M3x6 Philips Pan Head	12
16	0J04550A	Top Cover Cushion	6	L02	0E00593A	Screw M3x6 Philips Binding Head (Bronze)	2
17	0M03883B	Lamp Caution Label (U.S.A. & Canada)	1	L03	0E00505A	Screw M3x6 Philips Countersunk	2
18	0M03800A	Caution Label H (U.S.A. & Canada)	1	L04	0E00859A	BT Screw M2.6x6 Philips Binding Head	6
19	0M04314A	UL Caution Label (U.S.A. & Canada)	1	L05	0E00831A	BT Screw M3x10 Philips Pan Head	2
	0M04101B	Caution Label (UK, 220V Class 2, Australia, Japan & Others)	1				
L01	0E00915A	BT Screw M4x8 Philips Binding Head (Black Chromate)	4				
L02	0E00736A	Washer 4mm	4				
L03	0E00857A	BT Screw M3x6 Philips Binding Head	9				
L04	0E00865A	BT Screw M3x10 Philips Binding Head	4				
L05	0E00921A	BT Screw M3x8 Philips Binding Head (Black Chromate)	6				
L06	0E00950A	BT Screw M3x14 Philips Pan Head (Black Chromate)	2				

Schematic Ref. No.	Part No.	Description	Q'ty	Schematic Ref. No.	Part No.	Description	Q'ty
A02	JA03883A	Chassis Ass'y (Japan)	1	L05	0E00612A	BT Screw M3x6 Philips Pan Head (2A)	5
	JA03884A	Chassis Ass'y (U.S.A. & Canada)	1	L06	0E00962A	BT Screw M2x6 Philips Binding Head (Black Chromate)	1
	JA03885A	Chassis Ass'y (220V Class 2)	1				
	JA03886A	Chassis Ass'y (UK)	1	L07	0E00860A	BT Screw M3x6 Philips Binding Head (Black Chromate)	4
	JA03887A	Chassis Ass'y (Australia)	1				
	JA03888A	Chassis Ass'y (Others) Serial No.: A12401001 -	1				
				L08	-	Switch Nut A	(6)
				L09	-	Switch Washer A	(6)
				L10	-	Switch Nut B	(1)
				L11	-	Switch Washer B	(1)
01	JA03893A	Headphone Holder Ass'y	1				
02	OJ04135C	Mechanism Bracket	1				
03	OJ04478A	Sub Chassis	1				
04	BA04546A	Volume P.C.B. Ass'y	1				
05	BA04554A	Switch P.C.B. Ass'y	1				
06	OJ04478B	Front Chassis	1				
07	BA04547A	Azimuth Switch P.C.B. Ass'y	1				
08	OJ04502B	Cal. Volume Joint	12				
09	BA04542A	Record Cal. P.C.B. Ass'y	1				
10	0B02228B	Cassette Case Lamp	1				
11	OJ04506A	Lamp Holder	1				
12	OJ04469A	Cassette Case Plate	1				
13	CA08344A	Mechanism Ass'y ZX-7	1				
14	BA04618A	Power Switch P.C.B. Ass'y (U.S.A. & Canada)	1				
	BA04620A	Power Switch P.C.B. Ass'y (UK, 220V Class 2, Australia & Others)	1				
	BA04594A	Power Switch P.C.B. Ass'y (Japan)	1				
15	BA04535A	Main P.C.B. Ass'y	1				
16	OJ04470A	Side Chassis L	1				
17	OJ04472A	Center Chassis	1				
18	OJ04471A	Side Chassis R	1				
19	BA04575A	Dolby NR P.C.B. Ass'y (U.S.A. & Canada)	1				
	BA04646A	Dolby NR P.C.B. Ass'y (UK, 220V Class 2, Australia, Japan & Others)	1				
20	0B08771A	Hinge	2				
21	BA04621A	Logic & Power P.C.B. Ass'y (Japan)	1				
	BA04622A	Logic & Power P.C.B. Ass'y (U.S.A., Canada & Others)	1				
	BA04623A	Logic & Power P.C.B. Ass'y (UK, 220V Class 2 & Australia)	1				
22	HA04219A	Rear Panel Ass'y (Japan)	1				
	HA04220A	Rear Panel Ass'y (U.S.A. & Canada)	1				
	HA04221A	Rear Panel Ass'y (220V Class 2)	1				
	HA04222A	Rear Panel Ass'y (UK)	1				
	HA04223A	Rear Panel Ass'y (Australia)	1				
	HA04224A	Rear Panel Ass'y (Others)	1				
23	OJ04537B	Free Bushing 180mm	1				
24	OJ04543A	Free Bushing 60mm	1				
25	OJ04540A	Free Bushing 28mm	1				
26	0B08515A	Insh-Lock	30				
27	0B02542A	Cassette Case Lamp P.C.B.	1				
28	OJ04561A	Headphone Jack Cover	1				
L01	0E00857A	BT Screw M3x6 Philips Binding Head	31				
L02	0E00944A	BT Screw M4X15 Philips Binding Head (Black Chromate)	3				
L03	0E00924A	BT Screw M4x16 Philips Binding Head (Chromate)	1				
L04	0E00078A	Washer 4mm Toothed Lock	4				

8.3. Chassis Ass'y (A02)

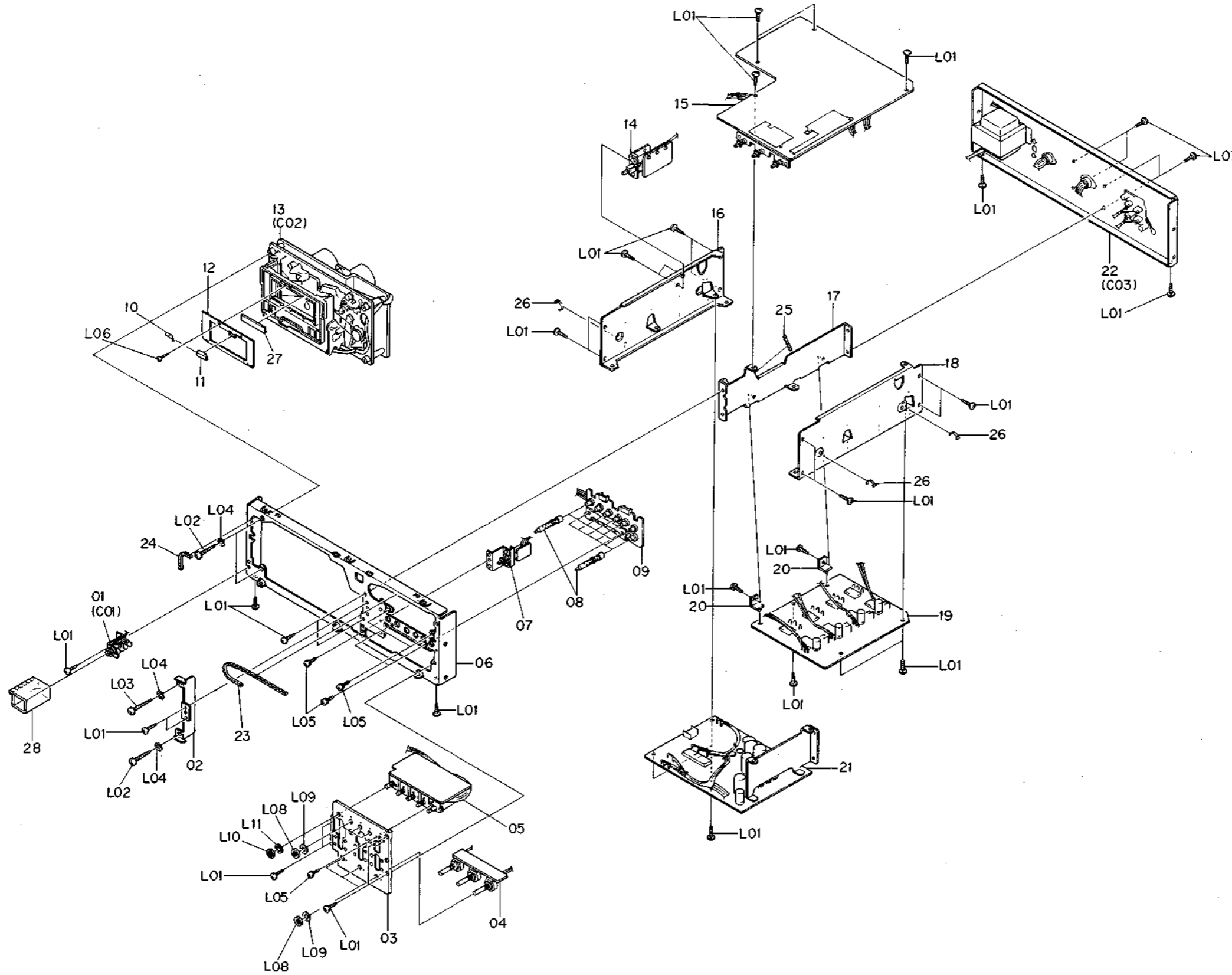

Fig. 8.3

8.4. Front Escutcheon A Ass'y (B01)

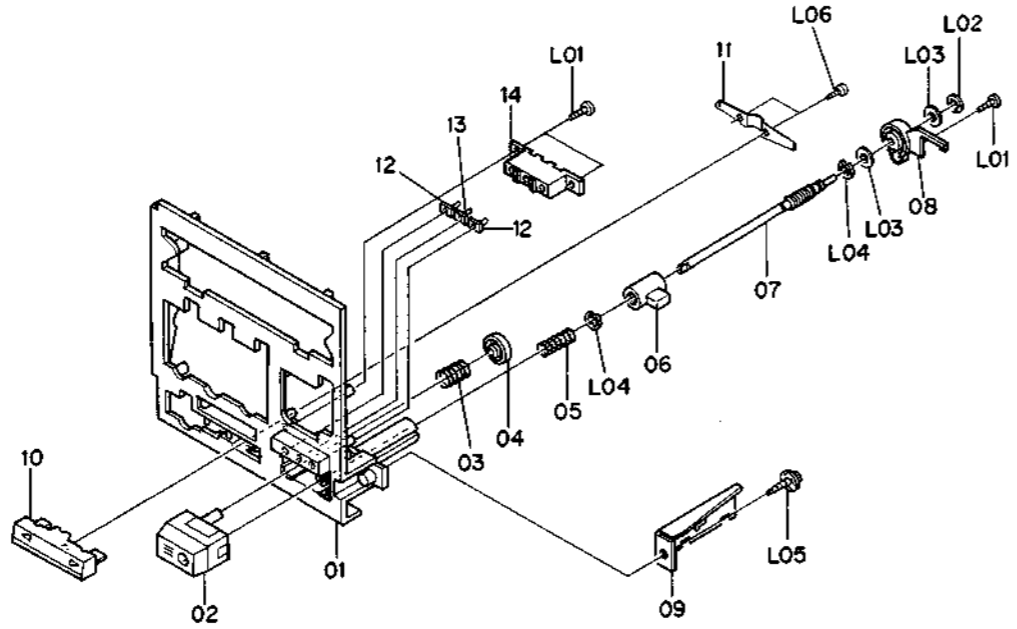

Fig. 8.4

8.5. Control House Ass'y (B02)

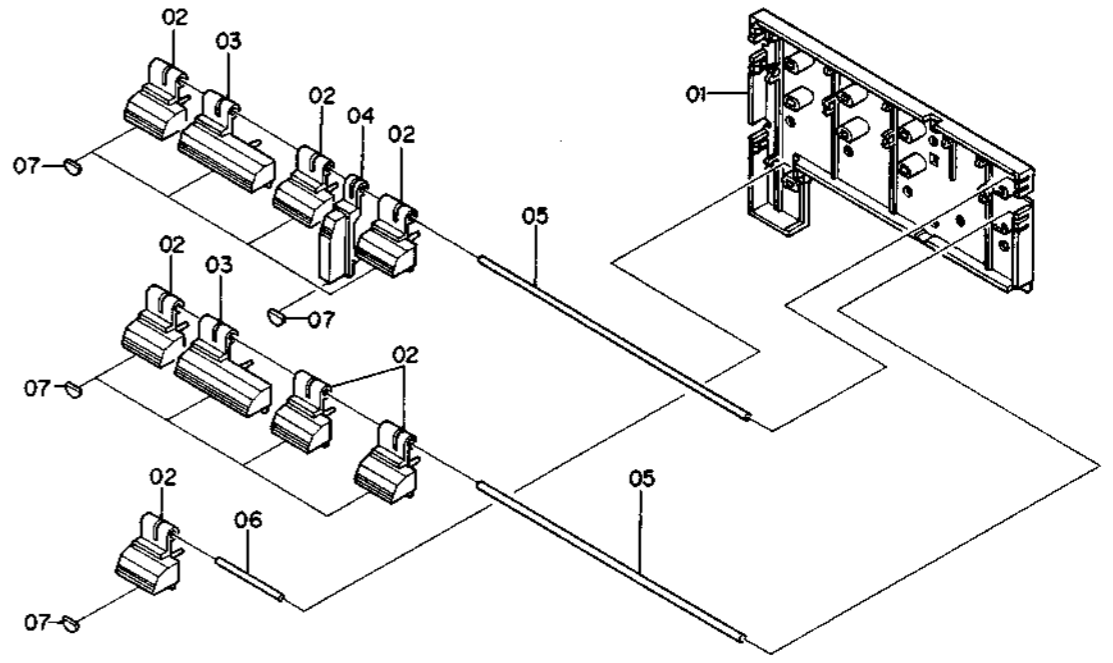

Fig. 8.5

Schematic Ref. No.	Part No.	Description	Q'ty	Schematic Ref. No.	Part No.	Description	Q'ty
B01	HA04230A	Front Escutcheon A Ass'y Serial No.: A12401001 -	1	05	OJ04493A	Shaft A	2
				06	OJ04494A	Shaft B	1
				07	OJ04495A	Control Cushion	10
01	OH04003B	Front Escutcheon A	1	B03	HA04225A	Front Escutcheon B Ass'y Serial No.: A12401001 -	1
02	HA04232A	Adjustment Cover Ass'y	1	01	OH04012B	Front Escutcheon B	1
03	OJ04459A	Adjustment Knob Spring	1	02	OH04015A	Eject Knob	1
04	OJ04460B	Adjustment Flange Stopper	1	03	OJ04488A	Eject Spring	1
05	OJ04464A	Adjustment Bar Spring	1	04	OJ04554B	Eject Cushion	1
06	OJ04462B	Adjustment Slide Joint	1	05	OJ04487B	Eject Stopper	1
07	OJ04463A	Adjustment Rod	1	06	OH04013A	Reset Switch Knob	1
08	OJ04461B	Adjustment Rod Stopper	1	07	OJ04489B	Reset Cushion	2
09	OJ04465A	Adjustment Wire Holder	1	08	BA04548A	Counter P.C.B. Ass'y	1
10	OH04004B	Fader Knob	1	09	BA04642A	Counter Control P.C.B. Ass'y	1
11	OJ04467B	Fader Spring	1	10	OJ04491A	Counter P.C.B. Stud	2
12	OH04005A	Adjustment Lens A	2	11	OJ04492B	Counter Shield Case	1
13	OH04006A	Adjustment Lens B	1	12	OJ04327A	Counter Himelon	1
14	OJ04466A	Adjustment Lamp House	1	13	OJ04563B	Counter P.C.B. Insulator	1
L01	0E00961A	BT Screw M2x5 Philips Binding Head (Chromate)	3	L01	0E00862A	BT Screw M3x6 Philips Pan Head	1
L02	0E00874A	Stopper Ring CS 2mm	1	L02	0E00883A	BT Screw M3x18 Philips Pan Head	2
L03	OJ04061A	Washer FT20	2	L03	0E00037A	Earth Lug B-5	1
L04	0E00222A	E-Ring 2mm	2	C01	JA03893A	Headphone Holder Ass'y Serial No.: A12401001 -	1
L05	0E00920A	Screw M3x6 Philips Pan Head Polywave	1	01	0B08511A	Headphone Jack	1
L06	0E00853A	BT Screw M2x3 Philips Pan Head	2	02	OJ04474A	Headphone Jack Holder	1
B02	HA04226A	Control House Ass'y Serial No.: A12401001 -	1	L01	-	Headphone Jack Washer	(1)
01	OH04016A	Control House	1	L02	-	Headphone Jack Nut	(1)
02	OH04017B	Control Knob A	7				
03	OH04018B	Control Knob B	2				
04	OH04019B	Control Knob C	1				

8.6. Front Escutcheon B Ass'y (B03)

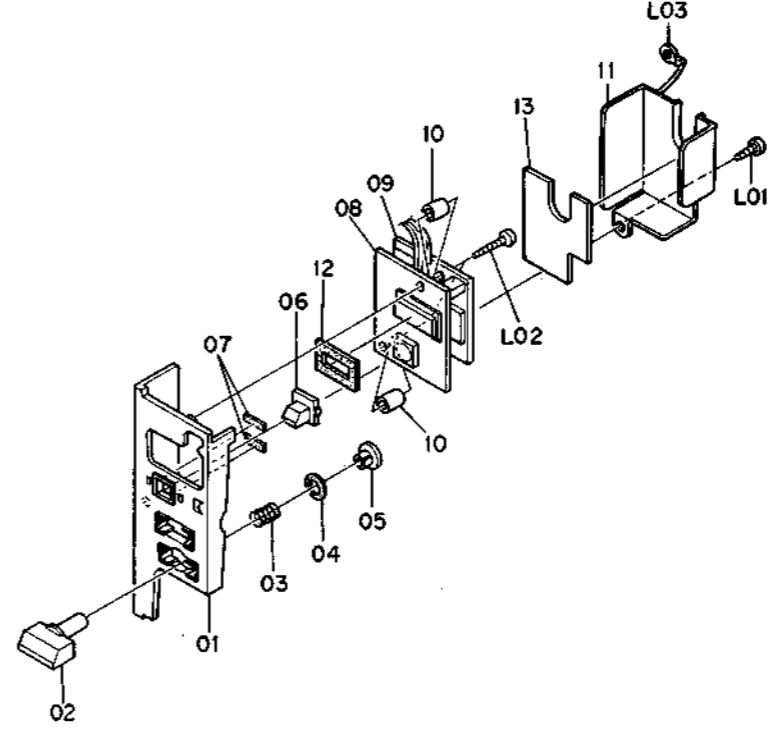

Fig. 8.6

8.7. Headphone Holder Ass'y (C01)

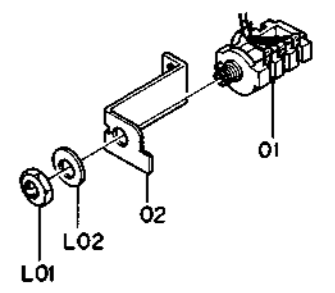

Fig. 8.7

8.8. Mechanism Ass'y ZX-7 (C02)

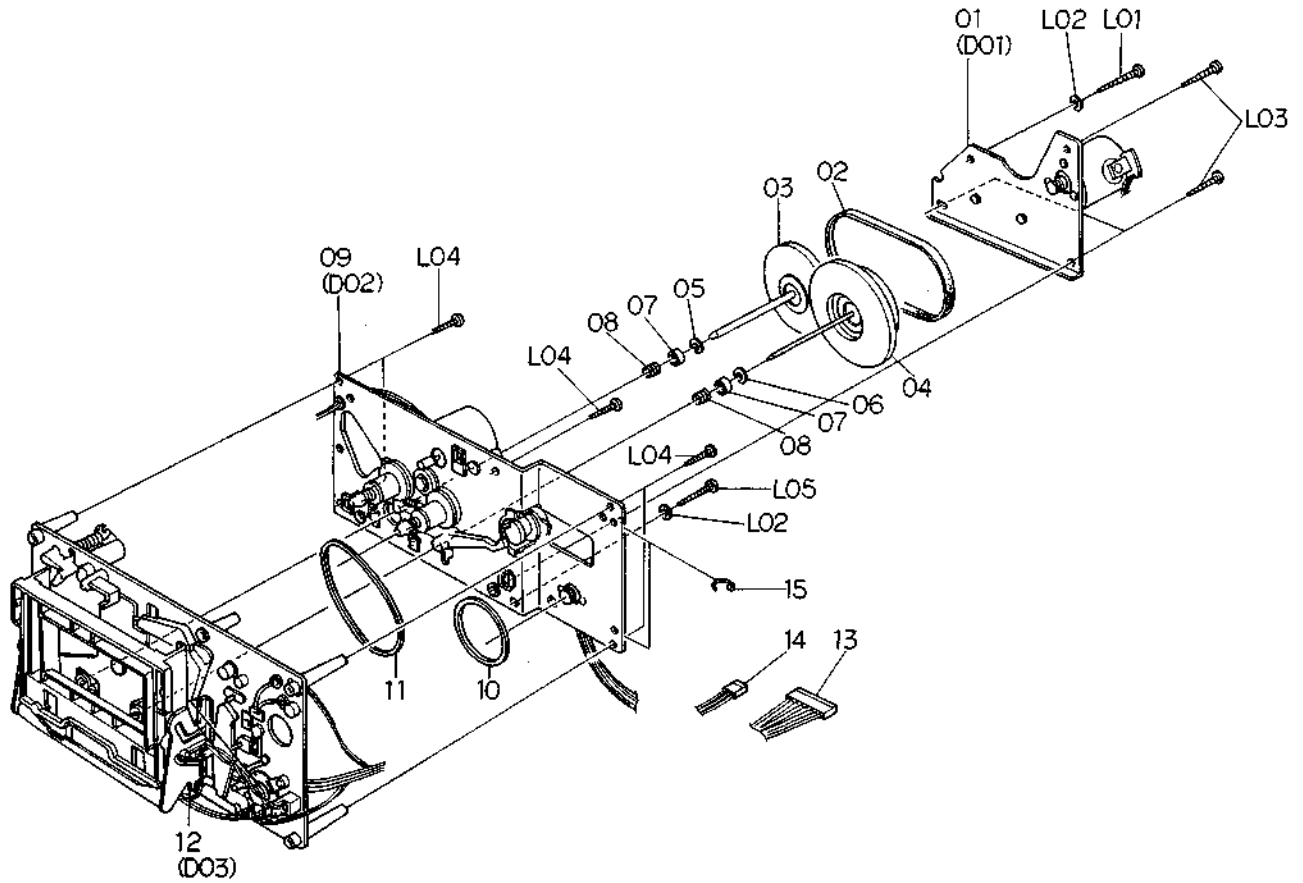

Fig. 8.8

Schematic Ref. No.	Part No.	Description	Q'ty
C02	CA08344A	Mechanism Ass'y ZX-7 Serial No.: A12401001 -	1
01	CA08017B	Flywheel Holder Ass'y	1
02	OC08096C	Capstan Belt	1
03	CA08173A	Supply Flywheel Ass'y D	1
04	CA08015A	Take-up Flywheel Ass'y	1
05	OC08021B	Thrust Washer 3.1mm	1
06	OC08020B	Thrust Washer 2.6mm	1
07	OC08243A	Flange Thrust Cap	2
08	OC08244A	Flange Thrust Spring	2
09	CA08343A	Sub Mechanism Chassis Ass'y	1
10	OC08099B	Control Motor Belt	1
11	OC08098B	Counter Belt B	1
12	CA08342A	Main Mechanism Chassis Ass'y	1
13	0B08943A	9P-H Connector	1
14	0B08672A	3P-H Connector	1
15	0B08515A	Insh-Lock	10
-	OM04326A	Mechanism Serial No. Seal	1
L01	0E00834A	BT Screw M3x30 Philips Pan Head	1
L02	0E00178A	Washer 3mm	2
L03	0E00833A	BT Screw M3x20 Philips Pan Head	3
L04	0E00883A	BT Screw M3x18 Philips Pan Head	5
L05	0E00835A	BT Screw M3x25 Philips Pan Head	1

Schematic Ref. No.	Part No.	Description	Q'ty	Schematic Ref. No.	Part No.	Description	Q'ty											
C03	HA04220A	Rear Panel Ass'y (U.S.A. & Canada)	1	D01	CA08017B	Flywheel Holder Ass'y Serial No.: A12401001 -	1											
	HA04219A	Rear Panel Ass'y (Japan)	1		01	OC08013I	Flywheel Holder	1										
	HA04224A	Rear Panel Ass'y (Others)	1			02	CA08106B	Capstan Motor Ass'y	1									
	HA04222A	Rear Panel Ass'y (UK)	1				L01	0E00226A	Screw M2.6x4 Philips Pan Head	3								
	HA04221A	Rear Panel Ass'y (220V Class 2)	1					L02	0C08068C	Thrust Screw	2							
	HA04223A	Rear Panel Ass'y (Australia) Serial No.: A12401001 -	1						L03	0C03857A	Lock Nut	2						
01	0H04009B	Rear Panel	1	D02						CA08343A	Sub Mechanism Chassis Ass'y Serial No.: A12401001 -	1						
02	BA04624A	Pin Jack P.C.B. Ass'y	1		01					OC08039B	Reel Hub Head	2						
03	BA04595A	4P DIN Socket Ass'y	1			02				CA08038B	Reel Hub B Supply Ass'y	2						
04	BA04596A	8P DIN Socket Ass'y	1				03			CA08037A	Reel Hub Take-up Ass'y	1						
05	0B06669A	Power Transformer (U.S.A. & Canada)	1					04		CA08064A	Reel Hub Supply Ass'y	1						
	0B06668A	Power Transformer (Japan)	1						05	CA08039A	Back Tension Ass'y	1						
	0B06670A	Power Transformer (Others)	1							06	0C08269A	Back Tension Spring C	1					
	0B06671A	Power Transformer (UK, Australia & 220V Class 2)	1								07	CA08193A	Idler Ass'y	1				
	06	OC01162B	Bolt Receptacle Plate									2	08	CA08042A	Brake Ass'y	2		
		07	0B08037U									Cord Bushing C (U.S.A., Canada, Japan, 220V Class 2, Australia & Others)		1	09	0C08030C	Brake Drive Arm	1
08	0B08351A	Cord Bushing 4K-4 (UK)	1									10		0C08129A		Brake Arm Spring	1	
	0B08533A	Power Cord (U.S.A., Canada & Others)	1											11		0C08128A	Brake Drive Arm Spring	1
	0B08219B	Power Cord (Japan)	1	12												CA08242A	Reel Motor Ass'y	1
	0B08348A	Power Cord (UK)	1		13											CA08034A	Control Motor Ass'y	1
	0B08093U	Power Cord (220V Class 2)	1			14										0C08053B	Volume Coupler	1
	0B05241A	Power Cord (Australia)	1				15									0B07240A	Volume Control 10K (B)	1
09	0J03663C	Switch Cover (U.S.A., Canada, Japan, 220V Class 2, UK & Australia)	1					16								CA08194A	Sub Chassis Ass'y	1
	0M03946A	Voltage Selector Lock Plate C (Others)	1						L01							0E00698A	E-Ring 2.5mm	1
	10	0M03551B	Pass Label							1						L02	0E00837A	Stopper Ring 3mm
		0M03797A	Voltage Label 240V (UK & Australia)							1	L03						0E00838A	Stopper Ring 4mm
		0M03796A	Voltage Label 220V (220V Class 2)							1			L04				0E00859A	BT Screw M2.6x6 Philips Binding Head
		0M04293A	Voltage Label 120V/220V-240V (Others)							1					L06		0E00226A	Screw M2.6x4 Philips Pan Head
12	0B07092U	Voltage Selector (Others)	1							L06		-					Volume Nut	(1)
	L01	0E00921A	BT Screw M3x8 Philips Binding Head (Black Chromate)									2		L07			-	Volume Washer
L02	0E00594A	Screw M3x8 Philips Binding Head (Bronze)	3															
L03	0E00172A	Washer 3mm Toothed Lock	1															
L04	0E00507A	Nut Hex. M3	3															
L05	0E00714A	Screw M2.6x6 Philips Binding Head (Bronze)	4															
L06	0E00953A	Screw M4x10 Philips Binding Head (Black Chromate)	2															
-	0J03644A	Chobert Rivet	2															
-	0M04316A	Serial Number Plate	1															
-	0F01071A	Free-up Belt	1															

8.9. Rear Panel Ass'y (C03)

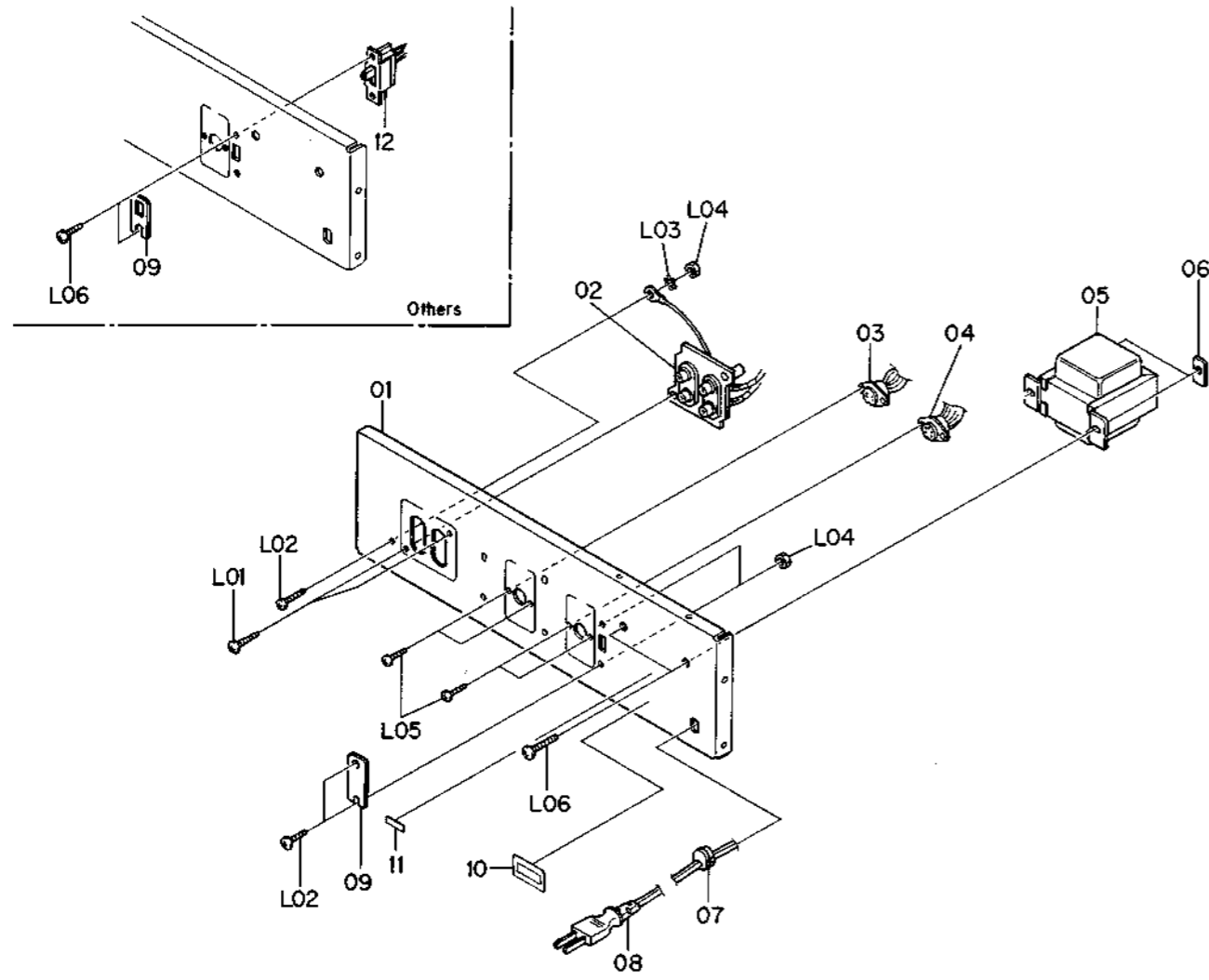

Fig. 8.9

8.10. Flywheel Holder Ass'y (D01)

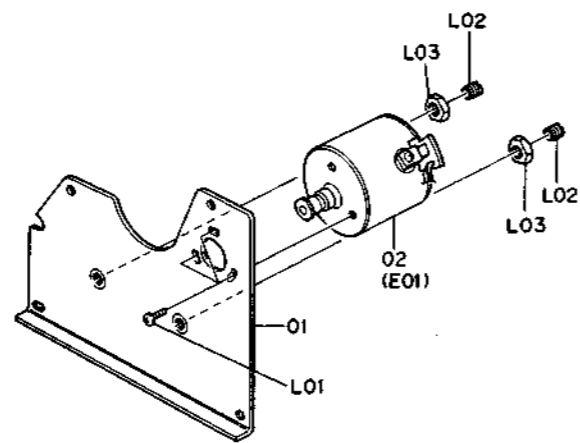

Fig. 8.10

8.11. Sub Mechanism Chassis Ass'y (D02)

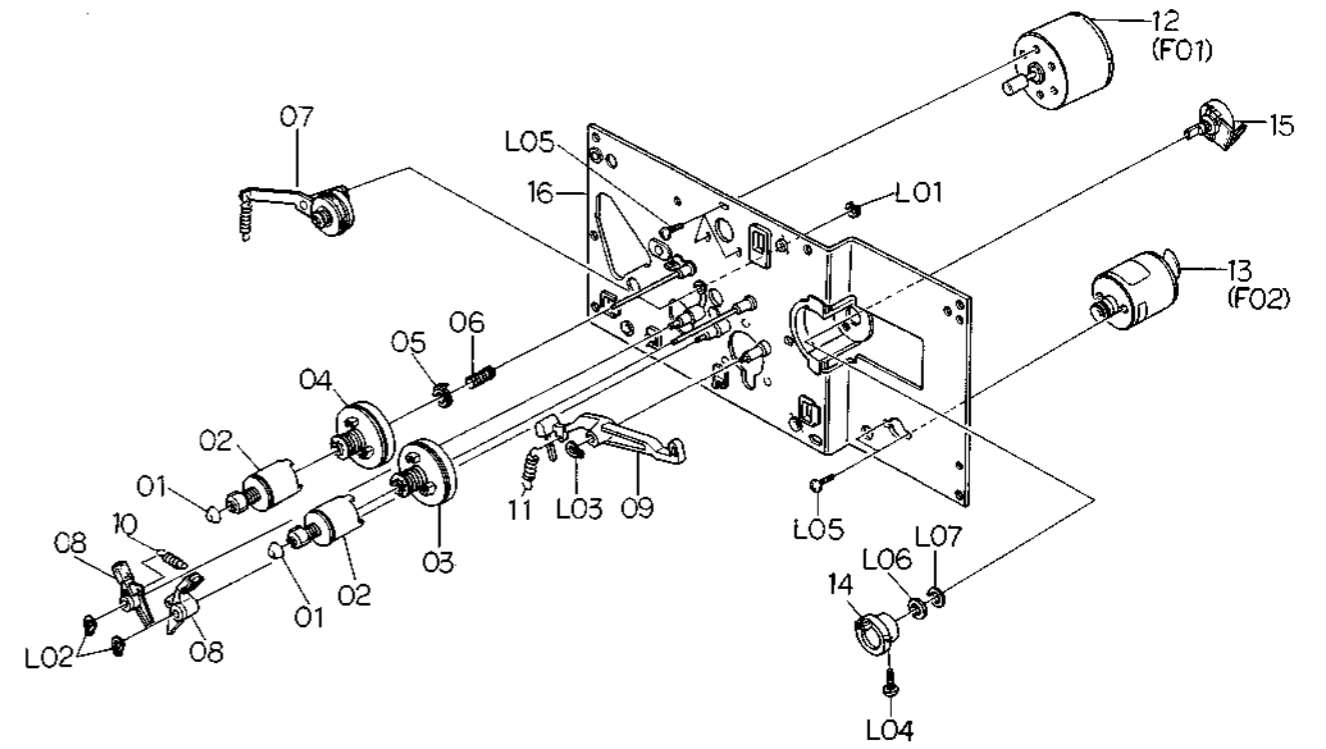

Fig. 8.11

Schematic Ref. No.	Part No.	Description	Q'ty
D03	CA08342A	Main Mechanism Chassis Ass'y Serial No.: A12401001 -	1
01	CA08350A	Cassette Case Holder L Ass'y	1
02	0C08151A	Lid Arm Spring Tube	1
03	CA08022A	Cassette Case Holder R Ass'y	1
04	CA08349A	Cassette Case Ass'y	1
05	CA08345A	Head Mount Base Ass'y	1
06	0C08121A	Supply Pressure Roller Spring	1
07	0C08250A	Supply Pressure Roller Spring B	1
08	0C08313A	Pressure Roller Arm Bushing	2
09	CA08053B	Supply Pressure Roller Ass'y	1
10	0C08122B	Supply Pressure Roller Thrust Spring	1
11	CA08079B	Take-up Pressure Roller Ass'y	1
12	0C08183B	Take-up Pressure Roller Thrust Spring	1
13	CA08339A	Head Base Ass'y	1
14	0C08182A	Pressure Roller Drive Bar B	1
15	0C08086B	Head Base Roller	1
16	0C08050B	Record Sensor	1
17	0C08051E	Cassette Hold Arm	1
18	0C08120A	Cassette Hold Arm Spring	1
19	CA08196A	Back Tension Ass'y	1
20	0C08254A	Back Tension Arm Collar	1
21	CA08027A	Head Base Drive Arm Ass'y	1
22	0C08143C	Head Base Drive Arm Spring	1
23	CA08026A	Pressure Roller Drive Arm Ass'y	1
24	CA08351A	Auto Shut-off Ass'y	1
25	0C08119A	Record Protector	1
26	0C08194C	Damper Lock Arm	1
27	0C08153A	Damper Lock Arm Spring Tube	1
28	0C08116A	Record Arm Spring	1
29	CA08030A	Pneumatic Damper Ass'y	1
30	CA08023A	Supply Capstan Flange Ass'y	1
31	CA08024A	Take-up Capstan Flange Ass'y	1
32	0C08186A	Cam Drive Gear	1
33	0C08029H	Control Cam	1
34	0C08117A	Counter-Load Arm Spring	1
35	0C08152A	Counter-Load Arm Spring Tube	1
36	CA08028A	Counter-Load Arm Ass'y	1
37	CA08347A	Main Chassis Ass'y	1
L01	0E00837A	Stopper Ring 3mm	9
L02	0E00834A	BT Screw M3x30 Philips Pan Head	2
L03	0E00831A	BT Screw M3x10 Philips Pan Head	3
L04	0E00254A	Washer 3.1mm	2
L05	0E00222A	E-Ring 2mm	2
L06	0E00876A	BT Screw M2.6x8 Philips Pan Head	8
L07	0E00178A	Washer 3mm	2
L08	0E00879A	BT Screw M2x15 Philips Pan Head	1
L09	0E00838A	Stopper Ring 4mm	3
L10	0E00846A	BT Screw M3x8 Philips Pan Head	3
L11	0E00895A	Earth Lug 3mm	2
L12	0E00859A	BT Screw M2.6x6 Philips Binding Head	1
L13	0C08255A	Washer 2.6mm	1

8.12. Main Mechanism Chassis Ass'y (D03)

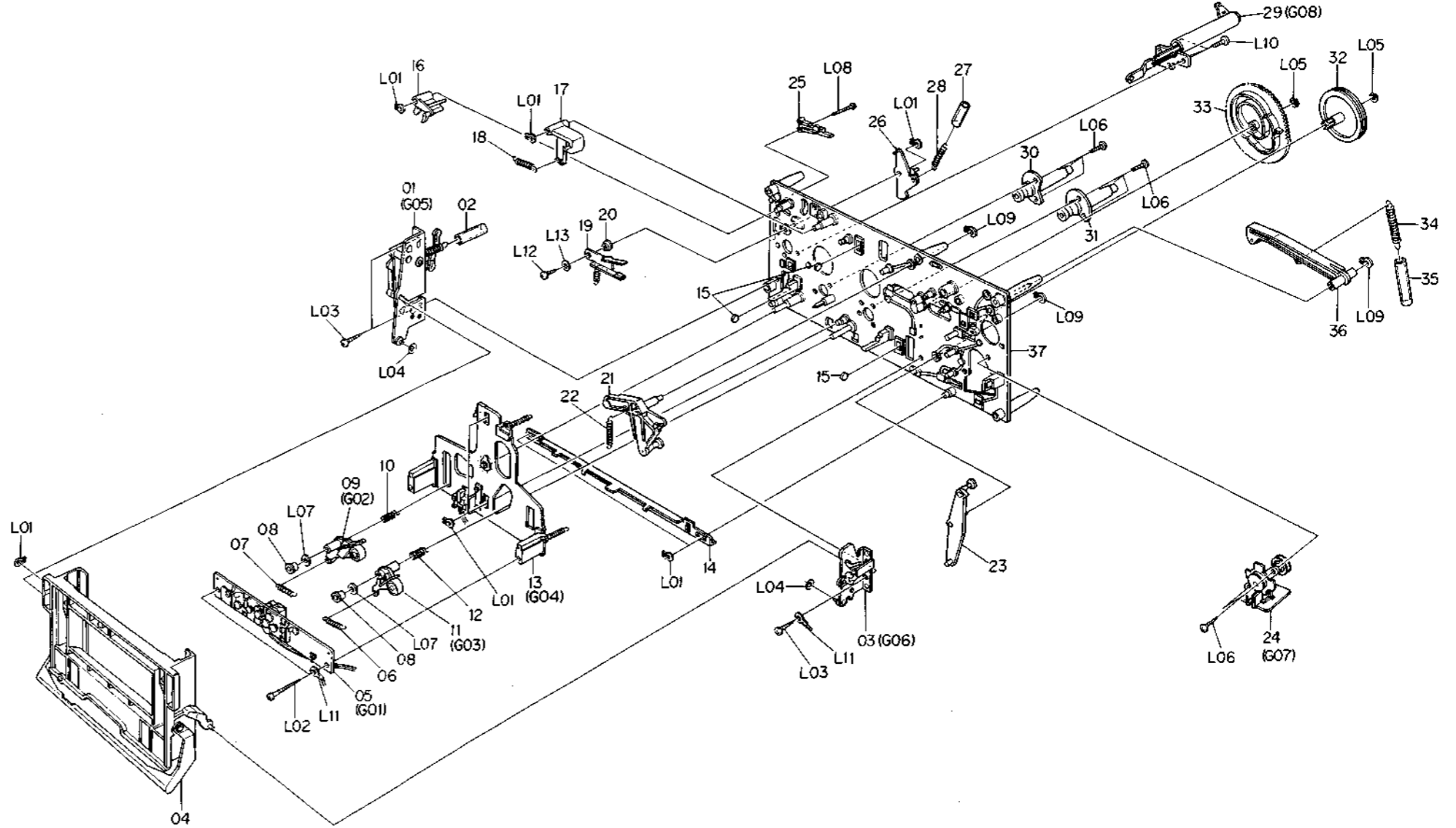

Fig. 8.12

8.13. Capstan Motor Ass'y (E01)

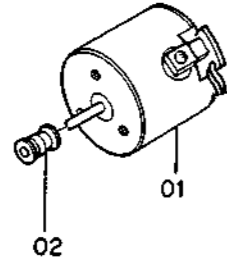

Fig. 8.13

8.14. Reel Motor Ass'y (F01)

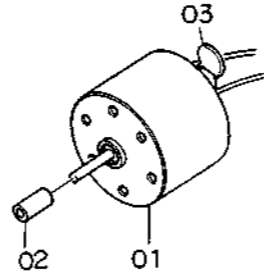

Fig. 8.14

8.15. Control Motor Ass'y (F02)

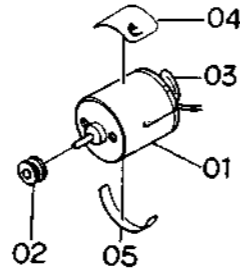

Fig. 8.15

8.16. Head Mount Base Ass'y (G01)

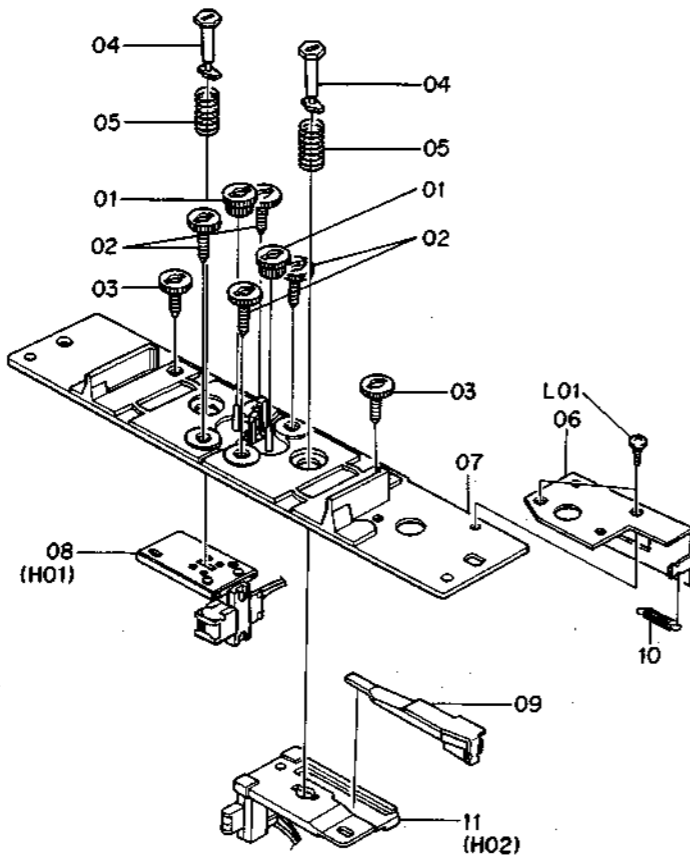

Fig. 8.16

8.17. Supply Pressure Roller Ass'y (G02)

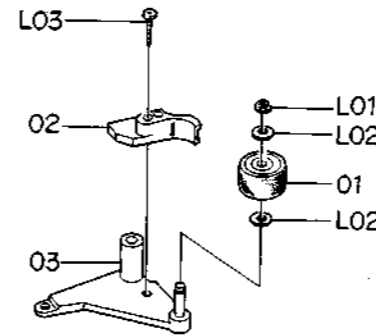

Fig. 8.17

8.18. Take-up Pressure Roller Ass'y (G03)

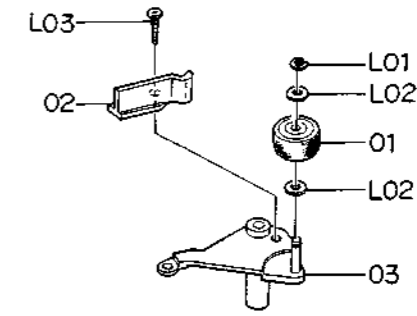

Fig. 8.18

Schematic Ref. No.	Part No.	Description	Q'ty	Schematic Ref. No.	Part No.	Description	Q'ty
E01	CA08106B	Capstan Motor Ass'y Serial No.: A12401001 -	1	G02	CA08053B	Supply Pressure Roller Ass'y Serial No.: A12401001 -	1
01	0C08135A	Capstan Motor	1	01	0C08164G	Pressure Roller	1
02	0C08079G	Capstan Motor Pulley	1	02	0C08189C	Supply Tape Guide	1
F01	CA08242A	Reel Motor Ass'y Serial No.: A12401001 -	1	03	CA08061A	Supply Pressure Roller Arm Ass'y	1
01	0C08272A	Reel Motor	1	L01	0E00042A	E-Ring 1.5mm	1
02	0C08063F	Reel Motor Pulley	1	L02	0C08024A	Washer 2mm	2
03	0B09290A	Ceramic Capacitor 0.01μ 50V Z	1	L03	0E00788A	BT Screw M2x8 Philips Pan Head (Black Chromate)	1
F02	CA08034A	Control Motor Ass'y Serial No.: A12401001 -	1	G03	CA08079B	Take-up Pressure Roller Ass'y Serial No.: A12401001 -	1
01	0C08137A	Control Motor	1	01	0C08164G	Pressure Roller	1
02	0C08064A	Control Motor Pulley	1	02	0C08181C	Take-up Tape Guide	1
03	0B09292A	Ceramic Capacitor 0.1μ 50V Z	1	03	CA08073B	Take-up Pressure Roller Arm Ass'y	1
04	0M03985A	Control Motor Label	1	L01	0E00042A	E-Ring 1.5mm	1
05	0M03988A	Motor Seal B	1	L02	0C08024A	Washer 2mm	2
G01	CA08345A	Head Mount Base Ass'y Serial No.: A12401001 -	1	L03	0E00788A	BT Screw M2x8 Philips Pan Head (Black Chromate)	1
01	0C08028C	Head Height Adjustment Gear	2				
02	0C08027F	Head Height Adjustment Screw	4				
03	0C08026D	Azimuth Alignment Screw	2				
04	0C08161B	Spring Stopper	2				
05	0C08187B	Head Plate Spring	2				
06	0C08315A	Azimuth Alignment Wire Hold Plate	1				
07	CA08083C	Head Mount Base Sub Ass'y	1				
08	CA08341A	P-8L Playback Head Ass'y	1				
09	0C08316A	Azimuth Alignment Plate	1				
10	0C08317A	Azimuth Spring	1				
11	CA08340A	R-8L Record Head Ass'y	1				
L01	0E00917A	BT Screw M2.6x5 Philips Pan Head	2				

8.19. Head Base Ass'y (G04)

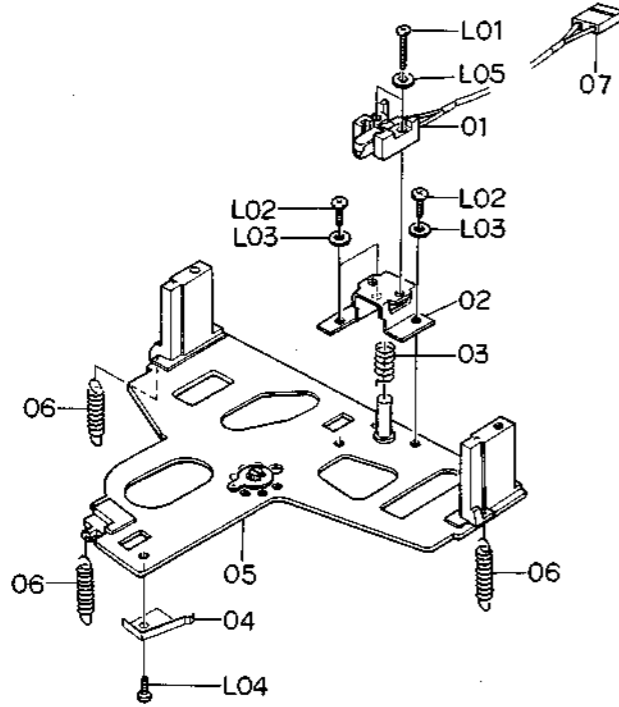

Fig. 8.19

8.20. Cassette Case Holder L Ass'y (G05)

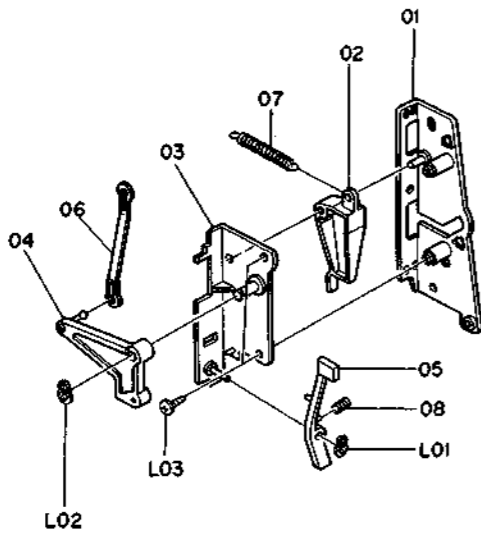

Fig. 8.20

8.21. Cassette Case Holder R Ass'y (G06)

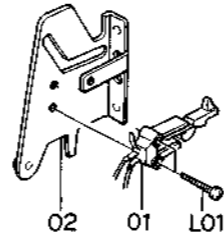

Fig. 8.21

8.22. Auto Shut-off Ass'y (G07)

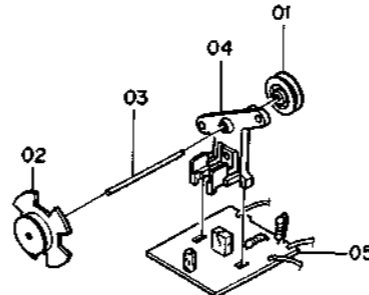

Fig. 8.22

8.23. Pneumatic Damper Ass'y (G08)

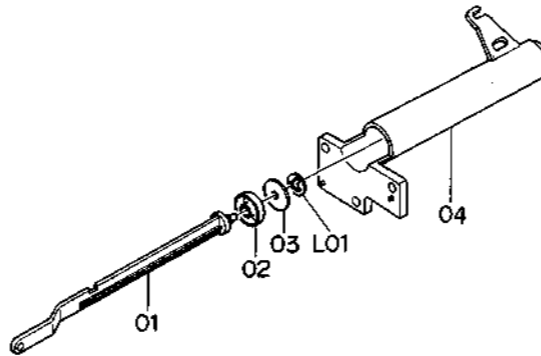

Fig. 8.23

8.24. P-8L Playback Head Ass'y (H01)

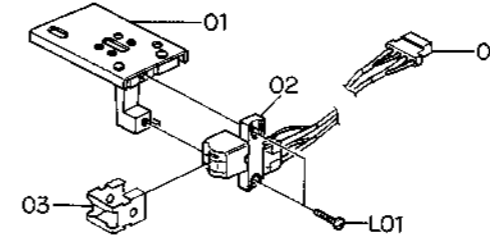

Fig. 8.24

8.25. R-8L Record Head Ass'y (H02)

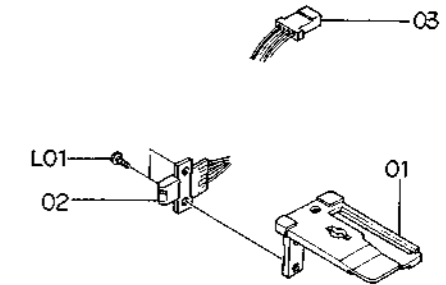

Fig. 8.25

Schematic Ref. No.	Part No.	Description	Q'ty	Schematic Ref. No.	Part No.	Description	Q'ty
G04	CA08339A	Head Base Ass'y Serial No.: A12401001 -	1	G07	CA08351A	Auto Shut-off Ass'y Serial No.: A12401001 -	1
01	GA02103A	EOK Erase Head	1	01	OC08047A	Shut-off Pulley A	2
02	OC08158D	Erase Head Hold Plate	1	02	OC08309A	Shut-off Pulley B	1
03	OC08166A	Erase Head Hold Plate Spring	1	03	OC08088B	Shut-off Pulley Shaft	1
04	OC08174D	Cassette Hold Spring	1	04	OC08207B	Shut-off Pulley Holder	1
05	CA08003Q	Head Base Ass'y	1	06	BA04551A	Shut-off P.C.B. Ass'y	1
06	OC08175A	Head Base L Spring	3	G08	CA08030A	Pneumatic Damper Ass'y Serial No.: A12401001 -	1
07	OB08944A	2P-H Connector	1	01	OC08058C	Damper Piston	1
L01	OE00951A	Screw M1.7x7 Philips Pan Head (Black Chromate)	2	02	OC08102C	Damper Ring	1
L02	OE00909A	Screw M2x6 Philips Pan Head	3	03	OC08010C	Damper Plate	1
L03	OE00117A	Washer 2mm	3	04	OC08059D	Sylinder	1
L04	OE00853A	BT Screw M2x3 Philips Pan Head	1	L01	OE00874A	Stopper Ring CS 2mm	1
L05	OE00852A	Washer 1.7mm	2	H01	CA08341A	P-8L Playback Head Ass'y Serial No.: A12401001 -	1
G05	CA08350A	Cassette Case Holder L Ass'y Serial No.: A12401001 -	1	01	CA08307A	Playback Head Plate Ass'y	1
01	CA08326A	Cassette Case Holder L Sub Ass'y	1	02	GA02034A	P-8LH Playback Head	1
02	OC08073C	Lid Arm A	1	03	OC08169D	Pad Lifter 54	1
03	OC08306A	Eject Arm Holder	1	04	OB08946A	4P-H Connector	1
04	OC08307A	Eject Arm A	1	L01	OE00886A	Screw M1.7x6.5 Philips Pan Head	2
05	OC08197C	Eject Arm B	1	H02	CA08340A	R-8L Record Head Ass'y Serial No.: A12401001 -	1
06	OC08199B	Eject Arm Joint	1	01	OC08234B	Record Head Plate	1
07	OC08114A	Lid Arm Spring	1	02	GA01050A	R-8LH Record Head	1
08	OC08211C	Eject Arm Spring	1	03	OB08945A	4P-H Connector	1
L01	OE00837A	Stopper Ring 3mm	1	L01	OE00887A	Screw M1.7x4 Philips Pan Head	2
L02	OE00838A	Stopper Ring 4mm	1				
L03	OE00865A	BT Screw M3x10 Philips Binding Head	2				
G06	CA08022A	Cassette Case Holder R Ass'y Serial No.: A12401001 -	1				
01	OC08133A	Eject Sensor	1				
02	CA08044A	Cassette Case Holder R Sub Ass'y	1				
L01	OE00840A	BT Screw M2x8 Philips Pan Head	2				

9. OVERALL TIMING CHART

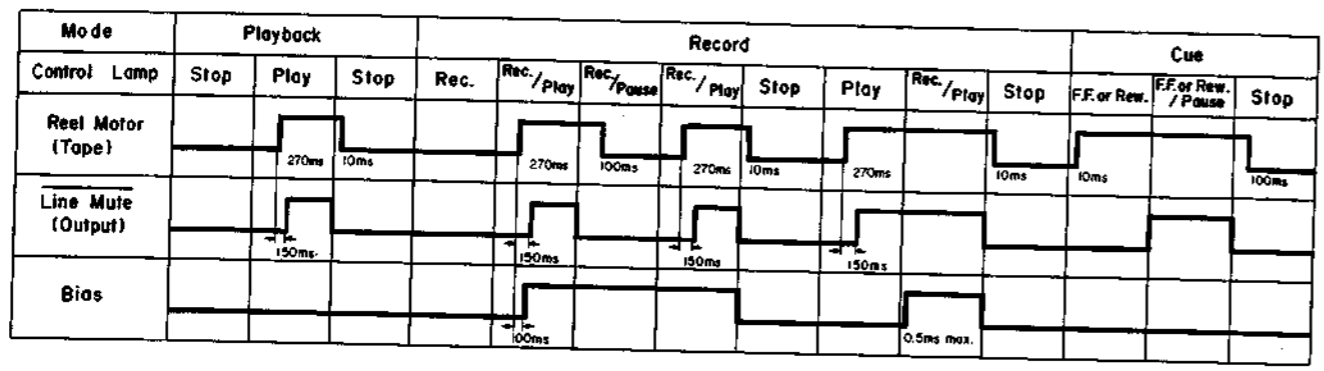

Fig. 9

10. EQ. AMP. FREQUENCY RESPONSE

10.1. Playback Frequency Response

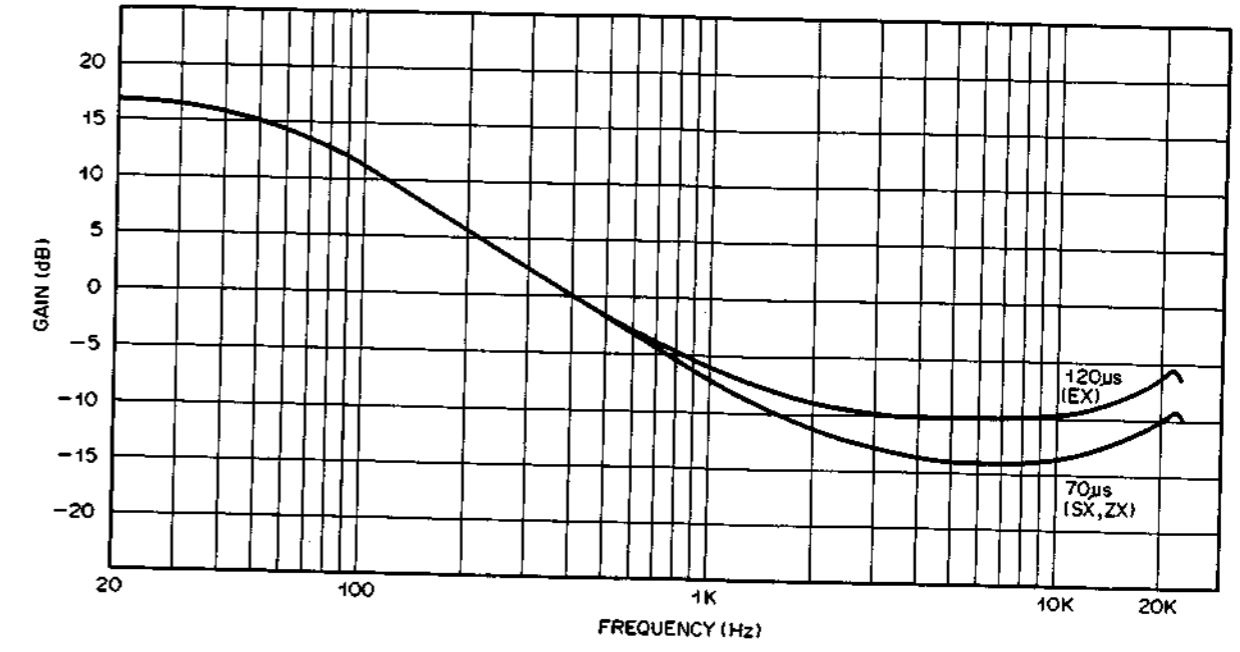

Fig. 10.1

10.2. Record Current Frequency Response

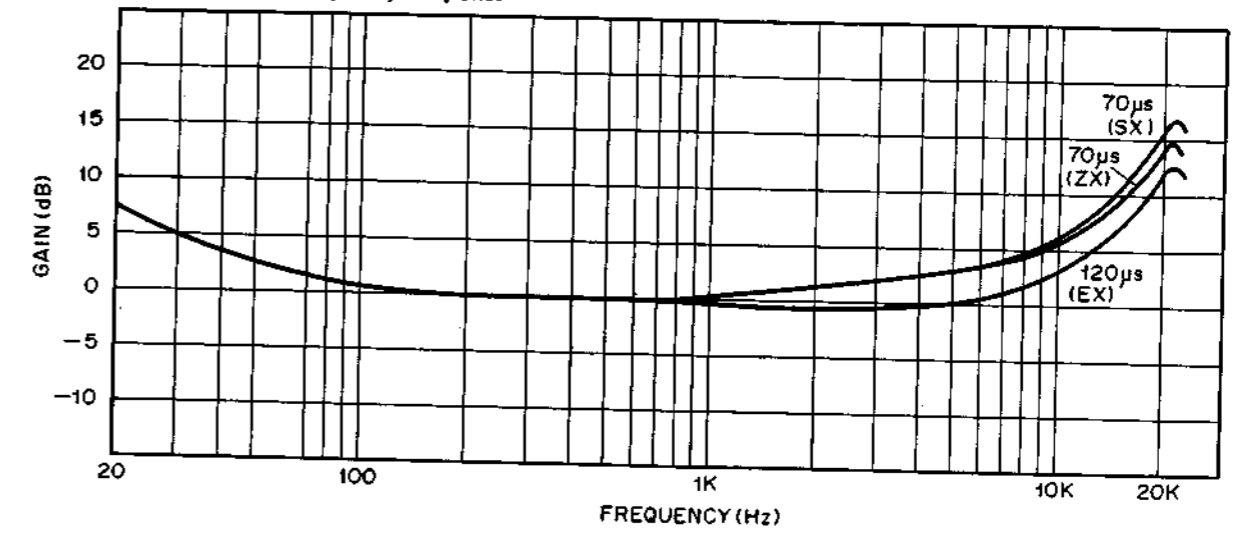

Fig. 10.2

11. BLOCK DIAGRAMS

11.1. Amplifier Section

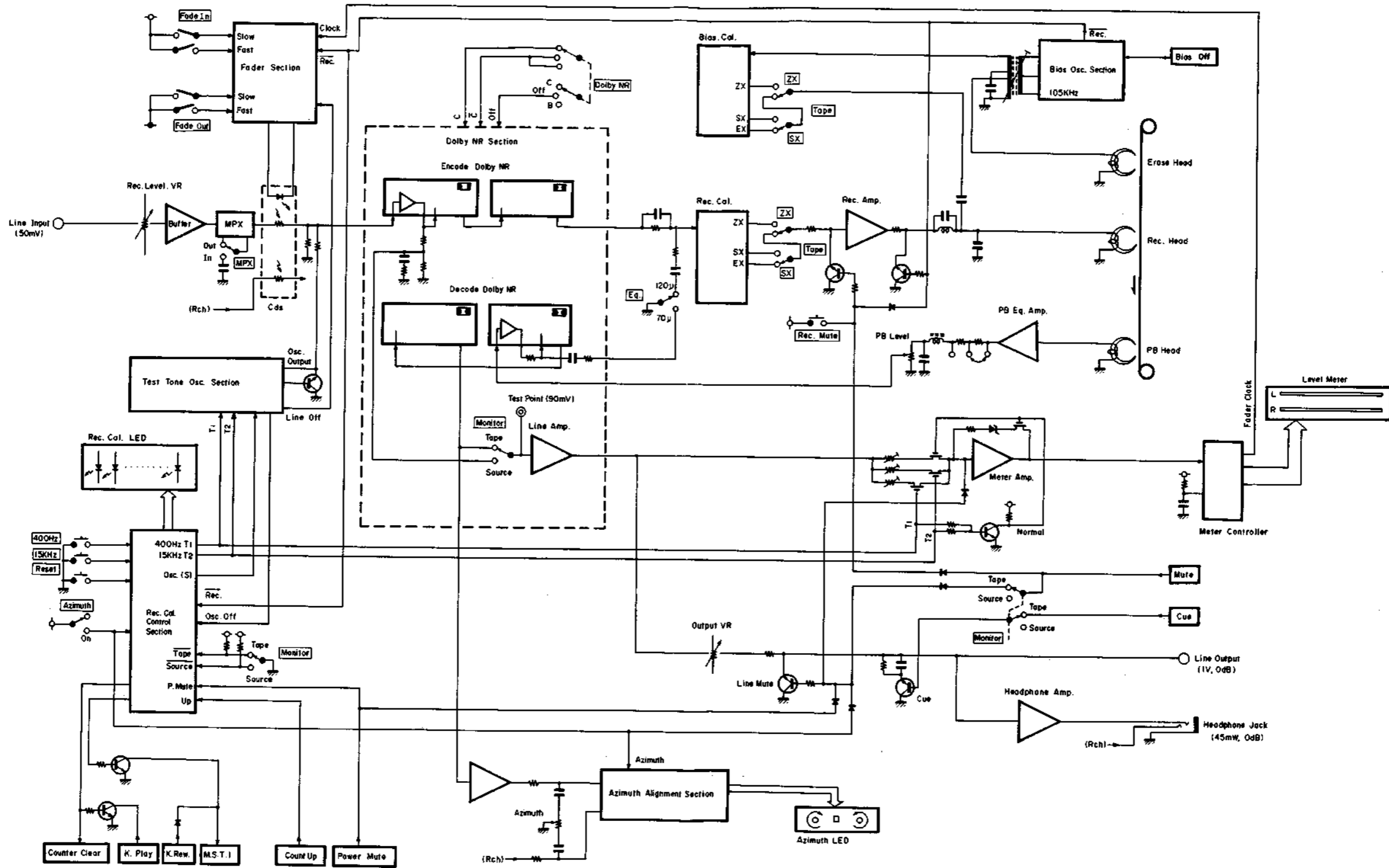

Fig. 11.1

11.2. Mechanism Control Section

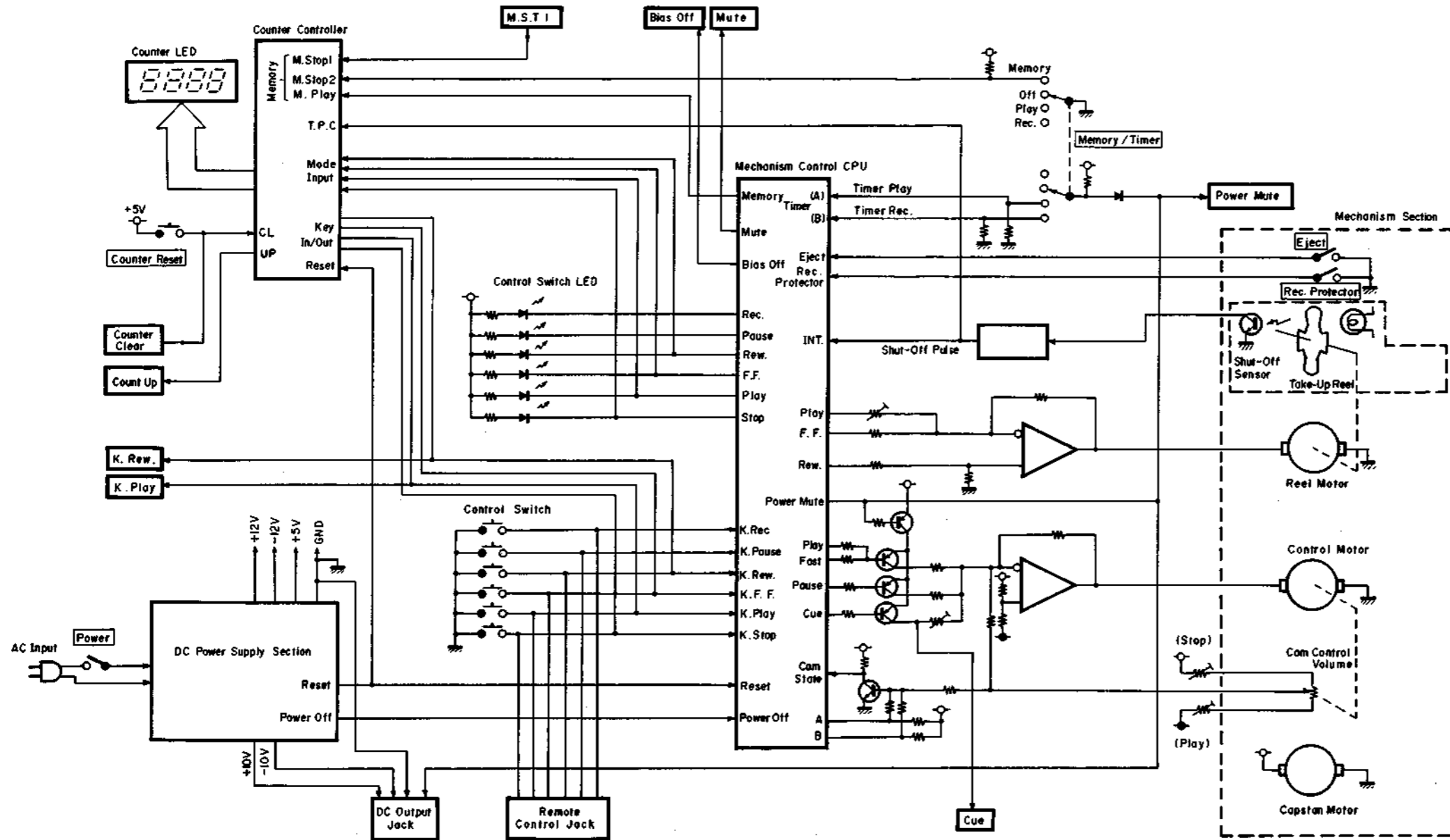

Fig. 11.2

12. WIRING DIAGRAM

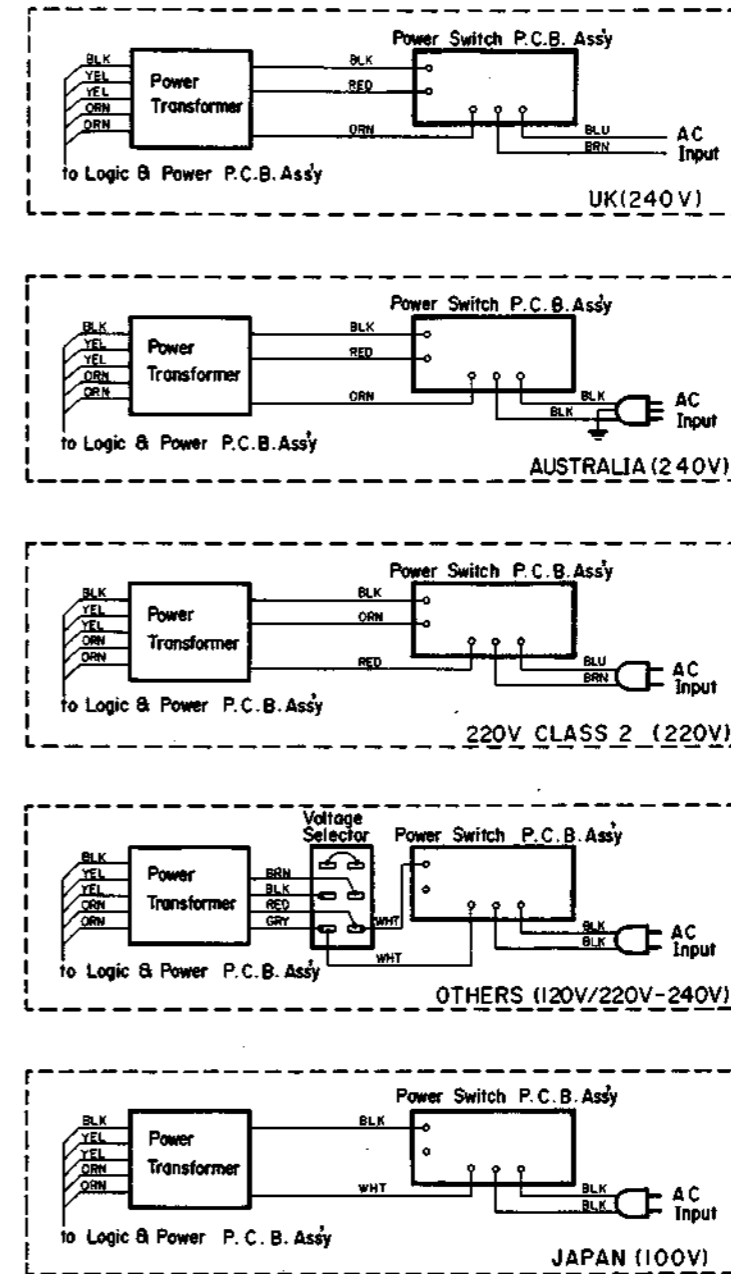
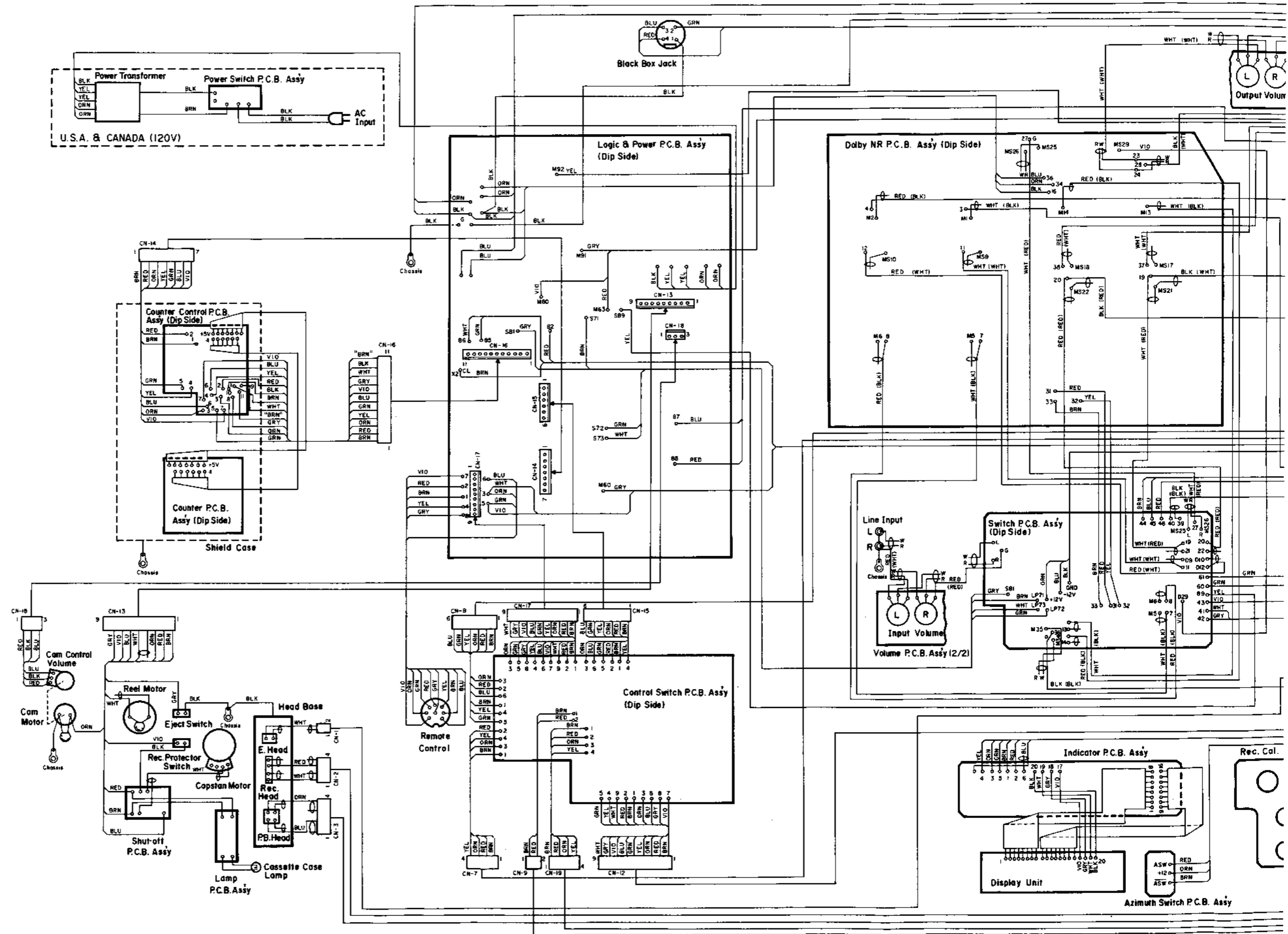

Fig. 12.1



- Notes: 1. Table of wire colors
 BLK - Black
 BLU - Blue
 ORN - Orange
 GRY - Gray
 GRN - Green
 RED - Red
 BRN - Brown
 YEL - Yellow
 WHT - White
 VIO - Violet
2. Wire tube color is shown in ().
3. Component side view of the P.C.B. is illustrated unless otherwise specified.

Fig. 12.2

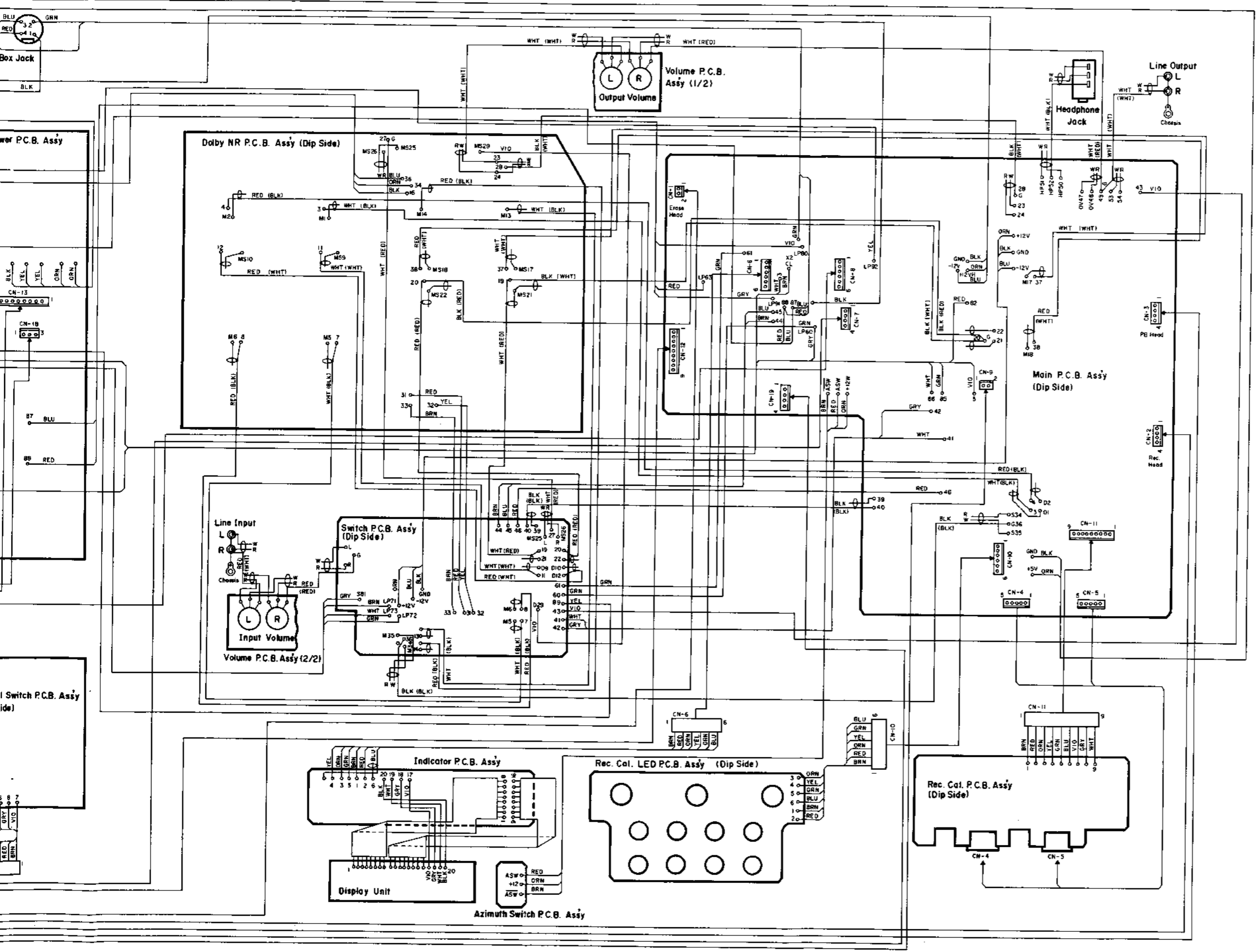

Fig. 12.2

Notes: 1. Diode is 1SS53, 1S953, or 1S1555 unless otherwise specified.
 2. Resistor and capacitor marked with * show typical value.

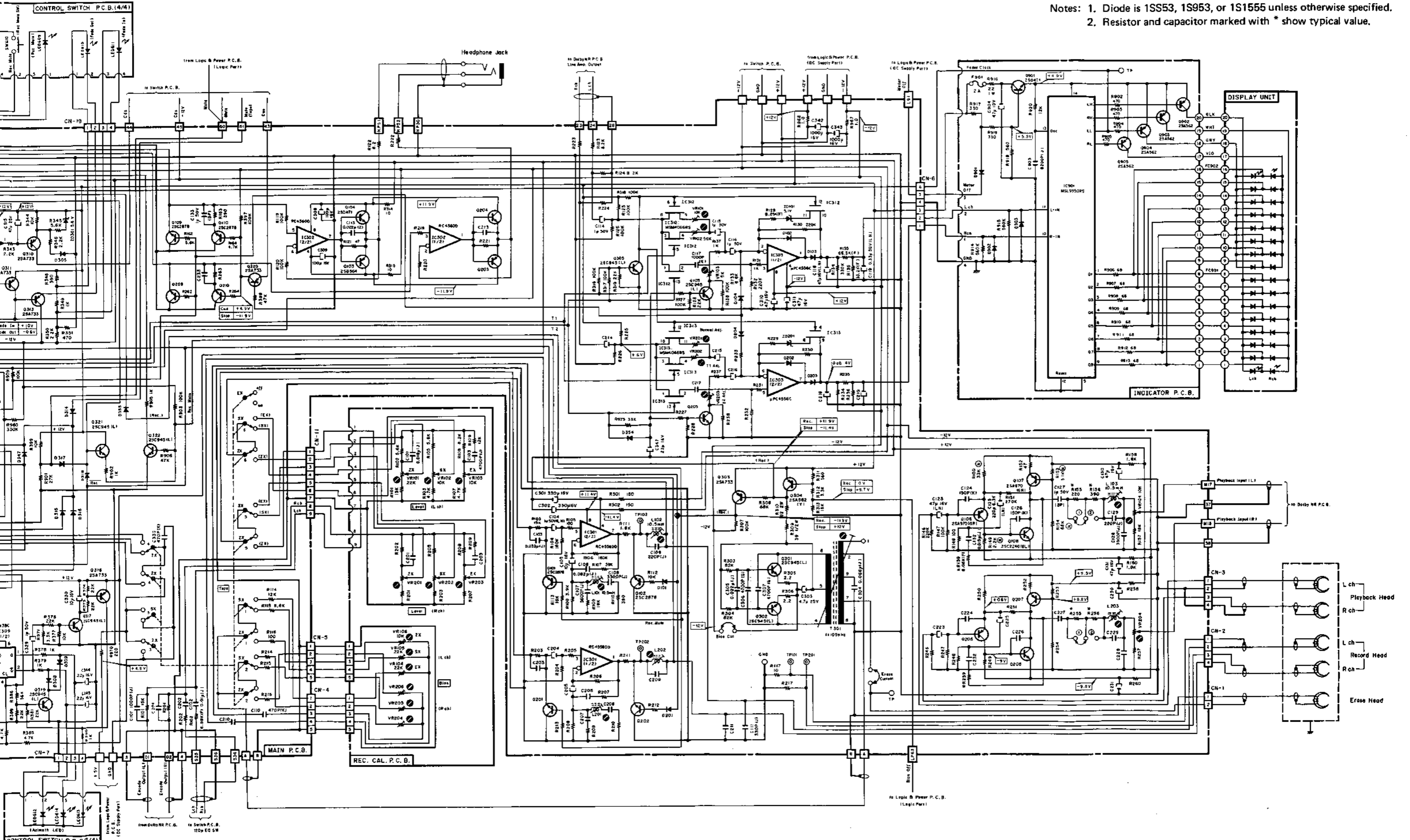

Fig. 13.1

13.2 Dolby NR Section
 13.2.1. Dolby NR Section (U.S.A. & Canada)

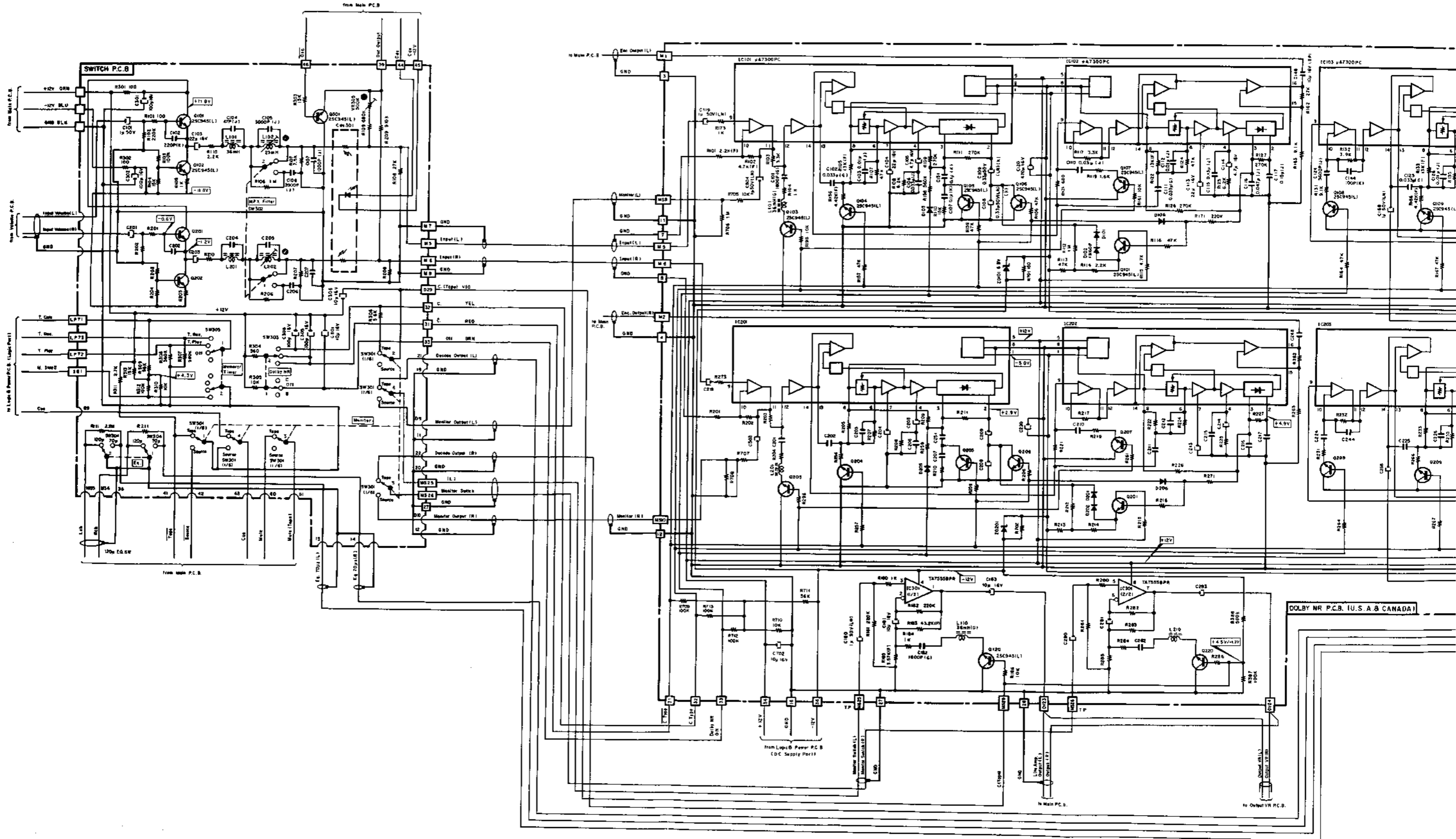

Fig. 13.2.1 U.S.A. & Canada

Notes: 1. Diode is 1SS53, 1S953, or 1S1555 unless otherwise specified.
2. Resistor and capacitor marked with * show typical value.

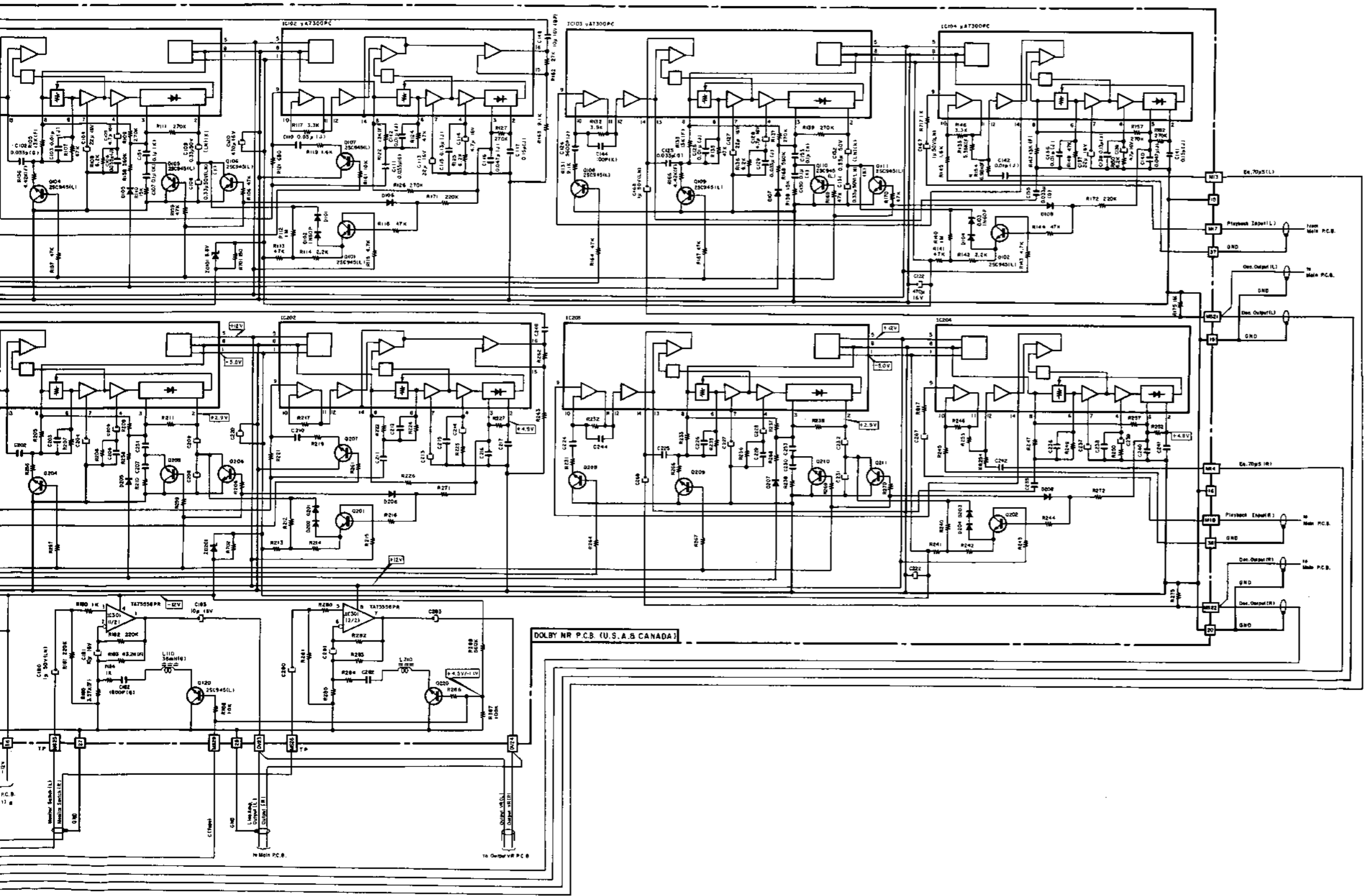

Fig. 13.2.1 U.S.A. & Canada

13.2.2. Dolby NR Section (UK, Australia, 220V Class 2, Others & Japan)

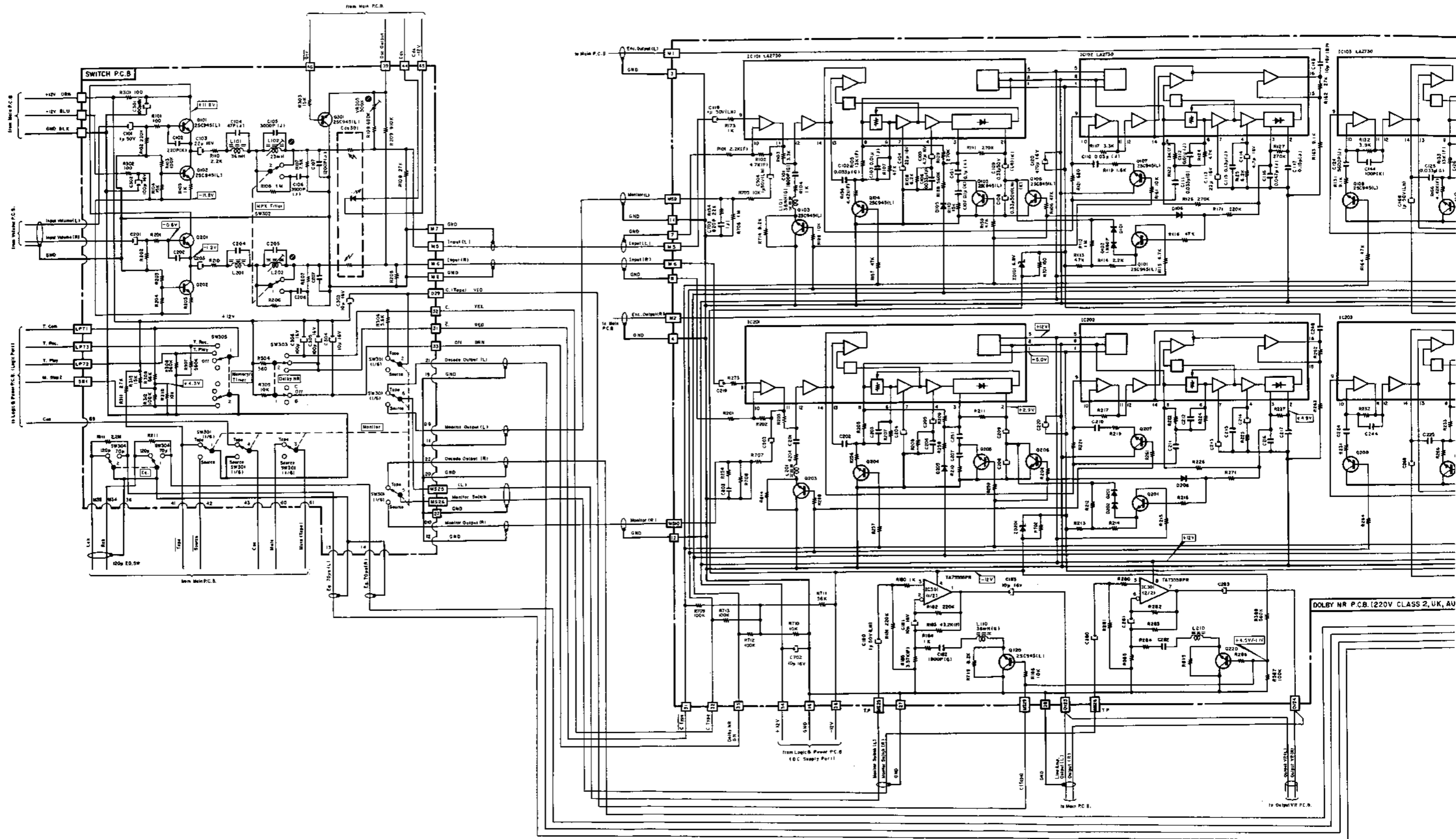

Fig. 13.2.2 UK, Australia, 220V Class 2, Others & Japan

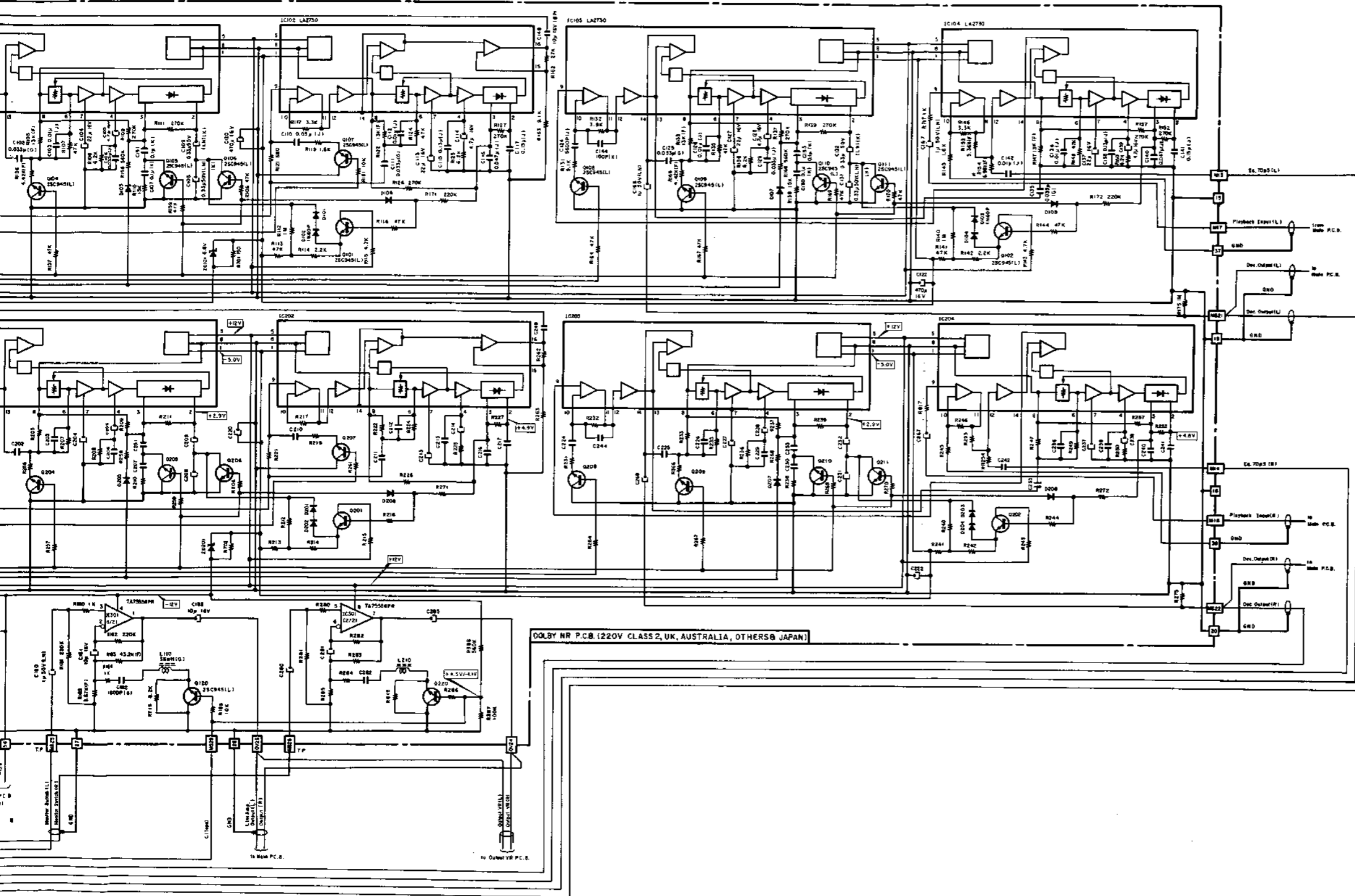

Fig. 13.2.2 UK, Australia, 220V Class 2, Others & Japan

- Notes: 1. Diode is 1SS53, 1S953, or 1S1555 unless otherwise specified.
 2. Resistor and capacitor marked with * show typical value.

13.3. Mechanism Control Section

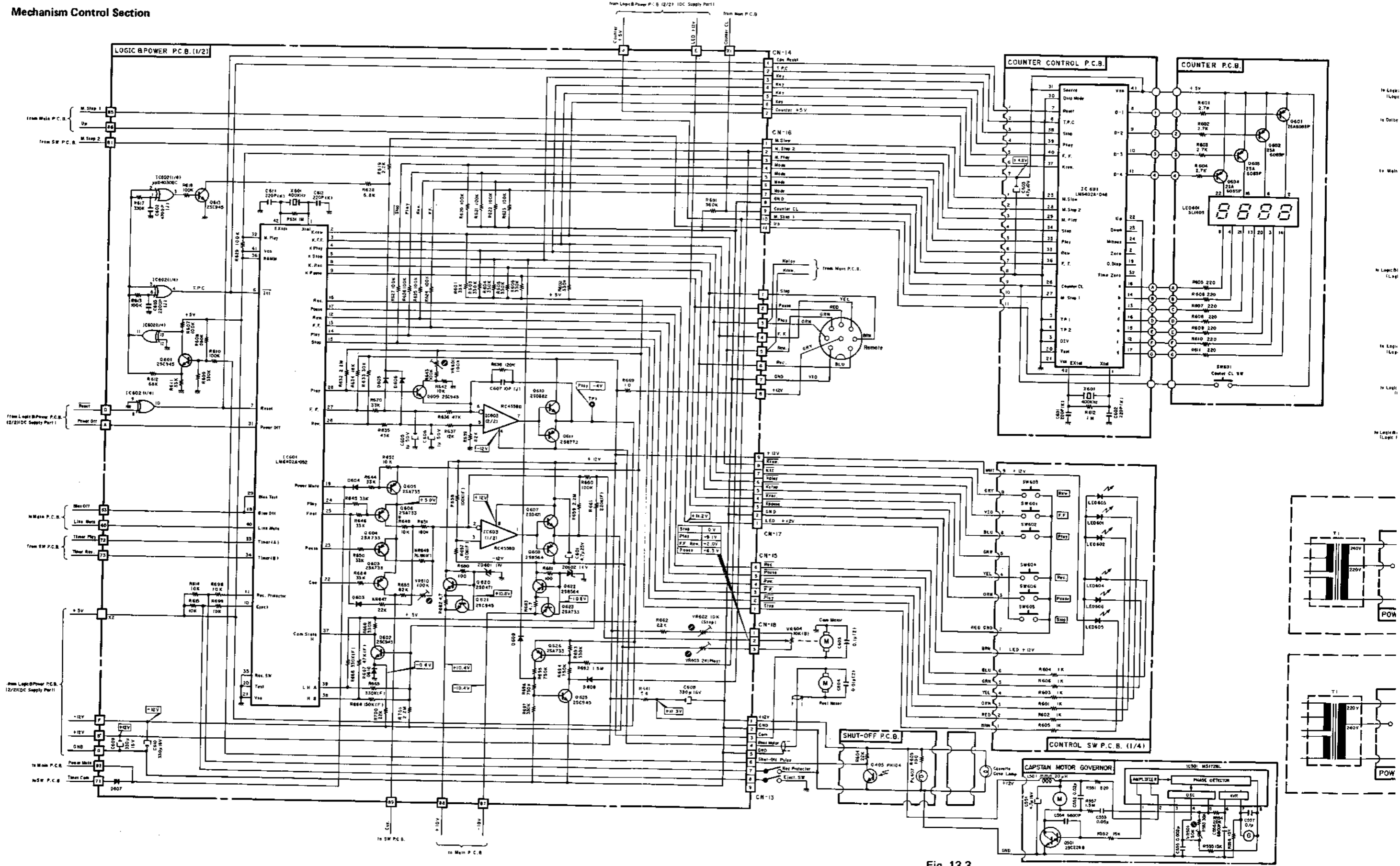

Fig. 13.3

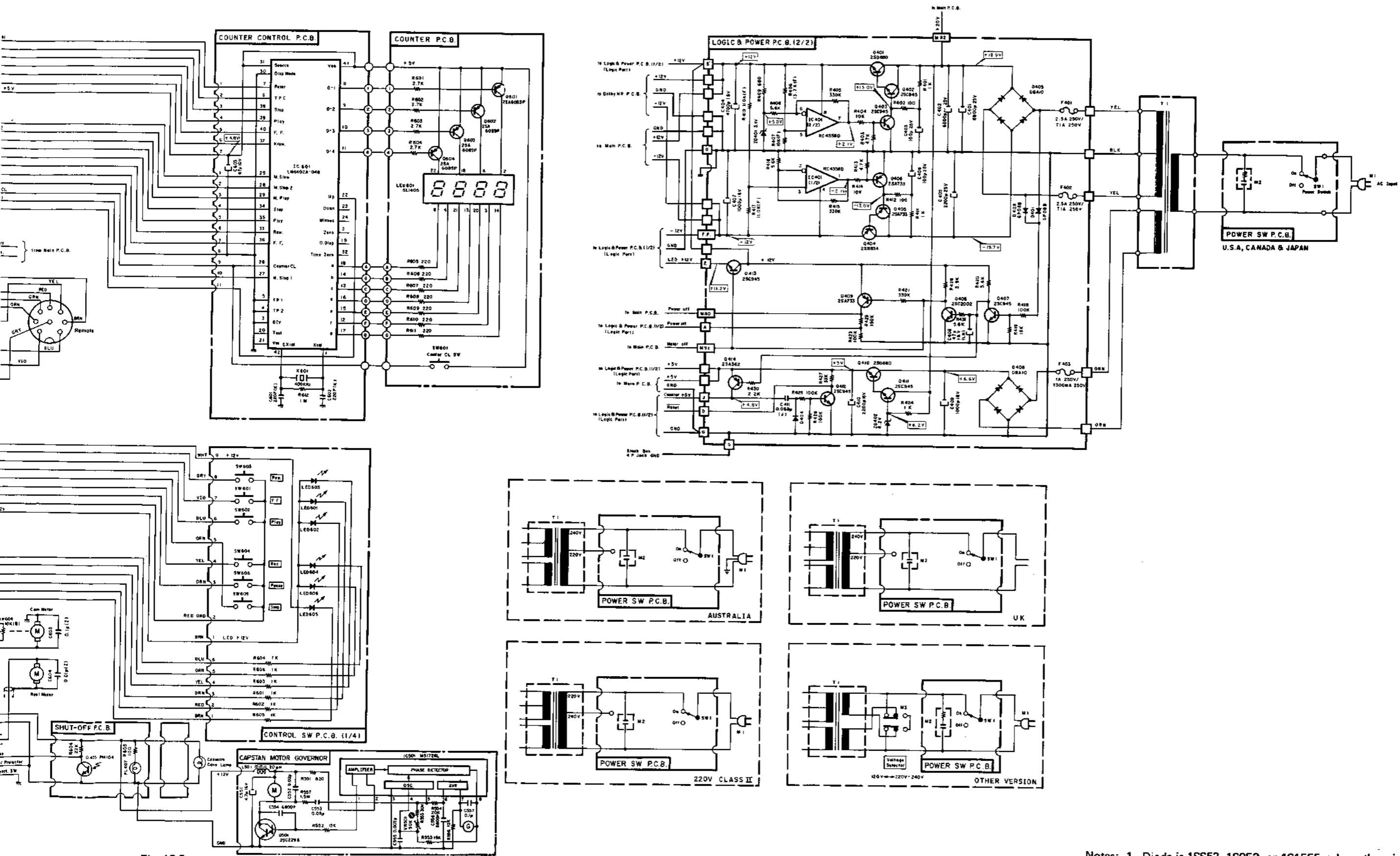

Fig. 13.3

- Notes: 1. Diode is 1S553, 1S953, or 1S1555 unless otherwise specified.
- 2. Resistor and capacitor marked with * show typical value.

13.4. Attention to Servicemen

(1) Parts Replacement

Following parts shall be replaced with the specified ones. Refer to the parts list.

- (a) Power Supply Circuit
Power Cord
Power Transformer: T1
- (b) Power Switch P.C.B. Ass'y
Power Switch: SW1
Spark Killer: M2
- (c) Logic & Power P.C.B. Ass'y
Fuses: F401, 402, 403
Power Transistors: Q401, 404, 408, 410, 414, 607, 608, 610, 611, 620, 622
Diode Bridges: D405, 406
Fail Safe Type Resistors: R641, 669, 680, 681, 682, 683
- (d) Main P.C.B. Ass'y
Power Transistors: Q103, 104, 203, 204, 304
Fail Safe Type Resistors: R122, 222, 301, 302, 305, 306, 309, 310, 314, 315, 372, 373, 967, 968
- (e) Dolby NR P.C.B. Ass'y
Fail Safe Type Resistors: R701, 702
- (f) Shut-off P.C.B. Ass'y
Fail Safe Type Resistor: R605
Lamp: PL407
- (g) Indicator P.C.B. Ass'y
Power Transistors: Q901, 902, 903, 904, 905
Fail Safe Type Resistor: R916
Thermal Fuse: F901
- (h) Switch P.C.B. Ass'y
Fail Safe Type Resistors: R301, 302
- (i) Cassette Case Lamp

(2) Insulation Check

Before returning the repaired ZX-7 to a customer, check to insure that the exposed part is accurately insulated from the AC line by measuring the leakage current or the insulation resistance between them.

13.5. IC Block Diagrams

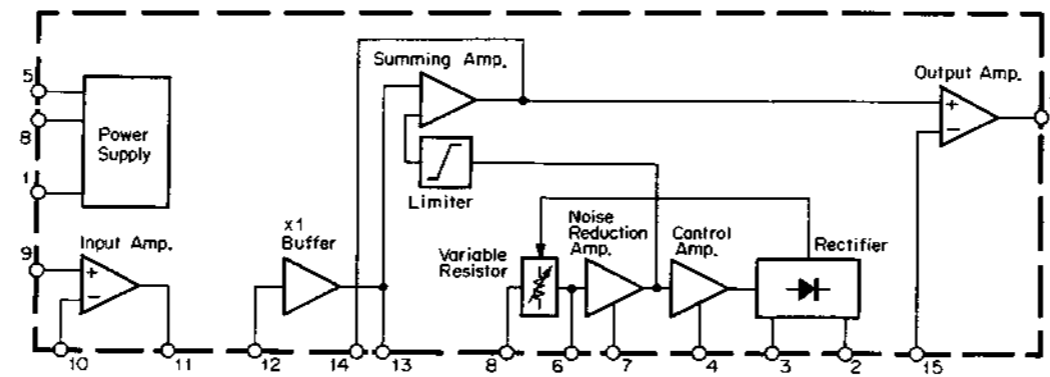

Fig. 13.4 Dolby NR IC $\mu A7300PC$, LA2730

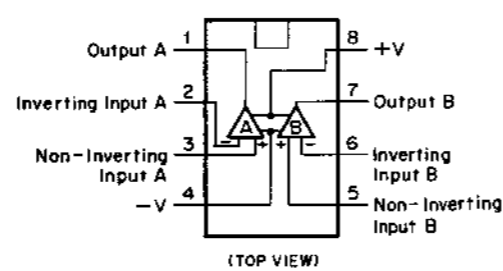

Fig. 13.5 Operational Amp. IC RC4558D, RC4558DD, $\mu PC4556C$, RC4560D, RC4559D, TA75558P-R

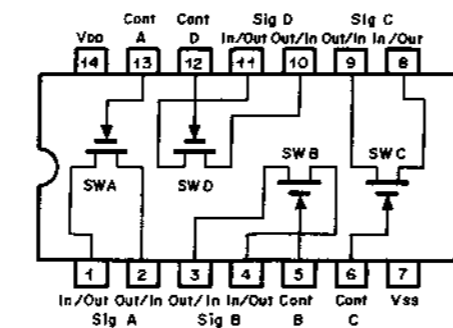

Fig. 13.6 Bilateral Switch C-MOS IC MSM4066RS

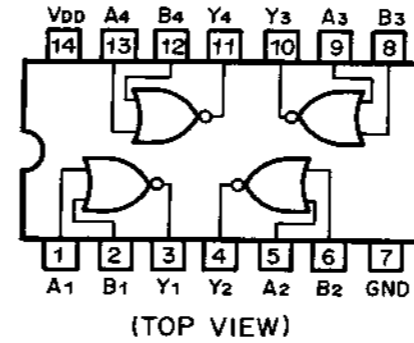

Fig. 13.7 NOR Gate C-MOS IC $\mu PD4001BC$

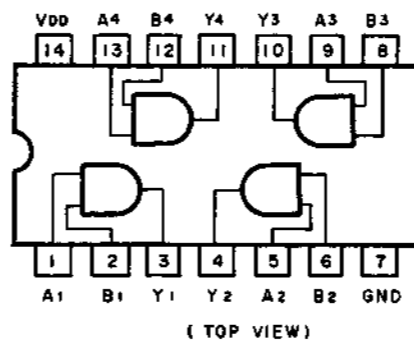

Fig. 13.8 AND Gate C-MOS IC $\mu PD4081BC$

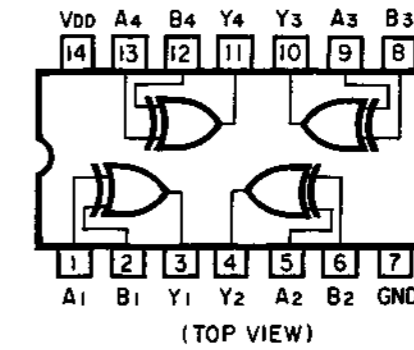

Fig. 13.9 Exclusive OR Gate C-MOS IC $\mu PD4030BC$

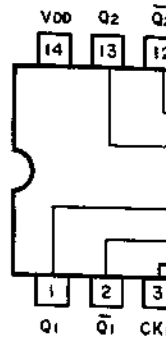

Fig. 13.10 D-Type Flip-Flop C-MOS IC $\mu PD4013BC$

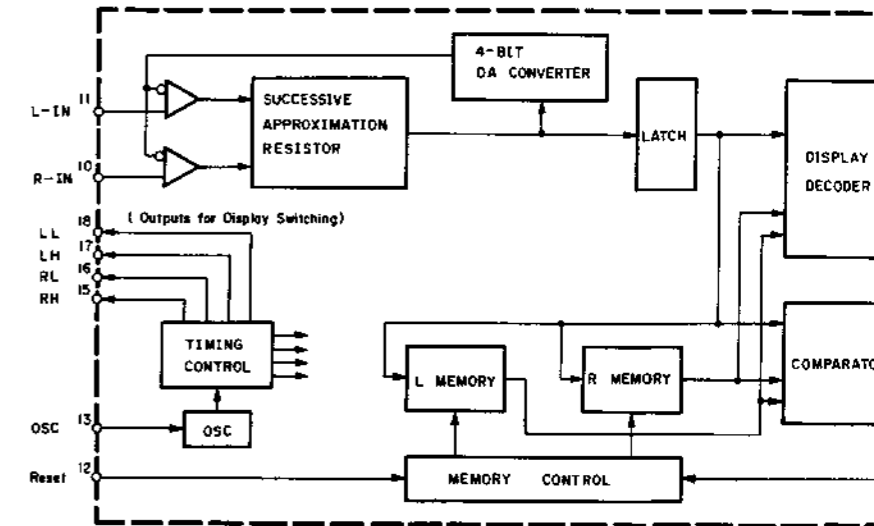

Fig. 13.11 Level Meter Control IC MSL9350RS

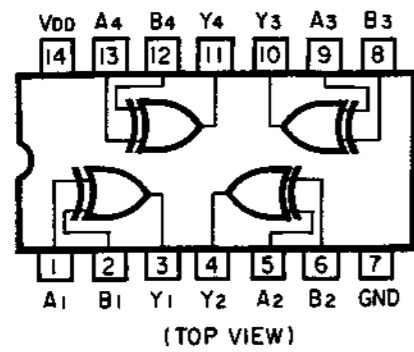
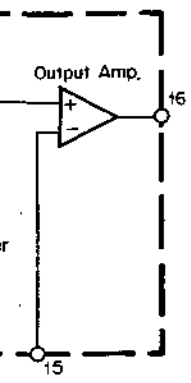

Fig. 13.9 Exclusive OR Gate C-MOS IC μPD4030BC

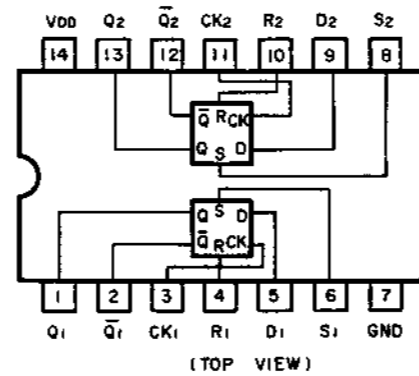
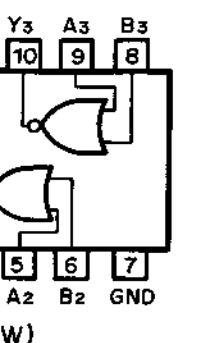
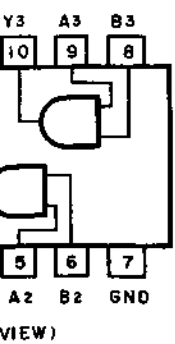

Fig. 13.10 D-Type Flip-Flop C-MOS IC TC4013BP



OS IC μPD4001BC



OS IC μPD4081BC

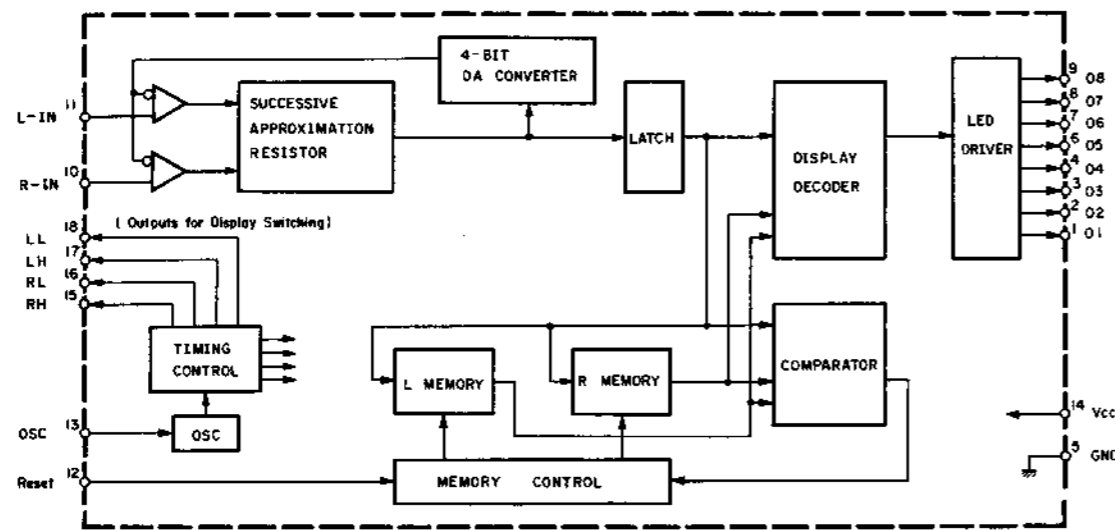
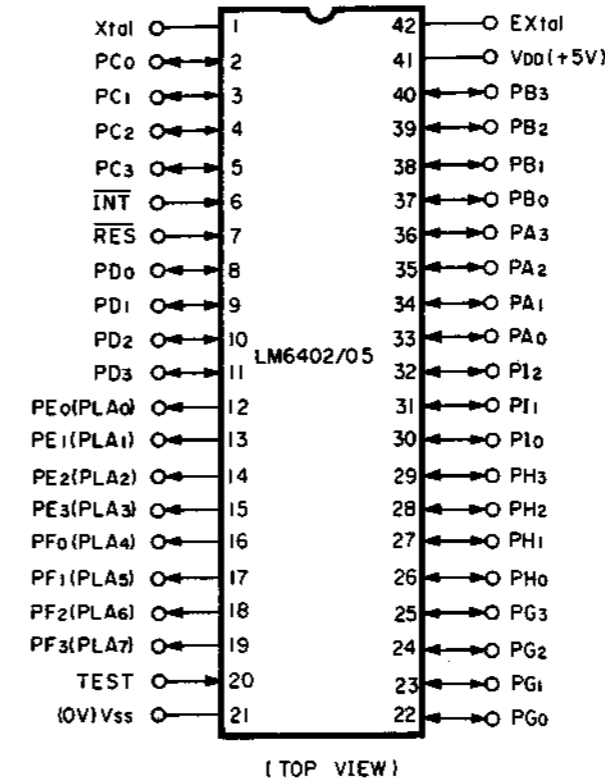
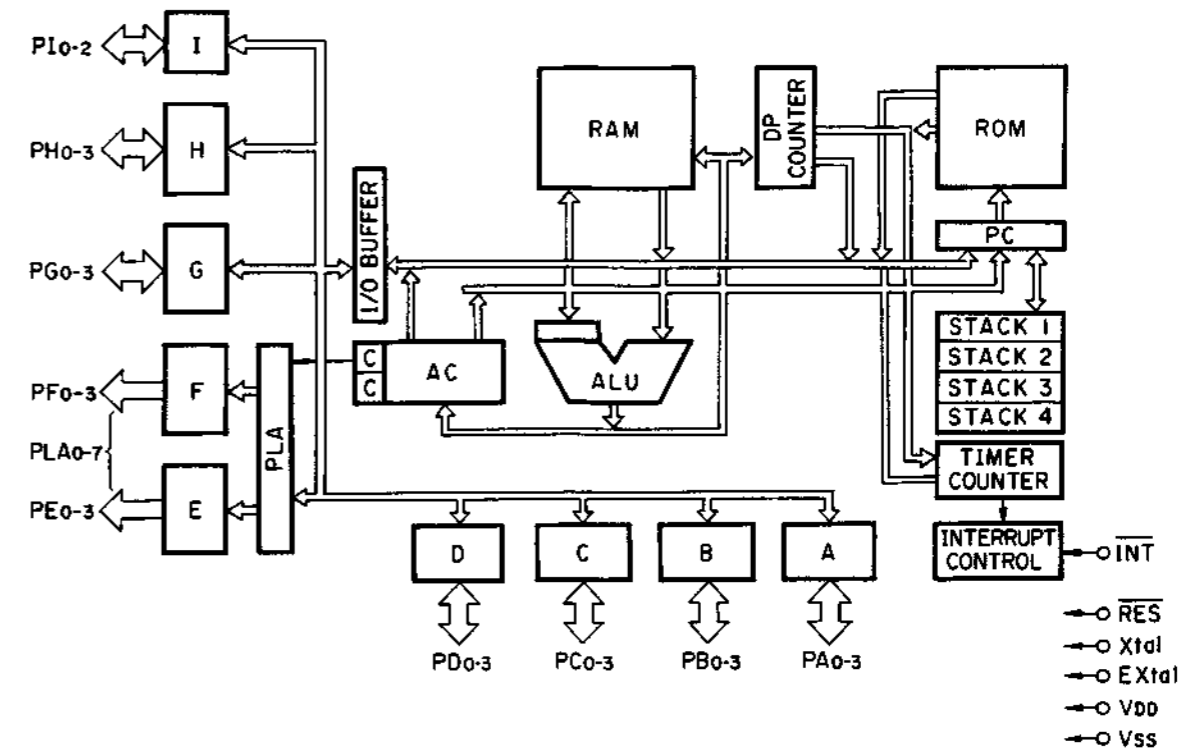

Fig. 13.11 Level Meter Control IC MSL9350RS



- Xtal, EXtal : Crystal input for internal oscillator
- INT : Interrupt
- RES : Reset
- PA0-3 : Bidirectional Port A0-3
- PB0-3 : Bidirectional Port B0-3
- PC0-3 : Bidirectional Port C0-3
- PD0-3 : Bidirectional Port D0-3
- PE0-3 (PLA0-3) : Output Port E0-3(PLA Output 0-3)
- PF0-3 (PLA4-7) : Output Port F0-3(PLA Output 4-7)
- PG0-3 : Bidirectional Port G0-3
- PH0-3 : Bidirectional Port H0-3
- PI0-2 : Bidirectional Port I0-2
- TEST : Test

Fig. 13.12 4-Bit Micro-processor LM6402A-052/048

14. SPECIFICATIONS

Track Configuration	4 Tracks/2-Channel Stereo
Heads	3 (Erase Head x 1, Record Head x1, Playback Head x 1)
Motors (Tape Transport)	PLL Servo Motor (Capstan Drive) x 1 DC Motor (Reel Drive) x 1
Power Source	100, 120, 120/220-240, 220 or 240 V AC; 50/60 Hz (According to country of sale)
Power Consumption	40 W max.
Tape Speed	1-7/8 ips (4.8 cm/sec) $\pm 0.5\%$
Wow and Flutter	Less than 0.08% Wtd peak Less than 0.04% Wtd rms
Frequency Response	20 Hz–21,000 Hz ± 3 dB (recording level –20 dB, ZX Tape) 20 Hz–20,000 Hz ± 3 dB (recording level –20 dB, SX, EXII Tape)
Signal to Noise Ratio	Dolby C-Type NR on <70 μs, ZX Tape> Better than 72 dB (400 Hz, 3% THD, IHF A-Wtd rms) Dolby B-Type NR on <70 μs, ZX Tape> Better than 66 dB (400 Hz, 3% THD, IHF A-Wtd rms)
Total Harmonic Distortion	Less than 0.8% (400 Hz, 0 dB, ZX Tape) Less than 1.0% (400 Hz, 0 dB, SX, EXII Tape)
Erasure	Better than 60 dB (100 Hz, 0 dB)
Separation	Better than 37 dB (1 kHz, 0 dB)
Crosstalk	Better than 60 dB (1 kHz, 0 dB)
Bias Frequency	105 kHz
Input (Line)	50 mV, 70 k ohms
Output (Line)	1 V (400 Hz, 0 dB, Output Level Control at max.), 2.2 k ohms
(Headphones)	45 mW (400 Hz, 0 dB, Output Level Control at max.), 8-ohm load
BlackBox Series DC Output	± 10 V, 125 mA max.
Dimensions	450 (W) x 135 (H) x 300 (D) millimeters 17-3/4 (W) x 5-5/16 (H) x 11-13/16 (D) inches
Approximate Weight	9.5 kg 21 lb.

- Specifications and appearance design are subject to change for further improvement without notice.
- Dolby NR under license from Dolby Laboratories Licensing Corporation.
- The word "DOLBY" and the Double-D-Symbol are trademarks of Dolby Laboratories Licensing Corporation.