



Service Manual

Nakamichi

TA-2

TA-2A

TA-2E

TA-20

High Definition Tuner Amplifier



CONTENTS

1.	General	1
2.	Removal Procedures	3
2. 1.	Top Cover Ass'y and Bottom Cover Ass'y	3
2. 2.	Front Panel	3
2. 3.	Power Switch P.C.B. Ass'y	3
3.	Parts Location for Electrical Adjustment	4
4.	Electrical Adjustments	5
4. 1.	Power Amplifier Section	5
4. 2.	Tuner Section	5
4.2.1.	FM Tuner Section	5
4.2.2.	AM Tuner Section	7
5.	Mechanism Ass'y and Parts List	8
5. 1.	Synthesis	8
5. 2.	Chassis Ass'y (A01)	9
5. 3.	Heat Sink Ass'y (B01)	11
5. 4.	Front Chassis Ass'y (B02)	11
6.	Mounting Diagrams and Parts List	12
6. 1.	AC Outlet P.C.B. Ass'y	12
6. 2.	Power Switch P.C.B. Ass'y	12
6. 3.	Speaker Terminal P.C.B. Ass'y	12
6. 4.	Headphone P.C.B. Ass'y	13
6. 5.	Power LED P.C.B. Ass'y	13
6. 6.	Record Selector P.C.B. Ass'y	13
6. 7.	Loudness P.C.B. Ass'y	13
6. 8.	Motor Volume P.C.B. Ass'y	13
6. 9.	IF Band Switch P.C.B. Ass'y	13
6. 10.	Remote P.C.B. Ass'y	14
6. 11.	Tone Control P.C.B. Ass'y	14
6. 12.	Power Supply P.C.B. Ass'y	15
6. 13.	Control Switch & Display P.C.B. Ass'y	16
6. 14.	Logic P.C.B. Ass'y	18
6. 15.	Main P.C.B. Ass'y	19
7.	Schematic Diagrams	21
7. 1.	IC Block Diagrams	21
7. 2.	Schematic Diagrams	22
7.2.1.	Tuner Section	23
7.2.2.	Amplifier Section	24
8.	Wiring Diagram	25
9.	Block Diagrams	26
9. 1.	Tuner Section	26
9. 2.	Amplifier Section	27
10.	Specifications	28

1. GENERAL

1.1. CAUTIONS/WARNINGS

(1) Product Safety Notice

Parts marked with the symbol  in the schematic diagram have critical characteristics.

Use **ONLY** replacement parts recommended by the manufacturer.

It is recommended that the unit be operated from a suitable DC supply or batteries during initial check-out procedures.

(2) Leakage Current Check/Resistance Check

Before returning the unit to the customer, make sure you make either (1) a leakage current check or (2) a line to chassis resistance check. If the leakage current exceeds 0.5 milliamp, or if the resistance from chassis to either side of the power cord is less than 240 k ohms, the unit is defective.

WARNING — DO NOT return the unit to the customer until the problem is located and corrected.

(3) Lithium Battery Caution

Use **ONLY** replacement parts recommended by the manufacturer. Replacement must be done only by qualified service personnel because of risk for explosion.

WARNING

Litiumbatteri. Explosionsfare ved felaktig hantering. Byte får endast ske av sakkunnig personal enligt servicedokumentationens anvisningar.

ADVARSEL!

Lithiumbatterier. Eksplosionsfare. Udskiftning må kun foretages af en sagkyndig og som beskrevet i servicemanualen.

batterierne kun må udskiftes med batterier af samme fabrikat og type.

1.2. Destination

TA-2: Other & Australia
 TA-2A: U.S.A. & Canada
 TA-2E: Europe
 TA-20: Japan

1.4. Package Ass'y

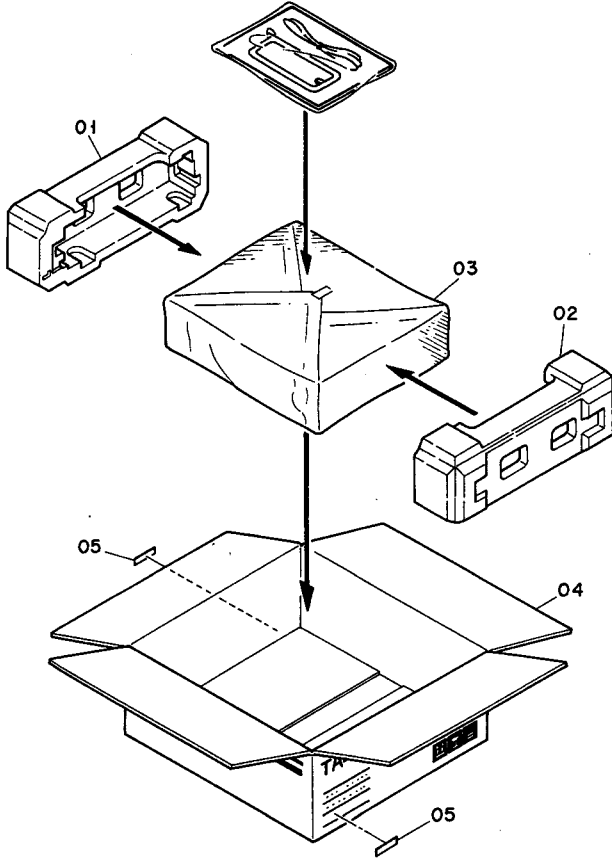

Fig. 1.1

1.3. Voltage Selector

Voltage selector is installed on the rear panel for Other version of the TA-2.
 This voltage selector can select 110, 120, 220, or 240 V at customer's disposal.

1.5. Accessory Ass'y

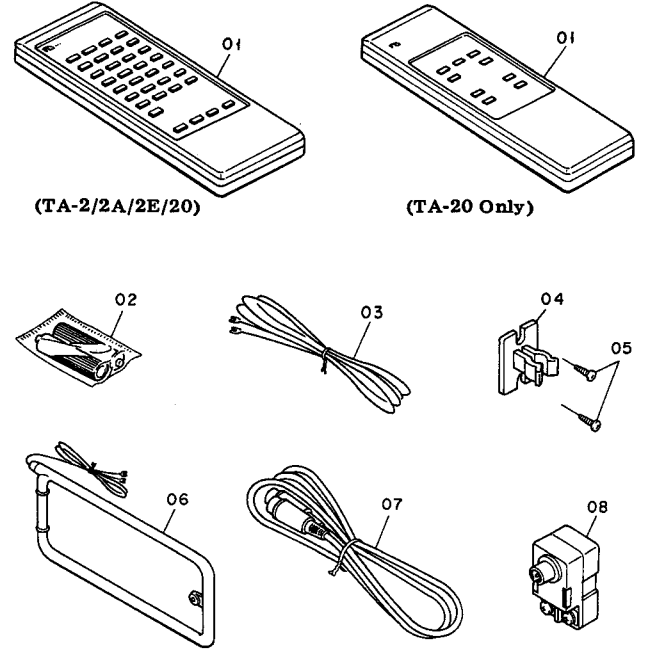

Fig. 1.2

Schematic Ref. No.	Part No.	Description	Q'ty	Schematic Ref. No.	Part No.	Description	Q'ty
		Package Ass'y				Accessory Ass'y	
01	OF04195A	Packing L (TA-2A)	1	01	DA04195A	Remote Control Unit	1
	OF04041B	Packing L (TA-2/2E/20)	1		DA04209A	Remote Control Unit (TA-20)	1
02	OF04196A	Packing R (TA-2A)	1	02	OB90242A	Battery AA Type x 2 (TA-2/2E)	1
	OF04042B	Packing R (TA-2/2E/20)	1		OB90341A	Battery AA Type x 2 (TA-2A)	1
03	OF04199A	Soft Sheet (TA-2A)	1		OB90276A	Battery UM 3x2 (TA-20)	2
	OF03670A	Poly Sheet (TA-2/2E/20)	1	03	OB90320A	Feeder Antenna	1
04	OF04189A	Carton Box (TA-2)	1	04	OB90319A	Loop Antenna Holder	1
	OF04187A	Carton Box (TA-2A)	1	05	OE03496A	Screw 3.1x10 @BLK (For Wood)	1
	OF04190A	Carton Box (TA-2E)	1	06	OB90318A	AM Loop Antenna	1
	OF04188A	Carton Box (TA-20)	1	07	OB83465A	8P DIN Cable (TA-20)	1
05	OM05246A	Serial No. Label (TA-2A)	2	08	OB90208A	Antenna Adapter EP (TA-2E)	1
	OM05279A	Serial No. Label (TA-2/2E/20)	1		OB90194A	Antenna Adapter F (TA-20)	1
-	OM03457A	Voltage Label 240V (TA-2 (Australia))	2	-	OD04810A	Important Notice	1
-	OF04218A	Rear Spacer Packing (TA-2/2E/20)	1	-	OD04836C	Warranty Card (TA-2A)	1
				-	OD04872D	Owner's Manual (English/German/French)	1
				-	OD04875A	Owner's Manual (Japanese)	1
				-	OD04902A	Poly Bag for Set (TA-2A)	1
				-	OD04903A	Poly Bag for Accessory (TA-2A)	1
				-	OD03092B	Poly Bag for Accessory (TA-2/2E/20)	1
				-	OD04212A	Poly Bag for Knob (TA-2/2E/20)	1

2. REMOVAL PROCEDURES

2.1. Top Cover Ass'y and Bottom Cover Ass'y

Refer to Fig. 2.1.

- (1) Loosen screws F01 (5 pcs.) and remove F02 (Top Cover Ass'y).
- (2) Loosen screws F03 (10 pcs.) and remove F04 (Bottom Cover Ass'y).
- (3) Loosen screws F05 (2 pcs.) and remove legs (F06) as required.

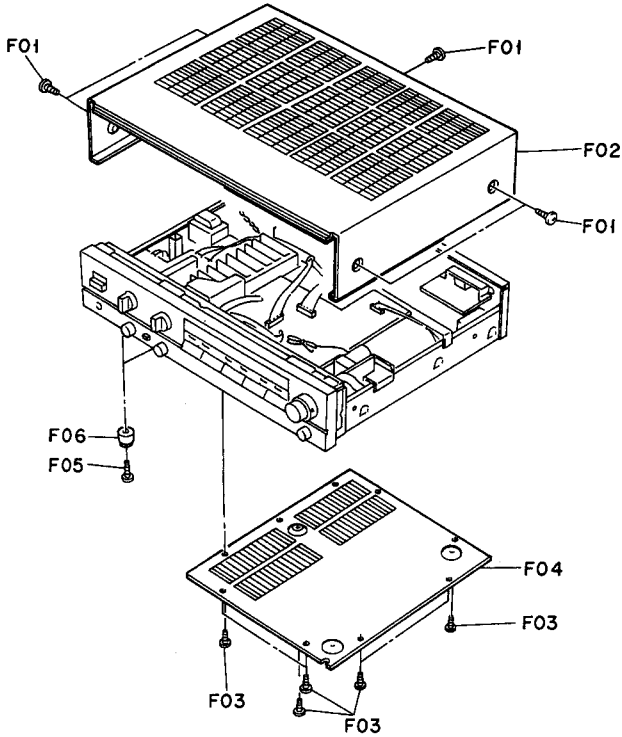

Fig. 2.1

2.2. Front Panel

Refer to Fig. 2.2.

- (1) Remove the Top Cover Ass'y and Bottom Cover Ass'y referring to item 2.1.
- (2) Loosen screws F01 (3 pcs.), F02 (2 pcs.) and F03 (3 pcs.), and remove F04 (Front Panel).

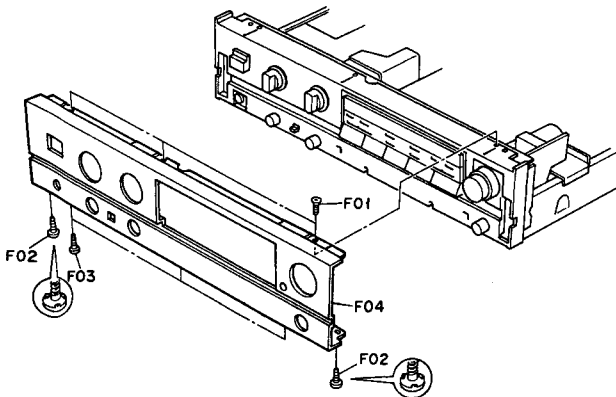

Fig. 2.2

2.3. Power Switch P.C.B. Ass'y

Refer to Figs. 2.3.1 and 2.3.2.

- (1) Remove the Top Cover Ass'y referring to item 2.1.
- (2) Pull out a knob F01, loosen a nut F02, and remove a washer F03.
- (3) Loosen screws F04 (2 pcs.) and remove a button F05. To remove F05, push the Power Switch rearward as shown in Fig. 2.3.2.
- (4) Remove F06 (Power Switch P.C.B. Ass'y).

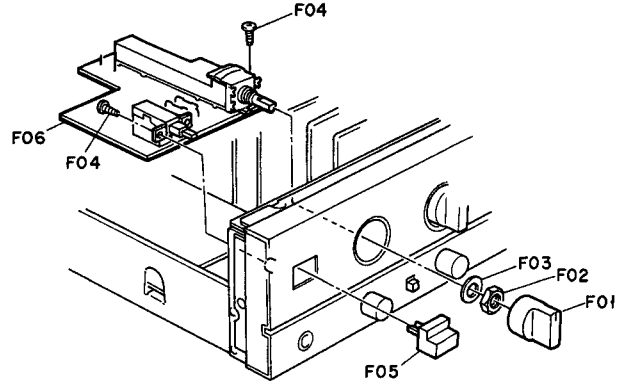

Fig. 2.3.1

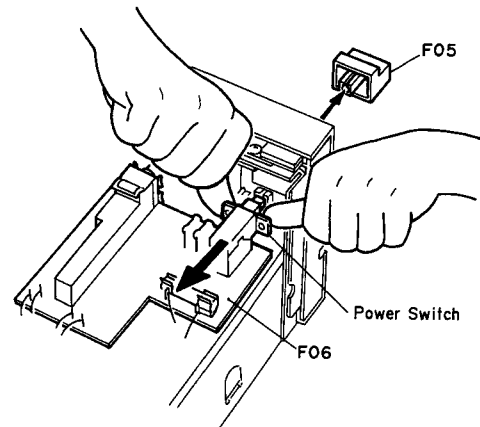

Fig. 2.3.2

3. PARTS LOCATION FOR ELECTRICAL ADJUSTMENT

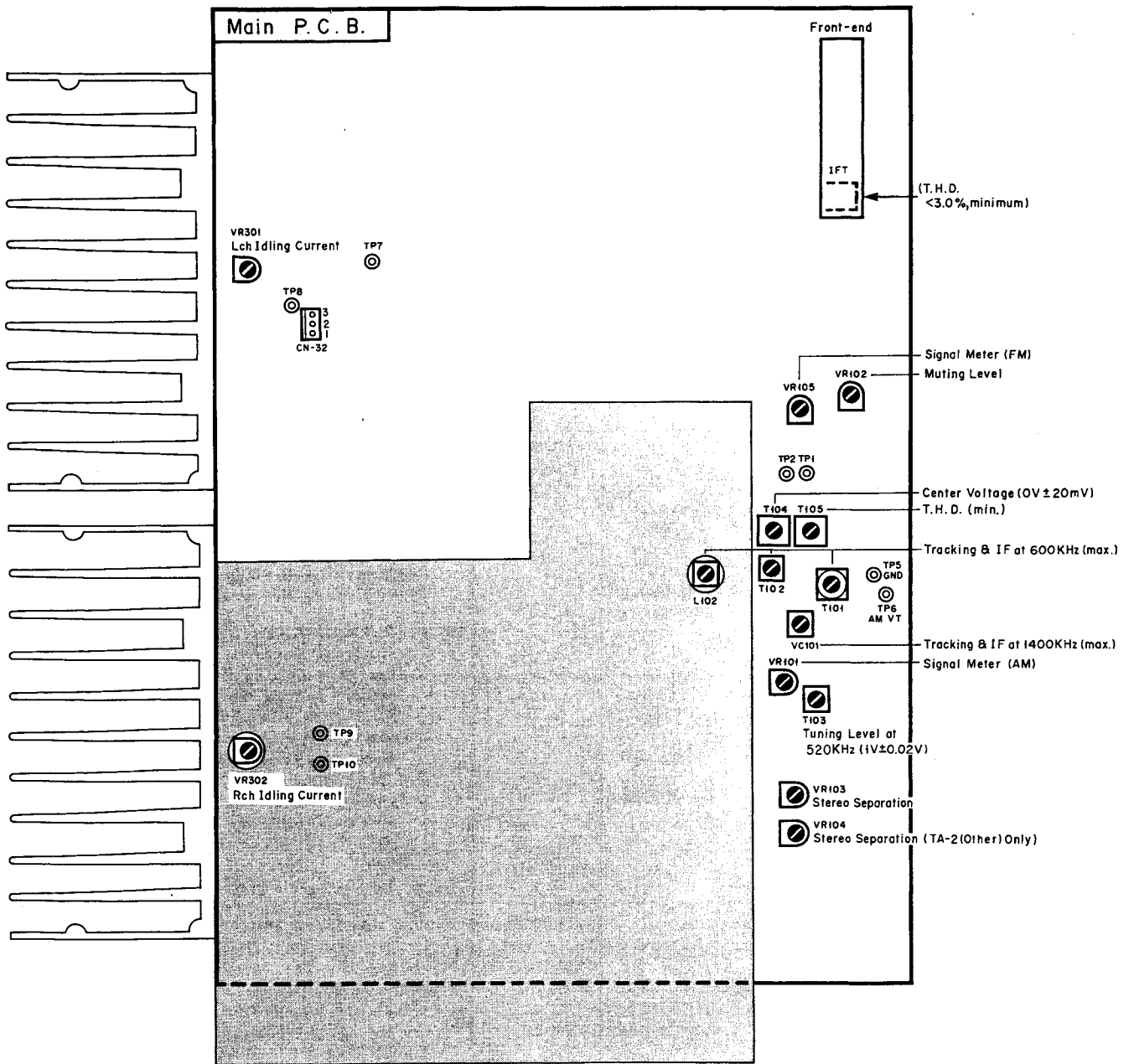

Fig. 3

4. ELECTRICAL ADJUSTMENTS

4.1. Power Amplifier Section

STEP	ITEM	SIGNAL SOURCE	OUTPUT CONNECTION	MODE	ADJUSTMENT	REMARKS
1	Idling Current	None	DC Voltmeter between TP7 & 8 (or CN32-2 & 3) and TP7 & CN32-1 on Main P.C.B.	Input Selector - CD Output Level - Min. Speaker Selector - OFF	Main P.C.B. VR301 VR302	<ol style="list-style-type: none"> 1. Insert shorting plugs into the CD Player Input Jacks. 2. Turn ON the power and allow 3 minutes before adjustment. (Top Cover must be installed in this period of time.) 3. Adjust VR301 (VR302) to obtain $25 \text{ mV} \pm 5 \text{ mV}$ on the DC voltmeter.

4.2. Tuner Section

Note: Adjustment should be made in a shielded room in principle.

4.2.1. FM Tuner Section

STEP	ITEM	OUTPUT CONNECTION	MODE	ADJUSTMENT	REMARKS
1	Preliminary Step	See Fig. 4.1	Tuner Amplifier Input Selector - Tuner Band Selector - FM Tape Monitor - Source Signal Generator Freq. - 98 MHz - 83 MHz (Japan) RF Level - 65 dBf Modulation - See REMARKS		<ol style="list-style-type: none"> 1. Set the Tuner Amplifier as indicated in the MODE. 2. Adjustment and confirmation should be made after tuning in to the set carrier frequency of the Signal Generator. <p>Note: Contents of modulation</p> <ol style="list-style-type: none"> 1. For U.S.A., Canada, Other (Wide) & Japan <ul style="list-style-type: none"> o Stereo Audio: 1 kHz, 91% Pilot: 19 kHz, 9% o Mono Audio: 1 kHz, 100% 2. For Australia, Europe & Other (Narrow) <ul style="list-style-type: none"> o Stereo Audio: 1 kHz, 51% Pilot: 19 kHz, 9% o Mono Audio: 1 kHz, 60%
2	Usable Sensitivity Adjustment	Distortion Meter to Tape Record Output Jacks	Tuner Amplifier Same as above Signal Generator Freq. - 98 MHz - 83 MHz (Japan) RF Level - 13.5 dBf Modulation - Mono	Main P.C.B. Front-end IFT	<ol style="list-style-type: none"> 1. Set the Tuner Amplifier to Manual mode by pressing the Tuning Mode button. 2. Adjust the IFT to obtain minimum distortion (total harmonic distortion (THD): 3% or less). 3. Set the frequency of the Signal Generator to 90 MHz/106 MHz and check that the THD is 3% or less.

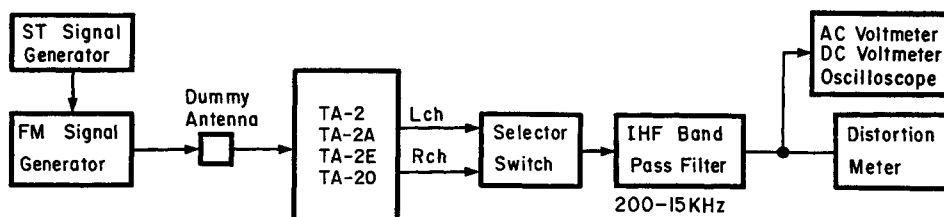

Fig. 4.1 FM Measuring Connection

STEP	ITEM	OUTPUT CONNECTION	MODE	ADJUSTMENT	REMARKS
3	Center Voltage and THD Adjustment	DC Voltmeter between TP1 & TP2 on Main P.C.B. and Distortion Meter to Tape Record Output Jacks	Tuner Amplifier Same as above Signal Generator Freq. - 98 MHz - 83 MHz (Japan) RF Level - 65 dBf Modulation - Mono	Main P.C.B. T104 T105	1. Set the Tuner Amplifier to Manual mode. 2. Adjust T104 so that the reading on the DC voltmeter is 0 V \pm 20 mV. 3. Adjust T105 to obtain minimum distortion (THD: 0.05% or less). Repeat 2 and 3, if necessary.
4	Muting Level Adjustment	Oscilloscope to Tape Record Output Jacks	Tuner Amplifier Same as above Signal Generator Freq. - 98 MHz - 83 MHz (Japan) RF Level - 30 dBf Modulation - Stereo	Main P.C.B. VR102	1. Set the Tuner Amplifier to Auto mode. 2. Rotate VR102 fully counterclockwise. Then, return it clockwise gradually until a waveform appears on the oscilloscope. 3. Decrease the RF level of the Signal Generator until the waveform on the oscilloscope disappears. Then increase the RF level gradually until a waveform appears again. At this point, check that the RF level of the Signal Generator is 30 dBf \pm 6 dB.
5	Signal Strength Meter Level Adjustment	None	Tuner Amplifier Same as above Signal Generator Freq. - 98 MHz - 83 MHz (Japan) RF Level - 56 dBf Modulation - Stereo	Main P.C.B. VR105	1. Set the Tuner Amplifier to Auto mode. 2. Adjust VR105 so that all segments (1 - 5) of the signal strength meter light up. 3. Decrease the RF level of the Signal Generator to distinguish the segment 5. Next, increase it gradually so that the segment 5 starts illuminating. At this point, check that the RF level of the Signal Generator is 57 dBf \pm 4 dB.
6	Stereo Separation Adjustment	AC Voltmeter to Tape Record Output Jacks	Tuner Amplifier Same as above Signal Generator Freq. - 98 MHz - 83 MHz (Japan) RF Level - 65 dBf Modulation - L or R only	Main P.C.B. VR103 IF Band Switch P.C.B. VR104 (Other only)	For U.S.A., Canada, Europe & Australia versions: 1. Set the Tuner Amplifier to Auto mode. 2. Apply modulation to only L channel. 3. Adjust VR103 to obtain minimum reading on the AC voltmeter at the R channel output jack. 4. Apply modulation to only R channel. 5. Check that the reading on the AC voltmeter at the L channel output jack is within \pm 1 dB with respect to the reading in 3. If not, repeat 2 through 4. For Other version: 1. Set the switches on the rear panel as follows: Freq. Step FM/AM - 100 kHz/10 kHz IF Band - Wide 2. Apply the same procedures as above. 3. Set the switches as follows: Freq. step FM/AM - 50 kHz/9 kHz IF Band - Narrow 4. Apply the same procedures as mentioned above. Adjust VR104 instead of VR103.

4.2.2. AM Tuner Section

Note: Frequencies for Australia, Europe & Other (Narrow) are indicated in parentheses.

STEP	ITEM	OUTPUT CONNECTION	MODE	ADJUSTMENT	REMARKS
1	Tuning Level Adjustment	DC Voltmeter between TP6 and TP5 (GND) on Main P.C.B.	Tuner Amplifier Input Selector - Tuner Band Selector - AM Tape Monitor - Source Signal Generator Freq. - 520 (522) kHz/ 1710 (1611) kHz	Main P.C.B. T103	<ol style="list-style-type: none"> 1. Set the frequency of the Signal Generator to 520 kHz (522 kHz) and make tuning. 2. Adjust T103 to obtain 1 V \pm0.02 V on the DC voltmeter. 3. Change the frequency to 1710 kHz (1611 kHz) and make tuning. Check whether the DC voltmeter reads 7.5 V to 8 V.
2	Tracking and IF Adjustment	AC Voltmeter to Tape Record Output Jacks	Tuner Amplifier Same as above Signal Generator Freq. - 600 (603) kHz/ 1400 (1404) kHz RF Level - 82 dB μ /m Modulation - 400 Hz 30%	Main P.C.B. T101 T102 L102 VC101	<ol style="list-style-type: none"> 1. Set the measurement instruments as shown in Fig. 4.2. Set the distance between the AM Loop Antenna of the TA-2/2A/2E/20 and a test loop to 60 cm. To obtain 56 dBμ/m at the AM Loop Antenna, set the RF level output of the AM Signal Generator to 82 dBμ/m as loss is 26 dBμ/m in this setting. 2. Set the frequency of the Signal Generator to 600 kHz (603 kHz) and make tuning. 3. Adjust T101 to obtain maximum reading on the AC voltmeter. 4. Adjust T102 to obtain maximum reading on the AC voltmeter. 5. Adjust L102 to obtain maximum reading on the AC voltmeter. 6. Set the frequency to 1400 kHz (1404 kHz) and make tuning. 7. Adjust VC101 to obtain maximum reading on the AC voltmeter. 8. Repeat 2 through 7 once.
3	Signal Strength Meter Level Adjustment	None	Tuner Amplifier Same as above Signal Generator Freq. - 1000 (999) kHz RF Level - 106 dB μ /m	Main P.C.B. VR101	<ol style="list-style-type: none"> 1. With the same setting as in Step 2, set the RF level output of the AM Signal Generator to 106 dBμ/m in order to obtain 80 dBμ/m at the AM Loop Antenna. 2. Adjust VR101 so that the segment 5 of the signal strength meter starts illuminating. <p>Note: Before adjustment, select AM mode and wait for more than three minutes.</p>

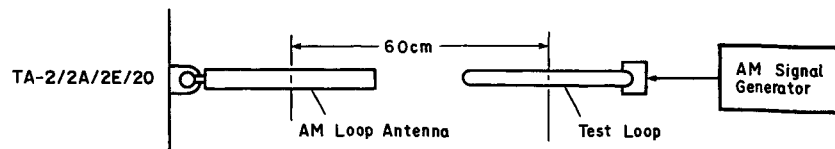

Fig. 4.2

5. MECHANISM ASS'Y AND PARTS LIST

5.1. Synthesis

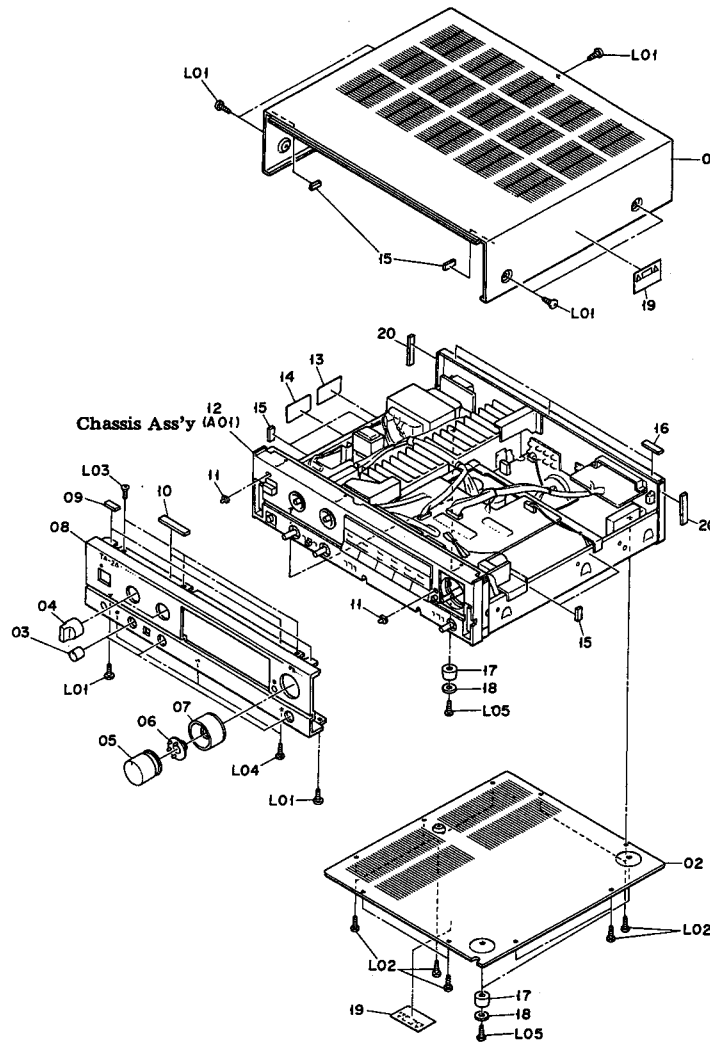

Fig. 5.1

Schematic Ref. No.	Part No.	Description	Qty	Schematic Ref. No.	Part No.	Description	Qty
5.1. Synthesis				19	OM04377B	Caution Label (TA-2A)	2
				20	OJ05850A	Top Cover Cushion	2
				L01	OE03433A	BT3x6 @ Binding Projected (Black Chromate)	7
01	OH05429A	Top Cover (TA-2A)	1	L02	OE00868A	BT3x8 @ Binding	10
	OH05520A	Top Cover (TA-2/2E/20)	1	L03	OE03054A	BT3x8 @ Countersunk	3
02	OJ05727A	Bottom Cover	1	L04	OE00921A	BT3x8 @ Binding (Black Chromate)	3
03	OH05318A	Tone Knob	3	L05	OE00888A	BT3x12 @ Binding	4
04	OH05321A	Selector Knob	2	—	OM04430A	Pass Label (TA-2/2E/20)	1
05	HA05366A	Volume Knob Ass'y	1	—	OM05172A	Pass Label (TA-2A)	1
06	OJ05717A	LED Base	1	—	OM05295A	Fuse Label 2A 250V (TA-2 (Australia)/2E)	1
07	HA05538A	Balance/Volume Ring Ass'y	1	—	OB90288A	Fuse T500mA 250V [F401] (TA-2 (Australia)/2E)	1
08	OH05400A	Front Panel (TA-2)	1	—	OB90289A	Fuse T1A 250V [F404] (TA-2 (Other))	1
	OH05398A	Front Panel (TA-2A)	1	—	OB90345A	Fuse T0.5A 250V [F401] (TA-2 (Other))	1
	OH05399A	Front Panel (TA-2E)	1	—	OB90346A	Fuse T4A 250V [F403] (TA-2 (Other))	1
	OH05401A	Front Panel (TA-20)	1	—	OB90349A	Fuse T2A 250V [F403] (TA-2 (Australia)/2E)	1
09	OJ05453A	Top Cover Sheet F	2	—	OB90351A	Fuse 4A 250V [F403] (TA-20)	1
10	OJ05754A	Top Cover Sheet FB	2	—	OB90353A	Fuse 500mA 250V [F401] (TA-20)	1
11	OH05103A	LED Lens B	2				
12	—	Chassis Ass'y	1				
13	OM05288A	Fuse Caution Label T4A (TA-2A)	1				
14	OM05289A	Fuse Caution Label T500mA (TA-2A)	1				
15	OJ05741A	Top Cover Spacer	8				
16	OJ05740A	Top Cover Sheet R	3				
17	OJ05420A	Leg N (TA-2/2A/2E)	4				
	OH05182A	Leg Ring (TA-20)	4				
	OH05183A	Leg (TA-20)	4				
18	OJ05461A	Leg Felt N (TA-2/2A/2E)	4				
	OJ05428A	Leg Felt (TA-20)	4				

Schematic Ref. No.	Part No.	Description	Qty	Schematic Ref. No.	Part No.	Description	Qty
5.2. Chassis Ass'y (A01)							
A01	—	Chassis Ass'y	1	37	OH05410A	Rear Panel (TA-2E)	1
01	OB50124A	Power Transformer (TA-2 (Australia)/2E)	1	38	OH05407A	Rear Panel (TA-20)	1
	OB50126A	Power Transformer (TA-2 (Other))	1		OB90280A	Cord Bushing	1
	OB50123A	Power Transformer (TA-2A)	1		OB80148A	AC Power Cord (TA-2 (Australia))	1
	OB50127A	Power Transformer (TA-20)	1		OB80199A	AC Power Cord SPT-2 (TA-2 (Other)/2A)	1
02	BA07393A	Power Supply P.C.B. Ass'y (TA-2 (Australia)/2E)	1	39	OB80893U	AC Power Cord (TA-2E)	1
	BA07391A	Power Supply P.C.B. Ass'y (TA-2 (Other))	1	40	OB90274A	AC Power Cord (TA-20)	1
	BA07389A	Power Supply P.C.B. Ass'y (TA-2A)	1	41	OJ05742A	P.C.B. Spacer	1
	BA07390A	Power Supply P.C.B. Ass'y (TA-20)	1	42	OJ05736A	Remote P.C.B. Holder	1
03	OJ05732A	Side Chassis R	1	43	BA07377A	Remote P.C.B. Ass'y	1
04	OJ05738A	Spacer Support A	2	44	OJ05710A	Shorting Pin	2
05	OJ05739A	Spacer Support B	1	45	JA04383A	Ground Terminal Ass'y	1
06	OB80211A	Glass Tube 150	1	46	OB90316A	AM Antenna Holder	1
07	OB80212A	Glass Tube 100	1		OB08515A	Insu-Lock 100	20
08	—	Heat Sink Ass'y	1	L01	BA07383A	IF Band Switch P.C.B. Ass'y (TA-2 (Other))	1
09	OJ05729A	P.C.B. Holder B	1	L02	OB70049A	Voltage Selector Switch (TA-2 (Other))	1
10	BA07562A	Logic P.C.B. Ass'y (TA-2 (Other))	1	L03	OB90399A	Lithium Battery 3V CR2430 [B501]	1
	BA07376A	Logic P.C.B. Ass'y (TA-2 (Australia)/2E)	1	L04	OE00929A	M4x8 @ Binding	4
	BA07386A	Logic P.C.B. Ass'y (TA-2A)	1	L05	OE00031A	Washer 4x8x0.5	4
	BA07545A	Logic P.C.B. Ass'y (TA-20)	1	L06	OE03432A	BT3x6 @ Tapping (Black Chromate)	8
11	OJ05735A	Logic P.C.B. Holder	1	L07	OE00868A	BT3x8 @ Binding	33
12	OJ05728A	P.C.B. Holder A	1	L08	OE03433A	BT3x6 @ Binding Projected (Black Chromate)	2
13	OJ05670A	Earth Plate (TA-2A)	2	L09	OE00921A	BT3x8 @ Binding (Black Chromate)	20
14	BA07370A	Main P.C.B. Ass'y (TA-2 (Australia))	1	L10	OE00766A	M3x8 @ Binding	3
	BA07369A	Main P.C.B. Ass'y (TA-2 (Other))	1	L11	OE03382A	Nut Hex. M7	4
	BA07367A	Main P.C.B. Ass'y (TA-2A)	1	L12	OE03383A	Washer M7	4
	BA07371A	Main P.C.B. Ass'y (TA-2E)	1	L13	OE03375A	Nut Hex. M9	2
	BA07368A	Main P.C.B. Ass'y (TA-20)	1	L14	OE03376A	Washer M9	2
15	OH05325A	Power Button	1	L15	OJ05673A	Nut 70	1
16	—	Front Chassis Ass'y	1	L16	OE00071A	Washer Fiber 3mm	1
17	BA07382A	Power LED P.C.B. Ass'y	1	L17	OJ05427A	Mounting Plate	1
18	BA07612A	Power Switch P.C.B. Ass'y (TA-2 (Other))	1		OE03278A	BT3x8 @ Tapping (Black Chromate)	2
	BA07374A	Power Switch P.C.B. Ass'y (TA-2 (Australia)/2E)	1		OE03202A	M2.6x3 @ Binding (Black Chromate) (TA-2 (Other))	4
	BA07372A	Power Switch P.C.B. Ass'y (TA-2A)	1		OM05270A	Lithium Caution Label (TA-2E)	1
	BA07373A	Power Switch P.C.B. Ass'y (TA-20)	1		OB09290A	Ceramic Capacitor 0.01μ 50V Z (TA-2E)	2
19	BA07381A	Headphone P.C.B. Ass'y	1		OB09292A	Ceramic Capacitor 0.1μ 50V Z (TA-2E)	1
20	OJ05612A	Volume Ground Plate A	1		OB90400A	Fiber Washer 6mm (TA-2/2E/20)	1
21	BA07385A	Record Selector P.C.B. Ass'y	1		OE00907A	ST4x8 @ Binding (TA-2/2E/20)	4
22	BA07384A	Tone Control P.C.B. Ass'y (TA-2/2A/20)	1		OE00174A	Earth Lug B-4 (TA-2E)	3
	BA07591A	Tone Control P.C.B. Ass'y (TA-2E)	1				
23	BA07388A	Control Switch & Display P.C.B. Ass'y (TA-2E)	1				
	BA07387A	Control Switch & Display P.C.B. Ass'y (TA-2/2A)	1				
	BA07546A	Control Switch & Display P.C.B. Ass'y (TA-20)	1				
24	OJ05703A	Lug Terminal 7	2				
25	BA07380A	Loudness P.C.B. Ass'y	1				
26	OJ05737A	Front Stud	2				
27	OJ05730A	Front Chassis	1				
28	OJ05731A	Chassis L	1				
29	OJ05733A	Volume Holder	1				
30	BA07379A	Motor Volume P.C.B. Ass'y	1				
31	OJ05726A	Front Holder	1				
32	BA07614A	Speaker Terminal P.C.B. Ass'y (TA-2/20)	1				
	BA07378A	Speaker Terminal P.C.B. Ass'y (TA-2A)	1				
	BA07392A	Speaker Terminal P.C.B. Ass'y (TA-2E)	1				
33	OJ05753A	Damping Sheet	1				
34	BA07544A	AC Outlet P.C.B. Ass'y (TA-2 (Other)/20)	1				
	BA07375A	AC Outlet P.C.B. Ass'y (TA-2A)	1				
35	OB81988A	AC Outlet (TA-2 (Australia))	1				
	OB81928A	AC Outlet AC-T05LB57 (TA-2 (Other)/2A)	1				
	OB81987A	AC Outlet (TA-2E)	1				
	OB81986A	AC Outlet 2P (TA-20)	1				
36	OH05409A	Rear Panel (TA-2 (Australia))	1				
	OH05408A	Rear Panel (TA-2 (Other))	1				
	OH05406A	Rear Panel (TA-2A)	1				

5.3. Heat Sink Ass'y (B01)

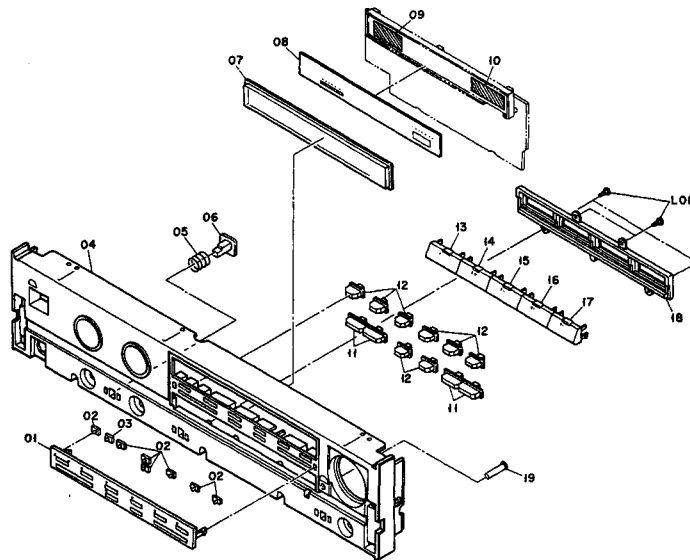

Fig. 5.3

5.4. Front Chassis Ass'y (B02)

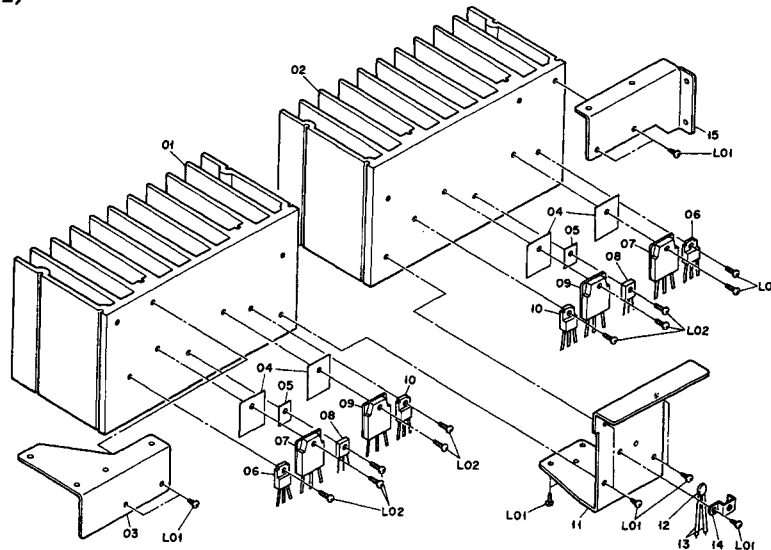

Fig. 5.4

Schematic Ref. No.	Part No.	Description	Q'ty	Schematic Ref. No.	Part No.	Description	Q'ty
5.3. Heat Sink Ass'y (B01)				5.4. Front Chassis Ass'y (B02)			
B01	—	Heat Sink Ass'y	1	B02	—	Front Chassis Ass'y	1
01	OJ05721A	Heat Sink A	1	01	OH05432A	Memory Plate	1
02	OJ05722A	Heat Sink B	1	02	OH05426A	Preset Lens A	7
03	OJ05718A	Heat Sink Holder F	1	03	OH05427A	Preset Lens B	1
04	OJ05671A	Insulator SIL 3P	4	04	OH05431A	Front Chassis	1
05	OJ05672A	Insulator SIL 220	2	05	OJ05406A	Push Spring	1
06	OB10120A	Transistor 2SB1016 (O)	2	06	OH05322A	Push Button	1
07	OB10179A	Transistor 2SC3855 (O)	2	07	OH05326A	Display Lens	1
08	OB06303A	Transistor 2SB772 (Q,P)	2	08	OH05430A	Display Overlay 1089	1
09	OB10177A	Transistor 2SA1491 (O)	2	09	OJ05708A	Diffuser Sheet A	1
10	OB10121A	Transistor 2SD1407 (O)	2	10	OJ05709A	Diffuser Sheet B	1
11	OJ05725A	Joint Holder	1	11	OH05324A	Up/Down Button	4
12	OB19607A	Thermistor 50KD-5	1	12	OH05323A	Preset Button	8
13	OB80209A	Glass Tube 16	2	13	HA05541A	Phono Button Ass'y	1
14	OJ05615A	TH Holder	1	14	HA05542A	CD Button Ass'y	1
15	OJ05719A	Heat Sink Holder R	1	15	HA05543A	Tuner Button Ass'y	1
L01	OE00868A	BT3x8 @ Binding	11	16	HA05544A	Video Button Ass'y	1
L02	OE00986A	M3x10 @ Binding	10	17	HA05545A	Tape Button Ass'y	1
				18	OJ05711A	Button Base	1
				19	OH05438A	Mute Knob	1
				L01	OE00868A	BT3x8 @ Binding	4

6. MOUNTING DIAGRAMS AND PARTS LIST

- Notes: 1. Mounting diagram shows a dip side view of the printed circuit board.
 2. Diode is 1SS53, 1S1555, 1SS176 or 1N4148 unless otherwise specified.
 3. Following transistors are interchangeable with each other.
 a. 2SA733, 2SA608SP, 2SA1048, 2SA1175
 b. 2SC945, 2SC536SP, 2SC2458, 2SC2785
 4. Abbreviation for part name:
 TR — Transistor, SiD — Silicon Diode, ZD — Zener Diode, Varicap — Variable Capacitance Diode
 RK — Carbon Resistor, RM — Metal Film Resistor, RF — Fail Safe Type Resistor
 CE — Electrolytic Capacitor, CML — Mylar Capacitor, CC — Ceramic Capacitor, CPP — PP Capacitor,
 CMM — Metalized Mylar Capacitor, CSP — Polystyrene Capacitor, C — Mica Capacitor

6.1. AC Outlet P.C.B. Ass'y

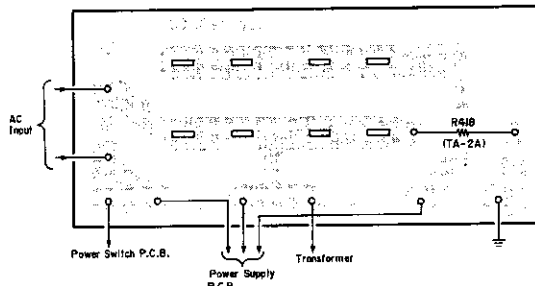

Fig. 6.1

6.2. Power Switch P.C.B. Ass'y

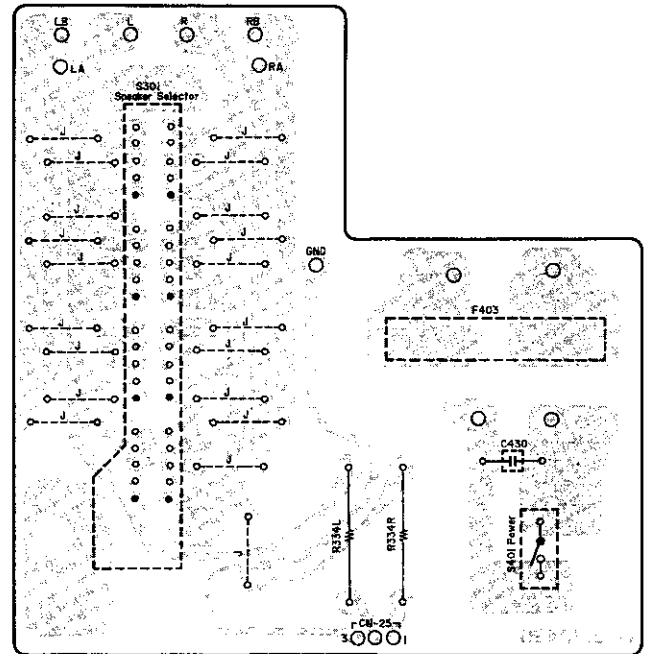

Fig. 6.2

6.3. Speaker Terminal P.C.B. Ass'y

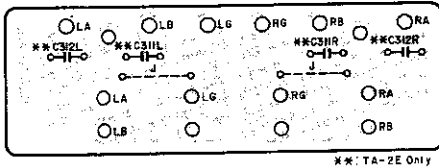

Fig. 6.3

Schematic Ref. No.	Part No.	Description	Schematic Ref. No.	Part No.	Description	Schematic Ref. No.	Part No.	Description
6.1. AC Outlet P.C.B. Ass'y			6.2. Power Switch P.C.B. Ass'y			6.3. Speaker Terminal P.C.B. Ass'y		
R418	BA07375A	AC Outlet P.C.B. Ass'y (TA-2A)	R334L,R C430 S301 S401 F403	BA07374A	Power Switch P.C.B. Ass'y (TA-2 (Australia)/2E)	C311L,R C312L,R	BA07614A	Speaker Terminal P.C.B. Ass'y (TA-2/20)
	BA07544A	AC Outlet P.C.B. Ass'y (TA-2 (Other)/20)		BA07612A	Power Switch P.C.B. Ass'y (TA-2 (Other))		BA07378A	Speaker Terminal P.C.B. Ass'y (TA-2A)
	OB60622A	AC Outlet P.C.B. RK 3.3M 1/2W J (TA-2A)		BA07372A	Power Switch P.C.B. Ass'y (TA-2A)		BA07392A	Speaker Terminal P.C.B. Ass'y (TA-2E)
	OB05919A	Insu-Lock 100 (3)		BA07373A	Power Switch P.C.B. Ass'y (TA-20)		OB60632A	Speaker Terminal P.C.B.
	OB08515A			OB60625A	Power Switch P.C.B. RF 330 2W		OB05582A	CML 0.022μ 50V J (TA-2E)
				OB24208A	CC 4700μ AC400V		OB05582A	CML 0.022μ 50V J (TA-2E)
				OB41829A	Rotary Switch 8P4C			
				OB70142A	Power Switch (TA-2/2A/2E)			
				OB71010A	Power Switch (TA-20)			
				OB71006A	Power Switch (TA-20)			
		OB90346A	Fuse T4A 250V (TA-2A)					
		OB81848A	Fuse Holder Z-N1152 (TA-2 (Australia)/2E) (2)					
		OB81930A	Fuse Holder SN-5051 (TA-2 (Other)/2A/20) (2)					

6.4. Headphone P.C.B. Ass'y

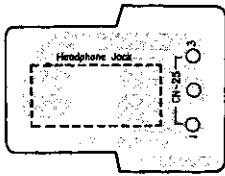

Fig. 6.4

6.5. Power LED P.C.B. Ass'y

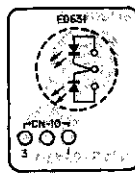

Fig. 6.5

6.6. Record Selector P.C.B. Ass'y

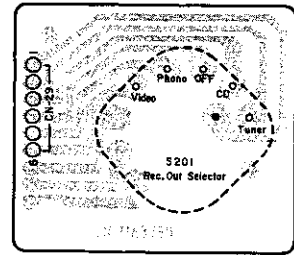

Fig. 6.6

6.7. Loudness P.C.B. Ass'y

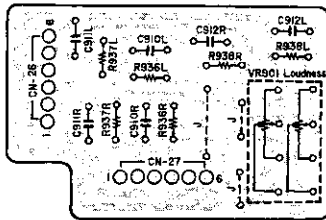

Fig. 6.7

6.8. Motor Volume P.C.B. Ass'y

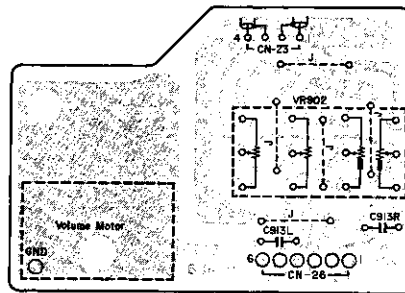

Fig. 6.8

6.9. IF Band Switch P.C.B. Ass'y

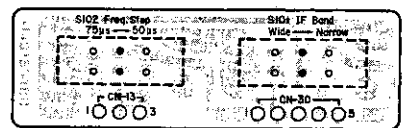

Fig. 6.9

Schematic Ref. No.	Part No.	Description	Schematic Ref. No.	Part No.	Description	Schematic Ref. No.	Part No.	Description
6.4. Headphone P.C.B. Ass'y			6.7. Loudness P.C.B. Ass'y			6.9. IF Band Switch P.C.B. Ass'y		
CN25	BA07381A	Headphone P.C.B. Ass'y	VR901 R936L,R R937L,R R938L,R C910L,R C911L,R C912L,R CN26 CN27	BA07380A	Loudness P.C.B. Ass'y	S101,102 CN13 CN30	BA07383A	IF Band Switch P.C.B. Ass'y (TA-2 (Other))
	OB60628A	Headphone P.C.B.		OB60627A	Loudness P.C.B.		OB60630A	IF Band Switch P.C.B.
	OB83511A OB81757A	Ribbon Wire 3P 140 Headphone Jack (1)		OB30097A OB09709A OB09699A OB09707A OB05550A OB05582A OB01780A OB83515A OB83502A	VR 300Kx2 RK 22K 1/6W J RK 8.2K 1/6W J RK 18K 1/6W J CML 1000P 50V J CML 0.022μ 50V J CML 0.1μ 50V J Ribbon Wire 6P 140 6P Connector Ass'y 300		OB70137A OB83492A	Slide Switch 3P Connector Ass'y 200
6.5. Power LED P.C.B. Ass'y			6.8. Motor Volume P.C.B. Ass'y				OB83500A	5P Connector Ass'y 300
ED631	BA07382A	Power LED P.C.B. Ass'y		BA07379A	Motor Volume P.C.B. Ass'y			
OB60629A OB12421A	Power LED P.C.B.			OB60626A	Motor Volume P.C.B.			
CN10	OB83512A	LED SPR-56PDWF Green/Red Ribbon Wire 3P 360		OB30096A OB41739A OB09292A OB83490A OB08515A OJ05703A	VR 50KBx2 CC 22P 50V J CC 0.1μ 50V Z 2P Connector Ass'y 200 Insu-Lock 100 (1) Lug Terminal 7 (1)			
6.6. Record Selector P.C.B. Ass'y								
S201 CN29	BA07385A	Record Selector P.C.B. Ass'y	VR902 C913L,913R C914 CN7					
	OB60621A	Record Selector P.C.B.						
	OB70141A OB83503A OB08515A	Rotary SW MSB15BP 6P Connector Ass'y 500 Insu-Lock 100 (1)						

6.10. Remote P.C.B. Ass'y

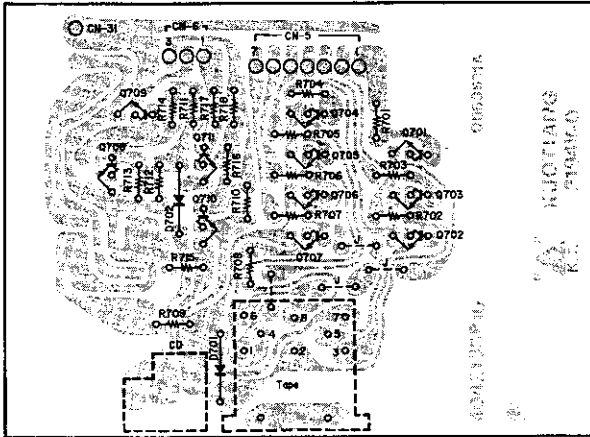

Fig. 6.10

6.11. Tone Control P.C.B. Ass'y

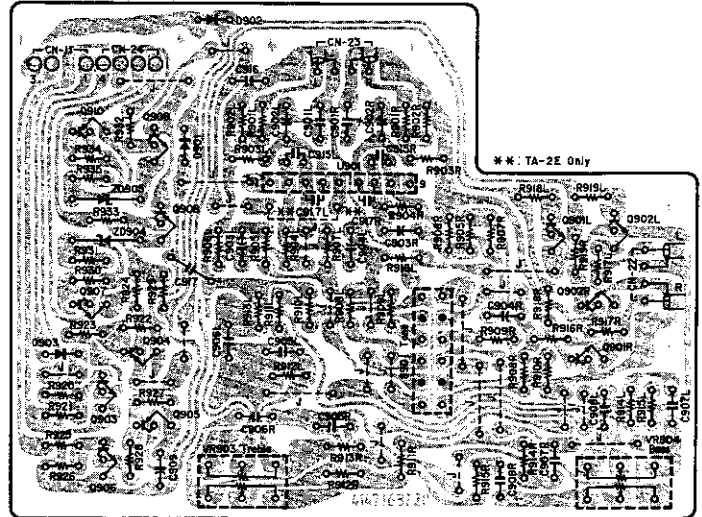

Fig. 6.11

Schematic Ref. No.	Part No.	Description	Schematic Ref. No.	Part No.	Description	Schematic Ref. No.	Part No.	Description
6.10. Remote P.C.B. Ass'y			6.11. Tone Control P.C.B. Ass'y			R935	OB09673A	RK 680 1/6W J
	BA07377A	Remote P.C.B. Ass'y		BA07384A	Tone Control P.C.B. Ass'y (TA-2/2A/20)	C901L,R	OB41394A	CPP 220P 50V J
		Remote P.C.B.		BA07591A	Tone Control P.C.B. Ass'y (TA-2E)	C902L,R	OB09222A	CE 0.47μ 50V (LN)
Q701,702	OB60631A	TR 2SC945 (P,Q)	U901	OB60620A	Tone Control P.C.B. IC μPC4570HA	C903L,R	OB09333A	CE 4.7μ 50V (LN)
Q703,704	OB06100A	TR 2SC945 (P,Q)	Q901L,R	OB11529A	TR 2SC2878	C904L,R	OB09148A	CE 10μ 25V (LN)
Q705,706	OB06100A	TR 2SC945 (P,Q)	Q902L,R	OB06299A	TR 2SC2878	C905L,R	OB01780A	CML 0.1μ 50V J
Q707,708	OB06100A	TR 2SC945 (P,Q)	Q903	OB06100A	TR 2SC945 (P,Q)	C906L,R	OB41304A	CML 0.33μ 50V J
Q709,710	OB06100A	TR 2SC945 (P,Q)	Q904,905	OB06013A	TR 2SA733 (P,Q)	C907L,R	OB05530A	CML 6800P 50V J
Q711	OB06100A	TR 2SC945 (P,Q)	Q906,907	OB06100A	TR 2SC945 (P,Q)	C908L,R	OB05583A	CML 0.033μ 50V J
D701,702	OB12584A	SID 1N4148	Q908	OB06013A	TR 2SA733 (P,Q)	C909	OB01502A	CE 330μ 16V
R701,702	OB09701A	RK 10K 1/6W J	Q909	OB06100A	TR 2SC945 (P,Q)	C915L,R	OB09279A	CC 22P 50V K
R703,704	OB09701A	RK 10K 1/6W J	Q910	OB06013A	TR 2SA733 (P,Q)	C917L,R	OB41735A	CC 100P 50V J (TA-2E)
R705,706	OB09701A	RK 10K 1/6W J	ZD904,905	OB12614A	ZD 12V B2	S901	OB70140A	Push Switch
R707	OB09701A	RK 10K 1/6W J	D901	OB06398A	SID 1SS176	CN11	OB83494A	3P Connector Ass'y 350
R708	OB09677A	RK 1K 1/6W J	D902	OB12584A	SID 1N4148	CN22	OB83498A	4P Connector Ass'y 500
R709	OB09637A	RK 22 1/6W J	D903	OB06398A	SID 1SS176	CN23A	OB83548A	Lead Wire 400
R710	OB09709A	RK 22K 1/6W J	VR903	OB30090A	VR 100KCx2	CN23B	OB83549A	Lead Wire 400
R711,712	OB09701A	RK 10K 1/6W J	VR904	OB30095A	VR 50KCx2	CN24	OB83496A	4P Connector Ass'y 400
R713,714	OB09701A	RK 10K 1/6W J	R901L,R	OB09669A	RK 470 1/6W J		OB08515A	Insu-Lock 100 (3)
R715	OB09637A	RK 22 1/6W J	R902L,R	OB09733A	RK 220K 1/6W J			
R716,717	OB09701A	RK 10K 1/6W J	R903L,R	OB09743A	RK 560K 1/6W J			
R718	OB09701A	RK 10K 1/6W J	R904L,R	OB09743A	RK 560K 1/6W J			
CN5	OB83504A	7P Connector Ass'y 250	R905L,R	OB22314A	RM 5.60K 1/6W F			
CN6	OB83493A	3P Connector Ass'y 250	R906L,R	OB22355A	RM 13.0K 1/6W F			
CN31	OB81985A	Pin 1.3	R907L,R	OB22457A	RM 100K 1/6W F			
	OB81754A	DIN Socket 8P (1)	R908L,R	OB22419A	RM 47.0K 1/6W F			
	OB81952A	Mini St Jack (1)	R909L,R	OB22361A	RM 15.0K 1/6W F			
			R910L,R	OB22276A	RM 2.70K 1/6W F			
			R911L,R	OB09697A	RK 6.8K 1/6W J			
			R912L,R	OB09723A	RK 82K 1/6W J			
			R913L,R	OB09683A	RK 1.8K 1/6W J			
			R914L,R	OB09673A	RK 680 1/6W J			
			R915L,R	OB09665A	RK 330 1/6W J			
			R916L,R	OB09677A	RK 1K 1/6W J			
			R917L,R	OB09653A	RK 100 1/6W J			
			R918L,R	OB09701A	RK 10K 1/6W J			
			R919L,R	OB09701A	RK 10K 1/6W J			
			R920	OB09701A	RK 10K 1/6W J			
			R921	OB09725A	RK 100K 1/6W J			
			R922,923	OB09717A	RK 47K 1/6W J			
			R924	OB09725A	RK 100K 1/6W J			
			R925,926	OB09701A	RK 10K 1/6W J			
			R927,928	OB09701A	RK 10K 1/6W J			
			R929	OB09725A	RK 100K 1/6W J			
			R930	OB09677A	RK 1K 1/6W J			
			R931	OB09673A	RK 680 1/6W J			
			R932,933	OB09677A	RK 1K 1/6W J			
			R934	OB09677A	RK 1K 1/6W J			

6.12. Power Supply P.C.B. Ass'y

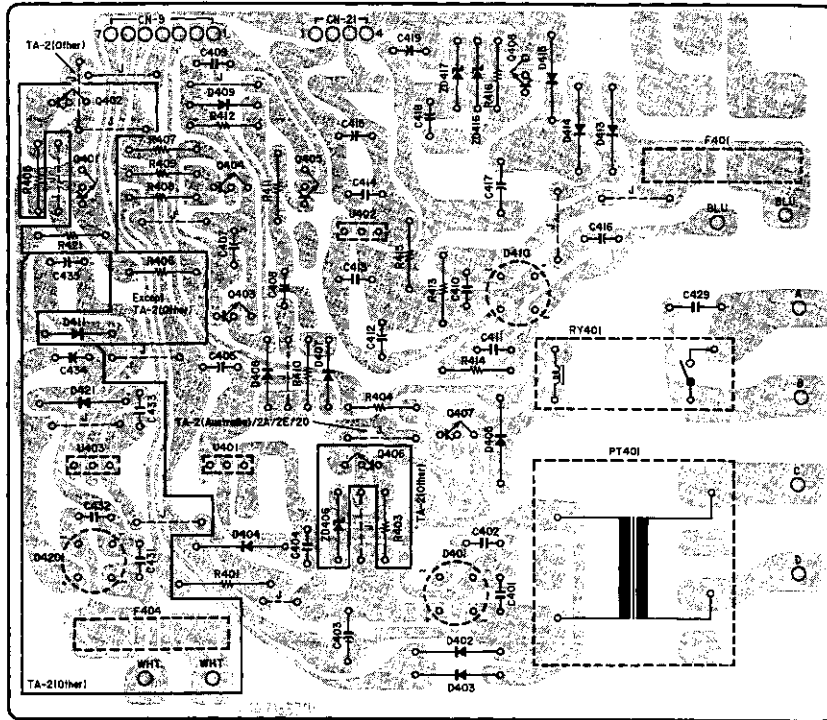

Fig. 6.12

Schematic Ref. No.	Part No.	Description	Schematic Ref. No.	Part No.	Description	Schematic Ref. No.	Part No.	Description
6.12. Power Supply P.C.B. Ass'y								
	BA07391A	Power Supply P.C.B. Ass'y (TA-2 (Other))	R401	OB24210A	RF 56 1W J	C433	OB09292A	CC 0.1μ 50V Z (TA-2 (Other))
	BA07393A	Power Supply P.C.B. Ass'y (TA-2 (Australia)/2E)	R402	OB20519A	RK 820 1/2W J (TA-2 (Other))	C434	OB40082A	CE 1000μ 16V (TA-2 (Other))
	BA07389A	Power Supply P.C.B. Ass'y (TA-2A)	R403	OB05622A	RK 2.2K 1/4W J	C435	OB05899A	CE 220μ 10V (TA-2 (Other))
	BA07390A	Power Supply P.C.B. Ass'y (TA-20)	R404	OB05576A	RK 470 1/4W J (Except TA-2 (Other))	RY401	OB90334A	Relay VS 12MB-VD3, TV-5
	OB60619A	Power Supply P.C.B. IC μPC7805H	R405	OB05615A	RK 22K 1/4W J (Except TA-2 (Other))	CN9	OB83505A	7P Connector Ass'y 400
U401	OB11010A	IC μPC7805H	R406	OB09263A	RK 12K 1/4W J	CN21	OB83497A	4P Connector Ass'y 450
U402	OB11011A	IC μPC7812H	R407	OB01889A	RK 100K 1/4W J	F401	OB90345A	Fuse T0.5A 250V (TA-2A)
U403	OB11010A	IC μPC7805H (TA-2 (Other))	R408	OB05615A	RK 22K 1/4W J	PT401	OB50141A	Sub Transformer (TA-2 (Australia)/2E)
Q401	OB06100A	TR 2SC945 (P,Q) (Except TA-2 (Other))	R409	OB01889A	RK 100K 1/4W J		OB50139A	Sub Transformer (TA-2 (Other))
Q402	OB10097A	TR 2SA952 (K,L) (Except TA-2 (Other))	R410	OB01682A	RK 6.8K 1/4W J		OB50137A	Sub Transformer (TA-2A)
Q403,404	OB06100A	TR 2SC945 (P,Q)	R411,412	OB01889A	RK 100K 1/4W J		OB50138A	Sub Transformer (TA-20)
Q405	OB06100A	TR 2SC945 (P,Q)	R413,414	OB01681A	RK 3.3K 1/4W J		OB08515A	Insu-Lock 100 (1)
Q406	OB10248A	TR 2SD313 (TA-2 (Other))	R415	OB05622A	RK 2.2K 1/4W J		OB81848A	Fuse Holder
Q407,408	OB06100A	TR 2SC945 (P,Q)	R416	OB05575A	RK 560 1/4W J		OE00766A	Z-N1152 (1)
ZD406	OB12390A	ZD 13V (TA-2 (Other))	R421	OB01888A	RK 10K 1/4W J (Except TA-2 (Other))		0J05720A	M3x8 ⊕ Binding (1)
ZD416,417	OB12615A	ZD 15V B2	C401,402	OB09292A	CC 0.1μ 50V Z			Heat Sink (1)
D401	OB12604A	SID W02M	C403	OB40082A	CE 1000μ 16V (Except TA-2 (Other))			
D402,403	OB12586A	SID 1N4002	C404	OB09292A	CC 0.1μ 50V Z			
D404,405	OB12586A	SID 1N4002	C405	OB05852A	CE 1000μ 10V			
D407,408	OB12584A	SID 1N4148	C407	OB09372A	CE 2.2μ 50V			
D409	OB12584A	SID 1N4148	C408	OB09372A	CE 2.2μ 50V			
D410	OB12604A	SID W02M	C409,410	OB09292A	CC 0.1μ 50V Z			
D411	OB12584A	SID 1N4148 (Except TA-2 (Other))	C411	OB09292A	CC 0.1μ 50V Z			
D413,414	OB12586A	SID 1N4002	C412	OB40095A	CE 1000μ 25V			
D415	OB12586A	SID 1N4002	C413,414	OB09292A	CC 0.1μ 50V Z			
D420	OB12604A	SID W02M (TA-2 (Other))	C415	OB40079A	CE 220μ 16V			
D421	OB12586A	SID 1N4002 (TA-2 (Other))	C416	OB40094A	CE 470μ 25V			
			C417	OB40123A	CE 470μ 50V			
			C418	OB40100A	CE 10μ 35V			
			C419	OB09126A	CE 100μ 35V			
			C429	OB41829A	CC 4700P AC400V			
			C431,432	OB09292A	CC 0.1μ 50V Z (TA-2 (Other))			

6.13. Control Switch & Display P.C.B. Ass'y

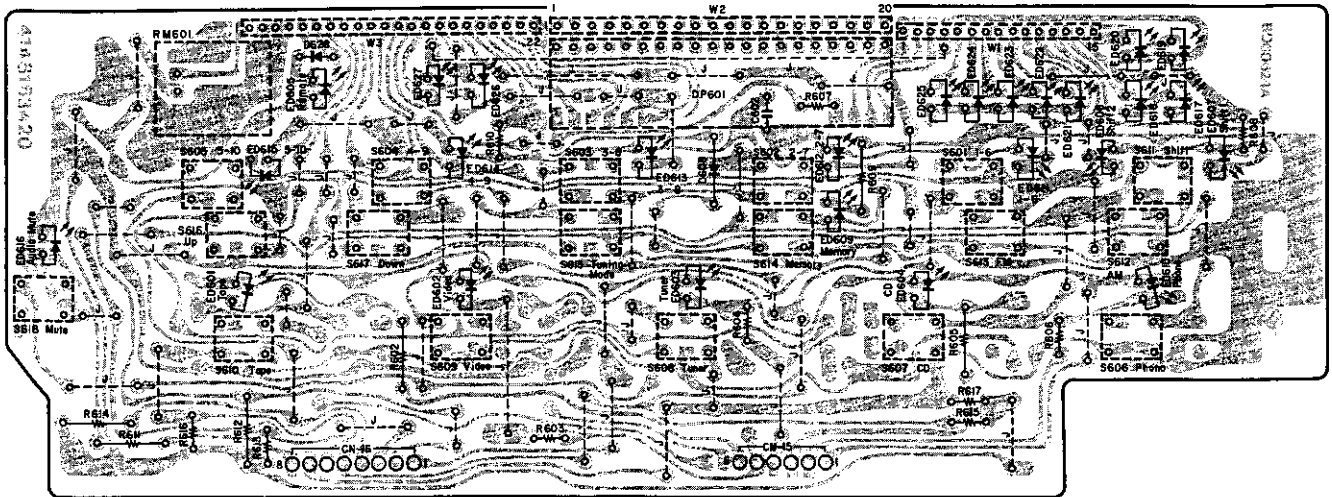

Fig. 6.13

Schematic Ref. No.	Part No.	Description	Schematic Ref. No.	Part No.	Description
6.13. Control Switch & Display P.C.B. Ass'y					
	BA07387A	Control Switch & Display P.C.B. Ass'y (TA-2/2A)	R608	OB09661A	RK 220 1/6W J
	BA07388A	Control Switch & Display P.C.B. Ass'y (TA-2E)	R609	OB01933A	RK 220 1/4W J
	BA07546A	Control Switch & Display P.C.B. Ass'y (TA-20)	R610	OB09661A	RK 220 1/6W J
	OB60624A	Control Switch & Display P.C.B.	R611	OB01933A	RK 220 1/4W J
RM601	OB11511A	IC BX1407	R612	OB01889A	RK 100K 1/4W J
ED601,602	OB12395A	LED SLR-34PC3F P-Green	R613	OB09725A	RK 100K 1/6W J
ED603,604	OB12395A	LED SLR-34PC3F P-Green	R614	OB01889A	RK 100K 1/4W J
ED605,606	OB12395A	LED SLR-34PC3F P-Green	R615,616	OB09725A	RK 100K 1/6W J
ED607	OB12395A	LED SLR-34PC3F P-Green	R617	OB09725A	RK 100K 1/6W J
ED609,610	OB12395A	LED SLR-34PC3F P-Green	C602	OB09290A	CC 0.01μ 50V Z
ED611,612	OB12395A	LED SLR-34PC3F P-Green	S601,602	OB70130A	TACT SW R66-3818
ED613,614	OB12395A	LED SLR-34PC3F P-Green	S603,604	OB70130A	TACT SW R66-3818
ED615,616	OB12395A	LED SLR-34PC3F P-Green	S605,606	OB70130A	TACT SW R66-3818
ED617,618	OB12625A	LED SLR-34PG3F P-Green	S607,608	OB70130A	TACT SW R66-3818
ED619,620	OB12625A	LED SLR-34PG3F P-Green	S609,610	OB70130A	TACT SW R66-3818
ED621,622	OB12395A	LED SLR-34PC3F P-Green	S611,612	OB70130A	TACT SW R66-3818
ED623,624	OB12395A	LED SLR-34PC3F P-Green	S613,614	OB70130A	TACT SW R66-3818
ED625	OB12395A	LED SLR-34PC3F P-Green	S615,616	OB70130A	TACT SW R66-3818
ED626,627	OB12625A	LED SLR-34PG3F P-Green	S617	OB70130A	TACT SW R66-3818
D608	OB12584A	SID 1N4148	S618	OB70130A	TACT SW R66-3818
D628	OB06398A	SID 1SS176	CN15	OB83516A	Ribbon Wire 6P 260
DP601	OB12608A	LED Display LTF-2401 (TA-2/2A)	CN16	OB83513A	Ribbon Wire 4P 260
	OB12616A	LED Display LTF-2501 (TA-2E/20)	A-A	OB83528A	Lead Wire 100
R602	OB01857A	RK 1K 1/4W J	W1	OB83519A	Flat Wire 15P 70
R603,604	OB09677A	RK 1K 1/6W J	W2	OB83521A	Flat Wire 20P 70
R605	OB01857A	RK 1K 1/4W J	W3	OB83520A	Flat Wire 18P 70 (TA-2/2A/20)
R606	OB09677A	RK 1K 1/6W J	W3	OB83670A	Flat Wire 22P 70 (TA-2E)
R607	OB09669A	RK 470 1/6W J		OE00868A	BT3x8 @ Binding (2)
				OH05428A	Display Reflector (1)
				OJ05416A	LED Reflector (5)

Schematic Ref. No.	Part No.	Description	Schematic Ref. No.	Part No.	Description	Schematic Ref. No.	Part No.	Description
6.14. Logic P.C.B. Ass'y			R542	OB09693A	RK 4.7K 1/6W J (TA-2 (Other)/2E)	C537	OB09291A	CC 0.022μ 50V Z
	BA07562A	Logic P.C.B. Ass'y (TA-2 (Other))	R543,544	OB09701A	RK 10K 1/6W J (TA-2 (Other)/2E)	CN1	OB83491A	2P Connector Ass'y 300
	BA07376A	Logic P.C.B. Ass'y (TA-2 (Australia)/ 2E)	R545,546	OB09701A	RK 10K 1/6W J (TA-2 (Other)/2E)	CN2	OB81762A	5P-T Post
	BA07386A	Logic P.C.B. Ass'y (TA-2A)	R547	OB09709A	RK 22K 1/6W J (TA-2 (Other)/2E)	CN3	OB83501A	5P Connector Ass'y 200
	BA07545A	Logic P.C.B. Ass'y (TA-20)	R548,549	OB09717A	RK 47K 1/6W J	CN4	OB83495A	4P Connector Ass'y 150
	OB60623A	Logic P.C.B.	R550	OB09717A	RK 47K 1/6W J	CN5	OB81764A	7P-T Post
U501	OB11159A	IC TD6104P	R551,552	OB09661A	RK 220 1/6W J	CN6	OB81760A	5P Connector Ass'y
U502	OB01161A	IC TC9147BP	R553,554	OB09661A	RK 220 1/6W J	CN7	OB81759A	2P-T Post
U503	OB11502A	IC μPD75104CW	R555,556	OB09661A	RK 220 1/6W J	CN8	OB83504A	7P Connector Ass'y 250
U504	OB11160A	IC TD6301AP	R557,558	OB09661A	RK 220 1/6W J	CN9	OB81764A	7P-T Post
U505	OB11244A	IC LB1413N	R559,560	OB09661A	RK 220 1/6W J	CN11	OB81760A	3P-T Post
U506	OB11530A	IC BA6208	R561,562	OB09661A	RK 220 1/6W J	CN13	OB81760A	3P-T Post
Q501,502	OB10265A	TR 2SC1842 (E)	R563,564	OB09661A	RK 220 1/6W J			(TA-2 (Other))
Q503	OB06013A	TR 2SA733 (P,Q)	R565,566	OB09661A	RK 220 1/6W J	CN14	OB81762A	5P-T Post
Q504,505	OB06100A	TR 2SC945 (P,Q)	R567,568	OB09661A	RK 220 1/6W J	E-E	OB83530A	Lead Wire 160
Q506,507	OB06100A	TR 2SC945 (P,Q)	R569	OB09661A	RK 220 1/6W J	F-F	OB83531A	Lead Wire 140
Q508	OB06013A	TR 2SA733 (P,Q)	R570,571	OB09661A	RK 220 1/6W J	G-G	OB83532A	Lead Wire 80
Q509,510	OB06100A	TR 2SC945 (P,Q)	R572	OB09653A	RK 100 1/6W J	H-H	OB83508A	Ribbon Wire 2P 120
		(TA-2 (Other)/2E)	R573	OB09307A	RK 4.3K 1/4W J	L-L	OB83688A	Ribbon Wire 4P
		(TA-2 (Other)/2E)	R574	OB09661A	RK 220 1/6W J (TA-2 (Other)/2E)	M-M	OB83534A	Lead Wire 80
Q511,512	OB06100A	TR 2SC945 (P,Q)	R575	OB09654A	RK 110 1/6W J (TA-2 (Other)/2E)		OJ05751A	Shield Plate A (1)
		(TA-2 (Other)/2E)	R576	OB09654A	RK 110 1/6W J (TA-2 (Other)/2E)		OJ05752A	Shield Plate B (1)
Q513,514	OB06100A	TR 2SC945 (P,Q)	R577	OB09654A	RK 110 1/6W J (TA-2 (Other)/2E)			
Q515,516	OB06100A	TR 2SC945 (P,Q)	R578	OB09665A	RK 330 1/6W J			
Q517,518	OB06100A	TR 2SC945 (P,Q)	R579	OB05576A	RK 470 1/4W J			
Q519,520	OB06100A	TR 2SC945 (P,Q)	R580	OB09657A	RK 150 1/6W J			
Q521,522	OB06100A	TR 2SC945 (P,Q)	R581	OB09669A	RK 470 1/6W J			
Q523,524	OB06100A	TR 2SC945 (P,Q)	R582	OB09677A	RK 1K 1/6W J			
Q525	OB06013A	TR 2SA733 (P,Q)	R583	OB09701A	RK 10K 1/6W J			
Q526	OB10263A	TR 2SC2060	R584	OB09717A	RK 47K 1/6W J			
Q527	OB06100A	TR 2SC945 (P,Q)	R586,587	OB01888A	RK 10K 1/4W J			
ZD520	OB12156A	ZD 6.8V B2	R588,589	OB01888A	RK 10K 1/4W J			
D501	OB12584A	SID 1N4148	R590,591	OB01888A	RK 10K 1/4W J			
D502	OB06398A	SID 1SS176	R592	OB01888A	RK 10K 1/4W J			
D503,504	OB12584A	SID 1N4148	R593,594	OB09701A	RK 10K 1/6W J			
D505,506	OB06398A	SID 1SS176	R595	OB09701A	RK 10K 1/6W J			
D507	OB12584A	SID 1N4148	R596,597	OB01888A	RK 10K 1/4W J			
D508	OB06398A	SID 1SS176	R598	OB09701A	RK 10K 1/6W J			
D511,512	OB06398A	SID 1SS176	R599	OB09677A	RK 1K 1/6W J			
D513	OB06398A	SID 1SS176	R5100	OB09701A	RK 10K 1/6W J			
D514	OB12584A	SID 1N4148	R5101	OB01933A	RK 220 1/4W J			
L501	OB51274A	Coil 220 K-P	R5113	OB09707A	RK 18K 1/6W J			
L502	OB51291A	Coil 470μH K	R5114	OB01889A	RK 100K 1/4W J			
X501	OB92006A	X'tal 7.2MHz	R5115	OB09661A	RK 220 1/6W J			
X502	OB92014A	Ceramic Resonator 4MHz	R5116	OB09657A	RK 150 1/6W J			
R501	OB09677A	RK 1K 1/6W J	R5117	OB01889A	RK 100K 1/4W J			
R502	OB09661A	RK 220 1/6W J (TA-2/2A/20)	C501	OB09288A	CC 1000P 50V K			
	OB09665A	RK 330 1/6W J (TA-2E)	C502	OB05899A	CE 220μ 10V			
R503,504	OB09721A	RK 68K 1/6W J	C503	OB09291A	CC 0.022μ 50V Z			
R505	OB09725A	RK 100K 1/6W J	C504	OB41900A	CC 39P 50V J (TA-2/2A/2E)			
R506	OB01889A	RK 100K 1/4W J (TA-2/2A/2E)	C505	OB09586A	CC 2200P 50V K			
R507	OB09725A	RK 100K 1/6W J	C506	OB09290A	CC 0.01μ 50V Z			
R508	OB01888A	RK 10K 1/4W J	C507	OB01405A	CE 1μ 50V			
R509	OB09677A	RK 1K 1/6W J	C508	OB01400A	CE 100μ 16V			
R510	OB09699A	RK 8.2K 1/6W J	C509,510	OB09291A	CC 0.022μ 50V Z			
R511	OB01888A	RK 10K 1/4W J	C511	OB40067A	CE 470μ 10V			
R512	OB00346A	RK 1K 1/2W J	C512,513	OB41740A	CC 33P 50V J			
R513	OB01888A	RK 10K 1/4W J	C514	OB01405A	CE 1μ 50V			
R514	OB01889A	RK 100K 1/4W J	C515	OB40025A	CE 0.47μ 50V			
R515,516	OB09725A	RK 100K 1/6W J	C516	OB09327A	CE 0.33μ 50V (LN)			
R517	OB01889A	RK 100K 1/4W J	C517	OB01780A	CML 0.1μ 50V J			
R518,519	OB09697A	RK 6.8K 1/6W J	C518	OB40103A	CE 47μ 35V			
R520,521	OB01857A	RK 1K 1/4W J	C519,520	OB09793A	CC 30P 50V J			
R522,523	OB09677A	RK 1K 1/6W J	C521	OB09387A	CC 0.047μ 50V Z			
R524,525	OB09677A	RK 1K 1/6W J	C522	OB09291A	CC 0.022μ 50V Z			
R526,527	OB09677A	RK 1K 1/6W J	C523,524	OB01674A	CE 10μ 25V			
R528,529	OB09677A	RK 1K 1/6W J	C525	OB01409A	CE 47μ 25V			
R530,531	OB09677A	RK 1K 1/6W J	C526	OB40117A	CE 22μ 50V			
R532	OB09677A	RK 1K 1/6W J	C527	OB09291A	CC 0.022μ 50V Z			
R533	OB09689A	RK 3.3K 1/6W J	C530	OB41737A	CC 330P 50V J			
R534	OB09683A	RK 1.8K 1/6W J	C531	OB09291A	CC 0.022μ 50V Z			
R535	OB09689A	RK 3.3K 1/6W J	C532	OB40115A	CE 4.7μ 50V			
R536,537	OB09701A	RK 10K 1/6W J	C533,534	OB09286A	CC 470P 50V K			
R538,539	OB09701A	RK 10K 1/6W J	C535,536	OB09291A	CC 0.022μ 50V Z			
R540	OB01888A	RK 10K 1/4W J (TA-2 (Other)/2E)						
R541	OB09701A	RK 10K 1/6W J (TA-2 (Other)/2E)						

6.14. Logic P.C.B. Ass'y

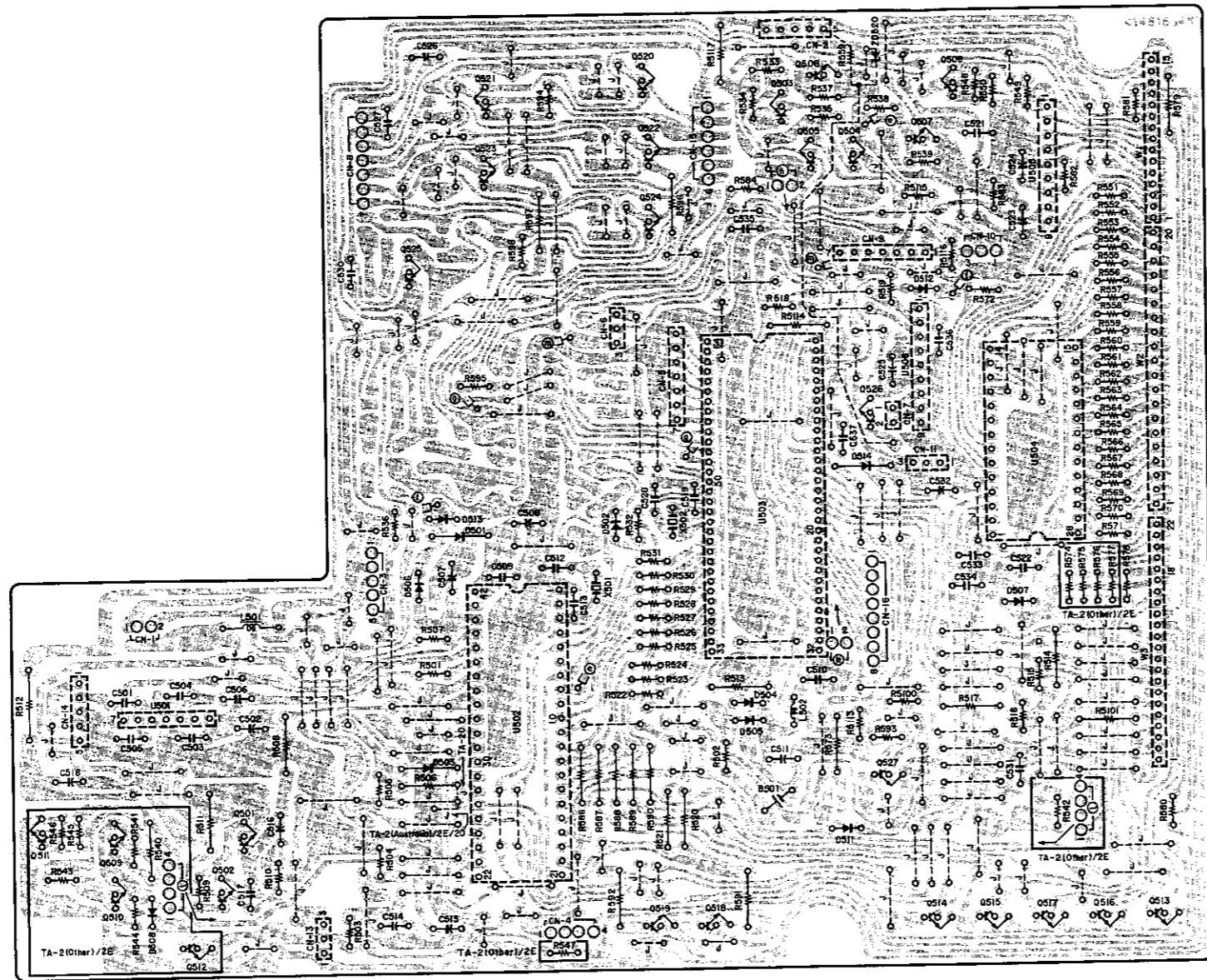

Fig. 6.14

6.15. Main P.C.B. Ass'y

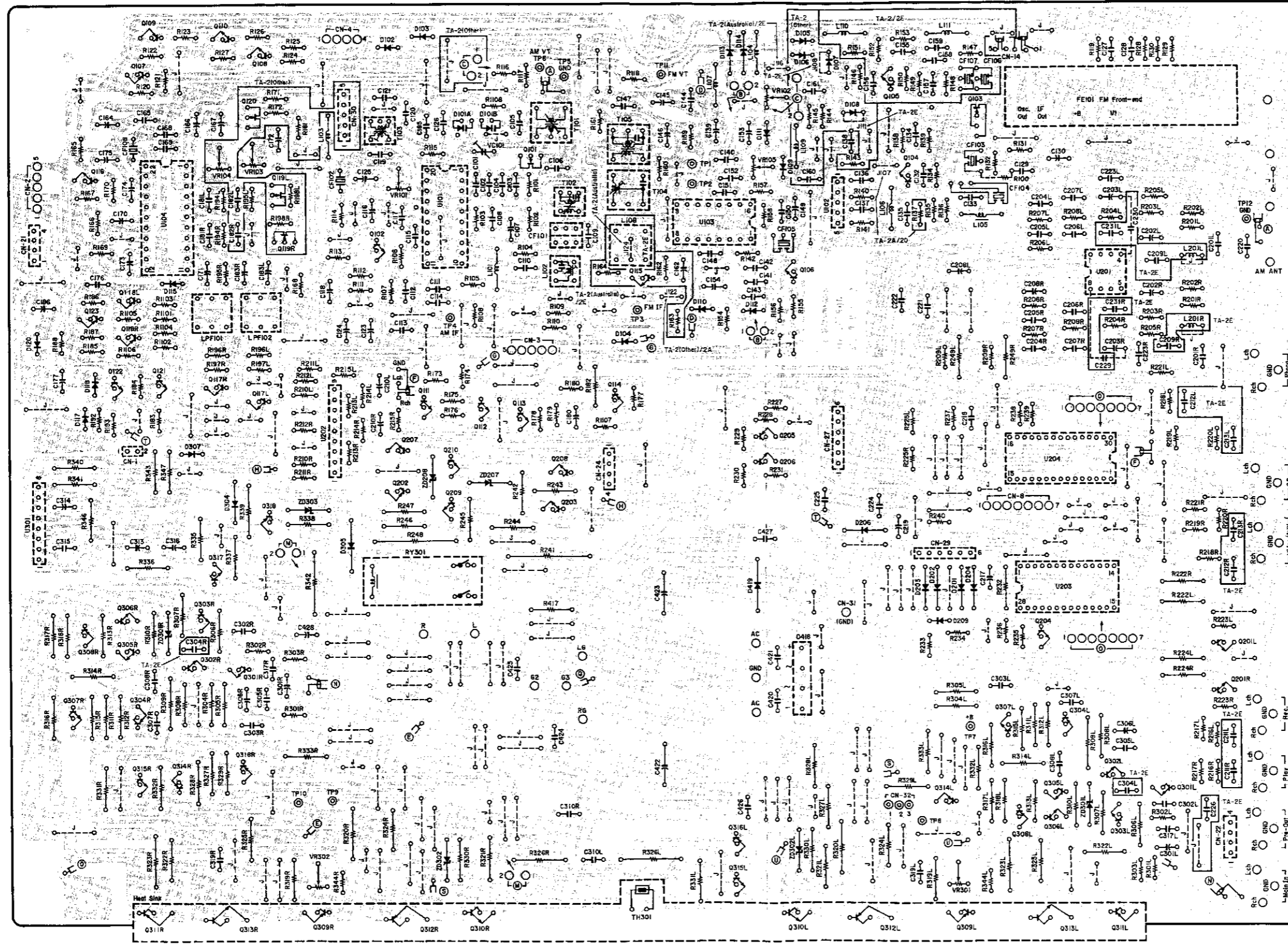

Fig. 6.15

Schematic Ref. No.	Part No.	Description
6.15. Main P.C.B. Ass'y		
	BA07369A	Main P.C.B. Ass'y (TA-2 (Other))
	BA07370A	Main P.C.B. Ass'y (TA-2 (Australia))
	BA07367A	Main P.C.B. Ass'y (TA-2A)
	BA07371A	Main P.C.B. Ass'y (TA-2E)
	BA07368A	Main P.C.B. Ass'y (TA-20)
	OB60618A	Main P.C.B.
U101	OB11243A	IC LA1247
U102	OB11156A	IC TA7060AP
U103	OB11157A	IC LA1235
U104	OB11245A	IC LA3400N
U201	OB06387A	IC NJM2043DD
U202	OB11050A	IC NJM4558S
U203	OB11514A	IC LC7816
U204	OB11531A	IC LC7818
U301	OB11246A	IC μ PC1237H
Q101	OB06129A	FET 2SK117 (Y)
Q102	OB06100A	TR 2SC945 (P,Q)
Q103	OB10127A	FET 2SK241 (GR)
Q104	OB06115A	TR 2SC1675 (K,L)
Q105	OB06115A	TR 2SC1675 (K,L) (TA-2/2E)
Q106	OB06100A	TR 2SC945 (P,Q)
Q107	OB10097A	TR 2SA952 (K,L)
Q108	OB06100A	TR 2SC945 (P,Q)
Q109	OB10097A	TR 2SA952 (K,L)
Q110,111	OB06100A	TR 2SC945 (P,Q)
Q112,113	OB06100A	TR 2SC945 (P,Q)
Q114	OB06013A	TR 2SA733 (P,Q)
Q115	OB06100A	TR 2SC945 (P,Q) (TA-2 (Australia)/2E)
Q116	OB06100A	TR 2SC945 (P,Q)
Q117L,R	OB06299A	TR 2SC2878
Q118L,R	OB06013A	TR 2SA733 (P,Q)
Q119L,R	OB10151A	FET 2SK364 (TA-2 (Other))
Q120	OB10151A	FET 2SK364 (TA-2 (Other))
Q121,122	OB06100A	TR 2SC945 (P,Q)
Q123	OB06013A	TR 2SA733 (P,Q)
Q201L,R	OB06299A	TR 2SC2878
Q202	OB06372A	TR 2SA953 (K,L)
Q203	OB06322A	TR 2SC2002 (K,L)
Q204	OB06100A	TR 2SC945 (P,Q)
Q205	OB06013A	TR 2SA733 (P,Q)
Q206	OB06100A	TR 2SC945 (P,Q)
Q207	OB10264A	TR 2SB507 (E)
Q208	OB10248A	TR 2SD313 (E)
Q209	OB06100A	TR 2SC945 (P,Q)
Q210	OB06013A	TR 2SA733 (P,Q)
Q301L,R	OB06142A	TR 2SC2240 (BL)
Q302L,R	OB06142A	TR 2SC2240 (BL)
Q303L,R	OB06142A	TR 2SC2240 (BL)
Q304L,R	OB10050A	TR 2SA970 (BL)
Q305L,R	OB06142A	TR 2SC2240 (BL)
Q306L,R	OB06142A	TR 2SC2240 (BL)
Q307L,R	OB06142A	TR 2SC2240 (BL)
Q308L,R	OB10050A	TR 2SA970 (BL)
Q314L,R	OB10050A	TR 2SA970 (BL)
Q315L,R	OB06142A	TR 2SC2240 (BL)
Q316L,R	OB10050A	TR 2SA970 (BL)
Q317	OB06322A	TR 2SC2002 (K,L)
Q318	OB06372A	TR 2SA953 (K,L)
ZD207,208	OB12627A	ZD 18V B2
ZD301L,R	OB06298A	ZD 8.2V B2
ZD302L,R	OB12614A	ZD 12V B2
ZD303	OB12614A	ZD 12V B2
D101	OB12606A	Varicap KVF1236Z1
D102,103	OB06398A	SID 1SS176
D104	OB06398A	SID 1SS176
D105,106	OB06398A	SID 1SS176 (TA-2 (Other))
D107,108	OB06398A	SID 1SS176 (TA-2 (Other))
D109,110	OB06398A	SID 1SS176
D111,112	OB06398A	SID 1SS176
D113,114	OB12584A	SID 1N4148
D115	OB06398A	SID 1SS176
D117	OB06398A	SID 1SS176
D118	OB06398A	SID 1SS176

Schematic Ref. No.	Part No.	Description	Schematic Ref. No.	Part No.	Description	Schematic Ref. No.	Part No.	Description	Schematic Ref. No.	Part No.	Description	Schematic Ref. No.	Part No.	Description	Schematic Ref. No.	Part No.	Description
D120	OB06398A	SID 1SS176	R132	OB09661A	RK 220 1/6W J	OB09721A	RK 68K 1/6W J	VC101	OB42010A	C Trimmer 10P	C208L,R	OB09223A	CE 1μ 50V (LN)	OB81977A	Antenna Terminal F		
D201,202	OB12584A	SID 1N4148	R134	OB09667A	RK 390 1/6W J			C101	OB09288A	CC 1000P 50V K	C209L,R	OB41738A	CC 390P 50V J	OB81979A	Antenna Terminal		
D203,204	OB12584A	SID 1N4148	R135	OB09698A	RK 7.5K 1/6W F	R212L,R	OB09725A	RK 100K 1/6W J	OB09291A	CC 0.022μ 50V Z							
D206	OB12584A	SID 1N4148	R136	OB09686A	RK 2.4K 1/6W J	R213L,R	OB09725A	RK 100K 1/6W J	OB09288A	CC 1000P 50V K	C210L,R	OB09148A	CE 10μ 25V (LN)	OB81980A	Pin Jack 2P		
D209	OB06398A	SID 1SS176	R137	OB09665A	RK 330 1/6W J	R214L,R	OB09725A	RK 470 1/6W J	OB09291A	CC 0.022μ 50V Z	C211L,R	OB05550A	CML 1000P 50V J	OB81981A	Pin Jack 4P		
D304	OB12584A	SID 1N4148			(TA-2A/20)	R215L,R	OB09725A	RK 100K 1/6W J	OB01403A	CE 47μ 16V				OB05670A	Earth Plate		
D305	OB12586A	SID 1N4002	R138	OB09645A	RK 47 1/6W J	R216L,R	OB09719A	RK 56K 1/6W J	OB09291A	CC 0.022μ 50V Z	C212L,R	OB05550A	CML 1000P 50V J				
D307	OB06398A	SID 1SS176	R139,140	OB09667A	RK 390 1/6W J	R217L,R	OB09645A	RK 47 1/6W J	OB41908A	CC 82P 50V J							
D418	OB12626A	SID KBU6D	R141	OB09667A	RK 390 1/6W J	R218L,R	OB09719A	RK 56K 1/6W J	OB09291A	CC 0.022μ 50V Z	C213L,R	OB05550A	CML 1000P 50V J				
D419	OB12586A	SID 1N4002	R142	OB09665A	RK 330 1/6W J	R219L,R	OB09645A	RK 47 1/6W J	OB09288A	CC 1000P 50V K							
FE101	OB91027A	Front End	R143	OB09689A	RK 3.3K 1/6W J	R220L,R	OB09719A	RK 56K 1/6W J	OB05582A	CML 0.022μ 50V J	C217	OB01405A	CE 1μ 50V				
		FE415-A03			(TA-2 (Other))	R221L,R	OB09645A	RK 47 1/6W J	OB01802A	CML 2200P 50V J	C218	OB09887A	CC 0.047μ 50V Z				
		(TA-2/2A)	R144	OB09665A	RK 330 1/6W J	R222L,R	OB01857A	RK 1K 1/4W J	OB05685A	CML 0.082μ 50V J	C219	OB01405A	CE 1μ 50V				
	OB91032A	Front End			(TA-2 (Other))	R223L,R	OB09725A	RK 100K 1/6W J	OB09290A	CC 0.01μ 50V Z	C220	OB01780A	CML 0.1μ 50V J				
		FE415-J03 (TA-20)	R145,146	OB09693A	RK 4.7K 1/6W J	R224L,R	OB05615A	RK 22K 1/4W J	OB40025A	CE 0.47μ 50V							
		Front End			(TA-2 (Other))	R225L,R	OB09733A	RK 220K 1/6W J	OB09291A	CC 0.022μ 50V Z							
		FE415-G07 (TA-2E)	R147,148	OB09665A	RK 330 1/6W J	R227	OB09717A	RK 47K 1/6W J	OB01403A	CE 47μ 16V	C221,222	OB09292A	CC 0.1μ 50V Z				
CF101	OB41897A	Ceramic Filter	R149	OB09698A	RK 7.5K 1/6W J	R228	OB09719A	RK 10K 1/6W J	OB09291A	CC 0.022μ 50V Z	C223L,R	OB05681A	CML 0.01μ 50V J				
		SFZ450G3L			(TA-2/2E)	R229	OB09717A	RK 47K 1/6W J	OB41896A	CSP 390P 50V J	C224,225	OB09292A	CC 0.1μ 50V Z				
CF102	OB41898A	Ceramic Filter	R150	OB09689A	RK 3.3K 1/6W J	R230	OB09701A	RK 10K 1/6W J	OB41905A	CC 5P 50V J	C226	OB09292A	CC 0.1μ 50V Z				
		BFU450C4N			(TA-2/2E)	R231	OB09713A	RK 33K 1/6W J	OB40029A	CE 4.7μ 50V							
CF103,104	OB41918A	Ceramic Filter	R151	OB09671A	RK 560 1/6W J	R232	OB05625A	RK 220K 1/4W J	OB09372A	CE 2.2μ 50V	C229,230	OB09291A	CC 0.022μ 50V Z				
		SFE10.7MLNA			(TA-2/2E)	R233	OB09725A	RK 100K 1/6W J	OB09291A	CC 0.022μ 50V Z	C231L,R	OB41735A	CC 100P 50V J				
CF105	OB41918A	Ceramic Filter	R152	OB09646A	RK 51 1/6W J	R234	OB09713A	RK 33K 1/6W J	OB09387A	CC 0.047μ 50V Z							
		SFE10.7MLNA			(TA-2/2E)	R235	OB09701A	RK 10K 1/6W J	OB09291A	CC 0.022μ 50V Z							
CF106	OB41928A	Ceramic Filter	R153	OB09677A	RK 1K 1/6W J	R236	OB09709A	RK 22K 1/6W J	OB40079A	CE 220μ 16V	C301L,R	OB09148A	CE 10μ 25V (LN)				
		SFZ10.7MS3			(TA-2/2E)	R237	OB09733A	RK 220K 1/6W J	OB09291A	CC 0.022μ 50V Z	C302L,R	OB41213A	CPP 330P 100V J				
		(TA-2/2E)			(TA-2/2E)	R238	OB09725A	RK 100K 1/6W J	OB09291A	CC 0.022μ 50V Z	C303L,R	OB05652A	CML 4700P 50V J				
CF107	OB41928A	Ceramic Filter	R154,155	OB09717A	RK 47K 1/6W J	R239	OB09725A	RK 100K 1/6W J	OB09291A	CC 0.022μ 50V Z	C304L,R	OB09286A	CC 470P 50V K				
		SFZ10.7MS3			(TA-2/2E)	R240	OB09725A	RK 100K 1/6W J	OB09291A	CC 0.022μ 50V Z							
		(TA-2/2E)			(TA-2/2E)	R241	OB24207A	RF 220 2W J	OB40079A	CE 220μ 16V							
CF108	OB41927A	Ceramic Resonator	R158	OB09719A	RK 56K 1/6W J	R242	OB05622A	RK 2.2K 1/4W J	OB09291A	CC 0.022μ 50V Z	C305L,R	OB05681A	CML 0.01μ 50V J				
		CSB456F11			(TA-2 (Australia))	R243	OB05794A	RK 680 1/4W J	OB09291A	CC 0.022μ 50V Z	C306L,R	OB40434A	CE 220μ 25V (LN)				
T101	OB51269A	Coil AM ANT	R159	OB09705A	RK 15K 1/6W J	R244,245	OB05622A	RK 2.2K 1/4W J	OB09291A	CC 0.022μ 50V Z	C307L,R	OB09279A	CC 22P 50V K				
T102	OB51271A	Coil AM IFT	R160	OB09700A	RK 9.1K 1/6W J	R246	OB05794A	RK 680 1/4W J	OB09291A	CC 0.022μ 50V Z	C308L,R	OB09279A	CC 22P 50V K				
T103	OB51270A	Coil AM OSC	R161	OB09683A	RK 1.8K 1/6W J	R247	OB05622A	RK 2.2K 1/4W J	OB09291A	CC 0.022μ 50V Z	C309L,R	OB09279A	CC 22P 50V K				
T104	OB51293A	Coil FM DET A	R162	OB09745A	RK 680K 1/6W J	R248	OB24207A	RF 220 2W J	OB01405A	CE 1μ 50V	C310L,R	OB01780A	CML 0.1μ 50V J				
T105	OB51294A	Coil FM DET B			(TA-2 (Australia))	R249L,R	OB05576A	RK 470 1/4W J	OB09291A	CC 0.022μ 50V Z	C313	OB01400A	CE 100μ 16V				
L101	OB51274A	Coil 22μH	R163	OB09693A	RK 4.7K 1/6W J	R301L,R	OB09717A	RK 47K 1/6W J	OB09291A	CC 0.022μ 50V Z	C314	OB40250A	CE 100μ 16V (BP)				
L102	OB51292A	Coil AM IFT (A)			(TA-2 (Australia))	R302L,R	OB09669A	RK 470 1/6W J	OB09291A	CC 0.022μ 50V Z	C316	OB01674A	CE 10μ 25V				
L103,104	OB51274A	Coil 22μH			(TA-2 (Australia))	R303L,R	OB22409A	RM 39.0K 1/6W F	OB09291A	CC 0.022μ 50V Z	C317L,R	OB05796A	CML 0.047μ 50V J				
L105,106	OB51274A	Coil 22μH	R164	OB09687A	RK 2.7K 1/6W J	R304L,R	OB22635A	RM 1.21K 1/4W F	OB40029A	CE 4.7μ 50V	C319L,R	OB41176A	CML 0.22μ 63V J				
L107	OB51274A	Coil 22μH			(TA-2 (Australia))	R305L,R	OB01679A	RK 100 1/4W J	OB09372A	CE 2.2μ 50V	C420,421	OB41901A	CC 0.022μ 500V Z				
L108	OB51289A	Low Pass Filter			(TA-2 (Australia))	R306L,R	OB01683A	RK 15K 1/4W J	OB09291A	CC 0.022μ 50V Z	C422,423	OB40516A	CE 6800μ 63V				
		(TA-2E)	R165	OB09717A	RK 47K 1/6W J	R307L,R	OB05691A	RK 390 1/4W J	OB09291A	CC 0.022μ 50V Z	C424,425	OB41476A	CML 0.1μ 63V J				
L109	OB51274A	Coil 22μH	R166	OB09701A	RK 10K 1/6W J	R308L,R	OB09419A	RM 2K 1/4W F	OB09291A	CC 0.022μ 50V Z	C426,427	OB41476A	CML 0.1μ 63V J				
		(TA-2 (Other))	R167	OB09717A	RK 47K 1/6W J	R309L,R	OB20518A	RK 22K 1/2W J	OB09291A	CC 0.022μ 50V Z	C428	OB40029A	CE 4.7μ 50V				
L110	OB51274A	Coil 22μH	R168	OB09721A	RK 68K 1/6W J	R310L,R	OB01846A	RK 4.7K 1/4W J	OB09291A	CC 0.022μ 50V Z	RY301	OB90331A	Relay VB 24MBU				
		(TA-2/2E)	R169	OB09669A	RK 470 1/6W J	R311L,R	OB05959A	RK 75 1/4W J	OB09291A	CC 0.022μ 50V Z	CN1	OB81759A	2P-T Post				
L111	OB51274A	Coil 22μH	R170	OB09689A	RK 3.3K 1/6W J	R312L,R	OB24218A	RF 1.2K 1/4W J	OB09291A	CC 0.022μ 50V Z	CN2	OB83500A	5P Connector Ass'y				
		(TA-2/2E)	R171	OB09749A	RK 1M 1/6W J	R313L,R	OB01933A	RK 220 1/4W J									
L201L,R	OB81304A	Coil 80μH (TA-2E)			(TA-2 (Other))	R314L,R	OB09560A	RM 39K 1/4W F	OB01674A	CE 10μ 25V	CN3	OB81762A	5P-T Post				
LFP101,102	OB51295A	Coil FM MPX Trap	R172	OB09725A	RK 100K 1/6W J	R315L,R	OB24214A	RF 75 1/4W J			CN4	OB81761A	4P-T Post				
VR101	OB32130A	Semi VR 100K			(TA-2 (Other))	R316L,R	OB05622A	RK 2.2K 1/4W J			CN8	OB81764A	7P-T Post				
VR102	OB32127A	Semi VR 100K	R173	OB09725A	RK 100K 1/6W J	R317L,R	OB05622A	RK 2.2K 1/4W J	C164	OB40080A	CE 330μ 16V	CN14	OB83499A	5P Connector Ass'y			
VR103	OB32130A	Semi VR 100K	R174,175	OB09701A	RK 10K 1/6W J	R318L,R	OB24214A	RF 75 1/4W J	C165	OB09291A	CC 0.022μ 50V Z						
VR104	OB32130A	Semi VR 100K	R176,177	OB09701A	RK 10K 1/6W J	R319L,R	OB01682A	RK 6.8K 1/4W J	C166,167	OB09148A	CE 10μ 25V (LN)	CN21	OB81761A	4P-T Post			
		(TA-2 (Other))	R178	OB09701A	RK 10K 1/6W J	R320L,R	OB24212A	RF 10 1/2W J	C168	OB09287A	CC 680P 50V K	CN22	OB81761A	4P-T Post			
VR105	OB32129A	Semi VR 50K	R179,180	OB09701A	RK 10K 1/6W J	R321L,R	OB24213A	RF 3.3 1/4W J	C169	OB05796A	CML 0.047μ 50V J	CN24	OB81761A	4P-T Post			
VR301,302	OB32126A	Semi VR 5K	R181	OB09725A	RK 100K 1/6W J	R322L,R	OB24213A	RF 3.3 1/4W J	C170	OB01405A	CE 1μ 50V	CN27	OB81763A	6P-T Post			
R100	OB09681A	RK 1.5K 1/6W J			(TA-2 (Other))	R323L,R	OB24212A	RF 10 1/2W J	C171,172	OB01674A	CE 10μ 25V	CN29	OB81763A	6P-T Post			
R101	OB09665A	RK 330 1/6W J	R182	OB05560A	RK 18K 1/4W J	R324L,R	OB24206A	RC 1 5W	C173	OB01405A	CE 1μ 50V	CN31	OB83506A	Ter. Grip Ass'y			

7. SCHEMATIC DIAGRAMS

7.1. IC Block Diagrams

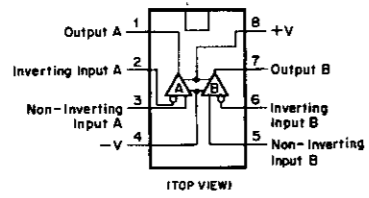

Fig. 7.1.1 Operational Amp. IC NJM2043DD

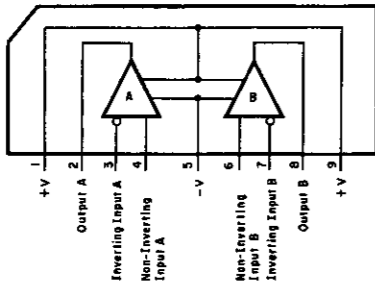

Fig. 7.1.2 Operational Amp. IC NJM4558S, μPC4570HA

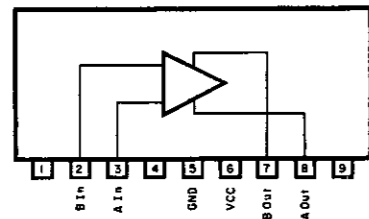

Fig. 7.1.3 Volume Motor Driver IC BA6208

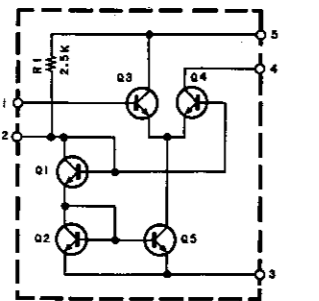

Fig. 7.1.4 FM IF Amp. IC TA7060AP

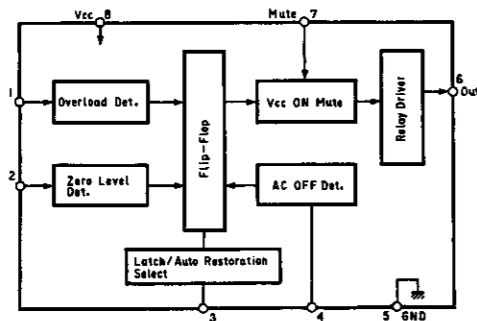

Fig. 7.1.5 Power Amp. Protector IC μPC1237H

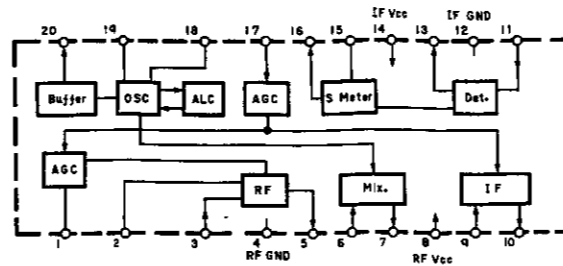

Fig. 7.1.6 AM Tuner IC LA1247

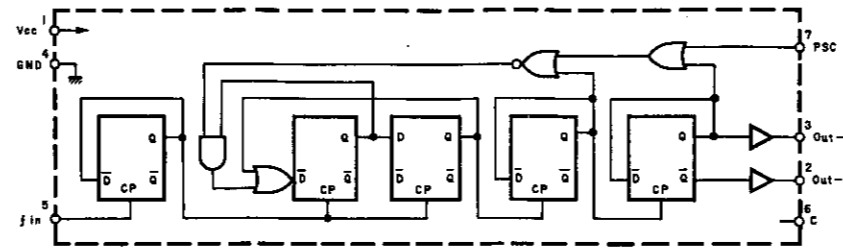

Fig. 7.1.7 ECL Prescaler (FM) IC TD6104P

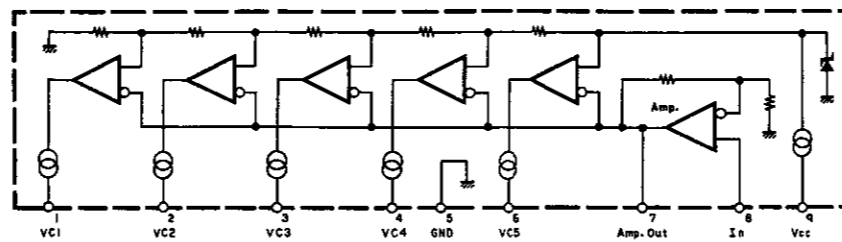

Fig. 7.1.8 Signal Meter Driver IC LB1413N

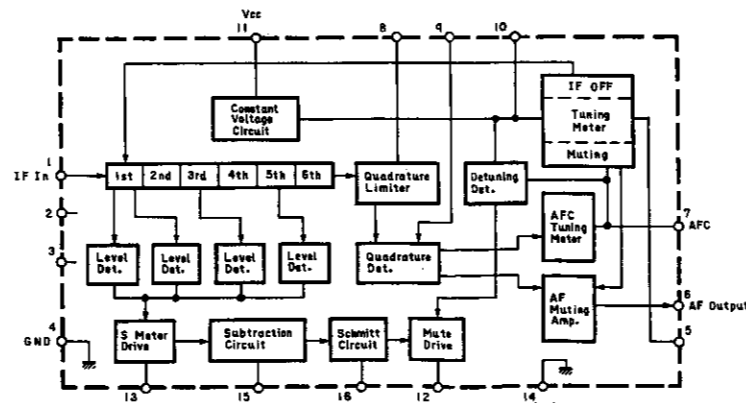

Fig. 7.1.9 FM IF Amp. & Detector IC LA1285

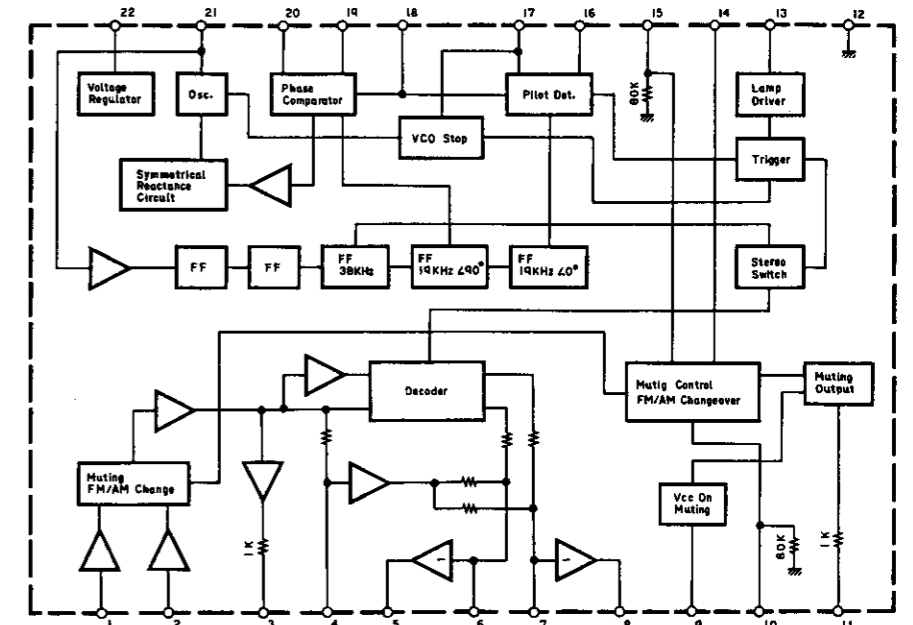

Fig. 7.1.10 PLL FM MPX Demodulator IC LA3400N

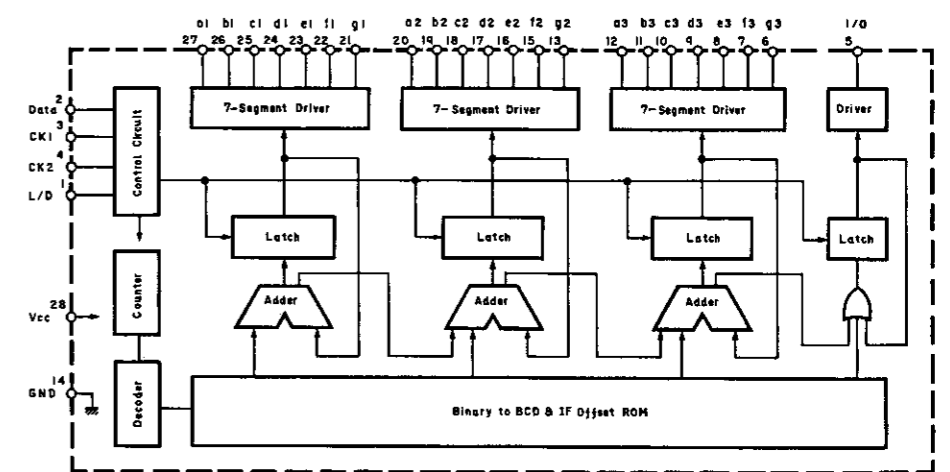
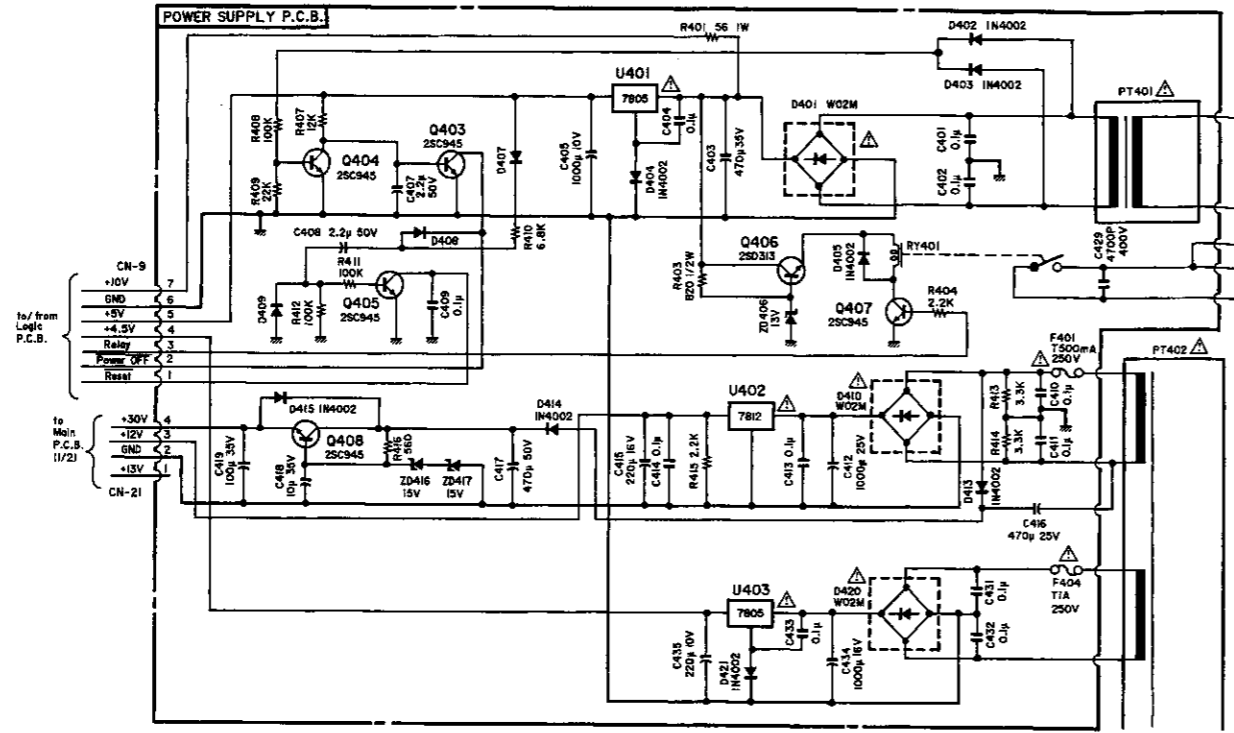
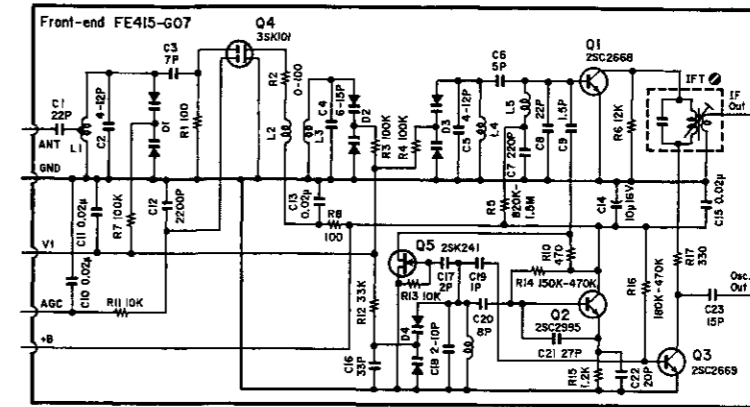

Fig. 7.1.11 Display Driver IC TD6301AP

7.2. Schematic Diagrams



Power Supply P.C.B. Assy for TA-2 (Other)



FM Front-end for TA-2E

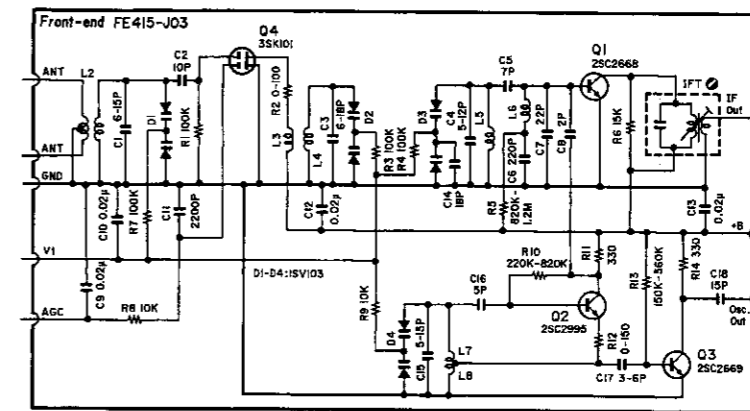

FM Front-end for TA-20

7.2.1. Tuner Section

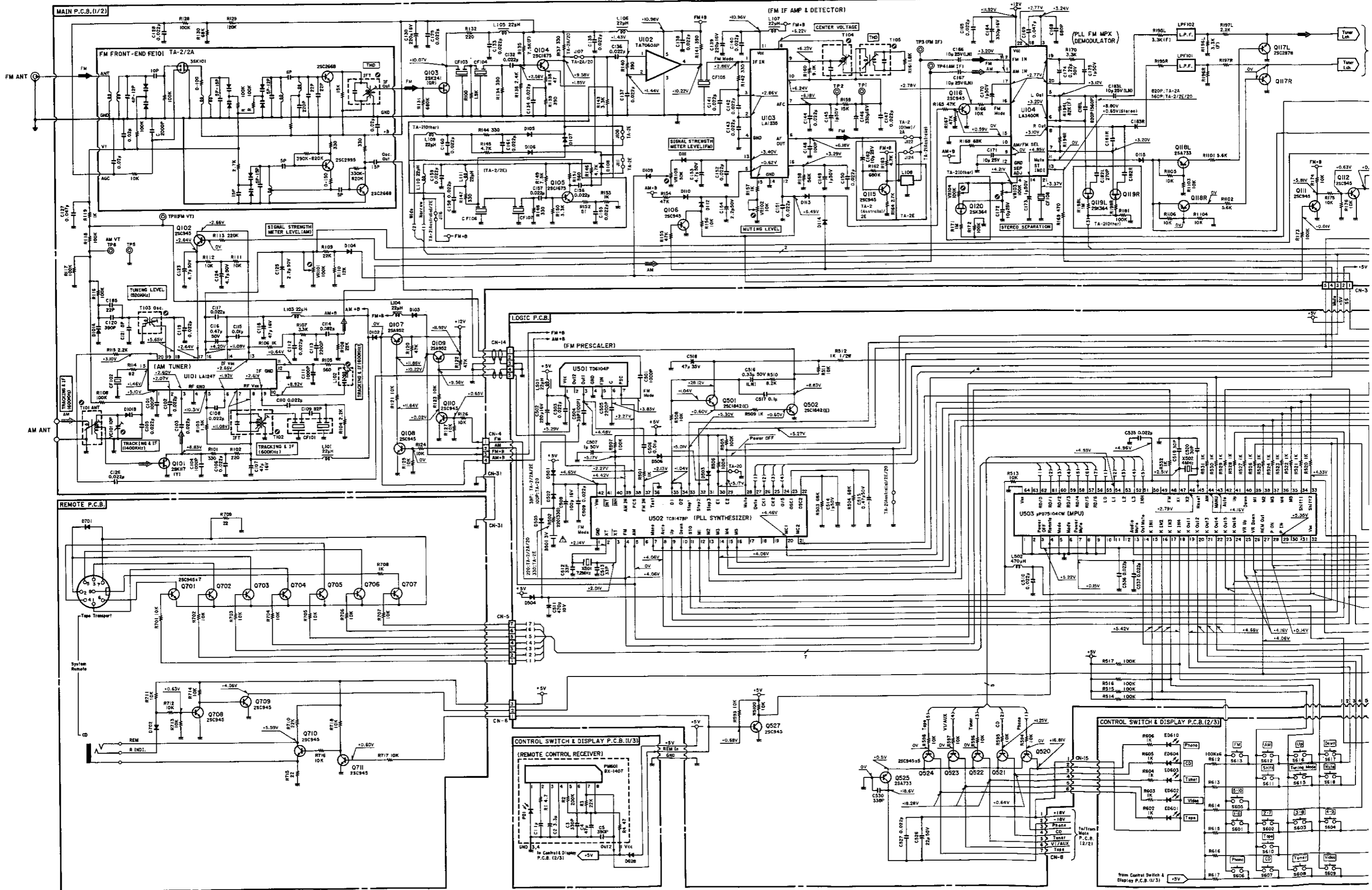
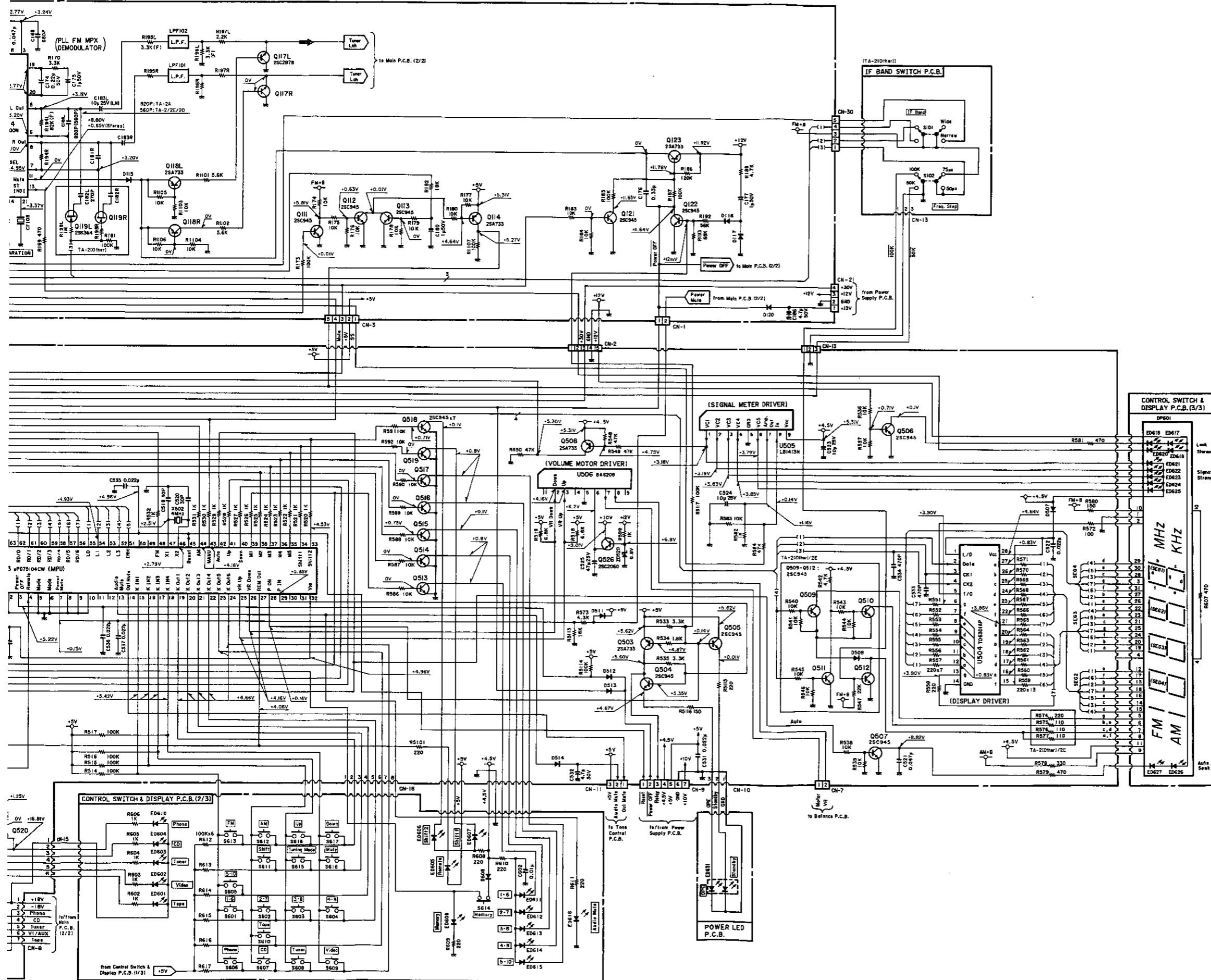

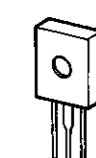



Fig. 7.2.1



- 

 2SA733
 2SA952
 2SA953
 2SA970
 2SC945
 2SC1675
 2SC1842
 2SC2002
 2SC2240
 2SC2878
- 

 2SC2060
- 

 2SB772
- 

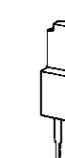
 2SA1491
 2SC3855
- 

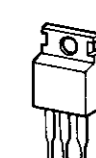
 2SB1016
 2SD1407
- 

 2SB507
 2SD313
- 

 2SK117
 2SK364
- 

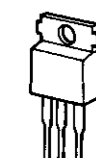
 2SK241
- 

 1N (V) GND OUT
 1PC7805H
 1PC7812H

Fig. 7.2.1

7.2.2. Amplifier Section

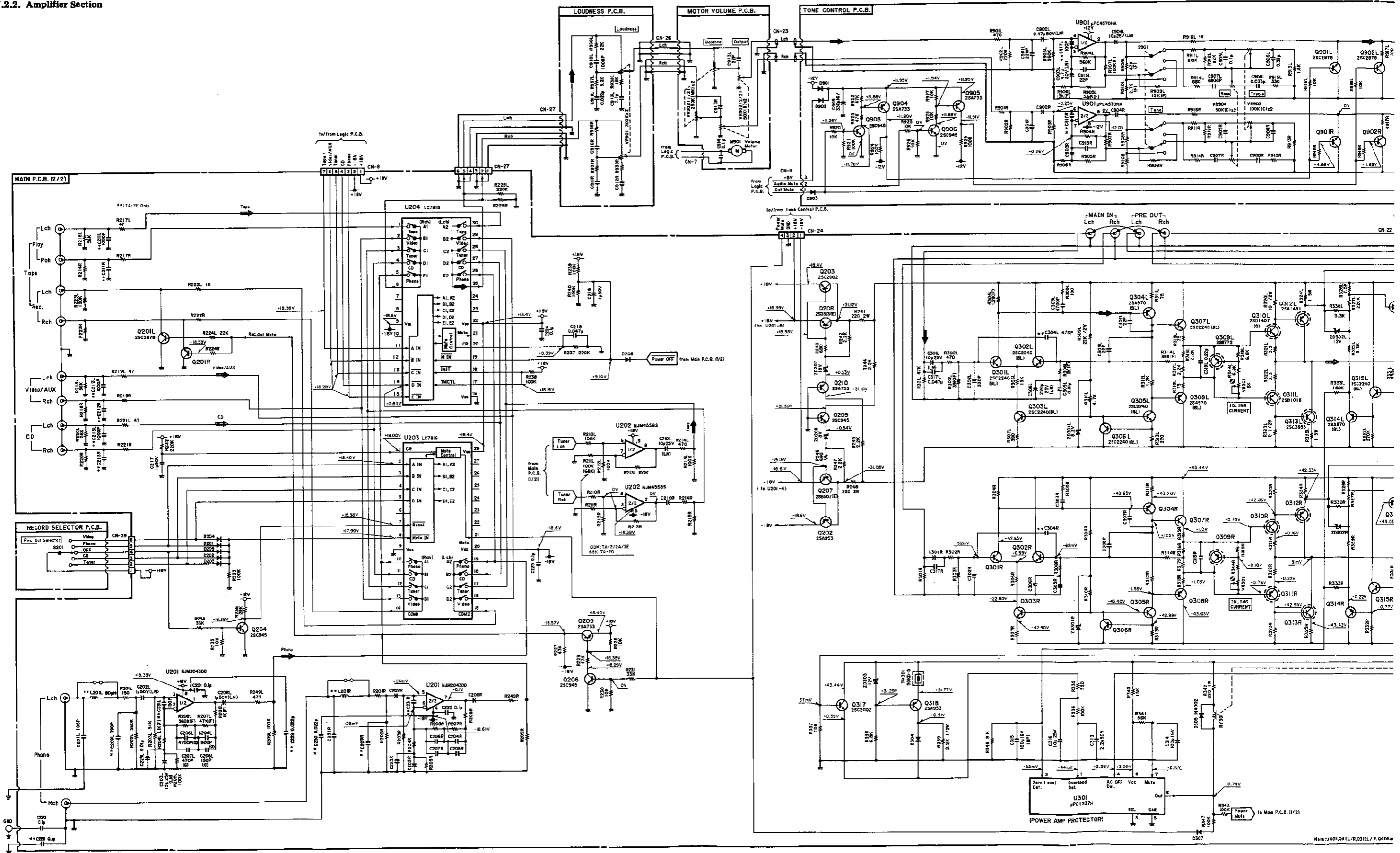

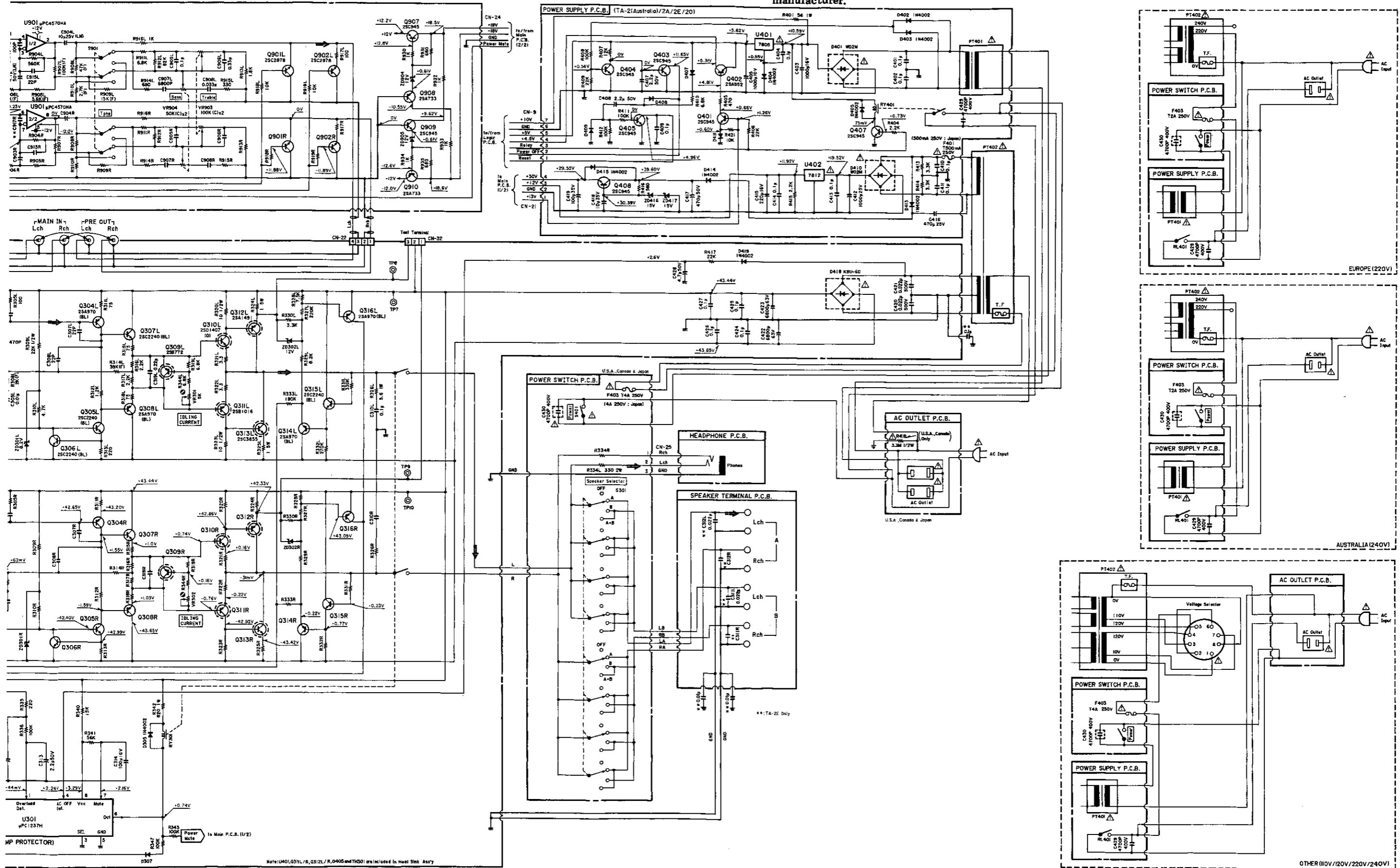

Fig. 7.2.2

WARNING:
 Parts marked with the symbol  have critical characteristics.
 Use **ONLY** replacement parts recommended by the manufacturer.

It is recommended that the unit be operated from a suitable DC supply or batteries during initial check-out procedures.



8. WIRING DIAGRAM

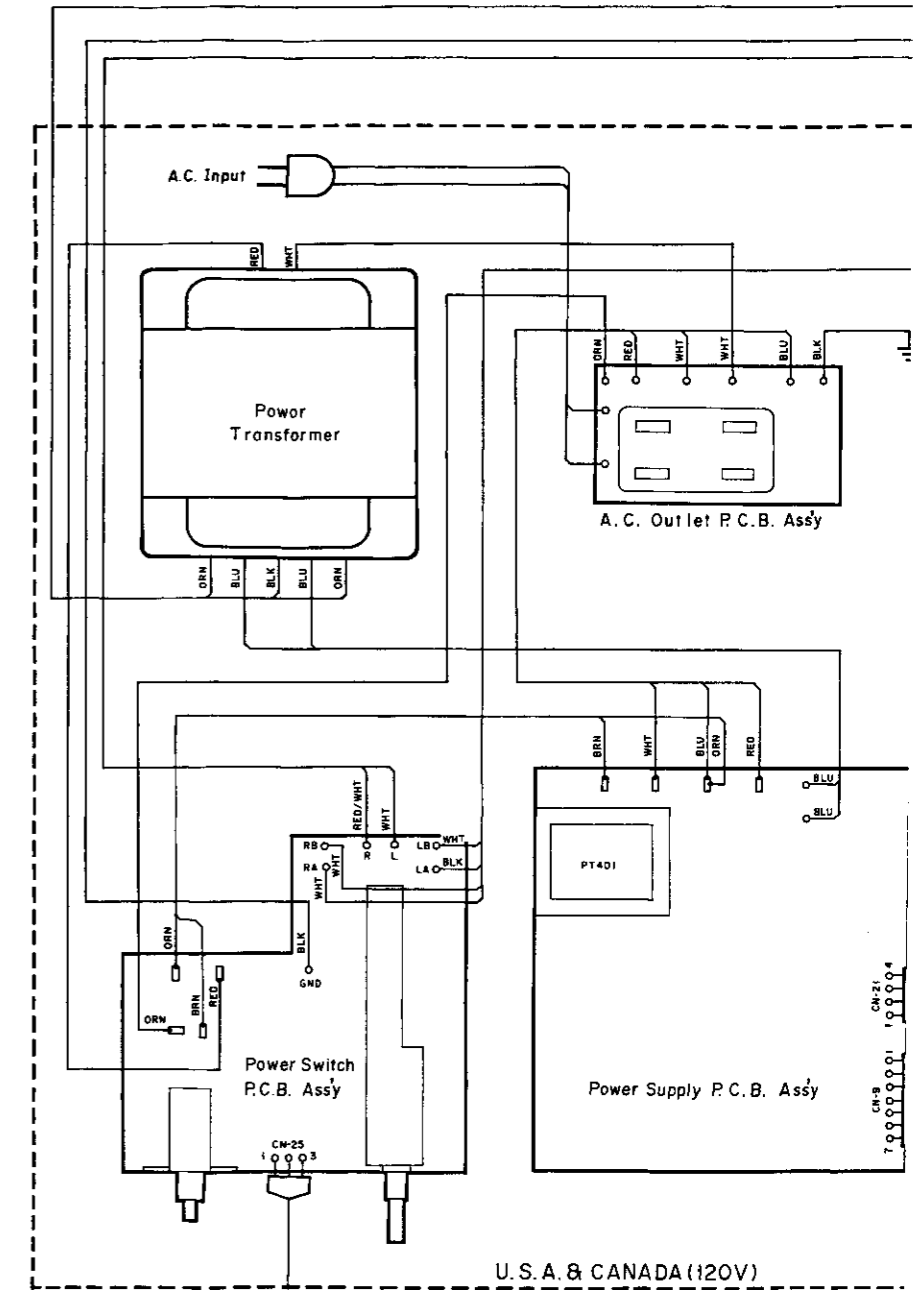
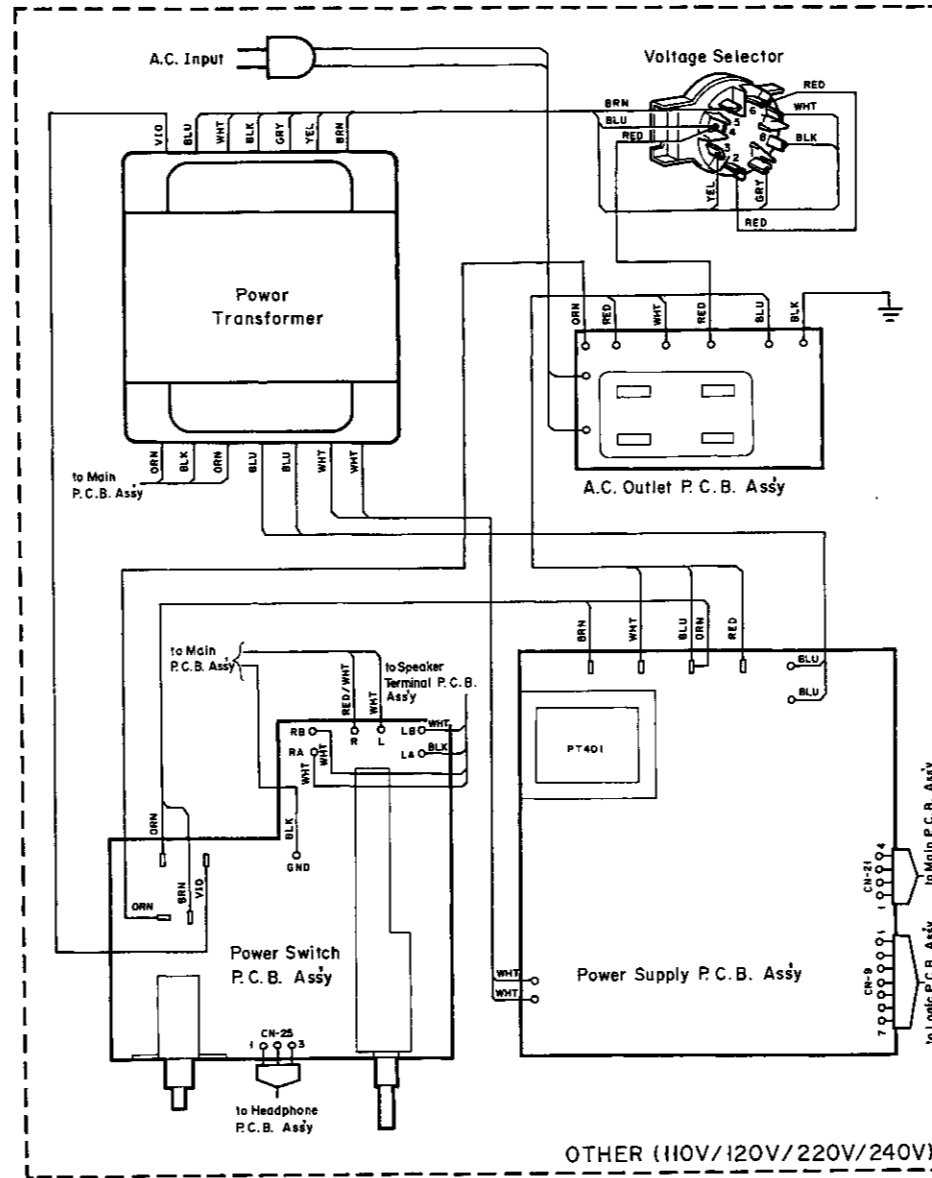
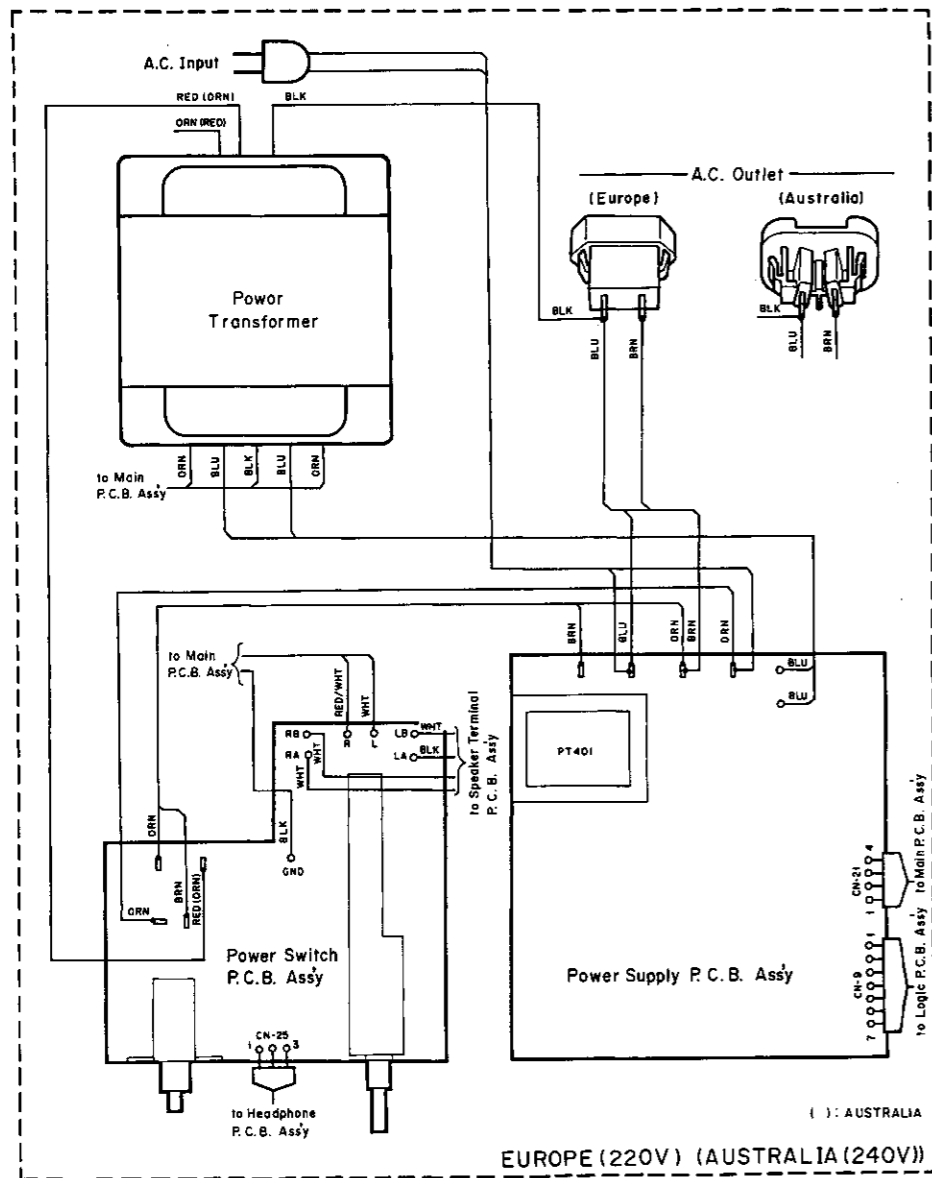

- Notes: 1. Table of wire colors
- | | |
|--------------|--------------|
| BRN - Brown | BLU - Blue |
| RED - Red | VIO - Violet |
| ORN - Orange | GRY - Gray |
| YEL - Yellow | WHT - White |
| GRN - Green | BLK - Black |
2. Component side view of the P.C.B. is illustrated unless otherwise specified.
3. Wire tube color is shown in ().

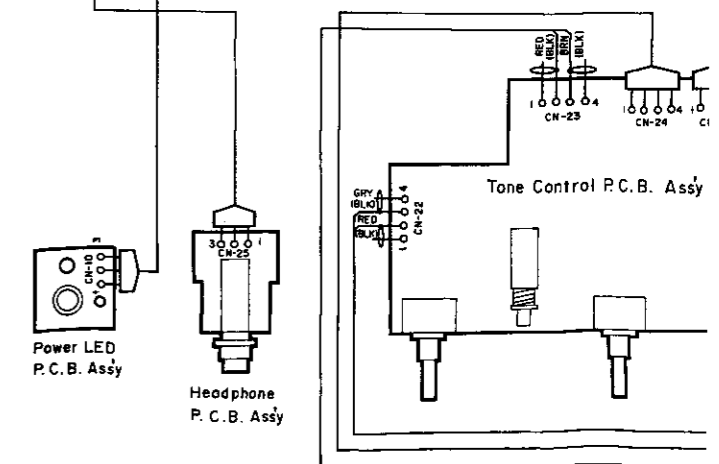

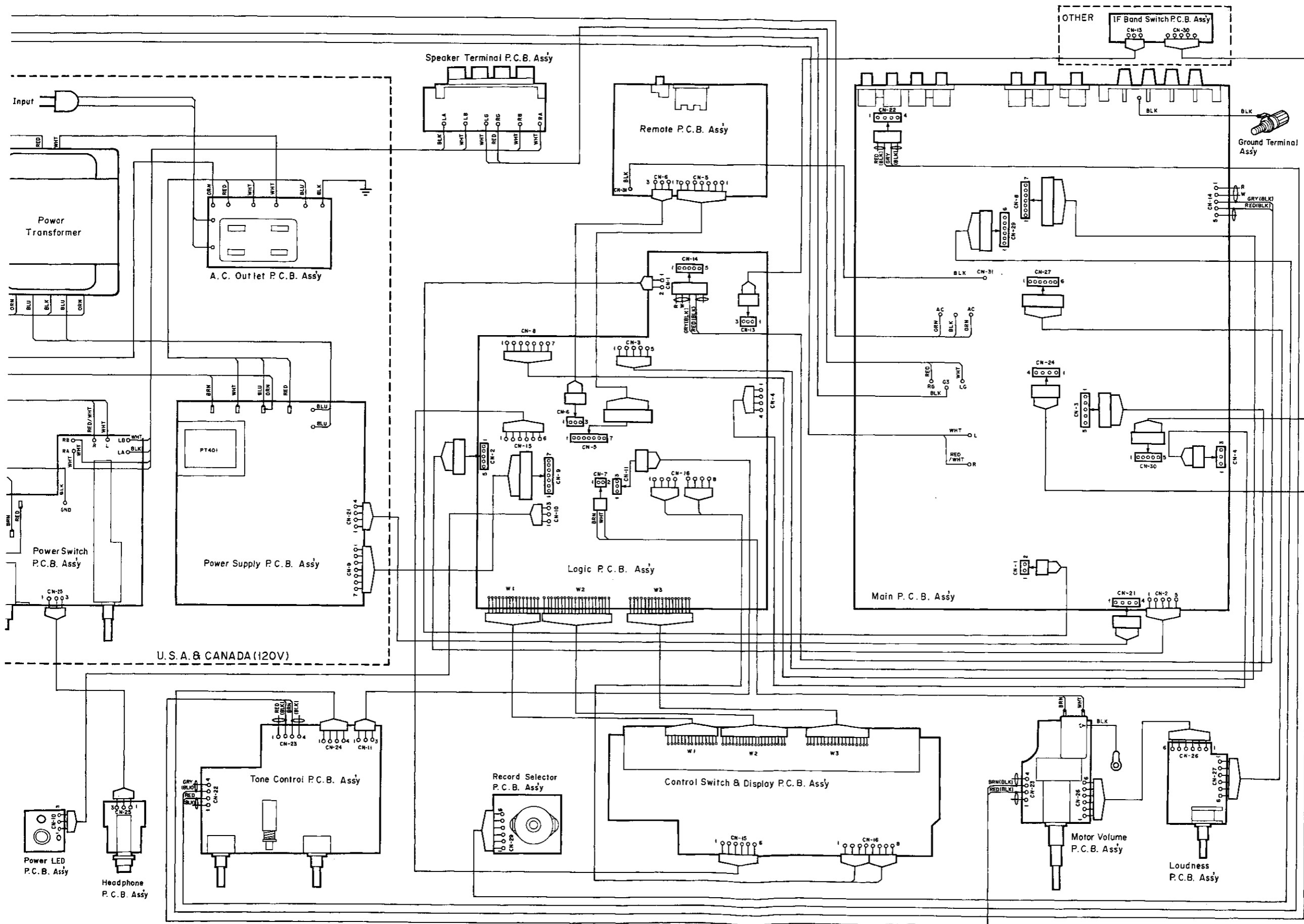

Fig. 8

9. BLOCK DIAGRAMS

9.1. Tuner Section

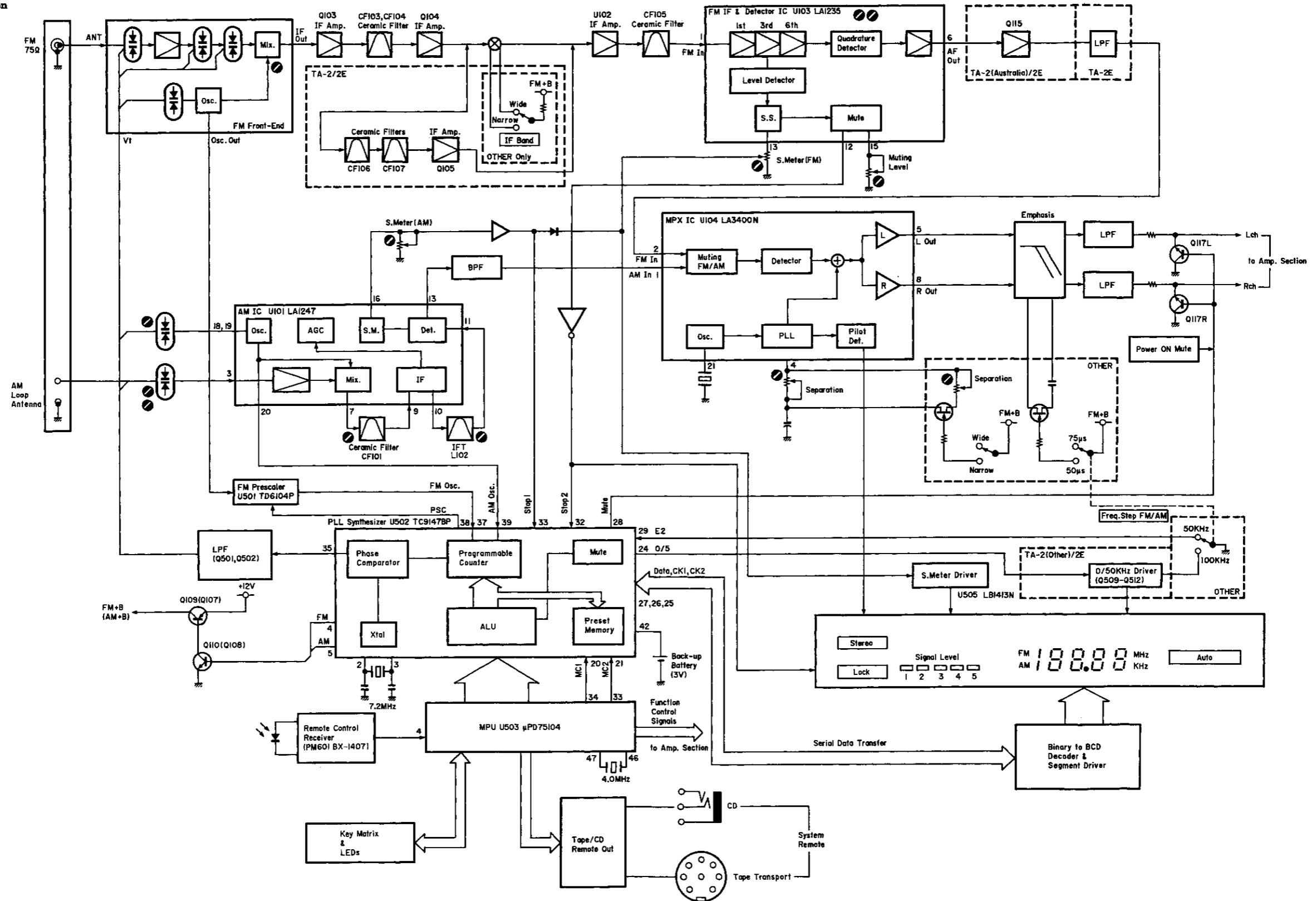

Fig. 9.1

9.2. Amplifier Section

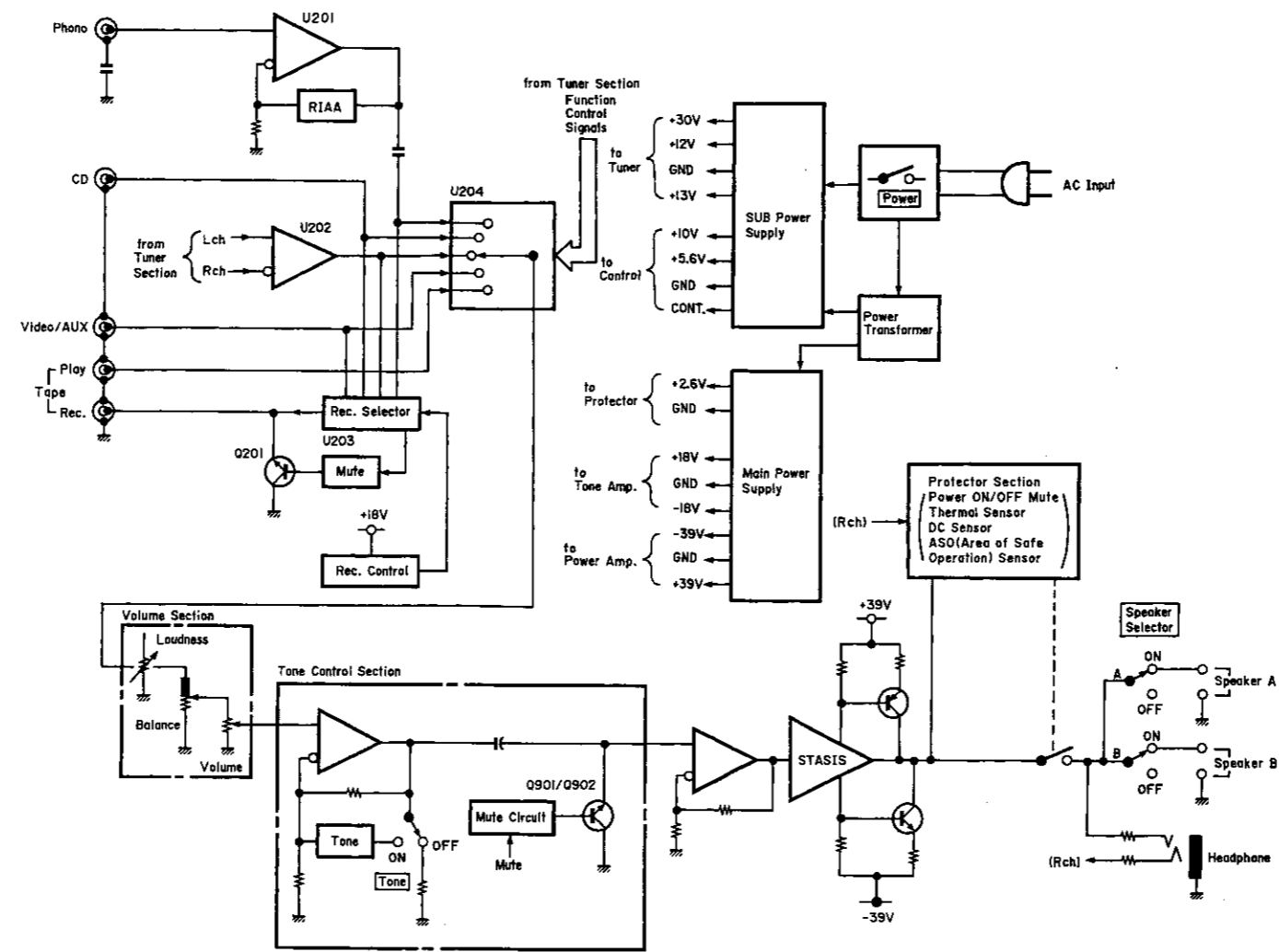

Fig. 9.2

10. SPECIFICATIONS

Power Amplifier Section

Note: Unless noted otherwise, specifications are in accordance with IHF-A-202 measured from any high-level input (CD/VIDEO/TAPE) to the speaker output.

Continuous Average Output Power	50 watts per channel into 8 ohms, both channels driven, 20–20,000 Hz, at no greater than 0.1% THD
Dynamic Output Power	66 watts per channel into 8 ohms 80 watts per channel into 4 ohms
Power Bandwidth	5–50,000 Hz 5–30,000 Hz (TA-2E)
Frequency Response	20–20,000 Hz; +0, –0.5 dB 20–20,000 Hz; +0, –1 dB (TA-2E) 5–75,000 Hz; +0, –3 dB 5–45,000 Hz; +0, –3 dB (TA-2E)
Signal to Noise Ratio (A-WTD, Input Shorted)	Better than 100 dB re Rated Power Better than 83 dB (IHF-A-202)
Total Harmonic Distortion (8 ohms, Rated Power, 20 Hz–20 kHz)	Less than 0.1%
Headphone Rated Output (40 ohms)	117 mW
Output Current Capability	14 A peak per channel

Preamplifier Section

Note: Unless noted otherwise, specifications are in accordance with IHF-A-202. Except for Sensitivity, S/N, Tone Control and Loudness characteristics (which are measured to the speaker outputs), measurements are made from the specified input to Rec. Out.

Sensitivity (for Rated Output)	
Phono MM	2.5 mV
CD/Tape/Video	150 mV
Main In	1.0 V
Sensitivity (for 1-watt output, IHF-A-202)	
Phono MM	0.35 mV
CD/Tape/Video	21 mV
Main In	141 mV
Input Impedance	
Phono MM	47 kohms
CD/Tape/Video	20 kohms
Main In	20 kohms
Maximum Input Level (1 kHz)	
Phono MM	180 mV
Pre Output Level/Impedance	1.0 V/1 kohms
Record Output Level/Impedance	150 mV/1.5 kohms
Total Harmonic Distortion (1 kHz, to Rec. Out, at 1 V)	
Phono MM	Less than 0.01%
RIAA Deviation	
Phono MM	30–20,000 Hz ±0.5 dB
Signal to Noise Ratio (to speaker output, IHF-A-202)	
Phono MM	Better than 78 dB Better than 76 dB (TA-2E)
Tone Controls	
Bass	20 Hz, ±10 dB
Treble	20 kHz, ±10 dB
Variable Loudness (re maximum attenuation: –40 dB at 1 kHz)	20 Hz, +20 dB; 20 kHz, +6 dB

Tuner Section

(1) TA-2 (Other) (See Note) & TA-2A

Note: Selector switch settings for Other Model

Frequency Step FM/AM: 100 kHz/10 kHz, De-emphasis: 75 μ s, IF Band: Wide

[FM Section]

Note: All RF levels in microvolts given re 300-ohm antenna input.

Modulation: Mono 100%, Stereo Pilot 9%, Stereo Audio Signal 91%.

All measurements made at Rec. Out Jack.

Frequency Range	87.5—108.0 MHz in 100 kHz steps
IHF Usable Sensitivity	12.0 dBf/2.2 μ V
(Mono)	
50-dB Quieting Sensitivity	
Mono	15.7 dBf/3.3 μ V
Stereo	38.5 dBf/46.1 μ V
Signal to Noise Ratio at 65 dBf	
Mono	Better than 79 dB
Stereo	Better than 74 dB
Muting Threshold	30 dBf/17.3 μ V
Frequency Response	20—15,000 Hz \pm 1 dB
Total Harmonic Distortion (1 kHz)	
Mono	Less than 0.10%
Stereo	Less than 0.10%
Capture Ratio	2.0 dB
Alternate Channel Selectivity . .	55 dB (\pm 400 kHz)
Stereo Separation at 1 kHz	Better than 50 dB
Spurious Response Rejection . .	Better than 90 dB
Image Rejection	Better than 75 dB
IF Rejection	Better than 80 dB
AM Suppression	Better than 60 dB

[AM Section]

Note: Modulation — 400 Hz, 30%

Frequency Range	520—1,710 kHz in 10 kHz steps
Sensitivity	53 dB μ /m
Signal to Noise Ratio at 90	Better than 52 dB
dB μ /m	
Total Harmonic Distortion	Less than 0.5%
at 90 dB μ /m	
Selectivity	Better than 20 dB (\pm 10 kHz)

(2) TA-2 (Other) (See Note) & TA-2E

Note: Selector switch settings for Other Model

Frequency Step FM/AM: 50 kHz/9 kHz, De-emphasis: 50 μ s, IF Band: Narrow

[FM Section]

Note: All RF levels in microvolts given re 300-ohm antenna input.

Modulation: Mono 60%, Stereo Pilot 9%, Stereo Audio Signal 51%.

All measurements made at Rec. Out Jack.

Frequency Range	87.50—108.00 MHz in 50 kHz steps
IHF Usable Sensitivity (Mono)	12.0 dBf/2.2 μ V
50-dB Quieting Sensitivity	
Mono	23.0 dBf/7.7 μ V (TA-2E), 24.0 dBf/8.8 μ V (TA-2 (Other))
Stereo	44.0 dBf/86.8 μ V (TA-2E), 45.0 dBf/97.4 μ V (TA-2 (Other))
Signal to Noise Ratio at 65 dBf	
Mono	Better than 72 dB (TA-2E)/75 dB (TA-2 (Other))
Stereo	Better than 67 dB
Muting Threshold	30 dBf/17.3 μ V
Frequency Response	20—15,000 Hz \pm 1 dB
Total Harmonic Distortion (1 kHz)	
Mono	Less than 0.20%
Stereo	Less than 0.25%
Capture Ratio	2.0 dB
Alternate Channel Selectivity	70 dB (\pm 300 kHz)
Stereo Separation at 1 kHz	Better than 40 dB
Spurious Response Rejection	Better than 90 dB
Image Rejection	Better than 75 dB
IF Rejection	Better than 80 dB
AM Suppression	Better than 60 dB

[AM Section]

Note: Modulation — 400 Hz, 30%

Frequency Range	522—1,611 kHz in 9 kHz steps
Sensitivity	53 dB μ /m
Signal to Noise Ratio at 90	Better than 52 dB
dB μ /m	
Total Harmonic Distortion	Less than 0.5%
at 90 dB μ /m	
Selectivity	Better than 20 dB (\pm 9 kHz)

General

Power Source	120, 220, 240 or 110/120/220/240 V AC, 50/60 Hz (According to country of sale)
Power Consumption	290 watts max.
Convenience Outlets	Switched: 2 (For TA-2 (Other) & TA-2A), Switched: 1 (TA-2E)
Dimensions	430 (W) x 100 (H) x 370 (D) mm 16-15/16 (W) x 3-15/16 (H) x 14-9/16 (D) inches
Approximate Weight	8.6 kg, 18 lbs, 15 oz.

Remote Control Unit (RM-2TA)

Principle	Infrared Pulse System
Power Supply	3 V DC (1.5 V x 2)
Dimensions	64 (W) x 18 (H) x 176 (D) mm 2-1/2 (W) x 11/16 (H) x 6-15/16 (D) inches
Approximate Weight	140 g, 5 oz. (including batteries)

- Specifications and design are subject to change for further improvement without notice.
- STASIS manufactured under license from Threshold Corporation.
- STASIS is a trademark of Threshold Corporation.

Service Manual

Nakamichi

TA-2, TA-2A, TA-2E, TA-20

Nakamichi Corporation/Tokyo Office
Nakamichi America Corporation
Nakamichi Canada
Nakamichi GmbH
Nakamichi Australia

Shinjuku Daiichi Seimei Bldg., 2-7-1 Nishishinjuku, Shinjuku-ku, Tokyo 163 Phone: (03) 342-4461 Telex: 2324721 (NAKAM J)
19701 South Vermont Ave., Torrance, CA 90502 Phone: (213) 538-8150
276 South West, Marine Drive, Vancouver, B.C. V5X 2R4 Phone: (604) 324-7535
Stephanienstraße 6, 4000 Düsseldorf 1 Phone: (0211) 359036
Unit 10, 21-29 Chester Street, Camperdown, N.S.W. 2050 Phone: (02) 519-3977

Service Information



Model TA-2/2A/2E/20 (High Definition Tuner Amplifer)

Serial No. from D10851601 -

Subject Change of Transistor

No. OOD-M-0338 (1/1)

Date 8 February 1990

1. General

1.1. Purpose

To obtain greater power margin (collector dissipation), Q525 on the Logic P.C.B. Ass'y has been changed.

If you receive a complaint about transistor damage from your customer, we recommend you to change the damaged transistor to a new one having greater power margin.

1.2. Modification

Refer to Fig. 1.

Q525 on the Logic P.C.B. Ass'y has been changed as follows:

<u>Ref. No.</u>	<u>Current Part No.</u>	<u>Current Description</u>	<u>New Part No.</u>	<u>New Description</u>	<u>Q'ty</u>
Q525	0B06013A	TR 2SA733	0B06372A	TR 2SA953	1

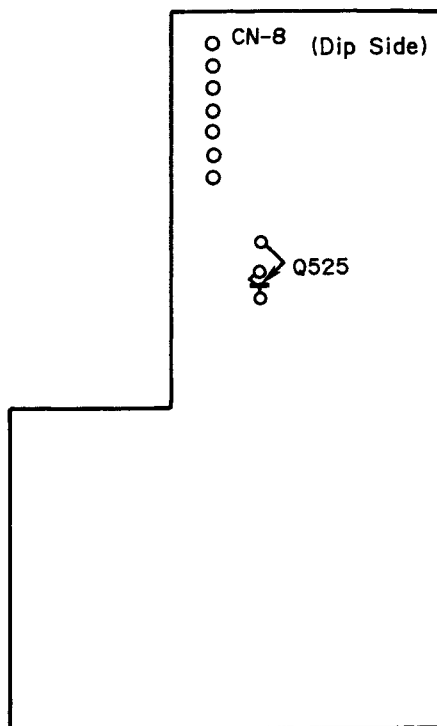

Note: See Fig. 6.14 (page 18) in the Service Manual.

Fig. 1 (Logic P.C.B. Ass'y)