



Service Manual

Nakamichi

TA-3
TA-3A
TA-3E
TA-30

High Definition Tuner Amplifier



CONTENTS

1.	General	1
2.	Removal Procedures	3
2. 1.	Top Cover Ass'y and Bottom Cover Ass'y	3
2. 2.	Front Panel	3
2. 3.	Power Switch P.C.B. Ass'y	3
3.	Parts Location for Electrical Adjustment	4
4.	Electrical Adjustments	5
4. 1.	Power Amplifier Section	5
4. 2.	Tuner Section	5
4.2.1.	FM Tuner Section	5
4.2.2.	AM Tuner Section	7
5.	Mechanism Ass'y and Parts List	8
5. 1.	Synthesis	8
5. 2.	Chassis Ass'y (A01)	9
5. 3.	Heat Sink Ass'y (B01)	11
5. 4.	Front Chassis Ass'y (B02)	11
6.	Mounting Diagrams and Parts List	12
6. 1.	AC Outlet P.C.B. Ass'y	12
6. 2.	Power Switch P.C.B. Ass'y	12
6. 3.	Speaker Terminal P.C.B. Ass'y	12
6. 4.	Headphone P.C.B. Ass'y	13
6. 5.	Power LED P.C.B. Ass'y	13
6. 6.	Volume LED P.C.B. Ass'y	13
6. 7.	Subsonic P.C.B. Ass'y	13
6. 8.	Phono Input P.C.B. Ass'y	13
6. 9.	Record Selector P.C.B. Ass'y	13
6. 10.	Loudness P.C.B. Ass'y	13
6. 11.	Motor Volume P.C.B. Ass'y	14
6. 12.	IF Band Switch P.C.B. Ass'y	14
6. 13.	Tone Control P.C.B. Ass'y	14
6. 14.	Power Supply P.C.B. Ass'y	15
6. 15.	Control Switch & Display P.C.B. Ass'y	16
6. 16.	Video P.C.B. Ass'y	17
6. 17.	Logic P.C.B. Ass'y	20
6. 18.	Main P.C.B. Ass'y	21
7.	Schematic Diagrams	23
7. 1.	IC Block Diagrams	23
7. 2.	Schematic Diagrams	24
7.2.1.	Video Section	24
7.2.2.	Tuner Section	25
7.2.3.	Amplifier Section	26
8.	Wiring Diagram	27
9.	Block Diagrams	28
9. 1.	Tuner Section	28
9. 2.	Amplifier Section	29
10.	Specifications	30

1. GENERAL

1.1. CAUTIONS/WARNINGS

(1) Product Safety Notice

Parts marked with the symbol  in the schematic diagram have critical characteristics.

Use ONLY replacement parts recommended by the manufacturer.

It is recommended that the unit be operated from a suitable DC supply or batteries during initial check-out procedures.

(2) Leakage Current Check/Resistance Check

Before returning the unit to the customer, make sure you make either (1) a leakage current check or (2) a line to chassis resistance check. If the leakage current exceeds 0.5 milliamp, or if the resistance from chassis to either

side of the power cord is less than 240 k ohms, the unit is defective.

WARNING — DO NOT return the unit to the customer until the problem is located and corrected.

(3) Lithium Battery Caution

Use ONLY replacement parts recommended by the manufacturer. Replacement must be done only by qualified service personnel because of risk for explosion.

WARNING

Litiumbatteri. Explosionsfara vid felaktig hantering. Byte får endast ske av sakkunnig personal enligt servicedokumentationens anvisningar.

ADVARSEL!

Lithiumbatterier. Eksplosionsfare. Udskiftning må kun foretages af en sagkyndig og som beskrevet i servicemanualen.

batterierne kun må udskiftes med batterier af samme fabrikat og type.

1.2. Destination

- TA-3: Other & Australia
- TA-3A: U.S.A. & Canada
- TA-3E: Europe
- TA-30: Japan

1.3. Voltage Selector

Voltage selector is installed on the rear panel for Other version of the TA-3.

This voltage selector can select 110, 120, 220, or 240 V at customer's disposal.

1.5. Accessory Ass'y

1.4. Package Ass'y

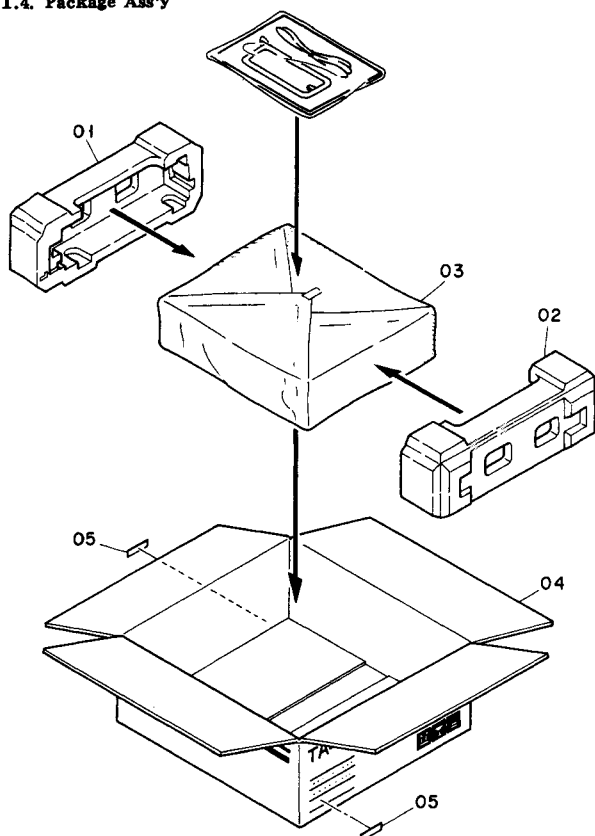

Fig. 1.1

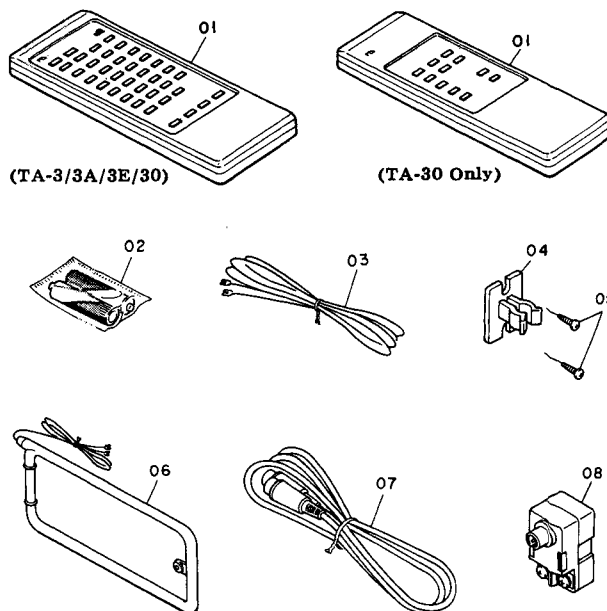

Fig. 1.2

Schematic Ref. No.	Part No.	Description	Q'ty	Schematic Ref. No.	Part No.	Description	Q'ty
		Package Ass'y				Accessory Ass'y	
01	OF04141B	Packing L (TA-3/3E/30)	1	01	DA04196A	Remote Control Unit	1
	OF04195A	Packing L (TA-3A)	1		DA04208A	Remote Control Unit (TA-30)	1
02	OF04042B	Packing R (TA-3/3E/30)	1	02	OB90242A	Battery AA Type x 2 (TA-3/3E)	1
	OF04196A	Packing R (TA-3A)	1		OB90341A	Battery AA Type x 2 (TA-3A)	1
03	OF03670A	Poly Sheet (TA-3/3E/30)	1		OB90276A	Battery UM 3x2 (TA-30)	2
	OF04199A	Soft Sheet (TA-3A)	1	03	OB90320A	Feeder Antenna	1
04	OF04193A	Carton Box (TA-3)	1	04	OB90319A	Loop Antenna Holder	1
	OF04191A	Carton Box (TA-3A)	1	05	OE03496A	Screw 3.1x10 @BLK (For Wood)	2
	OF04194A	Carton Box (TA-3E)	1	06	OB90318A	AM Loop Antenna	1
	OF04192A	Carton Box (TA-30)	1	07	OB83465A	8P DIN Cable	1
05	OM05280A	Serial No. Label (TA-3/3E/30)	1	08	OB90194A	Antenna Adapter F (TA-3/3A/30)	1
	OM05247A	Serial No. Label (TA-3A)	2		OB90208A	Antenna Adapter EP (TA-3E)	1
-	OF04218A	Rear Spacer Packing (TA-3/3E/30)	1	-	OD04810A	Important Notice	1
	OM03457A	Voltage Label 240V (TA-3 (Australia))	2	-	OD04836C	Warranty Card (TA-3A)	1
				-	OD04872D	Owner's Manual (English/German/French)	1
				-	OD04875A	Owner's Manual (Japanese)	1
				-	OD04212A	Poly Bag for Knob (TA-3/3E/30)	1
				-	OD03092B	Poly Bag for Accessory 320x340x0.08 (TA-3/3E/30)	1
				-	OD04903A	Poly Bag for Accessory 6x10 (TA-3A)	1
				-	OD04902A	Poly Bag for Set 22x40 (TA-3A)	1
				-	OJ05916A	Speaker Terminal Bush (TA-3E)	1

2. REMOVAL PROCEDURES

2.1. Top Cover Ass'y and Bottom Cover Ass'y

Refer to Fig. 2.1.

- (1) Loosen screws F01 (5 pcs.) and remove F02 (Top Cover Ass'y).
- (2) Loosen screws F03 (10 pcs.) and remove F04 (Bottom Cover Ass'y).
- (3) Loosen screws F05 (2 pcs.) and remove legs (F06) as required.

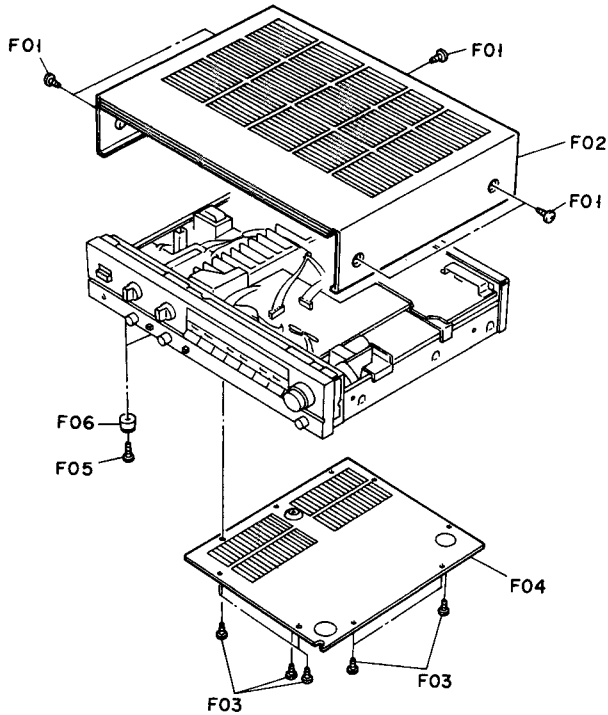

Fig. 2.1

2.2. Front Panel

Refer to Fig. 2.2.

- (1) Remove the Top Cover Ass'y and Bottom Cover Ass'y referring to item 2.1.
- (2) Loosen screws F01 (3 pcs.), F02 (2 pcs.) and F03 (3 pcs.), and remove F04 (Front Panel).

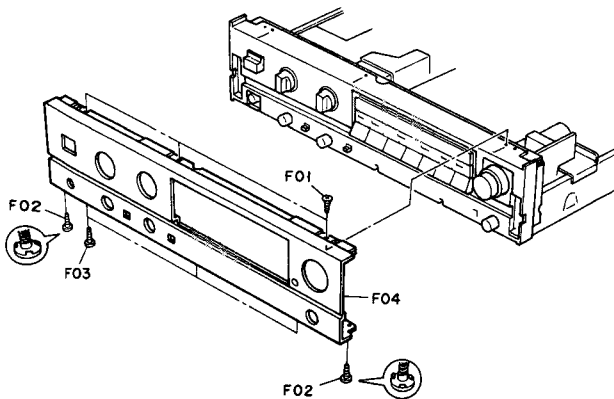

Fig. 2.2

2.3. Power Switch P.C.B. Ass'y

Refer to Figs. 2.3.1 and 2.3.2.

- (1) Remove the Top Cover Ass'y referring to item 2.1.
- (2) Pull out a knob F01, loosen a nut F02, and remove a washer F03.
- (3) Loosen screws F04 (2 pcs.) and remove a button F05. To remove F05, push the Power Switch rearward as shown in Fig. 2.3.2.
- (4) Remove F06 (Power Switch P.C.B. Ass'y).

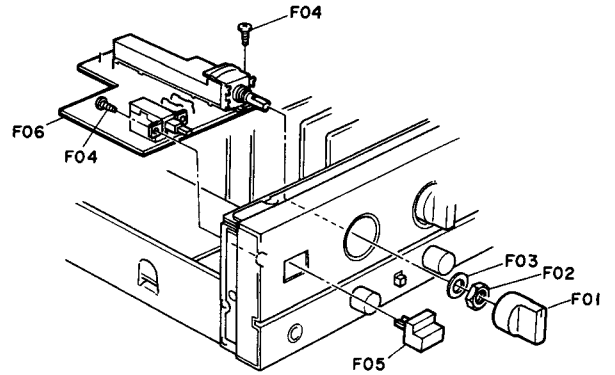

Fig. 2.3.1

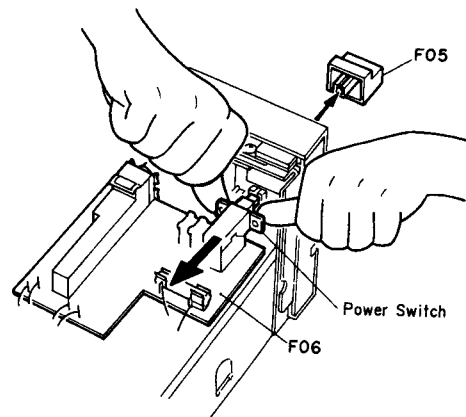

Fig. 2.3.2

3. PARTS LOCATION FOR ELECTRICAL ADJUSTMENT

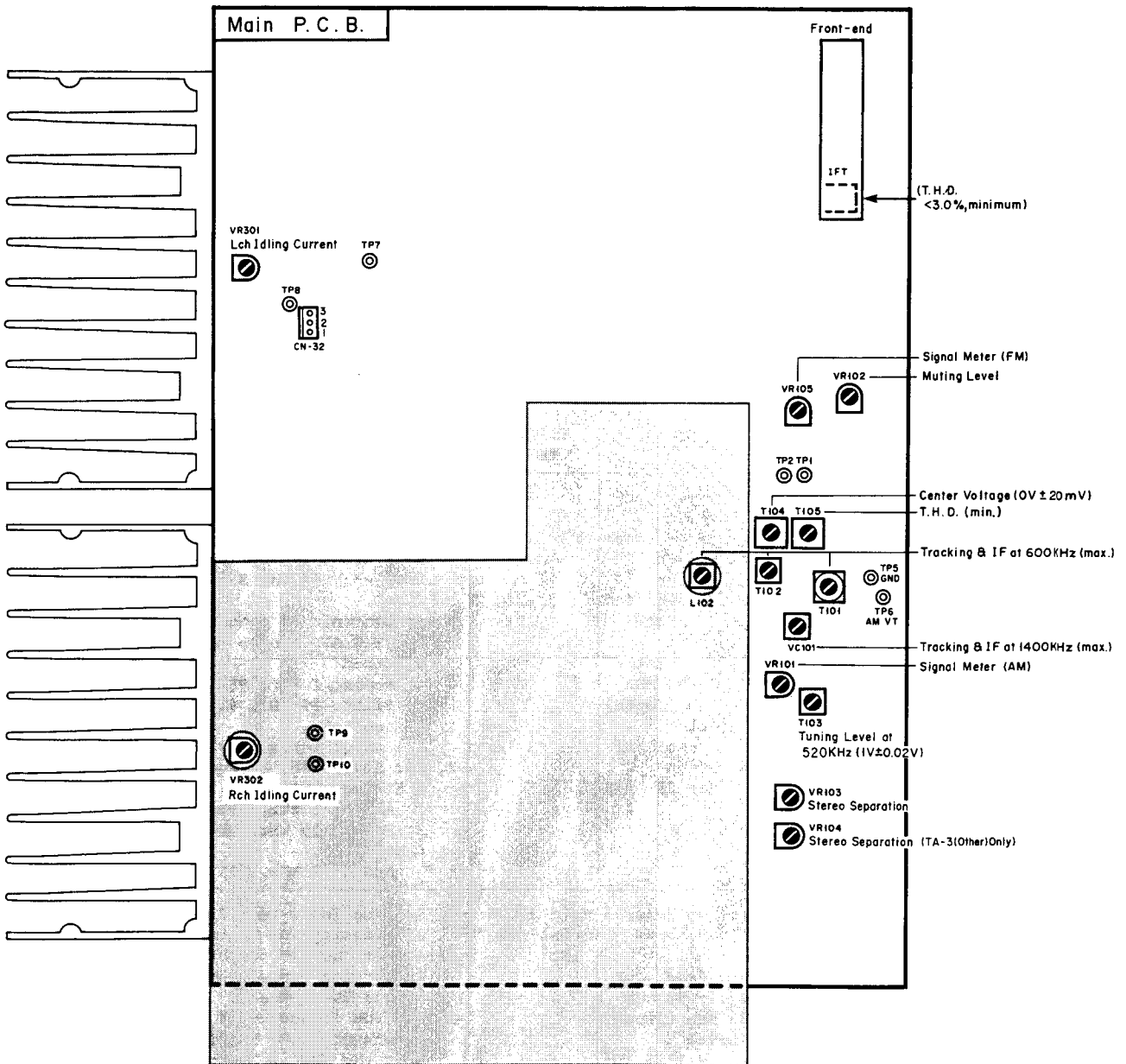

Fig. 3

4. ELECTRICAL ADJUSTMENTS

4.1. Power Amplifier Section

STEP	ITEM	SIGNAL SOURCE	OUTPUT CONNECTION	MODE	ADJUSTMENT	REMARKS
1	Idling Current	None	DC Voltmeter between TP7 & 8 (or CN32-2 & 3) and TP7 & CN32-1 on Main P.C.B.	Monitor Selector - CD Output Level - Min. Speaker Selector - OFF	Main P.C.B. VR301 VR302	<ol style="list-style-type: none"> 1. Insert shorting plugs into the CD Player Input Jacks. 2. Turn ON the power and allow 3 minutes before adjustment. (Top Cover must be installed in this period of time.) 3. Adjust VR301 (VR302) to obtain $25 \text{ mV} \pm 5 \text{ mV}$ on the DC voltmeter.

4.2. Tuner Section

Note: Adjustment should be made in a shielded room in principle.

4.2.1. FM Tuner Section

STEP	ITEM	OUTPUT CONNECTION	MODE	ADJUSTMENT	REMARKS
1	Preliminary Step	See Fig. 4.1	Tuner Amplifier Monitor Selector - Tuner Band Selector - FM Rec.out Selector - Tuner Signal Generator Freq. - 98 MHz - 83 MHz (Japan) RF Level - 65 dBf Modulation - See REMARKS		<ol style="list-style-type: none"> 1. Set the Tuner Amplifier as indicated in the MODE. 2. Adjustment and confirmation should be made after tuning in to the set carrier frequency of the Signal Generator. <p>Note: Contents of modulation</p> <ol style="list-style-type: none"> 1. For U.S.A., Canada, Other (Wide) & Japan <ul style="list-style-type: none"> o Stereo Audio: 1 kHz, 91% Pilot: 19 kHz, 9% o Mono Audio: 1 kHz, 100% 2. For Australia, Europe & Other (Narrow) <ul style="list-style-type: none"> o Stereo Audio: 1 kHz, 51% Pilot: 19 kHz, 9% o Mono Audio: 1 kHz, 60%
2	Usable Sensitivity Adjustment	Distortion Meter to Tape 1 Record Output Jacks	Tuner Amplifier Same as above Signal Generator Freq. - 98 MHz - 83 MHz (Japan) RF Level - 13.5 dBf Modulation - Mono	Main P.C.B. Front-end IFT	<ol style="list-style-type: none"> 1. Set the Tuner Amplifier to Manual mode by pressing the Tuning Mode button. 2. Adjust the IFT to obtain minimum distortion (total harmonic distortion (THD): 3% or less). 3. Set the frequency of the Signal Generator to 90 MHz/106 MHz and check that the THD is 3% or less.
3	Center Voltage and THD Adjustment	DC Voltmeter between TP1 & TP2 on Main P.C.B. and Distortion Meter to Tape 1 Record Output Jacks	Tuner Amplifier Same as above Signal Generator Freq. - 98 MHz - 83 MHz (Japan) RF Level - 65 dBf Modulation - Mono	Main P.C.B. T104 T105	<ol style="list-style-type: none"> 1. Set the Tuner Amplifier to Manual mode. 2. Adjust T104 so that the reading on the DC voltmeter is $0 \text{ V} \pm 20 \text{ mV}$. 3. Adjust T105 to obtain minimum distortion (THD: 0.05% or less). Repeat 2 and 3, if necessary.

STEP	ITEM	OUTPUT CONNECTION	MODE	ADJUSTMENT	REMARKS
4	Muting Level Adjustment	Oscilloscope to Tape 1 Record Output Jacks	Tuner Amplifier Same as above Signal Generator Freq. - 98 MHz - 83 MHz (Japan) RF Level - 30 dBf Modulation - Stereo	Main P.C.B. VR102	<ol style="list-style-type: none"> 1. Set the Tuner Amplifier to Auto mode. 2. Rotate VR102 fully counterclockwise. Then, return it clockwise gradually until a waveform appears on the oscilloscope. 3. Decrease the RF level of the Signal Generator until the waveform on the oscilloscope disappears. Then increase the RF level gradually until a waveform appears again. At this point, check that the RF level of the Signal Generator is 30 dBf \pm6 dB.
5	Signal Strength Meter Level Adjustment	None	Tuner Amplifier Same as above Signal Generator Freq. - 98 MHz - 83 MHz (Japan) RF Level - 56 dBf Modulation - Stereo	Main P.C.B. VR105	<ol style="list-style-type: none"> 1. Set the Tuner Amplifier to Auto mode. 2. Adjust VR105 so that all segments (1 - 5) of the signal strength meter light up. 3. Decrease the RF level of the Signal Generator to distinguish the segment 5. Next, increase it gradually so that the segment 5 starts illuminating. At this point, check that the RF level of the Signal Generator is 57 dBf \pm4 dB.
6	Stereo Separation Adjustment	AC Voltmeter to Tape 1 Record Output Jacks	Tuner Amplifier Same as above Signal Generator Freq. - 98 MHz - 83 MHz (Japan) RF Level - 65 dBf Modulation - L or R only	Main P.C.B. VR103 IF Band Switch P.C.B. VR104 (Other only)	<p>For U.S.A., Canada, Europe & Australia versions:</p> <ol style="list-style-type: none"> 1. Set the Tuner Amplifier to Auto mode. 2. Apply modulation to only L channel. 3. Adjust VR103 to obtain minimum reading on the AC voltmeter at the R channel output jack. 4. Apply modulation to only R channel. 5. Check that the reading on the AC voltmeter at the L channel output jack is within \pm1 dB with respect to the reading in 3. If not, repeat 2 through 4. <p>For Other version:</p> <ol style="list-style-type: none"> 1. Set the switches on the rear panel as follows: Freq. Step FM/AM - 100 kHz/10 kHz IF Band - Wide 2. Apply the same procedures as above. 3. Set the switches as follows: Freq. step FM/AM - 50 kHz/9 kHz IF Band - Narrow 4. Apply the same procedures as mentioned above. Adjust VR104 instead of VR103.

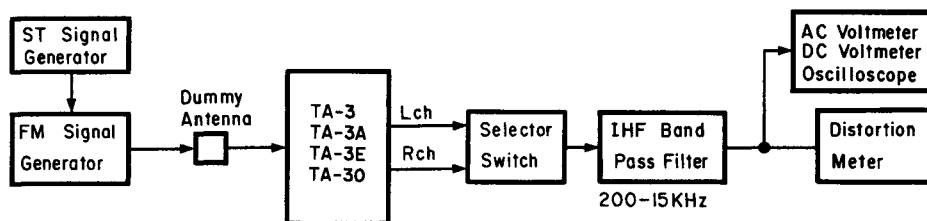

Fig. 4.1 FM Measuring Connection

4.2.2. AM Tuner Section

Note: Frequencies for Australia, Europe & Other (Narrow) are indicated in parentheses.

STEP	ITEM	OUTPUT CONNECTION	MODE	ADJUSTMENT	REMARKS
1	Tuning Level Adjustment	DC Voltmeter between TP6 and TP5 (GND) on Main P.C.B.	Tuner Amplifier Monitor Selector - Tuner Band Selector - AM Rec.out Selector - Tuner Signal Generator Freq. - 520 (522) kHz/ 1710 (1611) kHz Modulation - 400 Hz 30%	Main P.C.B. T103	1. Set the frequency of the Signal Generator to 520 kHz (522 kHz) and make tuning. 2. Adjust T103 to obtain 1 V \pm 0.02 V on the DC voltmeter. 3. Change the frequency to 1710 kHz (1611 kHz) and make tuning. Check whether the DC voltmeter reads 7.5 V to 8 V.
2	Tracking and IF Adjustment	AC Voltmeter to Tape 1 Record Output Jacks	Tuner Amplifier Same as above Signal Generator Freq. - 600 (603) kHz/ 1400 (1404) kHz RF Level - 82 dB μ Modulation - 400 Hz 30%	Main P.C.B. T101 T102 L102 VC101	1. Set the measurement instruments as shown in Fig. 4.2. Set the distance between the AM Loop Antenna of the TA-3/3A/3E/30 and a test loop to 60 cm. To obtain 56 dB μ /m at the AM Loop Antenna, set the RF level output of the AM Signal Generator to 82 dB μ as loss is 26 dB in this setting. 2. Set the frequency of the Signal Generator to 600 kHz (603 kHz) and make tuning. 3. Adjust T101 to obtain maximum reading on the AC voltmeter. 4. Adjust T102 to obtain maximum reading on the AC voltmeter. 5. Adjust L102 to obtain maximum reading on the AC voltmeter. 6. Set the frequency to 1400 kHz (1404 kHz) and make tuning. 7. Adjust VC101 to obtain maximum reading on the AC voltmeter. 8. Repeat 2 through 7 once.
3	Signal Strength Meter Level Adjustment	None	Tuner Amplifier Same as above Signal Generator Freq. - 1000 (999) kHz RF Level - 106 dB μ Modulation - 400 Hz 30%	Main P.C.B. VR101	1. With the same setting as in Step 2, set the RF level output of the AM Signal Generator to 106 dB μ in order to obtain 80 dB μ /m at the AM Loop Antenna. 2. Adjust VR101 so that the segment 5 of the signal strength meter starts illuminating. Note: Before adjustment, select AM mode and wait for more than three minutes.

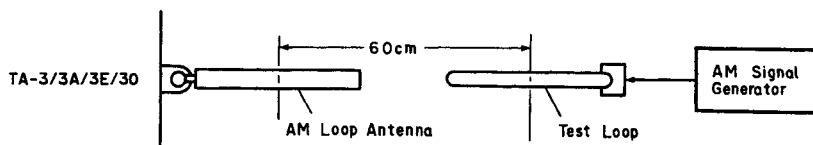

Fig. 4.2

5. MECHANISM ASS'Y AND PARTS LIST

5.1. Synthesis

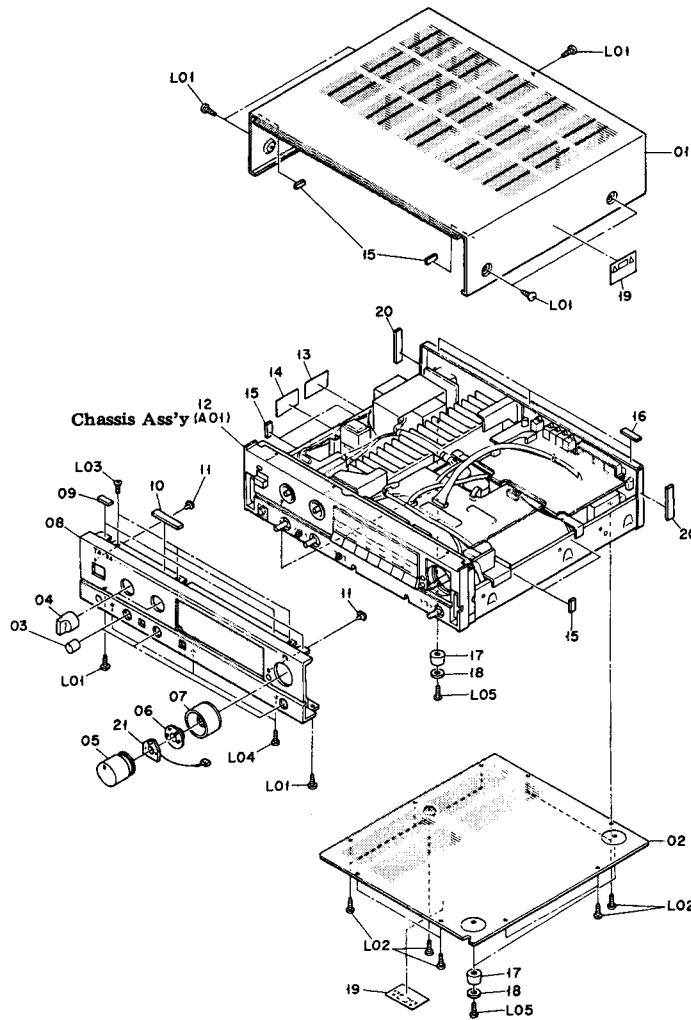

Fig. 5.1

Schematic Ref. No.	Part No.	Description	Q'ty	Schematic Ref. No.	Part No.	Description	Q'ty
5.1. Synthesis				17	0J05420A	Leg N (TA-3/3A/3E)	4
					0H05182A	Leg Ring (TA-30)	4
					0H05183A	Leg (TA-30)	4
01	0H05520A	Top Cover (TA-3/3E/30)	1	18	0J05461A	Leg Felt N (TA-3/3A/3E)	4
	0H05429A	Top Cover (TA-3A)	1		0J05428A	Leg Felt (TA-30)	4
02	0J05727A	Bottom Cover	1	19	0M04377B	Caution Label (TA-3A)	2
03	HA05540A	Tone Knob Ass'y	3	20	0J05850A	Top Cover Cushion	2
04	HA05539A	Selector Knob Ass'y	2	21	BA07440A	Volume LED P.C.B. Ass'y	1
05	HA05537A	Volume Knob Ass'y	1	L01	0E03433A	BT3x6 @ Binding Projected (Black Chromate)	7
06	0J05717A	LED Base	1	L02	0E00868A	BT3x8 @ Binding	10
07	HA05538A	Balance/Volume Ring Ass'y	1	L03	0E03054A	BT3x8 @ Countersunk	3
08	0H05404A	Front Panel (TA-3)	1	L04	0E00921A	BT3x8 @ Binding (Black Chromate)	3
	0H05402A	Front Panel (TA-3A)	1	L05	0E00888A	BT3x12 @ Binding	4
	0H05403A	Front Panel (TA-3E)	1	—	0M05280A	Serial No. Label (TA-3/3E/30)	1
	0H05405A	Front Panel (TA-30)	1	—	0M05247A	Serial No. Label (TA-3A)	1
09	0J05453A	Top Cover Sheet F	2	—	0M05267A	Fuse Label T2.5A 250V (TA-3 (Australia)/3E)	1
10	0J05754A	Top Cover Sheet FB	2				
11	0H05103A	LED Lens B	2				
12	—	Chassis Ass'y	1				
13	0M05289A	Fuse Caution Label T500mA 250V (TA-3A)	1				
14	0M05290A	Fuse Caution Label T5A 250V (TA-3A)	1				
15	0J05741A	Top Cover Spacer	6				
16	0J05740A	Top Cover Sheet R	3				

5.2. Chassis Ass'y (A01)

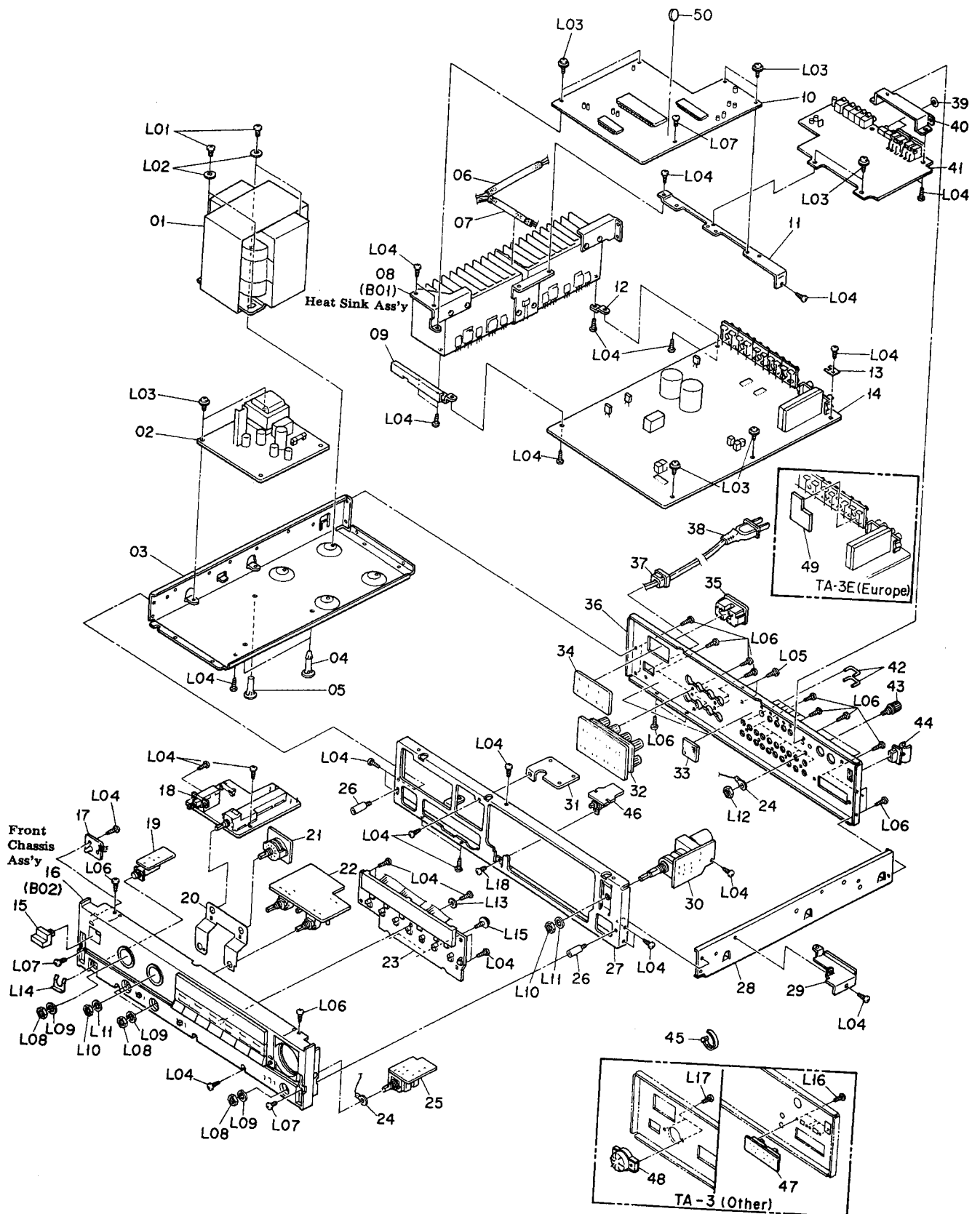

Fig. 5.2

Schematic Ref. No.	Part No.	Description	Qty	Schematic Ref. No.	Part No.	Description	Qty
5.2. Chassis Ass'y (A01)				37	OB90280A	Cord Bushing 2271	1
A01	—	Chassis Ass'y	1	38	OB80199A	AC Power Cord SPT-2 (TA-3 (Other)/3A)	1
01	OB50131A	Power Transformer (TA-3 (Other))	1		OB80148A	AC Power Cord (TA-3 (Australia))	1
	OB50129A	Power Transformer (TA-3 (Australia)/3E)	1		OB80228A	AC Power Cord (TA-3E)	1
	OB50128A	Power Transformer (TA-3A)	1	39	OB90274A	AC Power Cord (TA-30)	1
	OB50132A	Power Transformer (TA-30)	1	40	OJ05742A	P.C.B. Spacer	1
02	BA07424A	Power Supply P.C.B. Ass'y (TA-3 (Other))	1	41	OJ05736A	Remote P.C.B. Holder	1
	BA07426A	Power Supply P.C.B. Ass'y (TA-3 (Australia)/3E)	1	42	BA07442A	Video P.C.B. Ass'y (TA-3/3A/30)	1
	BA07422A	Power Supply P.C.B. Ass'y (TA-3A)	1	43	BA07459A	Video P.C.B. Ass'y (TA-3E)	1
	BA07423A	Power Supply P.C.B. Ass'y (TA-30)	1	44	OJ05710A	Shorting Pin	2
03	OJ05732A	Side Chassis R	1	45	JA04383A	Ground Terminal Ass'y	1
04	OJ05738A	Spacer Support A	2	46	OB90316A	AM Antenna Holder	1
05	OJ05739A	Spacer Support B	1	47	OB08515A	Insu-Lock 100	20
06	OB80211A	Glass Tube 150	1	48	BA07441A	Subsonic P.C.B. Ass'y	1
07	OB80212A	Glass Tube 100	1	49	BA07505A	IF Band Switch P.C.B. Ass'y (TA-3 (Other))	1
08	—	Heat Sink Ass'y	1	50	OB70049A	Voltage Selector Switch (TA-3 (Other))	1
09	OJ05729A	P.C.B. Holder B	1	L01	BA07500A	Phono Input P.C.B. Ass'y (TA-3E)	1
10	BA07563A	Logic P.C.B. Ass'y (TA-3 (Other))	1		OB90399A	Lithium Battery [B501]	1
	BA07455A	Logic P.C.B. Ass'y (TA-3 (Australia)/3E)	1		OE03426A	ST4x8 @ Pan Projected (Black Chromate) (TA-3/3E/30)	4
	BA07437A	Logic P.C.B. Ass'y (TA-3A)	1	L02	OE00929A	M4x8 @ Binding (TA-3A)	4
	BA07547A	Logic P.C.B. Ass'y (TA-30)	1	L03	OE00031A	Washer 4x8x0.5 (TA-3A)	4
11	OJ05735A	Logic P.C.B. Holder	1	L04	OE00868A	BT 3x8 @ Binding (Black Chromate)	32
12	OJ05728A	P.C.B. Holder A	1	L05	OE03433A	BT 3x6 @ Binding Projected (Black Chromate)	2
13	OJ05670A	Earth Plate	2	L06	OE00921A	BT 3x8 @ Binding (Black Chromate)	20
14	BA07419A	Main P.C.B. Ass'y (TA-3 (Other))	1	L07	OE00766A	M3x8 @ Binding	3
	BA07420A	Main P.C.B. Ass'y (TA-3 (Australia))	1	L08	OE03382A	Nut Hex. M7	4
	BA07417A	Main P.C.B. Ass'y (TA-3A)	1	L09	OE03383A	Washer M7	4
	BA07421A	Main P.C.B. Ass'y (TA-3E)	1	L10	OE03375A	Nut Hex. M9	2
	BA07418A	Main P.C.B. Ass'y (TA-30)	1	L11	OE03376A	Washer M9	2
15	OH05325A	Power Button	1	L12	OJ05673A	Nut 70 ZN3A	1
16	—	Front Chassis Ass'y	1	L13	OE00071A	Washer 3mm Fiber	1
17	BA07504A	Power LED P.C.B. Ass'y	1	L14	OJ05427A	Mounting Plate	1
18	BA07613A	Power Switch P.C.B. Ass'y (TA-3 (Other))	1	L15	OE03278A	BT 3x8 @ Tapping (Black Chromate)	2
	BA07416A	Power Switch P.C.B. Ass'y (TA-3 (Australia)/3E)	1	L16	OE03202A	M2.6x3 @ Binding (Black Chromate) (TA-3 (Other))	4
	BA07414A	Power Switch P.C.B. Ass'y (TA-3A)	1	L17	OE00985A	M3x6 @ Binding (Black Chromate) (TA-3 (Other))	2
	BA07415A	Power Switch P.C.B. Ass'y (TA-30)	1	L18	OE03070A	M2.6x6 @ Binding	1
19	BA07503A	Headphone P.C.B. Ass'y	1		OB09290A	Ceramic Capacitor 0.01μ 50V Z (TA-3E)	2
20	OJ05612A	Volume Ground Plate A	1		OB09292A	Ceramic Capacitor 0.1μ 50V Z (TA-3E)	1
21	BA07439A	Record Selector P.C.B. Ass'y	1		OM05270A	Lithium Caution Label (TA-3E)	1
22	BA07438A	Tone Control P.C.B. Ass'y (TA-3/3A/30)	1		OB90019A	Insu-Lock	2
	BA07609A	Tone Control P.C.B. Ass'y (TA-3E)	1		OB90400A	Fiber Washer 6mm	2
23	BA07427A	Control Switch & Display P.C.B. Ass'y (TA-3/3A)	1		OJ05214A	P.C.B. Cushion	2
	BA07428A	Control Switch & Display P.C.B. Ass'y (TA-3E)	1		OE00174A	Earth Lug (TA-3E)	4
	BA07548A	Control Switch & Display P.C.B. Ass'y (TA-30)	1				
24	OJ05703A	Lug Terminal 7	2				
25	BA07502A	Loudness P.C.B. Ass'y	1				
26	OJ05737A	Front Stud	2				
27	OJ05730A	Front Chassis	1				
28	OJ05731A	Chassis L	1				
29	OJ05733A	Volume Holder	1				
30	BA07501A	Motor Volume P.C.B. Ass'y	1				
31	OJ05726A	Front Holder	1				
32	BA07615A	Speaker Terminal P.C.B. Ass'y (TA-3/30)	1				
	BA07457A	Speaker Terminal P.C.B. Ass'y (TA-3A)	1				
	BA07458A	Speaker Terminal P.C.B. Ass'y (TA-3E)	1				
33	OJ05753A	Damping Sheet	2				
34	BA07544A	AC Outlet P.C.B. Ass'y (TA-3 (Other)/30)	1				
	BA07456A	AC Outlet P.C.B. Ass'y (TA-3A)	1				
35	OB81928A	AC Outlet AC-T05LB57 (TA-3 (Other)/3A)	1				
	OB81986A	AC Outlet (TA-3 (Australia))	1				
	OB81987A	AC Outlet (TA-3E)	1				
	OB81986A	AC Outlet 2P (TA-30)	1				
36	OH05413A	Rear Panel (TA-3 (Other))	1				
	OH05414A	Rear Panel (TA-3 (Australia))	1				
	OH05411A	Rear Panel (TA-3A)	1				
	OH05415A	Rear Panel (TA-3E)	1				
	OH05412A	Rear Panel (TA-30)	1				

5.3. Heat Sink Ass'y (B01)

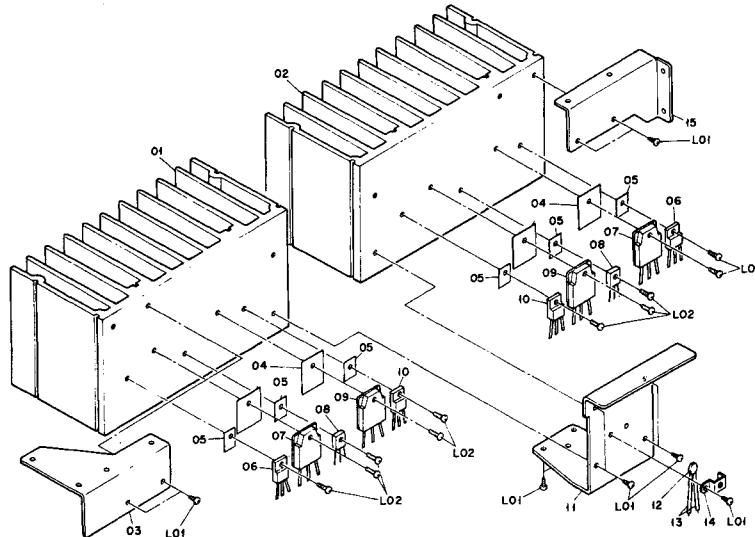

Fig. 5.3

5.4. Front Chassis Ass'y (B02)

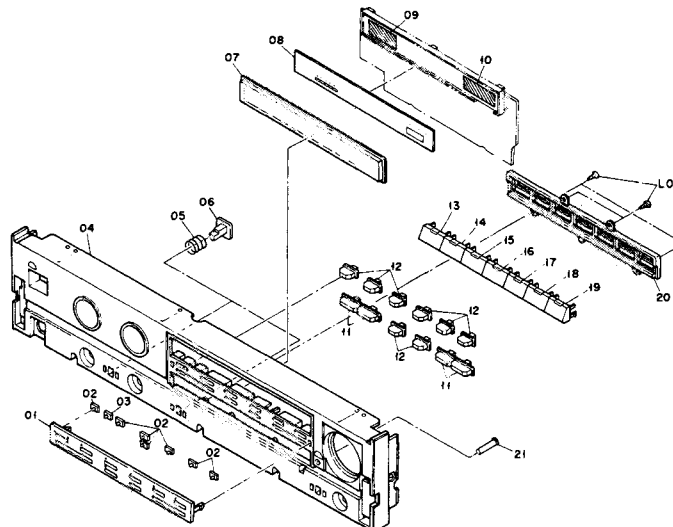

Fig. 5.4

Schematic Ref. No.	Part No.	Description	Q'ty	Schematic Ref. No.	Part No.	Description	Q'ty
5.3. Heat Sink Ass'y (B01)				5.4. Front Chassis Ass'y (B02)			
B01	—	Heat Sink Ass'y	1	B02	—	Front Chassis Ass'y	1
01	OJ05723A	Heat Sink A	1	01	OH05432A	Memory Plate	1
02	OJ05724A	Heat Sink B	1	02	OH05426A	Preset Lens A	7
03	OJ05718A	Heat Sink Holder F	1	03	OH05427A	Preset Lens B	1
04	OJ05671A	Insulator SIL 3P	4	04	OH05431A	Front Chassis	1
05	OJ05672A	Insulator SIL 220	6	05	OJ05406A	Push Spring	2
06	OB10293A	Transistor 2SA957 [Q311L,R]	2	06	OH05322A	Push Button	2
07	OB10295A	Transistor 2SC3856 (O,Y) [Q313L,R]	2	07	OH05326A	Display Lens	1
08	OB10287A	Transistor 2SB772 (P,Q) [Q309L,R]	2	08	OH05430A	Display Overlay 1089	1
09	OB10294A	Transistor 2SA1492 (O,Y) [Q312L,R]	2	09	OJ05708A	Diffuser Sheet A	1
10	OB10292A	Transistor 2SC2167 [Q310L,R]	2	10	OJ05709A	Diffuser Sheet B	1
11	OJ05725A	Joint Holder	1	11	OH05324A	Up/Down Button	4
12	OB19012A	Thermistor 50KD-5 [TH301]	1	12	OH05323A	Preset Button	8
13	OB80209A	Glass Tube 16	2	13	HA05546A	Phono Button Ass'y	1
14	OJ05615A	TH Holder	1	14	HA05547A	CD Button Ass'y	1
15	OJ05719A	Heat Sink Holder R	1	15	HA05548A	Tuner Button Ass'y	1
L01	OE00868A	BT3x8 @ Binding	13	16	HA05549A	Video 1 Button Ass'y	1
L02	OE00986A	M3x10 @ Binding	10	17	HA05550A	Video 2 Button Ass'y	1
—	OB90368A	Transistor Bush 3x1.4	4	18	HA05551A	Tape 1 Button Ass'y	1
				19	HA05552A	Tape 2 Button Ass'y	1
				20	OJ05712A	Button Base	1
				21	OH05438A	Mute Knob	1
				L01	OE00868A	BT3x8 @ Binding	4

6. MOUNTING DIAGRAMS AND PARTS LIST

- Notes: 1. Mounting diagram shows a dip side view of the printed circuit board.
 2. Diode is 1SS53, 1S1555, 1SS176 or 1N4148 unless otherwise specified.
 3. Following transistors are interchangeable with each other.
 a. 2SA733, 2SA608SP, 2SA1048, 2SA1175
 b. 2SC945, 2SC536SP, 2SC2458, 2SC2785
 4. Abbreviation for part name:
 TR — Transistor, SiD — Silicon Diode, ZD — Zener Diode, Varicap — Variable Capacitance Diode
 RK — Carbon Resistor, RM — Metal Film Resistor, RF — Fail Safe Type Resistor
 CE — Electrolytic Capacitor, CML — Mylar Capacitor, CC — Ceramic Capacitor, CPP — PP Capacitor,
 CMM — Metalized Mylar Capacitor, CSP — Polystyrene Capacitor, C — Mica Capacitor

6.1. AC Outlet P.C.B. Ass'y

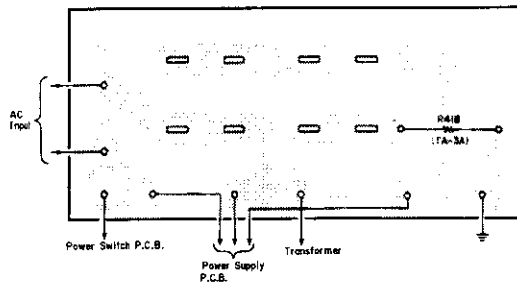

Fig. 6.1

6.2. Power Switch P.C.B. Ass'y

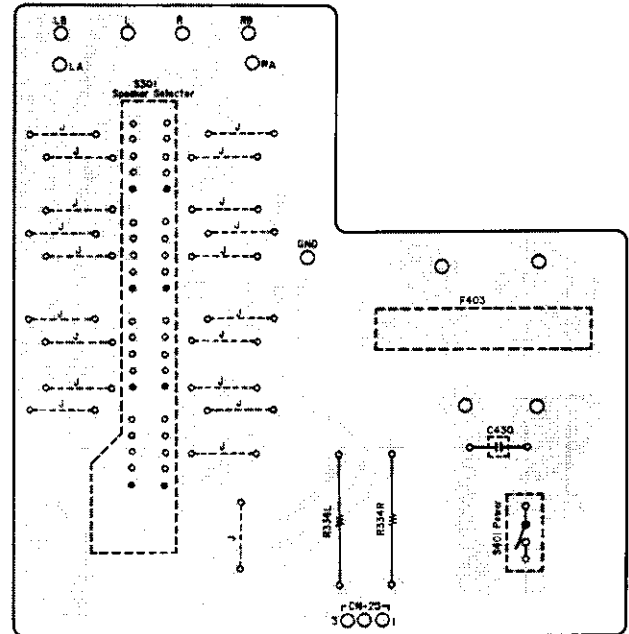

Fig. 6.2

6.3. Speaker Terminal P.C.B. Ass'y

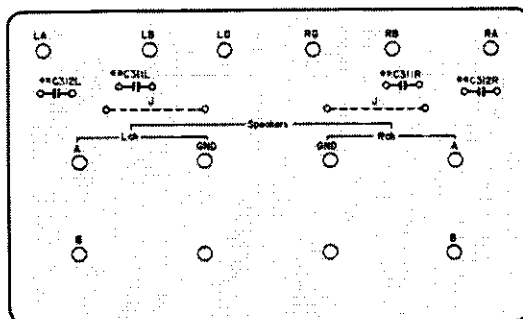

Fig. 6.3

Schematic Ref. No.	Part No.	Description	Schematic Ref. No.	Part No.	Description	Schematic Ref. No.	Part No.	Description
6.1. AC Outlet P.C.B. Ass'y			S301	OB70142A	Rotary Switch	6.3. Speaker Terminal P.C.B. Ass'y		
R418	BA07456A	AC Outlet P.C.B. Ass'y (TA-3A)	OB71010A	Power Switch (TA-3/3A/3E)	C311L,R C312L,R	BA07615A	Speaker Terminal P.C.B. Ass'y (TA-3/30)	
	BA07544A	AC Outlet P.C.B. Ass'y (TA-3 (Other)/30)	S401	OB71011A		Power Switch (TA-30)	BA07457A	Speaker Terminal P.C.B. Ass'y (TA-3A)
	OB60622A	AC Outlet P.C.B. RK 3.3M 1/2W J (TA-3A)	F403	OB90350A		Fuse T2.5A 250V (TA-3 (Australia)/3E)	BA07458A	Speaker Terminal P.C.B. Ass'y (TA-3E)
	OB05919A	Insu-Lock 100 (TA-3 (Other)/30)	F403	OB90348A		Fuse T5A 250V (TA-3 (Other)/3A)	OB60647A	Speaker Terminal P.C.B.
	OB08515A	Insu-Lock 100 (TA-3 (Other)/30)	F403	OB90352A		Fuse 5A 250V (TA-30)	OB05582A	CML 0.022μ 50V J (TA-3E)
6.2. Power Switch P.C.B. Ass'y			OB81848A	Fuse Holder (TA-3 (Australia)/3E)		OB05582A	CML 0.022μ 50V J (TA-3E)	
R334L,R C430	BA07413A	Power Switch P.C.B. Ass'y (TA-3 (Other))	OB81930A	Fuse Holder SN-5051 (TA-3 (Other)/3A/30)	(2)	OB81950A	Speaker Terminal 8P (1)	
	BA07416A	Power Switch P.C.B. Ass'y (TA-3 (Australia)/3E)						
	BA07414A	Power Switch P.C.B. Ass'y (TA-3A)						
	BA07415A	Power Switch P.C.B. Ass'y (TA-30)						
	OB60640A	Power Switch P.C.B. RF 330 2W						
	OB24208A	CC 4700P AC400V						
	OB41829A							

6.4. Headphone P.C.B. Ass'y

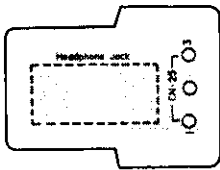

Fig. 6.4

6.5. Power LED P.C.B. Ass'y

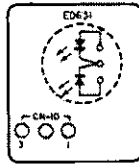

Fig. 6.5

6.6. Volume LED P.C.B. Ass'y

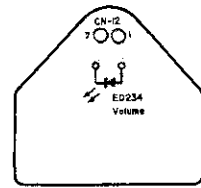

Fig. 6.6

6.7. Subsonic P.C.B. Ass'y

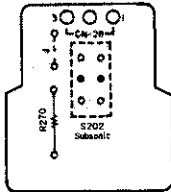

Fig. 6.7

6.8. Phono Input P.C.B. Ass'y

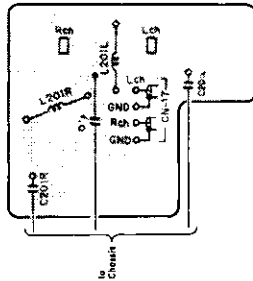

Fig. 6.8

6.9. Record Selector P.C.B. Ass'y

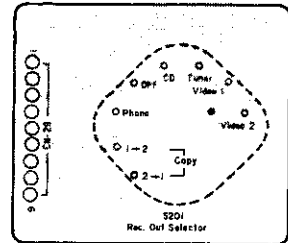

Fig. 6.9

6.10. Loudness P.C.B. Ass'y

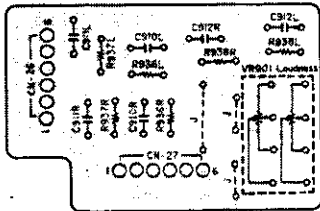

Fig. 6.10

Schematic Ref. No.	Part No.	Description	Schematic Ref. No.	Part No.	Description	Schematic Ref. No.	Part No.	Description	
6.4. Headphone P.C.B. Ass'y			6.7. Subsonic P.C.B. Ass'y			6.10. Loudness P.C.B. Ass'y			
CN25	BA07503A	Headphone P.C.B. Ass'y	R270 S202	BA07441A	Subsonic P.C.B. Ass'y	VR901 R936L,R R937L,R R938L,R C910L,R C911L,R C912L,R CN26 CN27	BA07502A	Loudness P.C.B. Ass'y	
	OB60643A OB83511A OB81757A	Headphone P.C.B. Ribbon Wire 3P 140 Headphone Jack (1)		OB60636A OB05620A OB70127A	Subsonic P.C.B. RK 270K 1/4W J Push Switch PSR-221 3P Connector Ass'y 300		OB60642A OB30097A OB09709A OB09699A OB09707A OB05550A OB05582A OB01780A OB83515A OB83502A	Loudness P.C.B. VR 300Kx2 RK 22K 1/6W J RK 8.2K 1/6W J RK 18K 1/6W J CML 1000P 50V J CML 0.022μ 50V J CML 0.1μ 50V J Ribbon Wire 6P 140 6P Connector Ass'y 300	
6.5. Power LED P.C.B. Ass'y			6.8. Phono Input P.C.B. Ass'y						
ED631 CN10	BA07504A	Power LED P.C.B. Ass'y	L201L,R C201L,R	BA07500A	Phono Input P.C.B. Ass'y (TA-3E)				
	OB60644A OB12421A OB83512A	Power LED P.C.B. LED P-Green/Red SPR-56PDWF M Ribbon Wire 3P 360		OB60658A OB51266A OB41071A OB09292A	Phono Input P.C.B. Coil 48μH CC 100P 50V J CC 0.1μ 50V Z				
6.6. Volume LED P.C.B. Ass'y			6.9. Record Selector P.C.B. Ass'y						
ED234 CN12	BA07440A	Volume LED P.C.B. Ass'y	S201 CN29	BA07439A	Record Selector P.C.B. Ass'y				
	OB60635A OB12395A OB83685A	Volume LED P.C.B. LED P-Green SLR-34PC3F 2P Connector Ass'y 230		OB60621A OB70143A OB83678A	Record Selector P.C.B. Rotary Switch MSB18BP 9P Connector Ass'y 500				

6.11. Motor Volume P.C.B. Ass'y

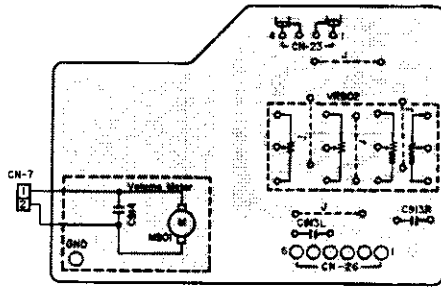

Fig. 6.11

6.12. IF Band Switch P.C.B. Ass'y

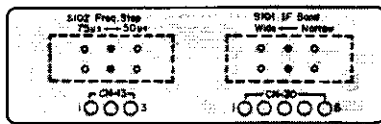

Fig. 6.12

6.13. Tone Control P.C.B. Ass'y

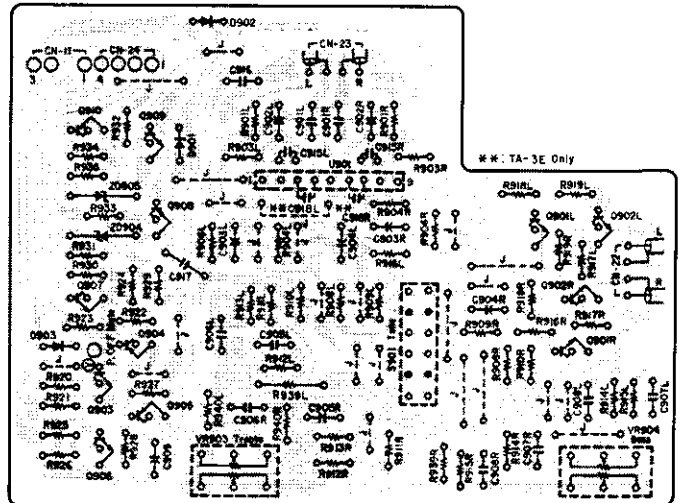

Fig. 6.13

Schematic Ref. No.	Part No.	Description	Schematic Ref. No.	Part No.	Description	Schematic Ref. No.	Part No.	Description
6.11. Motor Volume P.C.B. Ass'y			6.13. Tone Control P.C.B. Ass'y			R939L	OB05576A	RK 470 1/4W J
	BA07501A	Motor Volume P.C.B. Ass'y		BA07438A	Tone Control P.C.B. Ass'y (TA-3/3A/30)	R939R	OB09669A	RK 470 1/6W J
	OB60641A	Motor Volume P.C.B.		BA07609A	Tone Control P.C.B. Ass'y (TA-3E)	R940L,R	OB09705A	RK 15K 1/6W J
VR902	OB30096A	VR 50KBx2		OB60620A	Tone Control P.C.B. IC	C901L,R	OB41394A	CCP 220P 50V J
C913L,R	OB41739A	CC 22P 50V J	U901	OB60613A	TR 2SC2878	C902L,R	OB09332A	CE 2.2μ 50V (LN)
C914	OB09292A	CC 0.1μ 50V Z	Q901L,R	OB6299A	TR 2SC2878	C903L,R	OB09333A	CE 4.7μ 50V
CN7	OB83490A	2P Connector Ass'y 200	Q902L,R	OB6100A	TR 2SC945 (K,P,Q)	C904L,R	OB09218A	CE 47μ 16V (LN)
	OB08515A	Insu-Lock 100 (1)	Q903	OB6100A	TR 2SA733 (P,Q)	C905L,R	OB05682A	CML 0.068μ 50V J
	OJ05703A	Lug Terminal 7 (1)	Q904,905	OB6100A	TR 2SC945 (K,P,Q)	C906L,R	OB41378A	CML 0.33μ 50V J
			Q906,907	OB60613A	TR 2SA733 (P,Q)	C907L,R	OB09189A	CML 2700P 50V J
			Q908	OB6100A	TR 2SC945 (K,P,Q)	C908L,R	OB05832A	CML 0.18μ 50V J
			Q909	OB60613A	TR 2SA733 (P,Q)	C909	OB01502A	CE 330μ 16V
			Q910	OB12614A	ZD 12V B2	C915L,R	OB41739A	CC 22P 50V J
			ZD904,905	OB06398A	SID 1S5176	C916,917	OB09292A	CC 0.1μ 50V Z
			D901	OB12584A	SID 1N4148	C918L,R	OB41735A	CC 100P 50V J
			D902	OB06398A	SID 1S5176			(TA-3E)
			D903	OB30095A	VR 50KCx2	S901	OB70140A	Push Switch
			VR903	OB30090A	VR 100KCx2	CN11	OB83494A	3P Connector Ass'y 350
			VR904	OB09653A	RK 100 1/6W J	CN22	OB83498A	4P Connector Ass'y 500
			R901L,R	OB09729A	RK 150K 1/6W J	CN23A	OB83548A	Lead Wire 400
			R903L,R	OB09748A	RK 560K 1/6W J	CN23B	OB83549A	Lead Wire 400
			R904L,R	OB22457A	RM 100K 1/4W F	CN24	OB83496A	4P Connector Ass'y 400
			R906L,R	OB22351A	RM 12.0K 1/4W F	Y-Y	OB83506A	Ter. Grip Ass'y (1)
			R906L,R	OB22351A	RM 12.0K 1/4W F			
			R908L,R	OB22229A	RM 1.00K 1/4W F			
			R909L,R	OB09703A	RK 12K 1/6W J			
			R910L,R	OB09723A	RK 82K 1/6W J			
			R911L,R	OB09684A	RK 2K 1/6W J			
			R912L,R	OB09687A	RK 2.7K 1/6W J			
			R913L,R	OB09673A	RK 680 1/6W J			
			R914L,R	OB09677A	RK 1K 1/6W J			
			R915L,R	OB09653A	RK 100 1/6W J			
			R916L,R	OB09701A	RK 10K 1/6W J			
			R917L,R	OB09701A	RK 10K 1/6W J			
			R918	OB09701A	RK 10K 1/6W J			
			R919L,R	OB09725A	RK 100K 1/6W J			
			R920	OB09717A	RK 47K 1/6W J			
			R921	OB09725A	RK 100K 1/6W J			
			R922,923	OB09701A	RK 10K 1/6W J			
			R924	OB09701A	RK 10K 1/6W J			
			R925,926	OB09725A	RK 100K 1/6W J			
			R927,928	OB09677A	RK 1K 1/6W J			
			R929	OB09673A	RK 680 1/6W J			
			R930	OB09677A	RK 1K 1/6W J			
			R931	OB09677A	RK 1K 1/6W J			
			R932,933	OB09677A	RK 1K 1/6W J			
			R934	OB09677A	RK 1K 1/6W J			
			R935	OB09673A	RK 680 1/6W J			

6.14. Power Supply P.C.B. Ass'y

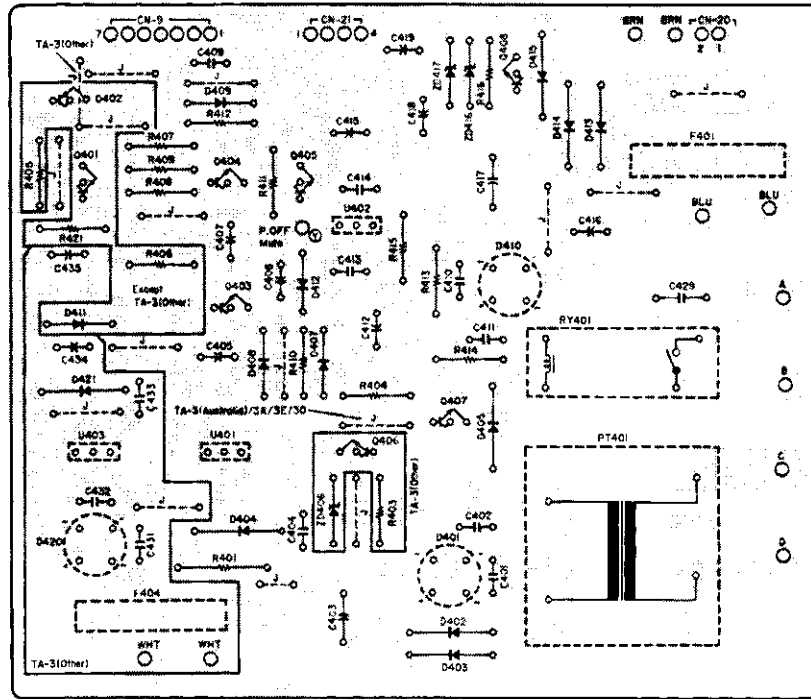

Fig 6.14

Schematic Ref. No.	Part No.	Description	Schematic Ref. No.	Part No.	Description	Schematic Ref. No.	Part No.	Description
6.14. Power Supply P.C.B. Ass'y			D420	OB12604A	SID WO2M (TA-3 (Other))	C412	OB40095A	CE 1000μ 25V
	BA07424A	Power Supply P.C.B. Ass'y (TA-3 (Other))	D421	OB12586A	SID 1N4002 (TA-3 (Other))	C413,414	OB09292A	CC 0.1μ 50V Z
	BA07426A	Power Supply P.C.B. Ass'y (TA-3 (Australia)/3E)	PT401	OB50137A	Sub Transformer (TA-3 (Other)/3A)	C415	OB40079A	CE 220μ 16V
	BA07422A	Power Supply P.C.B. Ass'y (TA-3A)		OB50138A	Sub Transformer (TA-30)	C416	OB40094A	CE 470μ 25V
	BA07423A	Power Supply P.C.B. Ass'y (TA-30)		OB50141A	Sub Transformer (TA-3 (Australia)/3E)	C417	OB40123A	CE 470μ 50V
	OB80619A	Power Supply P.C.B. Ass'y (TA-3 (Other))	R401	OB24210A	RF 56 1W	C418	OB40100A	CE 10μ 35V
U401	OB11010A	IC μPC7805H	R403	OB20519A	RK 820 1/2W J (TA-3 (Other))	C419	OB09126A	CE 100μ 35V
U402	OB11011A	IC μPC7812H	R404	OB05622A	RK 2.2K 1/4W J (Except TA-3 (Other))	C429	OB41829A	CC 4700P AC400V
U403	OB11010A	IC μPC7805H (TA-3 (Other))	R405	OB05576A	RK 470 1/4W J (Other)	C431,432	OB09292A	CC 0.1μ 50V Z (TA-3 (Other))
Q401	OB06100A	TR 2SC945 (K,P,Q) (Except TA-3 (Other))	R406	OB05615A	RK 22K 1/4W J (Except TA-3 (Other))	C433	OB09292A	CC 0.1μ 50V Z (TA-3 (Other))
Q402	OB10097A	TR 2SA952 (K,L) (Except TA-3 (Other))	R407	OB09263A	RK 12K 1/4W J	C434	OB40082A	CE 1000μ 16V (TA-3 (Other))
Q403,404	OB06100A	TR 2SC945 (K,P,Q)	R408	OB01889A	RK 100K 1/4W J	C435	OB05899A	CE 220μ 10V (TA-3 (Other))
Q405	OB06100A	TR 2SC945 (K,P,Q)	R409	OB05615A	RK 22K 1/4W J	RY401	OB90334A	Relay VS 12V
Q406	OB10248A	TR 2SD313 (E) (TA-3 (Other))	R410	OB01682A	RK 6.8K 1/4W J	F401	OB90288A	Fuse T500mA 250V (TA-3 (Australia)/3E)
Q407,408	OB06100A	TR 2SC945 (K,P,Q)	R411,412	OB01889A	RK 100K 1/4W J		OB90345A	Fuse T0.5A 250V (TA-3 (Other)/3A)
ZD406	OB12390A	ZD 13VRD13EB3 (TA-3 (Other))	R413,414	OB01681A	RK 3.3K 1/4W J	F404	OB90289A	Fuse T1A 250V (TA-3 (Other))
ZD416,417	OB12615A	ZD 15V B2	R415	OB05622A	RK 2.2K 1/4W J	CN9	B83505A	7P Connector Ass'y 400
D401	OB12604A	SID WO2M	R416	OB05575A	RK 560 1/4W J	CN20	OB83686A	2P Connector Ass'y 300
D402,403	OB12586A	SID 1N4002	R421	OB01888A	RK 10K 1/4W J (Except TA-3 (Other))	CN21	OB83497A	4P Connector Ass'y 450
D404,405	OB12586A	SID 1N4002	C401,402	OB09292A	CC 0.1μ 50V Z		OB81848A	Fuse Holder (2)
D407,408	OB12584A	SID 1N4148	C403	OB40339A	CE 470μ 35V (TA-3 (Other))			
D409	OB12584A	SID 1N4148		OB40082A	CE 1000μ 16V (Except TA-3 (Other))			
D410	OB12604A	SID WO2M	C404	OB09292A	CC 0.1μ 50V Z			
D411	OB12584A	SID 1N4148 (Except TA-3 (Other))	C405	OB40068A	CE 1000μ 10V			
D412	OB12584A	SID 1N4148	C407,408	OB09372A	CE 2.2μ 50V			
D413,414	OB12586A	SID 1N4002	C409,410	OB09292A	CC 0.1μ 50V Z			
D415	OB12586A	SID 1N4002	C411	OB09292A	CC 0.1μ 50V Z			

6.16. Video P.C.B. Ass'y

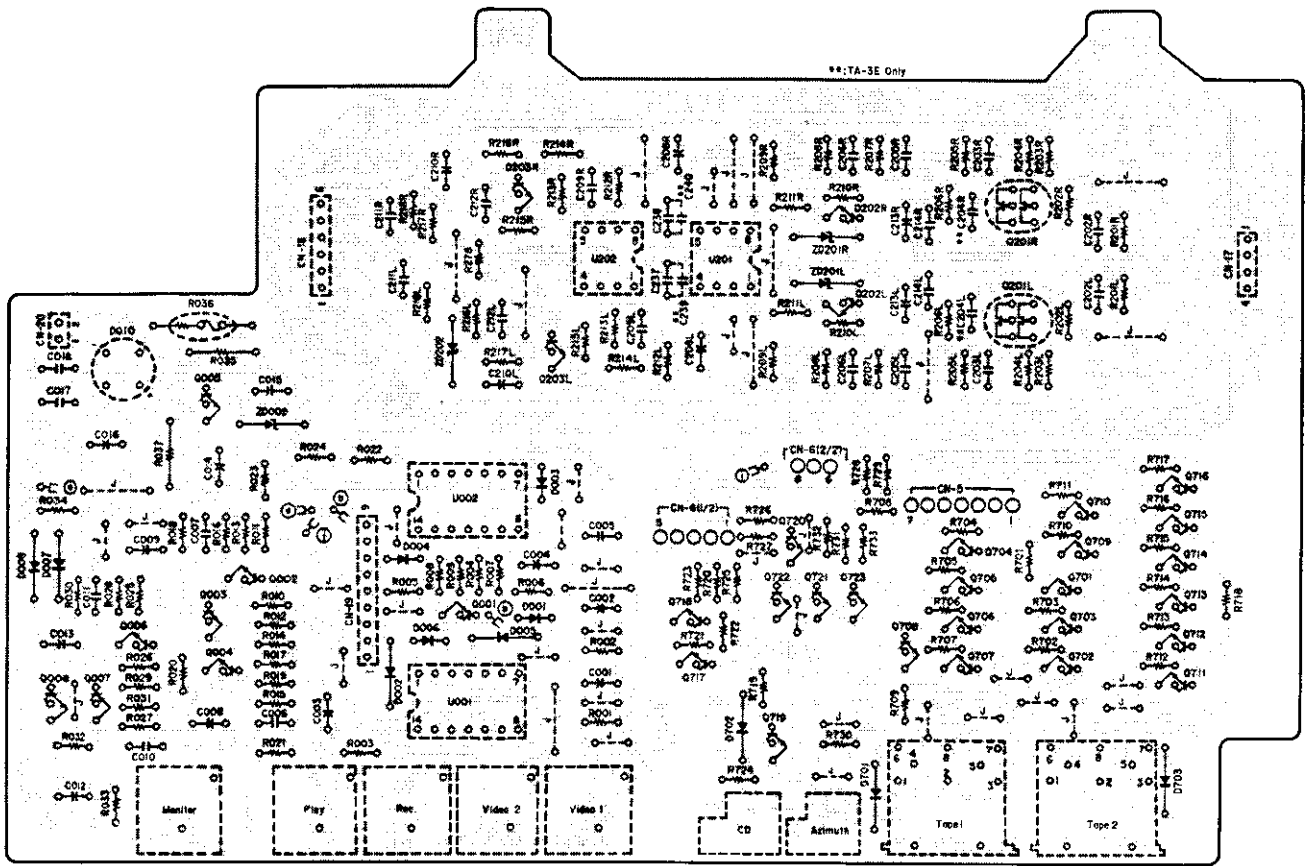

Fig. 6.16

Schematic Ref. No.	Part No.	Description	Schematic Ref. No.	Part No.	Description
6.16. Video P.C.B. Ass'y			R212L,R	OB09687A	RK 2.7K 1/6W J
	BA07442A	Video P.C.B. Ass'y (TA-3/3A/30)	R213L,R	OB09741A	RK 470K 1/6W J
	BA07459A	Video P.C.B. Ass'y (TA-3E)	R214L,R	OB09693A	RK 4.7K 1/6W J
	OB60646A	Video P.C.B.	R215L,R	OB09749A	RK 1M 1/6W J
U001,002	OB06169A	IC TC4066BP	R216L,R	OB09741A	RK 470K 1/6W J
U201	OB06146A	IC NJM4558DD	R217L,R	OB09725A	RK 100K 1/6W J
U202	OB11005A	IC 072DE	R218L,R	OB09657A	RK 150 1/6W J
Q001	OB06013A	TR 2SA733 (P,Q)	R278	OB09741A	RK 470K 1/6W J
Q002	OB06100A	TR 2SC945 (K,P,Q)	R701,702	OB09701A	RK 10K 1/6W J
Q003	OB06013A	TR 2SA733 (P,Q)	R703,704	OB09701A	RK 10K 1/6W J
Q004	OB06100A	TR 2SC945 (K,P,Q)	R705,706	OB09701A	RK 10K 1/6W J
Q005	OB06452A	TR 2SD1406	R707,708	OB09701A	RK 10K 1/6W J
Q006	OB06100A	TR 2SC945 (K,P,Q)	R709	OB09677A	RK 1K 1/6W J
Q007	OB06013A	TR 2SA733 (P,Q)	R710,711	OB09701A	RK 10K 1/6W J
Q008	OB06100A	TR 2SC945 (K,P,Q)	R712,713	OB09701A	RK 10K 1/6W J
Q201L,R	OB10188A	FET 2SK240 (BL)	R714,715	OB09701A	RK 10K 1/6W J
Q202L,R	OB06100A	TR 2SC945 (K,P,Q)	R716,717	OB09701A	RK 10K 1/6W J
Q203L,R	OB06299A	TR 2SC2878	R718	OB09677A	RK 1K 1/6W J
Q701,702	OB06100A	TR 2SC945 (K,P,Q)	R719	OB09709A	RK 22K 1/6W J
Q703,704	OB06100A	TR 2SC945 (K,P,Q)	R720,721	OB09701A	RK 10K 1/6W J
Q705,706	OB06100A	TR 2SC945 (K,P,Q)	R722,723	OB09701A	RK 10K 1/6W J
Q707,708	OB06100A	TR 2SC945 (K,P,Q)	R724	OB09637A	RK 22 1/6W J
Q709,710	OB06100A	TR 2SC945 (K,P,Q)	R725,726	OB09701A	RK 10K 1/6W J
Q711,712	OB06100A	TR 2SC945 (K,P,Q)	R727	OB09701A	RK 10K 1/6W J
Q713,714	OB06100A	TR 2SC945 (K,P,Q)	R728,729	OB09637A	RK 22 1/6W J
Q715,716	OB06100A	TR 2SC945 (K,P,Q)	R730	OB09637A	RK 22 1/6W J
Q717,718	OB06100A	TR 2SC945 (K,P,Q)	R731,732	OB09701A	RK 10K 1/6W J
Q719,720	OB06100A	TR 2SC945 (K,P,Q)	R733	OB09701A	RK 10K 1/6W J
Q721,722	OB06100A	TR 2SC945 (K,P,Q)	C001,002	OB01862A	CE 22μ 16V
Q723	OB06100A	TR 2SC945 (K,P,Q)	C003,004	OB01862A	CE 22μ 16V
ZD009	OB12390A	ZD 13V RD13EB3	C005	OB01862A	CE 22μ 16V
ZD201L,R	OB06233A	ZD 10V RD10EB3	C006	OB05905A	CC 5P 50V C
ZD202	OB12627A	ZD 18V B2	C007	OB41738A	CC 390P 50V J
D001	OB06398A	SiD 1SS176	C008	OB40082A	CE 1000μ 16V
D002	OB12584A	SiD 1N4148	C009	OB01400A	CE 100μ 16V
D003,004	OB06398A	SiD 1SS176	C010	OB05905A	CC 5P 50V C
D005	OB12584A	SiD 1N4148	C011	OB41738A	CC 390P 50V J
D006	OB06398A	SiD 1SS176	C012	OB40082A	CE 1000μ 16V
D007,008	OB12584A	SiD 1N4148	C013,014	OB01400A	CE 100μ 16V
D010	OB12604A	SiD WO2M	C015	OB01398A	CE 220μ 16V
D701,702	OB12584A	SiD 1N4148	C016	OB40094A	CE 470μ 25V
D703	OB12584A	SiD 1N4148	C017,018	OB09292A	CC 0.1μ 50V Z
R001,002	OB09650A	RK 75 1/6W J	C202L,R	OB41894A	CSP 100P 100V J (TA-3/3A/30)
R003	OB09650A	RK 75 1/6W J		OB09281A	CC 150P 50V K (TA-3E)
R004,005	OB09749A	RK 1M 1/6W J	C204L,R	OB41735A	CC 100P 50V J (TA-3E)
R006,007	OB09749A	RK 1M 1/6W J	C203L,R	OB41175A	CML 0.15μ 50V J
R008,009	OB09749A	RK 1M 1/6W J	C205L,R	OB41138A	CPP 3600P 100V G
R010	OB09651A	RK 82 1/6W J	C206L,R	OB41125A	CPP 1000P 100V G
R011	OB09691A	RK 3.9K 1/6W J	C208L,R	OB09332A	CE 2.2μ 50V (LN)
R012	OB09679A	RK 1.2K 1/6W J	C209L,R	OB05582A	CML 0.022μ 50V J
R013	OB09677A	RK 1K 1/6W J	C210L,R	OB09148A	CE 10μ 25V (LN)
R014	OB09665A	RK 330 1/6W J	C211L,R	OB41209A	CE 220P 100V J
R015,016	OB09669A	RK 470 1/6W J	C212L,R	OB09292A	CC 0.1μ 50V Z
R017	OB09683A	RK 1.8K 1/6W J	C213L,R	OB09137A	CE 22μ 25V
R018	OB09653A	RK 100 1/6W J	C214L,R	OB05681A	CML 0.01μ 50V J
R019	OB09661A	RK 220 1/6W J	C237,238	OB05796A	CML 0.047μ 50V J
R020	OB09649A	RK 68 1/6W J	C239,240	OB09291A	CC 0.022μ 50V Z (TA-3E)
R021	OB09701A	RK 10K 1/6W J	CN5	OB83681A	7P Connector Ass'y 300
R022	OB09651A	RK 82 1/6W J	CN6	OB83680A	8P Connector Ass'y 300
R023	OB09691A	RK 3.9K 1/6W J	CN17	OB81761A	4P-T Post
R024	OB09679A	RK 1.2K 1/6W J	CN18	OB81763A	6P-T Post
R025	OB09677A	RK 1K 1/6W J	CN19	OB81766A	9P-T Post
R026	OB09665A	RK 330 1/6W J	CN20	OB81759A	2P-T Post
R027,028	OB09669A	RK 470 1/6W J	A-A	OB83463A	Lead Wire 60
R029	OB09683A	RK 1.8K 1/6W J	B-B	OB83463A	Lead Wire 60
R030	OB09653A	RK 100 1/6W J	J-J	OB83676A	Lead Wire 100
R031	OB09661A	RK 220 1/6W J		OB81754A	DIN Socket 8P (2)
R032	OB09649A	RK 68 1/6W J		OB81947A	Pin Jack 1P (5)
R033	OB09701A	RK 10K 1/6W J		OB81952A	ST Mini Jack (2)
R034	OB09725A	RK 100K 1/6W J			
R035	OB05698A	RK 1.5K 1/4W J			
R037	OB01857A	RK 1K 1/4W J			
R036	OB24023A	Fuse Resistor 1			
R201L,R	OB09718A	RK 51K 1/6W J			
R202L,R	OB09623A	RK 5.6 1/6W J			
R203L,R	OB22305A	RM 4.70K 1/4W F			
R204L,R	OB09637A	RK 22 1/6W J			
R205L,R	OB22305A	RM 4.70K 1/4W F			
R206L,R	OB22250A	RM 1.60K 1/4W F			
R207L,R	OB09661A	RM 909K 1/4W F			
R208L,R	OB22443A	RM 75.0K 1/4W F			
R209L,R	OB09669A	RK 470 1/6W J			
R210L,R	OB09695A	RK 5.6K 1/6W J			
R211L,R	OB22256A	RM 1.80K 1/4W F			

Schematic Ref. No.	Part No.	Description	Schematic Ref. No.	Part No.	Description	Schematic Ref. No.	Part No.	Description
6.17. Logic P.C.B. Ass'y			R533	OB09689A	RK 3.3K 1/6W J	C522	OB09291A	CC 0.022μ 50V Z
			R534	OB09683A	RK 1.8K 1/6W J	C523,524	OB01674A	CE 10μ 25V
	BA07563A	Logic P.C.B. Ass'y (TA-3 (Other))	R535	OB09689A	RK 3.3K 1/6W J	C525	OB01409A	CE 47μ 25V
	BA07455A	Logic P.C.B. Ass'y (TA-3 (Australia)/3E)	R536,537	OB09701A	RK 10K 1/6W J	C526	OB40117A	CE 22μ 50V
			R538,539	OB09701A	RK 10K 1/6W J	C527,528	OB09291A	CC 0.022μ 50V Z
			R540,541	OB09701A	RK 10K 1/6W J (TA-3 (Other)/3E)	C529	OB01405A	CE 1μ 50V
	BA07437A	Logic P.C.B. Ass'y (TA-3A)	R542	OB09693A	RK 4.7K 1/6W J (TA-3 (Other)/3E)	C530	OB41737A	CC 330P 50V J
	BA07547A	Logic P.C.B. Ass'y (TA-30)	R543,544	OB09701A	RK 10K 1/6W J (TA-3 (Other)/3E)	C531	OB09291A	CC 0.022μ 50V Z
			R545,546	OB09701A	RK 10K 1/6W J (TA-3 (Other)/3E)	C532	OB40029A	CE 4.7μ 50V
	OB60638A	Logic P.C.B.				C533,534	OB09286A	CC 470P 50V K
U501	OB11159A	IC TD6104P	R547	OB09709A	RK 22K 1/6W J (TA-3 (Other)/3E)	C535,536	OB09291A	CC 0.022μ 50V Z
U502	OB11161A	IC TC9147BP				C537	OB09291A	CC 0.022μ 50V Z
U503	OB11502A	IC μPD75104CW	R548,549	OB09717A	RK 47K 1/6W J	CN1	OB81759A	2P-T Post
U504	OB11160A	IC TD6301AP	R550	OB09717A	RK 47K 1/6W J	CN2,3	OB81762A	5P-T Post
U505	OB11244A	IC LB1413N	R551,552	OB09661A	RK 220 1/6W J	CN4	OB81761A	4P-T Post
U506	OB11530A	IC BA6208	R553,554	OB09661A	RK 220 1/6W J	CN5	OB81764A	7P-T Post
U507	OB11513A	IC μPD74HC237	R555,556	OB09661A	RK 220 1/6W J	CN6	OB81765A	8P-T Post
Q501,502	OB10265A	TR 2SC1842 (E)	R557,558	OB09661A	RK 220 1/6W J	CN7	OB81759A	2P-T Post
Q503	OB06013A	TR 2SA733 (P,Q)	R559,560	OB09661A	RK 220 1/6W J	CN8	OB81766A	9P-T Post
Q504,505	OB06100A	TR 2SC945 (K,P,Q)	R561,562	OB09661A	RK 220 1/6W J	CN9	OB81764A	7P-T Post
Q506,507	OB06100A	TR 2SC945 (K,P,Q)	R563,564	OB09661A	RK 220 1/6W J	CN11	OB81760A	3P-T Post
Q508	OB06013A	TR 2SA733 (P,Q)	R565,566	OB09661A	RK 220 1/6W J	CN12	OB81759A	2P-T Post
Q509,510	OB06100A	TR 2SC945 (K,P,Q) (TA-3 (Other)/3E)	R567,568	OB09661A	RK 220 1/6W J	CN13	OB81760A	3P-T Post
Q511,512	OB06100A	TR 2SC945 (K,P,Q) (TA-3 (Other)/3E)	R569,570	OB09661A	RK 220 1/6W J			(TA-3 (Other))
Q513,514	OB06100A	TR 2SC945 (K,P,Q)	R571	OB09661A	RK 220 1/6W J	CN14	OB81762A	5P-T Post
Q515,516	OB06100A	TR 2SC945 (K,P,Q)	R572	OB09653A	RK 100 1/6W J	E-E	OB83530A	Lead Wire 160
Q517,518	OB06100A	TR 2SC945 (K,P,Q)	R573	OB09307A	RK 4.3K 1/4W J	F-F	OB83531A	Lead Wire 140
Q519,520	OB06100A	TR 2SC945 (K,P,Q)	R574	OB09661A	RK 220 1/6W J (TA-3 (Other)/3E)	G-G	OB83529A	Lead Wire 60
Q521,522	OB06100A	TR 2SC945 (K,P,Q)	R575,576	OB09654A	RK 110 1/6W J (TA-3 (Other)/3E)	H-H	OB83508A	Ribbon Wire 2P
Q523,524	OB06100A	TR 2SC945 (K,P,Q)	R577	OB09654A	RK 110 1/6W J (TA-3 (Other)/3E)	L-L	OB83688A	Ribbon Wire 4P
Q525	OB06013A	TR 2SA733 (P,Q)				M-M	OB83534A	Lead Wire 80
Q526	OB10263A	TR 2SC2060	R578	OB09665A	RK 330 1/6W J	N-N	OB83534A	Lead Wire 80
Q527,528	OB06100A	TR 2SC945 (K,P,Q)	R579	OB05576A	RK 470 1/4W J		0J05751A	IC Shield Plate A (1)
Q529	OB06100A	TR 2SC945 (K,P,Q)	R580	OB09657A	RK 150 1/6W J		0J05752A	IC Shield Plate B (1)
Q530,531	OB06013A	TR 2SA733 (P,Q)	R581	OB09669A	RK 470 1/6W J			
Q532,533	OB06013A	TR 2SA733 (P,Q)	R582	OB09677A	RK 1K 1/6W J			
Q534,535	OB06013A	TR 2SA733 (P,Q)	R583	OB09701A	RK 10K 1/6W J			
Q536	OB06013A	TR 2SA733 (P,Q)	R584	OB09717A	RK 47K 1/6W J			
ZD520	OB12156A	ZD 6.8V B2	R585	OB09661A	RK 220 1/6W J			
D501	OB12584A	SID 1N4148	R586,587	OB01888A	RK 10K 1/4W J			
D502	OB06398A	SID 1SS176	R588,589	OB01888A	RK 10K 1/4W J			
D503,504	OB12584A	SID 1N4148	R590,591	OB01888A	RK 10K 1/4W J			
D505,506	OB06398A	SID 1SS176	R592	OB01888A	RK 10K 1/4W J			
D507	OB12584A	SID 1N4148	R593,594	OB09701A	RK 10K 1/6W J			
D508	OB06398A	SID 1SS176 (TA-3 (Other)/3E)	R595	OB09701A	RK 10K 1/6W J			
D509,510	OB06398A	SID 1SS176	R596,597	OB01888A	RK 10K 1/4W J			
D511,512	OB06398A	SID 1SS176	R598	OB09701A	RK 10K 1/6W J			
D513	OB06398A	SID 1SS176	R599	OB09677A	RK 1K 1/6W J			
D514	OB12584A	SID 1N4148	R5100	OB09701A	RK 10K 1/6W J			
D515	OB06398A	SID 1SS176	R5101	OB01933A	RK 220 1/4W J			
X501	OB92006A	X'tal 7.2MHz	R5102	OB09725A	RK 100K 1/6W J			
X502	OB92014A	Ceramic Resonator 4MHz	R5103,5104	OB09701A	RK 10K 1/6W J			
L501	OB51274A	Coil 22μH	R5105,5106	OB09717A	RK 47K 1/6W J			
L502	OB51291A	Coil 47μH	R5107,5108	OB09717A	RK 47K 1/6W J			
R501	OB09677A	RK 1K 1/6W J	R5109	OB09717A	RK 47K 1/6W J			
R502	OB09661A	RK 220 1/6W J (TA-3/3A/30)	R5110,5111	OB09717A	RK 47K 1/6W J			
	OB09665A	RK 330 1/6W J (TA-3E)	R5112	OB09725A	RK 100K 1/6W J			
R503,504	OB09721A	RK 68K 1/6W J	R5113	OB09707A	RK 18K 1/6W J			
R505	OB09725A	RK 100K 1/6W J	R5114	OB01889A	RK 100K 1/4W J			
R506	OB01889A	RK 100K 1/4W J (TA-3/3A/3E)	R5115	OB09661A	RK 220 1/6W J			
R507	OB09725A	RK 100K 1/6W J	R5116	OB09657A	RK 150 1/6W J			
R508	OB01888A	RK 10K 1/4W J	R5117	OB01889A	RK 100K 1/4W J			
R509	OB09677A	RK 1K 1/6W J	C501	OB09288A	CC 1000P 50V K			
R510	OB09699A	RK 8.2K 1/6W J	C502	OB05899A	CE 220μ 10V			
R511	OB01888A	RK 10K 1/4W J	C503	OB09291A	CC 0.022μ 50V Z			
R512	OB00346A	RK 1K 1/2W J	C504	OB41900A	CC 39P 50V J (TA-3/3A/3E)			
R513	OB01888A	RK 10K 1/4W J	C505	OB41735A	CC 100P 50V J (TA-30)			
R514	OB01889A	RK 100K 1/4W J	C506	OB09586A	CC 2200P 50V K			
R515,516	OB09725A	RK 100K 1/6W J	C507	OB09290A	CC 0.01μ 50V Z			
R517	OB01889A	RK 100K 1/4W J	C508	OB01405A	CE 1μ 50V			
R518,519	OB09697A	RK 6.8K 1/6W J	C508	OB01400A	CE 100μ 16V			
R520,521	OB01857A	RK 1K 1/4W J	C509,510	OB09291A	CC 0.022μ 50V Z			
R522,523	OB09677A	RK 1K 1/6W J	C511	OB40067A	CE 470μ 10V			
R524,525	OB09677A	RK 1K 1/6W J	C512,513	OB41740A	CC 33P 50V J			
R526,527	OB09677A	RK 1K 1/6W J	C514	OB01405A	CE 1μ 50V			
R528,529	OB09677A	RK 1K 1/6W J	C515	OB40025A	CE 0.47μ 50V			
R530,531	OB09677A	RK 1K 1/6W J	C516	OB09327A	CE 0.33μ 50V			
R532	OB09677A	RK 1K 1/6W J	C517	OB41618A	CC 0.1μ 25V J			
			C518	OB40103A	CE 47μ 35V			
			C519,520	OB09793A	CC 30P 50V J			
			C521	OB09387A	CC 0.047μ 50V Z			

6.17. Logic P.C.B. Assy

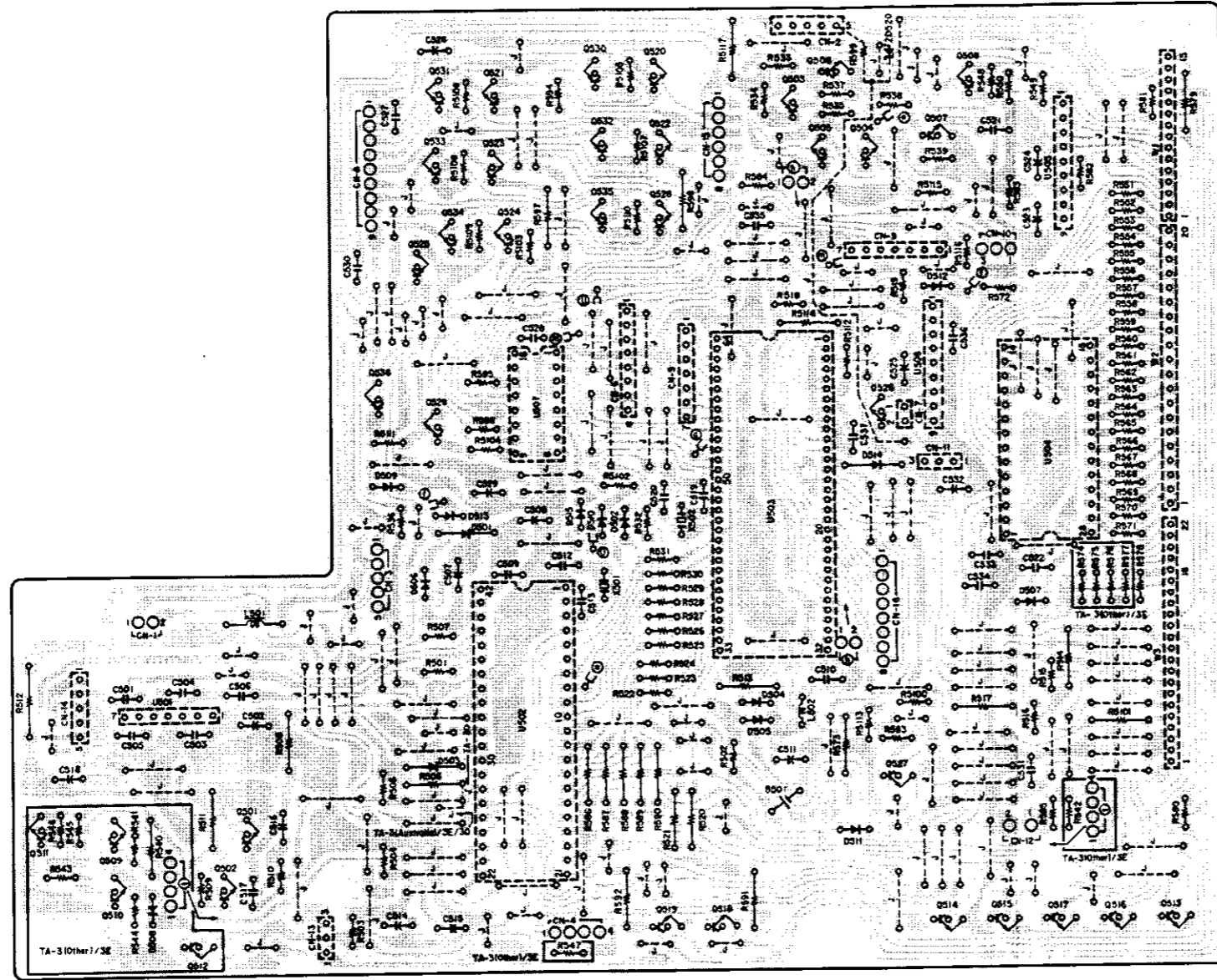

Fig. 6.17

6.18. Main P.C.B. Ass'y

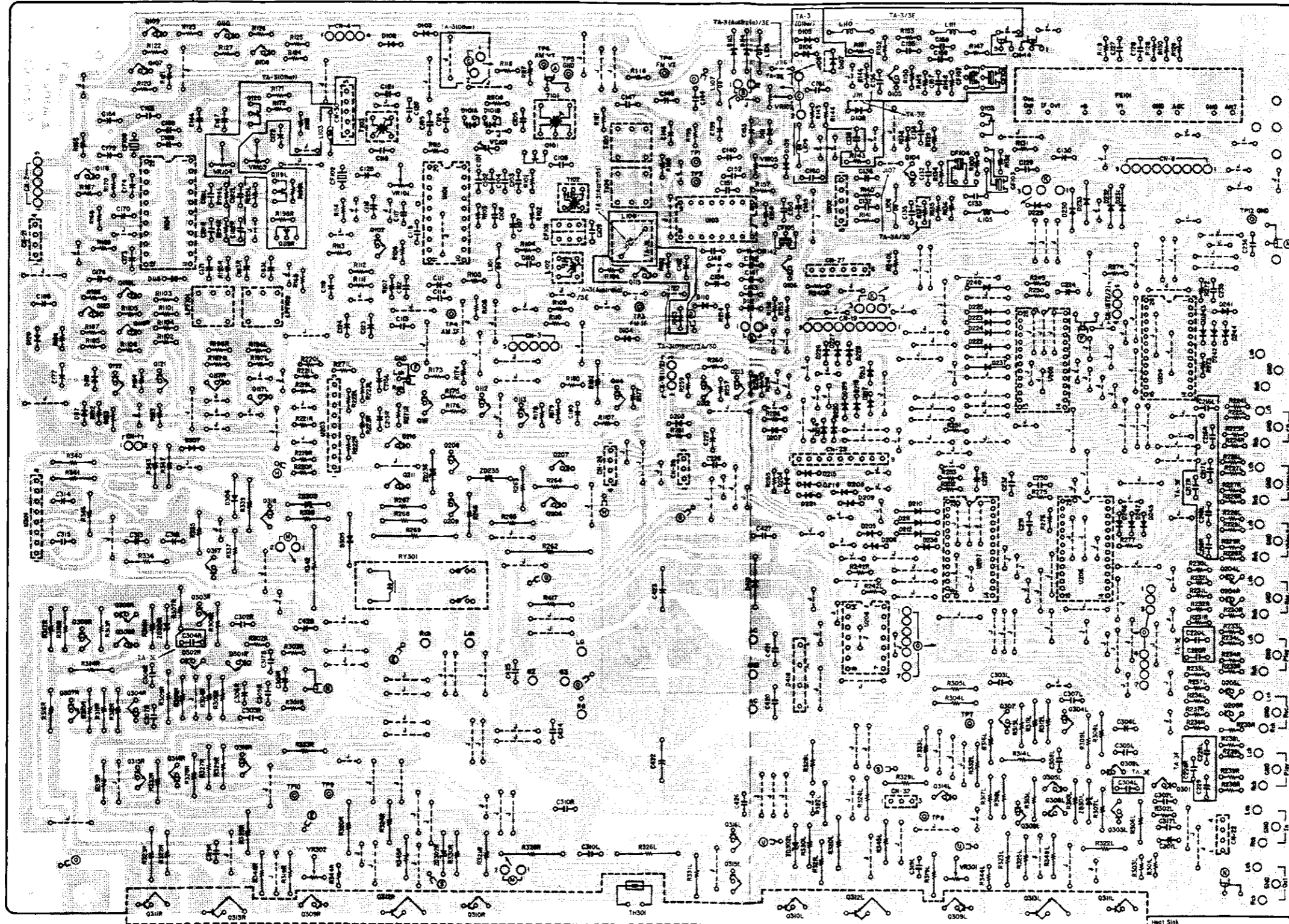

Fig. 6.18

Schematic Ref. No.	Part No.	Description
6.18. Main P.C.B. Ass'y		
	BA07419A	Main P.C.B. Ass'y (TA-3 (Other))
	BA07420A	Main P.C.B. Ass'y (TA-3 (Australia))
	BA07417A	Main P.C.B. Ass'y (TA-3A)
	BA07421A	Main P.C.B. Ass'y (TA-3E)
	BA07418A	Main P.C.B. Ass'y (TA-30)
	OB60634A	Main P.C.B.
U101	OB11243A	IC LA1247
U102	OB11156A	IC TA7060AP
U103	OB11157A	IC LA1235
U104	OB11245A	IC LA3400N
U203	OB11050A	IC NJM4558S
U204,205	OB11514A	IC LC7816
U206,207	OB11514A	IC LC7816
U208	OB11056A	IC LC4966
U301	OB11246A	IC μ PC1237H
Q101	OB06129A	FET 2SK117 (Y)
Q102	OB06100A	TR 2SC945 (K,P,Q)
Q103	OB10127A	FET 2SK241 (GR)
Q104	OB06115A	TR 2SC1675
Q105	OB06115A	TR 2SC1675 (TA-3/3E)
Q106	OB06100A	TR 2SC945 (K,P,Q)
Q107	OB10097A	TR 2SA952
Q108	OB06100A	TR 2SC945 (K,P,Q)
Q109	OB10097A	TR 2SA952
Q110,111	OB06100A	TR 2SC945 (K,P,Q)
Q112,113	OB06100A	TR 2SC945 (K,P,Q)
Q114	OB06013A	TR 2SA733 (P,Q)
Q115	OB06100A	TR 2SC945 (K,P,Q) (TA-3 (Australia)/3E)
Q116	OB06100A	TR 2SC945 (K,P,Q)
Q117L,R	OB06299A	TR 2SC2878
Q118L,R	OB06013A	TR 2SA733 (P,Q)
Q119L,R	OB10151A	FET 2SK364 (TA-3 (Other))
Q120	OB10151A	FET 2SK364 (TA-3 (Other))
Q121,122	OB06100A	TR 2SC945 (K,P,Q)
Q123	OB06013A	TR 2SA733 (P,Q)
Q204L,R	OB06299A	TR 2SC2878
Q205L,R	OB06299A	TR 2SC2878
Q206	OB10248A	TR 2SD313 (E)
Q207	OB10267A	TR 2SD1408
Q208	OB06013A	TR 2SA733 (P,Q)
Q209	OB06100A	TR 2SC945 (K,P,Q)
Q210	OB10266A	TR 2SB1017
Q211	OB10264A	TR 2SB507 (E)
Q212	OB06100A	TR 2SC945 (K,P,Q)
Q213	OB06013A	TR 2SA733 (P,Q)
Q301L,R	OB06142A	TR 2SC2240 (BL)
Q302L,R	OB06142A	TR 2SC2240 (BL)
Q303L,R	OB06142A	TR 2SC2240 (BL)
Q304L,R	OB10204A	TR 2SA1145
Q305L,R	OB10205A	TR 2SC2705
Q306L,R	OB06142A	TR 2SC2240 (BL)
Q307L,R	OB10205A	TR 2SC2705
Q308L,R	OB10204A	TR 2SA1145
Q314L,R	OB10050A	TR 2SA970 (BL)
Q315L,R	OB10205A	TR 2SC2705
Q316L,R	OB10050A	TR 2SA970 (BL)
Q317	OB06322A	TR 2SC2002
Q318	OB06372A	TR 2SA953
ZD235,236	OB12627A	ZD 18V RD18EB2
ZD301L,R	OB06298A	ZD 8.2V RD8.2EB2
ZD302L,R	OB12614A	ZD 12V RD12EB2
ZD303	OB12614A	ZD 12V RD12EB2
D101	OB12606A	Varicap KV1236Z1
D102,103	OB06398A	SID 1SS176
D104	OB06398A	SID 1SS176
D105,106	OB06398A	SID 1SS176 (TA-3 (Other))
D107,108	OB06398A	SID 1SS176 (TA-3 (Other))
D109,110	OB06398A	SID 1SS176
D111,112	OB06398A	SID 1SS176
D113,114	OB12584A	SID 1N4148
D115	OB06398A	SID 1SS176
D117,118	OB06398A	SID 1SS176
D120	OB06398A	SID 1SS176

Schematic Ref. No.	Part No.	Description	Schematic Ref. No.	Part No.	Description	Schematic Ref. No.	Part No.	Description	Schematic Ref. No.	Part No.	Description	Schematic Ref. No.	Part No.	Description	Schematic Ref. No.	Part No.	Description
D203,204	OB06398A	SID 1SS176	R121	OB09701A	RK 10K 1/6W J	R221L,R	OB09725A	RK 100K 1/6W J	R345L,R	OB24215A	RC 0.47 5W	C216L,R	OB05550A	CML 1000P 50V J (TA-3E)	O-O	OB83518A	Ribbon Wire 7P 120
D205,206	OB06398A	SID 1SS176	R122	OB09717A	RK 47K 1/6W J	R222L,R	OB09725A	RK 100K 1/6W J	R346	OB09391A	RK 91K 1/4W J	C217L,R	OB05550A	CML 1000P 50V J (TA-3E)	Q-Q	OB83527A	Lead Wire 180
D207,208	OB06398A	SID 1SS176	R123,124	OB09701A	RK 10K 1/6W J	R223L,R	OB09657A	RK 150K 1/6W J	R347	OB01889A	RK 100K 1/4W J	C218L,R	OB05550A	CML 1000P 50V J (TA-3E)	S-S	OB83525A	Lead Wire 160 (TA-3/3A/3E)
D209	OB06398A	SID 1SS176	R125,126	OB09701A	RK 10K 1/6W J	R224L,R	OB09645A	RK 47 1/6W J	R348L,R	OB24215A	RC 0.47 5W	C220L,R	OB05550A	CML 1000P 50V J (TA-3E)		OB83535A	Lead Wire 160 (TA-30)
D210,211	OB12584A	SID 1N4148	R127	OB09701A	RK 10K 1/6W J	R225L,R	OB09719A	RK 56K 1/6W J	R417	OB05615A	RK 22K 1/4W J	C222L,R	OB05550A	CML 1000P 50V J (TA-3E)	U-U	OB83538A	Lead Wire 80 (TA-30)
D212	OB12584A	SID 1N4148	R128	OB09725A	RK 100K 1/6W J	R226L,R	OB09645A	RK 47 1/6W J	R1101,1102	OB09695A	RK 5.6K 1/6W J	C224,225	OB09372A	CE 2.2μ 50V		OB80208A	Glass Tube 10mm (28)
D213,214	OB06398A	SID 1SS176	R129	OB09727A	RK 120K 1/6W J	R227L,R	OB09719A	RK 56K 1/6W J	R1103,1104	OB09701A	RK 10K 1/6W J	C226	OB09292A	CC 0.1μ 50V Z		OB80209A	Glass Tube 16mm (4)
D215,216	OB06398A	SID 1SS176	R130	OB09721A	RK 68K 1/6W J	R228L,R	OB09645A	RK 47 1/6W J	R1105,1106	OB09701A	RK 10K 1/6W J	C227	OB01527A	CC 22μ 25V		OB80210A	Glass Tube 10mm (2)
D217,218	OB06398A	SID 1SS176	R131	OB09745A	RK 680K 1/6W J	R229L,R	OB09719A	RK 56K 1/6W J	R1107,1108	OB09725A	RK 100K 1/6W J	C228L,R	OB05550A	CML 1000P 50V J (TA-3E)		OB81977A	ANT Terminal F (1)
D219,220	OB06398A	SID 1SS176	R132	OB09661A	RK 220 1/6W J	R230L,R	OB09661A	RK 220 1/6W J	VC101	OB42010A	C Trimmer 10P	C229	OB09292A	CC 0.1μ 50V Z (TA-3E)		OB81981A	4P Pin Jack (5)
D221	OB06398A	SID 1SS176	R133	OB09667A	RK 390 1/6W J	R231L,R	OB09725A	RK 100K 1/6W J	C101	OB09288A	CC 1000P 50V K	C230	OB09291A	CC 0.022μ 50V Z		OB83547A	4P Pin Jack (1)
D222,223	OB12584A	SID 1N4148	R134	OB09698A	RM 7.5K 1/6W F	R232L,R	OB09717A	RK 47K 1/6W J	C102,103	OB09291A	CC 0.022μ 50V Z	C231,232	OB09292A	CC 0.1μ 50V Z			
D224,225	OB12584A	SID 1N4148	R135	OB09686A	RM 2.4K 1/6W F	R233L,R	OB09645A	RK 47 1/6W J	C104	OB09288A	CC 1000P 50V K	C235	OB09291A	CC 0.022μ 50V Z			
D226,227	OB06398A	SID 1SS176	R136	OB09665A	RK 330 1/6W J (TA-3A/30)	R234L,R	OB09719A	RK 56K 1/6W J	C105,106	OB09291A	CC 0.022μ 50V Z	C236	OB01780A	CML 0.022μ 50V J (TA-3/3A/30)			
D228,229	OB06398A	SID 1SS176	R137	OB09665A	RK 47 1/6W J	R235L,R	OB09661A	RK 220 1/6W J	C107	OB01403A	CE 47μ 16V	C236	OB01780A	CML 0.022μ 50V J (TA-3/3A/30)			
D230	OB12584A	SID 1N4148	R138	OB09645A	RK 47 1/6W J	R236L,R	OB09725A	RK 100K 1/6W J	C108	OB09291A	CC 0.022μ 50V Z	C236	OB01780A	CML 0.022μ 50V J (TA-3/3A/30)			
D231,282	OB12584A	SID 1N4148	R139	OB09667A	RK 390 1/6W J	R237L,R	OB09733A	RK 220K 1/6W J	C109	OB041908A	CC 82P 50V J	C236	OB01780A	CML 0.022μ 50V J (TA-3/3A/30)			
D233	OB12584A	SID 1N4148	R140,141	OB09667A	RK 390 1/6W J	R238L,R	OB09645A	RK 47 1/6W J	C110	OB09291A	CC 0.022μ 50V Z	C236	OB01780A	CML 0.022μ 50V J (TA-3/3A/30)			
D237	OB12584A	SID 1N4148	R142	OB09665A	RK 330 1/6W J	R239L,R	OB09719A	RK 56K 1/6W J	C111	OB09288A	CC 1000P 50V K	C236	OB01780A	CML 0.022μ 50V J (TA-3/3A/30)			
D238	OB06398A	SID 1SS176	R143	OB09689A	RK 3.3K 1/6W J (TA-3 (Other))	R240L,R	OB09733A	RK 220K 1/6W J	C112	OB05582A	CML 0.022μ 50V J	C236	OB01780A	CML 0.022μ 50V J (TA-3/3A/30)			
D240	OB12584A	SID 1N4148	R144	OB09665A	RK 330 1/6W J (TA-3 (Other))	R242L,R	OB09679A	RK 1.2K 1/6W J	C113	OB01802A	CML 2200P 50V J	C301L,R	OB09148A	CE 10μ 25V (LN)			
D241,242	OB06398A	SID 1SS176	R145,146	OB09693A	RK 4.7K 1/6W J (TA-3 (Other))	R249	OB09733A	RK 220K 1/6W J	C114	OB05685A	CML 0.082μ 50V J	C302L,R	OB09292A	CC 0.1μ 50V Z			
D243,244	OB06398A	SID 1SS176	R147,148	OB09665A	RK 330 1/6W J (TA-3/3E)	R250,251	OB09705A	RK 15K 1/6W J	C115	OB09290A	CC 0.01μ 50V Z	C303L,R	OB05652A	CML 4700P 50V J			
D245,246	OB06398A	SID 1SS176	R149	OB09698A	RK 7.5K 1/6W J (TA-3/3E)	R252	OB09725A	RK 100K 1/6W J	C116	OB40025A	CE 0.47μ 50V	C304L,R	OB09286A	CC 470P 50V J (TA-3E)			
D247	OB06398A	SID 1SS176	R150	OB09689A	RK 3.3K 1/6W J (TA-3/3E)	R253	OB09733A	RK 220K 1/6W J	C117	OB09291A	CC 0.022μ 50V Z						
D304	OB12584A	SID 1N4148	R151	OB09671A	RK 560 1/6W J (TA-3/3E)	R254	OB09717A	RK 47K 1/6W J	C118	OB01403A	CE 47μ 16V	C305L,R	OB05681A	CML 0.01μ 50V J			
D305	OB12584A	SID 1N4002	R152	OB09646A	RK 51 1/6W J (TA-3/3E)	R255,256	OB09705A	RK 15K 1/6W J	C119	OB09291A	CC 0.022μ 50V Z	C306L,R	OB40434A	CC 220μ 25V (LN)			
D307	OB06398A	SID 1SS176	R153	OB09677A	RK 1K 1/6W J (TA-3/3E)	R257	OB09717A	RK 47K 1/6W J	C120	OB41896A	CSP 390P 50V J	C307L,R	OB09279A	CC 22P 50V K			
D418	OB12626A	SID KBU6D	R154,155	OB09717A	RK 47K 1/6W J	R258,259	OB09701A	RK 10K 1/6W J	C121	OB41489A	CC 2P 50V J	C308L,R	OB09279A	CC 22P 50V K			
D419	OB12586A	SID 1N4002	R156	OB09701A	RK 10K 1/6W J	R260	OB09713A	RK 33K 1/6W J	C123,124	OB40029A	CE 4.7μ 50V	C310L,R	OB01780A	CML 0.1μ 50V J			
CF101	OB41897A	Ceramic Filter SFZ450G3L	R157	OB09701A	RK 10K 1/6W J	R261	OB09727A	RK 120K 1/6W J	C125	OB09372A	CE 2.2μ 50V	C313	OB09372A	CE 2.2μ 50V			
CF102	OB41898A	Ceramic Filter BFU450C4N	R158	OB09701A	RK 10K 1/6W J	R262	OB24204A	RF 220 2W	C126	OB09291A	CC 0.022μ 50V Z	C314	OB01400A	CE 100μ 16V			
CF103,104	OB41918A	Ceramic Filter SFE10.7MLA	R159	OB09701A	RK 10K 1/6W J	R263	OB05622A	RK 2.2K 1/4W J	C127	OB09387A	CC 0.47μ 50V Z	C315	OB40250A	CE 100μ 16V (BP)			
CF105	OB41918A	Ceramic Filter SFE10.7MLA	R160	OB09701A	RK 10K 1/6W J	R264	OB05794A	RK 680 1/4W J	C128,129	OB09291A	CC 0.022μ 50V Z	C316	OB01674A	CE 10μ 25V			
CF106,107	OB41928A	Ceramic Filter SFE10.7MLA	R161	OB09701A	RK 10K 1/6W J	R265	OB05622A	RK 2.2K 1/4W J	C130	OB40079A	CC 220μ 16V	C317L,R	OB05681A	CML 0.01μ 50V J			
CF108	OB41927A	Ceramic Resonator CSB456F11	R162	OB09745A	RK 680K 1/6W J (TA-3 (Australia)/3E)	R266,267	OB05622A	RK 2.2K 1/4W J	C132	OB09291A	CC 0.022μ 50V Z	C319L,R	OB41176A	CML 0.22μ 63V J			
T101	OB51269A	Coil AM ANT	R163	OB09693A	RK 4.7K 1/6W J (TA-3 (Australia)/3E)	R268	OB05794A	RK 680 1/4W J	C133,134	OB09291A	CC 0.022μ 50V Z	C420,421	OB41901A	CC 0.047μ 500V Z			
T102	OB51271A	Coil AM IFT	R164	OB09687A	RK 2.7K 1/6W J (TA-3 (Australia)/3E)	R269	OB24204A	RF 220 2W	C135,136	OB09291A	CC 0.022μ 50V Z	C422,423	OB40519A	CC 10000μ 63V			
T103	OB51270A	Coil AM OSC	R165	OB09717A	RK 47K 1/6W J	R270	OB09725A	RK 100K 1/6W J	C137,138	OB09291A	CC 0.022μ 50V Z	C424,425	OB41476A	CML 0.1μ 63V J			
T104	OB51293A	Coil FM DET A	R166	OB09701A	RK 10K 1/6W J	R271L,R	OB09733A	RK 220K 1/6W J	C139	OB40079A	CC 220μ 16V	C426,427	OB41476A	CML 0.1μ 63V J			
T105	OB51294A	Coil FM DET B	R167	OB09717A	RK 47K 1/6W J	R272	OB09705A	RK 15K 1/6W J	C140,141	OB09291A	CC 0.022μ 50V Z	C428	OB40029A	CE 4.7μ 50V			
L101	OB51274A	Coil 22μH	R168	OB09701A	RK 10K 1/6W J	R273	OB09705A	RK 15K 1/6W J	C142,143	OB09291A	CC 0.022μ 50V Z	RY301	OB90331A	Relay VB 24V			
L102	OB51292A	Coil AM IFT(A)	R169	OB09689A	RK 3.3K 1/6W J	R274	OB09725A	RK 100K 1/6W J	C144	OB09291A	CC 0.022μ 50V Z	FE101	OB91027A	Front End (TA-3/3A)			
L103	OB51274A	Coil 22μH	R170	OB09749A	RK 1M 1/6W J (TA-3 (Other))	R275	OB09733A	RK 220K 1/6W J	C145	OB01405A	CE 1μ 50V						
L104,105	OB51274A	Coil 22μH	R171	OB09749A	RK 1M 1/6W J (TA-3 (Other))	R276	OB09725A	RK 100K 1/6W J	C146	OB40080A	CE 330μ 16V						
L106,107	OB51274A	Coil 22μH	R172	OB09725A	RK 100K 1/6W J (TA-3 (Other))	R277	OB09705A	RK 15K 1/6W J	C147	OB09291A	CC 0.022μ 50V Z						
L108	OB51289A	L.P. Filter (TA-3E)	R173	OB09725A	RK 100K 1/6W J	R301L,R	OB09733A	RK 220K 1/6W J	C148	OB41735A	CC 100P 50V J (TA-3E)						
L109	OB51274A	Coil 22μH (TA-3 (Other))	R174,175	OB09701A	RK 10K 1/6W J	R302L,R	OB09669A	RK 470 1/6W J	C149	OB01405A	CE 1μ 50V	CN1	OB83491A	2P Connector Ass'y 300			
L110,111	OB51274A	Coil 22μH (TA-3/3E)	R176,177	OB09701A	RK 10K 1/6W J	R303L,R	OB22379A	RM 22.0K 1/4W F	C150,151	OB09291A	CC 0.022μ 50V Z	CN2	OB83500A	5P Connector Ass'y 300			
LPF101,102	OB51295A	Coil FM MPX Trap	R178,179	OB09701A	RK 10K 1/6W J	R304L,R	OB22635A	RM 1.21K 1/4W F	C152	OB09291A	CC 0.022μ 50V Z	CN3	OB83501A	5P Connector Ass'y 200			
VR101	OB32130A	Semi VR 100K	R180	OB09701A	RK 10K 1/6W J	R305L,R	OB09653A	RK 100 1/6W J	C153	OB40029A	CE 4.7μ 50V	CN4	OB83495A	4P Connector Ass'y 150			
VR102	OB32127A	Semi VR 10K	R181	OB09725A	RK 100K 1/6W J (TA-3 (Other))	R306L,R	OB01683A	RK 15K 1/4W J	C154	OB09372A	CE 2.2μ 50V	CN8	OB83679A	9P Connector Ass'y 300			
VR103	OB32130A	Semi VR 100K	R182	OB09707A	RK 18K 1/6W J	R307L,R	OB05691A	RK 390 1/4W J	C155,156	OB09291A	CC 0.022μ 50V Z (TA-3/3E)	CN14	OB83499A	5P Connector Ass'y 200			
VR104	OB32130A	Semi VR 100K (TA-3 (Other))	R183,184	OB09701A	RK 10K 1/6W J	R308L,R	OB22250A	RM 1.60K 1/4W F	C157,158								

7. SCHEMATIC DIAGRAMS

7.1. IC Block Diagrams

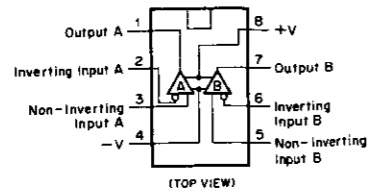

Fig. 7.1.1 Operational Amp. IC NJM4558DD, 072DE

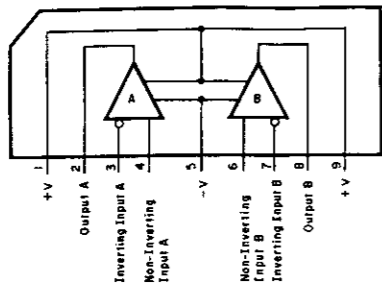

Fig. 7.1.2 Operational Amp. IC NJM4558S, μPC4570HA

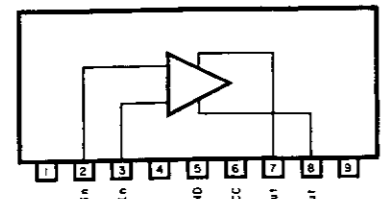

Fig. 7.1.3 Volume Motor Driver IC BA6208

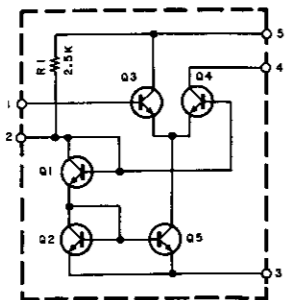

Fig. 7.1.4 FM IF Amp. IC TA7060AP

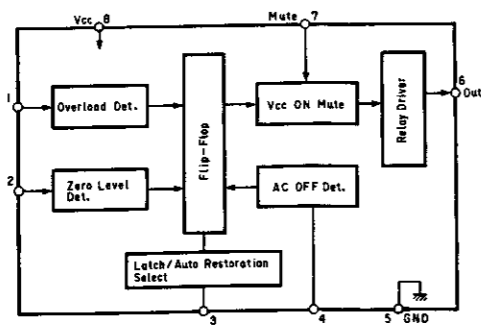

Fig. 7.1.5 Power Amp. Protector IC μPC1237H

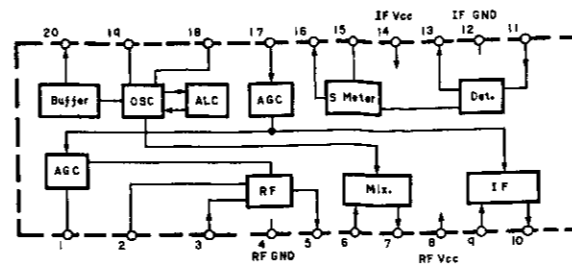

Fig. 7.1.6 AM Tuner IC LA1247

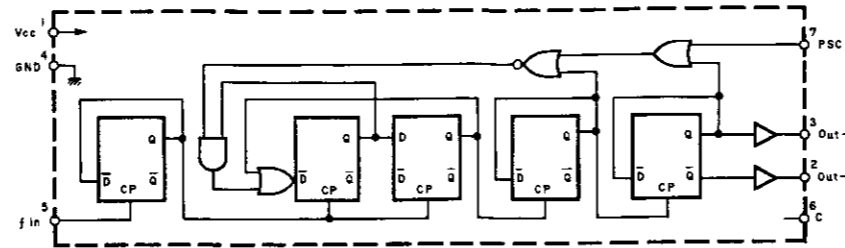

Fig. 7.1.7 ECL Prescaler (FM) IC TD6104P

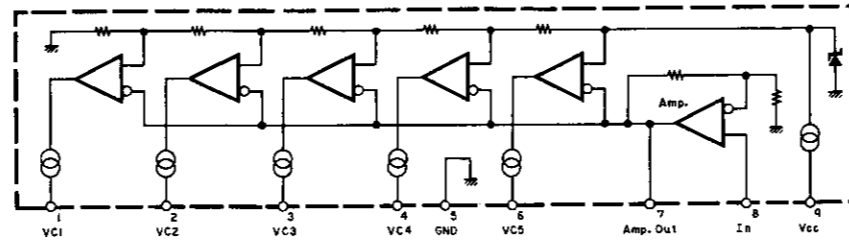

Fig. 7.1.8 Signal Meter Driver IC LB1413N

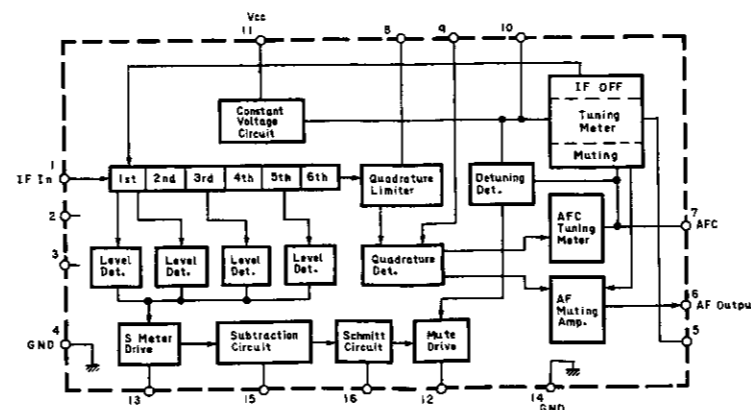

Fig. 7.1.9 FM IF Amp. & Detector IC LA1235

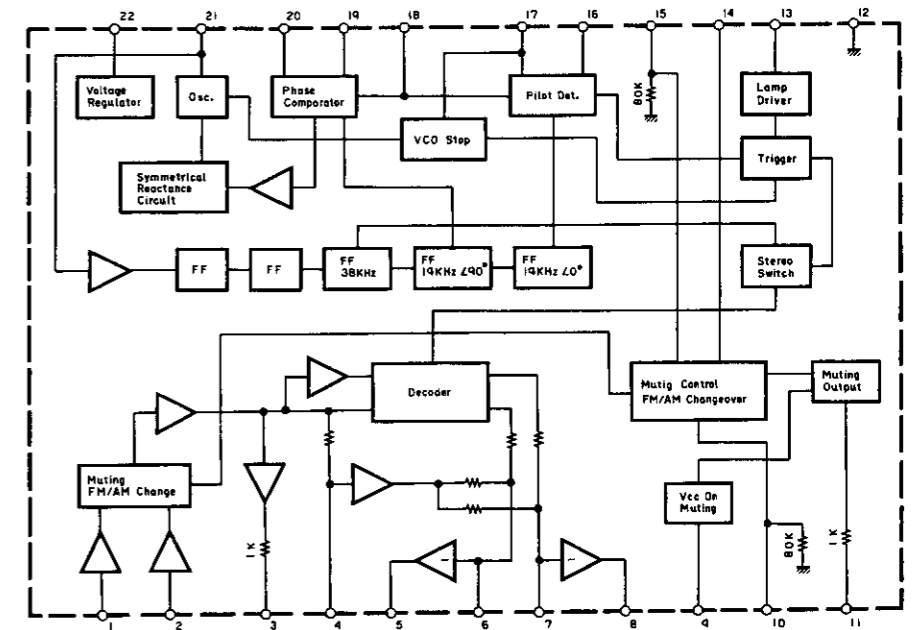

Fig. 7.1.10 PLL FM MPX Demodulator IC LA3400N

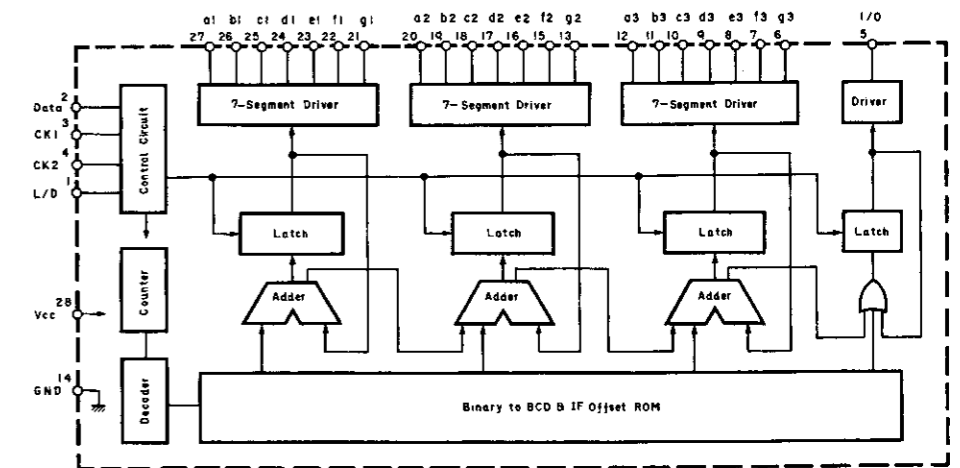

Fig. 7.1.11 Display Driver IC TD6301AP

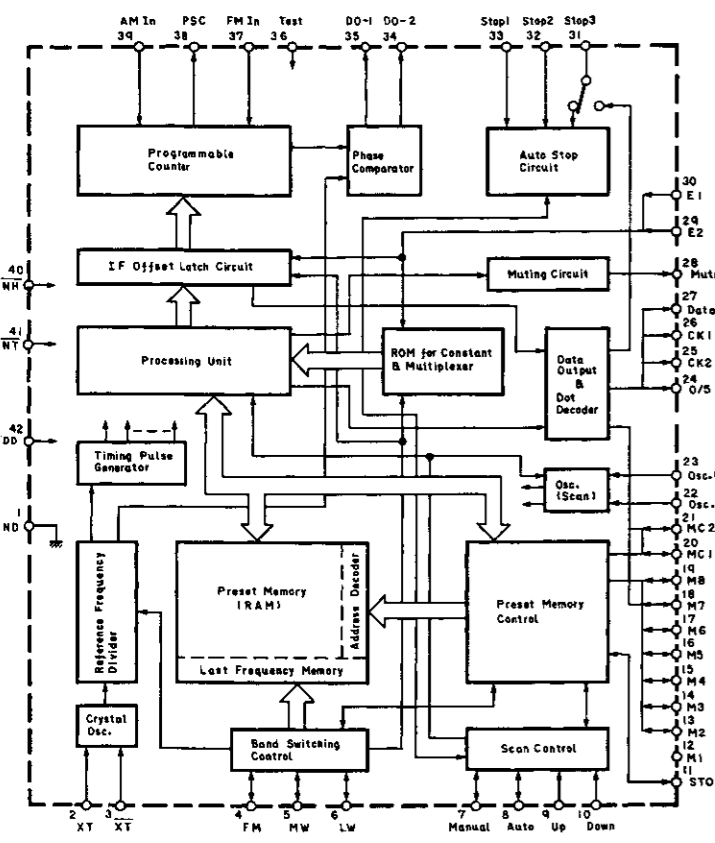

Fig. 7.1.12 PLL Synthesizer IC TC9147BP

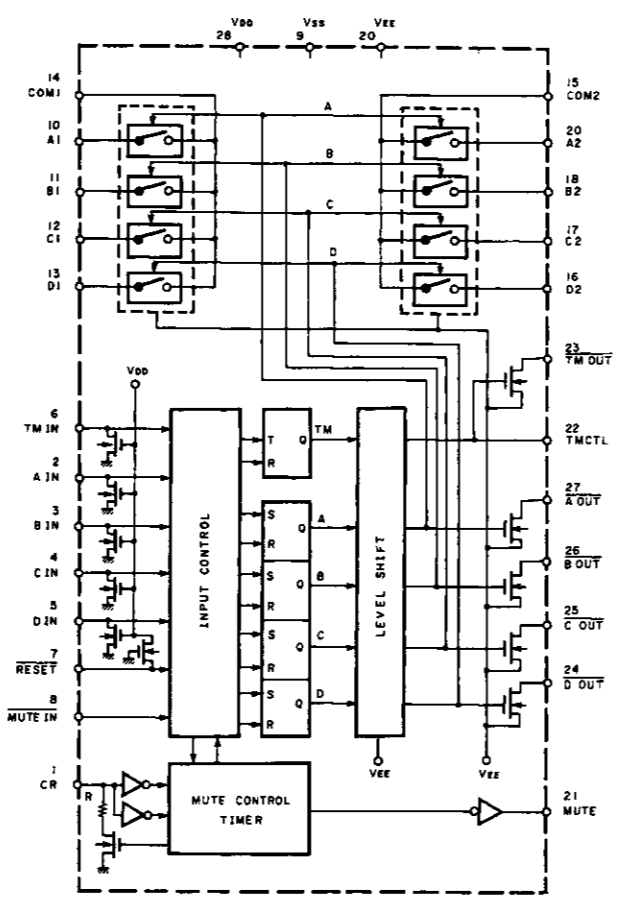

Fig. 7.1.14 Analog Function Switch LC7816

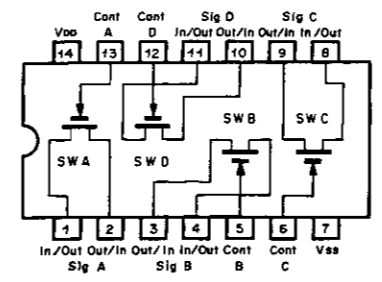

Fig. 7.1.15 Bilateral Switch IC TC4066BP, LC4966

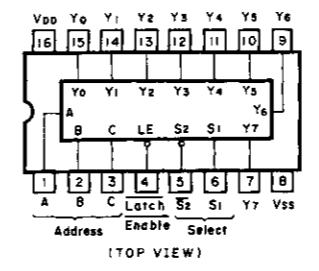

Fig. 7.1.16 3-to-8 Line Decoder IC μPD74HC237C

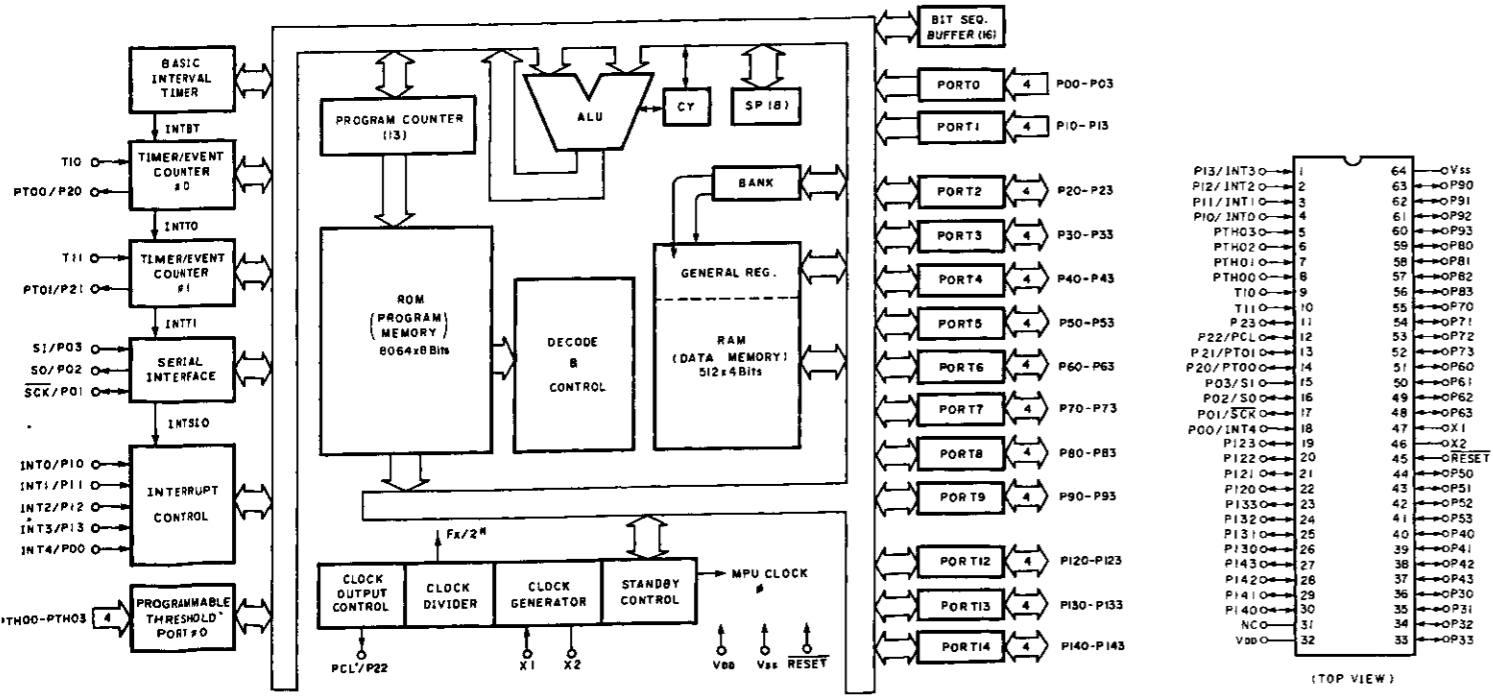
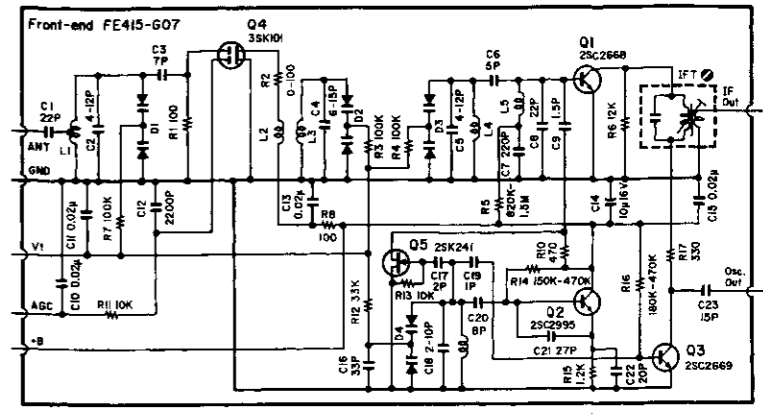
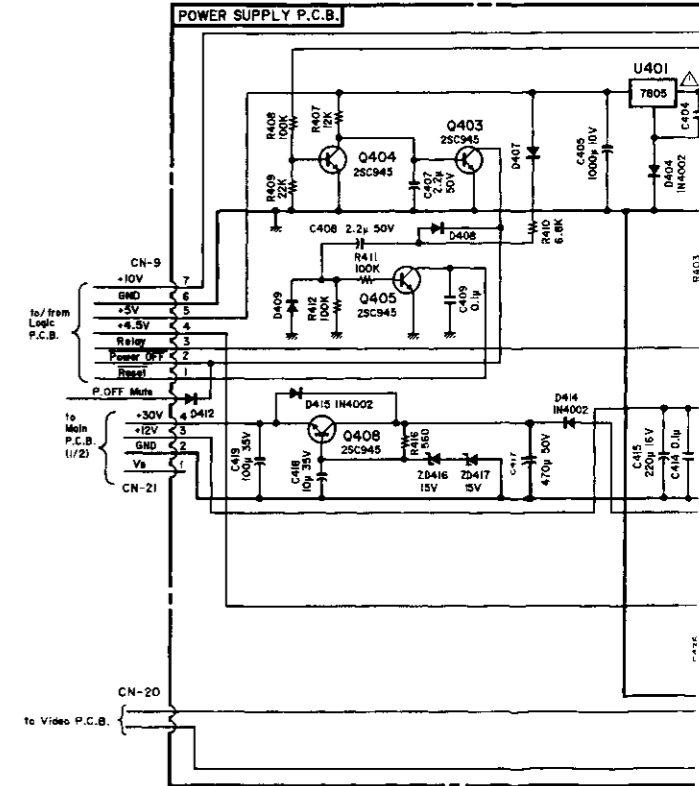

Fig. 7.1.13 MPU μPD75104CW

7.2. Schematic Diagrams



FM Front-end for TA-3E



Power supply P.C.B. Ass'y

7.2. Schematic Diagrams

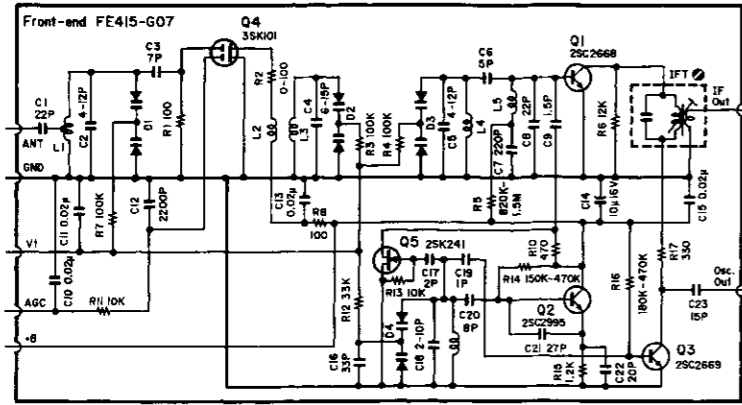

FM Front-end for TA-3E

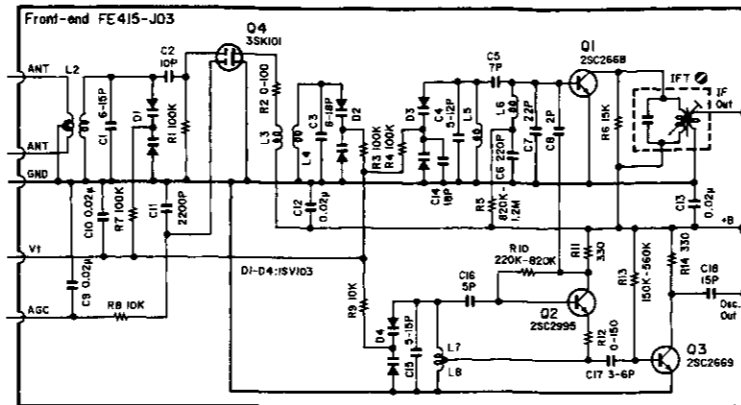

FM Front-end for TA-30

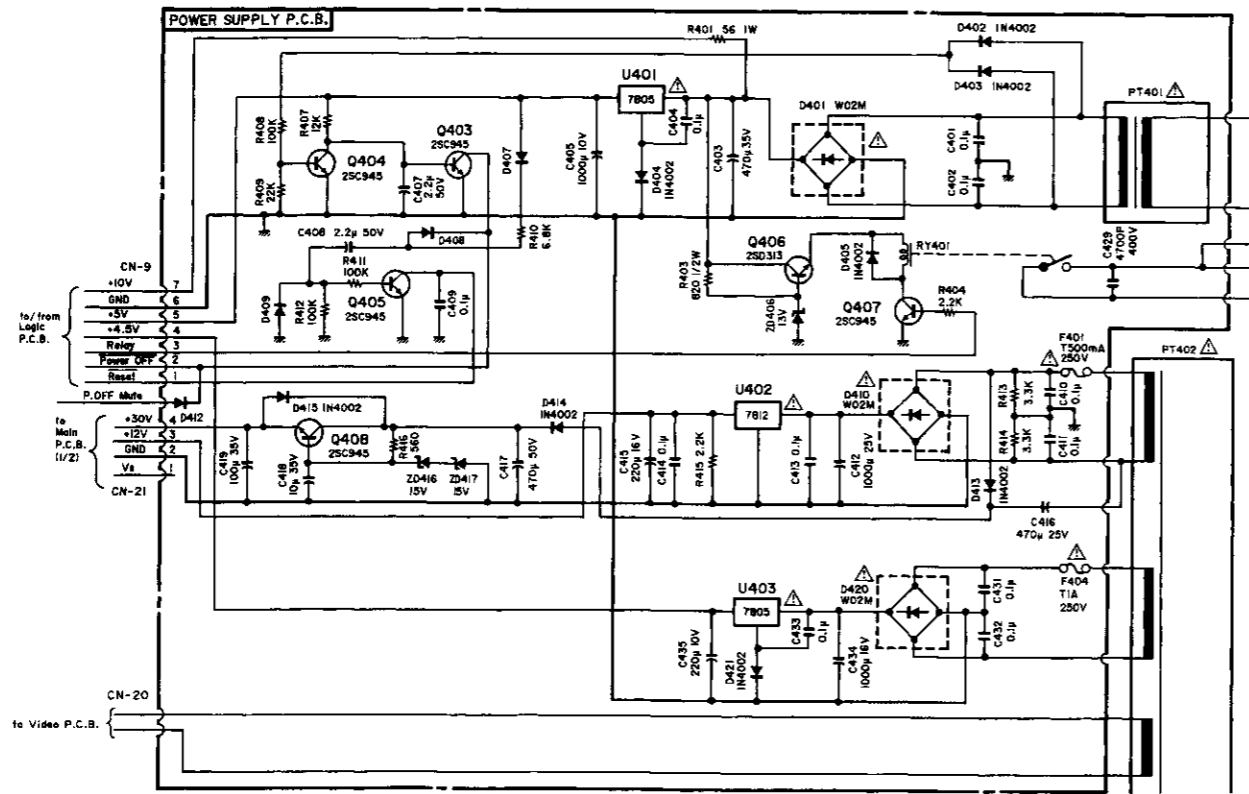

Power Supply P.C.B. Ass'y for TA-3 (Other)

7.2.1. Video Section

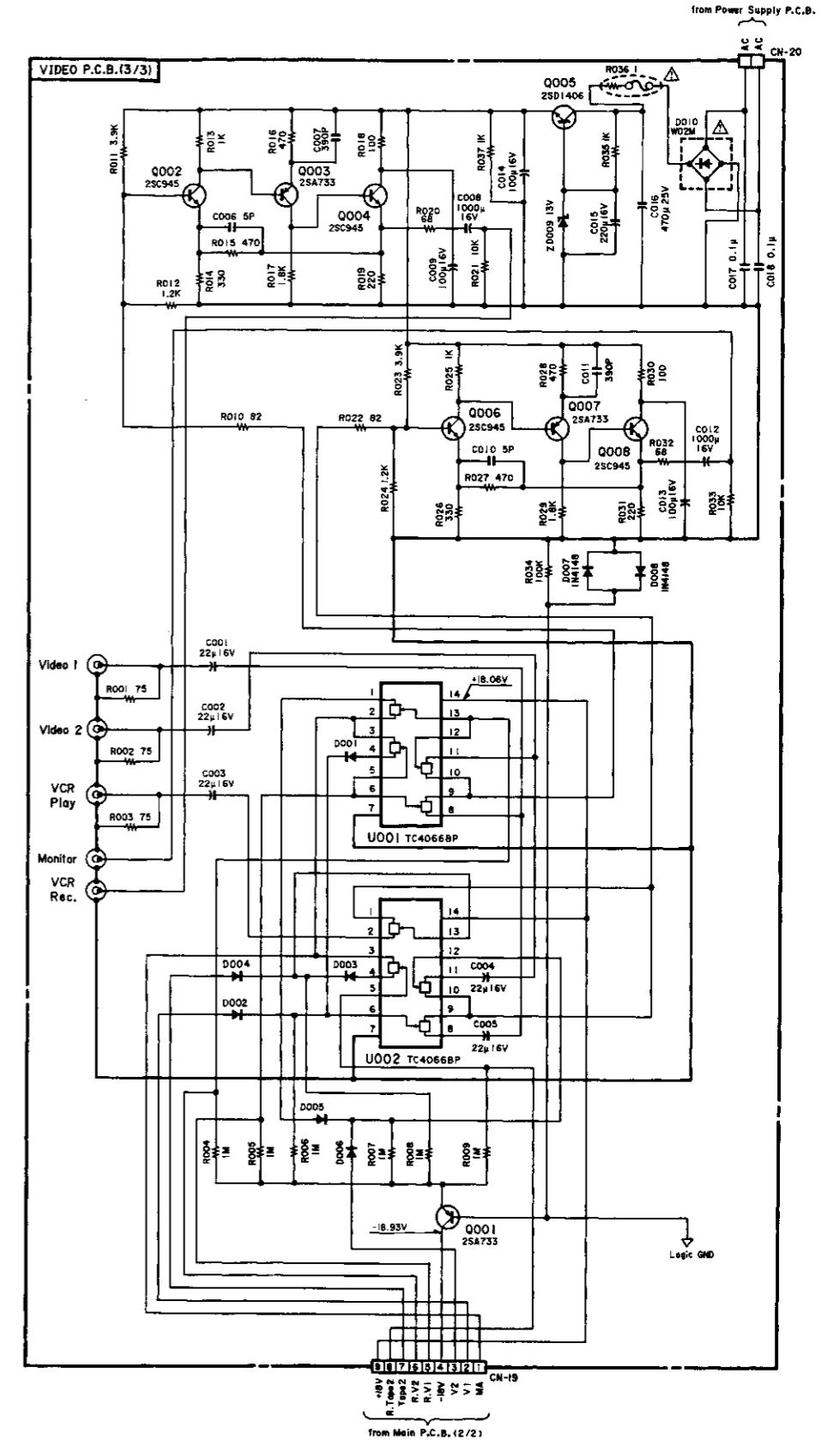

Fig. 7.2.1

7.2.2. Tuner Section

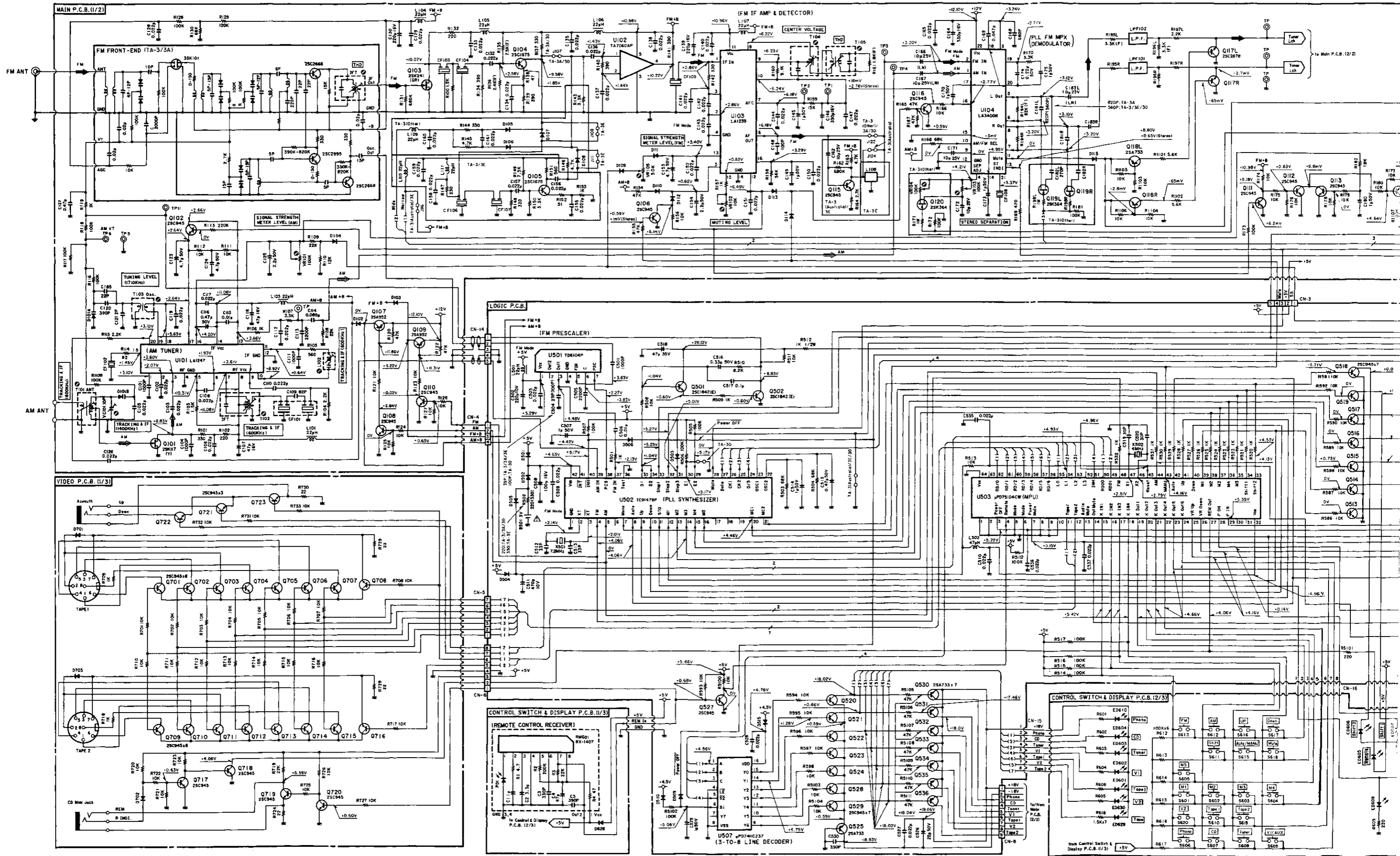
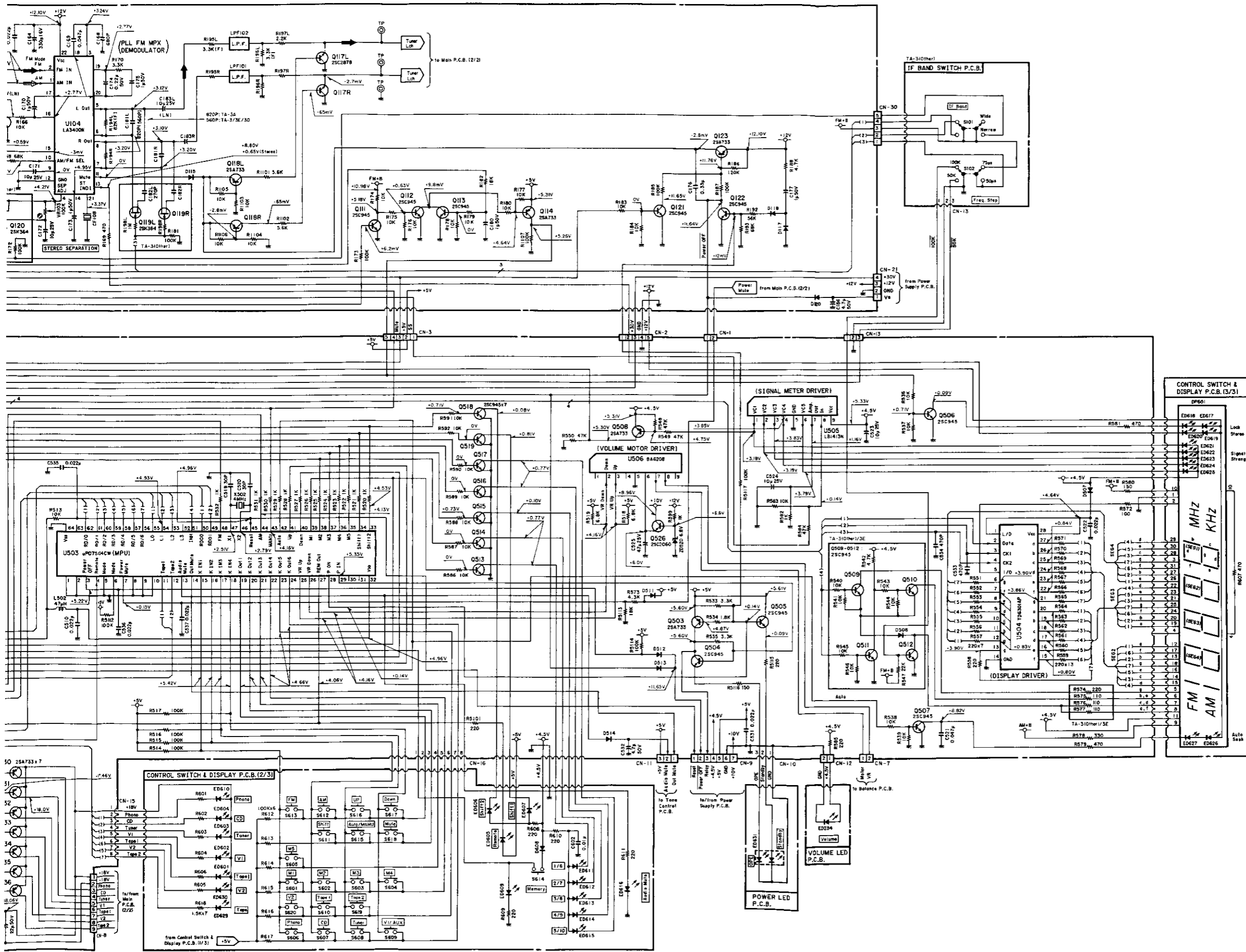



Fig. 7.2.2



- 

2SA733

2SA952

2SA953

2SA970

2SC945

2SC1675

2SC1842

2SC2002

2SC2240

2SC2878
- 

2SA1145

2SC2060

2SC2705
- 

2SB772
- 

2SA1492

2SC8856
- 

2SB1017

2SD1406

2SD1408
- 

2SB507

2SD313
- 

2SA957

2SC2167
- 

2SK241
- 

2SK117

2SK364
- 

2SK240
- 

1M (4V)

GND OUT

μPC7805H

μPC7812H

- Notes:
1. Diode is 1SS53, 1S1555, 1S1176, or 1N4148* unless otherwise specified.
 2. 2SA733, 2SA608SP, 2SA1048 and 2SA1175 are interchangeable with each other.
 3. 2SC945, 2SC536SP, 2SC2458 and 2SC2785 are interchangeable with each other.
 4. Parts marked with ** indicate those for TA-3E.
 5. Voltage measuring conditions
 - With no input signal applied to the input terminals.
 - With no load connected to the speaker terminals.

Fig. 7.2.2

7.2.3. Amplifier Section

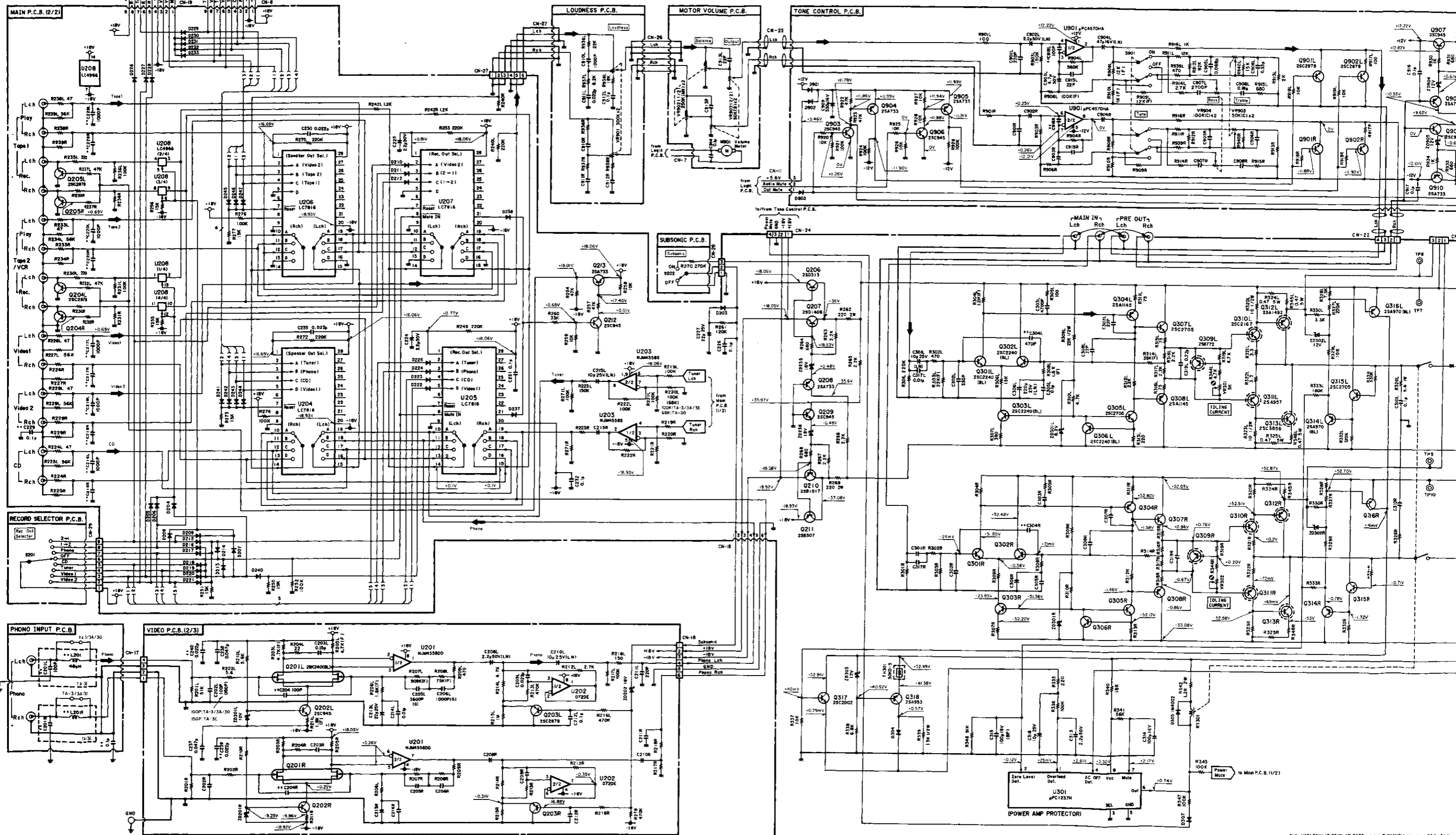
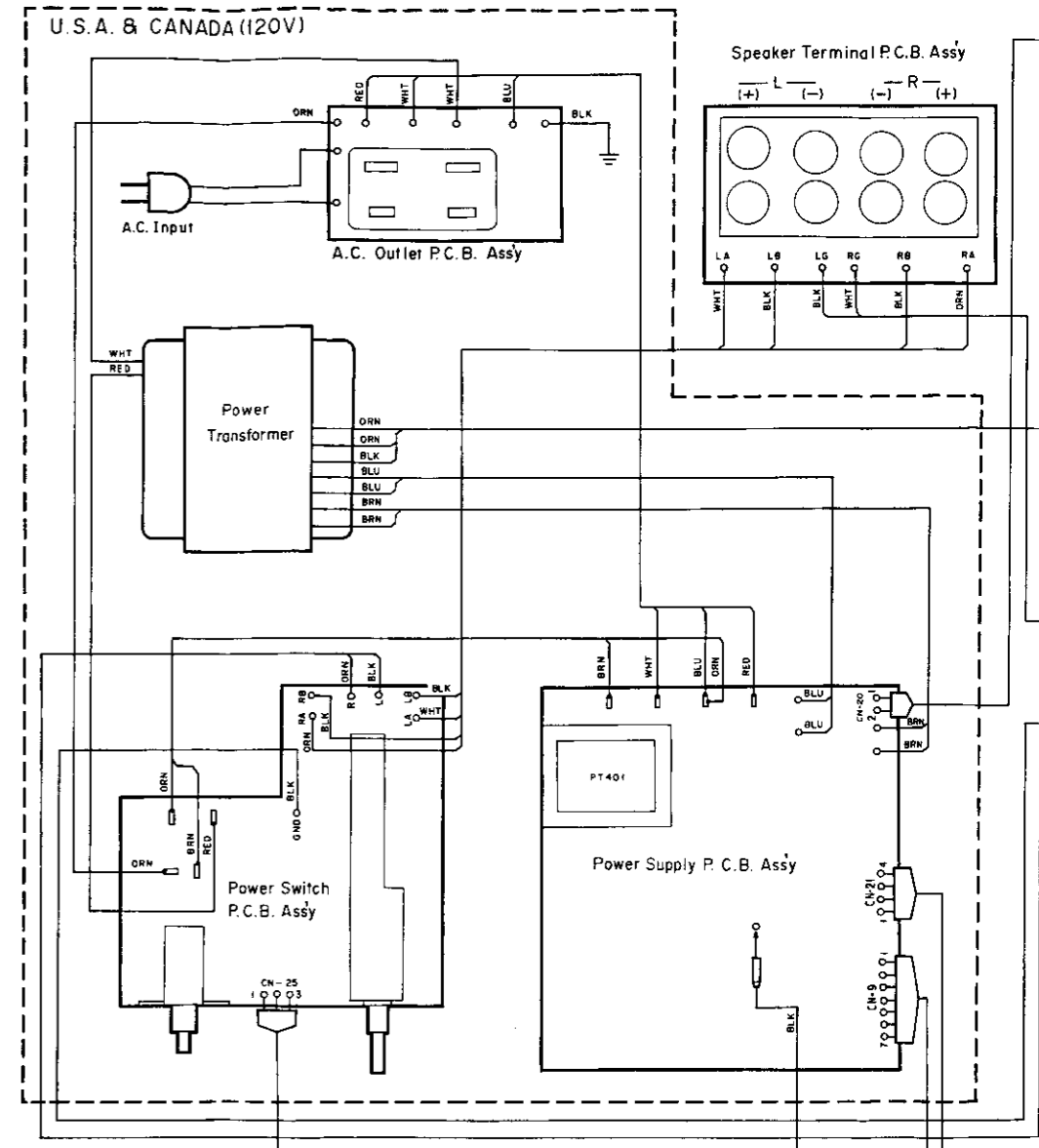
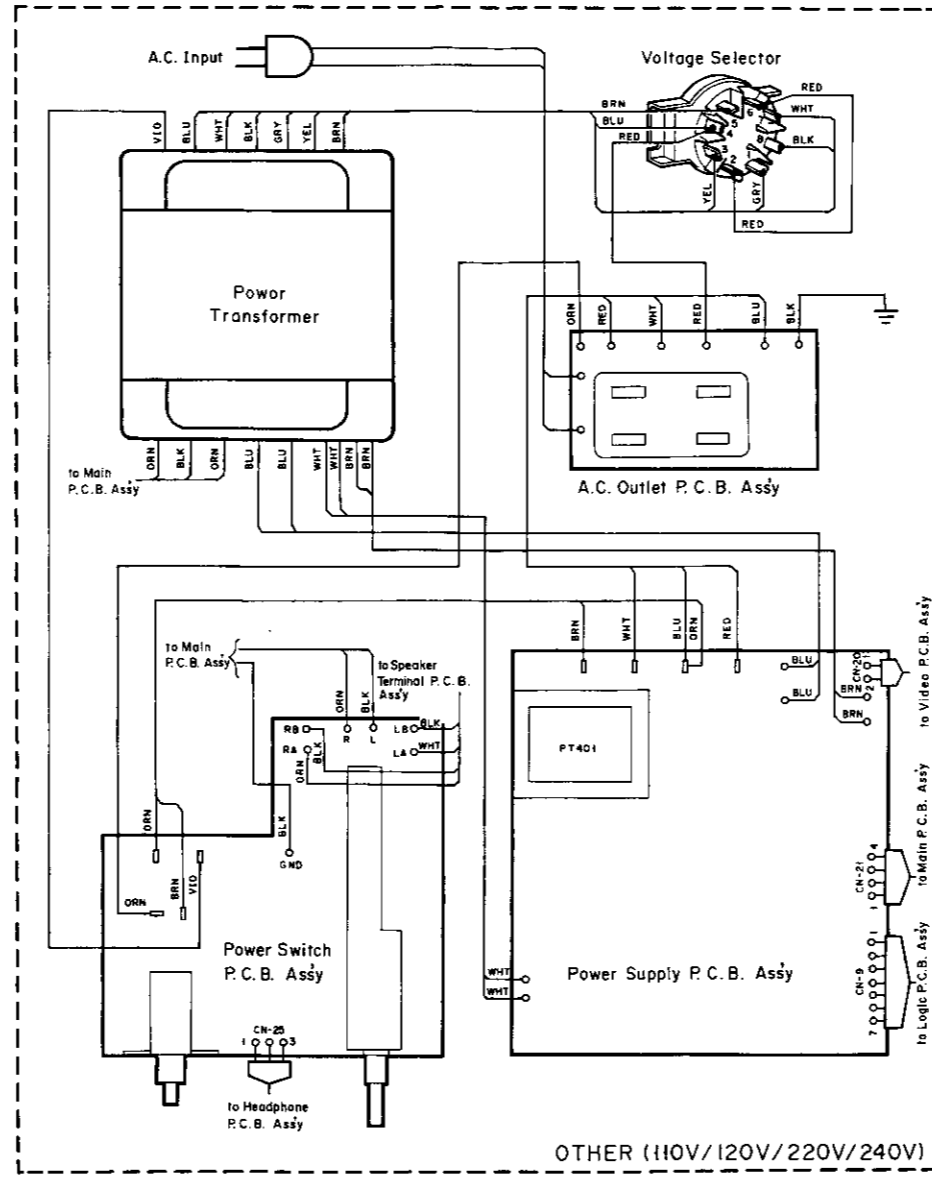
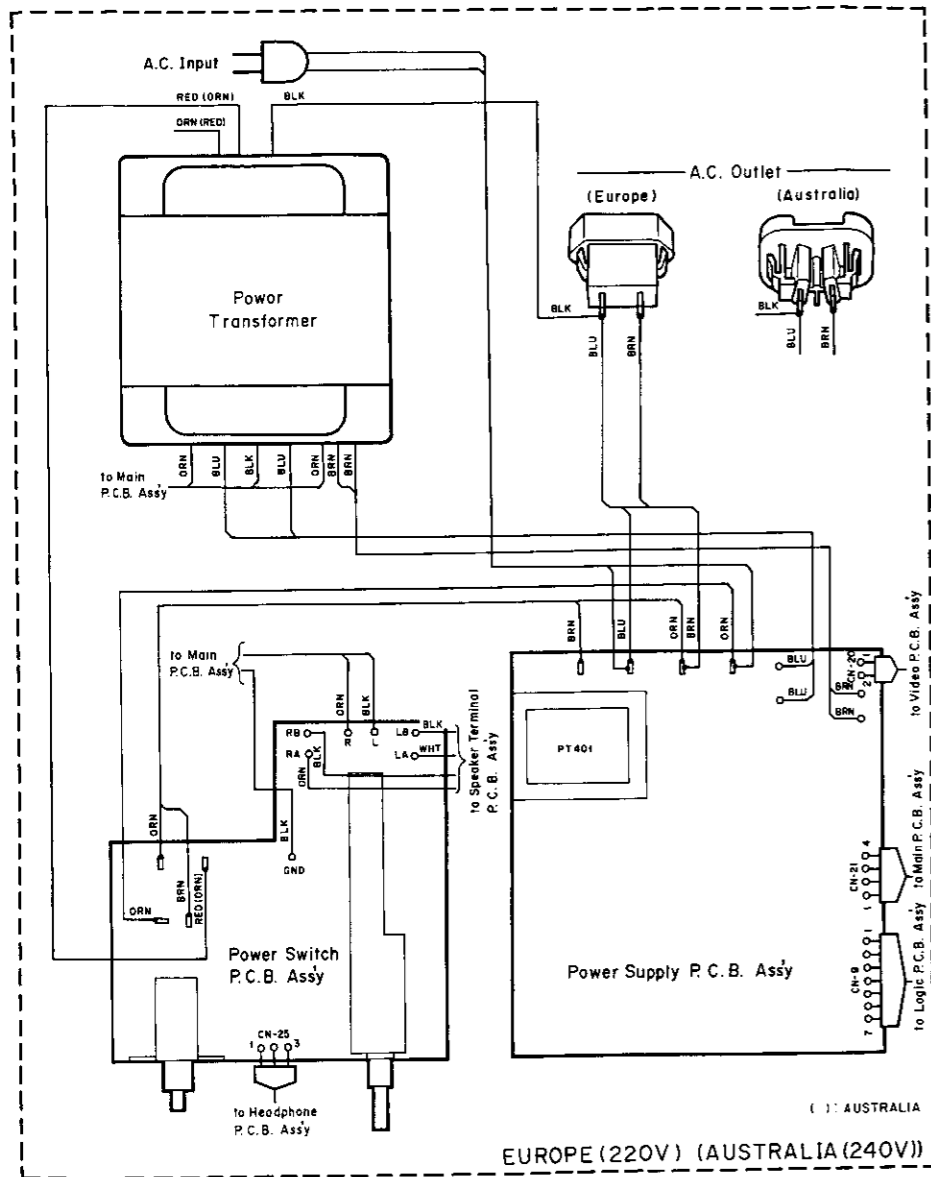

Fig. 7.2.3

Note: U401, Q311, R, Q312, R, Q405 are not included in Heat Sink Assy.

8. WIRING DIAGRAM



- Notes: 1. Table of wire colors
 BRN - Brown BLU - Blue
 RED - Red VIO - Violet
 ORN - Orange GRY - Gray
 YEL - Yellow WHT - White
 GRN - Green BLK - Black
2. Component side view of the P.C.B. is illustrated unless otherwise specified.
3. Wire tube color is shown in ().

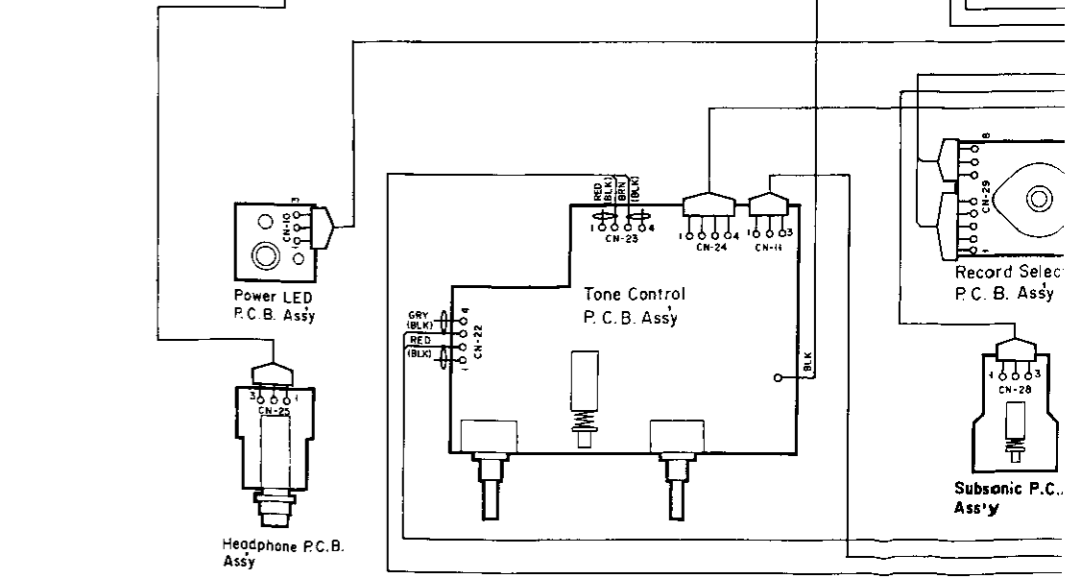

Fig. 8

U.S.A. & CANADA (120V)

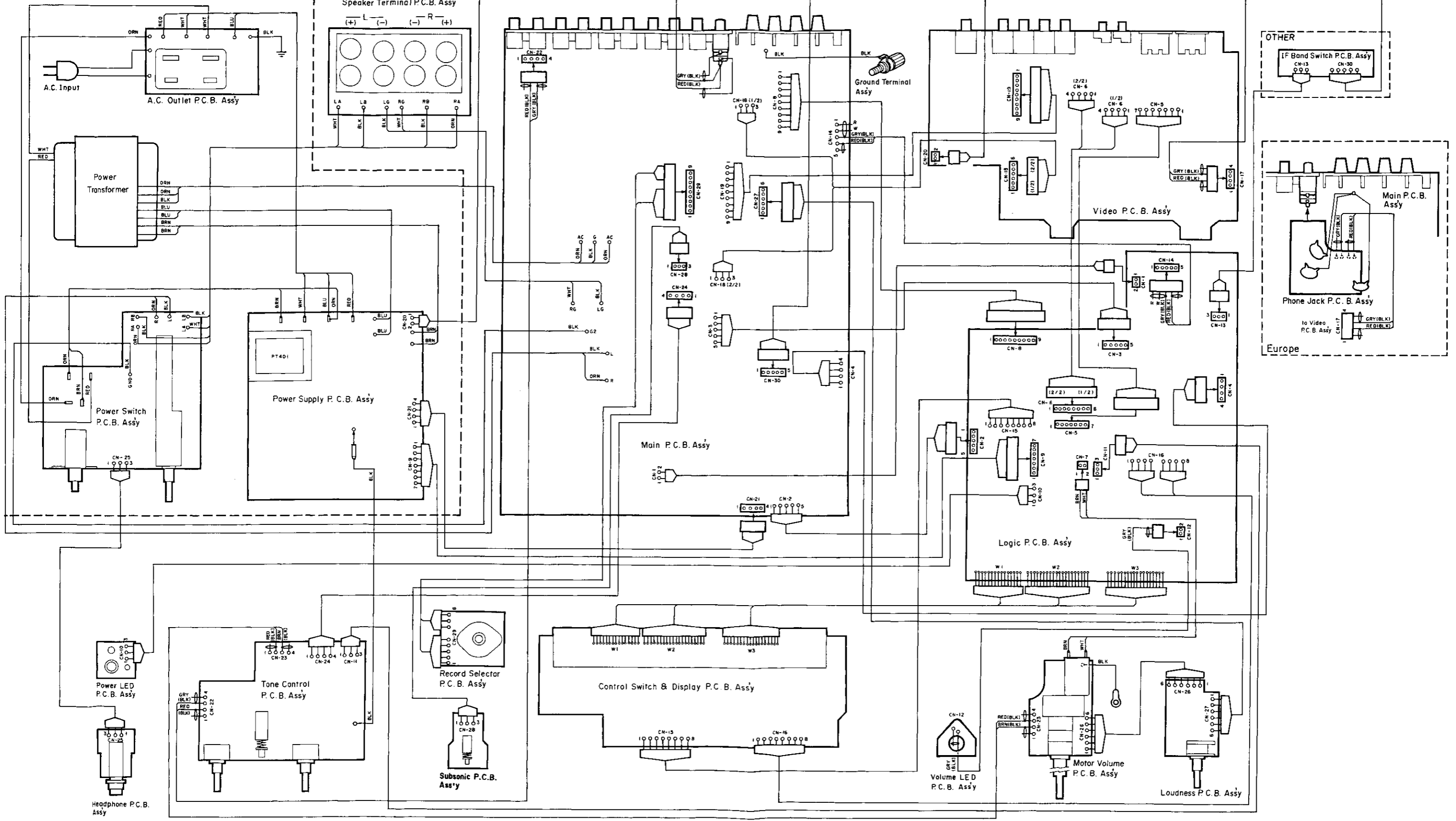

Fig. 8

9. BLOCK DIAGRAMS

9.1. Tuner Section

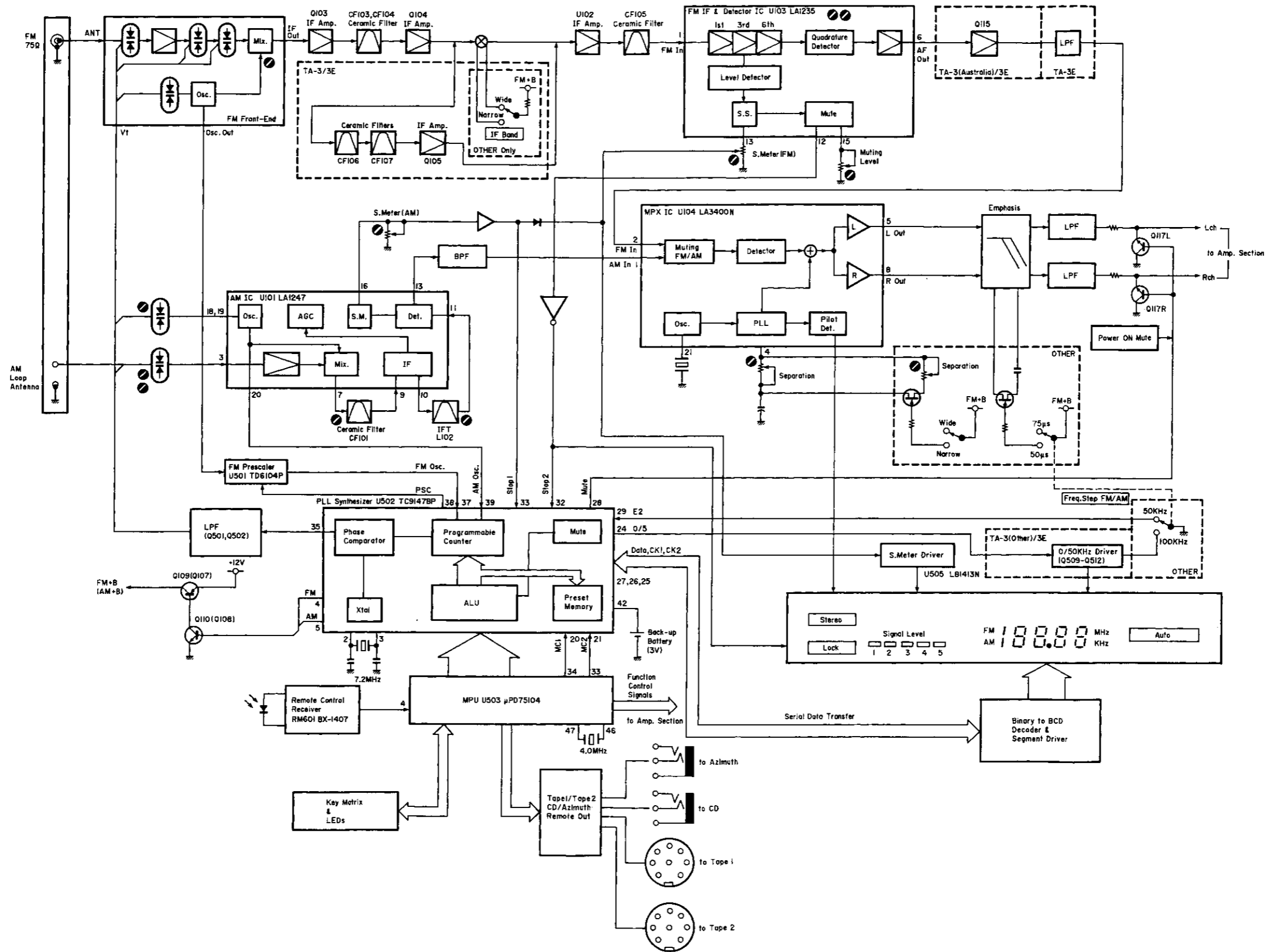

Fig. 9.1

9.2. Amplifier Section

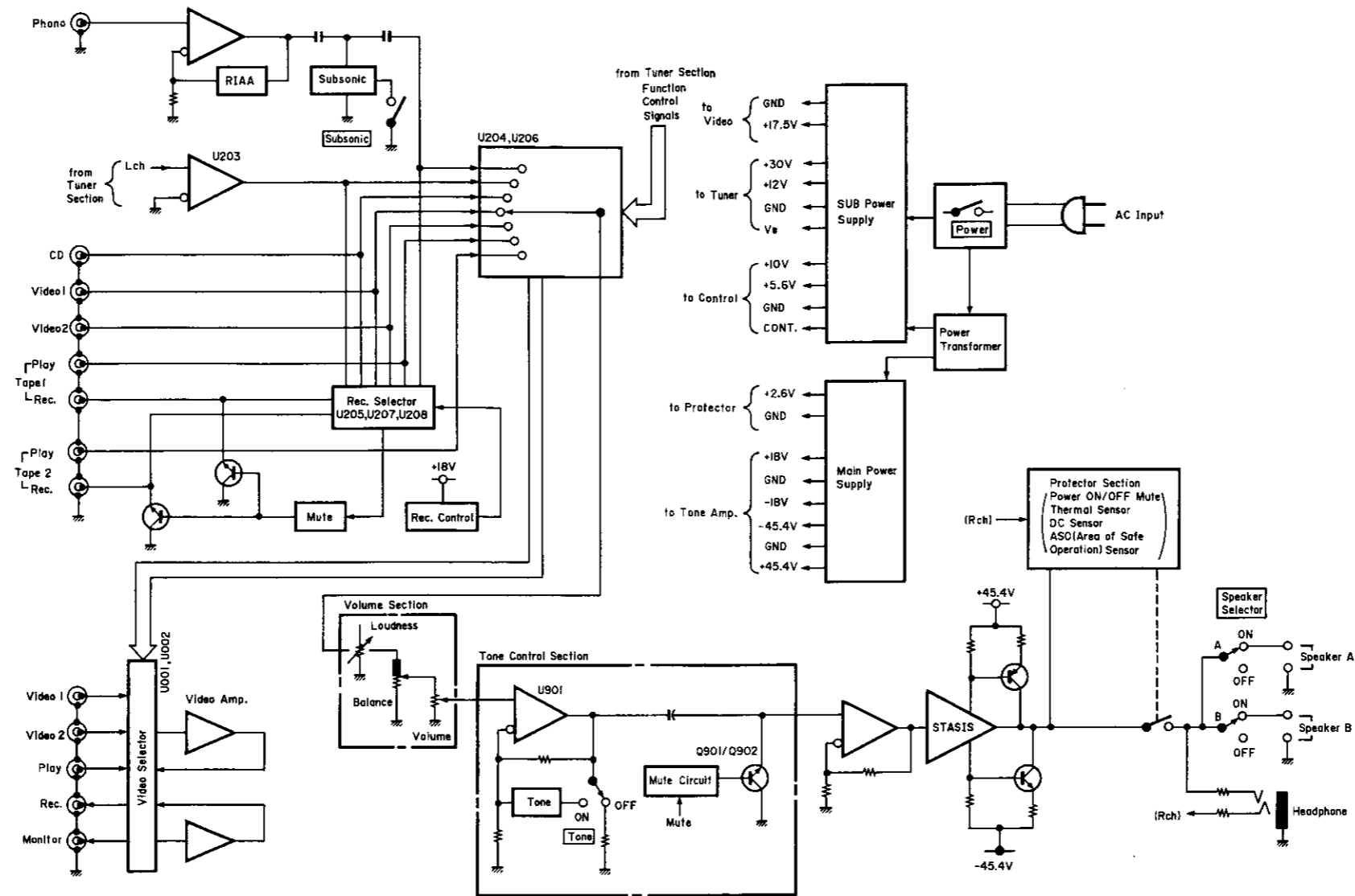

Fig. 9.2

10. SPECIFICATIONS

Power Amplifier Section

Note: Unless noted otherwise, specifications are in accordance with IHF-A-202 measured from any high-level input (CD/VIDEO/TAPE) to the speaker output.

Continuous Average Output Power	75 watts per channel into 8 ohms, both channels driven, 20–20,000 Hz, at no greater than 0.1% THD
Dynamic Output Power	100 watts per channel into 8 ohms 125 watts per channel into 4 ohms
Power Bandwidth	5–50,000 Hz 5–30,000 Hz (TA-3E)
Frequency Response	20–20,000 Hz; +0, –0.5 dB 20–20,000 Hz; +0, –1 dB (TA-3E) 5–75,000 Hz; +0, –3 dB 5–45,000 Hz; +0, –3 dB (TA-3E)
Signal to Noise Ratio (A-WTD, Input Shorted)	Better than 100 dB re Rated Power Better than 83 dB (IHF-A-202)
Total Harmonic Distortion (8 ohms, Rated Power, 20 Hz–20 kHz)	Less than 0.1%
Headphone Rated Output (40 ohms)	175 mW
Output Current Capability	18 A peak per channel

Preamplifier Section

Note: Unless noted otherwise, specifications are in accordance with IHF-A-202. Except for Sensitivity, S/N, Tone Control and Loudness characteristics (which are measured to the speaker outputs), measurements are made from the specified input to Rec. Out.

Sensitivity (for Rated Output)	
Phono MM	2.5 mV
CD/Tape/Video	150 mV
Main In	1.0 V
Sensitivity (for 1-watt output, IHF-A-202)	
Phono MM	0.29 mV
CD/Tape/Video	17 mV
Main In	115 mV
Input Impedance	
Phono MM	47 kohms
CD/Tape/Video	20 kohms
Main In	20 kohms
Maximum Input Level (1 kHz)	
Phono MM	180 mV
Pre Output Level/Impedance	1.0 V/1 kohms
Record Output Level/Impedance	150 mV/1.5 kohms
Total Harmonic Distortion (1 kHz, to Rec. Out, at 1 V)	
Phono MM	Less than 0.008%
RIAA Deviation	
Phono MM	30–20,000 Hz \pm 0.5 dB
Signal to Noise Ratio (to speaker output, IHF-A-202)	
Phono MM	Better than 78 dB Better than 76 dB (TA-3E)
Tone Controls	
Bass	20 Hz, \pm 10 dB
Treble	20 kHz, \pm 10 dB
Variable Loudness (re maximum attenuation: –40 dB at 1 kHz)	20 Hz, +20 dB; 20 kHz, +6 dB
Subsonic Filter (Phono only)	Cutoff Frequency 20 Hz, –12 dB/octave

Tuner Section

(1) TA-3 (Other) (See Note) & TA-3A

Note: Selector switch settings for Other Model

Frequency Step FM/AM: 100 kHz/10 kHz, De-emphasis: 75 μ s, IF Band: Wide

[FM Section]

Note: All RF levels in microvolts given re 300-ohm antenna input.

Modulation: Mono 100%, Stereo Pilot 9%, Stereo Audio Signal 91%.

All measurements made at Rec. Out Jack.

Frequency Range 87.5—108.0 MHz in 100 kHz steps
IHF Usable Sensitivity 11.0 dBf/1.9 μ V
(Mono)
50-dB Quieting Sensitivity
Mono 14.7 dBf/3.0 μ V
Stereo 37.5 dBf/41.1 μ V
Signal to Noise Ratio at 65 dBf
Mono Better than 79 dB
Stereo Better than 74 dB
Muting Threshold 30 dBf/17.3 μ V
Frequency Response 20—15,000 Hz \pm 1 dB
Total Harmonic Distortion (1 kHz)
Mono Less than 0.07%
Stereo Less than 0.07%
Capture Ratio 2.0 dB
Alternate Channel Selectivity . . 55 dB (\pm 400 kHz)
Stereo Separation at 1 kHz Better than 50 dB
Spurious Response Rejection . . . Better than 90 dB
Image Rejection Better than 75 dB
IF Rejection Better than 80 dB
AM Suppression Better than 60 dB

[AM Section]

Note: Modulation — 400 Hz, 30%

Frequency Range 520—1,710 kHz in 10 kHz steps
Sensitivity 53 dB μ /m
Signal to Noise Ratio at 90 Better than 52 dB
dB μ /m
Total Harmonic Distortion Less than 0.5%
at 90 dB μ /m
Selectivity Better than 20 dB (\pm 10 kHz)

(2) TA-3 (Other) (See Note) & TA-3E

Note: Selector switch settings for Other Model

Frequency Step FM/AM: 50 kHz/9 kHz, De-emphasis: 50 μ s, IF Band: Narrow

[FM Section]

Note: All RF levels in microvolts given re 300-ohm antenna input.

Modulation: Mono 60%, Stereo Pilot 9%, Stereo Audio Signal 51%.

All measurements made at Rec. Out Jack.

Frequency Range	87.50—108.00 MHz in 50 kHz steps
IHF Usable Sensitivity (Mono)	11.0 dBf/1.9 μ V
50-dB Quieting Sensitivity	
Mono	23.0 dBf/7.7 μ V
Stereo	44.0 dBf/86.8 μ V
Signal to Noise Ratio at 65 dBf	
Mono	Better than 72 dB (TA-3E)/75 dB (TA-3 (Other))
Stereo	Better than 67 dB
Muting Threshold	30 dBf/17.3 μ V
Frequency Response	20—15,000 Hz \pm 1 dB
Total Harmonic Distortion (1 kHz)	
Mono	Less than 0.20%
Stereo	Less than 0.25%
Capture Ratio	2.0 dB
Alternate Channel Selectivity	70 dB (\pm 300 kHz)
Stereo Separation at 1 kHz	Better than 40 dB
Spurious Response Rejection	Better than 90 dB
Image Rejection	Better than 75 dB
IF Rejection	Better than 80 dB
AM Suppression	Better than 60 dB

[AM Section]

Note: Modulation — 400 Hz, 30%

Frequency Range	522—1,611 kHz in 9 kHz steps
Sensitivity	53 dB μ /m
Signal to Noise Ratio at 90	Better than 52 dB
dB μ /m	
Total Harmonic Distortion	Less than 0.5%
at 90 dB μ /m	
Selectivity	Better than 20 dB (\pm 9 kHz)

General

Power Source	120, 220, 240 or 110/120/220/240 V AC, 50/60 Hz (According to country of sale)
Power Consumption	350 watts max.
Convenience Outlets	Switched: 2 (For TA-3 (Other) & TA-3A), Switched: 1 (TA-3E)
Dimensions	430 (W) x 100 (H) x 370 (D) mm 16-15/16 (W) x 3-15/16 (H) x 14-9/16 (D) inches
Approximate Weight	11.0 kg, 24 lbs. 4 oz.

Remote Control Unit (RM-3TA)

Principle	Infrared Pulse System
Power Supply	3 V DC (1.5 V x 2)
Dimensions	64 (W) x 18 (H) x 176 (D) mm 2-1/2 (W) x 11/16 (H) x 6-15/16 (D) inches
Approximate Weight	140 g, 5 oz. (including batteries)

- Specifications and design are subject to change for further improvement without notice.
- STASIS manufactured under license from Threshold Corporation.
- STASIS is a trademark of Threshold Corporation.

Service Information



Model TA-3/3A/3E/30 (High Definition Tuner Amplifer)
 Serial No. from D10951896 -

No. OOD-M-0337 (1/1)
 Date 8 February 1990

Subject Change of Transistors

1. General

1.1. Purpose

To obtain greater power margin (collector dissipation), Q208 and Q209 on the Main P.C.B. Ass'y have been changed.

If you receive a complaint about transistor damage from your customer, we recommend you to change the damaged transistor to a new one having greater power margin.

1.2. Modification

Refer to Fig. 1.

Q208 and Q209 on the Main P.C.B. Ass'y have been changed as follows:

Ref. No.	Current		New		Q'ty
	Part No.	Description	Part No.	Description	
Q208	OB06013A	TR 2SA733	OB06372A	TR 2SA953	1
Q209	OB06100A	TR 2SC945	OB06322A	TR 2SC2002	1

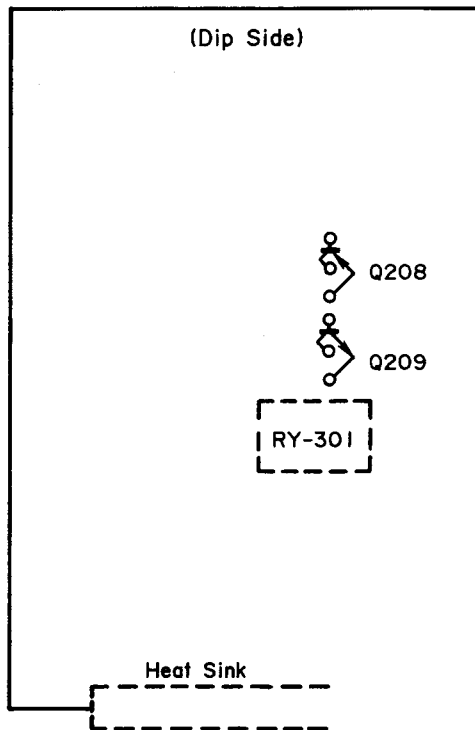

Note: See Fig. 6.18 (page 21) in the Service Manual.

Fig. 1 (Main P.C.B. Ass'y)

