



Service Manual

Nakamichi

TA-1

TA-1A

TA-1E

High Definition Tuner Amplifier

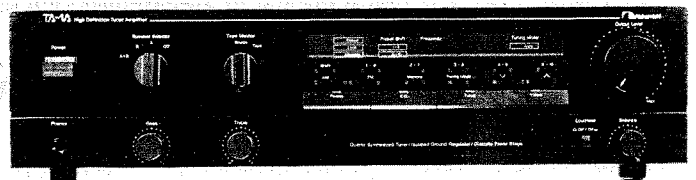

CONTENTS

1.	General	1
2.	Removal Procedures	3
2. 1.	Top Cover Ass'y and Bottom Cover Ass'y	3
2. 2.	Front Panel	3
2. 3.	Power Switch P.C.B. Ass'y	3
2. 4.	Volume P.C.B. Ass'y and Balance & Loudness P.C.B. Ass'y	4
2. 5.	Front Chassis Ass'y	4
2. 6.	Synthesizer P.C.B. Ass'y and Control Switch & Display P.C.B. Ass'y	4
3.	Parts Location for Electrical Adjustment	5
4.	Electrical Adjustments	5
4. 1.	Power Amplifier Section	5
4. 2.	Tuner Section	6
4.2.1.	FM Tuner Section	6
4.2.2.	AM Tuner Section	8
5.	Mechanism Ass'y and Parts List	9
5. 1.	Synthesis	9
5. 2.	Chassis Ass'y (A01)	10
5. 3.	Heat Sink Ass'y (B01)	11
5. 4.	Front Chassis Ass'y (B02)	11
6.	Mounting Diagrams and Parts List	12
6. 1.	AC Outlet P.C.B. Ass'y	12
6. 2.	Power Switch P.C.B. Ass'y	12
6. 3.	Speaker Terminal P.C.B. Ass'y	12
6. 4.	Headphone P.C.B. Ass'y	13
6. 5.	Monitor Switch P.C.B. Ass'y	13
6. 6.	Volume P.C.B. Ass'y	13
6. 7.	Balance & Loudness P.C.B. Ass'y	13
6. 8.	Tone Control P.C.B. Ass'y	13
6. 9.	Control Switch & Display P.C.B. Ass'y	14
6. 10.	Synthesizer P.C.B. Ass'y	14
6. 11.	Main P.C.B. Ass'y	15
7.	Schematic Diagrams	16
7. 1.	IC Block Diagrams	16
7. 2.	Schematic Diagrams	17
7.2.1.	Tuner Section	17
7.2.2.	Amplifier Section	18
8.	Wiring Diagram	19
9.	Block Diagrams	20
9. 1.	Tuner Section	20
9. 2.	Amplifier Section	20
10.	Specifications	21

1. GENERAL

1.1. CAUTIONS/WARNINGS

(1) Product Safety Notice

Parts marked with the symbol  in the schematic diagram have critical characteristics. Use ONLY replacement parts recommended by the manufacturer.

It is recommended that the unit be operated from a suitable DC supply or batteries during initial check-out procedures.

(2) Leakage Current Check/Resistance Check

Before returning the unit to the customer, make sure you make either (1) a leakage current check or (2) a line to chassis resistance check. If the leakage current exceeds 0.5 milliamp, or if the resistance from chassis to either side of the power cord is less than 240 k ohms, the unit is defective.

WARNING — DO NOT return the unit to the customer until the problem is located and corrected.

1.2. Voltage Selector

Voltage selector is installed on the rear panel for Other version of the TA-1. This voltage selector can select 110, 120, 220, or 240 V at customer's disposal.

1.3. Package Ass'y

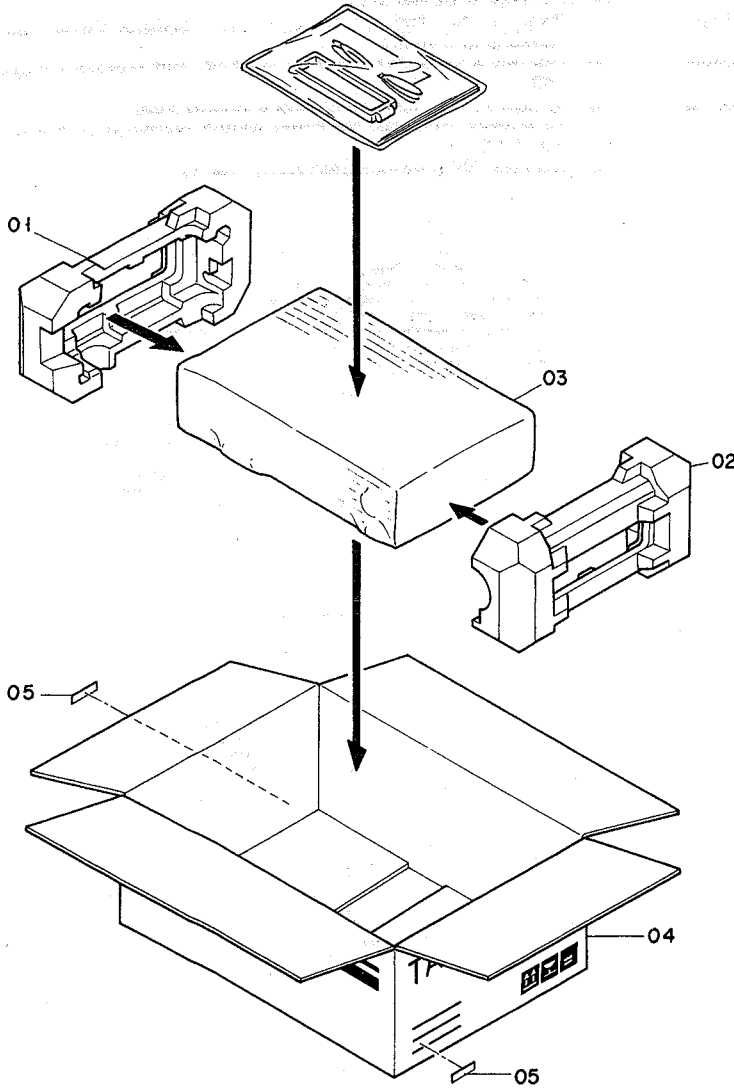

Fig. 1.1

1.4. Accessory Ass'y

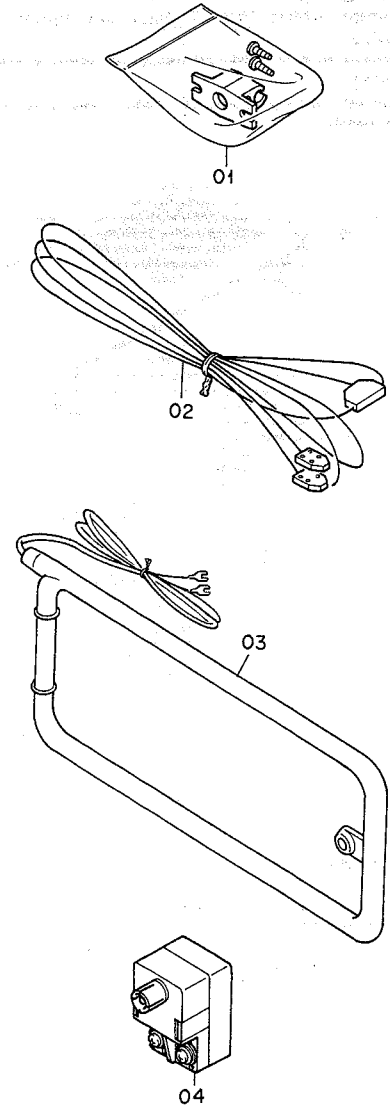

Fig. 1.2

Schematic Ref. No.	Part No.	Description	Q'ty	Schematic Ref. No.	Part No.	Description	Q'ty
		Package Ass'y				Accessory Ass'y	
01	0F04087E	Packing L (TA-1 & TA-1E)	1	01	0B90319A	Loop Antenna Holder	1
	0F04178A	Packing L (TA-1A)	1		0E03496A	Screw 3.1x10 ⊕ (Black Chromate)	2
02	0F04088E	Packing R (TA-1 & TA-1E)	1	02	0B90320A	Feeder Antenna	1
	0F04179A	Packing R (TA-1A)	1	03	0B90318A	AM Loop Antenna	1
03	0F04107A	Soft Sheet (TA-1 & TA-1E)	1	04	0B90208A	Antenna Adapter F (TA-1E)	1
	0F04108A	Poly-Sheet (TA-1A)	1		0D03092B	Poly Bag for Accessory (TA-1 & TA-1E)	1
04	0F04185A	Carton Box (TA-1)	1		0D04873A	Supplement (TA-1 (Other))	1
	0F04170A	Carton Box (TA-1A)	1		0D04811A	Poly Bag for Accessory (TA-1A)	1
	0F04186A	Carton Box (TA-1E)	1		0D04212A	Poly Bag for Accessory (TA-1 & TA-1E)	1
05	0M05215A	Serial No. Label (TA-1 & TA-1E)	2		0D04766B	General Catalog (TA-1A)	1
	0M05197A	Serial No. Label (TA-1A)	2		0D04877A	Tape Catalog (TA-1A)	1
	0M03457A	Voltage Label 240V (TA-1 (Australia))	2		0D04836C	Warranty Card (TA-1A)	1
					0D04810A	Important Notice	1
					0D04871B	Owner's Manual (English/German/French)	1

2. REMOVAL PROCEDURES

2.1. Top Cover Ass'y and Bottom Cover Ass'y

Refer to Fig. 2.1.

- (1) Loosen screws F01 (5 pcs.) and remove F02 (Top Cover Ass'y).
- (2) Loosen screws F03 (10 pcs.) and remove F04 (Bottom Cover Ass'y).
- (3) Loosen screws F05 (2 pcs.) and remove legs (F06) as required.

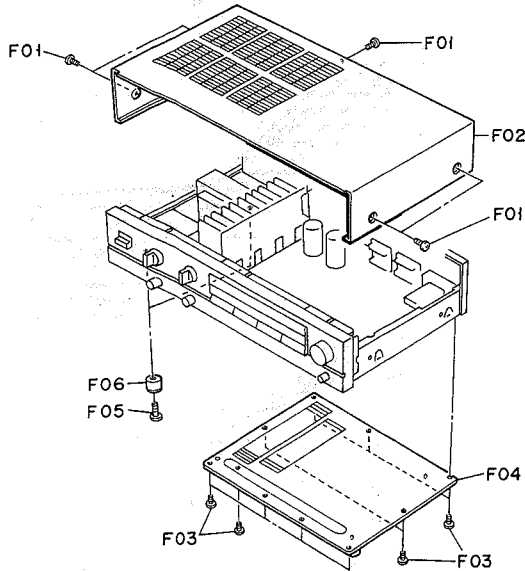

Fig. 2.1

2.2. Front Panel

Refer to Fig 2.2.

- (1) Remove the Top Cover Ass'y and Bottom Cover Ass'y referring to item 2.1.
- (2) Loosen screws F01 (3 pcs.) and F02 (2 pcs.), and remove F03 (Front Panel).

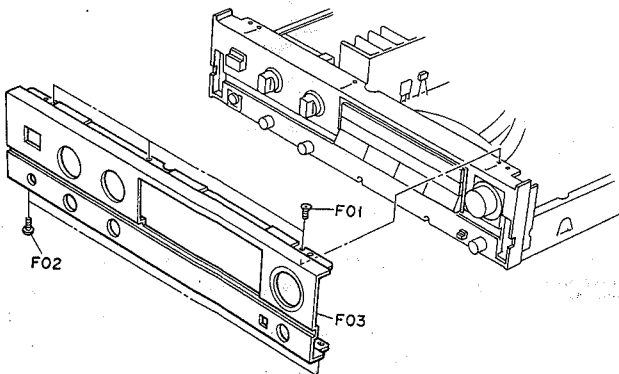

Fig. 2.2

2.3. Power Switch P.C.B. Ass'y

Refer to Figs. 2.3.1 and 2.3.2.

- (1) Remove the Top Cover Ass'y and Bottom Cover Ass'y referring to item 2.1.
- (2) Pull out a knob F01, loosen a nut F02, and remove a washer F03.
- (3) Loosen a screw F04 and remove a button F05. To remove F05, push the Power Switch rearward as shown in Fig. 2.3.2.
- (4) Remove F06 (Power Switch P.C.B. Ass'y).

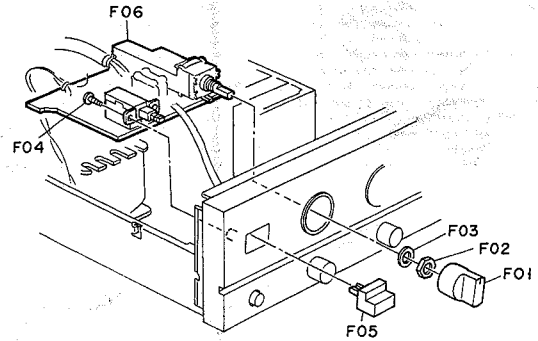

Fig. 2.3.1

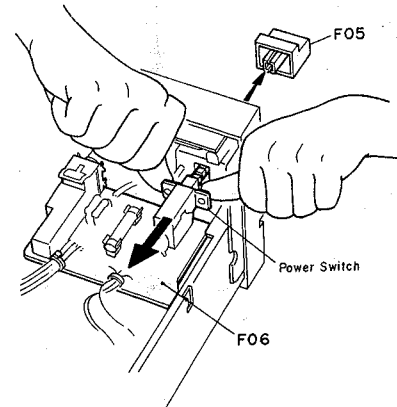

Fig. 2.3.2

2.4. Volume P.C.B. Ass'y and Balance & Loudness P.C.B. Ass'y
Refer to Figs. 2.4.1 and 2.4.2.

- (1) Remove the Top Cover Ass'y and Bottom Cover Ass'y referring to item 2.1.
- (2) Pull out a knob F01, loosen a nut F02, remove a washer F03, and disassemble F04 (Volume P.C.B. Ass'y).
- (3) Pull out a knob F05, loosen a nut F06, and remove a washer F07.
- (4) Unhook a claw F08 and remove F09 (Balance & Loudness P.C.B. Ass'y). Refer to Fig. 2.4.2.

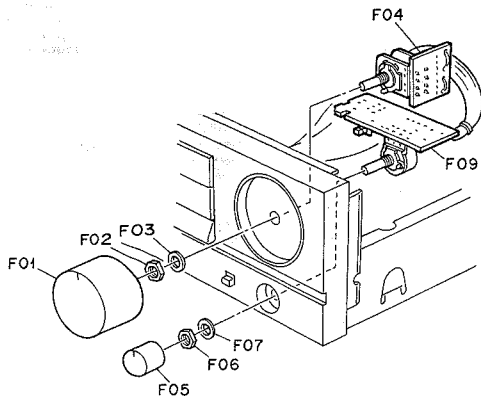

Fig. 2.4.1

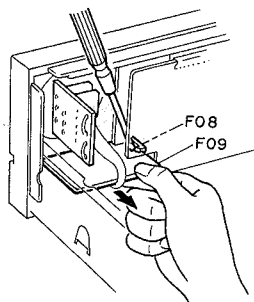

Fig. 2.4.2

2.5. Front Chassis Ass'y

Refer to Figs. 2.5.1 and 2.5.2.

- (1) Remove the Front Panel referring to item 2.2.
- (2) Remove the Power Switch P.C.B. Ass'y referring to item 2.3.
- (3) Loosen screws F01 (7 pcs.).
- (4) Lift F02 (Front Chassis Ass'y) and pull it frontward. Refer to Fig. 2.5.2.

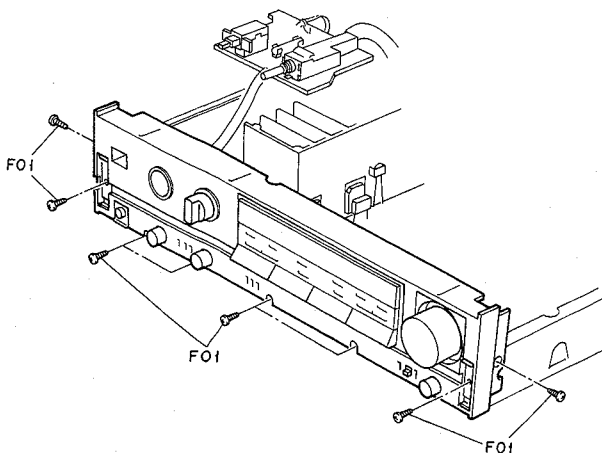

Fig. 2.5.1

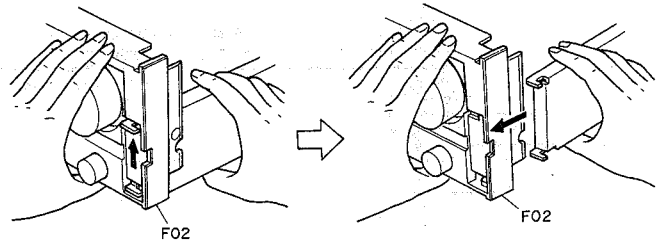

Fig. 2.5.2

2.6. Synthesizer P.C.B. Ass'y and Control Switch & Display P.C.B. Ass'y

Refer to Figs. 2.6.1 and 2.6.2.

- (1) Remove the Front Chassis Ass'y referring to item 2.5.
- (2) Loosen screws F01 (2 pcs.) and lift F02 (Synthesizer P.C.B. Ass'y). Cut insu-locks (cable ties) as required.
- (3) Loosen screws F03 (2 pcs.) and remove F04 (Front P.C.B. Holder).
- (4) Loosen screws F05 (5 pcs.) and remove F06 (Control Switch & Display P.C.B. Ass'y).

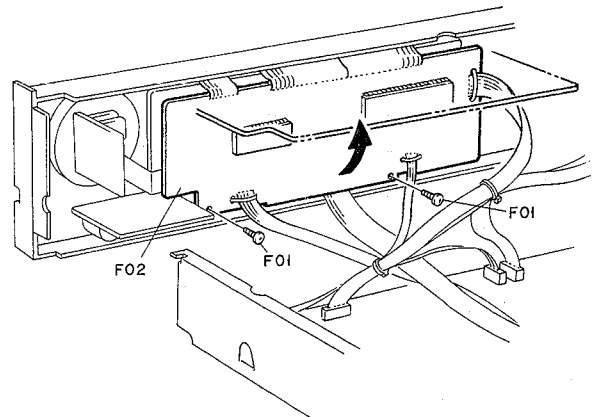

Fig. 2.6.1

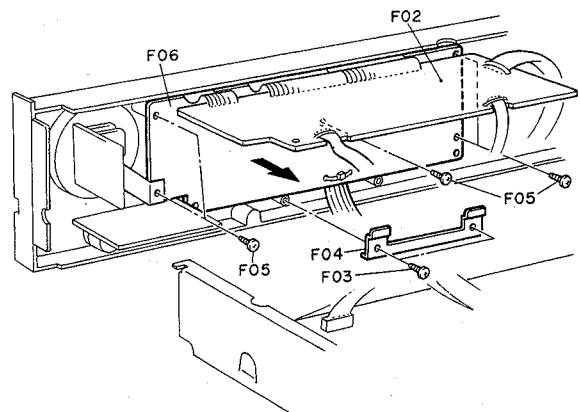

Fig. 2.6.2

3. PARTS LOCATION FOR ELECTRICAL ADJUSTMENT

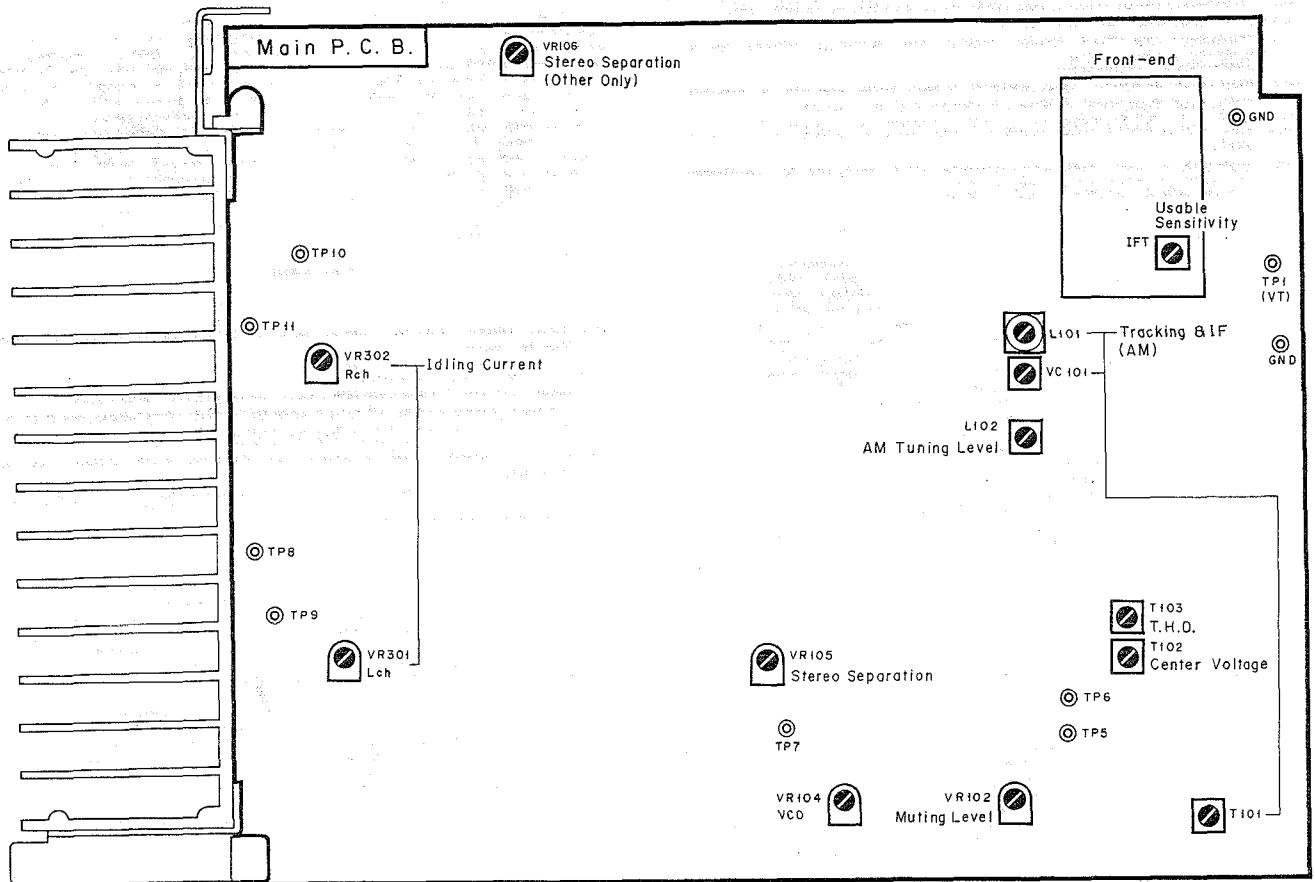

Fig. 3

4. ELECTRICAL ADJUSTMENTS

4.1. Power Amplifier Section

STEP	ITEM	SIGNAL SOURCE	OUTPUT CONNECTION	MODE	ADJUSTMENT	REMARKS
1	Idling Current	None	DC Voltmeter between TP8,9 (L) and TP10, 11 (R) on Main P.C.B.	Input Selector - CD Output Level - Min. Speaker Selector - OFF	Main P.C.B. VR301 VR302	<ol style="list-style-type: none"> 1. Insert shorting plugs into the CD Input Jacks. 2. Turn ON the power and allow 3 minutes before adjustment. (Top Cover must be installed before adjustment). 3. Adjust VR301 (VR302) to obtain $4 \text{ mV} \pm 1 \text{ mV}$ on the DC voltmeter.

4.2. Tuner Section

Note: Adjustment should be made in a shielded room in principle.

4.2.1. FM Tuner Section

STEP	ITEM	OUTPUT CONNECTION	MODE	ADJUSTMENT	REMARKS
1	Preliminary Step	See Fig. 4.1	Tuner Amplifier Input Selector - Tuner Band Selector - FM Tape Monitor - Source Signal Generator Freq. - 98 MHz RF Level - 65 dBf Modulation - See REMARKS		1. Set the Tuner Amplifier as indicated in the MODE. 2. Adjustment and confirmation should be made after tuning in to the set carrier frequency of the Signal Generator. Note: Contents of modulation 1. For U.S.A., Canada & Other (Wide) o Stereo Audio: 1 kHz, 91% Pilot: 19 kHz, 9% o Mono Audio: 1 kHz, 100% 2. For Australia, Europe & Other (Narrow) o Stereo Audio: 1 kHz, 51% Pilot: 19 kHz, 9% o Mono Audio: 1 kHz, 60%
2	Usable Sensitivity Adjustment	Distortion Meter to Tape Record Output Jacks	Tuner Amplifier Same as above Signal Generator Freq. - 98 MHz RF Level - 13.5 dBf Modulation - Mono	Main P.C.B. Front-end IFT	1. Set the Tuner Amplifier to Manual mode by pressing the Tuning Mode button. 2. Adjust the IFT to obtain minimum distortion (total harmonic distortion (THD): 3% or less). 3. Set the frequency of the Signal Generator to 90 MHz/106 MHz and check that the THD is 3% or less.
3	Center Voltage and THD Adjustment	DC Voltmeter between TP5 & TP6 on Main P.C.B. and Distortion Meter to Tape Record Output Jacks	Tuner Amplifier Same as above Signal Generator Freq. - 98 MHz RF Level - 65 dBf Modulation - Mono	Main P.C.B. T102 T103	1. Set the Tuner Amplifier to Manual mode. 2. Adjust T102 so that the reading on the DC voltmeter is 0 V \pm 20 mV. 3. Adjust T103 to obtain minimum distortion (THD: 0.15% or less). Repeat 2 and 3, if necessary.
4	Muting Level Adjustment	Oscilloscope to Tape Record Output Jacks	Tuner Amplifier Same as above Signal Generator Freq. - 98 MHz RF Level - 30 dBf Modulation - Stereo	Main P.C.B. VR102	1. Set the Tuner Amplifier to Auto mode. 2. Rotate VR102 fully counterclockwise. Then, return it clockwise gradually until a waveform appears on the oscilloscope. 3. Decrease the RF level of the Signal Generator until the waveform on the oscilloscope disappears. Then increase the RF level gradually until a waveform appears again. At this point, check that the RF level of the Signal Generator is 30 dBf \pm 3 dB.

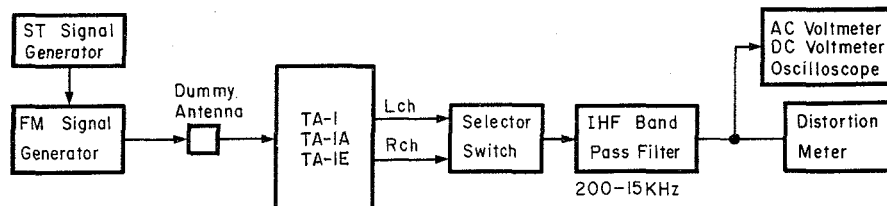
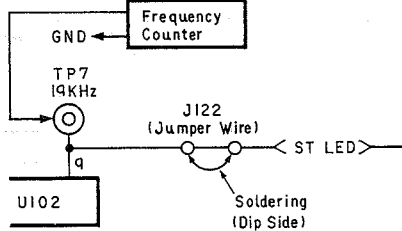

Fig. 4.1 FM Measuring Connection

STEP	ITEM	OUTPUT CONNECTION	MODE	ADJUSTMENT	REMARKS
5	VCO Adjustment	Frequency Counter to TP7 and GND on Main P.C.B.	Tuner Amplifier Same as above Signal Generator Freq. - 98 MHz RF Level - 0 dBf Modulation - Stereo	Main P.C.B. VR104	<p>1. Remove the Jumper Wire (J122). Note: See the dip side of the P.C.B. and make sure that both lands of J122 are not shortcircuited by soldering. If shortcircuited, remove the soldering.</p>  <p>2. Cut RF signal applied to the Tuner Amplifier. 3. Adjust VR104 to obtain 19 kHz \pm50 Hz on the frequency counter. 4. After adjustment, mount the Jumper Wire (J122).</p>
6	Stereo Separation Adjustment	AC Voltmeter to Tape Record Output Jacks	Tuner Amplifier Same as above Signal Generator Freq. - 98 MHz RF Level - 65 dBf Modulation - L or R only	Main P.C.B. VR105 VR106 (Other Only)	<p>For U.S.A., Canada, Europe & Australia versions:</p> <ol style="list-style-type: none"> Set the Tuner Amplifier to Auto mode. Apply modulation to only L channel. Adjust VR105 to obtain minimum reading on the AC voltmeter at the R channel output jack. Apply modulation to only R channel. Check that the reading on the AC voltmeter at the L channel output jack is within ± 1 dB with respect to the reading in 3. If not, repeat 2 through 4. <p>For Other version:</p> <ol style="list-style-type: none"> Set the switches on the rear panel as follows: Freq. Step FM/AM - 100 kHz/10 kHz IF Band - Wide Adjust VR105 by applying the same procedures as mentioned above. Set the switches on the rear panel as follows: Freq. step FM/AM - 50 kHz/9 kHz IF Band - Narrow Apply the same procedures as mentioned above. Adjust VR106 instead of VR105.

4.2.2. AM Tuner Section

Note: Frequencies for Australia, Europe & Other (Narrow) are indicated in parentheses.

STEP	ITEM	OUTPUT CONNECTION	MODE	ADJUSTMENT	REMARKS
1	Tuning Level Adjustment	DC Voltmeter between TP1 (VT) and GND on Main P.C.B.	Tuner Amplifier Input Selector - Tuner Band Selector - AM Tape Monitor - Source Signal Generator Not used.	Main P.C.B. L102	<ol style="list-style-type: none"> 1. With no input signal from the Signal Generator, set the frequency of the TA-1/1A/1E to 520 (522) kHz. 2. Adjust L102 to obtain 1.0 V on the DC voltmeter. 3. Set the frequency of the TA-1/1A/1E to 1710 (1611) kHz and check whether the reading on the DC voltmeter is approx. 8.7 V. 4. Vary the frequency of the TA-1/1A/1E from 520 (522) kHz to 1710 (1611) kHz and check whether the reading on the DC voltmeter varies from 1.0 V to approx. 8.7 V.
2	Tracking and IF Adjustment	AC Voltmeter to Tape Record Output Jacks	Tuner Amplifier Same as above Signal Generator Freq. - 600 (603) kHz/ 1400 (1404) kHz RF Level - 98 dB μ /m Modulation - 400 Hz 30%	Main P.C.B. L101 T101 VC101	<ol style="list-style-type: none"> 1. Set the measurement instruments as shown in Fig. 4.2. Set the distance between the AM Loop Antenna of the TA-1/1A/1E and a test loop to 60 cm. To obtain 90 dBμ/m at the AM Loop Antenna, set the RF level output of the AM Signal Generator to 116 dBμ/m as loss is 26 dBμ/m in this setting. 2. Set the frequency of the Signal Generator to 600 (603) kHz and make tuning. 3. Adjust L101 to obtain maximum reading on the AC voltmeter. 4. Adjust T101 to obtain maximum reading on the AC voltmeter. 5. Set the frequency to 1400 (1404) kHz and make tuning. 6. Adjust VC101 to obtain maximum reading on the AC voltmeter. 7. Repeat 2 through 6 once.

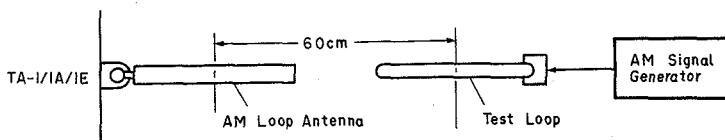

Fig. 4.2

5. MECHANISM ASS'Y AND PARTS LIST

5.1. Synthesis

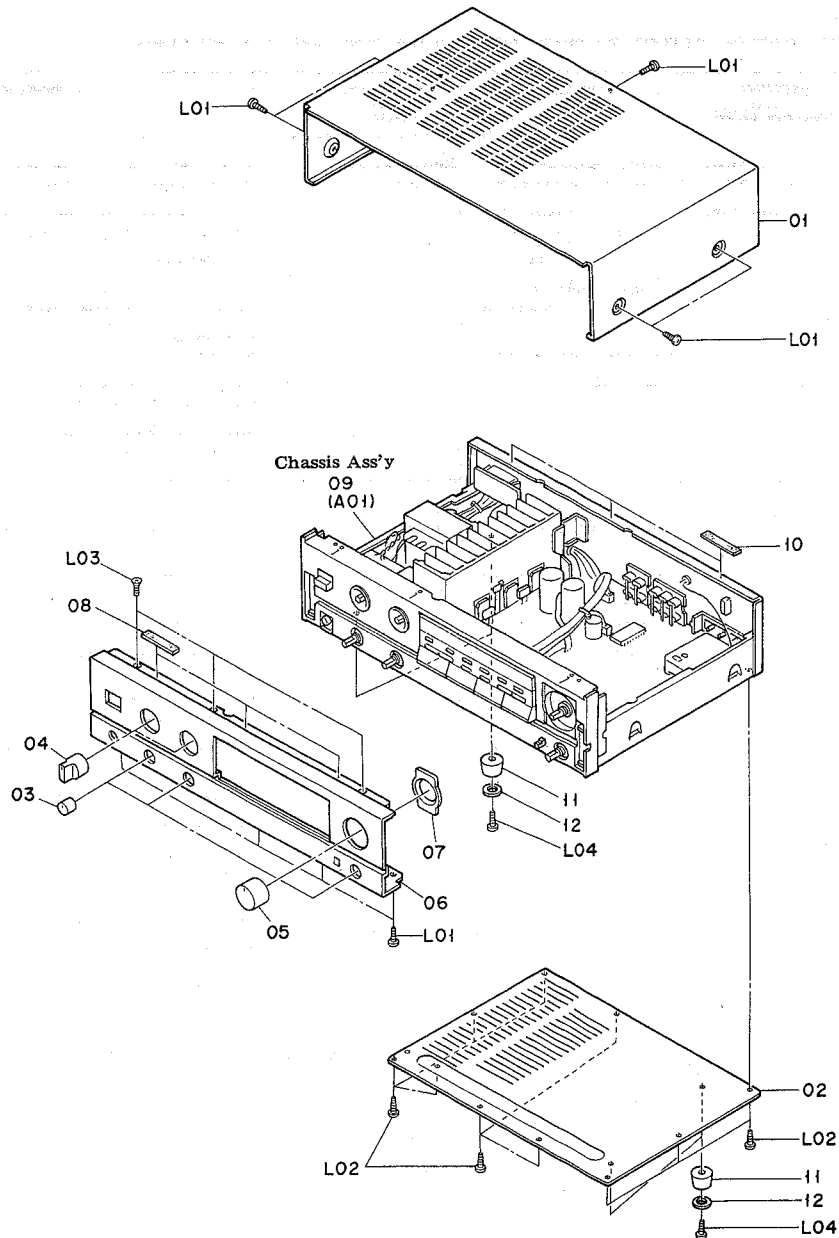

Fig. 5.1

Schematic Ref. No.	Part No.	Description	Q'ty	Schematic Ref. No.	Part No.	Description	Q'ty
5.1. Synthesis				L01	OE03433A	BT3x6 ⊕ Binding Projected (Black Chromate)	9
Synthesis				L02	OE00857A	BT3x6 ⊕ Binding	10
01	OH05315A	Top Cover	1	L03	OE03054A	BT3x8 ⊕ Countersunk	3
02	OJ05606A	Bottom Cover	1	L04	OE00888A	BT3x12 ⊕ Binding	4
03	OH05318A	Tone Knob	3	—	OM04377B	Caution Label (TA-1A)	1
04	OH05321A	Selector Knob	2	—	OM04381A	EP Approval Label (TA-1E)	1
05	HA05444A	Volume Knob Ass'y	1	—	OM05068A	LA Label (TA-1A)	1
06	OH05378A	Front Panel (TA-1)	1	—	OM05148A	Production Date Label (TA-1A)	1
—	OH05312A	Front Panel (TA-1A)	1	—	OM05172A	Pass Label (TA-1A)	1
—	OH05377A	Front Panel (TA-1E)	1	—	OM05197A	Serial No. Label (TA-1A)	1
07	OH05313A	Escutcheon Ring	1	—	OM05215A	Serial No. Label (TA-1 & TA-1E)	1
08	OJ05453A	Top Cover Cushion	3	—	OM05219A	DBP Approval Label (TA-1E)	1
09	—	Chassis Ass'y	1	—	OM04811A	Voltage Caution Sheet (TA-1 (Other))	1
10	OJ05407A	Top Cover Sheet R	3	—	OM04812A	Voltage Caution Label (TA-1 (Other))	1
11	OJ05420A	Leg N	4				
12	OJ05461A	Leg Felt N	4				

5.2. Chassis Ass'y (A01)

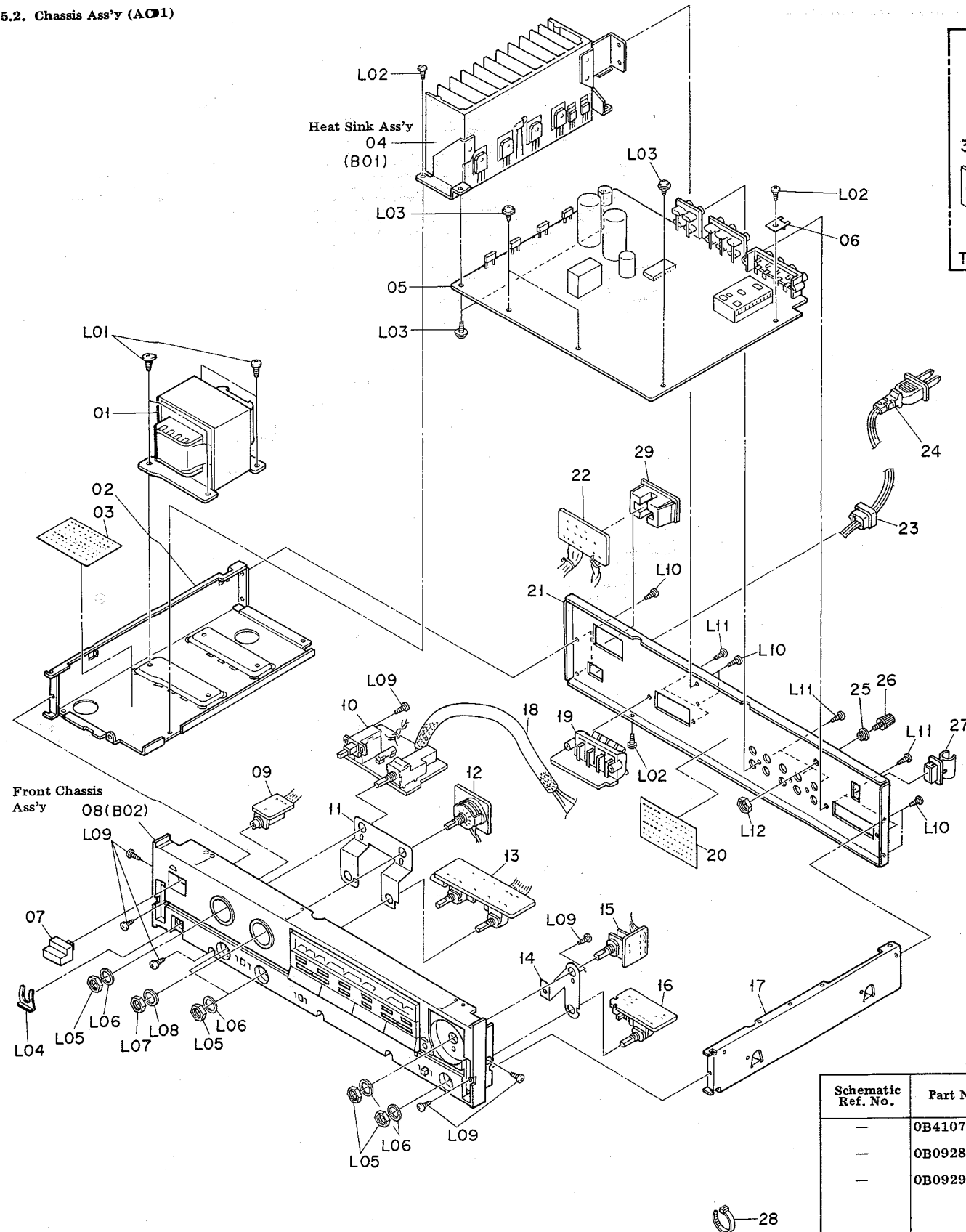

Fig. 5.2

Schematic Ref. No.	Part No.	Description	Qty
—	OB41071A	Ceramic Capacitor 100P 50V J (TA-1E)	2
—	OB09288A	Ceramic Capacitor 1000P 50V K (TA-1E)	3
—	OB09290A	Ceramic Capacitor 0.01μF 50V Z (TA-1E)	3

Schematic Ref. No.	Part No.	Description	Qty
5.2. Chassis Ass'y (A01)			
A01	—	Chassis Ass'y	1
01	OB50120A	Power Transformer (TA-1 (Australia) & TA-1E)	1
	OB50122A	Power Transformer (TA-1 (Other))	1
	OB50113A	Power Transformer (TA-1A (U.S.A.))	1
	OB50125A	Power Transformer (TA-1A (Canada))	1
02	OJ05604A	Side Chassis L	1
03	OM05196A	Fuse Label T3A 250V (TA-1A)	1
04	BA07309A	Heat Sink Ass'y	1
05	BA07312A	Main P.C.B. Ass'y (TA-1 (Australia))	1
	BA07310A	Main P.C.B. Ass'y (TA-1 (Other))	1
	BA07269A	Main P.C.B. Ass'y (TA-1A)	1
	BA07311A	Main P.C.B. Ass'y (TA-1E)	1
06	OJ05670A	Earth Plate	1
07	OH05325A	Power Button	1
08	HA05445A	Front Chassis Ass'y (TA-1 & TA-1A)	1
	HA05473A	Front Chassis Ass'y (TA-1E)	1
09	BA07273A	Headphone P.C.B. Ass'y	1
10	BA07314A	Power Switch P.C.B. Ass'y (TA-1 (Australia) & TA-1E)	1
	BA07275A	Power Switch P.C.B. Ass'y (TA-1 (Other) & TA-1A)	1
11	OJ05612A	Volume Ground Plate A	1
12	BA07274A	Monitor Switch P.C.B. Ass'y	1
13	BA07272A	Tone Control P.C.B. Ass'y	1
14	OJ05613A	Volume Ground Plate B	1
15	BA07270A	Volume P.C.B. Ass'y	1
16	BA07271A	Balance & Loudness P.C.B. Ass'y	1
17	OJ05393A	Side Chassis R	1
18	OB80203A	Glass Tube 3S 200mm	1
19	BA07277A	Speaker Terminal P.C.B. Ass'y (TA-1 & TA-1A)	1
	BA07342A	Speaker Terminal P.C.B. Ass'y (TA-1E)	1
20	OM05195A	Fuse Label T1A 125V (TA-1A)	1
21	OH05381A	Rear Panel (TA-1 (Australia))	1
	OH05380A	Rear Panel (TA-1 (Other))	1
	OH05314A	Rear Panel (TA-1A)	1
	OH05379A	Rear Panel (TA-1E)	1
22	BA07276A	AC Outlet P.C.B. Ass'y (TA-1 (Other) & TA-1A)	1
23	OB90280A	Cord Bushing	1
24	OB80148A	Power Cord (TA-1 (Australia))	1
	OB80199A	Power Cord SPT-2 (TA-1 (Other) & TA-1A)	1
	OB8093U	Power Cord (TA-1E)	1
25	OJ05611A	Ground Terminal	1
26	OJ05669A	Ground Knob	1
27	OB90316A	AM Antenna Holder	1
28	OB08515A	Insu-Lock	10
29	OB81928A	AC Outlet (TA-1 (Other) & TA-1A)	1
30	OB60591A	Voltage Selector P.C.B. (TA-1 (Other))	1
31	OB70138A	Voltage Selector (TA-1 (Other))	1
L01	OE03434A	BT 4x6 @ Binding	4
L02	OE00857A	BT 3x6 @ Binding	3
L03	OE03432A	BT 3x6 @ Tapping (Black Chromate)	5
L04	OJ05427A	Mounting Plate	1
L05	OE03382A	Nut Hex. M7	5
L06	OE03383A	Washer 7mm	5
L07	OE03375A	Nut Hex. M9	1
L08	OE03376A	Washer 9mm	1
L09	OE00868A	BT 3x8 @ Binding	5
L10	OE03433A	BT 3x6 @ Binding Projected (Black Chromate)	6
L11	OE00921A	BT 3x8 @ Binding (Black Chromate)	7
L12	OJ05673A	Nut 70 ZN3A	1
L13	OE00985A	M3x6 @ Binding (Black Chromate) (TA-1 (Other))	2
—	OJ05665A	Free-up Belt (TA-1 & TA-1E)	1
—	OJ05703A	Earth Lug (TA-1A)	1
—	OM04191A	Fuse Label (TA-1 (Australia) & TA-1E)	1
—	OM05220A	Fuse Label (TA-1 (Australia) & TA-1E)	1
—	OB83476A	Lead Wire 100mm (TA-1 (Other))	1
—	OE00037A	Earth Lug B-5 (TA-1E)	2
—	OE03069A	Earth Lug B-2 (TA-1E)	2
—	OE00862A	BT 3x6 @ Pan (TA-1E)	2

5.3. Heat Sink Ass'y (B01)

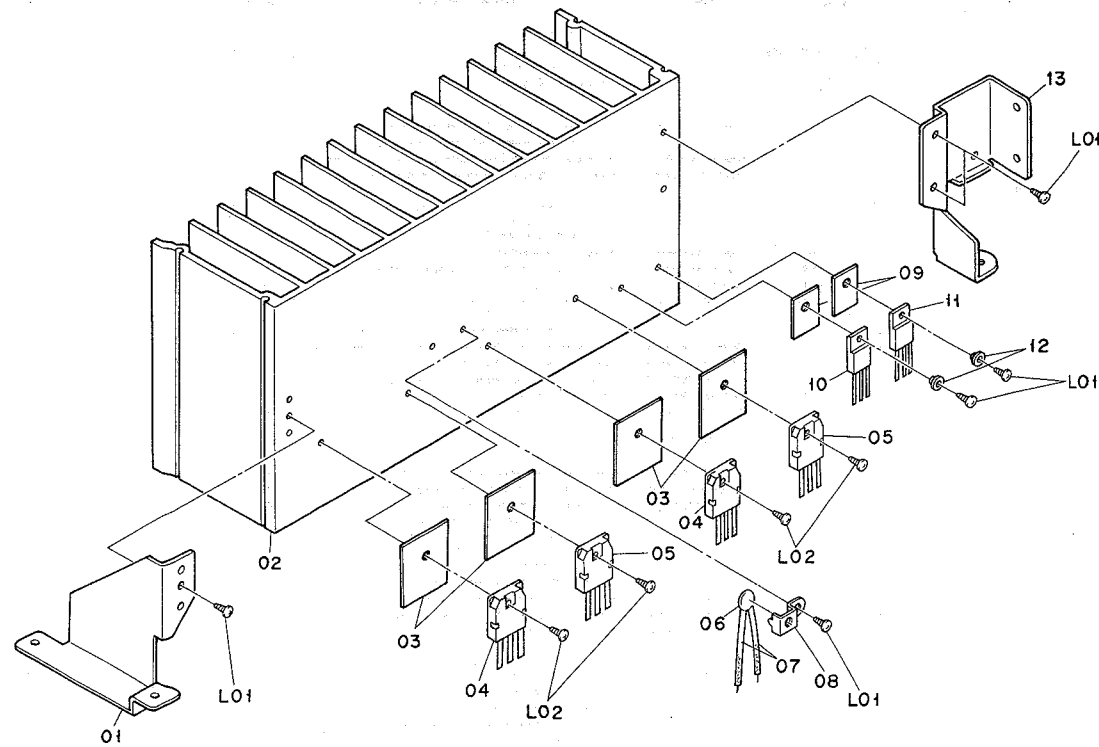

Fig. 5.3

Schematic Ref. No.	Part No.	Description	Q'ty
5.3. Heat Sink Ass'y			
B01	BA07309A	Heat Sink Ass'y	1
01	OJ05609A	Heat Sink Holder F	1
02	OJ05608A	Heat Sink	1
03	OJ05671A	Insulator TO-3P	4
04	0B10244A	TR 2SA1264N (O.R) [Q312L,R]	2
05	0B10245A	TR 2SC3181N (O.R) [Q311L,R]	2
06	0B19607A	Thermistor 50KD-5 [TH301]	1
07	0B80202A	Glass Tube 30	2
08	OJ05615A	Thermistor Holder	1
09	OJ05672A	Insulator TO-220	2
10	0B10248A	TR 2SD313 (E) [Q405]	1
11	0B11508A	IC MC7806CT [U401]	1
12	0B08594A	Transistor Bush	2
13	OJ05610A	Heat Sink Holder R	1
L01	0E00868A	BT3x8 @ Binding	6
L02	0E00865A	BT3x10 @ Binding	4

5.4. Front Chassis Ass'y (B02)

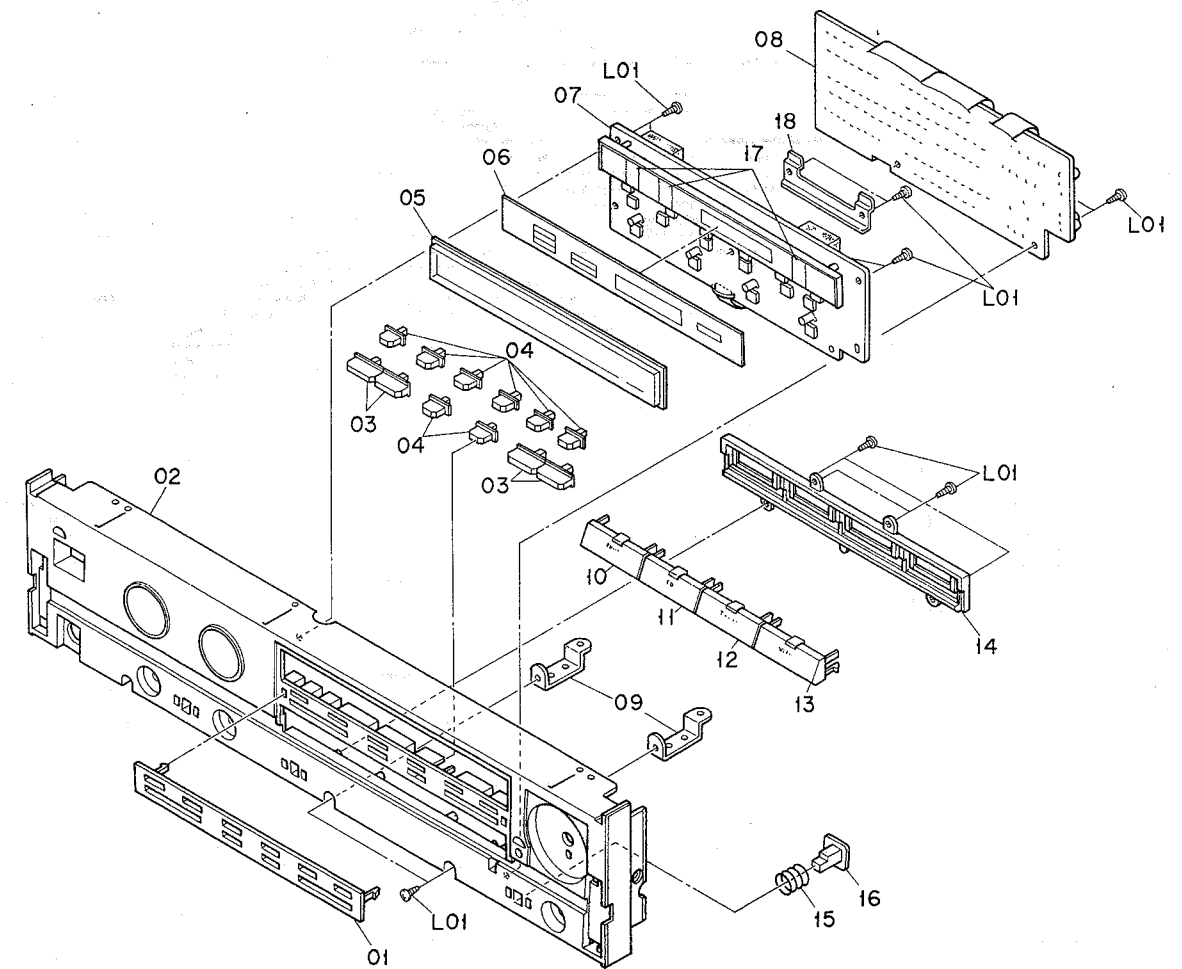

Fig. 5.4

Schematic Ref. No.	Part No.	Description	Q'ty
5.4. Front Chassis Ass'y			
B02	HA05445A	Front Chassis Ass'y (TA-1 & TA-1A)	1
	HA05473A	Front Chassis Ass'y (TA-1E)	1
01	0H05316A	Memory Plate	1
02	0H05328A	Front Chassis	1
03	0H05324A	Up/Down Button	4
04	0H05323A	Preset Button	8
05	0H05326A	Display Lens	1
06	0H05327A	Display Overlay	1
07	BA07279A	Control Switch & Display P.C.B. Ass'y (TA-1 & TA-1A)	1
	BA07313A	Control Switch & Display P.C.B. Ass'y (TA-1E)	1
08	BA07278A	Synthesizer P.C.B. Ass'y (TA-1 & TA-1A)	1
	BA07366A	Synthesizer P.C.B. Ass'y (TA-1E)	1
09	OJ05607A	P.C.B. Holder	2
10	HA05443A	Phono Button Ass'y	1
11	HA05467A	CD Button Ass'y	1
12	HA05468A	Tuner Button Ass'y	1
13	HA05469A	Video Button Ass'y	1
14	OJ05605A	Button Base	1
15	OJ05406A	Push Spring	1
16	0H05322A	Push Button	1
17	OJ05614A	Diffuser	3
18	OJ05749A	Front P.C.B. Holder	1
L01	0E00868A	BT3x8 @ Binding	15

6. MOUNTING DIAGRAMS AND PARTS LIST

- Notes: 1. Mounting diagram shows a dip side view of the printed circuit board.
 2. Diode is 1SS53, 1S1555, or 1SS176 unless otherwise specified.
 3. Following transistors are interchangeable with each other.
 a. 2SA733, 2SA608SP, 2SA1048, 2SA1175
 b. 2SC945, 2SC536SP, 2SC2458, 2SC2785
 4. Abbreviation for part name:
 TR — Transistor, SiD — Silicon Diode, ZD — Zener Diode, Varicap — Variable Capacitance Diode
 RK — Carbon Resistor, RM — Metal Film Resistor, RF — Fail Safe Type Resistor
 CE — Electrolytic Capacitor, CML — Mylar Capacitor, CC — Ceramic Capacitor, CPP — PP Capacitor,
 CMM — Metalized Mylar Capacitor, CSP — Polystyrene Capacitor, C — Mica Capacitor

6.1. AC Outlet P.C.B. Ass'y

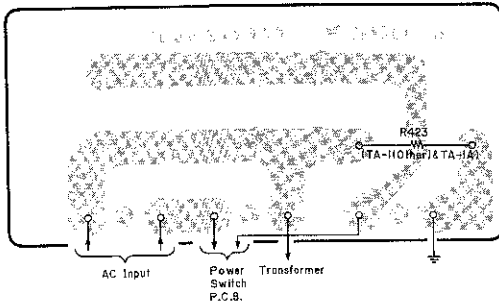

Fig. 6.1

6.2. Power Switch P.C.B. Ass'y

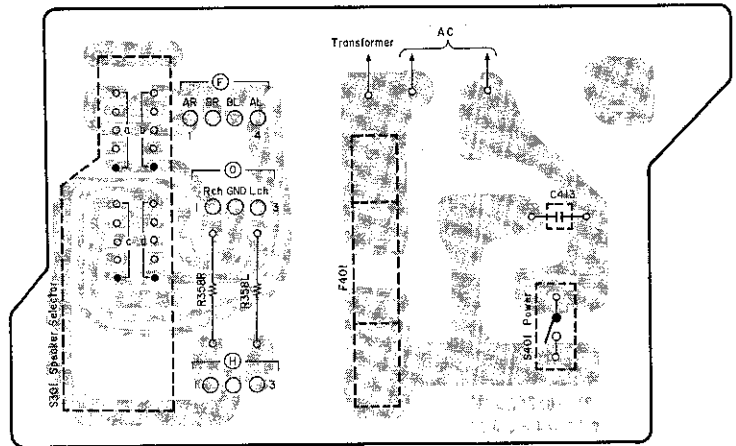

Fig. 6.2

6.3. Speaker Terminal P.C.B. Ass'y

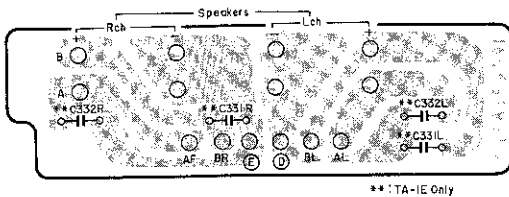

Fig. 6.3

Schematic Ref. No.	Part No.	Description	Schematic Ref. No.	Part No.	Description	Schematic Ref. No.	Part No.	Description
6.1. AC Outlet P.C.B. Ass'y			6.2. Power Switch P.C.B. Ass'y				0B81848A	Fuse Holder (TA-1E) (2)
	BA07276A	AC Outlet P.C.B. Ass'y (TA-1 (Other) & TA-1A)		BA07275A	Power Switch P.C.B. Ass'y (TA-1 & TA-1A)		0B80204A	Terminal Pin (1)
R423	0B60585A	AC Outlet P.C.B. RK 3.3M 1/2W J		BA07314A	Power Switch P.C.B. Ass'y (TA-1E)		0M05220A	Fuse Label T1.6A 250V (TA-1E) (1)
A-A	0B05919A	Lead Wire RED 300mm	R358L,R	0B60584A	Power Switch P.C.B. RF 330 1W J	6.3. Speaker Terminal P.C.B. Ass'y		
B-B	0B83366A	Lead Wire BRN 300mm	C413	0B24184A	Spark Killer 4700P 400V		BA07277A	Speaker Terminal P.C.B. Ass'y (TA-1 & TA-1A)
	0B83367A	Lead Wire BLK 140mm (1)	S301	0B41829A	Rotary Switch 4P4C		BA07342A	Speaker Terminal P.C.B. Ass'y (TA-1E)
	0B83363A		S401	0B70129A	Power Switch SDDL B		0B60586A	Speaker Terminal P.C.B.
			F401	0B90330A	Fuse T3A 250V (TA-1 (Other) & TA-1A)	C331L,R	0B05582A	CML 0.022μ 50V J (TA-1E)
			F401	0B90344A	Fuse 1R60CT S (TA-1 (Australia) & TA-1E)	C332L,R	0B05582A	CML 0.022μ 50V J (TA-1E)
				0B81930A	Fuse Holder SN-5051 (TA-1 & TA-1A) (2)	F-F	0B83360A	4P Ribbon Cable 240mm
							0B81929A	8P Speaker Terminal (1)

6.4. Headphone P.C.B. Ass'y

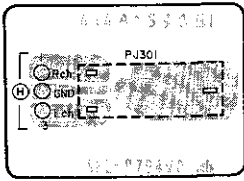

Fig. 6.4

6.5. Monitor Switch P.C.B. Ass'y

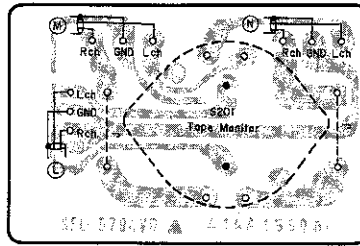

Fig. 6.5

6.6. Volume P.C.B. Ass'y

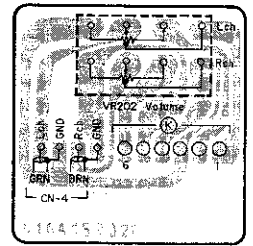

Fig. 6.6

6.7. Balance & Loudness P.C.B. Ass'y

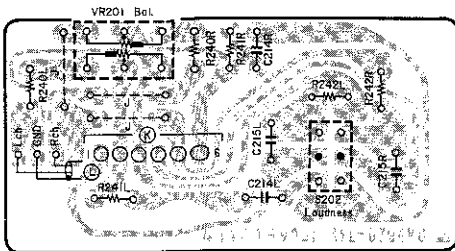

Fig. 6.7

6.8. Tone Control P.C.B. Ass'y

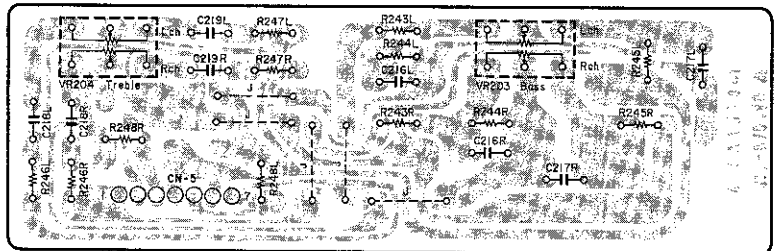

Fig. 6.8

Schematic Ref. No.	Part No.	Description	Schematic Ref. No.	Part No.	Description	Schematic Ref. No.	Part No.	Description		
6.4. Headphone P.C.B. Ass'y			6.6. Volume P.C.B. Ass'y			6.8. Tone Control P.C.B. Ass'y				
H-H PJ301	BA07273A	Headphone P.C.B. Ass'y	VR202 CN4 K-K	BA07270A	Volume P.C.B. Ass'y	VR203 VR204 R243L,R R244L,R R245L,R R246L,R R247L,R R248L,R C216L,R C217L,R C218L,R C219L,R CN5	BA07272A	Tone Control P.C.B. Ass'y		
	OB60582A	Headphone P.C.B.		OB60579A	Volume P.C.B.		OB60581A	Tone Control P.C.B.		
	OB83348A	3P Flat Cable BLK 140mm		OB30087A	VR 50K(B)x2		OB30089A	VR 250K (C)x2		
	OB81757A	Headphone Jack LJ0660-2		OB83349A	4P Connector Ass'y 240mm		OB30090A	VR 100K (C)x2		
OB80215A	UL Tube 80mm (1)	OB83352A	6P Flat Cable BLK 100mm	OB09700A	RK 9.1K 1/6W J		OB09714A	RK 36K 1/6W J		
6.5. Monitor Switch P.C.B. Ass'y			6.7. Balance & Loudness P.C.B. Ass'y				OB09683A	RK 1.8K 1/6W J	OB09683A	RK 1.8K 1/6W J
S201 L-L M-M N-N	BA07274A	Monitor Switch P.C.B. Ass'y	VR201 R240L,R R241L,R R242L,R C214L,R C215L,R S202	BA07271A	Balance & Loudness P.C.B. Ass'y		OB09668A	RK 430 1/6W J	OB09699A	RK 8.2K 1/6W J
	OB60583A	Monitor Switch P.C.B.		OB60580A	Balance & Loudness P.C.B.		OB41299A	CML 0.12μ 50V J	OB41306A	CML 0.47μ 50V J
	OB70128A	Rotary Switch MSB22BP		OB30088A	VR 250K (MN)x2		OB05659A	CML 5600P 50V J	OB05660A	CML 0.039μ 50V J
	OB83350A	Lead Wire RED 350mm		OB09685A	RK 2.2K 1/6W J		OB83353A	7P Flat Cable BLK 180mm		
	OB83369A	Lead Wire BRN 400mm		OB09687A	RK 2.7K 1/6W J					
	OB83368A	Lead Wire GRY 400mm	OB09695A	RK 5.6K 1/6W J						
			OB05653A	CML 1500P 50V J						
			OB01780A	CML 0.1μ 50V J						
			OB70127A	Push Switch PSR-221						

Schematic Ref. No.	Part No.	Description	Schematic Ref. No.	Part No.	Description
6.9. Control Switch & Display P.C.B. Ass'y			6.10. Synthesizer P.C.B. Ass'y		
	BA07279A	Control Switch & Display P.C.B. Ass'y (TA-1 & TA-1A)		BA07278A	Synthesizer P.C.B. Ass'y (TA-1 & TA-1A)
	BA07313A	Control Switch & Display P.C.B. Ass'y (TA-1E)		BA07366A	Synthesizer P.C.B. Ass'y (TA-1E)
Q601,602	OB60588A	Control Switch & Display P.C.B.	U501	OB60587A	Synthesizer P.C.B.
Q603,604	OB01872A	TR 2SC945L (P,Q) (TA-1E)	U502	OB11160A	IC TD6301AP
Q605,606	OB01872A	TR 2SC945L (P,Q) (TA-1E)	U503	OB11159A	IC TD6104P
Q607,608	OB01872A	TR 2SC945L (P,Q)	U504	OB11161A	IC TC9147BP
Q609	OB01872A	TR 2SC945L (P,Q)	Q501	OB06219A	IC μ PD4081BC
Q610	OB06013A	TR 2SA733 (P,Q)	Q502,503	OB01872A	TR 2SC945L (P,Q)
D601,602	OB12584A	SID 1N4148 (TA-1E)	Q504,505	OB10097A	TR 2SA952L (K,L)
D603,604	OB12584A	SID 1N4148	Q506	OB01872A	TR 2SC945L (P,Q)
D605,606	OB12584A	SID 1N4148	Q507,508	OB06013A	TR 2SA733 (P,Q)
D607,608	OB12584A	SID 1N4148	Q509,510	OB01872A	TR 2SC945L (P,Q)
D609,610	OB12584A	SID 1N4148	Q511	OB01872A	TR 2SC945L (P,Q)
D611,612	OB12584A	SID 1N4148	D501	OB12584A	SID 1N4148
D613,614	OB12584A	SID 1N4148	D502	OB12584A	SID 1N4148
D615,616	OB12584A	SID 1N4148	D503,504	OB12584A	SID 1N4148
ED617,618	OB12395A	LED SLR-34PC3F	D505,506	OB12584A	SID 1N4148
ED619,620	OB12395A	LED SLR-34PC3F	D507,508	OB12584A	SID 1N4148
ED621,622	OB12395A	LED SLR-34PC3F	D509	OB12584A	SID 1N4148
ED623,624	OB12395A	LED SLR-34PC3F	D510,511	OB12584A	SID 1N4148
ED625,626	OB12395A	LED SLR-34PC3F	D512	OB12584A	SID 1N4148
DP601	OB12608A	Display Unit LTF-2401 KLR (TA-1 & TA-1A)	X501	OB92006A	X'tal 7.2MHz
		Display Unit LTF-2501 (TA-1E)	L501	OB51277A	Motor Choke Coil 1mH K
R601,602	OB09701A	RK 10K 1/6W J (TA-1E)	R501	OB09655A	RK 120 1/6W J
R603	OB09662A	RK 240 1/6W J	R502,503	OB09662A	RK 240 1/6W J
R604	OB09661A	RK 220 1/6W J (TA-1E)	R504,505	OB09662A	RK 240 1/6W J
R605,606	OB09693A	RK 4.7K 1/6W J (TA-1E)	R506,507	OB09662A	RK 240 1/6W J
R607	OB09701A	RK 10K 1/6W J (TA-1E)	R508,509	OB09662A	RK 240 1/6W J
R608,609	OB09655A	RK 120 1/6W J (TA-1E)	R510,511	OB09662A	RK 240 1/6W J
R610	OB09655A	RK 120 1/6W J (TA-1E)	R512,513	OB09662A	RK 240 1/6W J
R611,612	OB09659A	RK 180 1/6W J	R514,515	OB09662A	RK 240 1/6W J
R613	OB09661A	RK 220 1/6W J	R516,517	OB09662A	RK 240 1/6W J
R614,615	OB09709A	RK 22K 1/6W J	R518,519	OB09662A	RK 240 1/6W J
R616,617	OB09709A	RK 22K 1/6W J	R520,521	OB09662A	RK 240 1/6W J
R618,619	OB09693A	RK 4.7K 1/6W J	R522	OB09662A	RK 240 1/6W J
R620,621	OB09693A	RK 4.7K 1/6W J	R523,524	OB09725A	RK 100K 1/6W J
R622,623	OB09701A	RK 10K 1/6W J	R525,526	OB09725A	RK 100K 1/6W J
R624	OB09701A	RK 10K 1/6W J	R527,528	OB09701A	RK 10K 1/6W J
R625	OB09683A	RK 1.8K 1/6W J	R529,530	OB09689A	RK 3.3K 1/6W J
R626	OB05578A	RK 180 1/4W J	R531,532	OB09725A	RK 100K 1/6W J
R627	OB09657A	RK 150 1/6W J	R533	OB09725A	RK 100K 1/6W J
R628,629	OB09659A	RK 180 1/6W J	R534	OB09677A	RK 1K 1/6W J
R630	OB09657A	RK 150 1/6W J	R535,536	OB09701A	RK 10K 1/6W J
R631,632	OB09701A	RK 10K 1/6W J	R537	OB09701A	RK 10K 1/6W J
S601,602	OB70130A	Tact Switch R66-3818	R538,539	OB09725A	RK 100K 1/6W J
S603,604	OB70130A	Tact Switch R66-3818	R540	OB09677A	RK 1K 1/6W J
S605,606	OB70130A	Tact Switch R66-3818	R541	OB09701A	RK 10K 1/6W J
S607,608	OB70130A	Tact Switch R66-3818	R542	OB09699A	RK 8.2K 1/6W J
S609,610	OB70130A	Tact Switch R66-3818	R543	OB09721A	RK 68K 1/6W J
S611,612	OB70130A	Tact Switch R66-3818	R544	OB09718A	RK 51K 1/6W J
S613,614	OB70130A	Tact Switch R66-3818	R545	OB09725A	RK 100K 1/6W J
S615,616	OB70130A	Tact Switch R66-3818	R546	OB09719A	RK 56K 1/6W J
CN6	OB83351A	5P Flat Cable BLK 240mm	R547,548	OB09749A	RK 1M 1/6W J
		Insu-Lock (1)	R549,550	OB09749A	RK 1M 1/6W J
		BT3x8 \oplus Binding (2)	R551	OB09701A	RK 10K 1/6W J
		LED Reflector A132 (4)	R552,553	OB09719A	RK 56K 1/6W J
		Display Reflector (1)	R554,555	OB09725A	RK 100K 1/6W J
			R556	OB09725A	RK 100K 1/6W J
			R557,558	OB09701A	RK 10K 1/6W J
			R559	OB09725A	RK 100K 1/6W J
			C501	OB01405A	CE 1 μ 50V
			C502	OB09291A	CC 0.022 μ 50V Z
			C503	OB09288A	CC 1000P 50V K
			C504	OB01403A	CE 47 μ 16V
			C505	OB09291A	CC 0.022 μ 50V Z
			C506	OB41900A	CC 39P 50V J
			C507	OB09586A	CC 2200P 50V K
			C508,509	OB09290A	CC 0.01 μ 50V Z
			C510	OB01403A	CE 47 μ 16V
			C511	OB09327A	CE 0.33 μ 50V (LN)
			C512	OB41298A	CML 0.1 μ 50V J
			C513	OB09290A	CC 0.01 μ 50V Z
			C514	OB40501A	CE 0.1F 5.5V
			C515	OB09291A	CC 0.022 μ 50V Z
			C516,517	OB41740A	CC 33P 50V J
			C518,519	OB01405A	CE 1 μ 50V
			C520,521	OB09291A	CC 0.022 μ 50V Z
			C522,523	OB09291A	CC 0.022 μ 50V Z
			C524,525	OB09291A	CC 0.022 μ 50V Z
			C526,527	OB09288A	CC 1000P 50V K
			C528	OB09288A	CC 1000P 50V K

6.9. Control Switch & Display P.C.B. Ass'y

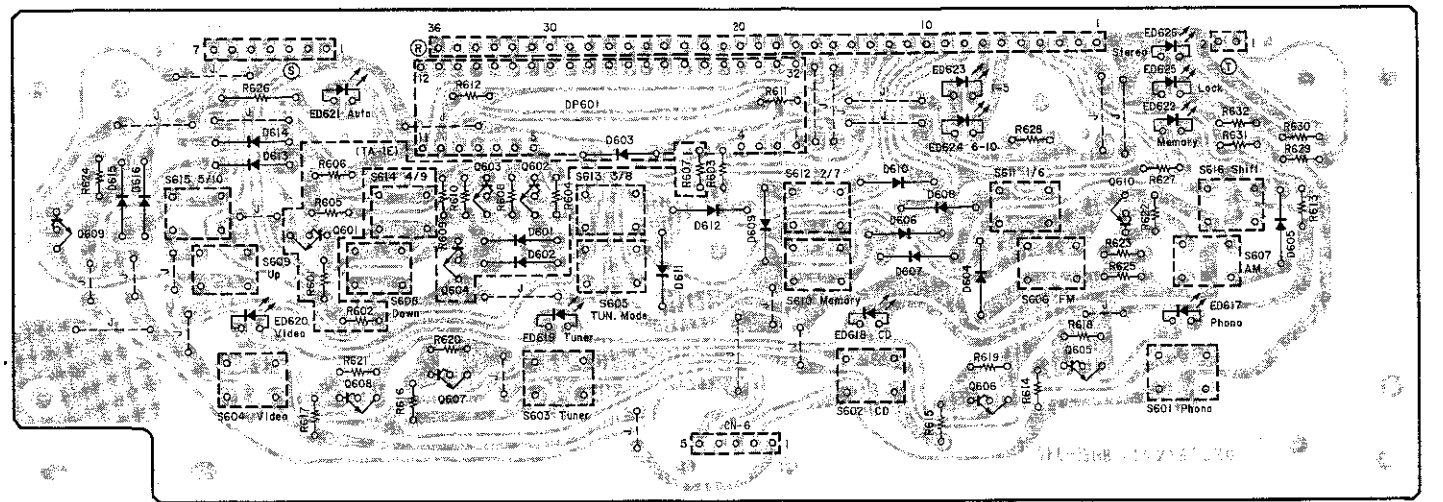

Fig. 6.9

6.10. Synthesizer P.C.B. Ass'y

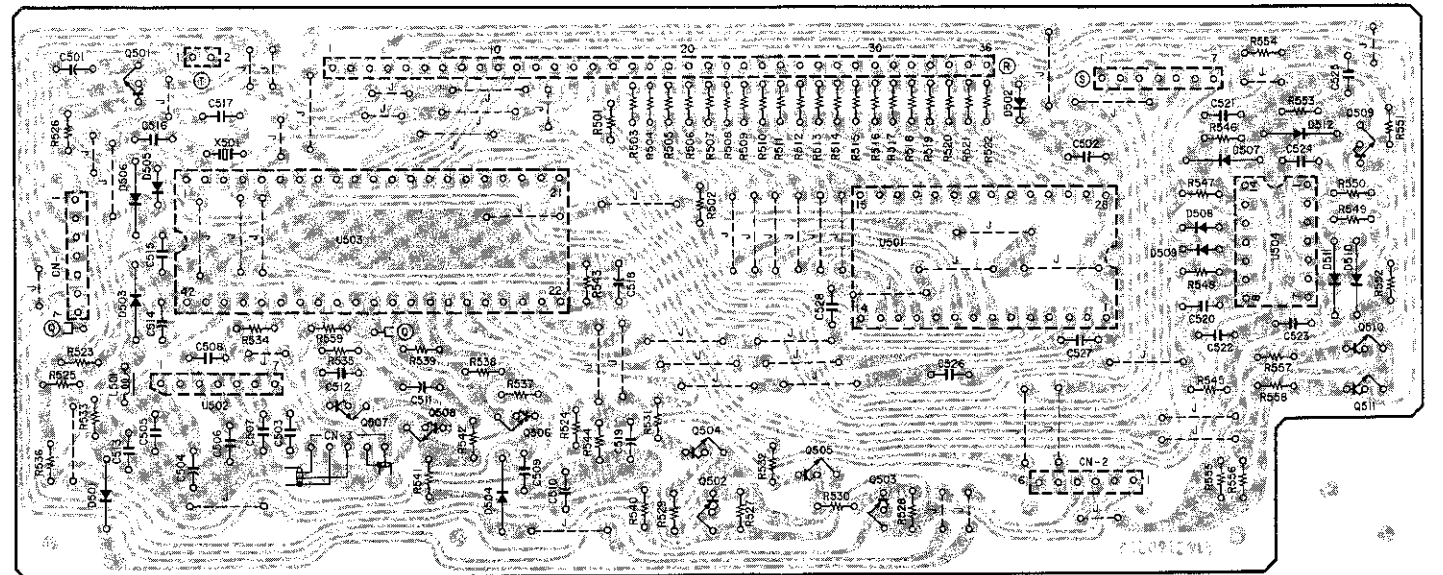

Fig. 6.10

Schematic Ref. No.	Part No.	Description
CN1	OB83355A	7P Flat Cable BLK 240mm
CN2	OB83354A	5P Flat Cable BLK 300mm (TA-1 & TA-1A)
	OB83479A	6P Flat Cable BLK 300mm (TA-1E)
CN3	OB83347A	5P Connector Ass'y 350mm
Q-Q	OB83364A	Lead Wire BRN 80mm
R-R	OB83356A	18P Flat Cable GRN 50mm
S-S	OB83357A	7P Flat Cable GRN 50mm
T-T	OB83358A	2P Ribbon Cable 50mm
	OB08515A	Insu-Lock (3)

6.11. Main P.C.B. Ass'y

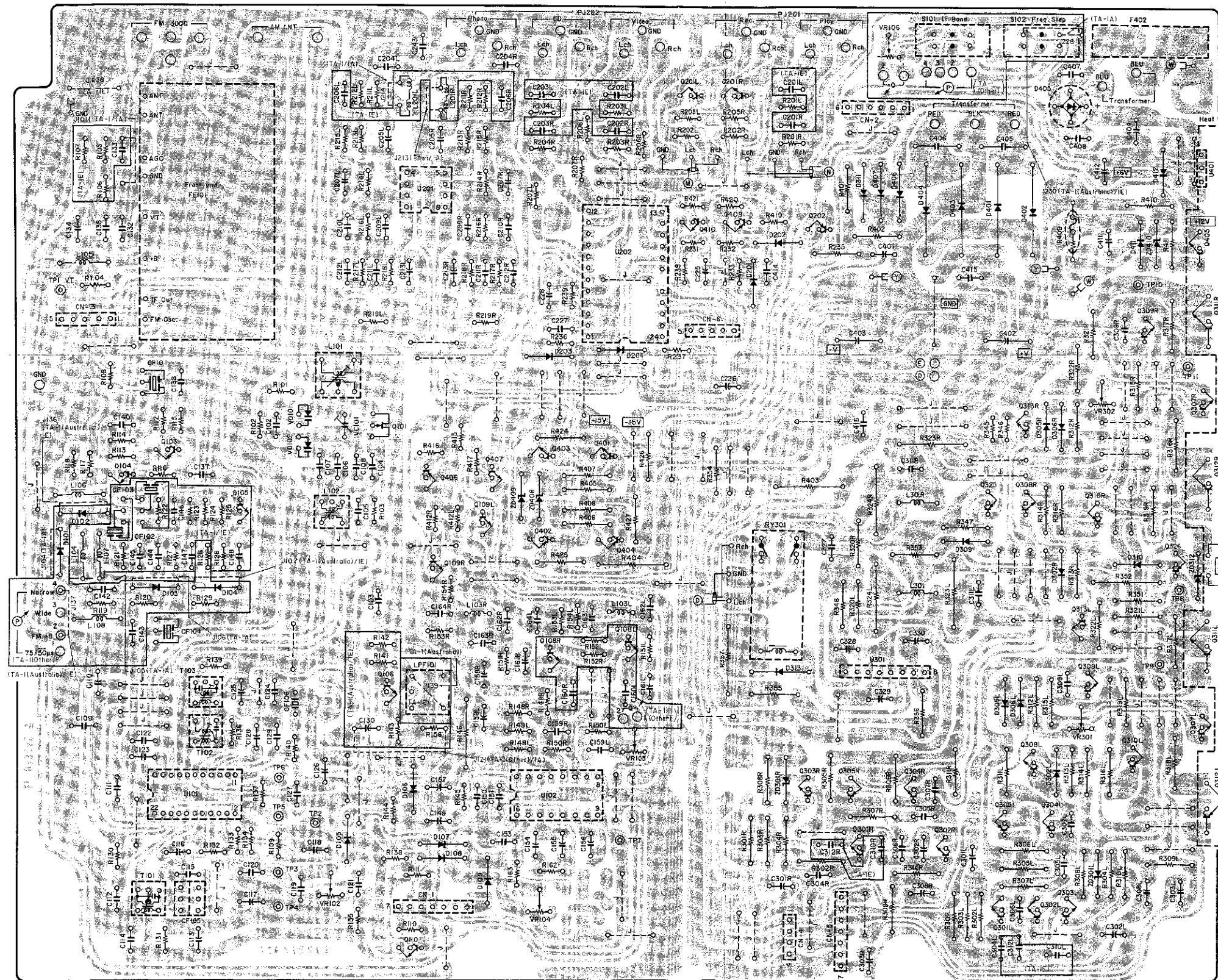

Fig. 6.11

Schematic Ref. No.	Part No.	Description
6.11. Main P.C.B. Ass'y		
	BA07312A	Main P.C.B. Ass'y (TA-1 (Australia))
	BA07310A	Main P.C.B. Ass'y (TA-1 (Other))
	BA07269A	Main P.C.B. Ass'y (TA-1A)
	BA07311A	Main P.C.B. Ass'y (TA-1E)
	Main P.C.B.	
U101	OB11504A	IC LA1265
U102	OB11505A	IC μ PC1235C
U201	OB06387A	IC NJM2043DD
U202	OB11506A	IC TC9152P
U301	OB11246A	IC μ PC1237H
Q101	OB10249A	FET 2SK161 (GR)
Q103,104	OB06115A	TR 2SC1675 (K,L)
Q105	OB06115A	TR 2SC1675 (K,L) (TA-1 & TA-1E)
Q106	OB01872A	TR 2SC945L (P,Q) (TA-1 (Australia) & TA-1E)
Q108L,R	OB01872A	TR 2SC945L (P,Q) (TA-1 (Other))
Q109L,R	OB06299A	TR 2SC2878
Q110	OB01872A	TR 2SC945L (P,Q)
Q201L,R	OB06299A	TR 2SC2878
Q202	OB06013A	TR 2SA733 (P,Q)
Q301L,R	OB06142A	TR 2SC2240 (BL)
Q302L,R	OB06142A	TR 2SC2240 (BL)
Q303L,R	OB06142A	TR 2SC2240 (BL)
Q304L,R	OB10050A	TR 2SA970 (BL)
Q305L,R	OB10050A	TR 2SA970 (BL)
Q307L,R	OB06142A	TR 2SC2240 (BL)
Q308L,R	OB06142A	TR 2SC2240 (BL)
Q309L,R	OB10247A	TR 2SC2235 (Y)
Q310L,R	OB10246A	TR 2SA965 (Y)
Q313L,R	OB06142A	TR 2SC2240 (BL)
Q325	OB10050A	TR 2SA970 (BL)
Q326	OB06372A	TR 2SA953L (K,L)
Q401	OB01872A	TR 2SC945L (P,Q)
Q402	OB06013A	TR 2SA733 (P,Q)
Q403	OB01872A	TR 2SC945L (P,Q)
Q404	OB06013A	TR 2SA733 (P,Q)
Q406	OB06013A	TR 2SA733 (P,Q)
Q407	OB01872A	TR 2SC945L (P,Q)
Q409	OB06013A	TR 2SA733 (P,Q)
Q410	OB01872A	TR 2SC945L (P,Q)
ZD301L,R	OB12613A	ZD 4.7V RD4.7EB23
ZD312	OB06290A	ZD 5.6V RD5.6 EB2
ZD408,409	OB12615A	ZD 15V RD15EB2
ZD410	OB12614A	ZD 12V RD12EB2
D101,102	OB12584A	SiD 1N4148 (TA-1 (Other))
D103,104	OB12584A	SiD 1N4148 (TA-1 (Other))
D105,106	OB12584A	SiD 1N4148
D107,108	OB12584A	SiD 1N4148
D109	OB12584A	SiD 1N4148
D201,202	OB12584A	SiD 1N4148
D203,204	OB12584A	SiD 1N4148
D302L,R	OB12584A	SiD 1N4148
D305L,R	OB12584A	SiD 1N4148
D306L,R	OB12584A	SiD 1N4148
D309,310	OB12584A	SiD 1N4148
D311	OB12586A	SiD 1N4002
D313	OB12586A	SiD 1N4002
D401,402	OB12605A	SiD 1N5402
D403,404	OB12605A	SiD 1N5402
D405	OB12604A	Diode Bridge W02M
D406,407	OB12586A	SiD 1N4002
D411	OB12584A	SiD 1N4148
D412	OB12584A	SiD 1N4148
VD101,102	OB12606A	Vari-Cap KV1236Z1
CF101	OB41899A	Ceramic Filter SFE10.7MA5-RED
CF102,103	OB41928A	Ceramic Filter (TA-1 & TA-1E)
CF104	OB41899A	Ceramic Filter SFE10.7MA5-RED
CF105	OB41897A	Ceramic Filter SAZ450B
CF106	OB41898A	Ceramic Filter BFU450CN
LPF101	OB51289A	Low Pass Filter (TA-1E)

7. SCHEMATIC DIAGRAMS

7.1. IC Block Diagrams

o.	Description	Schematic Ref. No.	Part No.	Description
2A	CML 4700P 50V J		OB81931A	Antenna Terminal (TA-1 & TA-1A) (1)
3A	CP 470P 100V J		OB81979A	Antenna Terminal (TA-1E) (1)
4A	CML 1500P 50V J		OB83362A	Lead Wire BLK 180mm (1)
5A	CSP 150P 50V J		OB83482A	Terminal Pin (L) (TA-1E) (4)
6A	CE 1μ 50V		OM04191A	Fuse Label T1A 250V (TA-1E) (1)
7A	CE 47μ 16V			
8A	CE 2200μ 16V			
9A	CC 0.022μ 50V Z			
10A	CE 0.47μ 50V			
11A	CML 0.1μ 50V K (TA-1 & TA-1A)			
12A	CC 0.047μ 50V Z (TA-1E)			
13A	CE 1μ 50V (LN)			
14A	CE 2.2μ 50V (LN)			
15A	CE 10μ 25V			
16A	CPP 330P 100V J			
17A	CML 1000P 50V J			
18A	CC 10P 50V D			
19A	CSP 56P 50V J			
20A	CE 100μ 10V			
21A	CSP 100P 50V J			
22A	CSP 220P 100V J (TA-1E)			
23A	CML 0.047μ 50V J			
24A	CC 100P 50V J (TA-1E)			
25A	CE 100μ 16V (BP)			
26A	CE 2.2μ 50V			
27A	CE 4.7μ 50V			
28A	CE 100μ 16V			
29A	CE 2.2μ 50V			
30A	CE 6800μ 50V			
31A	CE 1000μ 16V			
32A	CC 0.022μ 500V Z			
33A	CC 0.022μ 50V Z			
34A	CE 470μ 16V			
35A	CE 100μ 16V			
36A	CC 0.022μ 50V Z			
37A	CML 0.047μ 50V J			
38A	Relay VB-24MBU			
39A	Slide Switch 2-2 (TA-1 (Other))			
40A	Fuse T1A 250V (TA-1 (Australia) & TA-1E)			
41A	Fuse T1A 125V (TA-1 (Other) & TA-1A)			
42A	4P RCA Jack			
43A	6P RCA Jack			
44A	7P Post			
45A	6P Post			
46A	(TA-1 & TA-1E)			
47A	5P Post (TA-1A)			
48A	5P-T Post			
49A	4P-T Post			
50A	7P Post			
51A	5P Post			
52A	2P Ribbon Cable 220mm			
53A	Front-end FE306-A14 (TA-1 & TA-1A)			
54A	Front-end FE407-G58 (TA-1E)			
55A	3P Ribbon Cable 500mm			
56A	4P Ribbon Cable 400mm (TA-1 (Other))			
57A	2P Ribbon Cable 200mm (TA-1 (Other))			
58A	Lead Wire BLK 100mm			
59A	Lead Wire BLK 60mm			
60A	Silicon Tube 1φ 8m/m (for R317L,R) (4)			
61A	Silicon Tube 1φ 8m/m (for R318L,R) (4)			
62A	Terminal Pin (K) (27)			
63A	Fuse Holder Z-N1152-02 (2)			

Heat Sink Ass'y

U401	OB11508A	IC MC7806CT
Q311L,R	OB10245A	TR 2SC318N (O.R)
Q312L,R	OB10244A	TR 2SA1264N (O.R)
Q405	OB10248A	TR 2SD313 (E)
TH301	OB19607A	Thermistor 50KD-5
	OJ05609A	Heat Sink Holder F (1)
	OJ05608A	Heat Sink (1)
	OJ05671A	Insulator TO-3P (4)
	OB80202A	Glass Tube 30 (2)
	OJ05615A	Thermistor Holder (1)
	OJ05672A	Insulator TO-220 (2)
	OB08594A	Transistor Bush (2)
	OJ05610A	Heat Sink Holder R (1)
	OE00868A	BT3x8 @ Binding (6)
	OE00865A	BT3x10 @ Binding (4)

Note: Refer to 5.3. Heat Sink Ass'y (B01).

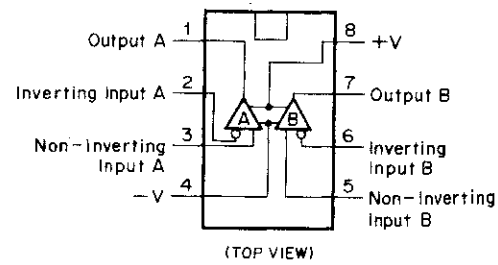

Fig. 7.1.1 Operational Amp. IC NJM2043DD

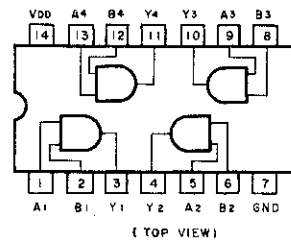

Fig. 7.1.2 AND Gate C-MOS IC μPD4081BC

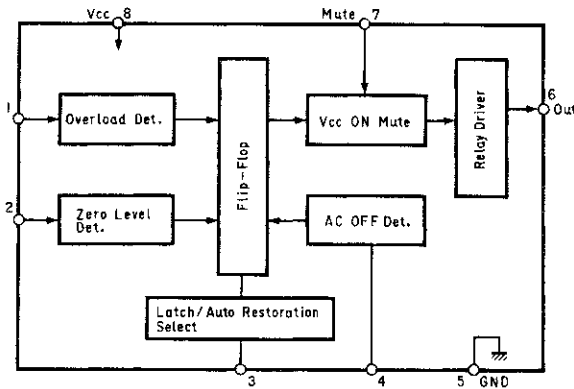

Fig. 7.1.3 Power Amp. Protector IC μPC1237H

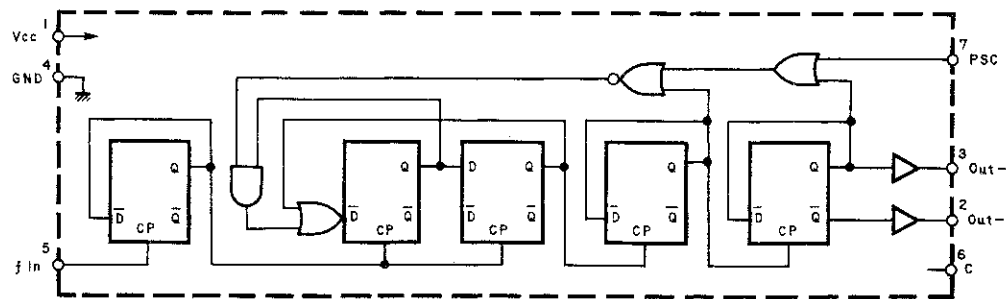

Fig. 7.1.4 ECL Prescaler (FM) IC TD6104P

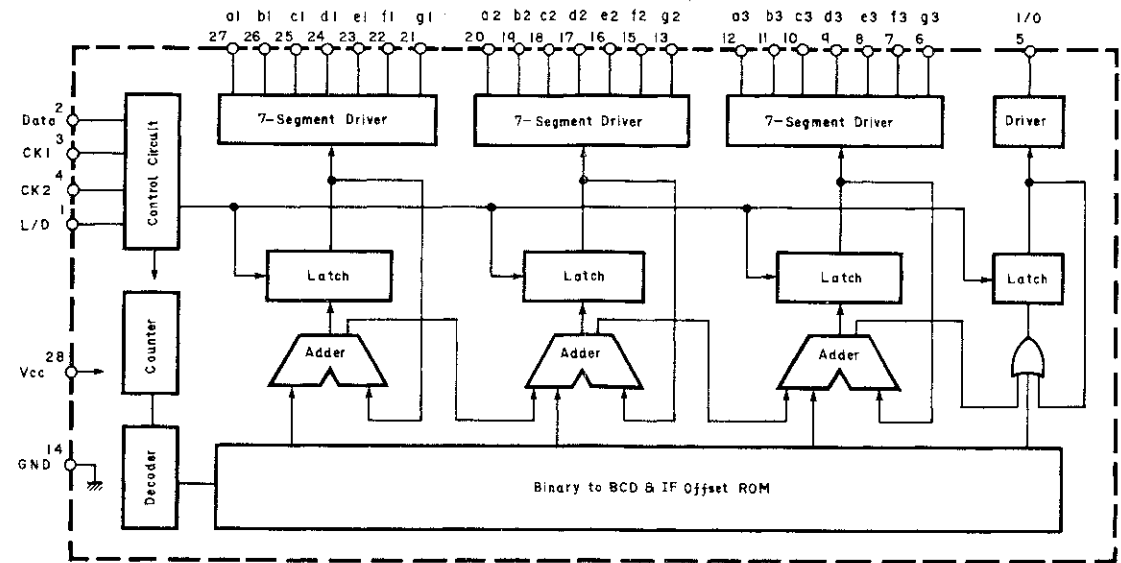

Fig. 7.1.5 Display Driver TD6301AP

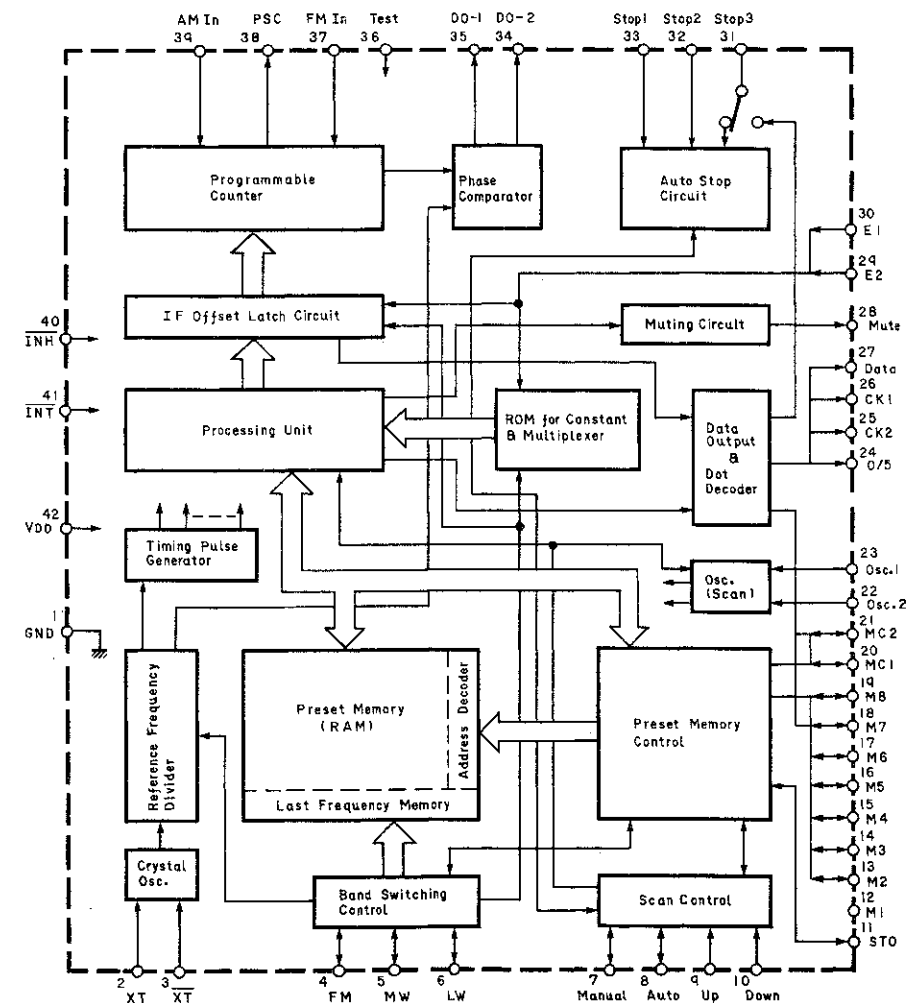

Fig. 7.1.6 PLL Synthesizer IC TC9147BP

7.2. Schematic Diagrams
7.2.1. Tuner Section

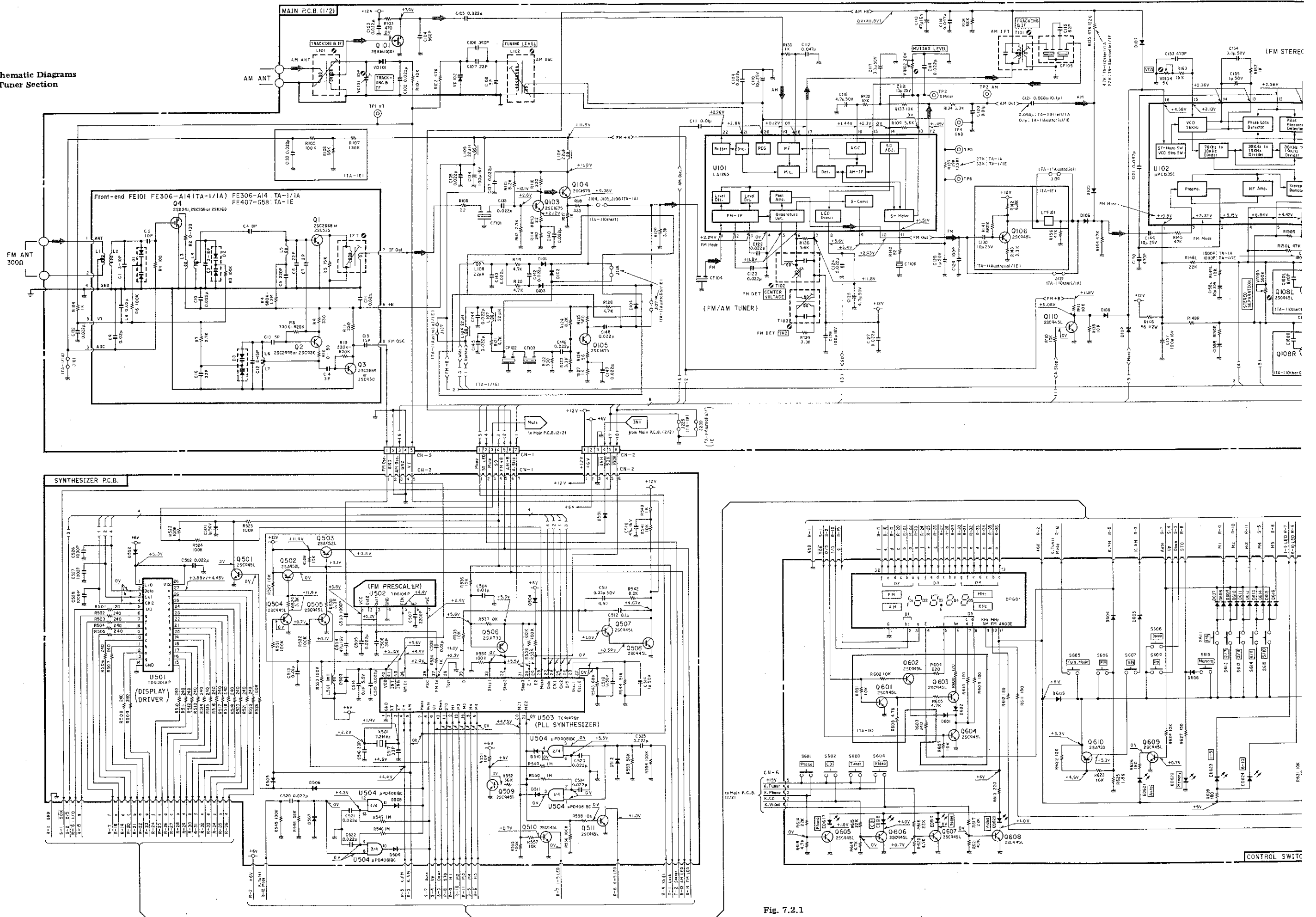
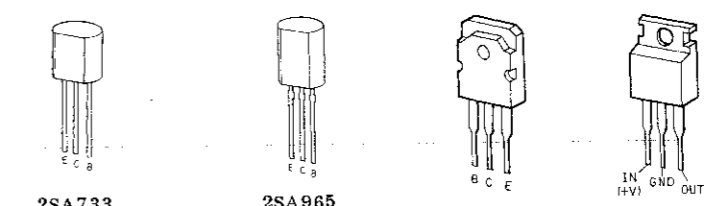
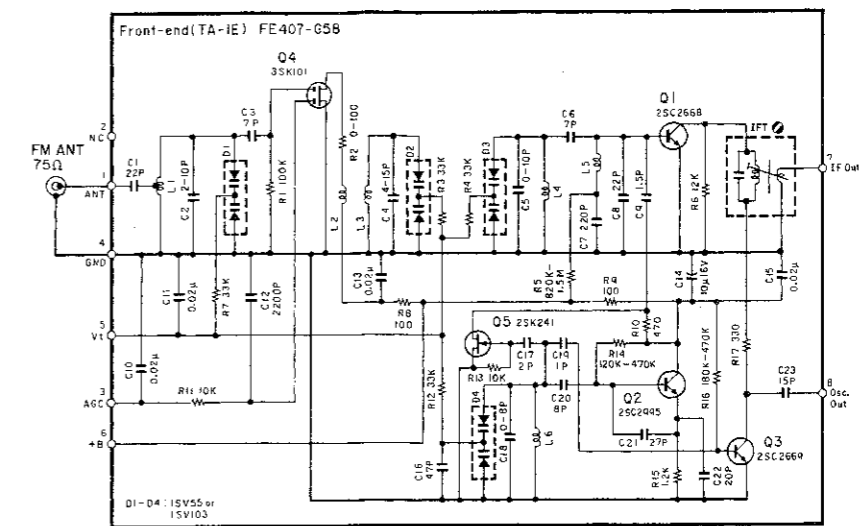
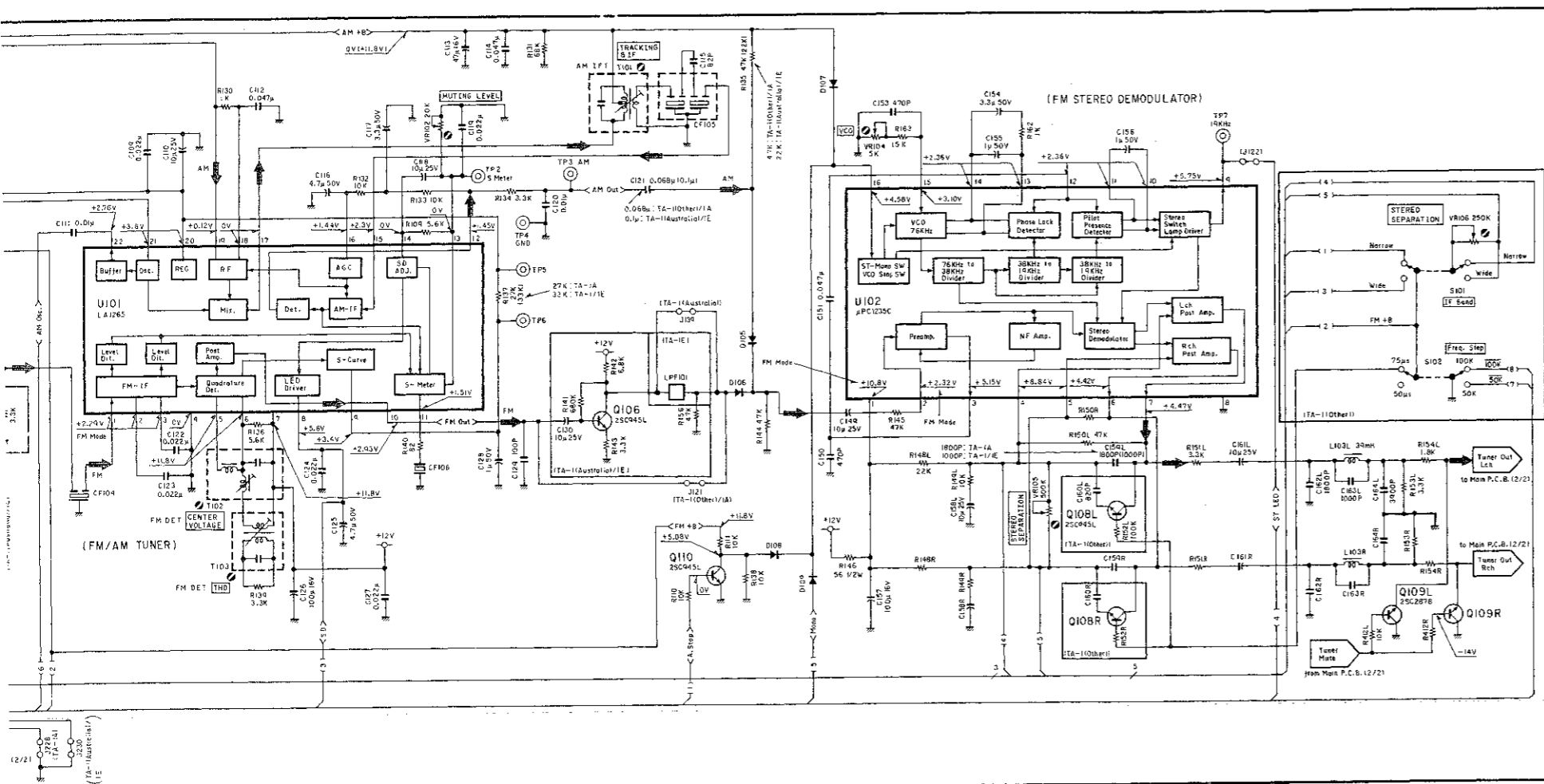

Fig. 7.2.1



- 2SA733
- 2SA952
- 2SA953
- 2SA970
- 2SC945
- 2SC1675
- 2SC2240
- 2SC2878
- 2SA965
- 2SC2235
- 2SA1264
- 2SC3181
- 2SD313
- 2SK161

- Notes:
1. Diode is 1N4148 unless otherwise specified.
 2. 2SA733, 2SA608SP, 2SA1048 and 2SA1175 are interchangeable with each other.
 3. 2SC945, 2SC536SP, 2SC2458 and 2SC2785 are interchangeable with each other.
 4. Parts marked with ** indicate those for TA-1E.
 5. Voltage measuring conditions
 - With no input signal applied to the input terminals.
 - With no lead connected to the speaker terminals.

Fig. 7.2.1

7.2.2. Amplifier Section

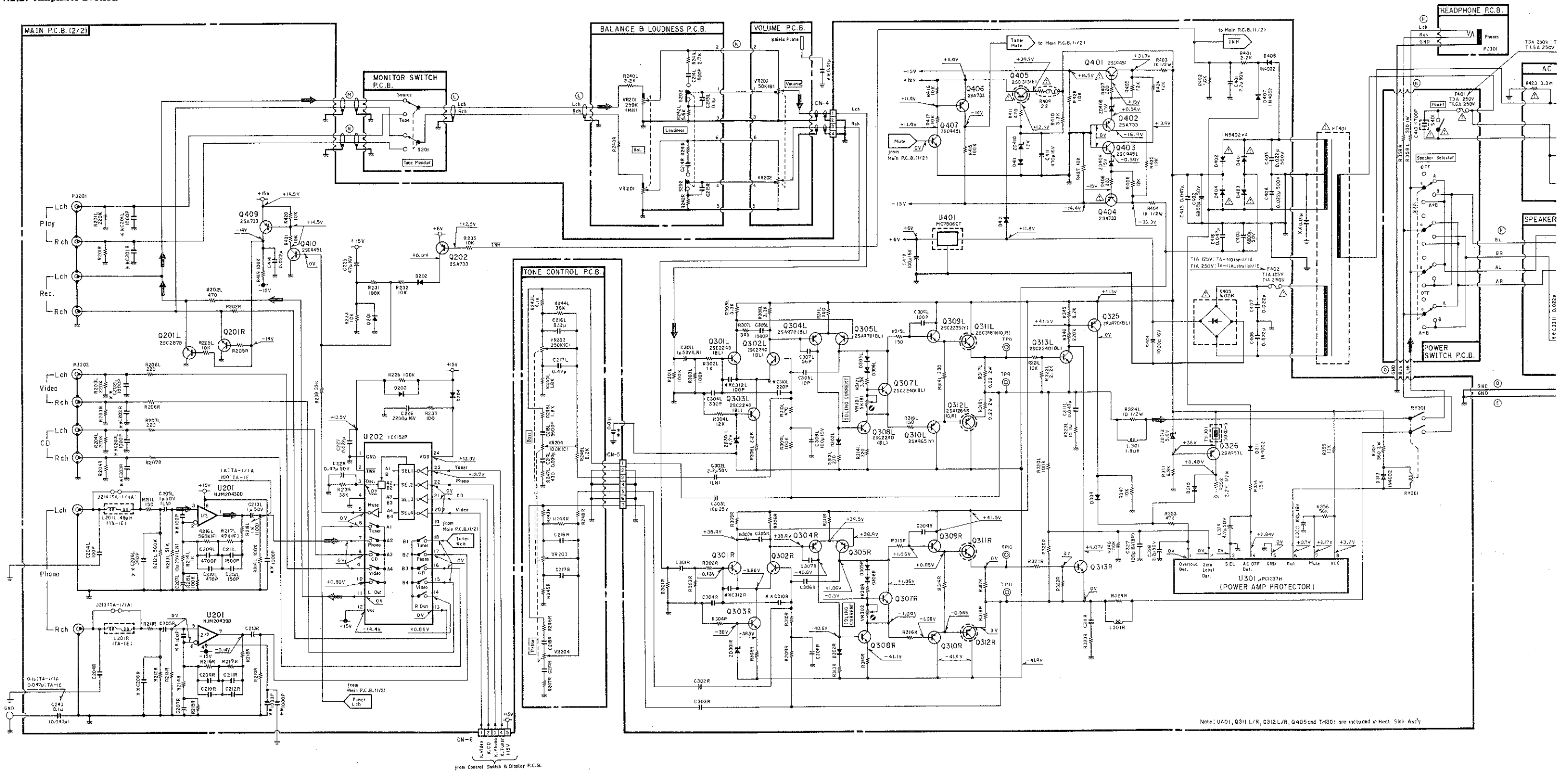

Fig. 7.2.2.

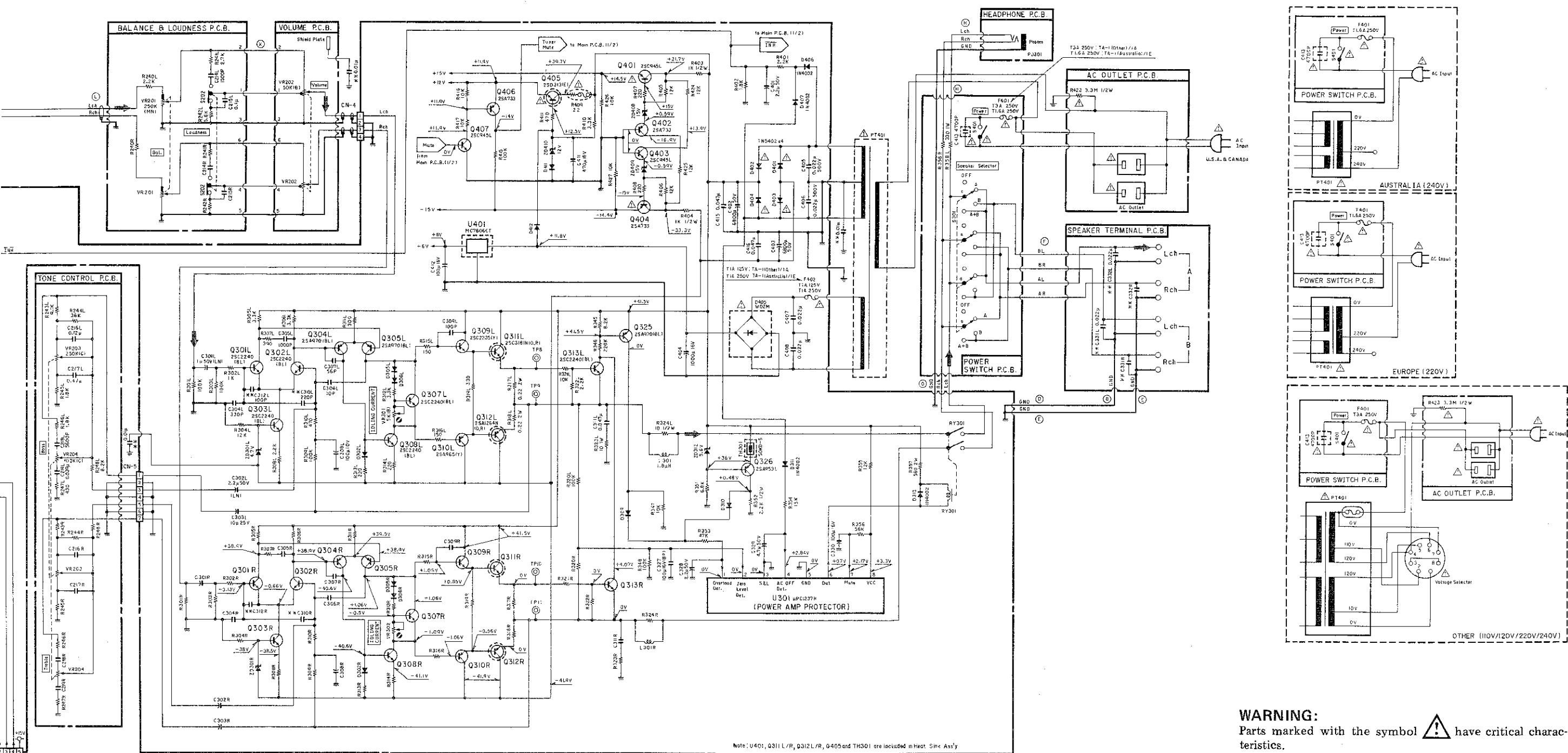

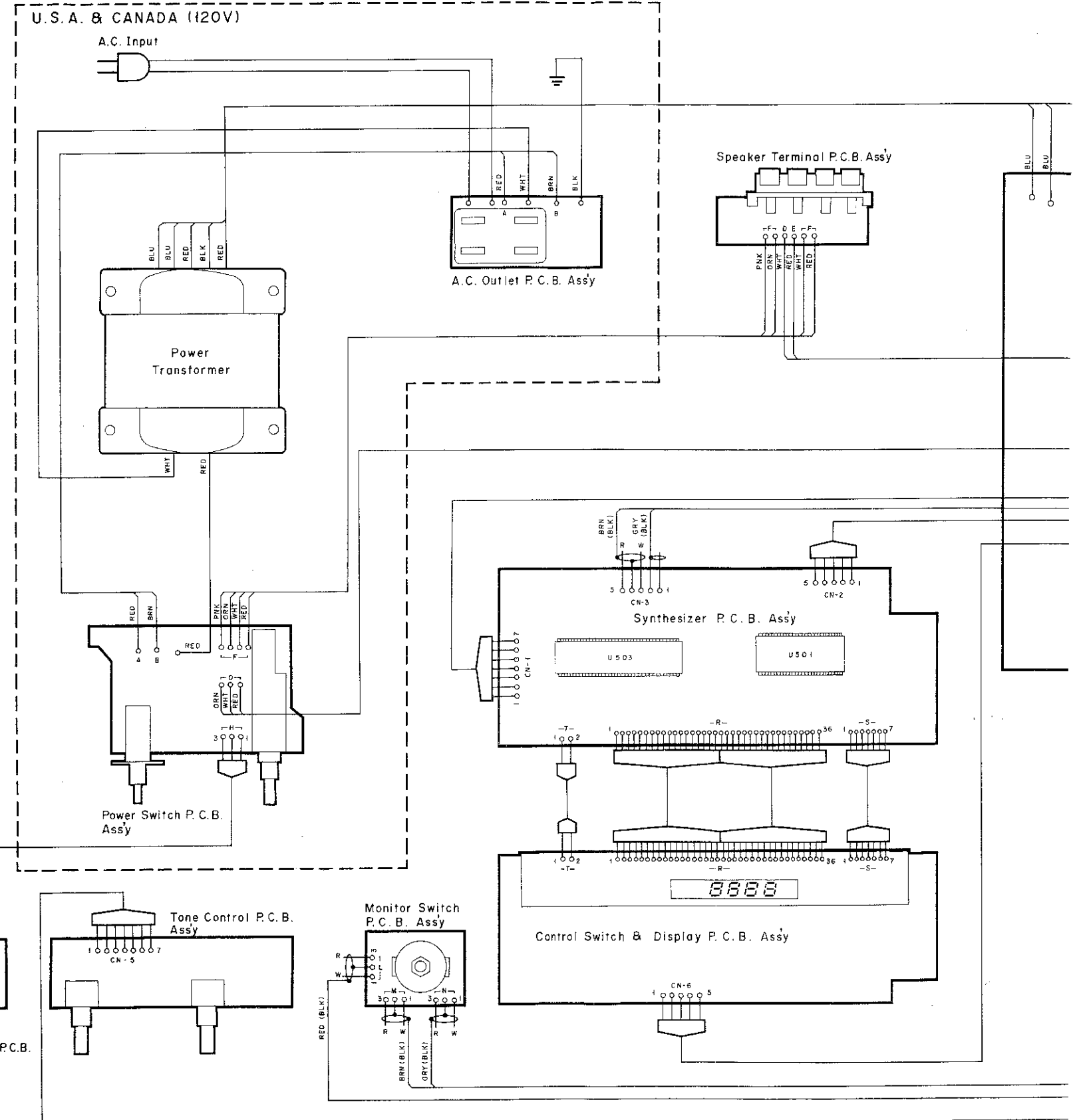
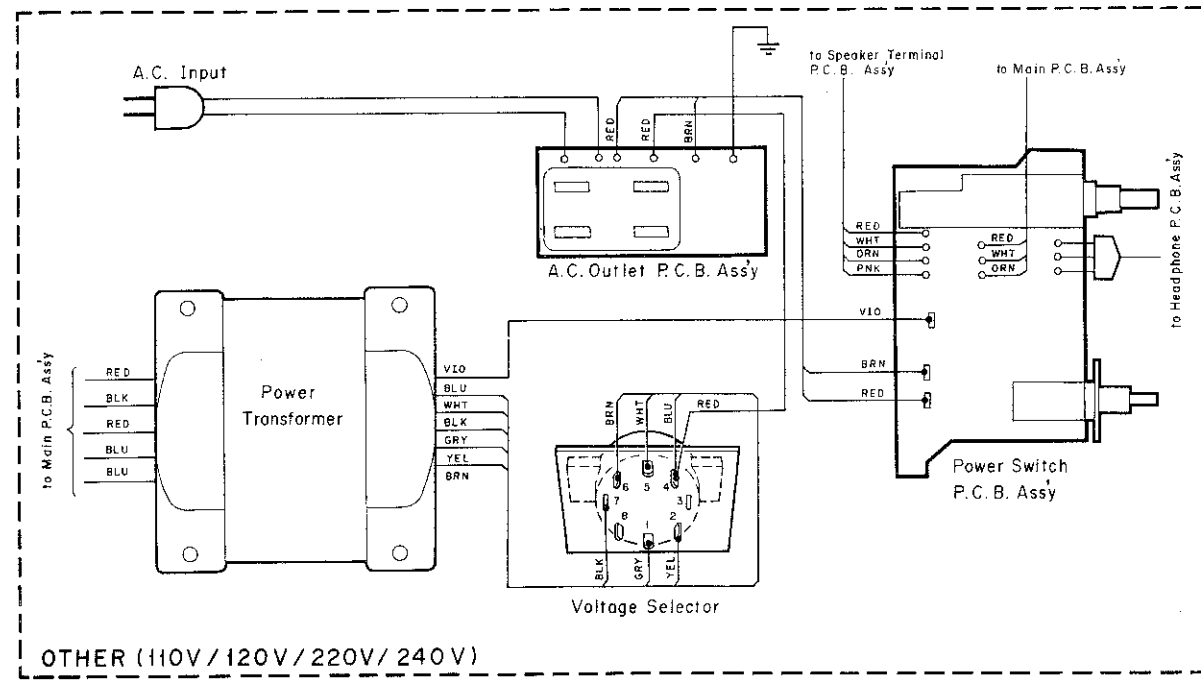
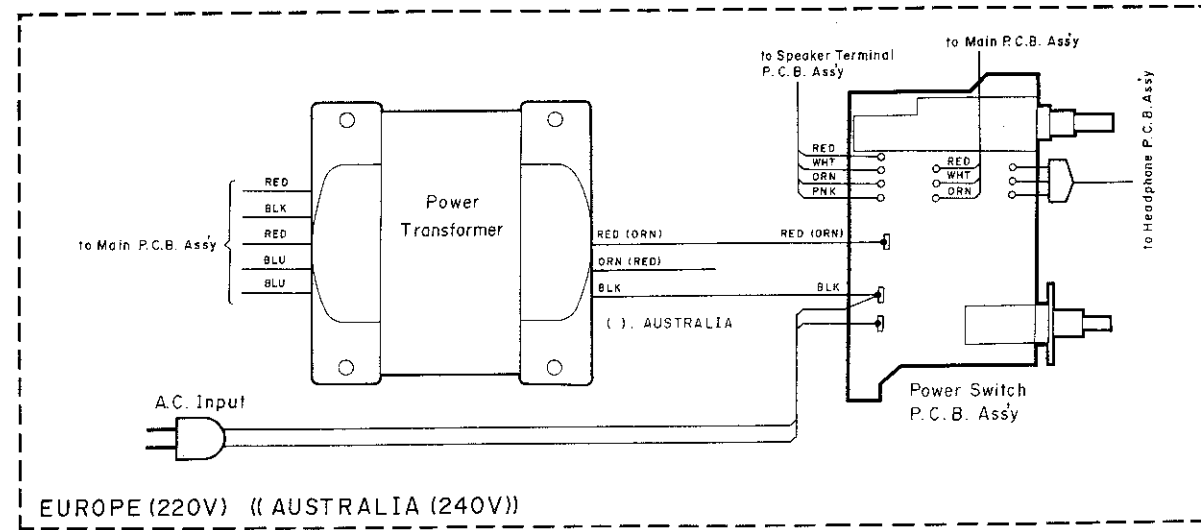

Fig. 7.2.2.

WARNING:
 Parts marked with the symbol  have critical characteristics.
 Use **ONLY** replacement parts recommended by the manufacturer.
 It is recommended that the unit be operated from a suitable DC supply or batteries during initial check-out procedures.

8. WIRING DIAGRAM



- Notes: 1. Table of wire colors
 BRN — Brown BLU — Blue
 RED — Red VIO — Violet
 ORN — Orange GRY — Gray
 YEL — Yellow WHT — White
 GRN — Green BLK — Black
2. Component side view of the P.C.B. is illustrated unless otherwise specified.
3. Wire tube color is shown in ().

Fig. 8

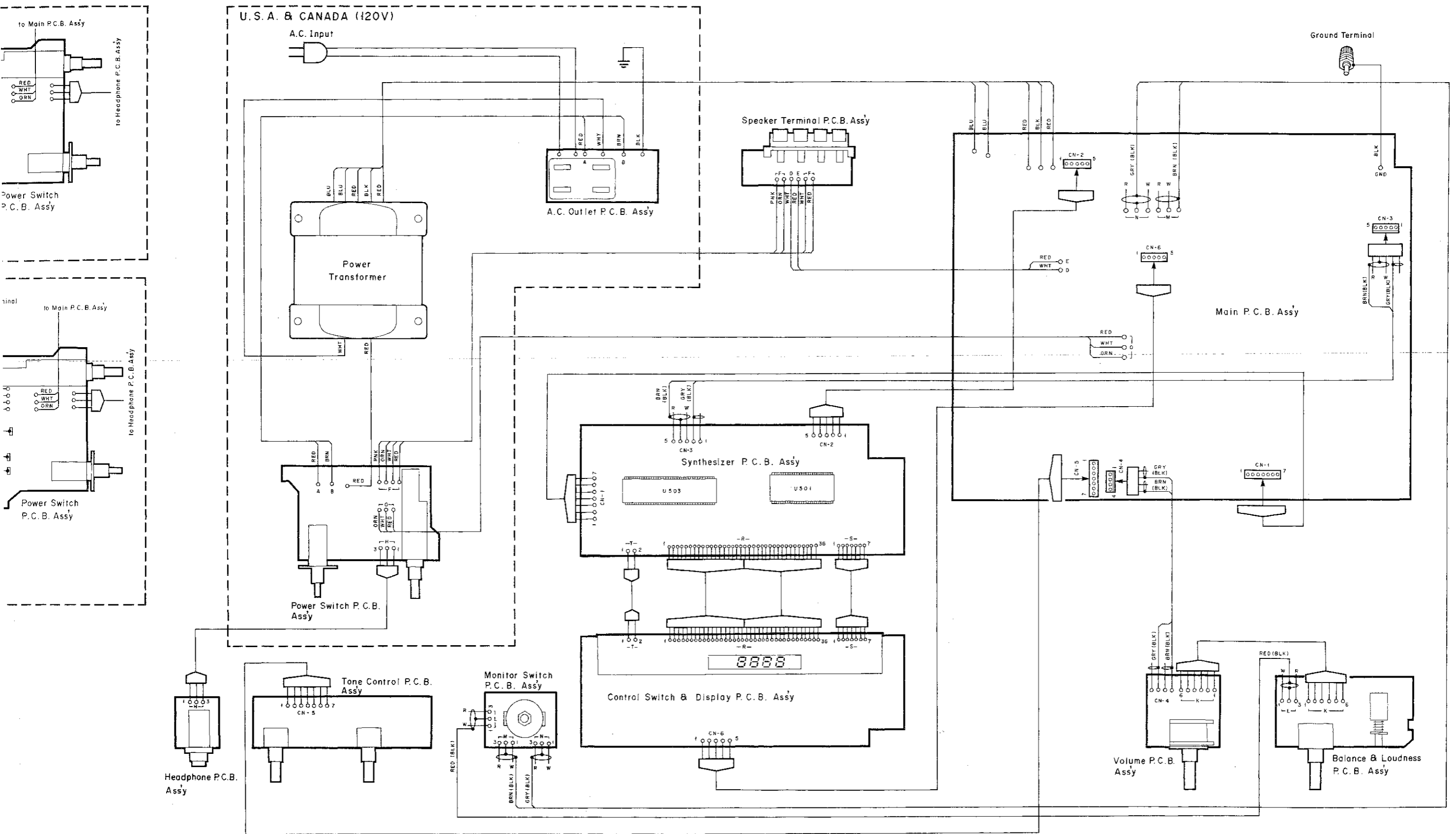

Fig. 8

9. BLOCK DIAGRAMS

9.1. Tuner Section

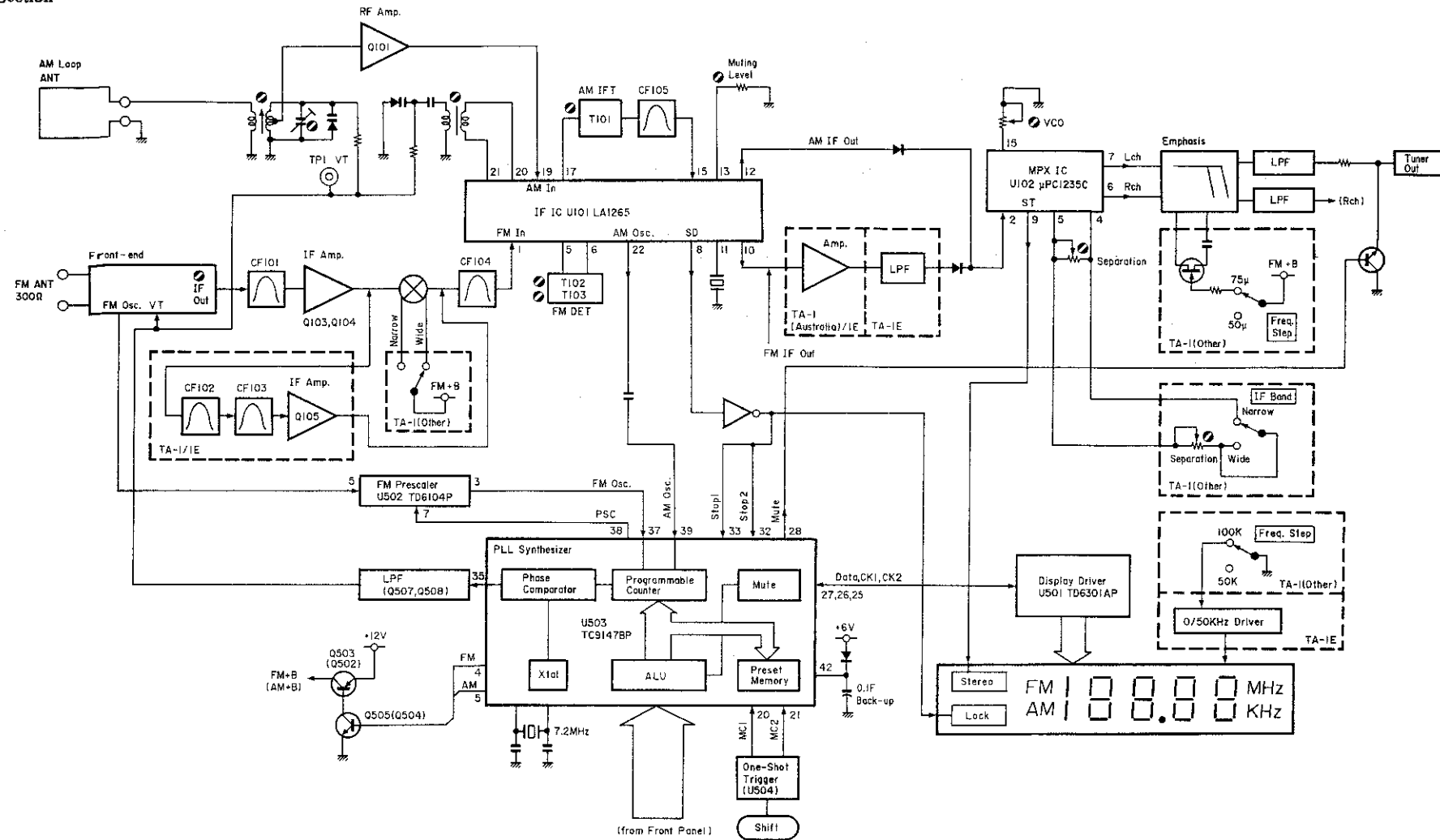

Fig. 9.1

9.2. Amplifier Section

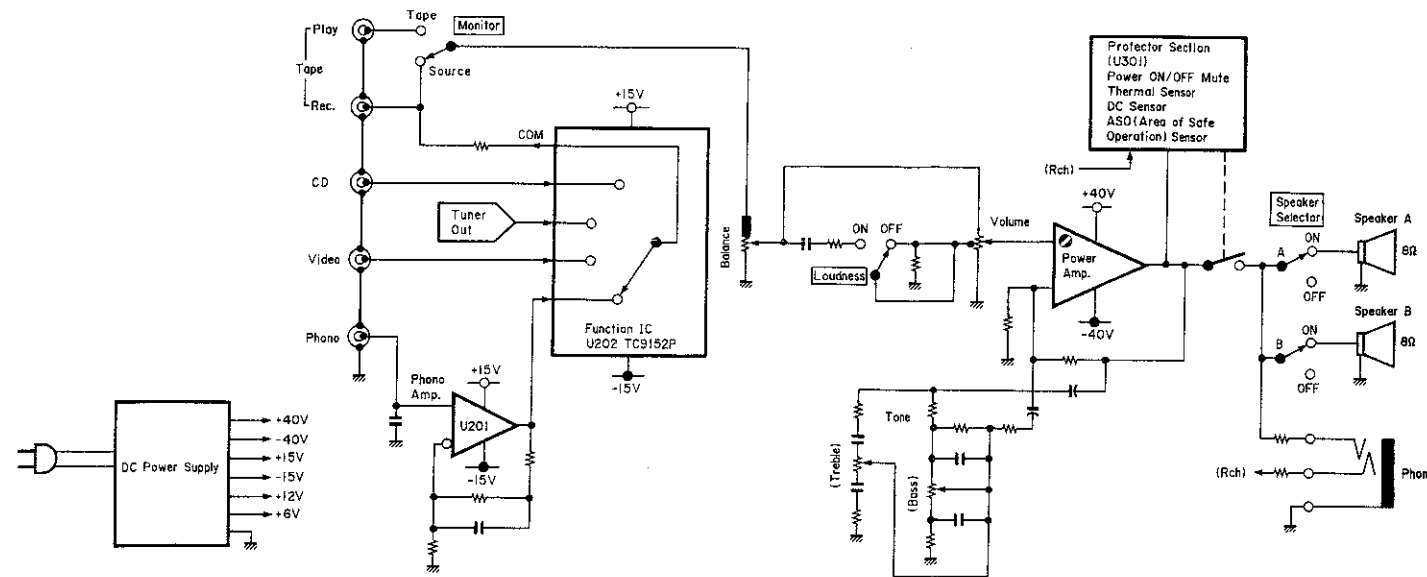

Fig. 9.2

10. SPECIFICATIONS

Power Amplifier Section

Note: Unless noted otherwise, specifications are in accordance with IHF-A-202 measured from any high-level input (CD/VIDEO/TAPE) to the speaker output.

Continuous Average Output Power	35 watts per channel into 8 ohms, both channels driven, 20–20,000 Hz, at no greater than 0.1% THD
Dynamic Output Power	52 watts per channel into 8 ohms 65 watts per channel into 4 ohms
Dynamic Head Room (8 ohms)	1.7 dB
Power Bandwidth	10–40,000 Hz
Frequency Response	20–20,000 Hz; ±1 dB 10–50,000; +0, -3 dB
Signal to Noise Ratio (A-WTD, Input Shorted)	Better than 98 dB re Rated Power Better than 84 dB (IHF-A-202)
Total Harmonic Distortion (8 ohms, Rated Power, 20 Hz–20 kHz)	Less than 0.1%
Headphone Rated Output (40 ohms)	82 mW
Output Current Capability	10 A peak per channel

Preamplifier Section

Note: Unless noted otherwise, specifications are in accordance with IHF-A-202. Except for Sensitivity, S/N, Tone Control and Loudness characteristics (which are measured to the speaker outputs), measurements are made from the specified input to Rec. Out.

Sensitivity (for rated output)	
Phono MM	2.5 mV
CD/Tape	150 mV
Sensitivity (for 1-watt output, IHF-A-202)	
Phono MM	0.42 mV
CD/Tape	25 mV
Input Impedance	
Phono MM	47 kohms
CD/Tape	20 kohms
Maximum Input Level (1 kHz)	
Phono MM	150 mV
Record Output Level/ Impedance	150 mV/2.2 kohms
Total Harmonic Distortion (1 kHz, to Rec. Out, at 1 V)	
Phono MM	Less than 0.01%
RIAA Deviation	
Phono MM	30–20,000 Hz ±1 dB
Signal to Noise Ratio (to speaker output, IHF-A-202)	
Phono MM	Better than 78 dB
Tone Controls	
Bass	20 Hz, ±10 dB
Treble	20 kHz, ±10 dB
Loudness (Volume: -30 dB)	20 Hz, +10 dB; 20 kHz, +6 dB

Tuner Section

(1) TA-1 (Other) (See Note) & TA-1A

Note: Selector switch settings for Other Model

Frequency Step FM/AM: 100 kHz/10 kHz, De-emphasis: 75 μs, IF Band: Wide

[FM Section]

Note: All RF levels in microvolts given re 300-ohm antenna input.

Modulation: Mono 100%, Stereo Pilot 9%, Stereo Audio Signal 91%.

All measurements made at Rec. Out Jack.

Frequency Range	87.5–108.0 MHz in 100 kHz steps
IHF Usable Sensitivity (Mono)	12.0 dBf/2.2 μV
50-dB Quieting Sensitivity	
Mono	15.7 dBf/3.3 μV
Stereo	38.5 dBf/46.1 μV
Signal to Noise Ratio at 65 dBf	
Mono	Better than 79 dB
Stereo	Better than 74 dB (TA-1A)/72 dB (TA-1 (Other))
Muting Threshold	30 dBf/17.3 μV
Frequency Response	30–15,000 Hz ±1.5 dB
Total Harmonic Distortion (1 kHz)	
Mono	Less than 0.15%
Stereo	Less than 0.20%
Capture Ratio	2.0 dB
Alternate Channel Selectivity	55 dB (±400 kHz)
Stereo Separation at 1 kHz	Better than 45 dB
Spurious Response Rejection	Better than 80 dB
Image Rejection	Better than 47 dB
IF Rejection	Better than 80 dB
AM Suppression	Better than 60 dB

[AM Section]

Note: Modulation — 400 Hz, 30%

Frequency Range	520–1,710 kHz in 10 kHz steps
Sensitivity	53 dBμ/m
Signal to Noise Ratio at 90 dBμ/m	Better than 52 dB
Total Harmonic Distortion at 90 dBμ/m	Less than 0.5%
Selectivity	Better than 20 dB (±10 kHz)

(2) TA-1 (Other) (See Note) & TA-1E

Note: Selector switch settings for Other Model

Frequency Step FM/AM: 50 kHz/9 kHz, De-emphasis: 50 μ s, IF Band: Narrow

[FM Section]

Note: All RF levels in microvolts given re 300-ohm antenna input.

Modulation: Mono 60%, Stereo Pilot 9%, Stereo Audio Signal 51%.

All measurements made at Rec. Out Jack.

Frequency Range	87.50—108.00 MHz in 50 kHz steps
IHF Usable Sensitivity (Mono)	12.0 dBf/2.2 μ V
50-dB Quieting Sensitivity	
Mono	15.7 dBf/3.3 μ V (TA-1E), 24.0 dBf/8.7 μ V (TA-1 (Other)),
Stereo	38.5 dBf/46.1 μ V (TA-1E), 44.0 dBf/86.8 μ V (TA-1 (Other)),
Signal to Noise Ratio at 65 dBf	
Mono	Better than 71 dB (TA-1E)/72 dB (TA-1 (Other))
Stereo	Better than 66 dB (TA-1E)/67 dB (TA-1 (Other))
Muting Threshold	30 dBf/17.3 μ V
Frequency Response	30—15,000 Hz \pm 1.5 dB
Total Harmonic Distortion (1 kHz)	
Mono	Less than 0.25% (TA-1E)/0.20% (TA-1 (Other))
Stereo	Less than 0.25%
Capture Ratio	2.0 dB
Alternate Channel Selectivity	70 dB (\pm 300 kHz)
Stereo Separation at 1 kHz	Better than 38 dB (TA-1E)/43 dB (TA-1 (Other))
Spurious Response Rejection	Better than 90 dB (TA-1E)/80 dB (TA-1 (Other))
Image Rejection	Better than 75 dB (TA-1E)/47 dB (TA-1 (Other))
IF Rejection	Better than 80 dB
AM Suppression	Better than 60 dB

[AM Section]

Note: Modulation — 400 Hz, 30%

Frequency Range	522—1,611 kHz in 9 kHz steps
Sensitivity	53 dB μ /m
Signal to Noise Ratio at 90	Better than 52 dB
dB μ /m	
Total Harmonic Distortion	Less than 0.5%
at 90 dB μ /m	
Selectivity	Better than 20 dB (\pm 9 kHz)

General

Power Source	120, 220, 240 or 110/120/220/240 V AC, 50/60 Hz (According to country of sale)
Power Consumption	220 watts max.
Convenience Outlets	Switched: 2 (For TA-1 (Other) & TA-1A)
Dimensions	430 (W) x 100 (H) x 265 (D) mm 16-15/16 (W) x 3-15/16 (H) x 10-7/16 (D) inches
Approximate Weight	6.0 kg, 13 lbs. 4 oz.

- Specifications and design are subject to change for further improvement without notice.