



Service Manual

Nakamichi

PA-7_{II}

PA-7A_{II}

PA-7E_{II}

Power Amplifier

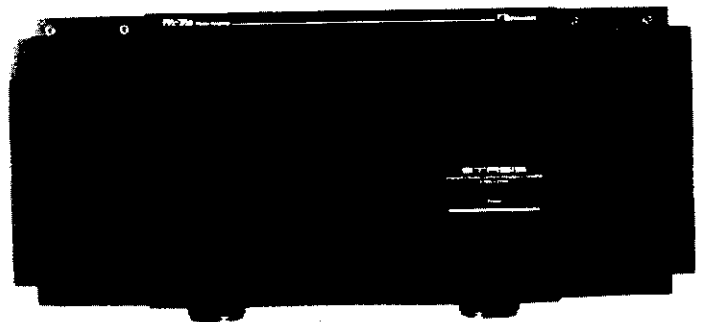

CONTENTS

1.	General	1
2.	Removal Procedures	2
2. 1.	Top Cover Ass'y	2
2. 2.	Heat Sink L (R) Ass'y and Amp. L (R) P.C.B. Ass'y	3
2. 3.	Front Panel Ass'y and Limiter P.C.B. Ass'y	3
2. 4.	Bottom Cover Ass'y and Power Supply P.C.B. Ass'y	3
3.	Parts Location for Electrical Adjustment	4
4.	Electrical Adjustments	4
4. 1.	Preparation for Adjustment	4
4. 2.	Idling Current Adjustment	4
4. 3.	DC Offset Check	4
5.	Mechanism Ass'y and Parts List	5
5. 1.	Synthesis	6
5. 2.	Handle L Ass'y (A01)	6
5. 3.	Handle R Ass'y (A02)	6
5. 4.	Front Panel Ass'y (A03)	6
5. 5.	Heat Sink L Ass'y (A04)	7
5. 6.	Heat Sink R Ass'y (A05)	7
5. 7.	Rear Panel Ass'y (A06)	8
6.	Mounting Diagrams and Parts List	9
6. 1.	Power LED P.C.B. Ass'y	9
6. 2.	Power Supply P.C.B. Ass'y	9
6. 3.	Limiter P.C.B. Ass'y	10
6. 4.	Thermister L P.C.B. Ass'y	10
6. 5.	Thermister R P.C.B. Ass'y	10
6. 6.	Amp. L P.C.B. Ass'y	12
6. 7.	Amp. R P.C.B. Ass'y	12
7.	Schematic Diagram	13
8.	Wiring Diagram	15
9.	Block Diagram	17
10.	Specifications	18

1. GENERAL

1.1. Voltage Selector

Voltage selector is installed on the rear panel for Other version of the Nakamichi PA-7II.
This voltage selector can select 110 V, 120 V, 220 V or 240 V at customer's disposal.

1.2. Package Ass'y and Accessory Ass'y

Schematic Ref. No.	Part No.	Description	Q'ty	Schematic Ref. No.	Part No.	Description	Q'ty
	—	Package Ass'y			OM04781A	Fuse Sheet 7A (PA-7II (Other))	1
01	OF04166B	Packing R	1		OB90203A	Fuse 10A 250V (PA-7II (Saudi Arabia))	2
02	OF04165B	Packing F	1		OM05186A	Fuse Sheet T6.3A (PA-7II (Saudi Arabia))	1
03	OF03879B	Poly-Bag for Set	1		OD03092B	Poly-Bag for Accessory	1
04	OF04169B	Carton Box (PA-7II)	1		OD04212A	Poly-Bag for Fuse	1
	OF04167B	Carton Box (PA-7AII)	1		OD04449A	Important Notice	1
	OF04168B	Carton Box (PA-7EII)	1		OD04876B	Owner's Manual (English/German/French)	1
—	OM03457A	Voltage Label 240V (PA-7II (Australia) & PA-7EII (UK))	1		OD04797C	Warranty Card (PA-7AII)	1
	—	Accessory Ass'y	1		OD04766B	General Catalogue (PA-7AII)	1
	OB90229A	Power Cord (PA-7II (Saudi Arabia))	1		OD04877A	Tape Catalogue (PA-7AII)	1
	OB80200A	Power Cord (PA-7AII (U.S.A.))	1		OD04893A	Speaker Supplement (PA-7EII)	1
	OF03887A	Power Cord Band (PA-7II (Saudi Arabia))	1				
	OM03844B	Power Cord Label (PA-7EII (UK))	1				
	OB90324A	Fuse T6.3A (PA-7II (Australia & Saudi Arabia) & PA-7EII)	1				
	OB90118A	Fuse 10A (PA-7II (Other))	2				
	OB90118A	Fuse 10A (PA-7AII)	1				
	OB90188A	Fuse 7A (PA-7II (Other))	1				
	OM04780A	Fuse Sheet 10A (PA-7II (Other & Saudi Arabia))	1				

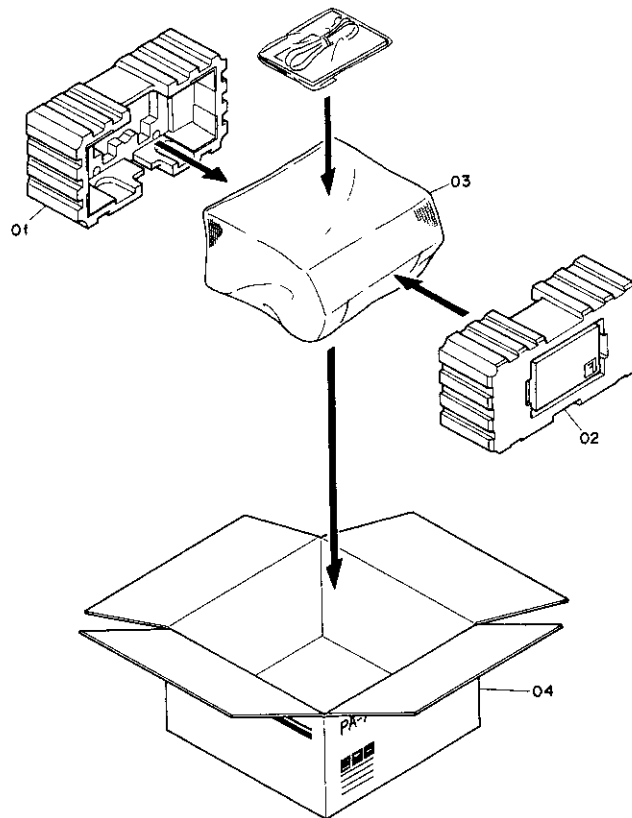

Fig. 1

2. REMOVAL PROCEDURES

2.1. Top Cover Ass'y

Refer to Fig. 2.1.

- (1) Loosen F01 (Bolt M4x10 Hex. Socket Head, 7 pcs.) with a hex. wrench and remove F02 (Top Cover Ass'y).

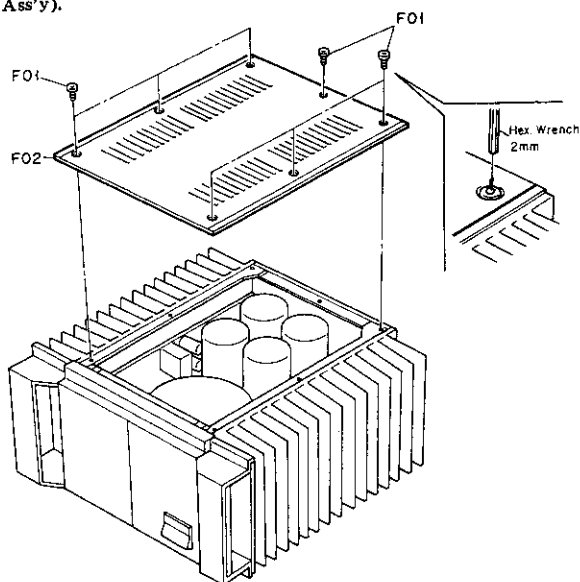

Fig. 2.1

2.2. Heat Sink L (R) Ass'y and Amp. L (R) P.C.B. Ass'y
Refer to Figs. 2.2.1 and 2.2.2.

- (1) Remove the Top Cover Ass'y referring to item 2.1.
- (2) Unsolder a wire F01 and pull out a connector F02.
- (3) Loosen screws F03 (7 pcs.) and F04, and remove F05 (Heat Sink R Ass'y).
- (4) Unsolder a wire F06 and pull out a connector F07.
- (5) Loosen screws F08 (7 pcs.) and F09, and remove F10 (Heat Sink L Ass'y).
- (6) Place F05 (Heat Sink R Ass'y) as shown in Fig. 2.2.2.
- (7) Loosen screws F11 (18 pcs.) and F12 (4 pcs.), and remove F13 (Amp. R P.C.B. Ass'y).
- (8) Separate F10 (Heat Sink L Ass'y) and remove the Amp. L P.C.B. Ass'y by applying the same removal procedures as for Amp. R P.C.B. Ass'y.

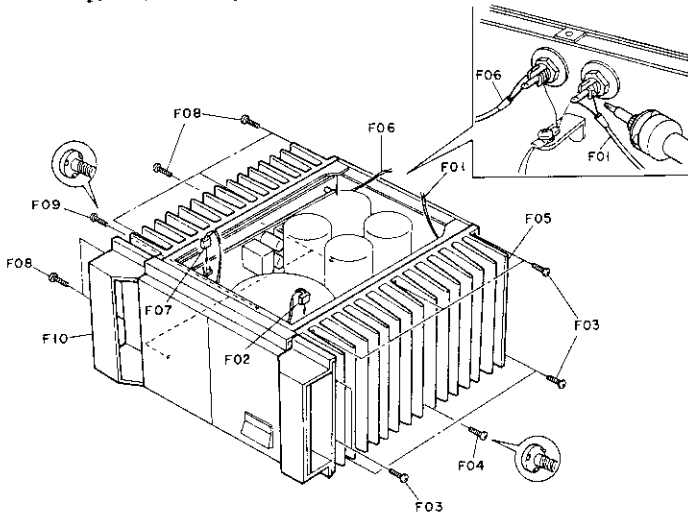

Fig. 2.2.1

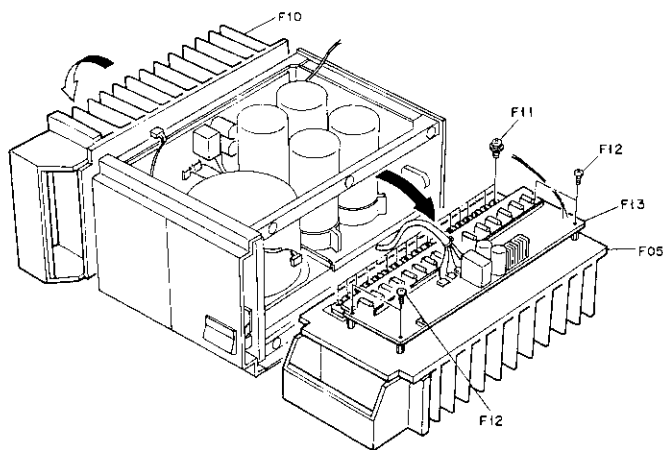

Fig. 2.2.2

2.3. Front Panel Ass'y and Limiter P.C.B. Ass'y
Refer to Fig. 2.3.

- (1) Remove the Top Cover Ass'y referring to item 2.1.
- (2) Loosen screws F01 (2 pcs.) and F02 (3 pcs.).
- (3) Pull out a connector F03 and remove F04 (Front Panel Ass'y).
- (4) Loosen screws F05 (4 pcs.).
- (5) Pull out connectors F06 and F07, and remove F08 (Limiter P.C.B. Ass'y).

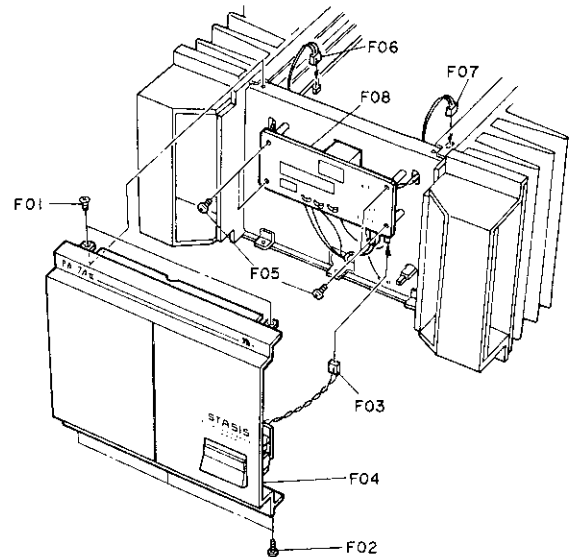

Fig. 2.3

2.4. Bottom Cover Ass'y and Power Supply P.C.B. Ass'y
Refer to Fig. 2.4.

- (1) Loosen F01 (14 pcs.) and F02 (3 pcs.), and remove F03 (Bottom Cover Ass'y).
- (2) Loosen F04, unsolder leads of capacitors from F05 (Ground Plate, 2 pcs.).
- (3) Lift F06 (Power Supply P.C.B. Ass'y).

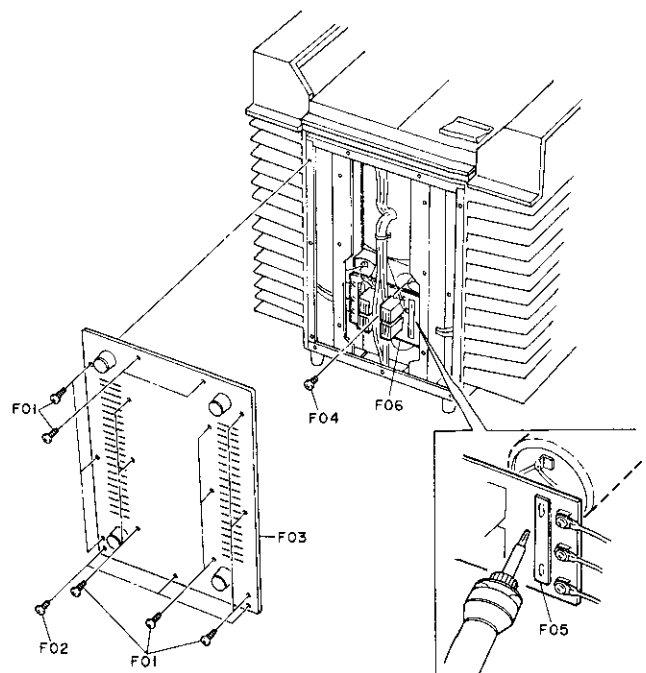

Fig. 2.4

3. PARTS LOCATION FOR ELECTRICAL ADJUSTMENT

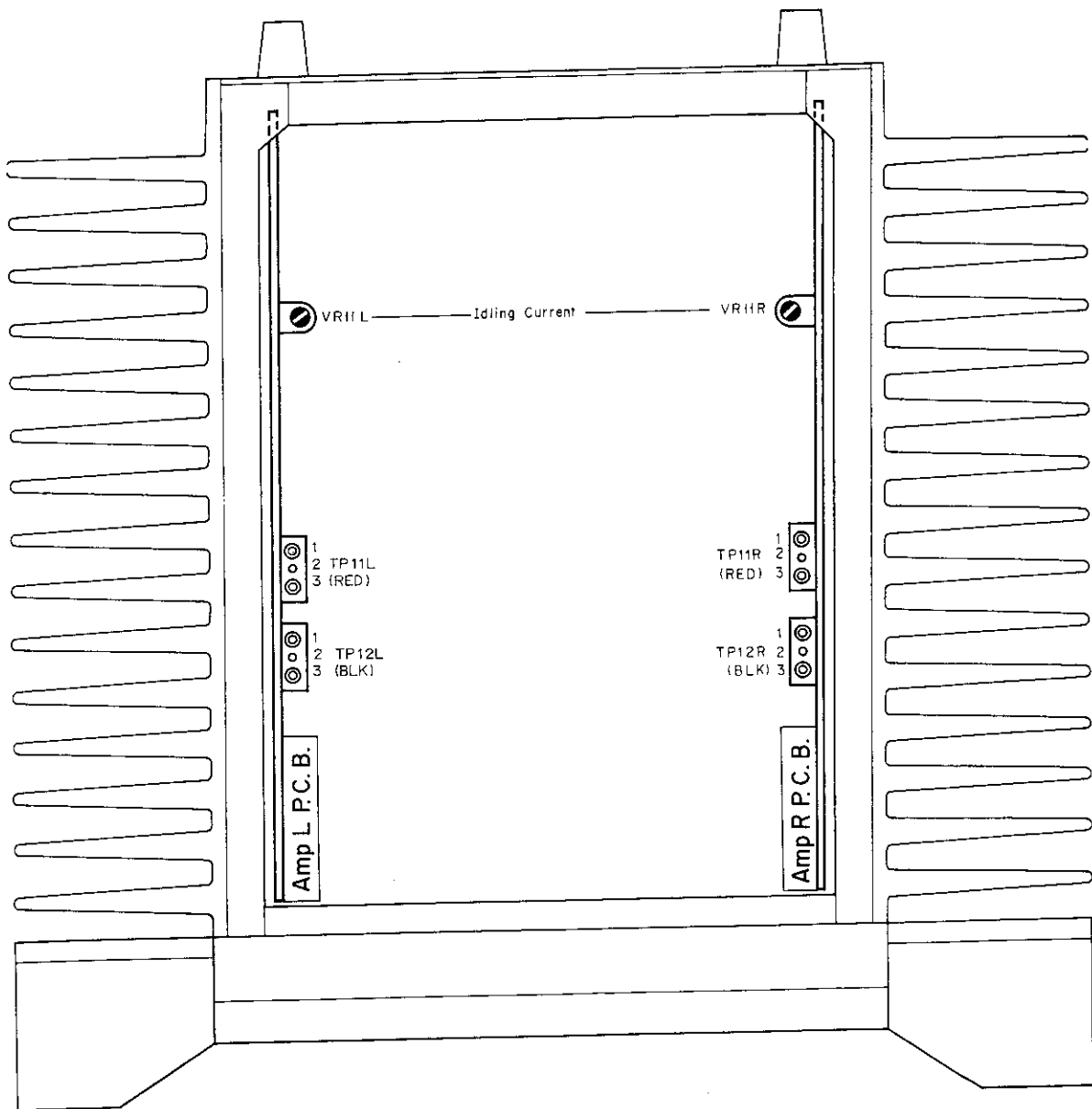

Fig. 3

4. ELECTRICAL ADJUSTMENTS

4.1. Preparation for Adjustment

- (1) Insert shorting pins into the Input Jacks.
- (2) Remove loads of the speaker terminals.
- (3) Before starting adjustment, allow twenty minutes or more after power is turned ON.

4.2. Idling Current Adjustment

- (1) Connect a DC voltmeter between pins 1 and 3 of TP11L (TP11R) on the Amp. L (R) P.C.B. Ass'y.
- (2) Adjust VR11L (VR11R) to obtain 40 mV on the DC voltmeter (idling current: 40 mA).

4.3. DC Offset Check

- (1) Connect a DC voltmeter between pins 1 and 3 of TP12L (TP12R) on the Amp. L (R) P.C.B. Ass'y.
- (2) Check whether the DC voltmeter reads 0 ± 50 mV.
- (3) Remove the shorting pins from the Input Jacks.

5. MECHANISM ASS'Y AND PARTS LIST

Schematic Ref. No.	Part No.	Description	Qty	Schematic Ref. No.	Part No.	Description	Qty
5.1. Synthesis				L02	0E03073A	BT 3x4 @ Countersunk (Black Chromate)	2
		Synthesis		L03	0E00921A	BT 3x8 @ Binding (Black Chromate)	34
01	HA04832A	Handle L Ass'y	1	L04	0E03366A	BT 3x8 @ Projected (Black Chromate)	12
02	HA04833A	Handle R Ass'y	1	L05	0E00875A	ST 3x6 @ Binding (Black Chromate)	4
03	HA05430A	Front Panel Ass'y (PA-7II)	1	L06	0E00510A	M3x8 @ Pan (2A)	2
	HA05429A	Front Panel Ass'y (PA-7AII)	1	L07	0E03498A	BT 3x12 @ Tapping (Black Chromate)	4
	HA05431A	Front Panel Ass'y (PA-7EII)	1	L08	0E00985A	M3x6 @ Binding (Black Chromate) (PA-7II (Australia), PA-7AII & PA-7EII)	3
04	BA07264A	Limiting P.C.B. Ass'y (PA-7II (Australia & Saudi Arabia) & PA-7EII)	1	0E00985A	M3x6 @ Binding (Black Chromate) (PA-7II (Other & Saudi Arabia))	5	
	BA07263A	Limiting P.C.B. Ass'y (PA-7II (Other) & PA-7AII)	1	L09	0E00988A	M4x12 @ Binding (Black Chromate)	14
05	OJ05757A	Bushing C	1	L10	0E03492A	M4x4 @ Binding (Nickel)	22
06	OJ05591B	Front Chassis	1	L11	0E03431A	Bolt M4x8 Hex. Socket Head (Black Chromate)	7
07	OB71003A	Power Switch	1	L12	0J05690A	Earth Plate	1
08	OM04676A	Fuse Caution Label (PA-7II (Other) & PA-7AII)	1	L13	0E03058A	M4x8 @ Binding (Black Chromate)	8
09	OH05306B	Bottom Cover	1	L14	0E03296A	M4x4 @ Binding (Black Chromate)	12
10	OJ05009A	Leg T-D	4	L15	0E00970A	M3x4 @ Binding (Black Chromate)	2
11	OJ05668A	Side Cushion B	2	L16	0E00940A	M3x6 @ Countersunk (Black Chromate)	2
12	OJ05666A	Side Cushion A	2	L17	0E03012A	BT 3x12 @ Binding (Black Chromate) (PA-7II (Australia & Other), PA-7AII (Canada) & PA-7EII)	2
13	—	Heat Sink L Ass'y	1	L18	0E03493A	M4x12 @ Binding Projected (Black Chromate)	2
14	—	Heat Sink R Ass'y	1	L19	0E03028A	BT 3x8 @ Binding (Nickel)	1
15	OJ05587A	Side Frame L	2	—	OM03797A	Voltage Seal 240V (PA-7EII (UK))	1
16	OJ05588A	Side Frame R	2	—	OM03844B	Power Cord Label (PA-7EII (UK))	1
17	OB83339A	GND Cord (BLK)	2	—	OM03917A	Production Date Seal (PA-7AII (U.S.A.))	1
18	OB83338A	DC Cord (+) (RED) (PA-7II, PA-7AII (U.S.A.) & PA-7EII)	2	—	OM05063A	EP Approval Label H (PA-7EII (Except for UK & Switzerland))	1
	OB83552A	DC Cord (+) (PA-7AII (Canada))	2	—	OM05064A	EP Approval Label I (PA-7EII (Switzerland))	1
19	OB83337A	DC Cord (-) (BLU) (PA-7II, PA-7AII (U.S.A.) & PA-7EII)	2	—	OM05185A	Thermal Fuse Caution (PA-7AII (Canada))	1
	OB83551A	DC Cord (-) (PA-7AII (Canada))	2	—	OM05188A	Fuse Caution Sheet (PA-7II (Saudi Arabia))	1
20	OJ05651A	Bushing B	2	—	OM05190A	Fuse Label 6.3A (PA-7II (Saudi Arabia))	1
21	OJ05592A	Center Frame L	1	—	OB80099A	Insulation Tube	6
22	OJ05593A	Center Frame R	1	5.2. Handle L Ass'y (A01)			
23	OM04377B	Caution Label (PA-7AII)	2	A01	HA04832A	Handle L Ass'y	1
24	HA05413A	Top Cover Ass'y	1	01	OH04631A	Handle L	1
25	OM05194A	Toroidal Transformer Label	1	02	OJ05006A	Vinyl Chloride Plate A	2
26	OB50112A	Power Transformer (PA-7II (Australia) & PA-7EII (UK))	1	03	OH04655A	Vinyl Chloride Plate B	1
	OB50110A	Power Transformer (PA-7II (Other & Saudi Arabia))	1	L01	0E03310A	M4x6 @ Binding (Black Chromate)	2
	OB50109A	Power Transformer (PA-7AII)	1	5.3. Handle R Ass'y (A02)			
	OB50111A	Power Transformer (PA-7EII (Except for UK))	1	A02	HA04833A	Handle R Ass'y	1
27	OB40500A	Electrolytic Capacitor 33000µF 100V	2	01	OH04632A	Handle R	1
28	OB40506A	Electrolytic Capacitor 33000µF 100V	2	02	OJ05006A	Vinyl Chloride Plate A	2
29	OJ05590B	Power Supply Chassis	1	03	OH04655A	Vinyl Chloride Plate B	1
30	OJ05647B	Insulator B	2	L01	0E03310A	M4x6 @ Binding (Black Chromate)	2
31	OJ05648B	Stud L5.5mm	1	5.4. Front Panel Ass'y (A03)			
32	BA07281A	Power Supply P.C.B. Ass'y	1	A03	HA05430A	Front Panel Ass'y (PA-7II)	1
33	OB83328A	Bridge Cord - (BLU)	2		HA05429A	Front Panel Ass'y (PA-7AII)	1
34	OB83327A	Bridge Cord + (RED)	2		HA05431A	Front Panel Ass'y (PA-7EII)	1
35	OB83343A	AC L Cord B	1	01	HA04849A	Power Switch Knob Ass'y	1
36	OB83342A	AC L Cord A	1	02	OJ05646B	Power Spring	1
37	OB83345A	AC N Cord	1	03	OH05309A	Front Panel (PA-7II)	1
38	OB83344A	AC L Cord C	1		OH05307A	Front Panel (PA-7AII)	1
39	HA05435A	Rear Panel Ass'y (PA-7II (Australia))	1		OH05308A	Front Panel (PA-7EII)	1
	HA05434A	Rear Panel Ass'y (PA-7II (Other))	1	04	OH04652B	Power Switch Guide	1
	HA05438A	Rear Panel Ass'y (PA-7II (Saudi Arabia))	1	05	OJ05307A	BS Damper	2
	HA05439A	Rear Panel Ass'y (PA-7AII (U.S.A.))	1	06	OH04653B	Power Lens	1
	HA05433A	Rear Panel Ass'y (PA-7AII (Canada))	1	07	OJ05010C	Sheet	1
	HA05432A	Rear Panel Ass'y (PA-7EII (UK))	1	08	OJ04998B	Power Switch Refractor	1
	HA05437A	Rear Panel Ass'y (PA-7EII (Except for UK & Switzerland))	1	09	BA07265A	Power LED P.C.B. Ass'y	1
	HA05436A	Rear Panel Ass'y (PA-7EII (Switzerland))	1	10	OJ05178A	BS Damper	1
40	OB70049A	Voltage Selector Switch (PA-7II (Other & Saudi Arabia))	1	L01	0E00868A	BT 3x8 @ Binding	3
41	OJ05694A	Insulator A (PA-7EII)	1		OJ05691A	Power Base Cushion	1
42	OB81937A	Terminal (PA-7II (Australia & Other), PA-7AII (Canada) & PA-7EII)	1		OJ05693A	Power Base Cushion A	1
43	OB08515A	Insu-Lock	14				
44	OM04778A	Fuse Caution Sheet (PA-7II (Other))	1				
45	OM04430A	Pass Label	1				
46	OM05182A	Serial No. Seal	1				
47	OM04113A	LA Label (PA-7AII (U.S.A.))	1				
48	OM03905A	UL Label Audio (PA-7AII (U.S.A.))	1				
L01	0E00745A	Bolt M4x10 Hex. Socket Head (Black Chromate)	8				

5.1. Synthesis

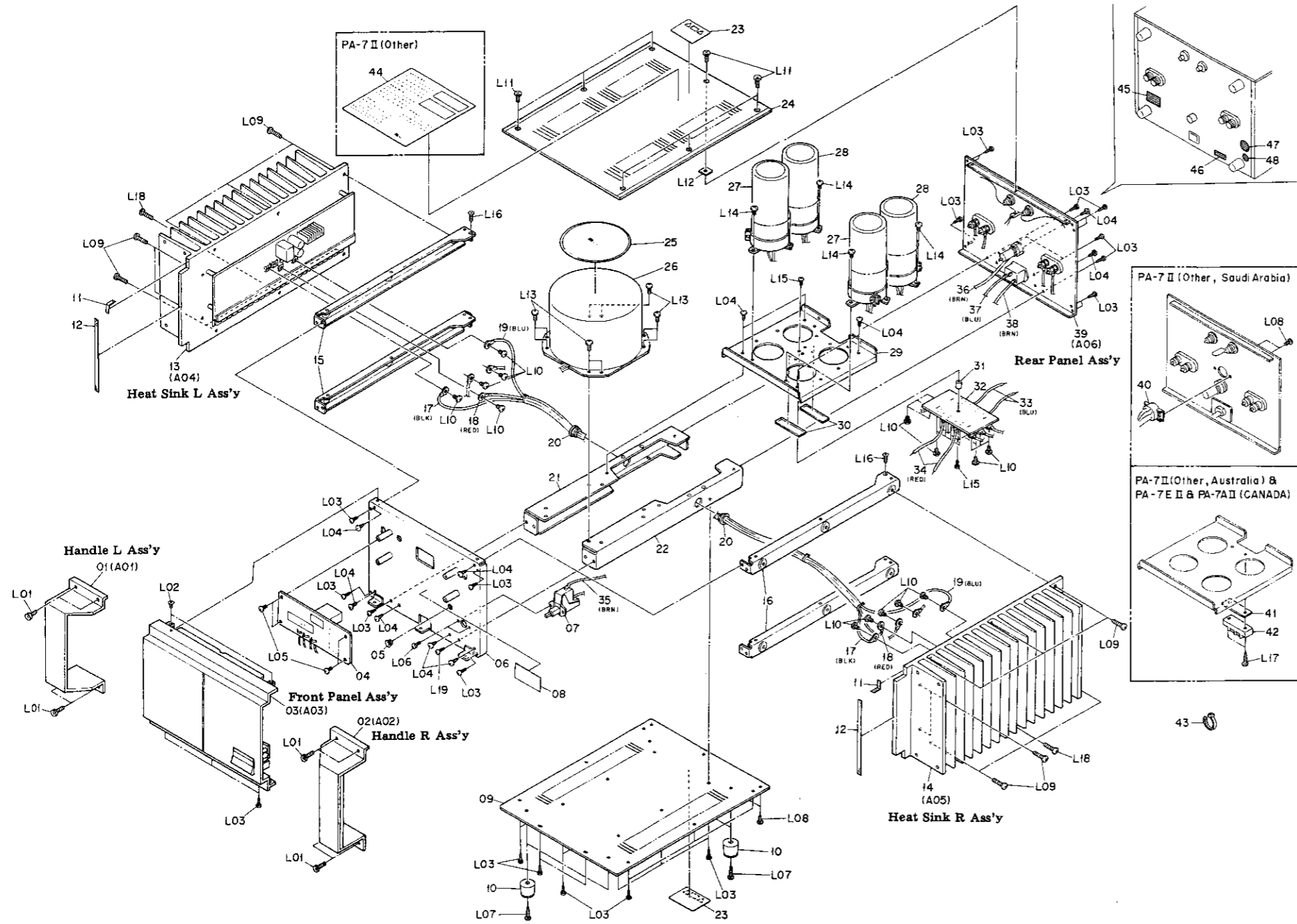

Fig. 5.1

5.2. Handle L Ass'y (A01)

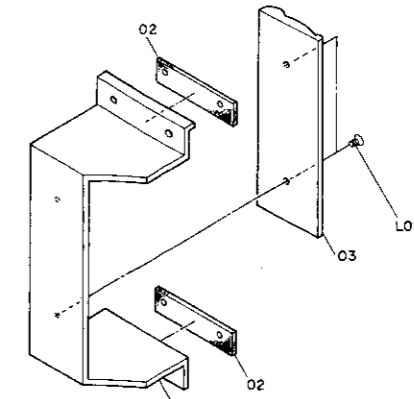

Fig. 5.2

5.3. Handle R Ass'y (A02)

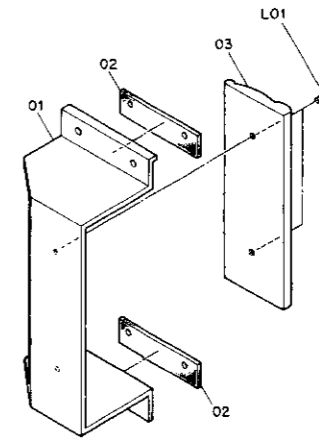

Fig. 5.3

5.4. Front Panel Ass'y (A03)

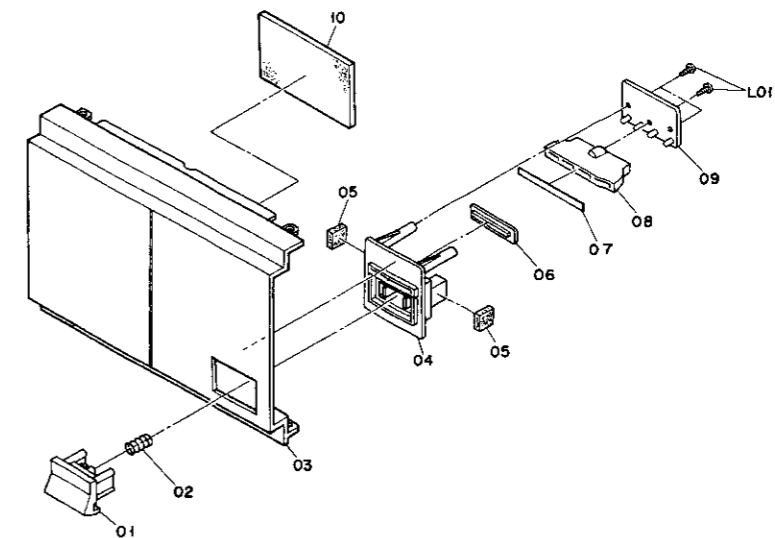

Fig. 5.4

5.5. Heat Sink L Ass'y (A04)

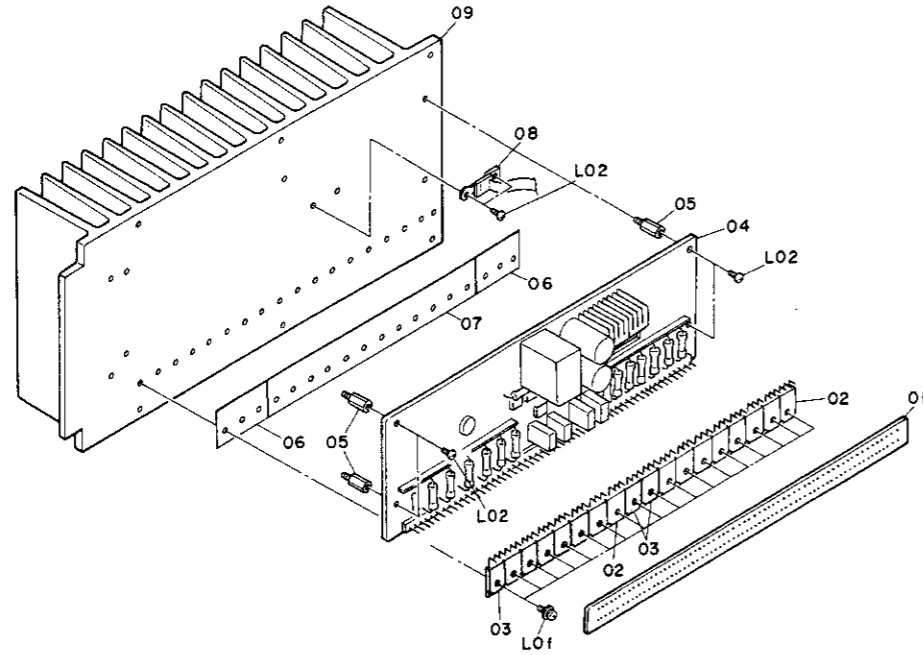

Fig. 5.5

5.6. Heat Sink R Ass'y (A05)

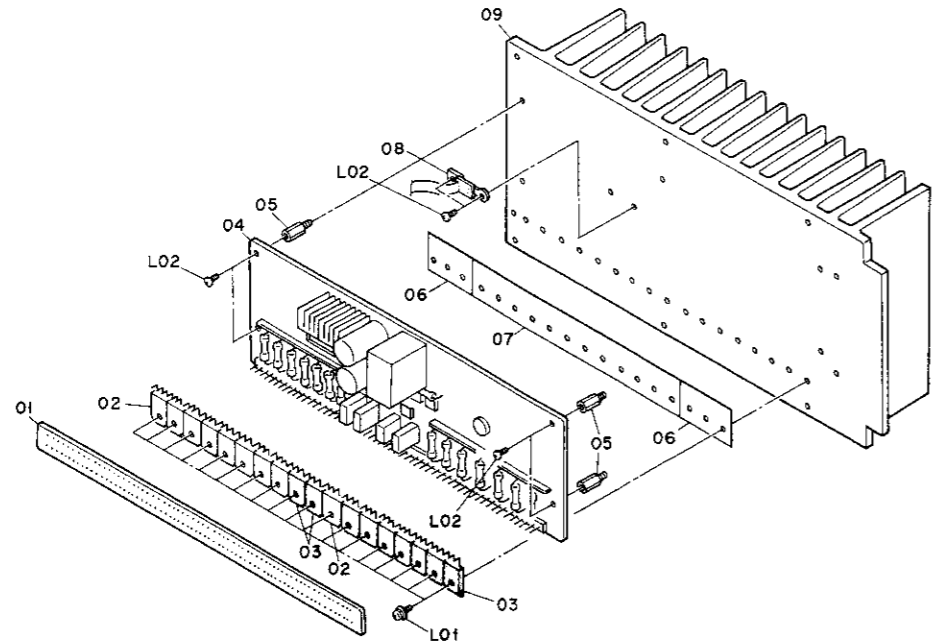

Fig. 5.6

Schematic Ref. No.	Part No.	Description	Q'ty	Schematic Ref. No.	Part No.	Description	Q'ty
5.5. Heat Sink L Ass'y (A04)							
A04	—	Heat Sink L Ass'y	1				
01	0B60572A	Power Transistor L P.C.B.	1	06	0B90093B	Fuse Holder (PA-7II (Other) & PA-7AII)	1
02	0B10250A	TR 2SC3856 [Q116L]	1	06	0B90324A	Fuse T6.3A (PA-7II (Australia & Saudi Arabia) & PA-7EII)	1
	0B10250A	TR 2SC3856 [Q118L]	1		0B90188A	Fuse 7A (PA-7II (Other))	1
	0B10250A	TR 2SC3856 [Q121L]	1	07	0B90118A	Fuse 10A (PA-7AII)	1
	0B10250A	TR 2SC3856 [Q123L]	1		0J05029A	Leg (PA-7II & PA-7AII)	4
	0B10250A	TR 2SC3856 [Q125L]	1		0H05447A	Leg (PA-7EII)	4
	0B10250A	TR 2SC3856 [Q127L]	1	08	0H05297C	Rear Panel (PA-7II (Australia))	1
	0B10250A	TR 2SC3856 [Q129L]	1		0H05296C	Rear Panel (PA-7II (Other))	1
	0B10250A	TR 2SC3856 [Q131L]	1		0H05373B	Rear Panel (PA-7II (Saudi Arabia))	1
	0B10250A	TR 2SC3856 [Q133L]	1		0H05299C	Rear Panel (PA-7AII)	1
03	0B10251A	TR 2SA1492 [Q117L]	1		0H05298E	Rear Panel (PA-7EII)	1
	0B10251A	TR 2SA1492 [Q119L]	1	09	0B83335A	Speaker Cord Hot (YEL)	2
	0B10251A	TR 2SA1492 [Q120L]	1	10	0B83335A	Speaker Cord Hot (YEL) (PA-7II, PA-7AII (U.S.A.) & PA-7EII)	2
	0B10251A	TR 2SA1492 [Q122L]	1		0B83550A	Speaker Cord Hot (PA-7AII (Canada))	2
	0B10251A	TR 2SA1492 [Q124L]	1	11	0J05246A	Ground Bracket	1
	0B10251A	TR 2SA1492 [Q126L]	1	12	0B83334A	Input Ground Cord	1
	0B10251A	TR 2SA1492 [Q128L]	1	13	0B83326A	Chassis Ground Cord	1
	0B10251A	TR 2SA1492 [Q130L]	1	14	0B90087A	AC Inlet (PA-7II (Saudi Arabia))	1
	0B10251A	TR 2SA1492 [Q132L]	1	15	0B90092A	AC Inlet (PA-7AII (U.S.A.))	1
04	BA07259A	Amp. L P.C.B. Ass'y (PA-7II, PA-7AII (U.S.A.) & PA-7EII (Canada))	1		0B80101A	Ground Cable with Earth Lug (PA-7II (Saudi Arabia) & PA-7AII (U.S.A.))	1
	BA07446A	Amp. L P.C.B. Ass'y (PA-7AII (Canada))	1	16	0B80133B	Power Cord (PA-7II (Australia))	1
05	0J05595A	P.C.B. Stud	4		0B80085A	Power Cord (PA-7II (Other))	1
06	0J05600A	Cooling Sheet B	2		0B80131A	Power Cord (PA-7AII (Canada))	1
07	0J05601A	Cooling Sheet A	1		0B80134B	Power Cord (PA-7EII (UK))	1
08	BA07261A	Thermistor L P.C.B. Ass'y	1		0B80124A	Power Cord (PA-7EII (Except for UK & Switzerland))	1
09	0H05304A	Heat Sink L	1		0B80132B	Power Cord (PA-7EII (Switzerland))	1
L01	0E03490A	M3x10 @ Binding (3A) (Nickel)	18	17	0B90157A	Cord Bushing SR-6N-4 (PA-7II (Australia) & PA-7EII)	1
L02	0E00966A	M3x5 @ Binding (Nickel)	6		0B90186A	Cord Bushing SR-33-1 (PA-7II (Other))	1
5.6. Heat Sink R Ass'y (A05)							
A05	—	Heat Sink R Ass'y	1		0B02232A	Cord Bushing SR-6N3-4 (PA-7AII (Canada))	1
01	0B60573A	Power Transistor R P.C.B.	1	18	0H04772A	Bushing Holder (PA-7II (Australia), PA-7AII (Canada) & PA-7EII)	1
02	0B10250A	TR 2SC3856 [Q116R]	1		0H04856A	Bushing Holder (PA-7II (Other))	1
	0B10250A	TR 2SC3856 [Q118R]	1	19	0J05745A	Leg Felt (PA-7EII)	4
	0B10250A	TR 2SC3856 [Q121R]	1		0J05744A	Terminal Plate (PA-7EII)	4
	0B10250A	TR 2SC3856 [Q123R]	1	20	0B81982A	Speaker Terminal (+) (PA-7EII)	2
	0B10250A	TR 2SC3856 [Q125R]	1	21	0B81983A	Speaker Terminal (-) (PA-7EII)	2
	0B10250A	TR 2SC3856 [Q127R]	1	22	0E03486A	M4x8 @ Pan (Black Chromate) (PA-7II & PA-7AII)	4
	0B10250A	TR 2SC3856 [Q129R]	1	L01	0E00988A	M4x12 @ Binding (PA-7EII)	4
	0B10250A	TR 2SC3856 [Q131R]	1	L02	0E00594A	M3x8 @ Binding (Bronze)	1
	0B10250A	TR 2SC3856 [Q133R]	1	L03	0E03137A	M3x10 @ Binding (Black Chromate) (PA-7II (Saudi Arabia) & PA-7AII (U.S.A.))	2
03	0B10251A	TR 2SA1492 [Q117R]	1	L04	0E03058A	M4x8 @ Binding (Black Chromate) (PA-7II (Australia & Saudi Arabia), PA-7AII (U.S.A.) & PA-7EII (Switzerland))	1
	0B10251A	TR 2SA1492 [Q119R]	1	L05	0E03395A	M3x8 @ Binding (CU)	1
	0B10251A	TR 2SA1492 [Q120R]	1	L06	0E00507A	Hut Hex. M3 (PA-7II (Saudi Arabia) & PA-7AII (U.S.A.))	2
	0B10251A	TR 2SA1492 [Q122R]	1	L07	0E00078A	Washer 4mm Toothed Lock (PA-7II (Australia & Saudi Arabia), PA-7AII (U.S.A.) & PA-7EII (Switzerland))	1
	0B10251A	TR 2SA1492 [Q124R]	1	L08	0E00669A	Nut Hex. M4 (PA-7II (Australia & Saudi Arabia), PA-7AII (U.S.A.) & PA-7EII (Switzerland))	1
	0B10251A	TR 2SA1492 [Q126R]	1	L09	0E00921A	BT 3x8 @ Binding (Black Chromate) (PA-7II (Australia & Other), PA-7AII (Canada) & PA-7EII)	2
	0B10251A	TR 2SA1492 [Q128R]	1	L10	0J05689A	Rivet (PA-7II (Other), PA-7AII (Canada) & PA-7EII (UK & except for Switzerland))	1
	0B10251A	TR 2SA1492 [Q130R]	1	L11	0E03406A	Washer D3	2
	0B10251A	TR 2SA1492 [Q132R]	1	L12	0E03287A	M4x6 @ Binding Gold (PA-7EII)	4
04	BA07260A	Amp. R P.C.B. Ass'y (PA-7II, PA-7AII (U.S.A.) & PA-7EII (Canada))	1	—	0M03700A	Ground Mark Label (PA-7II (Australia & Saudi Arabia), PA-7AII (U.S.A.) & PA-7EII (Switzerland))	1
	BA07447A	Amp. R P.C.B. Ass'y (PA-7AII (Canada))	1	—	0M04779A	Fuse Caution Label (PA-7II (Other))	1
05	0J05595A	P.C.B. Stud	4	—	0M05191A	Fuse Caution Label (PA-7II (Saudi Arabia))	1
06	0J05600A	Cooling Sheet B	2	—	0B80099A	Insulation Tube	8
07	0J05601A	Cooling Sheet A	1				
08	BA07262A	Thermistor R P.C.B. Ass'y	1				
09	0H05305A	Heat Sink R	1				
L01	0E03490A	M3x10 @ Binding (3A) (Nickel)	18				
L02	0E00966A	M3x5 @ Binding (Nickel)	6				
5.7. Rear Panel Ass'y (A06)							
A06	HA05435A	Rear Panel Ass'y (PA-7II (Australia))	1				
	HA05434A	Rear Panel Ass'y (PA-7II (Other))	1				
	HA05438A	Rear Panel Ass'y (PA-7II (Saudi Arabia))	1				
	HA05439A	Rear Panel Ass'y (PA-7AII (U.S.A.))	1				
	HA05433A	Rear Panel Ass'y (PA-7AII (Canada))	1				
	HA05432A	Rear Panel Ass'y (PA-7EII (UK))	1				
	HA05437A	Rear Panel Ass'y (PA-7EII (Except for UK & Switzerland))	1				
	HA05436A	Rear Panel Ass'y (PA-7EII (Switzerland))	1				
01	0B83485A	Input Cord Ass'y	2				
02	0B81365A	Speaker Terminal	2				
03	0J05310A	BS Damper	1				
04	0B81364A	RCA Pin Jack	2				
05	0B90094B	Fuse Holder EP (PA-7II (Australia & Saudi Arabia) & PA-7EII)	1				

5.7. Rear Panel Ass'y (A06)

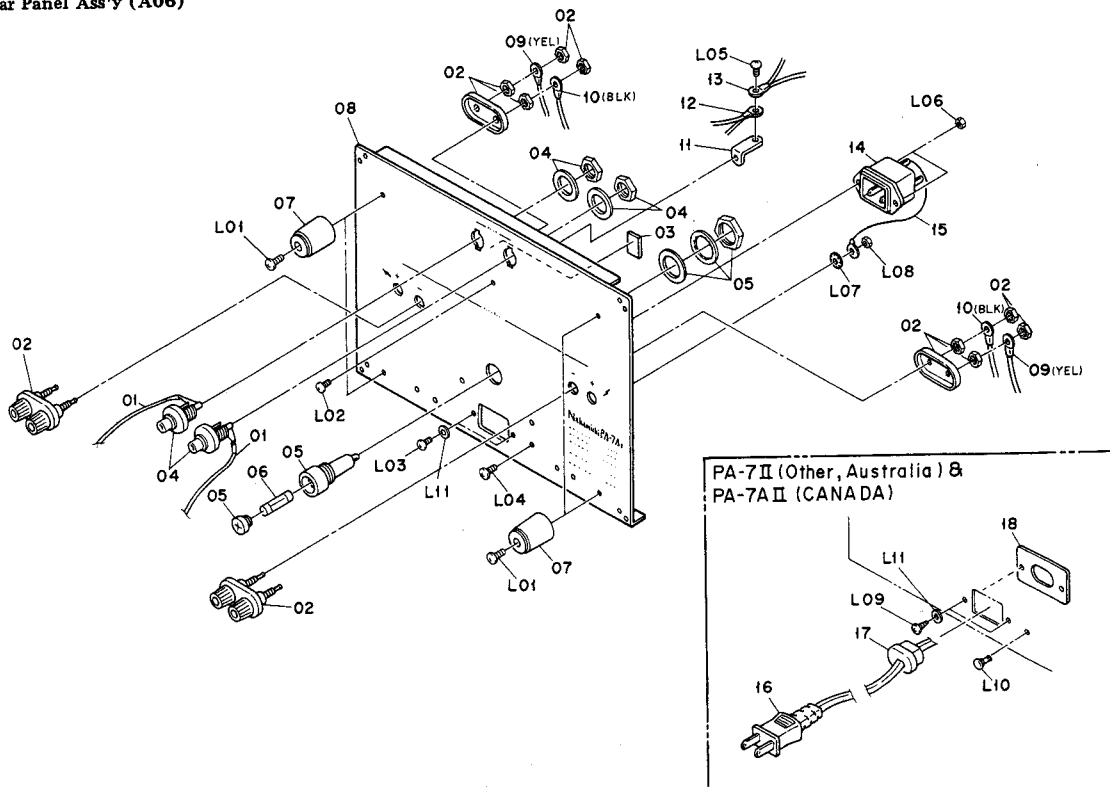

Fig. 5.7.1 PA-7II & PA-7AII

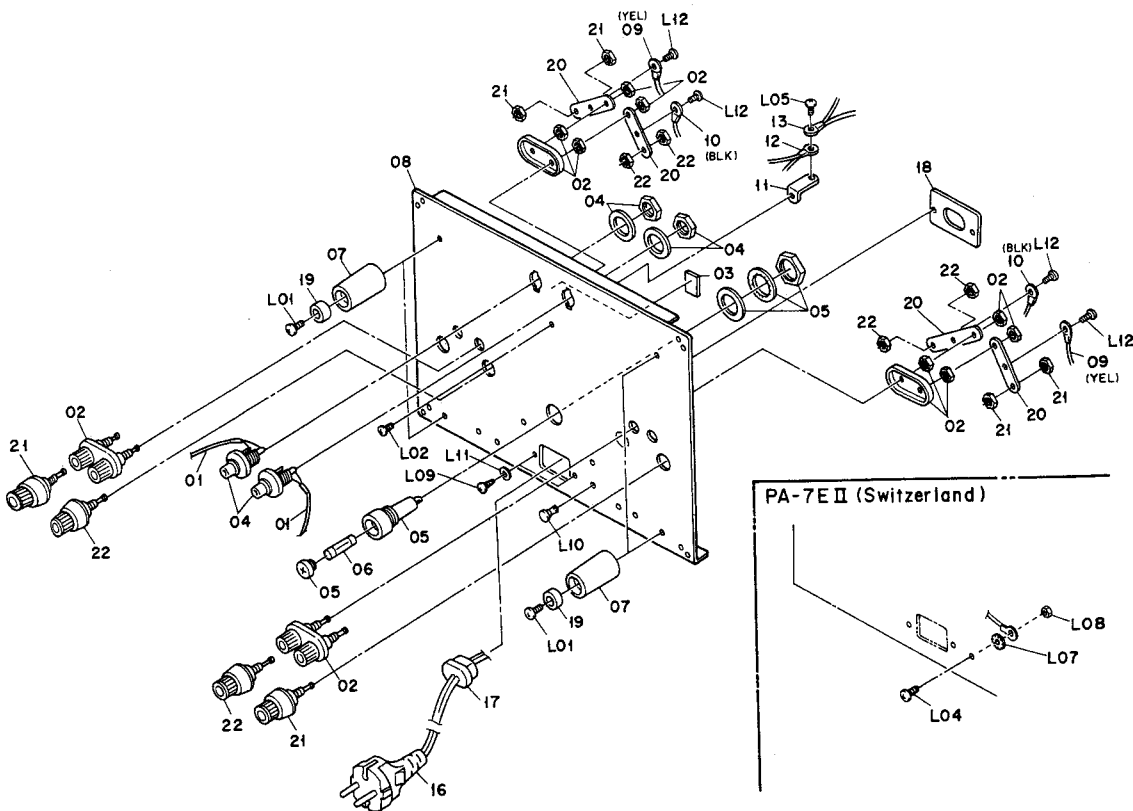

Fig. 5.7.2 PA-7EII

6. MOUNTING DIAGRAMS AND PARTS LIST

- Notes: 1. Mounting diagram shows a dip side view of the printed circuit board.
 2. Diode is 1SS176, 1SS53, or 1S1555 unless otherwise specified.
 3. Abbreviation for part name:

TR — Transistor, SiD — Silicon Diode, ZD — Zener Diode
 RK — Carbon Resistor, RM — Metal Film Resistor, RF — Fail Safe Type Resistor, RC — Cement Resistor
 CE — Electrolytic Capacitor, CML — Mylar Capacitor, CC — Ceramic Capacitor, CPP — PP Capacitor,
 CMM — Metalized Mylar Capacitor, CSP — Polystyrene Capacitor, C — Mica Capacitor

6.1. Power LED P.C.B. Ass'y

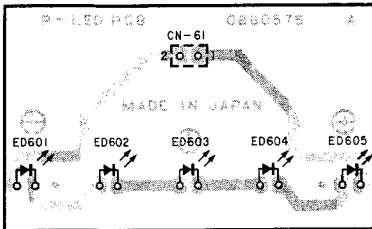

Fig. 6.1

6.2. Power Supply P.C.B. Ass'y

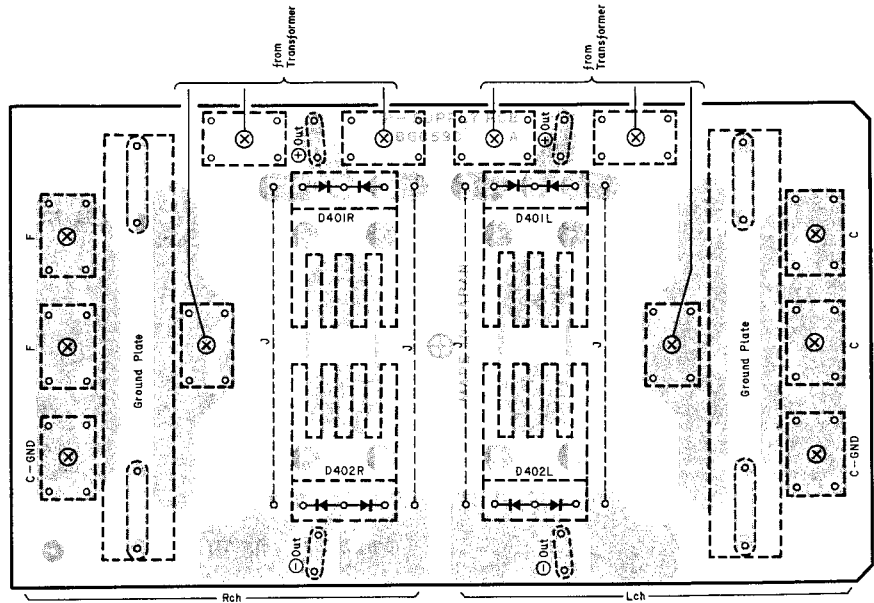

Fig. 6.2

Schematic Ref. No.	Part No.	Description	Schematic Ref. No.	Part No.	Description
6.1. Power LED P.C.B. Ass'y			6.2. Power Supply P.C.B. Ass'y		
	BA07265A	Power LED P.C.B. Ass'y		BA07281A	Power Supply P.C.B. Ass'y
ED601	0B60575A	Power LED P.C.B. LED SLR-34MG3F GRN	D401L	0B60590A	Power Supply P.C.B. SiD FMU-32S
ED602	0B12251B	LED SLR-34MG3F GRN	D401R	0B12611A	SiD FMU-32S
ED603	0B12251B	LED SLR-34MG3F GRN	D402L	0B12611A	SiD FMU-32R
ED604	0B12251B	LED SLR-34MG3F GRN	D402R	0B12612A	SiD FMU-32R
ED605	0B12251B	LED SLR-34MG3F GRN		0B12612A	SiD FMU-32R
CN61	0B83333A	P-LED Cord Ass'y		0B81933A	Screw Terminal P-436 (12)
				0E03395A	M3x8 @ Binding (CU) (4)
				0J05211A	Heat Sink (4)
				0J05629A	Ground Plate A (2)
				0B83346A	Bridge Cord AC (4)
				0B81938A	Tab Receptacle P-92 (4)

6.3. Limiter P.C.B. Ass'y

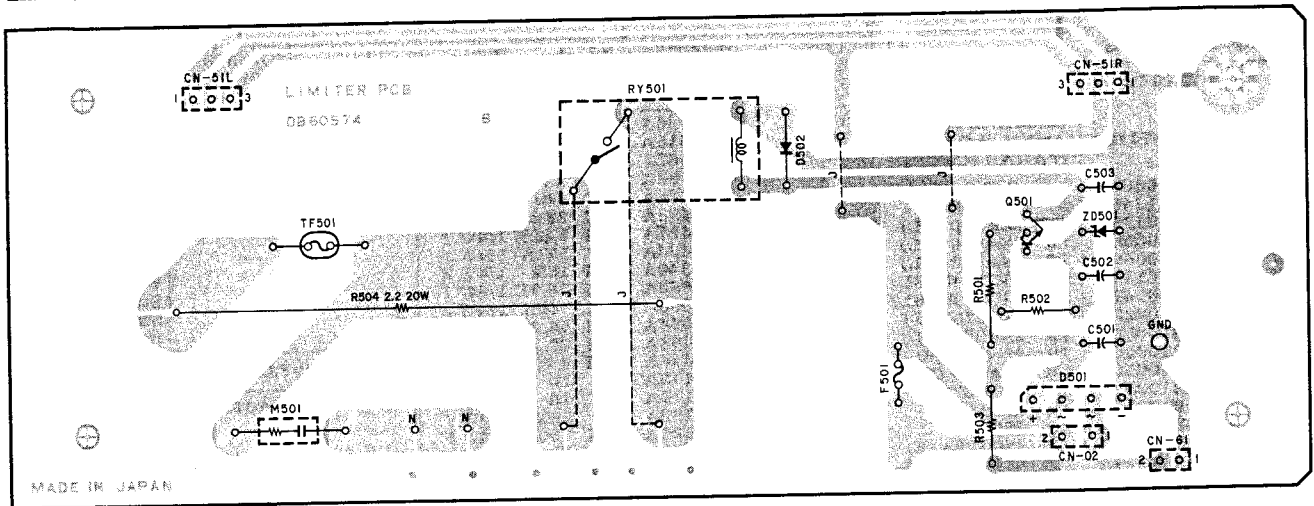

Fig. 6.3

6.4. Thermistor L P.C.B. Ass'y

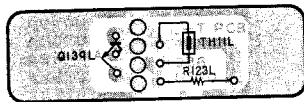

Fig. 6.4

6.5. Thermistor R P.C.B. Ass'y

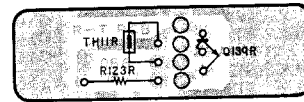

Fig. 6.5

Schematic Ref. No.	Part No.	Description	Schematic Ref. No.	Part No.	Description	Schematic Ref. No.	Part No.	Description
6.3. Limiter P.C.B. Ass'y			M501	OB90258A	Spark Killer Fuse 500mA (PA-7II (Australia & Saudi Arabia) & PA-7EII)	6.4. Thermistor L P.C.B. Ass'y		
	BA07264A	Limiter P.C.B. Ass'y (PA-7II (Australia & Saudi Arabia) & PA-7EII)	F501	OB08505A	Fuse 500mA (PA-7II (Other) & PA-7AII)	Q139L	BA07261A	Thermistor L P.C.B. Ass'y
	BA07263A	Limiter P.C.B. Ass'y (PA-7II (Other) & PA-7AII)	F501	OB90246A	Fuse 500mA (PA-7II (Other) & PA-7AII)	R123L	OB60570A	Thermistor L P.C.B. TR 2SC3423
	OB60574A	Limiter P.C.B. TR 2SC2705 (Y)	TF501	OB90322A	Thermal Fuse 126 Fuse Clip EP (PA-7II (Australia & Saudi Arabia) & PA-7EII) (2)	TH11L	OB10255A	RM 1K 1/4W F Thermistor 102AT-2 Thermal P.C.B. Cable (1)
	OB10222A	ZD 24V B2		OB90328A	Fuse Clip UL (PA-7II (Other) & PA-7AII) (2)	6.5. Thermistor R P.C.B. Ass'y		
	OB12195A	Diode Bridge DBA10		OB90327A	Fuse Clip UL (PA-7II (Other) & PA-7AII) (2)		BA07262A	Thermistor R P.C.B. Ass'y
	OB06282A	SiD 1SS53		OB883483A	AC L Cord D (PA-7II (Other) & PA-7AII) (1)	Q139R	OB60571A	Thermistor R P.C.B. TR 2SC3423
	OB07785A	RF 330 1W		OB883484A	AC L Cord E (PA-7II (Other) & PA-7AII) (1)	R123R	OB09491A	RM 1K 1/4W F Thermistor 102AT-2 Thermal P.C.B. Cable (1)
	OB09424A	RM 4.75K 1/4W F		OB883475A	Limitier GND Cord (1)	TH11R	OB19010A	
	OB24073A	RF 2.2K 1/2W					OB83341A	
	OB24093A	RC 2.2 20W						
	OB40120A	CE 100μ 50V						
	OB40119A	CE 47μ 50V						
	OB40120A	CE 100μ 50V						
	OB90326A	Limitier Relay 24VDC						
	OB81402A	2P-S Post						
	OB83329A	Limitier Cord Ass'y L						
	OB83330A	Limitier Cord Ass'y R						
	OB81179A	2P-S Post						

Schematic Ref. No.	Part No.	Description
R125R	OB24058A	RF 3 2W
R126R	OB24094A	RC 1 5W
R127R	OB24094A	RC 1 5W
R128R	OB24094A	RC 1 5W
R129R	OB24094A	RC 1 5W
R130R	OB24057A	RF 1 2W
R131R	OB24057A	RF 1 2W
R132R	OB24057A	RF 1 2W
R133R	OB24057A	RF 1 2W
R134R	OB24057A	RF 1 2W
R135R	OB24057A	RF 1 2W
R136R	OB24057A	RF 1 2W
R137R	OB24057A	RF 1 2W
R138R	OB24057A	RF 1 2W
R139R	OB24057A	RF 1 2W
R140R	OB24057A	RF 1 2W
R141R	OB24057A	RF 1 2W
R142R	OB24057A	RF 1 2W
R143R	OB24057A	RF 1 2W
R144R	OB09423A	RM 4.02K 1/4W F
R145R	OB22562A	RM 82.5K 1/4W F
R146R	OB22736A	RM 35.7K 1/4W F
R147R	OB09315A	RM 332K 1/4W F
R148R	OB22562A	RM 82.5K 1/4W F
R149R	OB24059A	RF 5.1 2W
R150R	OB07785A	RF 330 1W
R151R	OB09498A	RM 22.1K 1/4W F
R152R	OB09427A	RM 5.62K 1/4W F
R153R	OB09464A	RM 121K 1/4W F
R154R	OB09340A	RM 15K 1/4W F
R155R	OB09595A	RM 56.2K 1/4W F
R156R	OB09305A	RM 100K 1/4W F
R157R	OB09595A	RM 56.2K 1/4W F
R158R	OB09498A	RM 22.1K 1/4W F
R159R	OB09424A	RM 4.75K 1/4W F
R160R	OB24115A	RF 10 1/2W J
R161R	OB24115A	RF 10 1/2W J
R162R	OB24193A	RF 18K 1/2W J
R163R	OB09593A	RM 750 1/4W F
R164R	OB09446A	RM 33.2K 1/4W F
R165R	OB09491A	RM 1K 1/4W F
R166R	OB09491A	RM 1K 1/4W F
R167R	OB09491A	RM 1K 1/4W F
C101R	OB41795A	CSP 330P 160V J
C102R	OB41766A	CSP 4700P 160V J
C103R	OB41763A	CSP 10P 160V J
C104R	OB40502A	CE 220µ 16V (BP)
C105R	OB41766A	CSP 4700P 160V J
C106R	OB40517A	CE 10µ 35V
C107R	OB41892A	CML 0.1µ 200V
C108R	OB40078A	CE 100µ 16V
C109R	OB40177A	CE 10µ 50V
C110R	OB40174A	CE 2.2µ 50V
C111R	OB40079A	CE 220µ 16V
C113R	OB40176A	CE 4.7µ 50V
C114R	OB40504A	CE 330µ 100V
C115R	OB40504A	CE 330µ 100V
C116R	OB41196A	CSP 470P 160V J
C117R	OB41196A	CSP 470P 160V J
RY11R	OB90317A	Relay 24V
S101R	OB90084A	Thermal Switch 75°C
CN51R	OB81183A	3P-S Post (WHT)
TP11R	OB81185A	3P-S Post (RED)
TP12R	OB81184A	3P-S Post (BLK)
	OB81934A	3P-T Post (18)
	OB81964A	4P Terminal (1)
	OJ05211A	Heat Sink (2)
	OB81935A	LED Holder (1)
	OB83340A	Capacitor Ground Cord (1)
	OE03395A	M3x8 @ Binding (CU) (2)
	OB81933A	Screw Terminal P-436 (5)
	OJ05596A	Bus Plate (4)

6.6. Amp. L.P.C.B. Ass'y

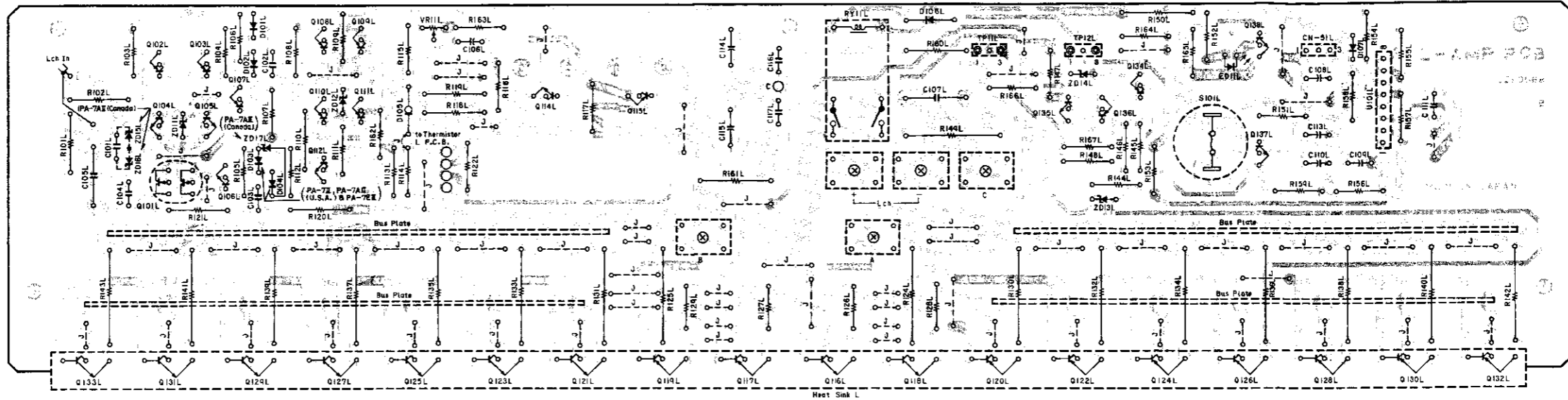

Fig. 6.6

6.7. Amp. R.P.C.B. Ass'y

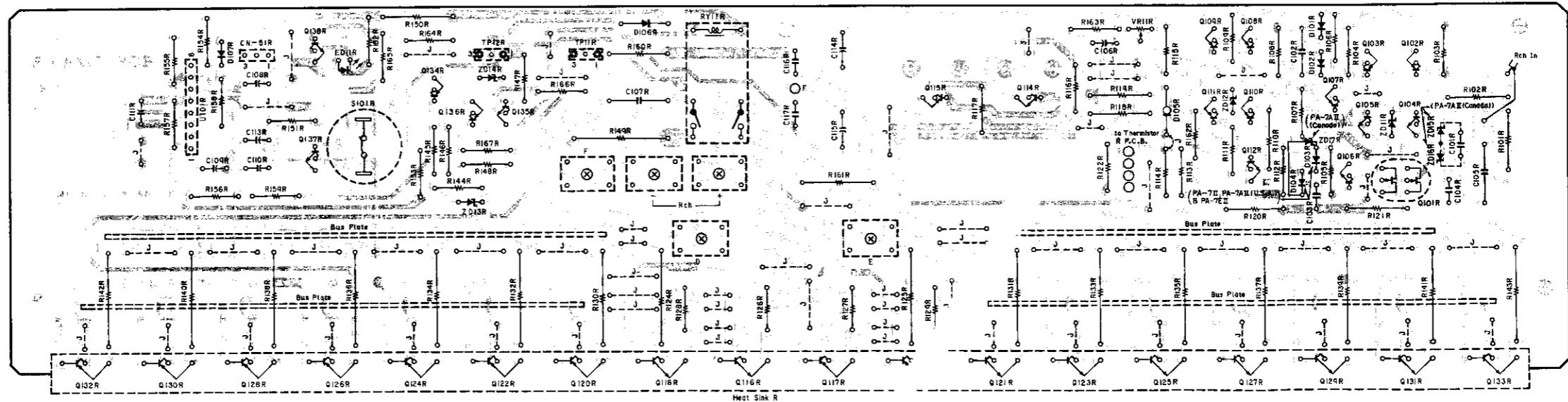
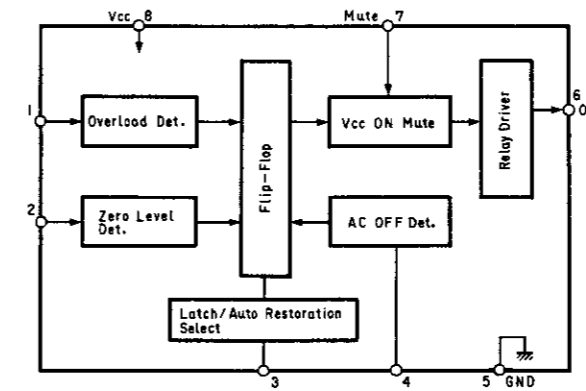
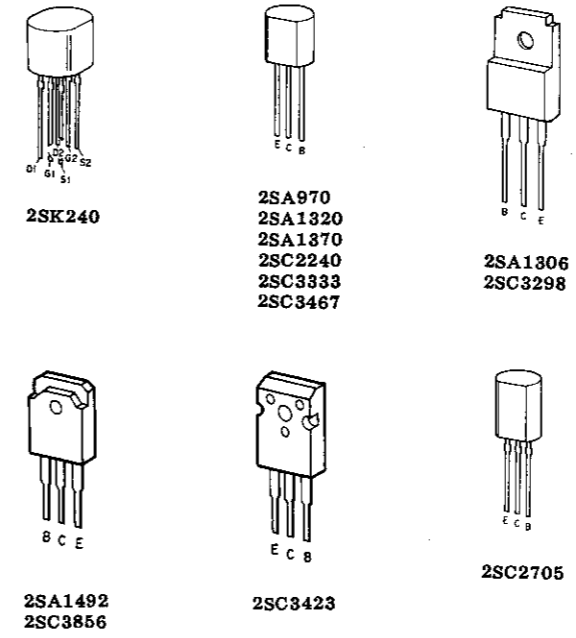

Fig. 6.7

Schematic Ref. No.	Part No.	Description	Schematic Ref. No.	Part No.	Description	Schematic Ref. No.	Part No.	Description
		Heat Sink R Ass'y	Q126R	OB10251A	TR 2SA1492		OJ05600A	Cooling Sheet B (2)
		Heat Sink R Ass'y	Q127R	OB10250A	TR 2SC3856		OJ05601A	Cooling Sheet A (1)
		Heat Sink R Ass'y	Q128R	OB10251A	TR 2SA1492		BA07262A	Thermistor R.P.C.B. Ass'y (1)
		Heat Sink R Ass'y	Q129R	OB10250A	TR 2SC3856			Heat Sink R (1)
		Heat Sink R Ass'y	Q130R	OB10251A	TR 2SA1492		OH05305A	M3x10 @ Binding (3A) (Nickel) (18)
		Heat Sink R Ass'y	Q131R	OB10250A	TR 2SC3856		OE03490A	M3x5 @ Binding (Nickel) (6)
		Heat Sink R Ass'y	Q132R	OB10251A	TR 2SA1492			Note: Exploded view is shown in Fig. 5.6. See item 5.6 "Heat Sink R Ass'y (A05)" on page 7.
		Heat Sink R Ass'y	Q133R	OB10250A	TR 2SC3856			
Q116R	OB10250A	TR 2SC3856		BA07260A	Amp. R.P.C.B. Ass'y (PA-7II, PA-7AII (U.S.A.) & PA-7EII) (1)			
Q117R	OB10251A	TR 2SA1492		BA07447A	Amp. R.P.C.B. Ass'y (PA-7AII (Canada)) (1)			
Q118R	OB10250A	TR 2SC3856						
Q119R	OB10251A	TR 2SA1492						
Q120R	OB10251A	TR 2SA1492						
Q121R	OB10250A	TR 2SC3856						
Q122R	OB10251A	TR 2SA1492						
Q123R	OB10250A	TR 2SC3856						
Q124R	OB10251A	TR 2SA1492						
Q125R	OB10250A	TR 2SC3856						

7. SCHEMATIC DIAGRAM



Power Amp. Protector IC μ PC1237H

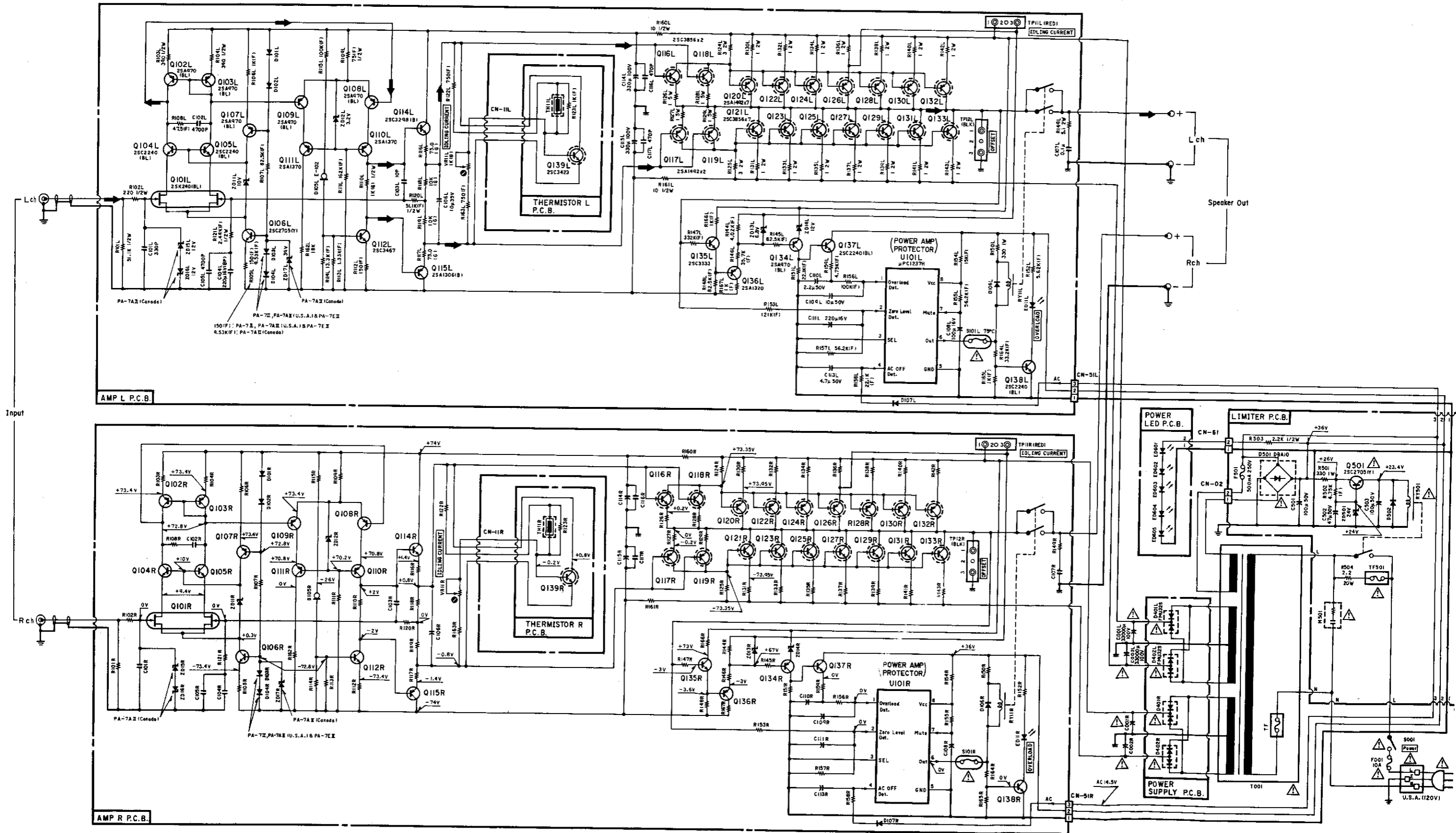
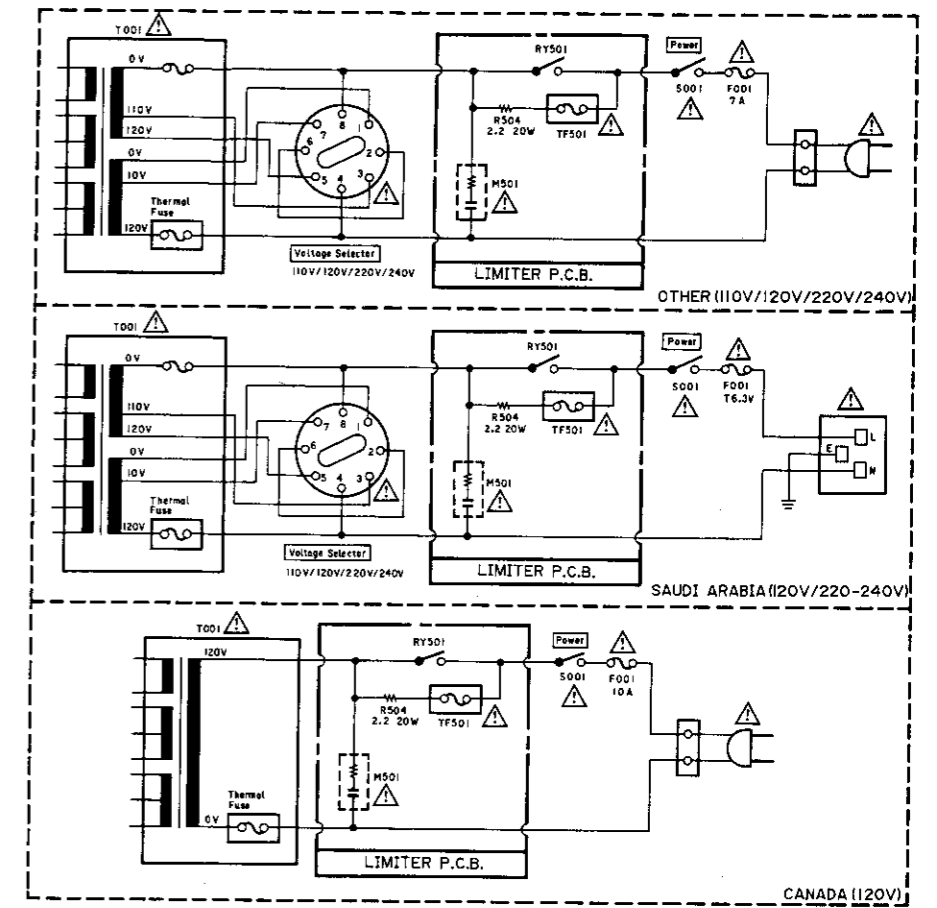
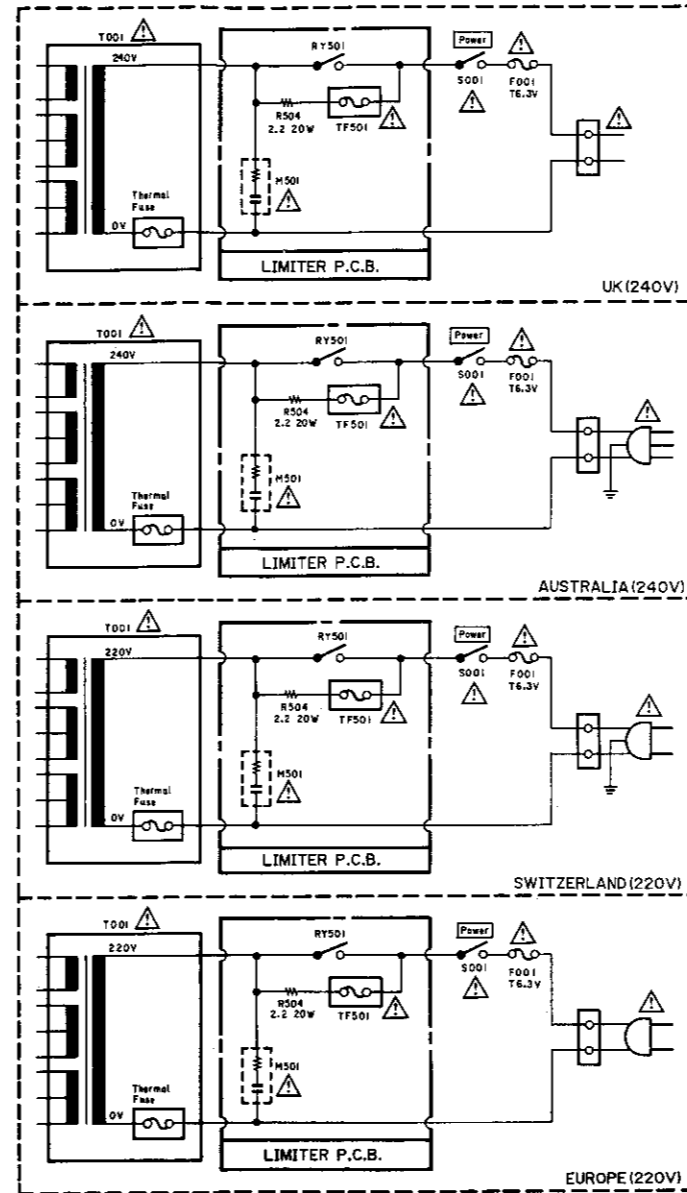
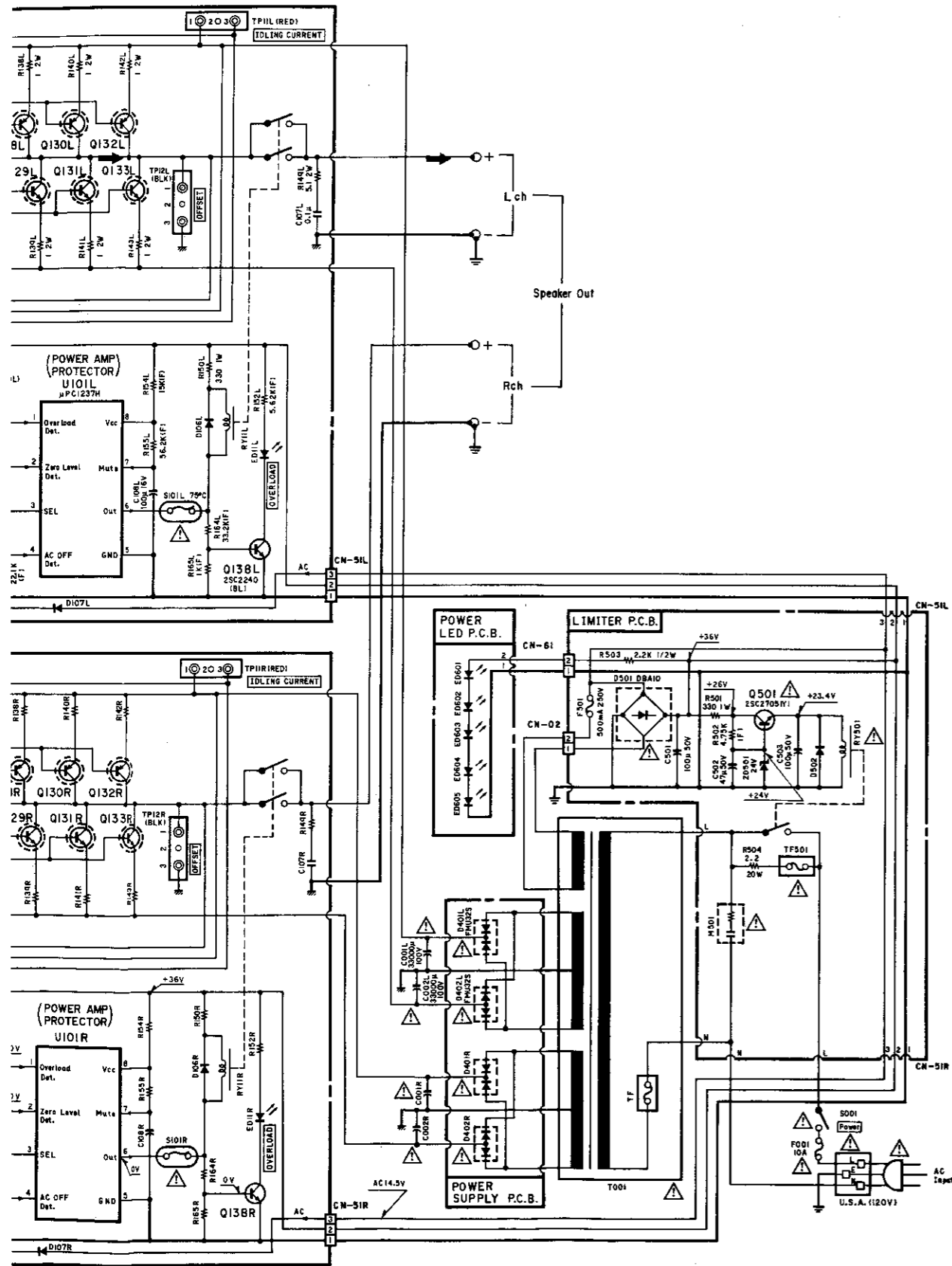



Fig. 7



- Notes: 1. Diode is 1S553, 1S1555, or 1S1176 unless otherwise specified.
 2. Voltage measuring condition:
 • With no input signal applied to the input terminals.
 • With no load connected to the speaker terminals.

WARNING:
 Parts marked with the symbol  have critical characteristics.
 Use ONLY replacement parts recommended by the manufacturer.
 It is recommended that the unit be operated from a suitable DC supply or batteries during initial check-out procedures.

CAUTION:
 Before returning the unit to the customer, make sure you make either (1) a leakage current check or (2) a line to chassis resistance check. If the leakage current exceeds 0.5 milliamp, or if the resistance from chassis to either side of the power cord is less than 240 k ohms, the unit is defective.
WARNING — DO NOT return the unit to the customer until the problem is located and corrected.

8. WIRING DIAGRAM

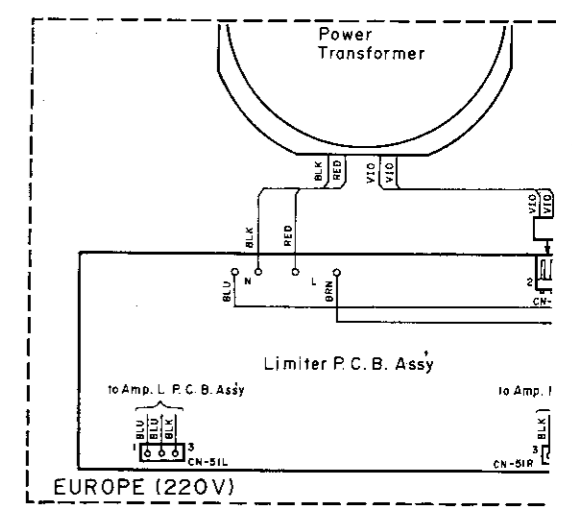
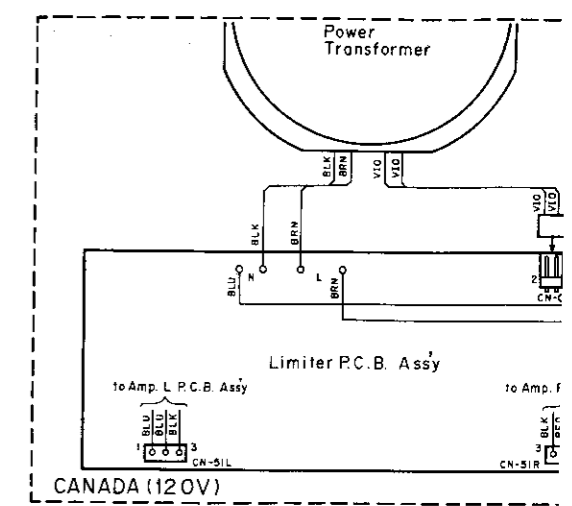
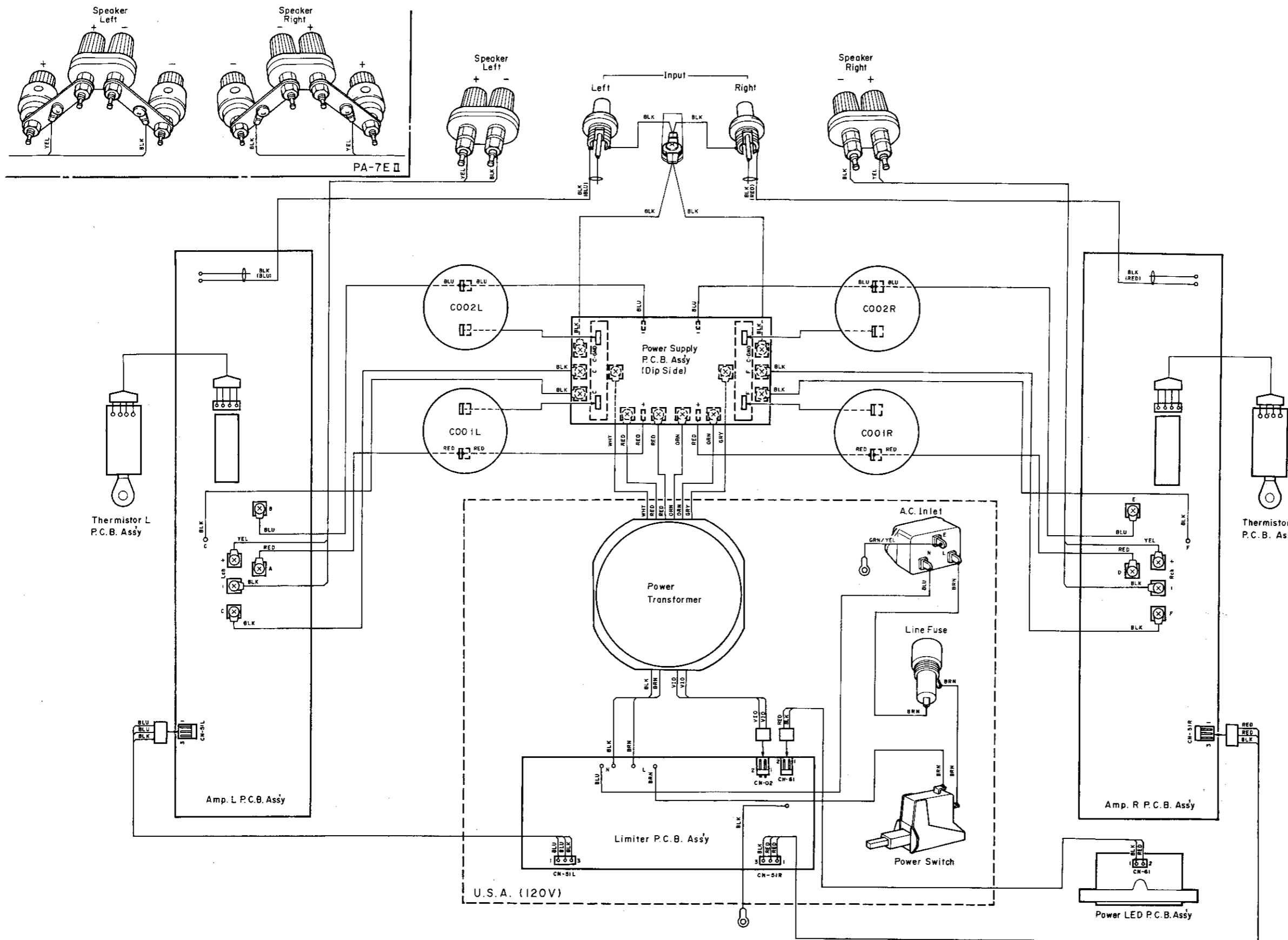

- Notes: 1. Table of wire colors
- | | |
|--------------|------------|
| BRN — Brown | BLU — Blue |
| RED — Red | VIO — Viol |
| ORN — Orange | GRY — Gray |
| YEL — Yellow | WHT — Whit |
| GRN — Green | BLK — Blac |
2. Component side view of the P.C.B. is il unless otherwise specified.
3. Wire tube color is shown in ().

Fig. 8.1

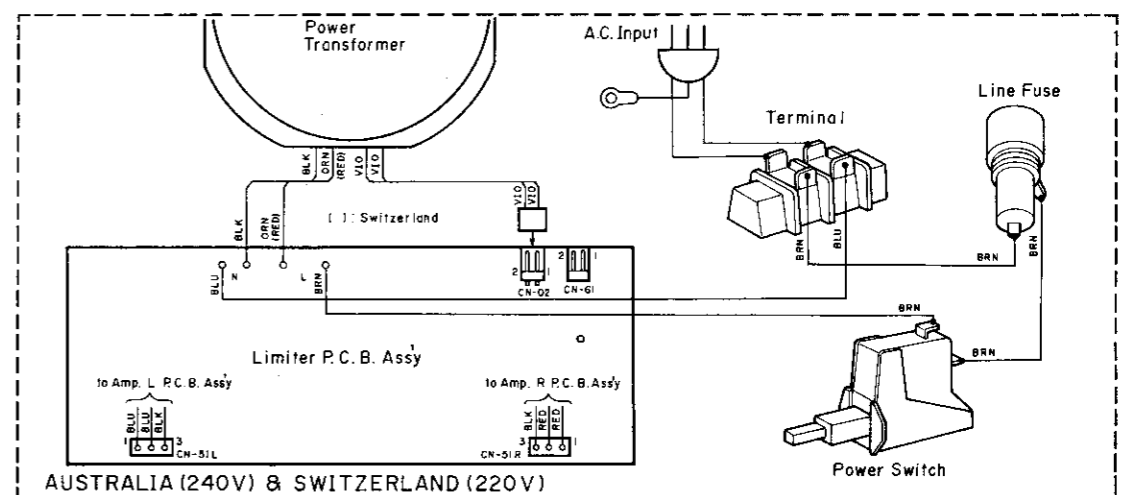
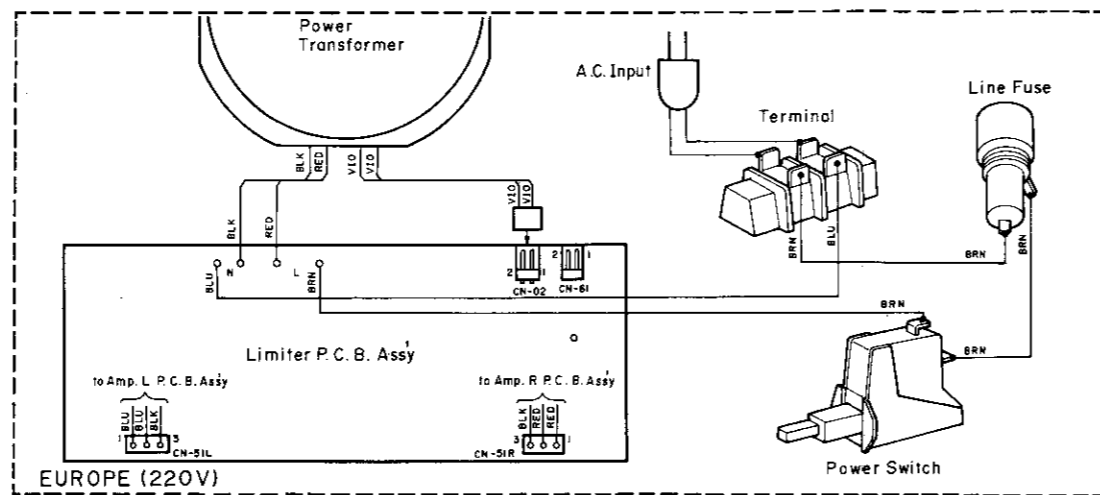
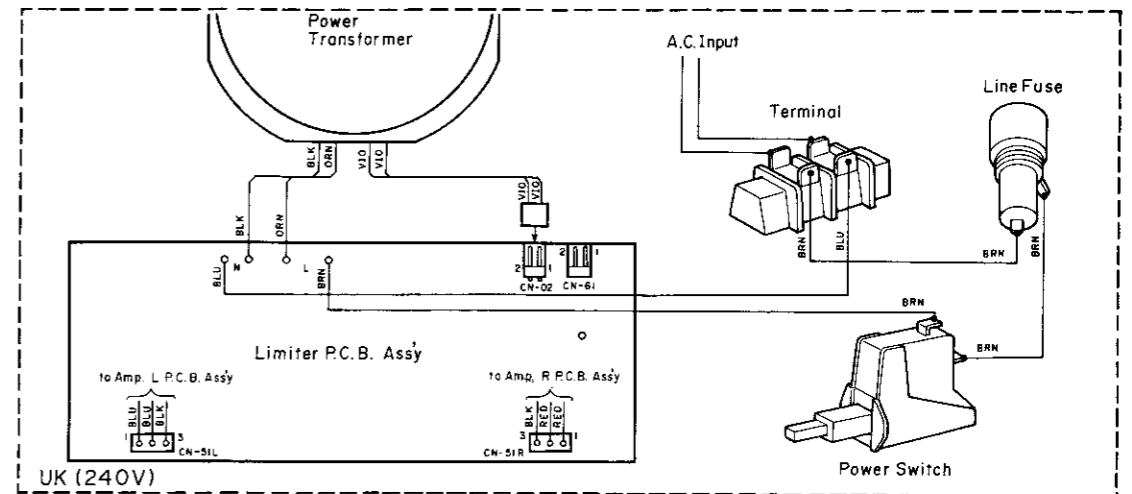
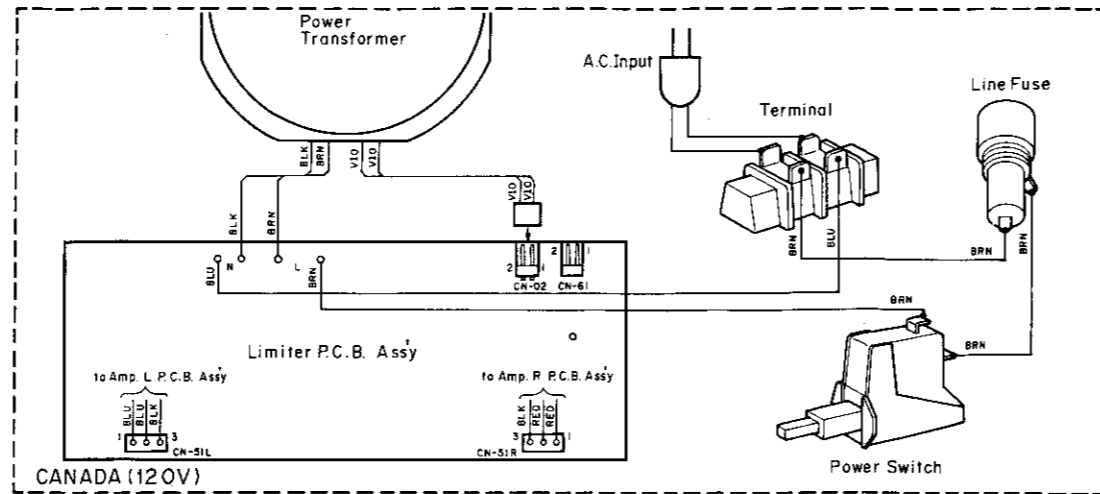
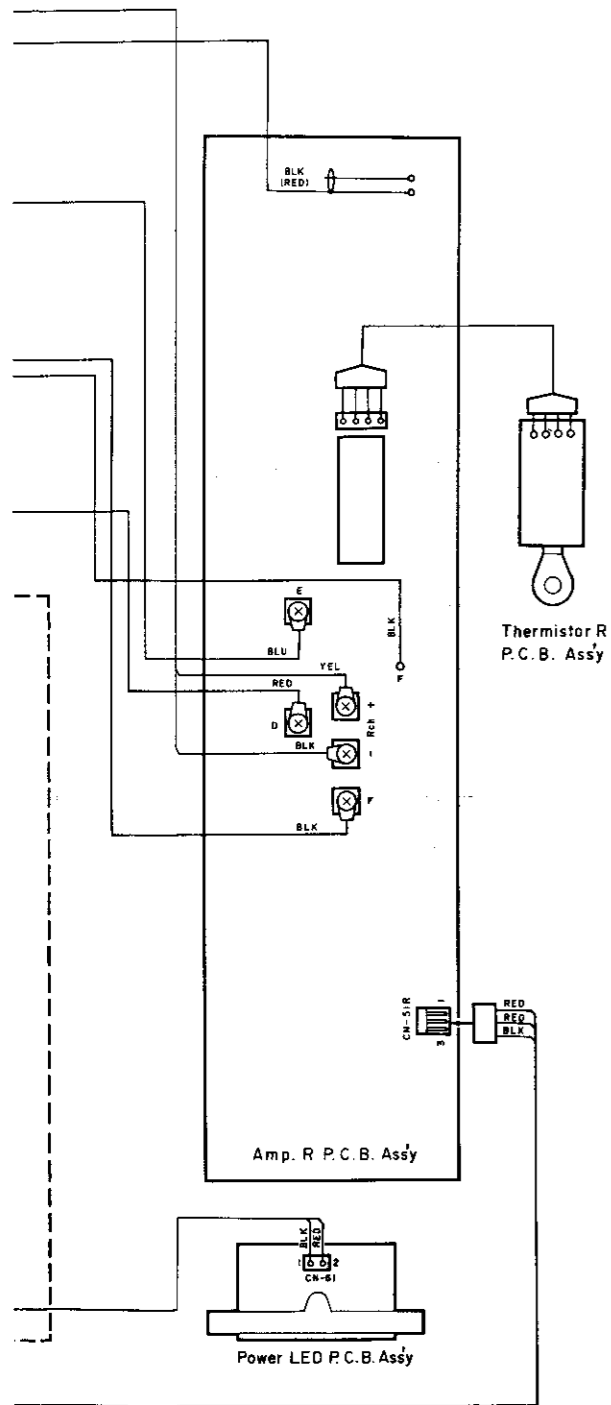

- Notes: 1. Table of wire colors
- | | |
|--------------|--------------|
| BRN - Brown | BLU - Blue |
| RED - Red | VIO - Violet |
| ORN - Orange | GRY - Gray |
| YEL - Yellow | WHT - White |
| GRN - Green | BLK - Black |
2. Component side view of the P.C.B. is illustrated unless otherwise specified.
3. Wire tube color is shown in ().

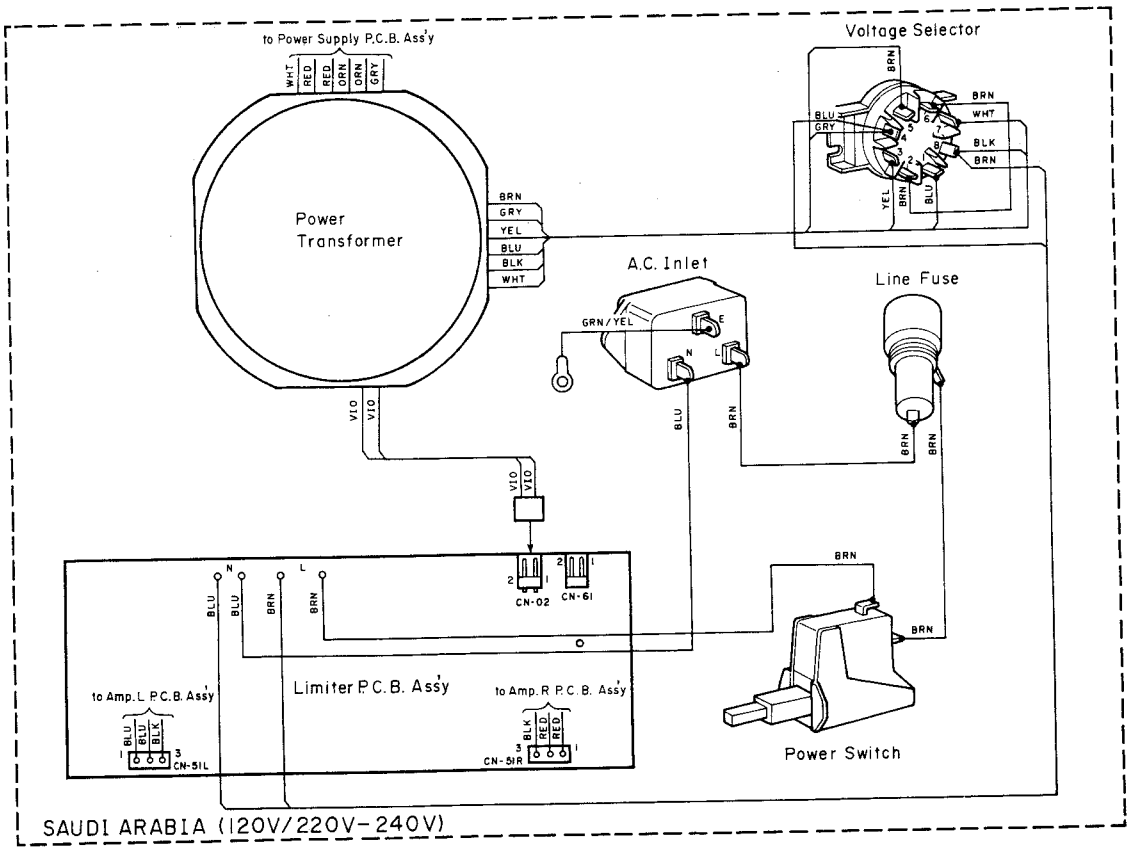
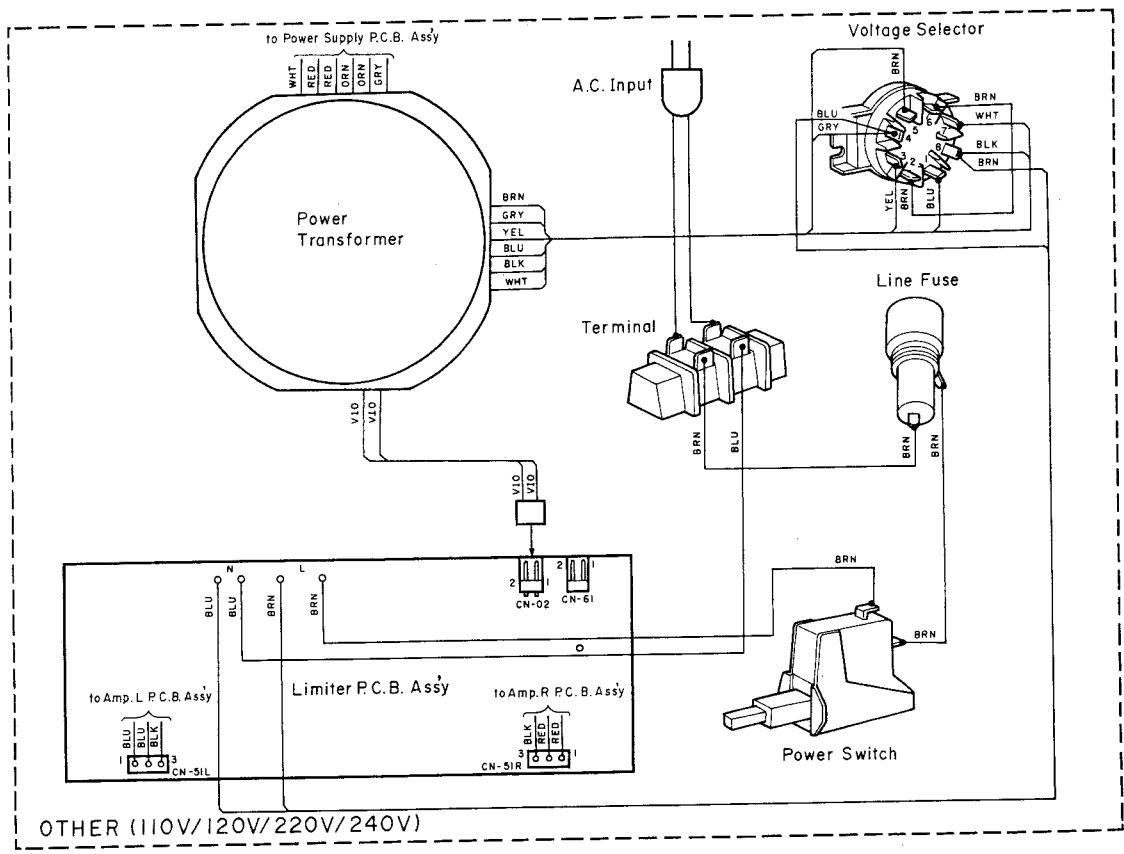

Fig. 8.2

9. BLOCK DIAGRAM

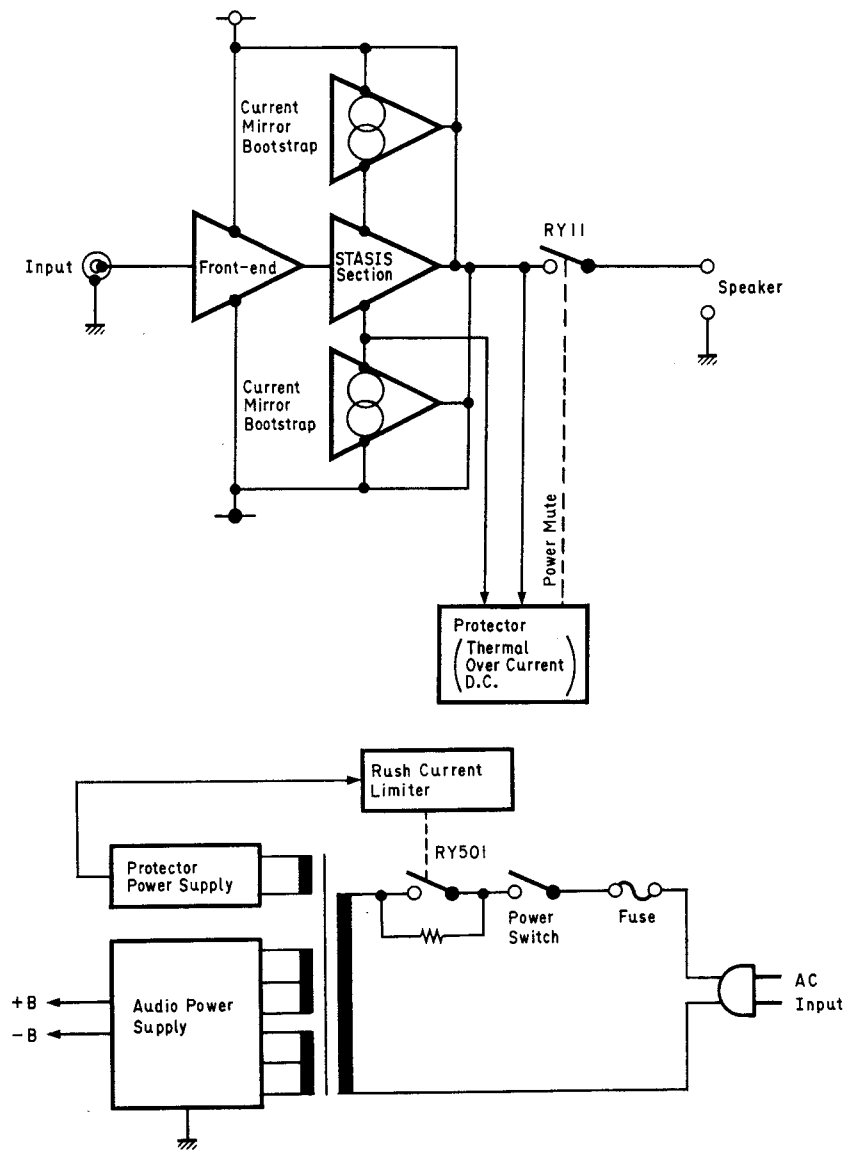

Fig. 9

10. SPECIFICATIONS

Continuous Average Power	225 W x 2 (8 ohms, both channels driven, 20—20,000 Hz, 0.05%, THD)
Output (NEW IHF)	
Dynamic Power per Channel	340 W (8 ohms)
Dynamic Head Room	1.7 dB (8 ohms)
(NEW IHF)	
Power Bandwidth (Half	5 Hz—50 kHz
Rated Power, 0.05% THD)	
Damping Factor (NEW IHF)	Greater than 60/60/60
20 Hz/1 kHz/20 kHz	
Input Sensitivity/Impedance	2.0 V/50 k ohms (rated power)
(NEW IHF)	140 mV/50 k ohms (1 W output)
Frequency Response (1 W,	20—20,000 Hz +0, -0.2 dB
NEW IHF)	7—150,000 Hz +0, -3 dB
Signal to Noise Ratio	Better than 120 dB
(Input Shorted, Rated Power,	
IHF A-WTD)	
Residual Noise Level	Less than 25 μ V
(IHF A-WTD)	
Total Harmonic Distortion	Less than 0.05%
(Rated Power, 20—20,000 Hz)	
Stereo Separation	120/105/90 dB
(Input Shorted)	
100 Hz/1 kHz/10 kHz	
Output Complement	18 transistors per channel
Output Current Capability	20 A continuous, 90 A peak (per channel)
Power Supply	700 VA toroidal transformer, 132,000 μ F total filter capacitance
Power Source	120, 220, 240 or 110/120/220/240 V AC; 50/60 Hz
	(According to country of sale)
Power Consumption	900 W max.
Dimensions	435 (W) x 200 (H) x 421 (D) mm
	17-1/8 (W) x 7-7/8 (H) x 16-9/16 (D) inches
Approximate Weight	28.5 kg; 62 lbs., 13 oz.

- Specifications and design are subject to change for further improvement without notice.
- STASIS manufactured under license from Threshold Corporation.
- STASIS is a trademark of Threshold Corporation.