



Service Manual

Nakamichi

OMS-4

OMS-4A

OMS-4E

OMS-40

Compact Disc Player

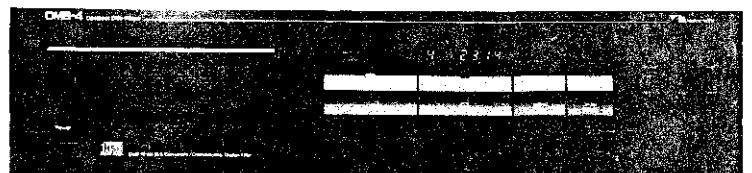

CONTENTS

1. GENERAL	3
2. REMOVAL PROCEDURES	4
2.1 TOP COVER ASS'Y AND BOTTOM COVER ASS'Y	4
2.2 SERVO P.C.B. ASS'Y	4
2.3 FRONT PANEL ASS'Y	4
2.4 CONTROL & DISPLAY P.C.B. ASS'Y	4
2.5 MAIN P.C.B. ASS'Y AND DISC MECHANISM ASS'Y	4
2.6 CHUCK ARM ASS'Y AND DISC TRAY ASS'Y	5
2.7 LASER PICKUP ASS'Y	5
2.8 DISC MOTOR	5
3. ADJUSTMENT PROCEDURES	6
3.1 INSTRUMENTS AND GAUGE	6
3.2 PARTS LOCATION FOR ADJUSTMENT	6
3.3 LASER POWER CHECK	7
3.4 VCO ADJUSTMENT ON MAIN P.C.B. ASS'Y	7
3.5 ADJUSTMENT OF SERVO P.C.B. ASS'Y	8
3.6 DISTORTION ADJUSTMENT	9
3.7 OPERATION CHECK	10
4. MECHANISM ASS'Y AND PARTS LIST	11
4.1 SYNTHESIS	11
4.2 CHASSIS ASS'Y	12
4.3 FRONT PANEL ASS'Y	13
4.4 TOP COVER ASS'Y	13
4.5 BOTTOM COVER ASS'Y	13
4.6 DISC MECHANISM ASS'Y	14
4.7 LOADING GEAR ASS'Y	15
4.8 CHUCK ARM ASS'Y	15
5. MOUNTING DIAGRAMS AND PARTS LIST	16
5.1 MAIN P.C.B. ASS'Y	16
5.2 SERVO P.C.B. ASS'Y	18
5.3 SEARCH P.C.B. ASS'Y	20
5.4 CONTROL AND DISPLAY P.C.B. ASS'Y	20
5.5 SIGNAL PROCESS P.C.B. ASS'Y	22
5.6 D F/F P.C.B. ASS'Y	22
5.7 DAC P.C.B. ASS'Y	23
5.8 RAM P.C.B. ASS'Y	23
5.9 ANALOG FILTER P.C.B. ASS'Y	23
5.10 HEADPHONE AMP. P.C.B. ASS'Y	24
5.11 TERMINAL P.C.B. ASS'Y	24
5.12 PHOTO TRANSISTOR P.C.B. ASS'Y	24
5.13 PHOTO DIODE P.C.B. ASS'Y	24
6. IC BLOCK DIAGRAMS	25
7. SCHEMATIC DIAGRAM	34
8. WIRING DIAGRAM	35
9. BLOCK DIAGRAM	36
10. SPECIFICATIONS	37

1. GENERAL

1.1 PACKING MATERIALS and OWNER'S MANUAL

The OMS-4/4A/4E/40 is equipped with the Remote Control Unit RM-4-CD.
The Remote Control Unit RM-4CD will be supplied per unit as for space parts.

<u>Part No.</u>	<u>Description</u>	<u>Q'ty</u>
0C81615A	Carton Box OMS-4	1
0C81612A	Carton Box OMS-4A	1
0C81616A	Carton Box OMS-4E	1
0C81617A	Carton Box OMS-40	1
0D04640B	Owner's Manual (English)	1
0D04642A	Owner's Manual (Japanese)	1
0D04641A	Owner's Manual (English/German/French)	1
CA80519A	Remote Control Unit	1

1.2 WARNING

1.2.1 IN SERVICE MANUAL

This unit uses an invisible semiconductor laser to pick up the digital signal on the disc. Since the laser can take the signal without contact, there's no anxiety of rubbing down the disc and the Pickup Ass'y.

But you must treat the laser with the greatest of care. In servicing, please pay attention to the following.

- 1) Avoid direct exposure to beam.
Laser can be radiated when the interlocks fail or are defeated.
- 2) Do not break up the Laser Pickup Ass'y.
- 3) Referred to in item 2.7 Laser Pickup Ass'y on page 5.

1.2.2 LASER SPECIFICATION

The laser provided in the unit is GaAlAs semiconductor laser. The theory of the laser emitting is the same as the light emitting of LEDs. The difference is that the laser has only one wavelength and is coherent.

One of the characteristics of laser diodes is that the threshold level can be changed accordance with the surrounding temperature. To correct this characteristic, the laser diode used in this unit provides a monitor photo diode and controls the output power level of the laser to be constant.

The Laser Pickup Ass'y consists of a laser diode, 6-split photodiode, object lens, beam splitter and coils. The object lens moves forward or back by the focus servo coil and also moves left or right by the tracking servo coil. The laser passes through the prisms and the lenses and is emitted through the object lens. The power of it is decreased to 0.3mW passing through these optical instruments. The laser reflected by the disc passes through the optical instruments again and detected by the 6-split photo diode.

1.2.3 CAUTION

Before returning the unit to the customer, make sure you make either (1) a leakage current check or (2) a line to chassis resistance check. If the leakage current exceeds 0.5 milliamp, or if the resistance from the chassis to either side of the power cord is less than 240k ohms, the unit is defective.

WARNING – DO NOT return the unit to the customer until the problem is located and corrected.

1.2.4 Main P.C.B

The Main P.C.B. Ass'y C230, C231, C501 – C509, C510, C520, C351, C353, C215, are attached with Sony Bond SC12N.

After replacing any of these components, be certain to apply them with Sony Bond SC12N.

2. REMOVAL PROCEDURES

2.1. Top Cover Ass'y and Bottom Cover Ass'y

- (1) Refer to Fig. 2.1.
- (2) Remove F01 and F02, then lift and remove F03 (Top Cover Ass'y).
- (3) Remove F04, F05, F06 and F07, then lift and remove F08 (Bottom Cover Ass'y).

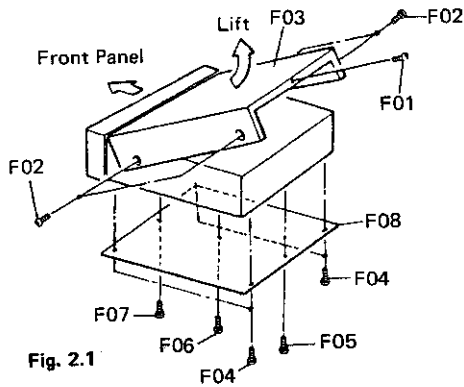

Fig. 2.1

2.2. Servo P.C.B. Ass'y

- (1) Refer to Fig. 2.2 and Fig. 2.3.
- (2) Remove the Top Cover Ass'y and the Bottom Cover Ass'y referred to in item 2.1.
- (3) Remove F01 and F02 (P.C.B. Support) and five connectors (CN-101, CN-102, CN-103, CN-202 and CN-203), then F03 (Servo P.C.B. Ass'y).

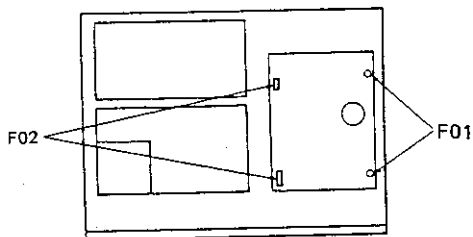

Fig. 2.2

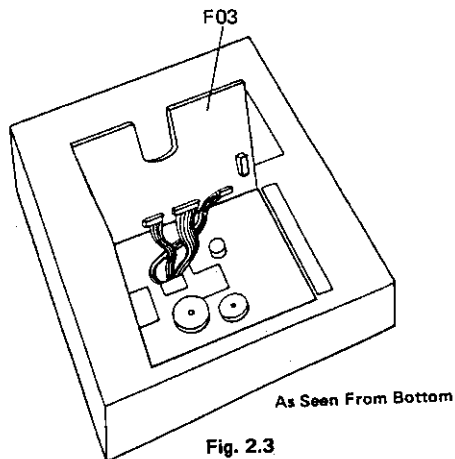

Fig. 2.3

2.3. Front Panel Ass'y

- (1) Refer to Fig. 2.4 and Fig. 2.5.
- (2) Remove the Top Cover Ass'y and the Bottom Cover Ass'y referred to in item 2.1.
- (3) Eject the Disc Tray Ass'y and remove F01 (Disc Drawer Cover) by pressing it down with your fingers.
- (4) Remove F02 and F03, then release the latches located on both sides of the Chassis.
- (5) Remove two connectors (CN-401 and CN-402), then F04 (Front Panel Ass'y).

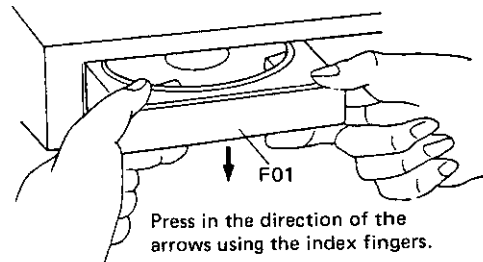

Fig. 2.4

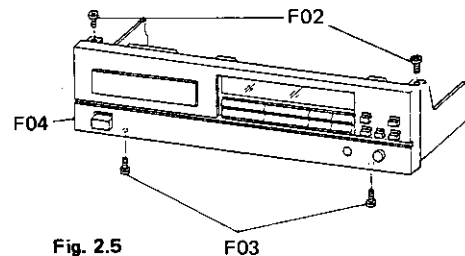

Fig. 2.5

2.4. Control & Display P.C.B. Ass'y

- (1) Refer to Fig. 2.6.
- (2) Remove the Front Panel Ass'y referred to in item 2.3.
- (3) Remove F01, then release the latches located on the Front Panel Ass'y, then F02 (Control & Display P.C.B. Ass'y).

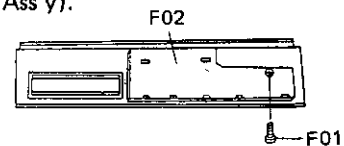

Fig. 2.6

2.5. Main P.C.B. Ass'y and Disc Mechanism Ass'y

- (1) Refer to Fig. 2.7.
- (2) Remove the Front Panel Ass'y referred to in item 2.3.
- (3) Remove F01, F02, F03, F04 (P.C.B. Holder), F05, F06 and F07, then F08 (Main P.C.B. Ass'y).
- (4) Remove F09, then F10 (Disc Mechanism Ass'y).

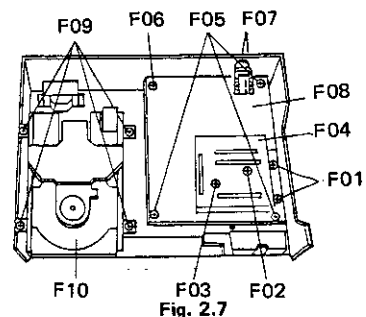

Fig. 2.7

2.6. Chuck Arm Ass'y and Disc Tray Ass'y

- (1) Refer to Fig. 2.8.
- (2) Remove the Front Panel Ass'y referred to in item 2.3.
- (3) Remove F01, then F02 (Chuck Arm Plate), F03 (Chuck Arm Spring), F04 and F05 then F06 (Chuck Arm Ass'y).
- (4) Remove F07 and F08, then F09 (Disc Drawer Guide L), F10 (Disc Drawer Guide R), then F11 (Disc Tray Ass'y).

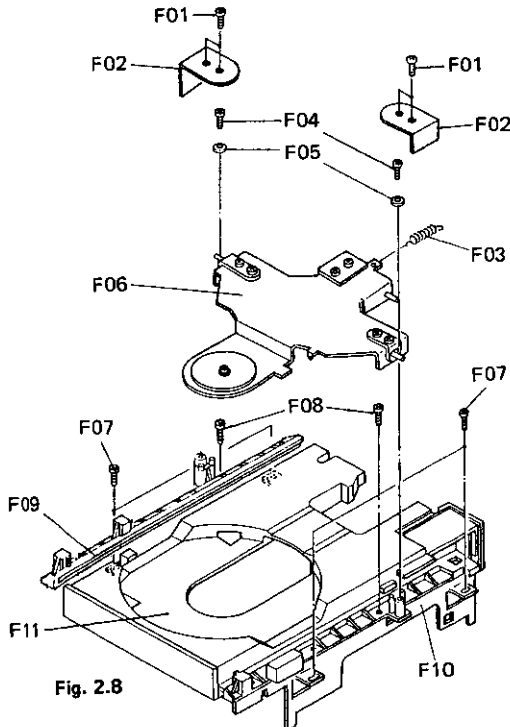

Fig. 2.8

2.7. Laser Pickup Ass'y

- (1) Refer to Fig. 2.9.
- (2) Remove the Disc Tray Ass'y referred to in item 2.6.
- (3) Remove the three connectors (CN-101, CN-102 and CN-103) from the Servo P.C.B. Ass'y.
- (4) Remove F01, then F02 (Laser Pickup Ass'y) along with F03 (Pickup Guide Rail).

NOTE: IF IT IS NOT CERTAIN THAT THE LASER PICK-UP ASS'Y IS DEFECTIVE, DO NOT REMOVE THE THREE CONNECTORS (CN-101, CN-102 and CN-103). IF YOU REMOVE THESE THREE CONNECTORS, THE LASER DIODE OF THE LASER PICKUP ASS'Y WILL BE DAMAGED.

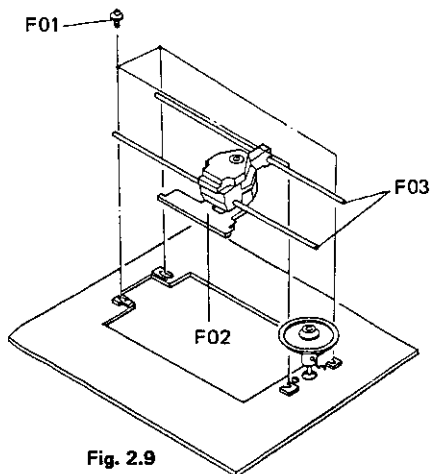

Fig. 2.9

Installing a new Laser Pickup Ass'y

- (1) When installing a new Laser Pickup Ass'y you must connect its three connectors (CN-101, CN-102 and CN-103) to the Servo P.C.B. Ass'y first.
- (2) Then using a grounded tip soldering iron only, remove the short-circuiting solder in the area of the dotted circle as shown in Fig. 2.10; this small P.C.B. which is incorporated with the Laser Pickup Ass'y.

CAUTION: IF THE SHORT-CIRCUITING SOLDER IS REMOVED BEFORE THE THREE CONNECTORS (CN-101, CN-102 and CN-103) ARE CONNECTED, DAMAGE TO THE LASER DIODE OF THE LASER PICKUP ASS'Y COULD OCCUR IN A MATTER OF SECONDS, CAUSING FAILURE OF THE NEW LASER PICKUP ASS'Y.

NOTE: THE LASER PICKUP ASS'Y STOCKED AS SPARE PART, MUST BE SHORTED TO DOTTED CIRCLE OF THE SMALL P.C.B. WHICH IS INCORPORATED WITH THE LASER PICKUP ASS'Y AS SHOWN IN Fig. 2.10.

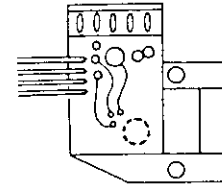

Fig. 2.10

2.8. Disc Motor

- (1) Refer to Fig. 2.11.
- (2) Remove Disc Tray Ass'y referred to in item 2.6.
- (3) Remove F01, then pull up F02 (Turntable B Ass'y)
- (4) Remove F03, then F04 (Disc Motor).

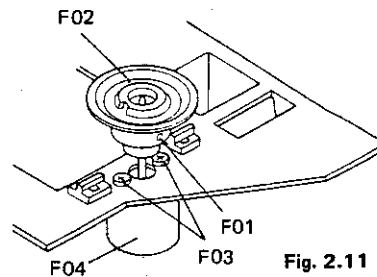

Fig. 2.11

RE-ASSEMBLY OF THE DISC MOTOR:

- (1) Refer to Fig. 2.12.
- (2) When re-assembling the Disc Motor, adjust the height of the turntable using the Turntable Adjustment Gauge (0C82258A).

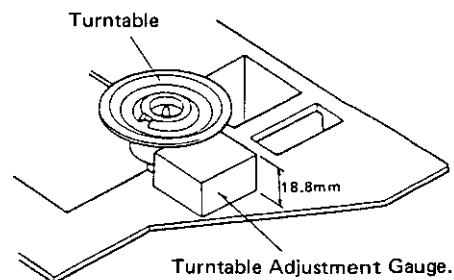
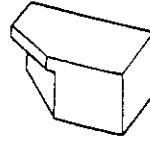

Fig. 2.12

3. ADJUSTMENT PROCEDURES

3.1 Meters and Gauge

- (1) Oscilloscope (15 MHz or more)
- (2) AC Voltmeter
- (3) DC Voltmeter
- (4) Optical Power Meter
- (5) Phillips Test Sample Disc 5/5A
- (6) Sony Test C.D. Type III (YEDS-7)
- (7) Frequency counter
- (8) Distortion Meter
- (9) Turntable Adjustment Gauge (Fig. 3.1)



Turntable Adjustment Gauge (0C82258A)

Fig. 3.1

3.2 Parts Location for Adjustment

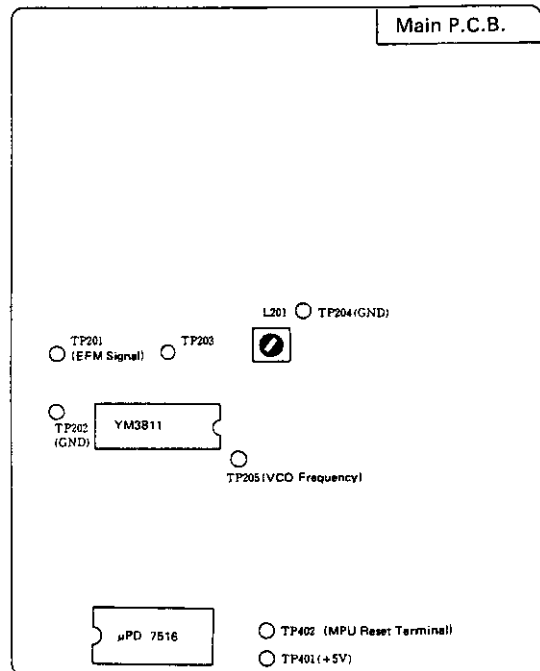
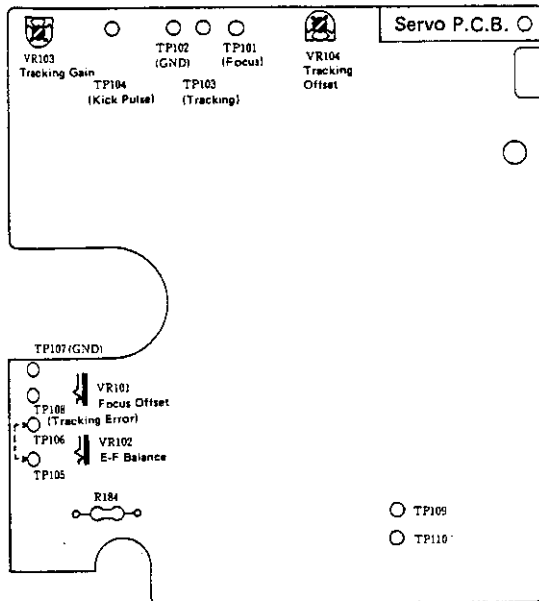

NOTE: The above Semi-fixed VR positions are for initial presetting.

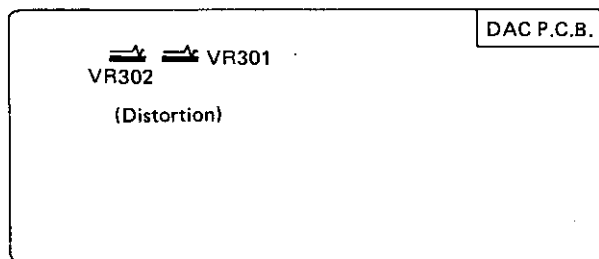

Fig. 3.2

3.3 Laser Pickup Laser Power Check

- (1) Remove the Top Cover Ass'y referred to in item 2.1 on page 4.
- (2) Short-circuit TP105 and TP106 located on the Servo P.C.B. Ass'y.
- (3) Place the optical power meter against the pickup (Fig. 3.3), and check that the laser power is between 0.15mW and 0.4mW.

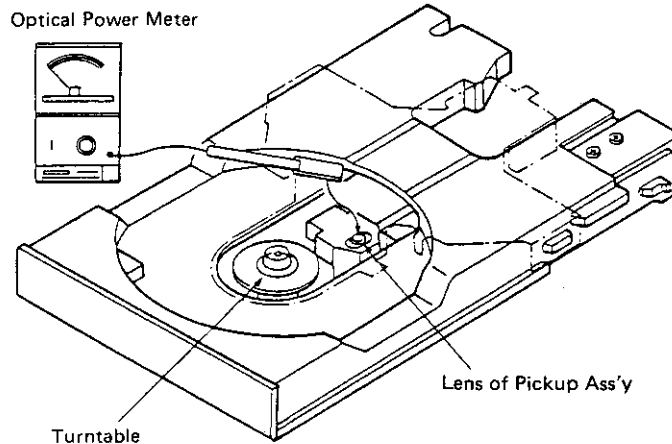

Fig. 3.3

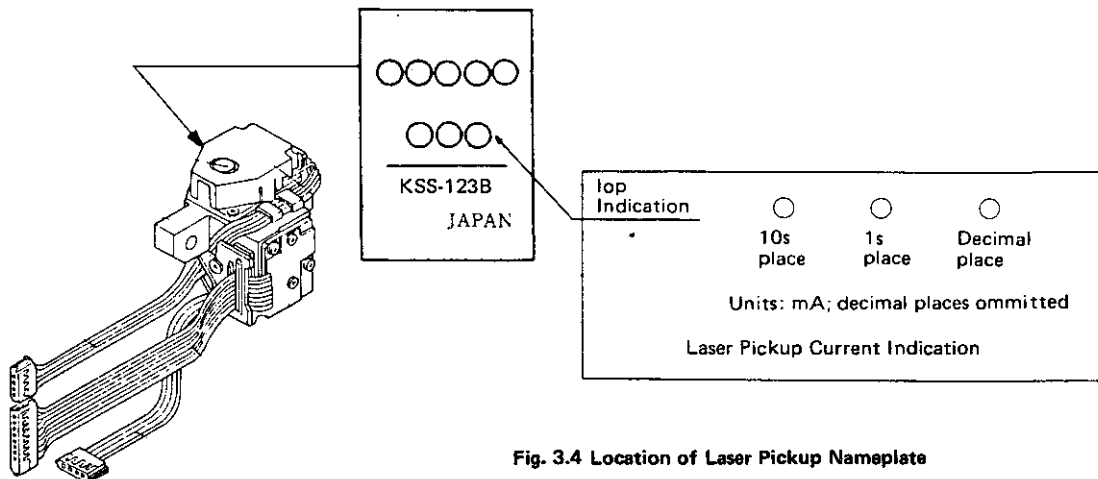

Fig. 3.4 Location of Laser Pickup Nameplate

3.4 Adjustment of VCO on Main P.C.B. Ass'y

3.4.1 VCO Frequency Adjustment (OMS-4 is No signal.)

- (1) Connect the frequency counter to TP205 (VCO Frequency) and TP204 (GND).
- (2) Remove CN-203 connector cord, turn the power switch on, and short-circuit TP201 and TP202.
- (3) Rotate the L201 core and adjust so that the frequency counter shows a value of 4.322MHz.
- (4) After adjusting, turn the power off and connect the CN-203 connector cord.

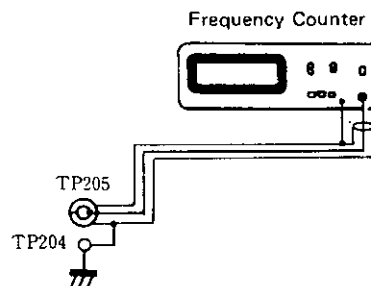

Fig. 3.5

3.5 Adjustment of Servo P.C.B. Ass'y

3-5-1 Setting of initial position of the semi-fixed volume

Before adjusting, preset all semi-fixed volumes are their mechanical center (VR101, 102, 103, 104).

3.5.2 Tracking Offset Adjustment

- (1) Rotate VR103 fully clockwise.
- (2) Short circuit TP105 and TP106, and without inserting a disc adjust VR104 so that the voltage of TP103 (Tracking Coil Output) and TP102 (GND) is $0 \pm 5\text{mV}$.
- (3) Disconnect TP105 and TP106, then preset VR103 to mechanical center.

3.5.3 Focus Offset Adjustment

- (1) Connect a DC voltmeter across R184 (120Ω) on Servo P.C.B. Ass'y.
- (2) Short circuit TP105 and TP106 (Laser Power On) on Servo P.C.B. Ass'y.
- (3) Turn the power switch on, and calculate the current from voltage on both ends of R184, and check that the difference compared to the laser pickup indication (Fig. 3.6) is within $\pm 10\%$ for the negative side. Next turn the power switch off and disconnect the AC voltmeter.
- (4) Turn the power back on, set the Philips Test Sample 5 test disc, and observe the TP201 output waveform (EFM signal).
- (5) Adjust the VR101 so that the EFM signal level becomes high and the waveform becomes distinct, so that the lines are not thick (Fig. 3.6).

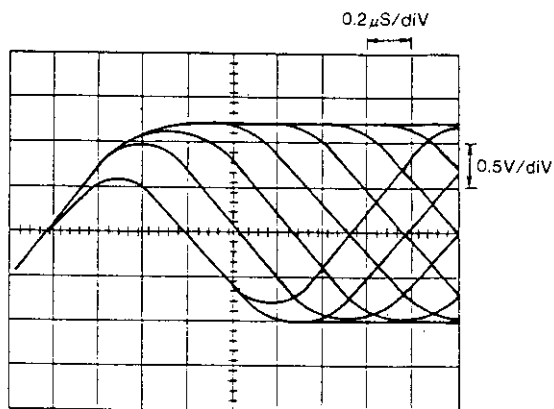

Focus Offset VR (VR101) Adjustment

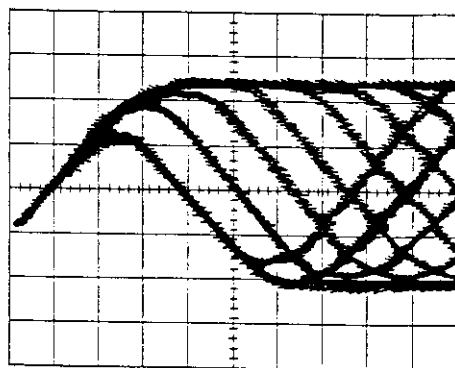

Focus Offset VR (VR101) at Maximum
(Level is high but waveform is unclear)

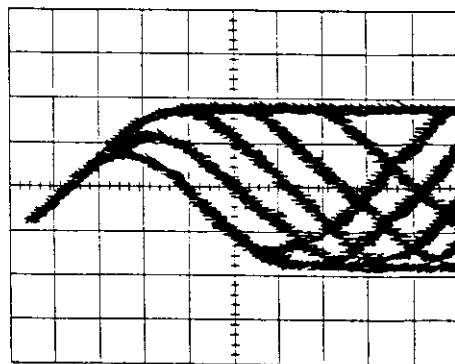

Focus Offset VR (VR101) at Minimum
(Level is low and waveform is unclear)

Fig. 3.6 Focus Offset VR EFM Signal Waveforms

3.5.4 E-F Balance Adjustment (Supplementary Beam Balance Adjustment)

- (1) Turn the power off and use a $10k\Omega$ resistor to short TP105 and TP106.
- (2) Connect the oscilloscope between TP201 (EFM signal) and TP202 (GND), and also between TP108 (Tracking Error) and TP107 (GND).
- (3) Turn the power switch, load the Philips Test Sample 5 test disc and playback from the first selection.
- (4) Connect TP402 (MPU Reset Terminal) and TP401 (+5V) on the Main P.C.B. Ass'y.
(As the microprocessor is in the Reset mode, the LED does not light)
- (5) Rotate VR103 (Tracking) fully clockwise.
 - a) Oscilloscope Ranges
 - b) Voltage Range (AC): CH1 1V
CH2 2V
 - c) (Set trigger on CH2)
 - d) Sweep Range: 1mS
- (6) Observe the tracking error waveforms (Fig. 3.7) and adjust VR102 so that the GND line is positioned at exactly half the waveform P-P value.
- (7) Turn the power switch off, disconnect the oscilloscope, TP401 (+5V) and TP402 (MPU Reset terminal), and set VR103 to the mechanical center.

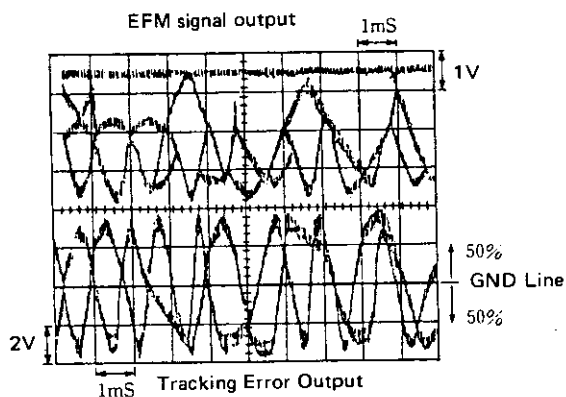

Fig. 3.7

3.6 DISTORTION ADJUSTMENT

- (Adjust after the Servo P.C.B. adjustment has been completed) Play the 20th selection on the Sony Type III test disc (1kHz - 60dB). Connect the L.P.F. (20kHz) to the AC voltmeter and the distortion meter. Adjust the VR301/302 so that distortion in the 3% range is as low as possible.
- > Dynamic range is greater than 91 dB.
 - < Check to make sure that distortion is below 0.007%.

3.5.5 Tracking Gain Adjustment

- (1) Load the Philips Test Sample 5 test disc (non-scratched), observe the noise voltage on the voltmeter, and adjust VR103 so that the noise voltage on TP103 (Tracking) and TP102 (GND) is $0.26V_{RMS} \pm 0.01V$ (Fig. 3.8).

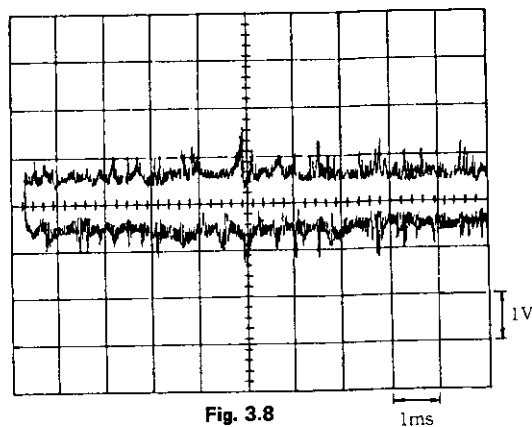

Fig. 3.8

3.5.6 Lens Kick Gain Check

- (1) Connect TP201 (EFM signal) and TP202 (GND) to CH1 on the oscilloscope, and TP104 (lens kick pulse) and TP102 (GND) to CH2.
- (2) Insert the Philips Test Sample 5 test disc and check the size of the TP201 (EFM signal) output waveform (Fig. 3.9).
- (3) Pause at selection 10 on the Philips Test Sample 5 test disc.

Oscilloscope Range:
Voltage Range (AC): CH1 . . . 1V
CH2 . . . 2V
Sweep Range: 0.2ms

Set a trigger on the leading edge of the TP104 waveform on CH2 (Lens Kick) and observe the TP201 waveform (Fig. 3.10).

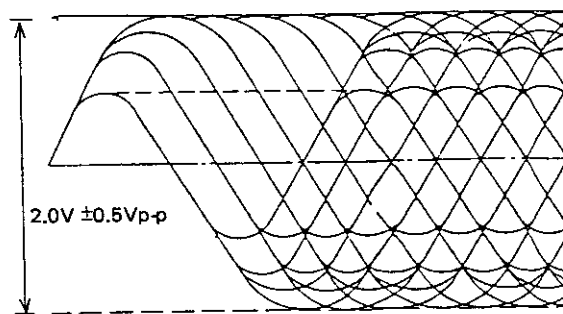

Fig. 3.9 EFM Signal

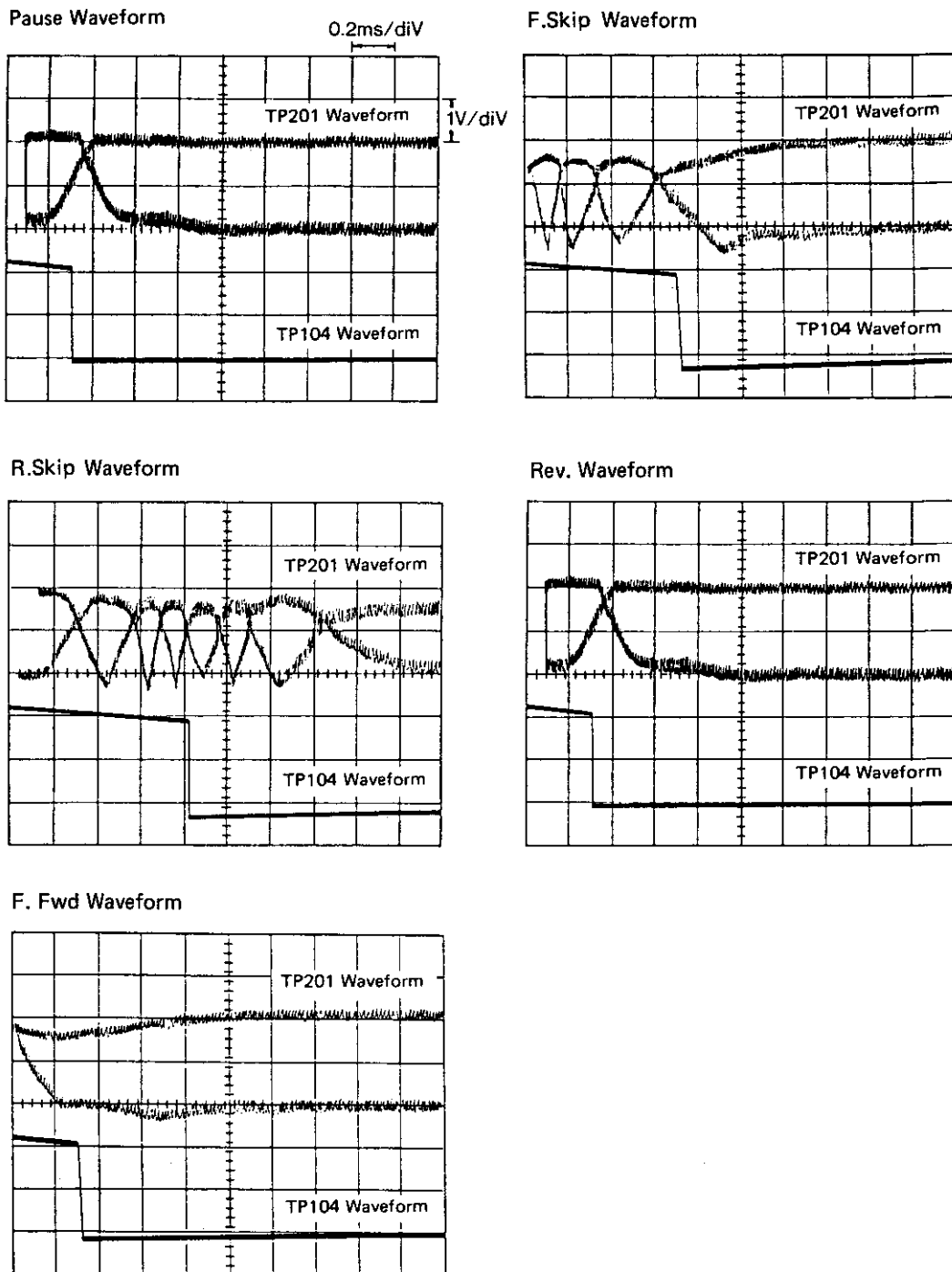

Fig. 3.10 EFM Signal Waveforms Upon Track Jump

3.7 Operation Check

3.7.1 Playability

Use the Philips Test 5A (scratched) test disc, play the following portions and make sure no tracks are jumped.

- (1) Wedge (Interruption)
Selection 6 0'00" – 0'30"
- (2) Black Spot (Black Dot)
Selection 12 1'10" – Selection 13 0'30"
- (3) Fingerprint
Selection 19 0'00" – 0'30"

4. MECHANISM ASS'Y AND PARTS LIST

4.1. Synthesis

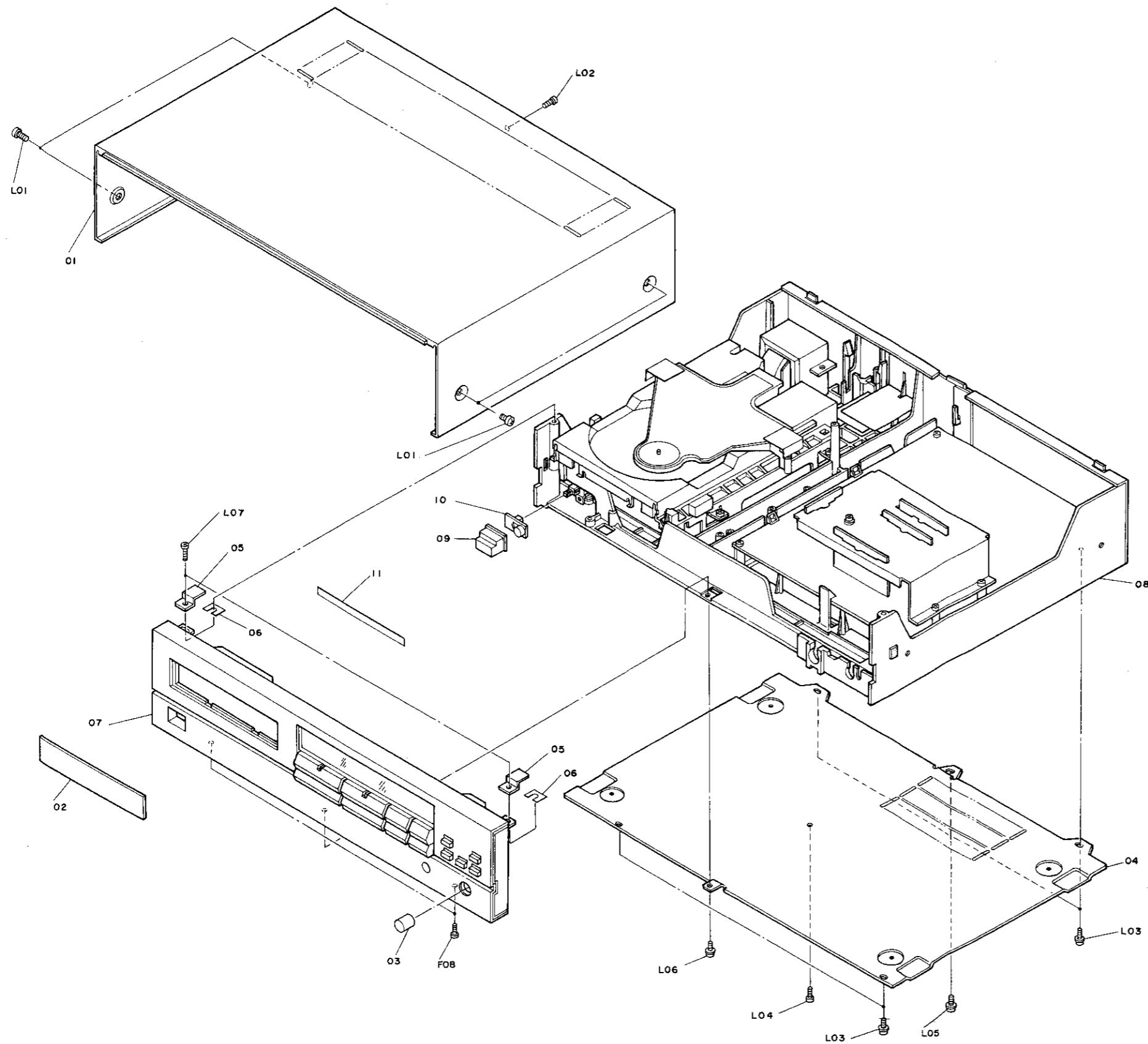

Schematic Ref. No.	Part No.	Description	Q'ty
		Synthesis	
01	CA80511A	Top Cover Ass'y	1
	(0C81483A)	Top Cover	(1)
	(0C81582A)	Vibration Isolating Sheet A	(1)
	(0C81598A)	Top Cover Cushion	(2)
	(0C81652A)	Cushion	(1)
	(0C82350A)	Vibration Isolating Sheet B	(2)
	(0C82352A)	Rubber Cushion	(1)
	(0M04377B)	Caution Label	(1)
02	0C81603A	Disc Tray Cover	1
03	CA80396A	Volume Knob Ass'y	1
04	CA80512A	Bottom Cover Ass'y	1
	(0C81561A)	Bottom Cover	(1)
	(0C81479A)	Leg	(4)
	(0M04377B)	Caution Label	(1)
	(0M04810A)	Shipping Screw Caution Label	(1)
05	0C82351A	Top Cover Support	2
06	0C81651A	Front Panel Spacer	2
07	CA80518A	Front Panel Ass'y (OMS-4)	1
	CA80430A	Front Panel Ass'y (OMS-4A)	1
	CA80510A	Front Panel Ass'y (OMS-4E)	1
	CA80509A	Front Panel Ass'y (OMS-4O)	1
08	CA80524A	Chassis Ass'y (OMS-4A)	1
	CA80525A	Chassis Ass'y (OMS-4E)	1
	CA80528A	Chassis Ass'y (OMS-4O)	1
	CA80527A	Chassis Ass'y (OMS-4(Canada))	1
	CA80528A	Chassis Ass'y (OMS-4(Australia))	1
	CA80529A	Chassis Ass'y (OMS-4(Others))	1
09	0C81515A	Power Switch Knob	1
10	0C81505A	Power Switch Joint	1
11	0C81594A	Adhesive Tape 3×30	1
—	0M04813A	UL Approval Label	1
—	0M05608A	Manufacturing Periodic Seal	1
—	0M04113A	LA Approval Label	1
—	—	CSA Approval Label	1
—	0M04434B	EP Approval Label	1
—	0M04814A	Pass Label	1
—	0M04815A	Serial Number Seal	1
L01	0C81642A	BT4×12⊕Flanged with washer (Black zinc)	4
L02	0C81623A	BT3×18⊕Pan Projected (Black)	1
L03	0E03368A	BT3×12⊕Binding with washer	4
L04	0E00888A	BT3×12⊕Binding	1
L05	0E03391A	BT3×8⊕Binding Projected	1
L06	0E03365A	BT3×8⊕Binding Projected (Black Chromate)	1
L07	0E03399A	BT3×12⊕Countersunk	2
L08	0E00921A	BT3×8⊕Binding (Black Chromate)	2

4.2. Chassis Ass'y

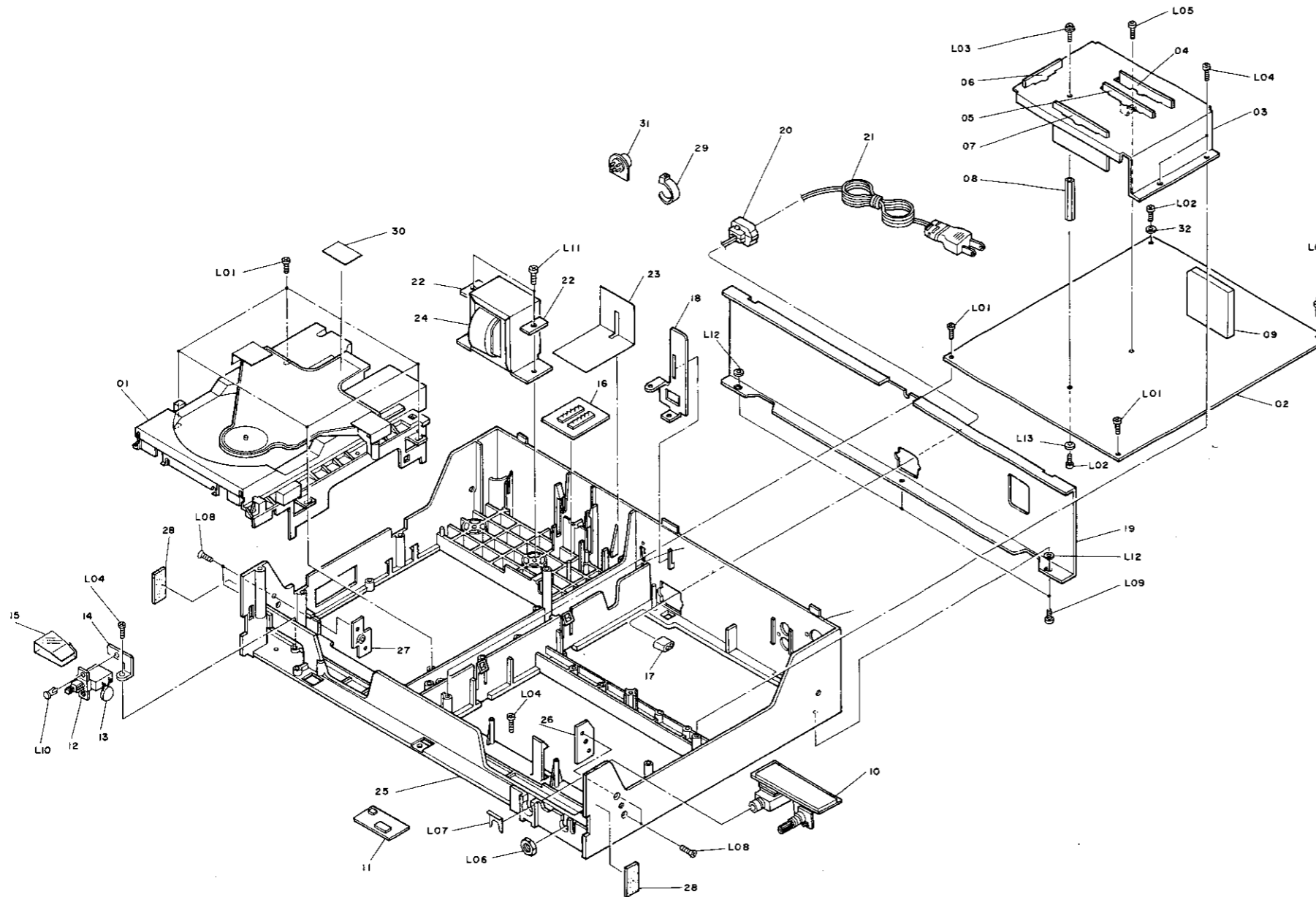

Schematic Ref. No.	Part No.	Description	Q'ty
	CA80524A	Chassis Ass'y (OMS-4A)	
	CA80525A	Chassis Ass'y (OMS-4E)	
	CA80526A	Chassis Ass'y (OMS-40)	
	CA80527A	Chassis Ass'y (OMS-4(Canada))	
	CA80528A	Chassis Ass'y (OMS-4(Australia))	
	CA80529A	Chassis Ass'y (OMS-4(Other))	
01	CA80436A	Disc Mechanism Ass'y	1
02	CA80409A	Main P. C. B. Ass'y	1
03	OC81570A	P. C. B. Holder	1
04	CA80413A	DAC P. C. B. Ass'y	1
05	CA80412A	DF/F P. C. B. Ass'y	1
06	CA80407A	RAM P. C. B. Ass'y	1
07	CA80406A	Signal Process P. C. B. Ass'y	1
08	OC81581A	Stud 60mm	1
09	CA80415A	Analog Filter P. C. B. Ass'y	1
10	CA80410A	Headphone Amp. P. C. B. Ass'y	1
11	CA80514A	Search P. C. B. Ass'y	1
12	OC81890A	Power Switch	1
13	OC82353A	CC 4700pf 400V (M)	1
14	OC81539A	Power Switch Holder	1
15	OC81800A	Power Switch Insulator (OMS-4E)	1
16	CA80416A	Terminal P. C. B. Ass'y	1
17	OC81880A	Ferrite Core	1
18	OC81560A	Bushing Holder	1
19	OC81572A	Rear Panel (OMS-4)	1
	OC81562A	Rear Panel (OMS-4A)	1
	OC81573A	Rear Panel (OMS-4E)	1
	OC81575A	Rear Panel (OMS-40)	1
	OC81574A	Rear Panel (OMS-4(Other))	1
20	OC81472A	Cord Bushing	1
21	OC82300A	Power Cord (OMS-4A & OMS-4 (Canada))	1
	OC82303A	Power Cord (OMS-4E)	1
	OC82301A	Power Cord (OMS-40)	1
	OC82356A	Power Cord (OMS-4(Australia))	1
	OC82302A	Power Cord (OMS-4(Other))	1
22	OC81655A	Transformer Reinforce Plate	2
23	OC81983A	Terminal P. C. B. Insulator (OMS-4A & OMS-4(Canada))	1
24	OC81879A	Power Transformer (OMS-4A & OMS-4(Canada))	1
	OC82298A	Power Transformer (OMS-4E)	1
	OC82297A	Power Transformer (OMS-40)	1
	OC82299A	Power Transformer (OMS-4(Other))	1
25	OC81482A	Chassis	1
26	OC81564A	Top Cover Holder R	1
27	OC81563A	Top Cover Holder L	1
28	OC82385A	Cushion	2
29	OC81471A	Insu-Lock L=94mm	5
30	OM04611A	US Laser Caution Label (OMS-4A)	1
31	OC82355A	Voltage Selector (OMS-4(Other))	1
	OC81519A	Ground Plate	1
	OC81922A	4P Connector Cord	1
	CA80425A	Chassis Wire Ass'y	1
L01	OE03157A	BT3×8ΦBinding with Washer	7
L02	OE03391A	BT3×8ΦBinding Projected	2
L03	OE03415A	M3×8ΦPan(3A)	1
L04	OE00868A	BT3×8ΦBinding	4
L05	OE00888A	BT3×12ΦBinding	1
L06	—	Volume Nut	1
L07	—	Snap Plate	1
L08	OC82416A	M3×8ΦCountersunk	4
L09	OE00921A	BT3×8ΦBinding (Black Chromate)	2
L10	OC81625A	Plastic Rivet	1
L11	OE00924A	BT4×18ΦBinding	2
L12	OC81630A	Washer 3mm Fiber	3
L13	OC81624A	Washer 3.2×8×0.5	1

4.3. Front Panel Ass'y

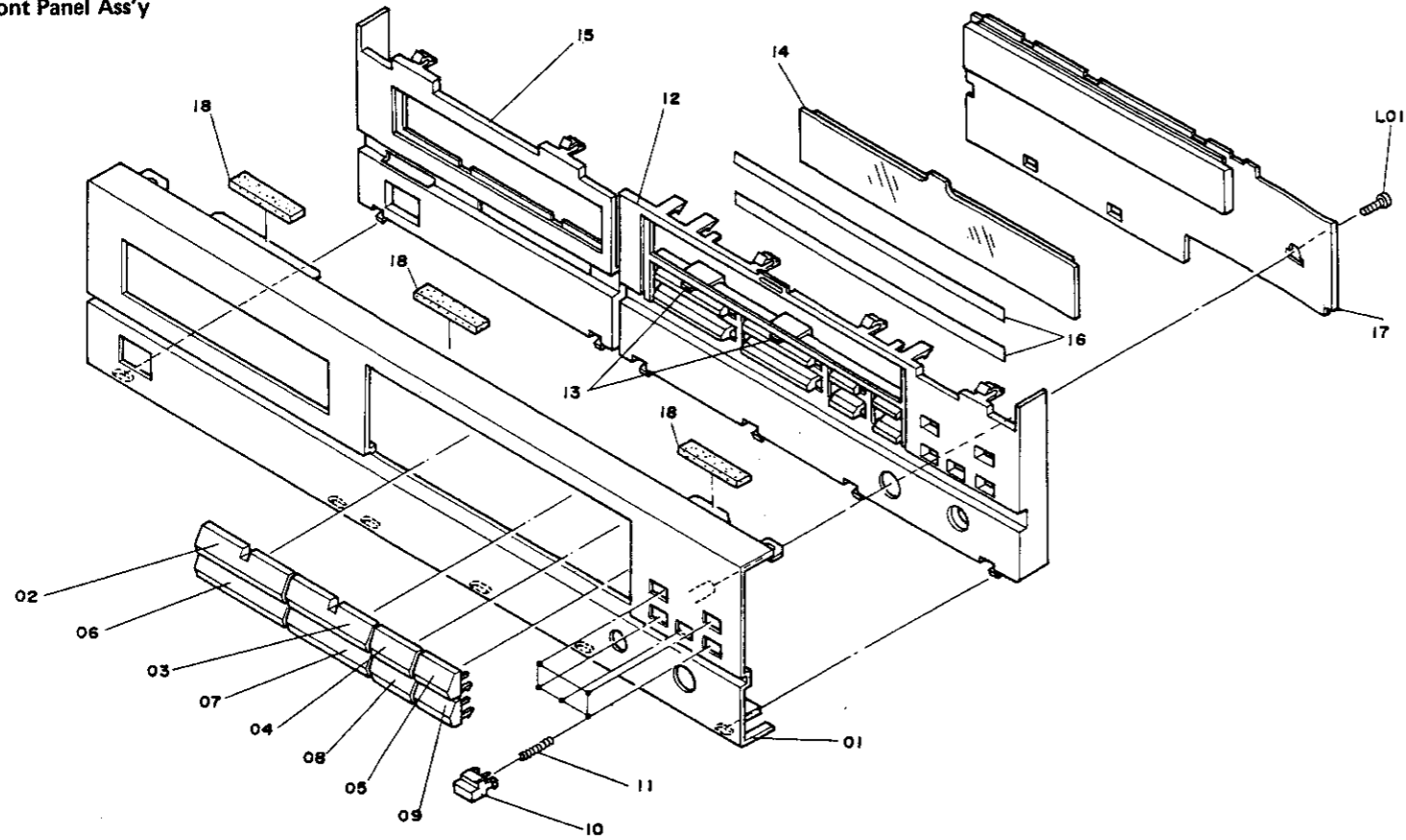

4.4. Top Cover Ass'y

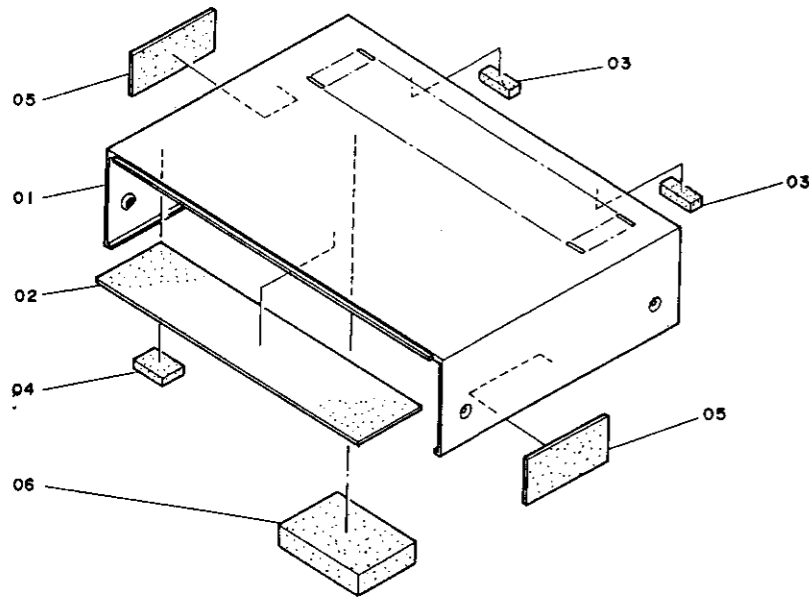

4.5. Bottom Cover Ass'y

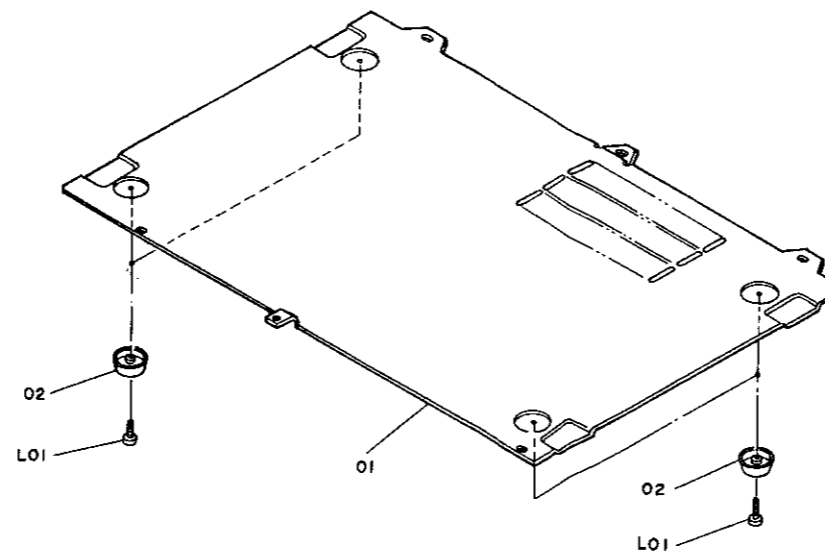

Schematic Ref. No.	Part. No.	Description	Q'ty
	CA80518A	Front Panel Ass'y (OMS-4)	
	CA80430A	Front Panel Ass'y (OMS-4A)	
	CA80510A	Front Panel Ass'y (OMS-4E)	
	CA80509A	Front Panel Ass'y (OMS-40)	
01	0C81650A	Front Panel (OMS-4)	1
	0C81601A	Front Panel (OMS-4A)	1
	0C81806A	Front Panel (OMS-4E)	1
	0C81607A	Front Panel (OMS-40)	1
02	0C81506A	Play Button	1
03	0C81507A	Pause Button	1
04	0C81510A	R. Skip Button	1
05	0C81511A	F. Skip Button	1
06	0C81508A	Eject Button	1
07	0C81509A	Stop Button	1
08	0C81512A	Rev. Button	1
09	0C81513A	F. Fwd. Button	1
10	0C81514A	Push Button	5
11	0C81567A	Button Spring	5
12	0C81502A	Front Escutcheon R	1
13	0C81503A	LED Filter	2
14	0C81602A	Acrylic Cover	1
15	0C81504A	Front Escutcheon L	1
16	0C82354A	Adhesive Tape	2
17	CA80414A	Control & Display P. C. B. Ass'y	1
18	0C81597A	Top Cover Cushion F	3
	0C82388A	Spacer A	1
	0C82389A	Spacer B	1
	0C82390A	Spacer C	1
	0C82391A	Spacer D	1
L01	0E00868A	BT3×8⊕Binding	1
	CA80511A	Top Cover Ass'y	
01	0C81483A	Top Cover	1
02	0C81582A	BS Damper A	1
03	0C81598A	Top Cover Cushion R	2
04	0C81652A	Cushion	1
05	0C82350A	BS Damper B	2
06	0C82352A	Rubber Cushion	1
	CA80512A	Bottom Cover Ass'y	
01	0C81561A	Bottom Cover	1
02	0C81479A	Leg	4
L01	0E00888A	BT3×12⊕Binding	4

4.6. Disc Mechanism Ass'y

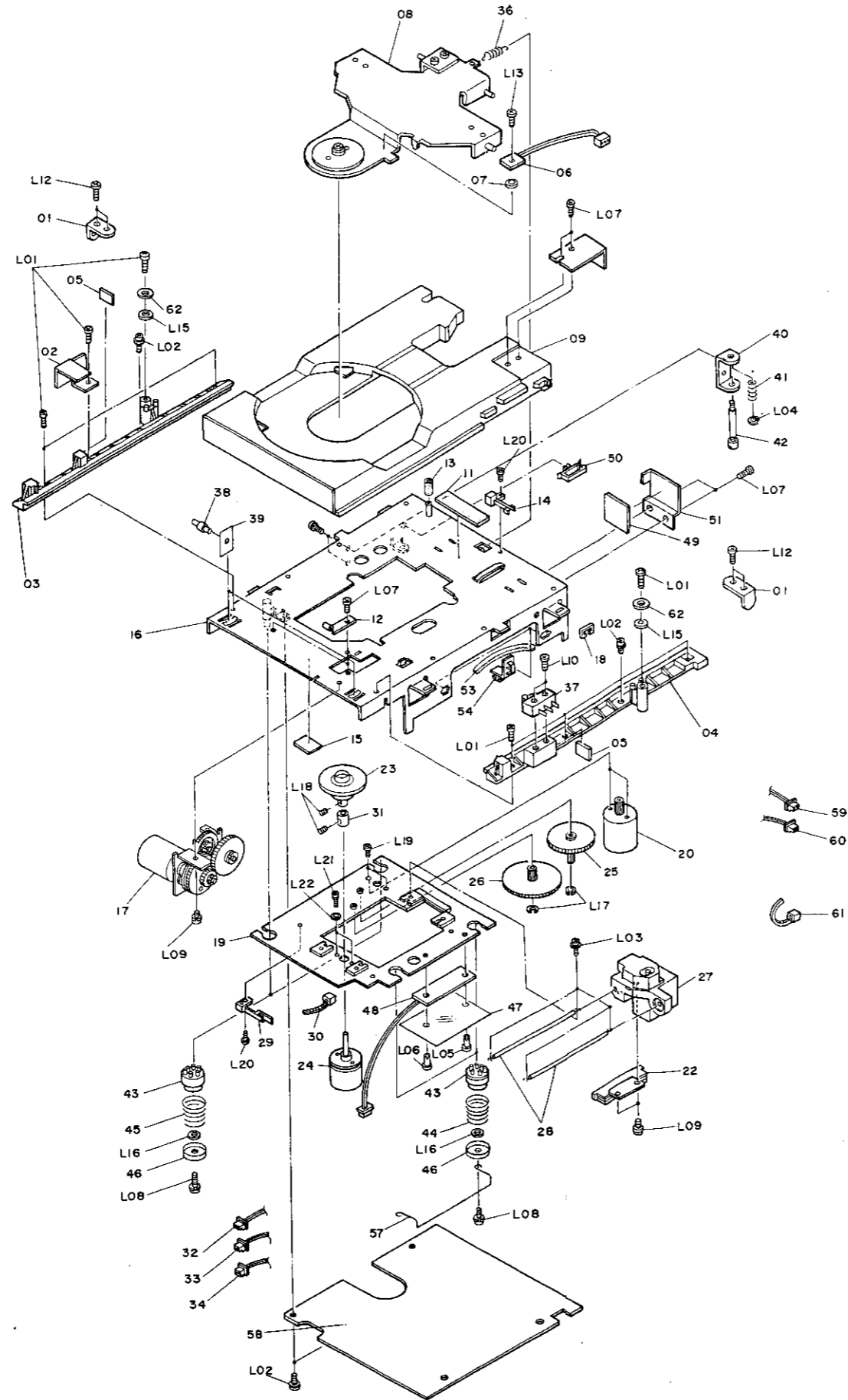

Schematic Ref. No.	Part No.	Description	Q'ty
	CA80436A	Disc Mechanism Ass'y	
01	OC81560A	Chuck Arm Plate	1
02	OC82346A	Disc Tray Guide Plate	1
03	OC81493A	Disc Drawer Guide L	1
04	OC81494A	Disc Drawer Guide R	1
05	OC81589A	Stopper Rubber	2
06	CA80422A	Photo Transistor P. C. B. Ass'y	1
07	OC82349A	Collar	1
08	CA80428A	Chuck Arm Ass'y	1
09	CA80395A	Disk Tray Ass'y	1
10	OC82348A	Disk Tray Plate	1
11	OC81591A	Chuck Cushion	1
12	OC81542A	Disk Support Stopper	2
13	OC81585A	Stopper Cushion	1
14	OC81887A	Leaf Switch MSW1275	1
15	OC81592A	Vibration Isolating Sheet	1
16	CA80399A	Disk Mechanism Chassis Ass'y	1
17	CA80393A	Loading Gear Ass'y	1
18	OC81474A	Wire Clamper	2
19	CA80401A	Sub Chassis B Ass'y	1
20	CA80521A	Feed Motor Ass'y	1
22	CA80391A	Feed Rack Ass'y	1
23	CA80400A	Turntable B Ass'y	1
24	OC81938A	Disc Motor RF-310	1
25	OC81497A	Feed Gear A	1
26	OC81498A	Feed Gear B	1
27	OC81936A	Laser Pickup Ass'y KSS-121B	1
28	OC81535A	Pickup Rail	2
29	OC81888A	Leaf Switch	1
30	OC81660A	Wire Clamper	1
31	OC81558A	Collar	1
32	OC81912A	2P Connector N	1
33	OC81921A	2P Connector Q	1
34	OC81913A	2P Connector E	1
38	OC81557A	Chuck Arm Spring	1
37	OC81886A	Microswitch SS-5GL13	1
38	CA80392A	Roller Ass'y	4
39	OC81543A	Roller Stopper	2
40	OC81544A	Shipping Screw Holder	1
41	OC81538A	Shipping Screw Spring	1
42	OC81545A	Shipping Screw	1
43	OC81536A	Cushion	4
44	OC81536A	Cushion Spring A	4
45	OC81540A	Cushion Spring B	1
46	OC81537A	Cushion Holder	4
47	OC81585A	Insulator	1
48	CA80515A	Photo Diode P. C. B. Ass'y	1
49	OC81588A	Magnet Rubber	1
50	OC82413A	Wire Clamper	1
51	OC82414A	Disc Tray Lock Plate	1
53	OC81475A	Free Bushing 100mm	1
54	OC81473A	P. C. B. Support	2
57	OC81559A	Guide Spring	1
58	CA80405A	Servo P. C. B. Ass'y	1
59	OC81914A	2P Connector G	1
60	OC81915A	2P Connector H	1
61	OC81471A	Insu-Lock L=94mm	6
62	OC82387A	Collar	2
L01	OE00868A	BT3×8@Binding	8
L02	OE03157A	BT3×8@Binding With Washer	4
L03	OC81846A	BT2.6×8@Binding With Washer	6
L04	OE00134A	E-Ring 4mm	1
L05	OC81662A	Plastic Rivet	1
L08	OC81656A	Plastic Rivet 3×8	1
L07	OE03993A	ST2.6×8@Binding	4
L08	OE03416A	M2.6×5@Pan (2A)	6
L09	OC81622A	M2.6×4@Pan (2A)	2
L10	OC81945A	M2×12@Pan	2
L11	OC81624A	Washer	2
L12	OE00792A	BT2.6×6 Pan	6
L13	OE00121A	M2.6×6@Pan	1
L14	OC81948A	Washer 3mm Spring	1
L15	OC82386A	Washer 6×11×1.0(Rubber)	2
L16	OE00071A	Washer 3mm Fiber	4
L17	OC81629A	Washer Plastics2.6×4.6×0.5(Cut)	2
L18	OC81639A	M2×3 Hex Socket Head	2
L19	OC81640A	M2×11.5(4)Cylinder Head	2
L20	OC81940A	M2×6@Pan	2
L21	OC81944A	BT2×8@Pan	2
L22	OC81947A	Washer 2mm Spring	2

4.7. Loading Gear Ass'y

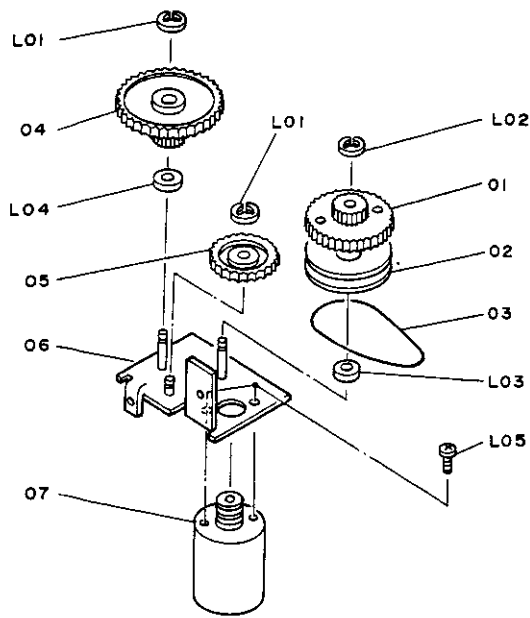

4.8. Chuck Arm Ass'y

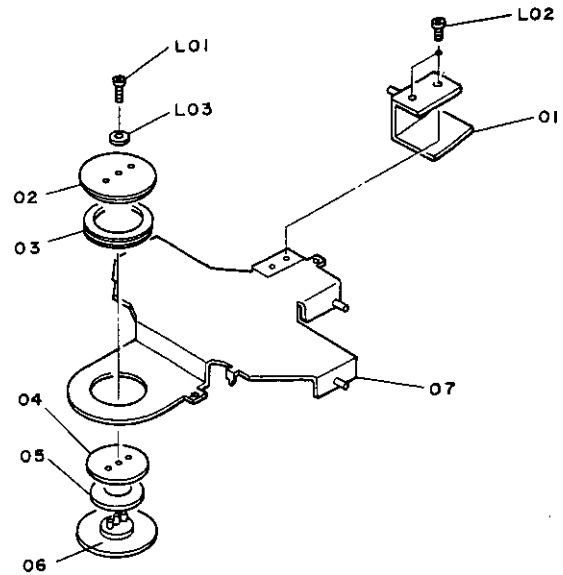

Schematic Ref. No.	Part No.	Description	Q'ty	Schematic Ref. No.	Part No.	Description	Q'ty
	CA80428A	Loading Gear Ass'y		04	0C81534A	Chuck Yoke	1
01	0C81491A	Loading Gear A	1	05	0C81481A	Ring Magnet B	1
02	0C81477A	Loading Pulley	1	06	0C81501A	Magnet Holder B	1
03	0C81478A	Loading Belt	1	07	CA80403A	Chuck Arm Base Ass'y	1
04	0C81484A	Loading Gear B	1	L01	0E03124A	BT2 x 5 Pan	1
05	0C81485A	Loading Gear C	1	L02	0E03393A	ST2.6 x 8 Binding	2
06	CA80397A	Loading Gear Holder Ass'y	1	L03	0C81946A	Washer 2.2 x 5 x 0.3	1
07	CA80523A	Loading Motor Ass'y	1				
L01	0E00181A	E-Ring 3mm	2				
L02	0C81638A	Washer Plastics 4.1 x 6.5 x 0.5 (Cut)	1				
L03	0E03393A	Washer FT 6.2 x 0.13	1				
L04	0C82342A	Washer Plastics 4.1 x 7 x 0.5	1				
L05	0E00622A	M3 x 5 Pan (2A)	2				
	CA80428A	Chuck Arm Ass'y					
01	CA80402A	Chuck Base Ass'y	1				
02	0C81496A	Chuck B	1				
03	0C81590A	Chuck Rubber	1				

5. MOUNTING DIAGRAMS AND PARTS LIST

5.1. Main P.C.B. Ass'y

Notes:

1. Mounting diagram shows a dip side view of the printed circuit board.
2. Diode is 1S2473 unless otherwise specified.
3. Abbreviation for part name:

TR – Transistor, SiD – Silicon Diode, Varicap – Variable Capacitance Diode
RK – Carbon Resistor, RM – Metal Film Resistor, RF – Fail Safe Type Resistor
CE – Electrolytic Capacitor, CM – Mylar Capacitor, CC – Ceramic Capacitor,
CT- Tantalume Capacitor, C- Mica Capacitor
CF – Film Capacitor
CSP – Polystyrene Capacitor
CMM – Metallized Mylar Capacitor

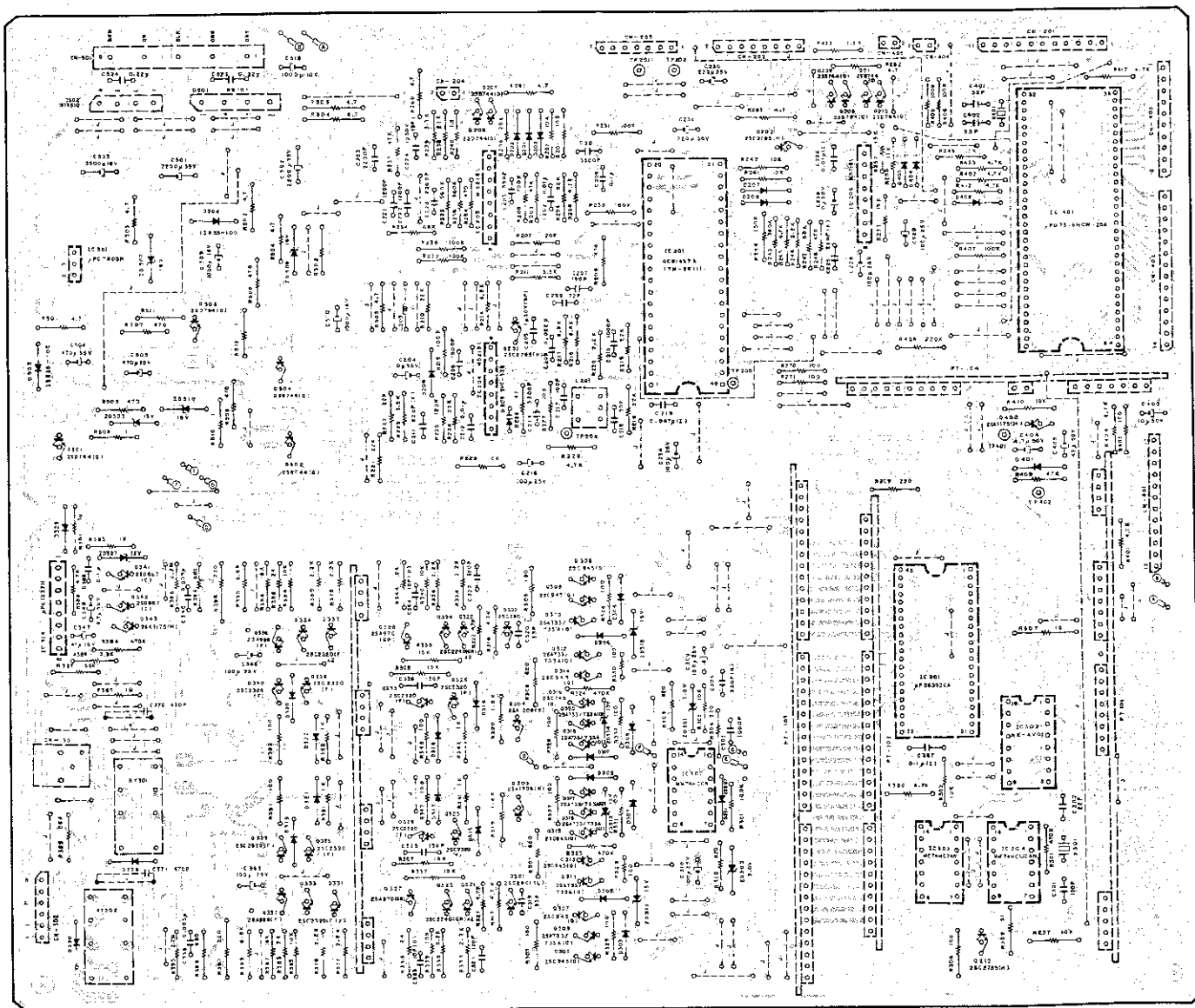

Schematic Ref. No.	Part No.	Description	Schematic Ref. No.	Part No.	Description	Schematic Ref. No.	Part No.	Description
	CA80409A	Main P. C. B. Ass'y	R201, 320	0B01679A	RK 100 1/4W J	R393, 394	0B05794A	RK 680 1/4W J
IC201	OC81457A	IC YM-3811	325, 326			R395, 396	0B05671A	RK 2.2M 1/4W J
IC204, 205	OC81695A	IC M5218L	327, 328			R397, 398	0B20397A	RK 220 1/2W F
206			330, 331			R399, 397	0B05508A	RK 56K 1/4W J
IC301	OC81710A	IC μ PD6352CA	332, 347			R408	0B05625A	RK 220K 1/4W J
IC302	OC81708A	IC HE-AV01	348, 391			R432	0B05698A	RK 1.5K 1/4W J
IC303	OC81706A	IC MM74HC74N	392, 3D8			R501, 504	0B09321A	RF 4.7 1/4W J
IC304	OC82288A	IC MM74HCL104N	403			R505, 506	OC81715A	RF 470 1/4W J
IC307	OC81707A	IC MM74HC04N	R202, 227	0B01888A	RK 10K 1/4W J	507, 508		
IC314	OC81699A	IC UPC1237H	228, 241			R509, 510	0B05695A	RK 1 1/4W J
IC401	OC81705A	IC μ PD7516HCW-256	242, 257			511, 512		
Q201, 202	OC81667A	S-TR 2SC2785	302, 303			C201, 214	0B01914A	CM 3300PF 50V J
Q206, 208	OC81676A	S-TR 2SD794Q	339, 340			C202, 212	0B05681A	CM 0.01UF 50V J
210, 501			383, 384			C203	0B41738A	CC 390PF 50V J
503			410			C204, 238	0B40289A	CE 10UF 50V
Q207, 209	OC81664A	S-TR 2SD744Q	R203, 237	0B05641A	RK 47K 1/4W J	403		
211, 502			409			C205, 224	0B09157A	CE 1UF 50V (BP)
504			R204	0B05668A	RK 82K 1/4W J	C206, 368	0B01780A	CM 0.1UF 50V J
Q301, 302	OC81674A	S-TR 2SC2901L	R205, 215	0B01889A	RK 100K 1/4W J	C207, 218	0B41743A	CC 150PF 50V J
Q303, 304	OC81670A	S-TR 2SA1206K	231, 232			301		
Q305, 306	0B06251A	S-TR 2SC945Q	235, 3C1			C208	0B05653A	CM 1500PF 50V J
307, 308			405, 406			C209	0B05582A	CM 0.022UF 50V J
313, 314			407			C210, 303	0B05550A	CF 1000PF 50V J
315, 316			R206, 207	0B09509A	RK 20K 1/4W J	C216, 228	0B01272A	CE 100UF 25V
Q309, 310	0B06013A	S-TR 2SA733	R208, 229	0B01846A	RK 4.7K 1/4W J	229, 234		
311, 312			245, 317			C217	0B41742A	CC 100PF 50V J
317, 318			318, 321			C219	0B09387A	CC 0.047UF 50V Z
319, 320			322, 3B8			C220, 223	0B01802A	CM 2200PF 50V J
Q321, 322	0B10078A	S-TR 2SC2240GR	3D0, 401			C226	0B09290A	CC 0.01UF 50V Z
323, 324			402, 404			C230, 231	0B05831A	CE 220UF 35V
Q325, 326	OC80672A	S-TR 2SC2320F	412, 417			C239, 302	0B09279A	CC 22PF 50V J
329, 330			433			C304	0B41756A	C 330PF 50V K
331, 332			R209, 248	0B05596A	RK 470 1/4W J	C309, 310	0B40429A	CE 100PF 25V (LN)
333, 334			264			365, 366		
335, 336			R210, 218	0B05615A	RK 22K 1/4W J	C319, 320	0B41758A	C 33PF 100V J
339, 340			219, 221			C321, 322	0B41759A	C 120PF 100V J
Q327, 328	0B06180A	S-TR 2SA970GR	222, 224			C325, 326	0B51754A	CSP 150P 15V J
Q337, 338	OC81669A	S-TR 2SA999F	238			C339, 340	0B41753A	CSP 3000P 16V J
Q341, 342	OC81675A	S-TR 2SD667C	R211, 223	0B01681A	RK 3.3K 1/4W J	C347	0B01403A	CE 47UF 18V
Q343, 402	OC81666A	S-TR 2SA1175	239			C348, 404	0B40201A	CE 4.7UF 50V
D201, 202	0B12248A	SI-D 1S2473	R214, 216	0B01682A	RK 6.8K 1/4W J	C363, 364	0B41757A	C 10PF 100V D
203, 204			217, 389			C367	0B09292A	CC 0.1UF 50V Z
207, 208			390			C370, 371	0B41196A	CSP 470P 160V
303, 304			R220, 246	0B05622A	RK 2.2K 1/4W J	C401, 402	0B41740A	CC 33PF 50V J
307, 308			333, 334			C405	0B40119A	CE 47UF 50V
309, 310			335, 336			C501, 502	0B82358A	CE 2200UF 35V
315, 316			377, 378			C503	0B40235A	CE 3300UF 16V
317, 318			379, 380			C504, 505	0B40107A	CE 470UF 35V LN
319, 320			R225	0B05621A	RK 120K 1/4W J	C509, 510	OC40082A	CE 1000UF 16V
321, 322			R226	0B01706A	RK 47 1/4W J	519		
328, 329			R230	0B05640A	RK 180K 1/4W J	C523, 524	OC82305A	CF 0.22UF 50V J
330, 401			R233, 236	0B05784A	RK 560K 1/4W J			
402, 403			R234, 247	0B05692A	RK 68K 1/4W J			
404			R243	0B20400A	RK 360K 1/4W J			
D209	OC81677A	Varicap SVC333	R244	0B05626A	RK 150K 1/4W J			
D301, 302	OC81667A	ZD RD3.0EB1 (A)	R249, 250	0B09334A	RK 11K 1/4W J			
D305, 306	0B12248A	SI-D 1S2473	R251, 252	0B01683A	RK 15K 1/4W J			
D311, 312	0B12176A	ZD RD13JB1	R260, 261	0B09671A	RK 4.7 1/4W J			
313, 314			262, 263					
D327	OC81689A	ZD RD13EB1 (A)	3D3, 3D4					
D3S1	OC82294A	SI-D 1SS97	R270, 271	0B01713A	RK 33 1/4W J			
D501	0B06183A	SI-D RB151	R301, 323	0B01684A	RK 470K 1/4W J			
D502	0B1661A	SI-D S1VB10	324, 3B4					
D503, 504	0B12365A	SI-D 1SR35-100	R304	0B05930A	RF 220 1/4W J			
D505, 506	OC81690A	ZD RD16EB1 (A)	R305, 306	0B05795A	RK 150 1/4W J			
507, 508			R307, 308	0B09882A	RK 620 1/4W J			
X301	OC81884A	XTAL 8.6436MHz	R309, 310	0B24128A	RF 820 1/4W J			
X401	OC81883A	Ceramic Resonator 4MHz	R319, 320	0B05614A	RK 1.8K 1/4W J			
3B5	0B05776A	RK 1M 1/4W J	R337, 338	0B01683A	RK 15K 1/4W J			
3B6	0B05675A	RK 3.9K 1/4W J	3C7, 3C8					
R3C9	0B05930A	RF 220 1/4W J	R341, 342	0B01857A	RK 1.0K 1/4W J			
R3D1	0B05936A	RF 10 1/4W J	381, 382					
R3D9	0B20403A	RK 51 1/4W J	383					
RY301, 302	OC81889A	Relay RKT-12	R343, 344	0B20402A	RK 24 1/4W J			
			385, 386					
			R387, 388	0B20399A	RK 16K 1/4W J			

5.2. Servo P.C.B. Ass'y

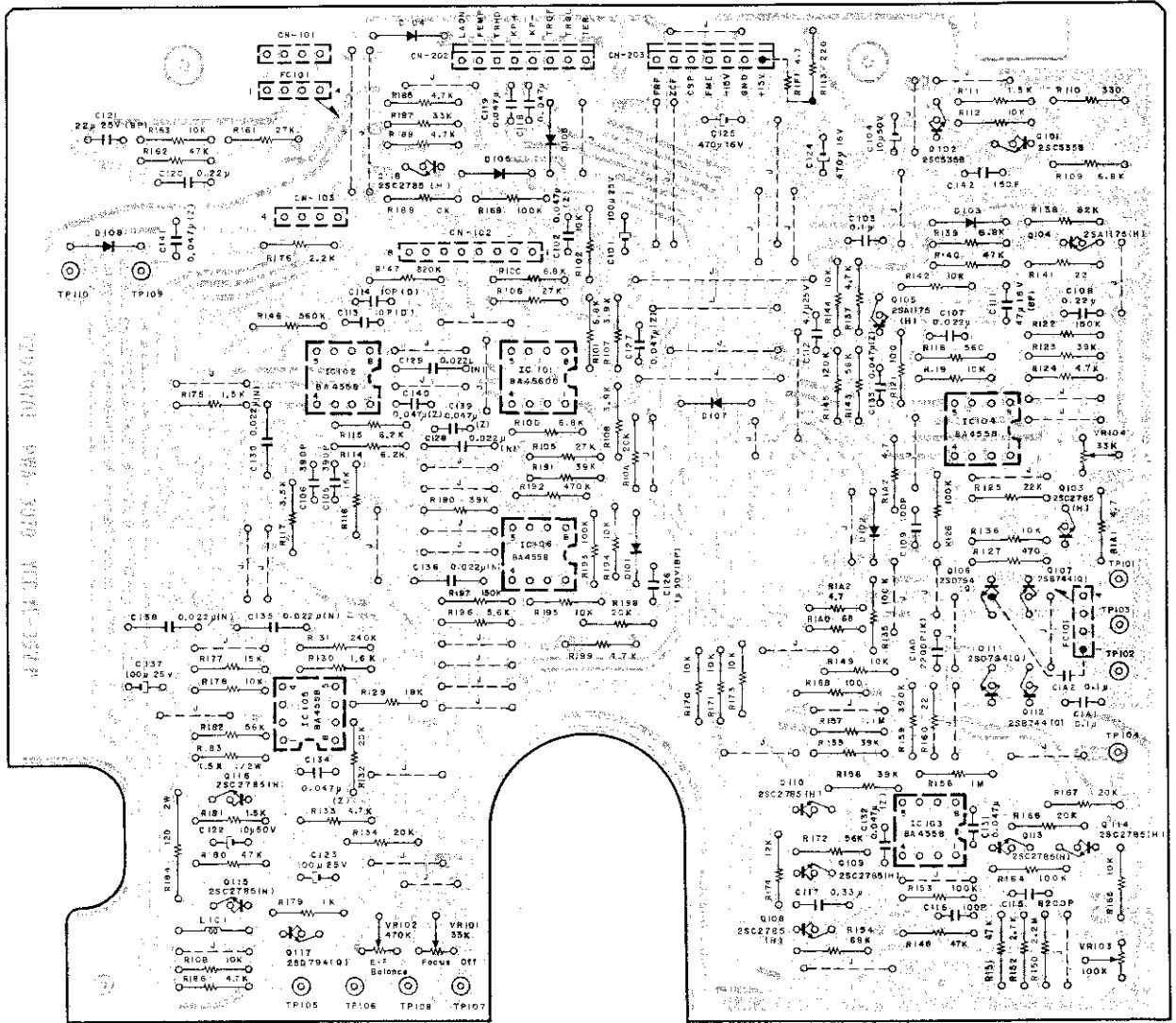

Schematic Ref. No.	Part No.	Description	Schematic Ref. No.	Part No.	Description
	CA80405A	Servo P. C. B. Ass'y	R145	OB05621A	RK 120K 1/4W J
IC101	OB11277A	IC BA4560-D	R147	OB09320A	RK 820K 1/4W J
IC102, 103	OB11266A	IC BA4558	R150	OB05671A	RK 2.2M 1/4W J
104, 105			R152	OB05629A	RK 2.7K 1/4W J
106			R154	OB05692A	RK 68K 1/4W J
Q101, 102	OC81671A	S TR 2SC535B	R156	OB05776A	RK 1M 1/4W J
Q103, 108	OC81667A	S TR 2SC2785 H	R157	OB05691A	RK 1.1M 1/4W J
109, 110			R159	OB05676A	RK 390K 1/4W J
113, 114			R176	OB05622A	RK 2.2K 1/4W J
115, 116			R179	OB01857A	RK 1K 1/4W J
118			R183	OB05698A	RK 1.5K 1/4W J
Q104, 105	OC81666A	S TR 2SA1175 H	R184	OC81717A	RM 120 1/4W J
Q106, 111	OC81676A	S TR 2SD794 Q	R187	OB05509A	RK 33K 1/4W J
117			R192	OB01884A	RK 470K 1/4W J
Q107, 112	OC81664A	S TR 2SB744 Q	R196	OB01887A	RK 5.6K 1/4W J
D101, 102	OB12248A	SI-D 1S2473	C101, 123	OB01272A	CE 100UF 25V
103, 104			1A0		
105, 106			C102, 131	OB09387A	CC 0.047UF 50V Z
107, 108A			132, 133		
VR101	OC81789A	Semi VR 33K	134		
VR102	OC81790A	Semi VR 470K	C103, 1A1	OB01780A	CM 0.1UF 50V J
VR103	OC81791A	Semi VR 100K	C104, 122	OB40289A	CE 10UF 50V
VR104	OC81787A	Semi VR 33K	C105, 106	OB41738A	CC 390PF 50V J
W202	OC81919A	8P Connector Cord	C107	OB05582A	CM 0.022UF 50V J
W203	OC81918A	7P Connector Cord	C113, 114	OB09277A	CC 10PF 50V D
R1A1, 1A2	OB09671A	RK 4.7 1/4W J	C115	OB05814A	CM 8200PF 50V J
L101	OC81880A	Coll 10μH (K)	C116	OB41735A	CC 100PF 50V J
R10A, 198	OB09509A	RK 20K 1/4W J	C119	OB05796A	CM 0.047UF 50V J
1A0	OB01704A	RK 68 1/4W J	C128, 129	OC81836A	CC 0.022UF 16V N
R101, 109	OB01882A	RK 6.8K 1/4W J	130, 135		
10C, 10D			136, 138		
139					
R102, 10B	OB01888A	RK 10K 1/4W J			
112, 119					
R105, 106	OB05743A	RK 27K 1/4W J			
161					
R107, 108	OB05675A	RK 3.9K 1/4W J			
R110	OB05577A	RK 3.30 1/4W J			
R111, 175	OB05698A	RK 1.5K 1/4W J			
181					
R113	OB01933A	RK 220 1/4W J			
R114, 115	OB09271A	RK 6.2K 1/4W J			
R116, 177	OB01683A	RK 15K 1/4W J			
R117	OB01681A	RK 3.3K 1/4W J			
R118, 146	OB05575A	RK 560 1/4W J			
R121	OB01679A	RK 100 1/4W J			
R122, 197	OB05626A	RK 150K 1/4W J			
R123, 155	OB01854A	RK 39K 1/4W J			
158, 190					
191					
R124, 133	OB01846A	RK 4.7K 1/4W J			
137, 185					
186, 188					
199					
R125	OB05615A	RK 22K 1/4W J			
R126, 193	OB01889A	RK 100K 1/4W J			
R127	OB05576A	RK 470 1/4W J			
R129	OB05560A	RK 18K 1/4W J			
R130	OB09565A	RK 1.6K 1/4W J			
R131	OB09483A	RK 240K 1/4W J			
R132, 134	OB09509A	RK 20K 1/4W J			
166, 167					
R135, 153	OB01889A	RK 100K 1/4W J			
164, 168					
169					
R136, 142	OB01888A	RK 10K 1/4W J			
144, 149					
163, 166					
170, 171					
173, 178					
189, 194					
195					
R138	OB05668A	RK 82K 1/4W J			
R140, 148	OB05641A	RK 47K 1/4W J			
151, 162					
180					
R141, 160	OB05579A	RK 22K 1/4W J			
R143, 172	OB05508A	RK 56K 1/4W J			
182					

5.3. Search P.C.B. Ass'y

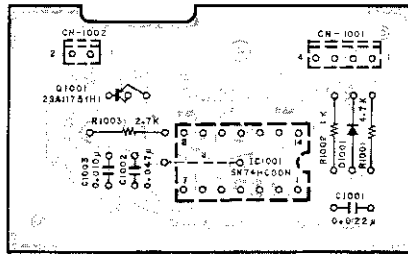

5.4. Control & Display P.C.B. Ass'y

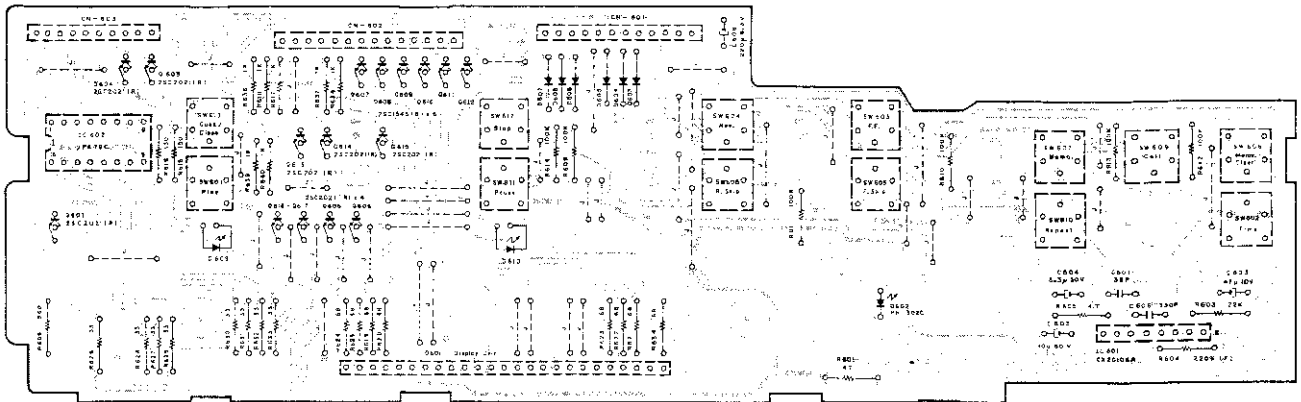

Schematic Ref. No.	Part No.	Description
	CA80514A	Search P. C. B. Ass'y
IC1001	0C81693A	IC SN74HC00N
Q1001	0C81666A	S-TR 2SA1175 H
D1001	0B12248A	SI-D 1S-2473
R1001	0B01846A	RK 4.7K 1/4W J
R1002	0B01857A	RK 1K 1/4W J
R1003	0B05629A	RK 2.7K 1/4W J
C1001	0B05682A	CM 0.022UF 50V J
C1002	0B09387A	CC 0.047UF 50V Z
C1003	0B05681A	CM 0.010UF 50VJ

Schematic Ref. No.	Part No.	Description
	CA80414A	Control & Display P. C. B. Ass'y
Q801, 803, 804	0C81668A	S-TR 2SC2021 R
805, 806		
813, 814		
815, 816		
817		
Q807, 808	0C82293A	S-TR 2SC1545B
809, 810		
811, 812		
D803, 804	0B12248A	SI-D 1S2473
805, 806		
807, 808		
R801	0B01706A	RK 47 1/4W J
R803	0B05615A	RK 22K 1/4W J
R805	0B09671A	RK 4.7K 1/4W J
R806	0B05575A	RK 560 1/4W J
R809, 810	0B01889A	RK 100K 1/4W J
811, 812		
813, 814		
R815, 816	0B05795A	RK 150 1/4W J
R817, 818	0B01857A	RK 1K 1/4W J
836, 837		
838, 839		
840		
R819, 820	0B01704A	RK 68 1/4W J
821, 822		
823, 824		
825, 834		
R826, 827	0B01713A	RK 33 1/4W J
828, 829		
830, 831		
832, 833		
S802, 803	0C81885A	Tact SW
804, 805		
806, 807		
808, 809		
810, 811		
812, 813		

5.5. SIGNAL Process P.C.B. Ass'y

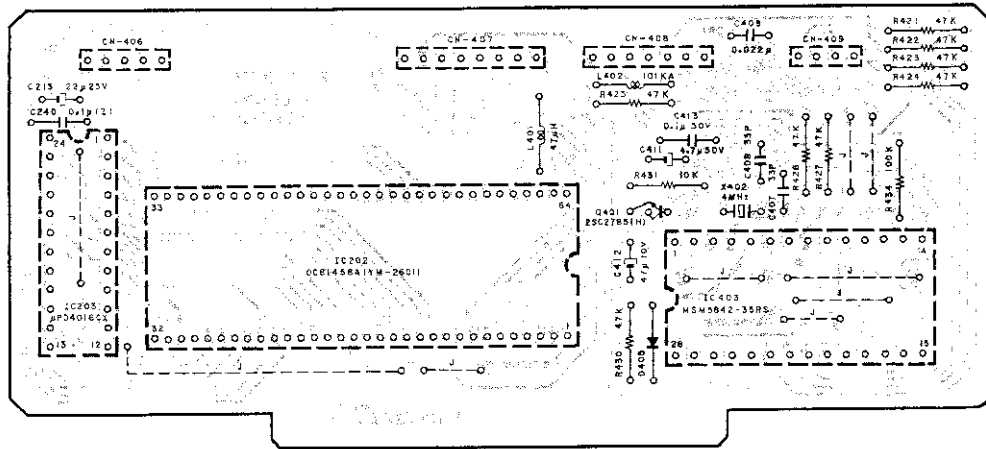

5.6. D F/F P.C.B. Ass'y

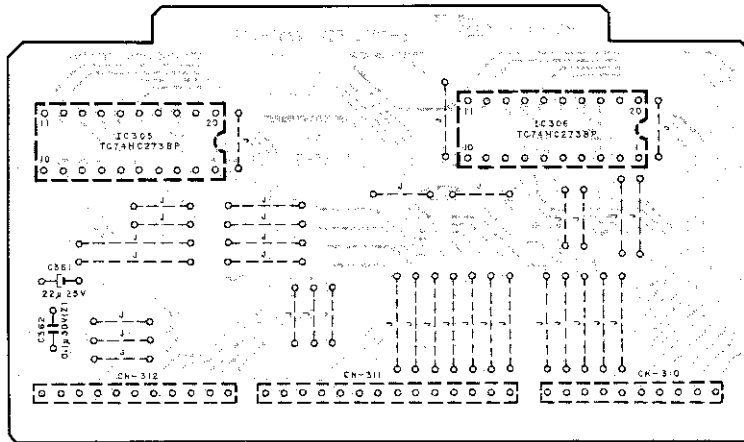

Schematic Ref. No.	Part No.	Description	Schematic Ref. No.	Part No.	Description
	CA80406A	Signal Process Ass'y		CA80412A	D F/F P. C. B. Ass'y
IC202	OC81458A	IC YM-2601	IC305, 306	OC82292A	TC 74HC 273P
IC203	OC81709A	IC UP04016CX	C361	OB40221A	CE 22UF 25V
IC403	OC81702A	IC MSM5842-35RS	C362	OB09292A	CC 0.1μF 50V Z
L401, 402	OC82332A	Coil 100μH (K)			
Q401	OC81667A	S-TR 2SC2785 H			
D405	OB12248A	SI-D 1S2473			
R421, 422	OB01706A	RK 47K 1/4W J			
423, 424					
425, 426					
427, 430					
R431	OB01888A	RK 10K 1/4W J			
R434	OB01889A	RK 100K 1/4W J			
C362, 413	OB09292A	CC 0.1UF 50V Z			
X402	OC81883A	Ceramic Resonator 4MHz			
C407, 408	OB41073A	CC 33PF 50V K			
C409	OB05582A	CM 0.022μF 50V J			
C411	OB40201A	CE 4.7UF 50V			
C412	OB40441A	CE 47UF 10V			

5.7. DAC P.C.B. Ass'y

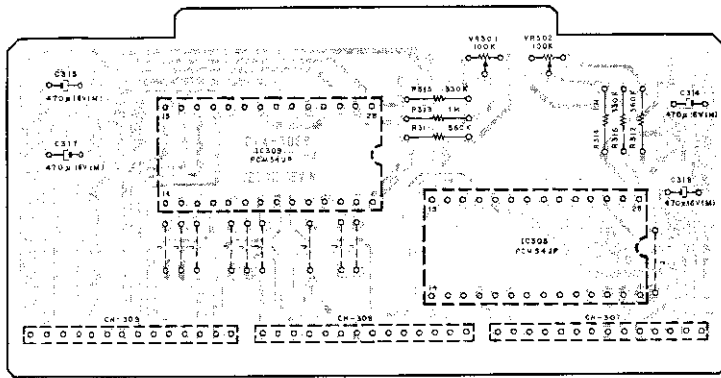

Schematic Ref. No.	Part No.	Description
IC308, 309 VR301, 302 R311, 312 R313, 314 R315, 316 C313, 314 317, 318	CA80413A OC82291A OC81788A OB05784A OB05776A OB05627A OB40437A	DAC P. C. B. Ass'y IC PCM54JP Semi VR 100K RK 560K 1/4W J RK 1M 1/4W J RK 330K 1/4W J CE 470µ 16V(LN)
IC402 R413, 414 415, 416 R428 C406	CA80407A OC81709A OB01848A OB05641A OB40221A	RAM P. C. B. Ass'y IC UPD4016CX RK 4.7K 1/4W J RK 47K 1/4W J CE 22UF 25V
IC310, 311 R345, 346 R351, 352 353, 354 359, 360 365, 366 367, 368 373, 374 R349, 350 363, 364 R355, 356 R357, 358 371, 372 R361, 362 375, 376 R369, 370	CA80415A OB11278A OC81718A OC81719A OB05577A OC81722A OB01888A OB09795A OC81721A	Analog Filter P. C. B. Ass'y IC NJM 5532D RM 3.6K 1/4W F RM 10K 1/4W F RK 330 1/4W J RK 3.9K 1/3W G RK 10K 1/4W J RM 5.1K 1/4W F RK 1.2K 1/3W G

5.8. RAM P.C.B Ass'y

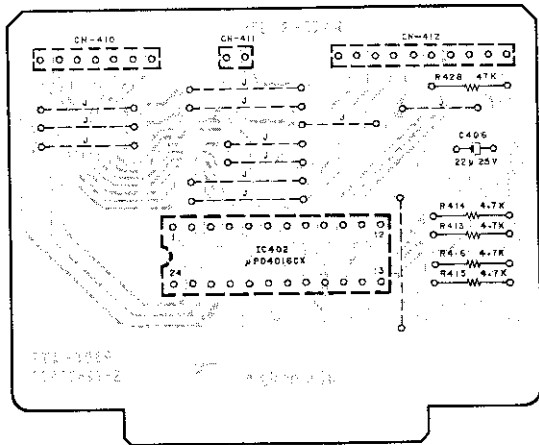

5.9. Analog Filter P.C.B. Ass'y

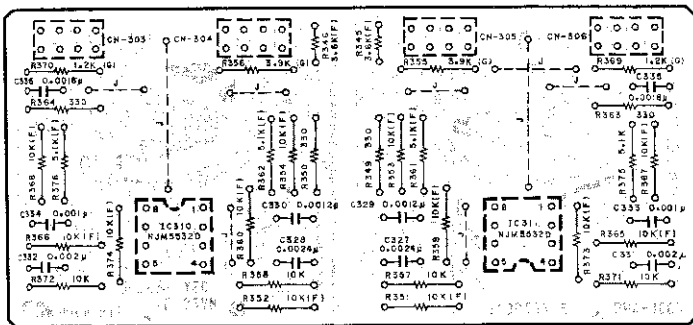

5.10. Headphone Amp P.C.B. Ass'y

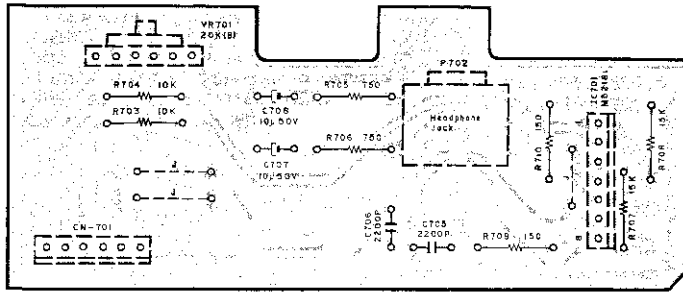

5.11. Terminal P.C.B. Ass'y

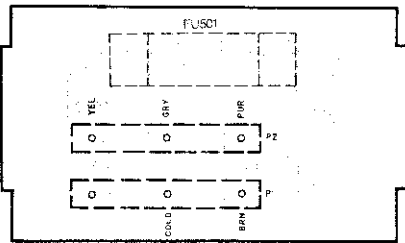

5.12. Photo Transistor P.C.B. Ass'y

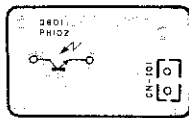

5.13. Photo Diode P.C.B. Ass'y

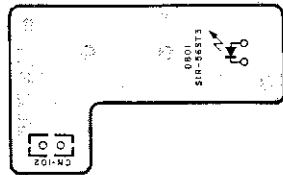

Schematic Ref. No.	Part No.	Description
	CA80410A	Headphone P. C. B. Ass'y
IC901	OC81695A	IC M5218 L
VR901	OC81786A	VR 20KA
R901, 902	OB05936A	RF 22 1/4W J
R903, 904	OB01888A	RK 10K 1/4W J
R905, 906	OB01683A	RK 15K 1/4W J
R907, 908	OB09924A	RK 750 1/4W J
R909, 910	OB05795A	RK 150 1/4W J
C905, 906	OB41233A	CP 2200pF 100V J
C907, 908	OB040289A	CE 10UF 50V
P901	OC81891A	Headphone Jack
	CA80416A	Terminal P. C. B. Ass'y
FU501	OC81902A	3P Terminal ②
	—	Terminal P. C. B.
	OC82415A	Fuse 630mA 250V (OMS-4E)
	OC82412A	Fuse 1A 250V (OMS-4/4A/40)
	CA80422A	Photo Transistor P. C. B. Ass'y
TR801	OC81680A	Photo TR PH-102
	OC81915A	2P Connector Cord
	—	Photo Transistor P. C. B.
	CA80515A	Photo Diode P. C. B. Ass'y
D801	OC82337A	LED SIR-56ST3
	OC81926A	2P Post
	—	Photo Diode P. C. B.

6. IC BLOCK DIAGRAM

IC201 Terminal Functions

Terminal number	Terminal code	I/O	Outline of functions
1	VDD	I	+5V power supply terminal
2 3	VCOX VCOI	0 I	The LC resonance circuit is connected between these terminals. These terminals are used for the VCO clock oscillation (average 8.6436MHz).
4	PCO	0	This is the VCO clock control output terminal. This sets the VCO clock oscillation circuit so that the frequency increases when the average DC voltage between these terminals is high.
5 20	VCC VSS	I I	These are the grounding terminals.
6 7	<u>EFMX</u> EFMX	0 0	Connect to the EFM signal slice level control circuit. This is the amplification-limited EFM signal output terminal. $8 > 7$. The gain of $7 > 6$ is 15.
8	EFMI	I	EFMI signal (1 – 2 VPP) into this terminal
9	SYEQ	0	This is the monitor output terminal that gives a "H" level signal when the synchronization signal of the EFM signal and the synchronization signal of the internal counter correspond.
10 11	DM + DM -	0 0	These are the DISC Motor output terminals, connected to the disc motor driver circuit. It is not possible for both terminals to register "H" simultaneously.
12	FCS	0	This is the focusing output terminal.
13	<u>FZC</u>	I +	Based on the focus error signal, an "L" signal will be input when the focus point is reached.
14	FRF	I	An "H" signal will be entered into this terminal when reflected light is received.
15	H \bar{E}	I	The EFM envelope signal (amplitude logic level) is entered into this terminal.
16	TER	I	The tracking error signal (amplitude logic level) is entered into this terminal.
17	<u>TEST</u>	I +	This test terminal is to be grounded, and contains pull-up resistors.
34	TCL	I +	This test terminal is ungrounded, and contains pull-up resistors.
18	TROF	0	This is the output terminal that switches off the tracking signal of the tracking servo circuit.
19	TRGL	0	This output terminal minimizes the gain of the tracking servo circuit.
20	TRHD	0	This output terminal holds the tracking error signal of the tracking servo circuit while KP+ or KP- (see below) are being output.
22 23	KP + KP -	0 0	These output terminals are for the track kick function, and are connected to the tracking servo circuit.
24	FEOF	0	This output terminal is used to switch off the input signal of the feed servo circuit.
25 26	FEM + FEM -	0 0	This request output terminal is connected to MPU, and requests that connected to the feed servo circuit.
27	WQ	0	This request output terminal is connected to MPU, and requests that data be sent from SVC > MPU.

Terminal number	Terminal code	I/O	Outline of functions
28	R/W	0	This output terminal is connected to MPU, and is used for the switching of the data transmission mode. When R/W = "L", data is transmitted from SVC > MPU, and when R/W = "H", data is transmitted from MPU > SVC.
29	DOUT	0	This data output terminal is connected to MPU. When R/W = "L", data can be transmitted from SVC > MPU according to the SCK clock input.
30	DIN	1	This data input terminal is connected to MPU. When R/W = "H", data is transmitted from MPU > SVC according to the SC key clock input.
31	SCK	1	Connected to MPU, this terminal is for the clock input, required for data transmission.
32	XFSY	1	This is the frame synchronization signal (7.35kHz) input terminal, connected to the SCG output.
33	$\phi 4$	1	This is the crystal clock (4.321MHz) input terminal, connected to the SGP output.
35	RCX	1 +	Connected to MPU, this terminal is for the clock input, required for the subcode transmission. It is disconnected when not being used.
36	VFSY	0	This is the VCO frame synchronization signal (average 7.35kHz) output terminal, connected to MPU. Detecting the change from "H" > "L", this can be used as a request signal, requesting that the subcode be transmitted from SVC > MPU.
37	SUB	0	This is the subcode output terminal, connected MPU. The subcode can be transmitted from SVC > MPU according to the \overline{RCK} clock input.
38	DSY	0	This is the synchronization signal output terminal for the serial signals (see below), connected to the SGP input.
39	DATA	0	This is the serial signal output terminal for the 8 bit EFM demodulation signals and the 5 bit control signals, connected to the SGP input.
40	CK	0	This is the VCO clock (average 4.3218MHz) output terminal, connected to the SGP input.

**IC MOS YM3811
IC201**

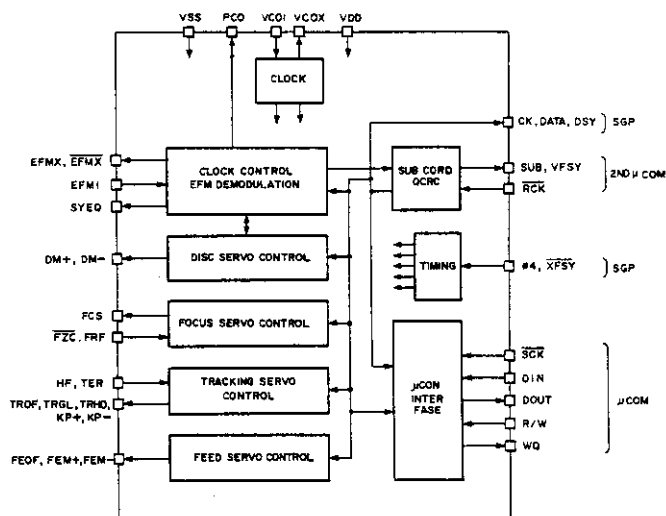

4. IC202 Terminal Functions

Terminal number	Terminal code	I/O	Outline of functions
1 17	VSS VSS	I I	These are the grounding terminals.
2 3 7 8	$\overline{\text{TEST 1}}$ $\overline{\text{TEST 2}}$ $\overline{\text{TEST 3}}$ TCL	I+ I+ I+ I+	These test terminals are ungrounded, and contain pull-up resistors.
4	CK	I	This is the VCO clock (average 4.3218MHz) input terminal, connected to the SVC output.
5	DATA	I	This is the serial signal input terminal for the 8 bit EFM demodulation signals and the 5 bit control signals, connected to the SVC output.
6	DSY	I	This is the synchronization signal input terminal for the serial signals (see above), connected to the SVC output.
9	$\phi 4$	O	This is the crystal clock (4.3218MHz) output terminal, connected to the SVC input.
10	$\overline{\text{XFSY}}$	I/O	This is the frame synchronization signals (7.35kHz) output terminal, connected to the SVC input. (During test operations, the synchronization can be resynchronized by setting this terminal to the "L level".)
11 12 13 14 15 16 18 19 20 21 24	A0 A1 A2 A3 A4 A5 A6 A7 A8 A9 A10	O O O O O O O O O O O	These are the address output terminals, connected to the RAM address terminals.
22	$\overline{\text{WE}}$	O	This is connected to the RAM WE terminal. When a "L level" signal is registered, the RAM will be set to the WRITE mode.
23	$\overline{\text{OE}}$	O	This is connected to the RAM OE terminal. When a "L level" signal is registered, the RAM will be set to the READ mode.
25 26 27 28 29 30 31 32	D8 D7 D6 D5 D4 D3 D2 D1	I/O I/O I/O I/O I/O I/O I/O I/O	These are connected to the RAM data terminals. The output mode is set when the cycle at the data input terminal is WE = "L", and the input mode is set when the cycle is WE = "H".
33	DEP	O	This is the output terminal for the audio frequency characteristics switching signals of the audio filter. The emphasis will be required when "H" is registered.

Terminal number	Terminal code	I/O	Outline of functions
34	$\overline{Q1}$	0	Connected to the DAC input, the parallel signals are output by way of the internal digital filter from these terminals. The output is in alternation from the left and right channels. The output rate for each channel is 88.2kHz. Connect either Q16 or ($\overline{Q16}$), according to the DAC to be used.
35	$\overline{Q2}$	0	
36	$\overline{Q3}$	0	
37	$\overline{Q4}$	0	
38	$\overline{Q5}$	0	
39	$\overline{Q6}$	0	
40	$\overline{Q7}$	0	
41	$\overline{Q8}$	0	
42	$\overline{Q9}$	0	
43	$\overline{Q10}$	0	
44	$\overline{Q11}$	0	
45	$\overline{Q12}$	0	
46	$\overline{Q13}$	0	
47	$\overline{Q14}$	0	
48	$\overline{Q15}$	0	
49	Q16	0	
50	Q16	0	
51	$\phi 2$	0	This is the crystal clock (2.1609MHz) output.
52	SDO	I/O	This is the serial signal output for the DAC. Using a $\phi 2$ clock beat rate, the signals are output from LSB in the order of L channel 24 bit – R channel 25 bit.
53	SDSY	0	This is the synchronization signal output for the above serial signals. The level is "H" for L channel and "L" for R channel.
56	TEST	I+	This test terminal contains pull-up resistors, and is normally disconnected. Using an "L" signal, it is also possible to input serial signals with the same format as the above serial signals from the SDO terminal into the digital filter.
54	C1F1	0	This monitor output terminal depicts the C1 and C2 error correction operation mode.
55	C1F2	0	
57	C2F1	0	
58	C2F2	0	
59	R/L	0	This is the output terminal for the channel allocation signal of the DAC analog output. "H" is for the R channel, and "L" is for the L channel.
60	SWR	0	This is the deglitch signal for the respective channels of the DAC analog output.
61	SWL	0	
62	VDD	I	This is the +5V power supply terminal.
63	XIN	I	A crystal oscillator is connected between these terminals, which are used for the crystal clock (8.6436MHz) oscillation.
64	XOUT	0	

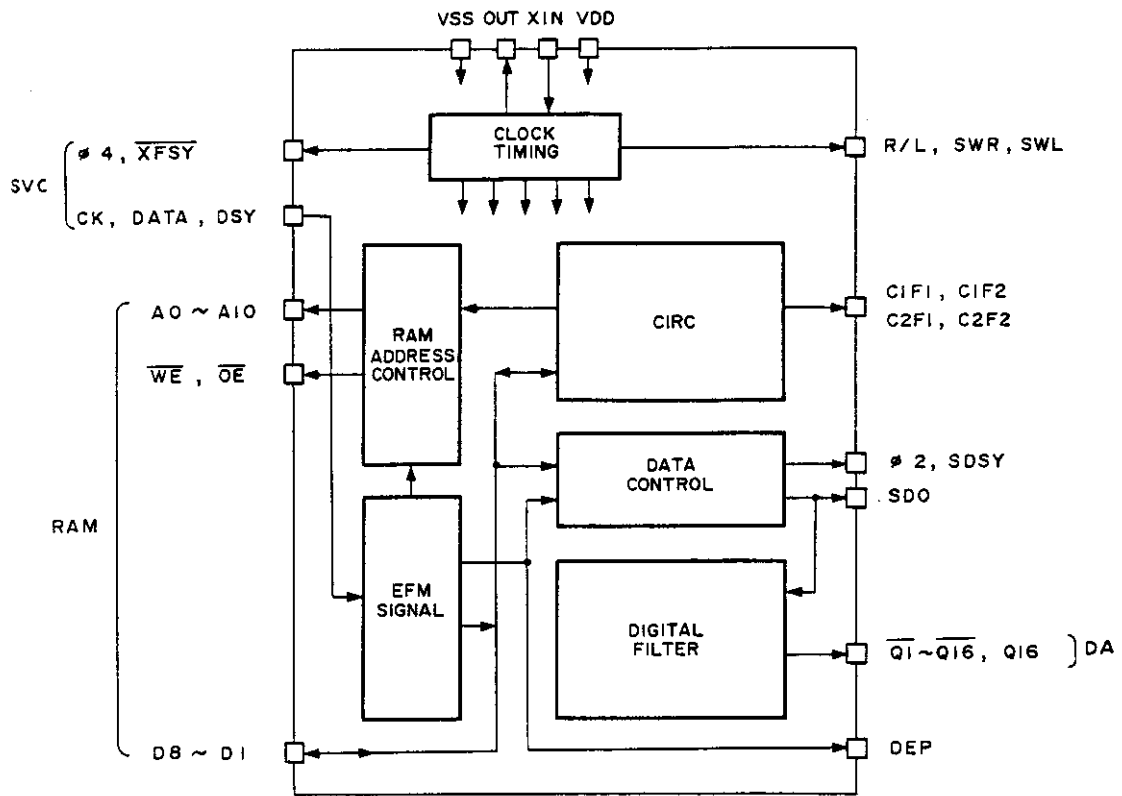

IC MOS YM-2601F

IC401 IC μ PD7516HCW-256

PIN	Port Name	Cord	Function	I/O	Active Level	RESET
1	P20	ADD8	External RAM address	O	H	L
2	P21	WE	External RAM line signal	O	L	H
3	P22	R/W	3531 R/W	O	H	L
4	P23	D-OSG	Tray opening driving	O	H	L
5	RESET					
6	PPO	Non used				
7	NC					
8	P00	WQ	3531 read request	I	H	*
9	SCK	SCK	3531 serial clock	O	L	H
10	SO	DIN	3531 Data in	O	H	L
11	SI	D OUT	3531 Data out	I	H	*
12	P60	KI 4	Key input port	I	H	*
13	P61	IR	Remote control data	I	H	*
14	P62	LA-ON	Laser ON	O	H	L
15	P63	DISC	Disc detection	I	H	*
16	P50	DATA 0	External RAM address remote control data input	I/O	H	*
17	P51	DATA 1	External RAM address remote control data input	I/O	H	*
18	P52	DATA 2	External RAM address remote control data input	I/O	H	*
19	P53	DATA 3	External RAM address remote control data input	I/O	H	*
20	P10	KI 0	Key input port	I	H	*
21	P11	KI 1	Key input port	I	H	*
22	P12	KI 2	Key input port	I	H	*
23	P13	KI 3	Key input port	I	H	*
24	NC					
25	P40	ADD 0	External RAM address remote control data input	I/O	H	*
26	P41	ADD 1	External RAM address remote control data input	I/O	H	*
27	P42	ADD 2	External RAM address remote control data input	I/O	H	*
28	P43	ADD 3	External RAM address remote control data input	I/O	H	*
29	EVENT	Non used				
30	X2					
31	X1					
32	V _{ss}					

Pin	Port Name	Code	Function	I/O	Active Level	RESET
33	S7	Ph	Segment h	O	H	L
34	S6	Pg	Segment g	O	H	L
35	S5	Pf	Segment f	O	H	L
36	S4	Pe	Segment e	O	H	L
37	S3	Pd	Segment d	O	H	L
38	S2	Pc	Segment c	O	H	L
39	S1	Pb	Segment b	O	H	L
40	S0	Pa	Segment a	O	H	L
41	T15/S15	PAUSE LED	Pause LED static	O	H	L
42	T14/S14	PLAY LED	Play LED static	O	H	L
43	T13/S13	DISC LED	Disc LED static	O	H	L
44	T12/S12	STANDBY LED	Standby LED static	O	H	L
45	T11/S11	D-CSG	Tray closing driving	O	H	L
46	T10/S10	RECEIVE LED	Remote control code reception	O	H	L
47	T9/S9	T9	Index display 10	O	H	L
48	T8/S8	T8	Index display 1	O	H	L
49	T7	T7	Track display 10	O	H	L
50	T6	T6	Track display 1	O	H	L
51	T5	T5	Mode display A	O	H	L
52	T4	T4	Mode display A	O	H	L
53	T3	T3	Time display minute 10	O	H	L
54	T2	T2	Time display minute 1	O	H	L
55	T1	T1	Time display seconds 10	O	H	L
56	T0	T0	Time display seconds 1	O	H	L
57	V LOAD					
58	V PRE					
59	P30	ADD 4	External RAM address	O	H	*
60	P31	ADD 5	External RAM address	O	H	*
61	P32	ADD 6	External RAM address	O	H	*
62	P33	ADD 7	External RAM address	O	H	*
63	INT 1	OPEN/CLOSE	OPEN/CLOSE key	I		*
64	VDD					

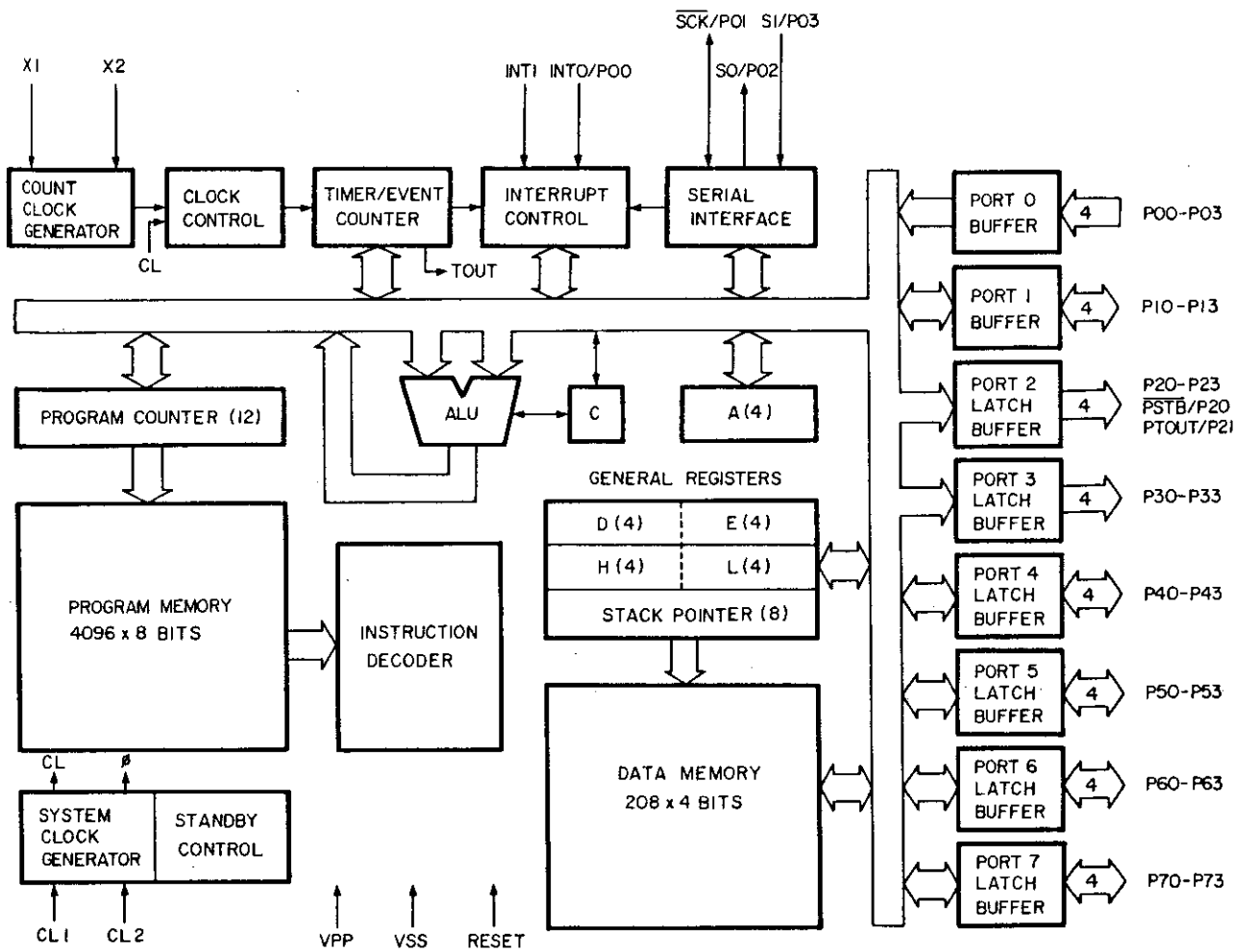

Micro-processor UPD7516CW-256

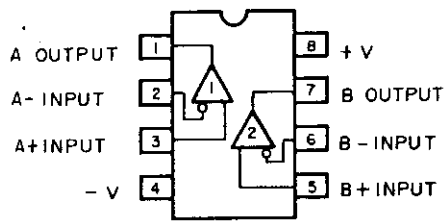

Operational Amp.
 IC M5220L, NJM4560D,
 BA4558
 M5218L

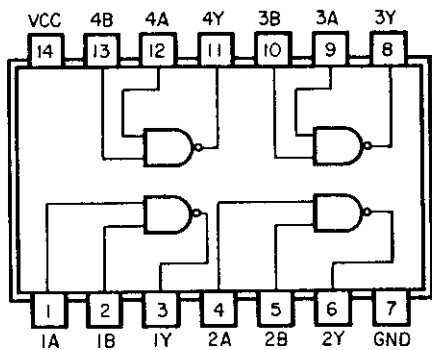

NAND GATE MOS IC SN74HC00N

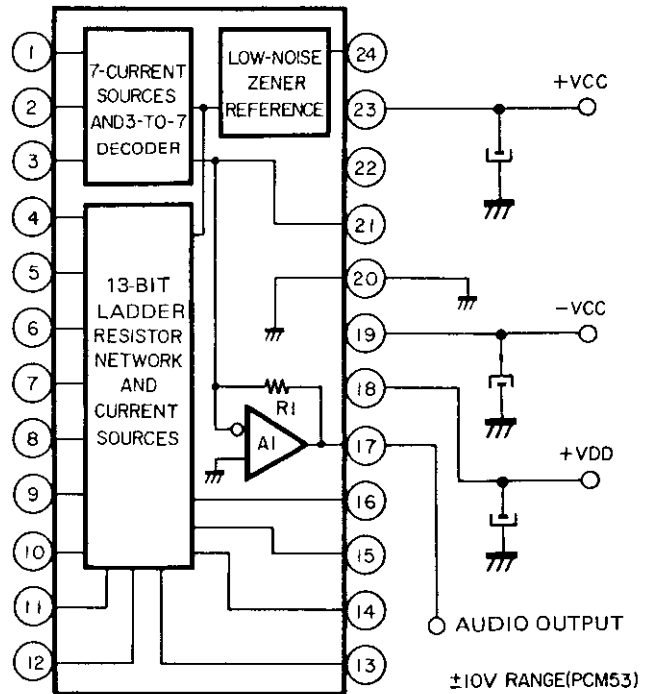

IC PCM54JP

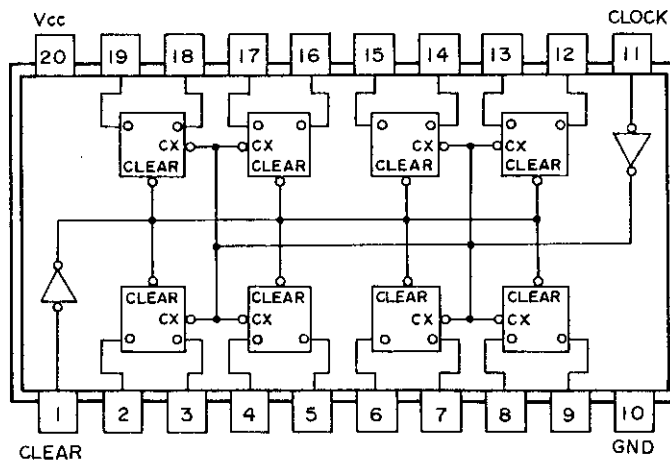

74HC273

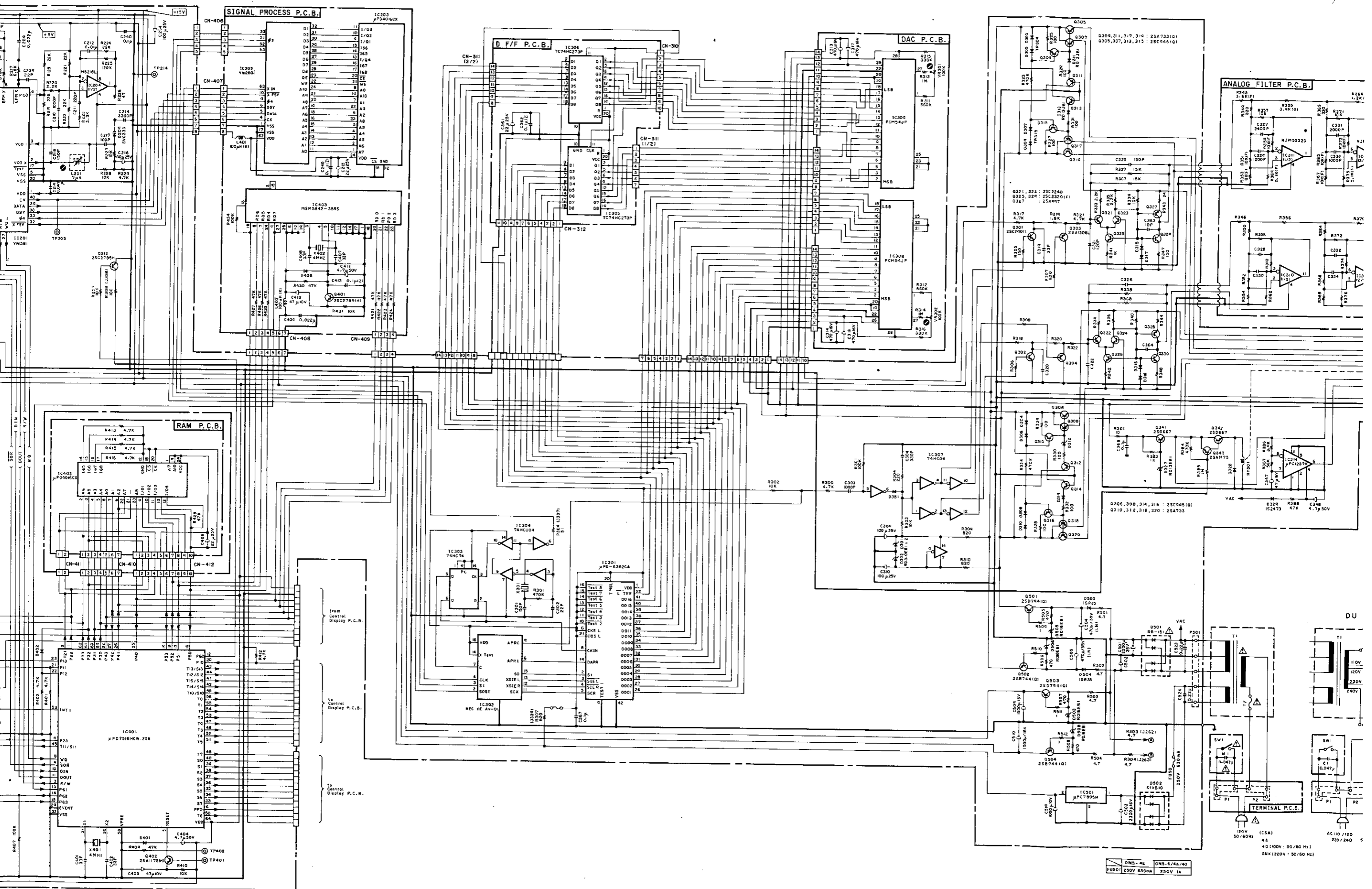

DMS - #E 0N3-4/4A/40
 FUS01 250V 630mA 250V 1A
 40 (100V: 50/60 Hz)
 5M (220V: 50/60 Hz)

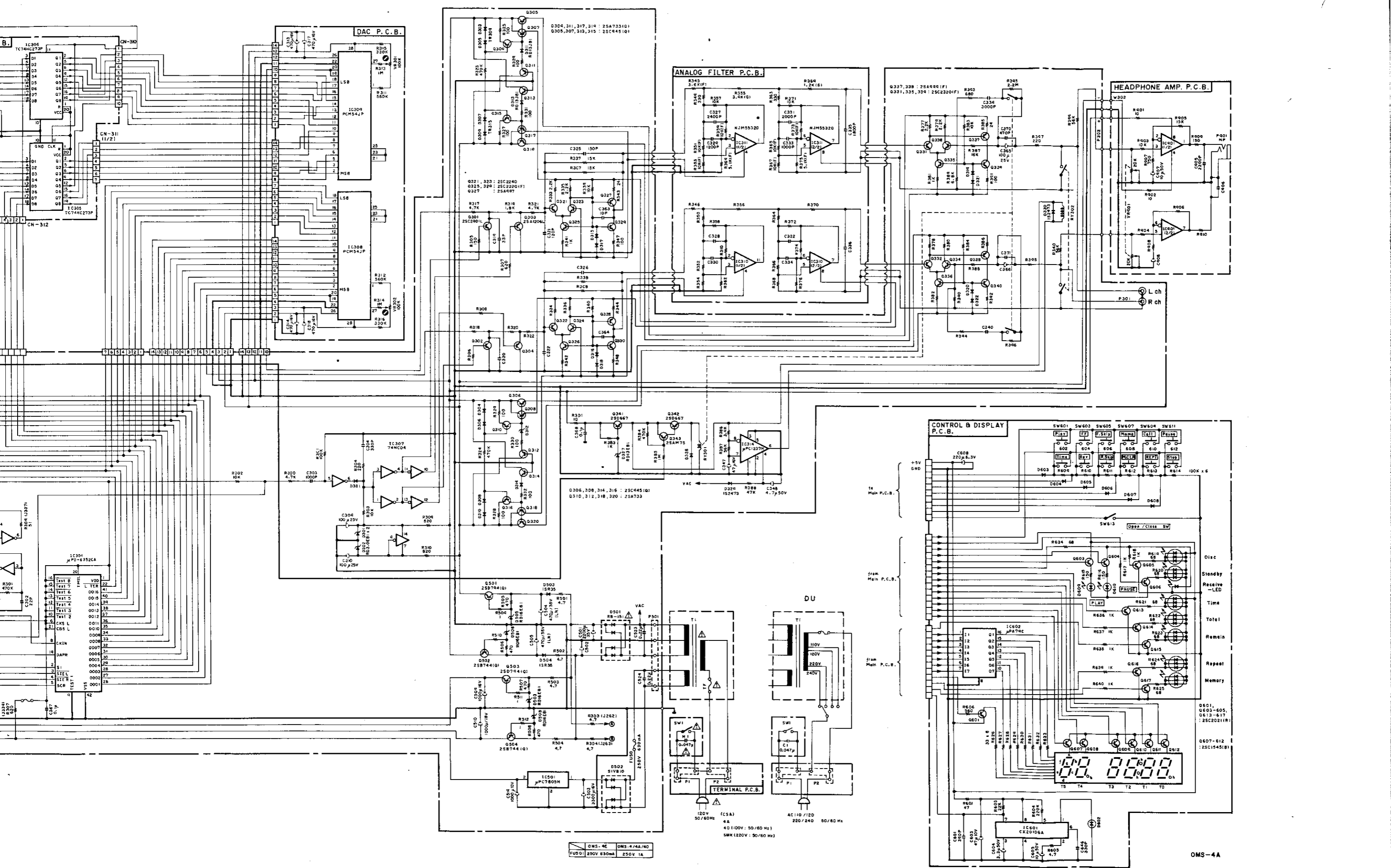

8. WIRING DIAGRAM

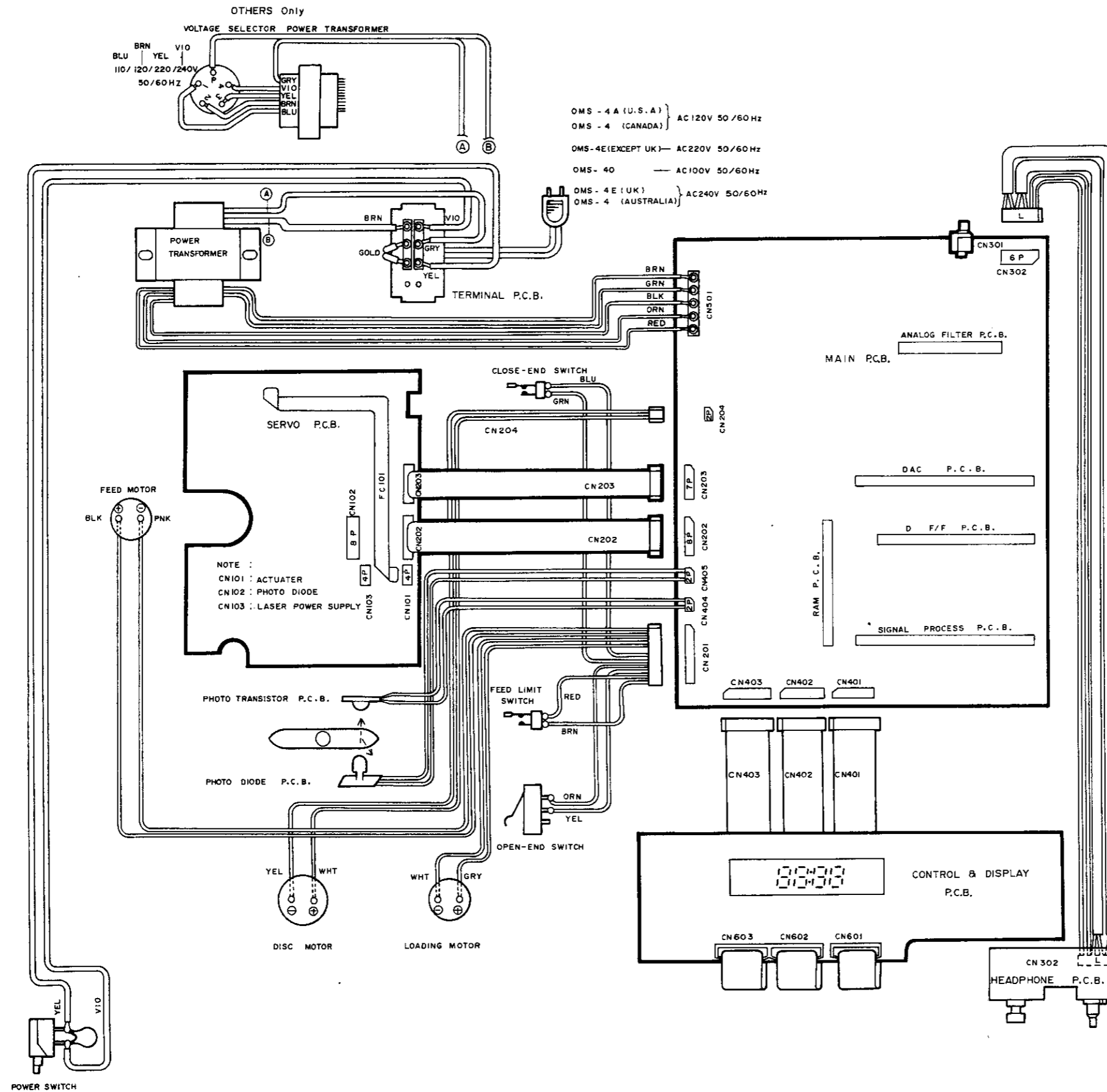

- Notes:
1. Table of wire colors

BRN - Brown	BLU - Blue
RED - Red	VIO - Violet
ORN - Orange	GRY - Gray
YEL - Yellow	WHT - White
GRN - Green	BLK - Black
 2. Component side view of the P.C.B. is illustrated unless otherwise specified.
 3. Wire tube color is shown in ().

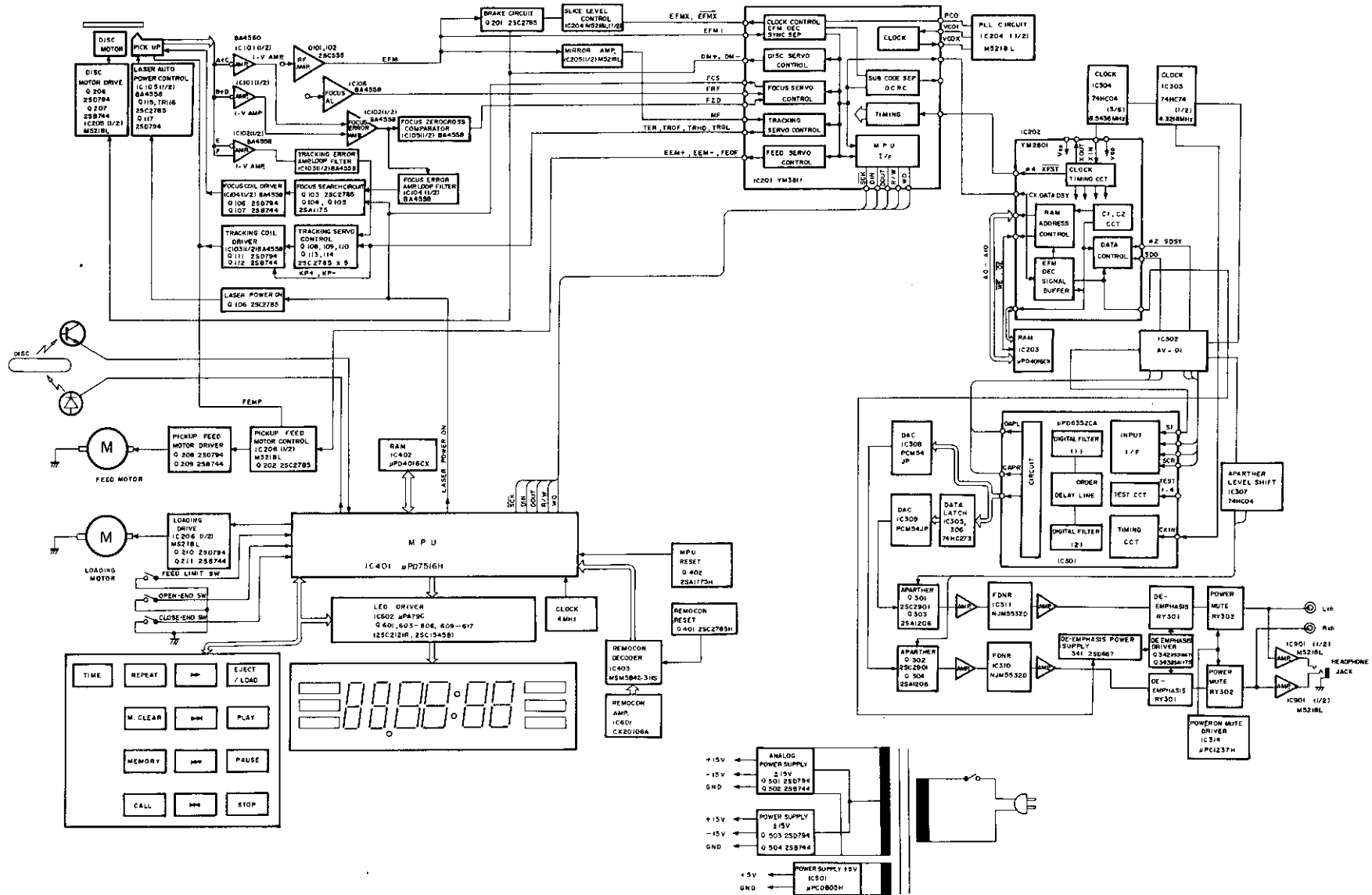

10. SPECIFICATIONS

■ Main Unit

System	Compact Disc digital audio
Signal Readout	Optical (semiconductor laser)
Error Correction	CIRC principle
Number of Channels	2 channels, stereo
Sampling Frequency	44.1 kHz
Quantization	16 bit linear
Disc Rotational Velocity	Approx 200 to 500 rpm (constant linear velocity)
Wow-and-Flutter	Below measurement limit
Frequency Response	5 – 20,000 Hz \pm 0.5 dB
Signal-to-Noise Ratio (IHF A-WTD)	Better than 100dB
Dynamic Range	Better than 93 dB
Total Harmonic Distortion (1kHz)	0.004%
Total Harmonic Distortion + Noise (1 kHz)	0.0055%
Channel Separation	Better than 94 dB
Output (Line 1kHz 0dB)	2.5V/220 Ω
(Headphone 1kHz, 0dB)	Approx. 35mW into 40 Ω
Power Requirements	120, 220, 240 or 110-120/220 – 240V AC, 50/60 Hz (According to country of sale)
Power Consumption	40 W max.
Dimensions	430 (W) x 100 (H) x 322 (D) mm 16-15/16 (W) x 3-15/16 (H) x 12-11/16 (D) inches
Approximate Weight	7.1 kg, 15 lbs., 10 oz.

■ Remote Control Unit (RM-4CD)

Principle	Infrared Pulse system
Power Supply	3V DC (1.5 V x 2)
Dimensions	50 (W) x 19 (H) x 162 (D) mm 2 (W) x 3/4 (H) x 6-3/8 (D) inches
Approximate Weight	100 g, 3-1/2 oz (including batteries)

- Specifications and design are subject to change for further improvement without notice.