



Service Manual

Nakamichi

CA-5

CA-5E

Control Amplifier



CONTENTS

1. General	1
2. Parts Location for Electrical Adjustment	1
3. Electrical Adjustment	2
3. 1. DC Balance Adjustment for MC Amp.	2
4. Mechanism Ass'y and Parts List	2
4. 1. Synthesis	2
4. 2. Front Panel Ass'y (A01)	3
4. 3. Chassis Ass'y (A02)	3
4. 4. Rear Panel Ass'y (B01)	4
5. Mounting Diagrams and Parts List	5
5. 1. Pin Jack A P.C.B. Ass'y	5
5. 2. Pin Jack B P.C.B. Ass'y	5
5. 3. Pin Jack C P.C.B. Ass'y	5
5. 4. Power LED P.C.B. Ass'y	5
5. 5. Power Switch P.C.B. Ass'y	6
5. 6. Load Switch P.C.B. Ass'y	6
5. 7. Switch Volume P.C.B. Ass'y	6
5. 8. Main P.C.B. Ass'y	8
6. Schematic Diagram	9
7. Wiring Diagram	11
8. Block Diagram	13
9. Specifications	14

1. GENERAL

1.1. Voltage Selector

Voltage selector is installed on the rear panel for Other version of the Nakamichi CA-5. This voltage selector can select either 120 V or 220 — 240 V at customer's disposal.

1.2. Packing Materials, Owner's Manual and Power Cord

<u>Part No.</u>	<u>Description</u>	<u>Q'ty</u>
0F03867A	Carton CA-5	1
0F03868B	Carton CA-5E	1
0F03863A	Packing L	1
0F03864A	Packing R	1
0F03684A	Polyethylene Sheet	1
0D04534A	Owner's Manual English	1
0D04533A	Owner's Manual English/German/French	1
0B90136A	Power Cord CA-5 (U.S.A., Canada & Others)	1
0B90139A	Power Cord CA-5 (Australia)	1
0B90138A	Power Cord CA-5E (220V Class 2)	1
0B90140A	Power Cord CA-5E (UK)	1
0F03887A	Power Cord Band	1

2. PARTS LOCATION FOR ELECTRICAL ADJUSTMENT

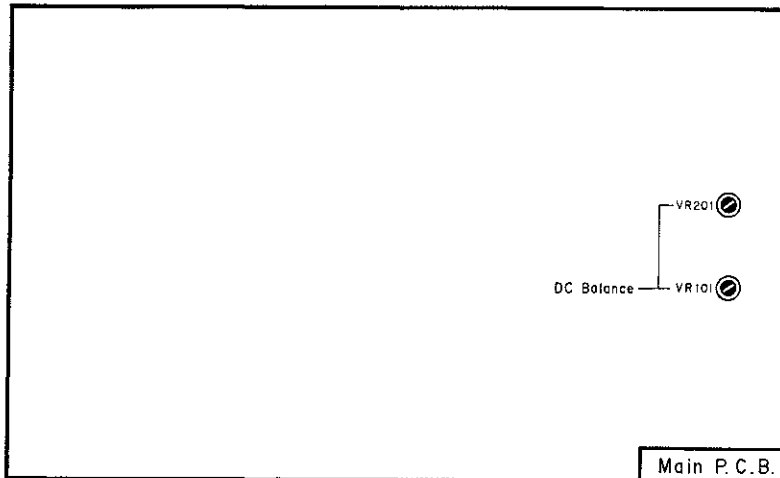

Fig. 2

3. ELECTRICAL ADJUSTMENT

3.1. DC Balance Adjustment for MC Amp.

- (1) Before starting adjustment, allow two or three minutes after the power is turned ON.
- (2) Connect a DC voltmeter to the Phono Input Jack L (R).
- (3) Set the Cartridge Selector to "Moving Coil".
- (4) Adjust VR101 (VR201) to obtain 0 ± 10 mV on the DC voltmeter.

4. MECHANISM ASS'Y AND PARTS LIST

4.1. Synthesis

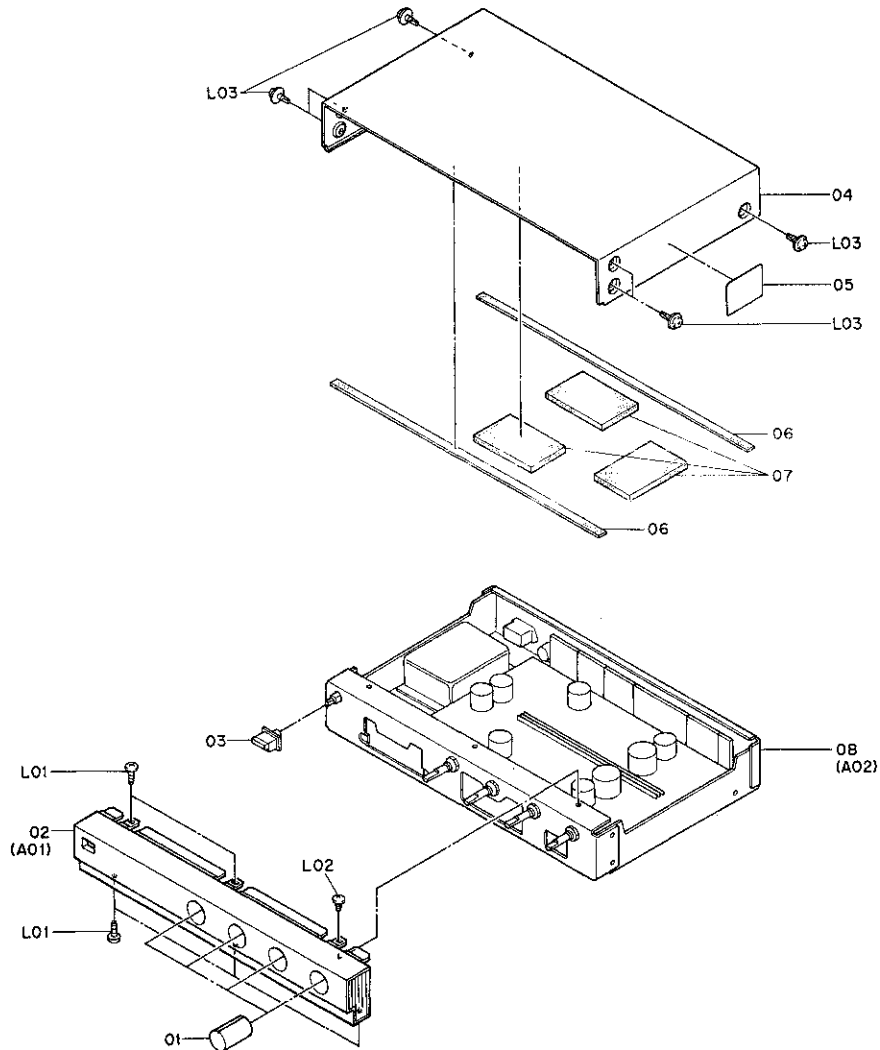

Fig. 4.1

Schematic Ref. No.	Part No.	Description	Qty	Schematic Ref. No.	Part No.	Description	Qty
		Synthesis Serial No.: B10601001 —		L01	0E00921A	BT 3x8 @ Binding (Black Chromate)	5
01	HA04798A	Volume Knob Ass'y	1	L02	0E03013A	BT 3x5 @ Binding	1
02	HA04826A	Front Panel Ass'y CA-5	1	L03	0E03278A	BT 3x8 @ Pan Washer-faced (Black Chromate)	6
	HA04827A	Front Panel Ass'y CA-5E					
03	HA04799B	Power Button Ass'y	1				
04	0H04628A	Top Cover	1				
05	0M04377B	Caution Label	1				
06	0J05002C	Top Cover Himelon	2				
07	0J05021A	Cushion	3				
08	—	Chassis Ass'y	1				

4.2. Front Panel Ass'y (A01)

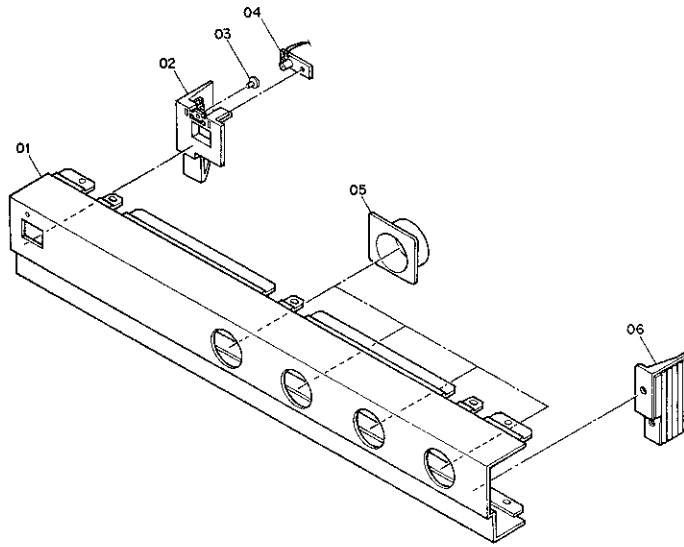

Fig. 4.2

4.3. Chassis Ass'y (A02)

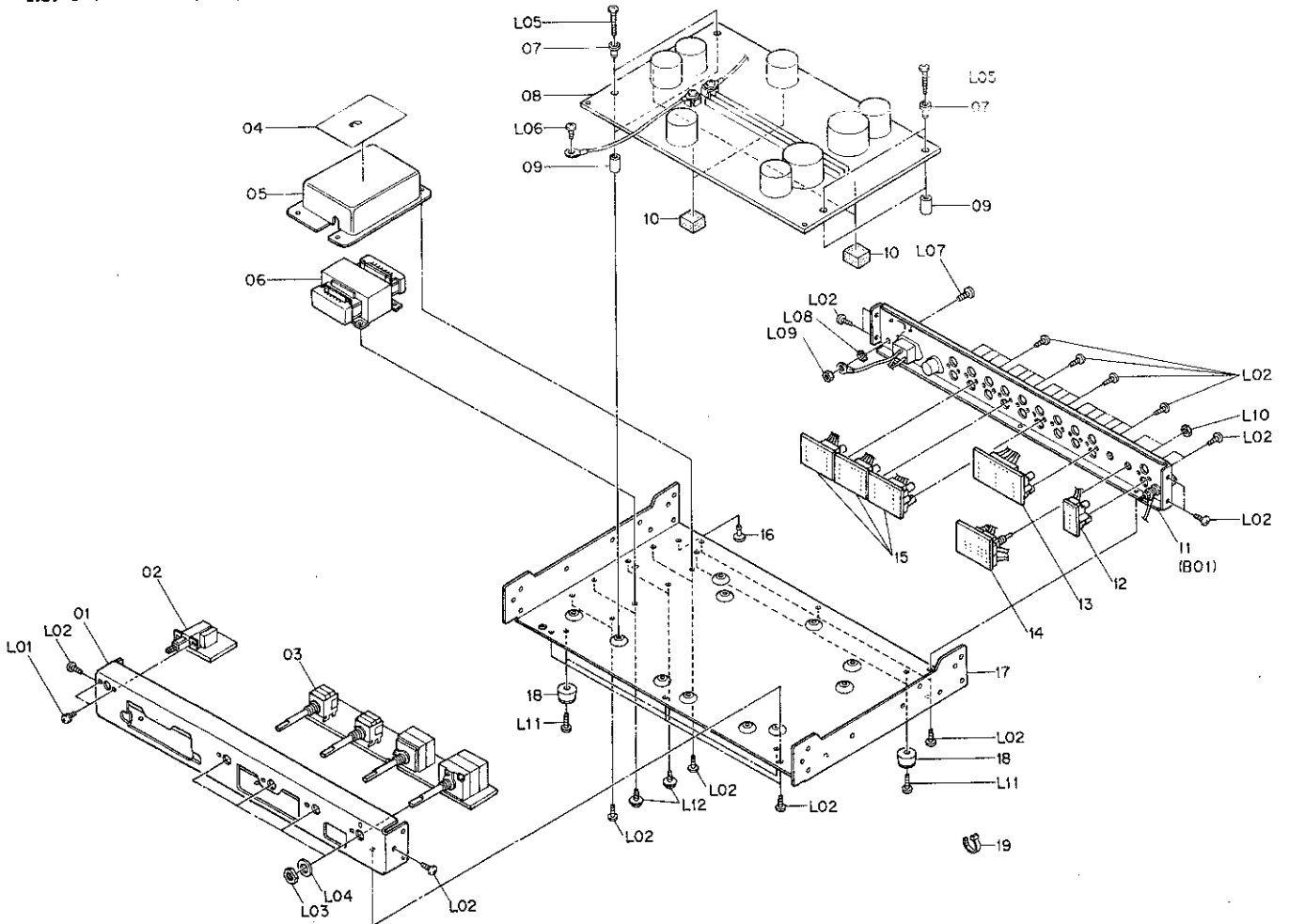

Fig. 4.3

4.4. Rear Panel Ass'y (B01)

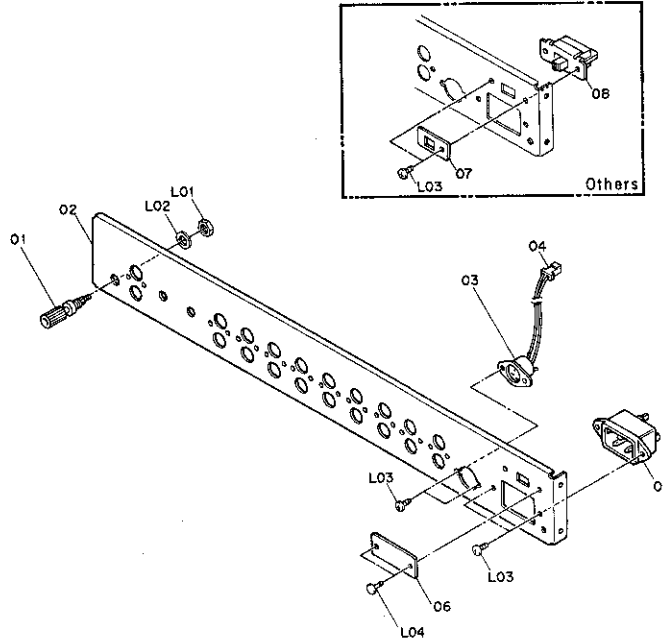

Fig. 4.4

Schematic Ref. No.	Part No.	Description	Qty	Schematic Ref. No.	Part No.	Description	Qty
A01	HA04826A	Front Panel Ass'y CA-5	1	—	OB90121A	Fuse 500mA CA-5 (U.S.A., Canada & Others)	2
	HA04827A	Front Panel Ass'y CA-5E Serial No.: B10601001 —	1	—	OB90159A	Fuse T250mA CA-5 (Australia) & CA-5E	2
01	OH04616B	Front Panel CA-5	1	—	OB90089A	Fuse Holder CA-5 (U.S.A., Canada & Others)	2
02	OH04617B	Front Panel CA-5E	1	—	OB90090A	Fuse Holder CA-5 (Australia) & CA-5E	2
03	OH04640B	Side Panel L	1				
04	OH04639B	Lens	1	L01	OE00612A	M3x6 ⊕ Pan (2A)	2
05	BA05723A	Power LED P.C.B. Ass'y	1	L02	OE00921A	BT 3x8 ⊕ Binding (Black Chromate)	36
06	OH04648B	Volume Knob Holder	4	L03	—	Nut	4
06	OH04641A	Side Panel R	1	L04	—	Washer	4
A02	—	Chassis Ass'y Serial No.: B10601001 —	1	L05	OE03294A	BT 3x18 ⊕ Binding (Black Chromate)	4
01	OJ04988A	Front Chassis	1	L06	OE03030A	M3x6 ⊕ Binding (Nickel)	1
02	BA05855A	Power Switch P.C.B. Ass'y CA-5 (U.S.A. & Canada)	1	L07	OE03058A	M4x8 ⊕ Binding (Black Chromate)	1
	BA05856A	Power Switch P.C.B. Ass'y CA-5 (Australia) & CA-5E	1	L08	OE00078A	Washer 4mm Toothed Lock	1
	BA05857A	Power Switch P.C.B. Ass'y CA-5 (Others)	1	L09	OE00669A	Nut Hex. M4	1
03	BA05724A	Switch Volume P.C.B. Ass'y	1	L10	—	Nut	2
04	OM04680B	Transformer Label	1	L11	OE00865A	BT 3x10 ⊕ Binding	4
05	OH04642A	Transformer Cover	1	L12	OE03278A	BT 3x8 ⊕ Pan Washer-faced (Black Chromate)	4
06	OB50050A	Power Transformer 120V CA-5 (U.S.A. & Canada)	1	B01	HA04831A	Rear Panel Ass'y CA-5 (U.S.A., Canada & Australia)	1
	OB50052A	Power Transformer 220/240V CA-5 (Australia) & CA-5E	1		HA04829A	Rear Panel Ass'y CA-5 (Others)	1
	OB50053A	Power Transformer 120/220-240V CA-5 (Others)	1		HA04830A	Rear Panel Ass'y CA-5E Serial No.: B10601001 —	1
07	OJ05020A	Collar Bushing A	4	01	OB81373A	Ground Terminal	1
08	BA05718A	Main P.C.B. Ass'y	1	02	OH04658D	Rear Panel CA-5	1
09	OJ05019A	Collar Bushing B	4	03	OH04659D	Rear Panel CA-5E	1
10	OJ05005A	Cushion	4	04	OB81372A	3P DIN Socket	1
11	HA04829A	Rear Panel Ass'y CA-5 (Others)	1	05	OB82436A	2P-H Connector	1
	HA04830A	Rear Panel Ass'y CA-5E	1	06	OB90087A	AC Inlet	1
	HA04831A	Rear Panel Ass'y CA-5 (U.S.A., Canada & Australia)	1	07	OJ04601B	Cover Plate (Except Others)	1
12	BA05718A	Pin Jack A P.C.B. Ass'y	1	08	OM03948A	Voltage Lock Plate CA-5 (Others)	1
13	BA05719A	Pin Jack B P.C.B. Ass'y	1	08	OB07092U	Voltage Selector CA-5 (Others)	1
14	BA05717A	Load Switch P.C.B. Ass'y	1	L01	—	Nut	1
15	BA05720A	Pin Jack C P.C.B. Ass'y	3	L02	—	Washer	1
16	OJ05028A	Plastic Plug	1	L03	OE00985A	M3x6 ⊕ Binding (Black Chromate) (Except Others)	4
17	OH04622B	Main Chassis	1		OE00985A	M3x6 ⊕ Binding (Black Chromate) CA-5 (Others)	6
18	OJ03564A	Leg	4	L04	OB08583A	Plastic Rivet (Except Others)	2
19	OB08515A	Insu-Lock	10				
—	OB82437B	Ground Wire A	1				
—	OB82439A	Ground Wire C	1				

5. MOUNTING DIAGRAMS AND PARTS LIST

- Notes: 1. Mounting diagram shows a dip side view of the printed circuit board.
 2. Diode is 1SS53, 1S1555, or 1SS176 unless otherwise specified.
 3. Abbreviation for part name:
 TR — Transistor, SiD — Silicon Diode, ZD — Zener Diode
 RK — Carbon Resistor, RM — Metal Film Resistor, RF — Fail Safe Type Resistor
 CE — Electrolytic Capacitor, CM — Mylar Capacitor, CC — Ceramic Capacitor, CP — PP Capacitor,
 CT — Tantalum Capacitor, CF — Film Capacitor, C — Mica Capacitor

5.1. Pin Jack A P.C.B. Ass'y

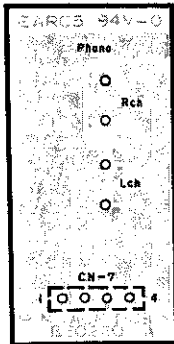

Fig. 5.1

5.2. Pin Jack B P.C.B. Ass'y

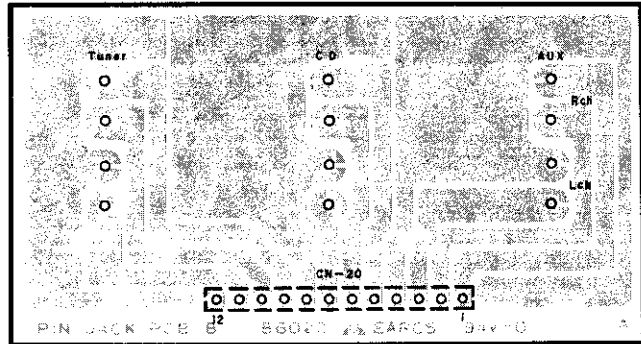

Fig. 5.2

5.3. Pin Jack C P.C.B. Ass'y

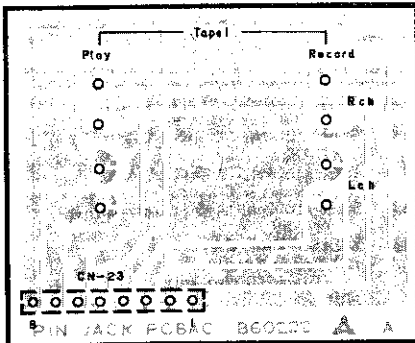

Fig. 5.3.1

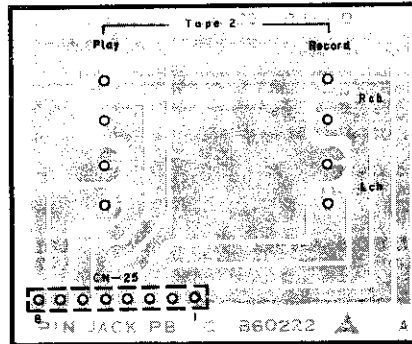

Fig. 5.3.2

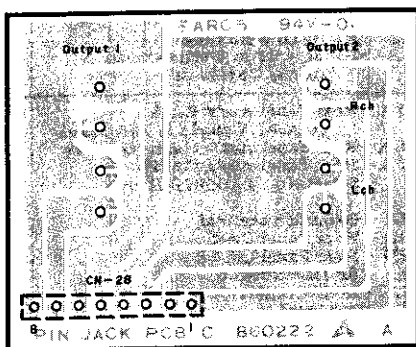

Fig. 5.3.3

5.4. Power LED P.C.B. Ass'y

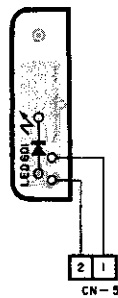

Fig. 5.4

Schematic Ref. No.	Part No.	Description
	BA05718A	Pin Jack A P.C.B. Ass'y
	OB60220A OB81374A	Pin Jack A P.C.B. 2P Pin Jack (1)
	BA05719A	Pin Jack B P.C.B. Ass'y
	OB60221A OB81374A	Pin Jack B P.C.B. 2P Pin Jack (3)
	BA05720A	Pin Jack C P.C.B. Ass'y
	OB60222A OB81374A	Pin Jack C P.C.B. 2P Pin Jack (2)
	BA05723A	Power LED P.C.B. Ass'y
LED601 CN5	OB60225A OB12215A OB82435A OJ04845A	Power LED P.C.B. LED Green 2P Connector Reflector (1)

5.5. Power Switch P.C.B. Ass'y

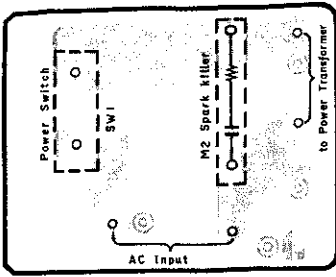

Fig. 5.5

5.6. Load Switch P.C.B. Ass'y

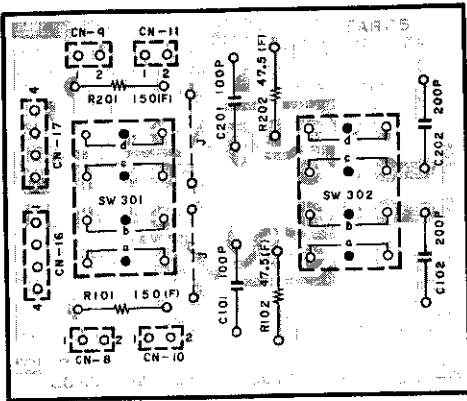

Fig. 5.6

5.7. Switch Volume P.C.B. Ass'y

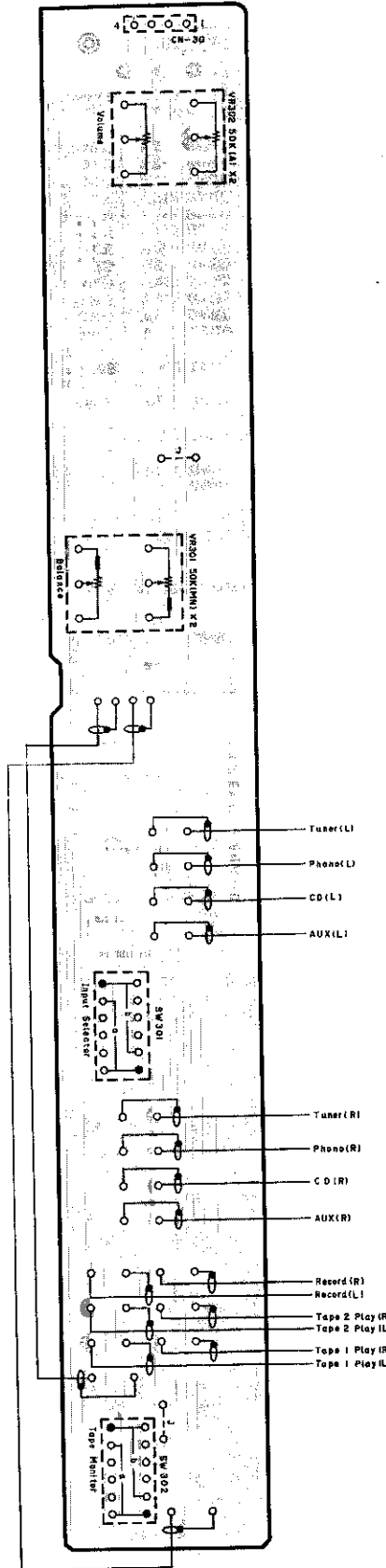

Fig. 5.7

Schematic Ref. No.	Part No.	Description
SW1 M2 M2 M2	BA05855A	Power Switch P.C.B. Ass'y CA-5 (U.S.A. & Canada)
	BA05856A	Power Switch P.C.B. Ass'y CA-5 (Australia) & CA-5E
	BA05857A	Power Switch P.C.B. Ass'y CA-5 (Others)
	OB60267A	Power Switch
	OB70002A	Spark Killer CA-5 (U.S.A. & Canada)
	OB08342A	Spark Killer CA-5 (Australia) & CA-5E
	OB08445A	Spark Killer CA-5 (Australia) & CA-5E
	OB08240A	Spark Killer CA-5 (Others)
	OB81409A	Switch GND CA-5 (U.S.A. & Canada)
	OB90019A	SK Binder (1)
OE00752A	Eyelet 2x3 (2)	
OB90059A	Spark Killer Cover CA-5 (Australia) & CA-5E (1)	
R101,201 R102,202 C101,201 C102,202	BA05717A	Load Switch P.C.B. Ass'y
	OB60219A	Load Switch P.C.B. RM 150 1/4W F
	OB22633A	RM 47.5 1/4W F
	OB22643A	C 100P 100V J
	OB41561A	C 200P 100V J
	OB41562A	Toggle Switch MTA604N (1)
OB70044A	Toggle Switch MTA604P (1)	
VR 301 VR 302 SW 301 SW 302	BA05724A	Switch Volume P.C.B. Ass'y
	OB60224A	Switch Volume P.C.B. Volume 50K(A) MN
	OB30037A	Volume 50K(A)x2
	OB30038A	Rotary Switch 4P
	OB70047A	Rotary Switch 3P
	OB70046A	8P Connector XH-CN (1)
	OB82433B	8P Connector XH-CN (1)
	OB82434B	4P Connector XH-CN (1)
OB82432B	4P Connector XH-CN (1)	
OB82445B	4P Connector SCN-CN (1)	

Schematic Ref. No.	Part No.	Description	Schematic Ref. No.	Part No.	Description
	BA05716A	Main P.C.B. Ass'y	ZD401	OB12197A	ZD 27V RD27JS-T1B1
	— MC Amp. —		ZD402	OB16191A	ZD 2.7V RD2.7E
Q101,201	OB06376A	FET 2SK170 (GR)	D401	OB06282A	Diode Bridge DBA10
VR101,201	OB32044A	Semi-fixed VR 5K	D402,403	OB12097A	SiD 1SS55
R103,203	OB09203A	RM 10K 1/4W F	R401	OB09305A	RM 100K 1/4W F
R104,204	OB09446A	RM 33.2K 1/4W F	R402,404	OB09203A	RM 10K 1/4W F
R105,205	OB09540A	RM 3.24K 1/4W F	R403	OB09491A	RM 1K 1/4W F
R106,206	OB09305A	RM 100K 1/4W F	R405	OB24066A	RF 3.3 1/2W J
R107,108	OB09547A	RM 2.21K 1/4W F	R406	OB22652A	RM 820 1/4W F
207,208			R407	OB09427A	RM 5.62K 1/4W F
R136,236	OB09491A	RM 1K 1/4W F	R408	OB09900A	RM 4.99K 1/4W F
C103,203	OB41547A	CP 3600P 100V F	C401,402	OB40332A	CE 1800µ 50V
C104,107	OB40333A	CE 470µ 25V	C404	OB40334A	CE 100µ 35V
108,204			C405	OB40335A	CE 470µ 50V
207,208			C406	OB40116A	CE 10µ 50V
C105,205	OB41545A	C 300P 100V J		OB81375A	Screw Terminal P-100 (2)
C106,206	OB41543A	CM 1µ 125V		OB81376A	Screw Terminal P-104 (2)
	— Eq. Amp. —			OB90077A	Bus Line Plate (3)
Q102,202	OB06365A	FET 2SK240 (GR)		— Miscellaneous —	
Q103,108	OB10102A	TR 2SA1320		OB60223A	Main P.C.B.
203,208				OB82424A	12P Connector SCN-CN 12P-12P (1)
Q104,106	OB10103A	TR 2SC3333		OB82425A	8P Connector SCN-CN 8P-8P (2)
107,204				OB82426A	8P Connector SCN-CN 8P-4Px2 (1)
206,207				OB82427A	4P Connector SCN-CN 4P-2Px2 (1)
Q105,205	OB10105A	FET 3N172		OB82428A	4P Connector SCN-CN 4P-2Px2 (1)
D101-104	OB06181A	SiD 1SS53 (8)		OB82429A	4P Connector SCN-CN 4P-2Px2 (1)
201-204				OB82430A	2P Connector SCN-CN 2P-2P (1)
R109,113	OB09491A	RM 1K 1/4W F		OB82431A	2P Connector SCN-CN 2P-2P (1)
125,209				OB82486A	4P Connector SCN-CN (1)
213,225					
R110,210	OB22638A	RM 47.5K 1/4W F			
R111,120	OB22639A	RM 681 1/4W F			
211,220					
R112,212	OB09760A	RM 332 1/4W F			
R114,115	OB09340A	RM 15K 1/4W F			
214,215					
R116,119	OB22576A	RM 475 1/4W F			
216,219					
R117,217	OB22641A	RM 887K 1/4W F			
R118,218	OB09562A	RM 75K 1/4W F			
R121,221	OB22642A	RM 221 1/4W F			
R122,123	OB09177A	RF 47 1/4W J			
222,223					
R124,224	OB09305A	RM 100K 1/4W F			
C109,209	OB41561A	C 100P 100V J			
C110,210	OB41546A	C 20µ 200V K			
C111,211	OB41547A	CP 3600P 100V F			
C112,212	OB41548A	CP 1000P 100V F			
C113,213	OB41542A	C 40P 100V J			
C114,214	OB41544A	C 200P 100V J			
C115,215	OB41536A	CM 10µ 200V K			
TF101,201	OB08715A	Thermal Fuse 129			
	— Line Amp. —				
Q109,209	OB06365A	FET 2SK240 (GR)			
Q110,112	OB10103A	TR 2SC3333			
210,212					
Q111,211	OB10102A	TR 2SA1320			
D105,106	OB06181A	SiD 1SS53			
205,206					
R126,135	OB09491A	RM 1K 1/4W F			
226,235					
R127,134	OB09305A	RM 100K 1/4W F			
227,234					
R128,228	OB22639A	RM 681 1/4W F			
R129,229	OB09760A	RM 332 1/4W F			
R130,230	OB09547A	RM 2.21K 1/4W F			
R131,231	OB22640A	RM 22.1K 1/4W F			
R132,232	OB09340A	RM 15K 1/4W F			
R133,233	OB22642A	RM 221 1/4W F			
C117,217	OB41561A	C 100P 100V J			
C118,218	OB41542A	C 40P 100V J			
C119,219	OB41536A	CM 10µ 200V K			
RL301	OB90086A	MR Relay			
	— DC Supply —				
IC401	OB11165A	IC NJM7824			
IC402	OB11166A	IC NJM7924			
Q401,402	OB10103A	TR 2SC3333			
406					
Q403,404	OB10102A	TR 2SA1320			
Q405	OB06255A	TR 2SD880			

5.8. Main P.C.B. Assy

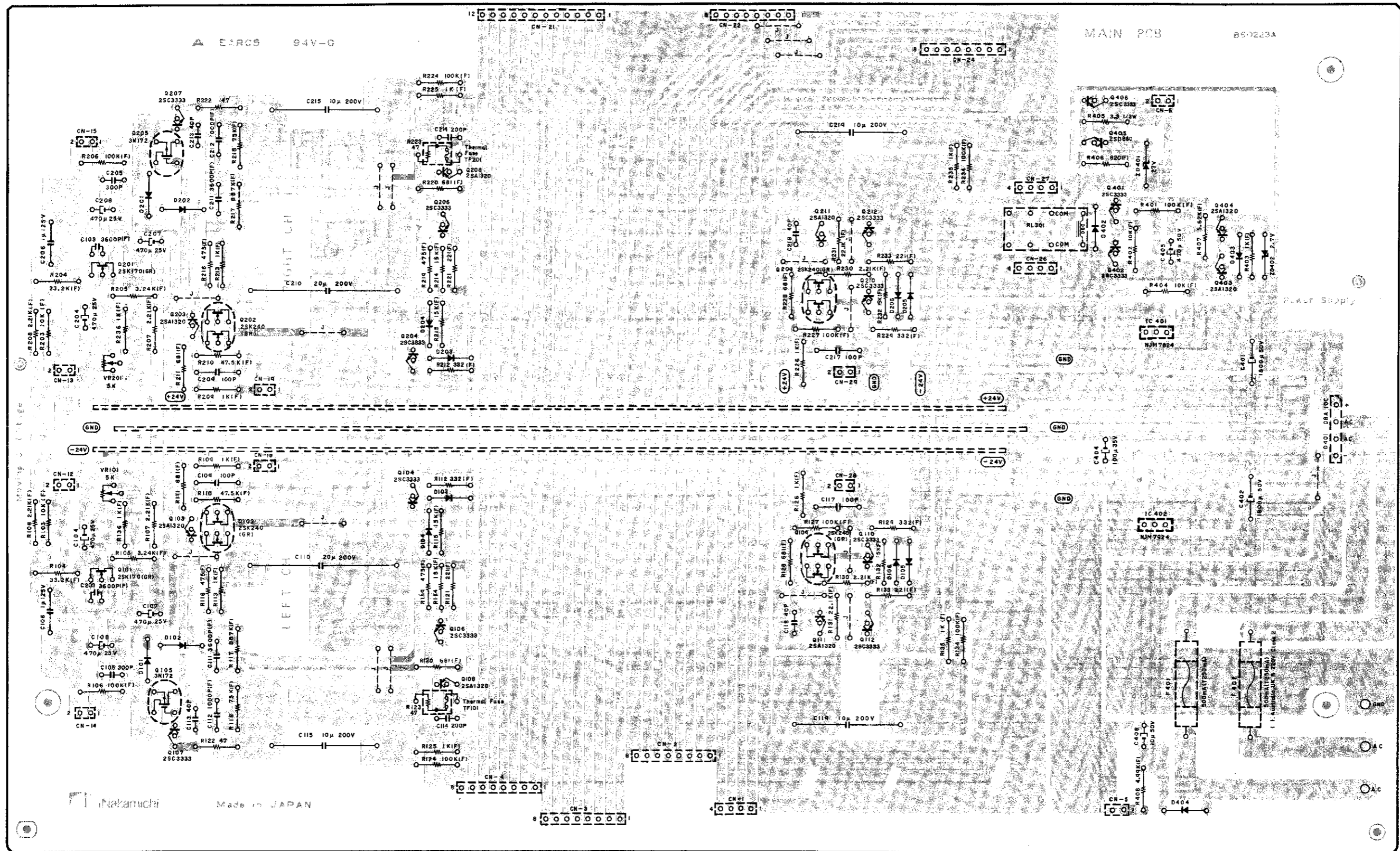

Fig. 5.8

6. SCHEMATIC DIAGRAM

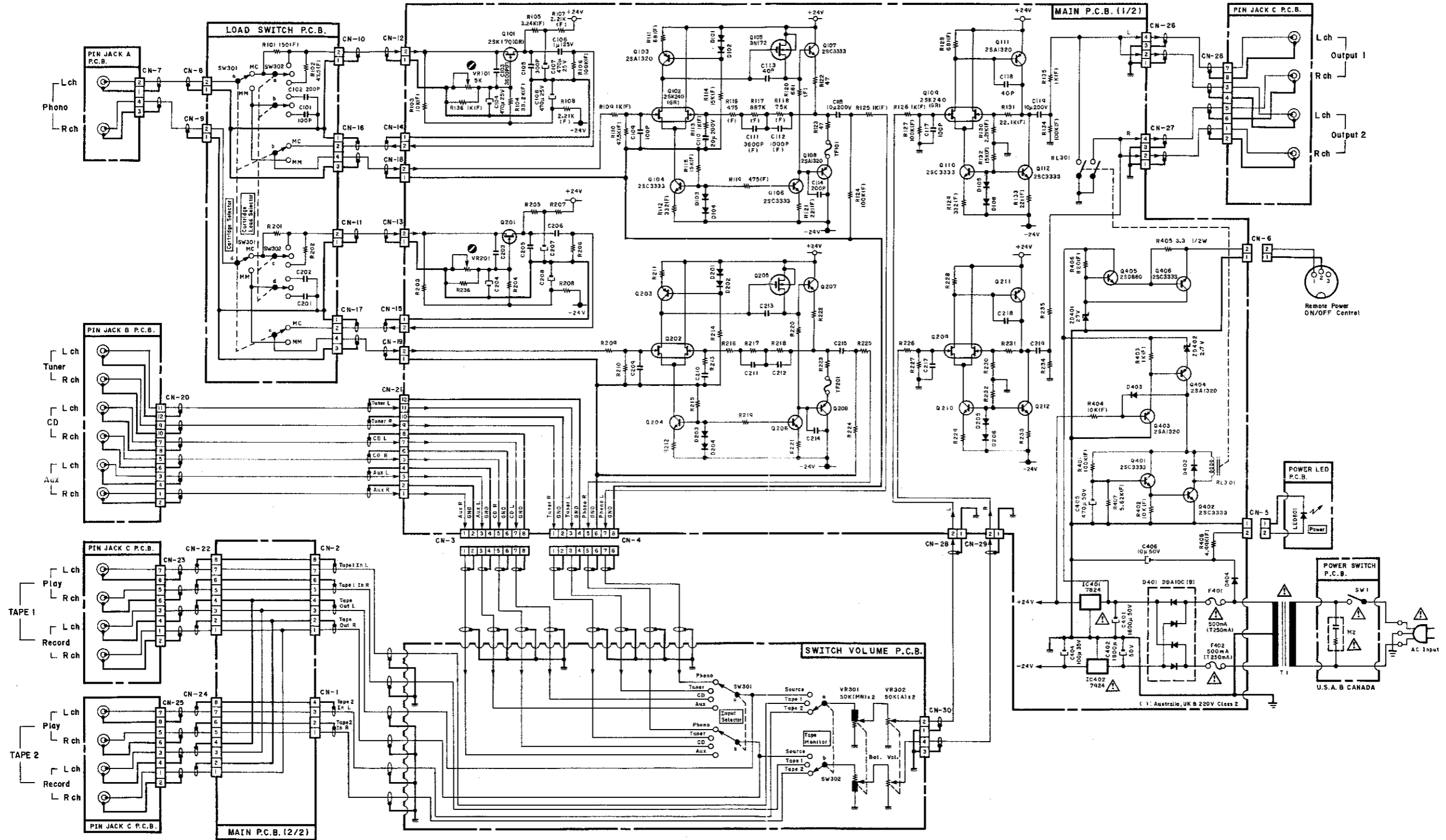

Fig. 6.1

Note: Diode is 1SS53, 1S1555, or 1SS176 unless otherwise specified.

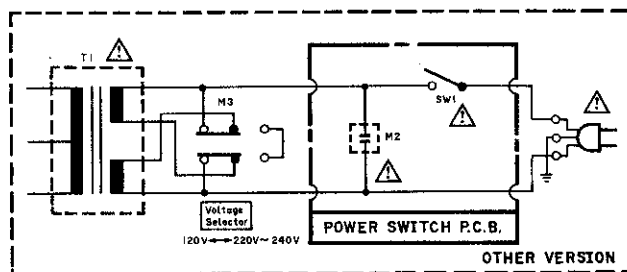
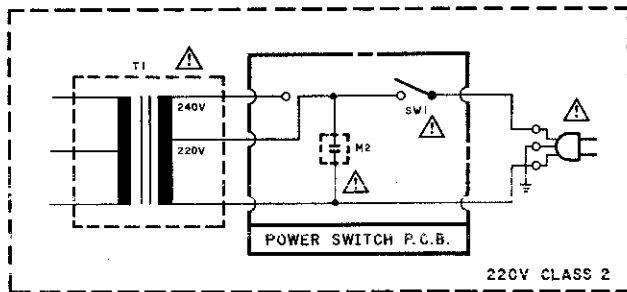
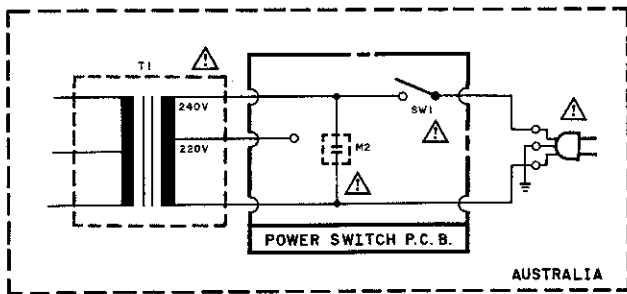
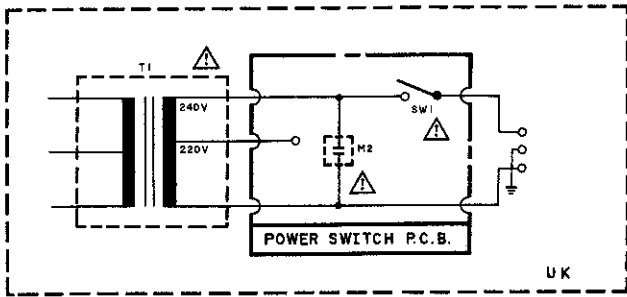



Fig. 6.2

WARNING:

Parts marked with the symbol  have critical characteristics.

Use **ONLY** replacement parts recommended by the manufacturer.

It is recommended that the unit be operated from a suitable DC supply or batteries during initial check-out procedures.

CAUTION:

Before returning the unit to the customer, make sure you make either (1) a leakage current check or (2) a line to chassis resistance check. If the leakage current exceeds 0.5 milliamp, or if the resistance from chassis to either side of the power cord is less than 240 k ohms, the unit is defective.

WARNING — DO NOT return the unit to the customer until the problem is located and corrected.

7. WIRING DIAGRAM

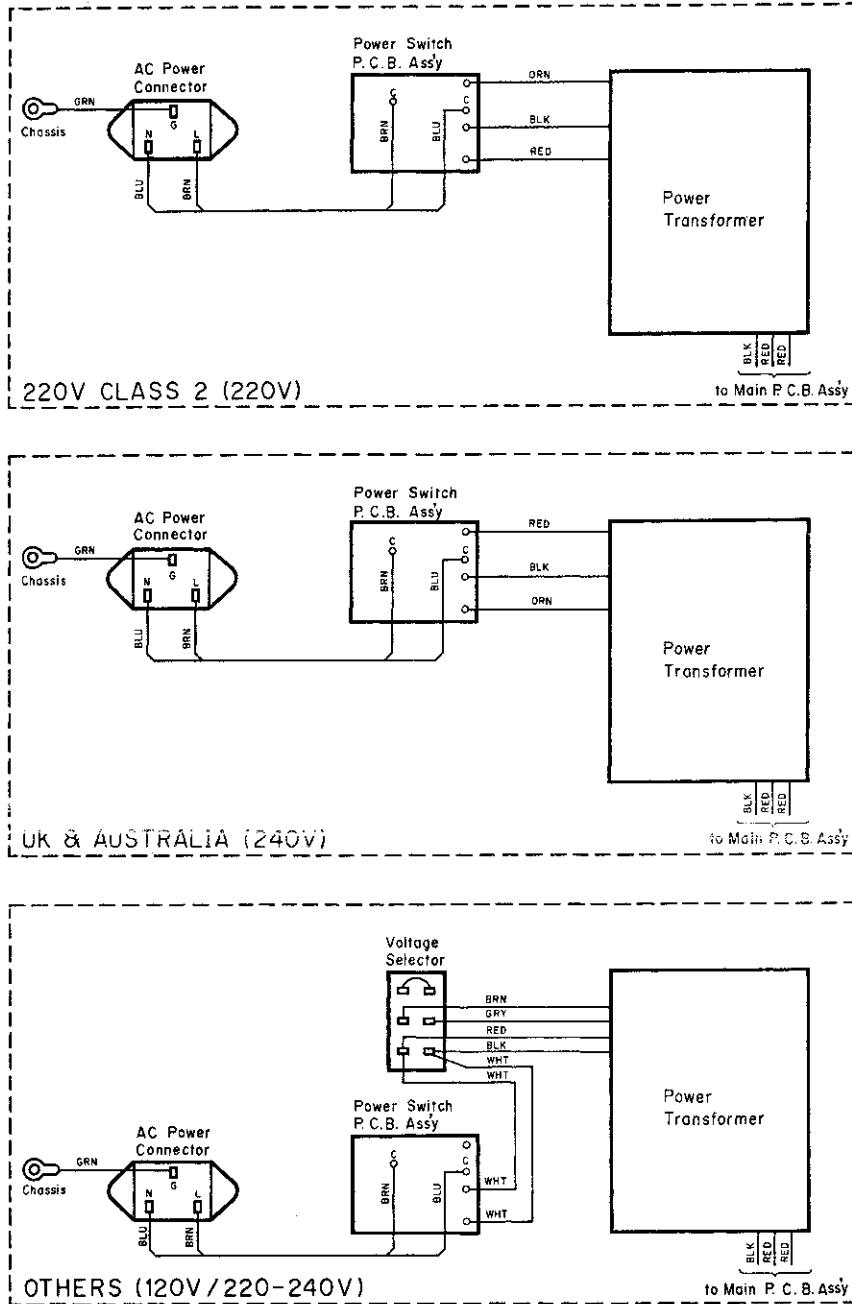

Fig. 7.1

Notes: 1 Table of wire colors

BRN — Brown	BLU — Blue
RED — Red	VIO — Violet
ORN — Orange	GRY — Gray
YEL — Yellow	WHT — White
GRN — Green	BLK — Black

2. Component side view of the P.C.B. is illustrated unless otherwise specified.
3. Wire tube color is shown in ().

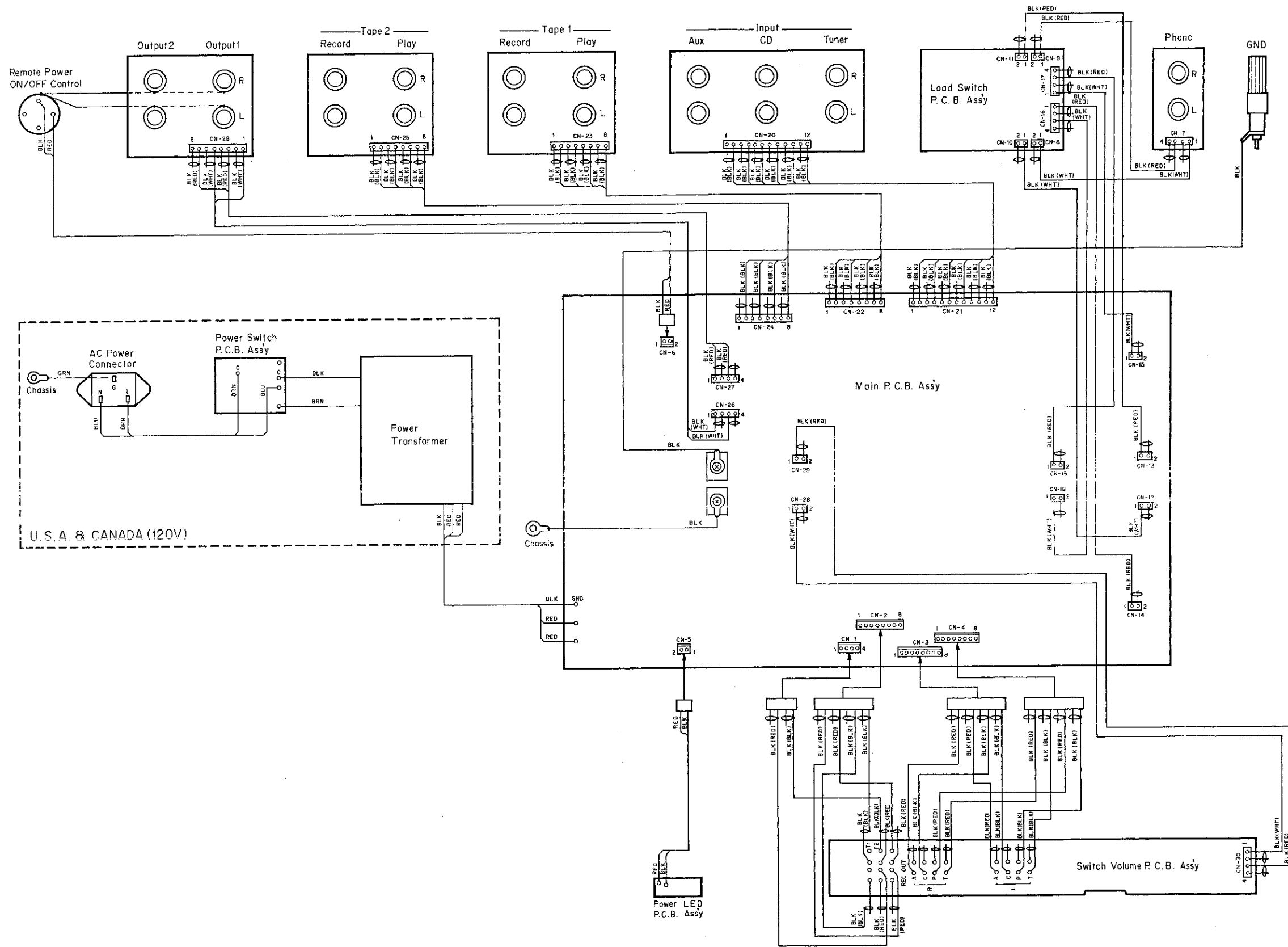

Fig. 7.2

8. BLOCK DIAGRAM

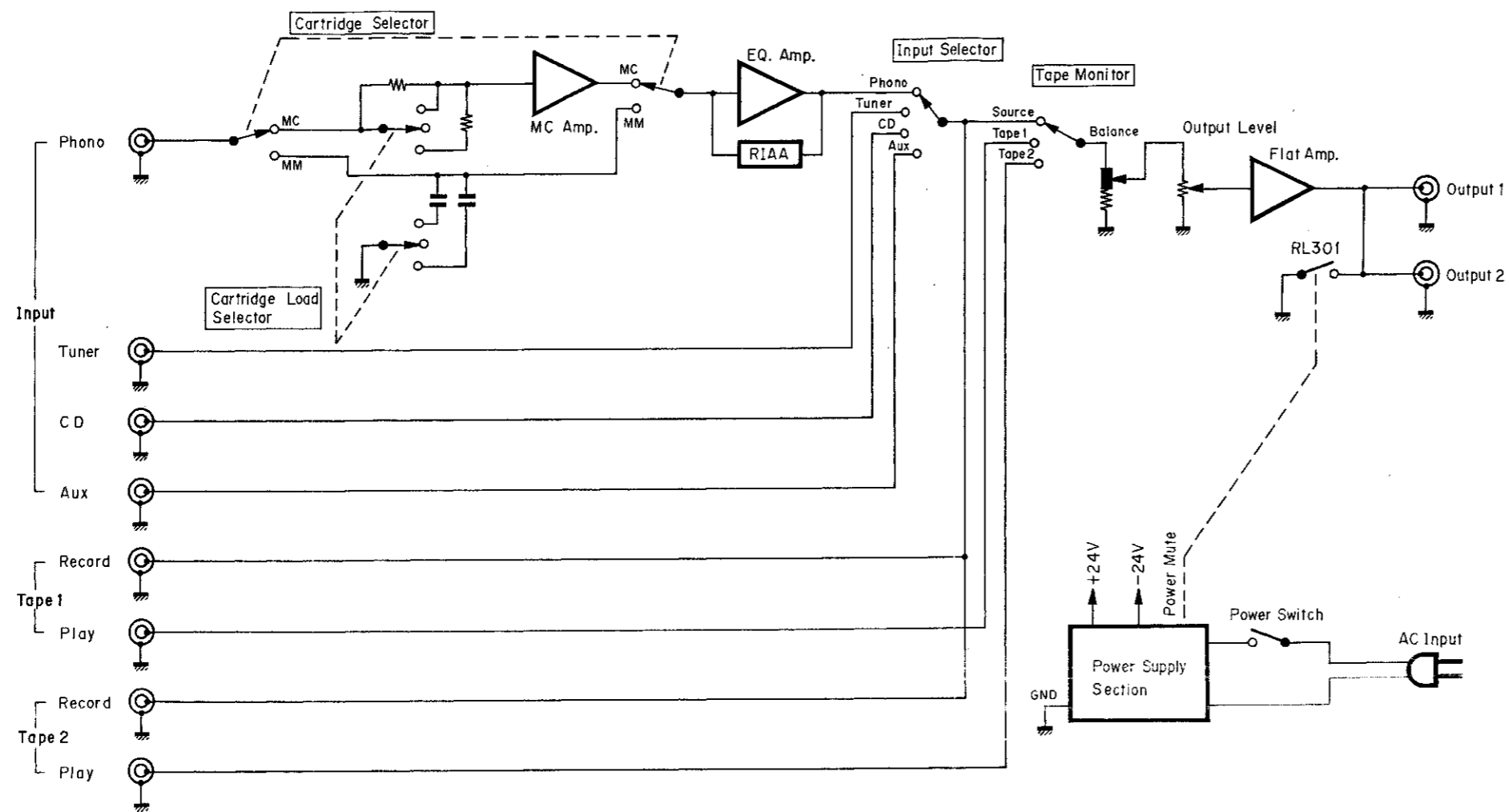

Fig. 8

9. SPECIFICATIONS

Input Sensitivity /Impedance/MC Head Amp. Gain	
Phono MC (50 ohms)	48 μ V/50 ohms/34 dB
(100 ohms)	76 μ V/100 ohms/30 dB
(200 ohms)	170 μ V/200 ohms/23 dB
Phono MM	2.4 mV/47 k ohms
Tuner/CD/Aux/Tape	200 mV/12.5 k ohms
Input Sensitivity (NEW IHF)	
Phono MC (50 ohms)	12 μ V
(100 ohms)	19 μ V
(200 ohms)	42.5 μ V
Phono MM	0.6 mV
Tuner/CD/Aux/Tape	50 mV
Maximum Input Level (1 kHz, Non Clipping Level, NEW IHF)	
Phono MC (50 ohms)	3 mV
(100 ohms)	5 mV
(200 ohms)	11 mV
Phono MM	170 mV
Output Level/Impedance	
Pre Out	2 V/1 k ohms
Rec Out	200 mV/1 k ohms
Maximum Output Level	16 V
(20–20,000 Hz, 1% THD, Pre Out, NEW IHF)	
Total Harmonic Distortion (20–20,000 Hz)	
Phono MC to Rec Out, 1 V	
(50 ohms)	Less than 0.005%
(200 ohms)	Less than 0.004%
Phono MM to Rec Out, 1 V .	Less than 0.002%
Tuner/CD/Aux/Tape to	
Pre Out, 2 V	Less than 0.002%
Frequency Response	
Tuner/CD/Aux/Tape	1.5–100,000 Hz +0, –3 dB
	20–20,000 Hz +0, –0.2 dB
RIAA Deviation	
Phono MM	30–20,000 Hz \pm 0.25 dB
	(0.5 dB at 20 Hz)
Phono MC	40–20,000 Hz \pm 0.25 dB
	(–0.7 dB at 20 Hz)
Signal to Noise Ratio (IHF A-WTD)	
Phono MC (0.5 mV Input, 0.5 V Pre Out, Input Shorted)	
(50 ohms)	Better than 78 dB
(100 ohms)	Better than 76 dB
(200 ohms)	Better than 72 dB
Phono MM (5 mV Input, . . .	Better than 81 dB
0.5 V Pre Out, Input	
Shorted)	
Tuner/CD/Aux/Tape	Better than 90 dB
(0.5 V Input, 0.5 V Pre Out,	
Input Shorted)	
Stereo Separation	
Phono MC (0.5 mV Input, 1 V Pre Out, Input Shorted)	
100 Hz/1 kHz/10 kHz	
(50 ohms)	85/80/65 dB
(200 ohms)	80/77/62 dB
Phono MM (5 mV Input, 1 V Pre Out, Input Shorted)	
100 Hz/1 kHz/10 kHz . . .	92/84/66 dB
Tuner/CD/Aux/Tape (0.5 V Input, 1 V Pre Out, Input Shorted)	
100 Hz/1 kHz/10 kHz . . .	110/93/74 dB
Remote Power On/Off	26 V DC
Control Output	
Power Source	120, 120/220-240, 220 or 240 V AC; 50/60 Hz
	(According to country of sale)
Power Consumption	15 W max.
Dimensions	435 (W) x 63 (H) x 289 (D) mm
	17-1/8 (W) x 2-1/2 (H) x 11-3/8 inches
Approximate Weight	3.7 kg; 8 lbs., 3 oz.
● Specifications and design are subject to change for further improvement without notice.	