



Service Manual

Nakamichi

CA-5^{II}

CA-5A^{II}

CA-5E^{II}

CA-50^{II}

Control Amplifier



CONTENTS

1. General	1
2. Removal Procedures	3
2. 1. Top Cover Ass'y	3
2. 2. Side Panel R and Side Panel L	3
2. 3. Main P.C.B. Ass'y	3
2. 4. Front Panel Ass'y	4
2. 5. Front Chassis and Tone Switch P.C.B. Ass'y	4
3. Parts Location for Electrical Adjustment	5
4. Electrical Adjustments	5
5. Mechanism Ass'y and Parts List	6
5. 1. Synthesis	6
5. 2. Chassis Ass'y (A01)	7
5. 3. Front Panel Ass'y (A02)	9
5. 4. Rear Panel Ass'y (B01)	9
5. 5. Main Chassis Ass'y (B02)	11
6. Mounting Diagrams and Parts List	12
6. 1. Power Switch P.C.B. Ass'y	12
6. 2. Power LED P.C.B. Ass'y	12
6. 3. Tone Switch P.C.B. Ass'y	12
6. 4. Pin Jack P.C.B. A Ass'y	13
6. 5. Pin Jack P.C.B. B Ass'y	13
6. 6. Pin Jack P.C.B. C Ass'y	13
6. 7. Load Switch P.C.B. Ass'y	14
6. 8. Volume P.C.B. Ass'y	14
6. 9. Tone Control P.C.B. Ass'y	14
6. 10. Main P.C.B. Ass'y	15
7. Schematic Diagram	17
8. Wiring Diagram	19
9. Block Diagram	21
10. Specifications	22

1. GENERAL

1.1. Voltage Selector

Voltage selector is installed on the rear panel of the Nakamichi CA-5II (Other version).
This voltage selector can select either 120 V or 220-240 V at customer's disposal.

1.2. Package Ass'y, Accessory Ass'y and Parts List

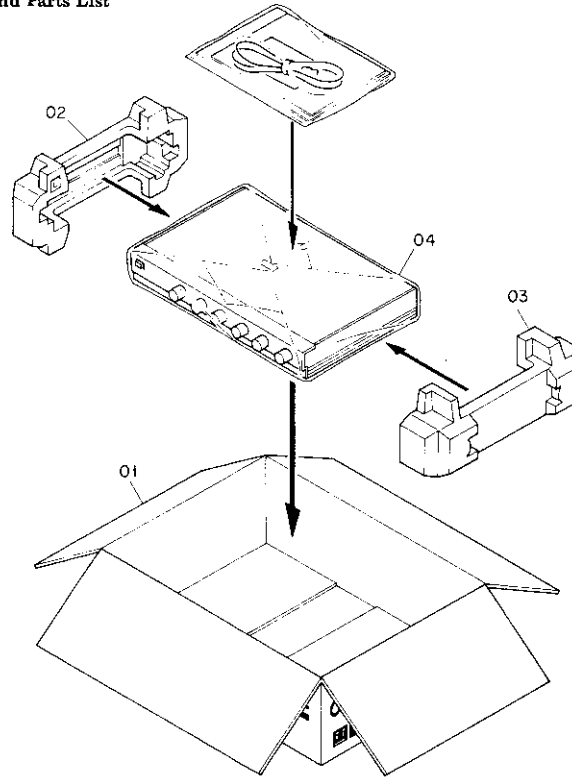

Fig. 1

Schematic Ref. No.	Part No.	Description	Q'ty	Schematic Ref. No.	Part No.	Description	Q'ty	
01	FA03627A	Package Ass'y (CA-5II (Other & Saudi Arabia))	1		0D04449A	Important Notice Card	1	
	FA03628A	Package Ass'y (CA-5II (Australia))	1		0D04766A	Catalogue (CA-5AII (U.S.A.))	1	
	FA03632A	Package Ass'y (CA-5AII (U.S.A.))	1		0D04797A	Warranty Card (CA-5AII (Canada))	1	
	FA03625A	Package Ass'y (CA-5AII (Canada))	1		0D04788A	Owner's Manual (Japanese)	1	
	FA03629A	Package Ass'y (CA-5EII (Europe, Germany & Switzerland))	1		0D04789A	Owner's Manual (English, German, French)	1	
	FA03624A	Package Ass'y (CA-5EII (UK))	1		0D04790A	Owner's Manual (English)	1	
	FA03626A	Package Ass'y (CA-50II (Japan))	1		0D04791A	Supplement for Resistor Kits (CA-5II (Australia) & CA-5AII (U.S.A.))	1	
	0F04081A	Carton Box CA-5II	1		0D04792A	Supplement for Resistor Kits (CA-5II (Other & Saudi Arabia), CA-5AII (Canada) & CA-5EII)	1	
	0F04082A	Carton Box CA-5AII	1		0D04793A	Supplement for Resistor Kits (CA-50II)	1	
	0F04079A	Carton Box CA-5EII	1		0D04794A	Price Card (CA-50II)	1	
	0F04080A	Carton Box CA-50II	1		0D04796A	Tape Catalogue (CA-5AII (U.S.A.))	1	
	02	0F03863A	Packing L		1	0F03887A	Power Cord Band (CA-5II (Saudi Arabia))	1
	03	0F03864B	Packing R		1	DA03873A	Warranty Card Ass'y (CA-5AII (U.S.A.), for 1st Version)	1
	04	0F03864A	Poly-Bag		1	0D04797A	Warranty Card Ass'y (CA-5AII (U.S.A.), for 2nd Version)	1
	—	0D04047A	User's Pack (CA-50II)		1	DA04116A	Resistor Kits (Except for CA-50II (Consisting of the followings:))	2
	—	0D04616A	Amp. Warranty Card (CA-50II)		1	(0B20417A)	RK 3.16 1/2W F	(1)
	—	0M03457A	Voltage Label 240V (CA-5II (Australia) & CA-5EII (UK))		2	(0B20418A)	RK 11.5 1/2W F	(1)
	—	0M03642A	Voltage Label 220/240V (CA-5II (Other & Saudi Arabia))		2	(0B20419A)	RK 26.1 1/2W F	(1)
	—	0M05060A	Point of Sale Label (CA-50II)		1	(0B20420A)	RK 42.2 1/2W F	(1)
		DA04109A	Accessory Ass'y (CA-5II (Other))		1	(0B20421A)	RK 100 1/2W G	(1)
DA04110A		Accessory Ass'y (CA-5II (Australia))	1	(0D04212A)	Poly-Bag	(1)		
DA04118A		Accessory Ass'y (CA-5II (Saudi Arabia))	1	DA04117A	Resistor Kits (CA-50II) (Consisting of the followings:)	2		
DA04114A		Accessory Ass'y (CA-5AII (U.S.A.))	1	(0B20164A)	RK 3.16 1/2W G	(1)		
DA04107A		Accessory Ass'y (CA-5AII (Canada))	1	(0B20169A)	RK 11.5 1/2W G	(1)		
DA04111A		Accessory Ass'y (CA-5EII (Europe, Germany & Switzerland))	1	(0B20186A)	RK 26.1 1/2W G	(1)		
DA04106A		Accessory Ass'y (CA-5EII (UK))	1	(0B20196A)	RK 42.2 1/2W G	(1)		
DA04108A		Accessory Ass'y (CA-50II)	1	(0B20214A)	RK 100 1/2W G	(1)		
0B90229A		Power Cord (CA-5II (Saudi Arabia))	1	(0D04212A)	Poly-Bag	(1)		
0B90222A		Power Cord (CA-5AII (U.S.A.))	1					
0D03092B		Poly-Bag for Accessory	1					

2. REMOVAL PROCEDURES

2.1. Top Cover Ass'y

Refer to Fig. 2.1.

- (1) Unfasten F01 (M4x8 Hex. Socket Head Screws) by using a wrench and remove F02 (Top Cover Ass'y).

2.2. Side Panel R and Side Panel L

Refer to Fig.2.2.

- (1) Remove the Top Cover Ass'y referring to item 2.1.
- (2) Unfasten F01, F02 and F03, and pull the front part of F04 (Side Panel R) to the right, then pull F04 (Side Panel R) forward to remove it.
- (3) Unfasten F05, F06 and F07, and pull the front part of F08 (Side Panel L) to the left, then pull F08 (Side Panel L) forward to remove it.

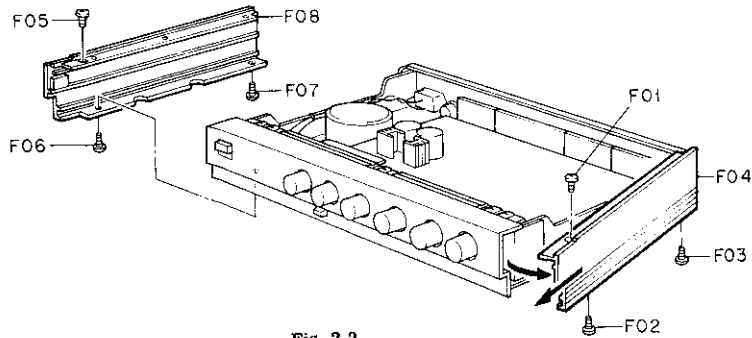

Fig. 2.2

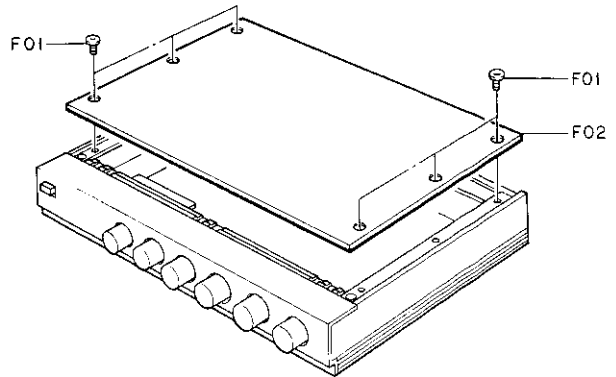

Fig. 2.1

2.3. Main P.C.B. Ass'y

Refer to Figs. 2.3.1 and 2.3.2.

- (1) Remove the Side Panel R and Side Panel L referring to item 2.2.
- (2) Unfasten F01, F02, F03 and F04.
- (3) Cut F05 (Insu-Lock) with pliers.
- (4) Lift F06 to gain access to the Main P.C.B. Ass'y.

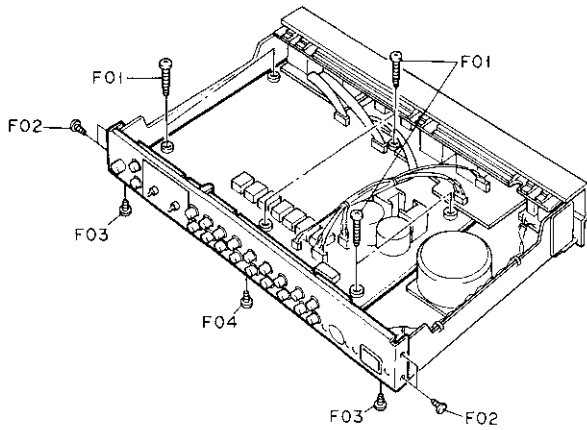

Fig. 2.3.1

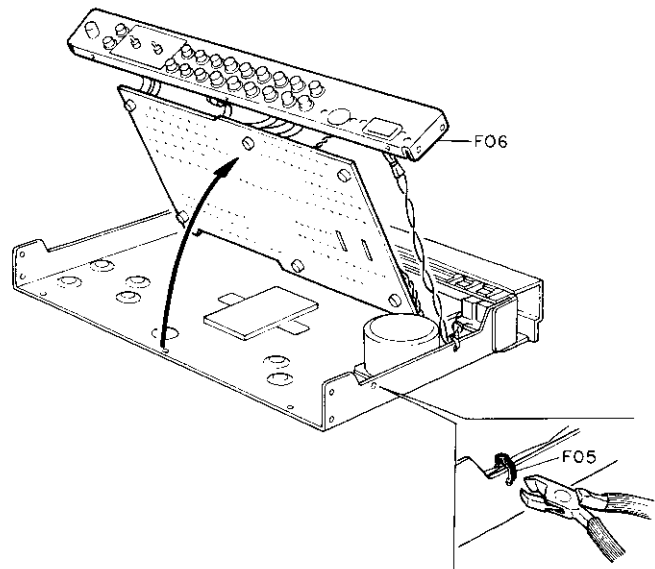

Fig. 2.3.2

2.4. Front Panel Ass'y

Refer to Fig. 2.4.

- (1) Remove the Side Panel R and Side Panel L referring to item 2.2.
- (2) Pull out F01 and unfasten F02, F03, F04 and F05.
- (3) Disconnect F06 and remove F07 (Front Panel Ass'y).

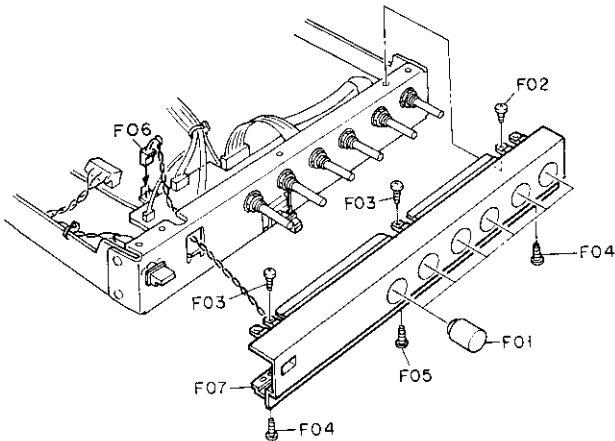

Fig. 2.4

2.5. Front Chassis and Tone Switch P.C.B. Ass'y

Refer to Figs. 2.5.1 and 2.5.2.

- (1) Remove the Front Panel Ass'y referring to item 2.4.
- (2) Unfasten F01, F02 and F03.
- (3) Remove F04 (Front Chassis), pull out F05, unfasten F06, and disassemble F07 (Tone Switch P.C.B. Ass'y).

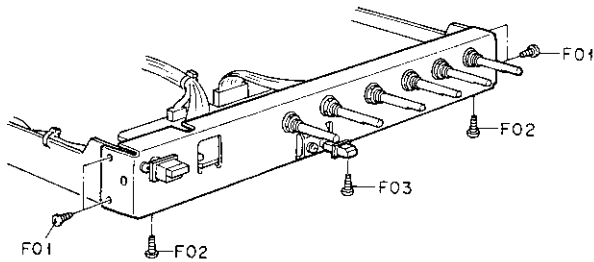

Fig. 2.5.1

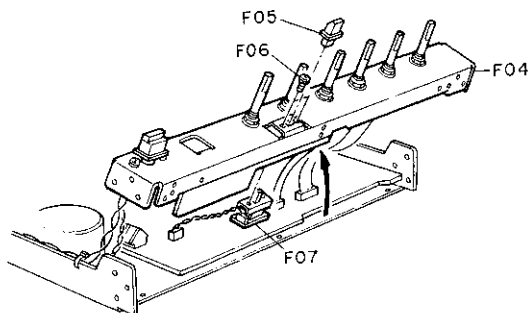

Fig. 2.5.2

3. PARTS LOCATION FOR ELECTRICAL ADJUSTMENT

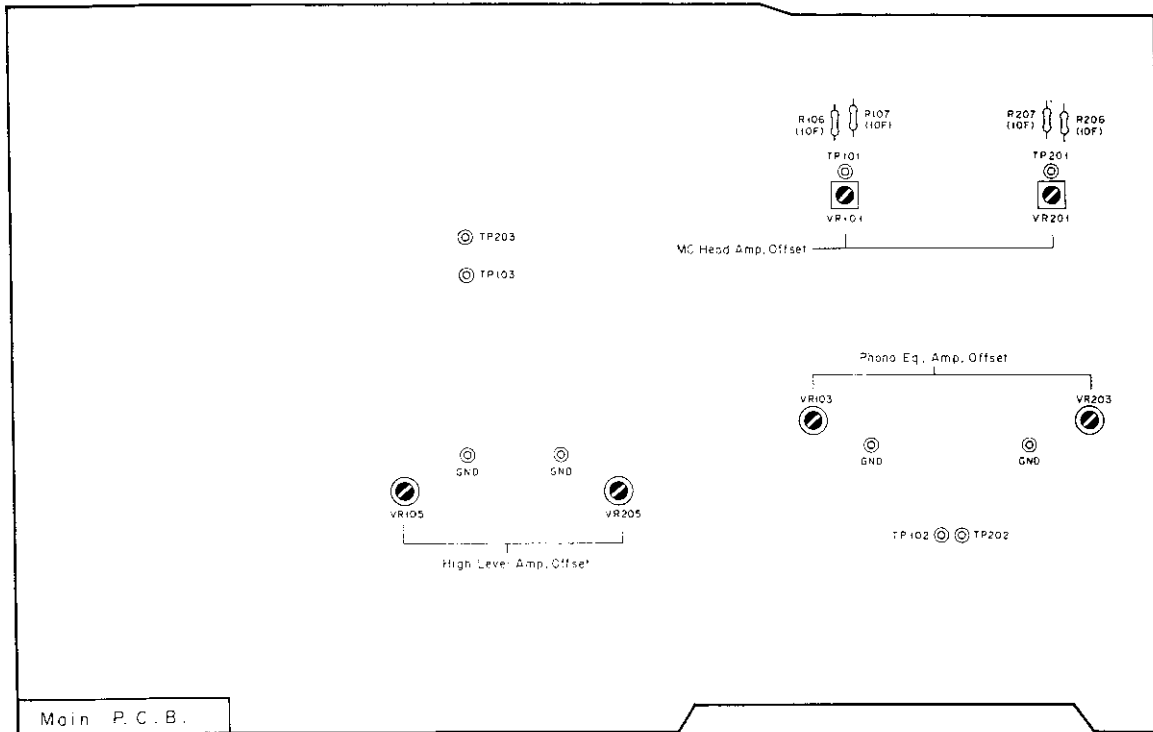

Fig. 3

4. ELECTRICAL ADJUSTMENTS

STEP	ITEM	OUTPUT CONNECTION	MODE	ADJUSTMENT	REMARKS
1	Preliminary Step		Output Level - Min. Input Selector - Phono Tone Switch - OFF Cartridge Selector - MM		1. Set the Control Amplifier as indicated in the MODE. 2. Remove all input/output signal cables from the Control Amplifier. 3. Turn ON the power and, with the Top Cover Ass'y installed, allow two minutes before adjusting. 4. Remove the Top Cover Ass'y referring to item 2.1.
2	MC Head Amp. Offset Adjustment	DC Voltmeter between TP101 (TP201) and GND on Main P.C.B.	Same as above	Main P.C.B. VR101 VR201 R107, R207 R106, R206	1. Adjust VR101 (VR201) to obtain 0 V \pm 2 mV on the DC voltmeter. 2. If satisfactory result is not obtained, short-circuit resistor R107 (R207) or R106 (R206) and re-adjust VR101 (VR201) once. R107 (R207): When reading in 1. exceeds 0 V +2 mV. R106 (R206): When reading in 1. is below 0 V -2 mV.
3	Phono Eq. Amp. Offset Adjustment	DC Voltmeter between TP102 (TP202) and GND on Main P.C.B.	Same as above	Main P.C.B. VR103 VR203	Adjust VR103 (VR203) to obtain 0 V \pm 1 mV on the DC voltmeter.
4	High Level Amp. Offset Adjustment	DC Voltmeter between TP103 (TP203) and GND on Main P.C.B.	Same as above	Main P.C.B. VR105 VR205	Adjust VR105 (VR205) to obtain 0 V \pm 1 mV on the DC voltmeter.

5. MECHANISM ASS'Y AND PARTS LIST

5.1. Synthesis

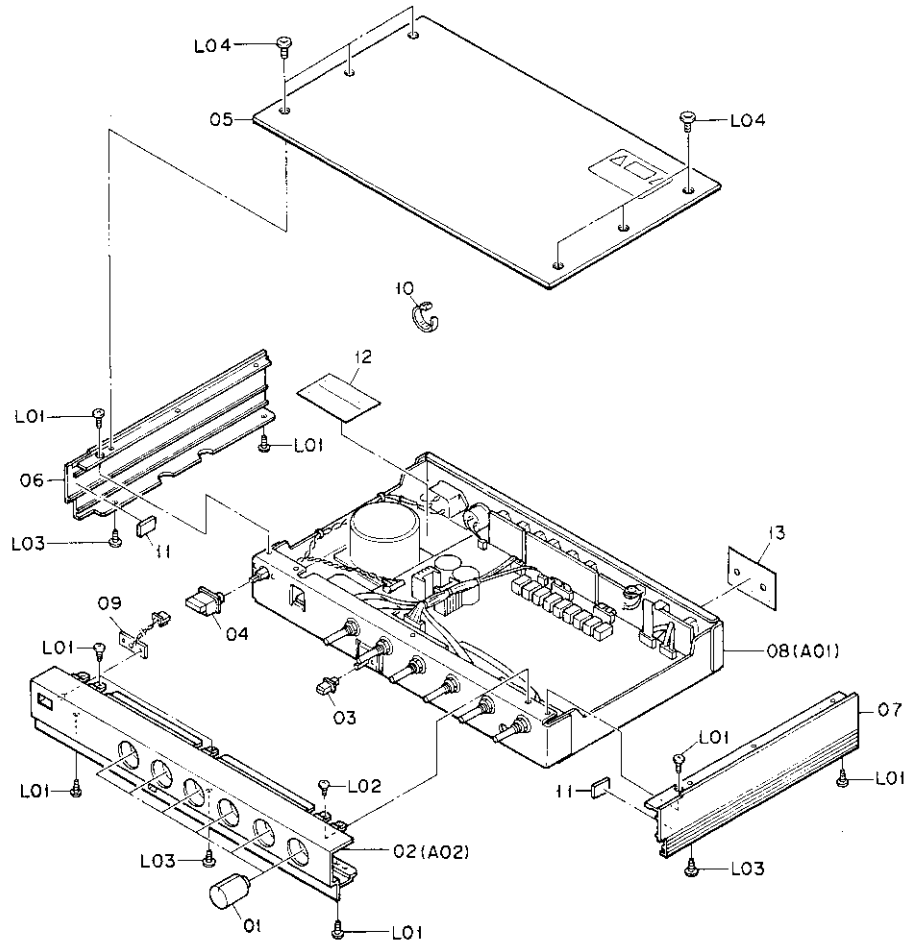

Fig. 5.1

Schematic Ref. No.	Part No.	Description	Q'ty	Schematic Ref. No.	Part No.	Description	Q'ty
5.1. Synthesis							
		Synthesis Serial No.: B10801001 -		09	JA04320A	Chassis Ass'y (CA-5II (UK))	1
				10	JA04322A	Chassis Ass'y (CA-50II)	1
				11	BA06995A	Power LED P.C.B. Ass'y	1
				12	OB08515A	Insu-Lock BK-1	1
				13	OJ05355A	BS Damper S 12x20	2
01	HA05126A	AFT Knob Ass'y	6		OM05062A	Fuse Caution (CA-5AII (Canada))	1
02	HA05325A	Front Panel Ass'y (CA-5II (Other, Australia & Saudi Arabia) & CA-5AII (Canada))	1		OM05072A	Caution Sheet (Except for CA-50II)	1
	HA05324A	Front Panel Ass'y (CA-5AII (U.S.A.))	1	L01	OM05073A	Caution Sheet (CA-50II)	1
	HA05326A	Front Panel Ass'y (CA-5EII)	1	L02	OE00921A	BT3x8 @ Binding (Black Chromate)	8
	HA05327A	Front Panel Ass'y (CA-50II)	1	L03	OE03013A	BT3x5 @ Binding	1
03	OH04643A	Push Button	1	L04	OE03366A	BT3x8 @ Binding Projected	3
04	HA04799B	Power Switch Button Ass'y	1		OE03431A	M4x8 Hex. Socket Head	6
05	HA05336A	Top Cover Ass'y (Consisting of the followings:)	1		OM03797A	Voltage Seal 240V (CA-5II (Australia) & CA-5EII (UK))	1
	(OH05153A)	Top Cover	(1)		OM03844B	Power Cord Label (CA-5EII (UK))	2
	(OJ05354A)	BS Damper TPJ	(1)		OM03917A	Production Date Seal (CA-5AII (U.S.A.))	1
	(OJ05409A)	Top Cover Cushion	(2)		OM04660A	Voltage Seal (CA-5II (Other & Saudi Arabia))	1
	(OJ05421A)	BS Damper F 20x20	(2)		OM05051A	Serial Number Seal	1
	(OM04377B)	Caution Sheet	(1)		OM05052A	FTZ Label (CA-5EII (Germany))	1
06	OH05150A	Side Panel L	1		OM05064A	EP Approval Label I (CA-5EII (Switzerland))	1
07	OH05151C	Side Panel R	1		OM05093A	EP Approval Label J (CA-5EII (Europe & Germany))	1
08	JA04326A	Chassis Ass'y (CA-5II (Other))	1		MA01001A	F. Code Label Ass'y	1
	JA04327A	Chassis Ass'y (CA-5II (Australia))	1		MA01002A	Multi-Label Ass'y (CA-50II)	1
	JA04325A	Chassis Ass'y (CA-5II (Saudi Arabia))	1		MA01003A	US Label Ass'y (CA-5AII (U.S.A.))	1
	JA04324A	Chassis Ass'y (CA-5AII (U.S.A.))	1				
	JA04323A	Chassis Ass'y (CA-5AII (Canada))	1				
	JA04321A	Chassis Ass'y (CA-5EII (Europe & Germany))	1				
	JA04328A	Chassis Ass'y (CA-5EII (Switzerland))	1				

5.2. Chassis Ass'y (A01)

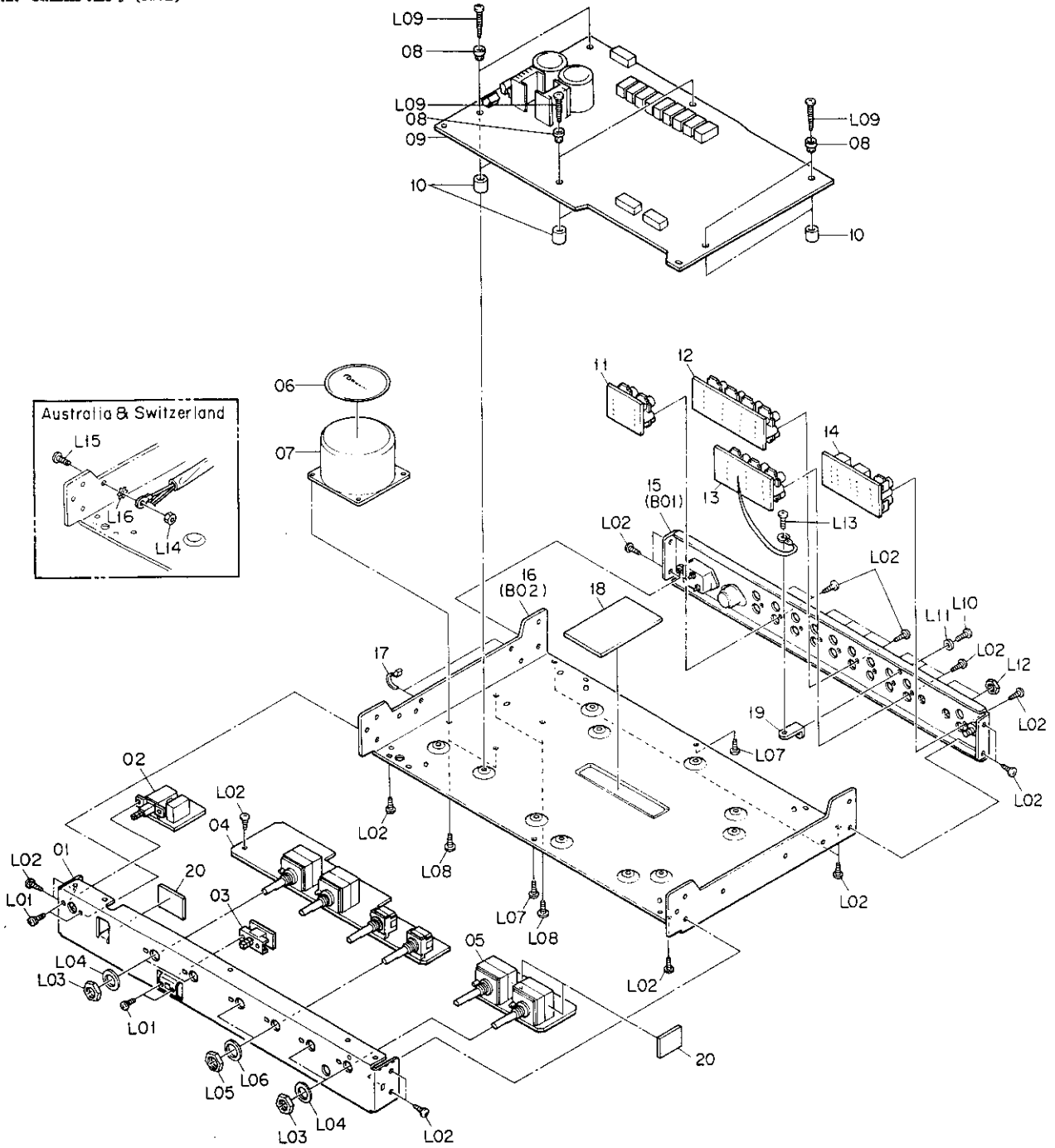

Fig. 5.2

Schematic Ref. No.	Part No.	Description	Qty	Schematic Ref. No.	Part No.	Description	Qty
5.2. Chassis Ass'y (A01)				L03	—	Nut for Volume	(4)
A01	JA04326A	Chassis Ass'y (CA-5II (Other))	1	L04	—	Washer for Volume	(4)
	JA04327A	Chassis Ass'y (CA-5II (Australia))	1	L05	—	Nut for Function Switch	(2)
	JA04325A	Chassis Ass'y (CA-5II (Saudi Arabia))	1	L06	—	Washer for Function Switch	(2)
	JA04324A	Chassis Ass'y (CA-5AII (U.S.A.))	1	L07	OE03366A	BT3x8 @ Binding Projected (Black Chromate)	2
	JA04323A	Chassis Ass'y (CA-5AII (Canada))	1	L08	OE00915A	BT4x8 @ Binding (Black Chromate)	4
	JA04321A	Chassis Ass'y (CA-5EII (Europe & Germany))	1	L09	OE03294A	BT3x18 @ Binding (Black Chromate)	6
	JA04328A	Chassis Ass'y (CA-5EII (Switzerland))	1	L10	OE00594A	M3x8 @ Binding	1
	JA04320A	Chassis Ass'y (CA-5EII (UK))	1	L11	OE03406A	Washer 3.2x5.7x1.2 (Copper Black Chromate)	1
	JA04322A	Chassis Ass'y (CA-50II) Serial No.: B10801001 -	1	L12	—	Nut for Load Switch	(2)
01	OJ05408B	Front Chassis	1	L13	OE03395A	M3x8 @ Binding (Copper)	1
02	BA06994A	Power Switch P.C.B. Ass'y (CA-5AII)	1	L14	OE00756A	M4x8 @ Binding (CA-5II (Australia) & CA-5EII (Switzerland))	1
	BA07139A	Power Switch P.C.B. Ass'y (CA-5II (Other))	1	L15	OE00669A	Nut Hex. M4 (CA-5II (Australia) & CA-5EII (Switzerland))	1
	BA07140A	Power Switch P.C.B. Ass'y (CA-5II (Australia) & Saudi Arabia) & CA-5EII	1	L16	OE00078A	Washer 4mm Toothed Lock (CA-5II (Australia) & CA-5EII (Switzerland))	1
	BA07141A	Power Switch P.C.B. Ass'y (CA-50II)	1	—	OM03700A	Earth Mark Label (CA-5II (Australia) & CA-5EII (Switzerland))	1
03	BA06991A	Tone Switch P.C.B. Ass'y	1				
04	BA06992A	Tone Control P.C.B. Ass'y	1				
05	BA06993A	Volume P.C.B. Ass'y	1				
06	OM04860A	Power Transformer Label	1				
07	OB50107A	Power Transformer (CA-5II (Other & Saudi Arabia))	1				
	OB50103A	Power Transformer (CA-5II (Australia) & CA-5EII (UK))	1				
	OB50106A	Power Transformer (CA-5AII)	1				
	OB50104A	Power Transformer (CA-5EII (Europe, Germany & Switzerland))	1				
	OB50105A	Power Transformer (CA-50II)	1				
08	OJ05019A	Coller Bushing A	6				
09	BA06986A	Main P.C.B. Ass'y (CA-5II (Other) & CA-5AII)	1				
	BA07124A	Main P.C.B. Ass'y (CA-5EII (Germany))	1				
	BA07123A	Main P.C.B. Ass'y (CA-5II (Australia & Saudi Arabia) & CA-5EII (Europe, Switzerland & UK))	1				
	BA07125A	Main P.C.B. Ass'y (CA-50II)	1				
10	OJ05020A	Coller Bushing B	6				
11	BA06989A	Pin Jack P.C.B. C Ass'y	1				
12	BA06988A	Pin Jack P.C.B. B Ass'y (Except CA-5EII (Germany))	1				
	BA07127A	Pin Jack P.C.B. B Ass'y (CA-5EII (Germany))	1				
13	BA06987A	Pin Jack P.C.B. A Ass'y (Except CA-5EII (Germany))	1				
	BA07126A	Pin Jack P.C.B. A Ass'y (CA-5EII (Germany))	1				
14	BA06990A	Load Switch P.C.B. Ass'y (Except CA-5EII (Germany))	1				
	BA07128A	Load Switch P.C.B. Ass'y (CA-5EII (Germany))	1				
15	HA05334A	Rear Panel Ass'y (CA-5II (Other))	1				
	HA05332A	Rear Panel Ass'y (CA-5II (Australia))	1				
	HA05346A	Rear Panel Ass'y (CA-5II (Saudi Arabia))	1				
	HA05329A	Rear Panel Ass'y (CA-5AII (U.S.A.))	1				
	HA05330A	Rear Panel Ass'y (CA-5AII (Canada))	1				
	HA05331A	Rear Panel Ass'y (CA-5EII (Europe & Germany))	1				
	HA05337A	Rear Panel Ass'y (CA-5EII (Switzerland))	1				
	HA05333A	Rear Panel Ass'y (CA-5EII (UK))	1				
	HA05328A	Rear Panel Ass'y (CA-50II)	1				
16	HA05335A	Main Chassis Ass'y	1				
17	OB08515A	Insu-Lock BK-1 (CA-5II (Other & Australia), CA-5AII (Canada) & CA-5EII & CA-50II)	7				
	OB08515A	Insu-Lock BK-1 (CA-5II (Saudi Arabia) & CA-5AII (U.S.A.))	8				
18	OJ05354A	BS Damper TPJ	1				
19	OJ05246A	Ground Bracket	1				
20	OJ05421A	BS Damper F 20x20	3				
L01	OE00612A	M3x6 @ Pan (2A)	4				
L02	OE00921A	BT3x8 @ Binding (Black Chromate)	23				

5.3. Front Panel Ass'y (A02)

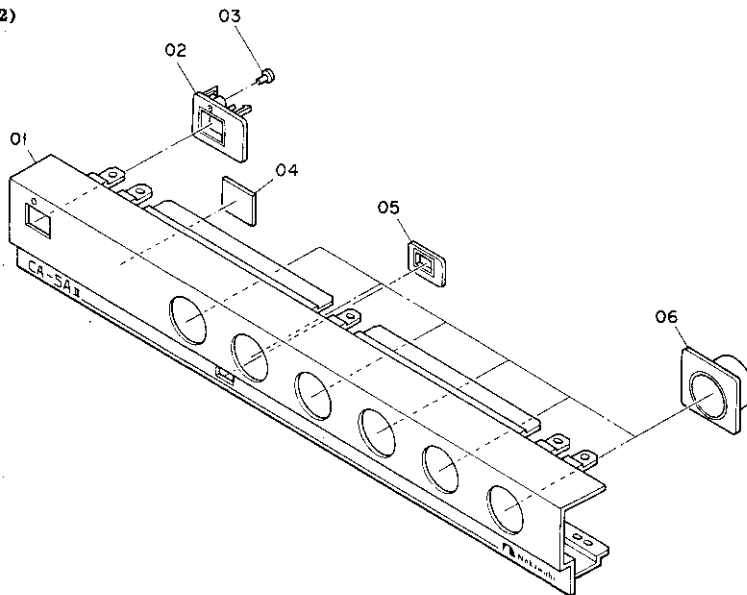

Fig. 5.3

5.4. Rear Panel Ass'y (B01)

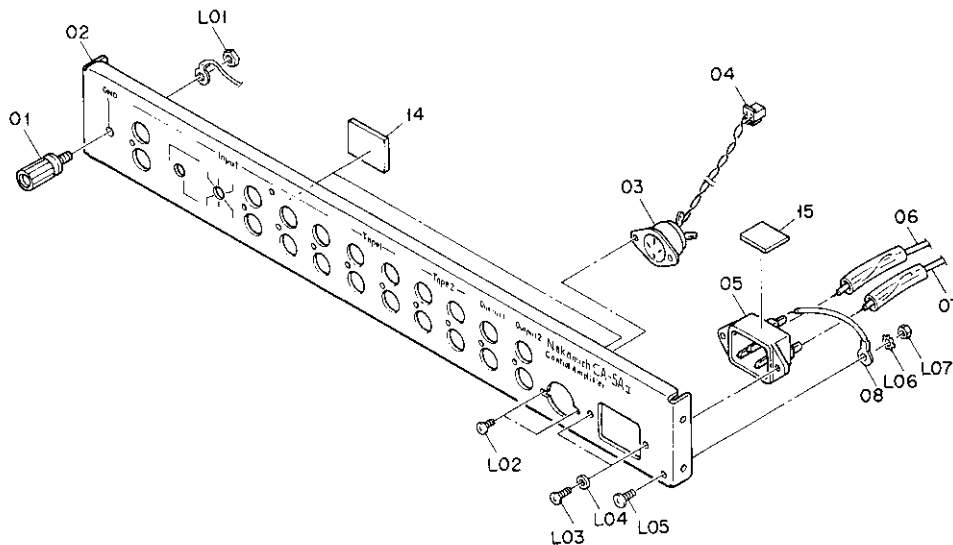
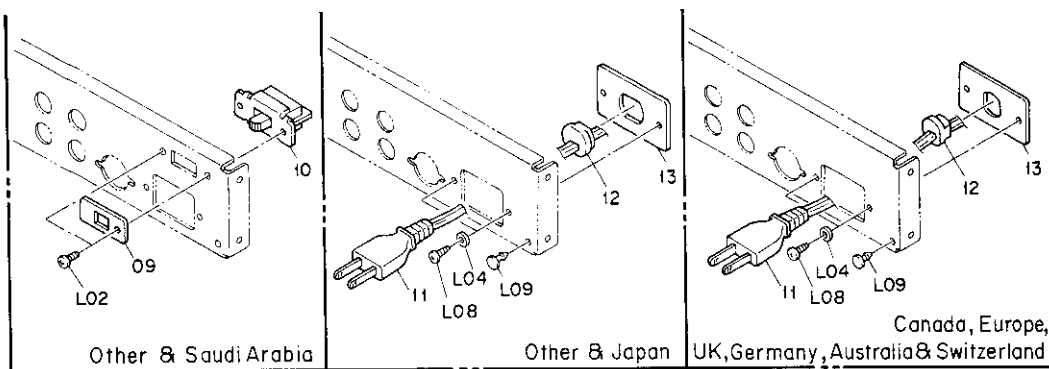

Fig. 5.4

Schematic Ref. No.	Part No.	Description	Q'ty	Schematic Ref. No.	Part No.	Description	Q'ty	
5.3. Front Panel Ass'y (A02)				14	0J05355A	BS Damper S 12x20	2	
A02	HA05325A	Front Panel Ass'y (CA-5II & CA-5AII (Canada))	1	15	0J05355A	BS Damper S 12x20 (CA-5II Saudi Arabia) & CA-5AII (U.S.A.)	1	
	HA05324A	Front Panel Ass'y (CA-5AII (U.S.A.))	1	L01	—	Nut for Ground Terminal	(1)	
	HA05326A	Front Panel Ass'y (CA-5EII)	1	L02	0E00985A	M3x6 @ Binding (Black Chromate) (CA-5II (Australia), CA-5AII, CA-5EII & CA-50II)	2	
	HA05327A	Front Panel Ass'y (CA-50II) Serial No.: B10801001 -	1		0E00985A	M3x6 @ Binding (Black Chromate) (CA-5II (Other & Saudi Arabia))	4	
01	0H05156A	Front Panel (CA-5II & CA-5AII (Canada))	1	L03	0E00594A	M3x8 @ Binding (CA-5II (Saudi Arabia) & CA-5AII (U.S.A.))	2	
	0H05155A	Front Panel (CA-5AII (U.S.A.))	1	L04	0E03406A	Washer 3.2x5.7x1.2 (Copper Black Chromate)	2	
	0H05157A	Front Panel (CA-5EII)	1	L05	0E00756A	M4x8 @ Binding (CA-5II (Saudi Arabia) & CA-5AII (U.S.A.))	1	
02	0H05158A	Front Panel (CA-50II)	1	L06	0E00078A	Washer 4mm Toothed Lock (CA-5II (Saudi Arabia) & CA-5AII (U.S.A.))	1	
	0J05218A	Power Button Guide	1	L07	0E00669A	Nut Hex, M4 (CA-5II (Saudi Arabia) & CA-5AII (U.S.A.))	1	
03	0H04639B	Lens	1	L08	0E00921A	BT3x8 @ Binding (Black Chromate) (CA-5II (Other & Australia) & CA-5AII (Canada) & CA-5EII & CA-50II)	2	
04	0J05421A	BS Damper F 20x20	1	L09	0J05108A	Hole Plug (CA-5II (Other & Australia), CA-5AII (Canada), CA-5EII & CA-50II)	1	
05	0H05154A	Push Button Guide	1	—	0M03700A	Earth Mark Label (CA-5II (Saudi Arabia) & CA-5AII (U.S.A.))	1	
06	0H04648B	Volume Knob Holder	6					
5.4. Rear Panel Ass'y (B01)								
B01	HA05334A	Rear Panel Ass'y (CA-5II (Other))	1					
	HA05332A	Rear Panel Ass'y (CA-5II (Australia))	1					
	HA05346A	Rear Panel Ass'y (CA-5II (Saudi Arabia))	1					
	HA05329A	Rear Panel Ass'y (CA-5AII (U.S.A.))	1					
	HA05330A	Rear Panel Ass'y (CA-5AII (Canada))	1					
	HA05331A	Rear Panel Ass'y (CA-5EII (Europe & Germany))	1					
	HA05337A	Rear Panel Ass'y (CA-5EII (Switzerland))	1					
	HA05333A	Rear Panel Ass'y (CA-5EII (UK))	1					
	HA05328A	Rear Panel Ass'y (CA-50II) Serial No.: B10801001 -	1					
	01	0B81685A	Ground Terminal T5435	1				
02	0H05164B	Rear Panel (CA-5II (Other & Saudi Arabia))	1					
	0H05161B	Rear Panel (CA-5II (Australia))	1					
	0H05160B	Rear Panel (CA-5AII (U.S.A.))	1					
	0H05223A	Rear Panel (CA-5AII (Canada))	1					
	0H05162B	Rear Panel (CA-5EII)	1					
	0H05159B	Rear Panel (CA-50II)	1					
	03	0B81372A	DIN Socket 3P	1				
	04	0B83108A	2P Connector	1				
	05	0B90087A	AC Inlet NC-173 (CA-5II (Saudi Arabia) & CA-5AII (U.S.A.))	1				
		0B83153A	AC Cord (White) (CA-5II (Saudi Arabia))	2				
06	0B83153A	AC Cord (White) (CA-5AII (U.S.A.))	1					
	0B83154A	AC Cord (Black) (CA-5II (Saudi Arabia))	2					
07	0B83154A	AC Cord (Black) (CA-5AII (U.S.A.))	1					
	0B80101A	Ground Cable with Lug Terminal (CA-5II (Saudi Arabia) & CA-5AII (U.S.A.))	1					
08	0M03948A	Voltage Selector Lock Plate (CA-5II (Other & Saudi Arabia))	1					
09	0B07092U	Voltage Selector ESD396 (CA-5II (Other & Saudi Arabia))	1					
10	0B80085A	Power Cord (OFC) (CA-5II (Other) & CA-50II)	1					
	0B80133B	Power Cord SA (CA-5II (Australia))	1					
11	0B80131A	Power Cord (OFC) (CA-5AII (Canada))	1					
	0B80124A	Power Cord VDE (CA-5EII (Europe & Germany))	1					
12	0B80132B	Power Cord SV (CA-5EII (Switzerland))	1					
	0B80134A	Power Cord BS (CA-5EII (UK))	1					
13	0B90186A	Cord Bushing SR-33-1 (SPT-3) (CA-5II (Other) & CA-50II)	1					
	0B90157A	Cord Bushing SR-6N-4 18/2 (CA-5II (Australia), CA-5AII (Canada) & CA-5EII)	1					
13	0H05181A	Bushing Holder (CA-5II (Other) & CA-50II)	1					
	0H04772A	Bushing Holder (CA-5II (Australia), CA-5AII (Canada) & CA-5EII)	1					

5.5. Main Chassis Ass'y (B02)

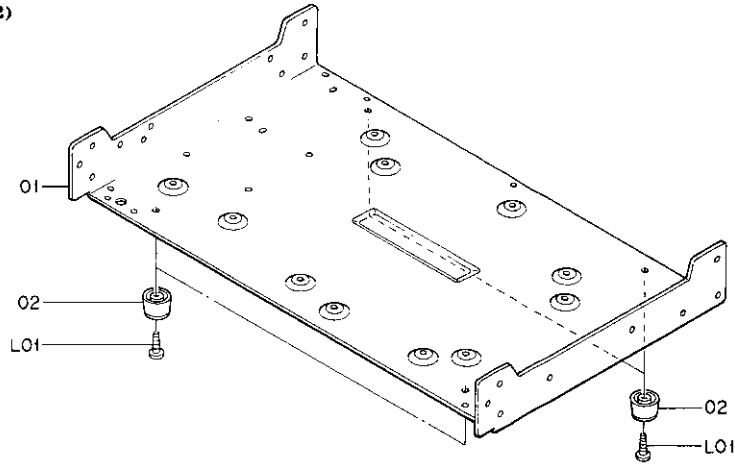

Fig. 5.5

Schematic Ref. No.	Part No.	Description	Qty
5.5. Main Chassis Ass'y (B02)			
B02	HA05335A	Main Chassis Ass'y Serial No.: B10801001 -	1
01	OH05152A	Main Chassis	1
02	OJ05162A	Leg T-S	4
L01	OE00888A	BT3x12 ⊕ Binding	4

6. MOUNTING DIAGRAMS AND PARTS LIST

- Notes: 1. Mounting diagram shows a dip side view of the printed circuit board.
 2. Diode is 1SS53, 1S1555, or 1SS176 unless otherwise specified.
 3. Following transistors are interchangeable with each other.
 2SC945, 2SC536SP, 2SC2458, 2SC2785
 4. Abbreviation for part name:
 TR — Transistor, SID — Silicon Diode, ZD — Zener Diode
 RK — Carbon Resistor, RM — Metal Film Resistor, RF — Fail Safe Type Resistor
 CE — Electrolytic Capacitor, CML — Mylar Capacitor, CC — Ceramic Capacitor, CPP — PP Capacitor,
 CMM — Metalized Mylar Capacitor, CSP — Polystyrene Capacitor, C — Mica Capacitor

6.1. Power Switch P.C.B. Ass'y

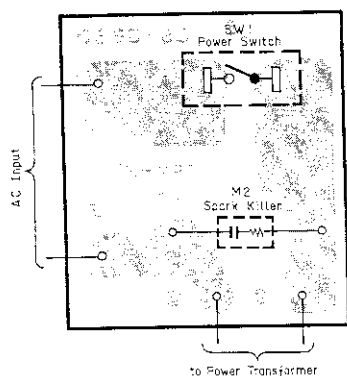

Fig. 6.1

6.2. Power LED P.C.B. Ass'y

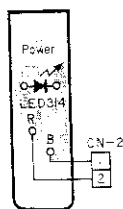

Fig. 6.2

6.3. Tone Switch P.C.B. Ass'y

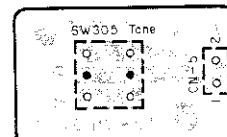

Fig. 6.3

Schematic Ref. No.	Part No.	Description	Schematic Ref. No.	Part No.	Description
6.1. Power Switch P.C.B. Ass'y			6.2. Power LED P.C.B. Ass'y		
	BA06994A	Power Switch P.C.B. Ass'y (CA-5AII)		BA06995A	Power LED P.C.B. Ass'y
	BA07139A	Power Switch P.C.B. Ass'y (CA-5II (Other))	LED314	OB60485A	Power LED P.C.B.
	BA07140A	Power Switch P.C.B. Ass'y (CA-5II (Australia & Saudi Arabia) & CA-5EII)	CN2	OB12215A	LED SLP202C Green
	BA07141A	Power Switch P.C.B. Ass'y (CA-50II)		OB82816A	2P Connector
	OB60483B	Power Switch P.C.B.	6.3. Tone Switch P.C.B. Ass'y		
SW1	OB71006A	Power Switch SDL1P	SW305	BA06991A	Tone Switch P.C.B. Ass'y
M2	OB90232A	Spark Killer XE-473 (CA-5II & CA-5EII)	CN5	OB60484A	Tone Switch P.C.B.
M2	OB08342A	Spark Killer ECQ-JC187C (CA-5AII)		OB70118A	Push Switch
M2	OB08363A	Spark Killer AU 120033 (CA-50II)		OB83106A	2P Connector
	OB90019A	Insu-Lock SKB8080x1.9 (4)			
	OE00752A	Eyelet 2x3 (CA-5II (Australia & Saudi Arabia) & CA-5EII) (2)			

6.4. Pin Jack P.C.B. A Ass'y

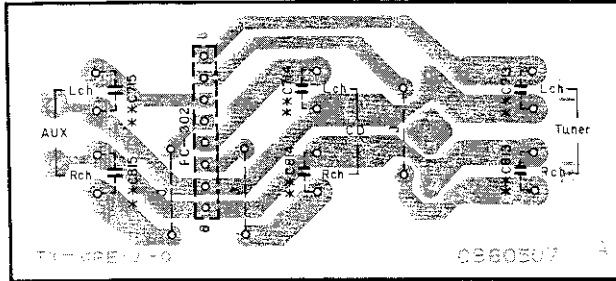

Fig. 6.4 **: CA-5EII (Germany) only.

6.5. Pin Jack P.C.B. B Ass'y

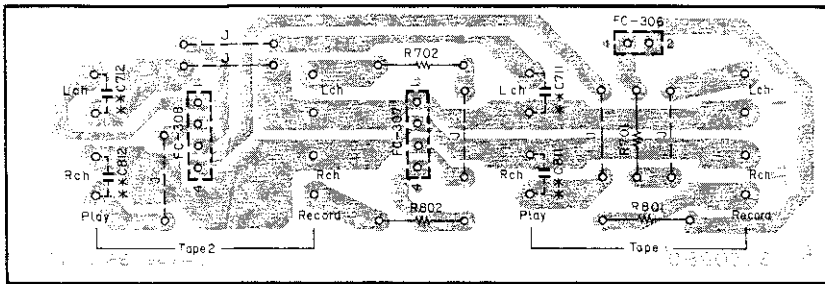

Fig. 6.5 **: CA-5EII (Germany) only.

6.6. Pin Jack P.C.B. C Ass'y

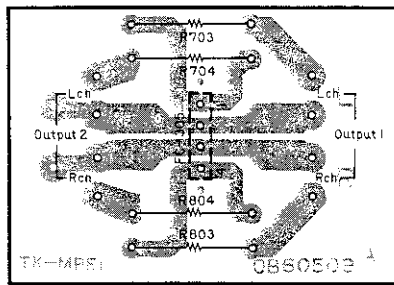

Fig. 6.6

Schematic Ref. No.	Part No.	Description
6.4. Pin Jack P.C.B. Ass'y		
	BA06987A	Pin Jack P.C.B. A Ass'y (Except CA-5EII (Germany))
	BA07126A	Pin Jack P.C.B. A Ass'y (CA-5EII (Germany))
C713	OB60507A OB41816A	Pin Jack P.C.B. A CSP 220P 160V J (CA-5EII (Germany))
C714,715	OB41754A	CSP 150P 160V J (CA-5EII (Germany))
C813	OB41816A	CSP 220P 160V J (CA-5EII (Germany))
C814,815	OB41754A	CSP 150P 160V J (CA-5EII (Germany))
FC302	OB81019A OB81374A	8P Dip Mate WH8D-1 2P Pin Jack (3)
6.5. Pin Jack P.C.B. B Ass'y		
	BA06988A	Pin Jack P.C.B. B Ass'y (Except CA-5EII (Germany))
	BA07127A	Pin Jack P.C.B. B Ass'y (CA-5EII (Germany))
R701,702	OB60508A	Pin Jack P.C.B. B RM 1K 1/4W F
R801,802	OB09491A	RM 1K 1/4W F
C711,712	OB09844A	CML 1000P 50V J (CA-5EII (Germany))
C811,812	OB09844A	CML 1000P 50V J (CA-5EII (Germany))
FC306	OB81002A	2P Dip Mate WH2D-1
FC307,308	OB81011A OB81374A	4P Dip Mate WH4D-1 2P Pin Jack (4)
6.6. Pin Jack P.C.B. C Ass'y		
	BA06989A	Pin Jack P.C.B. C Ass'y
R703,704	OB60509A	Pin Jack P.C.B. C RK 470 1/2W G
R803,804	OB20422A	RK 470 1/2W G
FC305	OB81011A OB81374A	4P Dip Mate WH4D-1 2P Pin Jack (2)
6.7. Load Switch P.C.B. Ass'y		
	BA06990A	Load Switch P.C.B. Ass'y (Except CA-5EII (Germany))
	BA07128A	Load Switch P.C.B. Ass'y (CA-5EII (Germany))
L701	OB60510B OB51265A	Load Switch P.C.B. Coil 30μH (CA-5EII (Germany))
L702	OB51266A	Coil 48μH (CA-5EII (Germany))
L801	OB51265A	Coil 30μH (CA-5EII (Germany))
L802	OB51266A	Coil 48μH (CA-5EII (Germany))
C701	OB41764A	CSP 100P 160V J
C702	OB41765A	CSP 200P 160V J
C709	OB41823A	CMM 0.01μ 50V J
C710	OB41764A	CSP 100P 160V J (CA-5EII (Germany))
C801	OB41764A	CSP 100P 160V J
C802	OB41765A	CSP 200P 160V J
C809	OB41823A	CMM 0.01μ 50V J
C810	OB41764A	CSP 100P 160V J (CA-5EII (Germany))
SW301	OB70120A	Toggle Switch 8J4022
SW302	OB70119A	Toggle Switch 8J4012
FC101	OB81014A	7P Dip Mate WH7D-1
FC201	OB81014A OB81374A 0J05414B	7P Dip Mate WH7D-1 2P Pin Jack (1) Spacer (1)

6.7. Load Switch P.C.B. Ass'y

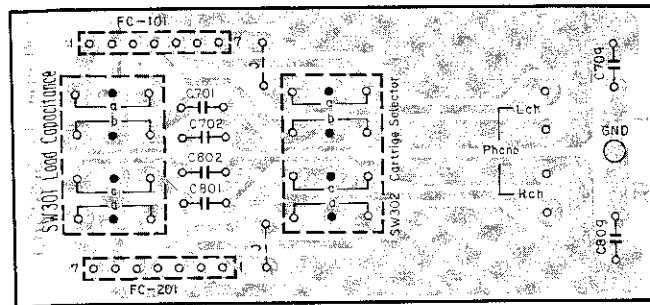

Fig. 6.7.1 Except for CA-5EII (Germany)

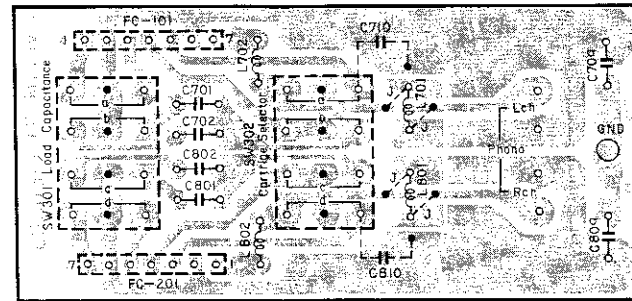

Fig. 6.7.2 For CA-5EII (Germany)

6.8. Volume P.C.B. Ass'y

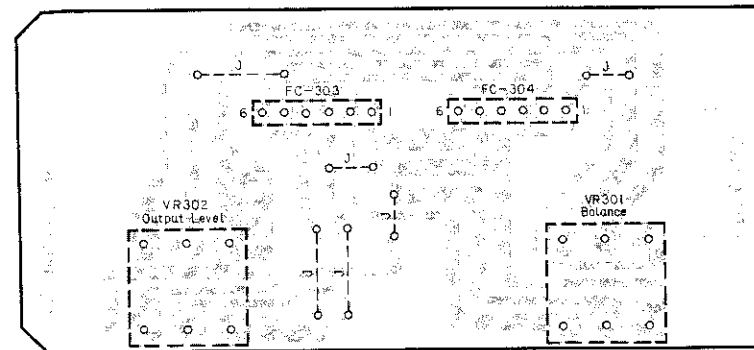

Fig. 6.8

6.9. Tone Control P.C.B. Ass'y

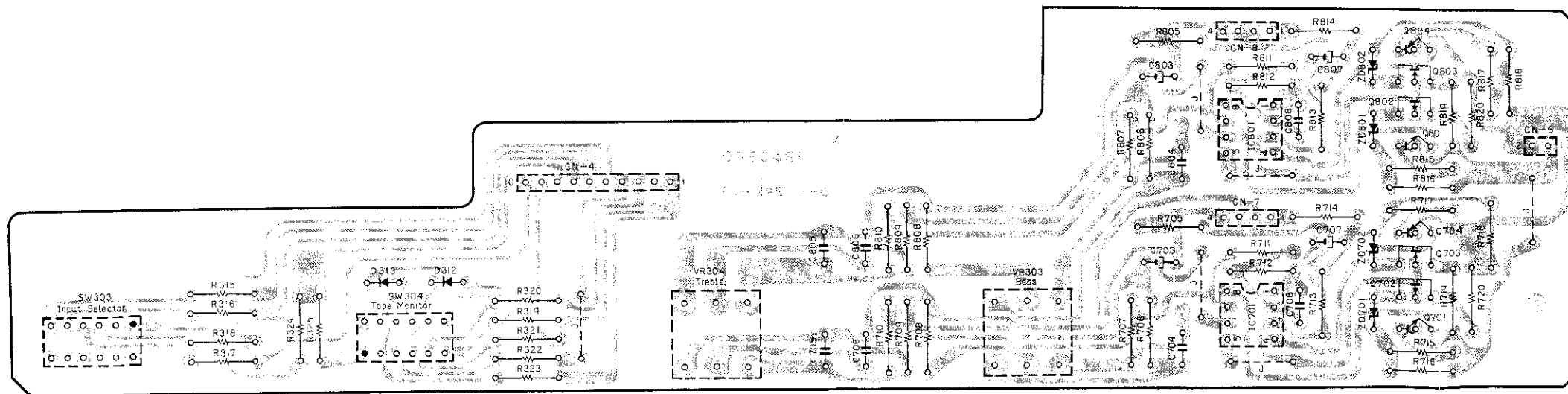
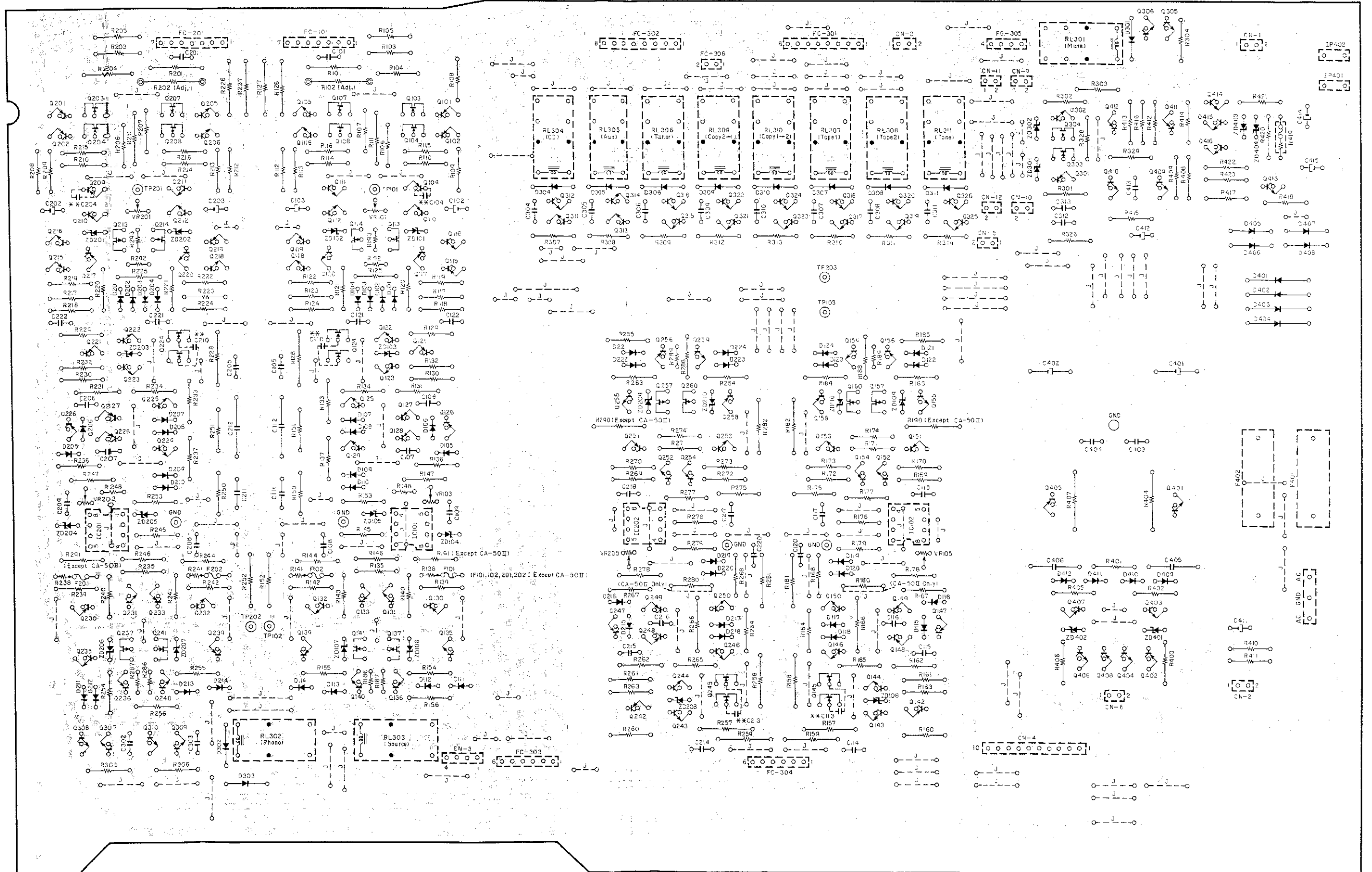

Fig. 6.9

Schematic Ref. No.	Part No.	Description
6.8. Volume P.C.B. Ass'y		
	BA06993A	Volume P.C.B. Ass'y
VR301	OB60482B	Volume P.C.B.
VR302	OB30083A	VR 20Kx2
FC303,304	OB30084A	VR 50Kx2
	OB81013A	6P Dip Mate
6.9. Tone Control P.C.B. Ass'y		
	BA06992A	Tone Control P.C.B. Ass'y
IC701	OB60481A	Tone Control P.C.B.
IC801	OB11204A	IC NJM5532DD
Q701	OB11204A	IC NJM5532DD
Q702	OB06142A	TR 2SC2240 (BL)
Q703	OB10169A	FET 2SJ74 (BL)
Q704	OB10112A	FET 2SK170 (BL)
Q801	OB10050A	TR 2SA970 (BL)
Q802	OB06142A	TR 2SC2240 (BL)
Q803	OB10169A	FET 2SJ74 (BL)
Q804	OB10112A	FET 2SK170 (BL)
ZD701,702	OB10050A	TR 2SA970 (BL)
	OB12183A	ZD 16V
ZD801,802	OB12183A	RD16JS-T1B2 RD16V
D312,313	OB06398A	SD 1SS176
VR303	OB30081A	VR 20KBx2
VR304	OB30082A	VR 100KBx2
R315,316	OB05776A	RK 1M 1/4W J
R317,318	OB05776A	RK 1M 1/4W J
R319,320	OB05776A	RK 1M 1/4W J
R321,322	OB05776A	RK 1M 1/4W J
R323	OB05776A	RK 1M 1/4W J
R324,325	OB05625A	RK 220K 1/4W J
R705	OB09305A	RM 100K 1/4W F
R706,707	OB22669A	RM 7.50K 1/4W F
R708	OB25489A	RM 16.2K 1/4W F
R709,710	OB22669A	RM 7.50K 1/4W F
R711,712	OB09491A	RM 1K 1/4W F
R713	OB09305A	RM 100K 1/4W F
R714	OB22567A	RM 100 1/4W F
R715	OB09547A	RM 2.21K 1/4W F
R716	OB22729A	RM 10.0K 1/4W F
R717	OB09547A	RM 2.21K 1/4W F
R718	OB22729A	RM 10.0K 1/4W F
R719,720	OB09427A	RM 5.62K 1/4W F
R805	OB09305A	RM 100K 1/4W F
R806,807	OB22669A	RM 7.50K 1/4W F
R808	OB25489A	RM 16.2K 1/4W F
R809,810	OB22669A	RM 7.50K 1/4W F
R811,812	OB09491A	RM 1K 1/4W F
R813	OB09305A	RM 100K 1/4W F
R814	OB22567A	RM 100 1/4W F
R815	OB09547A	RM 2.21K 1/4W F
R816	OB22729A	RM 10.0K 1/4W F
R817	OB09547A	RM 2.21K 1/4W F
R818	OB22729A	RM 10.0K 1/4W F
R819,820	OB09427A	RM 5.62K 1/4W F
C703	OB40376A	CE 10μ 16V (LN)
C704	OB41819A	CMM 0.18μ 50V
C705	OB41816A	CSP 220P 160V J
C706	OB41817A	CSP 510P 160V J
C707	OB40376A	CE 10μ 16V (LN)
C708	OB41817A	CSP 510P 160V J
C803	OB40376A	CE 10μ 16V (LN)
C804	OB41819A	CMM 0.18μ 50V J
C805	OB41816A	CSP 220P 160V J
C806	OB41817A	CSP 510P 160V J
C807	OB40376A	CE 10μ 16V (LN)
C808	OB41817A	CSP 510P 160V J
SW303	OB70047A	Rotary Switch 4P
SW304	OB70117A	Rotary Switch 5P
CN4	OB83105A	10P Connector
CN6	OB83107A	2P Connector Ass'y
CN7	OB83103A	Tone L Cord Ass'y
CN8	OB83104A	Tone R Cord Ass'y

6.10. Main P.C.B. Ass'y



** : CA-5EII (Germany) only.

Fig. 6.10

7. SCHEMATIC DIAGRAM

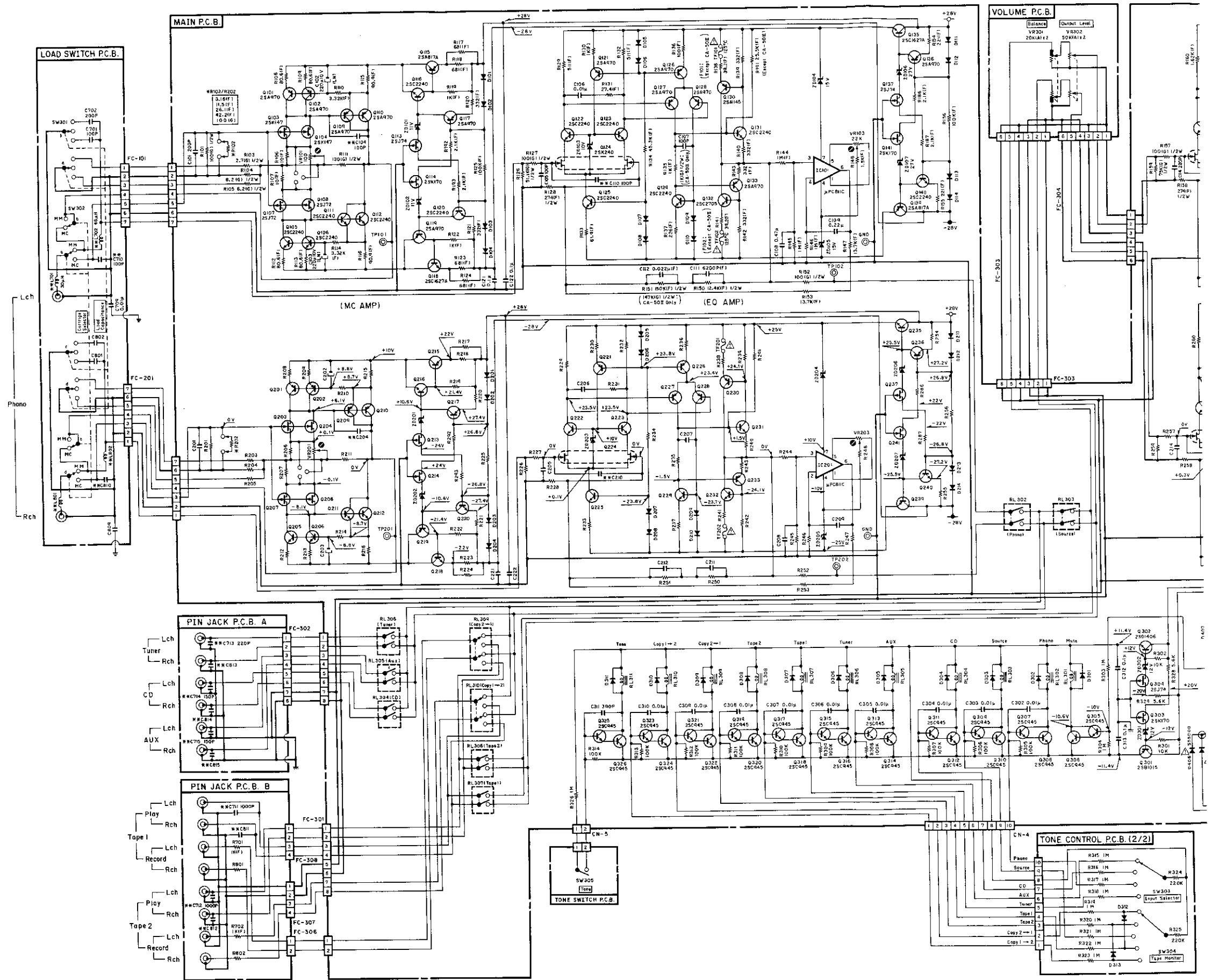
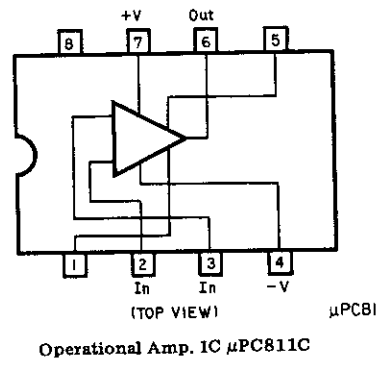
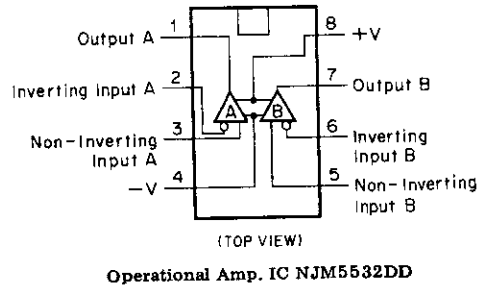
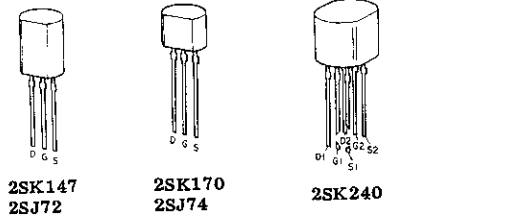
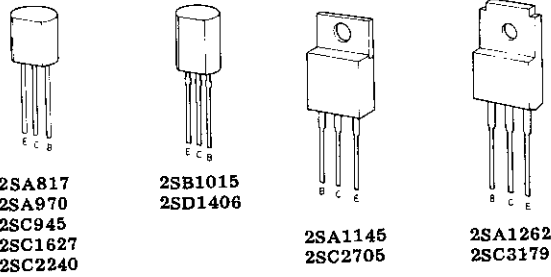

Fig. 7.1

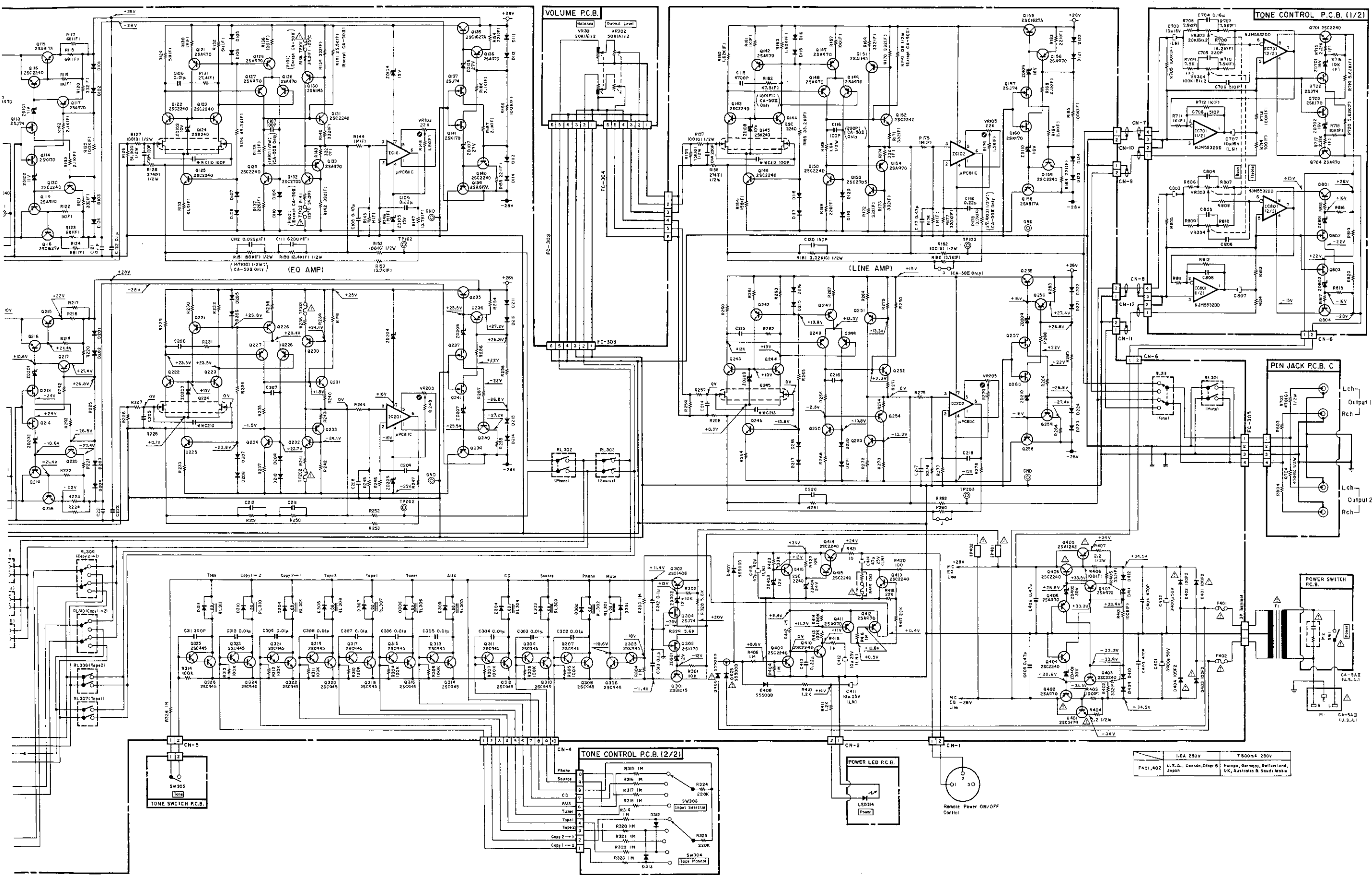



Fig. 7.1

- Notes: 1. Diode is 1SS53, 1S1555, or 1SS176 unless otherwise specified.
 2. Resistor and capacitor marked with * show typical value.
 3. Parts marked with ** are mounted only for CA-5EII (Germany).
 4. 2SC945, 2SC536SP, 2SC2458 and 2SC2785 are interchangeable with each other.

WARNING:

Parts marked with the symbol  have critical characteristics. Use ONLY replacement parts recommended by the manufacturer. It is recommended that the unit be operated from a suitable DC supply or batteries during initial check-out procedures.

CAUTION:

Before returning the unit to the customer, make sure you make either (1) a leakage current check or (2) a line to chassis resistance check. If the leakage current exceeds 0.5 milliamp, or if the resistance from chassis to either side of the power cord is less than 240 k ohms, the unit is defective.

WARNING — DO NOT return the unit to the customer until the problem is located and corrected.

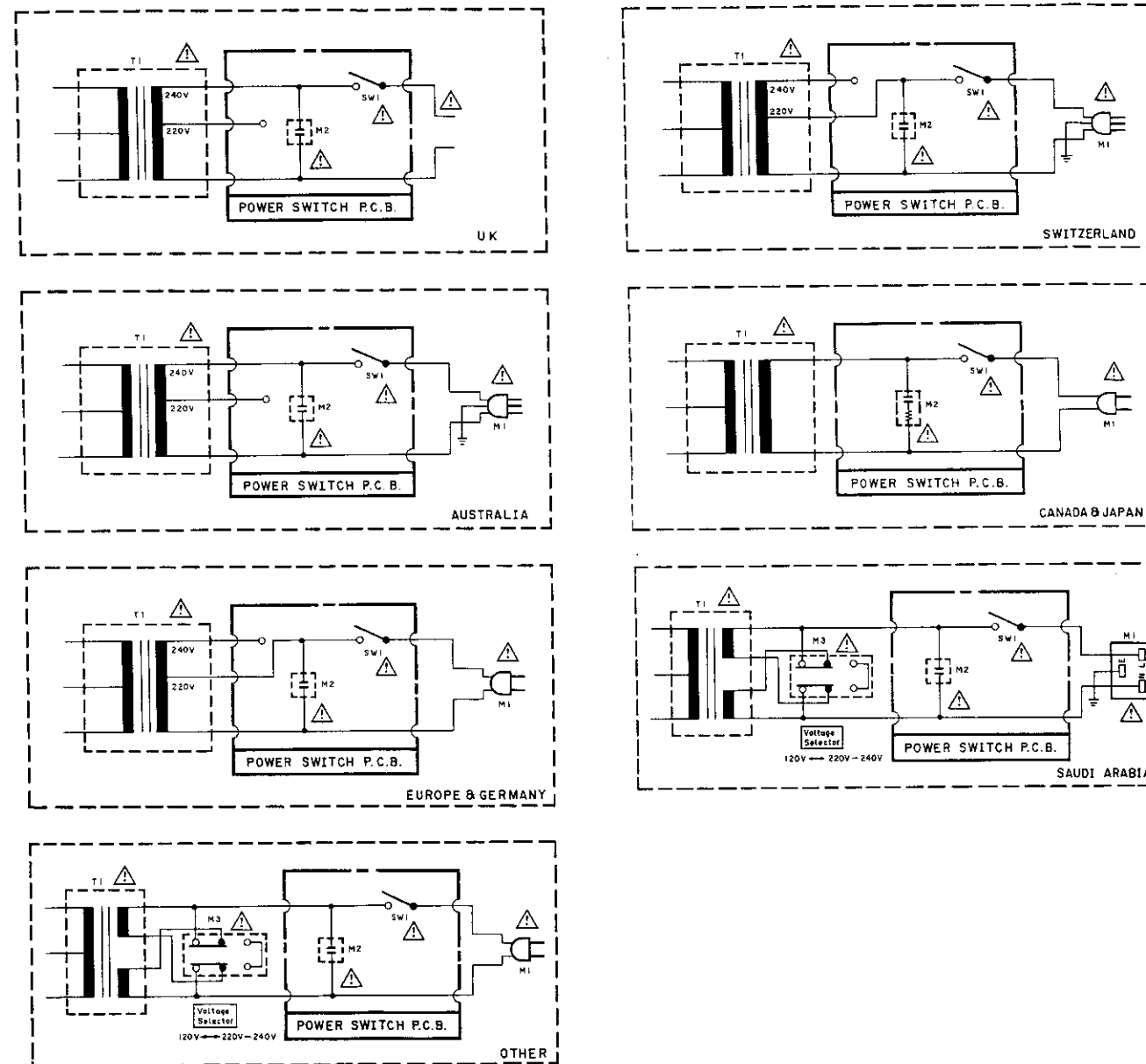
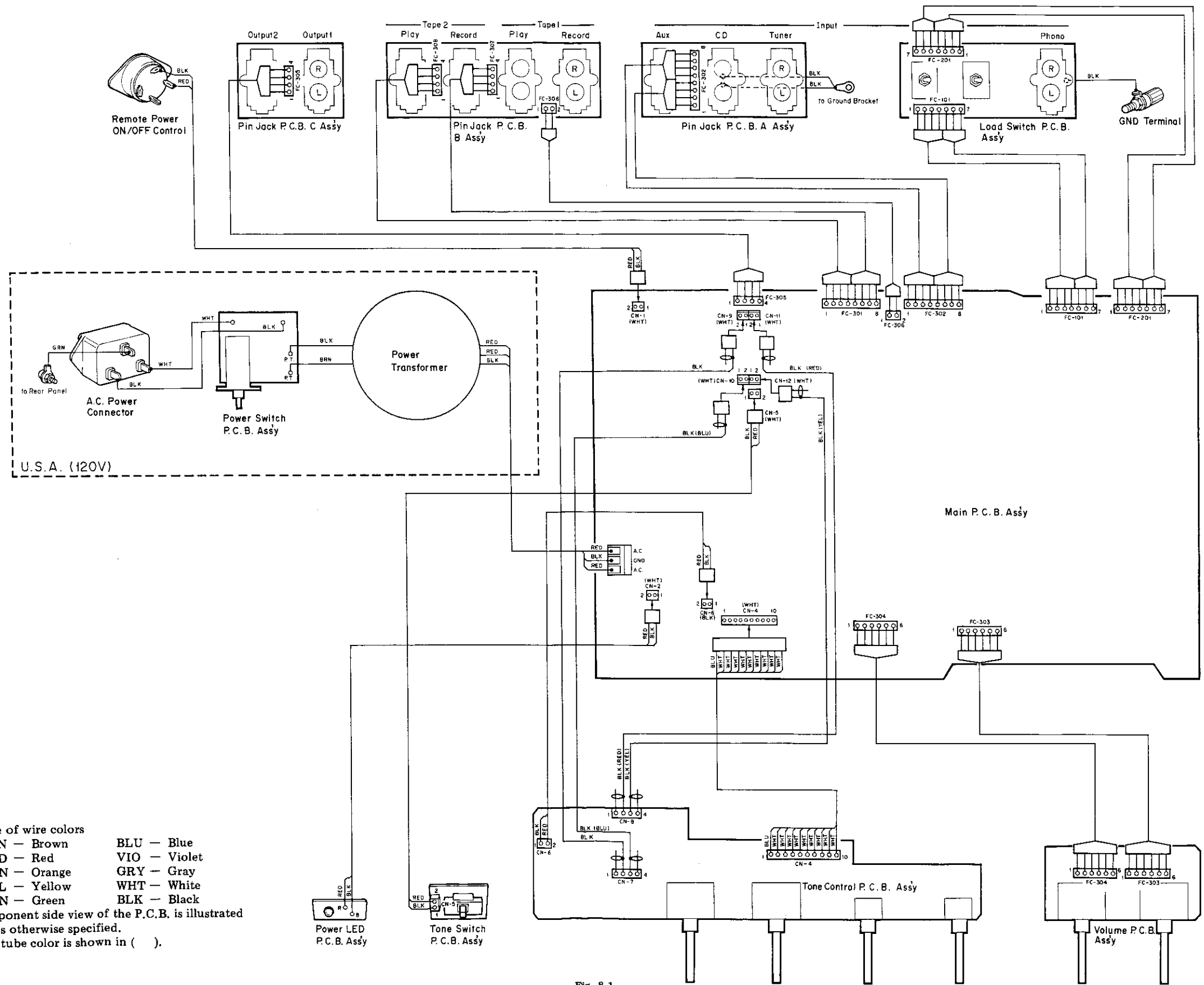

Fig. 7.2

8. WIRING DIAGRAM



- Notes: 1. Table of wire colors
 BRN — Brown BLU — Blue
 RED — Red VIO — Violet
 ORN — Orange GRY — Gray
 YEL — Yellow WHT — White
 GRN — Green BLK — Black
2. Component side view of the P.C.B. is illustrated unless otherwise specified.
3. Wire tube color is shown in ().

Fig. 8.1

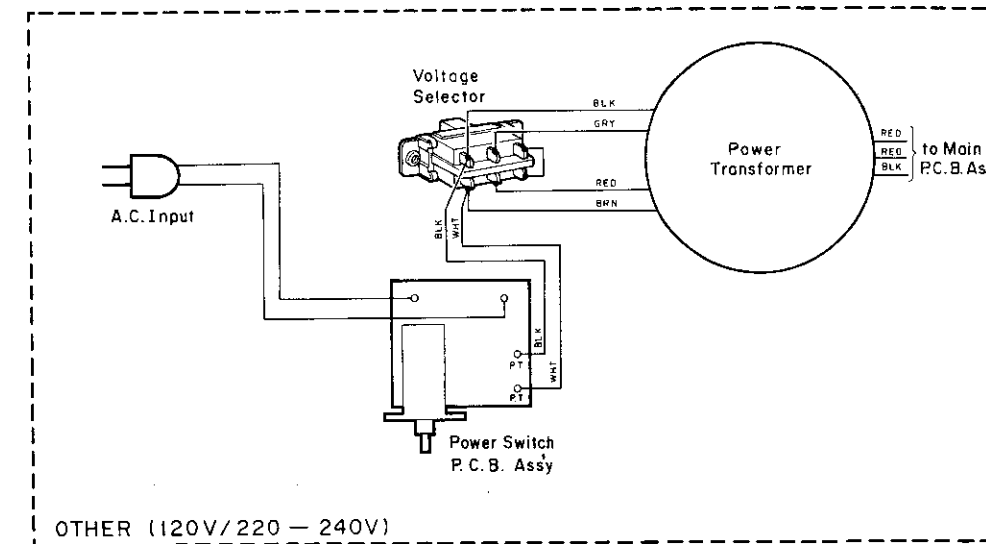
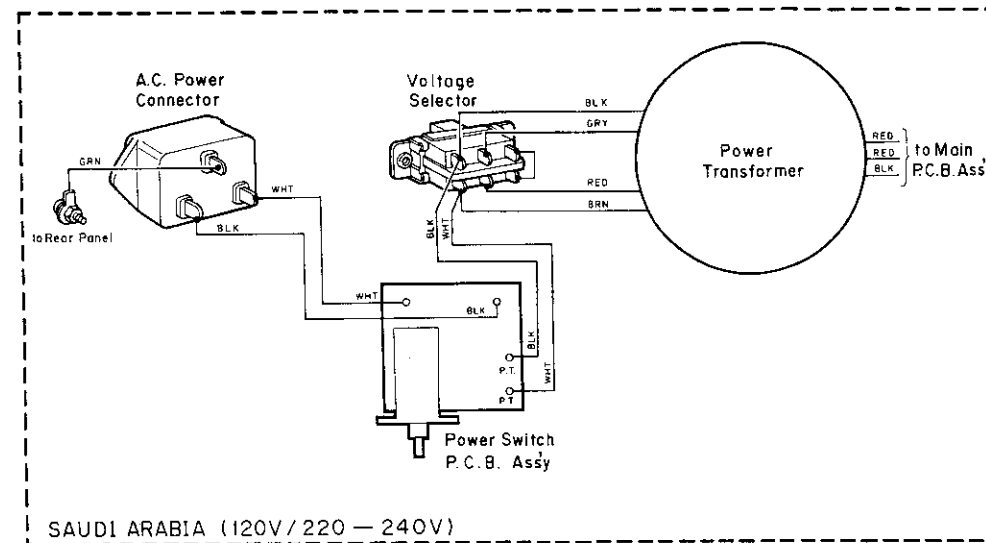
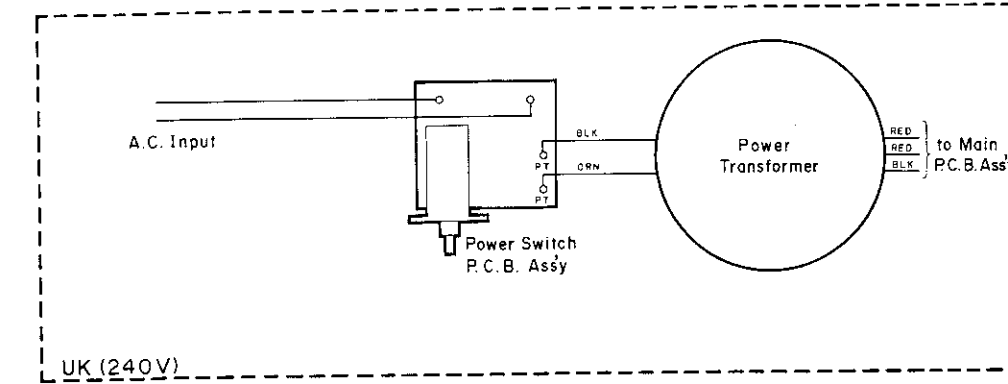
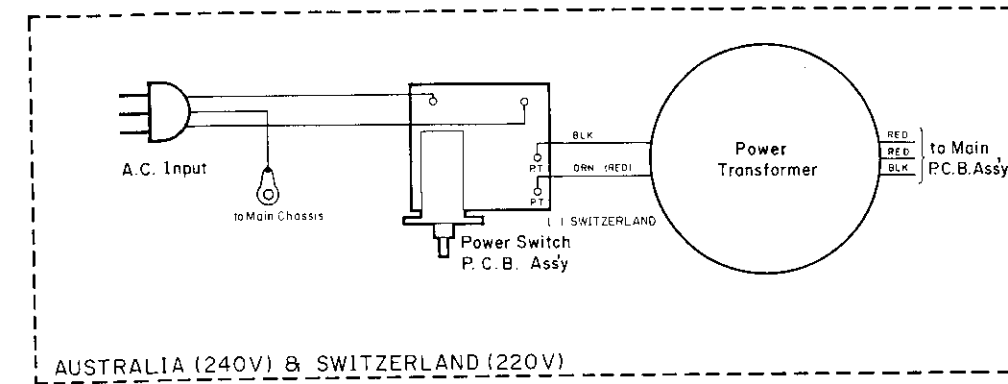
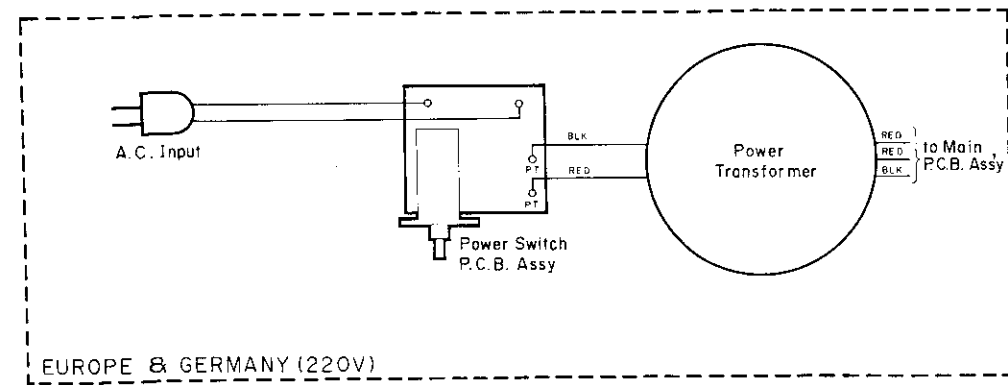
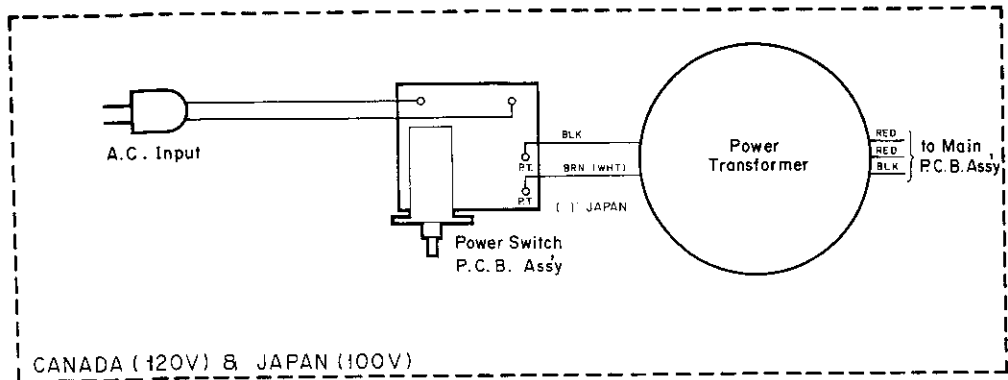

Fig. 8.2

9. BLOCK DIAGRAM

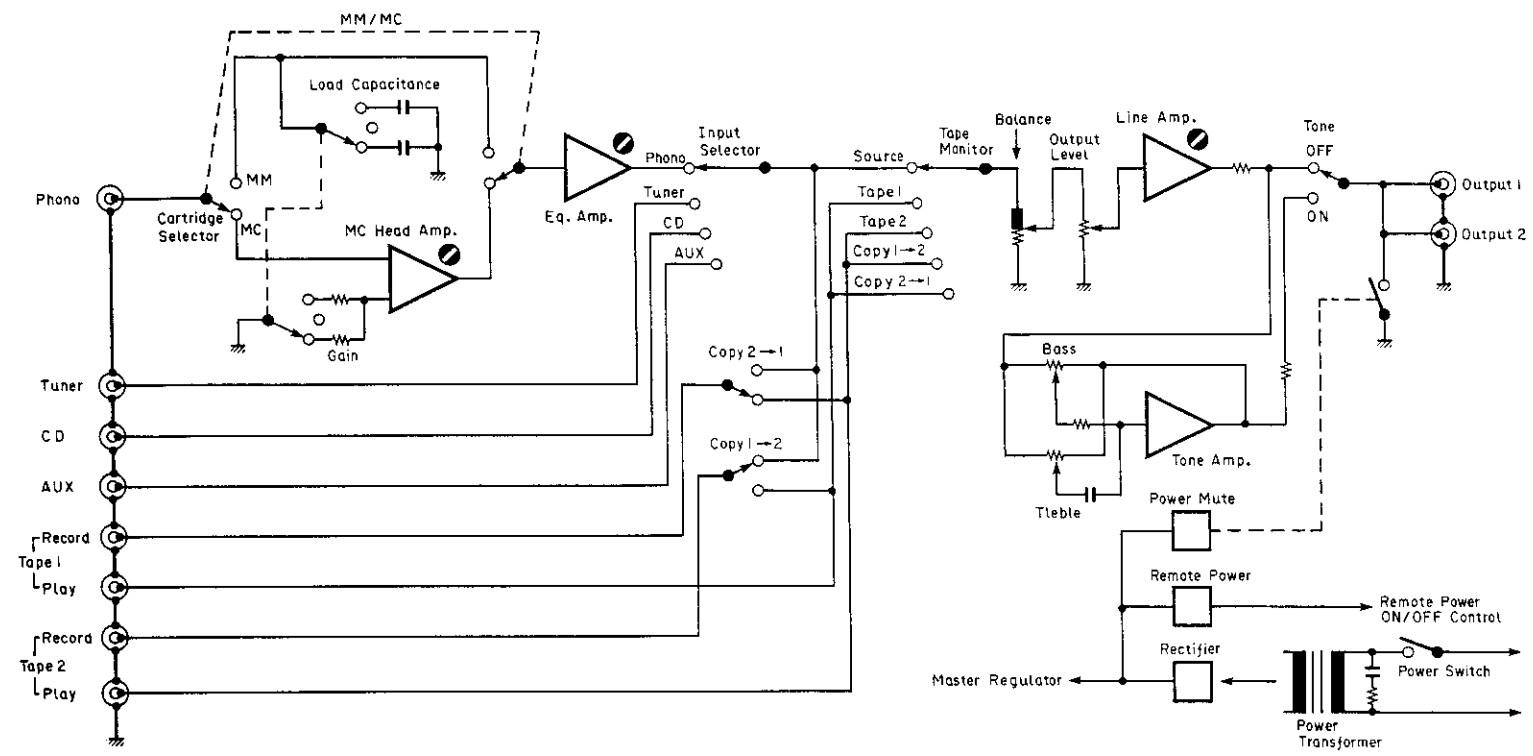

Fig. 9

10. SPECIFICATIONS

Input Sensitivity/Impedance	
Phono MC (36 dB Gain)	45 μ V/100 ohms
(30 dB Gain)	85 μ V/100 ohms
(24 dB Gain)	165 μ V/100 ohms
Phono MM	2.5 mV/50 kohms
Tuner/CD/Aux/Tape	150 mV/12.5 kohms
Input Sensitivity (New IHF)	
Phono MC (36 dB Gain)	11.3 μ V
(30 dB Gain)	21.3 μ V
(24 dB Gain)	41.3 μ V
Phono MM	0.63 mV
Tuner/CD/Aux/Tape	37.5 mV
Maximum Input Level (1 kHz, Non-Clipping Level, New IHF)	
Phono MC (36 dB Gain)	4.5 mV
(30 dB Gain)	8.5 mV
(24 dB Gain)	16.5 mV
Phono MM	270 mV
Output Level/Impedance	
Pre Out	2 V/1 kohms
Rec Out	150 mV/1 kohms
Maximum Output Level (20–20,000 Hz, 1% THD, Pre Out, New IHF)	
.	7 V
Total Harmonic Distortion (20–20,000 Hz)	
Phono MC to Rec Out, 1 V	
(36 dB Gain)	Less than 0.005%
(24 dB Gain)	Less than 0.004%
Phono MM to Rec Out, 1 V	Less than 0.002%
Tuner/CD/Aux/Tape to Pre Out, 2 V	
.	Less than 0.002%
Frequency Response	
Tuner/CD/Aux/Tape	1–100,000 Hz +0, –3 dB
.	1–20,000 Hz +0, –2 dB
RIAA Deviation	
Phono MC	20–20,000 Hz \pm 0.3 dB
Phono MM	20–20,000 Hz \pm 0.25 dB
Signal to Noise Ratio (IHF A-WTD)	
Phono MC (0.5 mV Input, 0.5 V Pre Out, Input Shorted)	
(36 dB Gain)	Better than 81 dB
(30 dB Gain)	Better than 80 dB
(24 dB Gain)	Better than 78 dB
Phono MM (5 mV Input, 0.5 V Pre Out, Input Shorted)	
.	Better than 88 dB
Tuner/CD/Aux/Tape (0.5 V Input, 0.5 V Pre Out, Input Shorted)	
.	Better than 95 dB
Stereo Separation (100 Hz/1 kHz/10 kHz)	
Phono MC (0.5 mV Input, 1 V Pre Out, Input Shorted)	
(36 dB Gain)	93/85/65 dB
(24 dB Gain)	90/84/64 dB
Phono MM (5 mV Input, 1 V Pre Out, Input Shorted)	
.	100/84/64 dB
Tuner/CD/Aux/Tape (0.5 V Input, 1 V Pre Out, Input Shorted)	
.	110/95/75 dB
Tone Control Characteristics	
Bass	20 Hz \pm 10 dB
Treble	20 kHz \pm 10 dB
Remote Power On/Off Control Output	
.	24 V DC
Power Source	120, 120/220–240, 220 or 240 V AC;
.	50/60 Hz (According to country of sale)
Power Consumption	23 W max.
Dimensions	435 (W) x 63 (H) x 287 (D) mm
.	17-1/8 (W) x 2-1/2 (H) x 11-5/16 (D) inches
Approximate Weight	5.1 kg, 11 lbs. 4oz.

- Specifications and design are subject to change for further improvement without notice.

Service Manual

Nakamichi

CA-5_{II}, CA-5A_{II}, CA-5E_{II}, CA-50_{II}

Nakamichi Corporation/Tokyo Office
Nakamichi America Corporation
Nakamichi Canada
Nakamichi GmbH

Shinjuku Daiichi Seimei Bldg., 2-7-1 Nishishinjuku, Shinjuku-ku, Tokyo 163 Phone: (03) 342-4461 Telex: 2324721 (NAKAM J)
19701 South Vermont Ave., Torrance, CA 90502 Phone: (213) 538-8150
276 South West, Marine Drive, Vancouver, B.C. V5X 2R4 Phone: (604) 324-7535
Stephanienstrasse 6, 4000 Düsseldorf 1 Phone: (0211) 359036

CA-5EII/CA-5AII/CA-5II Load Impedance Alteration Abschlußimpedanz-Anpassung des CA-5EII/CA-5AII/CA-5II Modification de l'impédance de charge du CA-5EII/CA-5AII/CA-5II

- For Dealers Only
- Nur für Händler
- Pour les distributeurs uniquement

The plastic bags contain five resistors each for the left and right channels. The load impedance when an MC-type cartridge is used can be altered by installing these resistors on the printed circuit boards in the CA-5EII/CA-5AII/CA-5II. (The load impedance is factory-set to 100 ohms.)

When wishing to make this alteration, contact your dealer. Never attempt to install the resistors yourself, as opening the unit involves a considerable risk of electric shock.

Die Plastiktüten enthalten je fünf Widerstände für rechten und linken Kanal. Bei Verwendung eines MC-Tonabnehmers kann die Lastimpedanz bei Bedarf durch Anbringen der Widerstände auf den Platinen des CA-5EII/CA-5AII/CA-5II verändert werden. (Die ab Werk eingestellte Impedanz beträgt 100 Ohm.) **Diese Anpassung darf nur durch autorisierte Händler durchgeführt werden, da bei Eingriffen in das Gerät Stromschlaggefahr besteht.**

Les sacs en plastique contiennent chacun cinq résistances pour les canaux gauche et droit. Lors de l'utilisation d'une tête de lecture à bobine mobile, l'impédance de charge peut être modifiée en installant ces résistances sur les circuits imprimés du CA-5EII/CA-5AII/CA-5II. (L'impédance de charge est réglée sur 100 ohms à la sortie de l'usine.)

Lorsque vous désirez effectuer cette modification, contactez votre distributeur. Ne jamais essayer d'installer les résistances par vous-même car l'ouverture de cet appareil peut entraîner de forts risques d'électrocution.

■ Procedure for installing resistors

Two resistors (one each for left and right channel) must be soldered to the circuit boards, as shown in the illustration. Be sure to turn the power OFF and unplug the power cord before opening the unit.

- Select the resistors for the desired load impedance according to their color codes, as indicated in the table on the reverse side.
- Trim the resistor leads as shown on the reverse side. Then insert the leads into the gold-plated sockets on the input section of the MC head amplifier board and solder each resistor solidly in place. Make sure that equal resistor values are used for the two channels.
- The resistors may be mounted in either direction.

■ Einbau

Zwei Widerstände (je einer für rechten und linken Kanal) müssen an den dafür vorgesehenen Stellen auf die Schaltplatinen gelötet werden, wie in der Abbildung gezeigt.

- Wählen Sie die zur Erzielung der gewünschten Abschlußimpedanz erforderlichen Widerstände nach ihrer Farbkodierung aus, wie in der umseitigen Tabelle aufgeführt.
- Kürzen Sie die Anschlußdrähte der Widerstände, wie umseitig gezeigt, und stecken Sie die Drähte in die vergoldeten Ösen auf der Platine (Eingangsstufe des MC-Vorverstärkers). Löten Sie dann die Drähte gut an. Achten Sie darauf, gleiche Widerstandswerte für beide Kanäle zu verwenden.
- Die Ausrichtung der Widerstände ist beliebig.

■ Pour l'installation des résistances

Les 2 résistances (une pour le canal gauche et une pour le canal droit) doivent être soudées sur les panneaux des enceintes. Vérifier que le courant n'est pas allumé et que la prise d'alimentation soit débranchée avant d'ouvrir le couvercle de l'appareil.

- Choisir les résistances suivant l'impédance de charge désirée en vous aidant des couleurs servant de repères, comme indiqué sur le tableau ci-après.
- Régler le bout des résistances comme indiqué au dos. Insérer ensuite les bouts dans les supports dorés dans la section d'entrée du pré-amplificateur et souder chaque résistance solidement à leur place. Vérifier que les résistances utilisées pour les deux courants soient de valeur égale.
- Les résistances peuvent être montées dans n'importe quel sens.

Desired load impedance Gewünschte Abschlußimpedanz Impédance de charge désirée	50 Ω	30 Ω	20 Ω	10 Ω	3 Ω
Resistor to install Einzulötender Widerstand Résistances à installer	100 Ω	42.2 Ω	26.1 Ω	11.5 Ω	3.16 Ω

How to read the color code

Farbkennzeichnung

Comment lire les couleurs servant de repères

Indicates the tolerance
Bezeichnet die Toleranz
Indique la tolérance

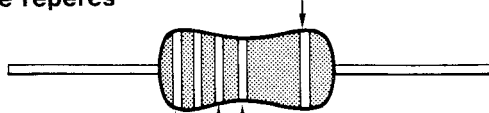

	1st stripe 1. Ring 1ère raie	2nd stripe 2. Ring 2ème raie	3rd stripe 3. Ring 3ème raie	4th stripe 4. Ring 4ème raie
100 Ω	Brown braun Marron	Black schwarz Noire	Brown braun Marron	—
42.2 Ω	Yellow gelb Jaune	Red rot Rouge	Red rot Rouge	Gold gold Dorée
26.1 Ω	Red rot Rouge	Blue blau Bleue	Brown braun Marron	Gold gold Dorée
11.5 Ω	Brown braun Marron	Brown braun Marron	Green grün Verte	Gold gold Dorée
3.16 Ω	Orange orange Orangée	Brown braun Marron	Blue blau Bleue	Silver silbern Argentée

Approx. 20 mm
ca. 20 mm
Approximativement 20 mm

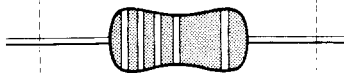

Trim the resistor leads.
Anschlußdrähte kürzen.
régler les bouts de résistance.

MC head amp input section Eingangsstufe des MC-Vorverstärkers section d'entrée de l'amplificateur MC

Solder solidly in place.
Gut einlöten.
solder solidement à leur place

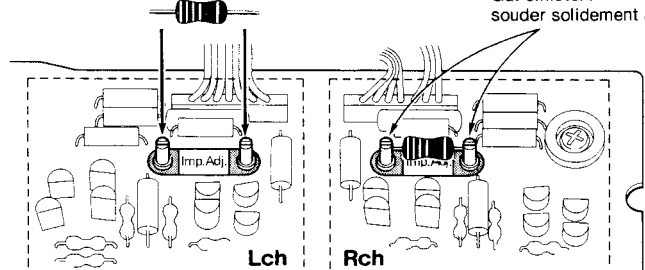

2

Be sure to unplug the power cord.
Unbedingt Netzstecker ziehen.
Bien s'assurer de débrancher le cordon d'alimentation.

1

Switch Power OFF.
Gerät ausschalten.
Mettre l'appareil hors tension.

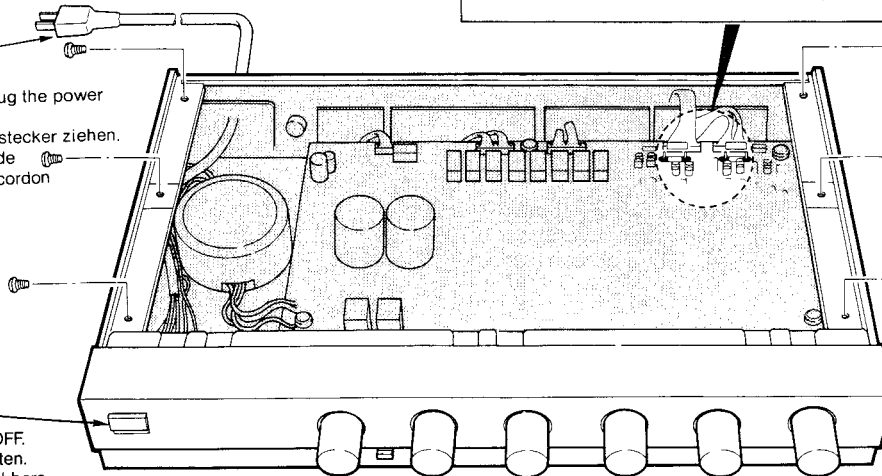

Hex wrench (2 mm)
Sechskantschlüssel (2 mm)
clé six pans de 2 mm

3

Remove six screws and take off the top cover.
Sechs Schrauben entfernen und obere Abdeckung abnehmen.
dévissier les 6 vis et soulever le couvercle