



Service Manual

Nakamichi

BX-100

BX-100E

2 Head Cassette Deck

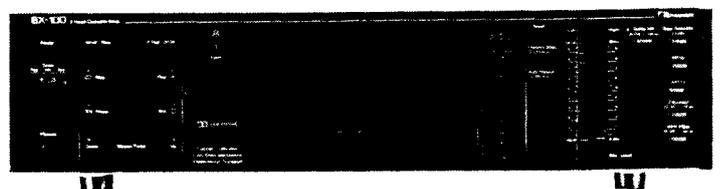

CONTENTS

1.	General	1
2.	Mechanical Adjustments	2
2. 1.	Tape Guide Height Check for Record/Playback Head and Erase Head	2
2. 2.	Head Base Stroke Check	2
2. 3.	Record/Playback Azimuth Alignment and Height Check	2
2. 4.	Pressure Adjustment of Pressure Roller	2
2. 5.	Tape Travelling Check	2
2. 6.	Eject Damper Adjustment	2
2. 7.	Reel Motor Speed Adjustment in Play Mode	3
2. 8.	Tape Speed Adjustment	3
2. 9.	Lubrication	3
3.	Parts Location for Electrical Adjustment	4
4.	Electrical Adjustments and Measurements	5
4. 1.	Adjustment and Measurement Instructions	5
4. 2.	Playback Frequency Response Adjustment	7
4. 3.	Dolby NR Circuit Check	8
5.	Mechanism Ass'y and Parts List	9
5. 1.	Synthesis	9
5. 2.	Synthesis Mechanism Ass'y (A01)	11
5. 3.	Mechanism Ass'y (B01)	13
5. 4.	Rear Panel Ass'y (B02)	13
6.	Mounting Diagrams and Parts List	15
6. 1.	Power Switch P.C.B. Ass'y	15
6. 2.	Shut-off P.C.B. Ass'y	15
6. 3.	Control Switch P.C.B. Ass'y	15
6. 4.	Timer Switch P.C.B. Ass'y	16
6. 5.	Volume P.C.B. Ass'y	16
6. 6.	Dolby NR P.C.B. Ass'y	16
6. 7.	Tape Switch P.C.B. Ass'y	16
6. 8.	Indicator P.C.B. Ass'y	16
6. 9.	Main P.C.B. Ass'y	18
7.	Schematic Diagrams	20
7. 1.	Attention to Servicemen	20
7. 2.	IC Block Diagrams	20
7. 3.	Schematic Diagrams	22
8.	Wiring Diagram	23
9.	Block Diagrams	24
10.	Timing Chart and Eq. Amp. Frequency Response	25
11.	Specifications	26

1. GENERAL

1.1. Voltage Selector

Voltage selector is installed on the rear panel for Other version of the Nakamichi BX-100. This voltage selector can select either 120 V or 220-240 V at customer's disposal.

1.2. Packing Materials and Owner's Manual

Part No.	Description	Q'ty
0F03736A	Carton Box BX-100 (Silver)	1
0F03750A	Carton Box BX-100E (Silver)	1
0F03737A	Carton Box BX-100 (Black)	1
0F03751A	Carton Box BX-100E (Black)	1
0F03674B	Packing	2
0D04311A	Owner's Manual (BX-100 (U.S.A., Canada & Australia) & BX-100E (UK))	1
0D04317A	Owner's Manual (BX-100 (Others) & BX-100E (220V Class 2))	1

1.3. Serial Number

The BX-100 has two versions, Silver and Black.

In the service manual, serial numbers of these versions are identified as follows:

Silver version: A318xxxxx
 Black version: A319xxxxx

However, the actual serial number on the serial number plate of the BX-100 is indicated as A318.9xxxxx. The serial number begins with A318.901001.

2. MECHANICAL ADJUSTMENTS

2.1. Tape Guide Height Check for Record/Playback Head and Erase Head

With use of an M-300 produced by Information Terminals, tape guide height check for the Record/Playback and Erase Heads shall be made, wherein a small block shall be pushed straight down to the base while in use of the M-300. Refer to Fig. 2.1.

- (1) **Record/Playback Head Tape Guide Height**
 - (a) Load the base of the M-300 carefully, then set the cassette deck in Play mode.
 - (b) Place the small block of the M-300 on the base.
 - (c) Slide the small block against the tape guide of the Record/Playback Head, and check to insure that the block is accepted by the tape guide.
 - (d) If not, loosen the screw and insert a shim (either 30 μm (OC80048A), 60 μm (OC80038A), or 100 μm (OC80039A)) to raise the Record/Playback Head, then tighten and apply a quantity of lock tight paint to the screw.
- (2) **Erase Head Tape Guide Height**
 - (a) Load the base of the M-300 carefully, then set the cassette deck in Play mode.
 - (b) Place the small block of the M-300 on the base.
 - (c) Slide the small block against the tape guide of the Erase Head, and check whether the block is accepted by the tape guide.

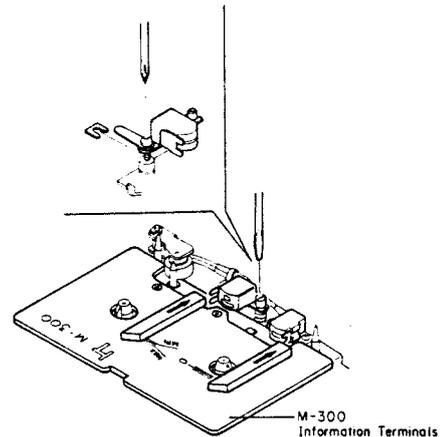

Fig. 2.1

2.2. Head Base Stroke Check

Refer to Fig. 2.2.

- (1) Load the base of the M-300 carefully, then push the base toward the Record/Playback Head to eliminate the clearance between the reference pin and the base.
- (2) Set the cassette deck in Play mode.
- (3) Place the small block of the M-300 on the base.
- (4) Contact the small block with the Record/Playback Head surface and the Erase Head surface, and check whether the end of the small block is located within the specified tolerance as shown in the figure.

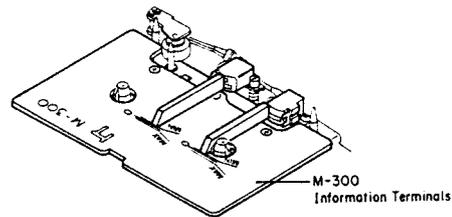

Fig. 2.2

2.3. Record/Playback Azimuth-Alignment and Height Check

Refer to Fig. 2.1.

- (1) Connect a VTVM to the Output Jacks.
- (2) Load a 15 kHz Azimuth Tape (DA09004B), then set the cassette deck in Play mode.
- (3) Turn the Azimuth Alignment Screw until the outputs of both channels become maximum.
- (4) Load a 1 kHz Track Alignment Tape (DA09007B), then set the cassette deck in Play mode.
- (5) Check to insure that the readings of both channels on the VTVM are below -25 dB.
If not, replacement of the Record/Playback Head will be required.
- (6) Apply a quantity of lock tight paint to the Azimuth Alignment Screw.

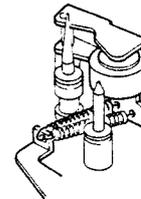

Fig. 2.3

2.4. Pressure Adjustment of Pressure Roller

Refer to Fig. 2.3.

- (1) In Play mode, measure the torque of the Pressure Roller and check whether the torque is in a range of 320 \pm 50 g-cm.
- (2) If torque is out of the range, correct it by changing the installation point of the Pressure Roller Spring.

2.5. Tape Travelling Check

Load the Tape Travelling Cassette (DA09027B), then set the cassette deck in Play mode and check the following:

- (1) After more than 2 seconds, the fluctuation of the tape travelling on the Record/Playback Head is small.
- (2) Tape is in contact with the head sufficiently.
- (3) Tape waving is small on the heads and pressure roller.

2.6. Eject Damper Adjustment

Refer to Fig. 2.4. Load a cassette tape, and with opening the Cassette Case by pressing the Eject button and closing it by hand, adjust the speed of damper movement by the Adjustment Screw.

CCW: Damper moves fast.

CW: Damper moves slowly.

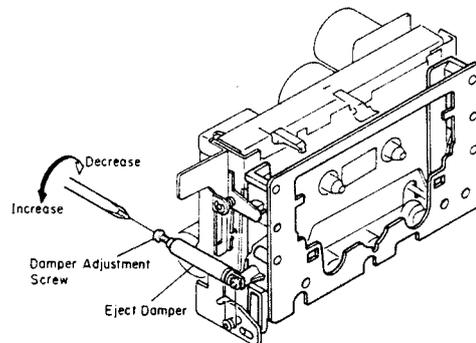

Fig. 2.4

2.7. Reel Motor Speed Adjustment in Play Mode

- (1) To warm-up the cassette deck, load a C-60 cassette tape and set the cassette deck in Play mode.
- (2) After more than four minutes, load a torque meter TW-211 (made by Sony) and set the cassette deck in Play mode.
- (3) Adjust VR601 on the Main P.C.B. Ass'y to obtain exactly 50 g-cm on the torque meter.

2.8. Tape Speed Adjustment

Refer to Fig. 2.5.

- (1) Connect a frequency counter to the Output Jacks.
- (2) Load a 3 kHz Speed and Wow/Flutter Tape (DA09006C) and play it back.
- (3) Adjust the Tape Speed Adjustment Volume incorporated in the Capstan Motor to obtain 3,000 Hz on the frequency counter.

CCW: Motor drives slowly.

CW: Motor drives fast.

2.9. Lubrication

The tape transport is of a lubrication-free type mechanism. When the following parts are replaced, apply the specified lubricant.

- (1) Molykote [®] Grease (X5-6020)
Cam Motor Pulley
Thrust portion on the Capstan Shaft
- (2) FLOIL GB-TS-1
Washer between Reel Hub Ass'y and Back Tension Spring
- (3) Diamond Oil (EP56)
Reel Hub Shaft
- (4) Anderol 456
Capstan Shaft

Note: We suggest that you use the above specified lubricant or equivalent type.

The company dealing in the above lubricant is as follows:

- (a) Molykote [®] Grease (X5-6020)
Dowcorning Co., Ltd., 1-15-1 Nishishinbashi, Minato-ku, Tokyo, Japan
- (b) FLOIL GB-TS-1
Kanto Chemicals Co., Ltd., 2-7 Kanda Sakuma-cho, Chiyoda-ku, Tokyo, Japan
- (c) Diamond Oil (EP-56)
Mitsubishi Oil Co., Ltd., 1-2-4 Toranomom, Minato-ku, Tokyo, Japan
- (d) Anderol 456
Toyo Kokusai Oil Co., Ltd., 3-3-5 Hatchobori, Chuo-ku, Tokyo, Japan

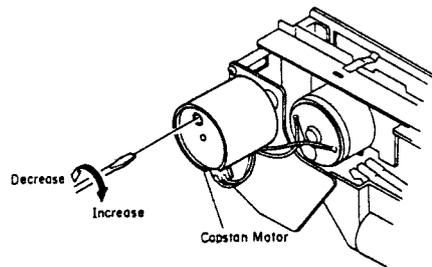

Fig. 2.5

3. PARTS LOCATION FOR ELECTRICAL ADJUSTMENT

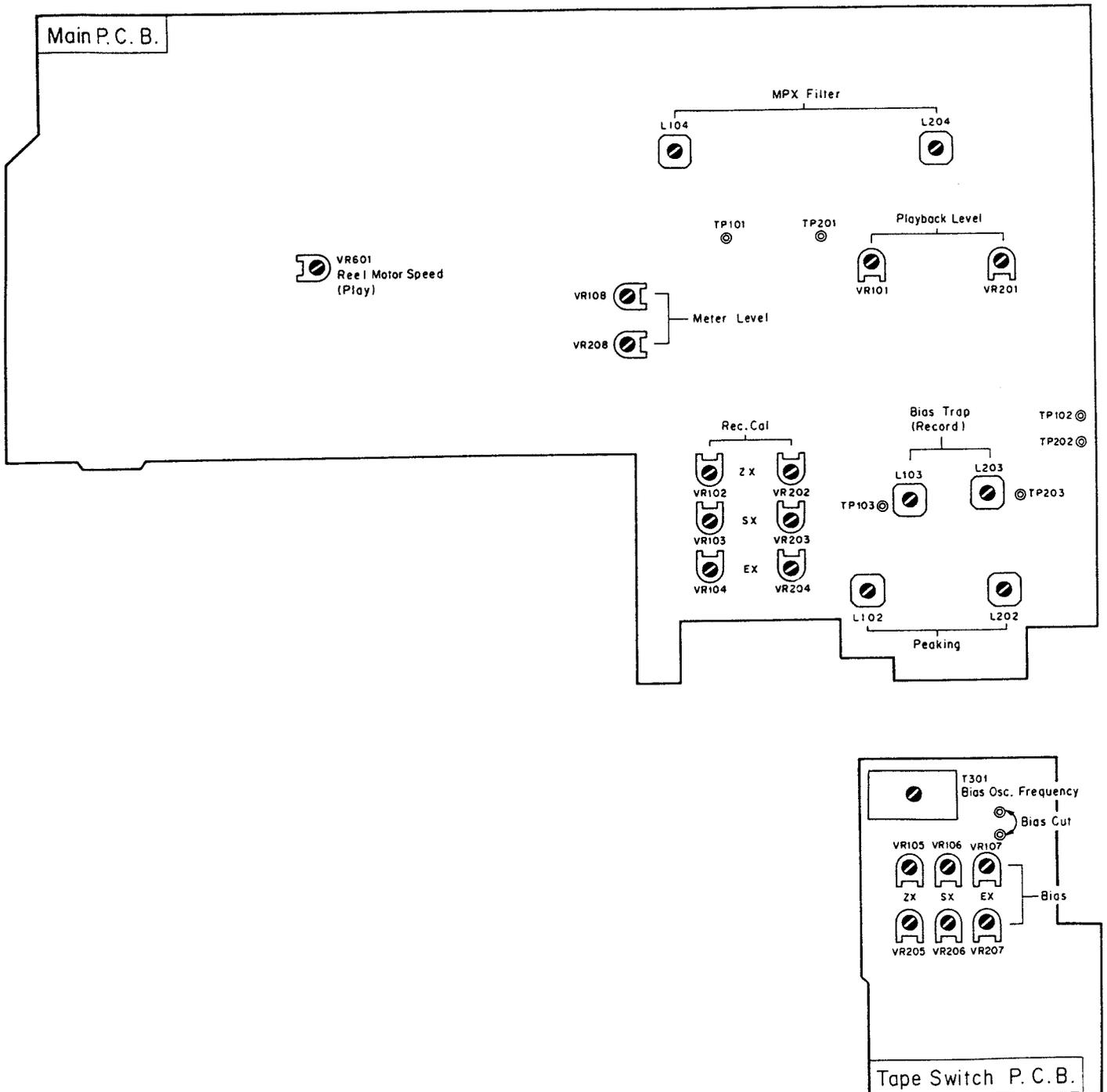

Fig. 3

4. ELECTRICAL ADJUSTMENTS AND MEASUREMENTS

Note: Electrical adjustment should be performed after mechanical adjustment is completed.
 4.1. Adjustment and Measurement Instructions

STEP	ITEM	SIGNAL SOURCE	OUTPUT CONNECTION	MODE	ADJUSTMENT	REMARKS
1	Tape Speed Adjustment	3 kHz Speed and Wow/Flutter Tape (DA09006C)	Frequency Counter to Output Jacks	Playback Eq. SW — 70 μ s	Tape Speed Adjustment Volume	Adjust the volume incorporated in the capstan motor to obtain 3 kHz \pm 0.5% on the frequency counter.
2	Meter Level Calibration	400 Hz to Input Jacks	VTVM to TP101, TP201 on Main P.C.B.	Record, Pause	Main P.C.B. VR108,VR208	<ol style="list-style-type: none"> 1. Feed in 400 Hz, then adjust the Input Level control to obtain 90 mV -0.8 dB on the VTVM. 2. Adjust VR108 (VR208) so that the 0 dB segment of the level meter starts illuminating. 3. Adjust the Input Level control to obtain 90 mV on the VTVM, then decrease the generator output level by 20 dB. 4. Check to insure that the segment for -20 dB illuminates.
3	MPX Filter Adjustment	400 Hz and 19 kHz \pm 100 Hz to Input Jacks	VTVM to Output Jacks	Record, Pause	Main P.C.B. L104,L204	<ol style="list-style-type: none"> 1. Feed in 400 Hz and adjust the Input Level control to obtain 0 dB (500 mV) on the VTVM. 2. Feed in 19 kHz, then adjust L104 (L204) to obtain minimum reading on the VTVM (minimum reading will be less than -30 dB).
4	Record/Playback Head Azimuth Alignment	15 kHz Azimuth Tape (DA09004B)	VTVM to Output Jacks	Playback Eq. SW — 70 μ s Dolby NR SW — OFF	Record/Playback Head Azimuth Alignment Screw	Adjust the Record/Playback Head Azimuth Alignment Screw to obtain maximum readings of both channels on the VTVM.
5	Playback Level Calibration	400 Hz Level Tape (DA09005B)	VTVM to TP101, TP201 on Main P.C.B.	Same as above	Main P.C.B. VR101,VR201	Adjust VR101 (VR201) to obtain 90 mV on the VTVM.
6	Playback Frequency Response Adjustment	400 Hz Level Tape (DA09005B) 10 kHz PB Frequency Response Tape (DA09003B) 15 kHz PB Frequency Response Tape (DA09002B) 20 kHz PB Frequency Response Tape (DA09001B)	VTVM to Output Jacks	Same as above	Main P.C.B. R110,R210 R195,R295	<ol style="list-style-type: none"> 1. Load a 400 Hz level tape and play it back. 2. Load 10 kHz, 15 kHz and 20 kHz PB frequency response tapes and adjust the record/playback head azimuth to obtain maximum levels on the VTVM with each tape. 3. Read the maximum levels with each tape and check to insure that the levels against the 400 Hz level tape are within the following ranges. If not, short R110 (R210) or R195 (R295) to obtain satisfactory results. 10 kHz (-20 dB) -2 dB to $+2$ dB 15 kHz (-20 dB) -2 dB to $+3$ dB 20 kHz (-20 dB) -2 dB to $+4$ dB Refer to the "Playback Frequency Response Adjustment" in item 4.2 for the detailed description. 4. Conduct step 4 "Record/Playback Head Azimuth Alignment".
7	Bias Oscillation Frequency and Erase Current Adjustment		Frequency Counter to TP102 on Main P.C.B. and VTVM across the additional 0.1 Ω resistor	Record, Pause Tape SW — ZX Eq. SW — 70 μ s Dolby NR SW — OFF	Main P.C.B. T301 R318,R350	<ol style="list-style-type: none"> 1. Adjust T301 to obtain 105 kHz on the frequency counter. 2. Connect an additional 0.1 Ω resistor in series to the Erase Head, then connect a VTVM across it. 3. Check the erase current by the VTVM. Erase current will be in a range of 145 mA to 185 mA (typically approx. 165 mA). If erase current is not sufficient, increase it by shorting R318 or R350. 4. After completion of the erase current adjustment, re-check the bias oscillation frequency. 5. Remove the additional 0.1 Ω resistor.
8	Record Amplifier Equalizer Adjustment	21 kHz (-20 dB) to Input Jacks	VTVM to TP102, TP202 on Main P.C.B.	Same as above	Main P.C.B. L102,L202	<ol style="list-style-type: none"> 1. Short both Bias Stop test pins with a clip to stop the bias oscillation. 2. Adjust L102 (L202) to obtain peak reading at 21 kHz on the VTVM. 3. Remove the clip from the test pins.
9	Bias Trap Adjustment (Record Amp.)	Remove input signals	VTVM to TP103, TP203 on Main P.C.B.	Same as above	Main P.C.B. L103,L203	Adjust L103 (L203) to obtain maximum reading on the VTVM.

STEP	ITEM	SIGNAL SOURCE	OUTPUT CONNECTION	MODE	ADJUSTMENT	REMARKS
10	Record Level Calibration and Recording Bias Current Adjustment	400 Hz (0 dB), 400 Hz (-20 dB), 10 kHz (-20 dB) and 17 kHz (-20 dB) to Input Jacks	VTVM to TP102, TP202 on Main P.C.B. and VTVM and Distortion Meter to Output Jacks	Record and Playback Tape SW — ZX/SX/EX Eq. SW — 70 μ s (ZX/SX) 120 μ s (EX) Dolby NR SW — OFF/ON	Main P.C.B. (Level) ZX: VR102, VR202 SX: VR103, VR203 EX: VR104, VR204 (Bias) ZX: VR105, VR205 SX: VR106, VR206 EX: VR107, VR207	Adjustment should be made in the order of ZX, SX and EX. 1. Set the Dolby NR switch to OFF. 2. Connect a VTVM to output Jacks. 3. Set the BX-100 in Record/Pause mode. 4. Feed in 400 Hz, then adjust the Input Level control to obtain 500 mV (0 dB) on the VTVM. 5. Load a reference ZX tape (DA09037A), reference SX tape (DA09025A) and reference EXII tape (DA09066A). 6. Adjust Record Cal. VR102 (VR202) for ZX, VR103 (VR203) for SX and VR104 (VR204) for EXII to center positions. 7. Connect the VTVM to TP102 (TP202) on the Main P.C.B. Ass'y. Adjust Bias VR105 (VR205) for ZX, VR106 (VR206) for SX and VR107 (VR207) for EXII to obtain the following bias current in Record/Pause mode (the VTVM is connected across a 10-ohm resistor). ZX: approx. 1 mA SX: approx. 0.5 mA EXII: approx. 0.3 mA 8. Connect the VTVM to the Output Jacks. 9. Feed in 400 Hz (-20 dB) and 17 kHz (-20 dB), then record, rewind and play them back. Adjust Bias VR105 (VR205) for ZX, VR106 (VR206) for SX and VR107 (VR207) for EXII to obtain the same playback levels at 400 Hz (-20 dB) and 17 kHz (-20 dB) on the VTVM. 10. Feed in 400 Hz (0 dB), then record, rewind and play it back. Adjust Record Cal. VR102 (VR202) for ZX, VR103 (VR203) for SX and VR104 (VR204) for EXII to obtain 0 dB on the VTVM. 11. Repeat above 9 and 10 two or three times to obtain optimum performance. 12. Set the Dolby NR switch to ON. 13. Feed in 400 Hz (-20 dB), 10 kHz (-20 dB) and 17 kHz (-20 dB), then record, rewind and play them back. Check to insure that the playback levels are within ± 2 dB against the levels in Dolby NR OFF. 14. Check to insure whether the total harmonic distortion is less than 1.0% for ZX and EXII tapes and 1.2% for SX tape. 15. If above is not sufficient, repeat 9 to 14 till satisfactory results are obtained.
11	Overall Frequency Response Adjustment	400 Hz (0 dB) and 20 Hz to 17 kHz (-20 dB) to Input Jacks	VTVM to Output Jacks	Record and Playback Tape SW — ZX/SX/EX Eq. SW — 70 μ s (ZX/SX) 120 μ s (EX) Dolby NR SW — OFF	Main P.C.B. L102, L202	1. Set the BX-100 in Record/Pause mode. 2. Feed in 400 Hz, then set the Input Level control to obtain 0 dB (500 mV) on the VTVM. 3. Decrease the generator output control by 20 dB. 4. Feed in 20 Hz to 17 kHz (-20 dB) and record, rewind and play them back, then check to insure whether the output levels are within -20 dB \pm 4 dB. 5. If above is not sufficient, adjust L102 (L202) to obtain approx. -20 dB on the VTVM, then conduct step 10 "Record Level Calibration and Recording Bias Current Adjustment". 6. If above is not sufficient, precise re-adjustment of step 6 "Playback Frequency Response", replacement of Record/Playback Head or check on item 2.5 "Tape Travelling Check" will be required.
12	Crosstalk Measurement	1 kHz to Input Jacks	1 kHz Band Pass Filter and VTVM to Output Jacks	Record and Playback Tape SW — ZX Eq. SW — 70 μ s Dolby NR SW — OFF		1. Erase the tape with bulk eraser. 2. Adjust the Input Level control to obtain 0 dB on the VTVM, and record the signals on the reference ZX tape (DA09037A). 3. Turn the cassette tape the other way round and play it back. 4. Measure the difference between 2 and 3.
13	Channel Separation Measurement	1 kHz to Input Jacks	Same as above	Same as above		1. Erase the tape with bulk eraser. 2. Adjust the Input Level control to obtain 0 dB on the VTVM, and set the Balance control to the extreme left (right). 3. Record, rewind and play it back, then measure the R ch (L ch) level.

STEP	ITEM	SIGNAL SOURCE	OUTPUT CONNECTION	MODE	ADJUSTMENT	REMARKS
14	Erasure Measurement	100 Hz to Input Jacks	100 Hz Band Pass Filter and VTVM to Output Jacks	Record and Playback Tape SW — ZX Eq. SW — 70 μ s Dolby NR SW — OFF		<ol style="list-style-type: none"> 1. Erase the tape with bulk eraser. 2. Adjust the Input Level control to obtain 0 dB on the VTVM, and record the signals on the reference ZX tape (DA09037A). 3. Rewind the tape, set the Input Level control to minimum, and then record again. 4. Rewind the tape, play it back, and then measure the difference between 2 and 3.
15	Signal to Noise Ratio Measurement	400 Hz to Input Jacks	IHF-A Curve, Filter, VTVM and Distortion Meter to Output Jacks	Record and Playback Tape SW — ZX Eq. SW — 70 μ s Dolby NR SW — ON		<ol style="list-style-type: none"> 1. Set the Dolby NR switch to ON. 2. Feed in 400 Hz, then record, rewind and play it back. 3. Adjust the Input Level control to obtain 3% total harmonic distortion in Playback mode. 4. Set the Input Level control to minimum then record again. 5. After rewind, play back and check the output level difference between 3 and 4. <p>Note: The filter of IHF-A curve shall be used in the measurements.</p>
16	Total Harmonic Distortion Measurement	400 Hz to Input Jacks	VTVM and Distortion Meter to Output Jacks	Record and Playback Tape SW — ZX/SX/EX Eq. SW — 70 μ s (ZX/SX) 120 μ s (EX) Dolby NR SW — OFF		<ol style="list-style-type: none"> 1. Adjust the Input Level control to obtain 0 dB on the VTVM. 2. Record, rewind and play it back. 3. Read the distortion meter and check to insure that the distortion is as follows: EXII 1.0% or less SX 1.2% or less ZX 1.0% or less
17	Wow/Flutter Measurement	3 kHz Speed and Wow/Flutter Tape (DA09006C)	Wow/Flutter Meter to Output Jacks	Playback Eq. SW — 70 μ s		Play back and read the wow/flutter meter.

4.2. Playback Frequency Response Adjustment

Figs. 4.1 and 4.2 show the playback amp. circuit for adjustment and the playback equalization curve.

This adjustment will be required if playback level is not sufficient during playing back a 20 kHz PB frequency response tape.

The peaking portion of the equalization curve compensates the gap loss of the playback head. Peaking level is varied by the short circuit of R110 (R210) or R195 (R295).

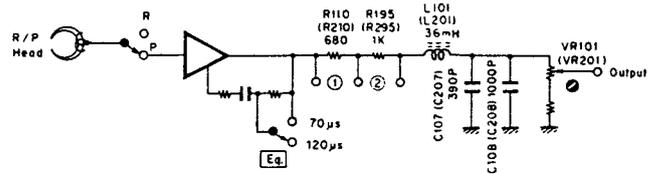

Fig. 4.1

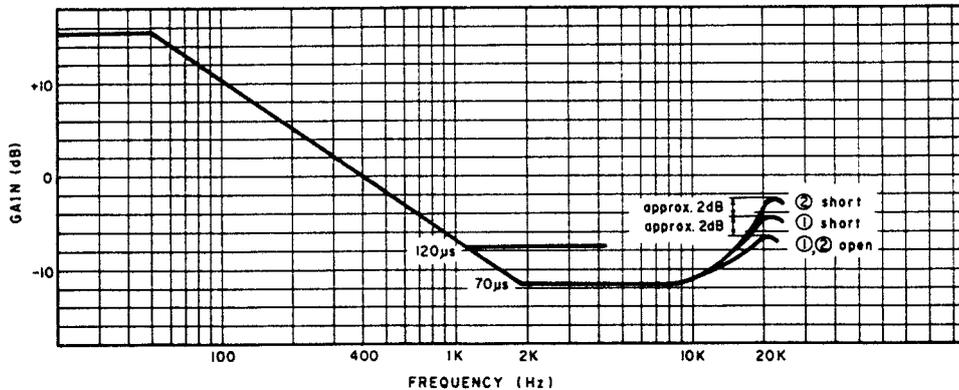

Fig. 4.2

4.3. Dolby NR Circuit Check

Dolby NR circuit incorporates a Dolby NR IC ($\mu A7300PC$) which has no adjustment point.

Perform the following checks and make sure that the IC operates accurately i.e., frequency response through IC is accurate.

Signal Source: 1.4 kHz to Input Jacks
Output Connection: VTVM to TP101 (TP201) and negative side of C141 (C241) on the Main P.C.B.
Mode: Record/Pause

- (1) Connect a VTVM to TP101 (TP201) on the Main P.C.B. Ass'y. Feed in 1.4 kHz and adjust the Input level control so that the VTVM may read 90 mV (0 dB) at each test point. Level meter will indicate 0 dB.
- (2) Remove the VTVM from TP101 (TP201) and reconnect it to the negative side of C141 (C241).
- (3) Decrease the input level (0 dB) by 20 dB or 30 dB. Check to insure that the level at negative side of C141 (C241) corresponds to the following with the Dolby NR switch ON and OFF.

Input Level at TP101 (TP201)	Level at negative side of C141 (C241)	
	Dolby NR OFF	Dolby NR B-Type
9 mV	0 dB	+3.2 dB \pm 1.5 dB
2.85 mV	0 dB	+8.2 dB \pm 1.5 dB

5. MECHANISM ASS'Y AND PARTS LIST

5.1. Synthesis

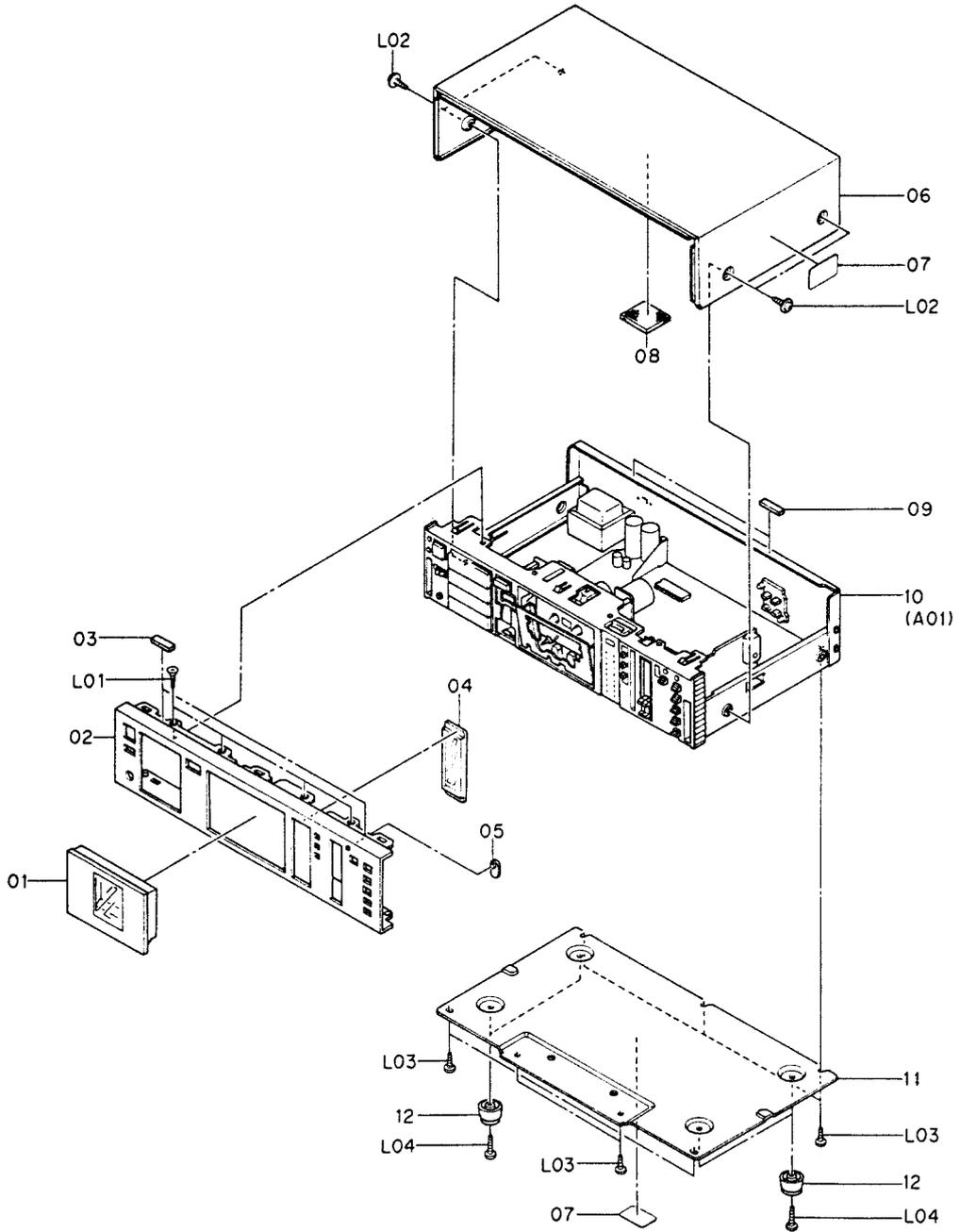

Fig. 5.1

Schematic Ref. No.	Part No.	Description	Q'ty	Schematic Ref. No.	Part No.	Description	Q'ty
		Synthesis Serial No.: A31801001 - (Silver)				Synthesis Serial No.: A31901001 - (Black)	
01	HA04494A	Cassette Case Cover Ass'y	1	01	HA04495A	Cassette Case Cover Ass'y	1
02	OH04263A	Front Panel BX-100	1	02	OH04264A	Front Panel BX-100	1
	OH04358A	Front Panel BX-100E	1		OH04359A	Front Panel BX-100E	1
03	OJ04628A	Top Cover Cushion (Front)	2	03	OJ04628A	Top Cover Cushion (Front)	2
04	OH04306A	Meter Cover	1	04	OH04306A	Meter Cover	1
05	OH04240A	Control Lens	1	05	OH04240A	Control Lens	1
06	OH04155B	Top Cover	1	06	OH04156B	Top Cover	1
07	OM04377A	Caution Label	1	07	OM04377A	Caution Label	1
08	OJ04630A	Top Cover Rubber	1	08	OJ04630A	Top Cover Rubber	1
09	OJ04629A	Top Cover Cushion (Rear)	1	09	OJ04629A	Top Cover Cushion (Rear)	1
10	—	Synthesis Mechanism Ass'y	1	10	—	Synthesis Mechanism Ass'y	1
11	OJ04762A	Bottom Cover	1	11	OJ04762A	Bottom Cover	1
12	OJ03564A	Leg T-H	4	12	OJ03564A	Leg T-H	4
L01	OE03054A	BT 3x8 @ Countersunk	4	L01	OE03054A	BT 3x8 @ Countersunk	4
L02	OE03033A	BT 4x8 @ Pan Washer-Faced	4	L02	OE03033A	BT 4x8 @ Pan Washer-Faced	4
L03	OE00868A	BT 3x8 @ Binding	7	L03	OE00868A	BT 3x8 @ Binding	7
L04	OE00865A	BT 3x10 @ Binding	4	L04	OE00865A	BT 3x10 @ Binding	4

5.2. Synthesis Mechanism Ass'y (A01)

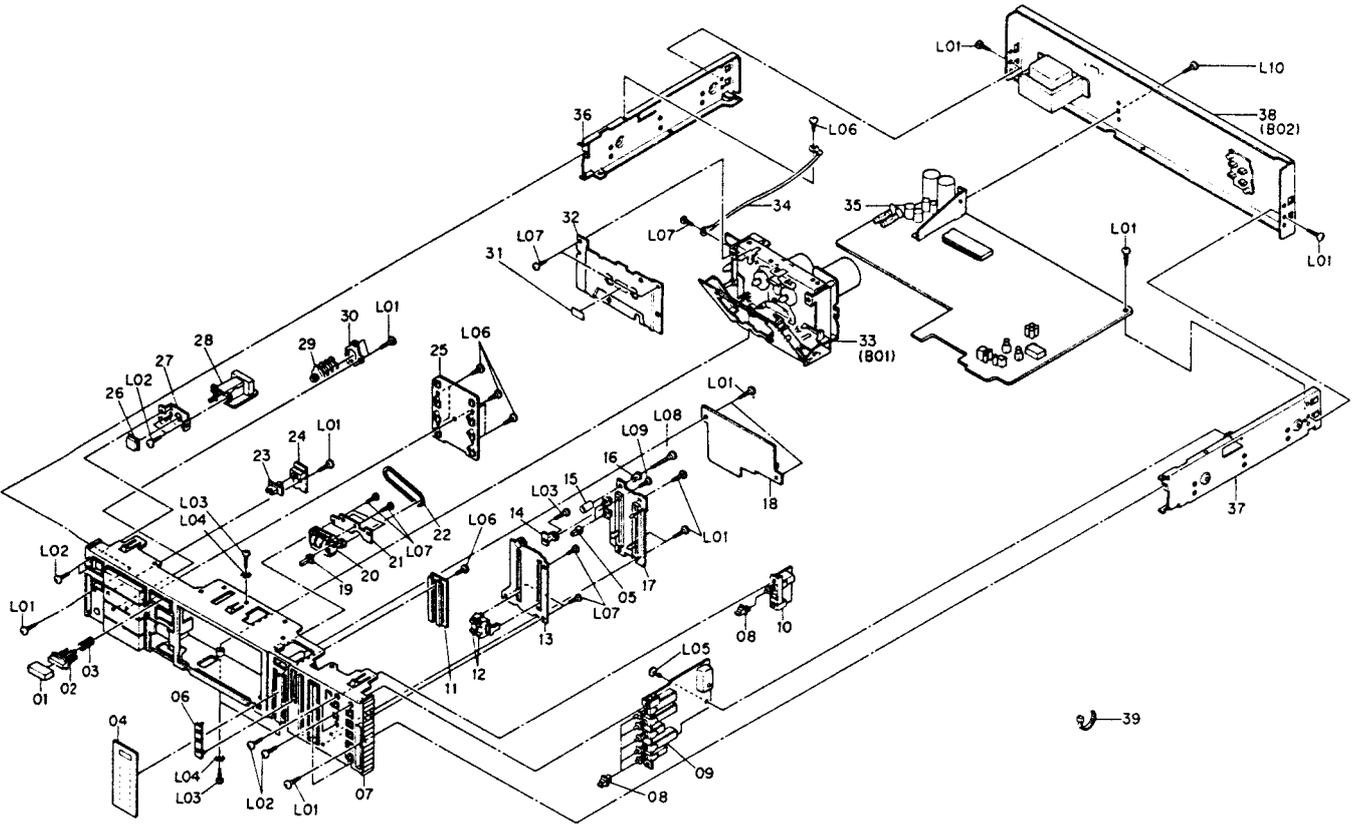

Fig. 5.2

Schematic Ref. No.	Part No.	Description	Qty	Schematic Ref. No.	Part No.	Description	Qty
A01		Synthesis Mechanism Ass'y Serial No.: A31801001 - (Silver)	1	A01		Synthesis Mechanism Ass'y Serial No.: A31901001 - (Black)	1
01	OH04270A	Eject Button	1	01	OH04269A	Eject Button	1
02	OJ04766A	Button Joint	1	02	OJ04766A	Button Joint	1
03	OJ04765A	Spring	1	03	OJ04765A	Spring	1
04	OH04277A	Meter Scale	1	04	OH04277A	Meter Scale	1
05	OH04272A	Memory Switch Knob	2	05	OH04271A	Memory Switch Knob	2
06	OH04276A	Counter Escutcheon	1	06	OH04275A	Counter Escutcheon	1
07	HA04522A	Front Chassis Sub Ass'y	1	07	HA04523A	Front Chassis Sub Ass'y	1
08	OH04288A	Push Switch Button	5	08	OH04248A	Push Switch Button	5
09	BA05073A	Tape Switch P.C.B. Ass'y	1	09	BA05073A	Tape Switch P.C.B. Ass'y	1
10	BA05076A	Dolby NR Switch P.C.B. Ass'y	1	10	BA05076A	Dolby NR Switch P.C.B. Ass'y	1
11	BA05089A	Indicator P.C.B. Ass'y	1	11	BA05089A	Indicator P.C.B. Ass'y	1
12	OH04289A	Volume Knob	2	12	OH04247A	Volume Knob	2
13	OH04283A	Volume Plate	1	13	OH04283A	Volume Plate	1
14	OJ04767A	Memory Switch Holder	1	14	OJ04767A	Memory Switch Holder	1
15	OJ04703A	P.C.B. Spacer A	1	15	OJ04703A	P.C.B. Spacer A	1
16	OJ04704A	P.C.B. Spacer B	1	16	OJ04704A	P.C.B. Spacer B	1
17	BA05075A	Volume P.C.B. Ass'y	1	17	BA05075A	Volume P.C.B. Ass'y	1
18	BA05074A	Indicator P.C.B. Ass'y	1	18	BA05074A	Indicator P.C.B. Ass'y	1
19	OH04274A	Counter Knob	1	19	OH04273A	Counter Knob	1
20	OC08602A	Tape Counter	1	20	OC08602A	Tape Counter	1
21	OJ04764A	Counter Holder	1	21	OJ04764A	Counter Holder	1
22	OC08604A	Counter Belt	1	22	OC08604A	Counter Belt	1
23	OH04309A	Slide Switch Knob	1	23	OH04242A	Slide Switch Knob	1
24	BA05078A	Timer Switch P.C.B. Ass'y	1	24	BA05078A	Timer Switch P.C.B. Ass'y	1
25	BA05077A	Control Switch P.C.B. Ass'y	1	25	BA05077A	Control Switch P.C.B. Ass'y	1
26	OH04290A	Power Switch Button	1	26	OH04243A	Power Switch Button	1
27	OJ04763A	Power Switch Holder	1	27	OJ04763A	Power Switch Holder	1
28	BA04823A	Power Switch P.C.B. Ass'y (BX-100 (U.S.A. & Canada))	1	28	BA04823A	Power Switch P.C.B. Ass'y (BX-100 (U.S.A. & Canada))	1
	BA04824A	Power Switch P.C.B. Ass'y (BX-100 (Australia & Others) & BX-100E)	1		BA04824A	Power Switch P.C.B. Ass'y (BX-100 (Australia & Others) & BX-100E)	1
29	OB08511A	Headphone Jack	1	29	OB08511A	Headphone Jack	1
30	OJ04611A	Headphone Plate	1	30	OJ04611A	Headphone Plate	1
31	OM04196A	Cassette Label	1	31	OM04196A	Cassette Label	1
32	OH04154B	Cover Plate	1	32	OH04154B	Cover Plate	1
33	CA08498A	Mechanism Ass'y	1	33	CA08498A	Mechanism Ass'y	1
34	BA05131A	Earth Wire	1	34	BA05131A	Earth Wire	1
35	BA05063A	Main P.C.B. Ass'y	1	35	BA05063A	Main P.C.B. Ass'y	1
36	OJ04603E	Side Chassis (L)	1	36	OJ04603E	Side Chassis (L)	1
37	OJ04773A	Side Chassis (R)	1	37	OJ04773A	Side Chassis (R)	1
38	HA04499A	Rear Panel Ass'y BX-100 (U.S.A. & Canada)	1	38	HA04505A	Rear Panel Ass'y BX-100 (U.S.A. & Canada)	1
	HA04502A	Rear Panel Ass'y BX-100 (Australia)	1		HA04508A	Rear Panel Ass'y BX-100 (Australia)	1
	HA04501A	Rear Panel Ass'y BX-100 (Others)	1		HA04507A	Rear Panel Ass'y BX-100 (Others)	1
	HA04498A	Rear Panel Ass'y BX-100E (UK)	1		HA04504A	Rear Panel Ass'y BX-100E (UK)	1
	HA04503A	Rear Panel Ass'y BX-100E (220V Class 2)	1		HA04509A	Rear Panel Ass'y BX-100E (220V Class 2)	1
39	OB08515A	Insu-lock	1	39	OB08515A	Insu-lock	1
--	OB82116B	Ribbon Cable 2P (160mm)	2	--	OB82116B	Ribbon Cable 2P (160mm)	2
--	OB82117B	Ribbon Cable 2P (220mm)	3	--	OB82117B	Ribbon Cable 2P (220mm)	3
--	OB82118B	Ribbon Cable 2P (300mm)	2	--	OB82118B	Ribbon Cable 2P (300mm)	2
--	OB82121B	Ribbon Cable 3P (330mm)	1	--	OB82121B	Ribbon Cable 3P (330mm)	1
--	OB82122B	Ribbon Cable 3P (360mm)	1	--	OB82122B	Ribbon Cable 3P (360mm)	1
--	OB82124B	Ribbon Cable 3P (410mm)	1	--	OB82124B	Ribbon Cable 3P (410mm)	1
--	OB82125B	Ribbon Cable 4P (300mm)	2	--	OB82125B	Ribbon Cable 4P (300mm)	2
--	OB82126B	Ribbon Cable 4P (360mm)	1	--	OB82126B	Ribbon Cable 4P (360mm)	1
--	OB82129B	Ribbon Cable 6P (280mm)	1	--	OB82129B	Ribbon Cable 6P (280mm)	1
--	OB82220A	Ribbon Cable 3P (160mm)	1	--	OB82220A	Ribbon Cable 3P (160mm)	1
--	OB82219A	P-D Connector Ass'y	1	--	OB82219A	P-D Connector Ass'y	1
L01	OE00868A	BT 3x8 @ Binding	15	L01	OE00868A	BT 3x8 @ Binding	15
L02	OE00766A	M3x8 @ Binding	6	L02	OE00766A	M3x8 @ Binding	6
L03	OE03074A	BT 2.6x8 @ Binding	3	L03	OE03074A	BT 2.6x8 @ Binding	3
L04	OE00233A	Washer 2.6mm Toothed Lock	2	L04	OE00233A	Washer 2.6mm Toothed Lock	2
L05	OB08583A	Plastic Rivet	1	L05	OB08583A	Plastic Rivet	1
L06	OE00857A	BT 3x6 @ Binding	7	L06	OE00857A	BT 3x6 @ Binding	7
L07	OE00859A	BT 2.6x6 @ Binding	10	L07	OE00859A	BT 2.6x6 @ Binding	10
L08	OE00835A	BT 3x25 @ Pan	1	L08	OE00835A	BT 3x25 @ Pan	1
L09	OE03070A	M2.6x6 @ Binding	1	L09	OE03070A	M2.6x6 @ Binding	1
L10	OE03028A	BT 3x8 @ Binding (Nickel)	1	L10	OE00921A	BT 3x8 @ Binding (Black Chromate)	1

5.3. Mechanism Ass'y (B01)

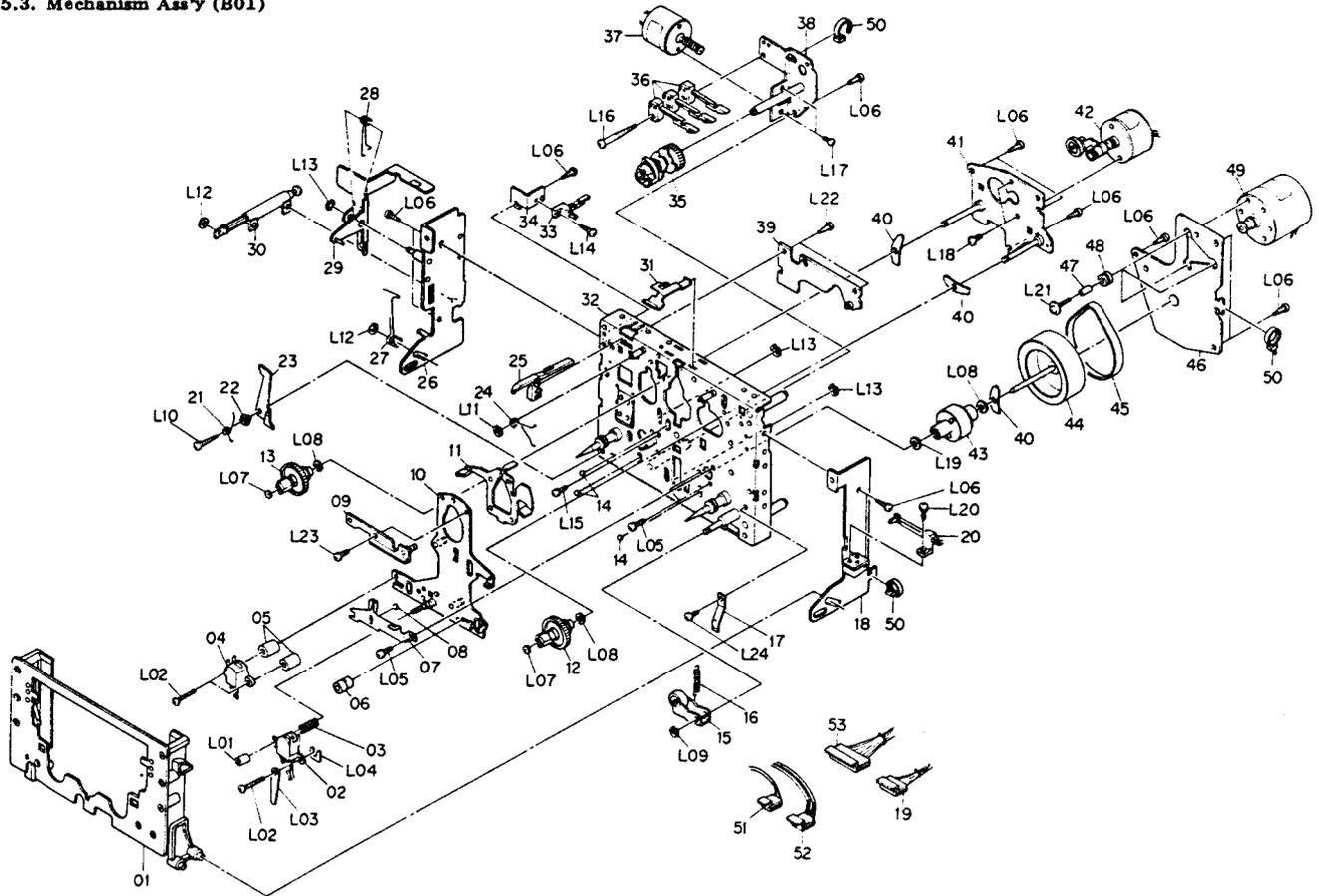

Fig. 5.3

5.4. Rear Panel Ass'y (B02)

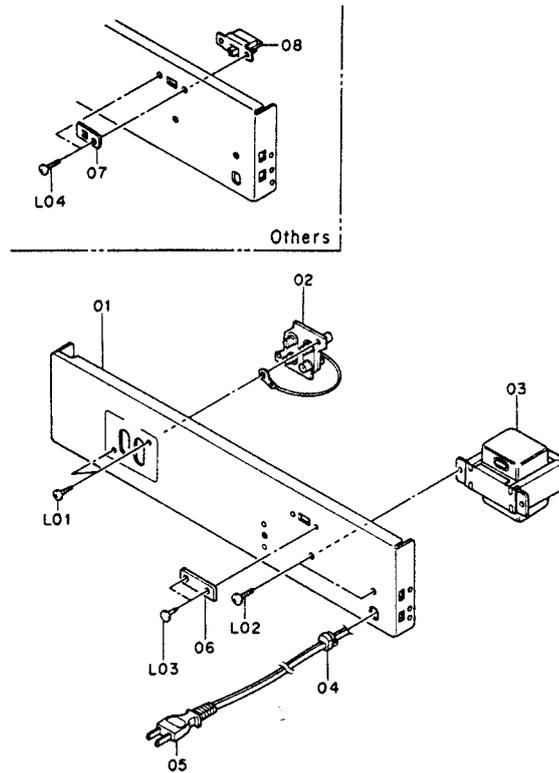

Fig. 5.4

Schematic Ref. No.	Part No.	Description	Qty	Schematic Ref. No.	Part No.	Description	Qty
B01	CA08498A	Mechanism Ass'y Serial No.: A318.901001 -	1	B02	HA04499A	Rear Panel Ass'y BX-100 (U.S.A. & Canada)	1
01	CA80001A	Cassette Case Ass'y	1		HA04501A	Rear Panel Ass'y BX-100 (Others)	1
02	0G01371A	Record/Playback Head RP-2G	1		HA04502A	Rear Panel Ass'y BX-100 (Australia)	1
03	0C80001A	Azimuth Adjust Spring	1		HA04498A	Rear Panel Ass'y BX-100E (UK)	1
04	0G01365A	Erase Head E-2D	1		HA04503A	Rear Panel Ass'y BX-100E (220V Class 2)	1
05	0C80044A	Erase Head Collar	2			Serial No.: A31801001 - (Silver)	
06	0C80045A	Record/Playback Head Collar	1	01	0H04298A	Rear Panel BX-100	1
07	0C80003A	Head Base Hold Plate	1		0H04362A	Rear Panel BX-100E	1
08	0C80004A	Steel Ball 30	1	02	0B81001A	4P Pin Jack	1
09	0C80005A	Reinforce Plate	1	03	0B50017A	Power Transformer (BX-100 (U.S.A. & Canada))	1
10	0C80006A	Head Base	1		0B50009A	Power Transformer (BX-100 (Australia) & BX-100E)	1
11	CA80002A	Brake Ass'y	1		0B50010B	Power Transformer (BX-100 (Others))	1
12	CA80003B	Take-up Reel Hub Ass'y	1	04	0B08037U	Cord Bushing 4P-4 (BX-100)	1
13	CA80004B	Supply Reel Hub Ass'y	1		0B08351A	Cord Bushing 4K-4 (BX-100E (UK))	1
14	0C80007A	Steel Ball 20	3	05	0B08533A	Power Cord (BX-100 (U.S.A., Canada & Others))	1
15	CA80005A	Pressure Roller Ass'y	1		0B08348A	Power Cord (BX-100E (UK))	1
16	0C80008A	Pressure Roller Spring	1		0B08093U	Power Cord (BX-100E (220V Class 2))	1
17	0C80009A	Cassette Case Spring	1	06	0B05241A	Power Cord (BX-100 (Australia))	1
18	0C80010B	Cassette Case Holder R	1		0J04622B	Switch Cover Gray (BX-100 (U.S.A., Canada & Australia) & (BX-100E))	1
19	0C80043A	5P-H Connector	1	07	0M04407A	Voltage Selector Lock Plate Gray (BX-100 (Others))	1
20	0C80012A	Eject Sensor	1	08	0B07092U	Voltage Selector (BX-100 (Others))	1
21	0C80013A	Lock Lever Spring	1	L01	0E03028A	BT 3x8 @ Binding (Nickel)	2
22	0C80014A	Lock Lever Collar	1	L02	0E03024A	BT 4x8 @ Binding	2
23	0C80015B	Lock Lever	1	L03	0B08583A	Plastic Rivet	2
24	0C80016A	Brake Spring	1	L04	0E03031A	M3x8 @ Binding (Nickel)	2
25	0C80017A	Record Protector Lever	1	B02	HA04505A	Rear Panel Ass'y BX-100 (U.S.A. & Canada)	1
26	0C80018A	Cassette Case Holder L	1		HA04507A	Rear Panel Ass'y BX-100 (Others)	1
27	0C80019B	Eject Spring	1		HA04508A	Rear Panel Ass'y BX-100 (Australia)	1
28	0C80020A	Eject Lever Spring	1		HA04504A	Rear Panel Ass'y BX-100E (UK))	1
29	0C80021A	Eject Lever	1		HA04509A	Rear Panel Ass'y BX-100E (220V Class 2)	1
30	CA80006A	Pneumatic Damper Ass'y	1			Serial No.: A31901001 - (Black)	
31	0C80022B	Cassette Hold Spring	1	01	0H04299A	Rear Panel BX-100	1
32	0C80023A	Mechanism Chassis	1		HA04363A	Rear Panel BX-100E	1
33	0C80024A	Record Protector	1	02	0B81001A	4P Pin Jack	1
34	0C80025A	Record Protector Holder	1	03	0B50017A	Power Transformer (BX-100 (U.S.A. & Canada))	1
35	0C80026A	Cam	1		0B50009A	Power Transformer (BX-100 (Australia) & BX-100E)	1
36	0C80027A	Mode Switch	3		0B50010B	Power Transformer (BX-100 (Others))	1
37	CA80007A	Control Motor Ass'y	1	04	0B08037U	Cord Bushing 4P-4 (BX-100 & BX-100E (220V Class))	1
38	0C80028A	Control Motor Holder	1		0B08351A	Cord Bushing 4K-4 (BX-100E (UK))	1
39	CA80011A	Shut-off P.C.B. Ass'y	1	05	0B08533A	Power Cord (BX-100 (U.S.A., Canada & Others))	1
40	0C80029A	Back Tension Spring	3		0B08348A	Power Cord (BX-100E (UK))	1
41	0C80030A	Reel Motor Holder	1		0B08093U	Power Cord (BX-100E (220V Class 2))	1
42	CA80008B	Reel Motor Ass'y	1	06	0B05241A	Power Cord (BX-100 (Australia))	1
43	0C80031A	Capstan Flange	1		0J04601B	Switch Cover Black (BX-100 (U.S.A., Canada & Australia) & BX-100E)	1
44	0C80033A	Flywheel	1	07	0J03948A	Voltage Selector Lock Plate Black (BX-100 (Others))	1
45	0C80034A	Capstan Belt	1	L01	0E00921A	BT 3x8 @ Binding (Black Chromate)	2
46	CA80009A	Flywheel Holder Ass'y	1	L02	0E00915A	BT 4x8 @ Binding (Black Chromate)	2
47	0C80035A	Sleeve	3	L03	0B08583A	Plastic Rivet	2
48	0C80036A	Floating Rubber	3	L04	0E00818A	M3x8 @ Binding (Black Chromate)	2
49	CA80010A	Capstan Motor Ass'y	1				
50	0C80037A	Insu-Lock	3				
51	0C80040A	2P-H Connector	1				
52	0C80041A	4P-H Connector	1				
53	0C80042A	9P-H Connector	1				
L01	0C80046A	Azimuth Adjust Screw	1				
L02	0E03038A	M2x12 @ Binding	3				
L03	0E03053A	Wire Holder	1				
L04	0C80048A	Shim 0.03T	(1)				
	0C80038A	Shim 0.06T	(1)				
	0C80039A	Shim 0.1T	(1)				
L05	0E03046A	M2.6x6 @ Pan (2A)	3				
L06	0E03042A	FT M2.5x5 @ Pan	12				
L07	0E03049A	Washer 1.8mm FT	2				
L08	0E03050A	Washer 3.1mm FT	3				
L09	0E00222A	E-Ring 2mm	1				
L10	0E03043A	FT M2.5x10 @ Pan	1				
L11	0E00698A	E-Ring 2.5mm	1				
L12	0E03052A	Stopper Ring 2.4mm	2				
L13	0E00181A	E-Ring 3mm	3				
L14	0E03048A	FT M2.6x6 @ Pan	1				
L15	0E03036A	M2x4 @ Pan (2A)	1				
L16	0E03044A	FT M2.5x20 @ Pan	1				
L17	0E00691A	M2x3 @ Pan	2				
L18	0E03045A	M2.6x3 @ Binding	2				
L19	0E03051A	Capstan Washer	1				
L20	0E03037A	M2x5 @ Pan (2A)	1				
L21	0E03047A	M2.6x9 @ Pan	3				
L22	0E03041A	FT M2.5x4 @ Pan	2				
L23	0E03040A	FT M2.5x3.5 @ Pan	1				
L24	0E03035A	M2x3.2 @ Truss	1				

6. MOUNTING DIAGRAMS AND PARTS LIST

Notes: 1. Mounting diagram shows a dip side view of the printed circuit board.

2. Diode is 1SS53, 1S1555, or 1SS176 unless otherwise specified.

3. Following transistors are interchangeable with each other.

a. 2SA733, 2SA608SP, 2SA1048, 2SA1175

b. 2SC945, 2SC536SP, 2SC2458, 2SC2785

4. Abbreviation for part name:

TR — Transistor, SiD — Silicon Diode, GD — Germanium Diode, ZD — Zener Diode

RK — Carbon Resistor, RM — Metal Film Resistor, RF — Fail Safe Type Resistor, RC — Cement Resistor,

RW — Wire Wound Resistor

CE — Electrolytic Capacitor, CM — Mylar Capacitor, CC — Ceramic Capacitor, CP — PP Capacitor,

CT — Tantalum Capacitor, CM — Film Capacitor, C — Mica Capacitor

6.1. Power Switch P.C.B. Ass'y

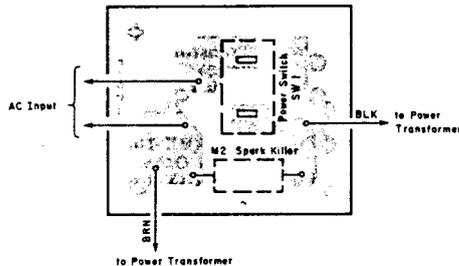

Fig. 6.1

6.2. Shut-off P.C.B. Ass'y

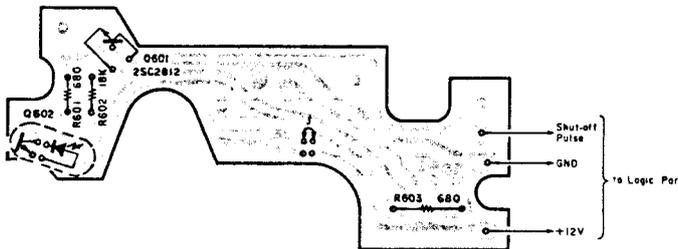

Fig. 6.2

6.3. Control Switch P.C.B. Ass'y

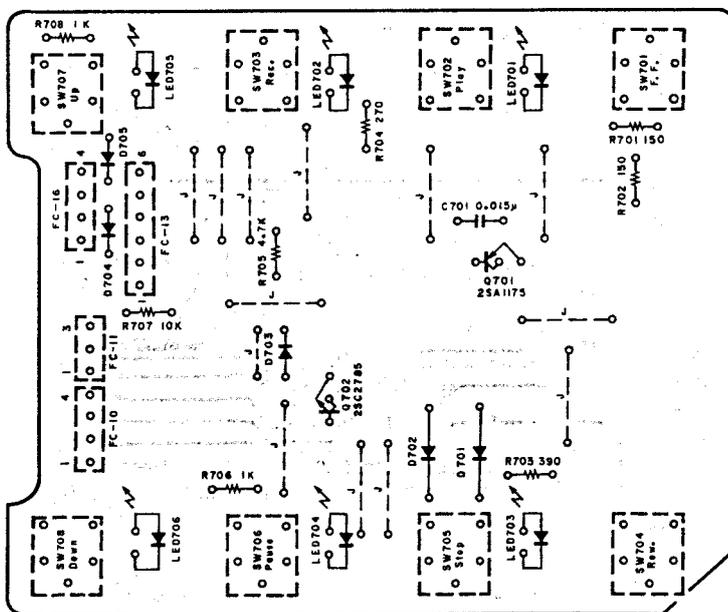

Fig. 6.3

Schematic Ref. No.	Part No.	Description
SW1 M2	BA04823A	Power Switch P.C.B. Ass'y (BX-100 (U.S.A. & Canada)
	BA04824A	Power Switch P.C.B. Ass'y (BX-100 (Australia & Others) & BX-100E)
	OB02573D	Power Switch P.C.B.
	OB70002A	Power Switch
	OB08342A	Spark Killer (BX-100 (U.S.A. & Canada))
	OB08955A	Spark Killer (BX-100 (Australia & Others) & BX-100E)
M2	OE00752A	Eyelet 2x3 (2)
	OB08359A	Spark Killer Cover (BX-100 (Australia & Others) & BX-100E)
	OJ04763A	Power Switch Holder (1)
	OE00612A	M3x6 ⊕ Pan (2A) (2)
Q601 Q602	CA80011A	Shut-off P.C.B. Ass'y
	OC80047A	Shut-off P.C.B.
	OB06388A	TR 2SC2812
	OB06389A	Photo Reflector NJL5141
	R601,603	RK 680 Leadless
	R602	OB09840A OB09841A RK 18K Leadless
Q701 Q702 LED701 703,704 LED702 705,706 D701,702 D703,704 705 R701,702 R703 R704 R705 R706,708 R707 C701 SW701-708	BA05077A	Control Switch P.C.B. Ass'y
	OB60036B	Control Switch P.C.B.
	OB06455A	TR 2SA1175
	OB06456A	TR 2SC2785
	OB06334A	LED TLG124A
	OB06333A	GRN LED TLR124A
	OB06181A	RED LED TLR124A
	OB06398A	SiD 1SS53 SiD 1SS176
	OB09657A	RK 150 1/6W J
	OB09667A	RK 390 1/6W J
	OB09663A	RK 270 1/6W J
OB09693A	RK 4.7K 1/6W J	
OB09677A	RK 1K 1/6W J	
OB09701A	RK 10K 1/6W J	
OB05557A	CM 0.015μ 50V J	
OB70004A	Touch Switch 4.3mm	
OJ04744A	LED Reflector (6)	
R709 SW601	BA05078A	Timer Switch P.C.B. Ass'y
	OB60037B	Timer Switch P.C.B.
	OB09687A	RK 2.7K 1/6W J
	OB07437A	Slide Switch 2-3 Dip Mate 4P (1)
OB81011A		

6.4. Timer Switch P.C.B. Ass'y

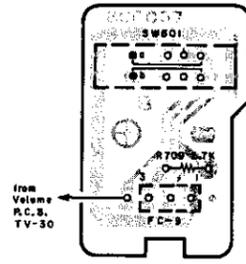

Fig. 6.4

6.5. Volume P.C.B. Ass'y

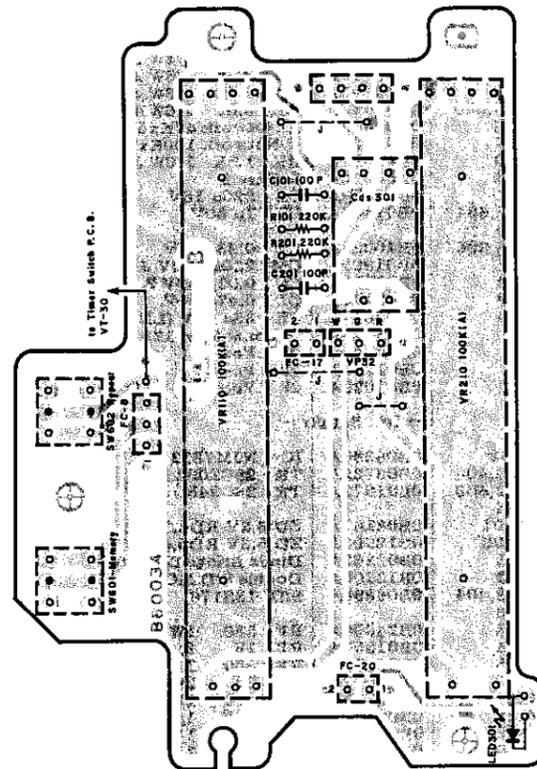

Fig. 6.5

6.8. Indicator P.C.B. Ass'y

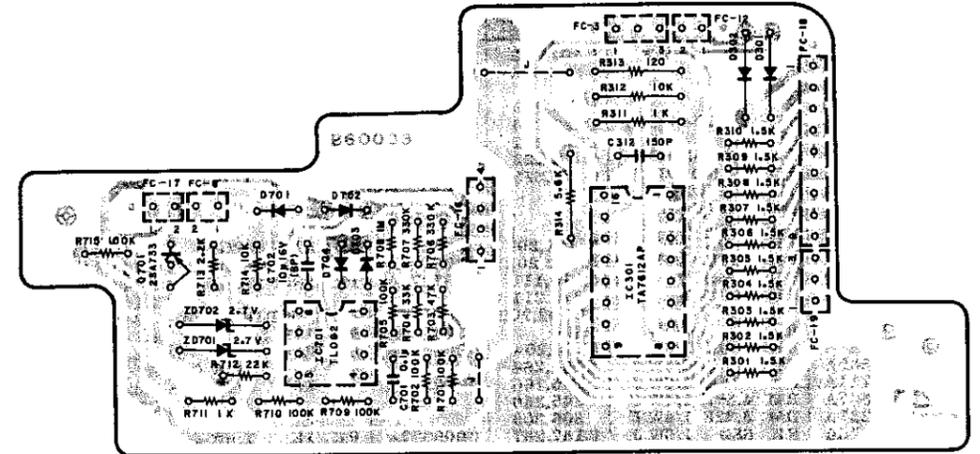

Fig. 6.8

6.6. Dolby NR P.C.B. Ass'y

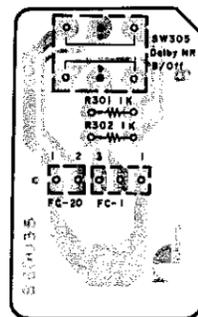

Fig. 6.6

6.7. Tape Switch P.C.B. Ass'y

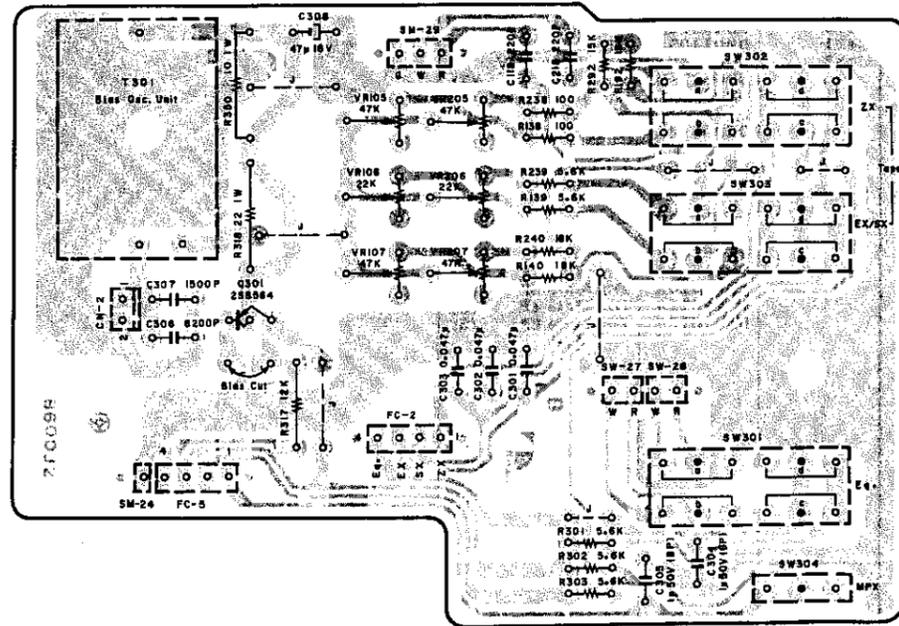

Fig. 6.7

Schematic Ref. No.	Part No.	Description	Schematic Ref. No.	Part No.	Description
	BA05075A	Volume P.C.B. Ass'y		BA05074A	Indicator P.C.B. Ass'y
VR110,210	OB60034B	Volume P.C.B. Slide Volume 100K (A)	IC301	OB60033B	Indicator P.C.B. IC TA7612AP
LED301	OB09733A	LED TLR124A RED	IC701	OB11031A	IC TL092
R101,201	OB09282A	RK 220K 1/6W J	Q701	OB06013A	TR 2SA733 (P,Q)
C101,201	OB07462A	CC 100P 50V K	ZD701,702	OB06191A	ZD 2.7V RD2.7E
SW601,602	OB06325B	Push Switch Photocoupler MCD7214F	D301,302	OB06181A	SID 1SS53
Cds301	OB81002A	Dip Mate 2P (1)	D701,702	OB06398A	SID 1SS176
	OB81011A	Dip Mate 4P (2)	703,704	OB09681A	RK 1.5K 1/6W J
	OB81012A	Dip Mate 5P (1)	R301-310	OB01857A	RK 1K 1/4W J
			R311	OB01888A	RK 10K 1/4W J
			R312	OB09797A	RK 120 1/4W J
			R313	OB01887A	RK 5.6K 1/4W J
			R314	OB09725A	RK 100K 1/6W J
			R701,702		
			705,709		
			710,715		
			R703	OB09717A	RK 47K 1/6W J
			R704	OB09713A	RK 33K 1/6W J
			R706,707	OB09737A	RK 330K 1/6W J
			R708	OB09749A	RK 1M 1/6W J
			R711	OB09677A	RK 1K 1/6W J
			R712	OB09709A	RK 22K 1/6W J
			R713	OB09685A	RK 2.2K 1/6W J
			R714	OB09701A	RK 10K 1/6W J
			C312	OB09281A	CC 150P 50V K
			C701	OB09868A	CF 0.1μ 50V (BP)
			C702	OB09163A	CE 10μ 16V (BP)
			FC18,19	OB02356A	JF Connector 12P
					(1)
Q301	OB60032B	Tape Switch P.C.B. TR 2SB564M		OB81011A	Dip Mate 4P (2)
T301	OB06688C	Bias Osc. Unit		OB81012A	Dip Mate 5P (1)
VR105,107	OB32010A	Semi-fixed VR 47K			
205,207					
VR106,206	OB32009A	Semi-fixed VR 22K			
R138,238	OB09653A	RK 100 1/6W J			
R139,239	OB09695A	RK 5.6K 1/6W J			
301,302					
303					
R140,240	OB09707A	RK 18K 1/6W J			
R192,292	OB09705A	RK 15K 1/6W J			
R317	OB09263A	RK 12K 1/4W J			
R318	OB09831A	RF 22 1W J			
R350	OB09837A	RF 10 1W J			
C118,218	OB09283A	CC 220P 50V K			
C301,302	OB05796A	CM 0.047μ 50V J			
303					
C304,305	OB09187A	CE 1μ 50V (BP)			
C306	OB09828A	CP 8200P 100V J			
C307	OB41229A	CP 1500P 100V J			
C308	OB01403A	CE 47μ 16V			
SW301-304	OB70005A	Push Switch (1)			
	OB81010A	Dip Mate 3P (1)			
	OB81011A	Dip Mate 4P (2)			
	OB81012A	Dip Mate 5P (1)			
	OB81051A	2P-S Post (1)			
	OJ04768A	Earth Plate A (1)			

6.9. Main P.C.B. Assy

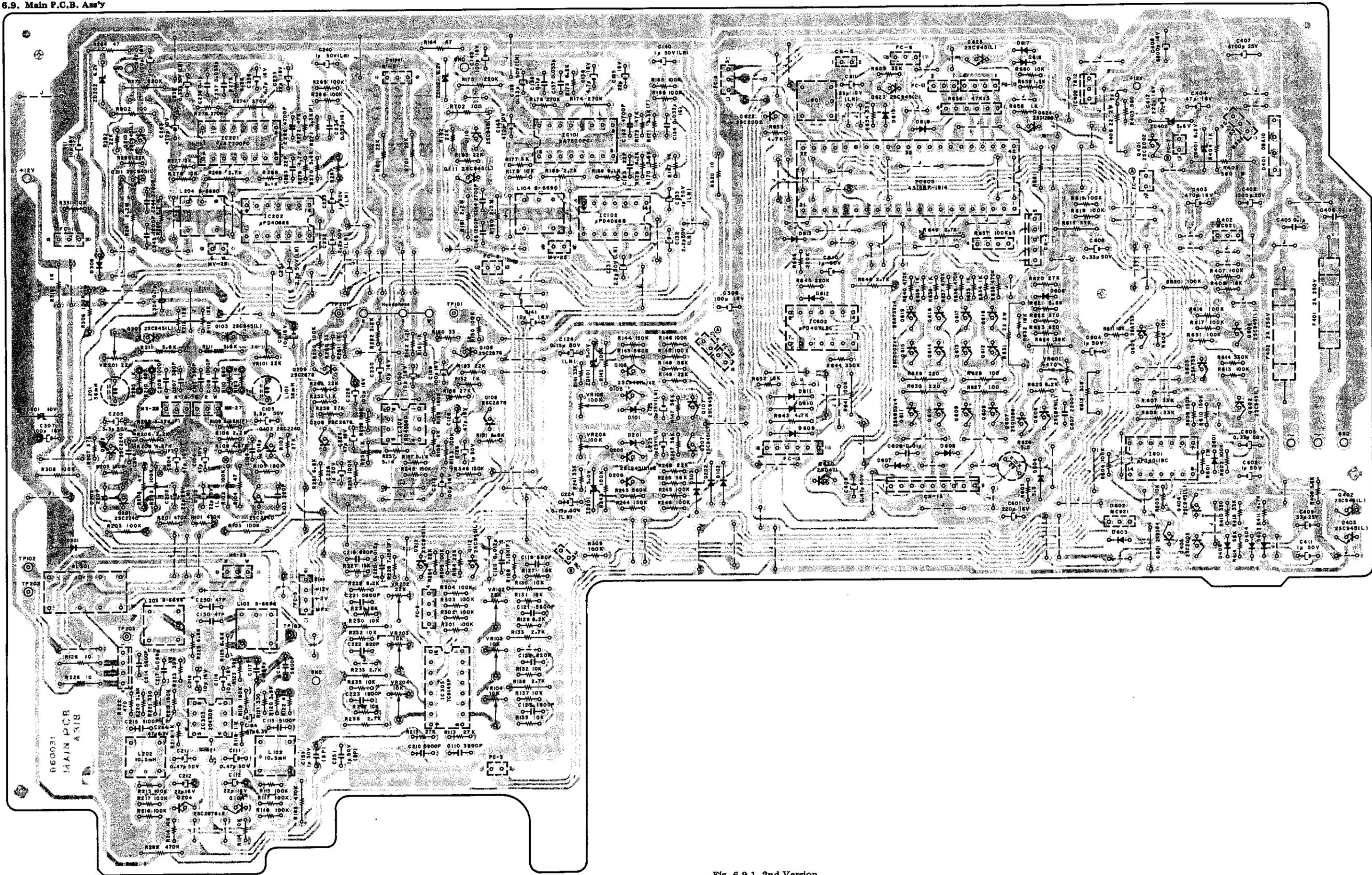

Fig. 6.9.1 2nd Version

7. SCHEMATIC DIAGRAMS

7.1. Attention to Servicemen

(1) Caution

- If a part is in need of removing (or replacing) for service, it should be remounted (or replaced with specified parts) by the same methods as before after servicing.
- The appliance should be used only specified parts for preventing a risk of fire and electric shock and maintaining the characteristics.
- Before returning the repaired appliance to a customer, check to insure that the exposed part is accurately insulated from the Power Supply by measuring the leakage current or the insulation resistance between them.

(2) Parts Replacement

Following parts shall be replaced with the specified ones. Refer to the parts list.

(a) Power Supply Circuit

Power Cord
Power Transformer: T1
Fuses: F401, 402

(b) Power Switch P.C.B. Ass'y

Power Switch: SW1
Spark Killer: M2

(c) Tape Switch P.C.B. Ass'y

Power Transistor: Q301
Fail Safe Type Resistor: R318, 350

(d) Main P.C.B. Ass'y

Regulator IC: IC402
Power Transistors: Q601, 607, 620, 624
Diode Bridge: D401
Fail Safe Type Resistors: R164, 264, 320, 403, 406, 612, 631

Thermal Fuse: TF1

7.2. IC Block Diagrams

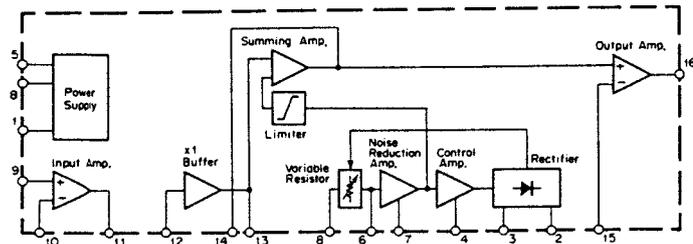

Fig. 7.2.1 Dolby NR IC μ A7300PC

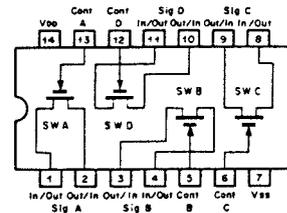

Fig. 7.2.5 Bilateral Switch C-MOS IC μ PD4066BC

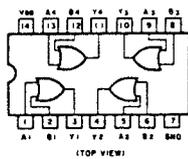

Fig. 7.2.2 OR Gate C-MOS IC μ PD4071BC

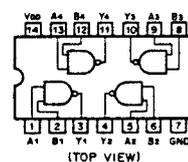

Fig. 7.2.3 NAND Gate C-MOS IC μ PD4011BC

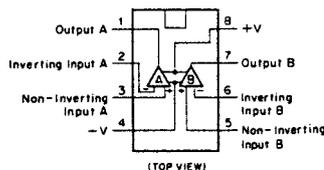

Fig. 7.2.4 Operational Amp. IC4556D, 2043DD, TL092

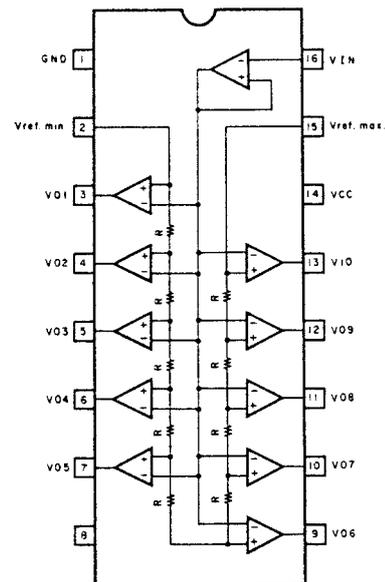

Fig. 7.2.6 Level Meter Driver TA7612AP

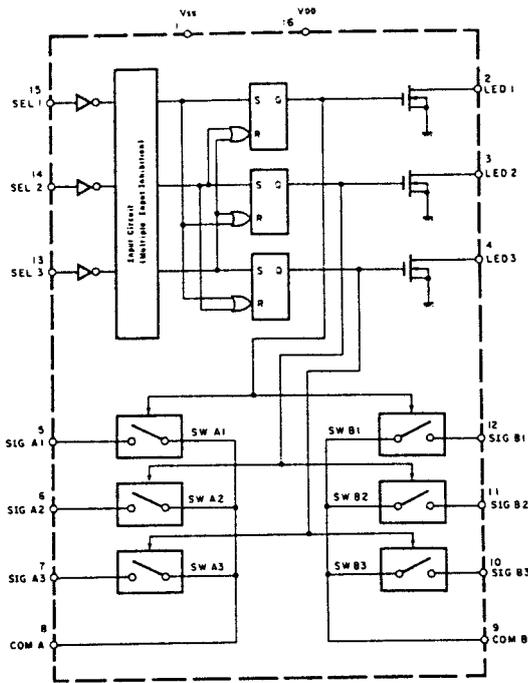

Fig. 7.2.7 Analog Switch Selector TC9145P

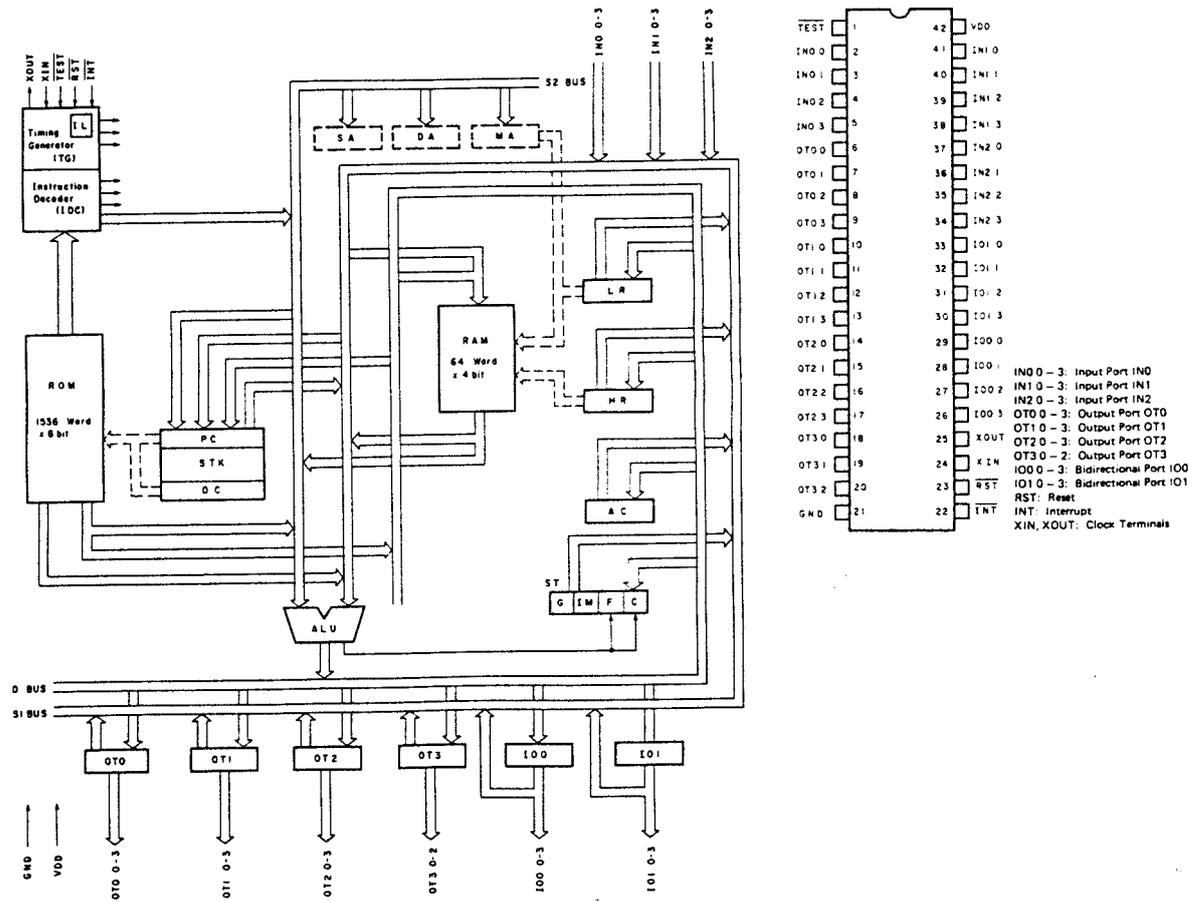
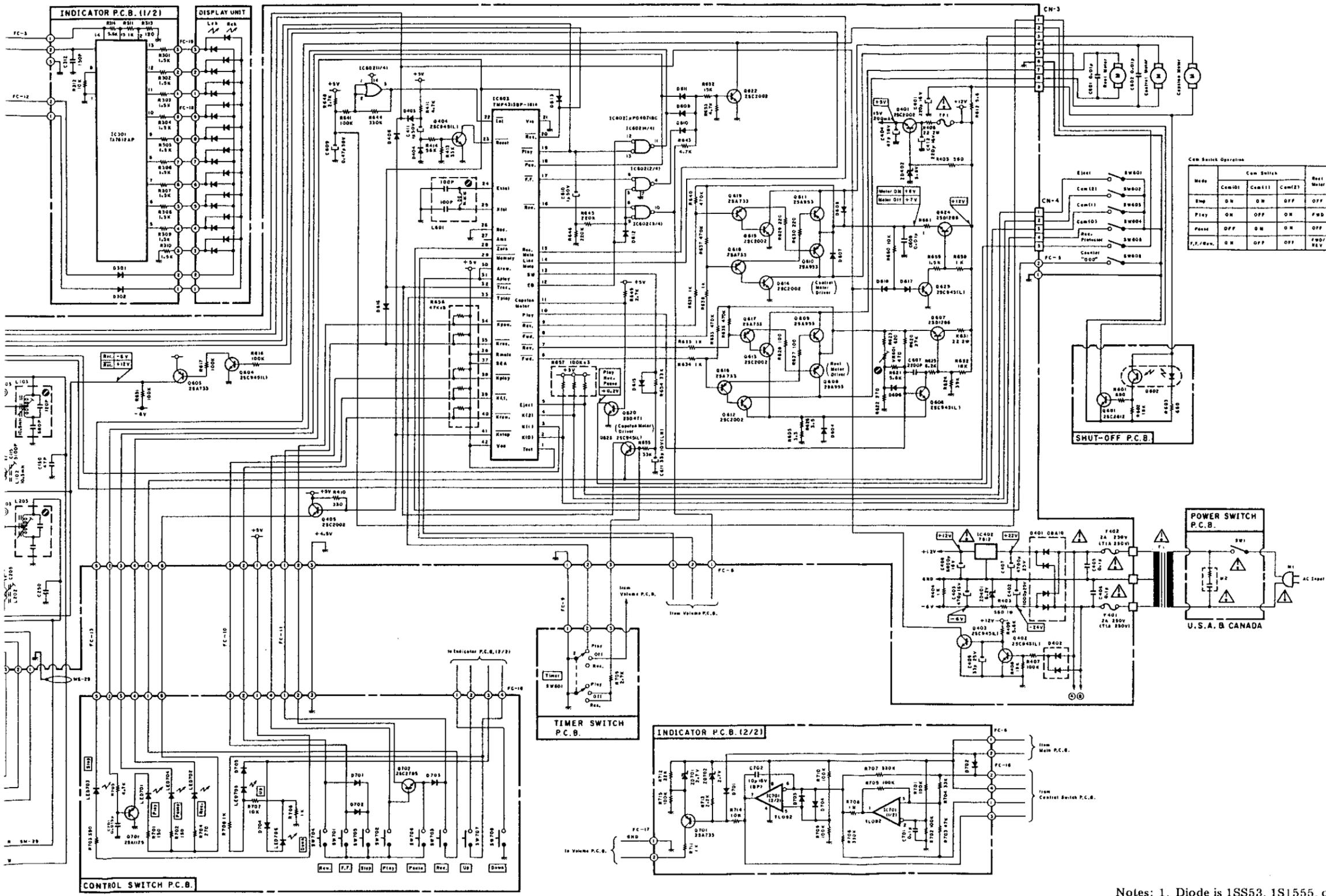
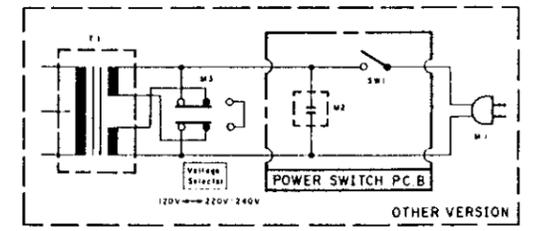
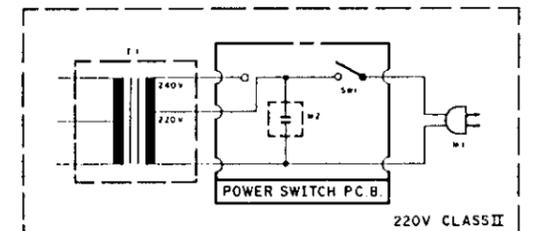
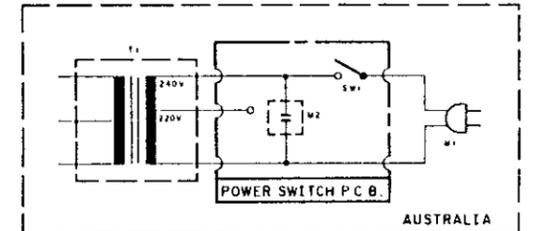
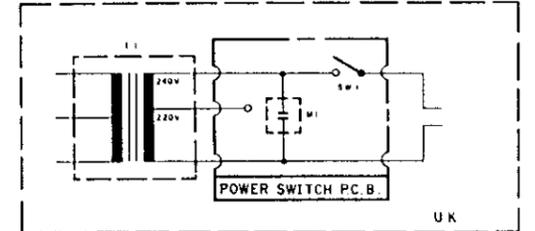

Fig. 7.2.8 4-bit Micro-processor TMP4315BP-1814



Cam Switch Operation

Mode	Cam101	Cam111	Cam121	Reel Motor
Emp	ON	ON	OFF	OFF
Play	ON	OFF	ON	FWD
F.F./Rev.	OFF	ON	ON	FFD/REV



WARNING:
 Parts marked with the symbol have critical characteristics. Use ONLY replacement parts recommended by the manufacturer. It is recommended that the unit be operated from a suitable DC supply or batteries during initial check-out procedures.

CAUTION:
 Before returning the unit to the customer, make sure you make either (1) a leakage current check or (2) a line to chassis resistance check. If the leakage current exceeds 0.5 milliamp, or if the resistance from chassis to either side of the power cord is less than 240 k ohms, the unit is defective. **WARNING — DO NOT** return the unit to the customer until the problem is located and corrected.

- Notes: 1. Diode is 1SS53, 1S1555, or 1SS176 unless otherwise specified.
 2. Resistor and capacitor marked with * show typical value.
 3. 2SA733, 2SA608SP, 2SA1048 and 2SA1175 are interchangeable with each other.
 4. 2SC945, 2SC536SP, 2SC2458 and 2SC2785 are interchangeable with each other.

Fig. 7.3

8. WIRING DIAGRAM

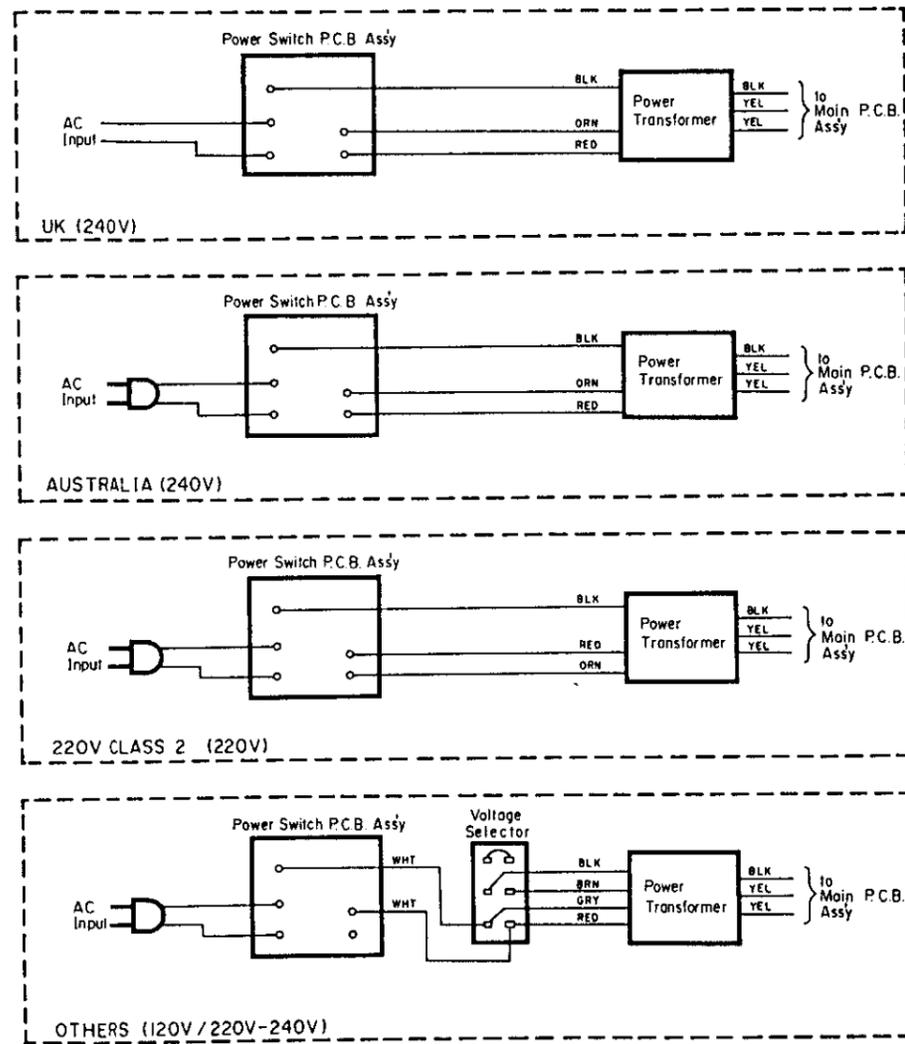

Notes: 1. Table of wire colors

BRN - Brown	BLU - Blue
RED - Red	VIO - Violet
ORN - Orange	GRY - Gray
YEL - Yellow	WHT - White
GRN - Green	BLK - Black

2. Component side view of the P.C.B. is illustrated unless otherwise specified.

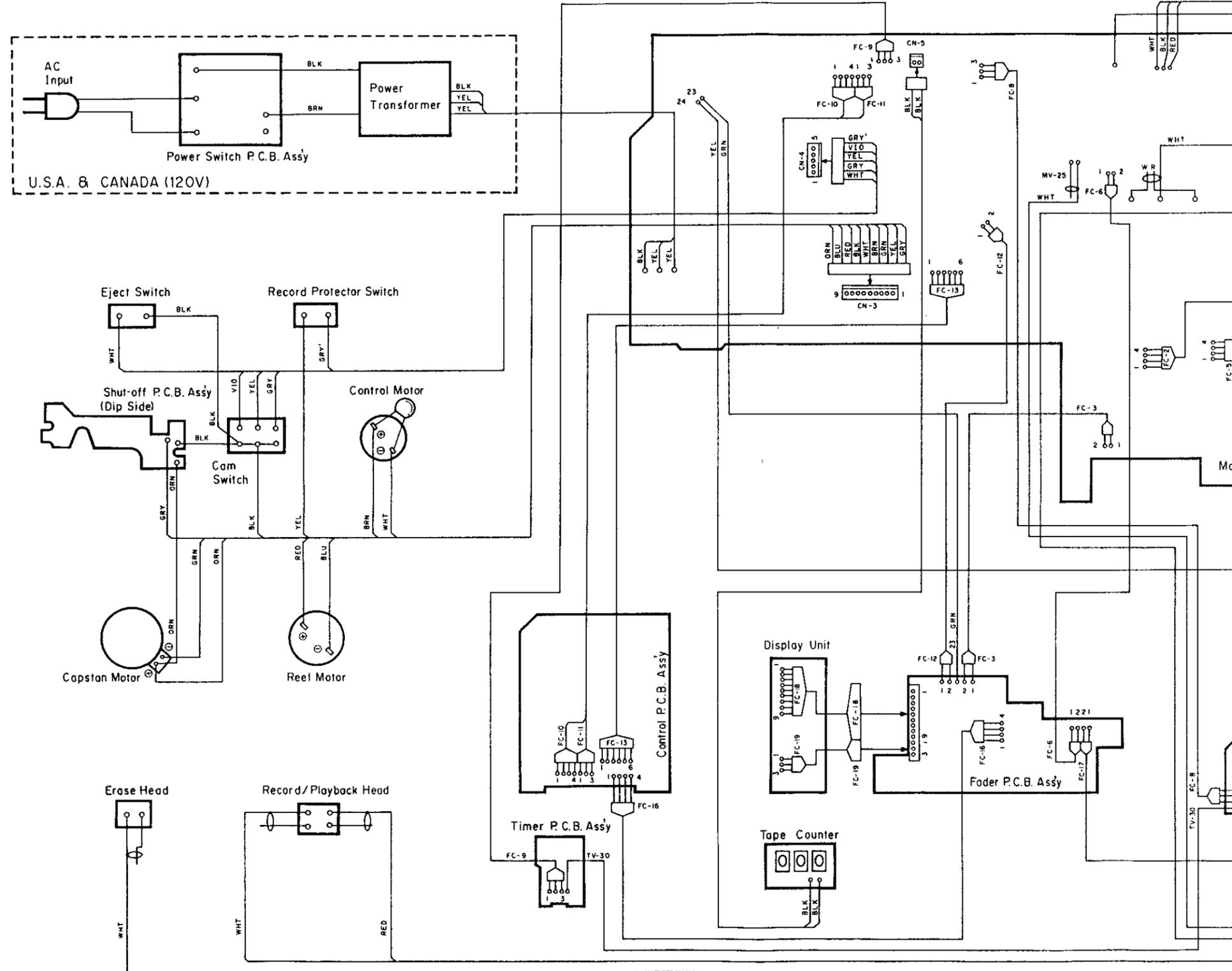

Fig. 8

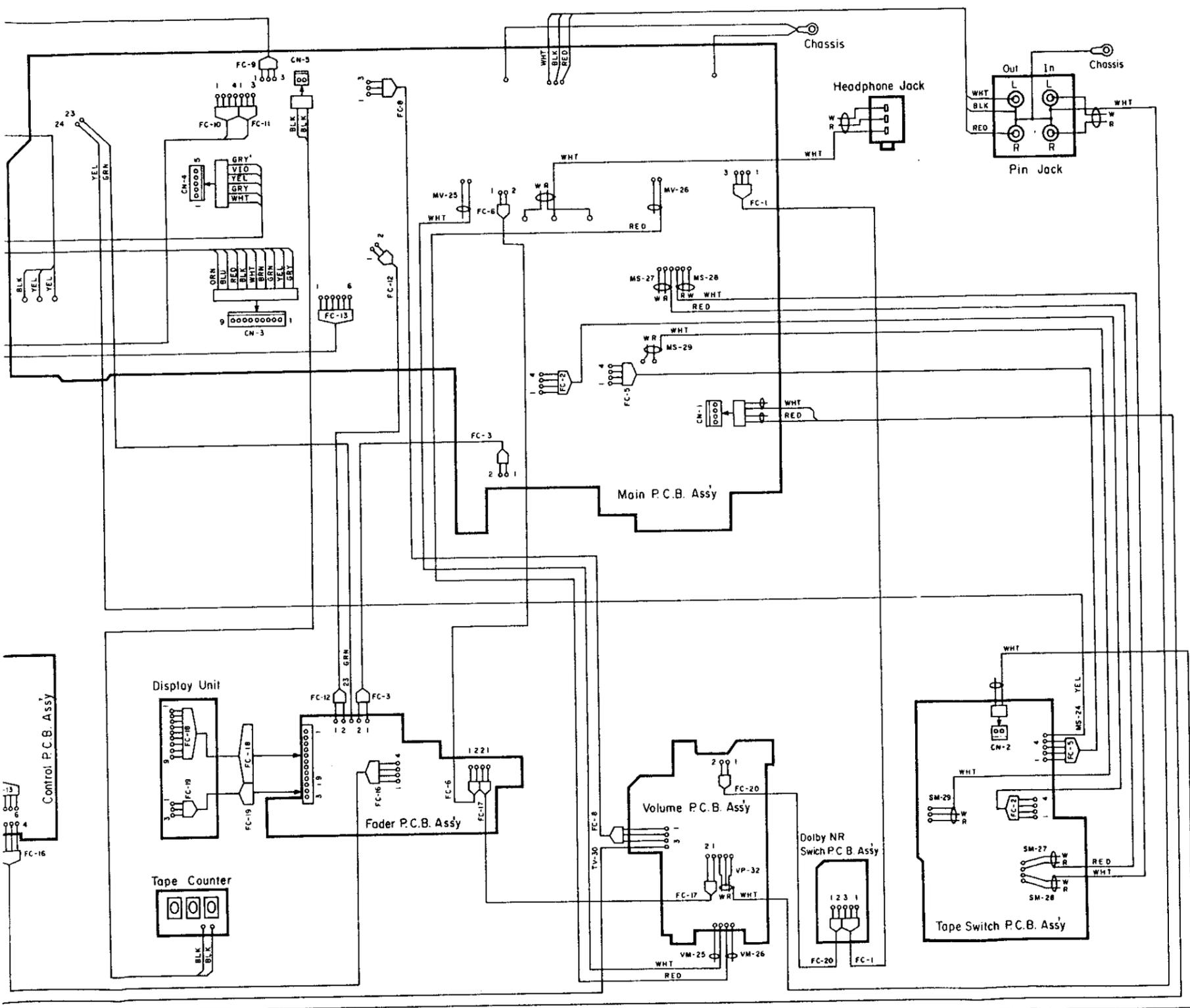

Fig. 8

9. BLOCK DIAGRAMS

9.1. Amplifier Section

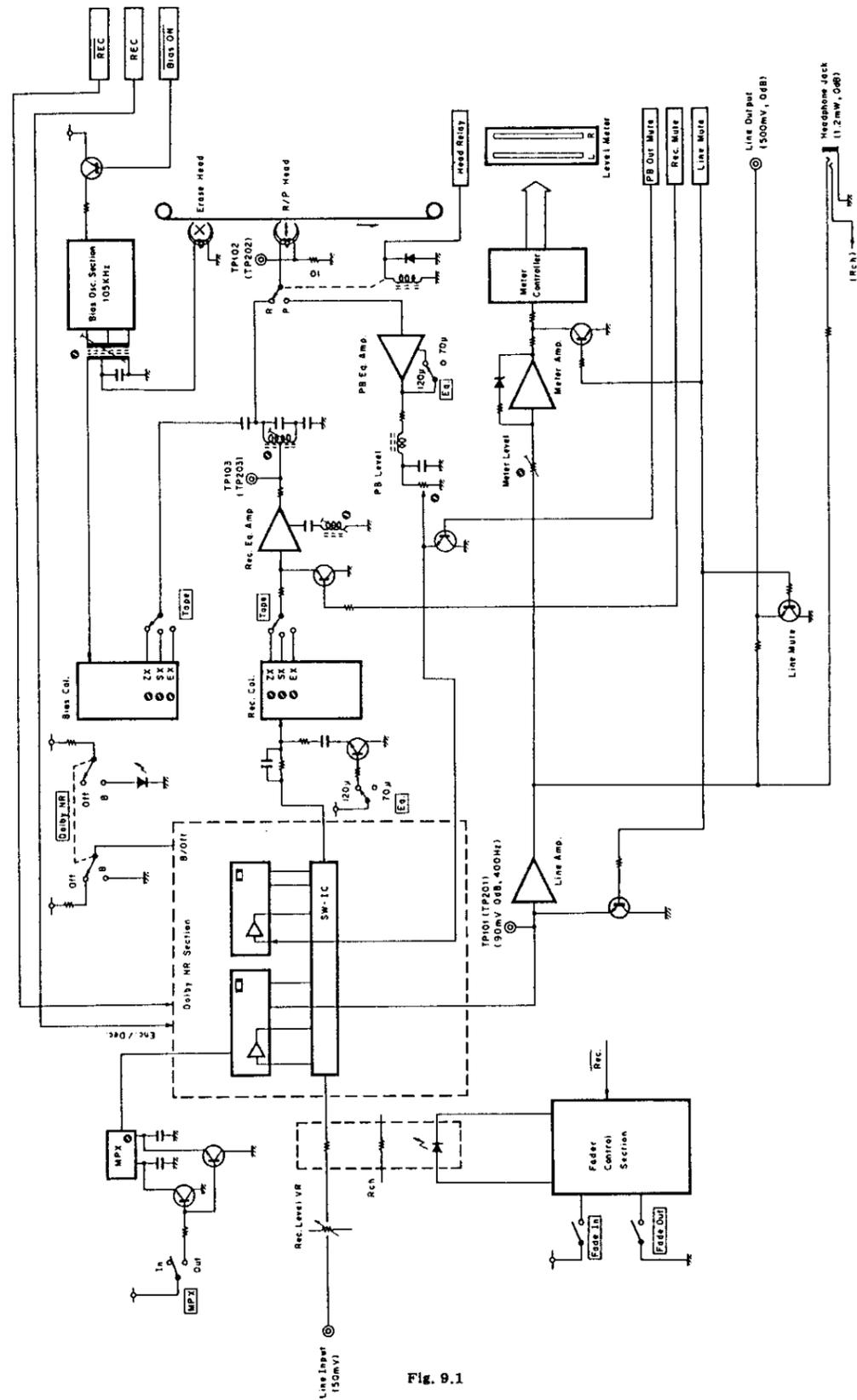

Fig. 9.1

9.2. Mechanism Control Section

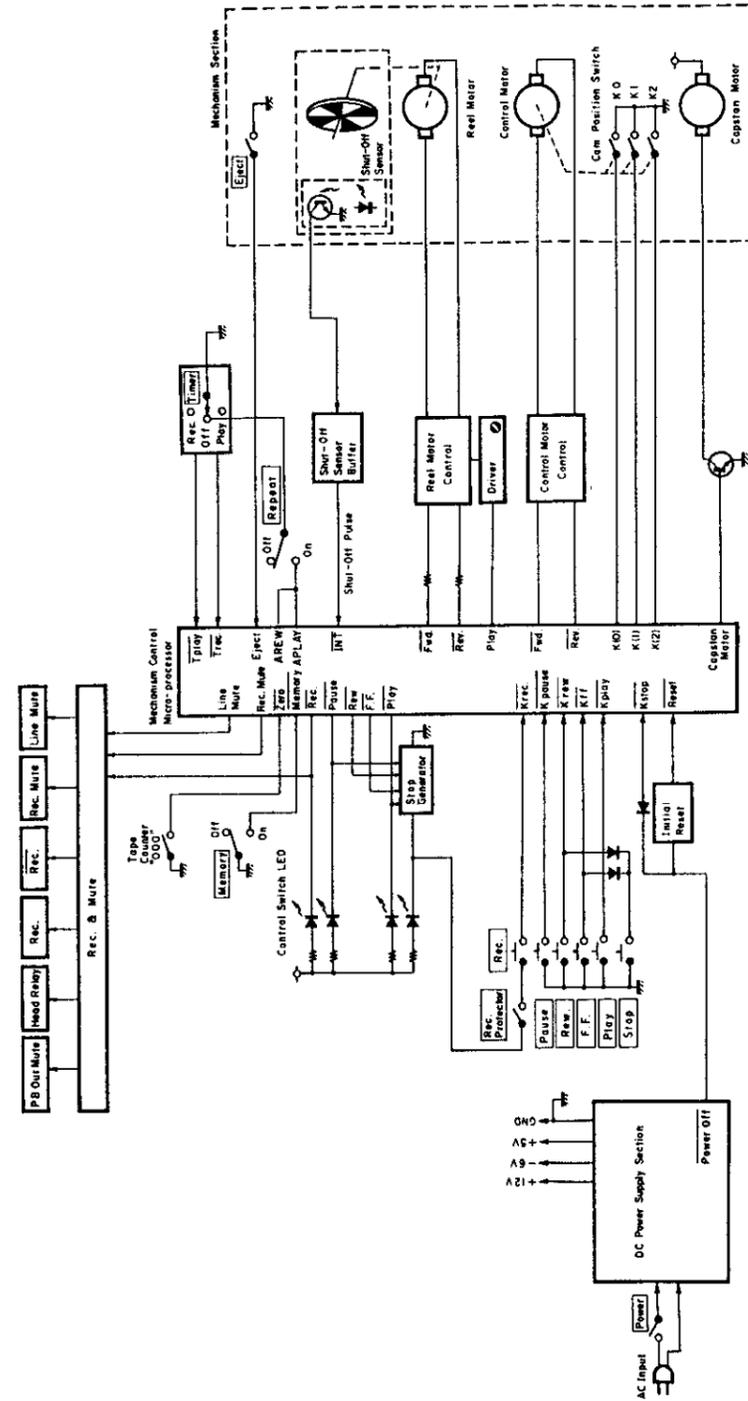

Fig. 9.2

10. TIMING CHART AND EQ. AMP. FREQUENCY RESPONSE

10.1. Timing Chart
(1) Overall Timing Chart

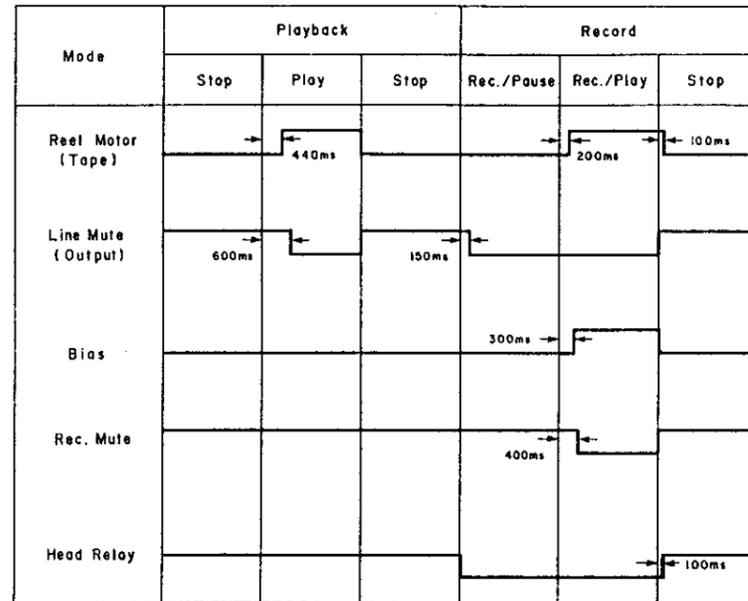

Fig. 10.1.1

(2) Mechanism Control Timing Chart

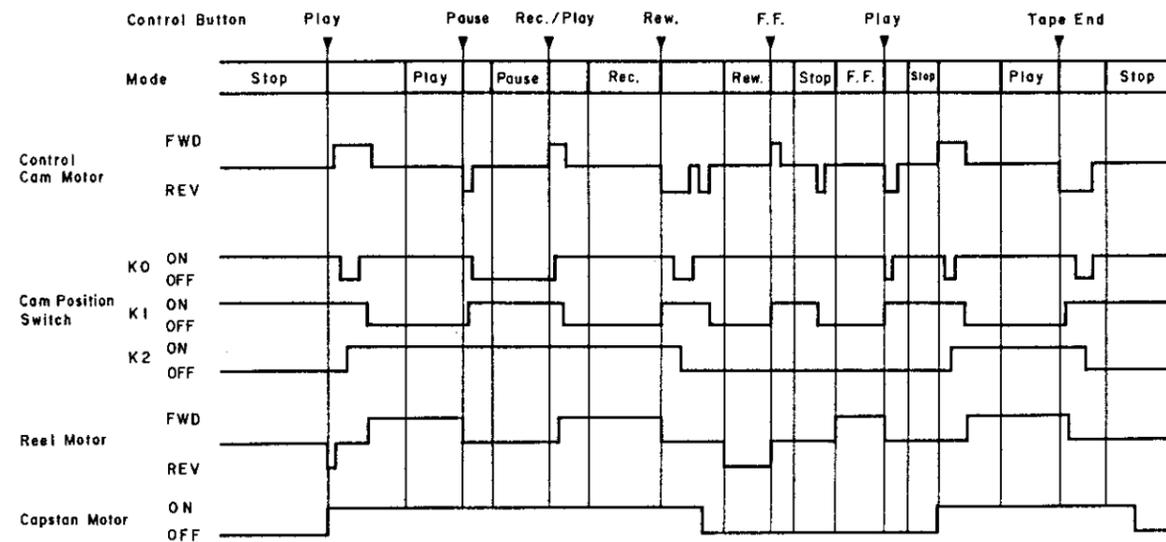

Fig. 10.1.2

10.2. Eq. Amp. Frequency Response
(1) Playback Frequency Response

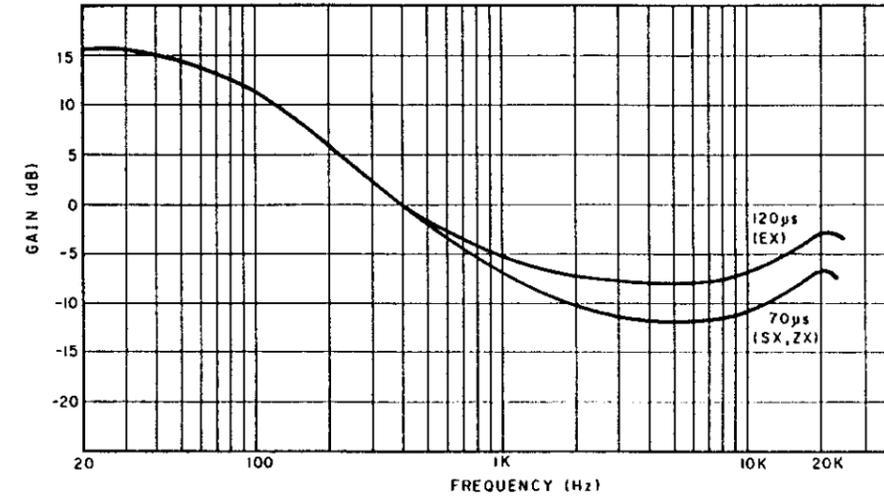

Fig. 10.2.1

(2) Record Current Frequency Response

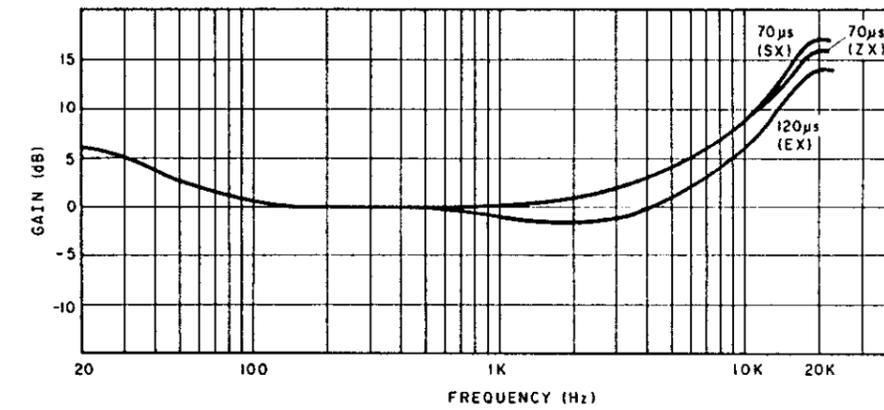

Fig. 10.2.2

11. SPECIFICATIONS

Track Configuration	4 Tracks/2-Channel Stereo
Heads	2 (Erase Head x 1, Record/Playback Head x 1)
Motors (Tape Transport)	DC Servo Motor (Capstan Drive) x 1 DC Motor (Reel Drive) x 1
Power Source	100, 120, 120/220-240, 220 or 240V AC; 50/60 Hz (According to country of sale)
Power Consumption	23 W max.
Tape Speed	1-7/8 ips. (4.8 cm/sec.) $\pm 0.5\%$
Wow-and-Flutter	Less than 0.11% WTD Peak Less than 0.06% WTD RMS
Frequency Response	20 Hz—20,000 Hz (recording level -20 dB)
Signal-to-Noise Ratio	Dolby B-Type NR on <70 μ s, ZX tape> Better than 62 dB (400 Hz, 3% THD, IHF A-WTD RMS)
Total Harmonic Distortion	Less than 1.0% (400 Hz, 0 dB, ZX, EXII tape) Less than 1.2% (400 Hz, 0 dB, SX tape)
Erasure	Better than 60 dB (100 Hz, 0 dB)
Separation	Better than 36 dB (1 kHz, 0 dB)
Crosstalk	Better than 60 dB (1 kHz, 0 dB)
Bias Frequency	105 kHz
Input (Line)	50 mV, 30 k Ω
Output (Line)	0.5 V (400 Hz, 0 dB) 2.2 k Ω
(Headphones)	1.2 mW (400 Hz, 0 dB) 8 Ω load
Fast-Winding Time	Approx. 85 seconds (with C-60 cassette)
Dimensions	430 (W) x 110 (H) x 250 (D) millimeters 16-15/16 (W) x 4-5/16 (H) x 9-7/8 (D) inches
Approximate Weight	5.5 kg 12 lb. 2 oz

- Specifications and appearance design are subject to change for further improvement without notice.
- Noise Reduction System manufactured under license from Dolby Laboratories Licensing Corporation.
- The word "DOLBY" and the Double-D-Symbol are trademarks of Dolby Laboratories Licensing Corporation.