



Service Manual

Nakamichi BlackBox Series

PS-100	Power Supply
SF-100	Sub-sonic Filter
LA-100	Line Amplifier
BA-150	Bridging Adaptor
MB-150	MC Booster Amplifier
EC-100	Electronic Crossover
MX-100	Microphone Mixer

CONTENTS

1. PS-100 Power Supply	1
General, Mute Signal, Specifications, Schematic Diagram, Mounting Diagram and Parts List, Mechanism Ass'y and Parts List	
2. SF-100 Sub-sonic Filter	5
General, Specifications, System Diagram, Schematic Diagram, Mounting Diagram and Parts List, Mechanism Ass'y and Parts List	
3. LA-100 Line Amplifier	8
General, Specifications, System Diagram, Schematic Diagram, Mounting Diagram and Parts List, Mechanism Ass'y and Parts List	
4. BA-150 Bridging Adaptor	11
General, Specifications, System Diagram, Schematic Diagram, Mounting Diagram and Parts List, Mechanism Ass'y and Parts List	
5. MB-150 MC Booster Amplifier	14
General, Specifications, System Diagram, Schematic Diagram, Mounting Diagram and Parts List, Mechanism Ass'y and Parts List	
6. EC-100 Electronic Crossover	17
General, Specifications, System Diagram, Schematic Diagram, Mounting Diagram and Parts List, Mechanism Ass'y and Parts List	
7. MX-100 Microphone Mixer	20
General, Specifications, System Diagram, Schematic Diagram, Mounting Diagram and Parts List, Mechanism Ass'y and Parts List	

1. PS-100 POWER SUPPLY

General

PS-100 Power Supply

PS-100 is a regulated power supply unit designed to be a power supply for the BlackBox Series (the rated output current: ± 200 mA).

Although PS-100 is provided only with one output terminal, two input/output terminals on the other units of the BlackBox Series make multiple connection of PS-100 possible.

To prevent noise signal generation on switching ON/OFF the power supply, PS-100 produces a mute signal, muting output terminals of each unit furnished with a muting circuit.

Refer to Table 1 showing how many units of the Black-Box Series can be driven by a single PS-100.

Mute Signal

Mute signal is muted for a certain period of time to prevent transient noise when power is ON or OFF.

Power ON

Transformer output is rectified through diode D403 and smoothed by capacitor C408. Therefore, positive potential appears at C408 (transistor Q411 base). Accordingly, Q411 is in the cutoff state. C409 (22 μ F) is charged with negative potential through R414 (1 M Ω), therefore at the level where the voltage across C409 exceeds V_{be} (base-emitter voltage) of Q412, Q412 turns from OFF to ON.

As a result, Q413 turns on and the mute signal is changed from + V to -10 V, releasing the mute state.

(The mute time depends on C409 and R414 after power is ON.)

Power OFF

Transformer output becomes zero and so C408 is charged with negative potential through R415. At the level where the voltage across C408 exceeds V_{be} of Q411, Q411 turns from OFF to ON and C409 is quickly discharged. Thus, Q412 is cut off and Q413 is also cut off. Therefore the mute signal becomes + V (i.e. mute state). D402 acts to prevent + V from being discharged easily when power is OFF.

Specifications

Maximum Power Consumption . . .	20 VA
Output Voltage	± 10 V
Rated Output Current	± 200 mA
Dimensions	7-1/2(W) x 2-3/8(H) x 3-15/16(D) inches 190(W) x 60(H) x 99(D) mm
Weight	3.5 lb, 1.6 kg

Table 1 Combinations of Units Driven by a single PS-100

Type	PS-100 Power Supply	SF-100 Sub-sonic Filter	LA-100 Line Amplifier	BA-150 Bridging Adaptor	MB-150 MC Booster Amplifier	EC-100 Electronic Crossover	MX-100 Microphone Mixer
Rating	4 VA (±200 mA)	0.5 VA (±25 mA)	0.5 VA (±25 mA)	1 VA (±50 mA)	2 VA (±100 mA)	1 VA (±50 mA)	2 VA (±100 mA)
Combination	1	○	○	○	○		
	2	○	○	○			○
	3	○	○	○		○	○
	4	○	○	○		○	
	5				○	○	
	6				○	○	○
	7					○	○
Maximum Drivable Number of Units		8	8	4	2	4	2

Schematic Diagram

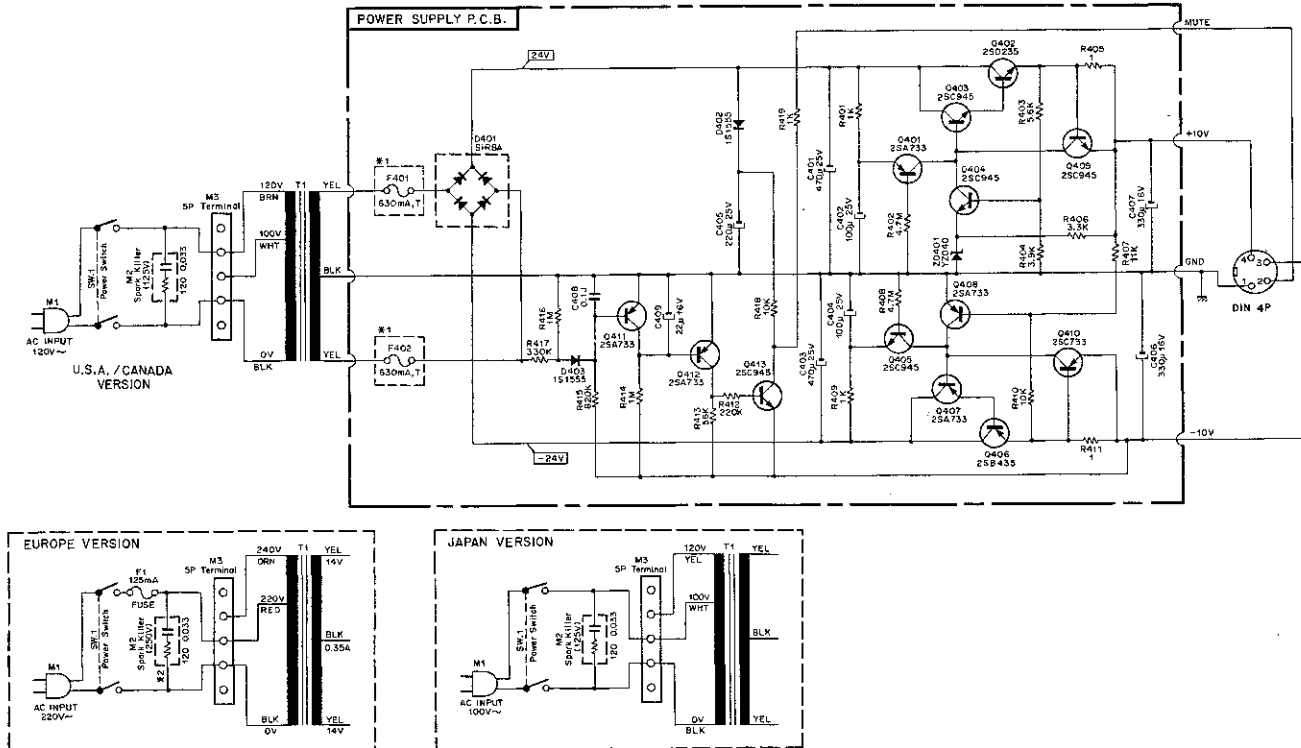

Fig. 1.1

- Notes: 1. Fuses marked with *1 are not incorporated in the U.S.A. version.
 2. The type of spark killer marked with *2 differs in some countries.

Mounting Diagram and Parts List

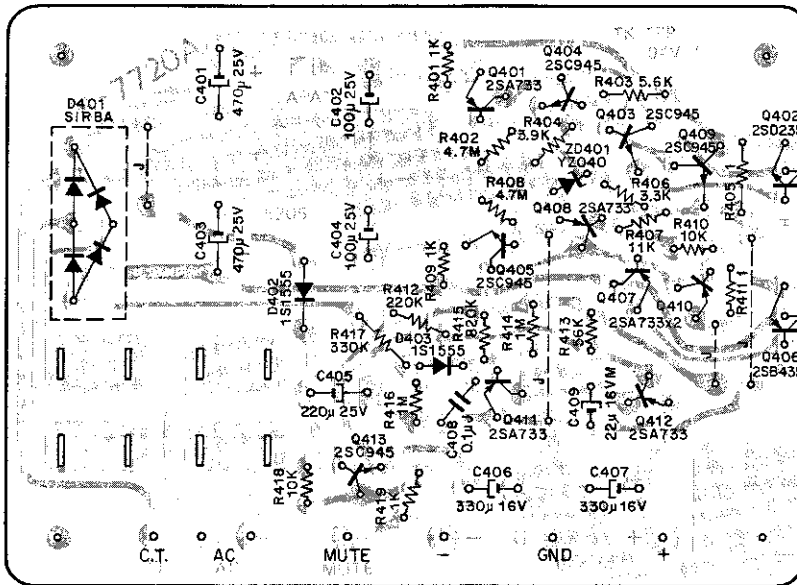

Fig. 1.2

Schematic Ref. No.	Part No.	Description	Schematic Ref. No.	Part No.	Description
	BA03855A	PS-100 P.C.B. Ass'y			
	OB07720A	Power Supply P.C.B.			
Q401,407 408,410 411,412	OB06013A	Transistor 2SA733	C405	OB01391A	Electrolytic Capacitor 220 μ 25V
Q402	OB01823A	Transistor 2SD235 (Y)	C406,407	OB01502A	Electrolytic Capacitor 330 μ 16V
Q403,404 405,409 413	OB01872A	Transistor 2SC945	C408	OB01780A	Mylar Capacitor 0.1 μ 50V J
Q406	OB06011A	Transistor 2SB435	C409	OB05820A	Electrolytic Capacitor 22 μ 16V M (MS)
D401	OB06088A	Silicon Diode S1RBA		0J03597B	Heat Sink (1 pce.)
D402,403	OB01909A	Silicon Diode 1S1555		0E00607A	Screw M3x8 Philips Pan Head (3A) (4 pcs.)
ZD401	OB06063A	Zener Diode YZ040B		0E00507A	Nut Hex. M3 (2 pcs.)
R401,409 419	OB01781A	Carbon Resistor 1K ERD-25V J			
R402,408	OB05824A	Carbon Resistor 4.7M ERD-50T J			
R403	OB05673A	Carbon Resistor 5.6K ERD-25V J			
R404	OB05664A	Carbon Resistor 3.9K ERD-25V J			
R405,411	OB05746A	Carbon Resistor 1 ERD-25V J			
R406	OB01793A	Carbon Resistor 3.3K ERD-25V J			
R407	OB05826A	Carbon Resistor 11K ERD-25V J			
R410,418	OB01833A	Carbon Resistor 10K ERD-25V J			
R412	OB05596A	Carbon Resistor 220K ERD-25V J			
R413	OB05563A	Carbon Resistor 56K ERD-25V J			
R414,416	OB05564A	Carbon Resistor 1M ERD-25V J			
R415	OB05674A	Carbon Resistor 820K ERD-25V J			
R417	OB01921A	Carbon Resistor 330K ERD-25V J			
C401,403	OB01401A	Electrolytic Capacitor 470 μ 25V			
C402,404	OB01272A	Electrolytic Capacitor 100 μ 25V			

Mechanism Ass'y and Parts List

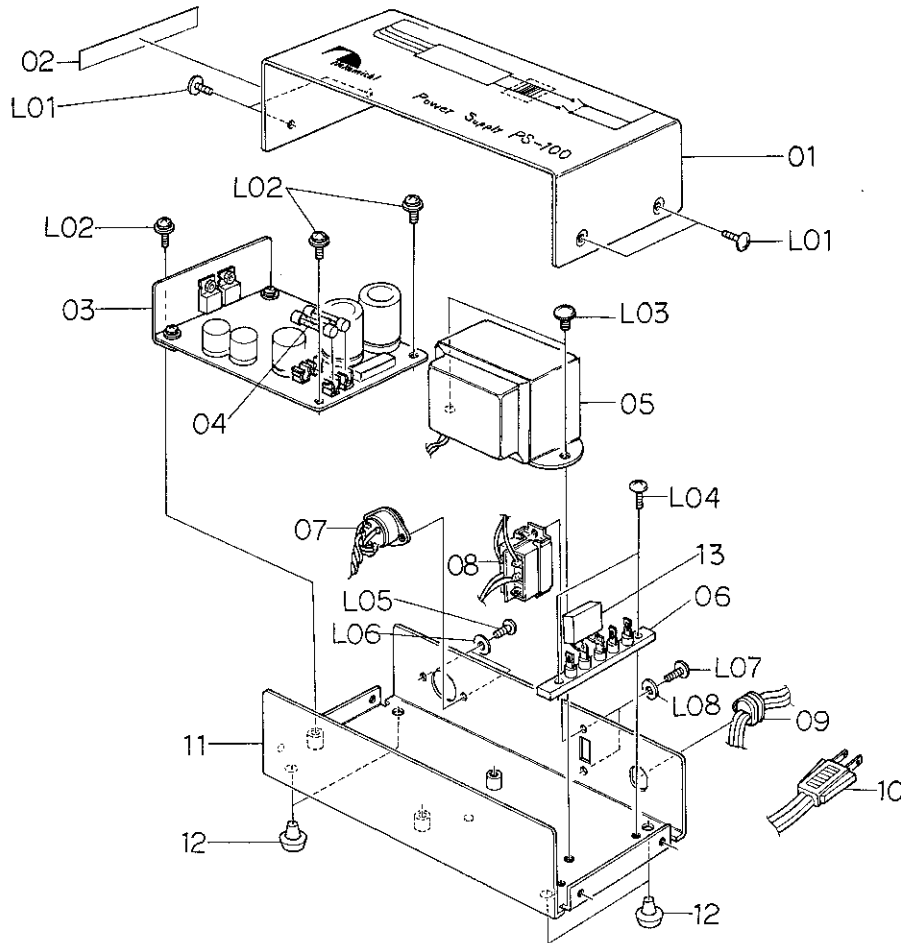

Fig. 1.3

Schematic Ref. No.	Part No.	Description	Q'ty	Schematic Ref. No.	Part No.	Description	Q'ty
		PS-100 Mechanism		11	HA03697C	Main Chassis PS Ass'y	1
				12	0H03437A	Rubber Foot	4
01	0H03509A	Upper Cover PS	1	13	0B08361A	Spark Killer 125 V (R + C)	1
02	0M03799A	Caution Label G	1		0B08363A	Spark Killer 125 V (R + C)	1
	0M03800A	Caution Label H	1		0B08342A	Spark Killer 125 V (R + C)	1
03	BA03855A	PS-100 P.C.B. Ass'y	1		0B08240A	Spark Killer 250 V (R + C)	1
04	0B08161U	Fuse 630 mA	2		0B07096U	Spark Killer (C)	1
05	0B06567A	Power Transformer 100-120 V	1	L01	0E00713A	Screw M3x6 Philips Truss Head	4
	0B06568A	Power Transformer 220-240 V	1	L02	0E00606A	Screw M3x6 Philips Pan Head (3A)	3
06	0B08025U	5P Terminal	1	L03	0E00538A	Screw M4x5 Philips Binding Head	2
07	0B08355A	4P DIN Socket	1	L04	0E00594A	Screw M3x8 Philips Binding Head	2
08	0B07172A	Power Switch	1	L05	0E00714A	Screw M2.6x6 Philips Binding Head	2
	0B07092A	Power Switch	1	L06	0E00651A	Washer 2.6 mm (plastics)	2
09	0B08037A	Cord Bushing	1	L07	0E00593A	Screw M3x6 Philips Binding Head	2
	0B08351A	Cord Bushing	1	L08	0E00157A	Washer 3 mm (plastics)	2
	0B08325A	Cord Bushing	1				
10	0B08350A	Power Cord	1				
	0B08219B	Power Cord	1				
	0B08348A	Power Cord	1				
	0B08149U	Power Cord	1				

Notes: 1. 02, 08, 09 and 10 differ in versions.
2. 04 (fuse) is not incorporated in the U.S.A. version.

2. SF-100 SUB-SONIC FILTER

General

In disc record reproduction, low-frequency resonance of a tone arm and rumbling of a turn table exist at about 10 Hz and their peak level ranges approximately from 5 to 15 dB.

SF-100 is an active filter to eliminate these noises.

The unit is designed so that no low frequency sound recorded on disc records is sacrificed and no change in tones is effected.

To compensate the personal feeling of insufficiency in low frequency sound caused by the insertion of the Sub-sonic Filter, a Low Boost Switch is provided which can boost signal approximately by 5 dB at 30 Hz.

With both of the Filter Switch and Low Boost Switch turned OFF, the input signal directly appears on the output terminals without passing through the Sub-sonic Filter.

The output of the twin-T filter is amplified by Amplifier 2, while the output of the amplifier is positively fed back through C_2 and R_2 to compensate the level reduction in the range of 20–50 Hz.

Further, to increase the attenuation below 5 Hz, the filter load impedance is lowered with R_4 , and the improvement of characteristics can be realized by changing impedance of every device.

In addition, a high pass filter is incorporated in the input side of Amplifier 1 to ensure an ideal sub-sonic filtering characteristics.

Specifications

Maximum Power Consumption	0.5 VA
Current Consumption	25 mA
Total Harmonic Distortion	less than 0.005% (50 Hz – 20 kHz, 1 V Output)
Frequency Response	40 Hz – 100 kHz \pm 0.5 dB
Sub-sonic Filter	10 Hz: –50 dB, –40 dB (with Low Boost)
Low Boost	30 Hz: + 5 dB
Signal-to-Noise Ratio	better than 110 dB (IHF-A Network)
Mute Function	Furnished
Dimensions	7-1/2(W) x 2-3/8(H) x 4-1/16(D) inches 190(W) x 60(H) x 103(D) mm
Weight	2.7 lb, 1.2 kg

System Diagram

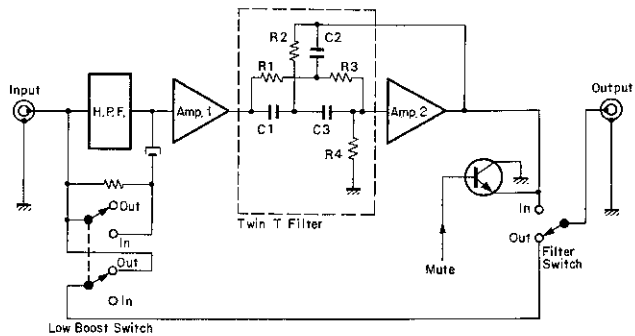

Fig. 2.1

Schematic Ref. No.	Part No.	Description	Schematic Ref. No.	Part No.	Description
	BA03849A	SF-100 P.C.B. Ass'y	R114,115	0B05562A	Carbon Resistor 47K ERD-25V J
	0B07719A	SF P.C.B.	119,214		
Q101,102	0B06062A	Transistor 2SC1222 (2)	215,219	0B05678A	Carbon Resistor 560 ERD-25V J
Q103,104	0B06013A	Transistor 2SA733	R117,118	0B05567A	Carbon Resistor 33 ERD-25V J
Q105,205	0B01872A	Transistor 2SC945 (L)	217,218		
D101,102	0B01909A	Silicon Diode 1S1555	C101,201	0B05682A	Mylar Capacitor 0.068 μ 50V J
103,201			C102,202	0B01863A	Electrolytic Capacitor 3.3 μ 16V
202,203			C103,105	0B05844A	Mylar Capacitor 0.33 μ 50V J
R101,201	0B05700A	Carbon Resistor 470K ERD-25V J	C104,204	0B05832A	Mylar Capacitor 0.018 μ 50V J
R102,202	0B05564A	Carbon Resistor 1M ERD-25V J	C106,206	0B05639A	Electrolytic Capacitor 1.5 μ 35V M (MS)
R103,203	0B05563A	Carbon Resistor 56K ERD-25V J			
R104,204	0B05608A	Carbon Resistor 220 ERD-25V J	C107,108	0B05884A	Electrolytic Capacitor 470 μ 10V
R105,205	0B01789A	Carbon Resistor 330 ERD-25V J	207,208		
R106,206	0B05564A	Carbon Resistor 3.9K ERD-25V J			
R107,207	0B01564A	Carbon Resistor 82K ERD-25V J			
R108,109	0B01921A	Carbon Resistor 330K ERD-25V J	CN1	0B07167A	Push Switch (1 pce.)
208,209			CN2	0B08182A	6P-T Post
R110,210	0B01795A	Carbon Resistor 4.7K ERD-25V J		0B08236A	4P-T Post
R111,211	0B01902A	Carbon Resistor 68K ERD-25V J			
R112,212	0B05569A	Carbon Resistor 47 ERD-25V J			
R113,213	0B05565A	Carbon Resistor 1.2K ERD-25V J			

Schematic Diagram

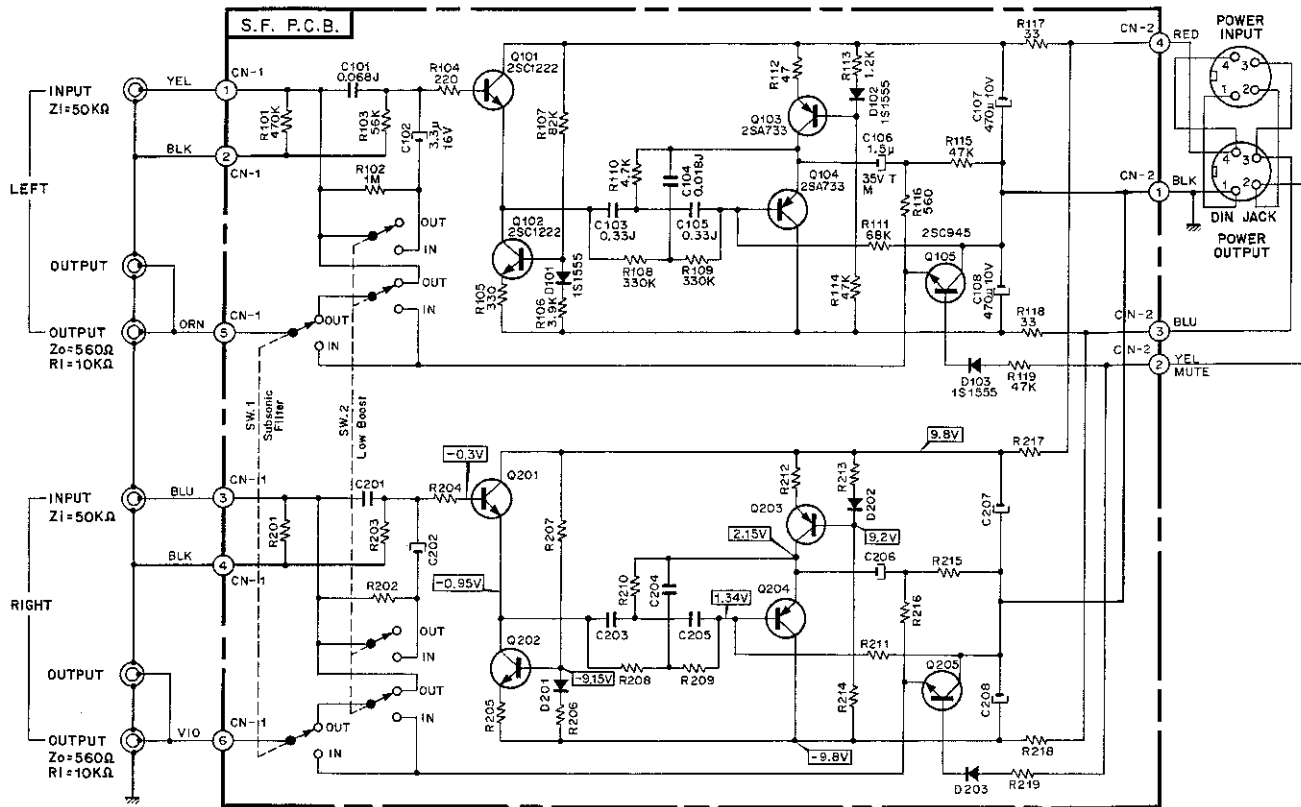

Fig. 2.2

Mounting Diagram and Parts List

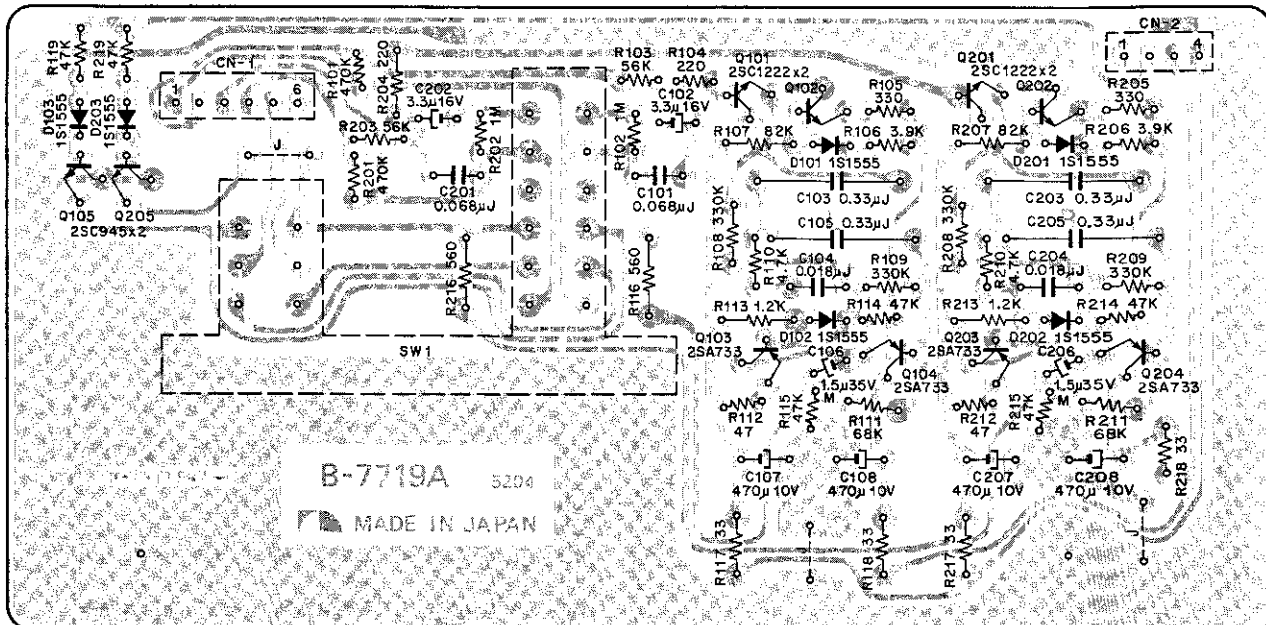

Fig. 2.3

Mechanism Ass'y and Parts List

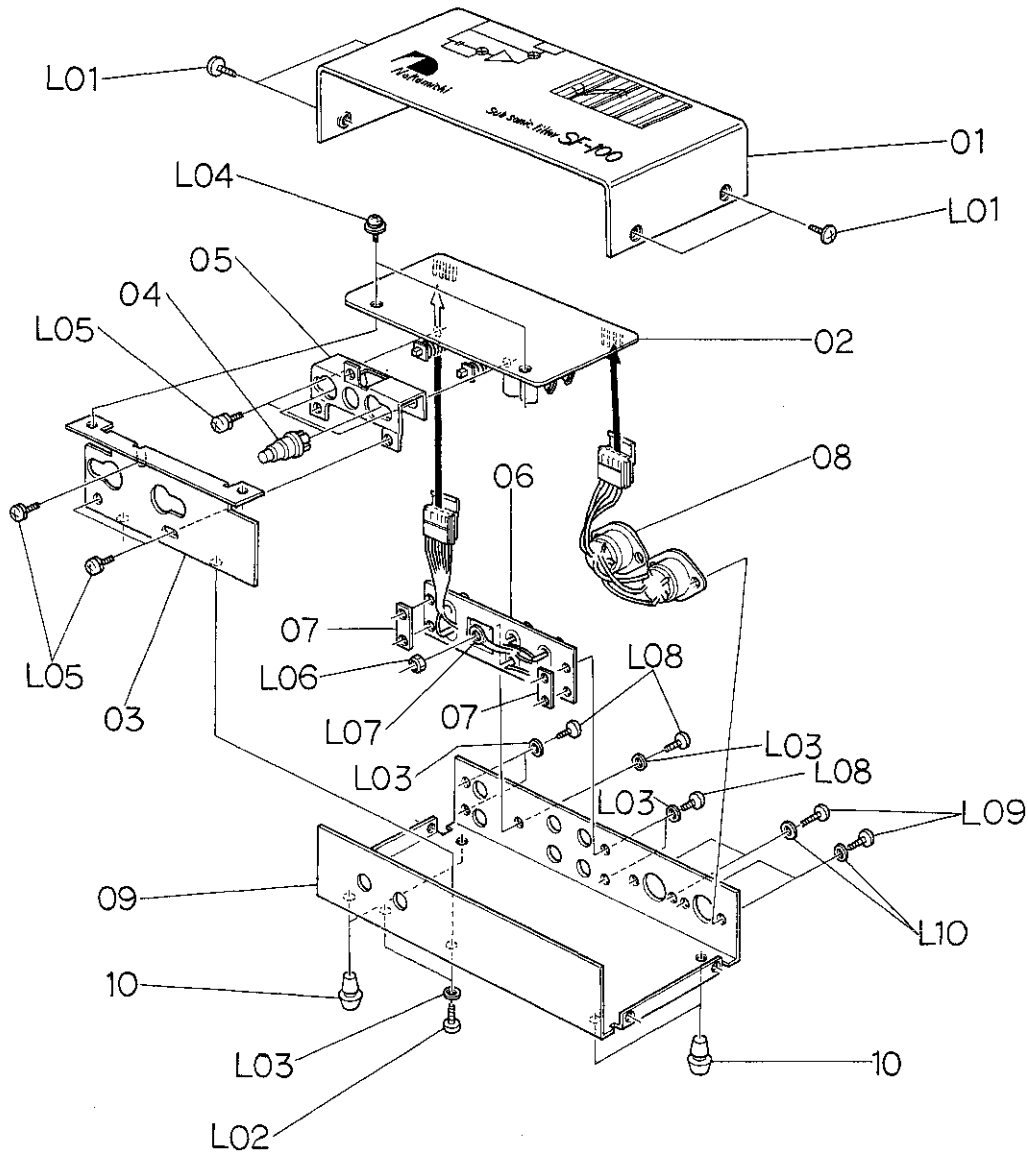

Fig. 2.4

Schematic Ref. No.	Part No.	Description	Q'ty	Schematic Ref. No.	Part No.	Description	Q'ty
		SF-100 Mechanism		L03	0E00157A	Washer 3 mm (plastics)	7
01	0H03507A	Upper Cover SF	1	L04	0E00606A	Screw M3x6 Philips Pan Head (3A)	2
02	BA03849A	SF-100 P.C.B. Ass'y	1	L05	0E00612A	Screw M3x6 Philips Pan Head (2A)	5
03	0J03654B	Front Chassis	1	L06	0E00507A	Nut Hex. M3	1
04	JA03061A	Push Button Ass'y	2	L07	0E00037A	Earth Lug B-5	1
05	0J03440A	Switch E Block Base	1	L08	0E00594A	Screw M3x8 Philips Binding Head	5
06	0B08290B	6P Pin Jack	1	L09	0E00714A	Screw M2.6x6 Philips Binding Head	4
07	0J03277A	Metal Seat Nut	2	L10	0E00651A	Washer 2.6 mm (plastics)	4
08	0B08355A	4P DIN Socket	2				
09	0H03508B	Main Chassis SF	1				
10	0H03437A	Rubber Foot	4				
L01	0E00713A	Screw M3x6 Philips Truss Head	4				
L02	0E00593A	Screw M3x6 Philips Binding Head	2				

3. LA-100 LINE AMPLIFIER

General

LA-100 is an amplifier with a flat frequency response that may be inserted between amplifiers connected to input or output of a tape deck or the like when the gain of the amplifiers is insufficient.

The gain is selectable at four levels, 0, +6, +12, and +18 dB by combination of IN/OUT of two gain switches of 6 dB and 12 dB.

The voltage amplification of LA-100 at each status of the switches is as follows:

S_1 : open, S_2 : close;

$$A_{V(1)} = \frac{9.1 \text{ k} // 27 \text{ k}}{6.8 \text{ k}} \approx 1 \text{ [0 dB]}$$

S_1 : close, S_2 : close;

$$A_{V(2)} = \frac{9.1 \text{ k} // 27 \text{ k}}{6.8 \text{ k} // 6.8 \text{ k}} \approx 2 \text{ [6 dB]}$$

S_1 : open, S_2 : open;

$$A_{V(3)} = \frac{(1\text{M} + 9.1 \text{ k}) // 27 \text{ k}}{6.8 \text{ k}} \approx 4 \text{ [12 dB]}$$

S_1 : close, S_2 : open;

$$A_{V(4)} = \frac{(1\text{M} + 9.1 \text{ k}) // 27 \text{ k}}{6.8 \text{ k} // 6.8 \text{ k}} \approx 8 \text{ [18 dB]}$$

Specifications

Maximum Power Consumption	1 VA
Current Consumption	50 mA
Total Harmonic Distortion	0.005% (20 Hz – 20 kHz, 1 V Output)
Frequency Response	10 Hz – 75 kHz + 0, –0.5 dB
Signal-to-Noise Ratio	better than 100 dB (+18 dB Gain)
Reference Level	Gain Switch 0 dB: 1V 6 dB: 0.5 V 12 dB: 0.25 V 18 dB: 0.126 V
Input Impedance	50 k Ω
Output Level/Output Impedance . . .	1 V/560 Ω
Mute Function	Furnished
Dimensions	7-1/2(W) x 2-3/8(H) x 4-1/16(D) inches 190(W) x 60(H) x 103(D) mm
Weight	2.7 lb, 1.2 kg

System Diagram

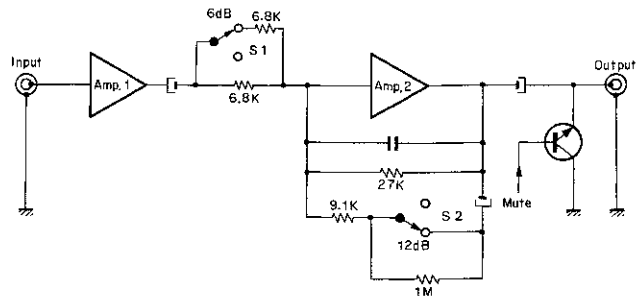

Fig. 3.1

Schematic Diagram

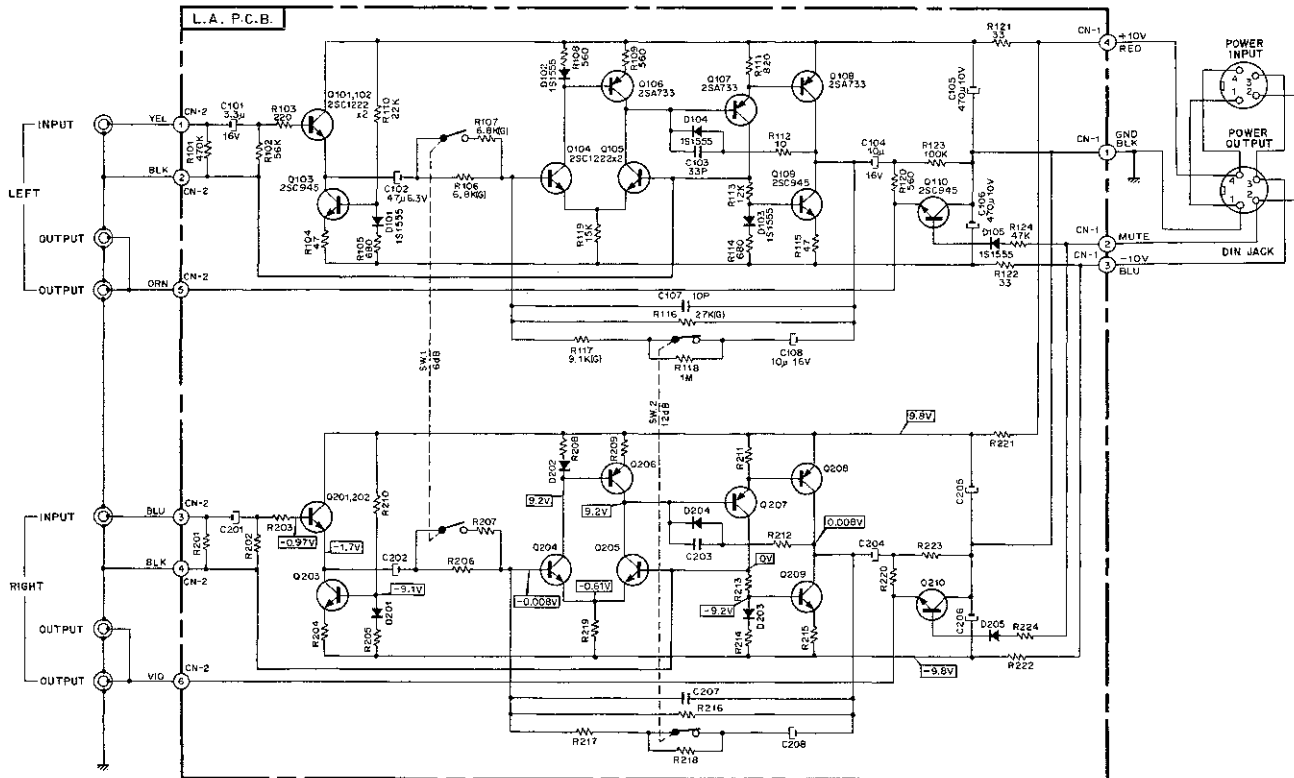

Fig. 3.2

Mounting Diagram and Parts List

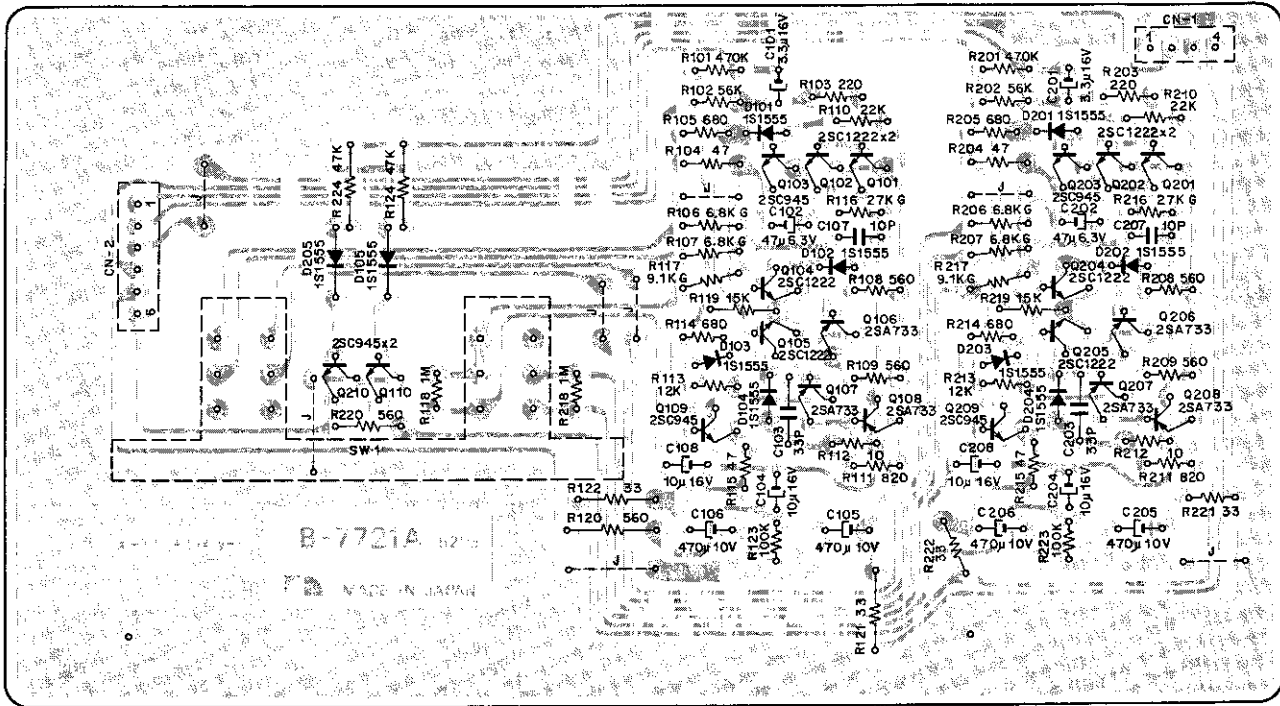

Fig. 3.3

Schematic Ref. No.	Part No.	Description	Schematic Ref. No.	Part No.	Description
	BA03859A	LA-100 P.C.B. Ass'y	R110,210	0B05661A	Carbon Resistor 22K ERD-14V J
	0B07721A	LA P.C.B.	R111,211	0B05511A	Carbon Resistor 820 ERD-14V J
Q101,102	0B06062A	Transistor 2SC1222 (2)	R112,212	0B05663A	Carbon Resistor 10 ERD-14V J
104,105			R113,213	0B05650A	Carbon Resistor 12K ERD-14V J
201,202			R116,216	0B05935A	Metal Film Resistor 27K ERO-25VK G
204,205			R117,217	0B05934A	Metal Film Resistor 9.1K ERO-25VK G
Q103,109	0B01872A	Transistor 2SC945	R118,218	0B05564A	Carbon Resistor 1M ERD-14V J
110,203			R119,219	0B05591A	Carbon Resistor 15K ERD-14V J
209,210			R121,122	0B05567A	Carbon Resistor 33 ERD-14V J
Q106,107	0B06013A	Transistor 2SA733	221,222		
108,206			R123,223	0B01920A	Carbon Resistor 100K ERD-14V J
207,208			R124,224	0B05562A	Carbon Resistor 47K ERD-14V J
D101,102	0B01909A	Silicon Diode 1S1555	C101,201	0B01863A	Electrolytic Capacitor 3.3μ 16V
103,104			C102,202	0B01404A	Electrolytic Capacitor 47μ 6.3V
105,201			C103,203	0B05744A	Ceramic Capacitor 33P
202,203			C104,108	0B01412A	Electrolytic Capacitor 10μ 16V
204,205			204,208		
R101,201	0B05700A	Carbon Resistor 470K ERD-14V J	C105,106	0B05884A	Electrolytic Capacitor 470μ 10V
R102,202	0B05563A	Carbon Resistor 56K ERD-14V J	C107,207	0B05798A	Ceramic Capacitor 10P
R103,203	0B05608A	Carbon Resistor 220 ERD-14V J	SW1	0B07170A	Push Switch SUE22
R104,115	0B05569A	Carbon Resistor 47 ERD-14V J	CN1	0B08236A	4P-T Post
204,215			CN2	0B08182A	6P-T Post
R105,114	0B05559A	Carbon Resistor 680 ERD-14V J			
205,214					
R106,107	0B05933A	Metal Film Resistor 6.8K ERO-25VK G			
206,207					
R108,109	0B05678A	Carbon Resistor 560 ERD-14V J			
120,208					
209,220					

Mechanism Ass'y and Parts List

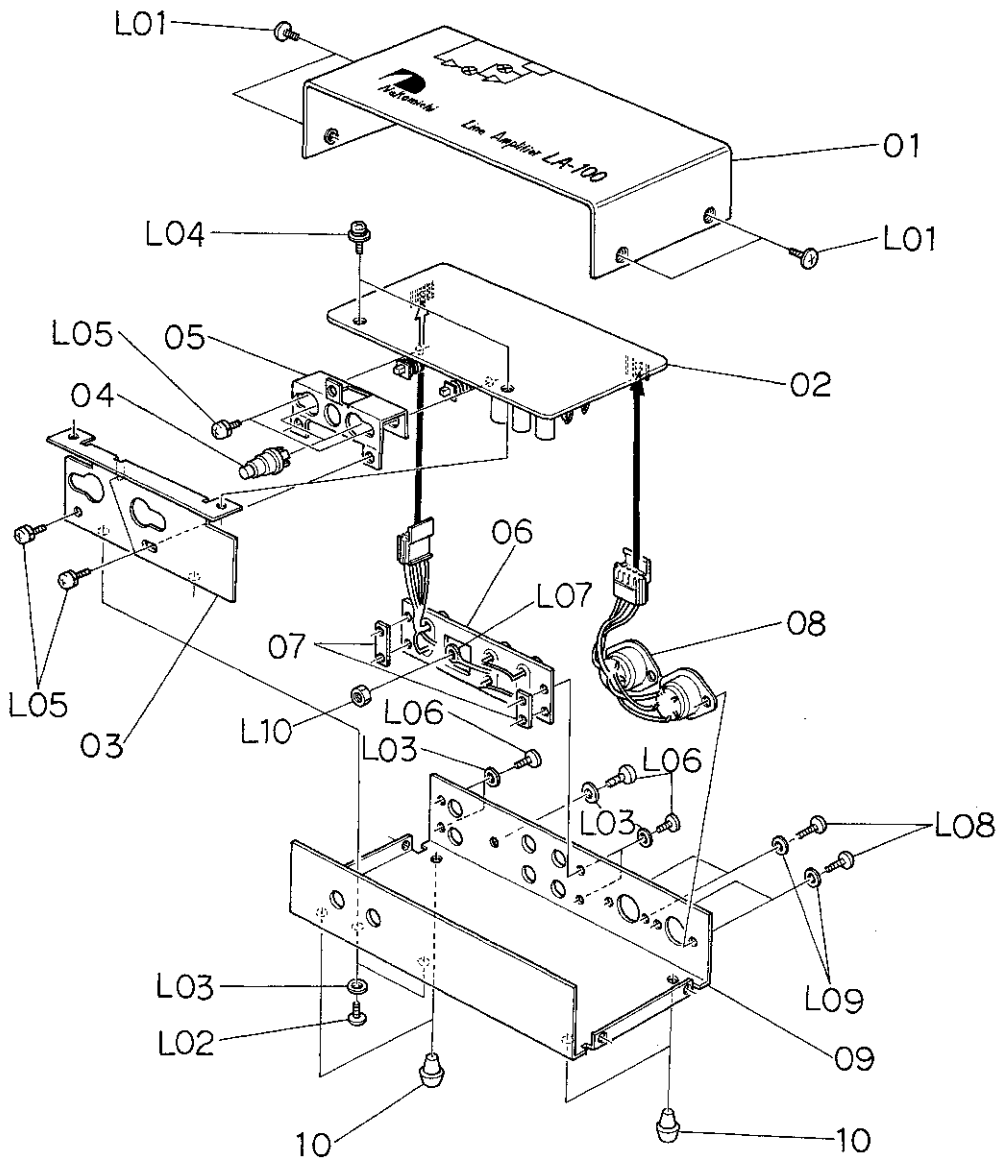

Fig. 3.4

Schematic Ref. No.	Part No.	Description	Q'ty	Schematic Ref. No.	Part No.	Description	Q'ty
		LA-100 Mechanism		L03	0E00157A	Washer 3 mm (plastics)	7
01	0H03518A	Upper Cover LA	1	L04	0E00606A	Screw M3x6 Philips Pan Head (3A)	2
02	BA03859A	LA-100 P.C.B. Ass'y	1	L05	0E00612A	Screw M3x6 Philips Pan Head (2A)	5
03	0J03654B	Front Chassis	1	L06	0E00594A	Screw M3x8 Philips Binding Head	5
04	JA03061A	Push Button Ass'y	2	L07	0E00037A	Earth Lug B-5	1
05	0J03440A	Switch E Block Base	1	L08	0E00714A	Screw M2.6x6 Philips Binding Head	4
06	0B08290B	6P Pin Jack	1	L09	0E00651A	Washer 2.6 mm (plastics)	4
07	0J03277A	Metal Seat Nut	2	L10	0E00507A	Nut Hex. M3	1
08	0B08355A	4P DIN Socket	2				
09	0H03519A	Main Chassis LA	1				
10	0H03437A	Rubber Foot	4				
L01	0E00713A	Screw M3x6 Philips Truss Head	4				
L02	0E00593A	Screw M3x6 Philips Binding Head	2				

4. BA-150 BRIDGING ADAPTOR

General

Except for the exclusion of power supply from BA-150, BA-150 is identical to the BA-100 presently available. Connection of BA-150 across a preamplifier and stereo power amplifiers allows the usage of stereo power amplifiers in monaural use, and delivers the power amplifier output twice the output in the stereophonic configuration. The use of Nakamichi 420 or 620 power amplifier permits the power output increase to 120W or 350W, respectively, and thus the sound quality is expected to be improved.

Transistors Q101 and Q102 in the first stage constitute an emitter follower and a constant current power supply respectively. Q104 and Q105 constitute a differential amplifier, and Q103 and D101 provide a current mirror circuit. Q106 and Q107 constitute a phase inverter and the output of Q107 is a phase-inverted signal of the input; that is, this unit, receives an input signal and outputs it as a non-inverted output and a phase-inverted output, and permits bridging of the left and right outputs of the power amplifiers to form a monaural power amplifier.

Specifications

Maximum Power Consumption 0.5 VA
 Current Consumption 25 mA
 Reference Input Voltage 1 V
 Input Impedance 10 k Ω
 Reference Output Voltage 1 V
 Output Impedance 500 Ω
 Maximum Input Voltage 4 V
 Maximum Output Voltage 4 V
 Phase-symmetry Degree within 1° (5 Hz – 50 kHz)
 Dimensions 7-1/2(W) x 2-3/8(H) x
 3-13/16(D) inches
 190(W) x 60(H) x 97(D) mm
 Weight 2.4 lb, 1.1 kg

System Diagram

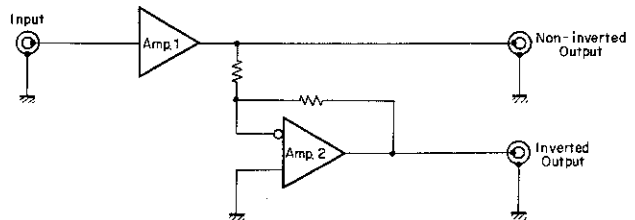

Fig. 4.1

Schematic Diagram

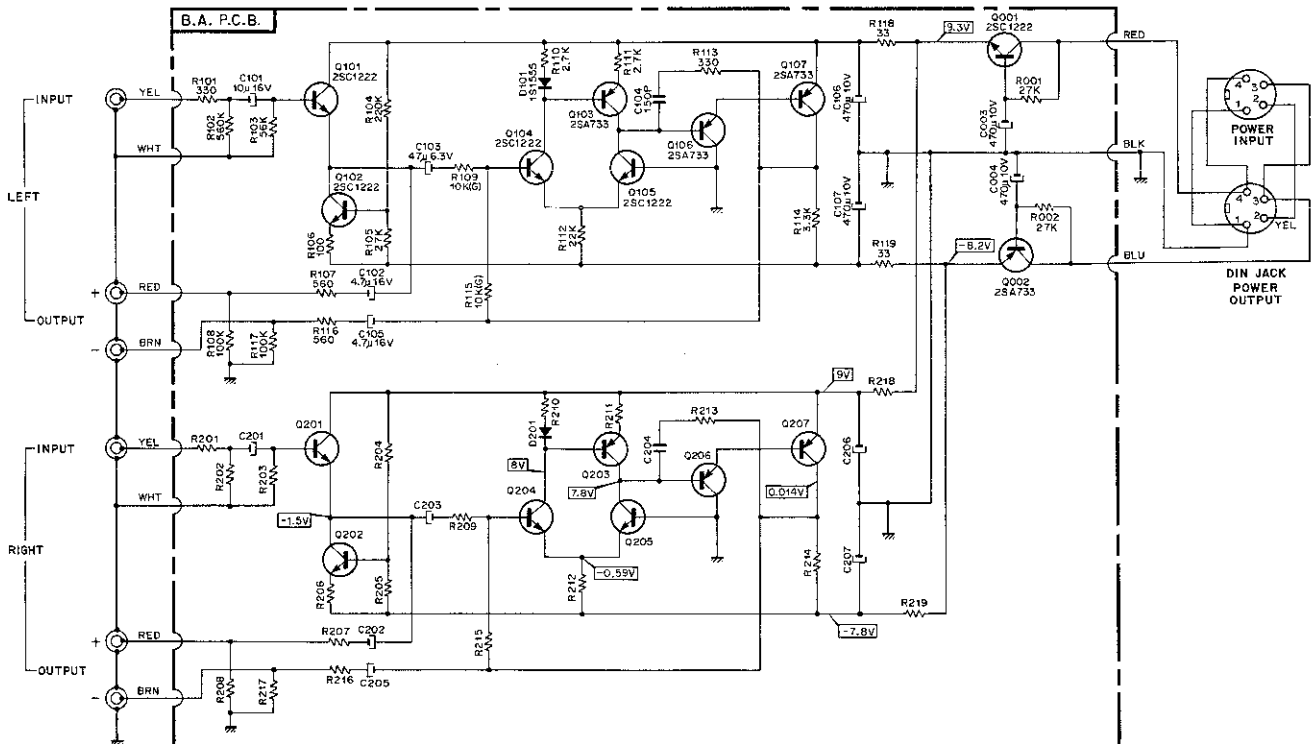

Fig. 4.2

Mounting Diagram and Parts List

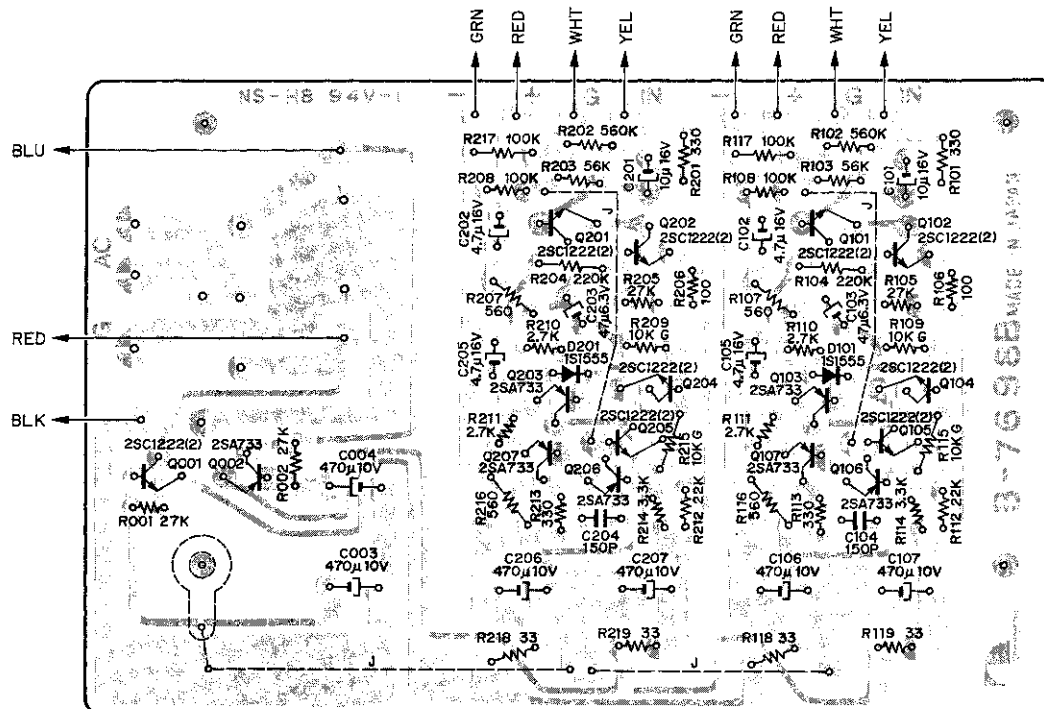

Fig. 4.3

Schematic Ref. No.	Part No.	Description	Schematic Ref. No.	Part No.	Description
	BA03863A	BA-150 P.C.B. Ass'y	R118,119	0B05567A	Carbon Resistor 33 ERD-14V J
	0B07698B	BA P.C.B.	218,219	0B05884A	Electrolytic Capacitor
Q001,101	0B06062A	Transistor 2SC1222 (2)	C003,004		470μ 10V
102,104			106,107		
105,201			206,207	0B01412A	Electrolytic Capacitor
202,204			C101,201		10μ 16V
205			C102,105	0B01389A	Electrolytic Capacitor
Q002,103	0B06013A	Transistor 2SA733	202,205		4.7μ 16V
106,107			C103,203	0B01404A	Electrolytic Capacitor
203,206					47μ 6.3V
207			C104,204	0B05599A	Ceramic Capacitor 150P 50V
D101,201	0B01909A	Silicon Diode 1S1555		0E00037A	Earth Lug B-5 (1 pce.)
R001,002	0B05538A	Carbon Resistor 27K ERD-14V J			
105,205					
R101,113	0B01789A	Carbon Resistor 330 ERD-14V J			
201,213					
R102,202	0B05665A	Carbon Resistor 560K ERD-14V J			
R103,203	0B05563A	Carbon Resistor 56K ERD-14V J			
R104,204	0B05596A	Carbon Resistor 220K ERD-14V J			
R106,206	0B05558A	Carbon Resistor 100 ERD-14V J			
R107,116	0B05678A	Carbon Resistor 560 ERD-14V J			
207,216					
R108,117	0B01920A	Carbon Resistor 100K ERD-14V J			
208,217					
R109,115	0B05895A	Metal Film Resistor 10K ER0-25VK G			
209,215					
R110,111	0B01782A	Carbon Resistor 2.7K ERD-14V J			
210,211					
R112,212	0B05661A	Carbon Resistor 22K ERD-14V J			
R114,214	0B01793A	Carbon Resistor 3.3K ERD-14V J			

Mechanism Ass'y and Parts List

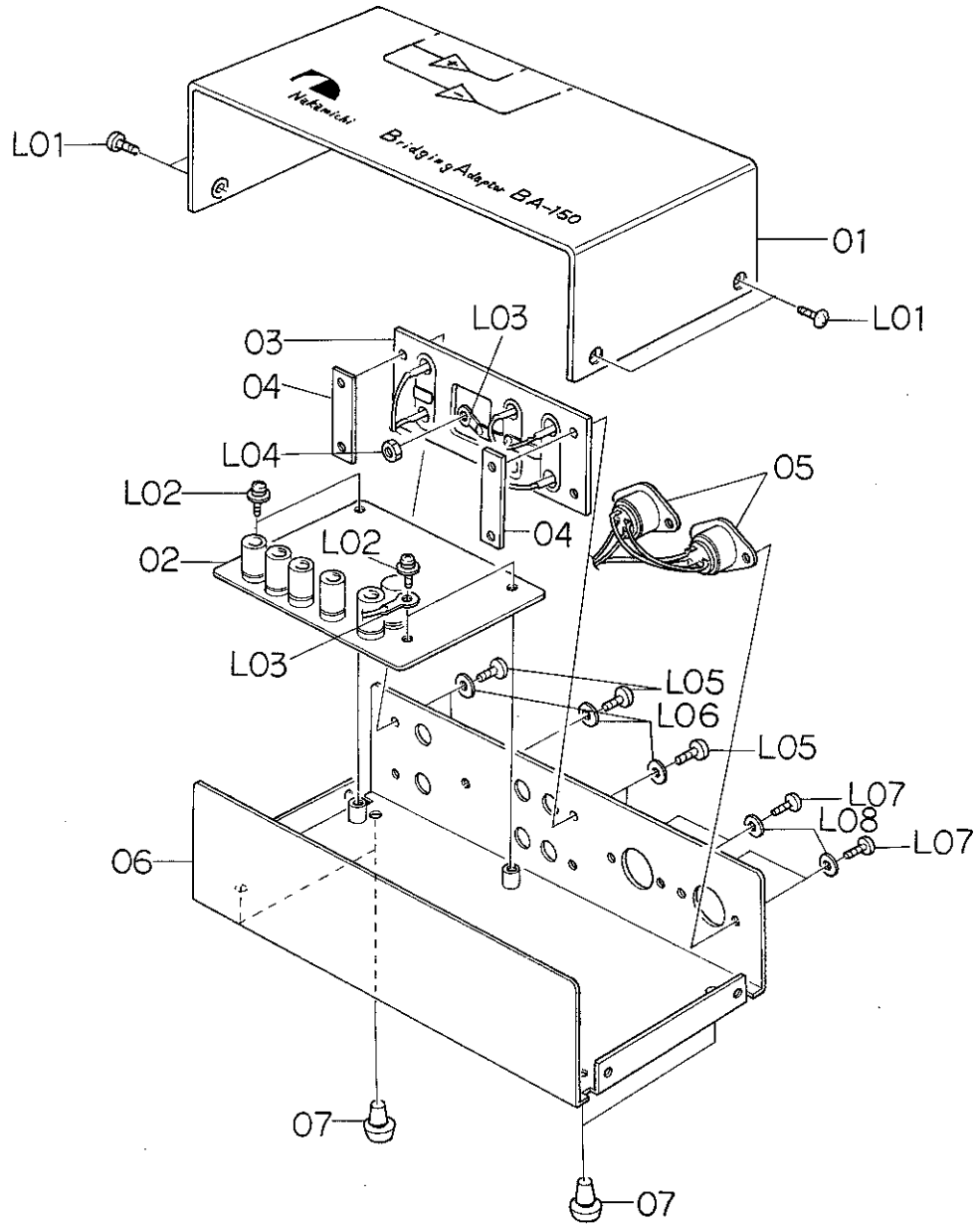

Fig. 4.4

Schematic Ref. No.	Part No.	Description	Q'ty	Schematic Ref. No.	Part No.	Description	Q'ty
		BA-150 Mechanism		L03	0E00037A	Earth Lug B-5	2
				L04	0E00507A	Nut Hex. M3	1
01	0H03523A	Upper Cover BA-150	1	L05	0E00594A	Screw M3x8 Philips Binding Head	5
02	BA03863A	BA-150 P.C.B. Ass'y	1	L06	0E00157A	Washer 3 mm (plastics)	5
03	0B08290B	6P Pin Jack	1	L07	0E00714A	Screw M2.6x6 Philips Binding Head	4
04	0J03277A	Metal Seat Nut	2	L08	0E00651A	Washer 2.6 mm (plastics)	4
05	0B08355A	4P DIN Socket	2				
06	HA03709A	Main Chassis BA Ass'y	1				
07	0H03437A	Rubber Foot	4				
L01	0E00713A	Screw M3x6 Philips Truss Head	4				
L02	0E00606A	Screw M3x6 Philips Pan Head (3A)	4				

5. MB-150 MC BOOSTER AMPLIFIER

General

MB-150 is a booster amplifier used to increase gain for an MC type cartridge at low output level.

The gain can be selected at two levels of 38 dB/22 dB by switching the Gain Switch ON/OFF. With the Pass Switch set to ON, the input from the cartridge is directly delivered as the output without passing through the amplifier.

Complementary circuits used in all stages of MB-150 reduce distortion.

The first stage is composed of 10 PNP transistors and 10 NPN transistors, with low noise figures at small signal source impedance, which are connected in parallel respectively to ensure low noise figures.

The second stage adopts the particular triple transistor configuration as used in the first stage of Nakamichi 610, 410, and 630 Equalizing Amplifiers, and its equivalent input noise figure is less than -158 dB (with RIAA IHF-A Network).

The first-stage transistors have the combination of NPN and PNP. Theoretically, if the characteristics of both types are the same, the collector currents of these transistors are equal, and their base currents are the same if the current amplification h_{FE} 's are equal; therefore d.c. voltage across the input terminals vanishes at the identical values of + and - power supply voltage. In actual circuits, However, a + or - voltage slightly remains due to various factors and the voltage should be adjusted to zero by offset voltage adjustment.

Offset Voltage Adjustment

1. Insert shorted pin plugs into input jacks of MB-150.
2. Connect a PS-100 power supply unit to the MB-150 and turn the power switch of the PS-100 ON.
3. Connect an amplifier to the output jacks and listen to sound with headphones or a speaker.
4. Adjust semi-fixed volumes VR101 and VR201 so that switching noises generated at the ON/OFF operation of the pass switch reduce to a inaudible level.

Specifications

Maximum Power Consumption . . .	2 VA
Current Consumption	100 mA
Total Harmonic Distortion	0.005% (20 Hz - 20 kHz, 0.3 V Output)
Frequency Response	20 Hz - 100 kHz +0, -1 dB (+38 dB Gain) 10 Hz - 100 kHz +0, -0.5 dB (+22 dB Gain)
Equivalent Input Noise	-158 dB (RIAA, IHF-A Network)
Ref. Output Level/Output Impedance	5 mV/5.6 Ω
Ref. Input Level/Input Impedance	0.4 mV/56 Ω (+22 dB Gain) 63 μ V/56 Ω (+38 dB Gain)
Maximum Input Level	200 mV (+22 dB Gain) 30 mV (+38 dB Gain)
Dimensions	7-1/2(W) x 2-3/8(H) x 3-15/16(D) inches 190(W) x 60(H) x 100(D) mm
Weight	2.9 lb, 1.3 kg

System Diagram

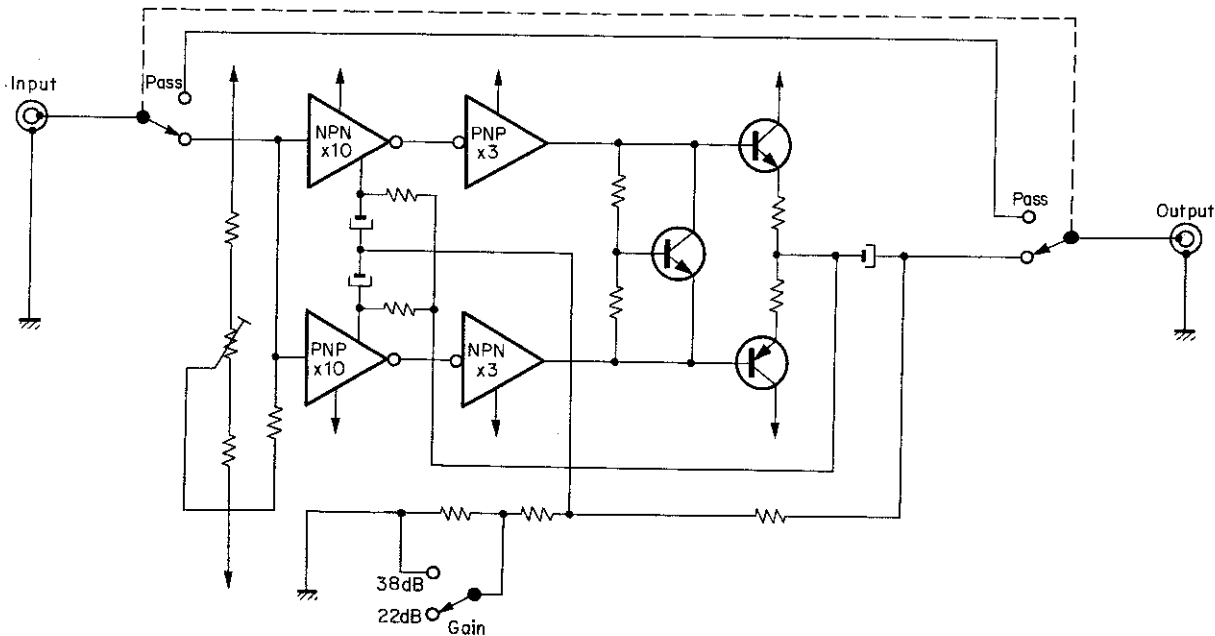

Fig. 5.1

Mechanism Ass'y and Parts List

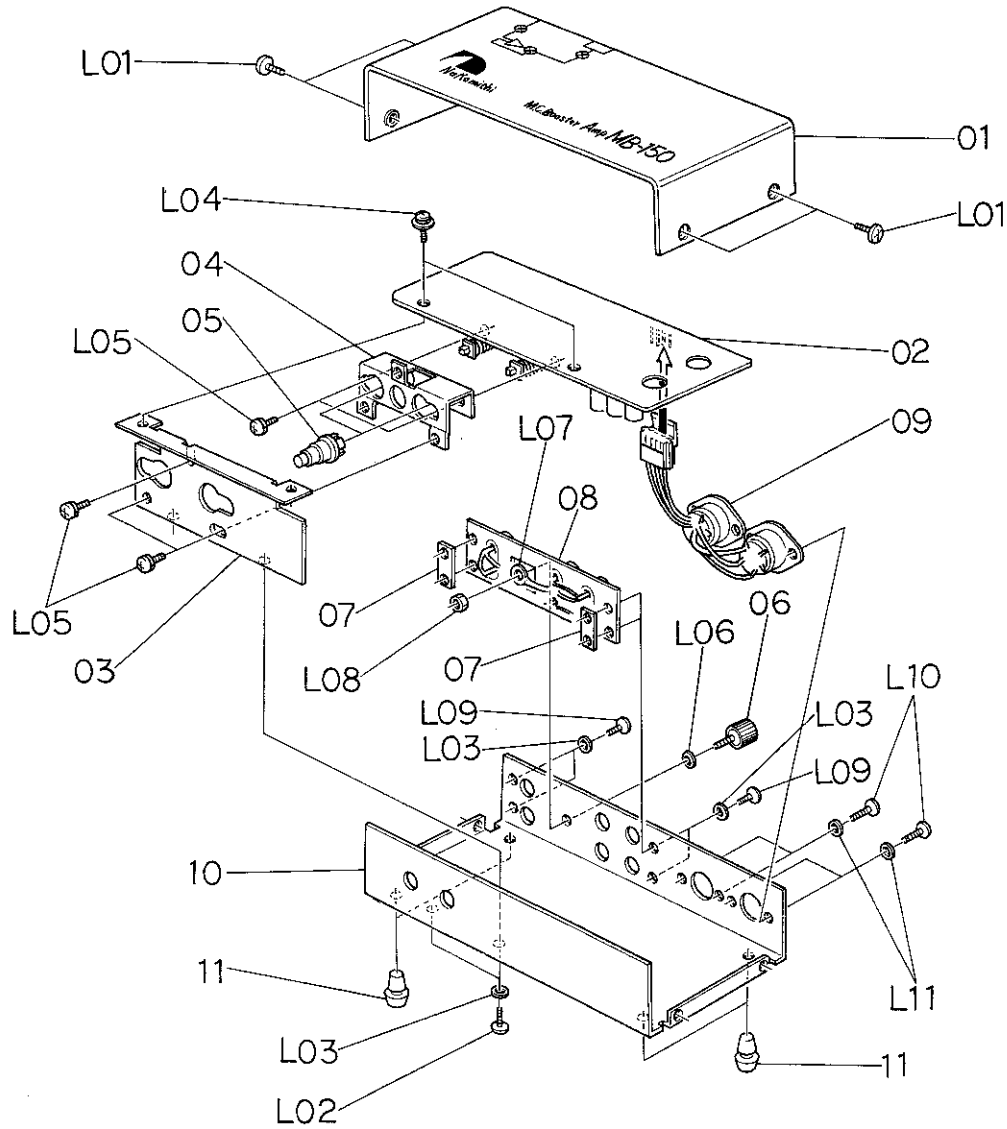

Fig. 5.2

Schematic Ref. No.	Part No.	Description	Q'ty	Schematic Ref. No.	Part No.	Description	Q'ty
		MB-150 Mechanism		L02	0E00593A	Screw M3x6 Philips Binding Head	2
01	0H03521A	Upper Cover MB	1	L03	0E00157A	Washer 3 mm (plastics)	6
02	BA03860A	MB-150 P.C.B. Ass'y	1	L04	0E00606A	Screw M3x6 Philips Pan Head (3A)	2
03	0J03654B	Front Chassis	1	L05	0E00612A	Screw M3x6 Philips Pan Head (2A)	5
04	0J03440A	Switch E Block Base	1	L06	0E00732A	Washer 3 mm	1
05	JA03061A	Push Button Ass'y	2	L07	0E00037A	Earth Lug B-5	1
06	0B03920B	Ground Terminal	1	L08	0E00507A	Nut Hex. M3	1
07	0J03277A	Metal Seat Nut	2	L09	0E00594A	Screw M3x8 Philips Binding Head	4
08	0B08394A	6P Pin Jack	1	L10	0E00714A	Screw M2.6x6 Philips Binding Head	4
09	0B08355A	4P DIN Socket	2	L11	0E00651A	Washer 2.6 mm (plastics)	4
10	0H03522C	Main Chassis MB	1				
11	0H03437A	Rubber Foot	4				
L01	0E00713A	Screw M3x6 Philips Truss Head	4				

Schematic Diagram

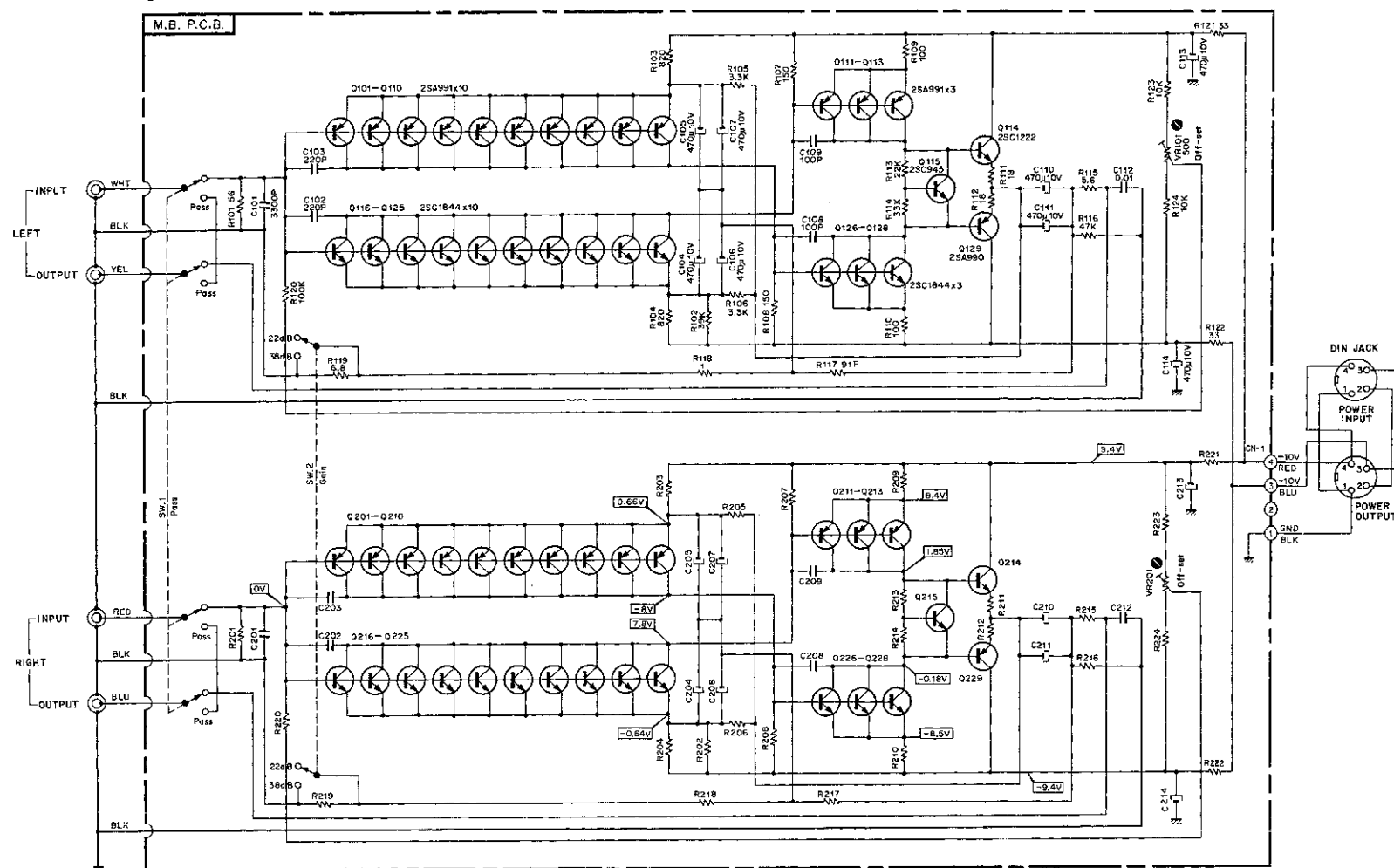

Fig. 5.3

Mounting Diagram and Parts List

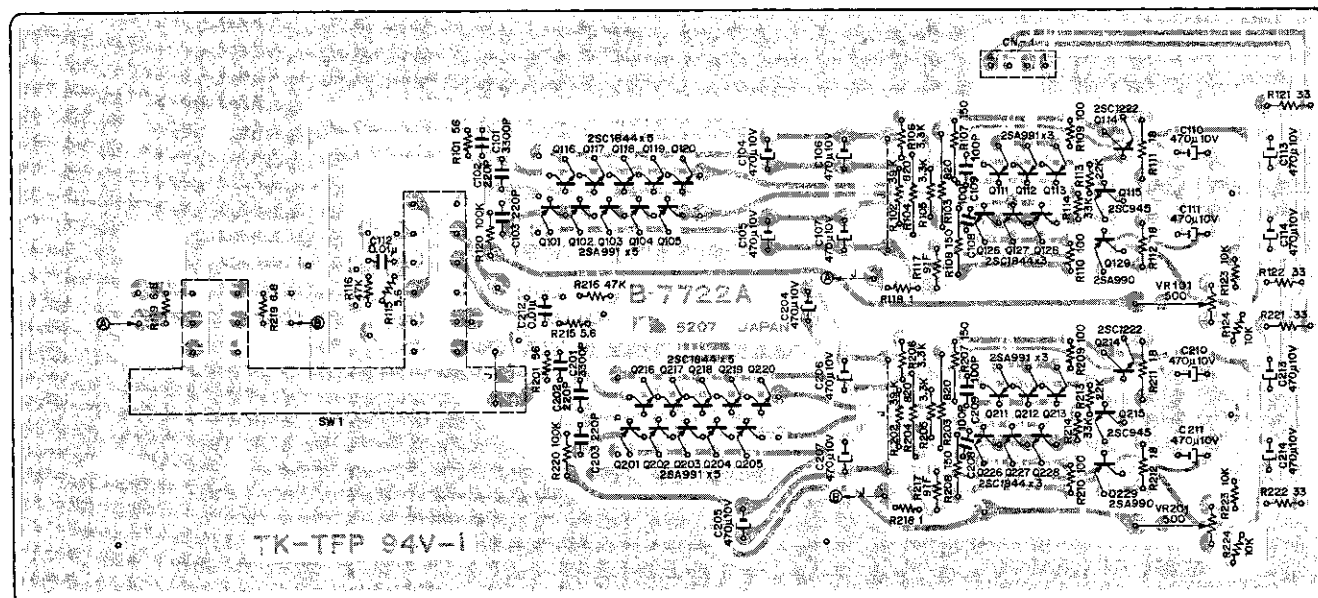

Fig. 5.4

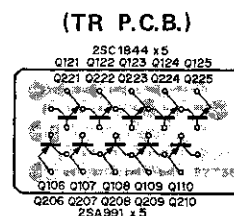

Fig 5.5

Schematic Ref. No.	Part No.	Description
	BA03860A	MB-150 P.C.B. Ass'y
Q101-113	0B07722A	MB P.C.B.
201-213	0B06120A	Transistor 2SA991 (26 pcs.)
Q114,214	0B06062A	Transistor 2SC1222 (2)
Q115,215	0B01872A	Transistor 2SC945
Q116-128	0B06119A	Transistor 2SC1844 (26pcs.)
216-228		
Q129,229	0B06121A	Transistor 2SA990
VR101,201	0B07159A	Semi-fixed Volume 500
R101,201	0B05587A	Carbon Resistor 56 ERD-25V J
R102,202	0B01885A	Carbon Resistor 39K ERD-25V J
R103,104	0B05511A	Carbon Resistor 820 ERD-25V J
203,204		
R105,106	0B01793A	Carbon Resistor 3.3K ERD-25V J
205,206		
R107,108	0B05649A	Carbon Resistor 150 ERD-25V J
207,208		
R109,110	0B05558A	Carbon Resistor 100 ERD-25V J
209,210		
R111,112	0B05545A	Carbon Resistor 18 ERD-25V J
211,212		
R113,213	0B05661A	Carbon Resistor 22K ERD-25V J
R114,214	0B01879A	Carbon Resistor 33K ERD-25V J
R115,215	0B05818A	Carbon Resistor 5.6 ERD-25V J
R116,216	0B05562A	Carbon Resistor 47K ERD-25V J
R117,217	0B05952A	Metal Film Resistor 91 ERO-25VK F
R118,218	0B05746A	Carbon Resistor 1 ERD-25V J
R119,219	0B05854A	Carbon Resistor 6.8 ERD-25V J
R120,220	0B01920A	Carbon Resistor 100K ERD-25V J
R121,122	0B05567A	Carbon Resistor 33 ERD-25V J
221,222		
R123,124	0B01833A	Carbon Resistor 10K ERD-25V J
223,224		
C101,201	0B01914A	Mylar Capacitor 3300P 50V
C102,103	0B01289A	Ceramic Capacitor 220P 50V
202,203		
C104,105	0B05884A	Electrolytic Capacitor
106,107		470μ 10V
110,111		
113,114		
204,205		
206,207		
210,211		
213,214		
C108,109	0B01288A	Ceramic Capacitor
208,209		100P 50V
C112,212	0B01290A	Ceramic Capacitor 0.01μ 50V
SW1	0B07167A	Push Switch SVE
CN1	0B08236A	4P-T Post
	0B08366A	Shield Case MB (2 pcs.)
	0B07738A	TR P.C.B. (2 pcs.)

6. EC-100 ELECTRONIC CROSSOVER

General

EC-100, a combination of a high-pass filter, a phase shifter and an adder, separates an input signal into a high-passed output and a low-passed output.

Each of the two output signals is delivered to a respective power amplifier for driving a 2-way speaker system.

A combination of two or more EC-100's makes it possible to drive a 3-way or 4-way speaker system.

The transfer function $G_H(s)$ of a high pass filter is given by the formula:

$$G_H(s) = \frac{S^2}{(S + \omega_0)^2} \dots\dots\dots 1$$

The transfer function $G_P(s)$ of a phase shifter is expressed as:

$$G_P(s) = -\frac{S - \omega_0}{S + \omega_0} \dots\dots\dots 2$$

Further, the added output (Eq. 1 + Eq. 2) of the adder is:

$$G_H(s) + G_P(s) = \frac{\omega_0^2}{(S + \omega_0)^2} \dots\dots\dots 3$$

The transfer function of Eq. 3 accords with that of a low pass filter circuit. Therefore the output of the adder is a signal of lower frequency range.

The crossover frequency setting of EC-100 at 19 steps from 66 Hz to 7.4 kHz is possible by adjusting the Frequency Control VR001.

The Frequency Control is interlocked at 19 frequency positions in total, including 10 positions marked on the Frequency Control and 9 positions at the middle of them. These frequencies are 66, 68, 78, 95, 120, 170, 250, 320, 370, 440, 530, 660, 880 Hz and 1.4 k, 2.4 k, 3.9 k, 5.4 k, 7 k, and 7.4 kHz. The attenuation characteristic of the filters is 12 dB/oct.

EC-100 has the same characteristics as conventional multi-band filter circuits; however, in the crossover frequency switching system of EC-100 is improved from conventional systems that have to change the resistance and capacitance simultaneously to the system changing only the resistance.

Specifications

Maximum Power Consumption	2 VA
Current Consumption	100 mA
Attenuation	12 dB/oct.
Crossover Frequencies	66, 68, 78, 95, 120, 170, 250, 320, 370, 440, 530, 660, 880 Hz, 1.4 k, 2.4 k, 3.9 k, 5.4 k, 7 k, 7.4 kHz
Distortion	less than 0.005% (20 Hz – 20 kHz)
Signal-to-Noise Ratio	better than 110 dB (IHF-A Network)
Ref. Input Level/Input Impedance	1 V/50 kΩ
Ref. Output Level/Output Impedance	1 V/560 Ω
Maximum Input Level	4 V
Mute Function	Furnished
Dimensions	7-1/2(W) x 2-3/8(H) x 3-15/16(D) inches 190(W) x 60(H) x 100(D)mm
Weight	2.4 lb, 1.1 kg

System Diagram

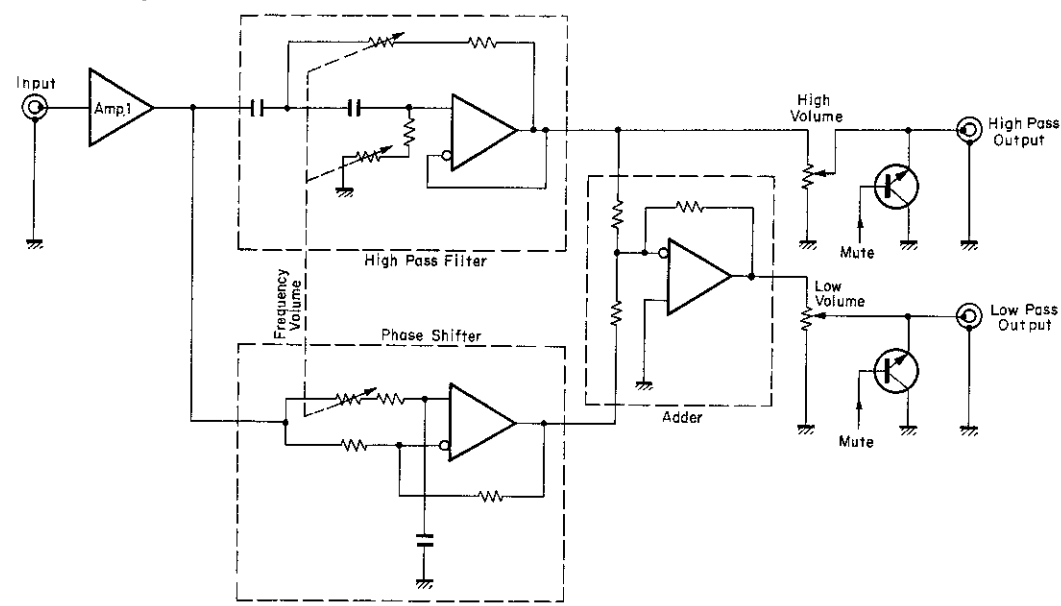

Fig. 6.1

Schematic Diagram

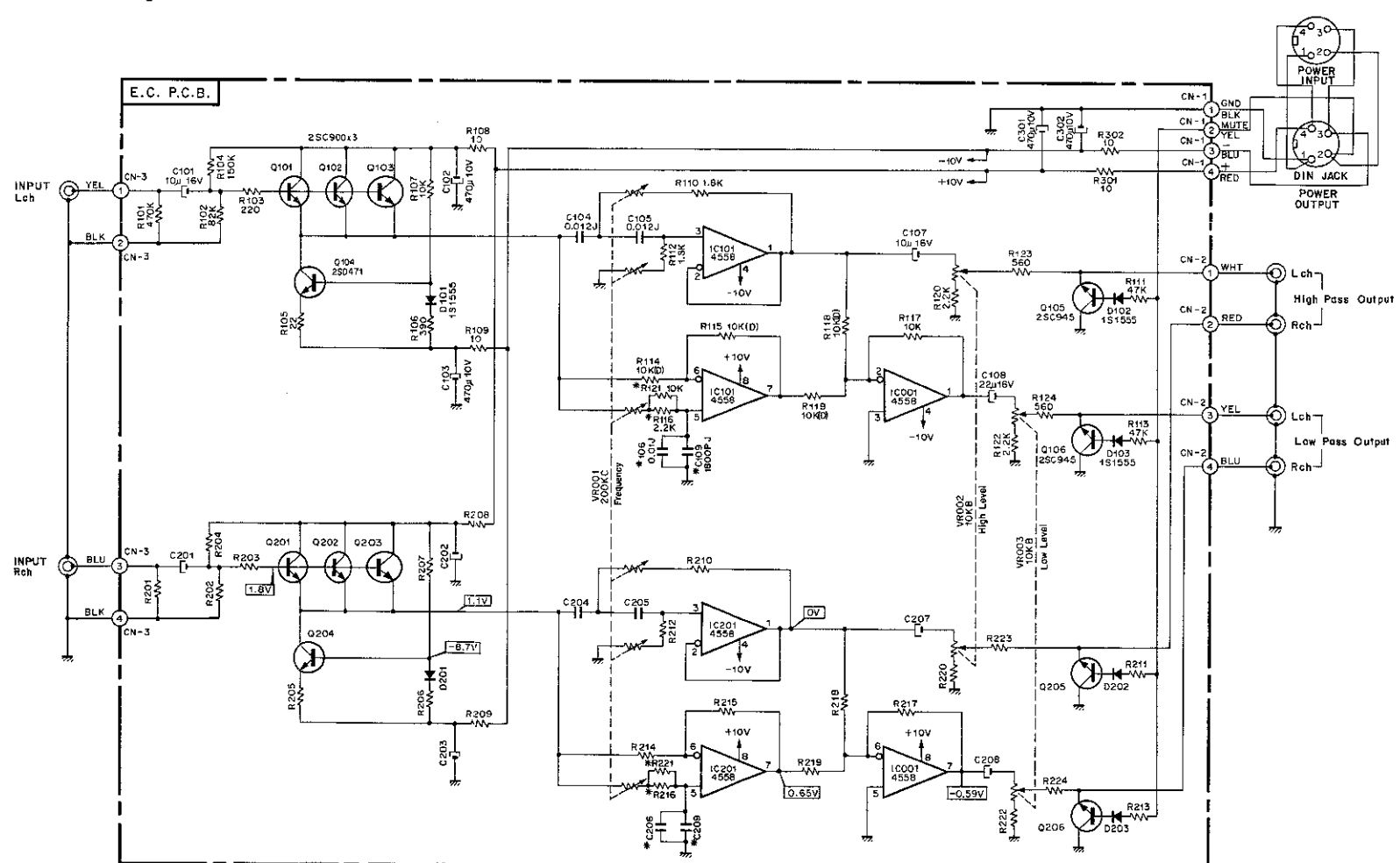

Fig. 6.2

Note:

Resistors and capacitors marked with * will be adjusted in order to achieve accurate crossover frequencies when frequency volume is interlocked at 19 positions.

The standard value of these resistors and capacitors are shown in the figure.

Mounting Diagram and Parts List

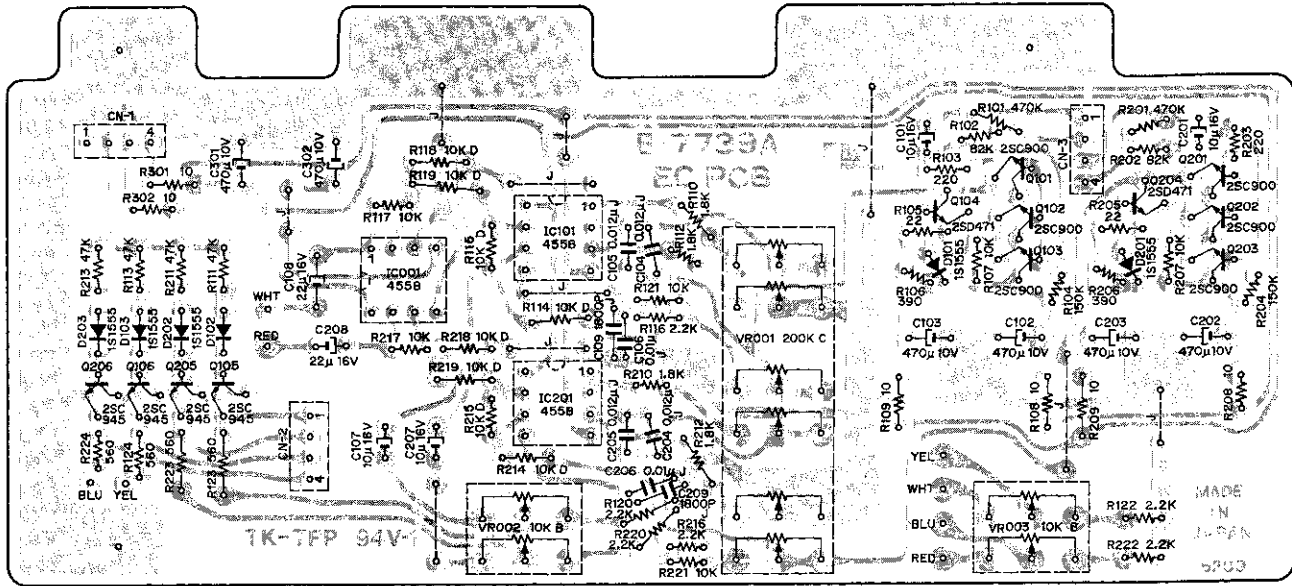

Fig. 6.3

Schematic Ref. No.	Part No.	Description	Schematic Ref. No.	Part No.	Description
	BA03868A	EC-100 P.C.B. Ass'y	R114,115	0B05955A	Metal Film Resistor 10K ER0-25VK D
	0B07739B	EC P.C.B.	118,119		
IC001,101	0B06124A	IC 4558	214,215		
201			218,219		
Q101,102	0B01910A	Transistor 2SC900 (E)	R116,120	0B05566A	Carbon Resistor 2.2K ERD-25V J
103,201			220,222		
202,203			R123,124	0B05678A	Carbon Resistor 560 ERD-25V J
Q104,204	0B06066A	Transistor 2SD471	223,224		
Q105,106	0B01872A	Transistor 2SC945	C101,107	0B01412A	Electrolytic Capacitor 10μ 16V
205,206			201,207		
D101,102	0B01909A	Silicon Diode 1S1555	C102,103	0B05884A	Electrolytic Capacitor 470μ 10V
103,201			202,203		
202,203			301,302		
VR001	0B07182A	Volume 200K (C)	C104,105	0B05843A	Mylar Capacitor 0.012μ J
VR002,003	0B07181A	Volume 10K (B)	204,205		
R101,201	0B05700A	Carbon Resistor 470K ERD-25V J	C106,206	0B05681A	Mylar Capacitor 0.01μ J
R102,202	0B01564A	Carbon Resistor 82K ERD-25V J	C108,208	0B01862A	Electrolytic Capacitor 22μ 16V
R103,203	0B05608A	Carbon Resistor 220 ERD-25V J	C109,209	0B01913A	Mylar Capacitor 1800P J
R104,204	0B05593A	Carbon Resistor 150K ERD-25V J	CN1,2,3	0B08236A	4P-T Post
R105,205	0B05606A	Carbon Resistor 22 ERD-25V J			
R106,206	0B05688A	Carbon Resistor 390 ERD-25V J			
R107,117	0B01833A	Carbon Resistor 10K ERD-25V J			
121,207					
217,221					
R108,109	0B05663A	Carbon Resistor 10 ERD-25V J			
208,209					
301,302					
R110,112	0B01830A	Carbon Resistor 1.8K ERD-25V J			
210,212					
R111,113	0B05641A	Carbon Resistor 47K ERD-25V J			
211,213					

Mechanism Ass'y and Parts List

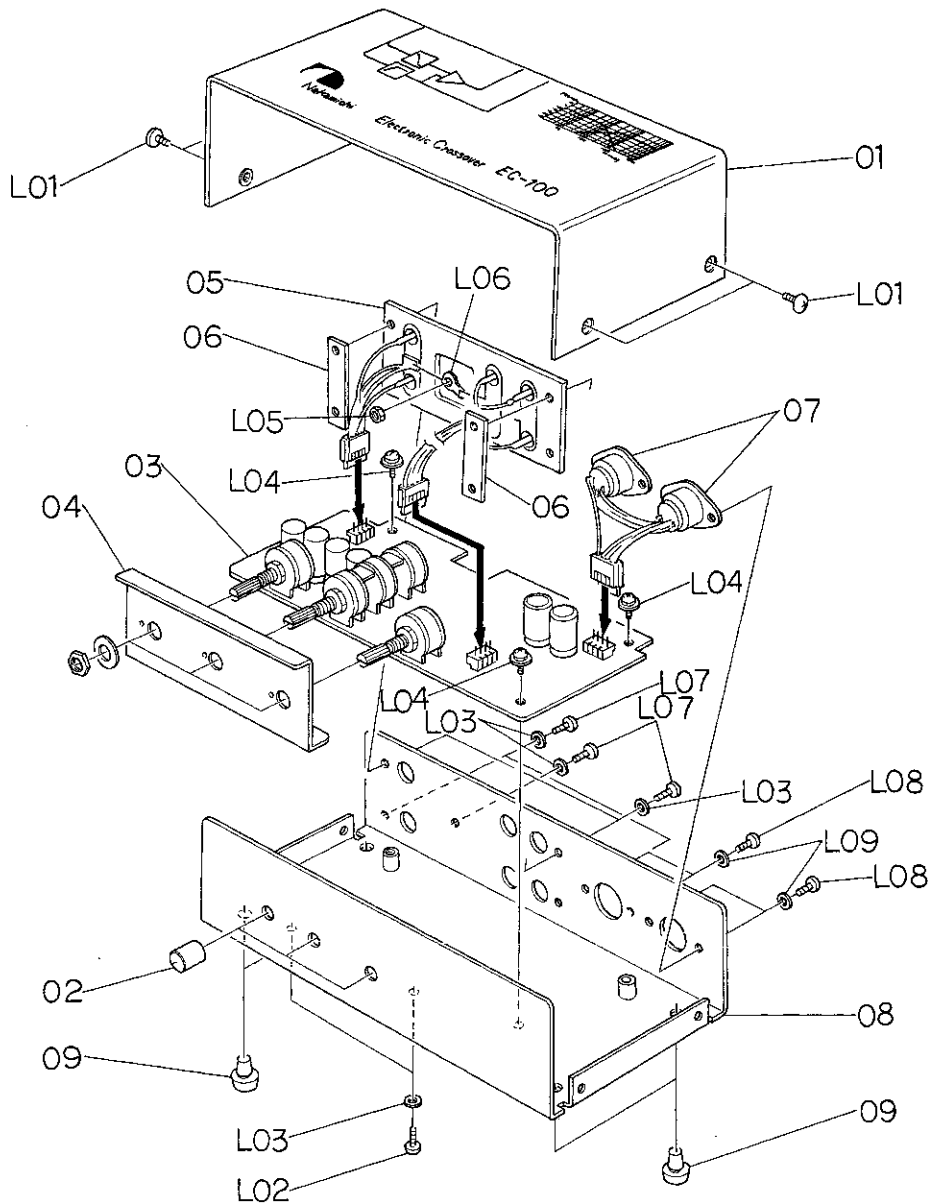

Fig. 6.4

Schematic Ref. No.	Part No.	Description	Q'ty	Schematic Ref. No.	Part No.	Description	Q'ty
		EC-100 Mechanism		L02	0E00593A	Screw M3x6 Philips Binding Head	2
01	0H03528A	Upper Cover EC	1	L03	0E00157A	Washer 3 mm (plastics)	7
02	HA03714A	VR Knob Ass'y	3	L04	0E00606A	Screw M3x6 Philips Pan Head (3A)	3
03	BA03868A	EC-100 P.C.B. Ass'y	1	L05	0E00507A	Nut Hex. M3	1
04	0J03689B	VR Holder MX	1	L06	0E00037A	Earth Lug B-5	1
05	0B08290B	6P Pin Jack	1	L07	0E00594A	Screw M3x8 Philips Binding Head	5
06	0J03277A	Metal Seat Nut	2	L08	0E00714A	Screw M2.6x6 Philips Binding Head	4
07	0B08355A	4P DIN Socket	2	L09	0E00651A	Washer 2.6 mm (plastics)	4
08	HA03713A	Main Chassis EC Ass'y	1				
09	0H03437A	Rubber Foot	4				
L01	0E00713A	Screw M3x6 Philips Truss Head	4				

7. MX-100 MICROPHONE MIXER

General

MX-100 is a mixing unit having three microphone inputs for L-channel, R-channel, and Blend. In addition to the use as a simple microphone mixer connected to line input terminals on a tape deck, the unit allows the application to a PA (public address) amplifier directly connected to an Aux. input of a preamplifier, etc.

Further, connection of this unit to Nakamichi 600 (a cassette console) makes microphone recording by Nakamichi 600 possible.

In addition, connection to the line input of a cassette system, such as Nakamichi 700II, 1000II or 500, allows recording using six microphones.

In Fig.7.1, the gain of the L-channel microphone amplifier is given by the formula:

$$Av(L) = \frac{Ry_1}{R_1 + Rx_1 + Ry_1} \dots\dots\dots 1$$

and the gain of blend microphone amplifier:

$$Av(B) = \frac{Ry_2}{R_2 + Rx_2 + Ry_2} \dots\dots\dots 2$$

The gains of the mixing amplifier:

$$Av(ML) = R_5/R_3 \text{ (for L-channel mic. amp. output),}$$

$$Av(MB) = R_5/R_4 \text{ (for Blend mic. amp. output).}$$

Therefore the output of the L-channel is expressed as:

$$Av(LO) = Av(L) \frac{R_5}{R_3} + Av(B) \frac{R_5}{R_4}$$

Similar to the L-channel, the signal of blend microphone is mixed in the R-channel.

Specifications

Maximum Power Consumption . . .	1 VA
Current Consumption	50 mA
Total Harmonic Distortion	0.05% (10 kHz, 1 V Output, 1 V Input)
Input Sensitivity	0.2 mV
Input Impedance	10 kΩ
Output Level/Output Impedance . .	100 mV/560 Ω
Maximum Input Level	1 V (+ 74 dB)
Mute Function	Furnished
Dimensions	7-1/2(W) x 3-3/8(H) x 4-5/16(D) inches
	190(W) x 60(H) x 110(D)mm
Weight	2.7 lb, 1.2 kg

System Diagram

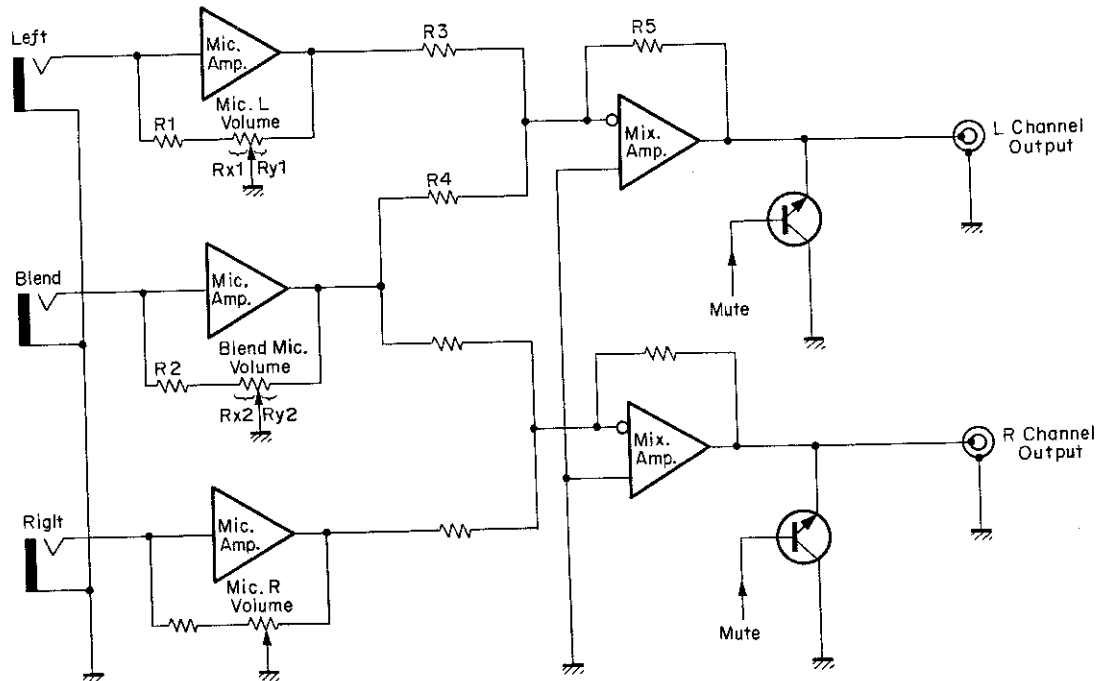

Fig. 7.1

Schematic Diagram

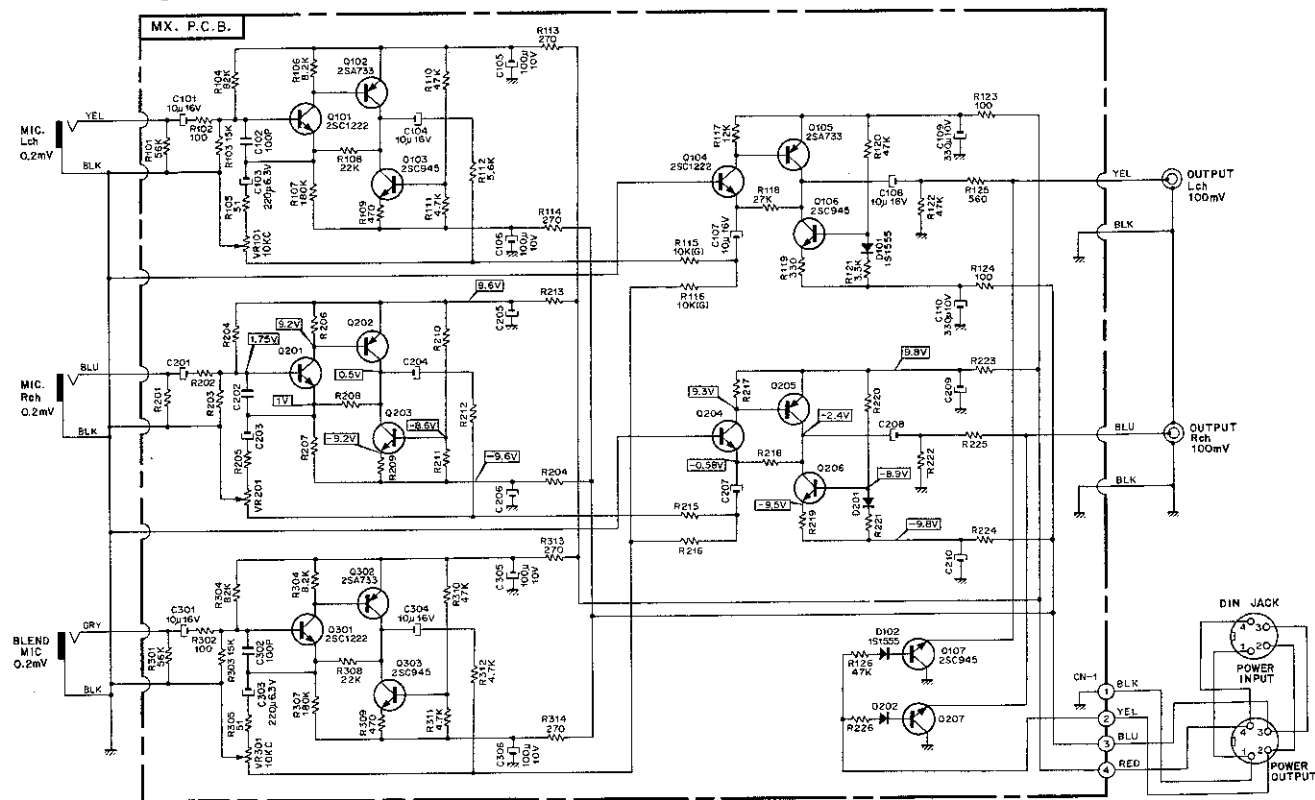

Fig. 7.2

Mounting Diagram and Parts List

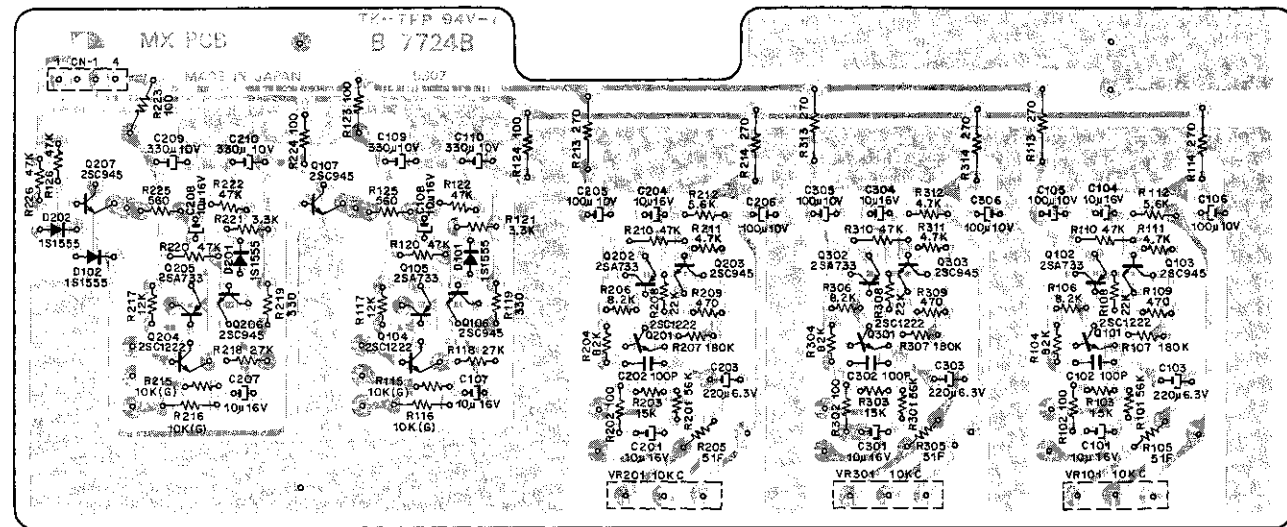

Fig. 7.3

Schematic Ref. No.	Part No.	Description	Schematic Ref. No.	Part No.	Description
	BA03866A	MX-100 P.C.B. Ass'y	R109,209	OB01792A	Carbon Resistor 470 ERD-14V J
	OB07724A	MX P.C.B.	309		
Q101,104	OB06062A	Transistor 2SC1222 (2)	R110,120	OB05562A	Carbon Resistor 47K ERD-14V J
201,204			122,126		
301			210,220		
Q102,105	OB06013A	Transistor 2SA733	222,226		
202,205			310	OB01795A	Carbon Resistor 4.7K ERD-14V J
302			R111,211		
Q103,106	OB01872A	Transistor 2SC945	311,312		
107,203			R112,212	OB05673A	Carbon Resistor 5.6K ERD-14V J
206,207			R113,114	OB05645A	Carbon Resistor 270 ERD-14T J
303			213,214		
D101,102	OB01909A	Silicon Diode 1S1555	313,314		
201,202			R115,116	OB05895A	Metal Film Resistor 10K ERO-25VK G
VR101,201	OB07175A	Volume 10K (C)	215,216		
301			R117,217	OB05650A	Carbon Resistor 12K ERD-14V J
R101,201	OB05563A	Carbon Resistor 56K ERD-14V J	R118,218	OB05538A	Carbon Resistor 27K ERD-14V J
301			R119,219	OB01789A	Carbon Resistor 330 ERD-14V J
R102,123	OB05558A	Carbon Resistor 100 ERD-14V J	R121,221	OB01793A	Carbon Resistor 3.3K ERD-14V J
124,202			R125,225	OB05678A	Carbon Resistor 560 ERD-14V J
223,224			C101,104	OB01412A	Electrolytic Capacitor
302			107,108		10μ 16V
R103,203	OB05591A	Carbon Resistor 15K ERD-14V J	201,204		
303			207,208		
R104,204	OB01564A	Carbon Resistor 82K ERD-14V J	301,304	OB01288A	Ceramic Capacitor 100P
304			C102,202		
R105,205	OB05847A	Metal Film Resistor 51 ERO-25VK F	C103,203	OB01394A	Electrolytic Capacitor
305			303		220μ 6.3V
R106,206	OB01878A	Carbon Resistor 8.2K ERD-14V J	C105,106	OB05885A	Electrolytic Capacitor
306			205,206		100μ 10V
R107,207	OB05669A	Carbon Resistor 180K ERD-14V J	305,306		
307			C109,110	OB05841A	Electrolytic Capacitor
R108,208	OB05661A	Carbon Resistor 22K ERD-14V J	209,210		330μ 10V
308			CN1	OB08236A	4P-T Post

Mechanism Ass'y and Parts List

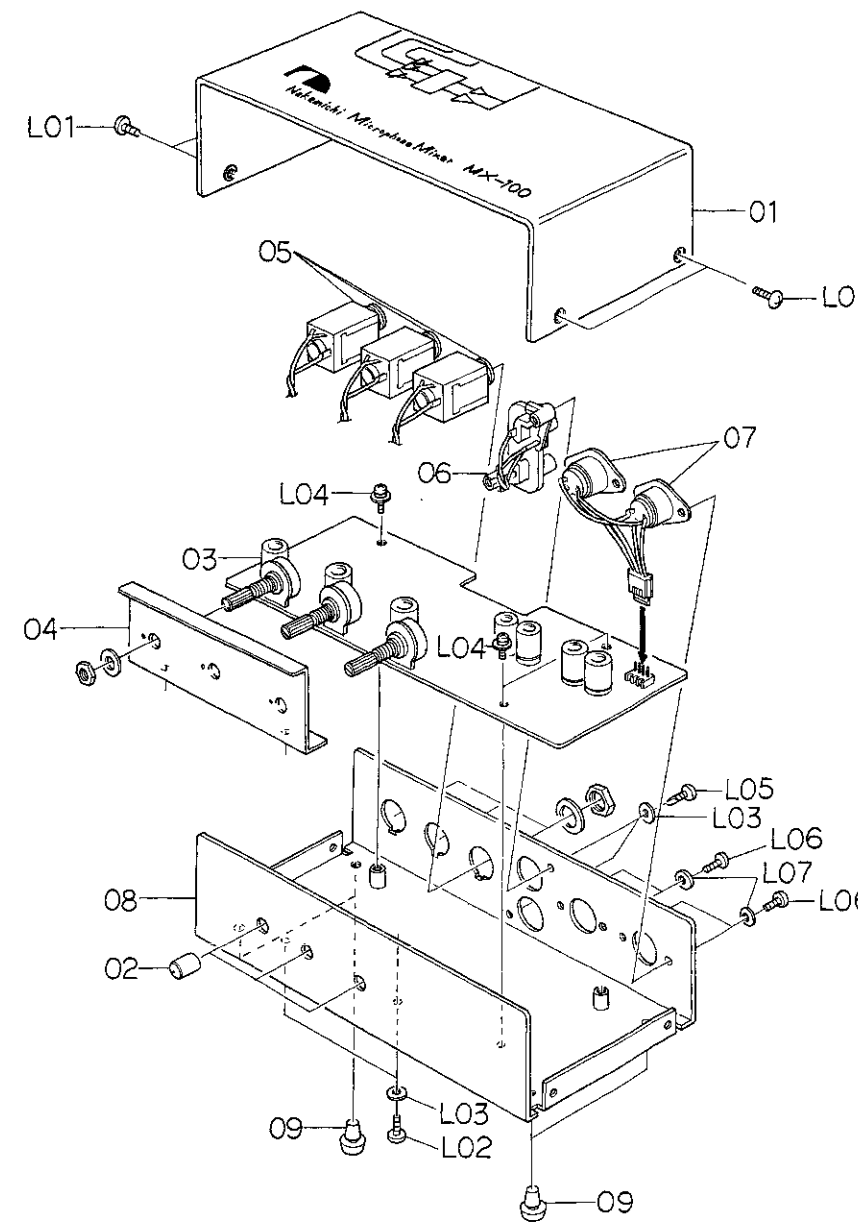

Fig. 7.4

Schematic Ref. No.	Part No.	Description	Q'ty	Schematic Ref. No.	Part No.	Description	Q'ty
		MX-100 Mechanism		L02	0E00593A	Screw M3x6 Philips Binding Head	2
01	0H03526A	Upper Cover MX	1	L03	0E00157A	Washer 3 mm (plastics)	4
02	HA03714A	VR Knob Ass'y	3	L04	0E00606A	Screw M3x6 Philips Pan Head (3A)	3
03	BA03866A	MX-100 P.C.B. Ass'y	1	L05	0E00786A	Screw M3x8 Philips Binding Head TP	2
04	0J03689B	VR Holder MX	1	L06	0E00714A	Screw M2.6x6 Philips Binding Head	4
05	0B03882A	Headphone Jack	3	L07	0E00651A	Washer 2.6 mm (plastics)	4
06	0B08362A	2P Pin Jack	1				
07	0B08355A	4P DIN Socket	2				
08	HA03711A	Main Chassis MX Ass'y	1				
09	0H03437A	Rubber Foot	4				
L01	0E00713A	Screw M3x6 Philips Truss Head	4				