



Service Manual

Nakamichi 1000ZXL

Computing Cassette Deck

Limited

CONTENTS

1. Mounting Diagrams and Parts List	3
1. 1. Fuse P.C.B. Ass'y	3
1. 2. Power Supply P.C.B. Ass'y	5
1. 3. Pin Jack P.C.B. Ass'y	6
1. 4. MIC Jack P.C.B. Ass'y	6
1. 5. RAMM Control Switch P.C.B. Ass'y	6
1. 6. Function Switch P.C.B. Ass'y	7
1. 7. Mechanism Control Switch P.C.B. Ass'y	7
1. 8. Speed Cal. P.C.B. Ass'y	7
1. 9. Counter Pulse Generator P.C.B. Ass'y	7
1. 10. Shut-off P.C.B. Ass'y	7
1. 11. FL Indicator P.C.B. A Ass'y	8
1. 12. FL Indicator P.C.B. B Ass'y	9
1. 13. Detector P.C.B. Ass'y	10
1. 14. Record Dolby NR P.C.B. Ass'y	11
1. 15. Record Eq. Amp. P.C.B. Ass'y	12
1. 16. MIC Amp. and Volume P.C.B. Ass'y	13
1. 17. Playback Amp. and Dolby NR P.C.B. Ass'y	14
1. 18. Main P.C.B. Ass'y	15
1. 19. Logic P.C.B. Ass'y	18
1. 20. CPU P.C.B. A Ass'y	19
1. 21. CPU P.C.B. B Ass'y	22
1. 22. RAMM P.C.B. Ass'y	23
1. 23. Display P.C.B. Ass'y	25
2. Mechanism Ass'y and Parts List	26
2. 1. Synthesis	26
2. 2. Synthesis Mechanism Ass'y (A01)	26
2. 3. Cabinet Ass'y (A02)	27
2. 4. Front Panel Ass'y (B01)	27
2. 5. FL Indicator Ass'y (B02)	28
2. 6. Synthesis Mechanism Sub Ass'y (B03)	28
2. 7. Rear Panel Ass'y (B04)	29
2. 8. Headphone Jack Ass'y (C01)	29
2. 9. Display House Ass'y (C02)	29
2. 10. Front Escutcheon B Ass'y (C03)	29
2. 11. Front Escutcheon A Ass'y (C04)	30
2. 12. Mechanism Ass'y 1000ZXL LTD (D01)	31
2. 13. Chassis Sub Ass'y (D02)	31
2. 14. Flywheel Holder Ass'y (E01)	31
2. 15. Sub Mechanism Chassis Ass'y (E02)	32
2. 16. Main Mechanism Chassis Ass'y (E03)	34
2. 17. Capstan Motor Ass'y (F01)	35
2. 18. Reel Motor Ass'y (G01)	35
2. 19. Control Motor Ass'y (G02)	35
2. 20. Azimuth Alignment Motor Ass'y (G03)	35
2. 21. Head Mount Base Ass'y (H01)	35
2. 22. Supply Pressure Roller Ass'y (H02)	35
2. 23. Take-up Pressure Roller Ass'y (H03)	35
2. 24. Head Base Ass'y E (H04)	36
2. 25. Cassette Case Holder L Ass'y (H05)	36
2. 26. Cassette Case Holder R Ass'y (H06)	36
2. 27. Auto Shut-off Ass'y (H07)	36
2. 28. Pneumatic Damper Ass'y (H08)	36
2. 29. Azimuth Motor Ass'y (I01)	36
2. 30. P-8L Playback Head Ass'y (J01)	37
2. 31. R-8L Record Head Ass'y (J02)	37

3. Wiring Diagram	37
4. Schematic Diagrams	38
4. 1. Attention to Servicemen	38
4. 2. Amplifier Section	39
4. 3. CPU Section	40
4. 4. Mechanism Control Section	41
5. Specifications	42

1.2. Power Supply P.C.B. Ass'y

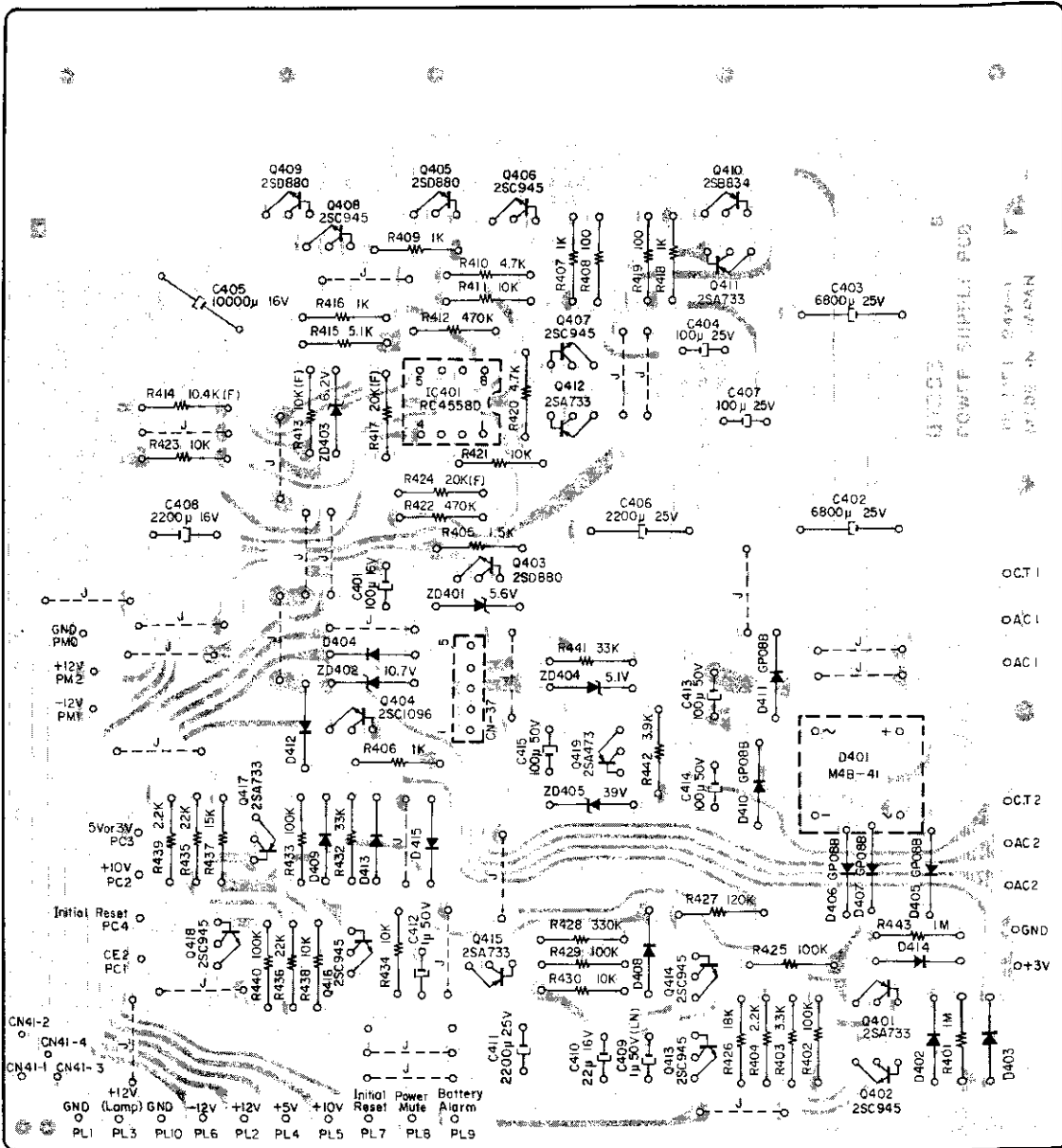

Fig. 1.2

Note: Diode is 1SS53 unless otherwise specified.

Schematic Ref. No.	Part No.	Description	Schematic Ref. No.	Part No.	Description
	BAL4234A	Power Supply P.C.B. Ass'y	C410	OB01862A	Electrolytic Capacitor 22 μ 16V
	OB07885B	Power Supply P.C.B.	C412	OB01405A	Electrolytic Capacitor 1 μ 50V
IC401	OB06124B	IC RC4558D	C413,414	OB09313A	Electrolytic Capacitor 100 μ 50V
Q401,411	OB06013A	Transistor 2SA733	415		
412,415			CN37	OBL8724A	5P-T Post
417			CN41	OBL8743A	4P-H Connector 700mm
Q402,406	OB06100A	Transistor 2SC945 (A)		BA04242A	Pin Jack P.C.B. Ass'y
407,408			FC1	OB07889A	Pin Jack P.C.B.
413,414				OB05247A	9P Flat Cable 140mm
416,418				OB08726A	Pin Jack Unit UA-1047 (3 pcs.)
Q403,405	OB06255A	Transistor 2SD880 (Y)		BAL4243A	MIC Jack P.C.B. Ass'y
409				OB07890A	MIC Jack P.C.B.
Q404	OB06020A	Transistor 2SC1096	CN10,11	OB07890A	MIC Jack P.C.B.
Q410	OB06256A	Transistor 2SB834 (Y)	12	OBL8654A	4P-T Post
Q419	OB06060A	Transistor 2SA473 (Y)		OBL8725A	MIC Jack HLJ0259-01-010 (3 pcs.)
ZD401	OB06268A	Zener Diode 5.6V RD5.6EB3		BAL4241A	RAMM Control Switch P.C.B. Ass'y
ZD402	OB06231A	Zener Diode 10.7V RD11EB3		OB07888A	RAMM Control Switch P.C.B.
ZD403	OB06167A	Zener Diode 6.2V RD6.2EB3		OB07254A	Push Switch EVQ-PXR04K (6 pcs.)
ZD404	OB06230A	Zener Diode 5.1V RD5.1EB3		OBL8752A	8P-H Connector 380mm
ZD405	OB06235A	Zener Diode 39V RD39EB3			
D401	OB06267A	Diode Bridge M4B-41			
D402,403	OB06181A	Silicon Diode 1SS53 (9 pcs.)	SW901-906		
404,408			CN24		
409					
412-415					
D405,406	OB06109A	Silicon Diode GP08B			
407,410					
411					
R401,443	OB05776A	Carbon Resistor 1M ERD-25T J			
R402,425	OB01889A	Carbon Resistor 100K ERD-25T J			
429,433					
440					
R403	OB01681A	Carbon Resistor 3.3K ERD-25T J			
R404,439	OB05622A	Carbon Resistor 2.2K ERD-25T J			
R405	OB05698A	Carbon Resistor 1.5K ERD-25T J			
R406,407	OB01857A	Carbon Resistor 1K ERD-25T J			
409,416					
418					
R408,419	OB01679A	Carbon Resistor 100 ERD-25T J			
R410,420	OB01846A	Carbon Resistor 4.7K ERD-25T J			
R411,421	OB01888A	Carbon Resistor 10K ERD-25T J			
423,430					
434,438					
R412,422	OB01684A	Carbon Resistor 470K ERD-25T J			
R413	OB09203A	Metal Film Resistor 10K SN14K2E F			
R414	OB09433A	Metal Film Resistor 10.4K SN14K2E F			
R415	OB09314A	Carbon Resistor 5.1K ERD-25T J			
R417,424	OB09439A	Metal Film Resistor 20K SN14K2E F			
R426	OB05560A	Carbon Resistor 18K ERD-25T J			
R427	OB05621A	Carbon Resistor 120K ERD-25T J			
R428	OB05627A	Carbon Resistor 330K ERD-25T J			
R432,441	OB05509A	Carbon Resistor 33K ERD-25T J			
R435,436	OB05615A	Carbon Resistor 22K ERD-25T J			
R437	OB01683A	Carbon Resistor 15K ERD-25T J			
R442	OB05675A	Carbon Resistor 3.9K ERD-25T J			
C401	OB01400A	Electrolytic Capacitor 100 μ 16V			
C402,403	OB09374A	Electrolytic Capacitor 6800 μ 25V			
C404,407	OB01272A	Electrolytic Capacitor 100 μ 25V			
C405	OB09487A	Electrolytic Capacitor 10000 μ 16V			
C406,411	OB05654A	Electrolytic Capacitor 2200 μ 25V			
C408	OB01406A	Electrolytic Capacitor 2200 μ 16V			
C409	OB09223A	Electrolytic Capacitor 1 μ 50V (LN)			

1.3. Pin Jack P.C.B. Ass'y

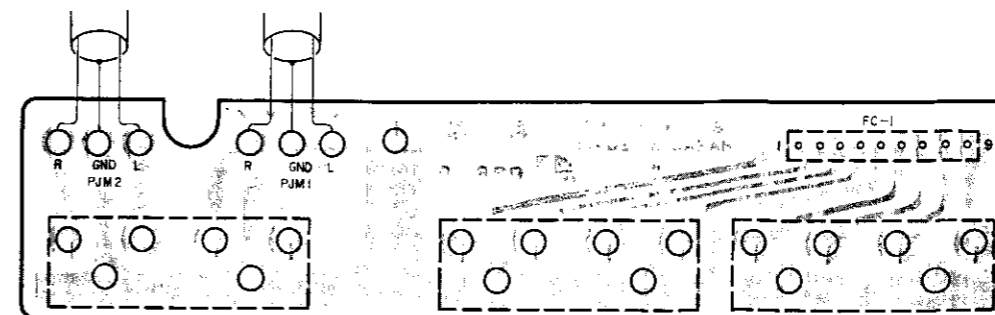

Fig. 1.3

1.4. MIC Jack P.C.B. Ass'y

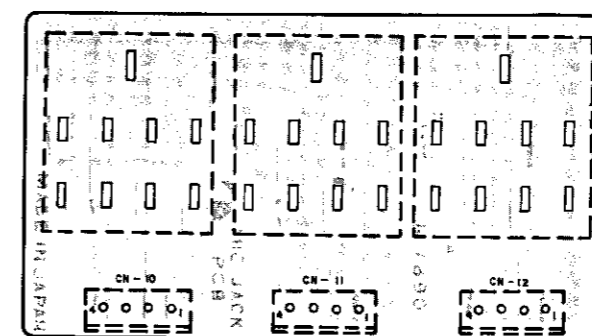

Fig. 1.4

1.5. RAMM Control Switch P.C.B. Ass'y

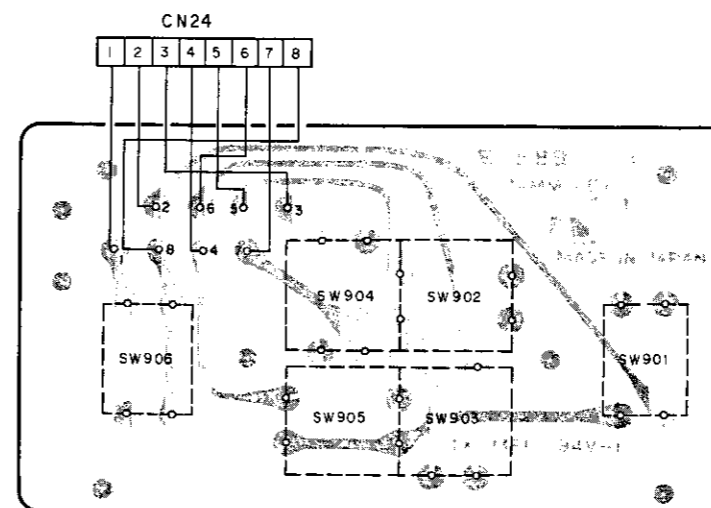

Fig. 1.5

1.6. Function Switch P.C.B. Ass'y

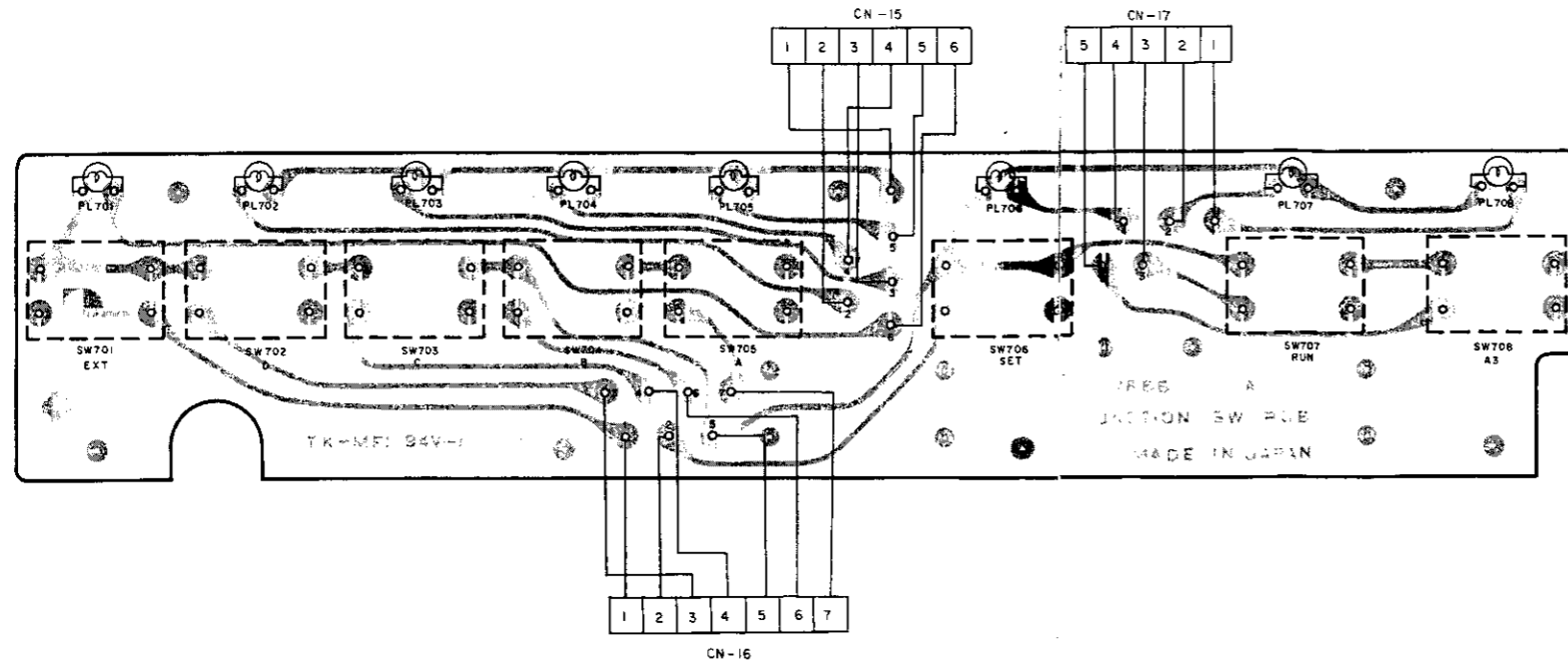

Fig. 1.6

1.7. Mechanism Control Switch P.C.B. Ass'y

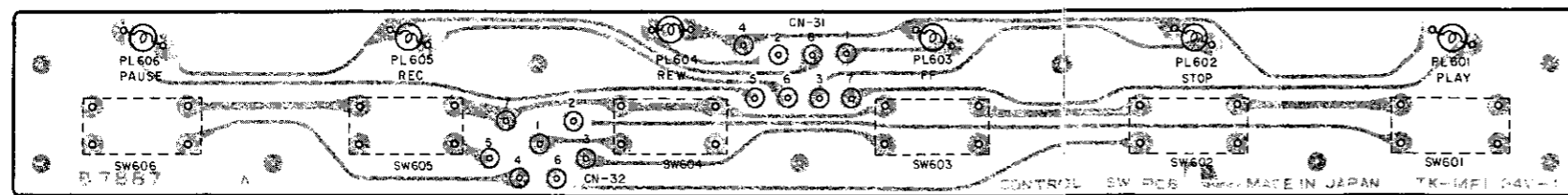

Fig. 1.7

1.8. Speed Cal. P.C.B. Ass'y

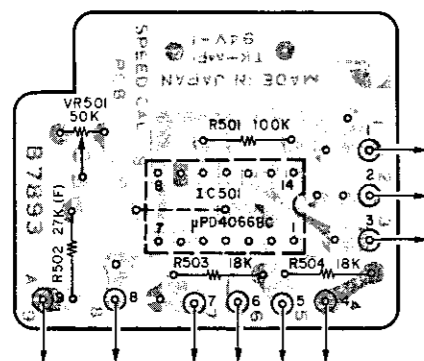

Fig. 1.8

1.9. Counter Pulse Generator P.C.B. Ass'y

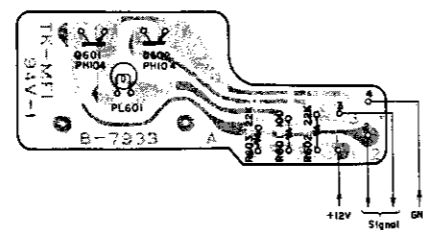

Fig. 1.9

1.10. Shut-off P.C.B. Ass'y

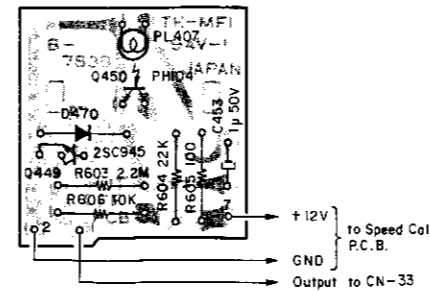

Fig. 1.10

Note: Diode is 1S553 unless otherwise specified.

Schematic Ref. No.	Part No.	Description
	BAL4240A	Function Switch P.C.B. Ass'y
PL701-708	OB07886A	Function Switch P.C.B.
SW701-708	OB08721A	Lamp 12V 30mA (8 pcs.)
CN15	OB07254A	Push Switch EVO-PXR04K (8 pcs.)
CN16	OBL8750B	6P-H Connector 500mm
17	OBL8751A	7P-H Connector 630mm
	OBL8749A	5P-H Connector 600mm
	BAL4239A	Mechanism Control Switch P.C.B. Ass'y
PL601-606	OB07887A	Mechanism Control Switch P.C.B.
SW601-606	OB08722A	Lamp 12V 60mA (6 pcs.)
CN31	OB07254A	Push Switch EVO-PXR04K (6 pcs.)
CN32	OBL8748A	8P-H Connector 200mm
	OBL8747A	7P-H Connector 200mm
	BA04238A	Speed Cal. P.C.B. Ass'y
IC501	OB07893A	Speed Cal P.C.B.
VR501	OB06144A	IC μPD4066BC
R501	OB07269A	Semi-fixed Volume 50K
R502	OB01889A	Carbon Resistor 100K ERD-25T J
R503,504	OB09444A	Metal Film Resistor 27K SN14K2E F
	OB05560A	Carbon Resistor 18K ERD-25T J
	BAL4237B	Counter Pulse Generator P.C.B. Ass'y
Q601,602	OB07933A	Counter Pulse Generator P.C.B.
R601	OB06228A	Photo Transistor PH104
R602,603	OB09215A	Fail Safe Type Resistor 100 RDF-25S J
PL601	OB05661A	Carbon Resistor 22K ERD-25V J
	OBL8552A	Lamp 12V 25mA
	OC08281B	P.C.B. Holder (1 pce.)
	OE00792A	BT Screw M2.6x6 Philips Pan Head (2 pcs.)
	BAL4070A	Shut-off P.C.B. Ass'y
Q449	OB07839A	Shut-off P.C.B.
Q450	OB01872A	Transistor 2SC945 (L)
D470	OB06228A	Photo Transistor PH104
R603	OB06181A	Silicon Diode 1S553
R604	OB05671A	Carbon Resistor 2.2M ERD-25T J
R605	OB05615A	Carbon Resistor 22K ERD-25T J
R606	OB09215A	Fail Safe Type Resistor 100 RDF-25S J
C453	OB01888A	Carbon Resistor 10K ERD-25T J
PL407	OB01405A	Electrolytic Capacitor 1μ 50V
	OBL8552A	Lamp 12V 25mA

1.11. FL Indicator P.C.B. A Ass'y

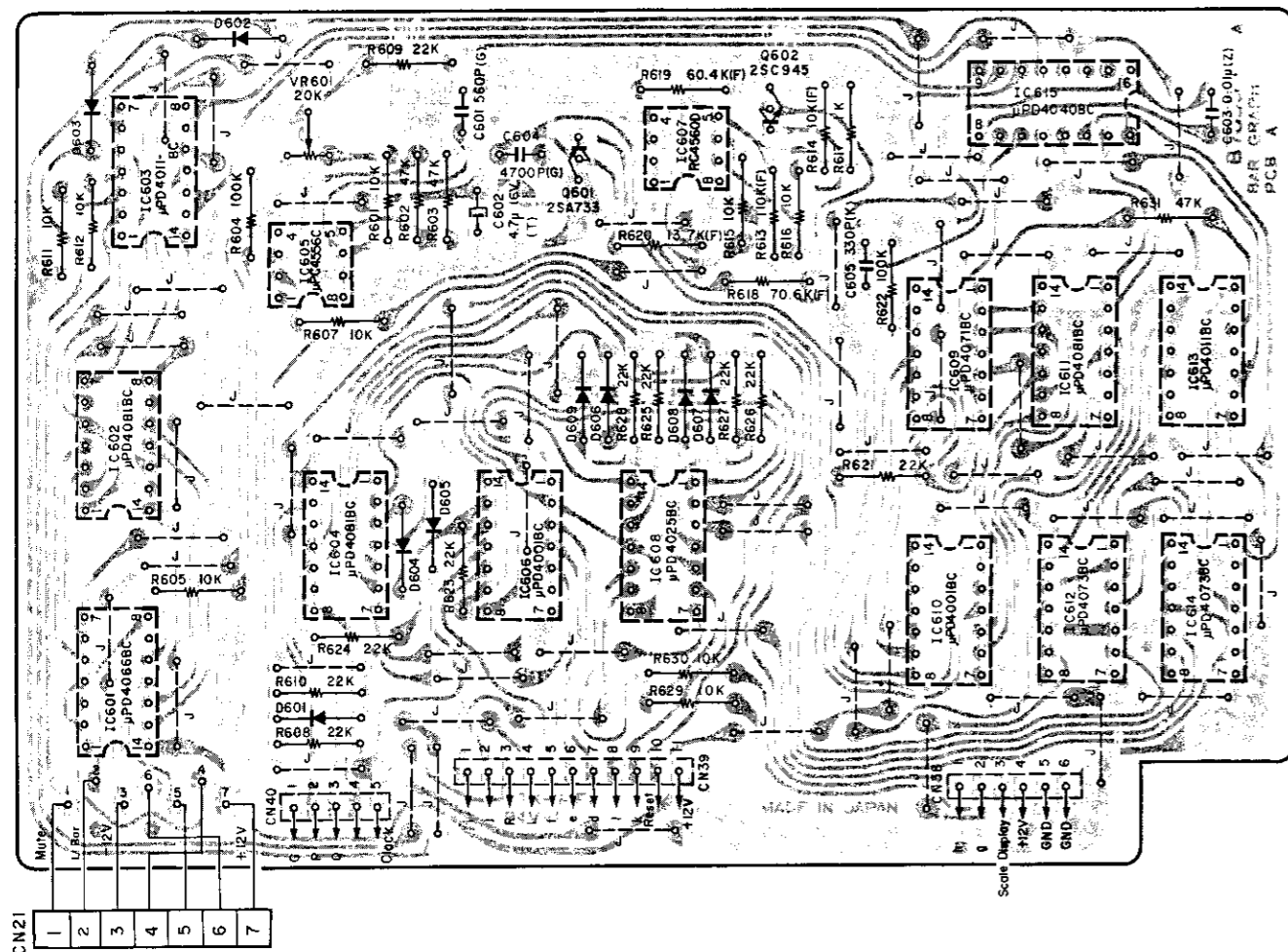

Fig. 1.11

Note: Diode is 1SS53 unless otherwise specified.

Schematic Ref. No.	Part No.	Description
	BAL4245A	FL Indicator P.C.B. A Ass'y
	0B07895A	FL Indicator P.C.B. A
IC601	0B06144A	IC μ PD4066BC
IC602,604,611	0B06219A	IC μ PD4081BC
IC603,613	0B06178A	IC μ PD4011BC
IC605	0B06216A	IC μ PC4556C
IC606,610	0B06143A	IC μ PD4001BC
IC607	0B06217A	IC RC4560D
IC608	0B06262A	IC μ PD4025BC
IC609	0B06214A	IC μ PD4071BC
IC612,614	0B06244A	IC μ PD4073BC
IC615	0B06223A	IC μ PD4040BC
Q601	0B06013A	Transistor 2SA733
Q602	0B06100A	Transistor 2SC945 (A)
D601-609	0B06181A	Silicon Diode 1SS53 (9 pcs.)
VR601	0B07270A	Semi-fixed Volume 20K
R601,605,607,611,612,615,616,629,630	0B01888A	Carbon Resistor 10K ERD-25T J
R602,603,631	0B05641A	Carbon Resistor 47K ERD-25T J
R604,622	0B01889A	Carbon Resistor 100K ERD-25T J
R608,609,610,621,623,624,625,626,627,628	0B05615A	Carbon Resistor 22K ERD-25T J
R613	0B09463A	Metal Film Resistor 110K SN14K2E F
R614	0B09203A	Metal Film Resistor 10K SN14K2E F
R617	0B01857A	Carbon Resistor 1K ERD-25T J
R618	0B09525A	Metal Film Resistor 70.6K SN14K2E F
R619	0B09524A	Metal Film Resistor 60.4K SN14K2E F
R620	0B09523A	Metal Film Resistor 13.7K SN14K2E F
C601	0B09414A	PP Capacitor 560P 100V G
C602	0B05657A	Tantalum Capacitor 4.7 μ 16V
C603	0B09290A	Ceramic Capacitor 0.01 μ 50V Z
C604	0B09191A	PP Capacitor 330P 50V K
C605	0B09285A	Ceramic Capacitor 330P 50V K
CN21	0BL8744A	7P-H Connector 200mm
CN38	0BL8734A	6P-T Connector F6P-HVQ
CN39	0BL8735A	11P-T Connector F11P-HVQ
CN40	0BL8733A	5P-T Connector F5P-HVQ

1.12. FL Indicator P.C.B. B Ass'y

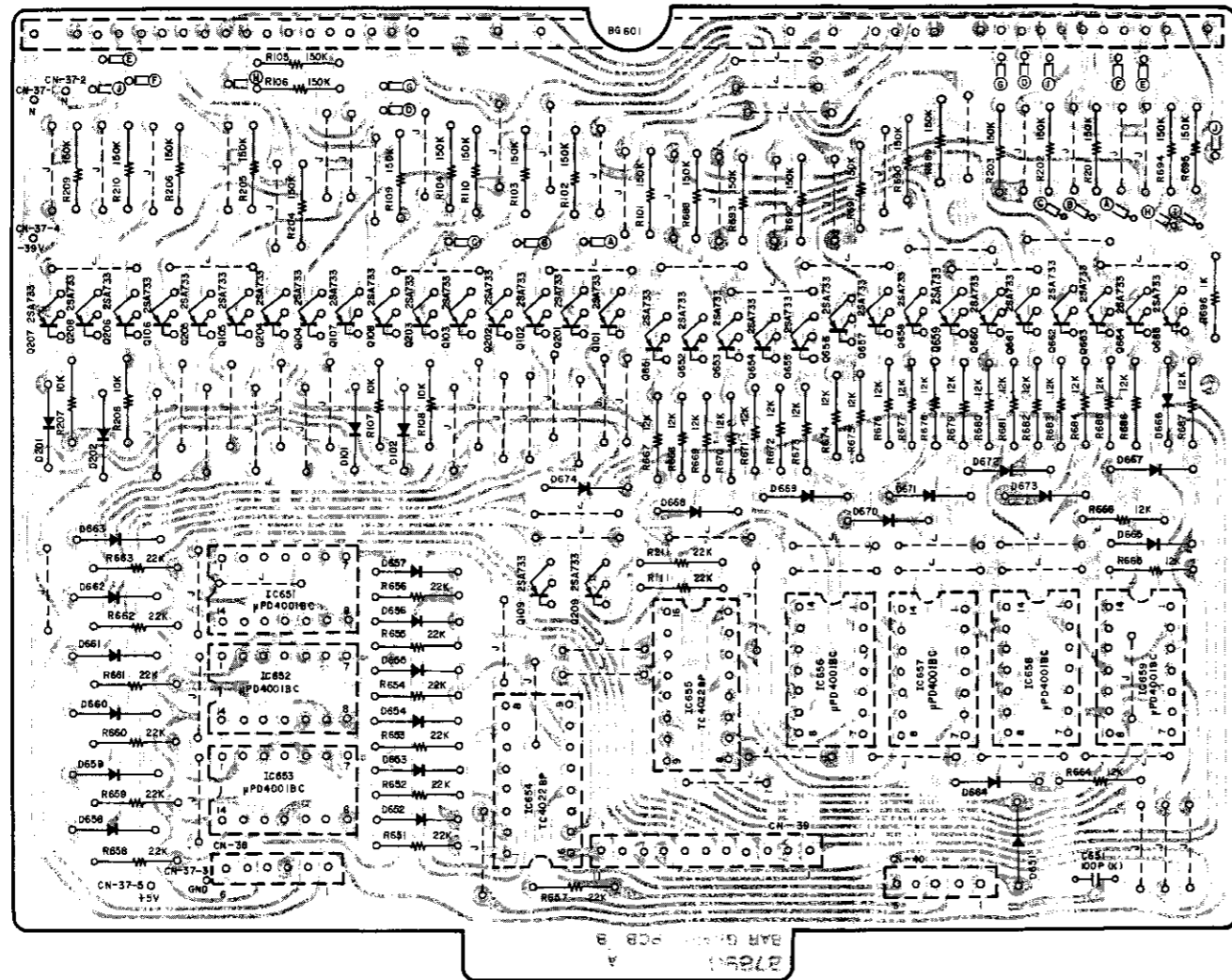

Fig. 1.12 Note: Diode is 1SS53 unless otherwise specified.

Schematic Ref. No.	Part No.	Description
	BAL4246A	FL Indicator P.C.B. B Ass'y
IC651-653	OB07896A	FL Indicator P.C.B. B
656-659	OB06143A	IC μ PD4001BC (7 pcs.)
IC654,655	OB06218A	IC TC4022BP
Q101-109	OB06013A	Transistor 2SA733 (33 pcs.)
201-209		
651-665		
D101,102	OB06181A	Silicon Diode 1SS53 (28 pcs.)
201,202		
651-674		
R101-106	OB05626A	Carbon Resistor 150K ERD-25T J (24 pcs.)
109,110		
201-206		
209,210		
688-695		
R107,108	OB01888A	Carbon Resistor 10K ERD-25T J
207,208		
R111,211	OB05615A	Carbon Resistor 22K ERD-25T J (15 pcs.)
651-663		
R664-687	OB09263A	Carbon Resistor 12K ERD-25T J (24 pcs.)
R696	OB01857A	Carbon Resistor 1K ERD-25T J
C651	OB09282A	Ceramic Capacitor 100P 50V K
BG601	OB08717A	FL Indicator FIP58BW18Y
CN37	OBL8745A	5P-H Connector
CN38	OBL8182A	6P-T Post
CN39	OBL8253A	11P-T Post
CN40	OBL8183A	5P-T Post

1.13. Detector P.C.B. Ass'y

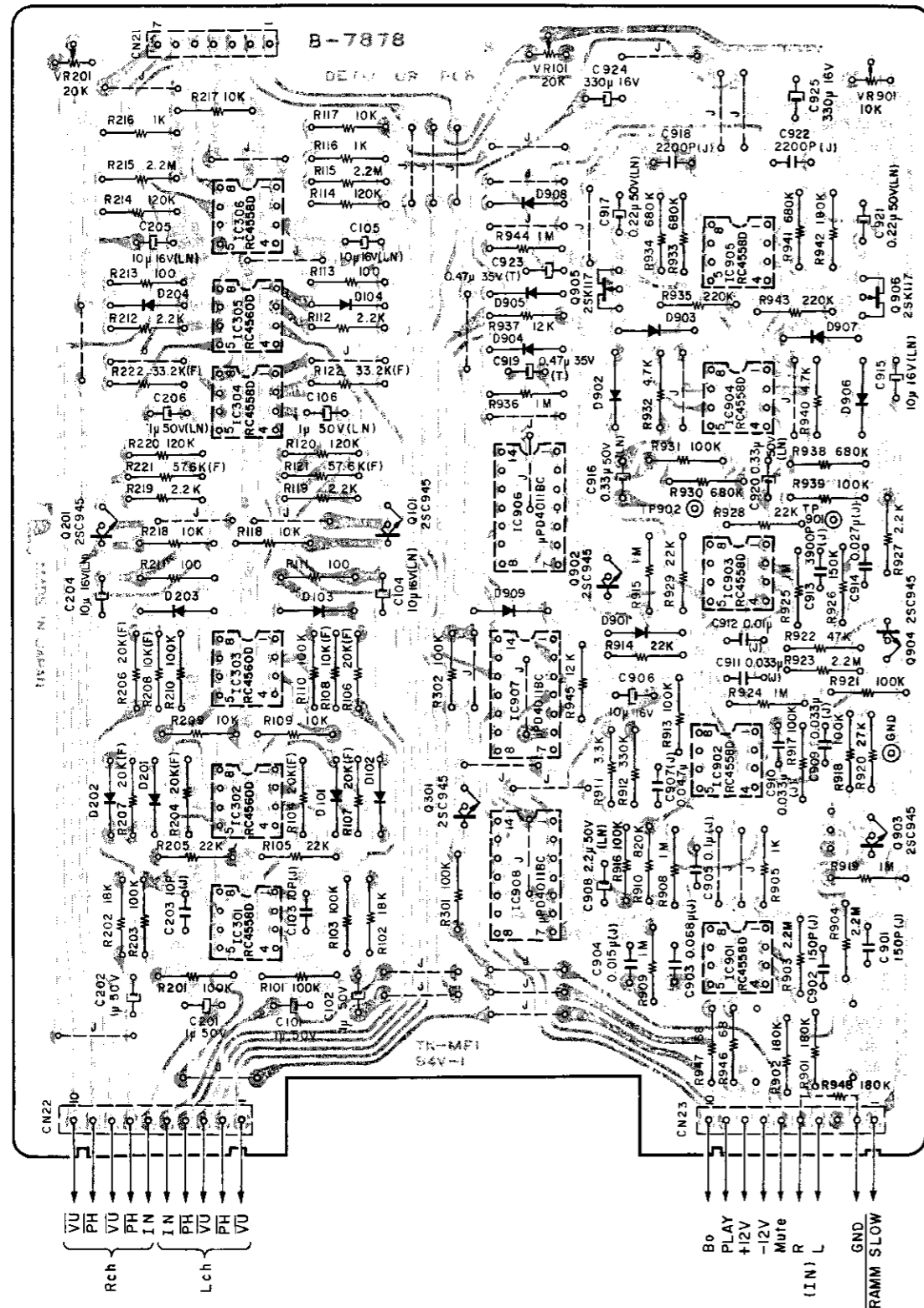

Fig. 1.13 Note: Diode is 1SS53 unless otherwise specified.

Schematic Ref. No.	Part No.	Description	Schematic Ref. No.	Part No.	Description
	BAL4230A	Detector P.C.B. Ass'y	R922	0B05641A	Carbon Resistor 47K ERD-25T J
	0B07878B	Detector P.C.B.	R926	0B05626A	Carbon Resistor 150K ERD-25T J
IC301,304	0B06124B	IC RC4558D	R930,933	0B09335A	Carbon Resistor 680K ERD-25T J
306,901			934,938		
902,903			941		
904,905			R932,940	0B01846A	Carbon Resistor 4.7K ERD-25T J
IC302,303	0B06217A	IC RC4560D	R935,943	0B05625A	Carbon Resistor 220K ERD-25T J
305			R937,945	0B09263A	Carbon Resistor 12K ERD-25T J
IC906,907	0B06178A	IC μ PD4011BC	R946,947	0B09306A	Fail Safe Type Resistor 68 RDF-25S J
908			C101,102	0B01405A	Electrolytic Capacitor 1 μ 50V
Q101,201	0B06100A	Transistor 2SC945 (A)	201,202		
301,902			C103,203	0B09277A	Ceramic Capacitor 10P 50V J
903,904			C104,105	0B09148A	Electrolytic Capacitor 10 μ 16V (LN)
Q905,906	0B06129A	FET 2SK117 (Y)	204,205		
D101-104	0B06181A	Silicon Diode 1SS53 (17 pcs.)	915		
201-204			C106,206	0B09223A	Electrolytic Capacitor 1 μ 50V (LN)
901-909			C901,902	0B09281A	Ceramic Capacitor 150P 50V J
VR101,201	0B07215A	Semi-fixed Volume 20K	C903	0B05682A	Mylar Capacitor 0.068 μ 50V J
VR901	0B07162A	Semi-fixed Volume 10K	C904	0B05557A	Mylar Capacitor 0.015 μ 50V J
R101,103	0B01889A	Carbon Resistor 100K ERD-25T J	C905	0B01780A	Mylar Capacitor 0.1 μ 50V J
110,201			C906	0B01412A	Electrolytic Capacitor 10 μ 16V
203,210			C907	0B05796A	Mylar Capacitor 0.047 μ 50V J
301,302			C908	0B09332A	Electrolytic Capacitor 2.2 μ 50V (LN)
913,916			C909,910	0B05583A	Mylar Capacitor 0.033 μ 50V J
917,918			911		
921,931			C912	0B05681A	Mylar Capacitor 0.01 μ 50V J
939			C913	0B01804A	Mylar Capacitor 3900P 50V J
R102,202	0B05560A	Carbon Resistor 18K ERD-25T J	C914	0B09045A	Mylar Capacitor 0.027 μ 50V J
R104,106	0B09439A	Metal Film Resistor 20K SN14K2E F	C916,920	0B09327A	Electrolytic Capacitor 0.33 μ 50V (LN)
107,204			C917,921	0B09144A	Electrolytic Capacitor 0.22 μ 50V (LN)
206,207			C918,922	0B01802A	Mylar Capacitor 2200P 50V J
R105,205	0B05615A	Carbon Resistor 22K ERD-25T J	C919,923	0B05792A	Tantalum Capacitor 0.47 μ 35V
914,928			C924,925	0B01502A	Electrolytic Capacitor 330 μ 16V
929			CN21	0BL8643A	7P-T Post
R108,208	0B09203A	Metal Film Resistor 10K SN14K2E F	CN22,23	0BL8731A	10P-S Connector F10P-SHVQ
R109,117	0B01888A	Carbon Resistor 10K ERD-25T J			
118,209					
217,218					
R111,113	0B01679A	Carbon Resistor 100 ERD-25T J			
211,213					
R112,119	0B05622A	Carbon Resistor 2.2K ERD-25T J			
212,219					
927					
R114,120	0B05621A	Carbon Resistor 120K ERD-25T J			
214,220					
R115,215	0B05671A	Carbon Resistor 2.2M ERD-25T J			
903,904					
923					
R116,216	0B01857A	Carbon Resistor 1K ERD-25T J			
905					
R121,221	0B09454A	Metal Film Resistor 57.6K SN14K2E F			
R122,222	0B09446A	Metal Film Resistor 33.2K SN14K2E F			
R901,902	0B05640A	Carbon Resistor 180K ERD-25T J			
942,948					
R908,909	0B05776A	Carbon Resistor 1M ERD-25T J			
915,919					
924,925					
936,944					
R910	0B09320A	Carbon Resistor 820K ERD-25T J			
R911	0B01681A	Carbon Resistor 3.3K ERD-25T J			
R912	0B05627A	Carbon Resistor 330K ERD-25T J			
R920	0B05743A	Carbon Resistor 27K ERD-25T J			

1.14. Record Dolby NR P.C.B. Ass'y

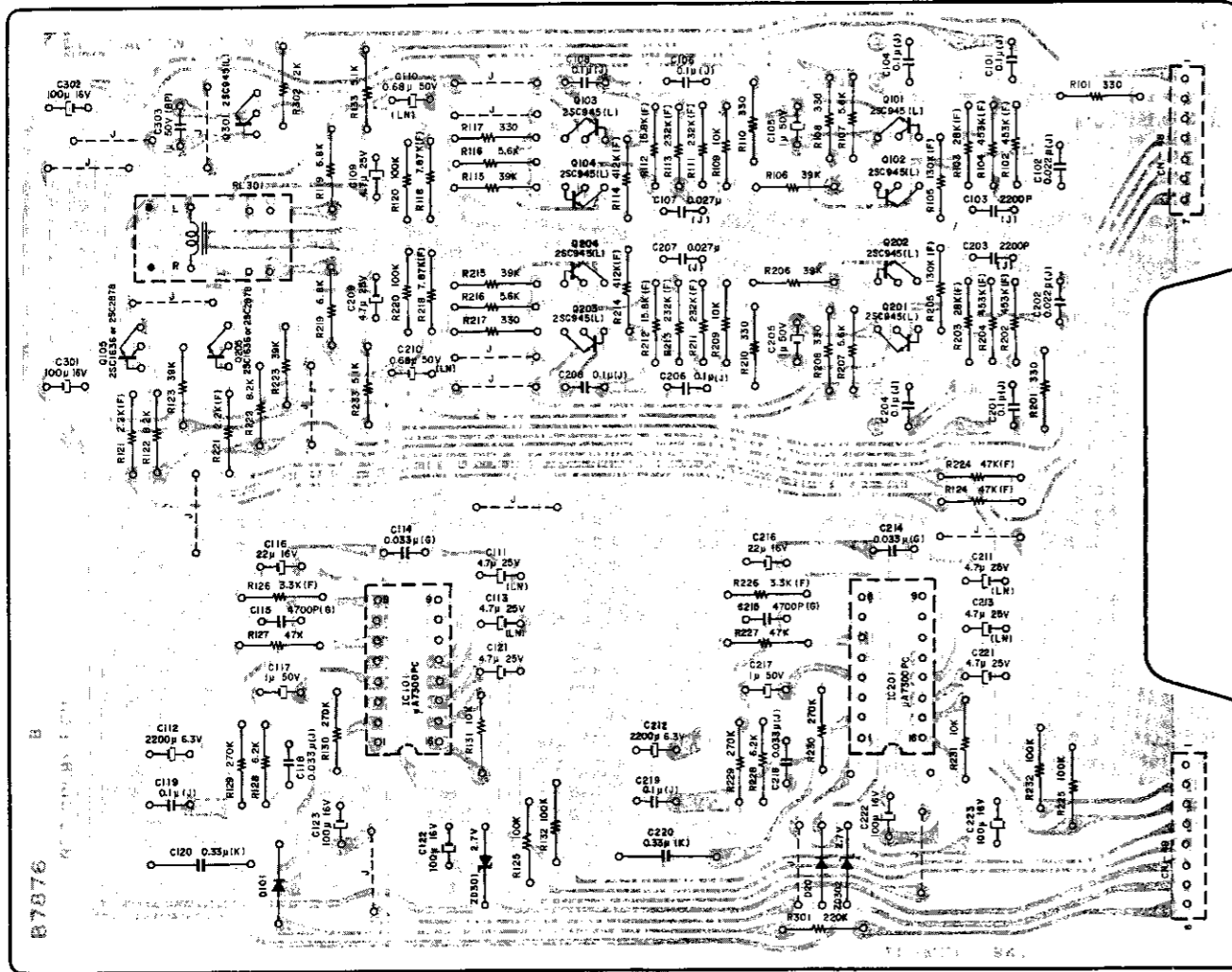

Fig. 1.14 Note: Diode is 1SS53 unless otherwise specified.

Schematic Ref. No.	Part No.	Description	Schematic Ref. No.	Part No.	Description
	BAL4236A	Record Dolby NR P.C.B. Ass'y	C112,212	OB09257A	Electrolytic Capacitor 2200µ 6.3V
	OB07876B	Record Dolby NR P.C.B.	C114,214	OB09240A	PP Capacitor 0.033µ 50V G
IC101,201	OB06200A	IC µA7300PC	C115,215	OB09191A	PP Capacitor 4700P 50V G
Q101,102	OB01872A	Transistor 2SC945 (L)	C116,216	OB01862A	Electrolytic Capacitor 22µ 16V
103,104			C118,218	OB05583A	Mylar Capacitor 0.033µ 50V J
201,202			C120,220	OB09399A	Mylar Capacitor 0.33µ 100V K
203,204			C122,123	OB01400A	Electrolytic Capacitor 100µ 16V
301			222,223		
Q105,205	OB06070A	Transistor 2SC1636 (2SC2878)	301,302		
ZD301,302	OB06191A	Zener Diode 2.7V 2.7EB	C303	OB09187A	Electrolytic Capacitor 1µ 50V (BP)
D101,201	OB01909A	Silicon Diode 1S1555	RL301	OB07326A	FBR Relay 12V
R101,108	OB05577A	Carbon Resistor 330 ERD-25T J	CN48	OB18729A	7P-S Connector F7P-SHVQ
110,117			CN49	OB18730A	8P-S Connector F8P-SHVQ
201,208			OB08714A	OB08714A	IC Socket 16P (2 pcs.)
210,217					
R102,104	OB09480A	Metal Film Resistor 453K SN14K2E F	BAL4231A	Record Eq. Amp. P.C.B. Ass'y	
202,204			OB07877A	Record Eq. Amp. P.C.B.	
R103,203	OB09445A	Metal Film Resistor 28K SN14K2E F	OB06144A	IC µPD4066BC	
R105,205	OB09466A	Metal Film Resistor 130K SN14K2E F	IC101,102	IC µPD4066BC	
R106,115	OB01854A	Carbon Resistor 39K ERD-25T J	304,305		
123,206			IC103,203	OB06261A	IC µPD4508BC
215,223			306,307		
R107,116	OB01887A	Carbon Resistor 5.6K ERD-25T J	IC301,302	OB06146A	IC RC4558DD
207,216			IC303	OB06287A	IC RC4558DD MC
R109,131	OB01888A	Carbon Resistor 10K ERD-25T J	Q101,102	OB01872A	Transistor 2SC945 (L)
209,231			103,104		
R111,113	OB09473A	Metal Film Resistor 232K SN14K2E F	201,202		
211,213			203,204		
R112,212	OB09437A	Metal Film Resistor 15.8K SN14K2E F	Q105,205	OB06013A	Transistor 2SA733
R114,214	OB09478A	Metal Film Resistor 412K SN14K2E F	L101,201	OB00068A	Trap Coil 10.5mH
R118,218	OB09430A	Metal Film Resistor 7.87K SN14K2E F	R101,121	OB05560A	Carbon Resistor 18K ERD-25T J
R119,219	OB01682A	Carbon Resistor 6.8K ERD-25T J	201,221		
R120,125	OB01888A	Carbon Resistor 100K ERD-25T J	R102,202	OB05621A	Carbon Resistor 120K ERD-25T J
132,220			R103,203	OB09442A	Metal Film Resistor 22.3K SN14K2E F
225,232			R104,204	OB09229A	Metal Film Resistor 18K SN14K2E F
R121,221	OB09420A	Metal Film Resistor 2.2K SN14K2E F	R105,205	OB09464A	Metal Film Resistor 121K SN14K2E F
R122,222	OB01856A	Carbon Resistor 8.2K ERD-25T J	R106,206	OB09454A	Metal Film Resistor 57.6K SN14K2E F
R124,224	OB09451A	Metal Film Resistor 47K SN14K2E F	R107,207	OB09443A	Metal Film Resistor 26.4K SN14K2E F
R126,226	OB09317A	Metal Film Resistor 3.3K SN14K2E F	R108,111	OB05508A	Carbon Resistor 56K ERD-25T J
R127,227	OB05641A	Carbon Resistor 47K ERD-25T J	114,142		
R128,228	OB09271A	Carbon Resistor 6.2K ERD-25T J	208,211		
R129,130	OB05620A	Carbon Resistor 270K ERD-25T J	214,242		
229,230			R109,112	OB05626A	Carbon Resistor 150K ERD-25T J
R133,233	OB09314A	Carbon Resistor 5.1K ERD-25T J	115,119		
R301	OB05625A	Carbon Resistor 220K ERD-25T J	143,209		
R302	OB09263A	Carbon Resistor 12K ERD-25T J	212,215		
C101,104	OB01780A	Mylar Capacitor 0.1µ 50V J	219,243		
106,108			R110,113	OB01854A	Carbon Resistor 39K ERD-25T J
119,201			116,144		
204,206			145,210		
208,219			213,216		
C102,202	OB05582A	Mylar Capacitor 0.022µ 50V J	244,245		
C103,203	OB01802A	Mylar Capacitor 2200P 50V J	R117,217	OB09428A	Metal Film Resistor 5.76K SN14K2E F
C105,117	OB01405A	Electrolytic Capacitor 1µ 50V	R118,218	OB05577A	Carbon Resistor 330 ERD-25T J
205,217			R120,220	OB05743A	Carbon Resistor 27K ERD-25T J
C107,207	OB09045A	Mylar Capacitor 0.027µ 50V J	R122,131	OB09203A	Metal Film Resistor 10K SN14K2E F
C109,121	OB01402A	Electrolytic Capacitor 4.7µ 25V	222,231		
209,221			R123,223	OB05620A	Carbon Resistor 270K ERD-25T J
C110,210	OB09395A	Electrolytic Capacitor 0.68µ 50V (LN)	R124,224	OB09466A	Metal Film Resistor 130K SN14K2E F
C111,113	OB09333A	Electrolytic Capacitor 4.7µ 25V (LN)	R125,225	OB09298A	Metal Film Resistor 64.9K SN14K2E F
211,213			R126,226	OB09446A	Metal Film Resistor 33.2K SN14K2E F
			R127,227	OB09438A	Metal Film Resistor 16.5K SN14K2E F

Schematic Ref. No.	Part No.	Description
R128,228	OB09431A	Metal Film Resistor 8.06K SN14K2E F
R129,229	OB09423A	Metal Film Resistor 4.02K SN14K2E F
R130,230	OB09419A	Metal Film Resistor 2K SN14K2E F
R132,232	OB09436A	Metal Film Resistor 14K SN14K2E F
R133,233	OB09335A	Carbon Resistor 680K ERD-25T J
R134,234	OB09380A	Carbon Resistor 1.5M ERD-25T J
R135,235	OB05962A	Carbon Resistor 1.2M ERD-25T J
R136,236	OB09357A	Metal Film Resistor 33K SN14K2E F
R137,237	OB09391A	Carbon Resistor 91K ERD-25T J
R138,238	OB05675A	Carbon Resistor 3.9K ERD-25T J
R139,239	OB01680A	Carbon Resistor 820 ERD-25T J
R140,240	OB05641A	Carbon Resistor 47K ERD-25T J
R141,241	OB05622A	Carbon Resistor 2.2K ERD-25T J
R146,246	OB05627A	Carbon Resistor 330K ERD-25T J
R147-154	OB05625A	Carbon Resistor 220K ERD-25T J (24 pcs.)
R301,302	OB09049A	Fail Safe Type Resistor 22 ERD-14F J
C101,201	OB09045A	Mylar Capacitor 0.027μ 50V J
C102,202	OB09223A	Electrolytic Capacitor 1μ 50V (LN)
C103,119	OB09403A	PP Capacitor 620P 100V J
C104,204	OB05687A	Mylar Capacitor 1200P 50V J
C105,205	OB01802A	Mylar Capacitor 2200P 50V J
C106,206	OB05636A	Tantalum Capacitor 22μ 16V
C107,207	OB09247A	Mica Capacitor 220P 50V J
C108,110	OB09488A	Ceramic Capacitor 30P 50V J
C208,210		
C109,209	OB09484A	PP Capacitor 470P 100V G
C111,211	OB09408A	PP Capacitor 1000P 100V G
C112,212	OB09485A	PP Capacitor 680P 100V G
C113,213	OB09486A	Mica Capacitor 120P 50V J
C114,214	OB09397A	Electrolytic Capacitor 470μ 10V (LN)
C115,215	OB09412A	PP Capacitor 0.011μ 100V G
C116,216	OB09094A	Tantalum Capacitor 1μ 50V
C117,217	OB09375A	Electrolytic Capacitor 47μ 10V (LN)
C118,218	OB05909A	Mylar Capacitor 0.12μ 50V J
C120,220	OB09189A	Mylar Capacitor 2700P 50V J
C121,221	OB01913A	Mylar Capacitor 1800P 50V J
C301,302	OB01502A	Electrolytic Capacitor 330μ 16V
CN45,46	OB08727A	5P-S Connector F5P-SHVQ
CN51	OBL8644A	8P-T Post
CN52	OBL8654A	4P-T Post

1.15. Record Eq. Amp. P.C.B. Ass'y

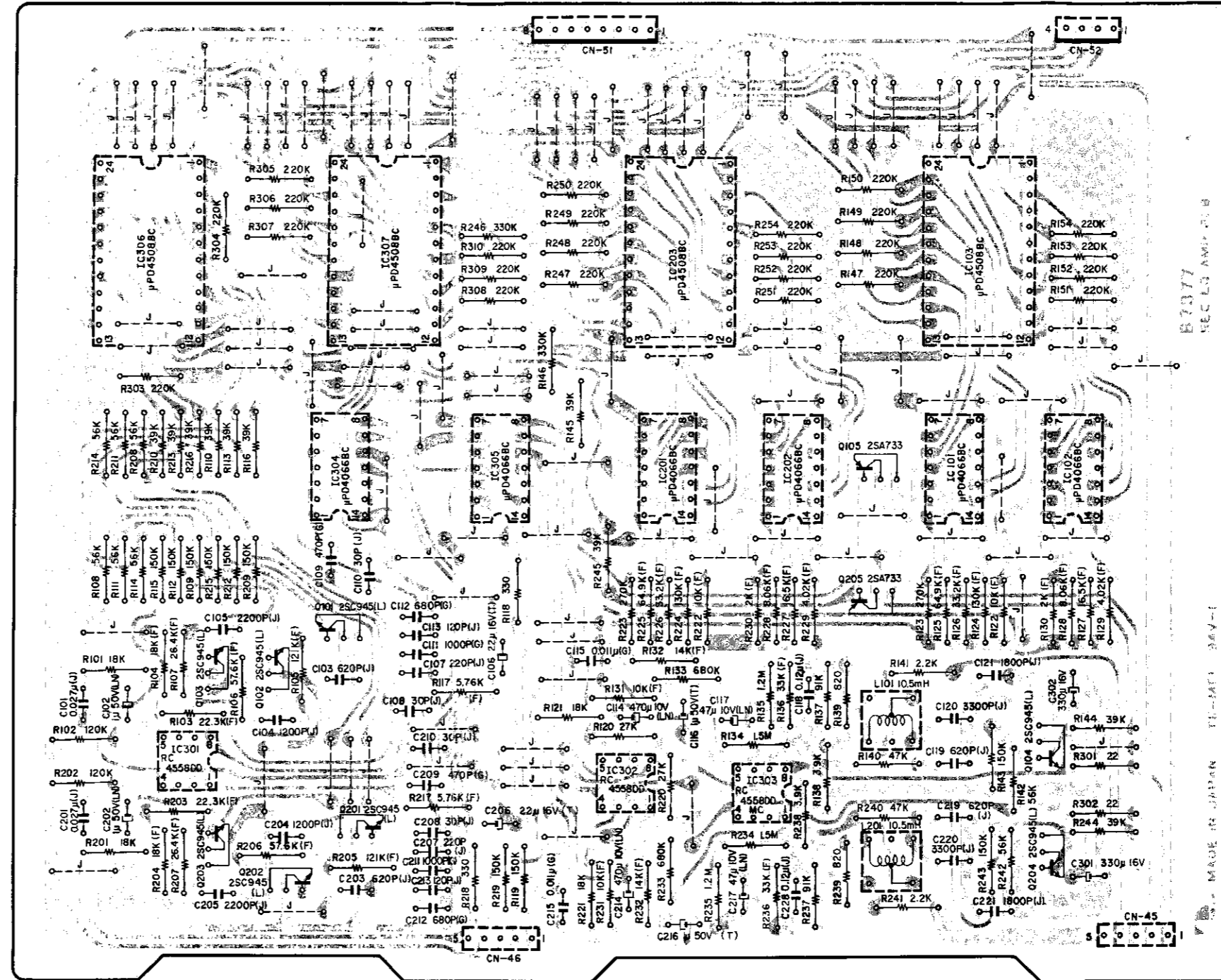
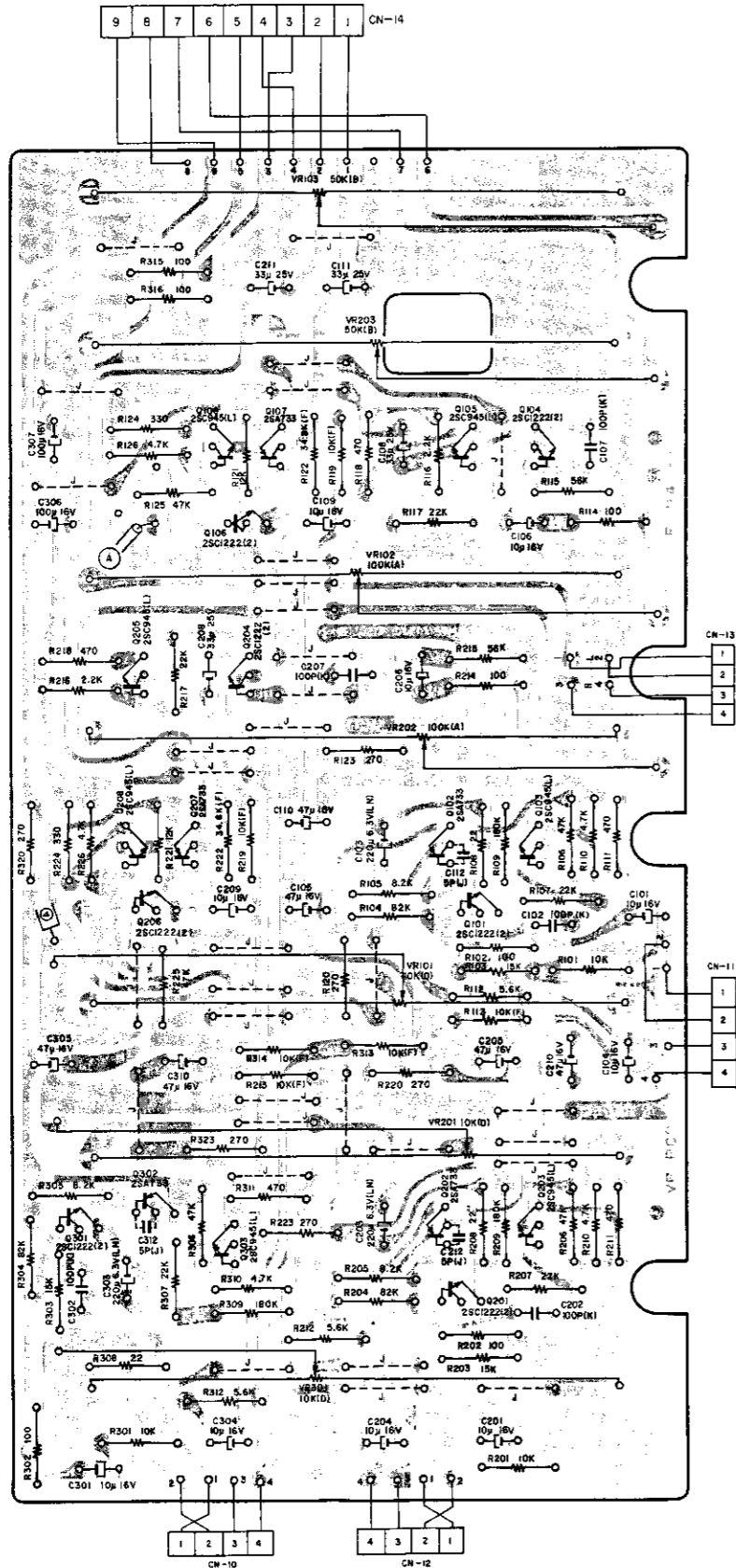

Fig. 1.15

Note: Diode is 1SS53 unless otherwise specified.

1.16. MIC Amp. and Volume P.C.B. Ass'y



Note: Diode is 1SS53 unless otherwise specified.

Fig. 1.16

Schematic Ref. No.	Part No.	Description	Schematic Ref. No.	Part No.	Description
	BAL4232A	MIC Amp. and Volume P.C.B. Ass'y	C102,107	OB09282A	Ceramic Capacitor 100P 50V K
	OB07884B	MIC Amp. and Volume P.C.B.	202,207		
Q101,104	OB06062A	Transistor 2SC1222 (2)	C103,203	OB09151A	Electrolytic Capacitor 220µ 6.3V(LN)
106,201			303		
204,206			C105,110	OB01403A	Electrolytic Capacitor 47µ 16V
301			205,210		
Q102,107	OB06013A	Transistor 2SA733	305,310		
202,207			C108,111	OB09251A	Electrolytic Capacitor 33µ 25V
302			208,211		
Q103,105	OB01872A	Transistor 2SC945 (L)	C112,212	OB09276A	Ceramic Capacitor 5P 50V J
108,203			312		
205,208			C306,307	OB01400A	Electrolytic Capacitor 100µ 16V
303			CN10	OBL8754A	4P-H Connector 520mm
VR101,201	OB07331A	Slide Volume 10K (D)	CN11	OBL8779A	4P-H Connector
301			CN12	OBL8780A	4P-H Connector
VR102,202	OB07332A	Slide Volume 100K (A)	CN13	OBL8755A	4P-H Connector 320mm
VR103,203	OB07333A	Slide Volume 50K (B)	CN14	OBL8753B	9P-H Connector 320mm
R101,201	OB01888A	Carbon Resistor 10K ERD-25T J		BAL4235A	Playback Amp. and Dolby NR P.C.B. Ass'y
301				OB07875C	Playback Amp. and Dolby NR P.C.B.
R102,202	OB01679A	Carbon Resistor 100 ERD-25T J	IC101,201	OB06200A	IC µA7300PC
114,214			IC301	OB06205A	IC RC4559DD
302			Q101,201	OB06257A	FET 2SK240 (BL)
R103,203	OB01683A	Carbon Resistor 15K ERD-25T J	(OB06300A)	OB01872A	Transistor 2SC945 (L)
303					
R104,204	OB05668A	Carbon Resistor 82K ERD-25T J	Q102,103		
304			104,202		
R105,205	OB01856A	Carbon Resistor 8.2K ERD-25T J	203,204		
305			ZD301,302	OB06191A	Zener Diode 2.7V 2.7EB
R106,125	OB05641A	Carbon Resistor 47K ERD-25T J	ZD303,304	OB06233A	Zener Diode 10V RD10EB3
206,225			D101,201	OB01909A	Silicon Diode 1S1555
306			L101,201	OB06636A	Inductor 1.05mH
R107,117	OB05615A	Carbon Resistor 22K ERD-25T J	L102,202	OB00068A	Trap Coil 10.5mH
207,217			L103,203	OB03919B	Inductor 36mH
307			VR101,201	OB07353A	Semi-fixed Volume 200
R108,208	OB05579A	Carbon Resistor 22 ERD-25T J	VR102,202	OB07162A	Semi-fixed Volume 10K
308			R101,124	OB05615A	Carbon Resistor 22K ERD-25T J
R109,209	OB05640A	Carbon Resistor 180K ERD-25T J	201,224		
309			R102,202	OB09317A	Metal Film Resistor 3.3K SN14K2E F
R110,126	OB01846A	Carbon Resistor 4.7K ERD-25T J	R103,107	OB01846A	Carbon Resistor 4.7K ERD-25T J
210,226			203,207		
310			R104,204	OB01933A	Carbon Resistor 220 ERD-25T J
R111,118	OB05576A	Carbon Resistor 470 ERD-25T J	R105,205	OB09415A	Metal Film Resistor 68 SN14K2E F
211,218			R106,122	OB09422A	Metal Film Resistor 3.16K SN14K2E F
311			206,222		
R112,212	OB01887A	Carbon Resistor 5.6K ERD-25T J	R108,132	OB01889A	Carbon Resistor 100K ERD-25T J
312			208,232		
R113,119	OB09203A	Metal Film Resistor 10K SN14K2E F	R109,209	OB09521A	Metal Film Resistor 523K SN14K2E F
213,219			R110,210	OB09205A	Metal Film Resistor 18K SN14K2E F
313,314			R111,112	OB01857A	Carbon Resistor 1K ERD-25T J
R115,215	OB05508A	Carbon Resistor 56K ERD-25T J	113,211		
R116,216	OB05622A	Carbon Resistor 2.2K ERD-25T J	212,213		
R120,123	OB05645A	Carbon Resistor 270 ERD-25T J	R114,116	OB09520A	Carbon Resistor 620K ERD-25T J
220,223			214,216		
320,323			R115,128	OB05620A	Carbon Resistor 270K ERD-25T J
R121,221	OB09263A	Carbon Resistor 12K ERD-25T J	130,215		
R122,222	OB09447A	Metal Film Resistor 34.8K SN14K2E F	228,230		
R124,224	OB05577A	Carbon Resistor 330 ERD-25T J	R117,217	OB05676A	Carbon Resistor 390K ERD-25T J
R315,316	OB09215A	Fail Safe Type Resistor 100 RDF-25S J	R118,218	OB01854A	Carbon Resistor 39K ERD-25T J
C101,104	OB01412A	Electrolytic Capacitor 10µ 16V	R119,219	OB01887A	Carbon Resistor 5.6K ERD-25T J
106,109			R120,220	OB05577A	Carbon Resistor 330 ERD-25T J
201,204			R121,221	OB09421A	Metal Film Resistor 2.67K SN14K2E F
206,209					
301,304					

Schematic Ref. No.	Part No.	Description
R123,127	OB05641A	Carbon Resistor 47K ERD-25T J
223,227		
R125,131	OB01888A	Carbon Resistor 10K ERD-25T J
225,231		
R126,226	OB09317A	Metal Film Resistor 3.3K SN14K2E F
R129,229	OB09271A	Carbon Resistor 6.2K ERD-25T J
R133,233	OB05671A	Carbon Resistor 2.2M ERD-25T J
R134,234	OB05558A	Carbon Resistor 100 ERD-25V J
R301	OB05625A	Carbon Resistor 220K ERD-25T J
R303,304	OB09306A	Fail Safe Type Resistor 68 RDF-25S J
C101,201	OB09486A	Mica Capacitor 120P 50V J
C102,202	OB05681A	Mylar Capacitor 0.01μ 50V J
C103,203	OB09152A	Electrolytic Capacitor 470μ 6.3V (LN)
C104,204	OB09489A	PP Capacitor 5600P 100V G
C105,205	OB05550A	Mylar Capacitor 1000P 50V J
C106,206	OB09345A	Electrolytic Capacitor 3.3μ 25V (BP)
C107,108	OB01400A	Electrolytic Capacitor 100μ 16V
128,129		
207,208		
228,229		
303,304		
305,306		
C109,209	OB09410A	PP Capacitor 2200P 100V J
C110,113	OB09189A	Mylar Capacitor 2700P 50V J
210,213		
C111,211	OB09275A	Mica Capacitor 200P 50V J
C112,212	OB09235A	PP Capacitor 680P 100V J
C114,116	OB05813A	Mylar Capacitor 0.056μ 50V J
214,216		
C115,126	OB01780A	Mylar Capacitor 0.1μ 50V J
215,226		
C117,217	OB09413A	PP Capacitor 0.022μ 100V G
C118,122	OB09333A	Electrolytic Capacitor 4.7μ 25V (LN)
218,222		
C119,219	OB09257A	Electrolytic Capacitor 2200μ 6.3V
C120,220	OB09240A	PP Capacitor 0.033μ 100V G
C121,221	OB09191A	PP Capacitor 4700P 100V G
C123,223	OB01862A	Electrolytic Capacitor 22μ 16V
C124,224	OB01405A	Electrolytic Capacitor 1μ 50V
C125,225	OB05583A	Mylar Capacitor 0.033μ 50V J
C127,227	OB09399A	Mylar Capacitor 0.33μ 100V K
C130,230	OB09400A	Mica Capacitor 250P 50V J
C131,231	OB09270A	PP Capacitor 470P 50V J
C301,302	OB01412A	Electrolytic Capacitor 10μ 16V
CN46	OBL8727A	5P-S Connector F5P-SHVQ
CN47	OBL8728A	6P-S Connector F6P-SHVQ
CN53	OBL8654A	4P-T Post
	OB08714A	IC Socket 16P (2 pcs.)

1.17. Playback Amp. and Dolby NR P.C.B. Ass'y

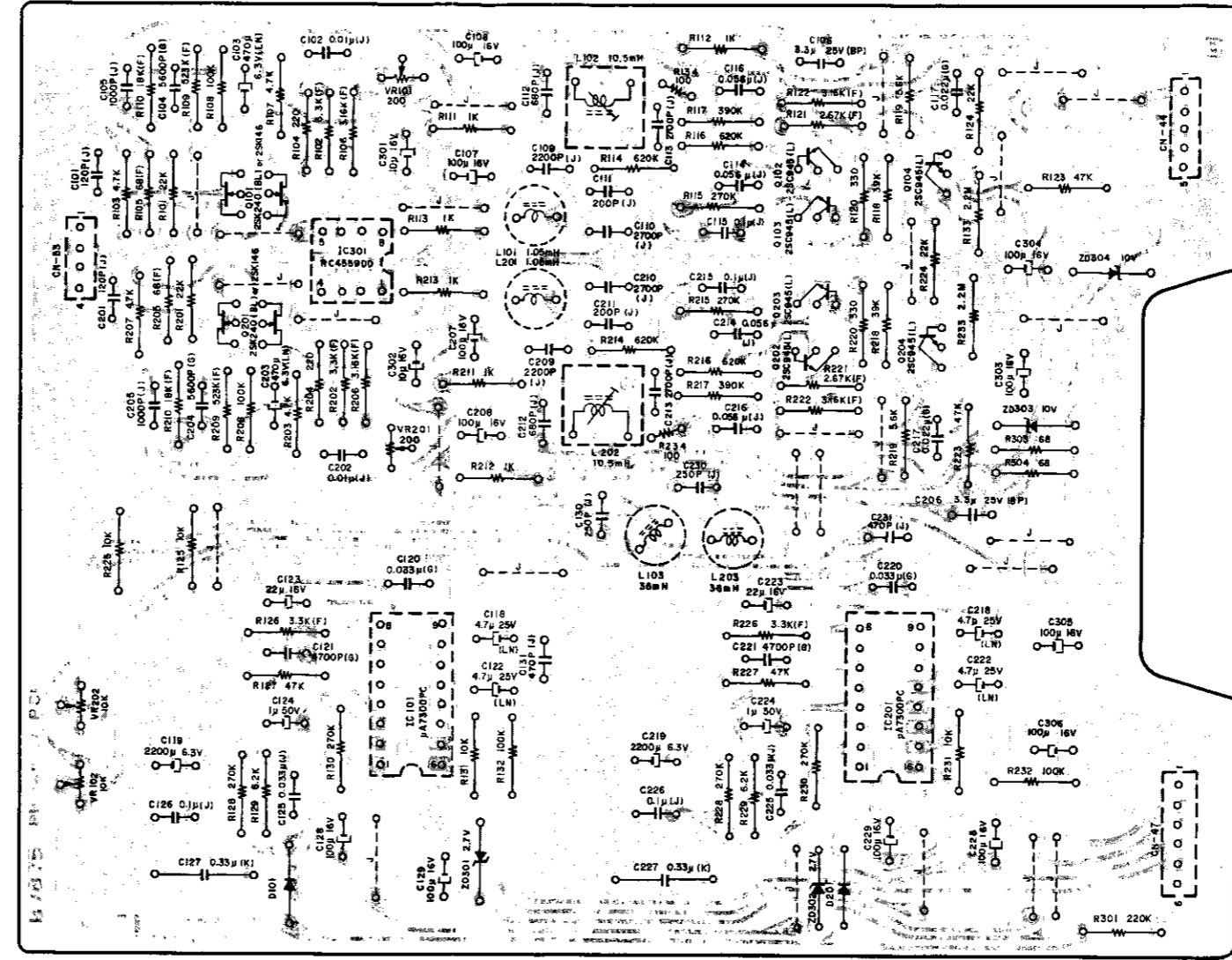

Fig. 1.17 Note: Diode is 1SS53 unless otherwise specified.

1.18. Main P.C.B. Ass'y

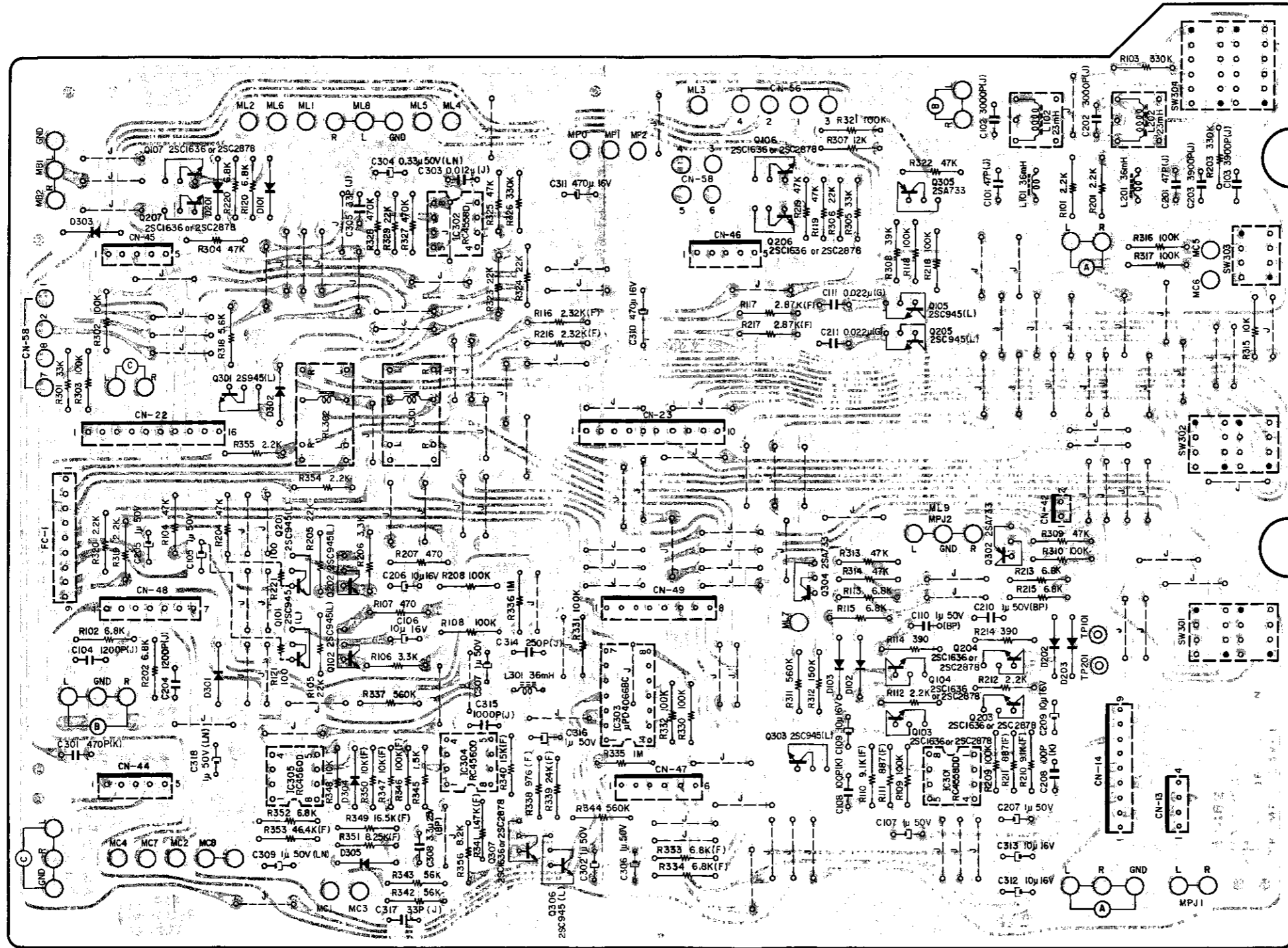

Fig. 1.18

Note: Diode is 1SS53 unless otherwise specified.

Schematic Ref. No.	Part No.	Description	Schematic Ref. No.	Part No.	Description
	BAL4227A	Main P.C.B. Ass'y	R311,337 344	OB05784A	Carbon Resistor 560K ERD-25T J
IC301	OB07882C	Main P.C.B.	R312	OB05626A	Carbon Resistor 150K ERD-25T J
IC302	OB06146A	IC RC4558DD	R315,348	OB01888A	Carbon Resistor 10K ERD-25T J
IC303	OB06124B	IC RC4558D	R318	OB01887A	Carbon Resistor 5.6K ERD-25T J
IC304,305	OB06144A	IC μ PD4066BC	R327,328	OB01684A	Carbon Resistor 470K ERD-25T J
Q101,102	OB06217A	IC RC4560D	R333,334	OB09529A	Metal Film Resistor 6.8K SN14K2E F
105,201	OB01872A	Transistor 2SC945 (L)	R335,336	OB05776A	Carbon Resistor 1M ERD-25T J
202,205			R338	OB09416A	Metal Film Resistor 976 SN14K2E F
301,303			R339	OB09005A	Metal Film Resistor 24K SN14K2E F
306			R340	OB09340A	Metal Film Resistor 15K SN14K2E F
Q103,104	OB06070A	Transistor 2SC1636	R341	OB09551A	Metal Film Resistor 1.47K SN14K2E F
106,107	(OB06299A)	(2SC2878)	R342,343	OB05508A	Carbon Resistor 56K ERD-25T J
203,204			R345	OB05698A	Carbon Resistor 1.5K ERD-25T J
206,207			R346	OB09305A	Metal Film Resistor 100K SN14K2E F
307			R347,350	OB09203A	Metal Film Resistor 10K SN14K2E F
Q302,304	OB06013A	Transistor 2SA733	R349	OB09438A	Metal Film Resistor 16.5K SN14K2E F
305			R351	OB09432A	Metal Film Resistor 8.25K SN14K2E F
D101-103	OB06181A	Silicon Diode 1SS53 (11 pcs.)	R353	OB09450A	Metal Film Resistor 46.4K SN14K2E F
201-203			R356	OB01856A	Carbon Resistor 8.2K ERD-25T J
301-305			C101,201	OB09242A	Mica Capacitor 47P 50V J
L101,201	OB03919B	Inductor 36mH	C102,202	OB09262A	PP Capacitor 3000P 50V J
301			C103,203	OB01804A	Mylar Capacitor 3900P 50V J
L102,202	OB03563A	19K Coil 23mH	C104,204	OB05687A	Mylar Capacitor 1200P 50V J
R101,112	OB05622A	Carbon Resistor 2.2K ERD-25T J	C105,107	OB01405A	Electrolytic Capacitor 1 μ 50V
201,212			205,207		
319,320			302,306		
354,355			307,316		
R102,113	OB01682A	Carbon Resistor 6.8K ERD-25T J	C106,109	OB01412A	Electrolytic Capacitor 10 μ 16V
115,120			206,209		
202,213			312,313		
215,220			C108,208	OB09282A	Ceramic Capacitor 100P 50V K
352			C110,210	OB09187A	Electrolytic Capacitor 1 μ 50V (BP)
R103,203	OB05627A	Carbon Resistor 330K ERD-25T J	C111,211	OB09413A	PP Capacitor 0.022 μ 100V G
326			C301	OB09286A	Ceramic Capacitor 470P 50V K
R104,119	OB05641A	Carbon Resistor 47K ERD-25T J	C303	OB05843A	Mylar Capacitor 0.012 μ 50V J
204,219			C304	OB09385A	Electrolytic Capacitor 0.33 μ 50V (LN)
304,309			C305,317	OB09370A	Ceramic Capacitor 33P 50V J
313,314			C308	OB09345A	Electrolytic Capacitor 3.3 μ 25V (BP)
322,325			C309,318	OB09223A	Electrolytic Capacitor 1 μ 50V (LN)
R105,205	OB05615A	Carbon Resistor 22K ERD-25T J	C310,311	OB01392A	Electrolytic Capacitor 470 μ 16V
306,323			C314	OB09400A	Mica Capacitor 250P 50V J
324,329			C315	OB05550A	Mylar Capacitor 1000P 50V J
R106,206	OB01681A	Carbon Resistor 3.3K ERD-25T J	RL301,302	OB07326A	FBR Relay 12V
R107,207	OB05576A	Carbon Resistor 470 ERD-25T J	SW301	OB07324A	Rotary Switch 4-2N
R108,109	OB01889A	Carbon Resistor 100K ERD-25T J	SW302	OB07322A	Rotary Switch 4-2S
118,208			SW303	OB07323A	Rotary Switch 2-3N
209,218			SW304	OB07321A	Rotary Switch 4-4S
302,303			CN13	OBL8654A	4P-T Post
310,316			CN14	OBL8645A	9P-T Post
317,321			CN22,23	OBL8615A	10P-T Post B10P-SHF-1
330,331			CN42	OBL8656A	2P-T Post
332			CN44,45	OBL8183A	5P-T Post B5P-SHF-1
R110,210	OB09328A	Metal Film Resistor 9.1K SN14K2E F	46		
R111,211	OB09550A	Metal Film Resistor 887 SN14K2E F	CN47	OBL8182A	6P-T Post B6P-SHF-1
R114,214	OB05691A	Carbon Resistor 390 ERD-25T J	CN48	OBL8302A	7P-T Post B7P-SHF-1
R116,216	OB09468A	Metal Film Resistor 2.32K SN14K2E F	CN49	OBL8334A	8P-T Post B8P-SHF-1
R117,217	OB09758A	Metal Film Resistor 2.87K SN14K2E F	CN56	OBL8736A	4P-H Connector 600mm
R121,221	OB01679A	Carbon Resistor 100 ERD-25T J	CN58	OBL8737A	8P-H Connector 500mm
R301,305	OB05509A	Carbon Resistor 33K ERD-25T J			
R307	OB09263A	Carbon Resistor 12K ERD-25T J			
R308	OB01854A	Carbon Resistor 39K ERD-25T J			

Schematic Ref. No.	Part No.	Description	Schematic Ref. No.	Part No.	Description
	BAL4244B	Logic P.C.B. Ass'y	R502,517	OB05625A	Carbon Resistor 220K ERD-25T J
			598,614		
			639,641		
IC301	OB07879C	Logic P.C.B.	R503	OB05577A	Carbon Resistor 330 ERD-25T J
IC501,505	OB06217A	IC RC4560D	R504,519	OB05509A	Carbon Resistor 33K ERD-25T J
510,513	OB06124B	IC RC4558D	536,597		
IC502	OB06143A	IC μ PD4001BC	647,648		
IC503,504	OB06263A	IC μ PD4012BC	649,650		
IC506	OB06219A	IC μ PD4081BC	666		
IC507,508	OB06178A	IC μ PD4011BC	R505	OB05743A	Carbon Resistor 27K ERD-25T J
515,516			R506,523	OB05776A	Carbon Resistor 1M ERD-25T J
IC509	OB06270A	IC μ PD4069C	555,616		
IC511	OB06216A	IC μ PC4556C	629,630		
IC512	OB06213A	IC TC4013BP	632,633		
IC514	OB06244A	IC μ PD4073BC	638,675		
Q101,201	OB06066A	Transistor 2SD471	682		
504,506			R507	OB05692A	Carbon Resistor 68K ERD-25T J
538			R508	OB05508A	Carbon Resistor 56K ERD-25T J
Q102,202	OB06069A	Transistor 2SB564	R512,513	OB01856A	Carbon Resistor 8.2K ERD-25T J
507,539			R514	OB05622A	Carbon Resistor 2.2K ERD-25T J
Q501-503	OB06100A	Transistor 2SC945 (A)	R515,516	OB01887A	Carbon Resistor 5.6K ERD-25T J
508-520		(30 pcs.)	655,656		
523,525			R518	OB09475A	Metal Film Resistor 316K SN14K2E F
527,528			R520	OB09457A	Metal Film Resistor 71.5K SN14K2E F
530-536			R521	OB09474A	Metal Film Resistor 280K SN14K2E F
540-542			R522,524	OB09453A	Metal Film Resistor 51.1K SN14K2E F
Q505	OB06303A	Transistor 2SB772	R525,526	OB09305A	Metal Film Resistor 100K SN14K2E F
Q521,522	OB06013A	Transistor 2SA733	R528	OB09452A	Metal Film Resistor 49.9K SN14K2E F
524,526			R532	OB01846A	Carbon Resistor 4.7K ERD-25T J
529,537			R533,538	OB01888A	Carbon Resistor 10K ERD-25T J
D501-558	OB01909A	Silicon Diode 1S1555 (58 pcs.)	541,543		
VR501,504	OB07256A	Semi-fixed Volume 10K	563,564		
505			595,612		
VR502,503	OB07330A	Semi-fixed Volume 500K	613,618		
507			624,651		
VR506	OB07329A	Semi-fixed Volume 2K	652,658		
R101,102	OB01889A	Carbon Resistor 100K ERD-25T J	660,670		
201,202			684,685		
509,511			R534,551	OB05668A	Carbon Resistor 82K ERD-25T J
529,530			552		
531,537			R535,545	OB01857A	Carbon Resistor 1K ERD-25T J
539,547			553,643		
565,566			644,676		
591,593			R540	OB09217A	Fail Safe Type Resistor 5.6RDF-25S J
600,607			R542,544	OB01684A	Carbon Resistor 470K ERD-25T J
608,609			546,548		
611,622			549,550		
627,640			623,636		
642,653			637		
654,664			R556,615	OB09335A	Carbon Resistor 680K ERD-25T J
677,678			R557,559	OB05627A	Carbon Resistor 330K ERD-25T J
679,680			583-590		(21 pcs.)
681			592,596		
R103,203	OB01706A	Carbon Resistor 47 ERD-25T J	601-605		
R104,204	OB09321A	Fail Safe Type Resistor 4.7 RDF-25S J	645,646		
R501,510	OB05671A	Carbon Resistor 2.2M ERD-25T J	672,674		
527,554			R558	OB09440A	Metal Film Resistor 21.5K SN14K2E F
599,628			R560	OB09300A	Metal Film Resistor 150K SN14K2E F
631,659			R561	OB09471A	Metal Film Resistor 205K SN14K2E F
661,662			R562	OB09438A	Metal Film Resistor 16.5K SN14K2E F
663,667			R567,568	OB05560A	Carbon Resistor 18K ERD-25T J
673			570,574		

Schematic Ref. No.	Part No.	Description
R569,577	OB01683A	Carbon Resistor 15K ERD-25T J
R571,573 606,619 626,635	OB09216A	Fail Safe Type Resistor 10 RDF-25S J
R572	OB09215A	Fail Safe Type Resistor 100 RDF-25S J
R575,576 683	OB01681A	Carbon Resistor 3.3K ERD-25T J
R578,579 580,581	OB05626A	Carbon Resistor 150K ERD-25T J
R582,686	OB05784A	Carbon Resistor 560K ERD-25T J
R594,617 620,621 634,657 671	OB05615A	Carbon Resistor 22K ERD-25T J
R610	OB05641A	Carbon Resistor 47K ERD-25T J
R625	OB09263A	Carbon Resistor 12K ERD-25T J
R665	OB01682A	Carbon Resistor 6.8K ERD-25T J
R668,669	OB05621A	Carbon Resistor 120K ERD-25T J
R687	OB05575A	Carbon Resistor 560 ERD-25T J
C101,201 504,508 509,522 523,542	OB01405A	Electrolytic Capacitor 1μ 50V
C501	OB01402A	Electrolytic Capacitor 4.7μ 25V
C502,503	OB09147A	Electrolytic Capacitor 3.3μ 25V (LN)
C505	OB09333A	Electrolytic Capacitor 4.7μ 25V (LN)
C506,530 531,543 544	OB05813A	Mylar Capacitor 0.056μ 50V J
C507	OB01502A	Electrolytic Capacitor 330μ 16V
C510	OB05512A	Electrolytic Capacitor 2.2μ 16V
C511,512 515	OB05652A	Mylar Capacitor 4700P 50V J
C516	OB05583A	Mylar Capacitor 0.033μ 50V J
C517,533	OB01780A	Mylar Capacitor 0.1μ 50V J
C518,528 529	OB09223A	Electrolytic Capacitor 1μ 50V (LN)
C519	OB09395A	Electrolytic Capacitor 0.68μ 50V (LN)
C520,521	OB05681A	Mylar Capacitor 0.01μ 50V J
C524,525	OB01802A	Mylar Capacitor 2200P 50V J
C526,527 534	OB01412A	Electrolytic Capacitor 10μ 16V
C532	OB09332A	Electrolytic Capacitor 2.2μ 25V (LN)
C535,536	OB01400A	Electrolytic Capacitor 100μ 16V
C537	OB09292A	Ceramic Capacitor 0.1μ 50V Z
C538	OB09277A	Ceramic Capacitor 10P 50V J
C539	OB09377A	Electrolytic Capacitor 4700μ 16V
C540,541	OB09285A	Ceramic Capacitor 330P 50V K
C545	OB01862A	Electrolytic Capacitor 22μ 16V
SW501,502 504	OB07323A	Rotary Switch 2-3N
SW503,505	OB07325A	Rotary Switch 2-2N
CN29,30	OBL8178A	12P-T Post
CN31	OBL8644A	8P-T Post
CN32	OBL8643A	7P-T Post
CN33	OBL8646A	10P-T Post
CN34,35	OBL8653A	3P-T Post
CN36	OBL8656A	2P-T Post

1.19. Logic P.C.B. Ass'y

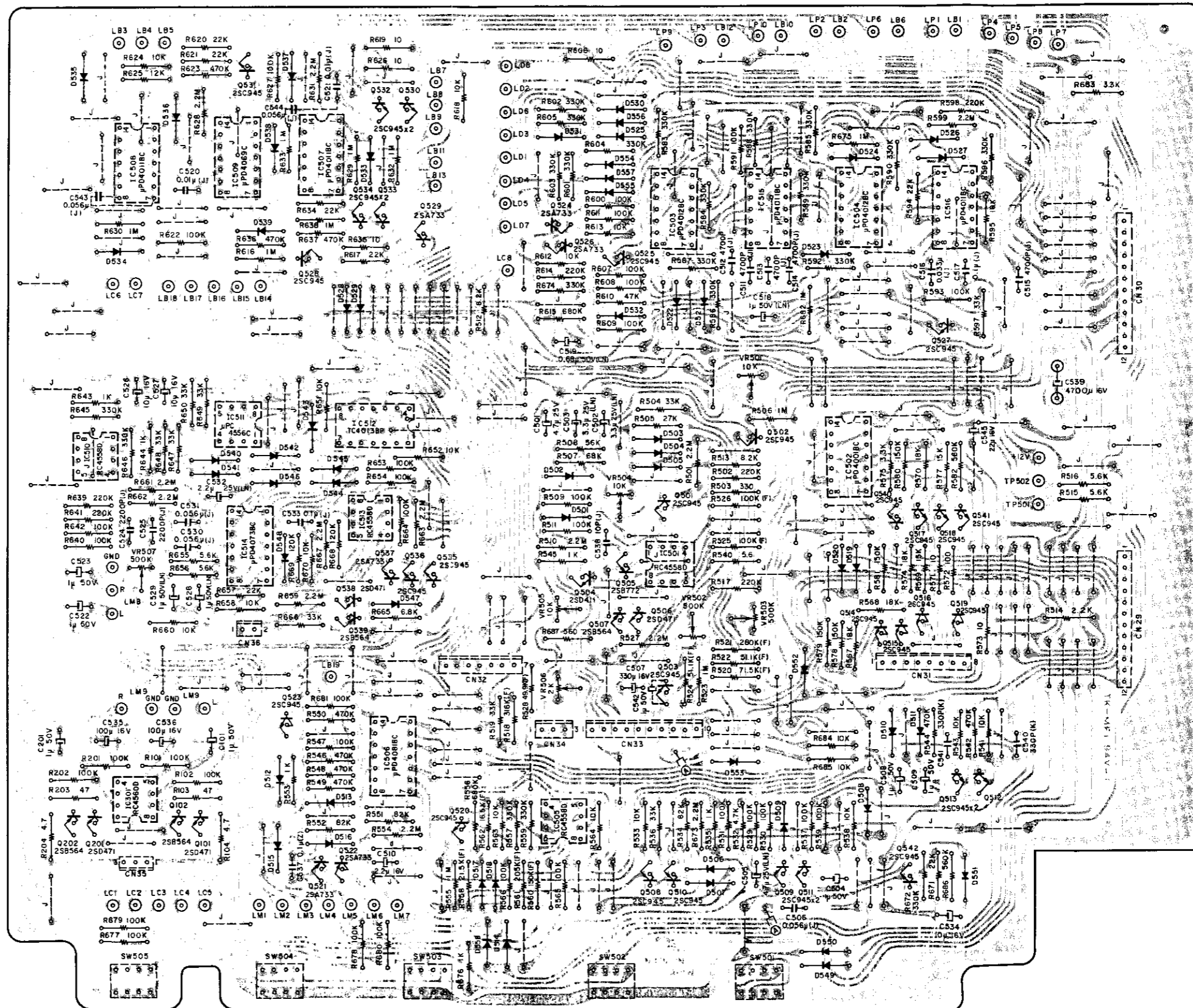

Fig. 1.19

Note: Diode is 1SS53 unless otherwise specified.

1.20. CPU P.C.B. A Ass'y

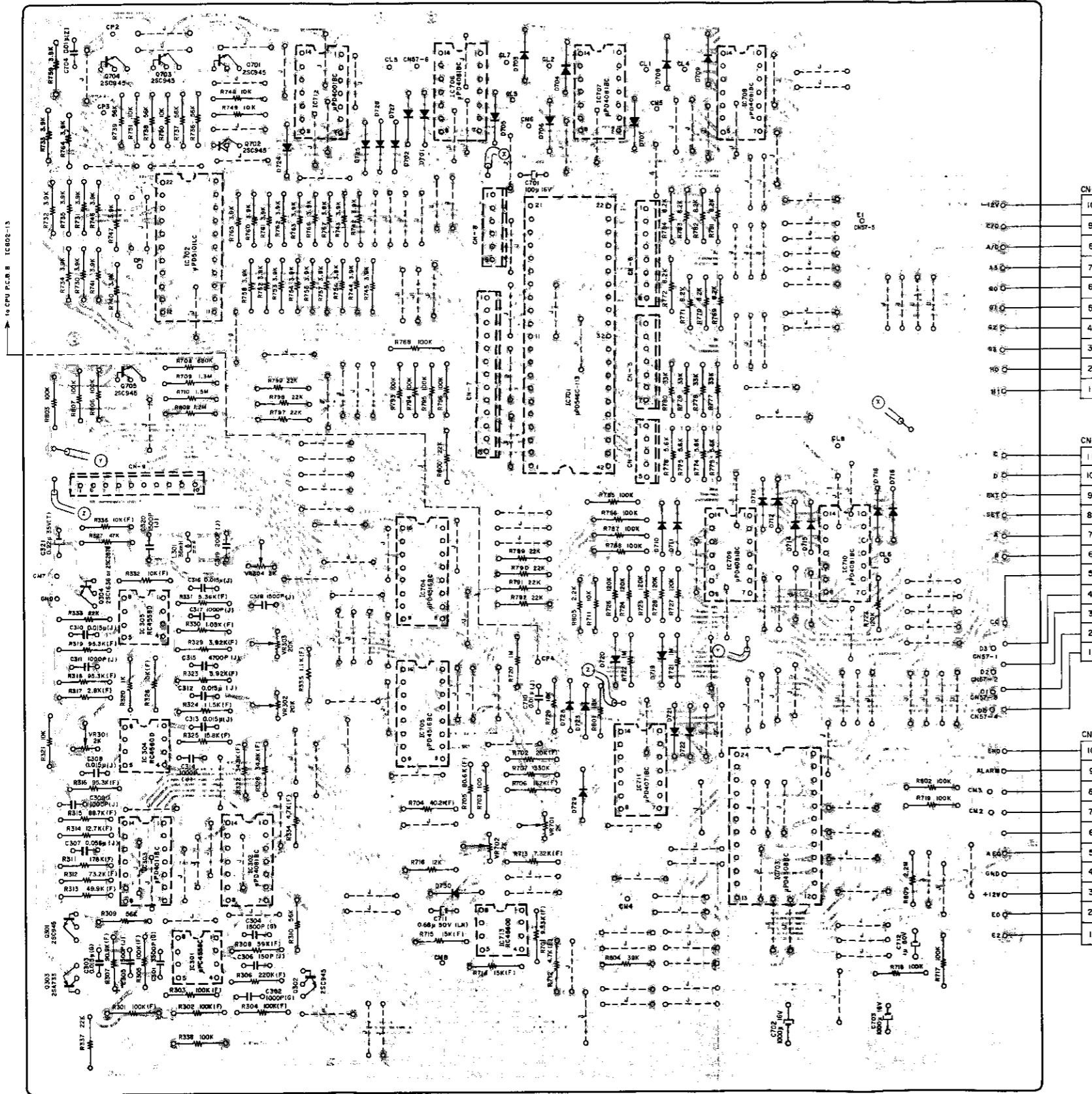

Fig. 1.20

Note: Diode is 1SS53 unless otherwise specified.

Schematic Ref. No.	Part No.	Description
	BAL4228A	CPU P.C.B. A Ass'y
IC301	0B07880B	CPU P.C.B. A
IC302,706	0B06216A	IC μ PC4556C
707,708	0B06219A	IC μ PD4081BC
709,710		
IC303	0B06178A	IC μ PD4011BC
IC304,713	0B06217A	IC RC4560D
IC305	0B06124B	IC RC4558D
IC701	0B06253A	IC A.B.L.E. CPU μ PD546C-113
IC702	0B06265A	IC μ PD5101LC
IC703	0B06261A	IC μ PD4508BC
IC704,705	0B06260A	IC μ PD4516BC
IC711	0B06214A	IC μ PD4071BC
IC712	0B06143A	IC μ PD4001BC
Q301,302	0B06100A	Transistor 2SC945 (A)
701,702		
703,704		
705		
Q303	0B06013A	Transistor 2SA733
Q304	0B06070A	Transistor 2SC1636
	(0B06299A)	(2SC2878)
D701-716	0B06181A	Silicon Diode 1SS53 (29 pcs.)
718-730		
L301	0B03919B	Inductor 36mH
VR301,304	0B07329A	Semi-fixed Volume 2K
701,702		
VR302,303	0B07270A	Semi-fixed Volume 20K
R301,302	0B09305A	Metal Film Resistor 100K SN14K2E F
303,304		
305		
R306	0B09472A	Metal Film Resistor 220K SN14K2E F
R307	0B09461A	Metal Film Resistor 90.9K SN14K2E F
R308	0B09455A	Metal Film Resistor 59K SN14K2E F
R309,310	0B05508A	Carbon Resistor 56K ERD-25T J
736,737		
738,739		
R311	0B09469A	Metal Film Resistor 178K SN14K2E F
R312	0B09458A	Metal Film Resistor 73.2K SN14K2E F
R313	0B09452A	Metal Film Resistor 49.9K SN14K2E F
R314	0B09534A	Metal Film Resistor 12.7K SN14K2E F
R315	0B09460A	Metal Film Resistor 88.7K SN14K2E F
R316,318	0B09462A	Metal Film Resistor 95.3K SN14K2E F
319		
R317	0B09762A	Metal Film Resistor 2.8K SN14K2E F
R320	0B01857A	Carbon Resistor 1K ERD-25T J
R321,711	0B01888A	Carbon Resistor 10K ERD-25T J
748,749		
750,751		
R322,328	0B09447A	Metal Film Resistor 34.8K SN14K2E F
R323,329	0B09768A	Metal Film Resistor 3.92K SN14K2E F
R324	0B09434A	Metal Film Resistor 11.5K SN14K2E F
R325	0B09437A	Metal Film Resistor 15.8K SN14K2E F
R326,332	0B09203A	Metal Film Resistor 10K SN14K2E F
336		
R327	0B05641A	Carbon Resistor 47K ERD-25T J
R330	0B09417A	Metal Film Resistor 1.05K SN14K2E F
R331	0B09426A	Metal Film Resistor 5.36K SN14K2E F
R333,337	0B06615A	Carbon Resistor 22K ERD-25T J
789,790		
791,792		
797,798		
799,800		

Schematic Ref. No.	Part No.	Description	Schematic Ref. No.	Part No.	Description
R334,712	OB09356A	Metal Film Resistor 4.7K SN14K2E F	C704	OB09290A	Ceramic Capacitor 0.01 μ 50V Z
R335	OB09505A	Metal Film Resistor 1.1K SN14K2E F	C710	OB05681A	Mylar Capacitor 0.01 μ 50V J
R338,717	OB01889A	Carbon Resistor 100K ERD-25T J	C711	OB09395A	Electrolytic Capacitor 0.68 μ 50V (LN)
718,719			C712	OB01405A	Electrolytic Capacitor 1 μ 50V
768,785			CN1,3	OBL8760A	10P-H Connector 100mm
786,787			CN2	OBL8761A	11P-H Connector 100mm
788,793			CN4	OBL8183A	5P-T Post
794,795			CN5	OBL8302A	7P-T Post B7P-SHF-1
796,802			CN6	OBL8334A	8P-T Post B8P-SHF-1
803,806			CN7	OBL8506A	13P-T Post
807			CN8	OBL8182A	6P-T Post
R701	OB09522A	Metal Film Resistor 9.53K SN14K2E F	CN9	OBL8615A	10P-T Post
R702	OB09439A	Metal Film Resistor 20K SN14K2E F	CN57	OBL8746A	6P-H Connector 930mm
R703	OB01679A	Carbon Resistor 100 ERD-25T J			
R704	OB09448A	Metal Film Resistor 40.2K SN14K2E F			
R705	OB09459A	Metal Film Resistor 80.6K SN14K2E F			
R706	OB09467A	Metal Film Resistor 162K SN14K2E F			
R707	OB05627A	Carbon Resistor 330K ERD-25T J			
R708	OB09335A	Carbon Resistor 680K ERD-25T J			
R709	OB05963A	Carbon Resistor 1.3M ERD-25T J			
R710	OB09380A	Carbon Resistor 1.5M ERD-25T J			
R713	OB09429A	Metal Film Resistor 7.32K SN14K2E F			
R714,715	OB09340A	Metal Film Resistor 15K SN14K2E F			
R716	OB09263A	Carbon Resistor 12K ERD-25T J			
R720,721	OB05776A	Carbon Resistor 1M ERD-25T J			
722					
R723,724	OB05621A	Carbon Resistor 120K ERD-25T J			
725,726					
727,728					
R729,801	OB05560A	Carbon Resistor 18K ERD-25T J			
R730-735	OB05675A	Carbon Resistor 3.9K ERD-25T J (30 pcs.)			
740-747					
752-767					
R769,770	OB01856A	Carbon Resistor 8.2K ERD-25T J			
771,772					
781,782					
783,784					
R773,774	OB01887A	Carbon Resistor 5.6K ERD-25T J			
775,776					
R777,778	OB05509A	Carbon Resistor 33K ERD-25T J			
779,780					
R804	OB01854A	Carbon Resistor 39K ERD-25T J			
R805	OB05622A	Carbon Resistor 2.2K ERD-25T J			
R808	OB05962A	Carbon Resistor 1.2M ERD-25T J			
R809	OB05671A	Carbon Resistor 2.2M ERD-25T J			
C301	OB09411A	PP Capacitor 3300P 100V G			
C302	OB09408A	PP Capacitor 1000P 50V G			
C303	OB05950A	PP Capacitor 0.015 μ 100V G			
C304	OB09409A	PP Capacitor 1800P 100V G			
C305,318	OB05653A	Mylar Capacitor 1500P 50V J			
320					
C306	OB09246A	Mica Capacitor 150P 50V J			
C307	OB05813A	Mylar Capacitor 0.056 μ 50V J			
C308,310	OB05557A	Mylar Capacitor 0.015 μ 50V J			
312,313					
316					
C309,311	OB05550A	Mylar Capacitor 1000P 50V J			
314,317					
C315	OB05652A	Mylar Capacitor 4700P 50V J			
C319	OB09275A	Mica Capacitor 200P 50V J			
C321	OB09361A	Tantalum Capacitor 0.22 μ 35V			
C701	OB01400A	Electrolytic Capacitor 100 μ 16V			
C702,703	OB01397A	Electrolytic Capacitor 1000 μ 16V			

Schematic Ref. No.	Part No.	Description	Schematic Ref. No.	Part No.	Description
	BAL4229A	CPU P.C.B. B Ass'y	R124,224	0B05579A	Carbon Resistor 22 ERD-25T J
			R125,225	0B05936A	Carbon Resistor 10 ERD-25T J
			R823,824	0B09305A	Metal Film Resistor 100K SN14K2E F
			R825	0B09481A	Metal Film Resistor 536K SN14K2E F
			R826,853	0B05776A	Carbon Resistor 1M ERD-25T J
			880		
			R828,834	0B09216A	Fail Safe Type Resistor 10 RDF-25S J
			835,836		
			837,872		
			873,874		
			875,876		
			877		
			R829-833	0B01854A	Carbon Resistor 39K ERD-25T J
			850		(18 pcs.)
			857-868		
			R849,851	0B01889A	Carbon Resistor 100K ERD-25T J
			852,855		
			902		
			R854,870	0B01682A	Carbon Resistor 6.8K ERD-25T J
			871,886		
			R878,900	0B05671A	Carbon Resistor 2.2M ERD-25T J
			901		
			R879	0B05625A	Carbon Resistor 220K ERD-25T J
			R881	0B05676A	Carbon Resistor 390K ERD-25T J
			R882,885	0B01846A	Carbon Resistor 4.7K ERD-25T J
			R883,887	0B01857A	Carbon Resistor 1K ERD-25T J
			R884,888	0B01713A	Carbon Resistor 33 ERD-25T J
			R889	0B09536A	Fail Safe Type Resistor 18 RSF-1/2B J
			R890	0B09537A	Fail Safe Type Resistor 22 RSF-1/2B J
			R895,896	0B01933A	Carbon Resistor 220 ERD-25T J
			R897	0B01888A	Carbon Resistor 10K ERD-25T J
			R898	0B05627A	Carbon Resistor 330K ERD-25T J
			R899	0B09531A	Carbon Resistor 2M ERD-25T J
			C101,201	0B09411A	PP Capacitor 3300P 100V G
			C102,202	0B09410A	PP Capacitor 2200P 100V G
			C103,203	0B09405A	PP Capacitor 0.022μ 100V G
			C104,204	0B09404A	PP Capacitor 1000P 100V J
			C105,107	0B09322A	PP Capacitor 330P 100V J
			205,207		
			C106,206	0B09246A	Mica Capacitor 150P 50V J
			C801,802	0B09222A	Electrolytic Capacitor 0.47μ 50V (LN)
			804,805		
			806,807		
			C803	0B05681A	Mylar Capacitor 0.01μ 50V J
			C808	0B09163A	Electrolytic Capacitor 10μ 16V (BP)
			C809	0B09407A	PP Capacitor 0.15μ 100V J
			C810,811	0B01412A	Electrolytic Capacitor 10μ 16V
			C812,813	0B01502A	Electrolytic Capacitor 330μ 16V
			814,815		
			C816	0B01405A	Electrolytic Capacitor 1μ 50V
			C817	0B01780A	Mylar Capacitor 0.1μ 50V J
			CN1,3	OBL8646A	10P-T Post
			CN2	OBL8655A	11P-T Post
			CN15	OBL8642A	6P-T Post
			CN16	OBL8643A	7P-T Post
			CN17	OBL8724A	5P-T Post
			CN18	OBL8656A	2P-T Post
			CN19	OBL8654A	4P-T Post
			CN20	OBL8645A	9P-T Post
			CN51	OBL8757A	8P-H Connector 250mm
			CN52	OBL8756A	4P-H Connector 180mm
			CN54	OBL8758A	3P-H Connector 850mm
IC101,201	0B07881C	CPU P.C.B.			
802	0B06261A	IC μPD4508BC			
IC301	0B06216A	IC μPC4556C			
IC801	0B06264A	IC TC4514BP			
IC803,808	0B06178A	IC μPD4011BC			
IC804	0B06143A	IC μPD4001BC			
IC805	0B06124B	IC RC4558D			
IC806	0B06223A	IC μPD4040BC			
IC807	0B06270A	IC μPD4069C			
IC809	0B06219A	IC μPD4081BC			
Q101,201	0B06100A	Transistor 2SC945 (A)			
801-807		(18 pcs.)			
813-818					
830,831					
832					
Q102,202	0B06179A	Transistor 2SC1959 (Y)			
822					
Q103,203	0B06202A	Transistor 2SA562 (Y)			
819					
Q808-812	0B06013A	Transistor 2SA733 (6 pcs.)			
821					
Q820	0B06069A	Transistor 2SB564			
Q823	0B06066A	Transistor 2SD471			
D801-815	0B06181A	Silicon Diode 1SS53 (15 pcs.)			
X801	0B08723A	Crystal 1.68MHz			
L101,201	0B01434A	Peaking Coil 1.14mH			
L102,202	0B06635A	Bias Coil			
L103,203	0B00068A	Trap Coil 10.5mH			
VR101,201	0B07256A	Semi-fixed Volume 10K			
VR801	0B07330A	Semi-fixed Volume 500K			
R101,102	0B05621A	Carbon Resistor 120K ERD-25T J			
201,202		(42 pcs.)			
801-822					
827					
838-846					
848,869					
891-894					
R103,203	0B09435A	Metal Film Resistor 12.1K SN14K2E F			
R104,204	0B09467A	Metal Film Resistor 162K SN14K2E F			
R105,205	0B09475A	Metal Film Resistor 316K SN14K2E F			
R106,206	0B09482A	Metal Film Resistor 649K SN14K2E F			
R107,207	0B05962A	Carbon Resistor 1.2M ERD-25T J			
R108,208	0B09535A	Metal Film Resistor 9.76K SN14K2E F			
R109,209	0B09439A	Metal Film Resistor 20K SN14K2E F			
R110,210	0B09448A	Metal Film Resistor 40.2K SN14K2E F			
R111,211	0B09459A	Metal Film Resistor 80.6K SN14K2E F			
R112,212	0B09429A	Metal Film Resistor 7.32K SN14K2E F			
R113,114	0B09263A	Carbon Resistor 12K ERD-25T J			
115,116					
119,213					
214,215					
216,219					
847,856					
R117,120	0B05615A	Carbon Resistor 22K ERD-25T J			
217,220					
R118,218	0B01683A	Carbon Resistor 15K ERD-25T J			
R121,221	0B05629A	Carbon Resistor 2.7K ERD-25T J			
R122,222	0B05575A	Carbon Resistor 560 ERD-25T J			
R123,223	0B09425A	Metal Film Resistor 5.11K SN14K2E F			

1.21. CPU P.C.B. B Ass'y

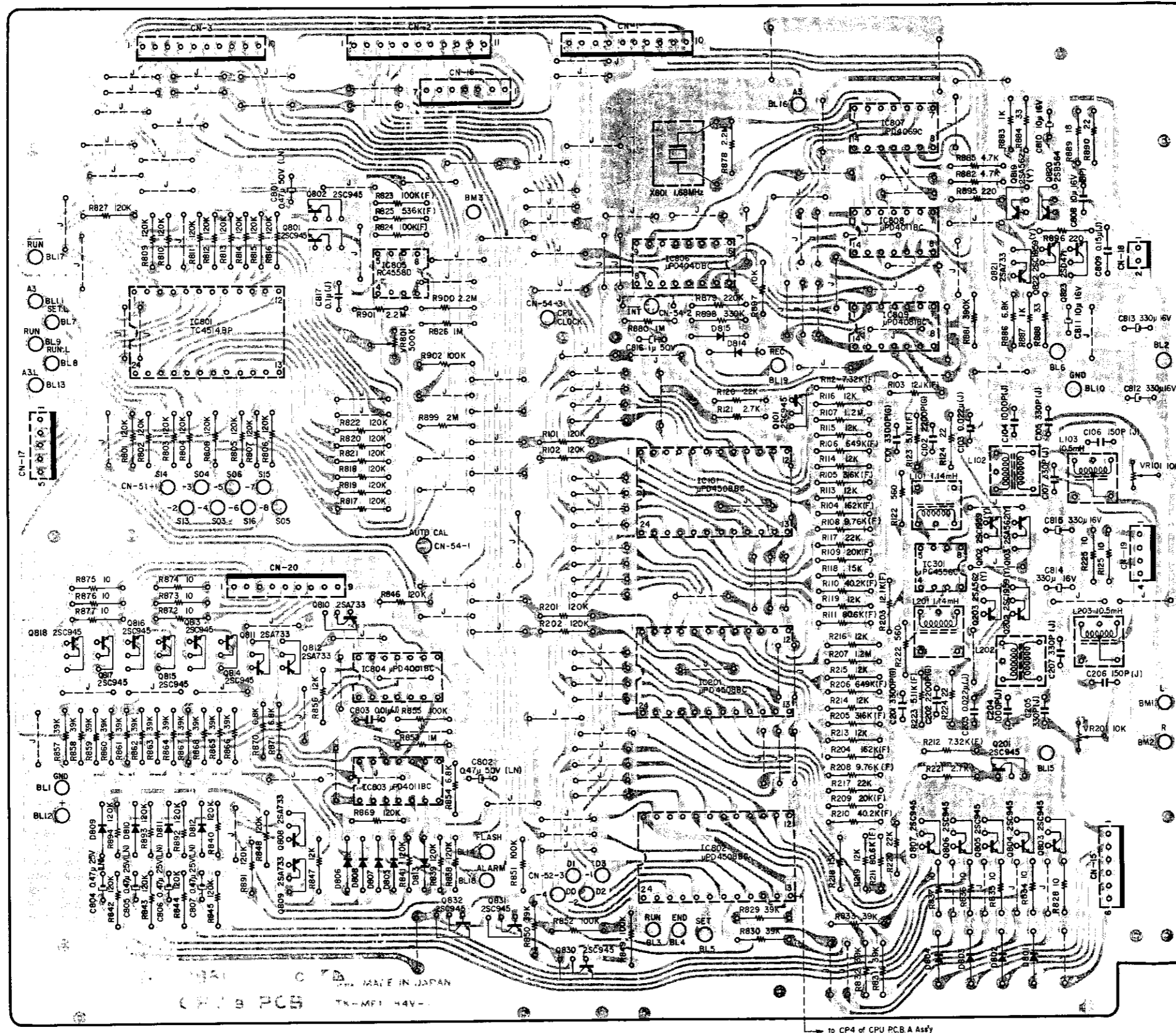

Fig. 1.21

Note: Diode is 1SS53 unless otherwise specified.

1.22. RAMM P.C.B. Ass'y

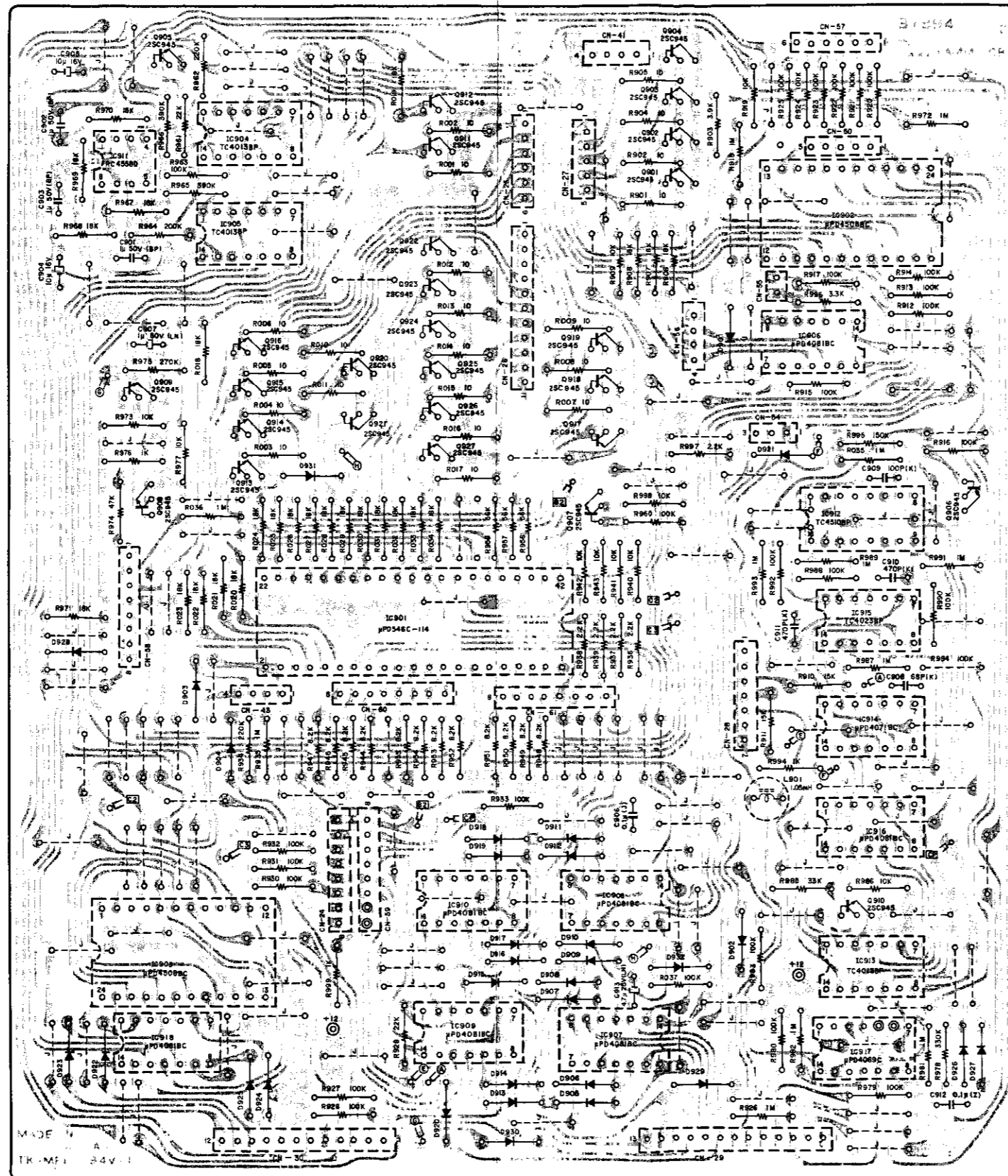

Fig. 1.22 Note: Diode is 1SS53 unless otherwise specified.

Schematic Ref. No.	Part No.	Description	Schematic Ref. No.	Part No.	Description
	BAL4226A	RAMM P.C.B. Ass'y	R995	OB05626A	Carbon Resistor 150K ERD-25T J
	OB07894D	RAMM P.C.B.	R996	OB01681A	Carbon Resistor 3.3K ERD-25T J
IC901	OB06245A	IC RAMM CPU μ PD546C-114	C901,902	OB09187A	Electrolytic Capacitor 1 μ 50V (BP)
IC902,903	OB06261A	IC μ PD4508BC	903		
IC904,905	OB06213A	IC TC4013BP	C904,905	OB01412A	Electrolytic Capacitor 10 μ 16V
913			C906	OB01780A	Mylar Capacitor 0.1 μ 50V J
IC906-910	OB06219A	IC μ PD4081BC (7 pcs.)	C907	OB09223A	Electrolytic Capacitor 1 μ 50V (LN)
916,918			C908	OB09393A	Ceramic Capacitor 68P 50V K
IC911	OB06124B	IC RC4558D	C909	OB09282A	Ceramic Capacitor 100P 50V K
IC912	OB06212A	IC TC4510BP	C910,911	OB09286A	Ceramic Capacitor 470P 50V K
IC914	OB06214A	IC μ PD4071BC	C912	OB09292A	Ceramic Capacitor 0.1 μ 50V Z
IC915	OB06224A	IC TC4023BP	C913	OB09333A	Electrolytic Capacitor 4.7 μ 25V (LN)
IC917	OB06270A	IC μ PD4069C	CN24,58	OBL8644A	8P-T Post
Q901-927	OB06100A	Transistor 2SC945 (A) (27 pcs.)	59		
D901-932	OB06181A	Silicon Diode 1SS53 (32 pcs.)	CN25,57	OBL8642A	6P-T Post
L901	OB06636A	Inductor 1.05mH	CN26	OBL8655A	11P-T Post
R901,902	OB09216A	Fail Safe Type Resistor 10 RDF-25S J (21 pcs.)	CN27	OBL8724A	5P-T Post
904,905			CN28	OBL8643A	7P-T Post
001-017			CN29,30	OBL8732A	12P-S Connector F12P-SHVQ
R903	OB05675A	Carbon Resistor 3.9K ERD-25T J	CN41,56	OBL8654A	4P-T Post
R906-908	OB05560A	Carbon Resistor 18K ERD-25T J (25 pcs.)	CN43	OBL8236A	4P-T Post B4P-SHF-1
967-971			CN50	OBL8183A	5P-T Post B5P-SHF-1
018-034			CN54	OBL8653A	3P-T Post
R909,919	OB01888A	Carbon Resistor 10K ERD-25T J	CN55	OBL8656A	2P-T Post
940,941			CN60,61	OBL8334A	8P-T Post B8P-SHF-1
942,943					
973,977					
986,998					
R910,911	OB01683A	Carbon Resistor 15K ERD-25T J			
R912-917	OB01889A	Carbon Resistor 100K ERD-25T J (28 pcs.)			
920-925					
927,928					
930-933					
960,963					
979,980					
983,984					
988,990					
992,037					
R918,926	OB05776A	Carbon Resistor 1M ERD-25T J			
935,972					
981,982					
987,989					
991,993					
035,036					
R929,961	OB05615A	Carbon Resistor 22K ERD-25T J			
R934,962	OB05625A	Carbon Resistor 220K ERD-25T J			
R936,937	OB05622A	Carbon Resistor 2.2K ERD-25T J			
938,939					
997					
R944-955	OB01856A	Carbon Resistor 8.2K ERD-25T J (12 pcs.)			
R956,957	OB05508A	Carbon Resistor 56K ERD-25T J			
958					
R964	OB09392A	Carbon Resistor 200K ERD-25T J			
R965,966	OB05676A	Carbon Resistor 390K ERD-25T J			
R974	OB05641A	Carbon Resistor 47K ERD-25T J			
R975	OB05620A	Carbon Resistor 270K ERD-25T J			
R976,994	OB01857A	Carbon Resistor 1K ERD-25T J			
999					
R978	OB05627A	Carbon Resistor 330K ERD-25T J			
R985	OB05509A	Carbon Resistor 33K ERD-25T J			

1.23. Display P.C.B. Ass'y

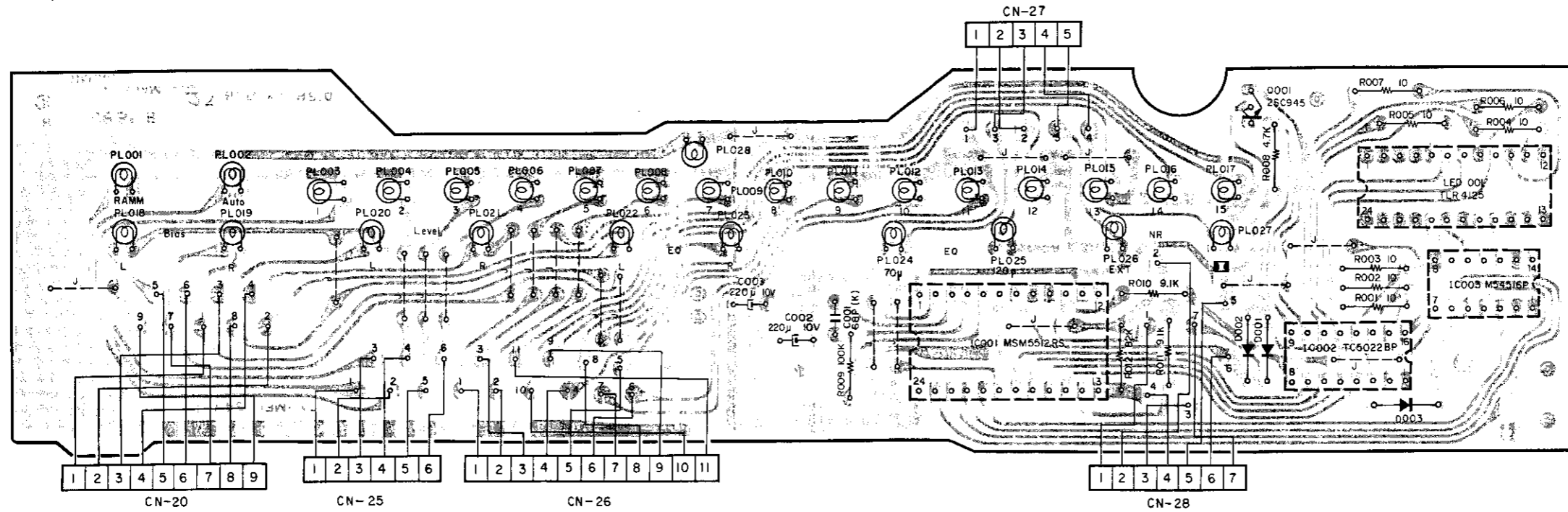

Fig. 1.23

Note: Diode is 1SS53 unless otherwise specified.

Schematic Ref. No.	Part No.	Description
	BAL4233A	Display P.C.B. Ass'y
	0B07883B	Display P.C.B.
IC001	0B06259A	IC MSM5512RS
IC002	0B06211A	IC TC5022BP
IC003	0B06258A	IC M54516P
Q001	0B06100A	Transistor 2SC945 (A)
D001,002 D003	0B06181A	Silicon Diode 1SS53
LE001	0B06266A	LED TLR4125
R001-007	0B05936A	Carbon Resistor 10 ERD-25T J (7 pcs.)
R008	0B01846A	Carbon Resistor 4.7K ERD-25T J
R009	0B01889A	Carbon Resistor 100K ERD-25T J
R010,011	0B05694A	Carbon Resistor 9.1K ERD-25T J
R012	0B05668A	Carbon Resistor 82K ERD-25T J
C001	0B09393A	Ceramic Capacitor 68P 50V K
C002,003	0B05899A	Electrolytic Capacitor 22μ 10V
PL001-027	0B08721A	Lamp 12V 30mA (27 pcs.)
PL028	0B08822A	Lamp 14V 60mA
CN20	0BL8741A	9P-H Connector 550mm
CN25	0BL8740A	6P-H Connector 340mm
CN26	0BL8742A	11P-H Connector 360mm
CN27	0BL8738C	5P-H Connector 390mm
CN28	0BL8739A	7P-H Connector 420mm
	0B08772A	Filter Cap (1 pce.)

2. MECHANISM ASS'Y AND PARTS LIST

2.1. Synthesis

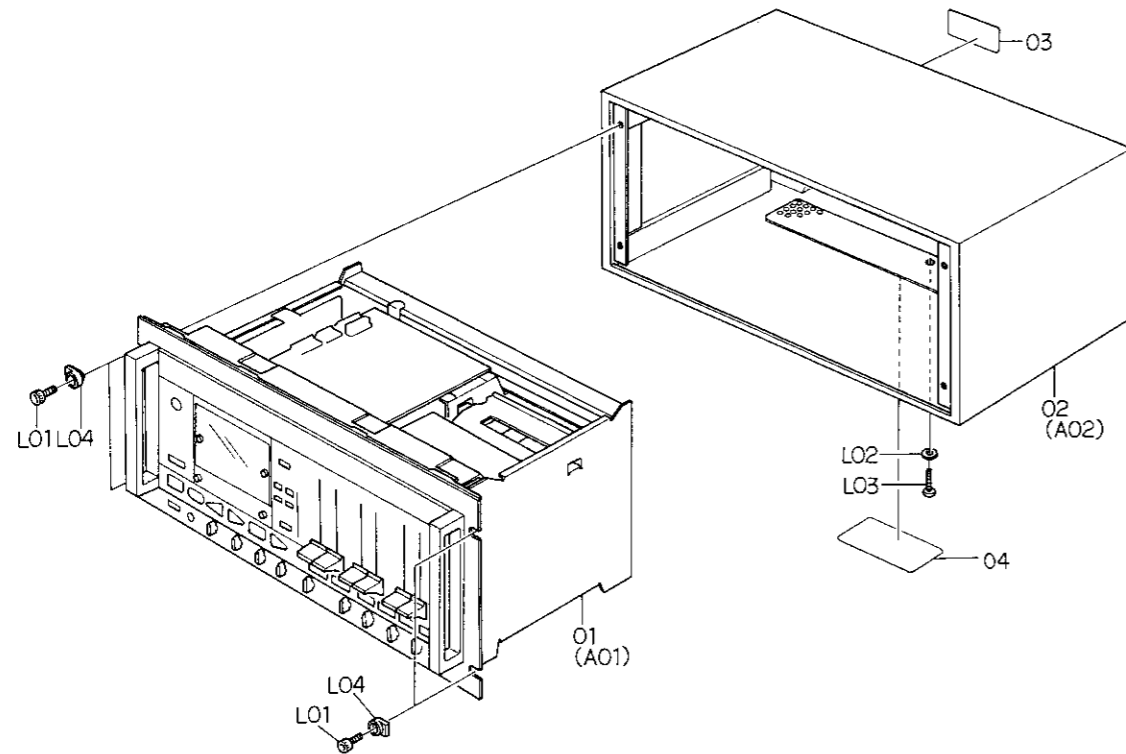

Fig. 2.1

2.2. Synthesis Mechanism Ass'y (A01)

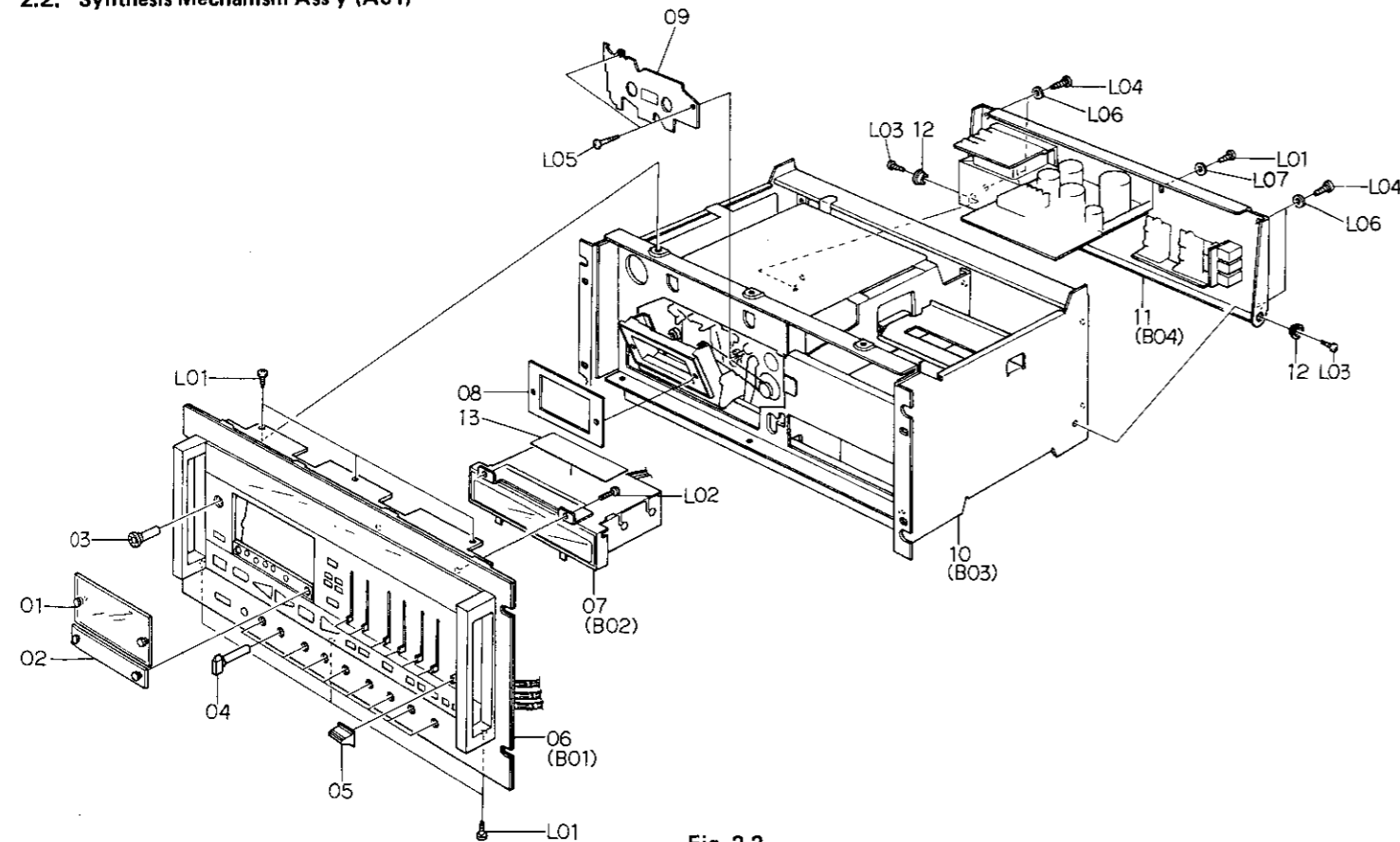

Fig. 2.2

Schematic Ref. No.	Part No.	Description	Q'ty	Schematic Ref. No.	Part No.	Description	Q'ty
		Synthesis		A01	HAL4008A	Synthesis Mechanism Ass'y (U.S.A. & Canada)	1
01	HAL4008A	Synthesis Mechanism Ass'y (U.S.A. & Canada)	1		HAL4025A	Synthesis Mechanism Ass'y (Japan)	1
	HAL4025A	Synthesis Mechanism Ass'y (Japan)	1		HAL4026A	Synthesis Mechanism Ass'y (Others)	1
	HAL4026A	Synthesis Mechanism Ass'y (Others)	1		HAL4027A	Synthesis Mechanism Ass'y (220V Class 2)	1
	HAL4027A	Synthesis Mechanism Ass'y (220V Class 2)	1		HAL4028A	Synthesis Mechanism Ass'y (UK)	1
	HAL4028A	Synthesis Mechanism Ass'y (UK)	1		HAL4029A	Synthesis Mechanism Ass'y (Australia)	1
	HAL4029A	Synthesis Mechanism Ass'y (Australia)	1	01	HAL4001A	Cassette Case Cover Ass'y	1
02	HA04272A	Cabinet Ass'y	1	02	HA04279A	Owner's Name Plate Ass'y	1
03	OM03458A	PASS Label	1	03	OHL3846A	Pitch Control Knob	1
04	OM04101A	Caution Label	1	04	OHL3860A	Function Switch Knob	9
L01	OH04026A	Screw M5x10 Socket Head	4	05	OHL3844A	Slide Volume Knob	3
L02	OE00930A	Washer 5mm (Black Chromate)	1	06	HAL4009A	Front Panel Ass'y	1
L03	OE00963A	Screw M4x20 Philips Binding Head (Bronze)	1	07	HAL4011A	FL Indicator Ass'y	1
L04	OH04063A	Set Washer	4	08	OHL3838A	Cassette Case Plate	1
				09	CA08259A	Cover Plate Ass'y	1
				10	HAL4012A	Synthesis Mechanism Sub Ass'y (U.S.A. & Canada)	1
					HAL4030A	Synthesis Mechanism Sub Ass'y (Japan)	1
					HAL4031A	Synthesis Mechanism Sub Ass'y (220V Class 2, UK, Australia & Others)	1
				11	HA04274A	Rear Panel Ass'y (U.S.A. & Canada)	1
					HA04273A	Rear Panel Ass'y (Japan)	1
					HA04275A	Rear Panel Ass'y (Others)	1
					HA04276A	Rear Panel Ass'y (220V Class 2)	1
					HA04277A	Rear Panel Ass'y (UK)	1
					HA04278A	Rear Panel Ass'y (Australia)	1
				12	OJ04154A	Rear Panel Collar	2
				13	OM04310A	Check Seal	1
				-	OB08515A	Insu-Lock	5
				L01	OE00860A	BT Screw M3x6 Philips Binding Head (Black Chromate)	9
				L02	OE00588A	Screw M3x8 Philips Pan Head (Bronze)	2
				L03	OE00857A	BT Screw M3x6 Philips Binding Head	2
				L04	OE00858A	BT Screw M4x6 Philips Binding Head (Bronze)	4
				L05	OE00832A	BT Screw M3x14 Philips Pan Head	2
				L06	OE00736A	Washer 4mm Steel (Black Chromate)	4
				L07	OE00597A	Washer 3mm Steel (Black Chromate)	1

2.3. Cabinet Ass'y (A02)

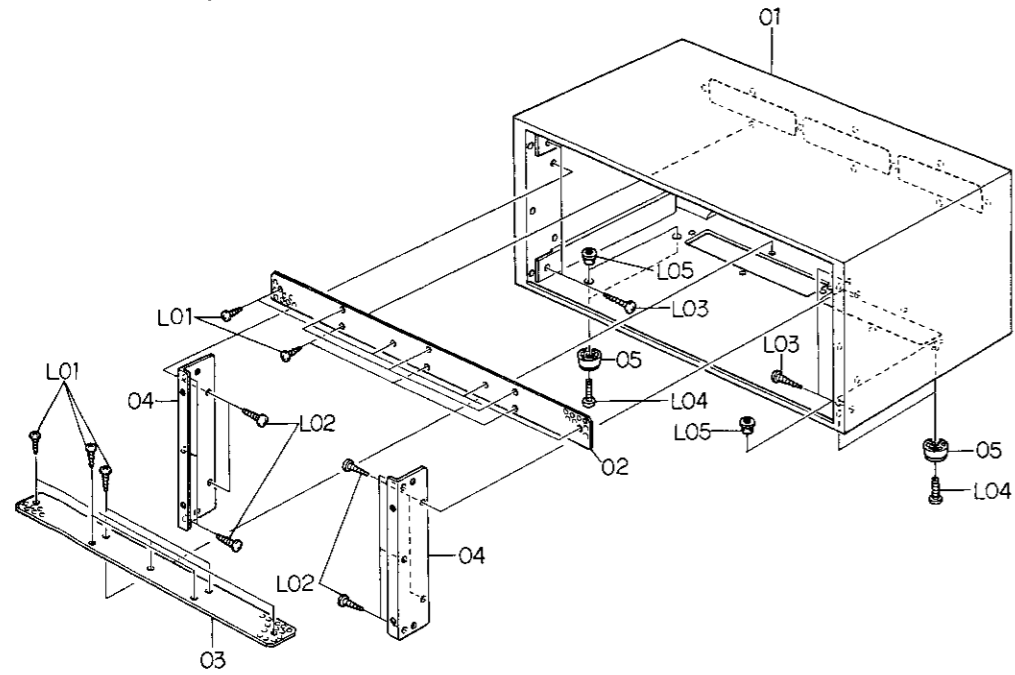

Fig. 2.3

2.4. Front Panel Ass'y (B01)

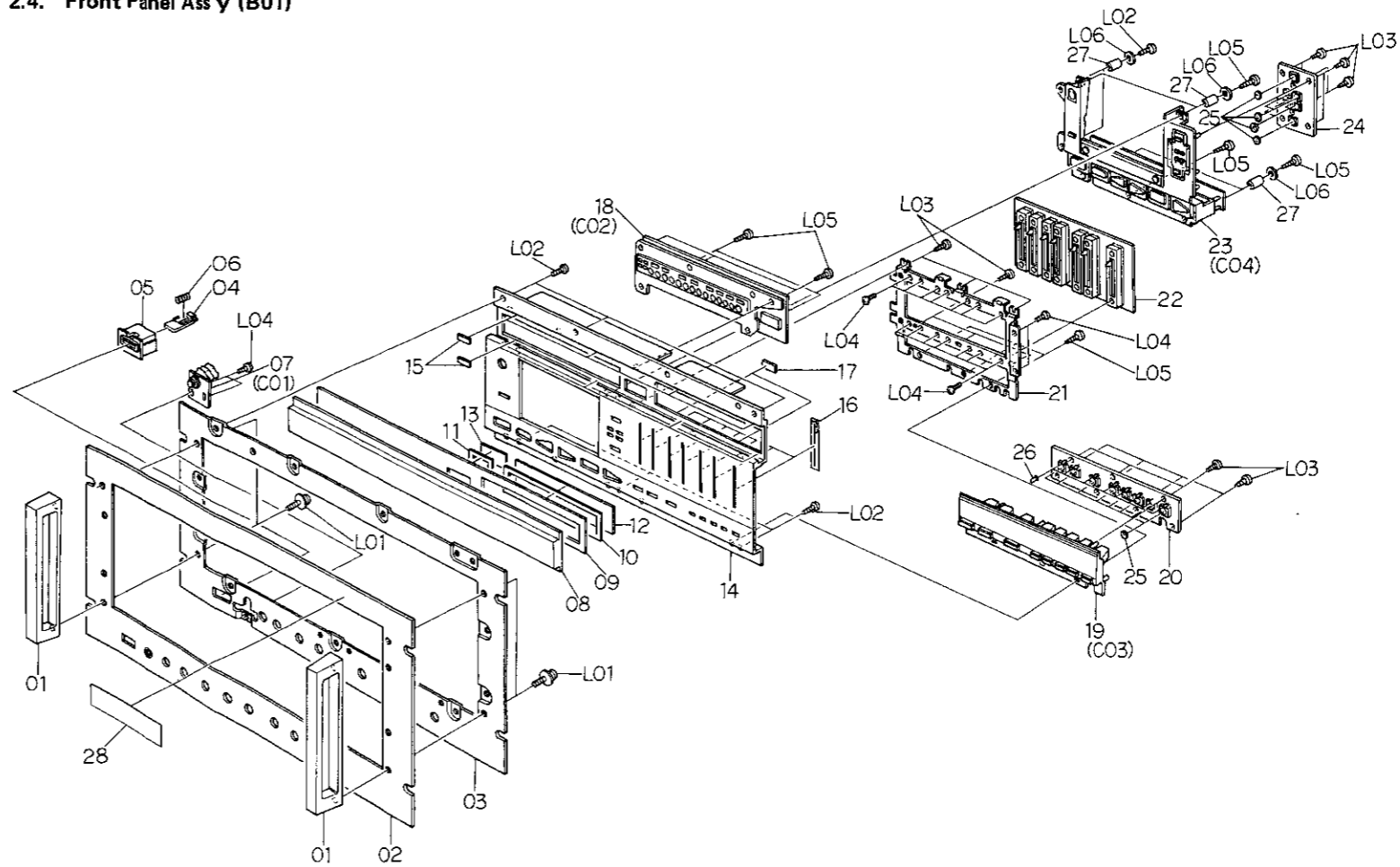

Fig. 2.4

Schematic Ref. No.	Part No.	Description	Q'ty
A02	HA04272A	Cabinet Ass'y	1
01	0A03287A	Cabinet	1
02	0HL3878A	Punching Plate A	1
03	0HL3879A	Punching Plate B	1
04	0HL3880A	Cabinet Side Plate	2
05	0HL3825A	Leg S	4
L01	0E01022A	Wood Screw 2.7x8 Philips Record Head	17
L02	0E01023A	Wood Screw 3.1x13 Philips Round Head	10
L03	0E01024A	Wood Screw 3.1x25 Philips Round Head	4
L04	0E00937A	Screw M4x16 Philips Pan Head (Black Chromate)	4
L05	0E01025A	Nut 4mm (Self Tightened)	4

Schematic Ref. No.	Part No.	Description	Q'ty	Schematic Ref. No.	Part No.	Description	Q'ty
B01	HAL4009A	Front Panel Ass'y	1	20	BAL4240A	Function Switch P.C.B. Ass'y	1
01	0HL3867A	Handle	2	21	0J04118A	Volume Holder	1
02	0HL3871A	Front Panel B	1	22	BAL4232A	MIC Amp. & Volume P.C.B. Ass'y	1
03	0J04121A	Panel Chassis	1	23	HAL4015A	Front Escutcheon A Ass'y	1
04	0HL3863A	Power Switch Button	1	24	BAL4241A	RAMM Control Switch P.C.B. Ass'y	1
05	0H03864A	Power Switch Escutcheon	1	25	0J04290B	Switch Cushion	14
06	0J04114A	Power Switch Spring	1	26	0B08847A	Filter Cap G-50	8
07	JAL3737A	Headphone Jack Ass'y	1	27	0J04329A	Front Escutcheon Collar	6
08	0H03870A	Indicator Cover	1	28	0M04307A	Model Name Plate	1
09	0HL3869B	Indicator Plate	1	-	0J04261A	Black Tape	2
10	0J04288A	Adhesive Tape A	1	L01	0E00933A	Screw M4x12 Philips Pan Head (3A)	4
11	0J04289B	Adhesive Tape B	1	L02	0E00589A	Screw M3x6 Philips Pan Head	18
12	0H03842A	FL Indicator Filter	1	L03	0E00857A	BT Screw M3x6 Philips Binding Head	19
13	0H03856B	Counter Filter	1	L04	0E00502A	Screw M3x5 Philips Pan Head	18
14	0HL3875B	Front Panel	1	L05	0E00868A	BT Screw M3x8 Philips Binding Head	13
15	0J04112B	Indicator Cushion	8	L06	0E00178A	Washer 3mm	6
16	0JL4128A	Volume Cover	7				
17	0J04129A	FL Indicator Cushion	2				
18	HAL4018A	Display House Ass'y	1				
19	HAL4016A	Front Escutcheon B Ass'y	1				

2.5. FL Indicator Ass'y (B02)

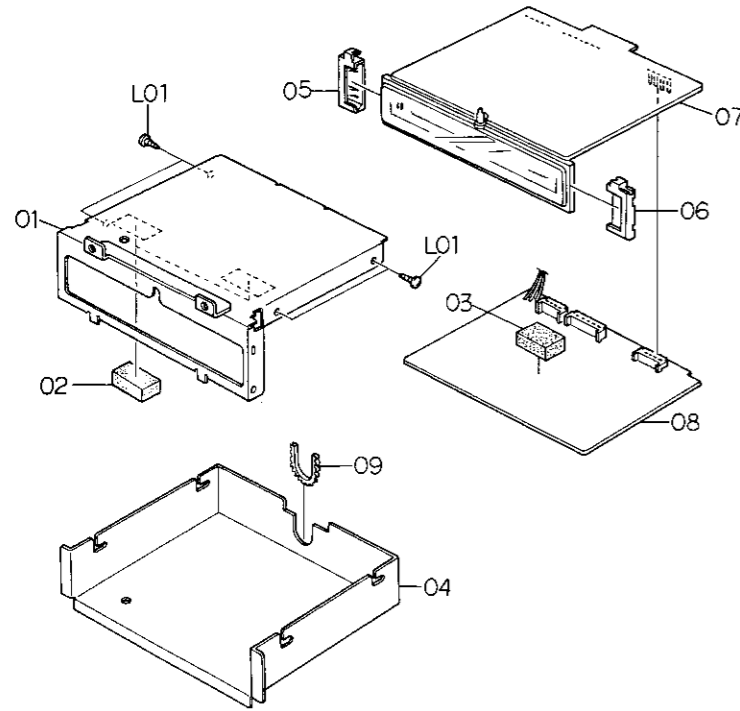

Fig. 2.5

2.6. Synthesis Mechanism Sub Ass'y (B03)

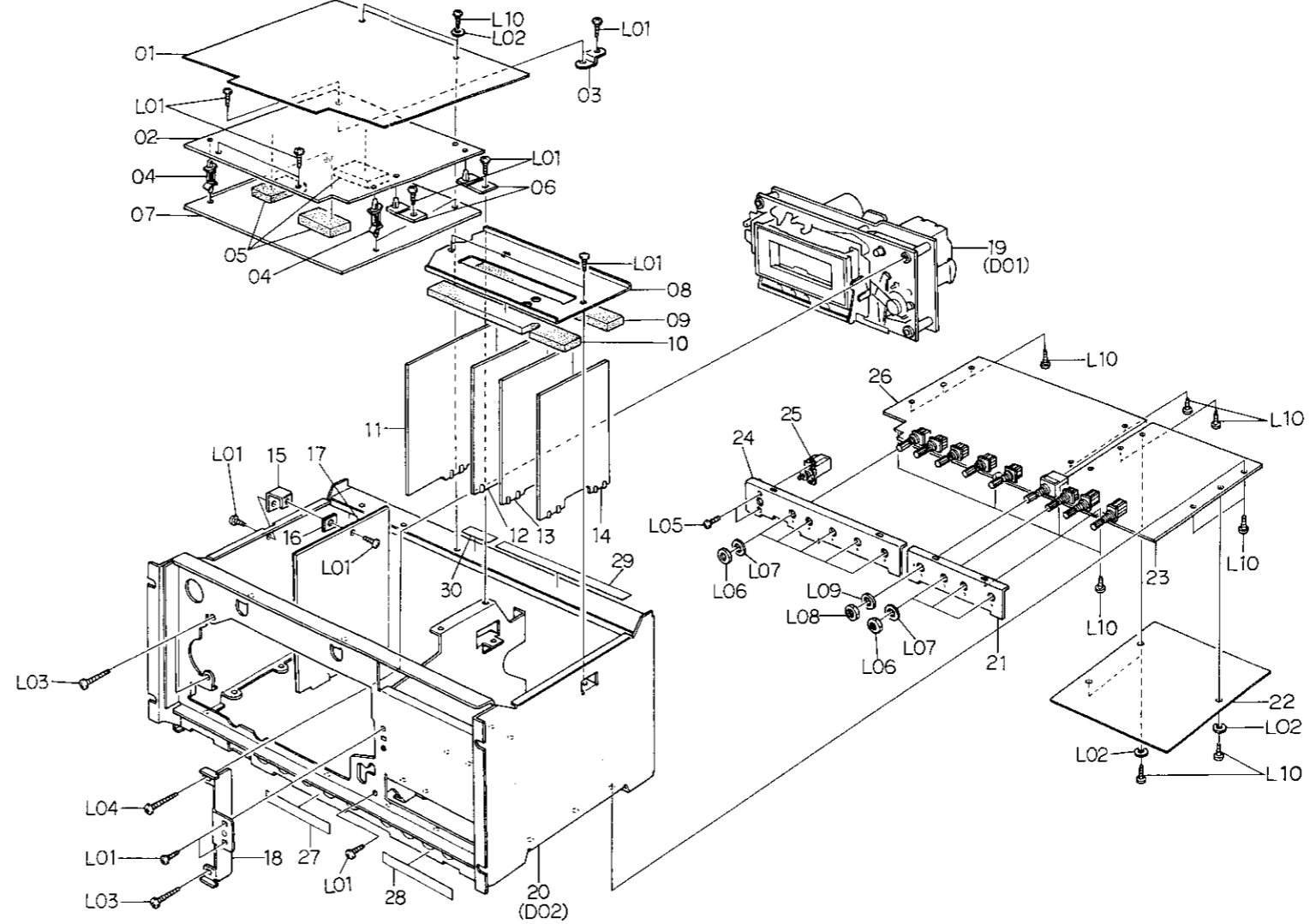

Fig. 2.6

Schematic Ref. No.	Part No.	Description	Q'ty	Schematic Ref. No.	Part No.	Description	Q'ty	Schematic Ref. No.	Part No.	Description	Q'ty	Schematic Ref. No.	Part No.	Description	Q'ty
B02	HAL4011A	FL Indicator Ass'y	1	B03	HAL4012A	Synthesis Mechanism Sub Ass'y (U.S.A. & Canada)	1	12	BAL4230A	Detector P.C.B. Ass'y	1	28	OM04177A	Function Switch Seal R	1
01	JAL3683A	FL Indicator Case Ass'y	1		HAL4030A	Synthesis Mechanism Sub Ass'y (Japan)	1	13	BAL4236A	Record Dolby NR P.C.B. Ass'y	1	29	OM04179A	Module P.C.B. Indicator Label	1
02	OJ04263B	Cushion B	2		HAL4031A	Synthesis Mechanism Sub Ass'y (220V Class 2, UK, Australia & Others)	1	14	BAL4235A	Playback Amp. & Dolby NR P.C.B. Ass'y	1	30	OM04311A	Check Seal	1
03	OJ04262B	Cushion A	1	01	OB08824B	CPU P.C.B. Shield Plate	1	15	OJL4151B	P.C.B. Holder A	1	-	OM04170A	Amplifier Serial No. Seal	1
04	OJL4127A	FL Indicator Case Cover	1	02	BAL4229A	CPU P.C.B. B Ass'y	1	16	OJ04264A	Insulator	1	L01	OB08515A	Insu-Lock	30
05	OJ04119A	FL Indicator Holder L	1	03	OJL4153A	P.C.B. Holder C	1	17	BAL4226A	RAMM P.C.B. Ass'y	1	L02	OE00860A	BT Screw M3x6 Philips Binding Head (Black Chromate)	13
06	OJ04120A	FL Indicator Holder R	1	04	OJ04255A	P.C.B. Supporter	4	18	OJL4135C	Mechanism Bracket	1	L03	OE00178A	Washer 3mm	5
07	BAL4246A	FL Indicator P.C.B. B Ass'y	1	05	OJ04262A	Cushion A	3	19	CA08368A	Mechanism Ass'y 1000ZXL LTD	1	L04	OE00944A	BT Screw M4x15 Philips Binding Head (Black Chromate)	3
08	BAL4245A	FL Indicator P.C.B. A Ass'y	1	06	OB08771A	Hinge	2	20	JAL3734A	Chassis Sub Ass'y	1	L05	OE00924A	BT Screw M4x16 Philips Binding Head	1
09	OB08776A	Free Bushing 36mm	1	07	BAL4228A	CPU P.C.B. A Ass'y	1	22	OB08825A	Main P.C.B. Insulator	1	L06	OE00502A	Screw M3x5 Philips Pan Head	2
L01	OE00860A	BT Screw M3x6 Philips Binding Head (Black Chromate)	4	08	OJL4365A	P.C.B. Holder B	1	23	BAL4227A	Main P.C.B. Ass'y	1	L07	-	Switch Nut A	(8)
				09	OJ04155B	P.C.B. Cushion	1	24	OJL4145A	Switch Plate LB	1	L08	-	Switch Washer A	(8)
				10	OJ04367A	P.C.B. Cushion B	1	25	OB07253A	Power Switch	1	L09	-	Switch Nut B	(1)
				11	BAL4231A	Record Eq. Amp. P.C.B. Ass'y	1	26	OB07271A	Power Switch	1	L10	-	Switch Washer B	(1)
								27	BAL4244B	Logic P.C.B. Ass'y	1		OE00857A	BT Screw M3x6 Philips Binding Head	16
									OM04178A	Function Switch Seal L	1				

2.7. Rear Panel Ass'y (B04)

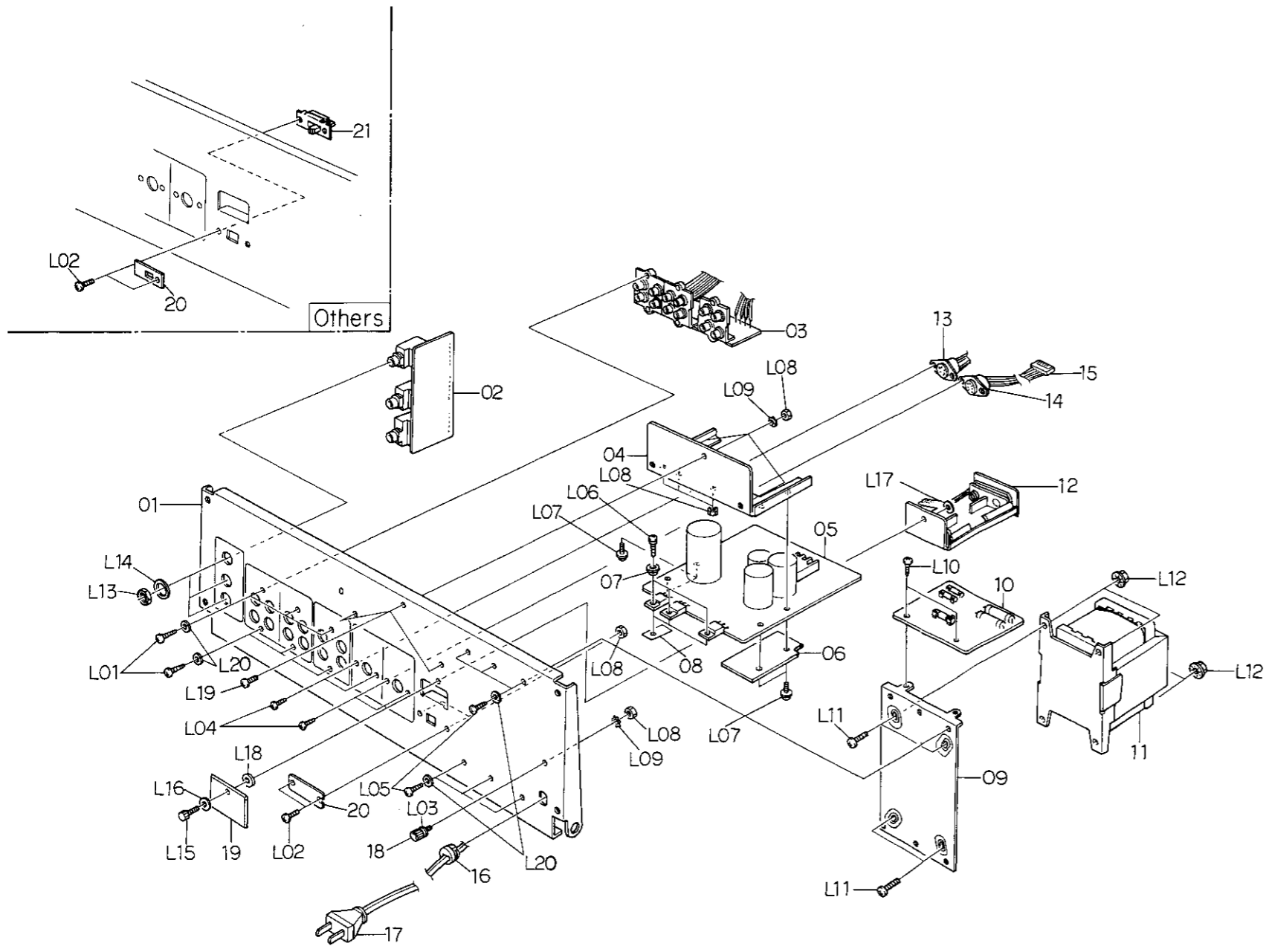

Fig. 2.7

2.8. Headphone Jack Ass'y (C01)

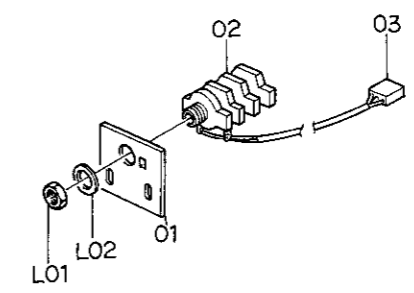

Fig. 2.8

2.9. Display House Ass'y (C02)

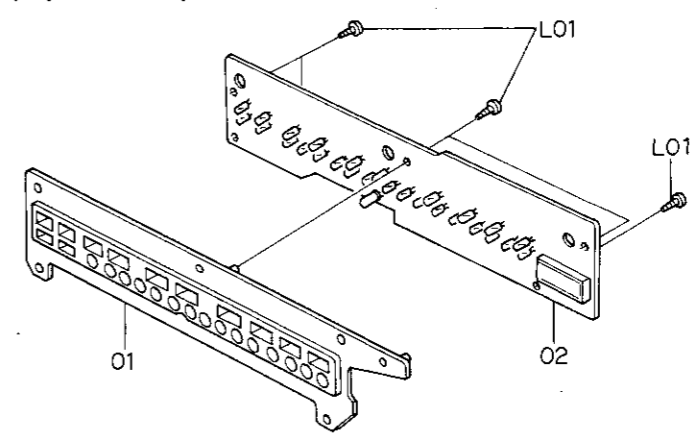

Fig. 2.9

2.10. Front Escutcheon B Ass'y (C03)

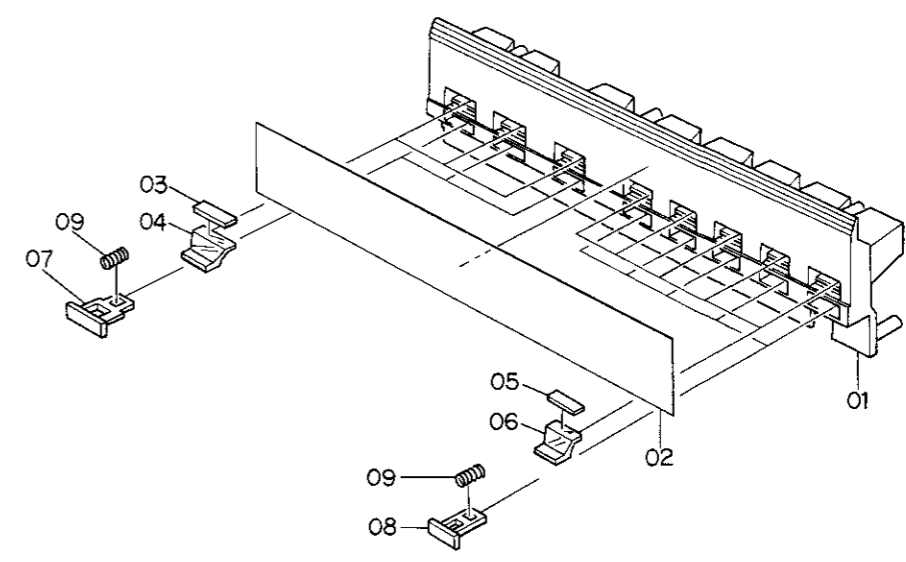

Fig. 2.10

Schematic Ref. No.	Part No.	Description	Q'ty	Schematic Ref. No.	Part No.	Description	Q'ty	
B04	HA04274A	Rear Panel Ass'y (U.S.A. & Canada)	1	L02	0E00593A	Screw M3x6 Philips Binding Head	2	
	HA04273A	Rear Panel Ass'y (Japan)	1	L03	0E00732A	Washer 3mm	1	
	HA04275A	Rear Panel Ass'y (Others)	1	L04	0E00714A	Screw M2.6x6 Philips Binding Head (Bronze)	4	
	HA04276A	Rear Panel Ass'y (220V Class 2)	1	L05	0E00860A	BT Screw M3x6 Philips Binding Head (Bronze)	6	
	HA04277A	Rear Panel Ass'y (UK)	1	L06	0E00510A	Screw M3x8 Philips Pan Head	3	
	HA04278A	Rear Panel Ass'y (Australia)	1	L07	0E00606A	Screw M3x6 Philips Pan Head	4	
01	OHL3881D	Rear Panel	1	L08	0E00507A	Nut Hex. M3	9	
02	BAL4243A	MIC Jack P.C.B. Ass'y	1	L09	0E00172A	Washer 3mm Toothed Lock	4	
03	BA04242A	Pin Jack P.C.B. Ass'y	1	L10	0E00857A	BT Screw M3x6 Philips Binding Head	2	
04	OBL8759D	Heat Sink	1	L11	0E00929A	Screw M4x8 Philips Binding Head	4	
05	BAL4234A	Power Supply P.C.B. Ass'y	1	L12	0E00928A	Nut Hex. M4 Flange	4	
06	OB08826B	Insulator	1	L13	-	MIC Jack Nut	(3)	
07	OB08602A	Transistor Bushing TO220	3	L14	-	MIC Jack Washer	(3)	
08	OB08601A	Insulator Mica TO220	3	L15	OHL3825B	Screw M3x5 Cylinder Head	1	
09	OJ04147B	Transformer Holder	1	L16	OHL3760B	Washer A	1	
10	BA04256A	Fuse P.C.B. Ass'y (U.S.A. & Canada)	1	L17	OJ04067A	Washer FT40	1	
	BA04257A	Fuse P.C.B. Ass'y (Japan)	1	L18	0E00157A	Washer 3mm (Black Plastics)	1	
	BA04371A	Fuse P.C.B. Ass'y (Others)	1	L19	0E00594A	Screw M3x8 Philips Binding Head (Bronze)	3	
	BA04259A	Fuse P.C.B. Ass'y (220V Class 2)	1	L20	0E00597A	Washer 3mm Steel (Black Chromate)	12	
	BA04258A	Fuse P.C.B. Ass'y (UK & Australia)	1					
11	OB06630A	Power Transformer (U.S.A. & Canada)	1	C01	JAL3737A	Headphone Jack Ass'y	1	
	OB06631A	Power Transformer (Japan)	1	01	OJ04110A	Headphone Jack Holder	1	
	OB06633A	Power Transformer (Others)	1	02	OB08511A	Headphone Jack	1	
	OB06632A	Power Transformer (220V Class 2, UK & Australia)	1	03	OBT8765A	3P-H Connector	1	
12	JAL3733A	Battery Box Ass'y	1	L01	-	Headphone Jack Nut	(1)	
13	OB08584A	8P DIN Socket	1	L02	-	Headphone Jack Washer	(1)	
14	OB08495A	8P DIN Socket	1					
15	OBL8770A	8P-H Connector	1	C02	HAL4018A	Display House Ass'y	1	
16	OB08037U	Cord Bushing (U.S.A., Canada, 220V Class 2, Others, Australia & Japan)	1	01	OH03866B	Display House	1	
	OB08351A	Cord Bushing (UK)	1	L01	BAL4233A	Display P.C.B. Ass'y	1	
17	OB08533A	Power Cord (U.S.A., Canada & Others)	1	L01	0E00857A	BT Screw M3x6 Philips Binding Head	5	
	OB08219B	Power Cord (Japan)	1	C03	HAL4016A	Front Escutcheon B Ass'y	1	
	OB08093U	Power Cord (220V Class 2)	1	01	OH03872B	Front Escutcheon B	1	
	OB08348A	Power Cord (UK)	1	02	OJ04117A	Light Intercepting Reflector	1	
	OB05241A	Power Cord (Australia)	1	03	OH03840A	Filter Blue A	3	
	OB05241A	Power Cord (Australia)	1	04	OH03849B	Indicator B	3	
	OBL3920B	Ground Terminal	1	05	OH03841A	Filter Blue B	5	
	18	OHL3882A	Battery Cover	1	06	OH03848B	Indicator A	5
	19	OHL3882A	Battery Cover	1	07	OHL3862A	Function Button B	3
	20	OJL3663C	Switch Cover C (U.S.A., Canada, 220V Class 2, Australia & Japan)	1	08	OHL3861A	Function Button A	5
	OM03946A	Voltage Lock Plate (Others)	1	09	OJ04115B	Function Switch Spring	8	
21	OB07092U	Voltage Selector	1					
-	OM03955A	Voltage Label B (Others)	1					
-	OM03794A	Voltage Label 100V (Japan)	1					
-	OM03796A	Voltage Label 220V (220V Class 2)	1					
-	OM03797A	Voltage Label 240V (UK & Australia)	1					
-	OM03798A	Nakamichi Label (Japan)	1					
-	OM03844B	Power Cord Label (UK)	1					
-	OF01071A	Free-up Belt	1					
-	OM04203A	ABLE Label (U.S.A.)	1					
L01	0E00921A	BT Screw M3x8 Philips Binding Head (Black Chromate)	6					

2.11. Front Escutcheon A Ass'y (C04)

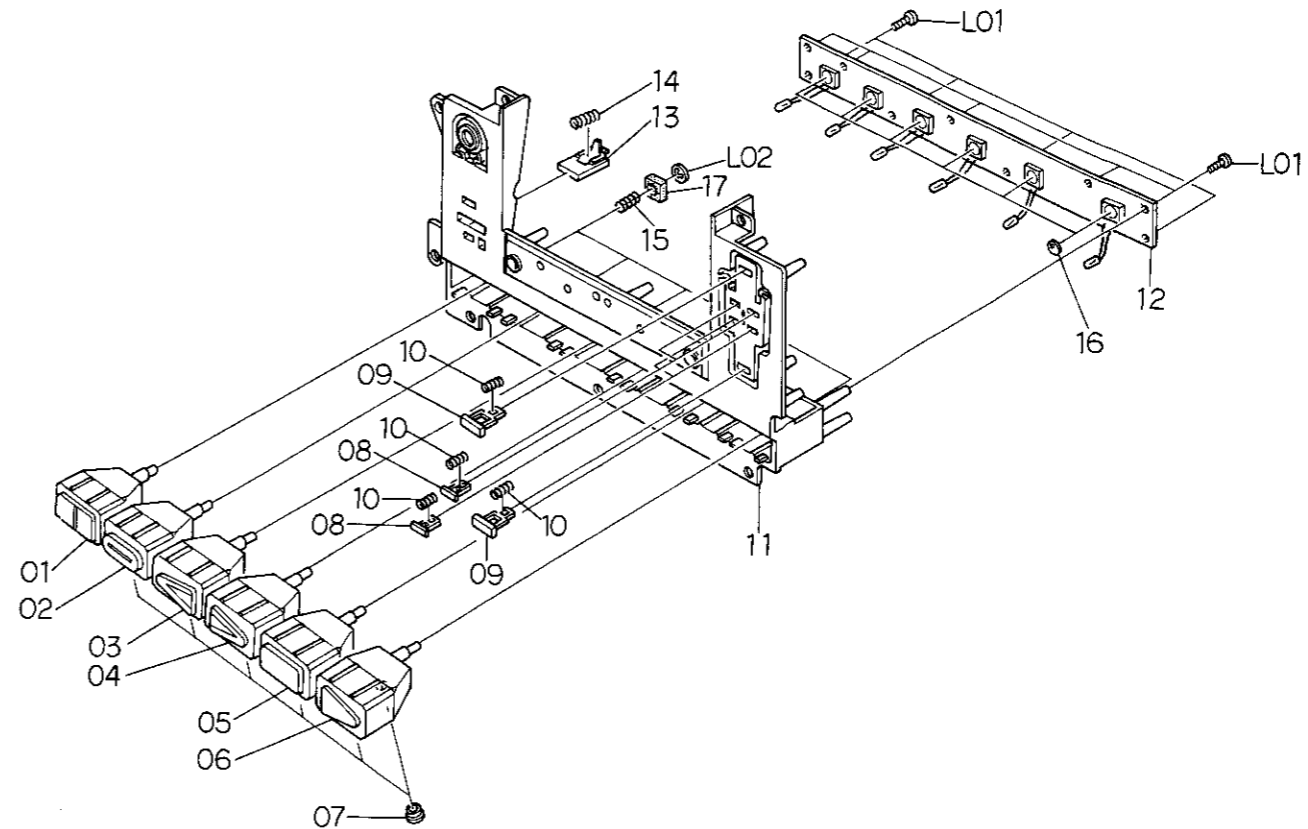

Fig. 2.11

Schematic Ref. No.	Part No.	Description	Q'ty
C04	HAL4015A	Front Escutcheon A Ass'y	1
01	HAL4002A	Pause Button Ass'y	1
02	HAL4003A	Record Button Ass'y	1
03	HAL4004A	Rewind Button Ass'y	1
04	HAL4005A	F.F. Button Ass'y	1
05	HAL4006A	Stop Button Ass'y	1
06	HAL4007A	Play Button Ass'y	1
07	OJ04109A	Lamp Holder	6
08	OHL3861A	Function Button A	4
09	OHL3862A	Function Button B	2
10	OJ04115B	Function Switch Spring	6
11	HA03998B	Front Escutcheon A Sub Ass'y	1
12	BAL4239A	Mechanism Control Switch P.C.B. Ass'y	1
13	OHL3865A	Eject Button	1
14	OJ04114A	Power Switch Spring	1
15	OJ04113B	Control Switch Spring	6
16	OJ04290B	Switch Cushion	6
17	OJ04296A	Button Cushion	6
L01	0E00857A	Screw M3x6 Philips Binding Head	9
L02	0E00926A	Stopper Ring CS 4mm	6

2.12. Mechanism Ass'y 1000ZXL LTD (D01)

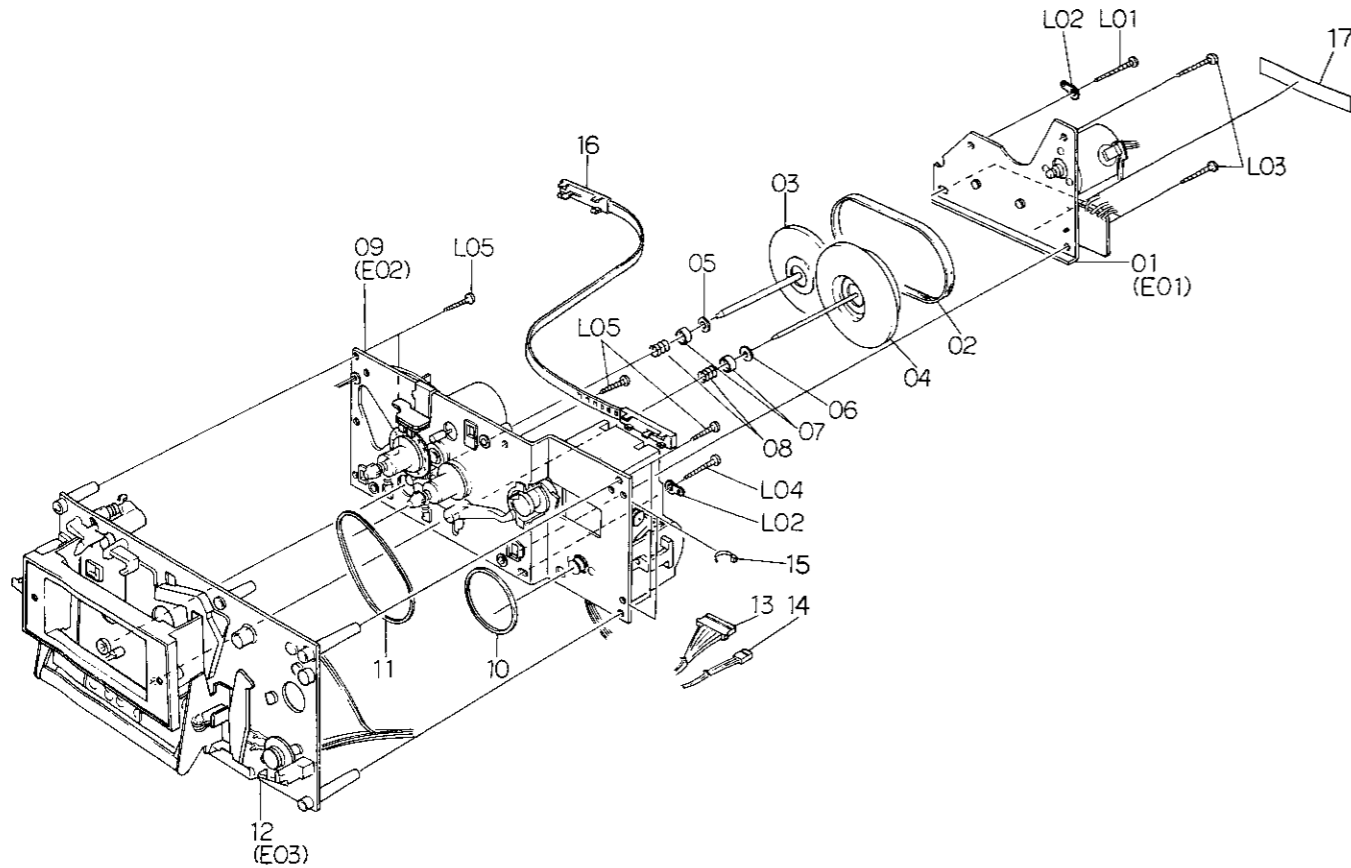

Fig. 2.12

2.13. Chassis Sub Ass'y (D02)

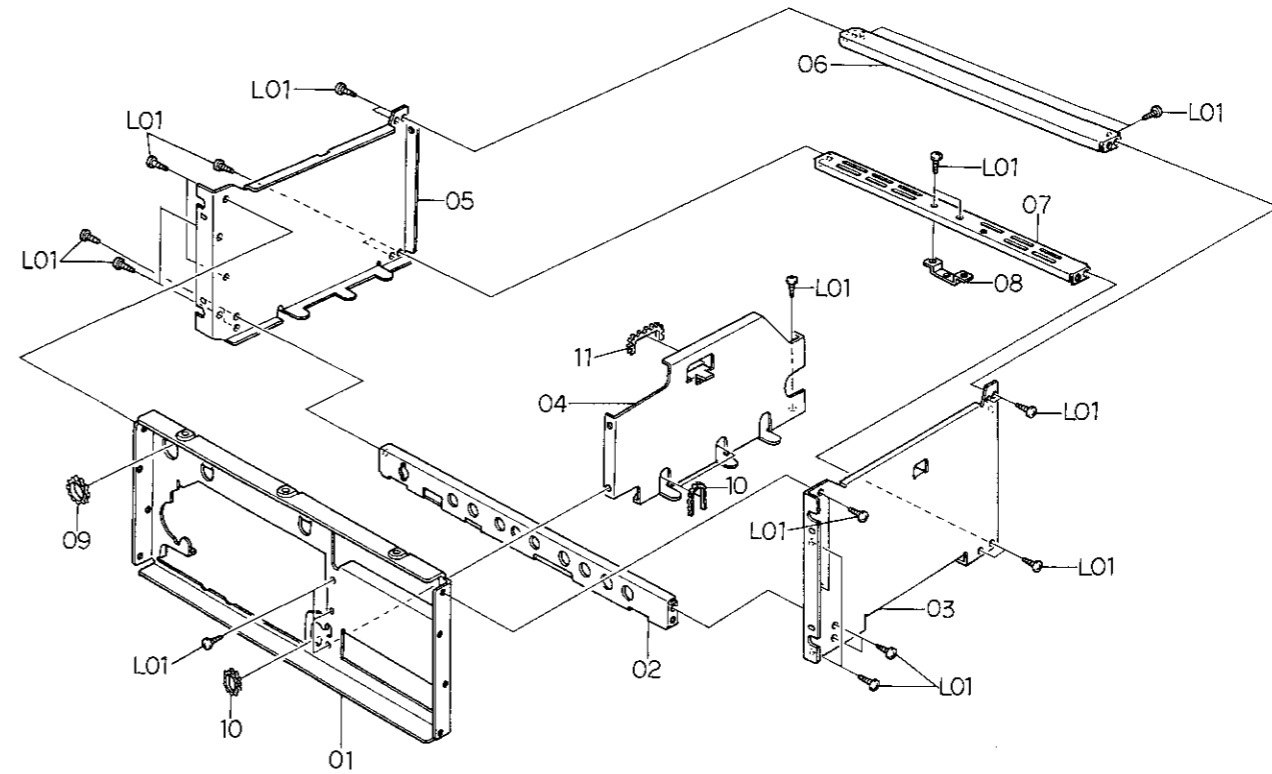

Fig. 2.13

Schematic Ref. No.	Part No.	Description	Q'ty	Schematic Ref. No.	Part No.	Description	Q'ty	Schematic Ref. No.	Part No.	Description	Q'ty				
D01	CA08368A	Mechanism Ass'y 1000ZXL LTD	1	L04	0E00835A	BT Screw M3x25 Philips Pan Head (Chromate)	1	E01	CAL8247A	Flywheel Holder Ass'y	1				
01	CAL8247A	Flywheel Holder Ass'y	1	L05	0E00883A	BT Screw M3x18 Philips Pan Head (Chromate)	5	01	0CL80131	Flywheel Holder	1				
02	0C08096C	Capstan Belt	1	D02	JAL3734A	Chassis Sub Ass'y	1	L01	CA08246A	Capstan Motor Ass'y	1				
03	CAL8173A	Supply Flywheel Ass'y	1					02	BA04238A	Speed Cal. P.C.B. Ass'y	1	L02	0E00226A	Screw M2.6x4 Philips Pan Head	3
04	CAL8015A	Take-up Flywheel Ass'y	1					03	0C08068C	Thrust Screw	2	L03	0C03857A	Lock Nut	2
05	0C08021B	Thrust Washer 3.1	1					04	0E00857A	BT Screw M3x6 Philips Binding Head	1	L04	0E00857A	BT Screw M3x6 Philips Binding Head	1
06	0C08020B	Thrust Washer 2.6	1					05	0E00037A	Earth Lug B-5	1	L05	0E00037A	Earth Lug B-5	1
07	0C08244A	Flange Thrust Cap	2					06	0E00233A	Washer 2.6mm Toothed Lock	3	L06	0E00233A	Washer 2.6mm Toothed Lock	3
08	0C08243A	Flange Thrust Spring	2					01	0JL4138B	Front Chassis	1				
09	CA08370A	Sub Mechanism Chassis Ass'y	1					02	0JL4143A	Switch Plate Holder	1				
10	0C08099B	Control Motor Belt	1					03	0JL4140D	Side Chassis R	1				
11	0C08098B	Counter Belt B	1					04	0JL4144C	Center Chassis	1				
12	CA08369A	Main Mechanism Chassis Ass'y	1					05	0JL4139D	Side Chassis L	1				
13	0BL8844A	10P-H Connector	1					06	0JL4142B	Top Plate	1				
14	0BL8652C	3P-H Connector	1					07	0JL4141A	Bottom Plate	1				
15	0B08515A	Insu-Lock	16					08	0JL4150A	Cabinet Holder	1				
16	0C08237A	Azimuth Alignment Wire	1					09	0B08774A	Free Bushing 74mm	1				
17	0M04309A	Check Seal	1					10	0B08775A	Free Bushing 67mm	3				
-	0M04169A	Mechanism Serial No. Seal	1					11	0B08773A	Free Bushing 91mm	1				
L01	0E00834A	BT Screw M3x30 Philips Pan Head	1	L01	0E00860A	BT Screw M3x6 Philips Binding Head (Black Chromate)	28								
L02	0E00037A	Earth Lug B-5	2												
L03	0E00833A	BT Screw M3x20 Philips Pan Head (Chromate)	3												

2.14. Flywheel Holder Ass'y (E01)

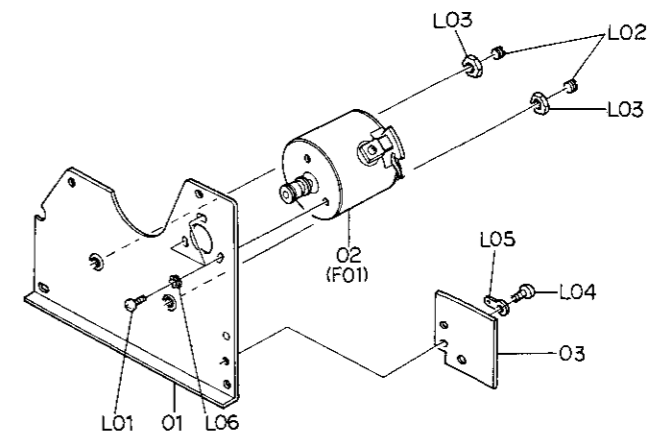

Fig. 2.14

2.15. Sub Mechanism Chassis Ass'y (E02)

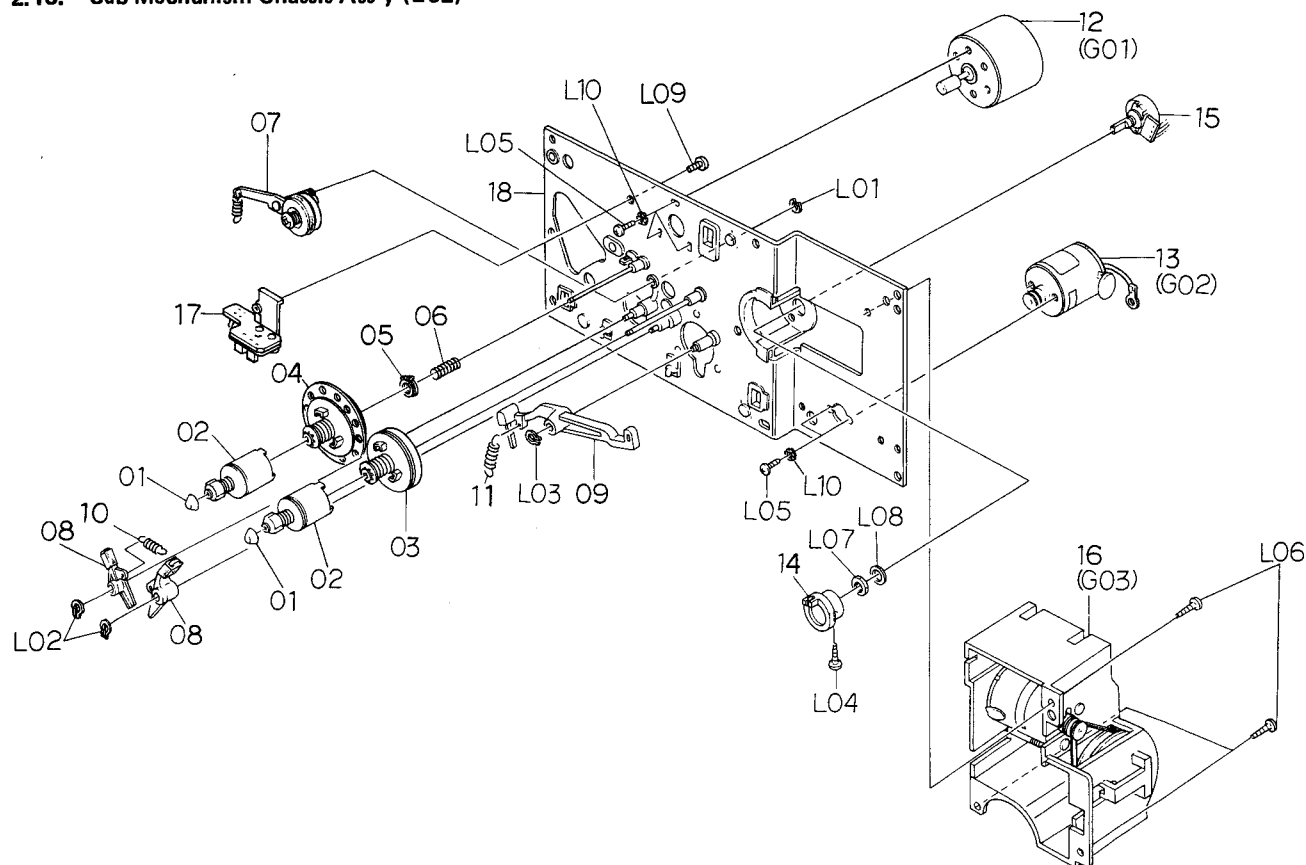

Fig. 2.15

Schematic Ref. No.	Part No.	Description	Q'ty	Schematic Ref. No.	Part No.	Description	Q'ty
E02	CA08370A	Sub Mechanism Chassis Ass'y	1	L04	0E00859A	BT Screw M2.6x6 Philips Binding Head (Chromate)	1
01	0C08039B	Reel Hub Head	2	L05	0E00226A	Screw M2.6x4 Philips Pan Head (Bronze)	5
02	CA08371A	Reel Hub B Ass'y	2	L06	0E00846A	BT Screw M3x8 Philips Pan Head (Chromate)	3
03	CA08037A	Reel Hub Take-up Ass'y	1	L07	—	Volume Nut	(1)
04	CA08236A	Reel Hub Supply Ass'y	1	L08	—	Volume Washer	(1)
05	CA08039A	Back Tension Ass'y	1	L09	0E00792A	BT Screw M2.6x6 Philips Pan Head (Chromate)	1
06	0C08269A	Back Tension Spring	1	L10	0E00233A	Washer 2.6mm Toothed Lock	5
07	CAL8193A	Idler Ass'y	1				
08	CAL8042A	Brake Ass'y	2				
09	0CL8030C	Brake Drive Arm	1				
10	0C08129A	Brake Arm Spring	1				
11	0C08128A	Brake Drive Arm Spring	1				
12	CA08242A	Reel Motor Ass'y	1				
13	CAL8034A	Control Motor Ass'y	1				
14	0CL8053B	Volume Coupler	1				
15	0B07240A	Volume Control 10kΩ (B)	1				
16	CAL8148A	Azimuth Alignment Motor Ass'y	1				
17	BAL4237B	Counter Pulse Generator P.C.B. Ass'y	1				
18	CAL8194A	Sub Chassis Ass'y	1				
L01	0E00698A	E-Ring 2.5mm	1				
L02	0E00837A	Stopper Ring 3mm	2				
L03	0E00838A	Stopper Ring 4mm	1				

Schematic Ref. No.	Part No.	Description	Q'ty
E03	CA08369A	Main Mechanism Chassis Ass'y	1
01	CAL8239A	Cassette Case Holder L Ass'y	1
02	0C08151A	Lid Arm Spring Tube	1
03	CAL8022A	Cassette Case Holder R Ass'y	1
04	CAL8240A	Cassette Case Ass'y	1
05	CA08373A	Head Mount Base Ass'y	1
06	0C08121A	Supply Pressure Roller Spring	1
07	0C08250A	Supply Pressure Roller Spring B	1
08	CAL8053B	Supply Pressure Roller Ass'y	1
09	0C08122B	Supply Pressure Roller Thrust Spring	1
10	CAL8079B	Take-up Pressure Roller Ass'y	1
11	0C08183B	Take-up Pressure Roller Thrust Spring	1
12	CA08372A	Head Base Ass'y E	1
13	0CL8182A	Pressure Roller Drive Bar B	1
14	0CL8086B	Head Base Roller	3
15	0CL8050B	Record Sensor	1
16	0CL8051E	Cassette Hold Arm	1
17	0C08120A	Cassette Hold Spring	1
18	CAL8196A	Back Tension Arm Ass'y	1
19	0C08254A	Tension Arm Collar	1
20	CAL8027A	Head Base Drive Arm Ass'y	1
21	0C08143C	Head Base Drive Arm Spring	1
22	CAL8026A	Pressure Roller Drive Arm Ass'y	1
23	CAL8237A	Auto Shut-off Ass'y	1
24	0C08119A	Record Protector	1
25	0CL8194C	Damper Lock Arm	1
26	0C08153A	Damper Lock Arm Spring Tube	1
27	0C08116A	Record Arm Spring	2
28	CAL8030A	Pneumatic Damper Ass'y	1
29	CA08291A	Supply Capstan Flange Ass'y	1
30	CA08292A	Take-up Capstan Flange Ass'y	1
31	0CL8186A	Cam Drive Gear	1
32	0CL8029H	Control Cam	1
33	0C08117A	Counter-Load Arm Spring	1
34	0C08152A	Counter-Load Arm Spring Tube	1
35	CAL8028A	Counter-Load Arm Ass'y	1
36	CAL8183A	Main Chassis Ass'y	1
L01	0E00837A	Stopper Ring 3mm	9
L02	0E00172A	Washer 3mm Toothed Lock	3
L03	0E00834A	BT Screw M3x30 Philips Pan Head (Chromate)	2
L04	0E00831A	BT Screw M3x10 Philips Pan Head (Chromate)	3
L05	0E00254A	Washer 3.1mm (Plastics)	2
L06	0E00222A	E-Ring 2mm	2
L07	0E00876A	BT Screw M2.6x8 Philips Pan Head (Chromate)	8
L08	0CL8060B	Height Adjustment Nut	2
L09	0E00142A	Washer 2.6mm	2
L10	0E00879A	BT Screw M2x15 Philips Pan Head (Chromate)	1
L11	0E00838A	Stopper Ring 4mm	3
L12	0E00846A	BT Screw M3x8 Philips Pan Head (Chromate)	3
L13	0E00895A	Earth Lug 3mm	2
L14	0E00859A	BT Screw M2.6x6 Philips Binding Head (Chromate)	1
L15	0E00255A	Washer 2.6mm	1

2.16. Main Mechanism Chassis Ass'y (E03)

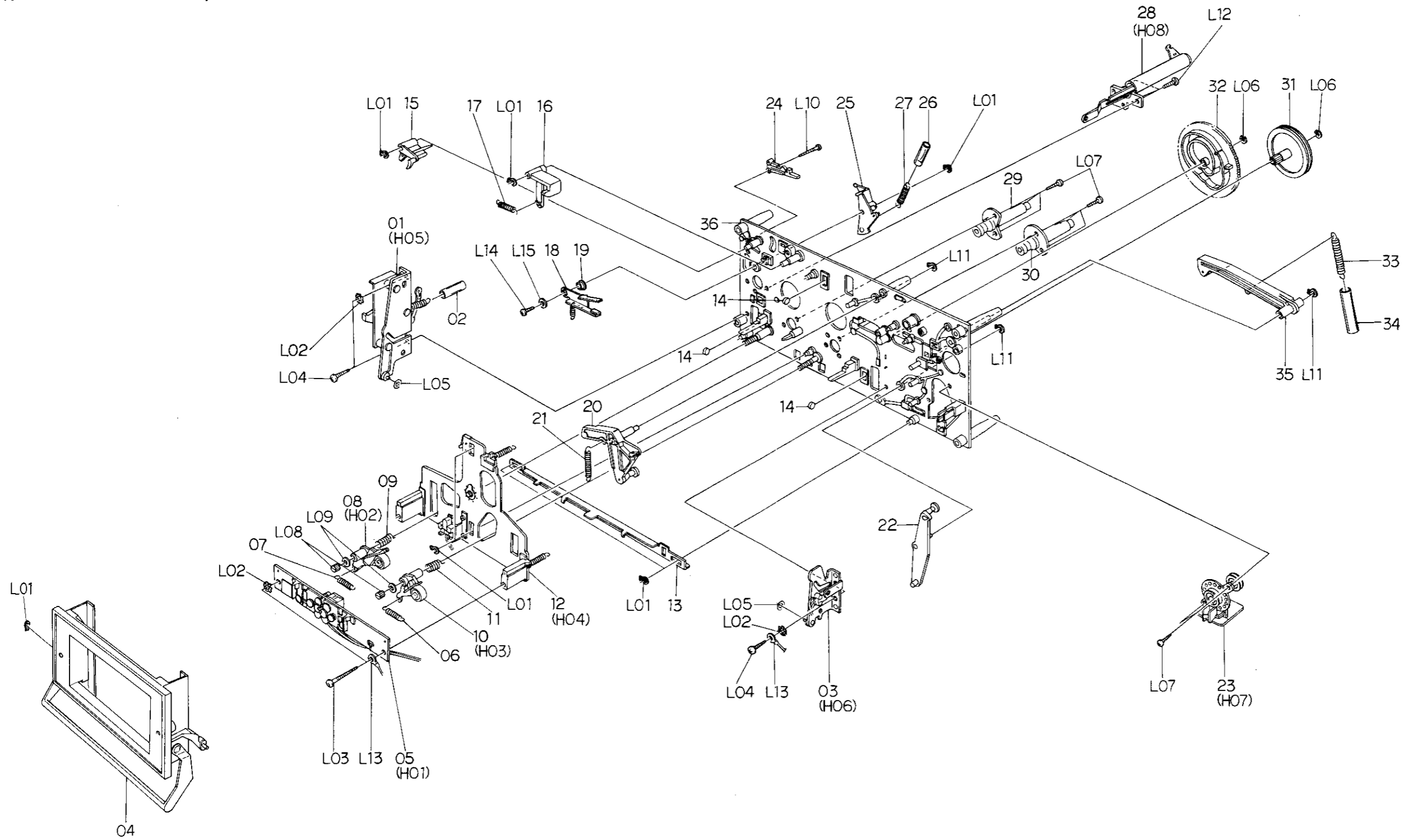

Fig. 2.16

2.17. Capstan Motor Ass'y (F01)

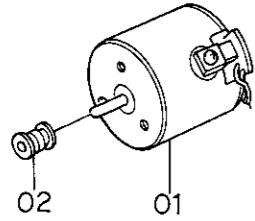

Fig. 2.17

2.18. Reel Motor Ass'y (G01)

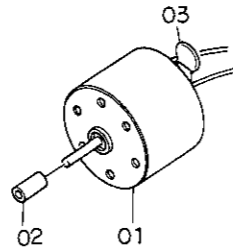

Fig. 2.18

2.19. Control Motor Ass'y (G02)

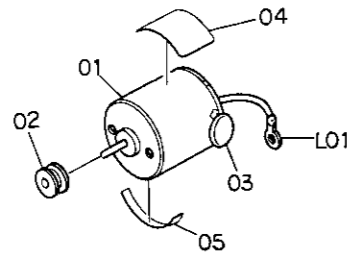

Fig. 2.19

2.20. Azimuth Alignment Motor Ass'y (G03)

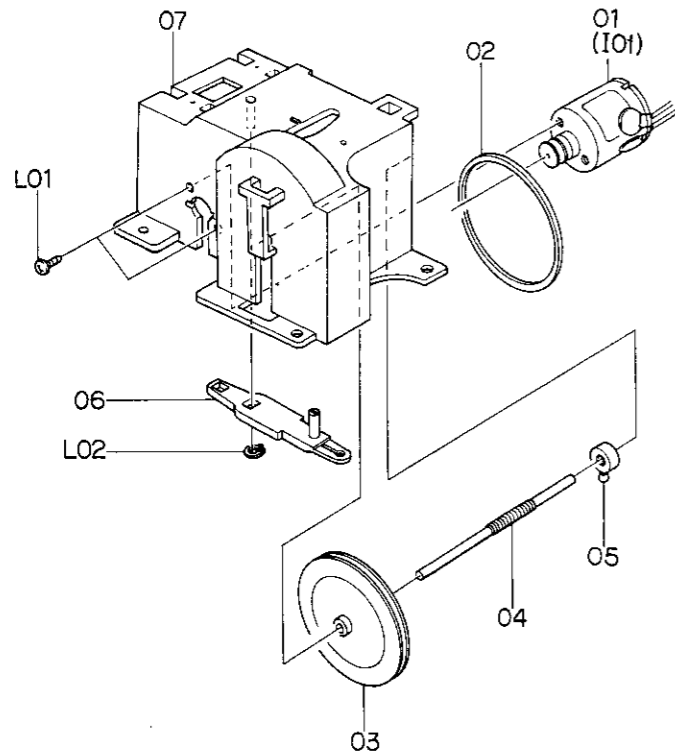

Fig. 2.20

2.21. Head Mount Base Ass'y (H01)

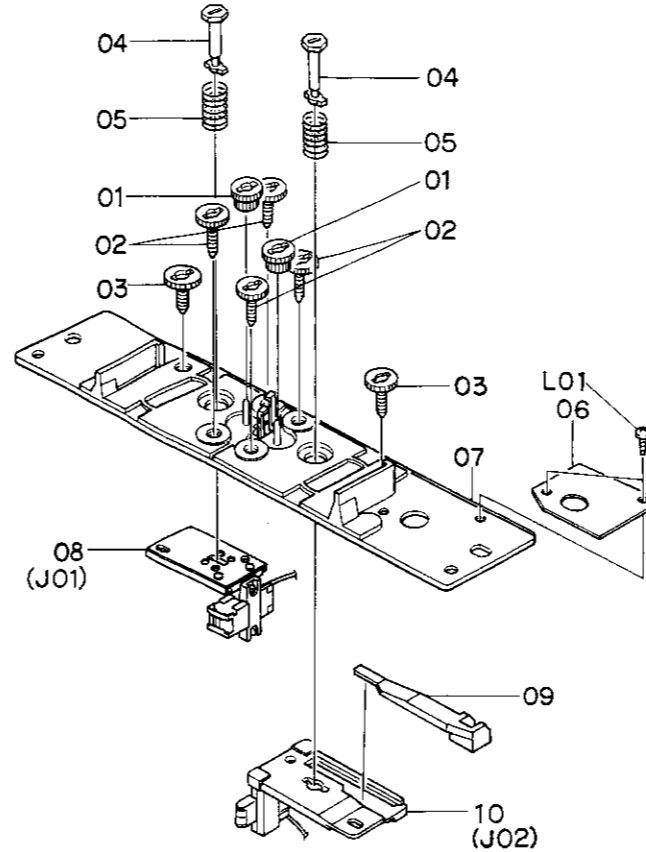

Fig. 2.21

2.22. Supply Pressure Roller Ass'y (H02)

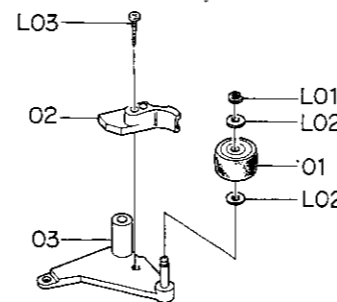

Fig. 2.22

2.23. Take-up Pressure Roller Ass'y (H03)

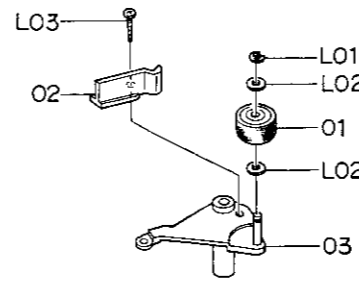

Fig. 2.23

Schematic Ref. No.	Part No.	Description	Q'ty
F01	CA08246A	Capstan Motor Ass'y	1
01	0C08271A	Capstan Motor	1
02	0C08079G	Capstan Motor Pulley	1
G01	CA08242A	Reel Motor Ass'y	1
01	0C08272A	Reel Motor	1
02	0C08063F	Reel Motor Pulley	1
03	0B09290A	Ceramic Capacitor 0.01μ 50V Z	1
G02	CAL8034A	Control Motor Ass'y	1
01	0C08137A	Control Motor	1
02	0CL8064A	Control Motor Pulley	1
03	0B09292A	Ceramic Capacitor 0.1μ 50V Z	1
04	0M03985A	Motor Label 730	1
05	0M03988A	Motor Seal B	1
L01	0E00037A	Earth Lug B-5	1
G03	CAL8148A	Azimuth Alignment Motor Ass'y	1
01	CAL8149A	Azimuth Motor Ass'y	1
02	0C08099B	Control Motor Belt	1
03	0C08229B	Drive Pulley	1
04	0C08230B	Drive Pulley Shaft	1
05	0C08231C	Drive Nut	1
06	0C08232C	Drive Bar	1
07	0C08233G	Drive Unit Base	1
L01	0E00226A	Screw M2.6x4 Philips Pan Head	2
L02	0E00837A	Stopper Ring 3mm	1
H01	CA08373A	Head Mount Base Ass'y	1
01	0CL8028C	Head Height Adjustment Gear	2
02	0CL8027F	Head Height Adjustment Screw	4
03	0CL8026D	Azimuth Alignment Screw	2
04	0CL8161B	Spring Stopper	2
05	0C08187B	Head Plate Spring	2
06	0CL8236A	Azimuth Alignment Wire Hold Plate	1
07	CAL8083C	Head Mount Base Sub Ass'y	1
08	CAL8244A	P-8L Playback Head Ass'y	1
09	0CL8235A	Azimuth Alignment Plate	1
10	CAL8238A	R-8L Record Head Ass'y	1
L01	0E00824A	BT Screw M2.6x6 Philips Pan Head (Black Chromate)	2
H02	CAL8053B	Supply Pressure Roller Ass'y	1
01	0C08164G	Pressure Roller	1
02	0C08189B	Supply Tape Guide	1
03	CAL8061A	Supply Pressure Roller Arm Ass'y	1
L01	0E00042A	E-Ring 1.5mm	1
L02	0C08024A	Washer 2mm	2
L03	0E00788A	BT Screw M2x8 Philips Pan Head	1

Schematic Ref. No.	Part No.	Description	Q'ty	Schematic Ref. No.	Part No.	Description	Q'ty
H03	CAL8079B	Take-up Pressure Roller Ass'y	1	H08	CAL8030A	Pneumatic Damper Ass'y	1
01	0C08164G	Pressure Roller	1	01	0CL8058C	Damper Piston	1
02	0C08181C	Take-up Tape Guide	1	02	0C08102C	Damper Ring	1
03	CAL8073B	Take-up Pressure Roller Arm Ass'y	1	03	0C08010C	Damper Plate	1
L01	0E00042A	E-Ring 1.5mm	1	04	0CL8059D	Sylinder	1
L02	0C08024A	Washer 2mm	2	L01	0E00874A	Stopper Ring CS 2mm	1
L03	0E00788A	BT Screw M2x8 Philips Pan Head	1	I01	CAL8149A	Azimuth Motor Ass'y	1
H04	CA08372A	Head Base Ass'y E	1	01	0C08137A	Control Motor	1
01	GAL2083A	E-8LH Erase Head	1	02	0CL8064A	Control Motor Pulley	1
02	0C08158D	EH Hold Plate	1	03	0B09292A	Ceramic Capacitor 0.1μ 50V Z	2
03	0C08166A	EH Hold Plate Spring	1	04	0M03985A	Motor Label 730	1
04	0CL8174D	Cassette Hold Spring	1	05	0M03988A	Motor Seal B	1
05	CAL8003Q	Head Base Ass'y	1	06	0BL8708A	2P Connector	1
06	0C08175A	Head Base L Spring	3				
07	0BL8764A	2P-H Connector	1				
L01	0E00889A	Screw M1.7x8 Philips Pan Head	2				
L02	0E00909A	Screw M2x6 Philips Pan Head	3				
L03	0E00117A	Washer 2mm	3				
L04	0E00853A	BT Screw M2x3 Philips Pan Head	1				
L05	0E00952A	Washer 1.7mm	2				
H05	CAL8239A	Cassette Case Holder L Ass'y	1				
01	CAL8090F	Cassette Case L Sub Ass'y	1				
02	0CL8073C	Lid Arm A	1				
03	0CL8195G	Arm Holder	1				
04	0CL8245A	Eject Arm A	1				
05	0CL8197C	Eject Arm B	1				
06	0CL8199B	Eject Arm Joint	1				
07	0C08114A	Lid Arm Spring	1				
08	0C08211C	Eject Arm Spring	1				
09	0CL8248B	Pitch Control Volume Holder	1				
10	0B07282A	Volume Control 20kΩ (B)	1				
L01	0E00837A	Stopper Ring 3mm	1				
L02	0E00838A	Stopper Ring 4mm	1				
L03	0E00865A	BT Screw M3x10 Philips Binding Head	2				
L04	-	Volume Nut	(1)				
L05	-	Volume Washer	(1)				
H06	CAL8022A	Cassette Case Holder R Ass'y	1				
01	0C08133A	Eject Sensor	1				
02	CAL8044A	Cassette Case Holder R Sub Ass'y	1				
L01	0E00840A	BT Screw M2x8 Philips Pan Head	2				
H07	CAL8237A	Auto Shut-off Ass'y	1				
01	0CL8047A	Shut-off Pulley A	1				
02	0C08206B	Shut-off Pulley B	1				
03	0C08088B	Shut-off Pulley Shaft	1				
04	0C08207B	Shut-off Pulley Holder	1				
05	BAL4070A	Shut-off P.C.B. Ass'y	1				

2.24. Head Base Ass'y E (H04)

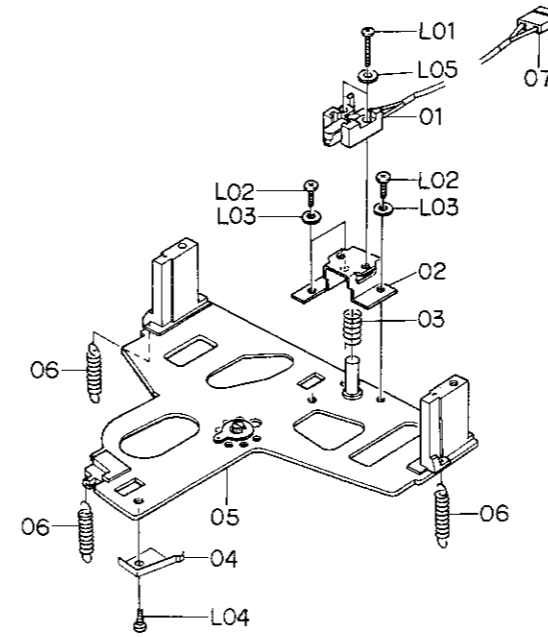

Fig. 2.24

2.25. Cassette Case Holder L Ass'y (H05)

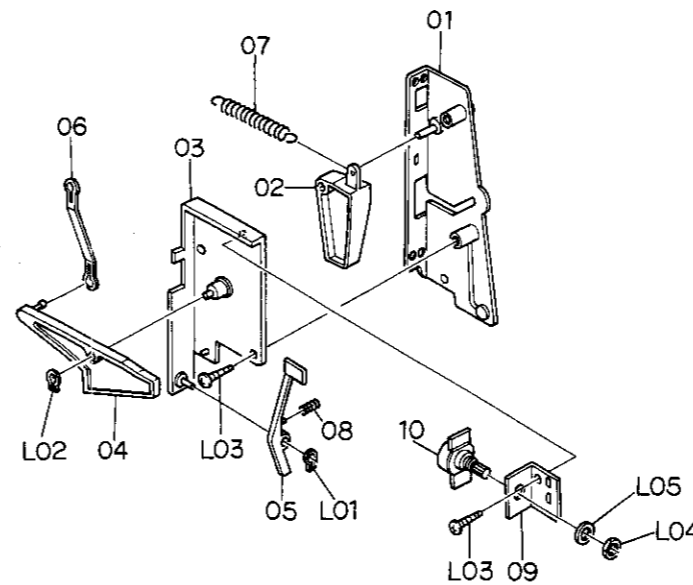

Fig. 2.25

2.26. Cassette Case Holder R Ass'y (H06)

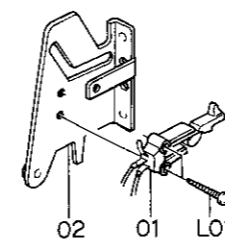

Fig. 2.26

2.27. Auto Shut-off Ass'y (H07)

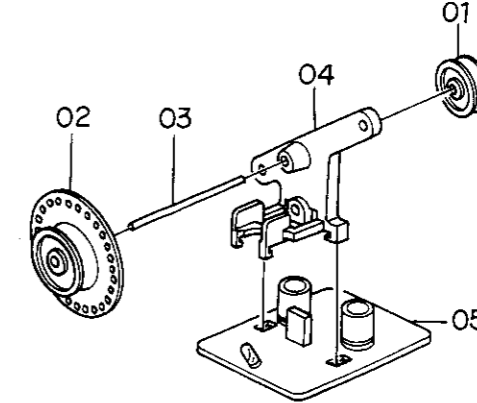

Fig. 2.27

2.28. Pneumatic Damper Ass'y (H08)

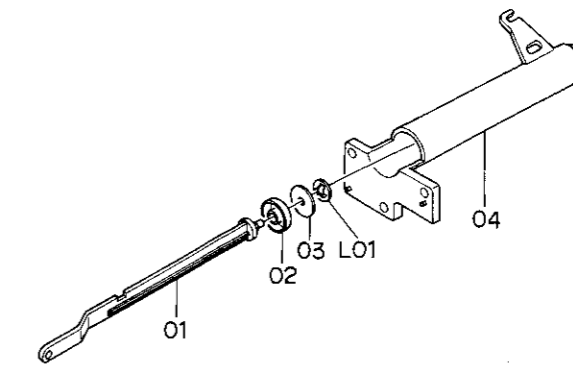

Fig. 2.28

2.29. Azimuth Motor Ass'y (I01)

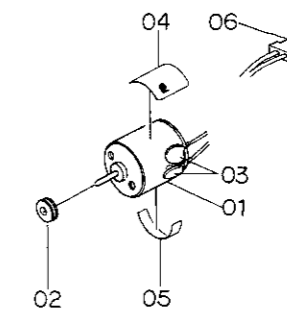

Fig. 2.29

3. WIRING DIAGRAM

2.30. P-8L Playback Head Ass'y (J01)

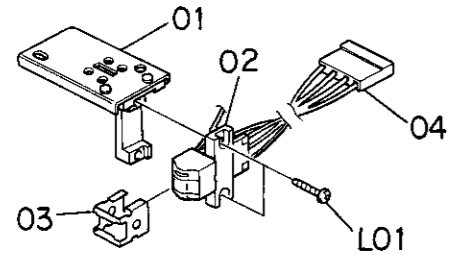

Fig. 2.30

2.31. R-8L Record Head Ass'y (J02)

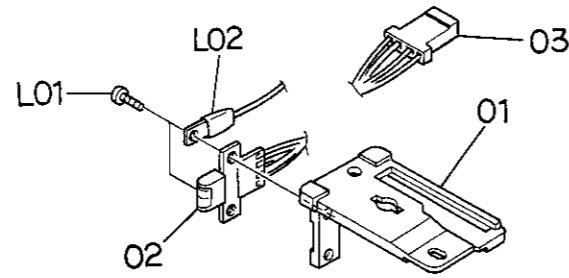

Fig. 2.31

Schematic Ref. No.	Part No.	Description	Q'ty
J01	CAL8244A	P-8L Playback Head Ass'y	1
01	CAL8307A	Head Plate Ass'y	1
02	GAL2101A	P-8LZ Playback Head	1
03	OCL8169D	Pad Lifter 54	1
04	OBL8767A	4P-H Connector	1
L01	0E00886A	Screw M1.7x6 Philips Pan Head	2
J02	CAL8238A	R-8L Record Head Ass'y	1
01	OCT8234B	Head Plate	1
02	GAL2102A	R-8LZ Record Head	1
03	OBL8768A	4P-H Connector	1
L01	0E00887A	Screw M1.7x4 Philips Pan Head	2
L02	0C08304A	RH Grounding Terminal	1

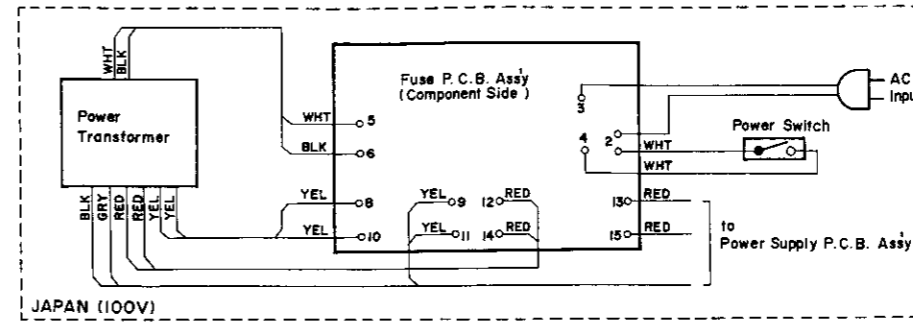
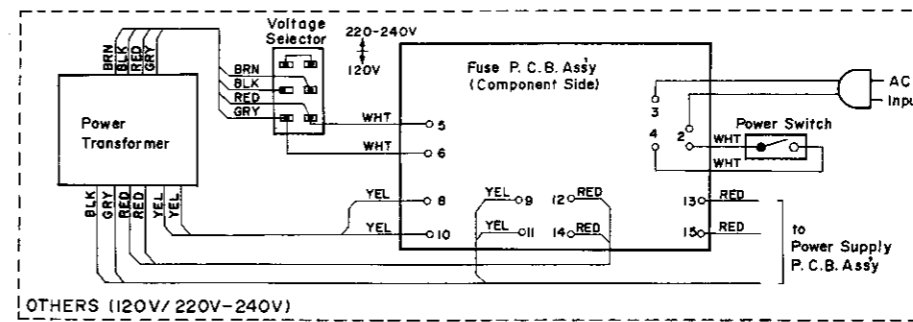
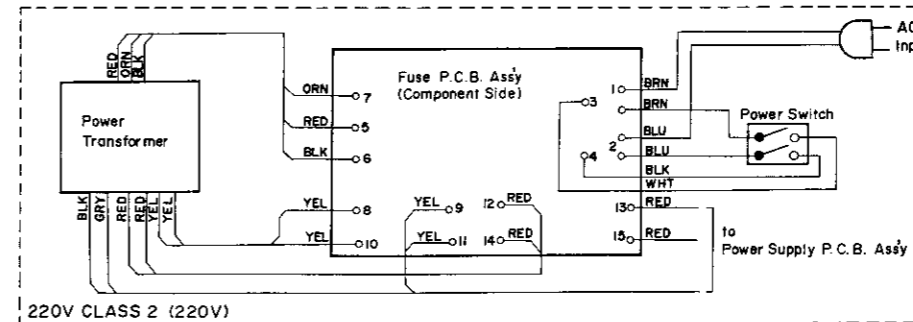
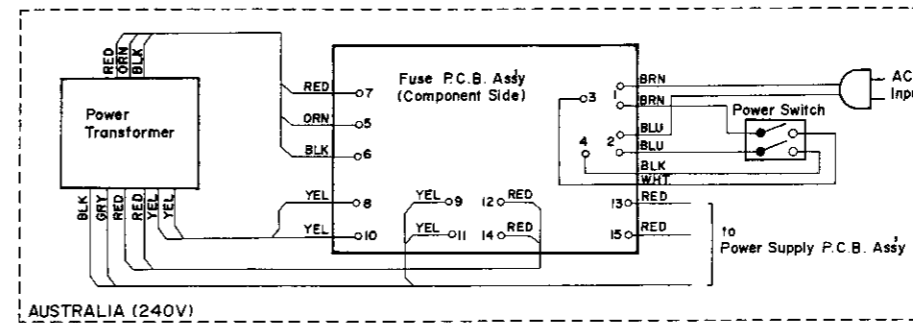
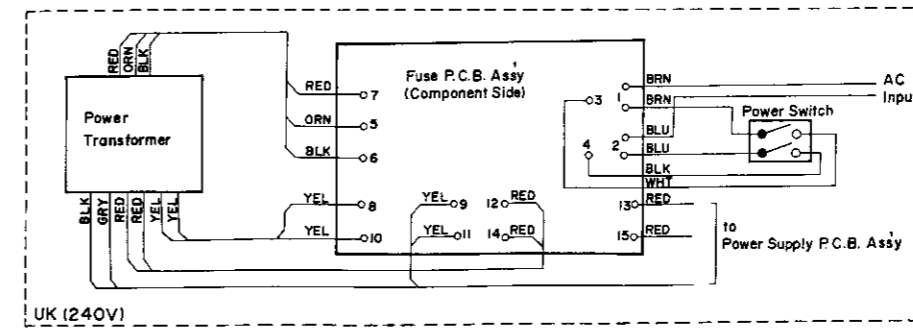

Fig. 3.1

Note: Table of wire colors:

- BLK - Black
- BLU - Blue
- GRN - Green
- RED - Red
- WHT - White
- ORN - Orange
- GRY - Gray
- BRN - Brown
- YEL - Yellow
- VIO - Violet

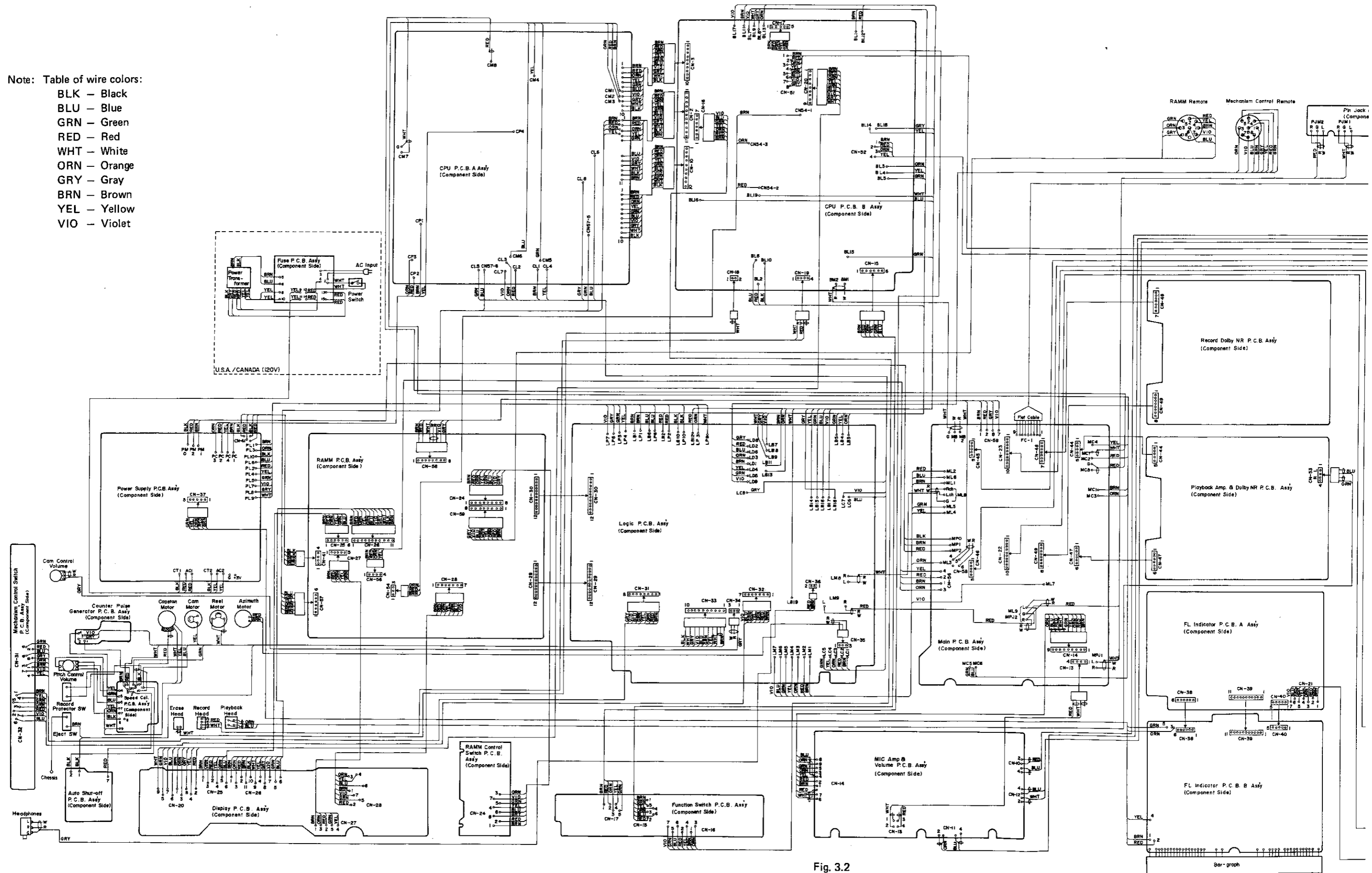

Fig. 3.2

4. SCHEMATIC DIAGRAMS

4.1. Attention to Servicemen

(1) Parts Replacement

Following parts shall be replaced with the specified ones. Refer to the parts list.

- (a) Power Circuit
 - Power Cord
 - Power Transformer T1
 - Power Switch SW1

- (b) Fuse P.C.B. Ass'y
 - Spark Killer
 - F401-405

- (c) Power Supply P.C.B. Ass'y
 - Q403, 404, 405, 409, 410, 419
 - D401

- (d) Function Switch P.C.B. Ass'y
 - PL701-708

- (e) Mechanism Control Switch P.C.B. Ass'y
 - PL601-606

- (f) Counter Pulse Generator P.C.B. Ass'y
 - PL601
 - R601

- (g) Shut-off P.C.B. Ass'y
 - R605
 - PL407

- (h) Detector P.C.B. Ass'y
 - R946, 947

- (i) Record Dolby NR P.C.B. Ass'y
 - RL301

- (j) Record Eq. Amp. P.C.B. Ass'y
 - R301, 302

- (k) MIC Amp. and Volume P.C.B. Ass'y
 - R315, 316

- (l) Playback Amp. and Dolby NR P.C.B. Ass'y
 - R303, 304

- (m) Main P.C.B. Ass'y
 - RL301, 302

- (n) Logic P.C.B. Ass'y
 - Q101, 102, 201, 202, 504, 505, 506, 507, 538, 539
 - R104, 204, 540, 571, 572, 573, 606, 619, 626, 635

- (o) CPU P.C.B. B Ass'y
 - Q102, 103, 202, 203, 819, 820, 822, 823
 - R828, 834, 835, 836, 837, 872, 873, 874, 875, 876, 877, 889, 890

- (p) RAMM P.C.B. Ass'y
 - R901, 902, 904, 905, 001-017

- (q) Display P.C.B. Ass'y
 - PL001-028

(2) Insulation Check

Before returning the repaired N-1000ZXL Limited Version to a customer, check to insure that the exposed part is accurately insulated from the AC line by measuring the leakage current or the insulation resistance between them.

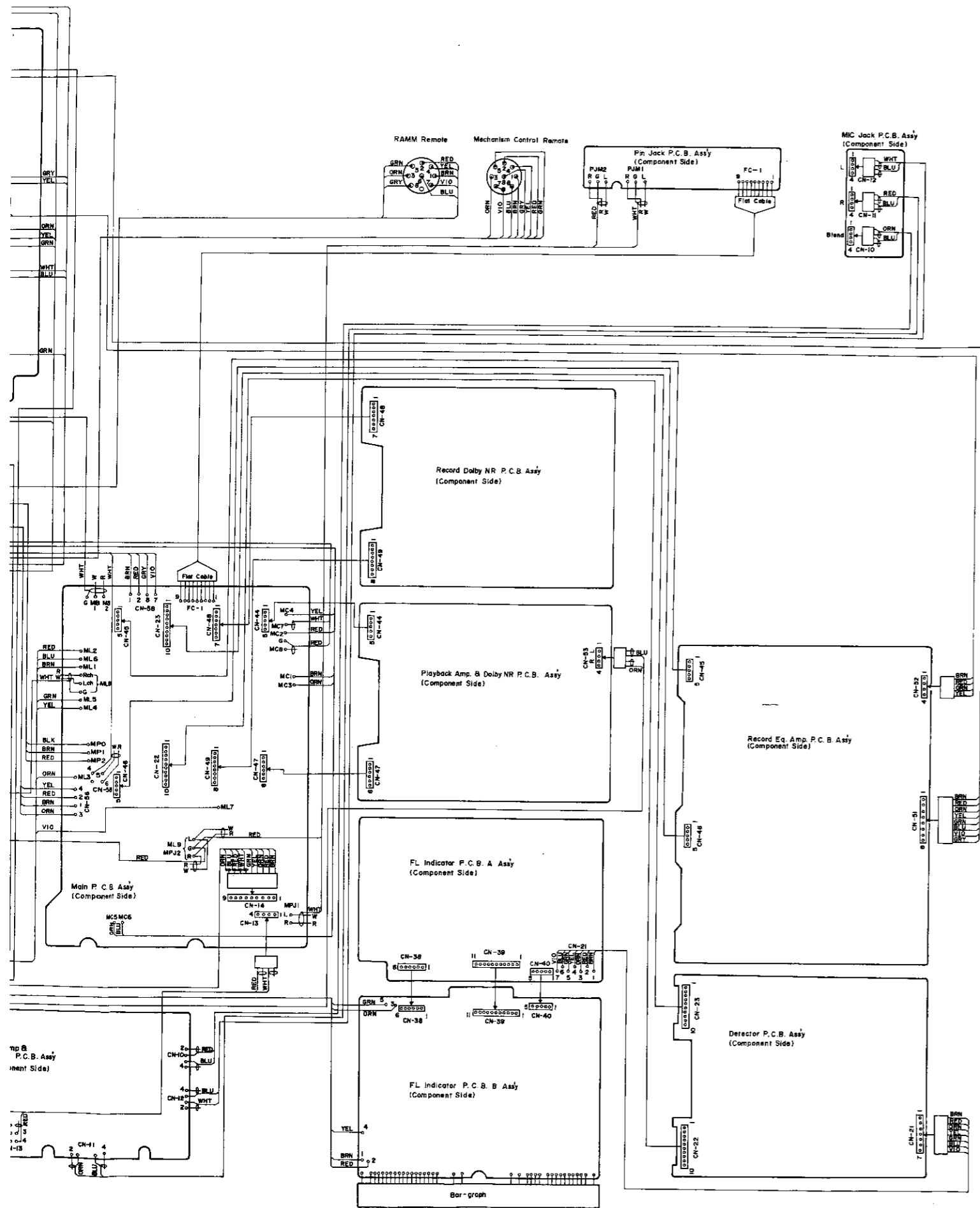

4.2. Amplifier Section

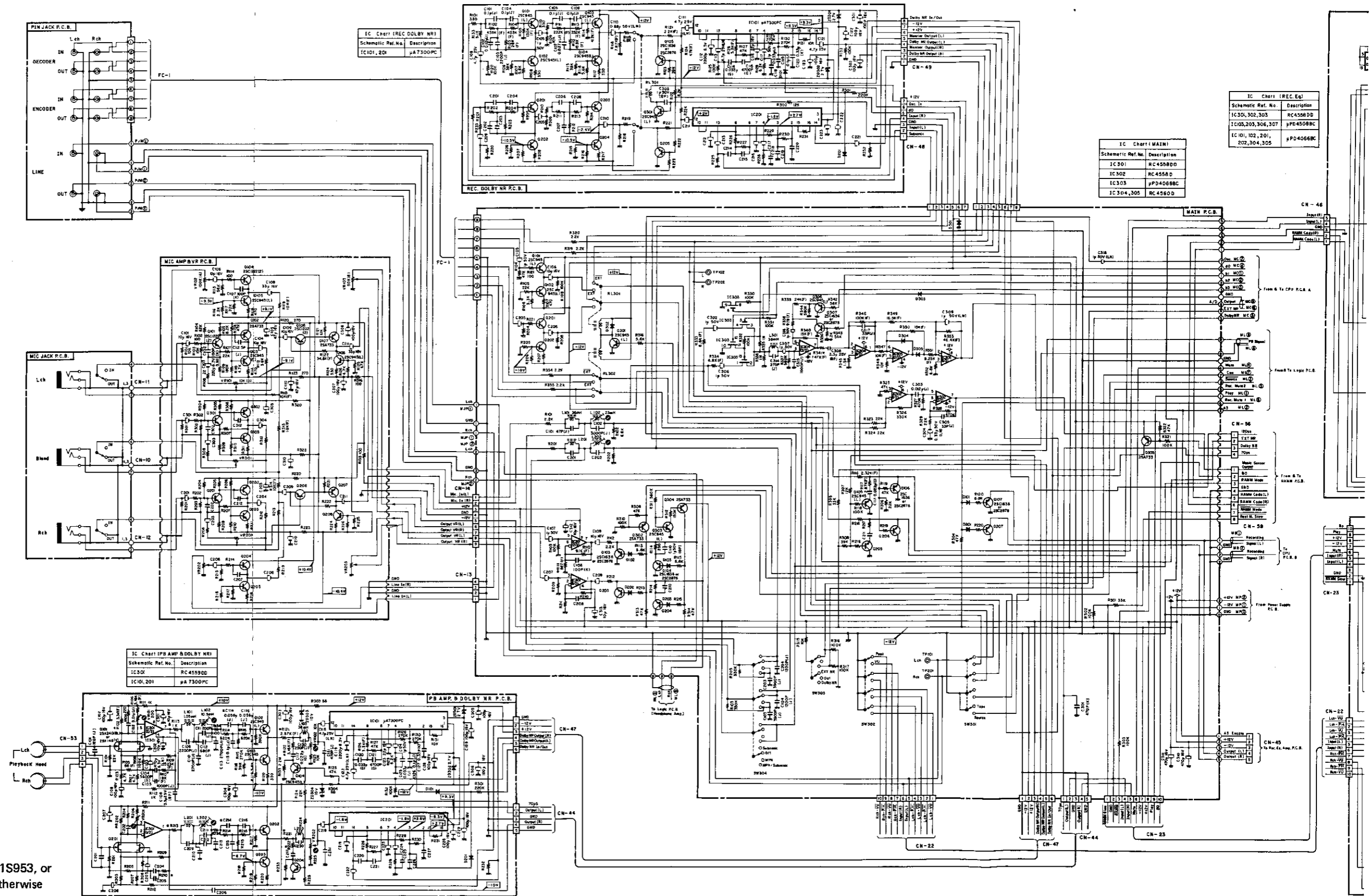

- Notes: 1. Diode is 1S553, 1S953, or 1S1555 unless otherwise specified.
2. Resistor and capacitor marked with * show typical value.

Fig. 4.1

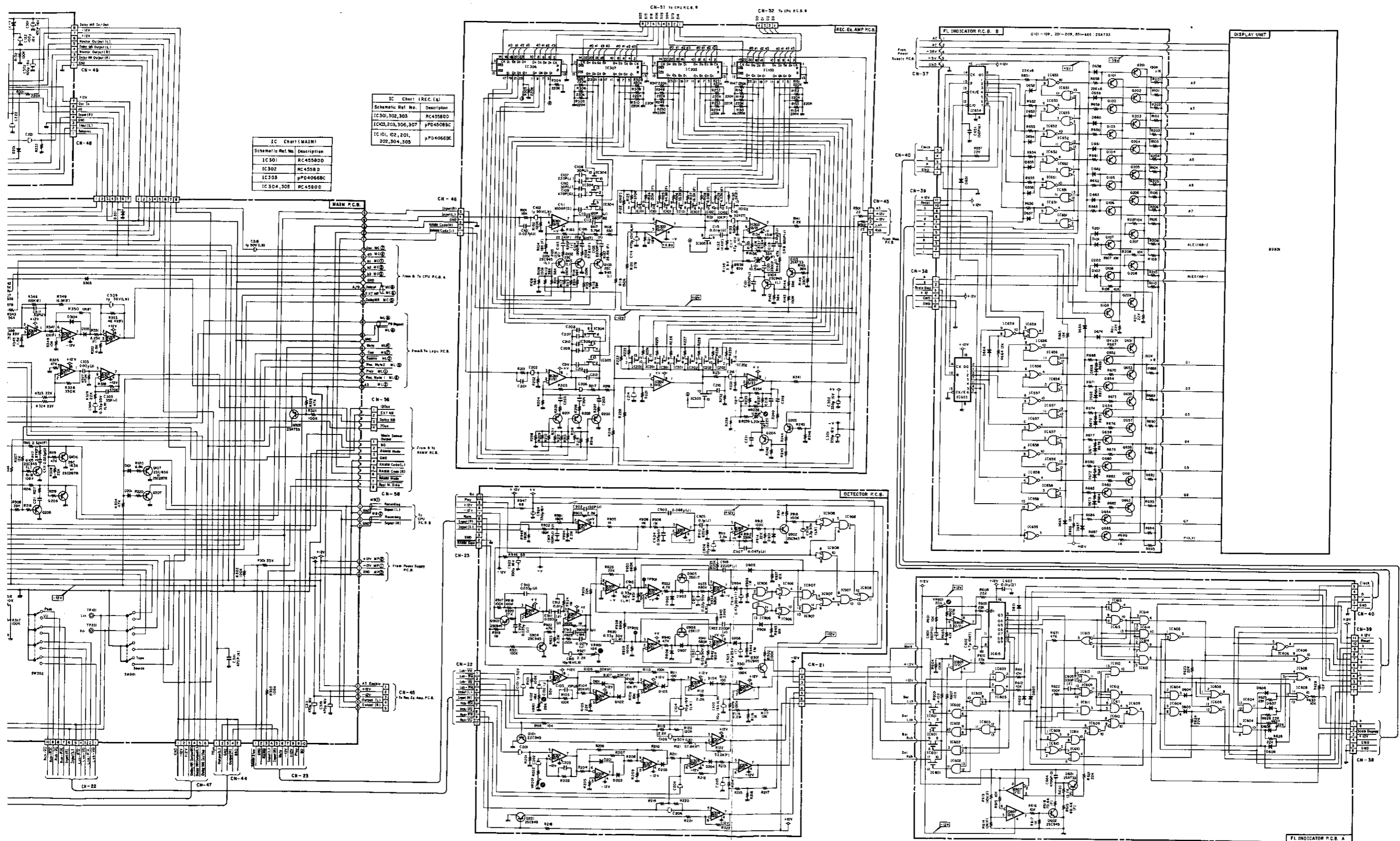

IC Chart (MAIN)

Schematic Ref. No.	Description
IC 301	RC4558DD
IC 302	RC4558D
IC 303	μPD4066BC
IC 304, 305	RC4580D

IC Chart (REC. Ex.)

Schematic Ref. No.	Description
IC 301, 302, 303	RC4558DD
IC 303, 304, 305, 307	μPD4066BC
IC 401, 402, 201, 202, 304, 305	μPD4066BC

IC Chart (FL INDICATOR A, B, DETECTOR)

Schematic Ref. No.	Description	Schematic Ref. No.	Description	Schematic Ref. No.	Description	Schematic Ref. No.	Description
IC 301, 304, 305	RC4558D	IC 603, 613	μPD4011BC	IC 607	RC4560D	IC 901, 902, 903, 904	RC4558D
IC 302, 303, 305	μPD4066BC	IC 605	IC608	IC 608	μPD4023BC	IC 905	IC 654, 655
IC 601	μPD4066BC	IC 606, 610, 651-653	μPD4011BC	IC 609	μPD4071BC	IC 906, 907, 908	μPD4011BC
IC 602, 604, 611	μPD4066BC	IC 656, 657, 658, 659	μPD4011BC	IC 612, 614	μPD4075BC	IC 615	μPD4040BC

4.3. CPU Section

IC Chart (CPU A Section)	
Schematic Ref. No.	Description
IC701	μ P0546C13
IC702	μ P0401LC
IC703	μ P04508BC
IC704, 705	μ P04516BC
IC706, 707, 708, 709	μ P04081BC
IC711	μ P04071BC
IC712	μ P04001BC
IC713, 304	RC4850D
IC301	RC4850C
IC302	RC4850D
IC303	μ P04011BC

IC Chart (CPU B Section)	
Schematic Ref. No.	Description
IC801, 801, 802	μ P04508BC
IC803, 808	μ P04011BC
IC804	μ P04001BC
IC805	RC4850D
IC806	μ P04040BC
IC807	μ P04069BC
IC808	μ P04081BC
IC809	TC4814BP
IC801	TC4814BP
IC801	TC4856C

IC Chart (DISPLAY Section)	
Schematic Ref. No.	Description
IC001	MSM5512
IC002	TS5022BP
IC003	MS4016P

IC Chart (RAMM Section)	
Schematic Ref. No.	Description
IC901	μ P0546C14
IC902, 903	μ P04508BC
IC904, 905, 913	TC4013BP
IC906, 907, 908, 909	μ P04081BC
IC910, 916, 918	RC4556D
IC911	RC4510BP
IC912	TC4810BP
IC914	μ P04071BC
IC915	TC4023BP
IC917	μ P04069C

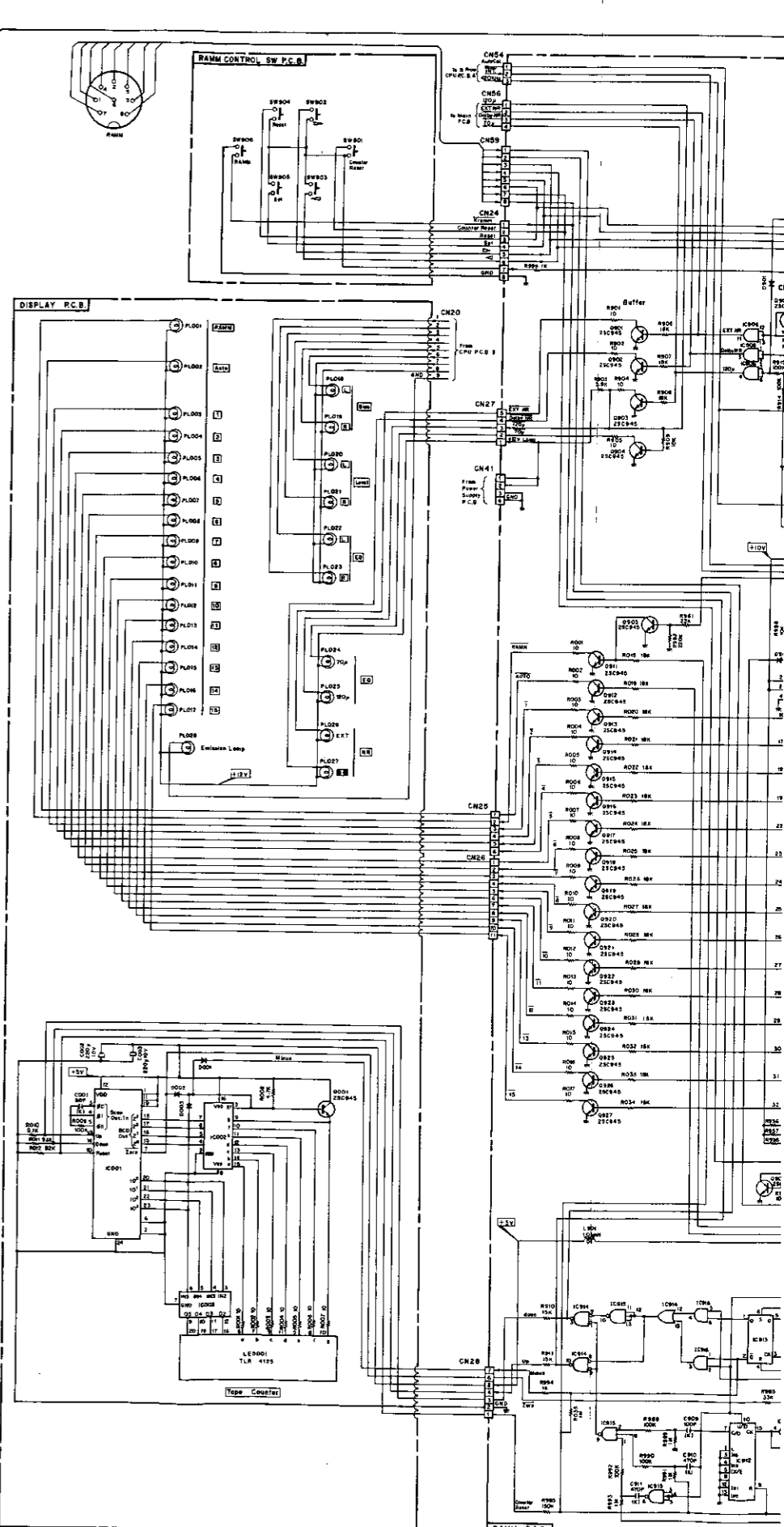
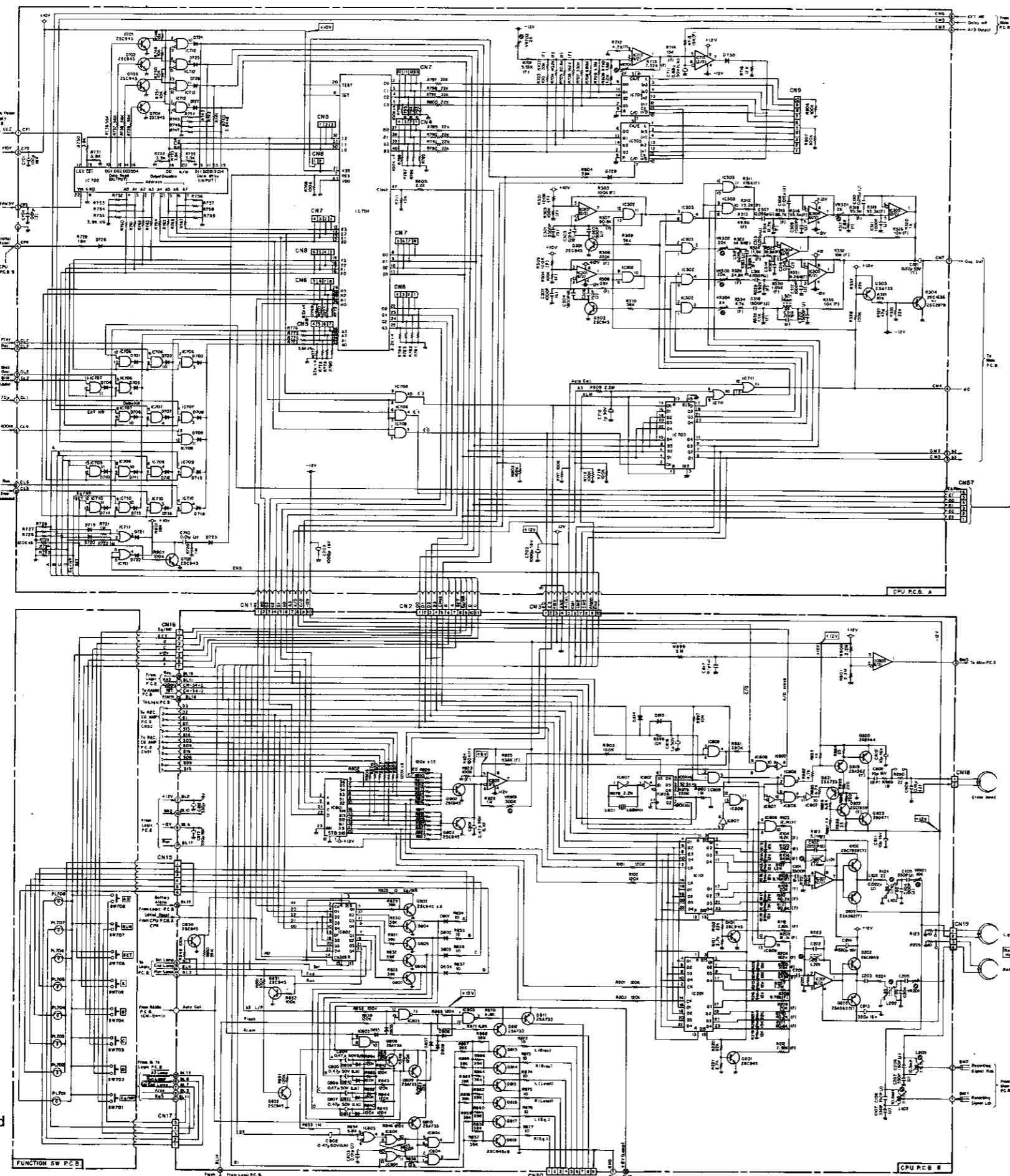

- Notes:
1. Diode is 1S553, 1S953, or 1S1555 unless otherwise specified.
 2. Resistor and capacitor marked with * show typical value.

Fig. 4.2

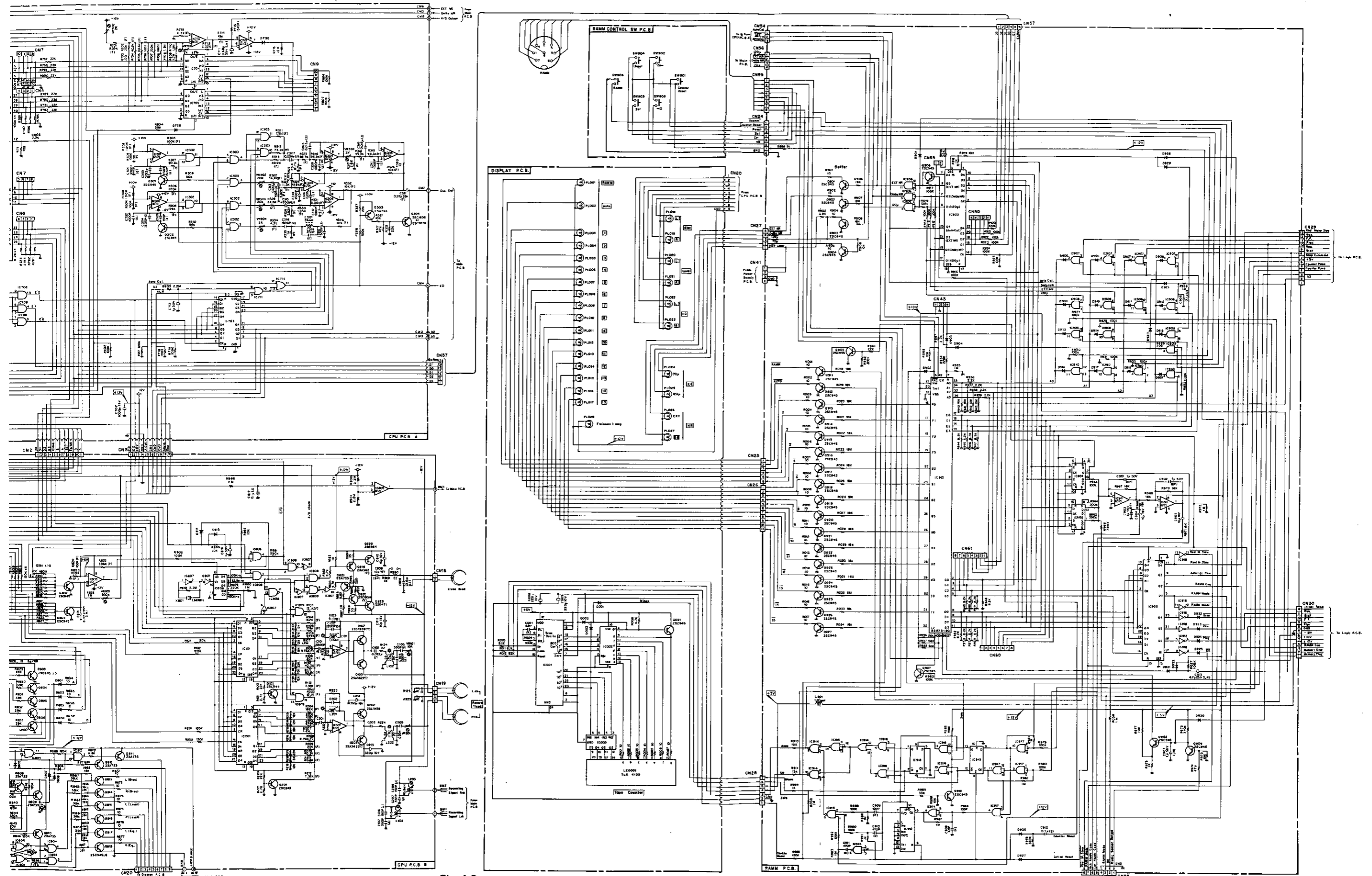
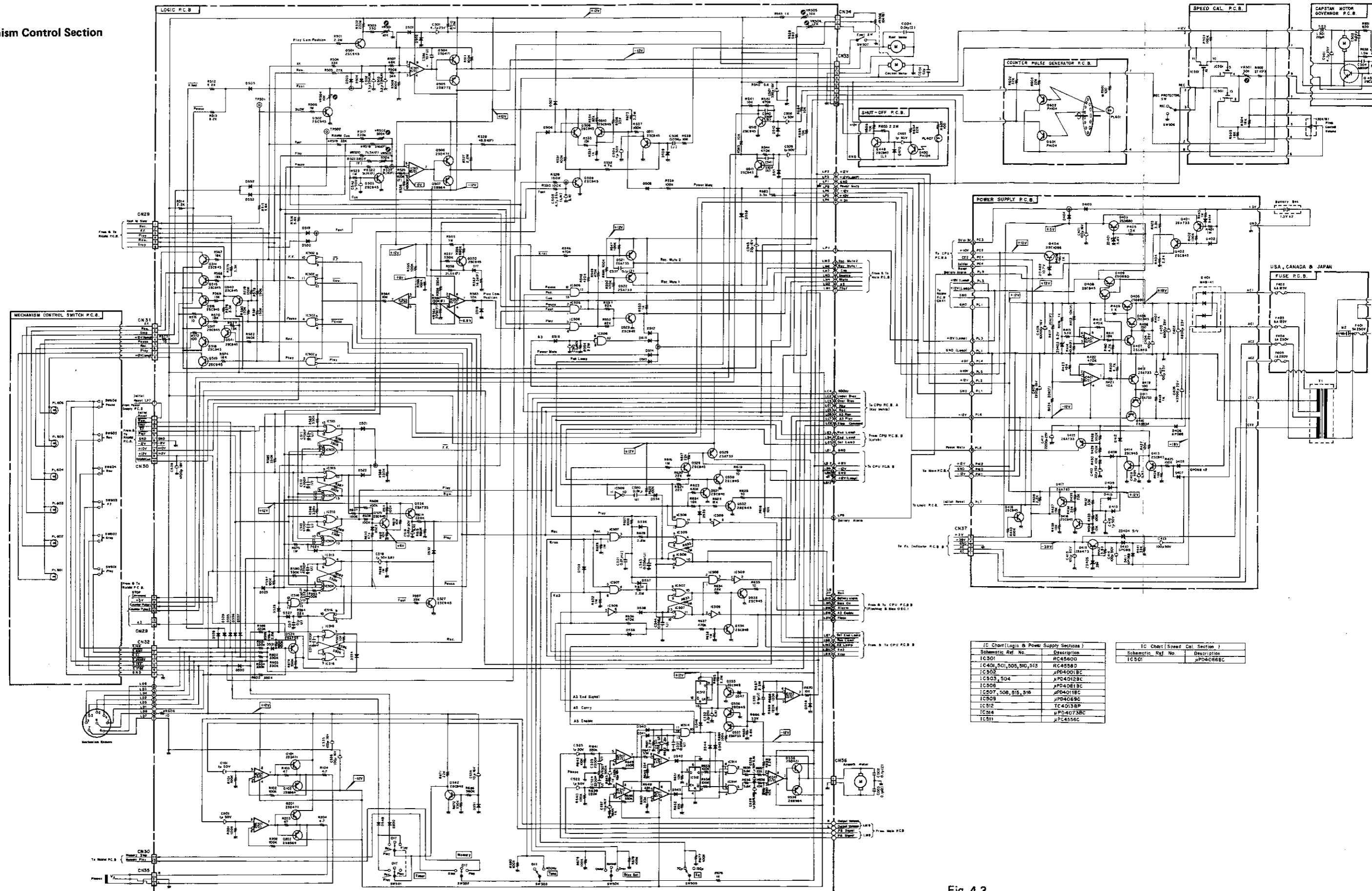

Fig. 4.2

4.4. Mechanism Control Section



IC Chart (Logic & Power Supply Sections)

Schematic Ref. No.	Description
IC501	RC4560D
IC401, 501, 505, 510, 515	RC455D
IC502	JPD40018C
IC503, 504	JPD40128C
IC506	JPD40818C
IC507, 508, 516, 518	JPD40118C
IC509	JPD4059C
IC512	TC40138P
IC514	JPD40738C
IC511	JPC4556C

IC Chart (Speed Cal. Section)

Schematic Ref. No.	Description
IC501	JPD4066C

Fig. 4.3

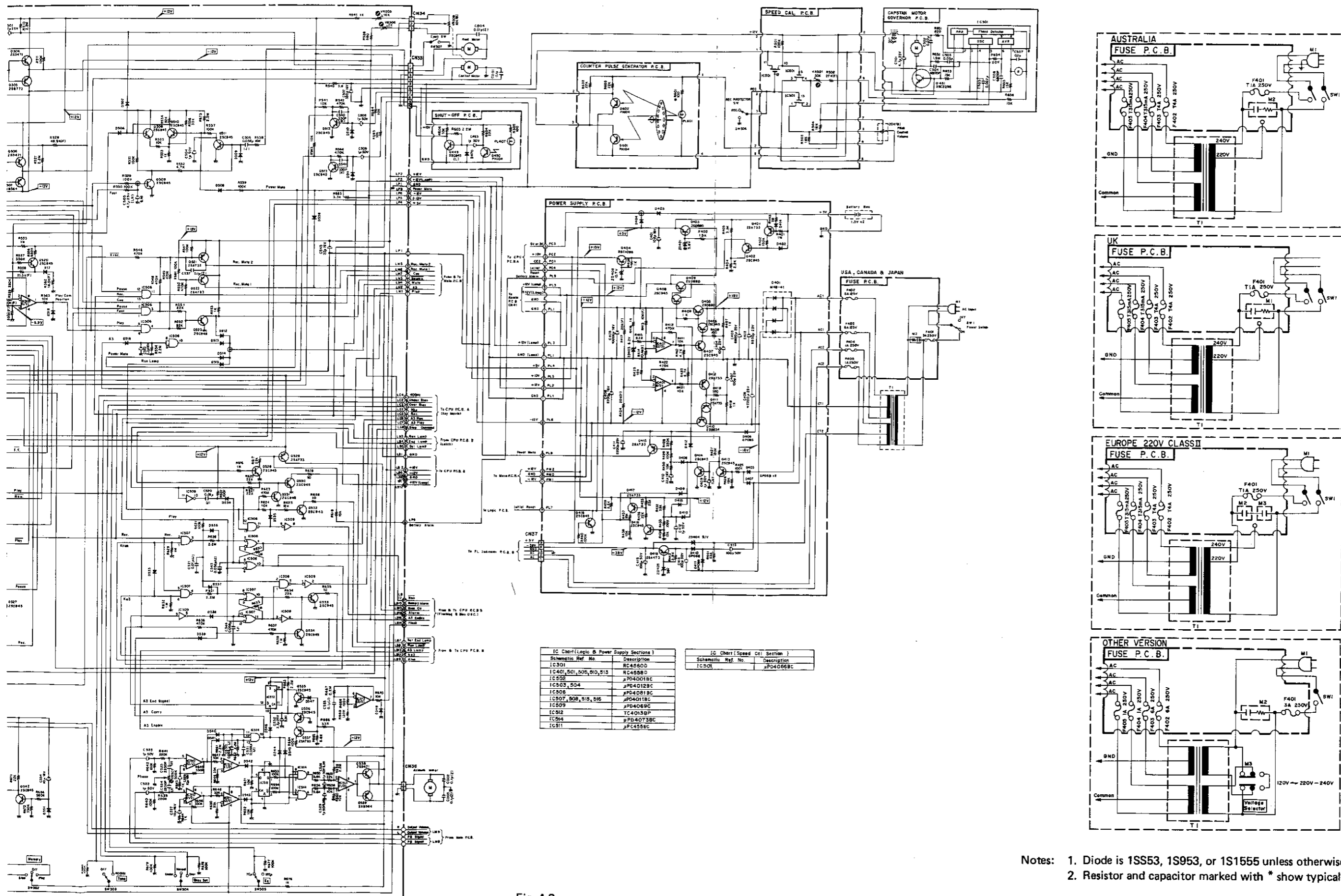

Fig. 4.3

Notes: 1. Diode is 1S553, 1S953, or 1S1555 unless otherwise specified.
 2. Resistor and capacitor marked with * show typical value.

5. SPECIFICATIONS

Power Source	100, 120, 120/220-240, 220 or 240 V AC; 50/60 Hz (According to country of sale)
Power Consumption	65 W max.
Tape Speed	1-7/8 ips (4.75 cm/sec)
Wow and Flutter	Less than 0.04% wtd rms Less than 0.08% wtd peak
Frequency Response (w. A.B.L.E.)	20–20,000 Hz ± 0.75 dB (18–25,000 Hz ± 3 dB) Nakamichi EX, EXII, SX, ZX tape Recording level –20 dB
Signal to Noise Ratio	Dolby B-Type NR in <70 μ s, ZX tape> Better than 66 dB (400 Hz, 3% THD, IHF A-wtd rms) Dolby C-Type NR in/using supplied NR-100 unit <70 μ s, ZX tape> Better than 72 dB (400 Hz, 3% THD, IHF A-wtd rms)
Total Harmonic Distortion	Less than 0.8% (ZX tape) Less than 1.0% (SX, EXII tape) (400 Hz, 0 dB)
Erasure	Better than 60 dB (100 Hz)
Separation	Better than 37 dB (1 kHz, 0 dB)
Crosstalk	Better than 60 dB (1 kHz, 0 dB)
Bias Frequency	105 kHz
Input (Line)	50 mV, 50 k ohms
(Microphone)	0.2 mV, 10 k ohms
(Noise Reduction)	100 mV, 50 k ohms
Output (Line)	1 V (400 Hz, 0 dB, output level control at max.)
(Headphones)	45 mW (400 Hz, 0 dB, output level control at max.)
(Noise Reduction)	100 mV, 2.2 k ohms
Dimensions	527 (W) x 264 (H) x 332 (D) millimeters 20-3/4 (W) x 10-25/64 (H) x 12-43/64 (D) inches
Approximate Weight	19.5 kg 43 lb.

Specifications of NR-100

Dimensions	120 (W) x 41 (H) x 240 (D) mm 4-23/32 (W) x 1-5/8 (H) x 9-7/16 (D) inches
Weight	Appr. 880 g 1 lb. 15 oz
Cable Length	70 cm, 27-1/2 inches

- Specifications and appearance design are subject to change for further improvement without notice.
- Dolby NR under license from Dolby Laboratories Licensing Corporation.
- The word "DOLBY" and the Double-D-Symbol are trademarks of Dolby Laboratories Licensing Corporation.