



Service Manual

Nakamichi 730 Receiver



CONTENTS

1.	General	4
2.	Principle of Operation	5
2. 1.	Fundamental Circuits	5
2.1.1.	C-MOS IC	5
	(1) Features of C-MOS IC	5
	(2) Gate Logic	6
	(3) Gated Flip-Flop	7
	(4) Ripple Counter	7
2.1.2.	Touch Switch	7
2.1.3.	5-Way Switch	8
2.1.4.	Bilateral Switch	8
2.1.5.	Operational Amplifier IC	8
	(1) Voltage Follower Circuit	8
	(2) Amplifier Circuit	8
	(3) Oscillator (Astable Multivibrator)	9
	(4) Comparator	9
	(5) Peak Holding Circuit	9
2.1.6.	SAW Filter (Surface Acoustic Wave Filter)	9
2.1.7.	Quadrature Detector	10
2. 2.	Power Supply Section	11
2.2.1.	Power Supply and Power Mute Signal	11
2.2.2.	Power Lamp and Back-up by Dry Cell Battery	12
2. 3.	Function Selectors	13
2.3.1.	Function Selectors	13
2.3.2.	Operation through Remote Controller	13
2.3.3.	Tape Monitor	13
2.3.4.	Change-over to Tape/Source	13
2.3.5.	Function Sensors	13
2.3.6.	Stereo/Mono Sensor	14
2.3.7.	Dolby FM, Hi-blend and FM Mute Sensor	14
2.3.8.	Audio Mute Sensor	14
2.3.9.	Volume Motor Control	14
2. 4.	Tuner Section	15
2.4.1.	FM MPX Stereo Broadcasting Operation	15
2.4.2.	Operation of Tuner Section	15
2.4.3.	Tuning System	17
	(1) Varicon Voltage	17
	(2) Motor Drive Circuit and Frequency Sensor (Motor Drive Detection Circuit)	17
	(3) Preset Tuning	18
	(4) Station Detecting Circuit (FM Out Signal)	19
	(5) Auto-Tuning	19
	(6) Tuning Lamps	21
	(7) FM Mute and Compulsion Mono	23
2. 5.	Amplifier Section	23
2.5.1.	Phono Eq. Amplifier	23
2.5.2.	Recording Output Buffer Amplifier	23
2.5.3.	Output Buffer Amplifier	24
2.5.4.	Tone Control	24
2.5.5.	Power Amplifier	25
	(1) Pre-stage (Voltage Amplifier)	25
	(2) Output Stage (Power Amplifier)	25
	(3) Limiter	27
2.5.6.	Protector Circuit	28
2. 6.	Remote Control Unit RM-730 (Optional)	29
2.6.1.	Introduction	29
2.6.2.	Transmitter	29

	(1) Matrix Key	29
	(2) System IC for Transmission	29
	(3) LED Driver	29
2.6.3.	Receiver	30
	(1) Signal Input	30
	(2) Signal Amplifier	30
	(3) System IC for Reception	30
	(4) Instantaneous Power-disconnecting Switch	30
	(5) Buffer Amplifier	31
	(6) Information Processor	31
3.	Removal Procedures	32
3. 1.	Side Panel R	32
3. 2.	Top Cover Ass'y Bottom Cover A, Bottom Cover B, Bottom Cover C and Battery Cover Ass'y ..	32
3. 3.	Front Panel Ass'y	33
3. 4.	Volume Lamp P.C.B. Ass'y	33
3. 5.	Lamp P.C.B. Ass'y	33
3. 6.	Lamp Cover Ass'y	33
3. 7.	Logic L Ass'y and Logic R Ass'y	33
3. 8.	Function Sensor P.C.B. Ass'y	34
3. 9.	Tuning Sensor P.C.B. Ass'y	34
3. 10.	Dolby NR P.C.B. Ass'y, Main P.C.B. Ass'y, Tuning Logic P.C.B. Ass'y, IF P.C.B. Ass'y, Tuning Lamp P.C.B. Ass'y, Volume P.C.B. Ass'y and Motor Base Ass'y (Volume)	34
3. 11.	Rear Panel Ass'y, Push Terminal, Remote Control Socket Ass'y, Record Output Volume Ass'y, 2P Terminal, Attenuator Switch Ass'y, Balun Transformer and Ground Terminal	35
3. 12.	Protector P.C.B. Ass'y, Power Transformer, Sub Transformer, Power Relay, Capacitor P.C.B. Ass'y, Power Supply P.C.B. Ass'y and Power Box	36
3. 13.	Fuse P.C.B. Ass'y, Power Cord, Power Switch, AC Outlets and Power Supply Panel	36
3. 14.	Side Panel, Power Block Ass'y, Thermal Transistor Ass'y, Output P.C.B. Ass'y, Power Amp. P.C.B. Ass'y, Transistor 2SB600, Transistor 2SD555, Heat Sink and Power Block P.C.B. Insulator	37
3. 15.	Front-end Reel Ass'y, Motor Base Ass'y (Front-end), Pulley Holder and Front-end 730	37
4.	Adjustments and Measurements	38
4. 1.	FM Tuner Section	38
4.1.1.	Electrical Adjustments and Measurements	38
4.1.2.	Auto-Return Scale Calibration	44
4.1.3.	Auto-Tuning Calibration	44
4. 2.	Preamplifier Section	44
4.2.1.	Preamplifier Eq. Adjustment	44
4.2.2.	Signal-to-Noise Ratio Measurement	44
	(1) Phono Input/Recording Output	44
	(2) Aux. Input/Preamp. Output	44
4.2.3.	Distortion Measurement	45
	(1) Phono Input/Recording Output	45
	(2) Aux. Input/Preamp. Output	45
4. 3.	Power Amplifier Section	45
4.3.1.	Idling Current Adjustment	45
5.	Threading	46
5. 1.	Dial Threading	46
5.1.1.	How to prepare Dial Thread	46
5.1.2.	How to fit Front-end Reel Ass'y	46
5.1.3.	How to set Dial Threading	47
5.1.4.	How to assemble Lamp Base Ass'y with Dial Thread	47
5. 2.	Volume Controller Threading	48
5.2.1.	How to prepare Volume Controller Thread	48
5.2.2.	How to set Volume Controller Threading	48
5.2.3.	Volume Scale Calibration	50

6. Mounting Diagram and Parts List	51
6. 1. Main P.C.B. Ass'y	52
6. 2. IF P.C.B. Ass'y	53
6. 3. Dolby NR P.C.B. Ass'y (Optional)	53
6. 4. Function Sensor P.C.B. Ass'y	54
6. 5. Tuning Sensor P.C.B. Ass'y	55
6. 6. Tone Control P.C.B. Ass'y	55
6. 7. Lamp P.C.B. Ass'y	55
6. 8. Preset P.C.B. Ass'y	57
6. 9. Tuning Logic P.C.B. Ass'y	57
6. 10. Power Block Ass'y	59
6.10.1. Power Amp. P.C.B. Ass'y	59
6.10.2. Output P.C.B. Ass'y	59
6. 11. Protector P.C.B. Ass'y	61
6. 12. Headphone P.C.B. Ass'y	61
6. 13. Fuse P.C.B. Ass'y	61
6. 14. Capacitor P.C.B. Ass'y	61
6. 15. Volume Lamp P.C.B. Ass'y	62
6. 16. Tuning Lamp P.C.B. Ass'y	62
6. 17. Volume P.C.B. Ass'y	62
6. 18. Power Supply P.C.B. Ass'y	63
7. Mechanism Ass'y and Parts List	64
7. 1. Synthesis	64
7. 2. Synthesis Mechanism 730 (A01)	65
7. 3. Main Chassis Ass'y (B01)	66
7. 4. Front Panel Ass'y (B02)	68
7. 5. Side Panel Ass'y 730 (B03)	68
7. 6. Rear Panel Ass'y (B04)	69
7. 7. Main Chassis Sub Ass'y (C01)	69
7. 8. Power Supply Ass'y (C02)	70
7. 9. Volume Control Ass'y (C03)	71
7. 10. Front-end Control Ass'y (C04)	72
7. 11. Lamp Base Ass'y (C05)	72
7. 12. Power Block Ass'y 730 (D01)	73
7. 13. Power Panel Ass'y (E01)	73
7. 14. Motor Base Ass'y (Front-end) (F01) and Motor Base Ass'y (Volume) (F02)	73
8. Performance Data	75
9. Block Diagrams	77
9. 1. Tuner Section	77
9. 2. Amplifier Section	78
10. Schematic Diagrams	79
11. Wiring Diagram	82
12. Remote Controller RM-730 (Optional)	83
12. 1. Schematic Diagrams	83
12.1.1. Transmitter	83
12.1.2. Receiver	83
12. 2. Mounting Diagrams and Parts List	83
12.2.1. Transmitter	83
12.2.2. Receiver	84
12. 3. Adjustments	85
12.3.1. Transmitter	85
12.3.2. Receiver	85
12.3.3. Performance Check of Transmitter and Receiver	85
12. 4. Mechanism Ass'y and Parts List	86
12.4.1. Transmitter	86
12.4.2. Receiver	87
13. Specifications	88

1. GENERAL

Nakamichi 730 control functions are shown below:

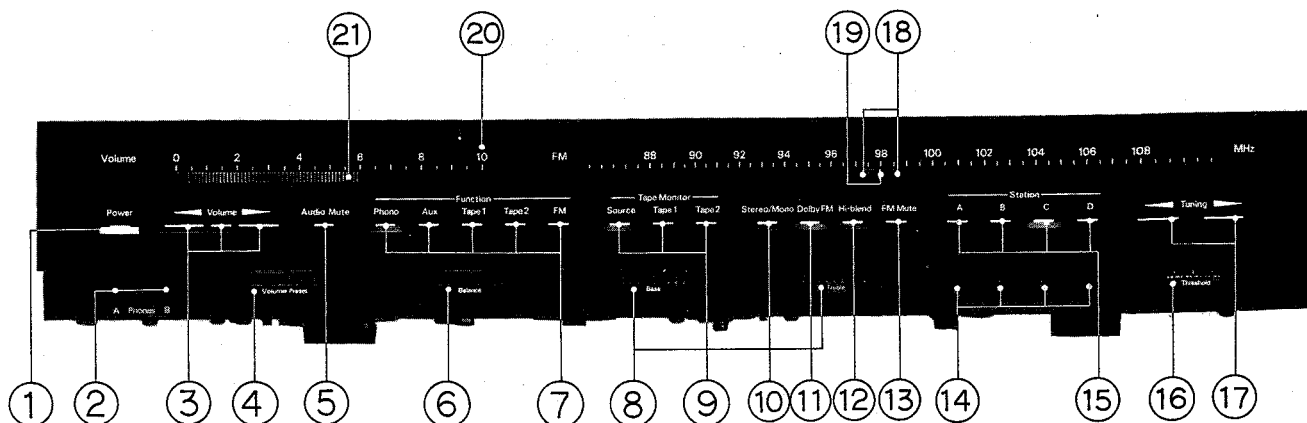

Fig. 1.1 Front View

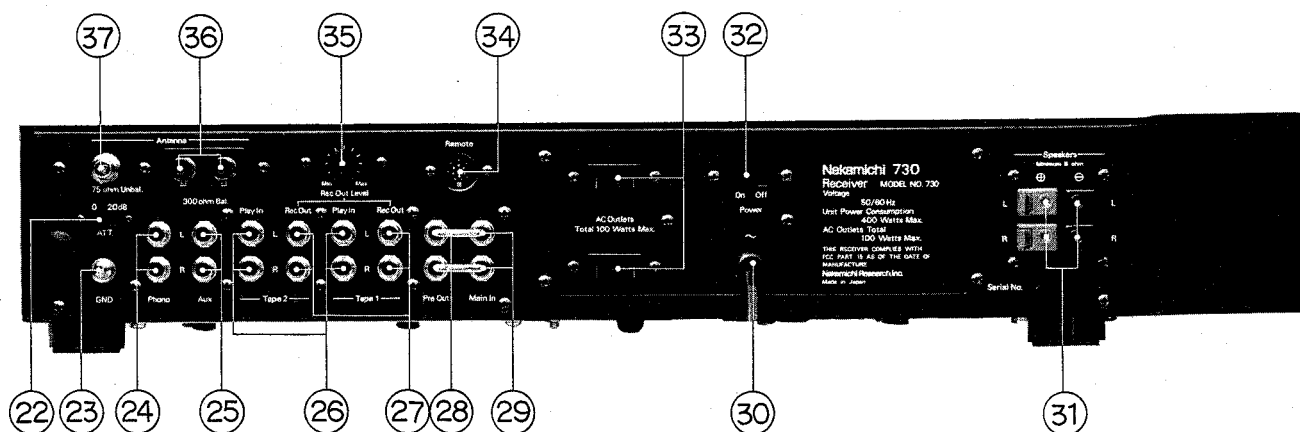

Fig. 1.2 Rear View

- | | |
|--|--|
| 1. Power Sensor | 20. Volume Scale |
| 2. Headphone Jacks A and B | 21. Volume Indicator |
| 3. Volume Control Sensors | 22. Attenuator Switch |
| 4. Volume Preset Control | 23. Ground Terminal |
| 5. Audio Mute Sensor | 24. Phono Input Jacks |
| 6. Balance Control | 25. Auxiliary Input Jacks |
| 7. Function Sensor Group
(Phono/Aux/Tape 1/Tape 2/FM) | 26. Tape 2 Playback Input Jacks,
Tape 1 Playback Input Jacks |
| 8. Tone Controls (Bass, Treble) | 27. Tape 2 Recording Output Jacks,
Tape 1 Recording Output Jacks |
| 9. Tape Monitor Sensor Group
(Source/Tape 1/Tape 2) | 28. Preamplifier Output Jacks |
| 10. Stereo Sensor | 29. Main Amplifier Input Jacks |
| 11. Dolby FM Sensor | 30. AC Power Cord |
| 12. Hi-Blend Sensor | 31. Left Channel Speaker Terminals,
Right Channel Speaker Terminals |
| 13. FM Mute Sensor | 32. Master Power Switch |
| 14. Station Preset Controls (A/B/C/D) | 33. AC Outlets |
| 15. Station Memory Sensors (A/B/C/D) | 34. Remote Jack |
| 16. Threshold Control | 35. Recording Output Level Control |
| 17. Tuning Sensors | 36. 300-ohm Balanced Terminals |
| 18. Tuning Lamps | 37. 75-ohm Unbalanced Connector |
| 19. Tuning Pointer | |

Notes: 1. Dolby NR P.C.B. Ass'y is an optional accessory to be ordered separately except for the U.S.A. version.

2. For other versions, Voltage Selector is incorporated instead of Master Power Switch at the Rear Panel. Voltage Selector provides changeover either to 120 V or 220 – 240 V.

If you desire to cut off the entire AC power source to the N-730, unplug the AC Power Cord. Otherwise N-730 will be in stand-by mode with a condition of Power Cord plugged in.

Note: If battery is not incorporated or battery voltage is lower than approx. 4 V (battery alarm will be indicated by flickering the Power Lamp at either case), unplug of AC Power Cord causes clearance of function memories. Therefore re-set of functions will be required after plugging the AC Power Cord and further touch-commanding the Power Sensor to turn ON the power.

2. PRINCIPLE OF OPERATION

2.1. Fundamental Circuits

2.1.1. C-MOS IC

(1) Features of C-MOS IC

The IC's used in the logic circuit of the N-730 are of the C-MOS (complementary metal oxide semiconductor) type, in which P-channel and N-channel MOS FET's complement each other.

(a) Small power consumption

A C-MOS is an inverter, as shown in Fig. 2.1.1.

Whether the input of this inverter is at H or L level, either the P-channel or N-channel MOS FET is OFF, and therefore, current does not pass from VDD to VSS under steady normal state. Consequently, when there is no input, power consumption ($VDD \times I_{DD}$) is nearly zero, except for surface and junction leakage.

When the input signal is switched from H to L, or L to H, however, both P- and N-channel FET's instantly come on, and a current flows either charging or discharging the stray output capacity, so that the power consumption during dynamic operation cannot be said to be zero.

(b) A large noise margin

The input-output transmission characteristics of the C-MOS inverter differ from those of bipolar IC's as shown in Fig. 2.1.2. The knee characteristic is sharper, the threshold voltage is almost half of VDD, and the output amplitude is nearly equal to $VDD - VSS$.

Since the noise margin of a digital IC is defined as the difference between the minimum value of output amplitude and the minimum required amplitude of the input signal, it is quite natural that the C-MOS circuit, which produces an output amplitude of nearly $VDD - VSS$ and is operated by a small input signal, should have a large noise margin.

(c) High input impedance

A C-MOS IC has a very high input impedance because it is insulated from the substrate by the oxide film of the gate. Although leakage resistance must be considered in an

actual C-MOS IC because diodes are usually used in the direction of reverse bias for protecting input circuit, its impedance is several tens of megohms. The advantage of a high input impedance is that the fan-out of the IC is large, which simplifies the interface. Also, a timer circuit for a longer period of time can be produced. This means that the high input impedance enables the input to be connected with a large resistance, but does not mean to use a capacitor of large capacity.

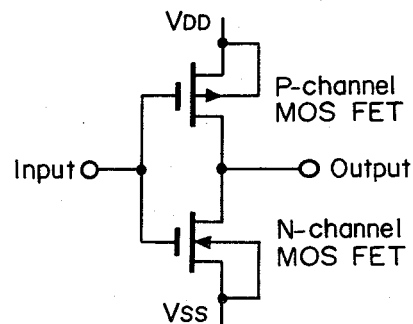

Fig. 2.1.1 C-MOS Inverter

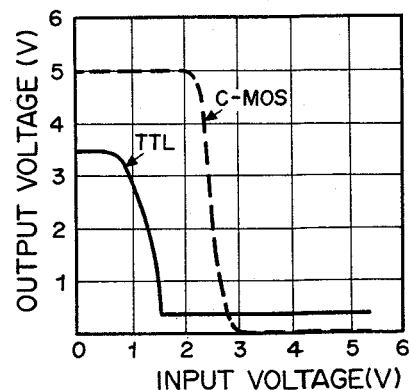

Fig. 2.1.2 Input-Output Transmission Characteristics

(d) Wide operating voltage range

Fig. 2.1.3 shows input-output transfer characteristics of C-MOS. The general purpose C-MOS family has a wide operating voltage range extending from 3 to 18 V, which is much wider than that of TTL and DTL (5 ± 0.25 V), and HTL (15 ± 1.5 V). The reason for the C-MOS IC's wide operating voltage range is that the P-MOS and N-MOS are made symmetrical, and if VDD is varied, the threshold voltage for the circuit is always about half of VDD. In a bipolar IC, the threshold voltage is decided by the forward voltage from the base to the emitter of the transistor (VBE), and is little affected by the source voltage. Therefore, if the source voltage exceeds a certain limit, the output voltage and the threshold voltage will not balance, as a result of which operation will become impossible.

With a C-MOS, the threshold voltage varies according to changes in the source voltage, and stable operation throughout a wide range can be expected. As indicated above, the performance of a C-MOS IC as a digital IC is excellent.

(2) Gate Logic

NOR gate is used. The inputs IN1 and IN2, and the output from the gate is shown below:

The output will be H only if IN1 and IN2 are L's, and the output will be L if IN1 is H or IN2 is H. (H: +13 V, L: 0 V)

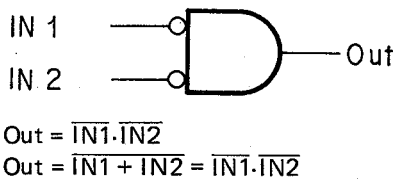
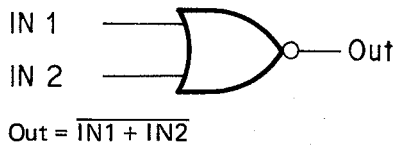

Fig. 2.1.4 NOR Gate

Truth Table 1

IN1	IN2	Out
L	L	H
L	H	L
H	L	L
H	H	L

The construction of the foregoing 2 Logic Symbols is identical and intended to show the use of either OR or AND.

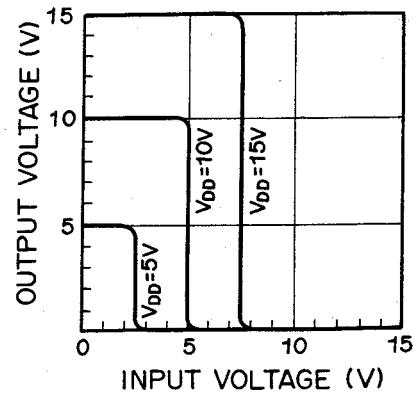

Fig. 2.1.3 Input-Output Transfer Characteristics of C-MOS (The threshold voltage is approximately half of VDD.)

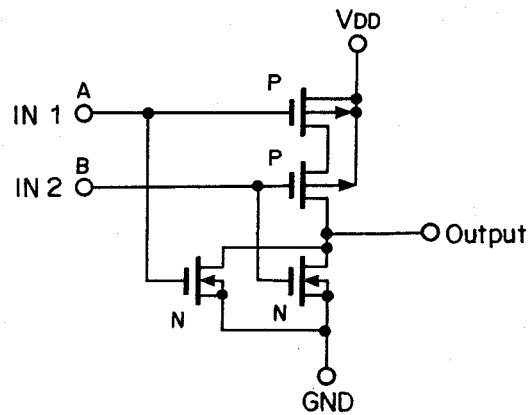

Fig. 2.1.5

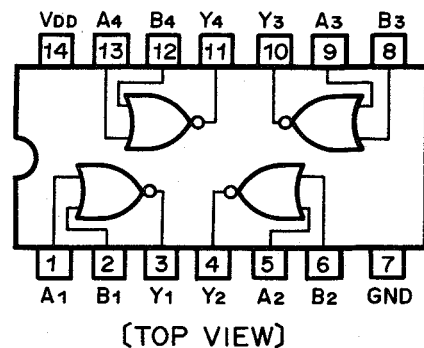

Fig. 2.1.6

(3) Gated Flip-Flop

The two NOR gates can be used to form a flip-flop as shown in Fig. 2.1.7. The inputs operate as follows:

When both S and R are L's, the flip-flop will remain in its present state, i.e., will not change states. If however, the R input goes to H, the NOR gate connected to R will have L output regardless of the other feedback input to the NOR gate, and this will force the flip-flop to the H state (provided the S input is kept L). Similar reasoning shows that making the S input H will cause the NOR gate at the S input to have L output, forcing the flip-flop to the L state (again provided the R input is kept L).

If both inputs R and S are made H's, the next state will depend on which input is returned to L first, and if both are returned to L simultaneously, the resulting state of the flip-flop will be indeterminate. As a result, this is a "forbidden", or "restricted", input combination.

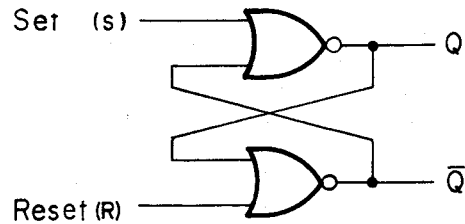

Fig. 2.1.7

Truth Table 2

Set	Reset	Q	Q̄	Remarks
L	L	*	*	*: Maintains the previous state.
L	H	H	L	
H	L	L	H	
H	H	L	L	

(4) Ripple Counter

When switches alternating between two states are necessary, for example, for the power switch and the audio muting switch, the N-730 uses ripple counters (flip-flops), as showing Fig. 2.1.8. In this circuit, when the output Q is H and the other output Q̄ is L, both inputs of the NOR gate A are L and the inputs of the NOR gate B are H and L, and these states are stored. The voltage between the two ends, of the capacitor CA is 0 V, and the capacitor CB is charged because one end is H and the other L (see levels in the figure). When the switch is turned ON and a pulse voltage is impressed, CA is charged and H is supplied to one input of the NOR gate A. The output Q then becomes L, which is supplied to one of the input terminals of the NOR gate B, changing the output Q̄ from L to H.

When this switch is pressed, the levels of output Q and Q̄ are alternated. This circuit is known as a ripple counter.

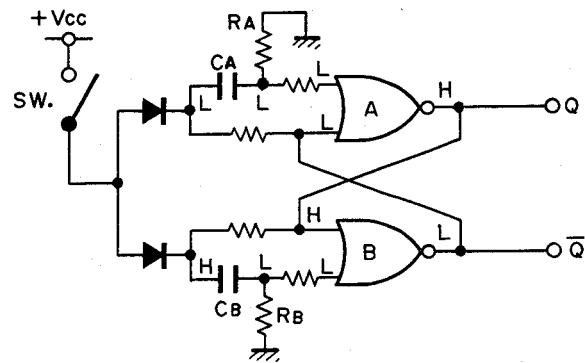

Fig. 2.1.8 Ripple Counter

2.1.2. Touch Switch

See Fig. 2.1.9. When the sensor and the ground of the touch switch are connected through the resistance of the finger (several megohms) base current is supplied to a transistor. This can also be operated by hum.

Usually, a man has the same hum level as the surface of the earth. Since the N-730 is insulated from the earth with the power transformer, hum is produced in the N-730. Therefore, when the sensor is touched with the finger, a current flows and a signal is emitted. This signal, however, contains a hum component disturbing the operation of the circuit. Therefore, the hum component is eliminated with a capacitor to convert it into a DC signal.

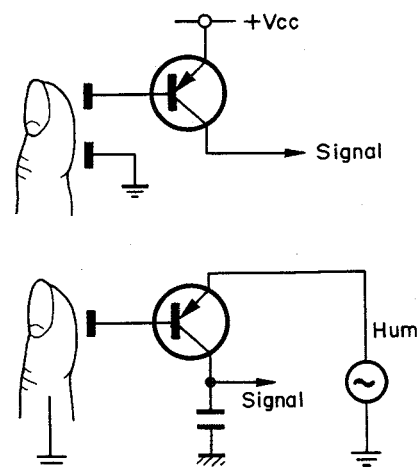

Fig. 2.1.9 Touch Switch

2.1.3. 5-Way Switch

In the N-730, a circuit is provided to reset the other functions when the Phono, Aux, Tape 1, Tape 2, or FM function is selected as shown in Fig. 2.1.10. This circuit consists of flip-flop circuits corresponding to each mode, and a diode matrix. When one mode is selected, a signal is input to the Set terminal of the flip-flop for desired mode. This signal is sent to the Reset terminals of the other flip-flops through diodes, thus resetting them.

Electronic switches using the combination of a diode matrix and flip-flop circuits are used also as the 3-way switch of the tape monitor and the 6-way switch of the FM station in the N-730.

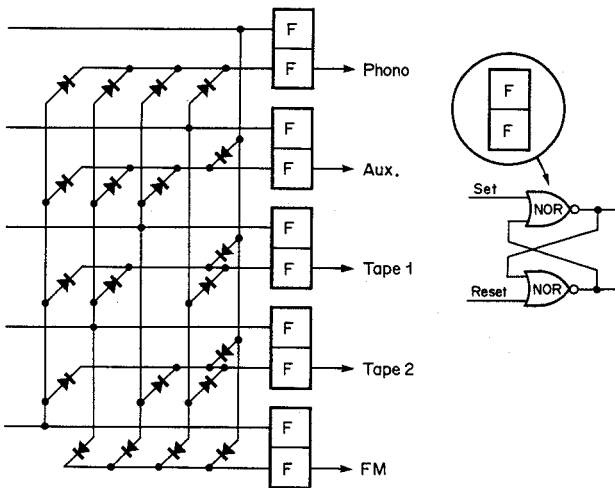

Fig. 2.1.10 5-Way Switch

2.1.5. Operational Amplifier IC

Most operational amplifier IC's consist of a differential amplifier with a voltage amplification of 70 to 100 dB. High-gain amplifier circuits, oscillators or comparators use operational amplifier IC.

$$(V_{in} - V_{in(-)}) \times A_v = V_{out}$$

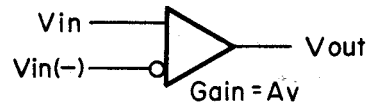

Fig. 2.1.12 Operational Amplifier

(1) Voltage follower circuit

This circuit is a special-purpose non-inverting amplifier. It is used for converting impedance when the impedance of the input signal source is too high and the input impedance of the following step is too low for direct connection. The special feature of the voltage follower is high input impedance and low output impedance. Its voltage gain is 1.

$$(V_{in} - V_{out}) \times A_v = V_{out}$$

$$V_{in} = \frac{V_{out}}{A_v} + V_{out} = V_{out} \left(1 + \frac{1}{A_v}\right) \approx V_{out}$$

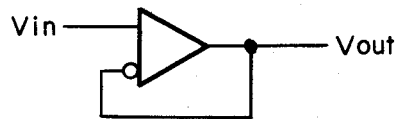

Fig. 2.1.13 Voltage Follower Circuit

(2) Amplifier circuit

Two types of amplifier circuits are the inverting amplifier and the non-inverting amplifier. The amplification factor of these circuits is $\frac{R_1 + R_2}{R_2}$.

Inverting circuits output signals of phases opposite to those of the input signals.

$$(V_{in} - V_{out} \frac{R_2}{R_1 + R_2}) \times A_v = V_{out}$$

$$V_{in} = \frac{V_{out}}{A_v} + V_{out} \frac{R_2}{R_1 + R_2}$$

$$= V_{out} \left(\frac{1}{A_v} + \frac{R_2}{R_1 + R_2} \right)$$

$$\approx V_{out} \frac{R_2}{R_1 + R_2} \quad (\because \frac{1}{A_v} \approx 0)$$

$$V_{out} = V_{in} \frac{R_1 + R_2}{R_2}$$

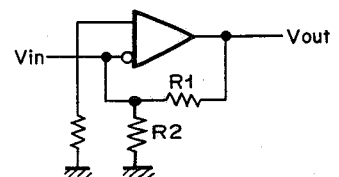
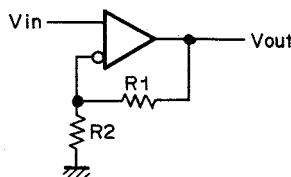

Fig. 2.1.14 Non-inverting

Fig. 2.1.15 Inverting

2.1.4. Bilateral Switch

In conventional models, the change-over of functions is made with push-button switches or rotary switches. In the N-730, it is done by turning ON or OFF the gate of a quad bilateral switch IC, TC4066BP and μ PD4066, operated by the function switch described in 2.1.3. the equivalent circuit of the TC4066BP and μ PD4066 element, as shown in Fig. 2.1.11, is a control switch operated by logic signals. Because of the C-MOS's structure, the signal line is little affected by the control input, and the ON resistance varies little with the signal inputs. This switch has a wide application, for example in choppers, modulators and demodulators.

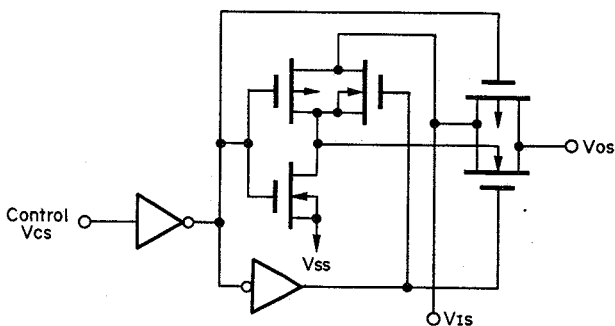

Fig. 2.1.11 Bilateral Switch

(3) Oscillator (Astable Multivibrator)

The operational amplifier amplifies the difference between non-inverting input and inverting input, and generally its output is amplified up to the source voltage because of the high voltage amplification.

In the circuit shown in Fig. 2.1.16, V_{out} equals the positive source voltage when the non-inverting input is larger than the inverting input. The voltage of the non-inverting input is $\frac{R_2}{R_2 + R_3}$ of the positive source voltage. On the other hand, because C_1 is charged by the V_{out} voltage through R_1 , the inverting input rises to the positive source voltage. However, when it exceeds the voltage of the non-inverting input, V_{out} is inverted to the negative source voltage. The voltage of the non-inverting input then is $\frac{R_2}{R_2 + R_3}$ of the negative source voltage. When C_1 is discharged through R_1 and the voltage of the inverting input becomes lower than that of the non-inverting input, V_{out} is again inverted to the positive source voltage. By repeating these operations, the circuit acts as an astable multivibrator. See Fig. 2.1.17 timing chart.

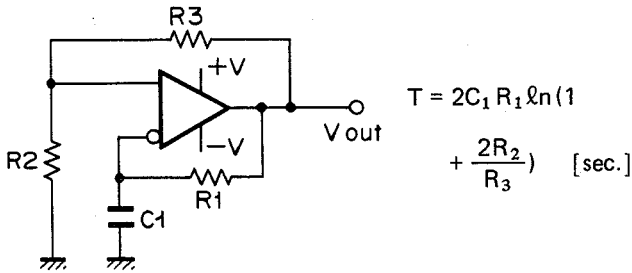

Fig. 2.1.16 Oscillator

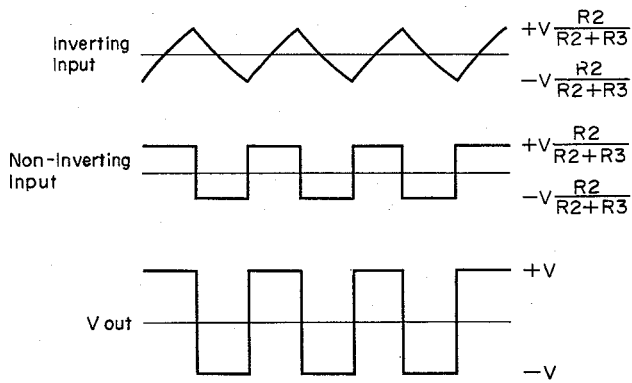

Fig. 2.1.17 Timing Chart

(4) Comparator

The comparator is composed of ordinary operational amplifier IC's or comparator IC's. Two types of comparator IC's are those with open collector output and those with ordinary output. The N-730 uses a comparator IC having open collector output. Normally, it acts as an ordinary operational amplifier IC.

(5) Peak holding circuit

Figs. 2.1.18 and 2.1.19 show the peak holding circuit for positive input voltage and its timing chart.

This circuit holds the peak value of the input voltage. When the input signals are pulses, the capacitor C repeatedly charges and discharges to hold the peak value. When no pulse is supplied, C is discharged through R and the output becomes 0 with a certain time constant. It is used in the N-730 in combination with an oscillator for frequency-voltage conversion.

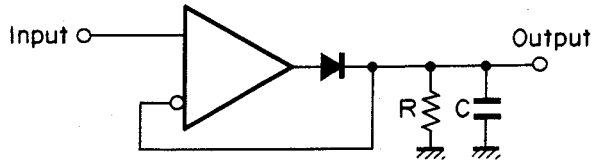

Fig. 2.1.18 Peak Holding Circuit

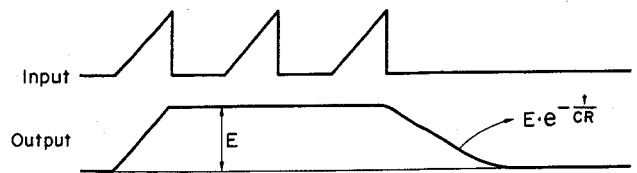

Fig. 2.1.19 Timing Chart

2.1.6. SAW Filter (Surface Acoustic Wave Filter)

Fig. 2.1.20 shows the occurrence of surface acoustic waves, and Fig. 2.1.21 shows the concept of the SAW filter. When comb-like electrodes are formed on a piezo-electric element as shown in Fig. 2.1.20 (a), and a signal is applied, an electric field as shown in Fig. 2.1.20 (b) is produced, and displacement as shown in Fig. 2.1.20 (c) occurs on the surface of the piezo-electric substrate. By this continuously varying displacement, surface acoustic waves are driven and propagated in both directions. In the receiver, if electrodes of the same comb shapes are placed on a piezo-electric substrate as shown in Fig. 2.1.21, the electric signal is received in reverse order (i.e. displacement → generation of electric field → output signal). The center frequency of this filter is determined by the acoustic velocity for the piezo-electric substrate, V_s , and the electrode distance of the inter-digital transducer (IDT), λ_1 .

$$f_0 = V_s / \lambda_1 \text{ [Hz]}$$

On the other hand, the band width, B , is proportional to the reciprocal of the number of electrodes of the IDT, i.e., $B \propto 1/N$, and decreases as the number of electrodes increases.

Although the basic structure of the SAW filter is a normal type transducer, that of the apodised type as shown in Fig. 2.1.22 or chirped FM type as shown in Fig. 2.1.23 may be used to give improved characteristics. The

apodised-type transducer has electrodes of different length which are equally spaced. It has improved side lobe characteristics as well as decreasing the ripples of amplitude and of group delay frequency characteristics. The charped FM-type transducer has electrodes of same length unequally spaced.

Fig. 2.1.24 shows the characteristics of a SAW filter using an apodised IDT.

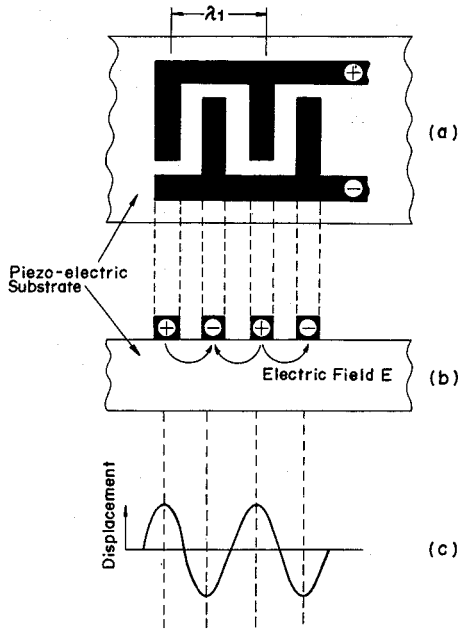

Fig. 2.1.20 Occurrence of Surface Acoustic Waves

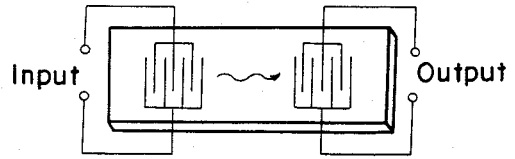

Fig. 2.1.21 Model of SAW Filter

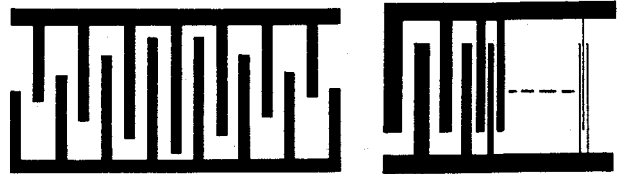

Fig. 2.1.22 Apodised

Fig. 2.1.23 Charped FM

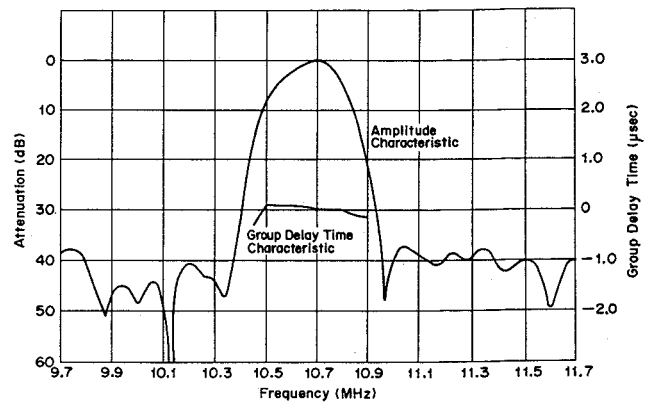

Fig. 2.1.24 Characteristics of SAW Filter (Apodised IDT)

2.1.7. Quadrature Detector

Figs. 2.1.25–2.1.27 show the structure and operation principle of the quadrature detector. It is a phase detector in which a direct signal is supplied to an input terminal of the multiplier, and a signal through a 90° phase shifter is

supplied to another. The pulse width of output i_L varies according to the phase difference between the direct input e_1 and the input through the phase shifter e_2 and phase detection is made by the increase and decrease of the mean value $i_{average}$.

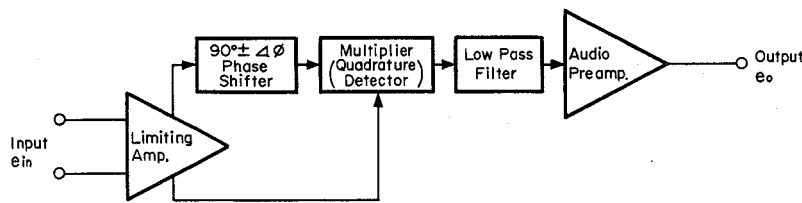

Fig. 2.1.25 Quadrature Detector System Diagram

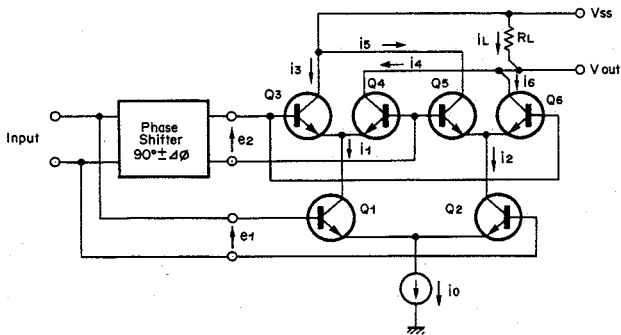

Fig. 2.1.26 Quadrature Detector Circuit

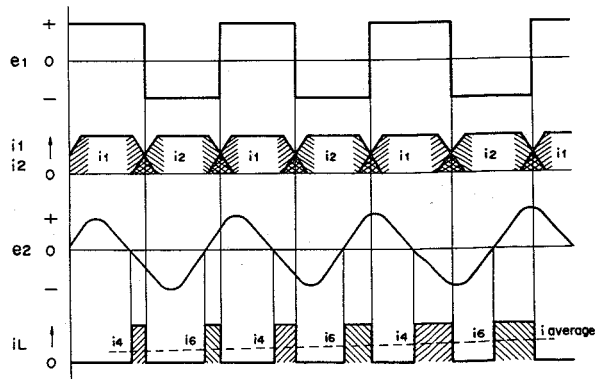

Fig. 2.1.27 Timing Chart

2.2. Power Supply Section

2.2.1. Power Supply and Power Mute Signal

Refer to the Timing Chart in Fig. 2.2.1.

(1) Master Power Switch ON

When the Master Power Switch at the Rear Panel is turned ON, +Sub A power source will be obtained at the Power Supply P.C.B. via Sub-Transformer, which will set the N-730 in a stand-by condition. +Sub A enters the Tuning Logic P.C.B. and will become rated voltage of approx. +13 V at zener diode ZD801 through D810. This voltage is indicated to be +Sub B and will be supplied to the Power Sensor Circuit of the Function Sensor P.C.B. On the other hand, the voltage of approx. +13 V at ZD801 is expressed to be +13 V and will be fed, via D811, to the Function Sensor P.C.B. and Tuning Sensor P.C.B. and will be used as a power source of the C-MOS Flip-Flops.

(2) Power ON

Refer to Fig. 2.2.2, circuit diagram.

When the Power Sensor of the Front Panel is touch-commanded to power ON, ±12 V and ±55 V Power Source will be supplied. The Power Sensor, when commanded, will set the power Flip-Flop of the Function Sensor P.C.B. and will become IC501-11=H. As a result, Q502 will be turned ON to bring Relay Drive=L which will then enter the Power Supply P.C.B. via the Main P.C.B. and activates Relay RL1. When RL1 is turned ON, AC input will be supplied to Power Transformer. Thus Power Source of ±12 V and ±55 V will be secured.

In the meantime, when Q502 is turned ON, Q503 will become turned OFF. Accordingly C504 (22 μF 16V) will be charged via R510 (220 kΩ), then Q504 will be turned ON approx. 7 seconds later to release the Power Mute Signal. In other words the said Power Mute Signal will bring the N-730 in Mute condition approx. 7 seconds after the +12 V is supplied. Power Mute=H will enter the Mute Generator (Q309, Q308) of the Main P.C.B. and mutes each of the output terminals. It is also supplied to the Protector P.C.B. to turn OFF the Speaker Control Relay RL701 and opens the supply to Speaker System. When Power Mute Signal is released, RL701 becomes turned ON and Speaker System will be connected.

When the Power Sensor is again touch-commanded, the Power Flip-Flop will become reset, as a result of which IC501-11 becomes L and Q502 will be turned ON. This way, the above RL1 will turn OFF, AC input to the Power Transformer will cut off, and ±12 V and ±55 V will no longer be supplied.

When Q502 is turned OFF, Q503 will become turned ON. C504 will therefore immediately discharge via Q503. This way, Q504 will be turned OFF, and Power Mute=H will be supplied from +Sub B Power Source via R514. The N-730 will therefore be muted even while power-OFF by Power Sensor.

When Compulsion Power OFF=H Signal is applied from the Protector P.C.B., the Power Flip-Flop will be reset directly through D502.

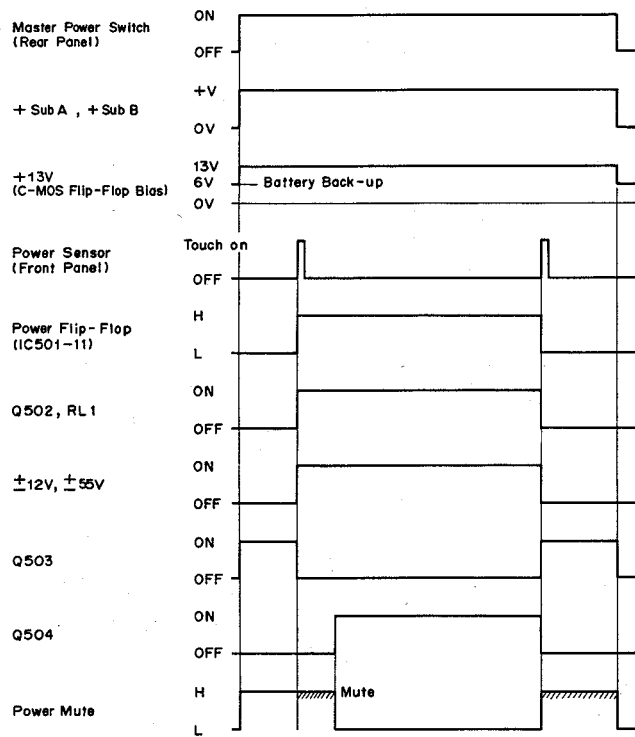

Fig. 2.2.1 Power Mute Timing Chart

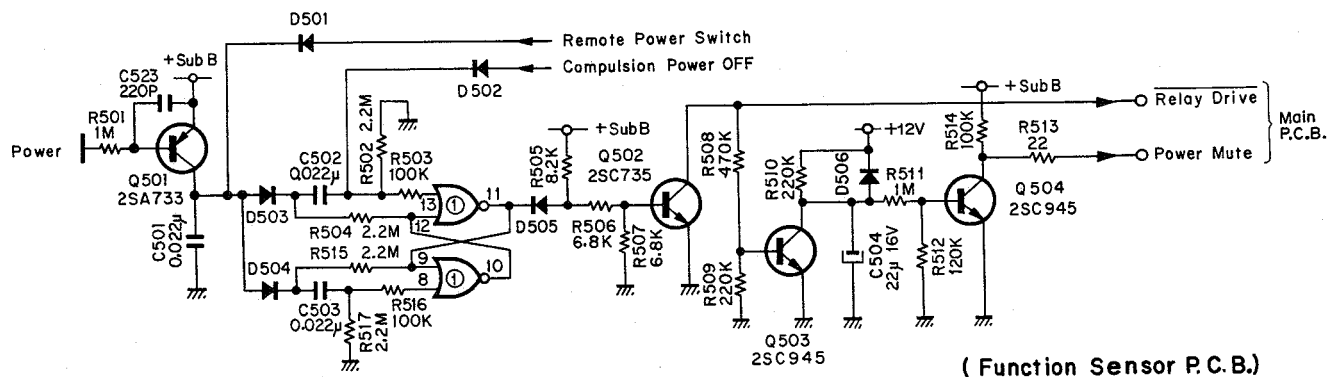

Fig. 2.2.2

2.2.2. Power Lamp and Back-up by Dry Cell Battery
Refer to Fig. 2.2.3, circuit diagram.

Supplies power to the C-MOS Flip-Flop of the Tuning Sensor P.C.B. and Function P.C.B. even while in power OFF condition through the Power Sensor of the Front Panel and maintains the state of each Flip-Flop. Power supply to C-MOS Flip-Flop is backed up by dry cell batteries even if Master Power Switch at the Rear Panel is turned OFF or AC power source is cut off. When the Power Sensor is touch-commanded, the Power Lamp on the Front Panel will be turned ON (When Master Power Switch at the Rear Panel is turned ON). When the voltage of the battery is lower than approx. 4 V, the lamp will commence flickering to activate a battery alarm.

Depending upon the Model for export, the Power Lamp at the Front Panel will illuminate at half of the actual brightness when the Master Power Switch at the Rear Panel is turned ON. The Power Sensor, when touch-commanded, will return the lamp to its original brightness. While in battery alarm condition, the lamp will start flickering both at half of the brightness and original brightness.

(1) Back-up for C-MOS Flip-Flop Power Source by Battery

+Sub A power source generated from the power supply Sub-Transformer provides rated voltage of +13 V through zener diode ZD801 of the Tuning Logic P.C.B. +13 V will be supplied to C-MOS Flip-Flops of the Function Sensor

P.C.B. and Tuning Sensor P.C.B. through D811, during which operation there will be no consumption of battery as D812 is reversely biased. Either when the Power Switch at the Rear Panel is OFF or AC power supply is cut off, battery voltage (approx. 6 V) will be supplied to C-MOS Flip-Flop through D812.

(2) Power Lamp and Battery Alarm

IC506-1, 2, 3 is of an astable multivibrator and oscillates repeating periodical (approx. 1.5 sec) square wave. Q506 compares the battery voltage with the emitter voltage (approx. 4 V) of Q506, wherein if the battery voltage is 4 V or more, D507 will be opened and therefore Q506 will be turned ON. Q505 will, if Q506 is turned ON, maintain its ON-condition regardless of the output of the oscillator IC506. On the other hand, if the battery voltage is below 4 V, D507 will be turned ON via R522, and Q506 will therefore be reversely biased to OFF. As a result, Q505 is controlled by the oscillating output of IC506 to repeat ON/OFF, illuminates the Power Lamp, and activates the battery alarm.

(3) Load Current of C-MOS Flip-Flop

In order to minimize the power consumption while the battery voltage for back-up purpose is being applied to C-MOS Flip-Flop, a diode is provided at the output of the C-MOS Flip-Flop. This diode will prevent load current flow even if the output of Flip-Flop is H (approx. 6 V)

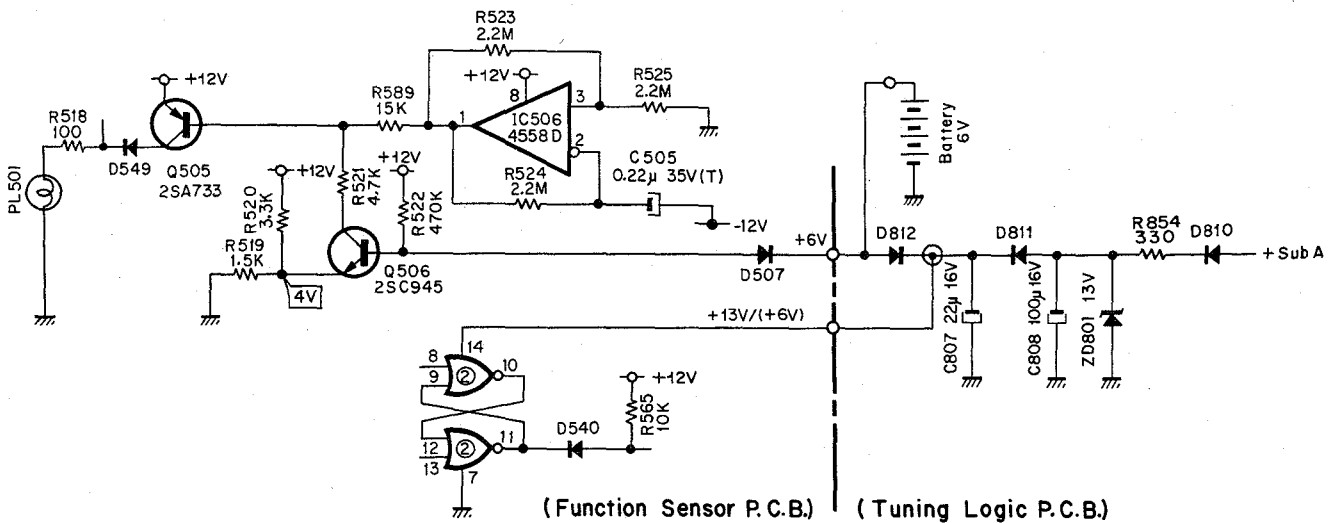

Fig. 2.2.3

2.3. Function Selectors

2.3.1. Function Selectors

Refer to Figs. 9.1 and 9.2, block diagrams.

Each of the Functions (Phono, Aux, Tape 1, Tape 2, FM or Dolby FM) can be changed over to another by turning ON/OFF the Bilateral Semiconductor Switch of the Main P.C.B. by means of the signals of each function control. The function control signals are generated by the Function Sensors (Phono, Aux, Tape 1, Tape 2 and FM) of the Function Sensor P.C.B. and Dolby FM of the Tuning Sensor P.C.B. When the control signals are either at FM, Dolby FM, Phono, or Aux, the Bilateral Switch will be turned to ON when the zener voltage of the zener diode to the Bilateral Switch is exceeded. If the position is either at Tape 1 or Tape 2, the Bilateral Switch will be turned ON when Q108 or Q208 is turned ON. Immediately when each of the functions is selected, mute signals comprising differential signals will be supplied to the Mute Generator, Q309 and Q308, thus mute signals will be generated.

2.3.2. Operation through Remote Controller

Remote Controller RM-730 enables to select each of the functions. This circuit (as shown in Fig. 2.3.1) is of a multiplexer, activating each of the functions through L/R signal which enters the 2nd pin of CN-2. The L/R signal is normally in low level and set to Left. D319, 320, 321 and 322 are therefore turned ON and the input of the 3rd Pin of the CN-2 will be fed to the 5th pin of CN-5.

Similarly, the 4th pin input of the CN-2 will be fed to the 1st pin of CN-6, input of the 5th pin of CN-2 to the 3rd pin of CN-6, and the input of the 6th pin of CN-2 to the 5th pin of CN-6. The power switch command is made individually and is supplied to Function Sensor P.C.B. through the Main P.C.B.

When the 2nd pin of CN-2 shows H, it is set to Right, Q310 is therefore turned ON, and D323, 324, 325 and 326 will be turned ON. Thus each of the functions is activated.

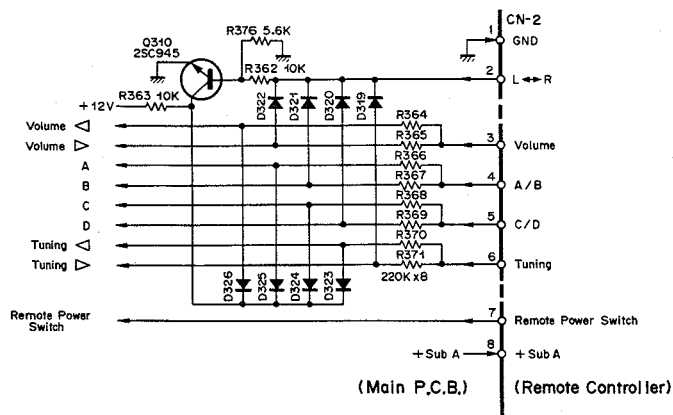

Fig. 2.3.1 Multiplexer Circuit for Remote Control

2.3.3. Tape Monitor

Selection of either Tape 1 or Tape 2 of the Function Sensor P.C.B. will be made by touching thereon. When you desire to select the Tape 1 and touched thereon, Q530 will be turned ON, PL509 illuminates, and Q529 and Q531 will become in cutoff state which will cut off RL301 and RL302 in the Main P.C.B. Thus Tape Monitor 1 will be selected.

When you selected the Tape 2, Q530 in the Function Sensor P.C.B. will become cut off, Q531 to ON, PL510 illuminates, and the 8th pin of CN-16 will become H, and therefore RL302 in the Main P.C.B. will be turned ON. Thus Tape Monitor 2 will be selected.

In case of Source, the activation of Q529 in the Function Sensor P.C.B. will illuminate PL508, Q532 to ON, and 7th pin of CN-16 will become H, when Q530 and Q531 are in cutoff condition. This way, RL302 in the Main P.C.B. will be turned ON to Source. RL302 is in cutoff condition.

2.3.4. Change-over to Tape/Source

When either Source, Tape 1 or Tape 2 of the Tape Monitor Sensor group at the Function Sensor P.C.B. is touched on, each of the Flip-Flops will be set (IC504-3=H, IC505-11=H or IC505-3=H), and Q529, Q530 or Q531 will be turned ON. Thus either Source, Tape 1 or Tape 2 lamp will be lit ON. One of the lamps is always lit.

As to the Source/Tape Signal, Q532 will be turned ON in Source mode to H, and L at either Tape 1 or 2. Comes to Tape 1/Tape 2 Signal, Q533 will be turned ON at Tape 2 mode to H, and L either in Tape 1 or Source. The said signals will be fed to the Main P.C.B., turn ON the relay RL301 at Source/Tape=H (Source Mode), therefore source input (Phono, Aux, Tape 1, Tape 2, or FM) will be fed to the Preamp. Output Terminals.

RL302 will be turned ON at Tape 1/Tape 2=H (Source/Tape=L). RL302 will be turned OFF at Tape 1/Tape 2=L. Therefore the playback input of Tape 2 and that of Tape 1 will be thus obtained at the Preamp. Output Terminals.

2.3.5. Function Sensors

While Source is touched to select Source Mode, if either of Function Sensors, i.e. Phono, Aux, Tape 1, Tape 2 or FM, is touch-commanded, each of the Flip-Flops is set (IC502-11=H, IC502-3=H, IC503-11=H, IC503-3=H or IC504-11=H), and either Q524, Q525, Q526, Q527 or Q528 will be turned ON, and the lamp of either Phono, Aux, Tape 1, Tape 2 or FM will be lit. When a sensor is touch-commanded, the other Flip-Flops will be reset, thus only one lamp will be lit ON. Each of the transistor output of either Phono, Aux, Tape 1 or Tape 2 will be fed to the Main P.C.B. and turn ON the corresponding Bilateral Switch at level H, thus the input of Phono, Aux, Tape 1, or Tape 2 comes out at Recording Output Terminals and Preamp. Output Terminals.

On the other hand, the FM Flip-Flop output IC504-10 (FM Mode) and IC504-11 (FM Mode) will be fed to the Tuning Sensor P.C.B. to be used for controlling purpose. The FM Signal, when combined with the Dolby FM Sensor to be mentioned later, will be induced at the Recording Output and Preamp. Output Terminals to transmit the message of FM broadcast and Dolby FM broadcast.

Mute of function controls:

(1) Mute when Tape 1 or Tape 2 is touch-commanded.

When you selected the Function Sensor Tape 1 or Tape 2, Q108 of the Main P.C.B. will be turned ON by Tape 1=H and therefore Q106 and Q107 will be turned ON, thereby muting the Recording Output Terminals of the Tape 1. Turning ON the Q208 through Tape 2=H will further turn ON Q206 and Q207, thereby muting the Recording Output Terminals of Tape 2.

(2) Prevention of Noise from Function Sensor ON/OFF

In order to prevent generation of noise when changing Function Sensors, muting is provided for a certain period of time simultaneously when any of the Function Sensors (Phono, Aux, Tape 1, Tape 2, FM, or Dolby FM) is changed to another.

When the signal at H Level of either Phono, Aux, Tape 1, Tape 2, FM or FM Dolby is transmitted to the Main P.C.B., it will then enter each of the corresponding C333, C334, C335 via Q108, C336 via Q208, C331, or C332, and differential pulse will be given to Q309 of the Mute Generator. Thus Q309 and Q308 will be turned ON. Then Q106, Q107, Q206 and Q207 will be turned ON to mute the Recording Output Terminals, Q109 and Q209 will be turned ON to mute the input of the Output Buffer Amp. (IC303-(1/2) and (2/2)), and then Q102 and Q202 of the Tone Control P.C.B. will be turned ON to mute the Preamp. Output Terminals.

(3) Mute when more than 2 Function Sensor Lamps are lit.

When more than 2 Function Sensors are touch-commanded to turn ON, the common emitter voltage will become approximately twice as much as an ordinary one lamp. This voltage is divided by R377 and R350 in the Main P.C.B. but exceeds the turn-ON voltage of Q309, therefore Q309 is turned ON and Mute is activated.

(4) Mute when Function Sensor Lamps are blown.

Function Lamp Signal comes from the common-emitter of the corresponding Function Lamp Driving Transistors Q524, Q525, Q526, Q527 and Q528. In an ordinary condition, as one of the lamps is lit without fail, the Function Lamp Signal is of plus voltage.

When a lamp is now blown and its pertinent function is selected, Function Lamp Signal will become 0 V and cuts off Q306 of the Main P.C.B. Accordingly +12 V will be

given to Q309 of the Mute Generator through R352 and D311 to activate muting.

The following operation is identical to item (2) as above.

2.3.6. Stereo/Mono Sensor

When Stereo/Mono Sensor of the Tuning Sensor P.C.B. is touch-commanded to set to Stereo, the Flip-Flop output will become IC601-10=H, and IC601-11=L. At the same time, Mono will be released by Mono/Stereo=L Signal fed to the Main P.C.B. The Stereo Lamp connected IC601-10 will be lit as follows:

(1) When Function Sensor FM is not selected (FM Mode=H), i.e. either of Phono, Aux, Tape 1, or Tape 2 is selected, D604 is cut off. Accordingly Q602 is turned ON by IC601-10=H and Stereo Lamp will then be lit.

(2) When FM is selected by the Function Sensor FM (FM Mode=L), Q602 will be cut off and Stereo Lamp will go out as the D604 will be turned ON and connected to GND.

On the other hand, when the output signal from the MPX IC301-9 of the Main P.C.B. connected to the collector of Q602 is set to Stereo Indicator=L, i.e. when receiving an FM stereo broadcasting, Stereo Lamp will be lit.

When Stereo/Mono Sensor is touch-commanded to set to Mono, the output of its Flip-Flop will become IC601-10=L and IC601-11=H. IC601-11=H will activate to become Mono/Stereo=H and enters MPX IC301-16 through D304 of the Main P.C.B. and then set MPX to Mono.

This signal will also turn ON Q311 of the Main P.C.B. to set it to Mono=L and further turns ON RL301 of the Tone Control P.C.B. Accordingly, both inputs of the Balance Control Volume will be shorted by the contact of RL301 and mono output will be obtained at the Preamp. Output Terminals.

2.3.7. Dolby FM, Hi-Blend and FM Mute Sensor

When either of the Dolby FM, Hi-Blend, or FM Mute of the Tuning Sensor P.C.B. is touch-commanded, the corresponding Flip-Flop will be set to turning ON each of the lamps. In this juncture, each of the output signals will become H if FM Mode=H (FM mode is an output of FM Flip-Flop of the Function Sensor P.C.B.).

If FM Mode=L, condition of the lamp lighting stays the same, but each of the output signals will become L and will be inhibited.

(1) Dolby FM Sensor

When Dolby FM Sensor is touch-commanded, the Dolby FM Flip-Flop will be set to IC601-3=L, as a result of which Q604 will be turned ON and the Dolby FM Lamp will be lit, when the mode will become Dolby FM=H and FM=L under the condition of FM Mode=H (D609 and D611 are cut off).

Through Dolby FM=H, Bilateral Switch IC305-6, 8, 9 and

-10, 11, 12 of the Main P.C.B. will be turned ON, and Dolby FM broadcasts will therefore be obtained at the Recording Output and Preamp. Output Terminals.

When the Dolby FM Sensor is again touch-commanded to reset the Dolby FM Flip-Flop, it will become IC601-3=H, turning OFF Q604 and the Dolby FM Lamp will go out. At this time, Dolby FM=L and FM=H will turn ON the Bilateral Switch IC304-1, 2, 13 and -3, 4, 5, of the Main P.C.B. as a result of which FM broadcasts will be obtained at the Recording Output and Preamp. Output Terminals.

(2) Hi-Blend Sensor

Blends L and R channels of the FM Broadcasts at high frequency. When the Hi-Blend Sensor is touch-commanded, the Hi-Blend Flip-Flop will be set to IC602-10=L, as a result of which Q606 will be turned ON and the Hi-Blend Lamp will be lit. When the Hi-Blend=H, under the condition of FM Mode=H (D615 is cut off), D307 of the Main P.C.B. is cut off and Q303 is turned ON. As a result of which L and R channels are connected through C320, C321 and R329, both of the R and L channels will be blended at high frequency. When Hi-Blend Sensor is again touch-commanded to reset the Flip-Flop, Hi-Blend will become L, D307 of the Main P.C.B. will turn ON and Q303 cuts off, as a result of which the mode will return to normal.

(3) FM Mute Sensor

When the FM Mute Sensor is touch-commanded, the FM Mute Flip-Flop will be set, IC602-4 will become L, Q608 will turn ON, and the FM Mute Lamp will light ON. If the Motor is driving while tuning (except for manual tuning through Preset Control), Compulsion Mute=L from the Tuning Logic P.C.B. will be fed to the base of Q608 of the Tuning Sensor P.C.B. Accordingly, the FM Mute Lamp will also light ON. At this time, FM Mute will become H through Q608 ON under the condition of FM Mode=H (D619 is cut off), please refer to item 2.4.7. FM Mute as to its details.

2.3.8. Audio Mute Sensor

When the Audio Mute Sensor of the Function Sensor P.C.B. is touch-commanded, the Audio Mute Flip-Flop will be set to become IC501-4=L, Q514 will turn ON, the Audio Mute Lamp will light ON, Q515 will turn OFF, and the Audio Mute Signal will become open from +12V. This signal enters the Tone Control P.C.B. via the Main P.C.B. and will cut off Q101 and Q201. The shorted R105 and R205 through collector emitter of Q101 and Q201 will therefore enter to the circuit in series, the gain of the Tone Control Buffer Amp. IC301-(1/2) and (2/2) will lower by approx. 14 dB.

2.3.9. Volume Motor Control

Refer to Fig. 2.3.2, circuit diagram.

If either Right or Left of the Volume Control Sensor is kept being touch-commanded, the volume motor will continue its rotation and the volume level will become either increased or decreased. When you touch-command Right, Left or the Sensor located between therewith simultaneously, the driving speed of the Motor will become slower.

When the Sensor Left is touch-commanded, Q507 will turn ON (but Q509 and Q508 will cut off). Accordingly, IC506-7 will become approx. 10 V, as a result of which Q510 will turn ON, approx. 9.5 V will be fed to the Volume Motor via the Tuning Logic P.C.B.

When the Sensor Right is touch-commanded, Q509 will turn ON (Q507 and Q508 will cut off), and IC506-7 will become approx. -10 V, as a result of which Q511 will turn ON, and approx. -9.5 V will be applied to the Volume Motor, and the Motor will start rotating the other way round.

In addition to the touch-command on the Sensor Right or Left, if you touch-command the middle Sensor, Q508 will turn ON, Q512 will turn ON, the resistor R529 will be connected to GND through R531 and Q512. Accordingly, the output voltage from IC506-7 will decrease, and the voltage to be fed to the Volume Motor will become decreased, and therefore the speed of the Motor rotation will become slow.

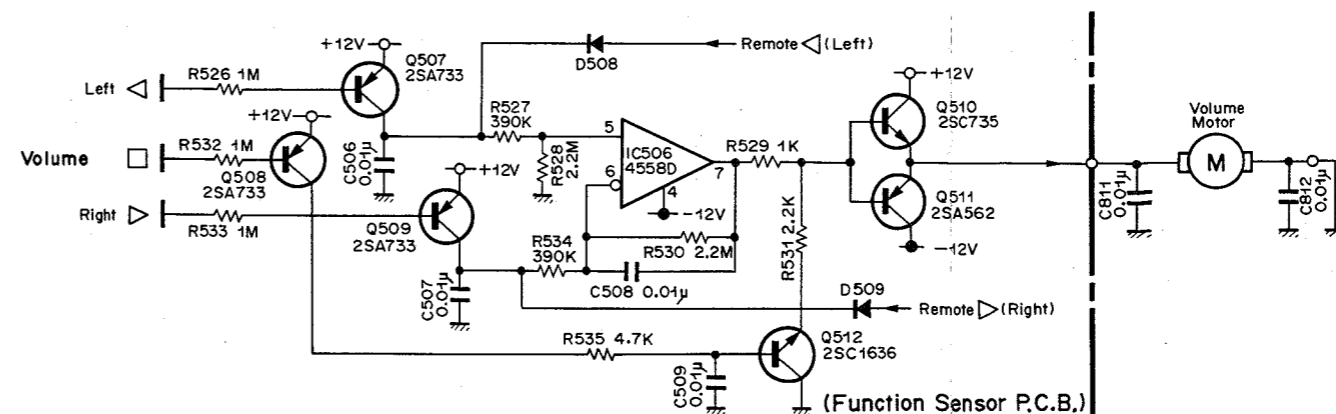

Fig. 2.3.2 Volume Motor Control Circuit

2.4. Tuner Section

2.4.1. FM MPX Stereo Broadcasting Operation

As is generally known, the amplitude of the carrier wave is modulated in AM broadcasting whereas the carrier frequency is modulated in FM broadcasting. Fig. 2.4.1 illustrates these conditions.

FM transmitters and receivers, although considerably more complicated than those for AM broadcasting, permit radio reception with very high fidelity and any difference in technical skill will be noticeably manifested in the performance of the equipment. Compared to AM broadcasting, FM broadcasting has many advantages, such as better frequency response, higher S/N ratio, less interference, less distortion, etc. However, its greatest advantage is the capability for compatible stereo broadcasting. This is achieved by employing a composite signal, as shown in "4" of Fig. 2.4.2, instead of the audio signal shown in Fig. 2.4.1.

Since the composite signals transmitted in ordinary broadcasting have an extremely complex waveform, it is hard to recognize them, even when observed with an oscilloscope. Figure 2.4.2 illustrates an L channel signal of 1900 Hz with no R channel signal.

As shown in "1" of Fig. 2.4.2, this is a stereo signal modulated so as to swing at 38 kHz between the L channel signal and R channel signal.

Therefore, this signal can be separated into L ch/R ch, by a synchronizing signal with the 38 kHz of the stereo signal and a circuit which is conducting at the positive peak and negative peak of this synchronizing signals; the L ch/R ch signals will come out separately.

But, as is shown by the signal waveform "1" in Fig. 2.4.2, since the phase at 38 kHz is reversed between the positive and negative half-cycles of the L ch signal, even with the separation described above, it is not possible to distinguish L ch from R ch.

Under these conditions, it is possible that the L ch/R ch is reversed each time the power switch is turned ON/OFF. Here lies the importance of the pilot signal. That is, when making the 38 kHz signal ("3" in Fig. 2.4.2) by doubling the 19 kHz pilot signal, if the positive and negative peaks of the 19 kHz wave are synchronized with a negative peak at the 38 kHz, L channel can be taken out at the positive peak of the 38 kHz signal and the R channel at the negative peak. Thus, MPX stereo signals are broadcast in a waveform such as composite signal "4", obtained by combining the pilot signal "2" with the stereo signal "1" in Fig. 2.4.2.

In order to divide the FM signal into the left and right channels, the MPX stage of an FM tuner must synchronize the multiplex signal with the 19 kHz pilot signal. If this synchronization is not properly performed, stereo separation will be poor.

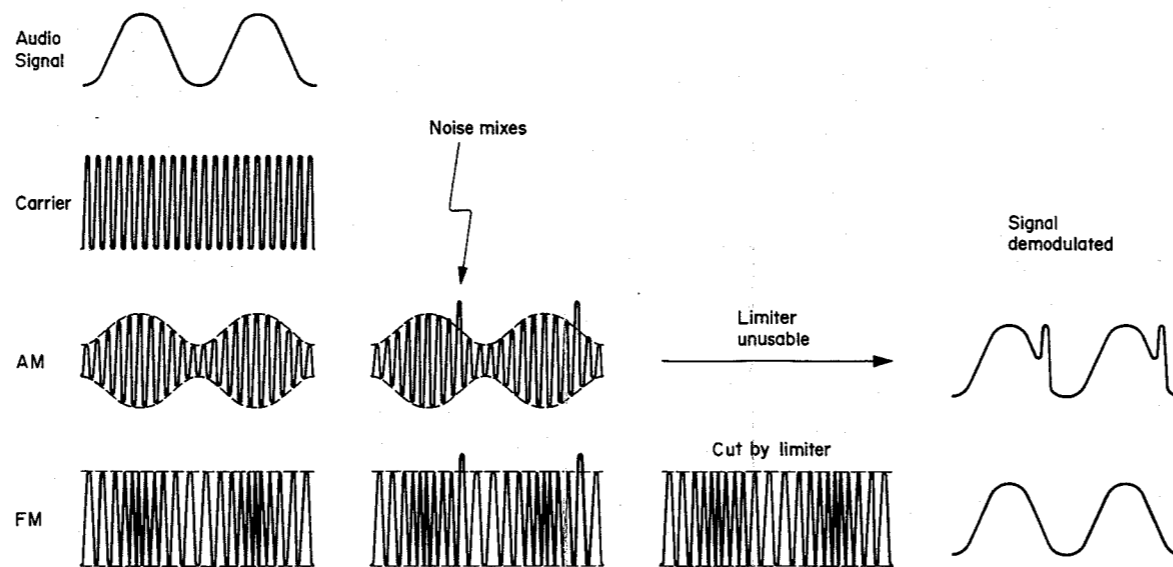

Fig. 2.4.1 AM and FM

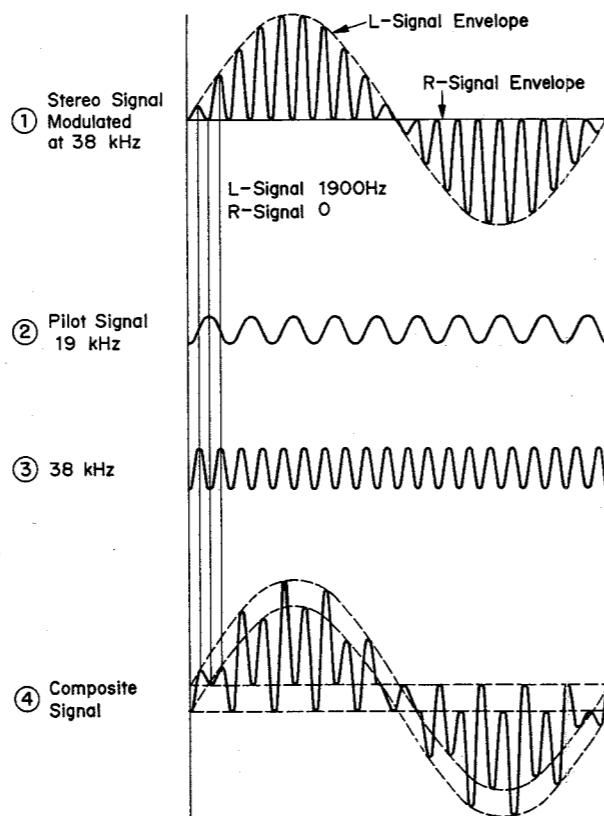

Fig. 2.4.2 MPX Stereo Signal

2.4.2. Operation of Tuner Section

Fig. 2.4.3 shows a block diagram of the N-730 tuner section.

The input from an antenna first enters the Attenuator Switch which can select the input sensitivity either at 0 dB or -20 dB. Selection of -20 dB allows appropriate receiving of the broadcasting station at large field strength.

In the following explanation, Attenuator Switch is selected to 0 dB. The RF signal which enters the radio frequency unit (front-end) through Attenuator Switch, is amplified in a tuning circuit, and mixed with a local oscillator frequency, and an intermediate frequency (IF 10.7 MHz) is produced. Since the radio frequency is high and it is impossible to obtain stable amplification and sufficient separation, it is converted to an easy-to-handle 10.7 MHz. Conversion of IF is made to improve these characteristics.

Frequency conversion makes use of the fact that when two different frequencies are mixed and detected, a frequency component equal to the difference between the two frequencies is generated.

Since radio frequencies vary according to the choice of the station, the tuning circuit must be adjustable. However, the use of an intermediate frequency fixed at 10.7 MHz makes it possible to achieve optimum tuning characteristics with a multi-stage tuning circuit (3-stages in the N-730) and sharp separation with a ceramic filter.

Also, the function of a limiter to remove extraneous noise, as usual in an intermediate frequency unit, requires a sufficiently high-degree of amplification (130 dB or more in the N-730) to improve limiter characteristics. For this purpose and to prevent instability due to output feedback to the input side, an adequate shield must be provided and the component parts must be carefully arranged.

The time required for a signal applied to the input of an intermediate frequency unit to emerge from the output generally varies according to frequency.

In ordinary broadcasting, since the frequency varies in a range of $10.7 \text{ MHz} \pm 75 \text{ kHz}$, a frequency with a shorter transit time catches up with the preceding signal before emerging as output. This will result in a high frequency. Also, an interval will be opened between a slow signal and the preceding signal which produces a lower frequency. This kind of variation in the transit time occurs mainly in the tuning circuit, resulting in increased distortion.

This is called group delay characteristic and of the important features of an intermediate frequency unit.

In the N-730, superior selectivity and group delay characteristics have been realized by employing 4-element Ceramic Filter, SAW (surface acoustic wave) Filter (refer to item 2.1.6), IF Amp. using an IC702 HA11211 and Quadrature Detector (refer to item 2.1.7).

The composite signal is taken out by demodulating the FM signal with a Quadrature Detector, IC702 HA11211, in the intermediate frequency unit.

Linearity of the discriminator is very important, and must be regulated with adequate care since poor linearity will result in increasing distortion and poor channel separation.

Good Quadrature Detector characteristics are shown in Fig. 2.4.4 by the solid line, where the output voltage varies in a straight line over the ± 100 kHz range and voltage is 5.6 V DC at the center frequency. If, as shown by the dotted line, there is asymmetry above and below, the voltage is not 5.6 V DC at the center frequency, and the degree of distortion will increase.

The discriminator of the N-730 has a broad linear zone (± 200 kHz or more). As the Self-Locked Tuning of the N-730 will operate approximately 7 seconds after the tuning. FM broadcast-receiving can be performed under the distortion free condition at all times.

The discriminator output is applied to the PLL (phase-locked loop) IC μ PC1161C in the MPX unit.

The 38 kHz signal which is synchronous with the 19 kHz involved in the composite signal is produced in MPX unit. This leads to separate the L channel and R channel signals (refer to Fig. 2.4.2).

Therefore, in order to achieve good channel separation, the high end and low end of the 38 kHz waveform must be symmetrical and the phase must be precisely aligned. In the N-730, good channel separation has been realized by means of a stabilized synchronizing signal obtained by a PLL IC.

With this, even if an SCA (Subsidiary Communication Authorization) signal is present, no beat interference can occur.

To obtain a good S/N ratio, pre-emphasis is made on the transmitter side and de-emphasis is made on the receiver side.

The time constant of $75 \mu s$ is mainly employed by the U.S.A. and Canada, and $50 \mu s$ in Europe and other countries including Japan. In Dolby FM broadcasting, the time constant is $25 \mu s$. Consequently, in the N-730, de-emphasis is made in the MPX unit at $25 \mu s$ and a circuit is provided after the Dolby NR circuit to change the time constant to $75 \mu s$ or $50 \mu s$.

When Dolby FM mode is selected, time constant becomes $25 \mu s$ nullifying the $50 \mu s$ and $75 \mu s$ time constant.

In FM mode, time constant of $50 \mu s$ and $75 \mu s$ becomes possible and the changeover of time constant ($50 \mu s/75 \mu s$) is made by Emphasis Switch on the Main P.C.B.

Note: When Dolby NR circuit is not incorporated, no output is available if Dolby NR mode is selected.

The Dolby NR circuit, being highly sensitive to high frequencies, will malfunction when there is a carrier leak from the MPX unit.

Although the 19 kHz pilot signal is especially difficult to remove because of its proximity to the audio signal, the N-730 uses a specially-designed low-pass filter to achieve an attenuation characteristic of 40 dB or more for the 19 kHz signal, while keeping flat frequency response up to 15 kHz.

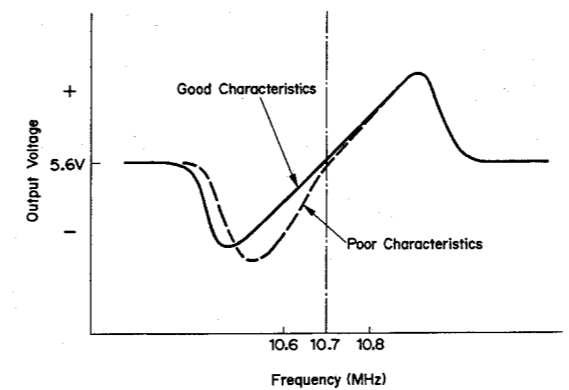

Fig. 2.4.4 Discriminator Characteristics (S-Curve)

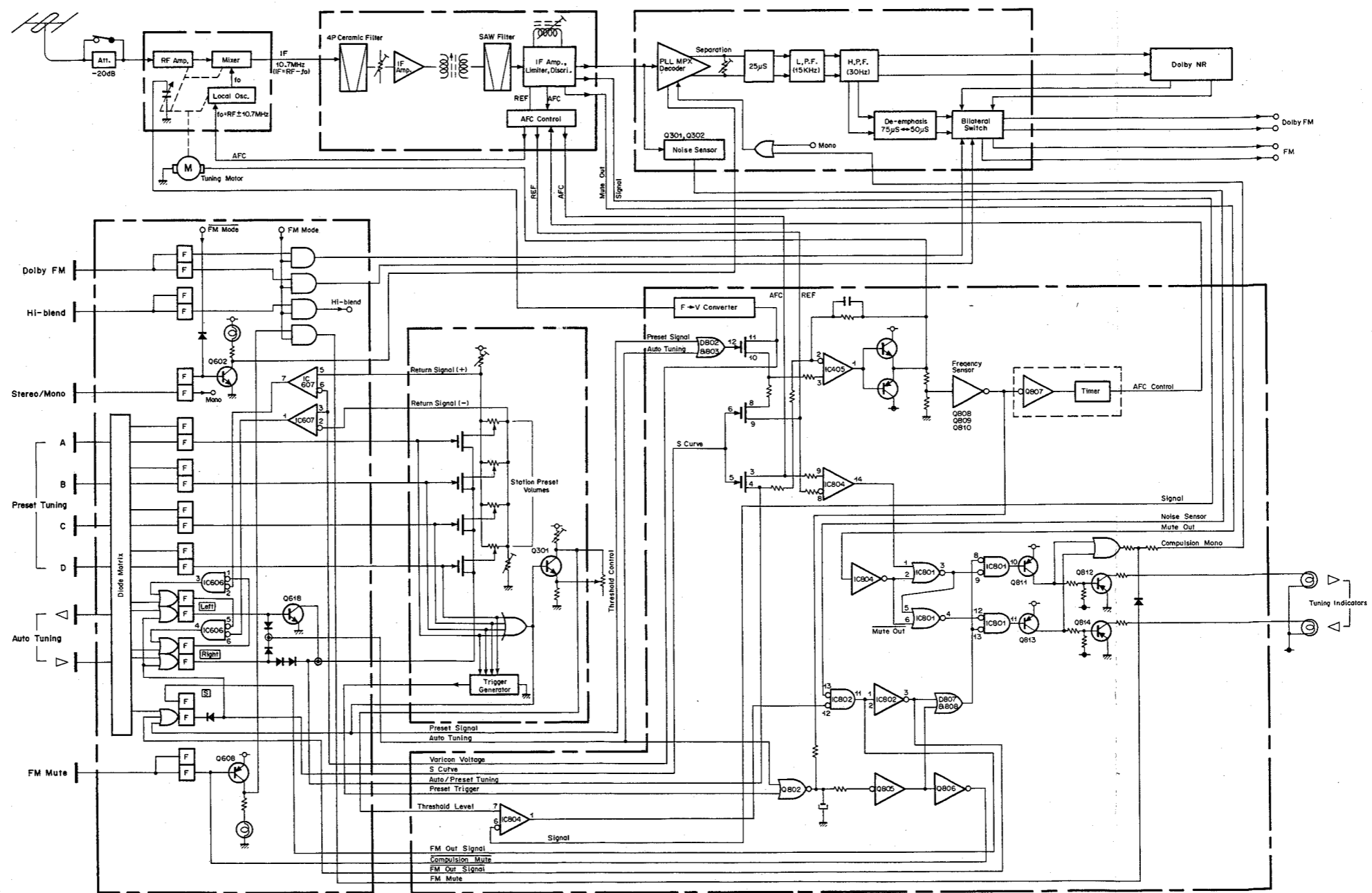

Fig. 2.4.3 FM Tuner System Diagram

2.4.3. Tuning System

(1) Varicon Voltage

Refer to Figs. 2.4.5 and 2.4.6, circuit diagram and timing chart.

Generates the DC voltage (Varicon Voltage) corresponding to the capacity of varicon by means of an AM varicon of the Front-end. The DC voltage is in an inverse proportion to the varicon capacity, wherein when capacity is increased, voltage will become decreased. As the varicon capacity corresponds to the tuning frequency, the said Varicon Voltage will become to correspond to the tuning frequency.

The variable voltage range of the preset tuning and minimum, and maximum range in which the auto-return is activated is also established within this Varicon Voltage range.

IC804-(1/4) of the Tuning Logic P.C.B. forms an astable multivibrator and oscillates square wave of approx. 5 kHz. This oscillation output will enter variable integral circuit (becomes variable according to variation of varicon capacity). The integrated signals will enter the plus Peak Hold circuit consisting of IC805-(2/2) and will be converted to DC voltage in inverse proportion to the varicon capacity.

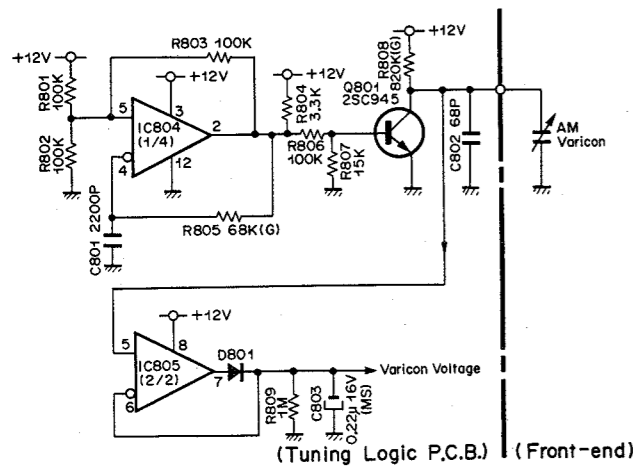

Fig. 2.4.5 Varicon Voltage Generating Circuit

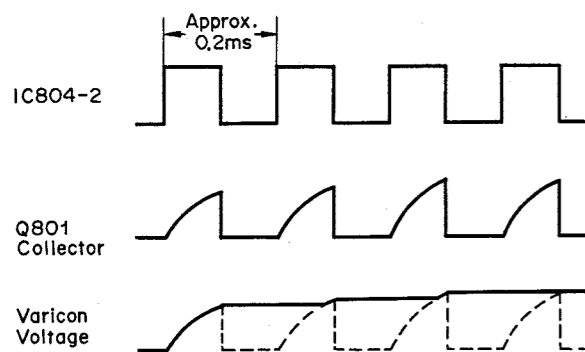

Fig. 2.4.6 Timing Chart

(2) Motor Drive Circuit and Frequency Sensor (Motor Drive Detection Circuit)

Refer to Fig. 2.4.7, circuit diagram.

The Tuning Motor of the N-730 drives Front-end. The Tuning Motor drive circuit consists of IC805-(1/2), Q803, Q804, etc.

IC805-(1/2) forms a comparison circuit, and by the Bilateral Switch connected thereto will make comparison between the Varicon Voltage and Auto/Preset Tuning, or between AFC and Ref. voltage, and drives the Tuning Motor through the driver of Q803 or Q804. If the both inputs of IC805-(1/2) become identical, i.e. when the difference of the both inputs becomes zero, the output of the IC805-(1/2) will become 0 V, the Tuning Motor will become in stop mode. The Frequency Sensor circuit consists of Q808, Q809 and Q810, and the collector of Q808 and Q809 will generate output of 12 V in stop mode, otherwise 0 V while the Tuning Motor is driving.

(a) Preset Tuning

When Station Memory Sensor A, B, C, or D is touch-commanded, the Preset Signal will become H, and the Bilateral Switch IC803-10, 11, 12 will turn ON through D802, as a result of which Varicon Voltage will be obtained at IC805-3(1/2).

On the other hand, as the set voltage (approx. 2-9 V) is given to the Auto/Preset Tuning Signal (IC805-2(1/2)) through each of the Station Preset Controls, the Tuning Motor will be driven until the difference of the both inputs of IC805-(1/2) becomes zero. When the difference becomes zero, i.e. when the Varicon Voltage becomes equal to the preset voltage through Preset Control, the motor will stop its rotation.

From this condition, when you turn the Preset Control manually, both of the Amp. inputs will become imbalance as the voltage of the Auto/Preset Tuning (IC805-2(1/2)) changes. Accordingly, the Motor rotates until the difference of the both Amp. inputs becomes nil. Thus the setting to the new point will become possible.

(b) Auto-Tuning

When the Tuning Sensor Left is touch-commanded, the Auto Left Flip-Flop of the Tuning Sensor P.C.B. will become set, the Auto-Tuning Signal will become H, and the Bilateral Switch IC803-10, 11, 12 will turn ON through D803. Thus Varicon Voltage will be obtained at IC805-3(1/2). On the other hand, Auto/Preset Tuning Signal=0 V will be fed to IC805-2(1/2).

As this 0 V is definitely lower than the Varicon Voltage (approx. 2-9 V), IC805-1(1/2) will become approx. +12 V which will turn ON Q803, approx. +12 V will be given to the Tuning Motor, and the Motor will begin to rotate so that the Tuning Pointer will move to the left direction on the scale. When the Tuning Sensor Right is touch-commanded, the Auto-Tuning Signal will become H and the Auto/Preset Tuning Signal will become approx.

11 V being the same as Left. As this 11 V level is absolutely higher than the Varicon Voltage (2-9 V), IC805-1(1/2) will become approx. -12 V thereby turning ON Q804 and approx. -12 V will be fed to the Tuning Motor, as a result of which the Motor will start running to the direction so that the Tuning Pointer will move to right hand side on the scale.

While Auto Tuning, when a station is detected in accordance with Station Detecting Circuit as per (4), the following will be activated:

When a station is detected, the signal, FM Signal=H, will set the S-curve Flip-Flop of the Tuning Sensor P.C.B. and will reset the Auto Left or Right Flip-Flop.

The above will make S-curve Signal to H, thus Bilateral Switch IC803-3, 4, 5 and IC803-6, 8, 9 will be turned ON, and AFC and Ref. Signals will be given to the input of IC805 (when the Auto/Preset Tuning Signal to the IC805 input are in the open state, and IC803-10, 11, 12 is closed). When the Motor started running and AFC becomes equal to Ref. i.e. the difference between the inputs of the IC805 becomes nil and tuning is finished, the Motor will stop its rotation.

(c) Frequency Sensor (Detector while Motor Drive)

While the Tuning Motor is driving, the Frequency Sensor output (Q808 and Q809 collector voltage) will become 0 V as Q809 will be turned ON when +12 V is given to the Motor, or Q810 and Q808 will be turned ON when -12 V is given to the Motor. When the Motor is in stop mode, i.e. no voltage is being given to the Motor, Q808, Q809 and Q810 will be turned OFF, and the output of the Frequency Sensor will become +12 V.

(d) AFC Control Signal

The collectors of Q808 and Q809 are at 0 V while motor drive, Q807 will be turned ON, then C805 is charged to obtain +12 V AFC Cont. Signal. AFC Cont.=+12 V signal enters the IF Unit and turns ON the FET Q701, as a result of which the Reference voltage (5.6 V) of IF Unit will be fed to Front-end Unit AFC terminal, thus AFC will not activate while the Motor is driving.

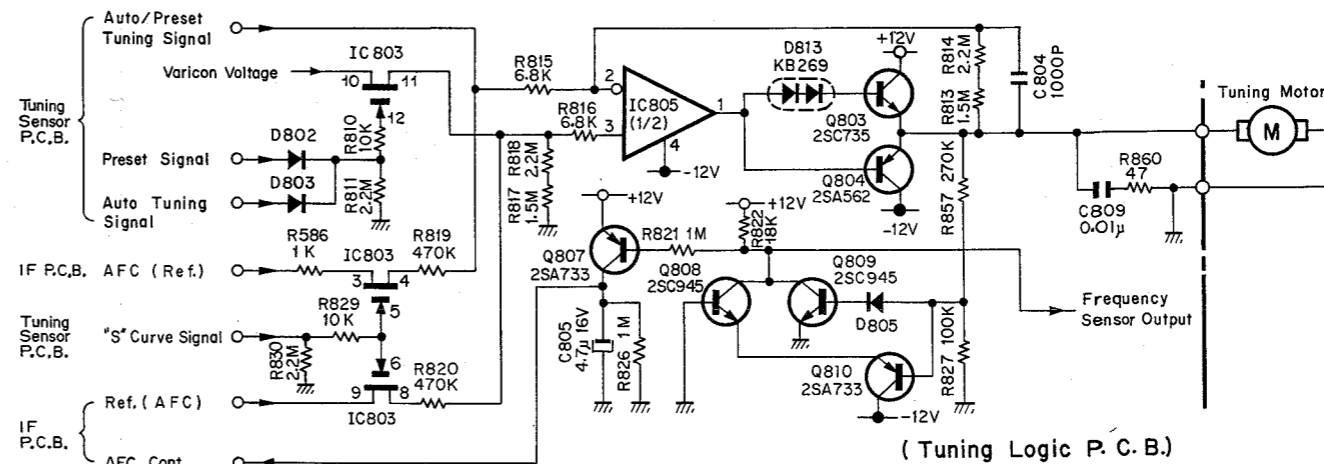

Fig. 2.4.7 Motor Drive Circuit

(3) Preset Tuning

Refer to Fig. 2.4.8, circuit diagram. Fig. 2.4.9. shows the range of preset variable voltage while tuning, and the voltage of Plus Return Signal and Minus Return Signal for the Auto-Return while auto-tuning. Touch-command on either A, B, C, or D of the Station Memory Sensors will automatically select the preset station through the corresponding A, B, C, or D Station Preset Control, when the Auto-Tuning Flip-Flop is reset. If you touch-commanded the Station Memory Sensor A, the Station A Flip-Flop (IC603-8, 9, 10, and -11, 12, 13) will be set, IC603-10 will become L and IC603-11 becomes H, thus D631 will become open. As a result, Q610 will be turned ON, Station A Lamp (PL605) will be turned ON and then A Signal will become H. The Bilateral Switch IC301-3, 4, 5 of the Preset P.C.B. will be turned ON at A Signal=H, and the voltage preset by VR304 will be given to IC301-3 (Auto/Preset Tuning).

The Preset Signal at A Signal=H will become H through D301 and reset S-curve Flip-Flop. Preset Trigger pulse will be induced at A Signal=H. These signals will then enter the Tuning Logic P.C.B.

Auto/Preset Tuning Signal (preset A level) will be fed to IC805-2 and Varicon Voltage will be given to IC805-3 as

the Bilateral Switch IC803-10, 11, 12 will be turned ON at Preset Signal=H through D802.

The Tuning Motor will drive either to right or left direction depending upon the both input levels of Amp. IC805, changes Varicon Voltage, and then stops when the Varicon Voltage becomes equal to the preset level. Above state will remain until the other Station Memory Sensors or Tuning Sensors are touch-commanded. When the Preset Control is manually turned, the balance between the Amp. inputs will become unequal as the Auto/Preset Tuning voltage (IC805-2(1/2)) is changed. The Motor will therefore drive along the rotation of the Control so that the difference between the said inputs will become 0.

The Threshold Level will, regardless of the position of the Threshold Volume, indicate approx. 3 V, as Q301 of the Preset P.C.B. turns ON while preset tuning and thus the Threshold Volume will be shorted by Q301 (level will be decided by the adjustment of VR302). As Q301 will be cut off while auto tuning, the threshold level set by the Threshold Volume will be obtained.

The Preset Trigger Pulse generated at the Preset P.C.B. will turn ON Q802 to be in pulse-state through D804 and discharges C806.

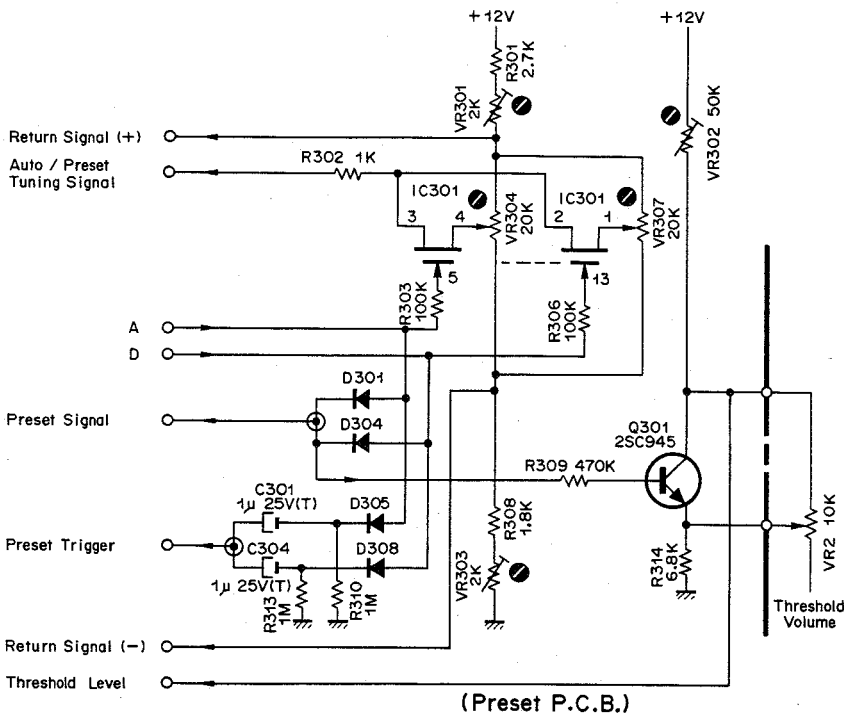

Fig. 2.4.8 Preset Tuning Circuit

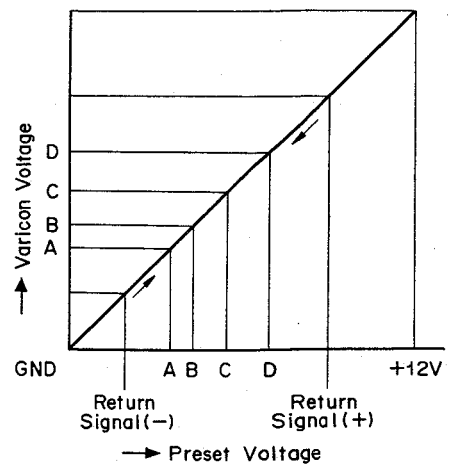

Fig. 2.4.9 Preset Voltage Range

(4) Station Detecting Circuit (FM Out Signal)

Refer to Fig. 2.4.10, circuit diagram.

FM Out Signal will become H while a station is detected by tuning, and on the other hand, $\overline{\text{FM Out Signal}}$ is a reversal of the said FM Out Signal and will become H while no station is detected. IC804-1(4/4) will become L, when the DC voltage "Signal" which is output of the FM demodulator and corresponding to the strength of radio field from FM broadcasting stations exceeded the pre-determined threshold level (this threshold level is set by means of the Threshold Control at the Front Panel while

auto-tuning, and the threshold volume while preset tuning will be shorted through Q301 ON of the Preset P.C.B., and will be firmly set to the level (approx. 3 V) being the same when the threshold control is set to its minimum position). On the other hand, while a station is already selected, Noise Sensor will become L as the Noise Sensor circuit consisting of Q301 and Q302 of the Main P.C.B. cannot detect the inter-station noise.

When the foregoing 2 conditions, i.e. both of IC802-12 and 13 are L, IC802-11 which is in other words FM Out Signal will become H, thus a station is now detected.

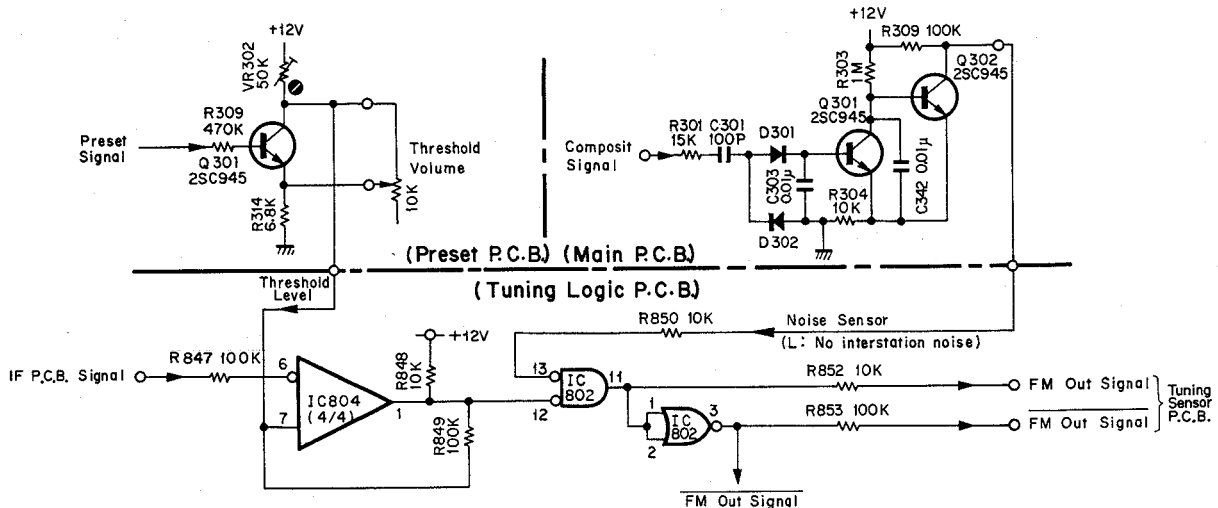

Fig. 2.4.10 Station Detecting Circuit

(5) Auto-Tuning

Refer to Fig. 2.4.11, circuit diagram.

(a) Auto-Tuning

General flow will be as follows:

Tuning Sensor Left/Right touch-commanded momentarily – Auto Left/Right Flip-Flop (IC605-8, 9, 10, 11, 12, 13/IC605-1, 2, 3, 4, 5, 6) is set – Tuning Motor starts driving (until a station is detected) – station detected (FM Out Signal becomes H) – S-curve Flip-Flop is set and Auto Left/Right Flip-Flop is reset – Tuning Motor starts driving (until tuning is completed i.e. voltage AFC becomes equal to Ref.) – Auto-tuning completed (Tuning Motor stops.)

If the Tuning Sensor Right or Left is kept being touch-commanded, auto tuning will continue even a station is detected, as S-curve Flip-Flop is not set. Details along with the general flow would be as follows:

1) Tuning Sensor touched-commanded momentarily

When the Tuning Sensor Left or Right is touch-commanded, the station Flip-Flops A through D will be reset and the Auto Left or Right Flip-Flop will also be set.

The Auto Right Flip-Flop will be reset when the Tuning Sensor Left is touch-commanded, and Left Flip-Flop will be reset when the Sensor Right is touch-commanded.

When the Auto-Left Flip-Flop is set, Q618 will turn ON, as a result of which, 0 V will be fed to the Auto/Preset Tuning Signal, but approx. 11 V will be fed through D669 and D668 when Right Flip-Flop is touch-commanded. On the other hand, Auto-Tuning Signal becomes H, through D658 or D666 when either of Flip-Flops is turned ON. These signals will be sent to the Tuning Logic P.C.B. where the Auto/Preset Tuning Signal (either 0 V or 11 V) will be fed to the differential Amp. IC805-2 of the Motor Drive Circuit. On the other hand, the Auto-Tuning Signal=H turns ON the Bilateral Switch IC803-10, 11, 12 through D803 thus Varicon Voltage is applied to IC805-3. As Varicon Voltage is approx. 2 – 9 V, IC805-1 will become approx. +12V when IC805-2 is 0 V (Left Flip-Flop is set), thus Q803 will turn ON and an approx. +12V will be applied to the Tuning Motor, when the Motor starts driving and the Tuning Pointer moves to the left-hand side on the scale. When IC805-2 is 11 V (Right Flip-Flop is set), IC805-1 will become approx. -12 V, thus Q804 will turn ON, approx. -12 V will be given to the Tuning Motor, and the Motor will rotate to move the Tuning Pointer to the right-hand side.

2) Station detected

While the above Motor is driving, when a station is detected as per (4) Station Detecting Circuit, FM

Out Signal will become H. This signal will enter the Tuning Sensor P.C.B. through the Tning Logic P.C.B. where it is differentiated by C619 (pulse is made at the rising of signal) resulting in setting the S-curve Flip-Flop (IC606-8, 9, 10, 11, 12, 13). Once the S-curve Flip-Flop is set, the Auto-Left and Auto-Right Flip-Flops will be reset by IC606-11=H. As the Auto/Preset Tuning Signal becomes open and Auto-Tuning Signal becomes 0 V, the Bilateral Switch (IC803-10, 11, 12) of the Tuning Logic P.C.B. will turn OFF, therefore there would be no input to IC805-(1/2), but as S-curve Flip-Flop will be set, and becomes S-curve Signal=H, the Bilateral Switch IC803-3, 4, 5 and -6, 8, 9 will turn ON, as a result of which AFC and Ref. will be newly input to IC805-(1/2).

In case of AFC=Ref. i.e. tuning is made, the Tuning Motor will stop its rotation, thus auto-tuning is now completed. Q815 to the FM Out Signal will be turned ON in the form of pulse through differential circuit (C810) when S-curve Signal is changed to H. This is intended to securely obtain AFC=Ref. by inhibiting FM Out signal for a certain period of time after S-curve is changed to H (this helps minimize errors in auto-tuning the particularly weak radio stations). S-curve Flip-Flop of the Tuning Sensor P.C.B. will be reset and returned to its original state in case of the following:

- a) Through D671 or D672 when either of the Tuning Sensor Left or Right is touch-commanded
- b) Though D673, when Station A, B, C, or D is set and Preset Signal becomes H

c) Through D670, when no station is detected and FM Out Signal becomes H (this is intended to prevent activation of the Tuning Motor because of a slight left-over voltage between AFC and Ref. even after completion of the broadcasts at night).

3) Tuning-Sensor touched-commanded continuously
When the Tuning Sensor Left or Right is kept being touch-commanded, its activation would be as follows:
When Auto-Tuning detected a station, FM Out Signal becomes H and fed to S-curve Flip-Flop of the Tuning Sensor P.C.B. But if the Sensor is left being touch-commanded, the Flip-Flop is kept reset through D671 or D672. Therefore the Auto-Tuning Left or Right Flip-Flop will not be reset, resulting in continuing Auto-Tuning.

(b) Auto-Return

Auto-Return to left (Minus Return Signal) or right (Plus Return Signal) will be conducted respectively by VR303 or VR301. In an ordinary case, the stations to be selected exist between the preset points (each end). If Tuning Sensor is further touch-commanded to the direction where if there should not be any stations, the tuning-pointer will reach either left or right end of the tuning scale. When it reached either right or left end, the Tuning Motor will change its direction by automatically reverse its driving direction and continue until a station is detected. When detected, the Motor will stop there.

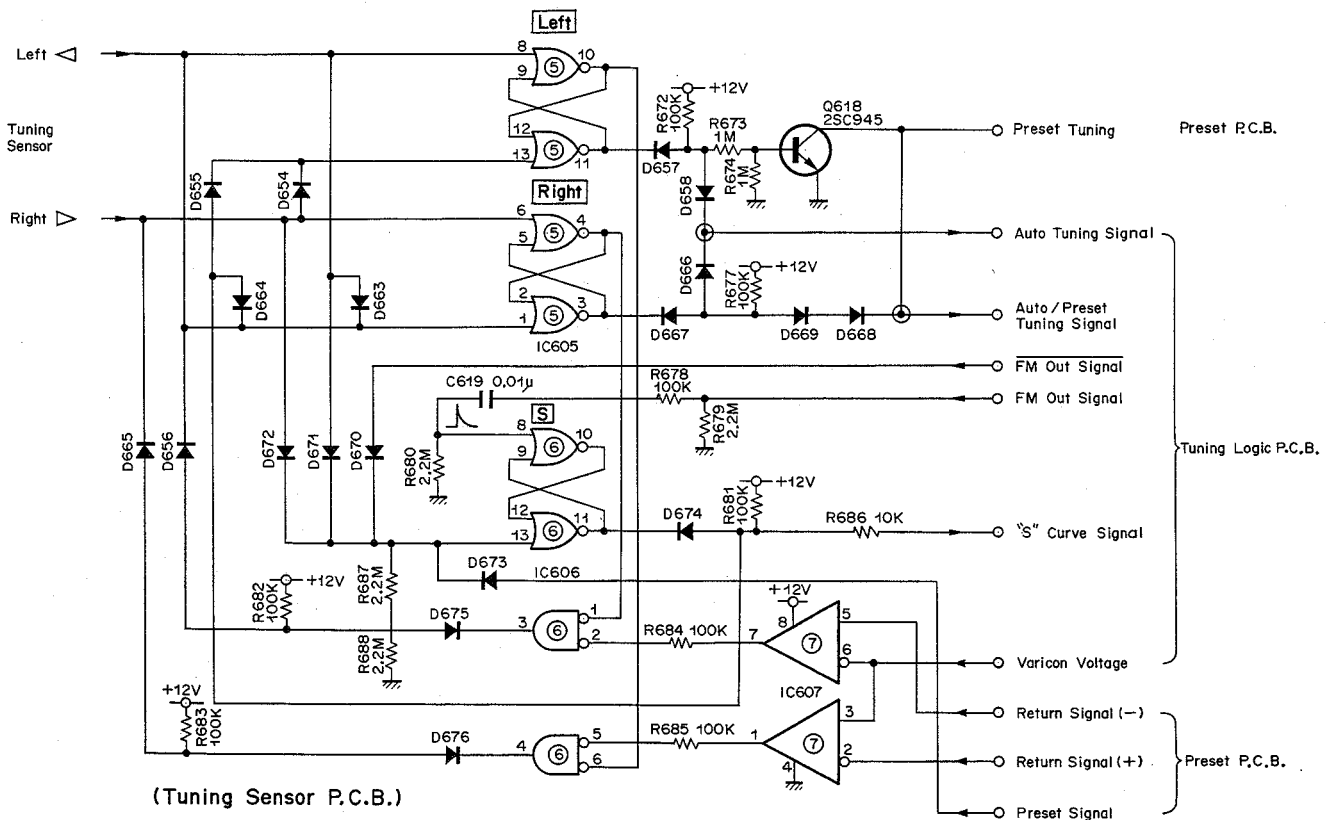

Fig. 2.4.11 Auto-Tuning Circuit

The IC607-5 and IC607-2 of the Tuning Sensor P.C.B. are provided with Minus Return Signal and Plus Return Signal, each determining left end or right end respectively. When the Varicon Voltage exceeds Minus Return Signal or Plus Return Signal level, IC607-7 or IC607-1 will become L.

Accordingly, gate IC606-5 and -6 will become L when the Auto Left Flip-Flop is set and exceeded the Minus Return. Thus IC606-4 will become H, the Left Flip-Flop is reset via D665 and Right Flip-Flop is set, thus the tuning direction will be reversed.

If the Auto-Right Flip-Flop is already set, gate IC606-1 and -2 will become L when Plus Return is exceeded, as a result of which IC606-3 will become H, Right Flip-Flop will be reset via D656, and further the Tuning Left Flip-Flop will be newly set and the tuning direction will be reversed.

(6) Tuning Lamps

Refer to Figs. 2.4.12 – 2.4.15.

While auto tuning process, both of the lamps will be lit if tuning has met the radio station. While preset tuning by means of a Preset Control however, either Right or Left Lamp will be lit if a station is detected. This way you can further proceed with tuning to search for a tuning point of approx. ± 70 kHz of center frequency, when both of the Lamps will be lit up. Further, both Lamps will not illuminate if a station is not detected. Pointer Lamp is lit up separately by power ON of the N-730. IC804-(3/4) compares the Mute Out Signal from the demodulator IC

of the IF Unit (refer to Fig. 2.4.13 showing the range of approx. ± 70 kHz of center frequency of a station) with approx. 1.5 V of IC804-11, and if Mute Out Signal should be smaller than 1.5 V, i.e. if entered a Hi-Fi tuning range, IC804-13 will become L.

IC804-(2/4) makes comparison of the voltage difference between AFC and Ref. and if AFC (IC804-9) is smaller than that of Ref. (IC804-8), IC804-14 will become L, and H if greater.

On the other hand, IC801-8, 13 is the gate input for lightening up the Tuning Lamp, where gate will be opened at L for lightening the Tuning Lamp. The conditions for IC801-8, 13 to become L are, anode of D808=L (i.e. the detected FM Out Signal becomes L through Station Detecting Circuit) and anode of D807=L (i.e. collector of Q805 is at L). Here the condition for collector of Q805 to become L, i.e. Q805 turns ON would be that the Motor is in stop mode (in case presetting process through the Preset Control, Motor stop condition (Q805 ON) is detected as described on later page).

Hereinafter described are the details of Q805 ON:

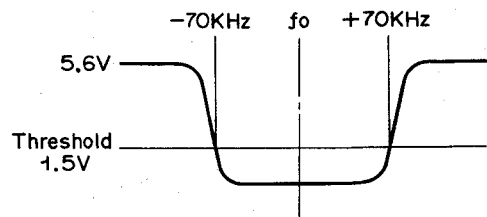

Fig. 2.4.13 Mute Out Signal

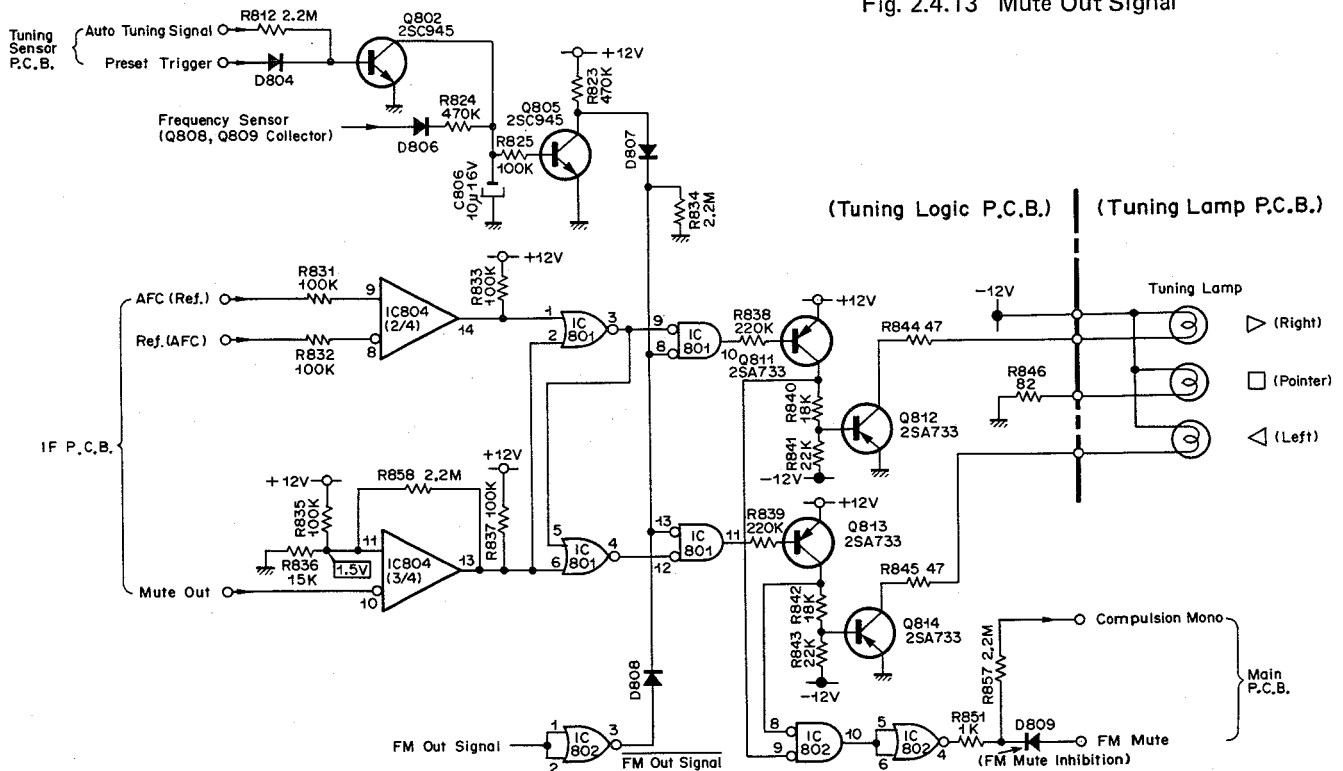

Fig. 2.4.12 Tuning Lamp Control Circuit

1) Auto Tuning

If Auto Tuning is completed, Q805 will turn ON and the Tuning Lamp will become ready for illuminating.

When auto tuning is directed, Auto-Tuning Signal will become H, Q802 will turn ON, C806 of the base of Q805 will discharge and then Q805 will turn OFF. When a station is detected (FM Out Signal=H), however, Auto-Tuning Signal will become L, as a result of which Q802 will again turn OFF. Further tuning is made and if the Tuning Motor stops, the Frequency Sensor output (collector of Q808 and Q809 of Motor Drive Circuit) will change from L to H, and when C806 is charged, Q805 will turn ON.

2) Tuning by Preset Control

When the Preset Control is manually turned for tuning, Q805 will turn ON and the Tuning Lamp will become ready for lightening. When Preset Control is turned manually, the Frequency Sensor output will detect both of the running and stoppage (L and H) of the Motor, but Q805 will retain its ON while tuning as the base of Q805 is provided with C806.

3) Preset Tuning

When Preset Tuning is completed, Q805 will turn ON and Tuning Lamp is now ready to illuminate. When either of the Sensors A, B, C or D is touch-commanded, Preset Trigger H pulse will be generated from the Preset P.C.B. This pulse will turn Q802 ON in the form of pulse through D804 of the Tuning Logic P.C.B., discharges C806 to decide the initial value of the electric charges to be 0. While the Motor is running to the preset broadcasting station, the Frequency Sensor output (Q808, Q809 collectors) is 0 V, therefore Q805 will turn OFF. When tuning is completed and Motor stopped its rotation, Q805 will turn ON.

(a) Illumination of Lamps at Tuning by Preset Control

1) No station is detected

As IC802-3 (FM Out Signal) is H, gate for illuminating lamps (IC801-8, 13) will become H, i.e. gate will become closed, and therefore both lamps will not illuminate.

2) Station is detected but out of tuning

Where a station is detected but tuned to the location other than the range of approx. ± 70 kHz of the center frequency of a station, IC802-3 (FM Out Signal) is L, and IC801-8, 13 becomes L as Q805 will be turned ON while tuning is made by the Preset Control, therefore gates will be opened for lightening the Tuning Lamps. When AFC voltage (IC804-9) connected to IC804-(2/4) is higher than Ref. voltage (IC804-8), IC804-14=H, therefore IC801-3, 9=L, and IC801-4, 12=H.

Accordingly, as IC801-9=L, IC801-10=H, Q811 is cut off and Q812 is turned ON, as a result of which the Tuning

Lamp Right lights ON.

When AFC voltage is lower than Ref. voltage, IC804-14=L, therefore IC801-3, 9=H, and IC801-4, 12=L. Accordingly, as IC801-12=L, IC801-11=H, Q813 is cut off and Q814 is turned ON, thus the Tuning Lamp Left lights ON.

3) Station is detected and tuned within ± 70 kHz of the center frequency

Where a station is detected and tuned to the location within a range of approx. ± 70 kHz of the center frequency of a station, Mute Out Signal will change its level from 5.6 V to low level as shown in Fig. 2.4.13.

Therefore Mute Out Signal becomes low with respect to the threshold voltage of IC804-11, and IC804-13 becomes H. Accordingly, IC801-3, 9 and IC801-4, 12 become L regardless of the output of IC804-(2/4) (AFC-Ref. comparator), therefore IC801-10, 11 becomes H, Q811 and Q813 are cut off, and Q812 and Q814 are turned ON, thus the both Tuning Lamps will be lit.

4) Detuned by further turning of Preset Control

When Preset Control is further turned, tuning becomes out of the range in the reverse order of above procedures and Tuning Lamps will go out.

When Mute Out Signal becomes higher than 1.5 V, i.e. tuning frequency becomes out of ± 70 kHz of the center frequency, one Tuning Lamp goes out but the other still lights ON. And when the detection of station becomes impossible, i.e. FM Out Signal becomes H, the other one Lamp also goes out.

(b) Preset Tuning by Station Memory Sensor A, B, C, or D

By touch-commanding Sensor A, B, C, or D preset-tuning point can be selected.

If a broadcasting station is preset, both Tuning Lamps will illuminate.

(c) Auto-Tuning

Both Tuning Lamps will illuminate, when detection of station is made by IC804-(4/4), tuning frequency is detected to be in a range of approx. ± 70 kHz of a center frequency by IC804-(3/4), and Q805 turns ON resulting from the detection of the Tuning Motor stoppage.

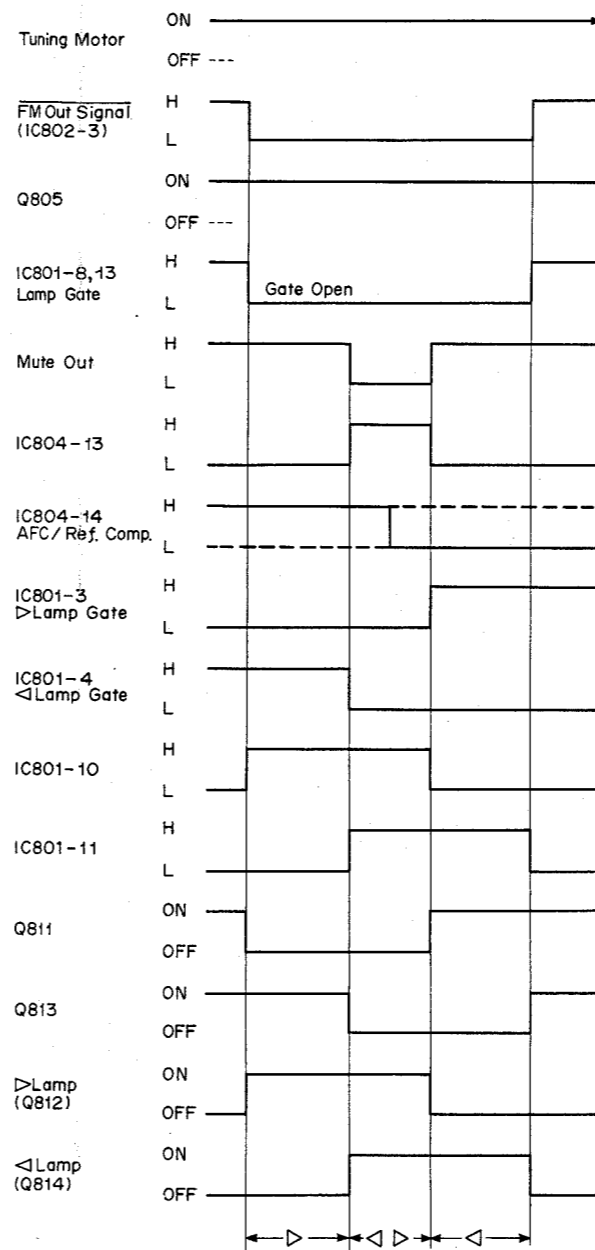

Fig. 2.4.14 Preset Tuning Timing Chart

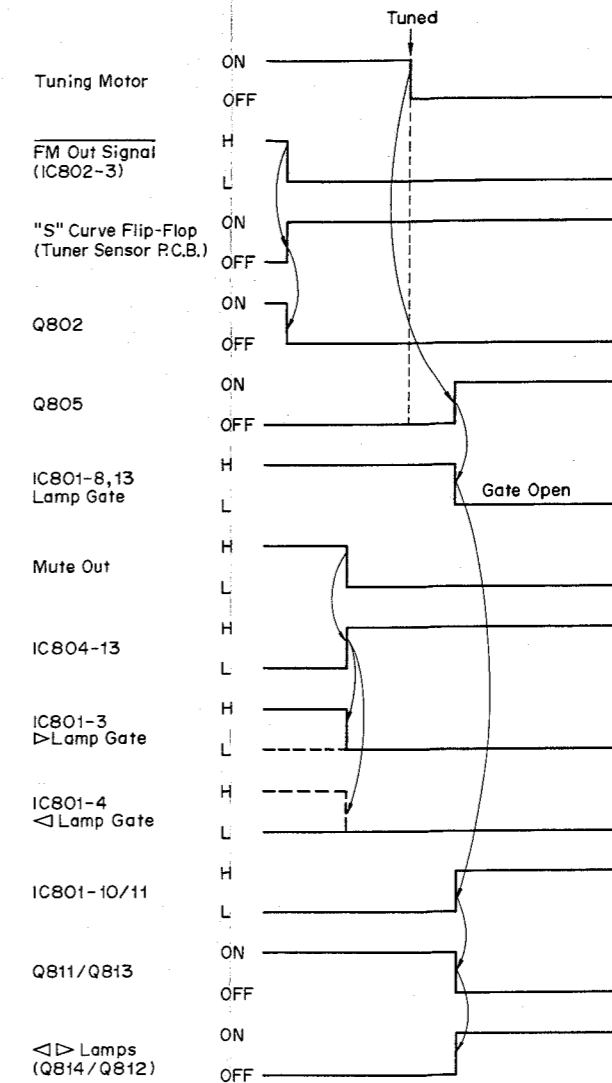

Fig. 2.4.15 Auto-Tuning Timing Chart

(7) FM Mute and Compulsion Mono

Refer to Fig. 2.4.16, circuit diagram.

(a) FM Mute

Each output terminal is muted by the H level of FM Mute Signal, but FM muting will be released if both Tuning Lamps light ON at the tuned condition.

Either when FM Mute Flip-Flop is set by touch-commanding the FM Mute Sensor, or Compulsion Mute becomes L through the driving of the Tuning Motor while FM Mute Flip-Flop is reset, Q608 of the Tuning Sensor P.C.B. turns ON, as a result of which, at FM Mode (i.e. when D619 is opened), FM Mute Signal becomes H and FM Mute Lamp lights ON. (Compulsion Mute will not become L when tuning is manually made through Preset Control.)

FM Mute=H signal is fed to Main P.C.B. and enters to the Mute Generator (Q309 and Q308) through Q304 and D312 under the condition that D336 is cut off (i.e. Source Mode (Source/Tape=H)).

Thus Q309 and Q308 will be turned ON. Then Q106, Q107, Q206 and Q207 will be turned ON to mute the Recording Output Terminals, Q109 and Q209 will be turned ON to mute the input of the Output Buffer Amp.

(IC303-(1/2) and (2/2)), and then Q102 and Q202 of the Tone Control P.C.B. will be turned ON to mute the Preamp. Output Terminals.

On the other hand, the output of Q304 (FM Mute=H) is directly fed to Q106, Q107, Q206 and Q207 through D309 to mute the Recording Output Terminals.

Note that, FM Mute is released when both Tuning Lamps are illuminated showing complete tuning.

At this time, both inputs of IC802-8 and -9 of the Tuning Logic P.C.B. become L, therefore IC802-4 will become L. Accordingly, FM Mute Signal of the Main P.C.B. will become L because this signal is grounded through diode D809 and R851 (1 kΩ).

(b) Compulsion Mono

While out of tuning, IC802-4 becomes H, therefore Compulsion Mono Signal becomes H, as a result of which MPX output will become monaural.

When tuning is made and both Tuning Lamps light ON, IC802-4 becomes L, therefore FM Mute Signal will be forcedly changed to L through D809 and Compulsion Mono Signal will become L resulting in releasing Mono.

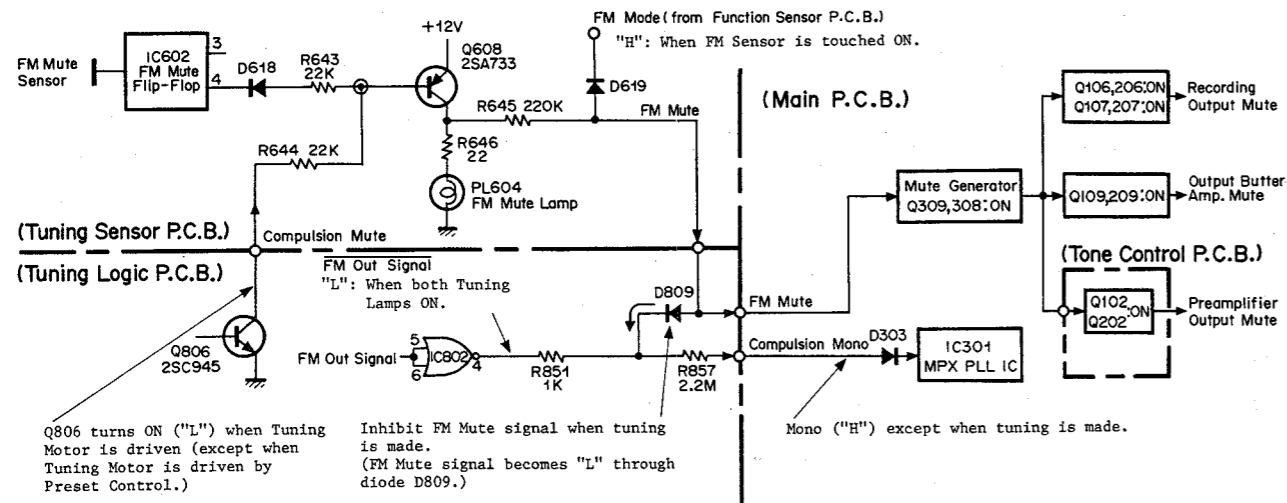

Fig. 2.4.16 FM Mute and Compulsion Mono

2.5. Amplifier Section

2.5.1. Phono Eq. Amplifier

The Phono Eq. amplifier in the N-730 employs a triple transistor configuration combined with a low-noise operational amplifier IC in the first stage in order to obtain a high S/N ratio. The triple-transistor system has already been used in Nakamichi's Models N-410, 610 and 630. Fig. 2.5.1 shows the circuit configuration, and Fig. 2.5.2 the noise equivalent circuit.

The thermal noise produced by the transistor base input resistor, h_{ie} , is given by the following equation:

$$E_n = \sqrt{4KT h_{ie} B}$$

- where, K: Boltzmann's constant (1.38×10^{-23})
- T: Absolute temperature
- B: Frequency band

When a signal source is connected here, its impedance, R_s , is connected in series with the h_{ie} . The thermal noise produced by the total input resistance, R , is given by the following equation:

$$V_n = \sqrt{4KTRB}$$

where, $R: h_{ie} + R_s$

As shown in Fig. 2.5.2 (a model of a transistor showing the noise components), the signal source impedance R_s is connected in series with the transistor base input resistance, h_{ie} .

Because the signal source impedance, R_s , is normally larger than h_{ie} , the thermal noise produced by h_{ie} , E_n , has, in many cases, been ignored.

However, if R_s is very low, as in an MC cartridge (of the order of several tens or hundreds of ohms), then h_{ie} will greatly affect the S/N ratio. To reduce E_n , the N-730 employs the triple-transistor system – a circuit with three transistors connected in parallel – to decrease h_{ie} by a factor of 3, thus E_n is reduced to $1/\sqrt{3}$ of the conventional level. Furthermore, the N-730 uses a low-noise operational amplifier IC, which, together with the above system, reduced the noise level to -137 dB or less. The characteristics of semiconductors generally differ to some extent. To avoid differences of offset voltage due to differences in semiconductor elements, a semi-fixed variable resistor is inserted between the positive power source and the positive voltage terminal of the Phono Eq. Amplifier to regulate the offset voltage and obtain a low distortion factor.

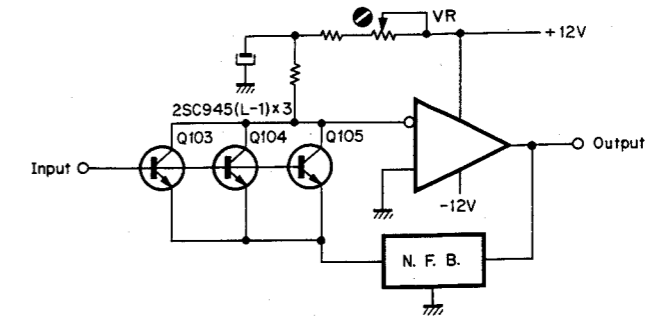
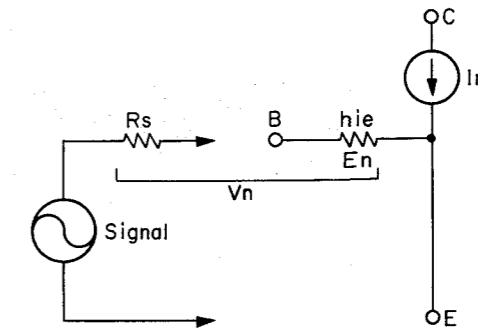

Fig. 2.5.1



- In: Transistor current noise
- R_s : Signal source impedance
- h_{ie} : Transistor base input resistance
- E_n : Thermal noise by h_{ie}
- V_n : Thermal noise by R_s and h_{ie}

Fig. 2.5.2

2.5.2. Recording Output Buffer Amplifier

Refer to Fig. 2.5.3. Sources for FM, Aux, Phono, Tape 1, and Tape 2 enter OR circuits after passing through bilateral switches. One output of these sources is used for recording output, and enters the buffer amplifier.

The buffer amplifier uses a low-noise operational amplifier IC, and its output can be continuously varied. Because R_1 and VR_1 of the buffer amplifier used in the N-730 are 10 kΩ and 20 kΩ, respectively, the gain is given as follows:

$$A_{VR1 \text{ min.}} = \frac{10 \text{ k} + 0}{10 \text{ k}} = 1 \quad (0 \text{ dB})$$

$$A_{VR1 \text{ max.}} = \frac{10 \text{ k} + 20 \text{ k}}{10 \text{ k}} = 3 \quad (9.54 \text{ dB})$$

Consequently, the output can be continuously varied from 1 to 3 times the input voltage. A muting circuit is connected with the recording output, and the signal is muted by a Mute signal, and Tape 1 or 2 is selected with the function sensor. (Recording output 1 is muted when the Tape 1 mode is selected.)

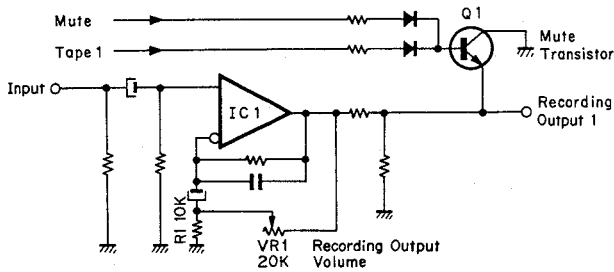

Fig. 2.5.3 Recording Output Buffer Amp.

2.5.3. Output Buffer Amplifier

Refer to Fig. 2.5.4. This circuit is a buffer amplifier in the first stage of the volume control circuit, and has a gain of 2 times.

$$A = \frac{R_1 + R_2}{R_1} = \frac{1\text{ k} + 1\text{ k}}{1\text{ k}} = 2 \text{ (6 dB)}$$

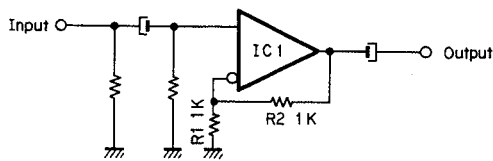

Fig. 2.5.4 Output Buffer Amp.

2.5.4. Tone Control

Refer to Figs. 2.5.5 – 2.5.7. The tone control section of the N-730 is in the last stage of the pre-amplifier section. It consists of an audio muting circuit, a tone control circuit, a mono circuit, a volume preset circuit and a balance control circuit.

The audio muting circuit is used as a kind of attenuator. The transistor Q1 is normally ON because no audio mute signal is supplied. The gain at this time is:

$$A = \frac{10\text{ k} + 2.2\text{ k}}{2.2\text{ k}} \cong 5.55 \text{ (14.88 dB)}$$

When the audio muting switch of the function sensor P.C.B. assembly is turned ON, an audio mute signal is supplied to Q1 turning it OFF, and the gain becomes:

$$A = \frac{10\text{ k} + 2.2\text{ k} + 100\text{ k}}{2.2\text{ k} + 100\text{ k}} \cong 1.1 \text{ (0.81 dB)}$$

Therefore, the audio mute signal is attenuated approximately by 14 dB when the audio muting switch is turned ON.

The tone control circuit is an NF-type tone control circuit, and no attenuation occurs in this circuit. This circuit is designed so as to control bass and treble tones independently without interference.

The volume preset control circuit uses a B-curve variable resistor, and the input is connected to its center tap. For no attenuation, the normal position on the variable resistor is at its center. When the sliding contact is moved to the right, it acts as an attenuator, and when it is moved

to the left, as a contour control volume.

When the sliding contact is moved to the left end of the resistor, the circuit shown in Fig. 2.5.7 results, and 20 Hz and 20 kHz signals are amplified approximately by 11 dB and 9 dB, respectively, when the 3 kHz level is taken as 0 dB. When the sliding contact is moved to the right end of the resistor as shown in Fig. 2.5.6, the signal can be attenuated approximately by 20 dB without changing acoustic characteristics. When a monaural signal is supplied, RL301 is turned ON and Lch and Rch are mixed to obtain a monaural state. The output of the tone control circuit is muted by a Mute signal.

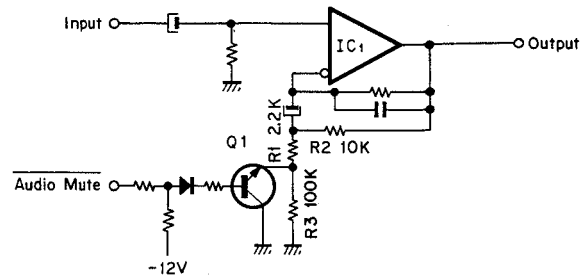

Fig. 2.5.5 Tone Control

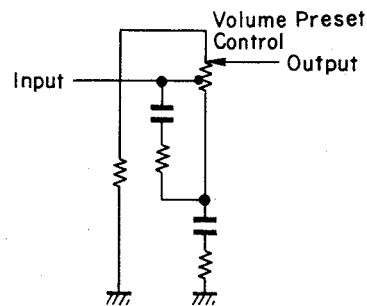

Fig. 2.5.6 Attenuator

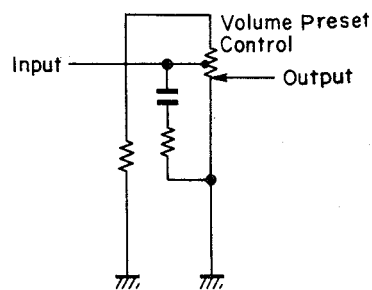

Fig. 2.5.7 Contour Control

2.5.5. Power Amplifier

(1) Pre-stage (Voltage Amplifier)

Refer to Fig. 2.5.8.

As all the output stage consists of emitter-followers, the voltage gain is approx. 1. Therefore, the gain required for power amplifier and NFB is obtained at the pre-stage. Generally, an increase in the number of transistor stages of an amplifier circuit increases distortion and phase shift. In large current amplification as seen with a power amplifier, a certain extent of distortion cannot be avoided and should be limited through use of NFB. However, excessive NFB is likely to cause unstable amplification as a result of phase shift in the amplifier or differences in loudspeaker impedance. This is one of the drawbacks inherent to an NFB amplifier.

The power amplifier used in the N-730 employs 8 transistors, of which only two serve for voltage amplification and the remaining six are used to provide the former two with the best operating conditions. A gain of approx. 100 dB is obtained through these two transistors to perform power amplification and NFB. The amplifier of this configuration assures stable NFB with low noise and low distortion and with little phase shift.

Q001, Q007: for voltage amplification

Q002, Q003: current mirror circuit (the same current at both collectors)

Q005, Q008: constant-current source

Q006: for impedance conversion (emitter follower)

Q004: Q004 and Q001 make up a differential amplifier circuit. Thus, stable NFB is applied through a circuitry using these transistors.

C005: determined the high-band characteristic of the voltage amplifier to prevent NFB from becoming unstable because of unbalanced performance of transistors, etc.

R016: resistor for NFB (signal)

R019: resistor for NFB (DC)

(2) Output Stage (Power Amplifier)

In the N-730 for making a bias voltage, varistor used in the conventional design of amplifier is replaced with transistor base-emitter so that the N-730 design improves bias stability (against temperature or current changes) with lower distortion.

Especially for a class B push-pull amplifier, distortion cannot be reduced unless the positive and negative signal amplifiers are well balanced. The amplifier in the N-730, however, is best balanced thanks to the vertically and horizontally symmetric configuration as shown in Fig. 2.5.8. This circuit allows distortion of only 0.1% at 1 kHz 105 watts output even without NFB. This degree of distortion is low enough to make the amplifier used as a high-fidelity unit even if it is given no NFB.

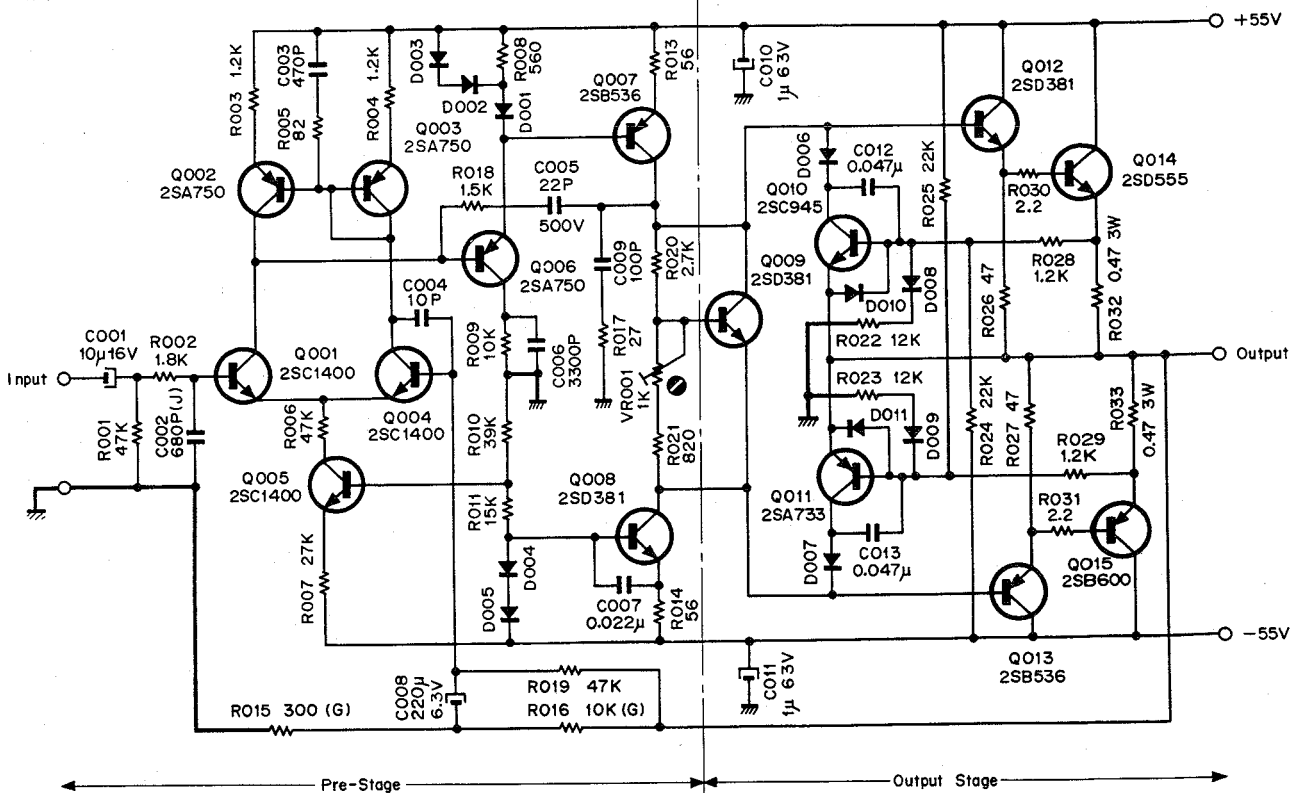

Fig. 2.5.8 Power Amplifier

Fig. 2.5.9 shows that a change in current flowing across the diode varies the terminal voltage and that E_B changes with signal current. These changes result in the generation of distortion. It is a matter of course that signal current flowing across the diode will produce distortion. See Fig. 2.5.8. Transistor Q009 that generates bias voltage form an emitter-follower circuit of class A operation. Thus this circuit does not induce distorted signals.

To utilize the action of each element fully, the N-730 allows the idling current to be varied. Therefore, an appropriate bias voltage can be supplied, and the rise of temperature when no signal is input can be minimized and a low distortion factor can be obtained.

Unless corrected perfectly against temperatures, the bias voltage of power amplifiers in the class B amplifier will increase distortion at low temperature or become unstable at high temperature. It may safely be said that temperature compensation of a transistor can be more properly and effectively carried out by the transistor of the same structure than a diode.

For an ordinary class B amplifier, crossover distortion is reduced by increasing idling current thus overlapping the operating ranges of the positive and negative transistors. The overlap portion acts as a class A amplifier. Generally, the degree of amplification decreases where a change takes place from class A to B and no linear curve is obtained as shown a thick continuous line in Fig. 2.5.10 (A). However, if the circuit shown in Fig. 2.5.8 is current-driven, a linear curve can be obtained at the point of change from class A to B as shown in Fig. 2.5.10 (B).

The V_{be} voltage of a transistor usually varies depending on its temperature, and decreases as temperature rises. Therefore, if a constant voltage is supplied to V , as in Fig. 2.5.11, the idling current increases with temperature rise, and the danger of damage to the transistor arises. In order to obtain a certain idling current over a wide range of temperature, this problem can be solved by varying according to the temperature change of V_{be} of the power transistor. This is accomplished by using the same type of transistor as Q_1 to the bias circuit, and by the thermal connection of this transistor with the output Darlington circuit.

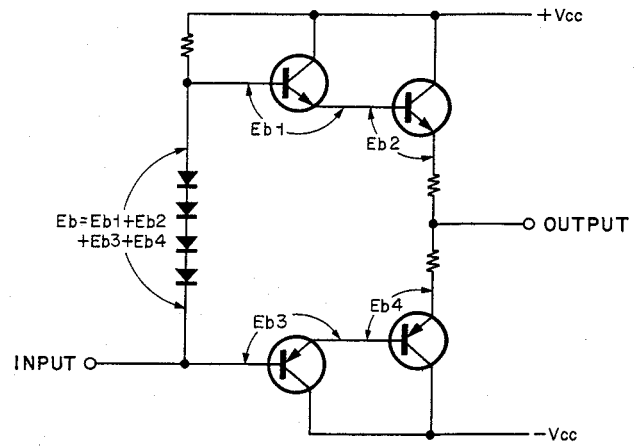

Fig. 2.5.9 Conventional Circuit

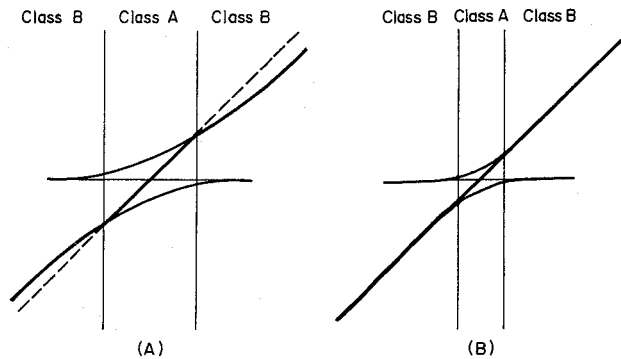
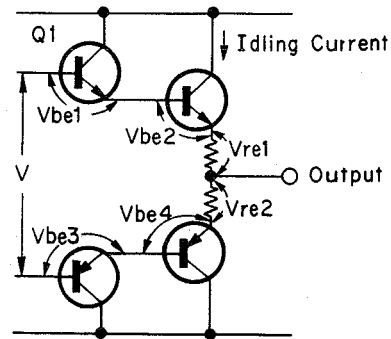

Fig. 2.5.10



$$V_{be} : (\text{Idling Current}) \times R_e$$

$$V = V_{be1} + V_{be2} + V_{be3} + V_{be4} + V_{re1} + V_{re2}$$

Fig. 2.5.11

Fig. 2.5.12 shows the bias circuit of the N-730. The voltage V_2 is given by the following equation:

$$\begin{aligned} V_2 &= V_1 + I_2 R_2 \\ &= I_1 R_1 + I_1 R_2 + I_B R_2 \end{aligned}$$

In this equation, I_B can be ignored because the h_{FE} of transistors is high. Therefore,

$$V_2 \approx I_1 (R_1 + R_2) = V_1 \frac{R_1 + R_2}{R_1}$$

Since $V_1 (=V_{be})$ varies according to the temperature of the power transistor, the V_2 voltage also varies at the same time, and thus the idling current is stabilized against temperature change.

(3) Limiter

The limiter of the N-730 detects the V_{ce} of the transistor in the last stage of the circuit and controls the I_C of this transistor in order to protect it. Fig. 2.5.13 shows the limiter of the N-730. Since it is symmetrical, only one side is shown here.

The emitter voltage of the transistor Q1 is $V_{E1} = V_{E2} - I_C \cdot R_E$, and the base voltage is;

$$\begin{aligned} V_{B1} &= V_0 + (V_{E2} - V_0) \frac{R_0}{R_B + R_0} \\ &= \frac{R_0}{R_B + R_0} V_{E2} + \frac{R_B}{R_B + R_0} V_0 \end{aligned}$$

The limiter operates when the V_{BE} of Q1 is above 0.6 V. Therefore,

$$\begin{aligned} V_{B1} - V_{E1} &= \frac{R_0}{R_B + R_0} V_{E2} + \frac{R_B}{R_B + R_0} V_0 - V_{E2} \\ &\quad + I_C \cdot R_E \\ &= -\frac{R_B}{R_B + R_0} V_{E2} + \frac{R_B}{R_B + R_0} V_0 + I_C \cdot R_E \\ &= -\frac{R_B}{R_B + R_0} (V_{E2} - V_0) + I_C \cdot R_E \\ &\geq 0.6V \end{aligned}$$

$$\therefore I_C (\text{limit}) = \frac{0.6}{R_E} + \frac{1}{R_E} \cdot \frac{R_B}{R_B + R_0} (V_{CC} - V_{CE} - V_0)$$

In these equations, since V_0 is a reference voltage determined by R_0/R_1 , it is constant; and since V_{CC} is the supply voltage, it is also constant. Therefore, $I_C(\text{limit})$ is indicated as a parameter determined by the change of V_{CE} . A diode, D1, is used to protect Q1 when an abnormal reverse voltage is applied.

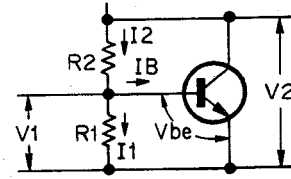

$$\begin{aligned} V_1 &= V_{be} \\ I_2 &= I_1 + I_B \\ I_1 &= \frac{V_1}{R_1} \therefore V_1 = I_1 R_1 \end{aligned}$$

Fig. 2.5.12 Bias Current

When V_{B1} exceeds 0V (ground level), D2 is turned ON causing R_0 and V_0 , and also the limiter curve, to be changed. When D2 is ON, R_0' and V_0' are defined as follows:

$$\begin{aligned} R_0' &: R_0 \parallel R_1 \\ V_0' &: V_0 \text{ divided by } R_0 \text{ and } R_1 \end{aligned}$$

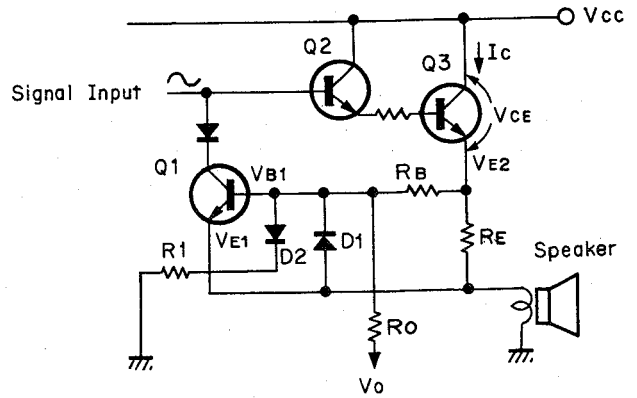

Fig. 2.5.13 Limiter Circuit

2.5.6. Protector Circuit

The protector circuit consists of the DC-voltage-detection circuit of the speaker terminals, the temperature-detection circuit of the heat sink, the muting circuit will activate, when the power switch is ON, and the circuit to disconnect the speakers when the headphone is plugged in the headphone jack A.

When a DC voltage above approx. 1.2 V (plus or minus) appears on the speaker terminals, the output of the DC detection circuit is at the ground level, and Q704 is turned ON and Compulsion Power Off signal is output. This signal resets the power switch flip-flop in the Function Sensor P.C.B. The capacitors C703 and C704 between the input of the DC detection circuit and the ground are used to delay the signal. This is to prevent the action of the protector circuit when a momentary signal is supplied to the speaker terminals, so that the protector circuit is allowed to act only when a prolonged signal is supplied. The time for charging these capacitors differs according to the DC voltage at the speaker terminals: when the DC voltage is high, the circuit acts earlier and when the voltage is low, the circuit acts later. A plus voltage turns ON D704 and Q707, and turns OFF Q709 and Q706; and a minus voltage turns ON Q709 and Q706, and turns OFF D704 and Q707.

The transistor Q708 on the heat sink is used for detecting the temperature of the heat sink. It is turned ON when the temperature is above 70°C, so that Q704 is turned ON to generate Compulsion Power Off signal, resetting the power switch flip-flop.

At the moment the power switch is turned ON, Q705 is turned ON; and when C702 is charged, it is turned OFF. This prevents the action of the protector circuit when a DC voltage is produced by an imbalance of the power amplifier at the moment the power switch is turned ON. The power muting when the power switch is turned ON is produced in the Function Sensor P.C.B., and when this signal (Power Mute) is high, RL701 is in a cutoff condition because of power muting. Only when the Power Mute signal is low D701 and Q703 are turned ON, resulting in the turning ON of RL701 and the connection of the output of the power block assembly to the speaker terminals.

The speakers are disconnected only when the headphone is plugged in the headphone jack A, the GND switch built into the headphone jack A is opened, and Q701 is in the cutoff condition. Then, Q702 is turned ON, Q703 is turned OFF, and RL701 is turned OFF so that the speaker terminals are disconnected from the power block assembly.

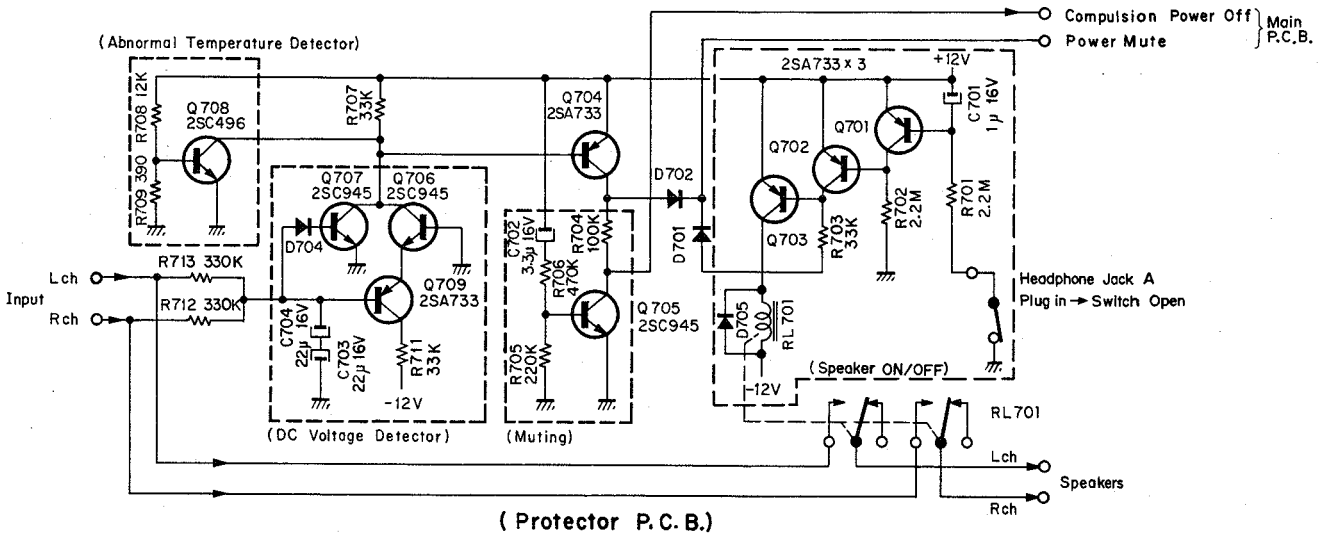

Fig. 2.5.14 Protector Circuit

2.6. Remote Control Unit RM-730 (Optional)

2.6.1. Introduction

The RM-730 is a remote controller for the N-730 consisting of a transmitter and a receiver. The transmitter transmits infrared control information which is received by a photosensitive diode in the receiver. The information is amplified and transmitted to the N-730 in order to control the tuning, volume, power supply and the auto-tuning of the N-730. See Fig. 2.6.1.

The control information is in the form of pulses with a frequency of approx. 30 kHz, transmitted with infrared rays.

Each unit of information consists of 7 bit and is transmitted in 7 ms. The first of the 7 bit is the start bit, the others being information bit. There is a time interval of 120 ms between each 7-bit unit of information and the next. See Fig. 2.6.2.

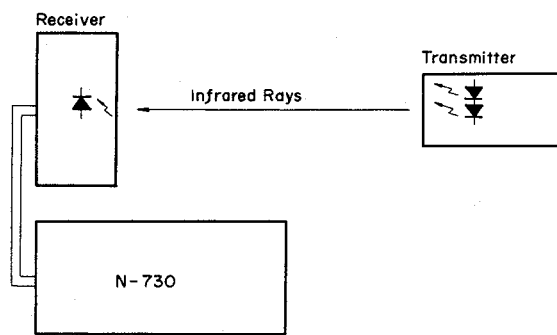

Fig. 2.6.1 RM-730 Connecting Diagram

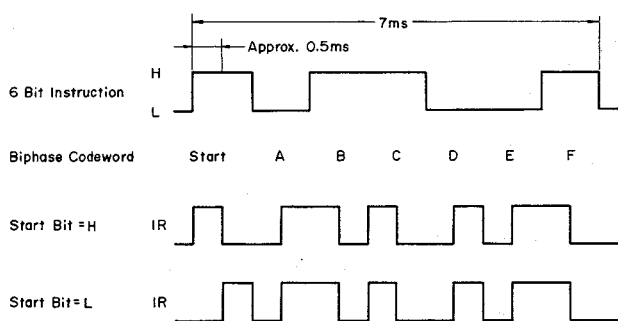

Fig. 2.6.2 Information Unit

2.6.2. Transmitter

The transmitter consists of a matrix key having various operation switches, a system IC for transmission, and an LED driving unit. See Fig. 2.6.3.

(1) Matrix key

The matrix key consists of nine microswitches: power, stations A, B, C and D, tuning (2), and volume control (2).

(2) System IC for transmission

The system IC for transmission consists of IC501, the turn-ON transistor Q501, and an additional clock generator circuit.

Terminal No. 1 is connected to a positive power source and Terminal No. 6 is grounded through Q501. Since a battery is used in the RM-730, it is designed so that the power is consumed only when the matrix key is depressed and the information is transmitted.

When one of 1 to 8 and one of a to d of the keyboard scanning section of IC501 are shortcircuited, the turn-ON control section within the IC causes the voltage level at Terminal 7 of IC501 to become H. Then, Q501 is turned ON, Terminal 6 of IC501 is grounded, and the information is given from Terminal 8 through the output section. Terminals 2 to 5 correspond to a to d, and Terminals 9 to 16 correspond to 1 to 8 of the keyboard scanning section. If 1 and a of the keyboard scanning section are shortcircuited, a unit of information is generated, and if 1 and b are shortcircuited, another unit of information is generated. Thus, 32 kinds of information can be obtained from Terminal 8 through the output section. The external circuit of the clock generator used to make the pulses for information transmission is connected to Terminals 17 and 18 of IC501. The frequency is determined by the adjustment of L501.

(3) LED driver

The LED driver consists of Q503 and Q502 connected to Terminal 8 of IC501, and photodiodes D504 and D505. It converts the output information into infrared signals having considerable power.

The signal from Terminal 8 of IC501 becomes the base current of Q503, whose collector current is the base current of Q502, and the collector current from Q502 flowing to LED's D504 and D505 acts to transmit the information. D501, D502, D503, R511 and R512 compose a protective circuit to restrict the current to the LED's.

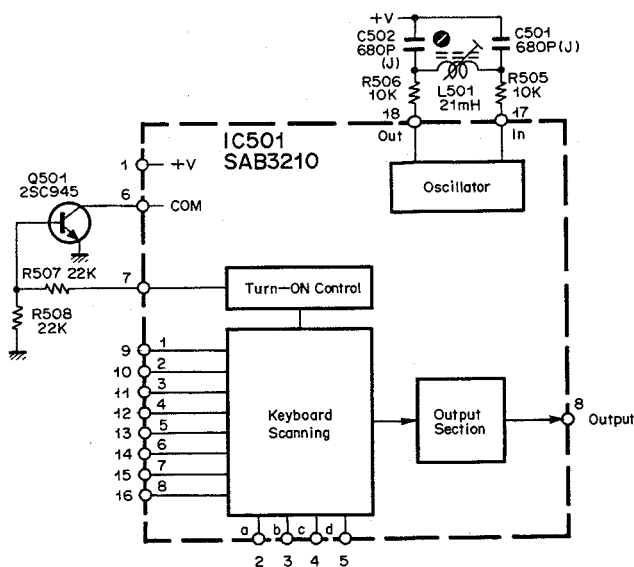

Fig. 2.6.3 Transmission IC System Diagram

2.6.3. Receiver

The receiver consists of a signal input, a signal amplifier, a system IC for reception, an instantaneous system IC power-disconnecting switch, a buffer amplifier, and an information processor.

(1) Signal input

The signal input consists of a photodiode D301, a transistor Q301, and a parallel resonance circuit.

The infrared signal radiated from the transmitter is received by the photodiode D301 and converted into a current. The current is amplified in the parallel resonance circuit consisting of C301, L301, and R302, and is further amplified by Q301.

The parallel resonance circuit is the most important part for remote control, and determines the distance at which remote operation is possible. This distance can be varied greatly by adjusting L301.

(2) Signal amplifier

The signal amplifier consists of IC301 and the surrounding circuits. IC301 is a specific frequency amplifier, operating at the information propagation frequency of approx. 30 kHz with an amplification of about 100 dB. This frequency is determined by R304, R305, R306, C304, C305 and C306.

(3) System IC for reception

The system IC for reception is IC302 shown in Fig. 2.6.4. Terminal 1 of IC302 is supplied with a positive power source and Terminal 17 is grounded. IC302 has a built-in clock-generator. An additional circuit is connected to Terminals 2 and 3 in order to make a frequency identical to that of the transmitter. The frequency can be adjusted by L302. The information signal from the transmitter is amplified by the signal amplifier and input at Terminal 15 of IC302. It is processed by a read-in register, and an output corresponding to the input is produced through program portion. Since the program portion has 4 kinds of output (A, B, C and D), 16 ($2^4 = 16$) kinds of output are produced. Terminal 16 of IC302 is called the DLEN terminal and is H only when an information signal is input.

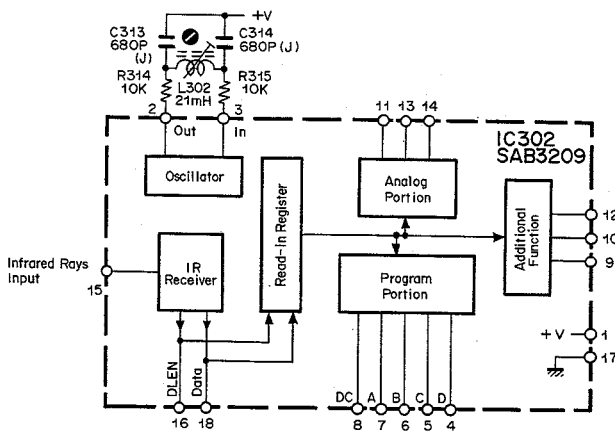

Fig. 2.6.4 Reception IC System Diagram

(4) Instantaneous power-disconnecting switch

See Fig. 2.6.5 timing chart.

The instantaneous power-disconnecting switch for the system IC for reception consists of Q302, Q303, Q304, and their peripheral circuits.

IC302 maintains its state when an information signal is output from the program portion, until the next unit of information is input. However, since the maintenance of this state affects the functioning of N-730, the information stored in the program portion must be cleared when the remote control button is released, and it is for this reason that the switching function of instantaneous power-disconnecting is provided to disconnect the power supply to IC302 and to clear the memory.

Q302 and Q303 form a monostable multivibrator. When no infrared signal is input through Terminal 15 of IC302, the DLEN Terminal (No. 16) is at the L level, and this signal enters Terminal 3 of IC303 acting as a buffer amplifier and output from Terminal 2 as L. This L output, as in the steady state, does not affect the monostable multivibrator, in which Q302 and Q303 are ON and OFF, respectively, and the collector of Q303, which is the output of the multivibrator, is H.

When an infrared signal is input through Terminal 15 of IC302, signals as shown in the figure are produced at Terminal 16. The same waveform is also produced at Terminal 2, and the waveform as shown in the figure at the base of Q302. This negative pulse turns Q302 OFF, and the waveform on the collector of Q302 is as shown in the figure. Further, the waveform in the figure is produced at the collector of Q303, being the output of the multivibrator. These signals are input to Terminal 5 of IC303, and the same waveform is output from Terminal 4, by this signal the transistor Q304, which supplies power to IC302, is momentarily turned OFF as shown in the figure, so that the program stored in IC302 is cleared.

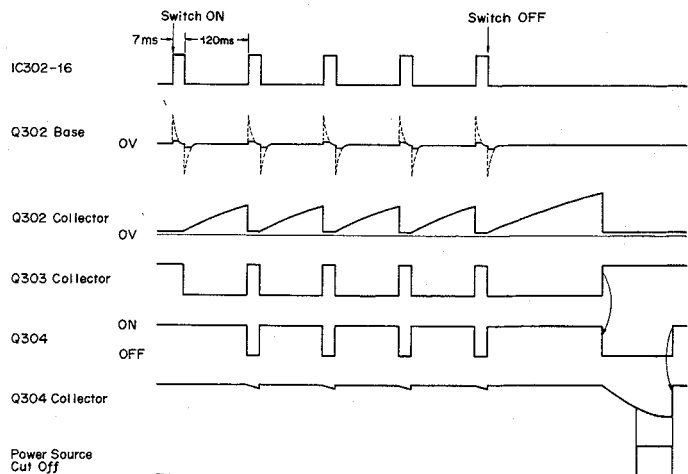

Fig. 2.6.5 Timing Chart

(5) Buffer amplifier

The buffer amplifier consists of IC303. IC303 is a non-inversion type C-MOS IC acting as a buffer amplifier.

(6) Information processor

The information processor consists of transistors Q305, Q306, Q307, Q308, Q309, Q310, Q311 and their peripheral circuits. It processes the 4-bit output signals from IC302 input as infrared information signals.

The table of information transmitted and the corresponding 4-bit signals output from IC302 is as follows:

Information	Signal Bit			
	A(7)	B(6)	C(5)	D(4)
Power	H	H	H	H
Volume ▷	H	L	L	H
Volume ◁	H	L	H	L
Station A	H	H	H	L
Station B	H	H	L	H
Station C	L	L	H	L
Station D	L	L	L	H
Tuning ◁	L	H	H	L
Tuning ▷	L	H	L	H

As shown in the above table, there are 9 kinds of information to be transmitted, and when power source and grounding are included, 11 bus lines are required. However, two signals for volume (◁/▷), tuning (◁/▷) and stations (A/B and C/D) are transmitted to and processed respectively in N-730 as one unit of information, so that control can be made with 8 lines. And then, for example, the volume ◁/▷ signal together with the L/R identification signal L make "Volume ◁", and the station A/B signal with the L/R identification signal R make "Station B". The L/R identification signal is the D signal from Terminal 4 of IC302, and uses L level as L and H level as R. Following signals will be transmitted to the Tuning Sensor P.C.B. through the Main P.C.B. according to the condition of L/R identification signal.

L/R identification signal:

L ... Station A, Station C, Volume ◁, Tuning ◁

R ... Station B, Station D, Volume ▷, Tuning ▷

The signal for power ON/OFF is produced from the collector of Q311. Q310 is turned OFF when all the output signals A, B, C and D are H. Only when the button of the transmitter is depressed, Terminal 4 of IC303 is made L and Q311 turned ON. Pulses are thus generated when Q311 is turned ON and turned OFF, and are transferred to the Function Sensor P.C.B. through the Main P.C.B.

The station A/B selection signal is produced at the collector of Q309. Only when both output signals A and B are at the H level, either or both output signals C and D are at the L level, and the button of the transmitter is depressed, Terminal 4 of IC303 becomes L, the base of

Q309, L, and the collector of Q309, H, and thus Q309 is turned ON. When Q309 is turned ON and turned OFF, pulses are produced and transmitted to the Tuning Sensor P.C.B. from the collector of Q309, through the Main P.C.B.

The station C/D selection signal is produced at the collector of Q308. When no information is transmitted from the transmitter, Q308 is turned ON. When output signals A and B of IC302 are L, and the button of the transmitter is depressed, Terminal 4 of IC303 becomes L, the base of Q308 L and Q308 is turned OFF. When Q308 is turned ON and OFF, pulses are produced and transmitted to the Tuning Sensor P.C.B. from the collector of Q308, through the Main P.C.B.

The volume operation signals are produced when Q307 is turned ON and OFF, and transmitted to the Function Sensor P.C.B. from the collector of Q307 through the Main P.C.B. The output signal A of IC302 is fed to the collector of Q307, and the output signal B of IC302 and the output signal from Terminal 4 of IC303 are connected to the base of Q307. The output from Q305 is also sent additionally to the base of Q307. The program stored in IC302 is cleared when the power is turned OFF. However, since program is preset, when the power is turned ON, so that the signal A is H and signals B, C, and D are L, it is necessary for making a volume operation signal to alter the circuit condition so that both signals C and D are not L. This condition is produced by Q305.

When both output signals C and D of IC302 are L, the base of Q305 is at the L level, and Q305 is not turned ON. Therefore, an H level voltage is applied to the base of Q307, and Q307 is not turned ON even if the other conditions are satisfied. The output signal of Terminal 4 of IC303 is L only when the button of the transmitter is depressed. The output signal B of IC302 is then L, and if either signal C or D (or both) is H, the base of Q307 becomes L. Further, the signal A is H, and H level voltage is impressed on the collector of Q307, and Q307 is turned ON.

The turning signals are produced by the ON-OFF operation of Q306, and transmitted to the Tuning Sensor P.C.B. from the collector of Q306 through the Main P.C.B. When the output signal B of IC302 is H, the output signal A is low, and the button of the transmitter is depressed, the output from Terminal 4 of IC303 becomes L, and Q306 is turned ON.

3. REMOVAL PROCEDURES

Note: To remove Covers and Heat Sink, use of the specially designed Hex. Wrench (whose length is long and provides easy access to hex. socket head screws in the Heat Sink) by Nakamichi Research Inc. is recommended.

Part No.: 0D03362B Hex. Wrench

3.1. Side Panel R

Refer to Fig. 3.1.

Remove F01 (Hole Plug) on the Rear Panel. Insert plus-screwdriver into the hole, then turn F02 clockwise.

Side Plate R will shift in the direction of rear panel side, then removal of F03 (Side Plate R) becomes possible.

3.2. Top Cover Ass'y, Bottom Cover A, Bottom Cover B, Bottom Cover C and Battery Cover Ass'y

Refer to Fig. 3.2. Remove Side Panel R referring to item 3.1.

Remove F01, F02 and F03, then F04 (Top Cover Ass'y). Remove F05 and F06, then F07 (Side Panel L). Remove F08, then F09 (Bottom Cover B). Remove F10, then F11 (Bottom Cover A). Remove F14, then F15 (Bottom Cover C). Remove F12, then F13 (Battery Cover Ass'y).

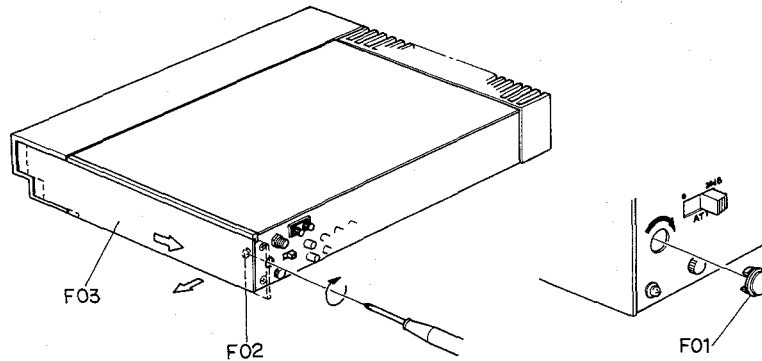

Fig. 3.1

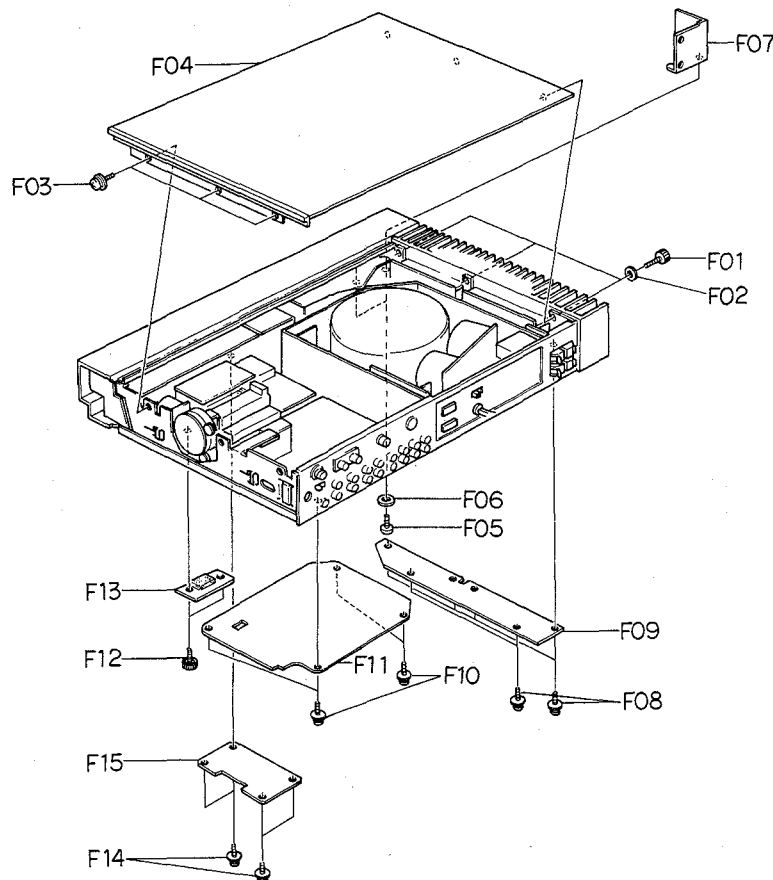

Fig. 3.2

3.3. Front Panel Ass'y

Refer to Fig. 3.3. Remove Side Panel R, Top Cover Ass'y and Side Panel L referring to items 3.1 and 3.2. Turn F01 (Front-end Reel Ass'y) fully clockwise by hand. Remove F02, F03 and 10 connectors, then F04 (Front Panel Ass'y).

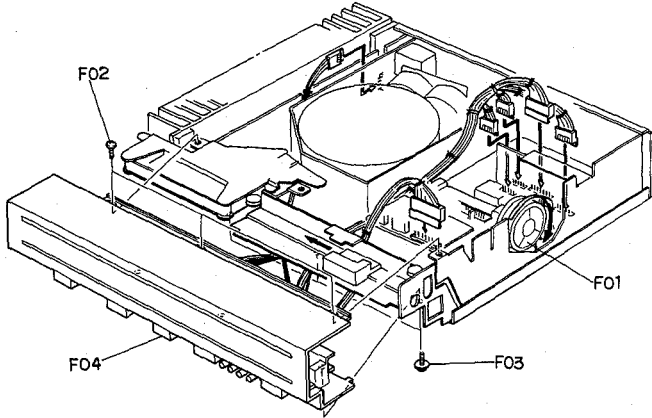

Fig. 3.3

3.4. Volume Lamp P.C.B. Ass'y

Refer to Fig. 3.4. Remove Front Panel Ass'y referring to items 3.1 – 3.3. Remove F01, then F02 (Lamp P.C.B. Cover).

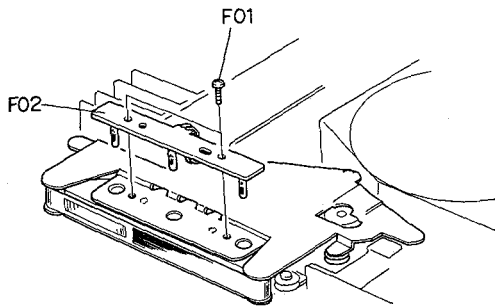

Fig. 3.4

3.5. Lamp P.C.B. Ass'y

Refer to Fig. 3.5. Remove Front Panel Ass'y referring to items 3.1 – 3.3. Remove F01 and F02 (Lamp P.C.B. Cover), then F03 (Lamp P.C.B. Ass'y).

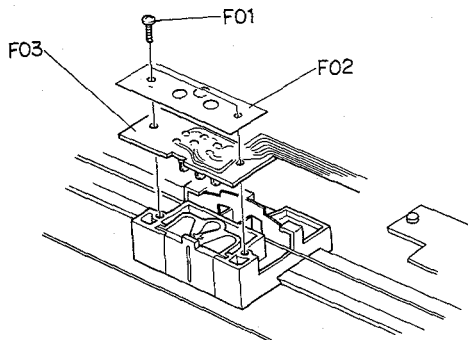

Fig. 3.5

3.6. Lamp Cover Ass'y

Refer to Fig. 3.6. Remove Front Panel Ass'y referring to items 3.1 – 3.3.

Loosen F01, remove F02, then F03 (Lamp Cover Holder). Remove F04 (Connector), then F05 (Lamp Cover Ass'y)

Note: When replacement of lamp is made on Lamp Cover Ass'y, detachment of F06 (Light Intercepting Seal) and unsoldering of signal wires of lamp are required.

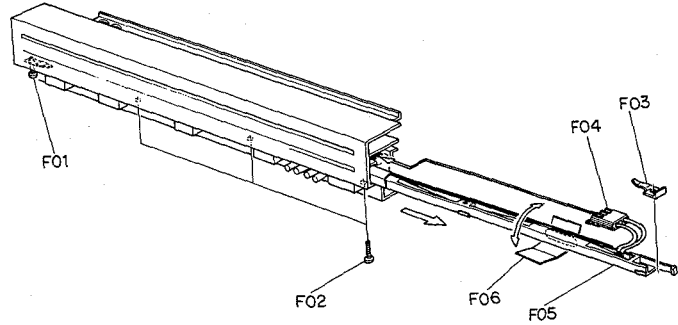

Fig. 3.6

3.7. Logic L Ass'y and Logic R Ass'y

Refer to Fig. 3.7. Remove Front Panel Ass'y referring to items 3.1 – 3.3.

Remove F01 and F02, then F03 (Logic R Ass'y). Remove F04 and F05, then F06 (Logic L Ass'y).

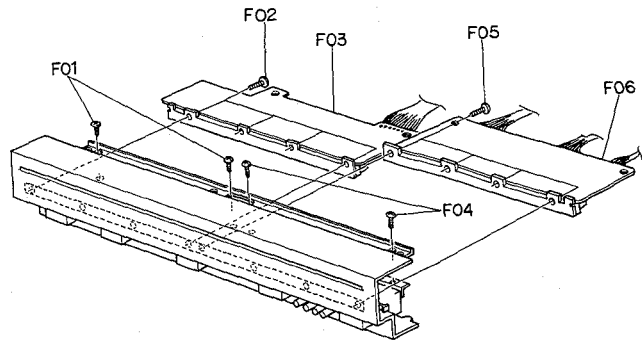

Fig. 3.7

3.8. Function Sensor P.C.B. Ass'y

Refer to Fig. 3.8. Remove Front Panel Ass'y and Logic R Ass'y referring to items 3.1 – 3.3 and 3.7.

Remove F01 and F02 (Logic P.C.B. Mask), then F03 (Function Sensor P.C.B. Ass'y) and F04 (Reflector R).

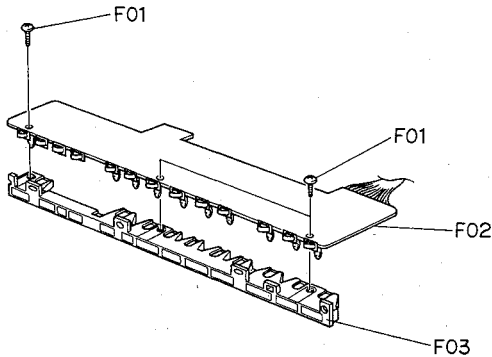

Fig. 3.8

3.9. Tuning Sensor P.C.B. Ass'y

Refer to Fig. 3.9. Remove Front Panel Ass'y and Logic L Ass'y referring to items 3.1 – 3.3 and 3.7.

Remove F01, then F02 (Tuning Sensor P.C.B. Ass'y) and F03 (Reflector L).

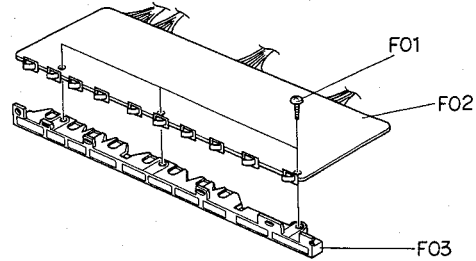

Fig. 3.9

3.10. Dolby NR P.C.B. Ass'y, Main P.C.B. Ass'y, Tuning Logic P.C.B. Ass'y, IF P.C.B. Ass'y, Tuning Lamp P.C.B. Ass'y, Volume P.C.B. Ass'y and Motor Base Ass'y (Volume)

Refer to Fig. 3.10. Remove Side Panel R and Covers referring to items 3.1 and 3.2.

Remove F01 and F02, then F03 (Dolby NR P.C.B. Ass'y). Remove F04, F05, F06, F07, F08, F09 (Connector), F10 (Connector) and the other connectors, then F11 (Main P.C.B. Ass'y). Remove F12, F13 (Connector) and the

other connectors, then F14 (Tuning Logic P.C.B. Ass'y). Remove F15, F16 and F17, then F18 (IF P.C.B. Ass'y). Remove F19 and F20, then F21 (Tuning Lamp P.C.B. Ass'y). Remove F22 and F23, then Volume Control Ass'y.

Remove F24, F25, F26, F27 and F28, then F29 (Volume Clutch Ass'y).

Remove F30 and F31, then F32 (Volume P.C.B. Ass'y). Remove F33, then F34 (Motor Base Ass'y (Volume)). and F35 (Base Holder A).

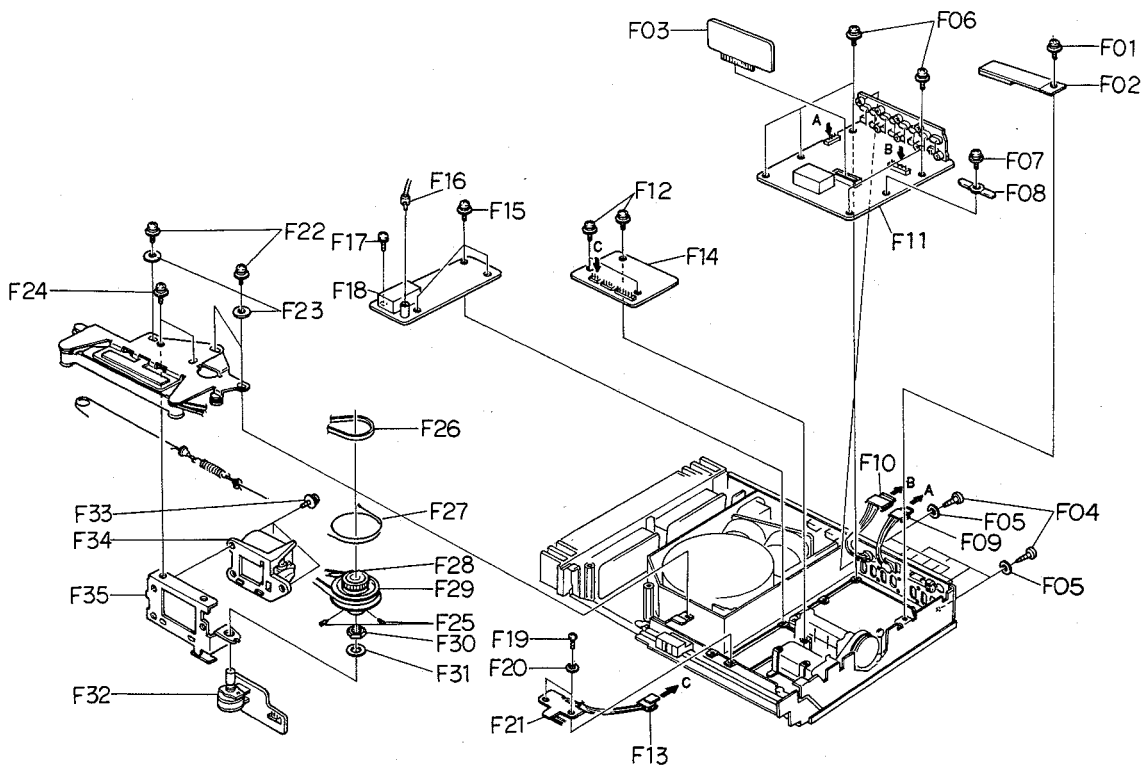

Fig. 3.10

3.11. Rear Panel Ass'y, Push Terminal, Remote Control Socket Ass'y, Record Output Volume Ass'y, 2P Terminal, Attenuator Switch Ass'y, Balun Transformer and Ground Terminal

Refer to Fig. 3.11. Remove Side Panel R and Covers referring to items 3.1 and 3.2.

Remove F01, F02, F03, F04, F05, F06, F07, F08, F09, F10 (Connector) and F11 (Connector), then Rear Panel Ass'y.

Remove F12, F13, F14 and F15, then F16 (Push Terminal). Remove F17 and F18, then F19 (Remote Control Socket Ass'y). Remove F20, F21, F22, F23 and F24, then F25 and F26 (Record Output Volume Ass'y). Remove F27, F28, F29 and F30, then F31 (2P Terminal) and F32 (Balun Transformer). Remove F33 and F34, then F35 (Ground Terminal). Remove F36 and F37, then F38 (Attenuator Switch Ass'y). Remove F39 and F40, then F41 (Coaxial Connector) and F42 (Rear Panel Ass'y).

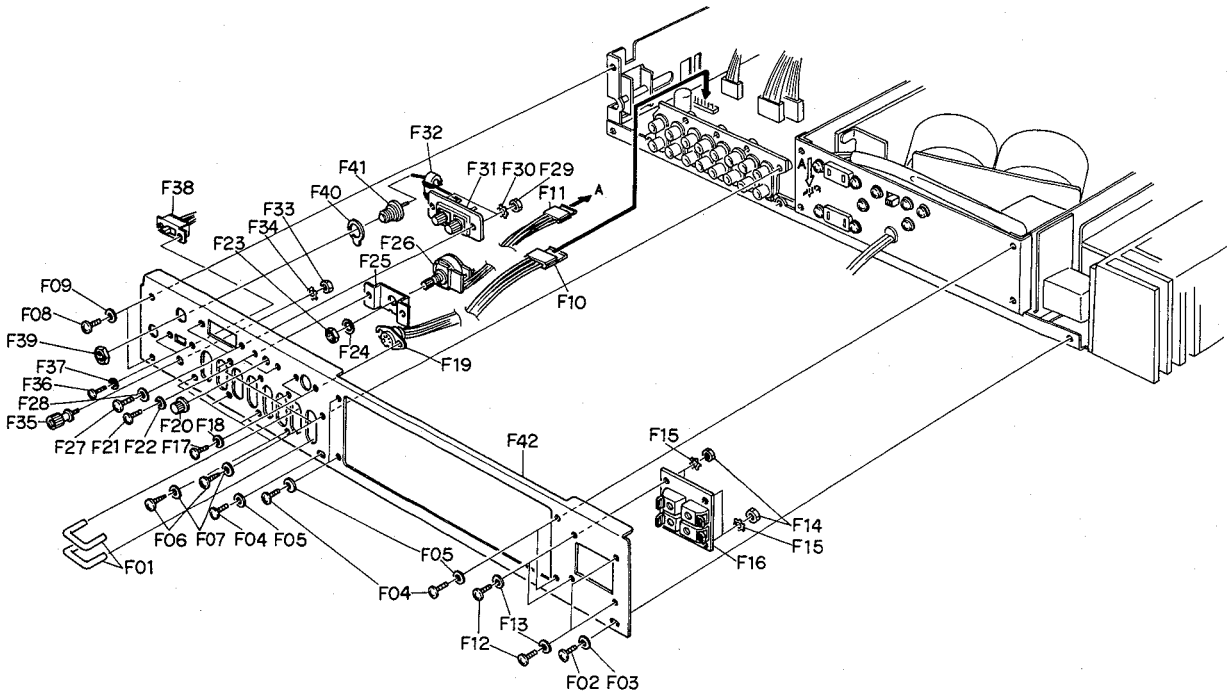

Fig. 3.11

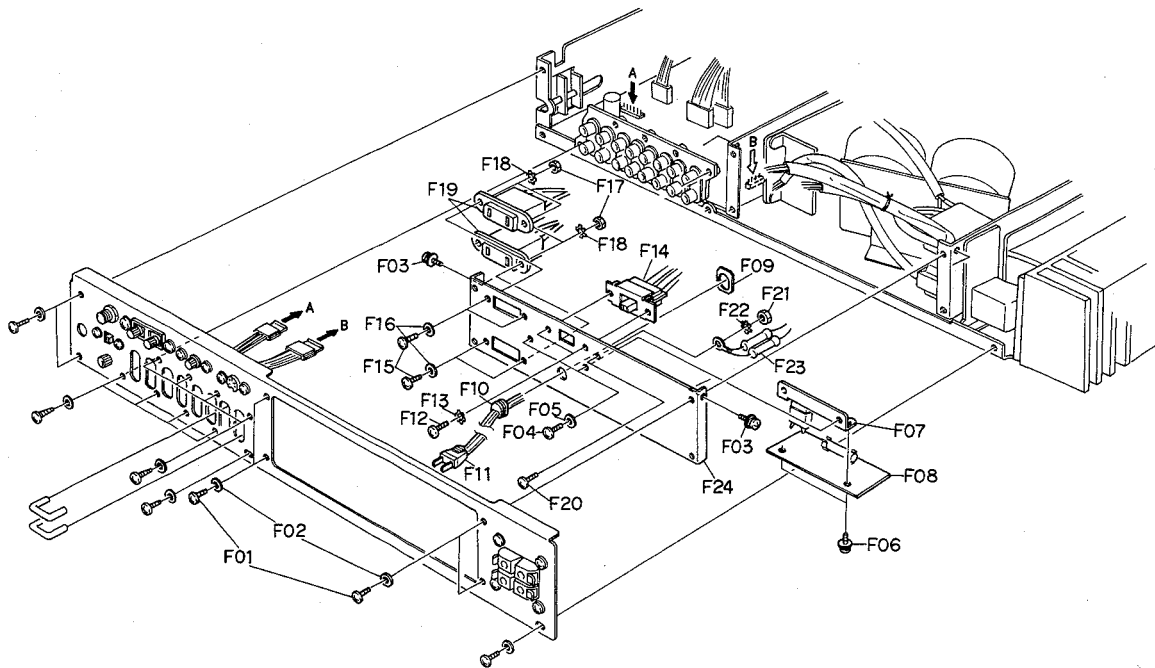

Fig. 3.13

3.12. Protector P.C.B. Ass'y, Power Transformer, Sub Transformer, Power Relay, Capacitor P.C.B. Ass'y, Power Supply P.C.B. Ass'y and Power Box

Refer to Fig. 3.12. Remove Side Panel R and Covers referring to items 3.1 and 3.2.

Remove F01, F02 (Connector), F03 (Connector) and F04, then F05 and F06 (Protector P.C.B. Ass'y). Remove F07, then Power Supply Ass'y. Remove F08, F09 and

F10, then F11 (Power Transformer). Remove F12, then F13. Remove F14, then F15 and F16 (Power Relay). Remove F17, then F18 and F19 (Sub Transformer). Remove F20, F22 and F23 (Diode Bridge), then F21 (Capacitor P.C.B. Ass'y). Remove F25, F26 and F27 (Power Supply P.C.B. Holder), then F28 (Power Supply P.C.B. Ass'y). Remove F29, F30 and F31 (Fuse P.C.B. Holder), then F32 (Fuse P.C.B. Ass'y) and F33 (Power Box).

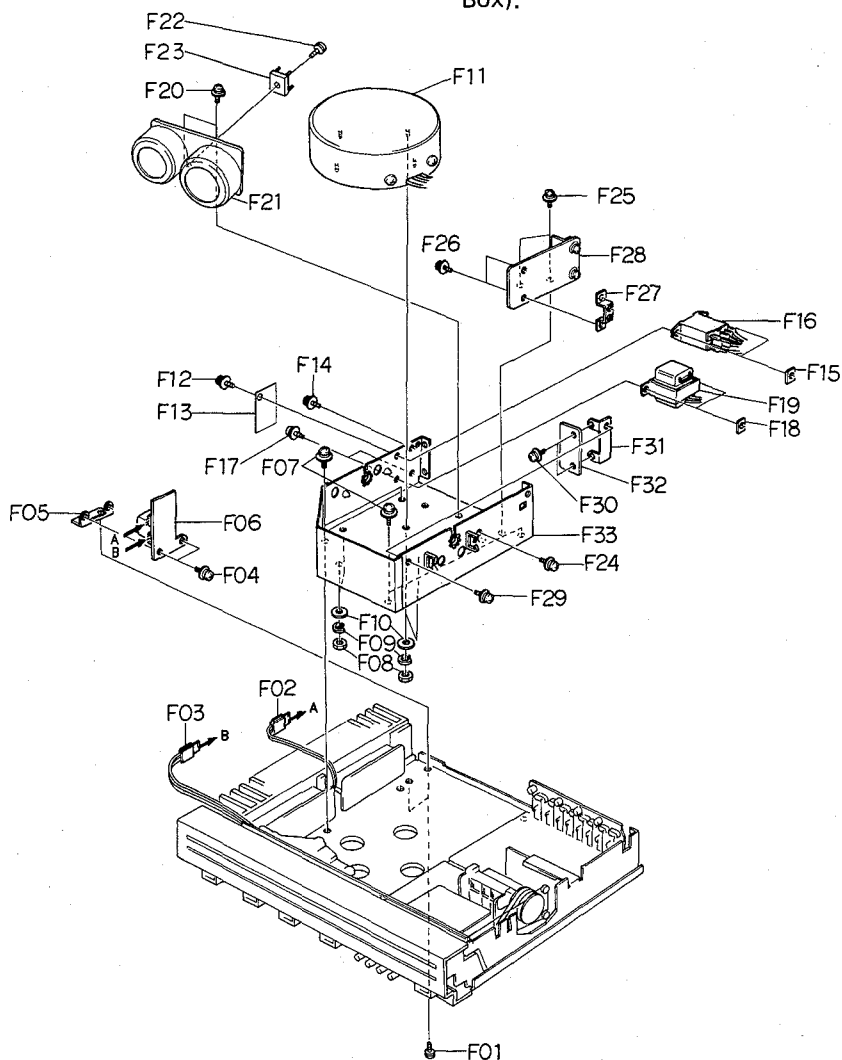

Fig. 3.12

3.13. Fuse P.C.B. Ass'y, Power Cord, Power Switch, AC Outlets and Power Supply Panel

Refer to Fig. 3.13. Remove Rear Panel Ass'y referring to item 3.11.

Remove F01, F02 and F03, then Power Panel Ass'y. Remove F04, F05 and F06, then F07 and F08 (Fuse P.C.B. Ass'y). Remove F09 and F10, then F11 (Power Cord). Remove F12 and F13, then F14 (Power Switch). Remove F15, F16, F17 and F18, then F19 (AC Outlets). Remove F20, F21, F22 and F23, then F24 (Power Supply Panel).

3.14. Side Panel, Power Block Ass'y, Thermal Transistor Ass'y, Output P.C.B. Ass'y, Power Amp. P.C.B. Ass'y, Transistor 2SB600, Transistor 2SD555, Heat Sink and Power Block P.C.B. Insulator

Refer to Fig. 3.14. Remove Side Plate R and Covers referring to items 3.1 and 3.2.

Remove F01, F02, F03, F04 and F05, then Side Panel Ass'y.

Remove F06 and F07, then F08 (Power Block Ass'y). Remove F09, F10 and F11, then F12 (Thermal Transistor Ass'y) and F13 (Side Panel).

Remove F14, F15 and F16, then F17 (Output P.C.B. Ass'y). Remove F18, F19, F20, F21, F22, F23 and F24, then F25 (Power Amp. P.C.B. Ass'y).

Remove F26, F27 and F28, then F29 (Transistor 2SB600), F30, F31 (Transistor 2SD555) and F32 (Heat Sink). Remove F33, then F34 (Power Block P.C.B. Insulator).

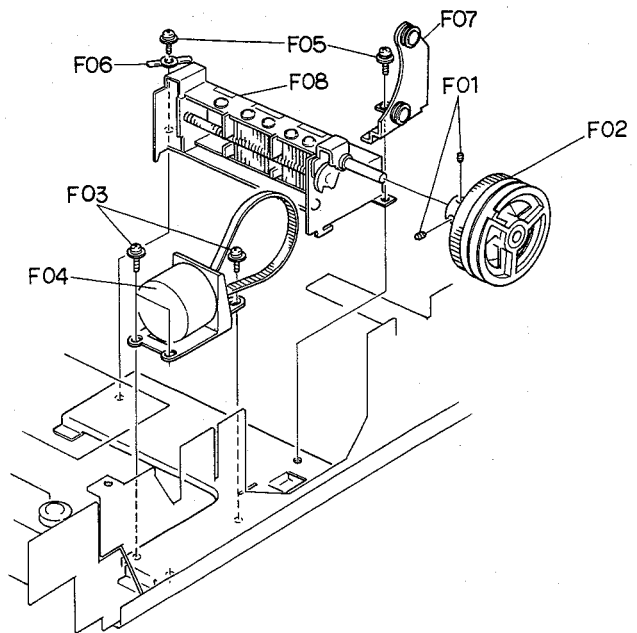

Fig. 3.15

3.15. Front-end Reel Ass'y, Motor Base Ass'y (Front-end), Pulley Holder and Front-end 730

Refer to Fig. 3.15. Remove Front Panel Ass'y referring to items 3.1 – 3.3.

Remove F01, then F02 (Front-end Reel Ass'y).

Remove F03, then F04 (Motor Base Ass'y (Front-end)).

Remove F05 and F06 (Wire Holder), then F07 (Pulley Holder) and F08 (Front-end 730).

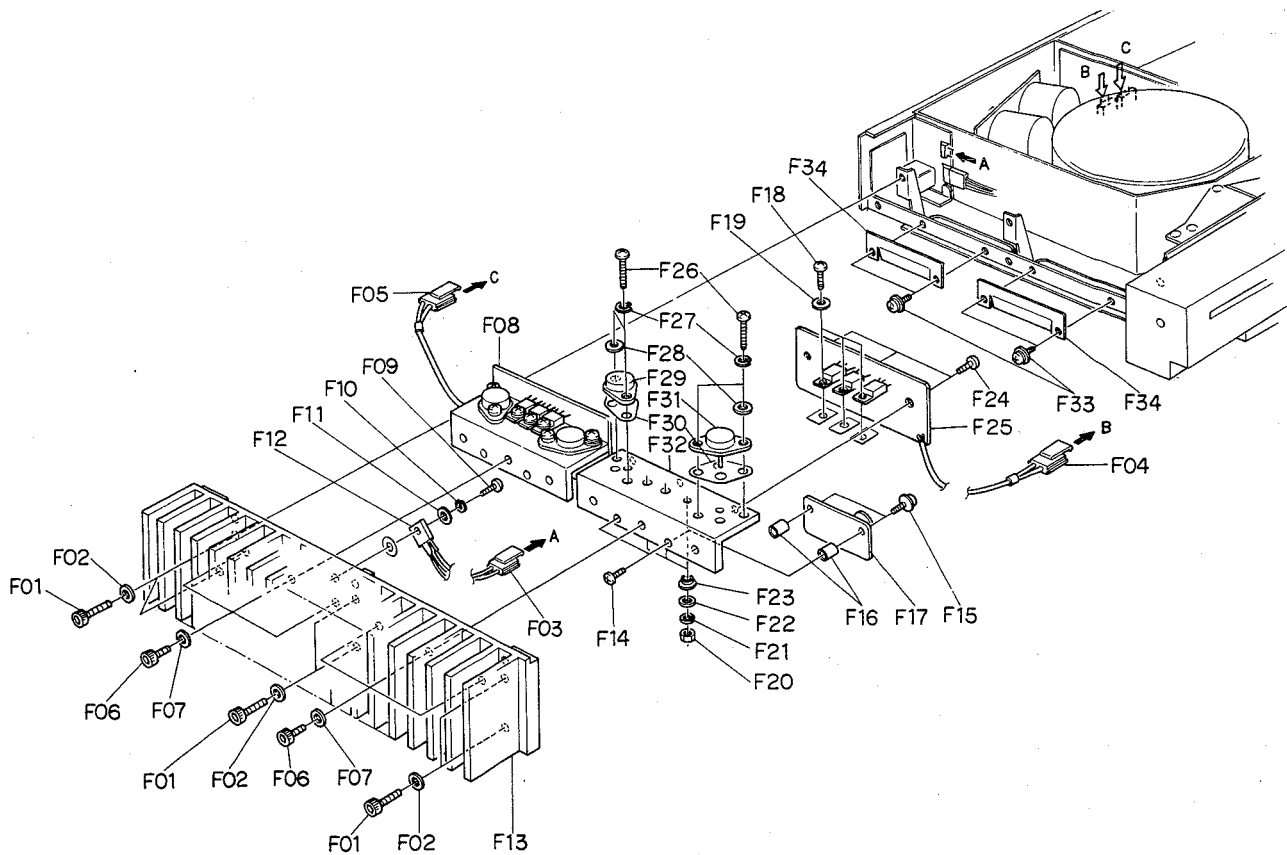

Fig. 3.14

4. ADJUSTMENTS AND MEASUREMENTS

N-730 consists of the following sections:

- (1) FM Tuner Section (including Auto-return Scale Calibration)
- (2) Preamplifier Section (including Volume Scale Calibration)
- (3) Power Amplifier

4.1. FM Tuner Section

4.1.1. Electrical Adjustments and Measurements

Fig. 4.1.1 is a connection diagram and Fig. 4.1.2 is a diagram for adjustment. Fig. 4.1.3 is a flow chart showing the adjustment procedures.

Instruments and devices used for adjustment and measurement are as follows (these or equivalent instruments and devices should be used):

Model 1700B Distortion Measurement System

Model 1100A Signal Conditioner

Model 1000A FM Alignment Generator

Dummy Antenna (an accessory to Model 1000A)

(The above mentioned are supplied from Sound Technology Inc.)

Oscilloscope (vertical gain: DC 0.05 V/cm or more)

Channel Switch Box

As distortion of N-730 is less than 0.1% in Mono, the measuring device must keep its distortion much lower than that of N-730.

However the built-in oscillators of ordinary FM generators are not recommendable for the adjustment and measurement. The oscillator of M-1700B is preferable for such purposes.

Measurement and adjustment must be performed in a shielded room in principle; otherwise, the frequency should be selected so that no broadcasting frequency will become in a range of the selected frequency ± 400 kHz. With all the instruments normally connected, make RF level of M-1000A FM alignment generator to be minimum and then with Audio Mute of N-730 turned OFF (release), find out a frequency band in which no signal is received by turning Station Preset Control (with Station Memory Sensor ON) of N-730, while listening interstation noise. A point of any noise tone variation should be avoided because there will be some weak radio frequency. In this adjustment and measurement, the frequency meeting the above requirements should be set, for example, to 98 MHz on the M1000A FM alignment generator.

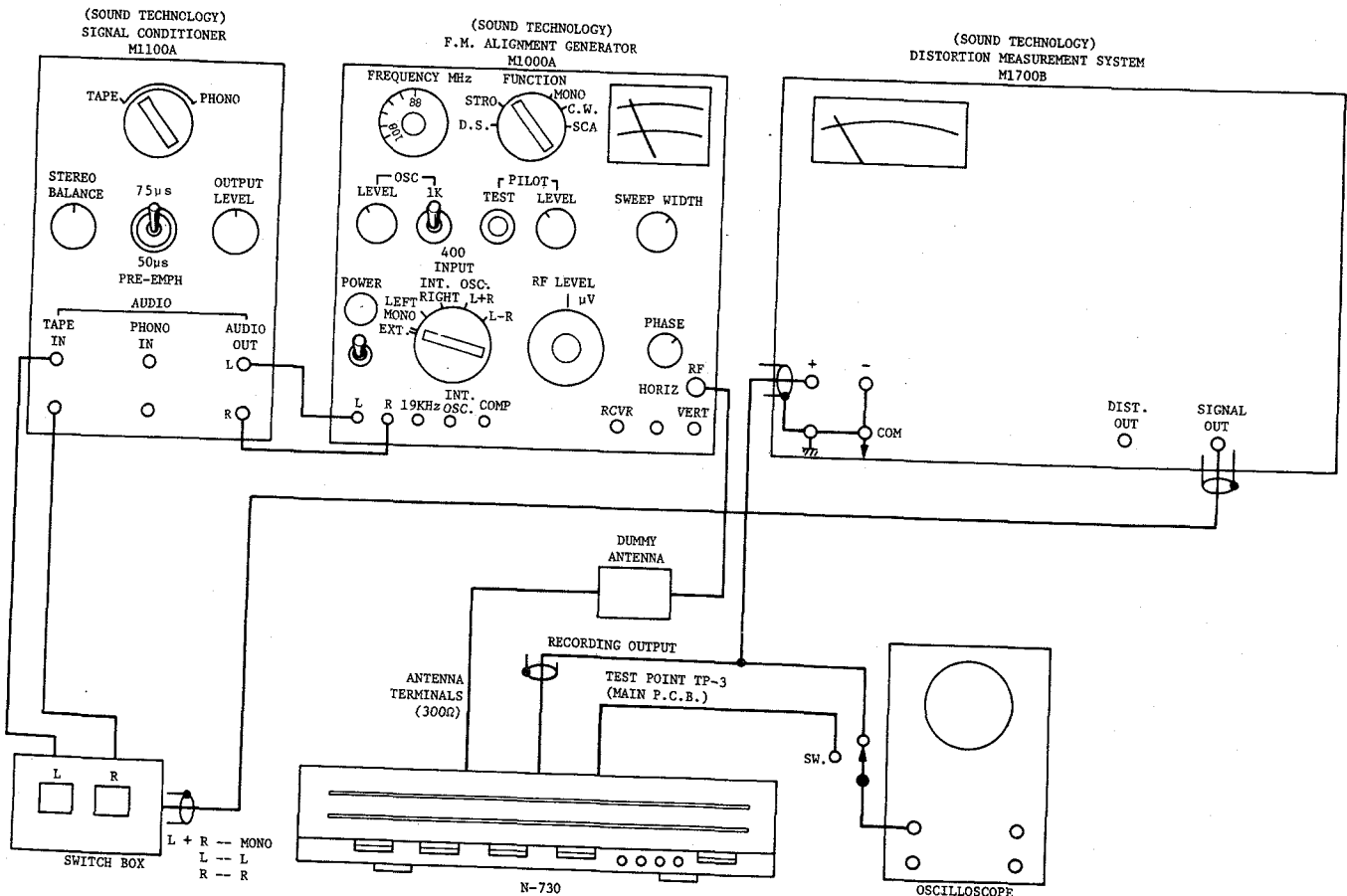

Fig. 4.1.1 Connection Diagram

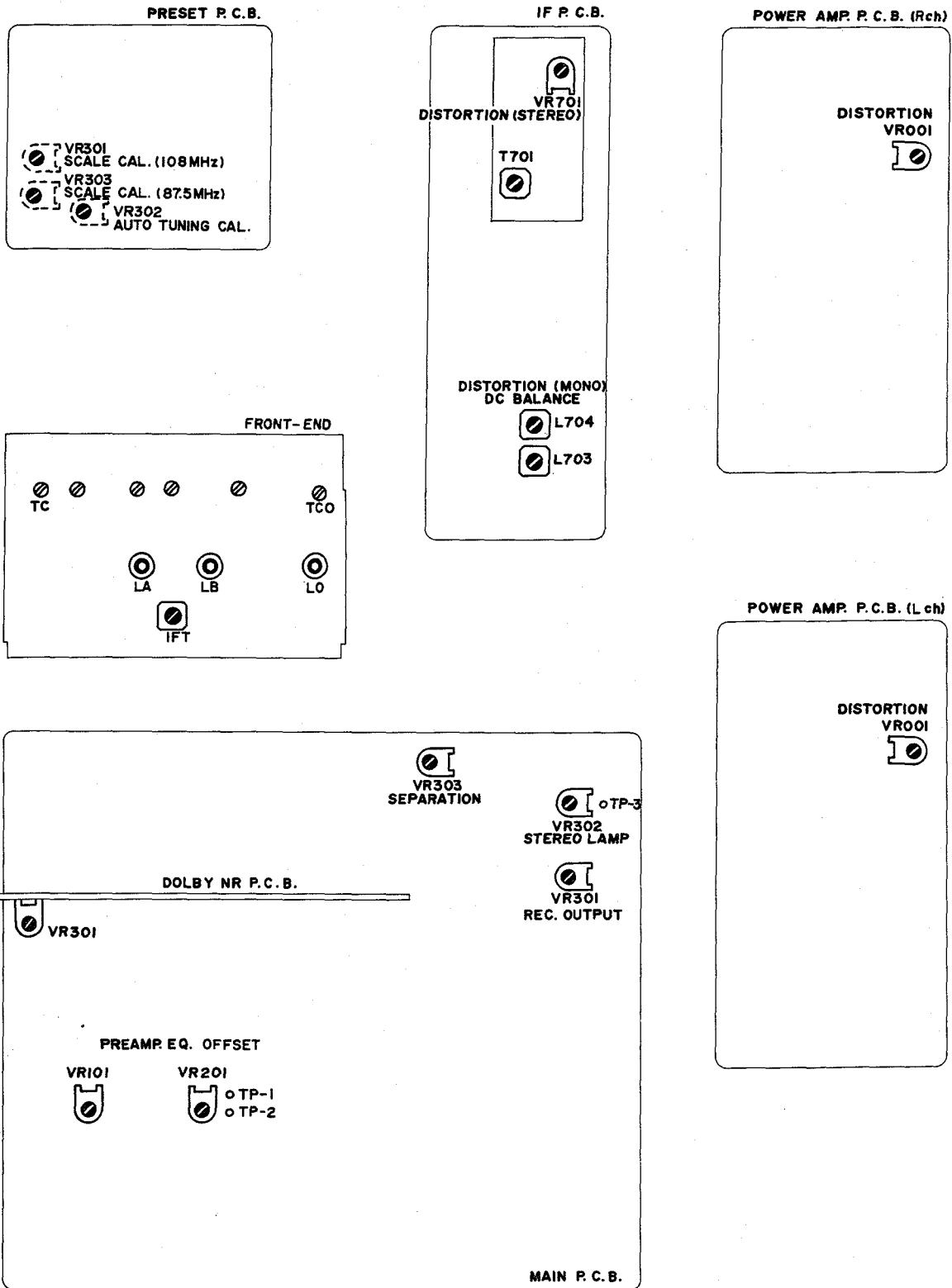

Fig. 4.1.2 Diagram for Adjustment

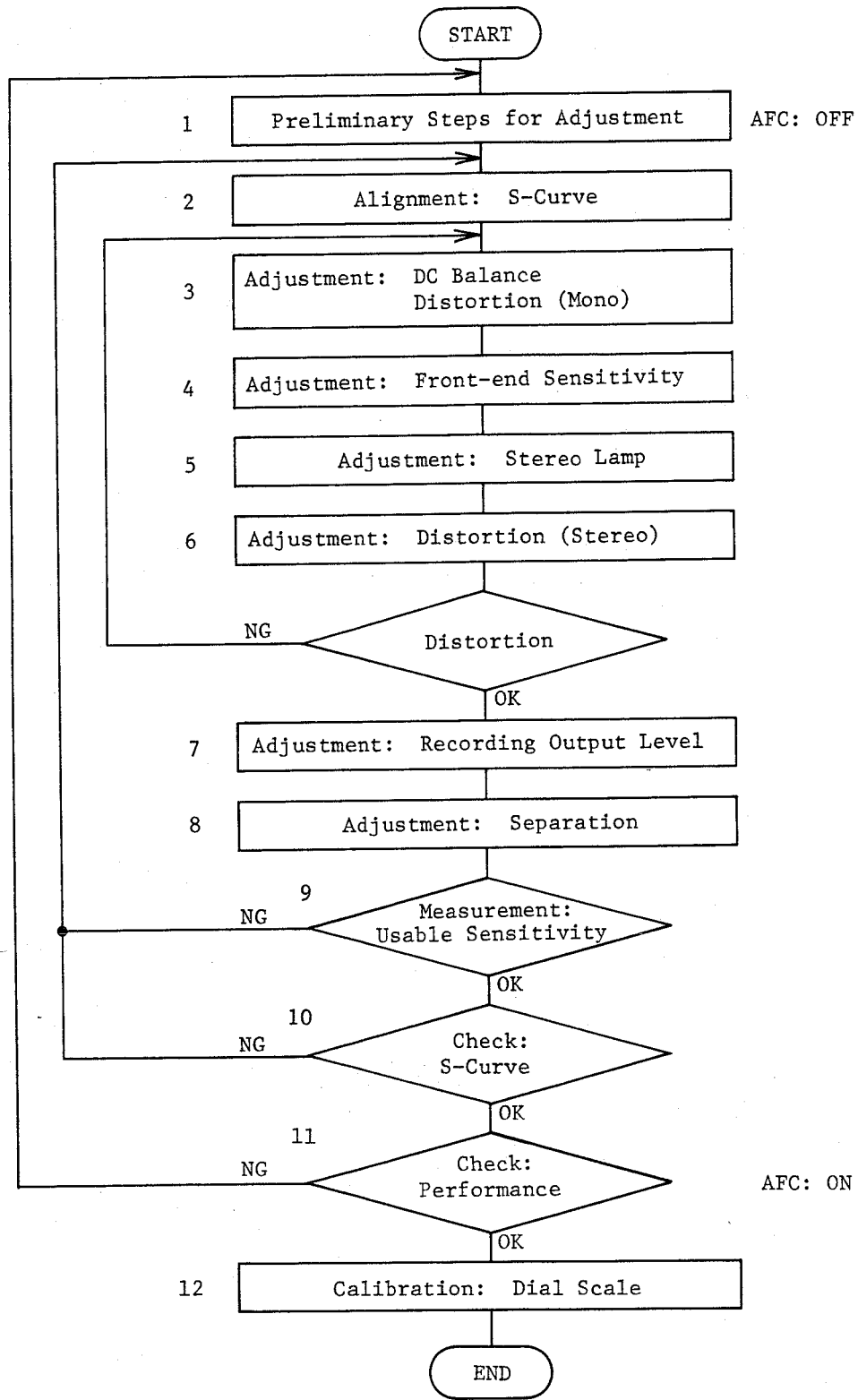

Fig. 4.1.3 Adjustment Flow Chart

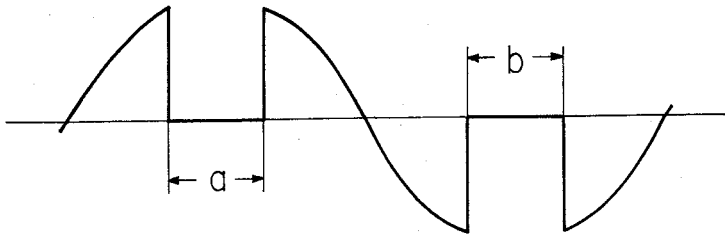

Fig. 4.1.4 S-Curve Waveform

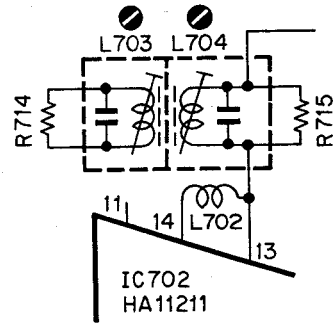

Fig. 4.1.5 DC Balance, Distortion (Mono)

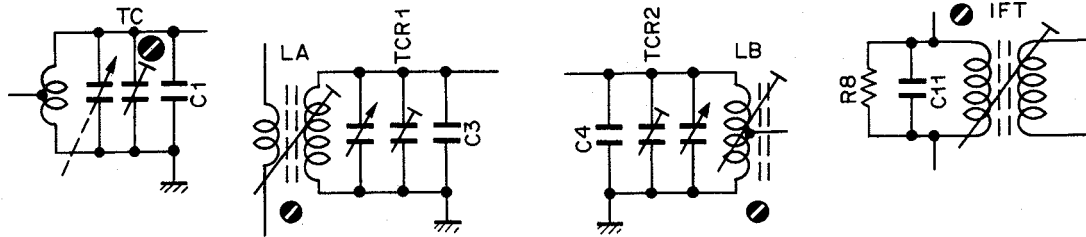

Fig. 4.1.6 Sensitivity of Front-end

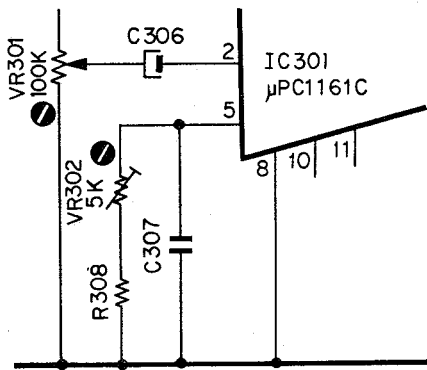

Fig. 4.1.7 Stereo Lamp and Recording Output Level

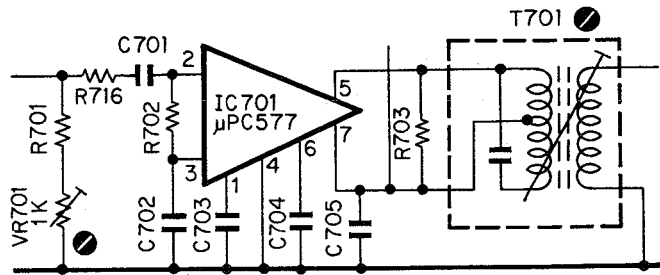

Fig. 4.1.8 Distortion of IF Block (Stereo)

STEP	ITEM	OUTPUT CONNECTION	MODE	ADJUSTMENT	REMARKS
1	Preliminary Steps for Adjustment		N-730 Initial Mode: Function — FM Dolby NR — OUT Hi-Blend — OFF Audio Mute — OFF ATT SW — 0dB		1. Connect the FM Generator to the 300-ohm Balanced Terminals of the N-730. 2. Set the frequency of the FM Generator to 98 MHz. (Refer to the preceding explanation for the frequency to be set.) 3. Set N-730 to the initial mode (see MODE). 4. Signal modulation is performed by adjusting the Signal Output VR of the M1700B Distortion Measurement System. The modulation rate is indicated by the meter on the M1000A FM Generator. 5. Test Point: TP-3 on the Main P.C.B. 6. Inhibit the AFC function by shorting between source and drain of FET Q701 on the IF P.C.B.
2	S-Curve Alignment	Oscilloscope to Test Point TP-3	FM Generator: Function — D.S. (Dual Sweep) Frequency — 98 MHz Sweep Width — 600 kHz RF Level — 1 mV (300 Ω) 65 dBf N-730: Mode — Mono		1. Select Station A by touching on the Station Memory Sensor A. 2. Turn the Station Preset Control A to obtain correct S-curve waveform (whose width "a" and "b" are equal) as shown in Fig. 4.1.4.
3	DC Balance Adjustment Distortion Adjustment (Mono)	Distortion Meter to RECORDING OUTPUT Jacks Oscilloscope between CN17-2 and CN17-4 of the IF P.C.B. Ass'y	FM Generator: Function — CW/Stereo RF Level — 1 mV (300 Ω) 65 dBf N-730: Mode — Mono	IF P.C.B. Quadrature Coils L703, L704	1. Do not turn the Frequency Dial on the FM Generator and Station Preset Control A of the N-730. 2. With Function Switch of the FM Generator set to CW, adjust L704 to obtain 0 V DC level (within ± 5 mV) on the Oscilloscope. 3. With Function Switch set to Stereo, adjust L703 to obtain minimum distortion.
4	Sensitivity Adjustment of Front-end	Oscilloscope and Distortion Meter to RECORDING OUTPUT Jacks	FM Generator: Function — Stereo Frequency — 98 MHz (See note.) RF Level — 2.2 μV (300 Ω) 12.0 dBf Input Selector — EXT. M1700B: OSC. — 1 kHz, Level 100% (Signal Modulation Rate: 100%) Switch Box: L + R N-730: Mode — Mono	Front-end Trimmer Capacitor TC Coils LA, LB, IFT (IF P.C.B. T701, VR701)	1. Adjust trimmer capacitor TC and coils LA, LB and IFT to obtain 3% or less distortion. 2. If a distortion of 3% or less is unable to be achieved, adjustment of coil T701 and semi-fixed volume VR701 will be necessary.
5	Stereo Lamp Adjustment		FM Generator: Function — Stereo Frequency — 98 MHz (See note.) RF Level — 1 mV (300 Ω) 65 dBf Pilot Level — 0 Input Selector — EXT. M1700B: OSC. — 1 kHz, Level 100% Switch Box: L + R N-730: Mode — Stereo	Main P.C.B. VR302	1. With the Pilot Test Switch on the FM Generator depressed, adjust the pilot level to obtain 80% (pilot signal modulation rate: 7.2%) on the meter of the FM Generator. 2. Adjust VR302 so that the Stereo Lamp will light up. As the lamp is illuminated in a certain range of VR, VR302 should be fixed approximately at the center of that range. 3. Touch on the Stereo Sensor and set to Mono mode, then make sure that the Stereo Lamp goes out.
6	Distortion Adjustment of IF Block (Stereo)	AC Voltmeter and Distortion Meter to RECORDING OUTPUT Jacks	FM Generator: Function — Stereo Frequency — 98 MHz (See note.) RF Level — 1 mV (300 Ω) 65 dBf Pilot Level — 100% (Pilot Signal Modulation Rate: 9%) Input Selector — EXT. M1700B: OSC. — 1 kHz, Level 100% Switch Box: L N-730: Mode — Stereo	IF P.C.B. T701, VR701 Front-end Coil IFT	Adjust T701, VR701 and IFT to obtain 0.15% or less distortion. IF the above value does not comply with the specified one, stricter readjustment starting from step 3 "DC Balance Adjustment and Distortion Adjustment (Mono)" is necessary.
7	Adjustment of Recording Output Level	AC Voltmeter to RECORDING OUTPUT Jacks	FM Frequency: Function — Stereo Frequency — 98 MHz RF Level — 1 mV (300 Ω) 65 dBf Pilot Level — 100% Input Selector — EXT. M1700B: OSC. — 400 Hz, Level 50% (Signal Modulation Rate: 50%) Switch Box: L/R N-730: Mode — Stereo	Main P.C.B. VR301	1. Set the Recording Output Level Control on the rear panel of the N-730 to the minimum position. 2. Adjust VR301 for the left channel with Switch Box "L" and for the right channel with Switch Box "R" to obtain 200 mV on the AC voltmeter.

Note: Do not turn the Frequency Dial on the FM Generator and Station Preset Control A of the N-730.

STEP	ITEM	OUTPUT CONNECTION	MODE	ADJUSTMENT	REMARKS
8	Separation Adjustment	AC Voltmeter and Oscilloscope to RECORDING OUTPUT Jacks	FM Generator: Function — Stereo Frequency — 98 MHz RF Level — 1 mV (300 Ω) 65 dBf Pilot Level — 100 % Input Selector — EXT. M1700B: OSC. — 1 kHz, Level 100% Switch Box: L/R N-730: Mode — Stereo	Main P.C.B. VR303	<ol style="list-style-type: none"> 1. Set the Switch Box to "L". 2. Adjust VR303 to obtain 50 dB or more difference of levels between right and left channels on the AC Voltmeter. 3. Set the Switch Box to "R", and make sure that the difference of levels is 50 dB or more.
9	Usable Sensitivity Measurement	Distortion Meter to RECORDING OUTPUT Jacks	FM Generator: Function — Stereo Frequency — 98 MHz Input Selector — EXT. M1700B: OSC. — 1 kHz, Level 100% Switch Box: L + R N-730: Mode — Mono		<ol style="list-style-type: none"> 1. Select Station A by touching on the Station Memory Sensor A. 2. Turn the Station Preset Control A to obtain minimum distortion. 3. Adjusting the RF level of the FM Generator, make sure that the RF level is 2.2 μV (300 Ω) or less when distortion reaches 3%. (At near 3% distortion, make a fine tuning of the N-730 to obtain minimum distortion.) If the above value does not comply with the specified one, stricter readjustment starting from step 2 "S-Curve Alignment" is necessary.
10	S-Curve Check	Oscilloscope to Test Point TP-3	FM Generator: Function — D.S. (Dual Sweep) Frequency — 98 MHz Sweep Width — 600 kHz RF Level — 1 mV (300 Ω) 65 dBf N-730: Mode — Mono		<ol style="list-style-type: none"> 1. Select Station A by touching on the Station Memory Sensor A. 2. Turn the Station Preset Control A to obtain correct S-curve waveform (whose width "a" and "b" are equal) as shown in Fig. 4.1.4. If the waveform is out of range, stricter readjustment starting from step 2 "S-Curve Alignment" will be necessary.
11	Performance Check				<ol style="list-style-type: none"> 1. Remove the shorting of FET Q701 on the IF P.C.B. to release the inhibition of AFC function. 2. Check the adjusted steps 2 — 10 as above, and be sure that each step is performed accurately. If satisfactory result is not obtained, stricter readjustment starting from step 1 will be required.
12	Dial Calibration			Front-end TCO, LO	<p>Receiving the station with its frequency already known or setting the FM Generator, turn the Station Preset Control A to that frequency after selecting the Station A by touching on the Station Memory Sensor A.</p> <p>Adjust TCO and LO so that the both Tuning Lamps (green) will light up. TCO: for higher frequency LO: for lower frequency</p>

Step 13. Dolby NR Circuit Adjustment

Refer to mounting diagram of Dolby NR P.C.B. Ass'y.

Equipment to be used:

Model 1700B Distortion Measurement System (from Sound Technology Inc.)

- (1) Supply + 10 V DC to Dolby NR P.C.B. terminal No. "1" and -10 V to "2". Short "3" and "7" to ground.
- (2) Connect "Signal Out" terminal of the Model 1700B to "6", and AC voltmeter of the Model 1700B to "5".

Apply 5 kHz signals to "6", and adjust the signal output level of the Model 1700B so that the voltage at "5" may read 59 mV.

- (3) After shorting "4" and "5", adjust VR301 so that the "5" drops by 8 ± 0.25 dB in the voltage.
- (4) Without changing the signal output level, apply 5 kHz signals to "8" and check that the voltage at "9" is 59 mV.
- (5) Short "9" and "10", and make sure that the "9" drops by 8 ± 0.25 dB in the voltage.

Note: Dolby NR P.C.B. Ass'y is an optional accessory to be ordered separately except for the U.S.A. version.

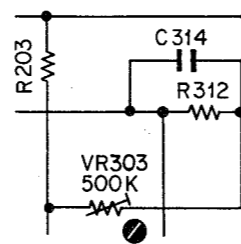

Fig. 4.1.9 Separation

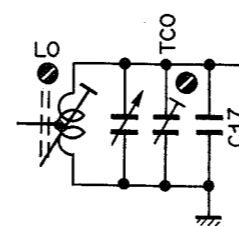

Fig. 4.1.10 Dial Calibration

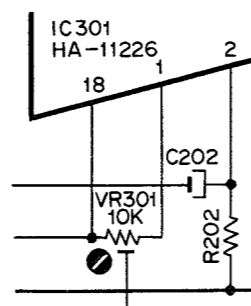

Fig. 4.1.11 Dolby NR Circuit

4.1.2. Auto-Return Scale Calibration

- (1) Remove FM Generator from the FM Antenna Terminals of the N-730.
- (2) Touch on the Station Memory Sensor A at any mode of the N-730. (Lamp A will light.)
- (3) Turn counterclockwise the knob of the Station Preset Control A until it stops (click sound can be heard).
- (4) Adjust the VR303 on the Preset P.C.B. Ass'y till the Tuning Pointer (orange lamp) indicates 87.5 MHz (75.5 MHz in Japan) at the condition of above step 3.
- (5) Touch on the Station Memory Sensor D.
- (6) Turn clockwise the knob of the Station Preset Control D until it stops.
- (7) Adjust the VR301 on the Preset P.C.B. Ass'y till the Tuning Pointer indicates 108 MHz (90 MHz in Japan).
- (8) Repeat steps from 2 three times (or more) as the limitation of one end will be slightly changed when other end is calibrated.

4.1.3. Auto-Tuning Calibration

- (1) Connect the FM Generator to the 300-ohm FM Antenna Terminals of the N-730. Then set to the following modes:

FM Generator: Frequency — 98 MHz (83 MHz in Japan)
 Function — CW
 RF Level — $55 \mu\text{V}$ (300Ω) 40 dBf

N-730: Threshold Control — Min.

- (2) Turn the VR302 on the Preset P.C.B. Ass'y fully counterclockwise. Adjust VR302 clockwise till the Tuning Pointer (orange lamp) stops, showing the frequency set by the FM Generator (98 MHz).

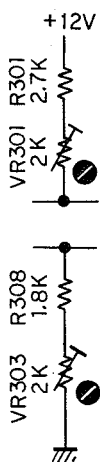

Fig. 4.1.12

Auto-Return Scale Calibration

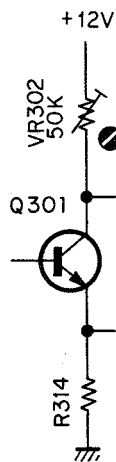

Fig. 4.1.13

Auto-Tuning Calibration

4.2. Preamplifier Section

4.2.1. Preamplifier Eq. Adjustment

Refer to Fig. 4.1.2, Diagram for Adjustment.

- (1) Short Phono Input Jacks with shorting plugs (whose positive and negative sides are shorted).
- (2) Connect a DC Voltmeter to Test Point TP-1, and adjust VR101 to obtain -0.5 V (to -1 V) on the DC Voltmeter.
- (3) Connect a DC Voltmeter to Test Point TP-2, and adjust VR201 to obtain -0.5 V (to -1 V) on the DC Voltmeter.

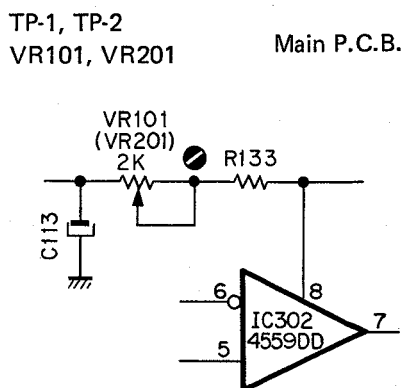

Fig. 4.2.1 Preamp. Eq. Adjustment

4.2.2. Signal-to-Noise Ratio Measurement

- (1) Phono Input / Recording Output

Mode:

Function — Phono

Tape Monitor — Source

Recording Output Level Control — Min.

Measurement:

Short Phono Input Jacks with shorting plugs (whose positive and negative sides are shorted). Connect an AC Voltmeter to Tape Recording Jacks and measure the level through IHF A Network.

Reference Tape Recording Output Level:

100 mV (0 dB)

- (2) Aux. Input / Preamp. Output

Mode:

Function — Aux.

Tape Monitor — Source

Tone Controls (Bass, Treble) — Center Position

Balance Control — Center Position

Level Preset Control — Center Position

Volume Scale — Max. Position

Measurement:

Short Aux. Input Jacks with shorting plugs. Connect an AC Voltmeter to Preamplifier Output Jacks and measure the level through IHF A Network.

Reference Preamplifier Output Level : 1 V (0 dB)

4.2.3. Distortion Measurement

(1) Phono Input / Recording Output

Mode:

- Function — Phono
- Tape Monitor — Source
- Recording Output Level Control — Min.

Measurement:

Connect an AC Voltmeter and a distortion meter to the Tape Recording Output Jacks.

Feed in 1 kHz to Phono Input Jacks and adjust the input level (oscillator output level) to obtain 2 V on the AC Voltmeter, then measure the distortion.

(2) Aux. Input/Preamp. Output

Mode:

- Function — Aux.
- Tape Monitor — Source
- Tone Controls (Bass, Treble) — Center Position
- Balance Control — Center Position
- Level Preset Control — Center Position
- Volume Scale — Max. Position

Measurement:

Connect an AC Voltmeter and a distortion meter to the Preamplifier Output Jacks.

Feed in 1 kHz to Aux. Input Jacks and adjust the input level to obtain 2 V on the AC Voltmeter, then measure the distortion.

4.3. Power Amplifier Section

4.3.1. Idling Current Adjustment

- (1) Connect a DC Mili-voltmeter across R032, R033 on the Power Amp. P.C.B. as shown in Fig. 4.3.1.
- (2) Connect an 8-ohm 110 watts or more wattage load resistor and a distortion meter to the Speaker Terminal.
- (3) Adjust VR001 on the Power Amp. P.C.B. to obtain about 10 mV on the DC Mili-voltmeter. (Adjustment should be made for each channel.)
- (4) Connect an Oscillator to the Main Amplifier Input Jacks.
- (5) Check to insure whether the distortions at 1 kHz and 10 kHz satisfy the following specifications (output wattage should be 105 watts in each frequency):

1 kHz & 10 kHz : 0.007 % or less

Note:

As long as all parts meet the specifications, the published characteristics can be obtained without readjustment.

Generally, no adjustment is required if only defective parts are replaced at repair. Observe the following precautions when repairing defective parts:

- (1) Relocation a wiring can cause larger distortion. Do not relocate the wiring.
- (2) Fully tighten or retighten the wrapping wires to decrease the resistance between wires and terminals.
- (3) If a new semiconductor is installed in the Power Block Ass'y, a perfect balance should be held between it and the existing semiconductors in the block. An imperfect balance can cause larger distortion or unwanted oscillation. To maintain a good balance, connect an 8-ohm 110 watts load resistor to the speaker terminal, then measure the distortion and check that it meets the above "Idling Current Adjustment" (in this case, the residual distortion factor of the instrument should be lower than the specified value).
- (4) Incorrect idling current will increase the distortion. Usually, the idling current of power transistors Q014 and Q015 on the Power Block Ass'y is about 10 mA.
- (5) Improper locations of power supply wiring will increase the distortion at 105 watts output.

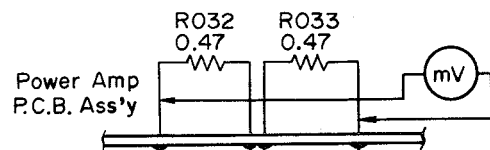

Fig. 4.3.1

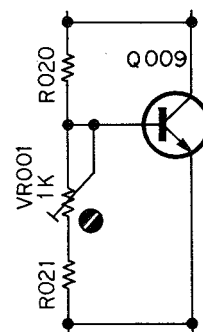

Fig. 4.3.2 Idling Current Adjustment

5. THREADING

5.1. Dial Threading

5.1.1. How to prepare Dial Thread

Refer to Fig. 5.1.1.

At an end of the thread, make a ring of about 3.4 mm ID and fix a thread guide in the ring.

The length of the thread between the thread guide at one end and the other should be about 1,550 mm. After rounding off the thread guide with pliers, adhere the guide and ring with AVDEL BOND #C2.

Thread: Hamilton Super 505 (Wadding: Aramid (Kevlar);
Braid: Nylon Rope) with a length of 1,550 mm.

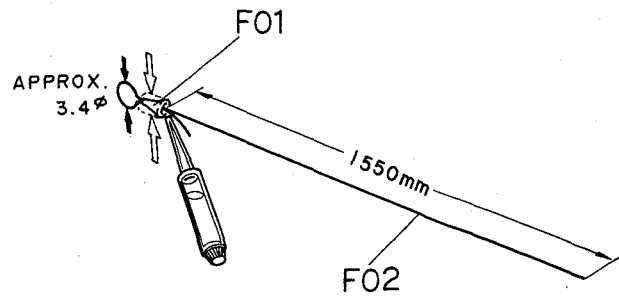

Fig. 5.1.1

5.1.2. How to fit Front-end Reel Ass'y

Refer to Fig. 5.1.2.

- (1) Fully turn the shaft at the Front-end clockwise.
- (2) Loosen L01 (screws) then mount O1 (Timing Belt) to O2 (Front-end Reel Ass'y).
- (3) Insert Front-end Reel Ass'y into the shaft at the Front-end.
- (4) Set the gap between Front-end Reel Ass'y and the stopper part of the Front-end to be about 0.5 mm. Refer to Fig. 5.1.3.
- (5) Refer to Fig. 5.1.2. Keep Rib C to be perpendicular to chassis, then fix the Front-end Reel Ass'y with L02 (screws).
- (6) Adjust the position of the Motor Base Ass'y (Front-end) to obtain the following belt tension, then fix it with L01 (screws) :

Belt moves approximately for 3 – 5 mm to dotted line when pushed lightly with fingers but returns when released. Refer to Fig. 5.1.4.

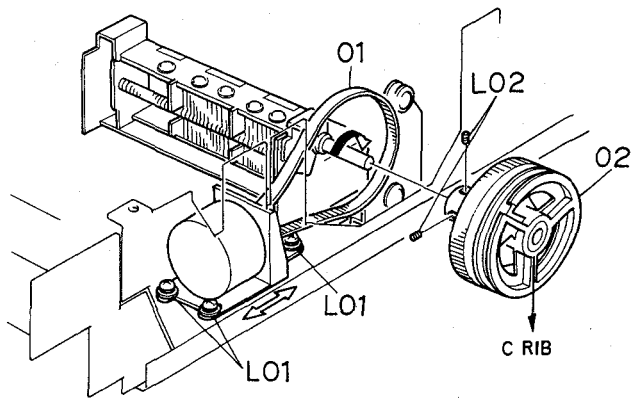

Fig. 5.1.2

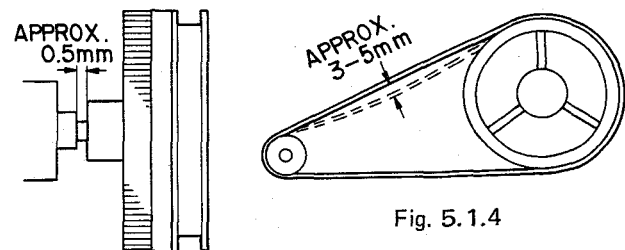

Fig. 5.1.4

Fig. 5.1.3

5.1.3. How to set Dial Threading

- (1) Referring to Fig. 5.1.5, set a dial thread to a protrusion "A" by way of "C".
- (2) Referring to Fig. 5.1.6, set the dial thread by way of F02 to F06 (pulleys) in that order, and wind the thread 2 turns on F01 (Front-end Reel Ass'y).
- (3) Referring to Fig. 5.1.7, put the dial thread end (free end) on F05 (thread guide) and fix it with F06 (Pulley Spring).
- (4) Referring to Fig. 5.1.8, hook that Pulley Spring in the protrusion "B". Pull the dial thread so that a space of 5 – 6 mm can be obtained between the protrusion "D" and the thread guide.

After crushing the thread guide with pliers, fix it by applying AVDEL BOND #C2.

Note: AVDEL BOND #C2 should be applied to strengthen adherence of the thread to the guide. Care should be taken while bonding not to apply excessive adhesive to any other part.

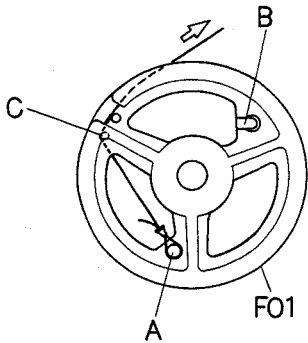

Fig. 5.1.5

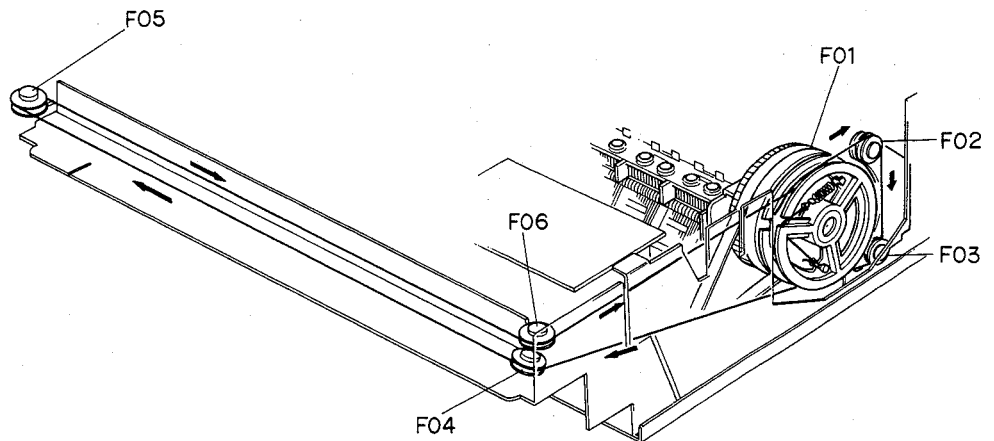

Fig. 5.1.6

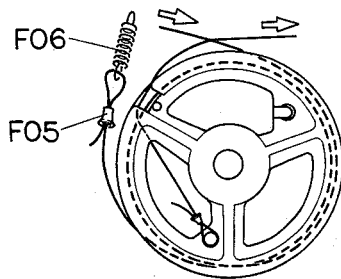

Fig. 5.1.7

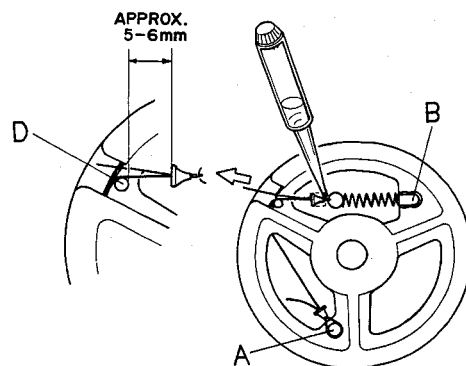

Fig. 5.1.8

5.1.4. How to assemble Lamp Base Ass'y with Dial Thread

- (1) Move F01 (Wire Stopper) backward with pliers (refer to Fig. 5.1.10).
- (2) Referring to Fig. 5.1.9, set a dial thread into the groove on the protrusions "B" and "B'" of the F03 (Lamp Base Ass'y).
- (3) Referring to Fig. 5.1.10, set F03 (Lamp Base Ass'y) to the left end, and position F03 so that the right edge corresponds to the groove on the F04 (Guide Plate).
- (4) Move F01 (Wire Stopper) forward with pliers.

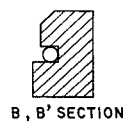

Fig. 5.1.9

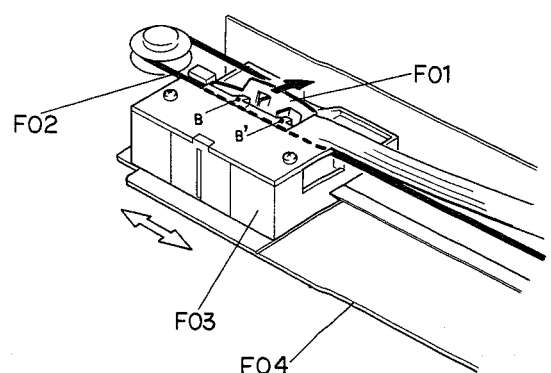

Fig. 5.1.10

5.2. Volume Controller Threading

5.2.1. How to prepare Volume Controller Thread

- (1) Refer to Figs. 5.2.1 and 5.2.2. Make knots at the ends of Thread A (OJ04005A) and Thread B (OJ04006A) and bond them with AVDEL BOND #C2.

Thread: Hamilon Super 414 (Wadding: Aramid fiber, Braid: Polyester) with a length of 400 mm and 330 mm.

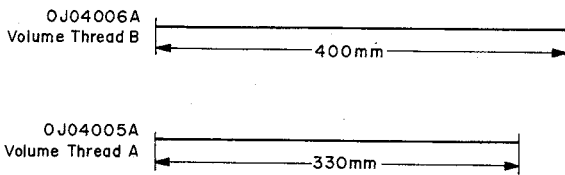

Fig. 5.2.1

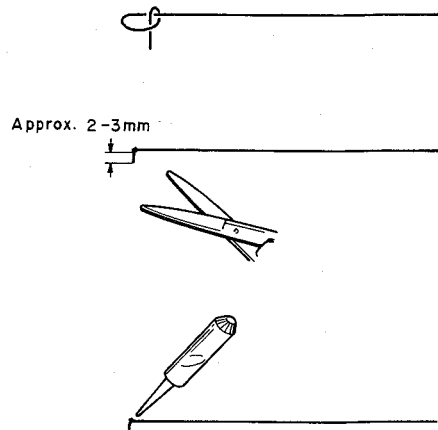

Fig. 5.2.2

5.2.2. How to set Volume Controller Threading

- (1) Remove the Front Panel Ass'y, referring to item 3.3, removal of Front Panel Ass'y.
- (2) Remove the Volume Control Ass'y, referring to item 3.10.
- (3) Remove F01 and F02 shown in Fig. 5.2.3, and detach the Motor Base Ass'y (Volume) F03.
- (4) Referring to Fig. 5.2.3, turn the Volume Clutch manually in direction A until it stops.
- (5) Refer to Figs. 5.2.4 and 5.2.5. Insert the knot of Thread B in the notch of the Volume Clutch, wind the thread twice around it, and fix it temporarily with scotch tape, etc. so as not to make it loose.
- (6) Refer to Fig. 5.2.6. Remove an E-ring and a washer from the Mylar Mask Ass'y and detach Pulley LV. Insert the knot on Thread A into the notch of Pulley LV, and mount Pulley LV onto the shaft.

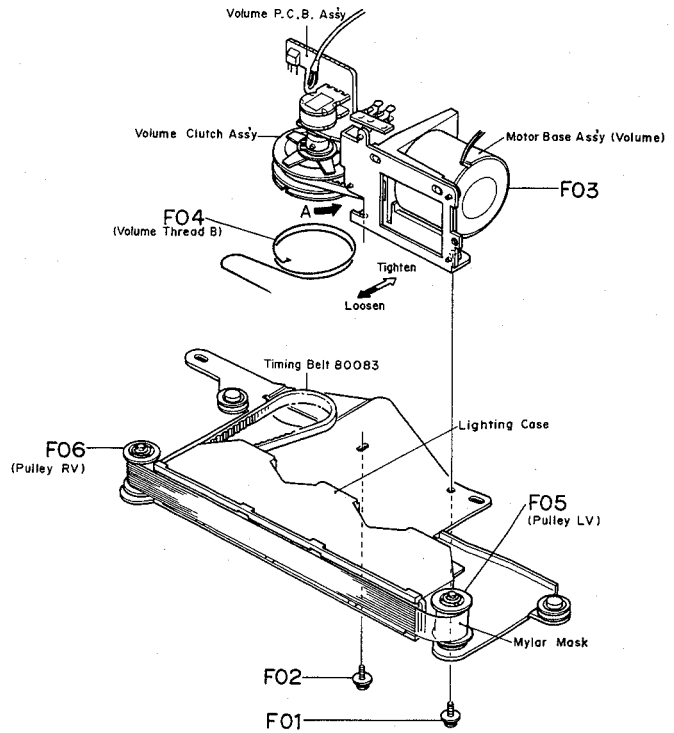

Fig. 5.2.3

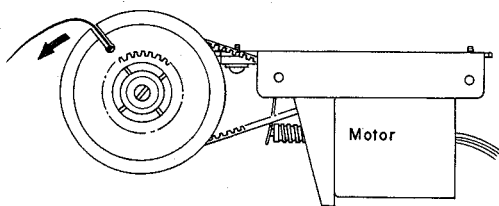

Fig. 5.2.4

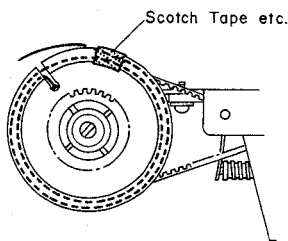

Fig. 5.2.5

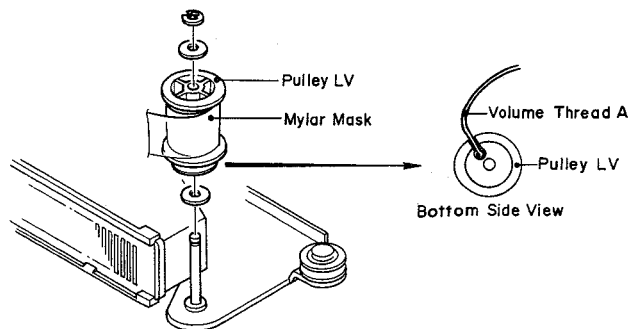

Fig. 5.2.6

- (7) Refer to Figs. 5.2.7 and 5.2.8. Manually turn Pulley LV to set the end of the masking of Mylar Mask within approx. 1 mm from the end of the Scale Filter of the Lighting Case. Then fix Pulley RV and Thread A temporarily with scotch tape, etc. as shown in Fig. 5.2.8. Thread A should be wound around the Pulley LV for 1/2 to 1 turn.
- (8) Refer to Figs. 5.2.3 and 5.2.9. Loop the Timing Belt 80083 around the Volume Clutch of the Motor Base Ass'y (Volume), and assemble it with Volume Control Base Ass'y by screws F01 and F02. Readjust it if the position of the Mylar Mask mentioned in (7) slips resulting from incomplete contact between Timing Belt 80083 and Volume Clutch. Adjust the tension of the Timing Belt 80083 by loosening F01 and F02 of Fig. 5.2.3. And make sure that the tension is such that it can be depressed by 3 – 5 mm when it is lightly pushed with the finger as shown in Fig. 5.2.9.
- (9) Refer to Figs. 5.2.9 and 5.2.10. Adjust the tension of the Timing Belt 80071 between the Volume Clutch and the Motor Gear, so that it is depressed by 3 – 5 mm when it is lightly pushed with the finger as shown in Fig. 5.2.9. Adjust the tension of this belt by loosening 3 screws F01 in Fig. 5.2.10.

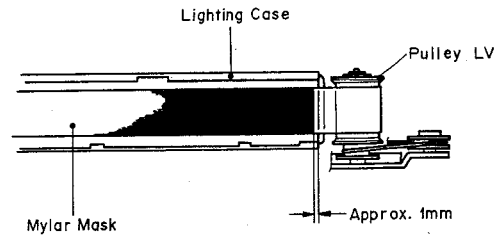

Fig. 5.2.7

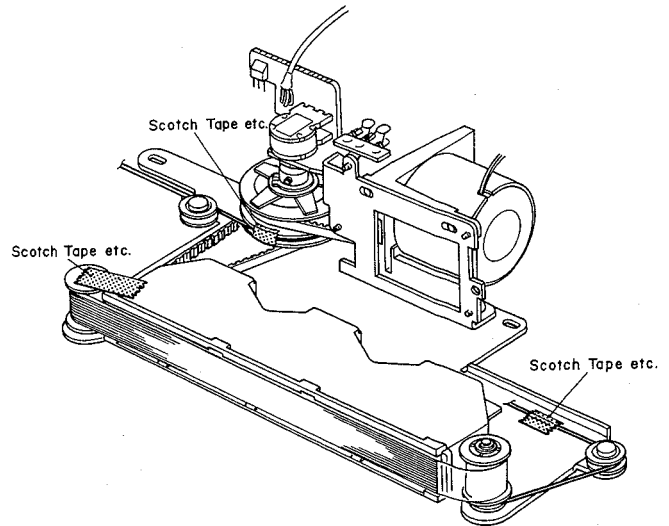

Fig. 5.2.8

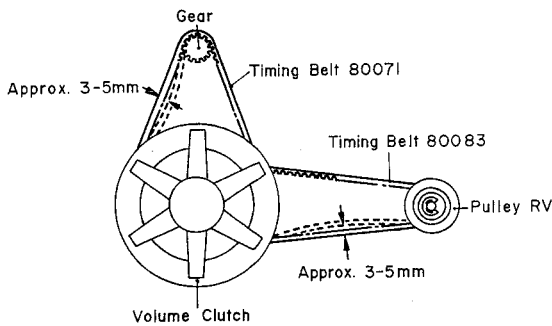

Fig. 5.2.9

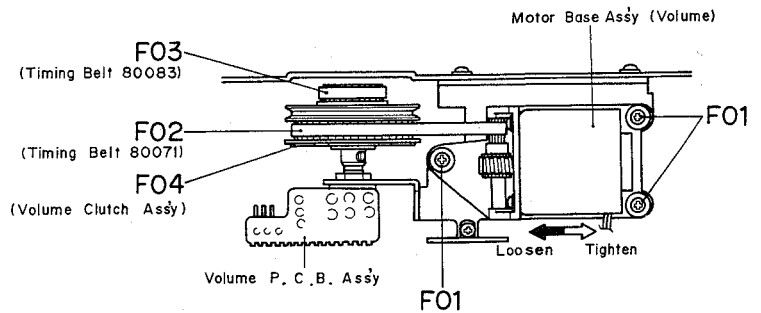

Fig. 5.2.10

- (10) Refer to Figs. 5.2.11 and 5.2.12. Remove scotch tape which has been temporarily attached to Volume Clutch for fixing Thread B. Pass Thread B round Pulley F01. Then by rounding off with pliers, fix the Thread Guide F02 at the end of the thread so that the end of the thread comes 25 – 30 mm from the Pulley F01. Tie the thread, cut the end 2 – 3 mm from the knot, and bond the knot with AVDEL BOND #C2 as shown in Fig. 5.2.12.
- Mount Spring LV F04 to Thread B. Remove the tape which was used to fix Thread A, then mount Thread A to Spring LV F04 through Thread Guide F03. By rounding off with pliers, fix Thread Guide F03 so that the spring elongates to about 16 mm as shown in Fig. 5.2.11. Tie the thread, cut the end 2 – 3 mm from the knot, and bond the knot with AVDEL BOND #C2.
- (11) Remove the temporarily fixing tape which was used to fix the Pulley RV, then connect the connector

CN-27 and turn the Power of the N-730 ON, and start the Volume Motor with the Volume Control Sensor. Make sure that the Thread Guides assembled with Threads will not touch the Pulley.

Check for abnormality in the movement of Timing Belts and Mylar Mask, and occurrence of abnormal noise, etc.

- (12) Turn the Power of the N-730 OFF, and assemble the Volume Control Ass'y with its 3 screws and washers.
- (13) Mount the Front Panel Ass'y.
- (14) Turn the Power of the N-730 ON and calibrate the Volume Scale according to item 5.2.3. At the same time, check to insure freedom from abnormal noise and abnormal operation.

Notes: 1. Do not apply AVDEL BOND #C2 to threads excessively.

2. After completion of adjustment, lock the adjustment screws with lock tight paint.

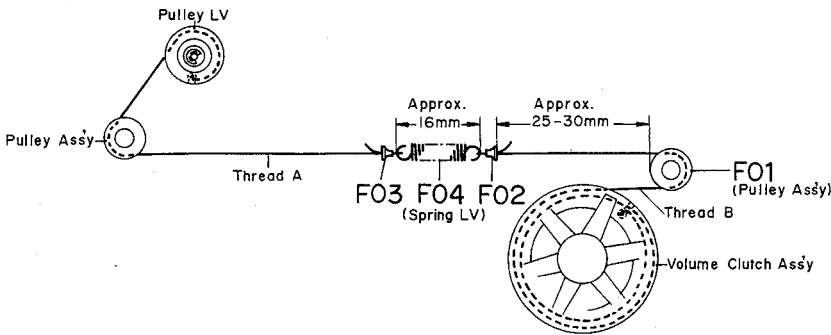

Fig. 5.2.11

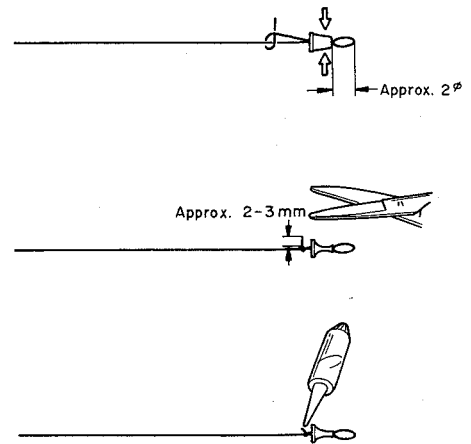

Fig. 5.2.12

5.2.3. Volume Scale Calibration

- (1) Set the volume to the minimum position by volume Preset Control.
- (2) Refer to Fig. 5.2.13.
With pushing toward the front panel side, adjust the position of Volume Control Base Ass'y in either right or left direction so that the Mylar Mask (which shows the volume level) indicates position 0. Then fasten screws.
- (3) Set the volume to the maximum position and check to insure that the volume level shows position 10.

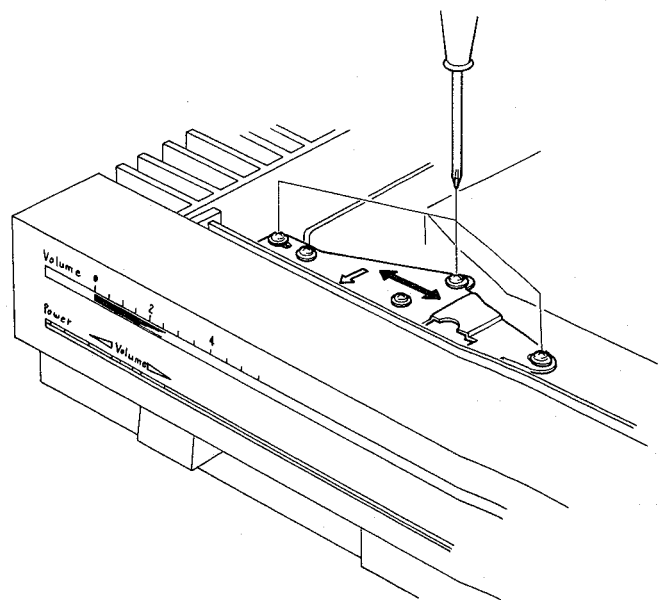

Fig. 5.2.13

6. MOUNTING DIAGRAMS AND PARTS LIST

Schematic Ref. No.	Part No.	Description	Schematic Ref. No.	Part No.	Description
	BA04030A	Main P.C.B. Ass'y	R216,217 218,231 301	OB05591A	Carbon Resistor 15K ERD-25V J
	OB07753D	Main P.C.B.			
IC301	OB06153A	IC μ PC1161C	R119,219	OB05650A	Carbon Resistor 12K ERD-25V J
IC302	OB06205A	IC RC4559DD	R120,125	OB05558A	Carbon Resistor 100 ERD-25V J
IC303,307	OB06146A	IC RC4558DD	220,225		
IC304,305 306	OB06169A	IC TC4066BP	R121,221	OB05505A	Carbon Resistor 1.5K ERD-25V J
Q101,102 201,202	OB01872A	Transistor 2SC945(L)	R122,222	OB01885A	Carbon Resistor 39K ERD-25V J
Q103,104 105,203 204,205	OB06071A	Transistor 2SC945(L)(1)	R124,136 137,138 224,236 237,238 337	OB05568A	Carbon Resistor 120K ERD-25V J
Q106,107 109,206 207,209	OB06070A	Transistor 2SC1636	R126,226 311	OB01781A	Carbon Resistor 1K ERD-25V J
Q108,208 304,308	OB06013A	Transistor 2SA733	R128,228	OB09122A	Metal Film Resistor 51 ERO-25CK
Q301,302 306,309 310,311	OB06100A	Transistor 2SC945A	R129,135 229,235 309,353 354,357 372,375	OB01920A	Carbon Resistor 100K ERD-25V J
Q303	OB01600A	FET 2SK30A(Y)	R130,230	OB01588A	Metal Film Resistor 27K ERO-25VK G
D101-105 201-205 301-312 315-336	OB01909A	Silicon Diode 1S1555 (44 pcs.)	R132,232 R134,234 R139,140 141,142 151,157	OB09101A	Metal Film Resistor 2.2K ERO-25VK G
D313,314	OB01702A	Varistor KB269	239,240	OB05649A	Carbon Resistor 150 ERD-25V J
ZD301,302 303,304	OB06167A	Zener Diode 6.2V RD6.2EB	241,242 251,257	OB05562A	Carbon Resistor 47K ERD-25V J
LF301	OB08295C	LPF BL-5	R146,148	OB05672A	Carbon Resistor 2.2M ERD-25V J
VR101,201	OB09106A	Semi-fixed Volume 2K	149,152		
VR301	OB03832A	Semi-fixed Volume 100K	153,246		
VR302	OB03831A	Semi-fixed Volume 5K	248,249		
VR303	OB09107A	Semi-fixed Volume 500K	252,253		
R101,145 150,201 245,250 349 364-371	OB05596A	Carbon Resistor 220K ERD-25V J (15 pcs.)	322,351 377 R147,247 R154,155	OB05895A	Metal Film Resistor 10K ERO-25VK G
R102,202	OB05563A	Carbon Resistor 56K ERD-25V J	254,255	OB09100A	Metal Film Resistor 1K ERO-25VK G
R103,113 203,213	OB05661A	Carbon Resistor 22K ERD-25V J	R156,256 R302,303	OB01679A	Carbon Resistor 100 ERD-25T J
R104,127 133,204 227,233 304,306 344,362 363	OB01833A	Carbon Resistor 10K ERD-25V J	310,327 328,330 335,336 341,352 355,356 358,359 360,361	OB05564A	Carbon Resistor 1M ERD-25V J
R105,205	OB01795A	Carbon Resistor 4.7K ERD-25V J	R308	OB09102A	Metal Film Resistor 15K ERO-25VK G
R106,206	OB01830A	Carbon Resistor 1.8K ERD-25V J	R312	OB01902A	Carbon Resistor 68K ERD-25V J
R107,207	OB05664A	Carbon Resistor 3.9K ERD-25V J	R313	OB05587A	Carbon Resistor 56 ERD-25V J
R108,112 208,212 338	OB05700A	Carbon Resistor 470K ERD-25V J	R314,315 R316,317	OB05503A	Carbon Resistor 82 ERD-25V J
R109,209 348	OB01564A	Carbon Resistor 82K ERD-25V J	R318,319 R324,325 332,334	OB05956A	Fail Safe Type Resistor 2.7 ERD-14F J
R110,210 350	OB05674A	Carbon Resistor 820K ERD-25V J	R329,376	OB05608A	Carbon Resistor 220 ERD-25V J
R111,123 211,223	OB05665A	Carbon Resistor 560K ERD-25V J	R339,340 R343	OB05601A	Carbon Resistor 1.5M ERD-25V J
R114,143 144,214 243,244	OB01793A	Carbon Resistor 3.3K ERD-25V J	R373,374 R378	OB05673A	Carbon Resistor 5.6K ERD-25V J
R115,215	OB05566A	Carbon Resistor 2.2K ERD-25V J	C101,201	OB05941A	Fail Safe Type Resistor 1 ERD-14F J
R116,117 118,131	OB05591A	Carbon Resistor 15K ERD-25V J	C102,108 119,121 122,123	OB09113A	Fail Safe Type Resistor 4.7 ERD-14F J
				OB09112A	Fail Safe Type Resistor 3.3 ERD-14F J
				OB05593A	Carbon Resistor 150K ERD-25V J
				OB05788A	S.P. Capacitor 560P 50V J
				OB01412A	Electrolytic Capacitor 10 μ 16V

Schematic Ref. No.	Part No.	Description
C202,208	OB01412A	Electrolytic Capacitor 10μ 16V
219,221		
222,223		
C103,203	OB01389A	Electrolytic Capacitor 4.7μ 16V
C104,117	OB05660A	Mylar Capacitor 0.039μ 50V J
204,217		
C105,125	OB01716A	Ceramic Capacitor 470P 50V
205,225		
313		
C106,107	OB05813A	Mylar Capacitor 0.056μ 50V J
206,207		
C109,209	OB05653A	Mylar Capacitor 1500P 50V J
C110,210	OB05599A	Ceramic Capacitor 150P 50V
C111,211	OB05853A	Electrolytic Capacitor 22μ 16V M(MS)
C112,212	OB01289A	Ceramic Capacitor 220P 50V
C113,213	OB05885A	Electrolytic Capacitor 100μ 10V
C114,214	OB05884A	Electrolytic Capacitor 470μ 10V
C115,215	OB05909A	Mylar Capacitor 0.12μ 50V J
C116,216	OB05832A	Mylar Capacitor 0.018μ 50V J
C118,218	OB05681A	Mylar Capacitor 0.01μ 50V J
C120,220	OB09108A	Ceramic Capacitor 22P 50V
C124,224	OB01836A	Electrolytic Capacitor 47μ 10V
C126,226	OB09127A	Mylar Capacitor 3300P 50V K
C301	OB01288A	Ceramic Capacitor 100P 50V
C302	OT04025A	Ceramic Capacitor 1000P 50V
C303,324	OB01290A	Ceramic Capacitor 0.01μ 50V
325,331		
332,333		
334,335		
336		
C304	OT04026A	Ceramic Capacitor 330P 50V
C305	OB01502A	Electrolytic Capacitor 330μ 16V
C306	OB05819A	Electrolytic Capacitor 4.7μ 16V M(MS)
C307	OB09098A	S.P. Capacitor 470P 50V J
C308,342	OB09091A	Ceramic Capacitor 0.01μ 25V
C309	OB09111A	Electrolytic Capacitor 3.3μ 16V M(MS)
C310	OB09110A	Electrolytic Capacitor 1.5μ 16V M(MS)
C311	OB09109A	Electrolytic Capacitor 0.22μ 16V M(MS)
C312,318	OB05796A	Mylar Capacitor 0.047μ 50V J
319,322		
323		
C314	OT04027A	Ceramic Capacitor 680P 50V
C315,337	OB01398A	Electrolytic Capacitor 220μ 16V
C316,317	OB01862A	Electrolytic Capacitor 22μ 16V
330		
C320,321	OB01802A	Mylar Capacitor 2200P 50V J
C326,327	OB01400A	Electrolytic Capacitor 100μ 16V
C328,329	OB01392A	Electrolytic Capacitor 470μ 16V
C338,339	OB05781A	Tantalum Capacitor 0.1μ 35V
344		
C340	OB05772A	Tantalum Capacitor 0.22μ 35V
C341	OB01405A	Electrolytic Capacitor 1μ 16V
C343	OB05953A	Ceramic Capacitor 0.022μ 25V
RL301,302	OB07171A	HB Relay DC24V
SW301	OB07029A	Slide Switch
TP1,2,3	OB03924A	Gate Pin
CN1	BA03807A	10P Connector Ass'y
CN2,3,16	OB08334A	8P-T Post
CN4,5,6	OB08182A	6P-T Post
CN7,8	OB08183A	5P-T Post
CN9,10	OB08236A	4P-T Post
CN11-15	OB08185A	3P-T Post (5 pcs.)
CN20	OB08489A	7P-H Connector Ass'y D101A
	OE00166A	Screw M2 x 4 Cylinder Head (2 pcs.)

Note: Mounting diagram shows a dip side view of the printed circuit board.
6.1. Main P.C.B. Ass'y

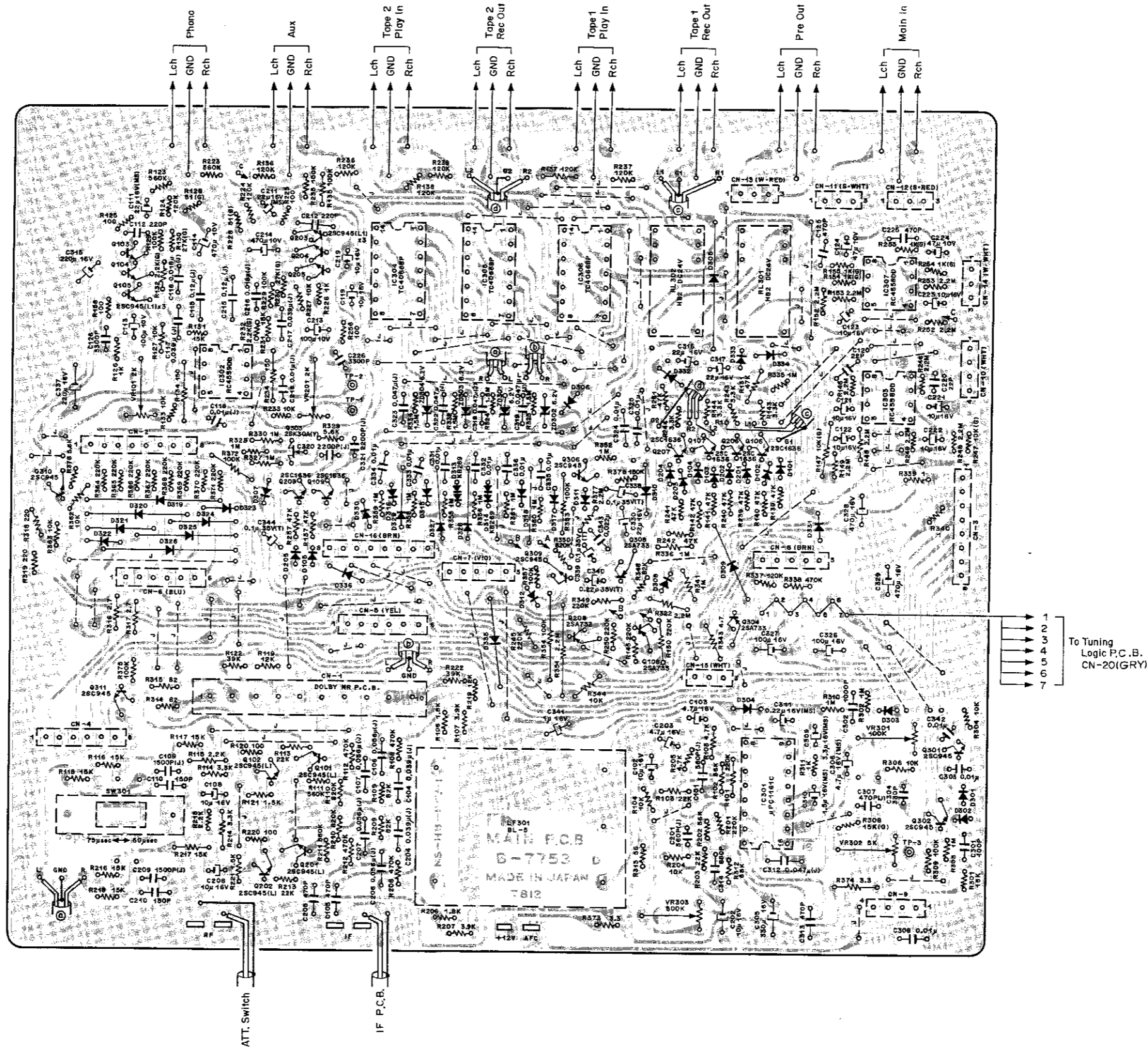

Note: Diode is 1S1555 unless otherwise specified.

Fig. 6.1

6.2. IF P.C.B. Ass'y

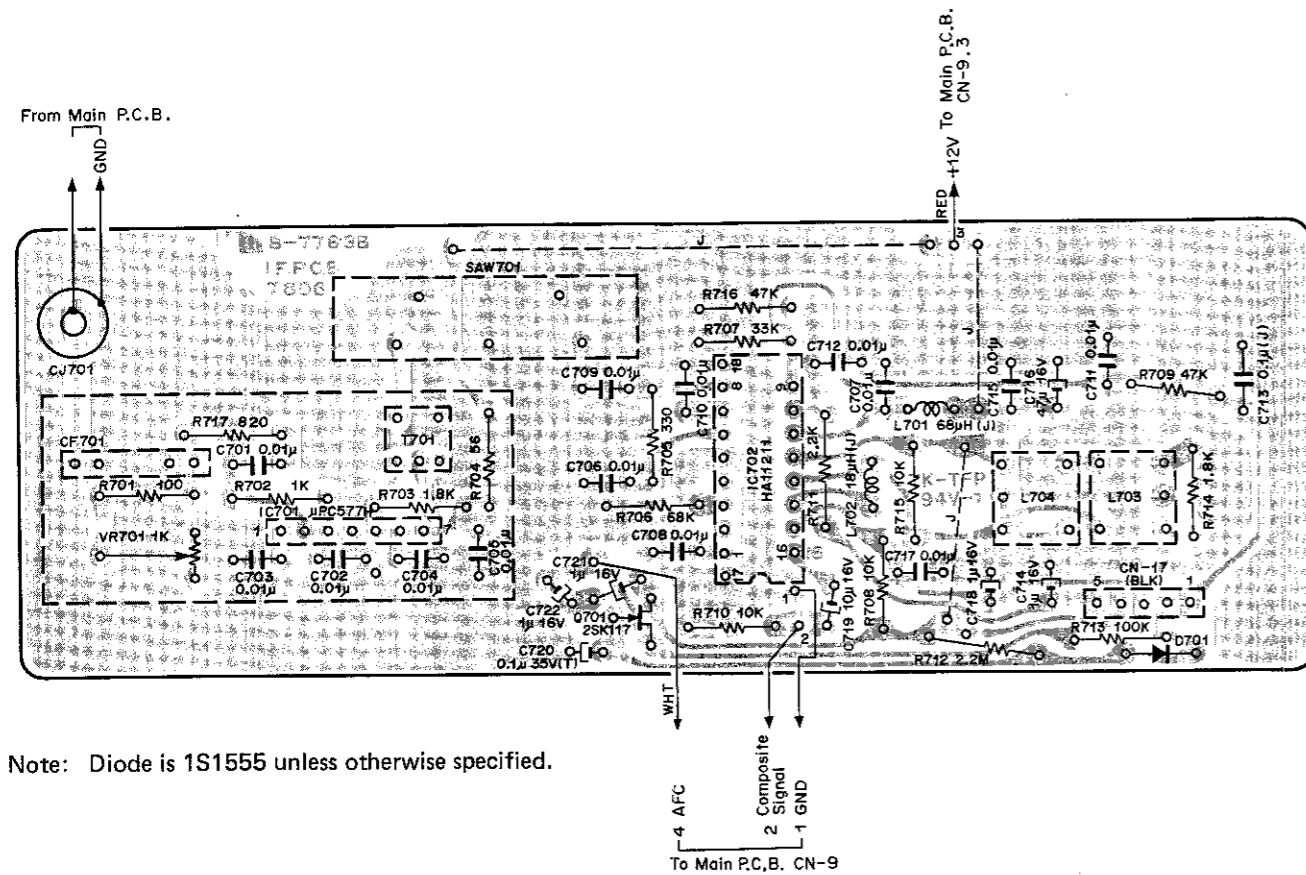

Fig. 6.2

Note: Diode is 1S1555 unless otherwise specified.

Schematic Ref. No.	Part No.	Description	Schematic Ref. No.	Part No.	Description
	BA03930B	IF P.C.B. Ass'y	R709,716	OB05641A	Carbon Resistor 47K ERD-25T J
IC701	OB07763B	IF P.C.B.	R711	OB05622A	Carbon Resistor 2.2K ERD-25T J
IC702	OB06114A	IC μ PC577H	R712	OB05671A	Carbon Resistor 2.2M ERD-25T J
Q701	OB06129A	FET 2SK117	R713	OB01889A	Carbon Resistor 100K ERD-25T J
D701	OB01909A	Silicon Diode 1S1555	R717	OB01680A	Carbon Resistor 820 ERD-25T J
T701	OB08464A	IF Coil	C701-712	OB01290A	Ceramic Capacitor 0.01 μ 50V
L701	OB06561A	Inductor 68 μ H J	C713	OB01780A	Mylar Capacitor 0.1 μ 50V J
L702	OB06582A	Inductor 18 μ H J	C714,718	OB01405A	Electrolytic Capacitor 1 μ 16V
L703	OB06580A	Quadrature Coil A-1	C716	OB01403A	Electrolytic Capacitor 47 μ 16V
L704	OB06581A	Quadrature Coil A-2	C719	OB01412A	Electrolytic Capacitor 10 μ 16V
SAW701	OB08463A	SAW Filter	C720	OB05781A	Tantalum Capacitor 0.1 μ 35V
CF701	OB08341A	Ceramic Filter SFJ10.7 MA-A	CJ701	OB08384A	1P Pin Jack
VR701	OB07178A	Semi-fixed Volume 1K	CN9	OB08477A	4P-H Connector Ass'y D101
R701	OB01679A	Carbon Resistor 100 ERD-25T J	CN17	OB08183A	5P-T Post
R702	OB01857A	Carbon Resistor 1K ERD-25T J		QJ03872A	Shield Case D1 (1 pce.)
R703,714	OB05614A	Carbon Resistor 1.8K ERD-25T J		QJ03873A	Shield Plate A D1 (1 pce.)
R704	OB05890A	Carbon Resistor 56 ERD-25T J		QJ03874A	Shield Plate B D1 (1 pce.)
R705	OB05577A	Carbon Resistor 330 ERD-25T J			
R706	OB05692A	Carbon Resistor 68K ERD-25T J			
R707	OB05509A	Carbon Resistor 33K ERD-25T J			
R708,710	OB01888A	Carbon Resistor 10K ERD-25T J			
715					

6.3. Dolby NR P.C.B. Ass'y (Optional)

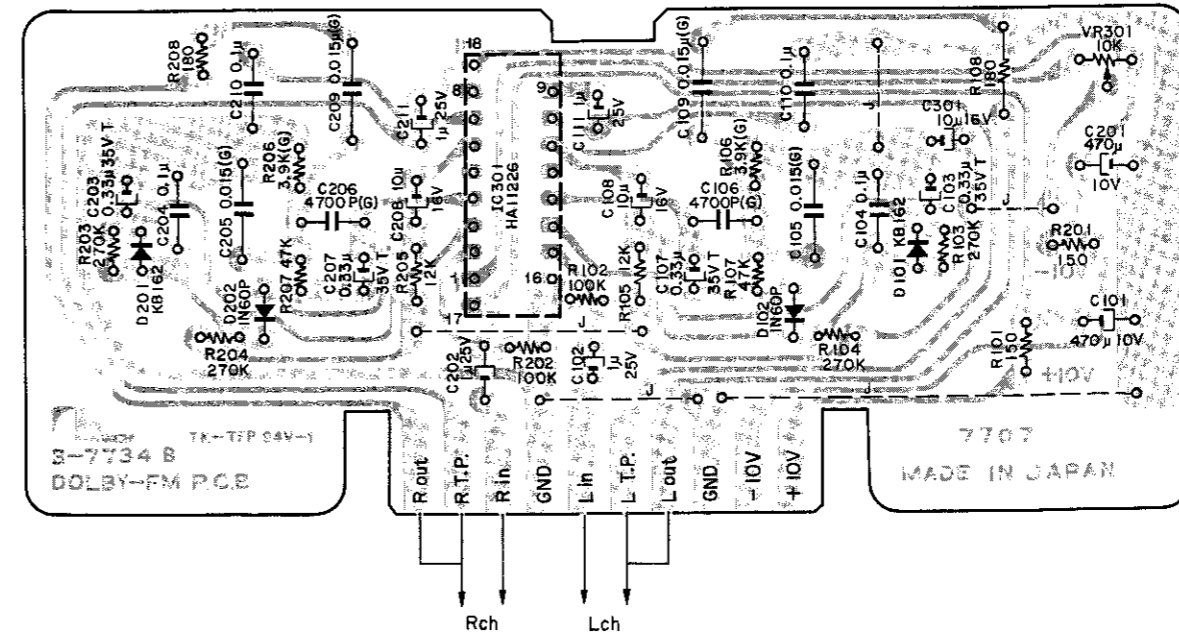
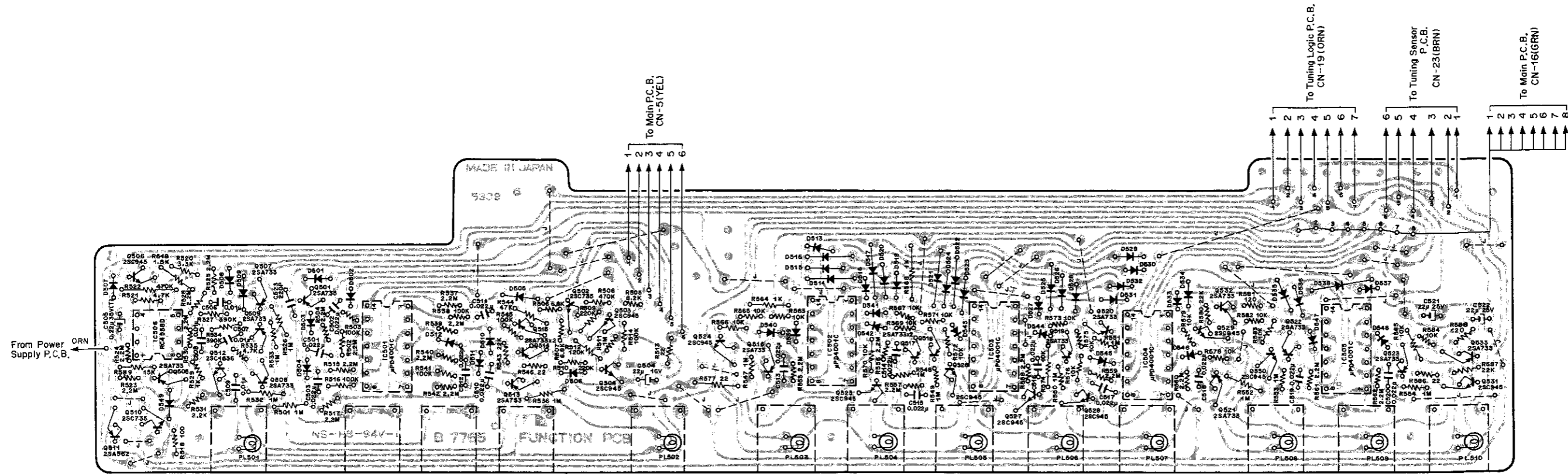

Fig. 6.3

Schematic Ref. No.	Part No.	Description
	BA03879A	DOLBY NR P.C.B. Ass'y
IC301	OB07734B	DOLBY NR P.C.B.
D101, 201	OB06118A	IC HA11226
D102, 202	OB01599A	Silicon Varistor KB162
VR301	OB00030A	Germanium Diode 1N60P
R101, 201	OB07162A	Semi-fixed Volume 10K
R102, 202	OB05649A	Carbon Resistor 150 ERD-25V J
R103, 104	OB01920A	Carbon Resistor 100K ERD-25V J
203, 204	OB05600A	Carbon Resistor 270K ERD-25V J
R105, 205	OB05650A	Carbon Resistor 12K ERD-25V J
R106, 206	OB05948A	Metal Film Resistor 3.9K ER0-25VK G
R107, 207	OB05562A	Carbon Resistor 47K ERD-25V J
R108, 208	OB05607A	Carbon Resistor 180 ERD-25V J
C101, 201	OB05884A	Electrolytic Capacitor 470 μ 10V
C102, 202	OB01173A	Electrolytic Capacitor 1 μ 25V
111, 211		
C103, 107	OB05949A	Tantalum Capacitor 0.33 μ 35V
203, 207		
C104, 110	OB01780A	Mylar Capacitor 0.1 μ 50V J
204, 210		
C105, 109	OB05950A	P.P. Capacitor 0.015 μ 100V G
205, 209		
C106, 206	OB05951A	P.P. Capacitor 4700P 100V G
C108, 208	OB01412A	Electrolytic Capacitor 10 μ 16V
301		

6.4. Function Sensor P.C.B. Ass'y



Note: Diode is 1S1555 unless otherwise specified.

Fig. 6.4

Schematic Ref. No.	Part No.	Description	Schematic Ref. No.	Part No.	Description	Schematic Ref. No.	Part No.	Description
	BA03922B	Function Sensor P.C.B. Ass'y	R503,514	0B01920A	Carbon Resistor 100K ERD-25V J	C501,502	0B05953A	Ceramic Capacitor 0.022μ 25V (14 pcs.)
	0B07765C	Function Sensor P.C.B.	516,538			503		
IC501-505	0B06143A	IC μPD4001C	541,545	0B01878A	Carbon Resistor 8.2K ERD-25V J	510-520	0B01862A	Electrolytic Capacitor 22μ 16V
IC506	0B06124B	IC RC4558D	R505,507	0B01877A	Carbon Resistor 6.8K ERD-25V J	C504	0B05772A	Tantalum Capacitor 0.22μ 35V
Q501,505	0B06013A	Transistor 2SA733 (18 pcs.)	R508,522	0B05700A	Carbon Resistor 470K ERD-25V J	C506,507	0B09091A	Ceramic Capacitor 0.01μ 25V
507,508			R509,510	0B05596A	Carbon Resistor 220K ERD-25V J	508,509		
509,			R512	0B05568A	Carbon Resistor 120K ERD-25V J	C521,522	0B01527A	Electrolytic Capacitor 22μ 25V
513-523			R513,546	0B05606A	Carbon Resistor 22 ERD-25V J	C523	0B05879A	Ceramic Capacitor 220P 50V K
532,533			577,586			PL501-510	0B08466A	Lamp T3 (10 pcs.)
Q502,510	0B01338A	Transistor 2SC735	R518	0B05558A	Carbon Resistor 100 ERD-25V J	CN5	0B08486A	6P-H Connector Ass'y D101C
Q503,504	0B06100A	Transistor 2SC945A (11 pcs.)	R519	0B05505A	Carbon Resistor 1.5K ERD-25V J	CN16	0B08492A	8P-H Connector Ass'y D101C
506			R520	0B01793A	Carbon Resistor 3.3K ERD-25V J	CN19	0B08488A	7P-H Connector Ass'y D101A
524-531			R521,535	0B01795A	Carbon Resistor 4.7K ERD-25V J	CN23	0B08487A	6P-H Connector Ass'y D101D
Q511	0B01426A	Transistor 2SA562	R527,534	0B05595A	Carbon Resistor 390K ERD-25V J		0B08001A	Tab (1 pce.)
Q512	0B06070A	Transistor 2SC1636	R529,564	0B01781A	Carbon Resistor 1K ERD-25V J		0H03626A	Contact Spring (for lamp) (13 pcs.)
D501-549	0B01909A	Silicon Diode 1S1555	R531	0B05566A	Carbon Resistor 2.2K ERD-25V J			
R501,511	0B05564A	Carbon Resistor 1M ERD-25V J (14 pcs.)	R543,580	0B05661A	Carbon Resistor 22K ERD-25V J			
526,532			587					
533,536			R544	0B05562A	Carbon Resistor 47K ERD-25V J			
547-554			R563,565	0B01833A	Carbon Resistor 10K ERD-25V J (18 pcs.)			
R502,504	0B05672A	Carbon Resistor 2.2M ERD-25V J (21 pcs.)	566,567					
515,517			569-576					
523,524			578,579					
525,528			582-585					
530,537			R568	0B01857A	Carbon Resistor 1K ERD-25V J			
539,540			R581,588	0B05570A	Carbon Resistor 120 ERD-25V J			
542			R589	0B05591A	Carbon Resistor 15K ERD-25V J			
555-562								

6.5. Tuning Sensor P.C.B. Ass'y

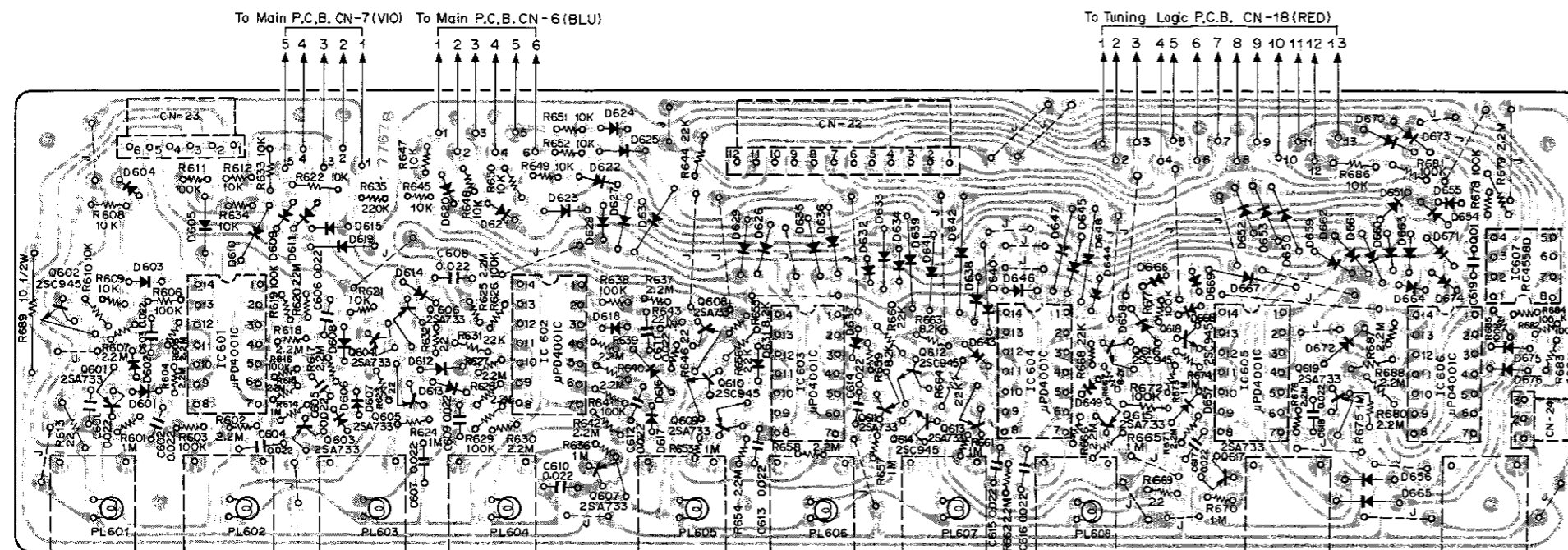

Fig. 6.5

Note: Diode is 1S1555 unless otherwise specified.

6.6. Tone Control P.C.B. Ass'y

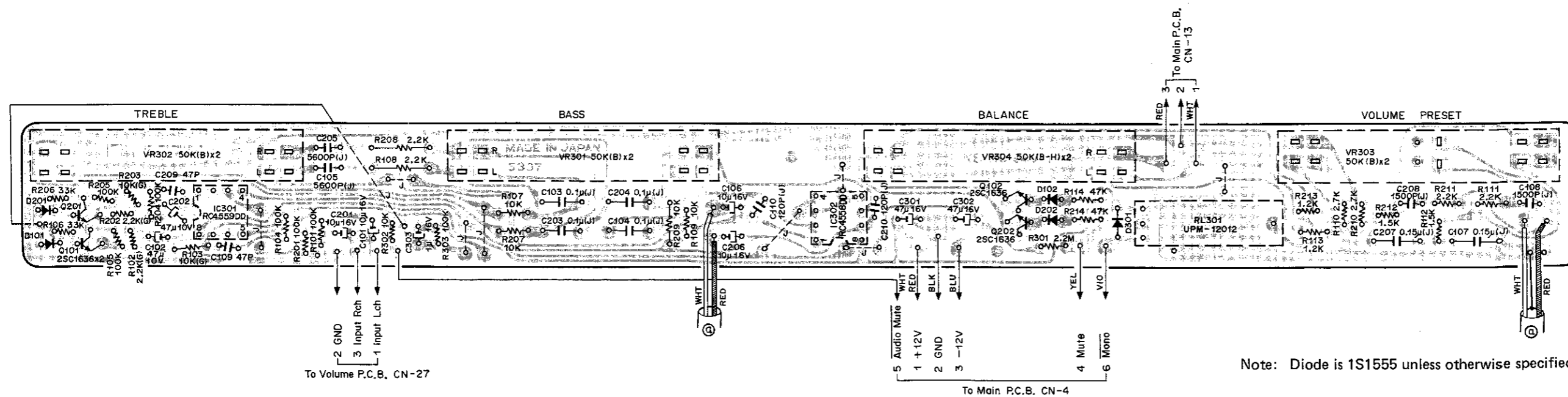

Fig. 6.6

Note: Diode is 1S1555 unless otherwise specified.

6.7. Lamp P.C.B. Ass'y

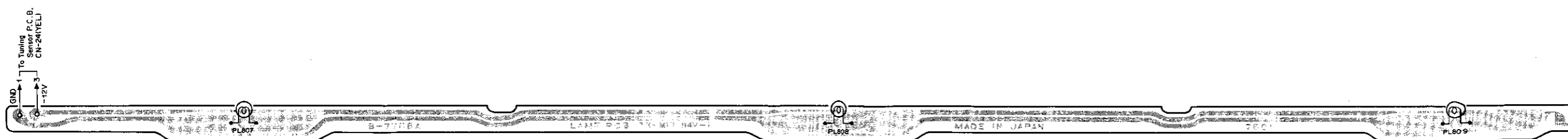
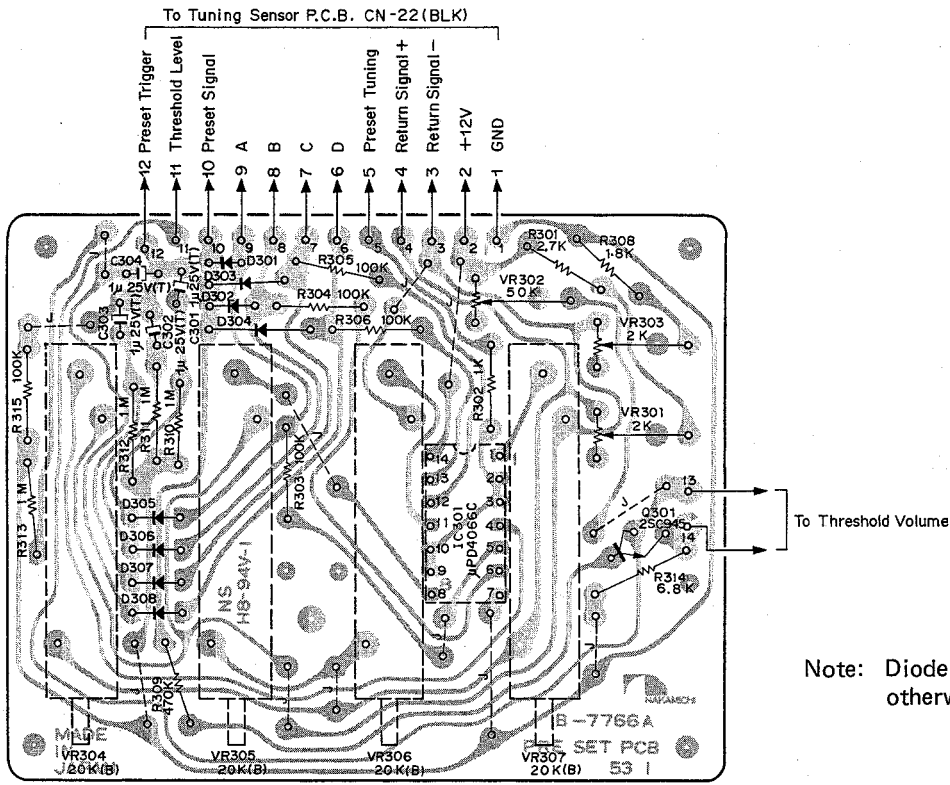

Fig. 6.7

Schematic Ref. No.	Part No.	Description	Schematic Ref. No.	Part No.	Description
	BA03923B	Tuning Sensor P.C.B. Ass'y	PL601-608	OB08466A	Lamp T3 (8 pcs.)
IC601-606	OB07767B	Tuning Sensor P.C.B.	CN6	OB08485A	6P-H Connector Ass'y D101B
IC607	OB06143A	IC μ PD4001C (6 pcs.)	CN7	OB08482A	5P-H Connector Ass'y D101B
Q601	OB06124B	IC RC4558D	CN18	OB08494A	13P-H Connector Ass'y D101
603-609	OB06013A	Transistor 2SA733 (13 pcs.)	CN22	OB05201A	12P-S Post
611,613			CN23	OB08181A	6P-S Post
615,617			CN24	OB08184A	3P-S Post
619				OH03626A	Contact Spring (for lamp) (10 pcs.)
Q602,610	OB06100A	Transistor 2SC945A		BA03920A	Tone Control P.C.B. Ass'y
612,614			IC301	OB07756B	Tone Control P.C.B.
616,618			IC302	OB06205A	IC RC4559DD
D601-676	OB01909A	Silicon Diode 1S1555 (76 pcs.)	Q101,102	OB06146A	IC RC4558DD
R601,614	OB05564A	Carbon Resistor 1M ERD-25V J	201,202	OB06070A	Transistor 2SC1636
624,636			D101,102		
653,657			201,202	OB01909A	Silicon Diode 1S1555
661,665			301		
670,673			VR301,302	OB07210A	Slide Volume 50K(B) x 2
674,675			VR303	OB07207A	Slide Volume 50K(B) x 2
R602,604	OB05672A	Carbon Resistor 2.2M ERD-25V J	VR304	OB07209A	Slide Volume 50K(BH) x 2
605,607			R101,104	OB01920A	Carbon Resistor 100K ERD-25V J
615,617			105,201		
618,620			204,205		
625,627			303	OB09101A	Metal Film Resistor 2.2K ERO-25VK G
628,630			R102,202	OB05895A	Metal Film Resistor 10K ERO-25VK G
637,639			R103,203	OB01879A	Carbon Resistor 33K ERD-25V J
640,642			R106,206	OB01833A	Carbon Resistor 10K ERD-25V J
654,658			R107,109		
662,666			207,209		
671,676			302	OB05622A	Carbon Resistor 2.2K ERD-25T J
679,680			R108,208	OB01782A	Carbon Resistor 2.7K ERD-25V J
R603,606	OB01920A	Carbon Resistor 100K ERD-25V J	R110,210	OB05566A	Carbon Resistor 2.2K ERD-25V J
611,616			R111,211	OB05505A	Carbon Resistor 1.5K ERD-25V J
619,626			R112,212	OB05565A	Carbon Resistor 1.2K ERD-25V J
629,638			R113,213	OB05562A	Carbon Resistor 47K ERD-25V J
641,672			R114,214	OB05672A	Carbon Resistor 2.2M ERD-25V J
677,678			R301	OB01412A	Electrolytic Capacitor 10 μ 16V
681,682			C101,106		
683,684			201,206	OB01836A	Electrolytic Capacitor 47 μ 10V
685			C102,202	OB01780A	Mylar Capacitor 0.1 μ 50V J
R608,609	OB01833A	Carbon Resistor 10K ERD-25V J	C103,104		
610,612			203,204		
621,622			C105,205	OB05659A	Mylar Capacitor 5600P 50V J
633,634			C107,207	OB05914A	Mylar Capacitor 0.15 μ 50V J
645,647			C108,208	OB05653A	Mylar Capacitor 1500P 50V J
648,649			C109,209	OB01456A	Ceramic Capacitor 47P 50V
650,651			C110,210	OB05787A	S.P. Capacitor 120P 50V J
652,686			C301,302	OB01403A	Electrolytic Capacitor 47 μ 16V
R613,623	OB05606A	Carbon Resistor 22 ERD-25V J	C303	OB01405A	Electrolytic Capacitor 1 μ 16V
632,646			RL301	OB07213A	Reed Relay UPM-12012
669			CN4	OB08484B	6P-H Connector Ass'y D101A
R631,643	OB05661A	Carbon Resistor 22K ERD-25V J	CN13	OB08472B	3P-H Connector Ass'y D101D
644,656			CN27	OB08474B	3P-H Connector Ass'y D101F
660,664				BA04012A	Lamp P.C.B. Ass'y
668				OB07768A	Lamp P.C.B.
R635	OB05596A	Carbon Resistor 220K ERD-25V J		OB08466A	Lamp T3 (3 pcs.)
R655,659	OB01878A	Carbon Resistor 8.2K ERD-25V J	PL807-809	OB08471A	3P-H Connector Ass'y D101C
663,667			CN24		
R687,688	OB05671A	Carbon Resistor 2.2M ERD-25T J			
R689	OB09092A	Metal Film Resistor 10 ERD-12F J			
C601-618	OB05953A	Ceramic Capacitor 0.022 μ 25V (18 pcs.)			
C619	OB09091A	Ceramic Capacitor 0.01 μ 25V			

6.8. Preset P.C.B. Ass'y



Note: Diode is 1S1555 unless otherwise specified.

Fig. 6.8

6.9. Tuning Logic P.C.B. Ass'y

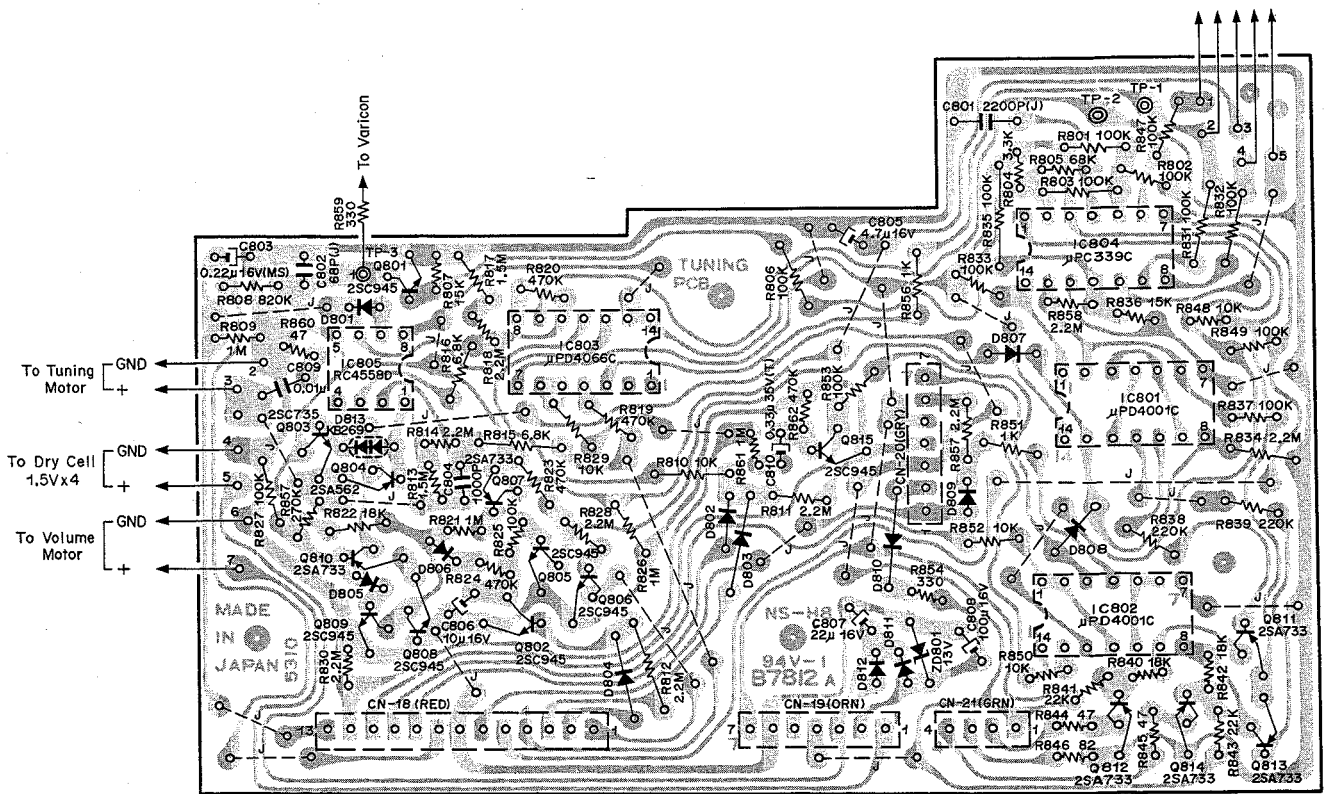

Fig. 6.9

Note: Diode is 1S1555 unless otherwise specified.

Schematic Ref. No.	Part No.	Description	Schematic Ref. No.	Part No.	Description
	BA03919A	Preset P.C.B. Ass'y	R819,820 823,824 862	0B05700A	Carbon Resistor 470K ERD-25V J
	0B07766A	Preset P.C.B.			
IC301	0B06144A	IC μ PD4066C	R822,840	0B05561A	Carbon Resistor 18K ERD-25V J
Q301	0B06100A	Transistor 2SC945A	842		
D301-308	0B01909A	Silicon Diode 1S1555 (8 pcs.)	R838,839	0B05596A	Carbon Resistor 220K ERD-25V J
VR301,303	0B09106A	Semi-fixed Volume 2K	R841,843	0B05661A	Carbon Resistor 22K ERD-25V J
VR302	0B07228A	Semi-fixed Volume 50K	R844,845	0B05569A	Carbon Resistor 47 ERD-25V J
VR304,305 306,307	0B07214A	Volume 20K (B)	R846	0B05503A	Carbon Resistor 82 ERD-25V J
R301	0B05629A	Carbon Resistor 2.7K ERD-25T J	R851,856	0B01781A	Carbon Resistor 1K ERD-25V J
R302	0B01857A	Carbon Resistor 1K ERD-25T J	R854	0B01789A	Carbon Resistor 330 ERD-25V J
R303-306 315	0B01889A	Carbon Resistor 100K ERD-25T J	R857	0B05600A	Carbon Resistor 270K ERD-25V J
R308	0B05614A	Carbon Resistor 1.8K ERD-25T J	R859	0B05577A	Carbon Resistor 330 ERD-25T J
R309	0B01684A	Carbon Resistor 470K ERD-25T J	R860	0B01706A	Carbon Resistor 47 ERD-25T J
R310-313	0B05776A	Carbon Resistor 1M ERD-25T J	C801	0B09105A	S.P. Capacitor 2200P 50V J
R314	0B01682A	Carbon Resistor 6.8K ERD-25T J	C802	0B09104A	S.P. Capacitor 68P 50V J
C301-304	0B09094A	Tantalum Capacitor 1 μ 25V	C803	0B09109A	Electrolytic Capacitor 0.22 μ 16V M(MS)
CN22	0B08493A	12P-H Connector Ass'y D101	C804	0B09103A	Ceramic Capacitor 1000P 25V
	BA03921C	Tuning Logic P.C.B. Ass'y	C805	0B01389A	Electrolytic Capacitor 4.7 μ 16V
	0B07812A	Tuning Logic P.C.B.	C806	0B01412A	Electrolytic Capacitor 10 μ 16V
IC801,802	0B06143A	IC μ PD4001C	C807	0B01862A	Electrolytic Capacitor 22 μ 16V
IC803	0B06144A	IC μ PD4066C	C808	0B01400A	Electrolytic Capacitor 100 μ 16V
IC804	0B06132A	IC μ PC339C	C809	0B09091A	Ceramic Capacitor 0.01 μ 25V
IC805	0B06124B	IC RC4558D	C810	0B05949A	Tantalum Capacitor 0.33 μ 35V
Q801,802 805,806 808,809 815	0B06100A	Transistor 2SC945A	TP1,2,3	0B03924A	Gate Pin
Q803	0B01338A	Transistor 2SC735	CN17	0B08481B	5P-H Connector Ass'y D101A
Q804	0B01426A	Transistor 2SA562	CN18	0B08506A	13P-T Post
Q807,810 811,812 813,814	0B06013A	Transistor 2SA733	CN19,20	0B08302A	7P-T Post
D801-812	0B01909A	Silicon Diode 1S1555	CN21	0B08236A	4P-T Post
D813	0B01702A	Varistor KB269			
ZD801	0B06009A	Zener Diode 13V EQA01-13R			
R801,802 803,806 825,827 831,832 833,835 837,847 849,853	0B01920A	Carbon Resistor 100K ERD-25V J			
R804	0B01793A	Carbon Resistor 3.3K ERD-25V J			
R805	0B05535A	Metal Film Resistor 68K ERO-25VK G			
R807,836	0B05591A	Carbon Resistor 15K ERD-25V J			
R808	0B09097A	Metal Film Resistor 820K ERO-25VK G			
R809,821 826,861	0B05564A	Carbon Resistor 1M ERD-25V J			
R810,829 848,850 852	0B01833A	Carbon Resistor 10K ERD-25V J			
R811,812 814,818 828,830 834,857 858	0B05672A	Carbon Resistor 2.2M ERD-25V J			
R813,817	0B05601A	Carbon Resistor 1.5M ERD-25V J			
R815,816	0B01877A	Carbon Resistor 6.8K ERD-25V J			

6.10. Power Block Ass'y

6.10.1. Power Amp. P.C.B. Ass'y

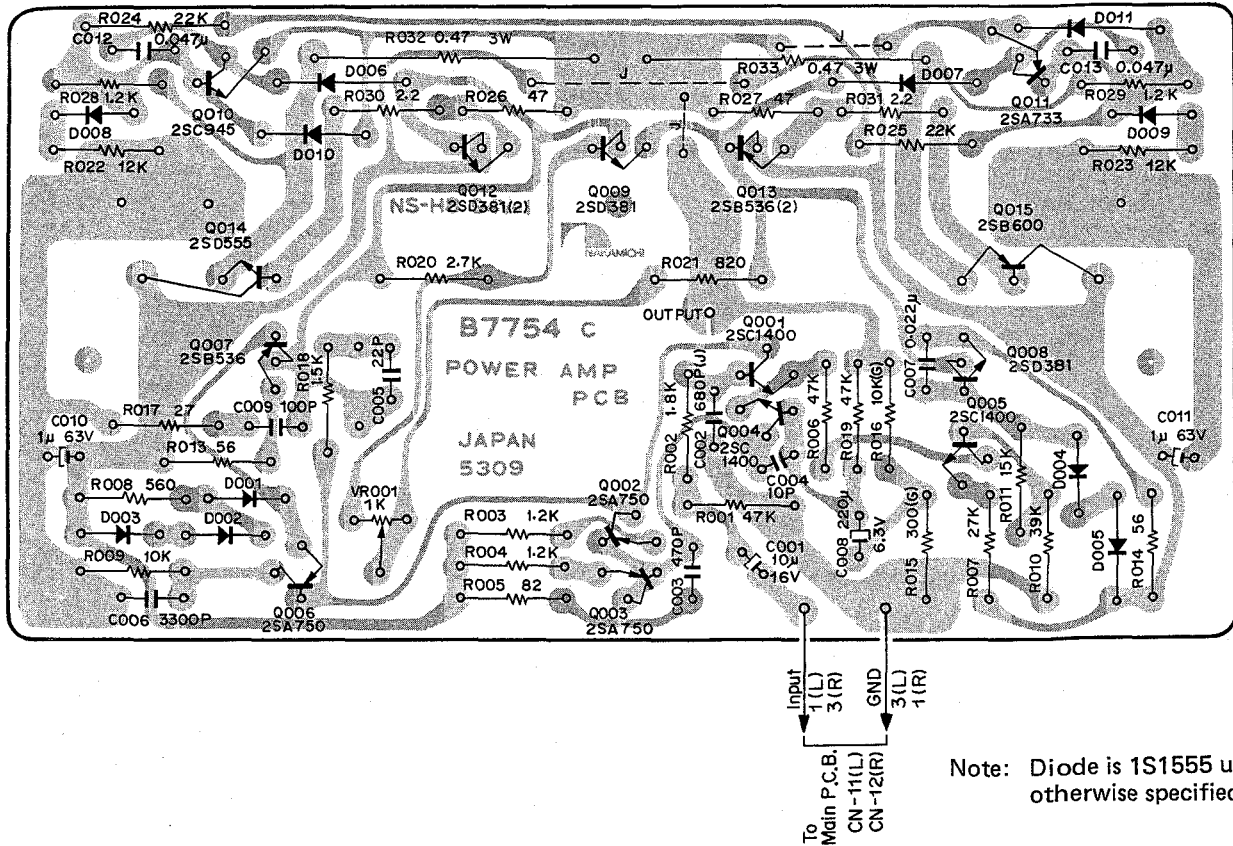

Fig. 6.10.1

6.10.2. Output P.C.B. Ass'y

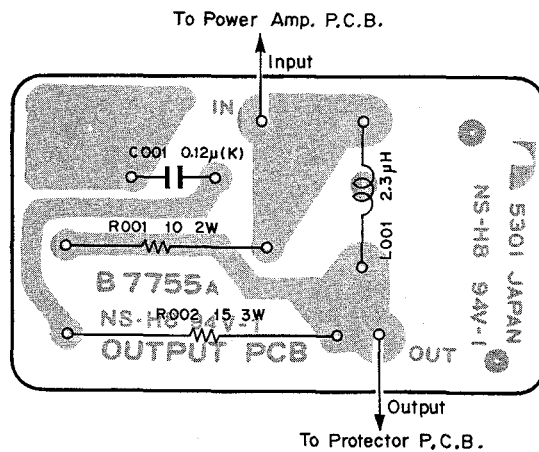

Fig. 6.10.2

Schematic Ref. No.	Part No.	Description	Schematic Ref. No.	Part No.	Description
	JA03282B	Power Block Ass'y (2 pcs.)	C001	0B01412A	Electrolytic Capacitor 10 μ 16V
	BA03932B	Power Amp. P.C.B. Ass'y	C002	0B09235A	P.P. Capacitor 680P 50V J
	BA03929A	Output P.C.B. Ass'y	C003	0B01716A	Ceramic Capacitor 470P 50V
Q009	0B06097A	Transistor 2SD381	C004	0B09077A	Ceramic Capacitor 10P 50V
Q012	0B06157A	Transistor 2SD381(2)K	C005	0B09095A	Ceramic Capacitor 22P 500V
Q013	0B06158A	Transistor 2SB536(2)K	C006	0B05881A	Ceramic Capacitor 3300P 50V
Q014	0B06083A	Transistor 2SD555	C007	0B05882A	Ceramic Capacitor 0.022 μ 50V
Q015	0B06081A	Transistor 2SB600	C008	0B01394A	Electrolytic Capacitor 220 μ 6.3V
	0B08498A	Transistor Socket (2 pcs.)	C009	0B05892A	Ceramic Capacitor 100P 50V K
	0B08531A	Bushing for Transistor (3 pcs.)	C010,011	0B09082A	Electrolytic Capacitor 1 μ 63V
	0B08532A	Washer for Transistor (3 pcs.)	C012,013	0B05811A	Mylar Capacitor 0.047 μ 50V K
	0J03560A	Spring Pin (2 pcs.)		0E00757A	Screw M3x6 Philips Pan Head (Polycarbonate) (2 pcs.)
	0J03830A	Heat Sink D1 A (1 pce.)		0E00758A	Nut Hex. M3 (Polycarbonate) (2 pcs.)
	0J03831A	Output P.C.B. Stud (2 pcs.)			
	0E00231A	FT Screw M2.6 x 8 Philips Pan Head (3 pcs.)		BA03929A	Output P.C.B. Ass'y (2 pcs.)
	0E00502A	Screw M3x5 Philips Pan Head (2 pcs.)	L001	0B07755A	Output P.C.B.
	0E00606A	Screw M3x6 Philips Pan Head (3A) (2 pcs.)	R001	BA03784A	Output Coil Ass'y 2.3 μ H
	0E00718A	Nut Hex. M3 (3 pcs.)	R002	0B05906A	Fail Safe Type Resistor 10 ERX-2AN J
	0E00723A	Washer 3mm Spring (7 pcs.)	R002	0B05907A	Fail Safe Type Resistor 15 ERX-3AN J
	0E00732A	Washer 3mm (8 pcs.)	C001	0B01772A	Mylar Capacitor 0.12 μ 50V K
	0E00741A	Screw M3x12 Philips Binding Head (3 pcs.)			
	0E00871A	Screw M3x18 Philips Binding Head (4 pcs.)			
	BA03932B	Power Amp. P.C.B. Ass'y (2 pcs.)			
Q001,004	0B07754C	Power Amp. P.C.B.			
005	0B06078A	Transistor 2SC1400			
Q002,003	0B06074A	Transistor 2SA750(1)			
006					
Q007	0B06096A	Transistor 2SB536 (K,L,M)			
Q008	0B06097A	Transistor 2SD381 (K,L,M)			
Q010	0B06100A	Transistor 2SC945A			
Q011	0B06013A	Transistor 2SA733			
D001-011	0B01909A	Silicon Diode 1S1555 (11 pcs.)			
VR001	0B09083A	Semi-fixed Volume 1K			
R001,006	0B05641A	Carbon Resistor 47K ERD-25T J			
019					
R002	0B05614A	Carbon Resistor 1.8K ERD-25T J			
R003,004	0B05926A	Fail Safe Type Resistor 1.2K ERD-14F J			
028,029					
R005	0B05631A	Carbon Resistor 82 ERD-25T J			
R007	0B05743A	Carbon Resistor 27K ERD-25T J			
R008	0B05575A	Carbon Resistor 560 ERD-25T J			
R009	0B01888A	Carbon Resistor 10K ERD-25T J			
R010	0B01854A	Carbon Resistor 39K ERD-25T J			
R011	0B01683A	Carbon Resistor 15K ERD-25T J			
R013,014	0B05947A	Fail Safe Type Resistor 56 ERD-14F J			
R015	0B09084A	Metal Film Resistor 300 ERO-25CK G			
R016	0B09096A	Metal Film Resistor 10K ERO-25CK G			
R017	0B05875A	Carbon Resistor 27 ERD-25T J			
R018	0B05698A	Carbon Resistor 1.5K ERD-25T J			
R020	0B05629A	Carbon Resistor 2.7K ERD-25T J			
R021	0B01680A	Carbon Resistor 820 ERD-25T J			
R022,023	0B05771A	Carbon Resistor 12K ERD-25T J			
R024,025	0B05615A	Carbon Resistor 22K ERD-25T J			
R026,027	0B05923A	Fail Safe Type Resistor 47 ERD-14F J			
R030,031	0B05931A	Fail Safe Type Resistor 2.2 ERD-14F J			
R032,033	0B05902A	Fail Safe Type Resistor 0.47 ERX-3AN J			

6.11. Protector P.C.B. Ass'y

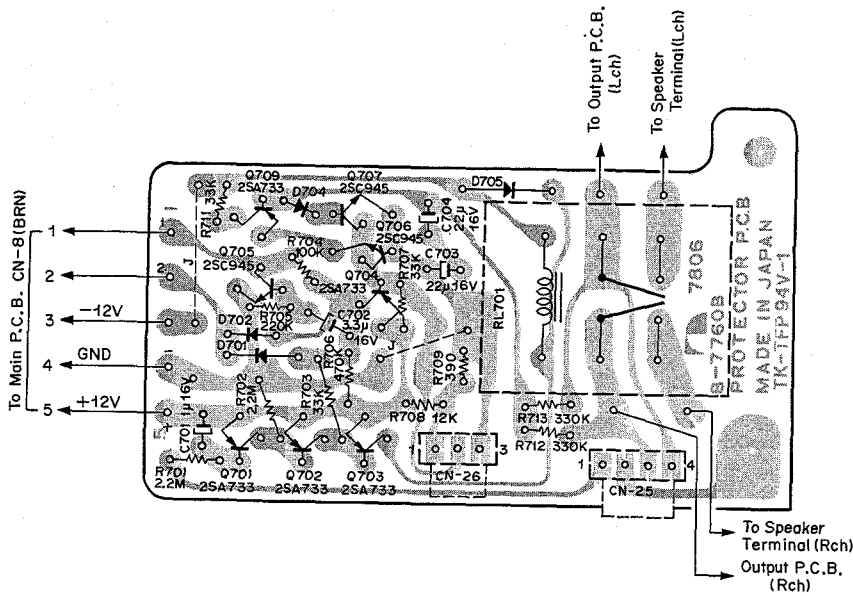

Fig. 6.11

6.13. Fuse P.C.B. Ass'y

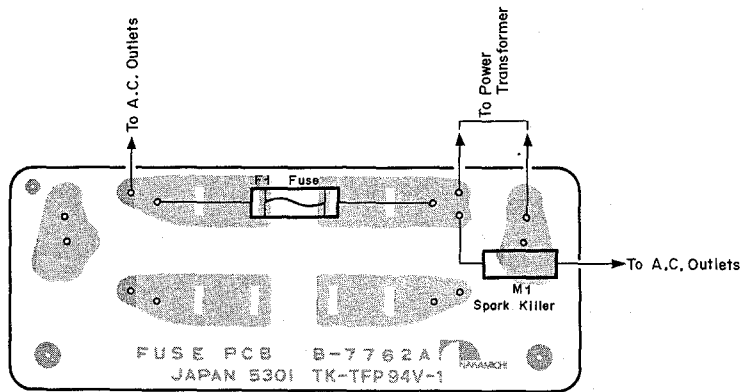

Fig. 6.13

6.14. Capacitor P.C.B. Ass'y

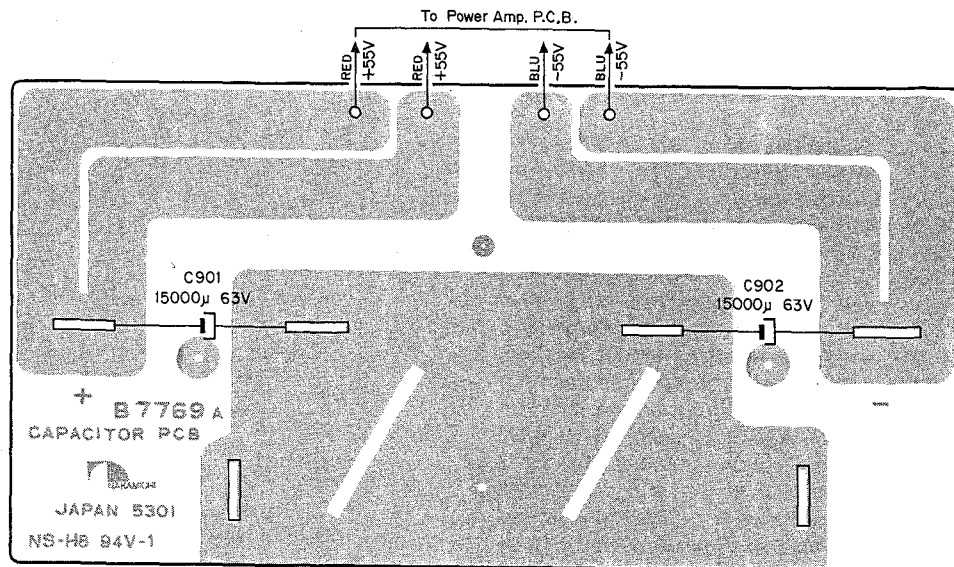

Fig. 6.14

6.12. Headphone P.C.B. Ass'y

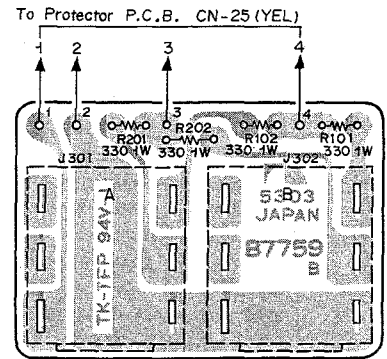

Fig. 6.12

Note: Diode is 1S1555 unless otherwise specified.

6.15. Volume Lamp P.C.B. Ass'y

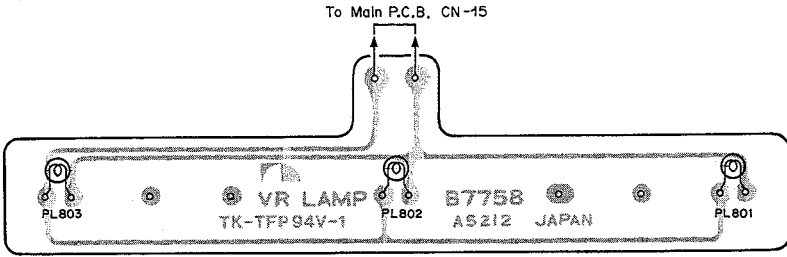

Fig. 6.15

6.16. Tuning Lamp P.C.B. Ass'y

Mounting diagram is omitted.

6.17. Volume P.C.B. Ass'y

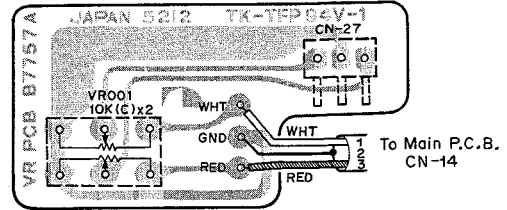

Fig. 6.16

Schematic Ref. No.	Part No.	Description	Schematic Ref. No.	Part No.	Description
	BA03918B	Protector P.C.B. Ass'y		OB08282U	Fuse 5AT 250V (SWEDEN, AUSTRALIA, UK & OTHERS)
Q701,702 703,704 709	OB07760B OB06013A	Protector P.C.B. Transistor 2SA733	M1	OB08363A OB08342A OB08445A OB08240A	Spark Killer (JAPAN) Spark Killer (U.S.A. & CANADA) Spark Killer (SWEDEN) Spark Killer (AUSTRALIA, UK & OTHERS)
Q705,706 707	OB06100A	Transistor 2SC945A		OB08365A OB08349A	Fuse Cap (2 pcs.) (JAPAN, U.S.A. & CANADA) Fuse Clip (2 pcs.) (SWEDEN, AUSTRALIA, UK & OTHERS)
D701,702 704,705	OB01909A	Silicon Diode 1S1555		OB08359A 0M03933A 0M03751A	Spark Killer Cover (1 pce.) Fuse Label 6.25AT 125V (1 pce.) (JAPAN, U.S.A. & CANADA) Fuse Label 5AT 250V (1 pce.) (SWEDEN, AUSTRALIA, UK & OTHERS)
R701,702 R703,707 711	OB05672A OB01879A	Carbon Resistor 2.2M ERD-25V J Carbon Resistor 33K ERD-25V J		BA03944A	Capacitor P.C.B. Ass'y
R704 R705 R706 R708 R709 R712,713	OB01920A OB05596A OB05700A OB05650A OB05688A OB01921A	Carbon Resistor 100K ERD-25V J Carbon Resistor 220K ERD-25V J Carbon Resistor 470K ERD-25V J Carbon Resistor 12K ERD-25V J Carbon Resistor 390 ERD-25V J Carbon Resistor 330K ERD-25V J		OB07769A OB09115A OB08467A OB05197B OB05198B	Capacitor P.C.B. Electrolytic Capacitor 15000μ 63V Capacitor Holder (1 pce.) Cord A D101 (with terminals) (2 pcs.) Cord B D101 (with terminals) (2 pcs.)
C701 C702 C703,704 RL701 CN8 CN25 CN26	OB01405A OB01863A OB01862A OB07212A OB08483A OB08375A OB08184A	Electrolytic Capacitor 1μ 16V Electrolytic Capacitor 3.3μ 16V Electrolytic Capacitor 22μ 16V Speaker Relay 24V MY4-02-US-40L 5P-H Connector Ass'y D101C 4P-S Post 3P-S Post	C901,902	BA03926A OB07758A OB08465A OB08476B	Volume Lamp P.C.B. Ass'y Volume Lamp P.C.B. Lamp T4.2 3P-H Connector Ass'y D101H
R101,102 201,202 CN25 J301,302	BA03928A OB07759B OB07785A OB08478A OB08511A	Headphone P.C.B. Ass'y Headphone P.C.B. Fail Safe Type Resistor 330 ERX-1AN J 4P-H Connector Ass'y D101B Headphone Jack	PL801,802 803 CN15	BA03943A OB07781B OB08466A OB08480A	Tuning Lamp P.C.B. Ass'y Tuning Lamp P.C.B. Lamp T3 4P-H Connector Ass'y D101D
F1	BA04005A BA04006A BA04007A BA04008A BA04011A OB07762A OB08526A	Fuse P.C.B. Ass'y (JAPAN) Fuse P.C.B. Ass'y (U.S.A. & CANADA) Fuse P.C.B. Ass'y (SWEDEN) Fuse P.C.B. Ass'y (AUSTRALIA & UK) Fuse P.C.B. Ass'y (OTHERS) Fuse P.C.B. Fuse 6.25AT 125V (JAPAN, U.S.A. & CANADA)	PL804,805 806 CN21 VR001 CN14 CN27	BA03925A OB07757A OB07205B OB08473B OB08184A	Volume P.C.B. Ass'y Volume P.C.B. Volume 10K (C) x 2 3P-H Connector Ass'y D101E 3P-S Post

6.18. Power Supply P.C.B. Ass'y

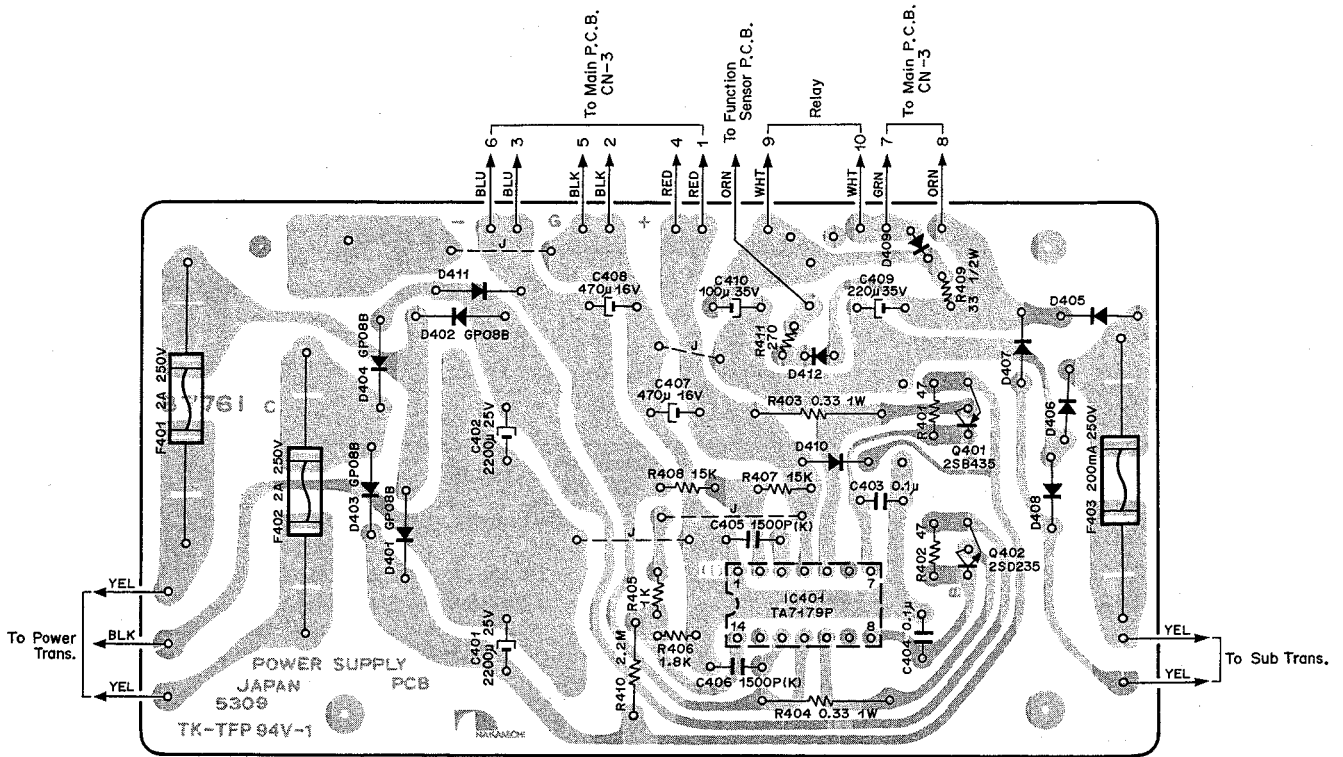

Fig. 6.17 Note: Diode is 1S1555 unless otherwise specified.

Schematic Ref. No.	Part No.	Description	Schematic Ref. No.	Part No.	Description
	BA04009A	Power Supply P.C.B. Ass'y (JAPAN)	F403	0B08517A	Fuse 200mA (JAPAN) (1 pce.)
	BA04010A	Power Supply P.C.B. Ass'y (U.S.A. & CANADA)		0B08524A	Fuse 200mA (U.S.A. & CANADA) (1 pce.)
	BA03931B	Power Supply P.C.B. Ass'y		0B08520A	Fuse 200mA (1 pce.)
	0B07761C	Power Supply P.C.B.		0J03835D	Heat Sink D1-B (1 pce.)
IC401	0B06150A	IC TA7179P		0B08349A	Fuse Clip (JAPAN) (6 pcs.)
Q401	0B06011A	Transistor 2SB435		0B08349A	Fuse Clip (6 pcs.)
Q402	0B01823A	Transistor 2SD235		0B08365A	Fuse Cap (U.S.A. & CANADA) (6 pcs.)
D401-404	0B06109A	Silicon Diode GP08 (4 pcs.)		0M03937A	Fuse Label 2A 250V (2 pcs.)
D405-412	0B01909A	Silicon Diode 1S1555 (8 pcs.)		0M03938B	Fuse Label 200mA 250V (1 pce.)
R401,402	0B05569A	Carbon Resistor 47 ERD-25V J		0E00507A	Nut Hex. M3 (2 pcs.)
R403,404	0B09085A	Fail Safe Type Resistor 0.33 ERX-1AN J		0E00608A	Screw M3x10 Philips Pan Head (3A) (2 pcs.)
R405	0B01781A	Carbon Resistor 1K ERD-25V J		0E00607A	Screw M3x8 Philips Pan Head (3A) (2 pcs.)
R406	0B01830A	Carbon Resistor 1.8K ERD-25V J			
R407,408	0B05591A	Carbon Resistor 15K ERD-25V J			
R409	0B09086A	Fail Safe Type Resistor 33 ERD-12F J			
R410	0B05671A	Carbon Resistor 2.2M ERD-25T J			
R411	0B05651A	Carbon Resistor 270 ERD-25V J			
C401,402	0B05654A	Electrolytic Capacitor 2200μ 25V			
C403,404	0B01356A	Ceramic Capacitor 0.1μ 50V			
C405,406	0B01711A	Mylar Capacitor 1500P 50V K			
C407,408	0B01392A	Electrolytic Capacitor 470μ 16V			
C409	0B05831A	Electrolytic Capacitor 220μ 35V			
C410	0B09126A	Electrolytic Capacitor 100μ 35V			
CN3	0B08491B	8P-H Connector Ass'y D101B			
F401,402	0B08518A	Fuse 2A (JAPAN) (2 pcs.)			
	0B08525A	Fuse 2A (U.S.A. & CANADA) (2 pcs.)			
	0B08100A	Fuse 2A (2 pcs.)			

7. MECHANISM ASS'Y AND PARTS LIST

7.1. Synthesis

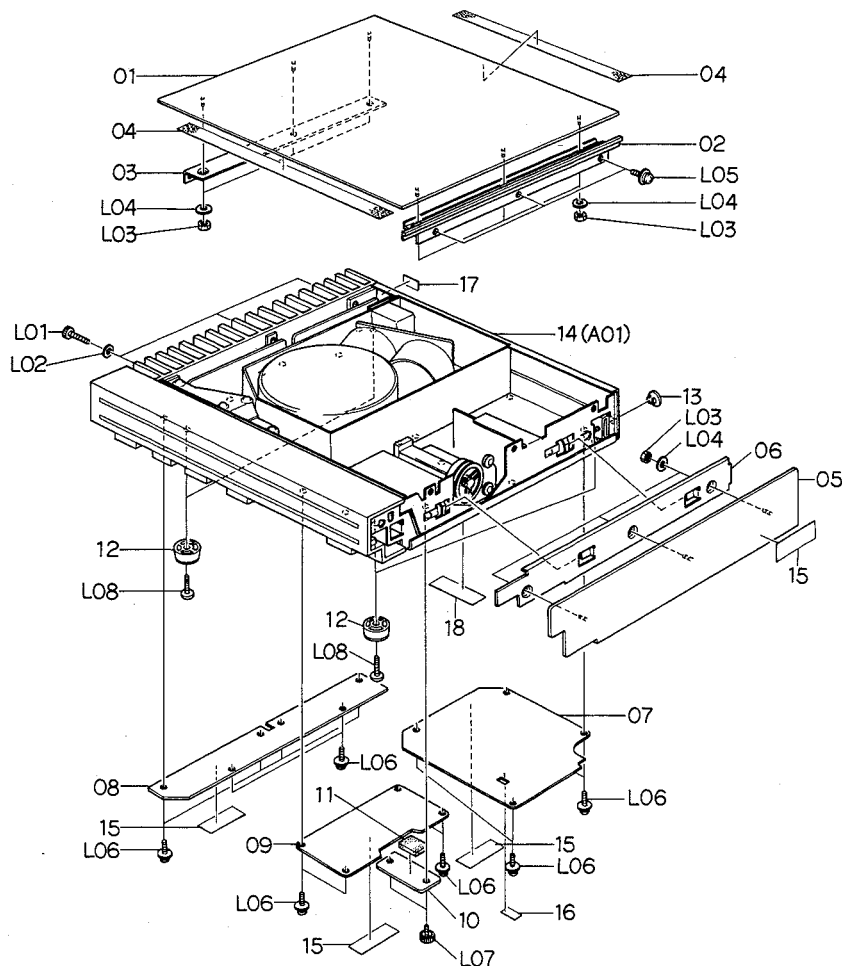

Fig. 7.1

Schematic Ref. No.	Part No.	Description	Q'ty	Schematic Ref. No.	Part No.	Description	Q'ty
		Synthesis			JA03429A	Synthesis Mechanism 730 (OTHERS)	1
01	0H03609C	Top Cover	1		JA03430A	Synthesis Mechanism 730 (UK)	1
02	0H03611C	Corner Sash	1		JA03445A	Synthesis Mechanism 730 (GERMANY)	1
03	0H03610A	Top Cover Holder	1				
04	0H03648A	Top Cover Himelton 730	2	15	0M03799A	Caution Label G	4
05	0H03608C	Side Panel R	1	16	0M03838A	Time Constant Label	1
06	0H03612B	Side Plate	1	17	0M03551A	Pass Label B	1
07	0J03866B	Bottom Cover A	1	18	0M03330A	Dolby NR Label	1
08	0J03867B	Bottom Cover B	1	*	0M03800A	Caution Label H	5
09	0J03868A	Bottom Cover C	1	*	0M03883A	Lamp Caution Label	4
10	0J03818B	Battery Cover	1	L01	0E00747A	Screw M4 x 15 Hex. Socket Head	3
11	0H03644A	Battery Cushion	1	L02	0J03556A	Washer 4mm	3
12	0J03825A	Leg S	4	L03	0E00669A	Nut Hex. M4	9
13	0J03828A	Hole Plug	1	L04	0E00141A	Washer 4mm	9
14	JA03424A	Synthesis Mechanism 730(JAPAN)	1	L05	0E00607A	Screw M3 x 8 Philips Pan Head (3A)	3
	JA03425A	Synthesis Mechanism 730 (U.S.A.)	1	L06	0E00522A	Screw M4 x 4 Philips Pan Head	14
	JA03426A	Synthesis Mechanism 730 (CANADA)	1	L07	0E00802A	Screw M3 x 6 Philips Pan Head	2
	JA03427A	Synthesis Mechanism 730 (OTHERS)	1	L08	0E00803A	Screw M4 x 10 Philips Binding Head (Bronze)	4
	JA03428A	Synthesis Mechanism 730 (SWEDEN)	1			*: For U.S.A. & CANADA only.	

7.2. Synthesis Mechanism 730 (A01)

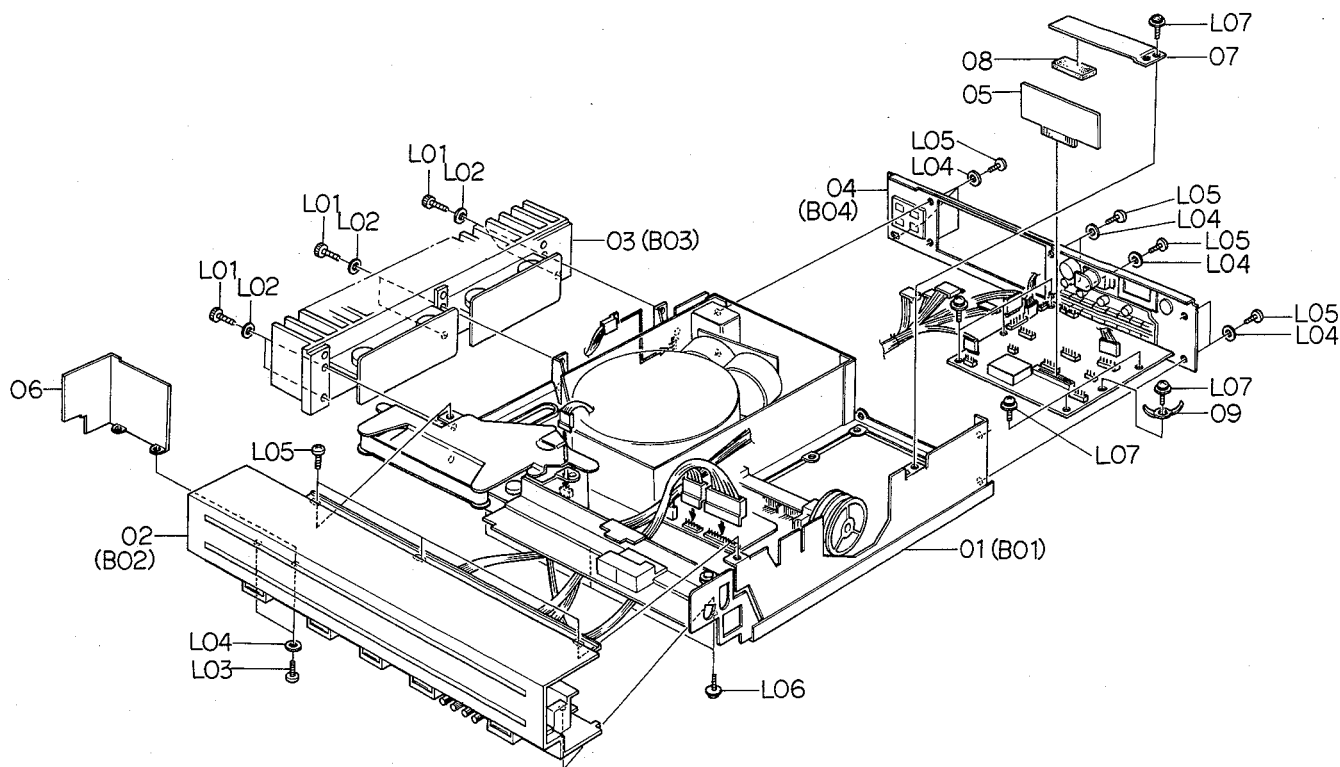

Fig. 7.2

Schematic Ref. No.	Part No.	Description	Q'ty	Schematic Ref. No.	Part No.	Description	Q'ty
A01	JA03424A	Synthesis Mechanism 730 (JAPAN)	1	*05	BA03879A	Dolby NR P.C.B. Ass'y	1
	JA03425A	Synthesis Mechanism 730 (U.S.A.)	1	06	0H03588B	Side Panel L	1
	JA03426A	Synthesis Mechanism 730 (CANADA)	1	07	0J03797B	NR P.C.B. Holder	1
	JA03427A	Synthesis Mechanism 730 (AUSTRALIA)	1	08	0J03801A	P.C.B. Cushion	1
	JA03428A	Synthesis Mechanism 730 (SWEDEN)	1	09	0B03067A	Wire Holder	1
	JA03429A	Synthesis Mechanism 730 (OTHERS)	1	L01	0E00747A	Screw M4 x 15 Hex. Socket Head	6
	JA03430A	Synthesis Mechanism 730 (UK)	1	L02	0J03556A	Washer 4mm	6
	JA03445A	Synthesis Mechanism 730 (GERMANY)	1	L03	0E00594A	Screw M3 x 8 Philips Binding Head (Bronze)	2
				L04	0E00157A	Washer 3mm Plastics	10
				L05	0E00593A	Screw M3 x 6 Philips Binding Head (Bronze)	11
01	JA03432A	Main Chassis Ass'y (JAPAN)	1	L06	0E00643A	Screw M4 x 8 Philips Pan Head (3A)	3
	JA03433A	Main Chassis Ass'y (U.S.A.)	1	L07	0E00606A	Screw M3 x 6 Philips Pan Head (3A)	7
	JA03434A	Main Chassis Ass'y (CANADA)	1				
	JA03435A	Main Chassis Ass'y (AUSTRALIA)	1				
	JA03436A	Main Chassis Ass'y (SWEDEN)	1				
	JA03437A	Main Chassis Ass'y (OTHERS)	1				
	JA03438A	Main Chassis Ass'y (U.K.)	1				
	JA03446A	Main Chassis Ass'y (GERMANY)	1				
	HA03751A	Front Panel Ass'y	1				
	02	HA03786A	Front Panel Ass'y (JAPAN)	1			
HA03792A		Front Panel Ass'y (UK)	1				
03	JA03281A	Side Panel Ass'y 730	1				
04	JA03280B	Rear Panel Ass'y	1				

*: Option except for U.S.A.

7.3. Main Chassis Ass'y (B01)

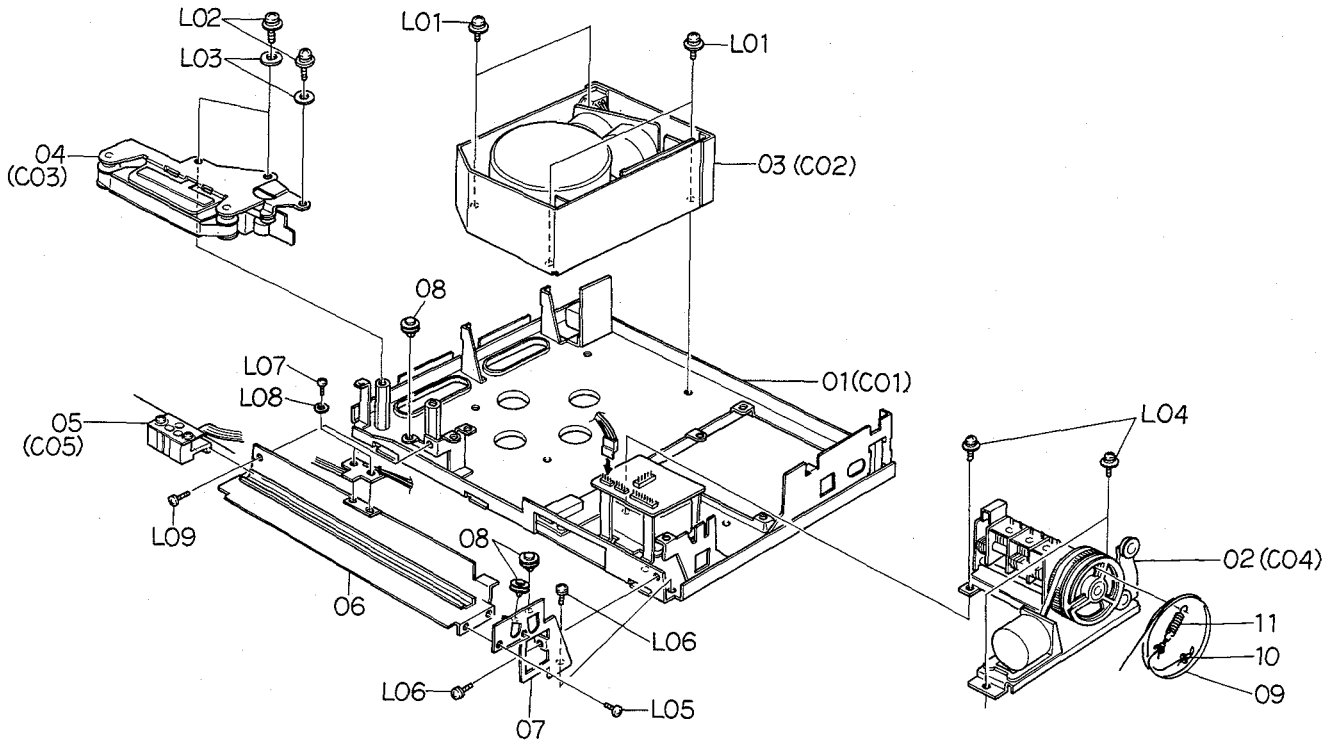

Fig. 7.3

Schematic Ref. No.	Part No.	Description	Q'ty	Schematic Ref. No.	Part No.	Description	Q'ty
B01	JA03432A	Main Chassis Ass'y (JAPAN)	1	09	JA03321A	Dial Thread Ass'y 730	1
	JA03433A	Main Chassis Ass'y (U.S.A.)	1	10	0E00752A	Thread Guide	1
	JA03434A	Main Chassis Ass'y (CANADA)	1	11	0J03907A	Pulley Spring	1
	JA03435A	Main Chassis Ass'y (AUSTRALIA)	1	L01	0E00643A	Screw M4 x 8 Philips Pan Head (3A)	4
	JA03436A	Main Chassis Ass'y (SWEDEN)	1	L02	0E00607A	Screw M3 x 8 Philips Pan Head (3A)	3
	JA03437A	Main Chassis Ass'y (OTHERS)	1	L03	0J03870A	Washer 10-3.1-1S	3
	JA03438A	Main Chassis Ass'y (UK)	1	L04	0E00606A	Screw M3 x 7 Philips Pan Head (3A)	3
	JA03446A	Main Chassis Ass'y (GERMANY)	1	L05	0E00509A	Screw M3 X 6 Philips Pan Head	2
01	JA03440A	Main Chassis Sub Ass'y	1	L06	0E00612A	Screw M3 x 6 Philips Pan Head (2A)	2
02	JA03268A	Front-end Control Ass'y	1	L07	0E00808A	Screw M2 x 4 Philips Pan Head (Bronze)	2
	JA03323A	Front-end Control Ass'y (JAPAN)	1				
03	JA03283B	Power Supply Ass'y (JAPAN)	1	L08	0C05035A	Take-up Thrust Plate	2
	JA03284A	Power Supply Ass'y (U.S.A.)	1				
	JA03285A	Power Supply Ass'y (CANADA)	1	L09	0E00593A	Screw M3 x 6 Philips Binding Head (Bronze)	1
	JA03324A	Power Supply Ass'y (AUSTRALIA)	1				
	JA03336A	Power Supply Ass'y (OTHERS)	1				
	JA03286A	Power Supply Ass'y (SWEDEN)	1				
	JA03287A	Power Supply Ass'y (UK)	1				
	JA03443A	Power Supply Ass'y (GERMANY)	1				
04	JA03277A	Volume Control Ass'y	1				
05	HA03755A	Lamp Base Ass'y	1				
06	JA03270A	Guide Plate Ass'y	1				
07	0J03805B	Guide Plate Holder	1				
08	JA03315A	Pulley Ass'y 730	3				

Schematic Ref. No.	Part No.	Description	Q'ty	Schematic Ref. No.	Part No.	Description	Q'ty
B02	HA03751A	Front Panel Ass'y	1	L06	0E00750A	Screw M2.6 x 8 Philips Binding Head (Bronze)	2
	HA03786A	Front Panel Ass'y (JAPAN)	1	L07	0E00651A	Washer 2.6mm Plastics	2
	HA03792A	Front Panel Ass'y (UK)	1	L08	0E00790A	ST Screw M2 x 3 Philips Pan Head	7
01	0H03587C	Front Panel	1	L09	0E00786A	ST Screw M2 x 5 Philips Pan Head	1
	0H03638B	Front Panel (JAPAN)	1	L10	0E00814A	ST Screw M2 x 4 Philips Pan Head	7
02	HA03787A	Threshold Control Knob Ass'y	1	L11	0E00761A	Screw M2 x 2.5 Philips Pan Head (Bronze)	10
03	HA03788A	Treble Control Knob Ass'y	1	L12	0E00816A	Screw M2.6 x 6 Philips Pan Head (2A)	6
04	HA03789A	Bass Control Knob Ass'y	1		L13	0E00821A	Screw M2 x 3 Philips Binding Head
05	HA03790A	Balance Control Knob Ass'y	1	L14	0E00791A	Screw M2.6 x 5 Philips Binding Head	8
06	HA03791A	Volume Preset Knob Ass'y	1	L15	0E00764A	Screw M2.6 x 6 Philips Pan Head (2A)	4
07	HA03747B	Preset Tuning Knob Ass'y	4		L16	0E00142A	Washer 2.6mm
08	BA03928A	Headphone P.C.B. Ass'y	1	L17	0E00219A	Screw M2.6 x 5 Philips Pan Head	4
09	0J03816A	Jack Holder	1	L18	0E00792A	BT Screw M2.6 x 6 Philips Pan Head	6
10	BA03922B	Function P.C.B. Ass'y	1				
11	BA03923A	Tuning Sensor P.C.B. Ass'y	1				
12	BA03920A	Tone Control P.C.B. Ass'y	1				
13	BA03919A	Preset P.C.B. Ass'y	1				
14	0B07208A	Slide Volume 10K (B)	1				
15	HA03754A	Reflector R Ass'y	1				
16	0J03815B	Volume Holder	1				
17	HA03753A	Reflector L Ass'y	1				
18	0J03811C	Supporter	4	B03	JA03281A	Side Panel Ass'y 730	1
19	0J03864A	Preset P.C.B. Holder	1	01	JA03282B	Power Block Ass'y 730	2
20	0J03810B	Front Chassis	1	02	BA03933B	Thermal Transistor Ass'y	1
21	0H03589B	Slide Volume Scale Plate A	2	03	0H03637C	Side Panel 730	1
22	0H03590B	Slide Volume Scale Plate B	1	04	0B08469B	3P-H Connector Ass'y A (Length 760mm)	1
23	0H03591B	Slide Volume Scale Plate C	1	05	0B08470C	3P-H Connector Ass'y B (Length 710mm)	1
24	0H03592B	Slide Volume Scale Plate D	1		06	0B08595A	Insulator Mica TO126
25	0H03642A	Rubber Shade A	1	L01	0E00745A	Screw M4 x 10 Hex. Socket Head	6
26	0H03643A	Rubber Shade B	4	L02	0J03556A	Washer 4mm	6
27	0J03812B	Arm Shaft	2	L03	0E00594A	Screw M3 x 8 Philips Binding Head (Bronze)	1
28	0J03813B	Volume Set Arm	5	L04	0E00581A	Washer 3mm Spring	1
29	0J03814B	Shaft Holder Plate	4	L05	0E00178A	Washer 3mm	1
30	0H03618B	Reflector Hold Plate	1				
31	0H03621B	Sensor Cover	1				
32	0H03623A	Sensor Plate B	4				
33	0H03622A	Sensor Plate A	19				
34	0H03617A	Smoked Lens	1				
35	0H03602A	Acrylic Cover	1				
36	0H03604C	Protector Plate	1				
37	0H03603B	Acrylic Cover Holder	5				
38	0H03607A	Lamp Cover Holder	2				
39	0B07768A	Lamp P.C.B.	1				
40	0B08466A	Lamp T3 12V 60mA	3				
41	0H03605B	Slide Volume Lamp Cover	1				
42	0H03606B	Acrylic Lamp House	3				
43	BA04012A	Lamp P.C.B. Ass'y 730	1				
44	0H03647A	Rubber Shade C	1				
45	0H03639C	Masking for Acrylic Cover	2				
*46	0M03983A	Power Switch Label	1				
47	0M03900A	Light Intercepting Seal	3				
48	0M03931A	Light Intercepting Seal R	1				
L01	0E00801A	Screw M2 x 5 Philips Pan Head (Bronze)	5				
L02	0E00787A	Screw M2 x 8 Philips Pan Head (Bronze)	2				
L03	0E00788A	BT Screw M2 x 8 Philips Pan Head (Bronze)	2				
L04	0E00594A	Screw M3 x 8 Philips Binding Head (Bronze)	3				
L05	0E00157A	Washer 3mm Plastics	3				

*: For UK only.

7.4. Front Panel Ass'y (B02)

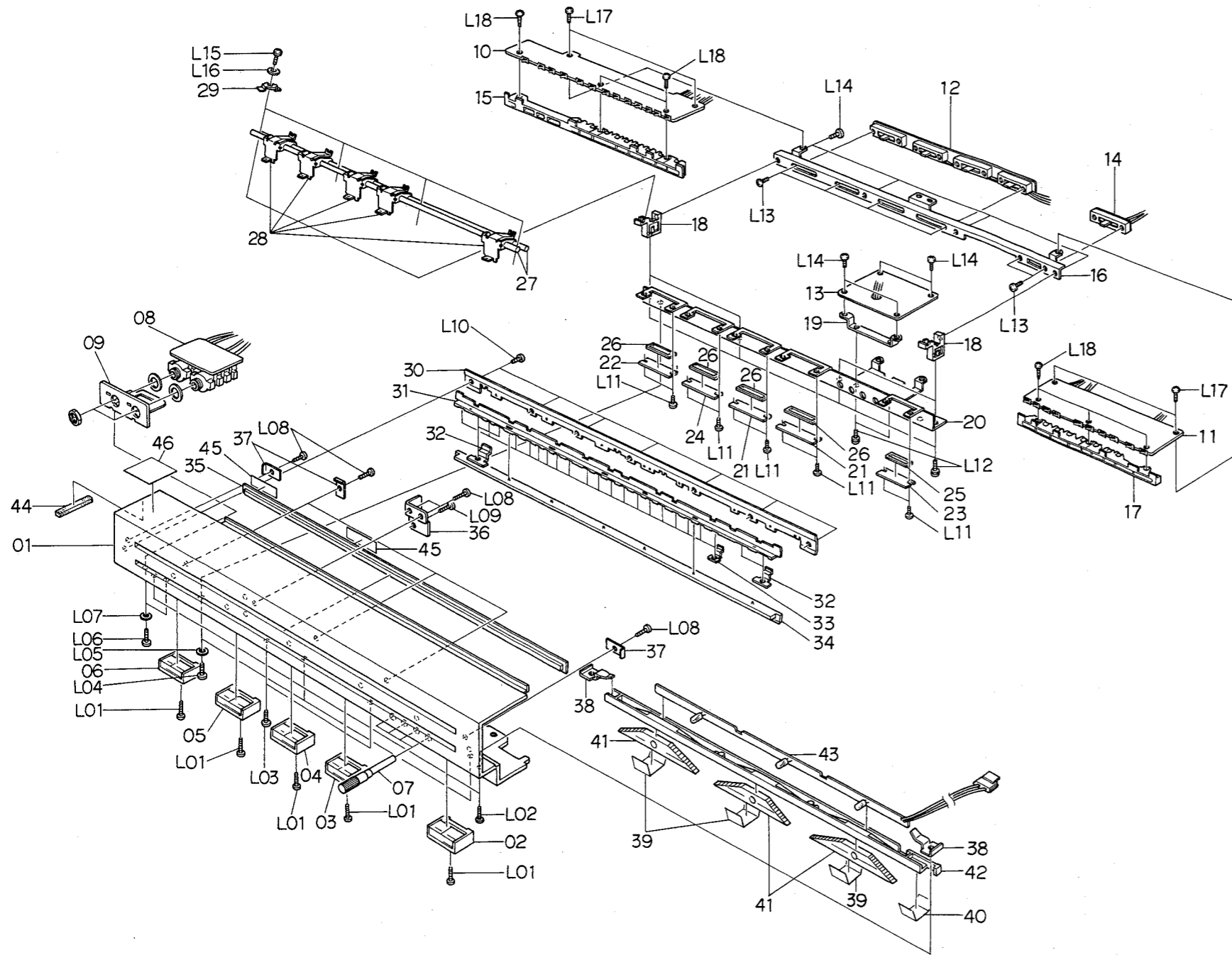

Fig. 7.4

7.5. Side Panel Ass'y 730 (B03)

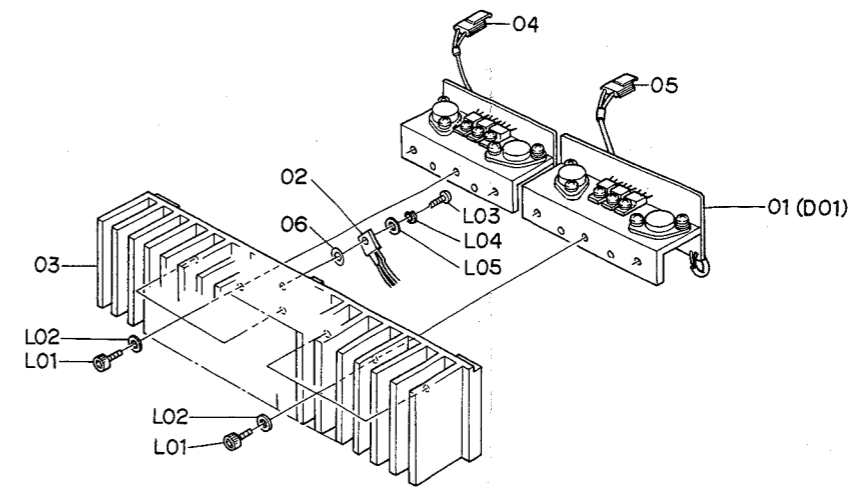

Fig. 7.5

7.6. Rear Panel Ass'y (B04)

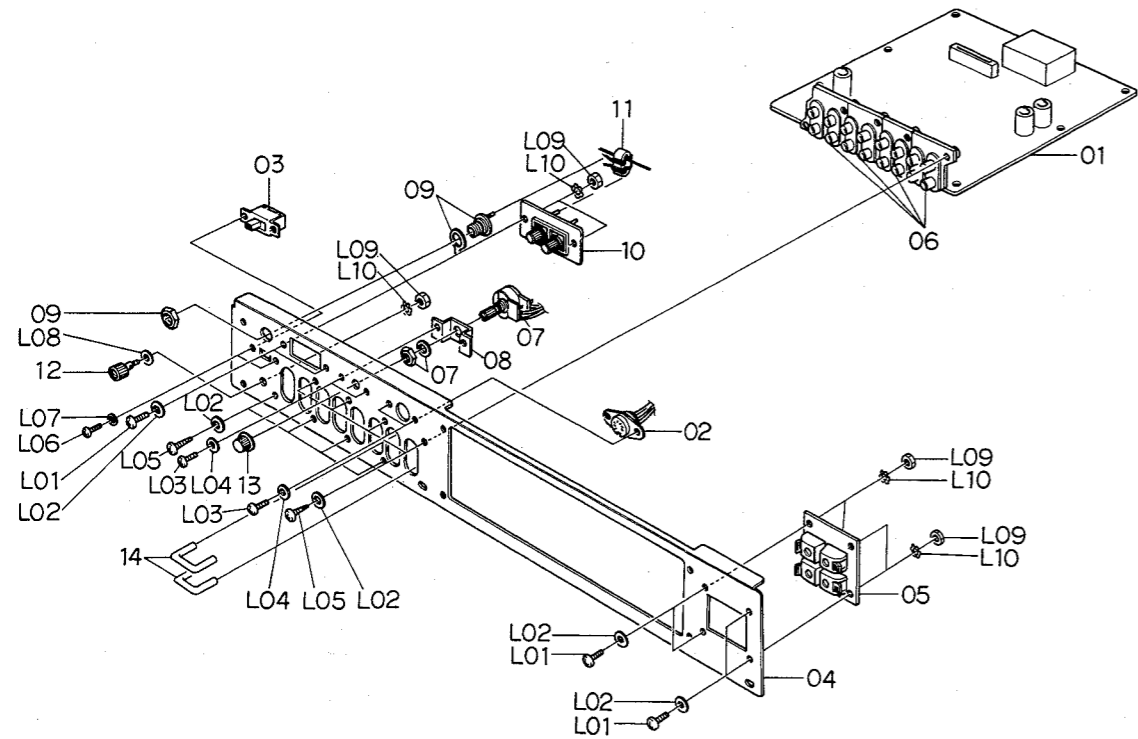

Fig. 7.6

7.7. Main Chassis Sub Ass'y (C01)

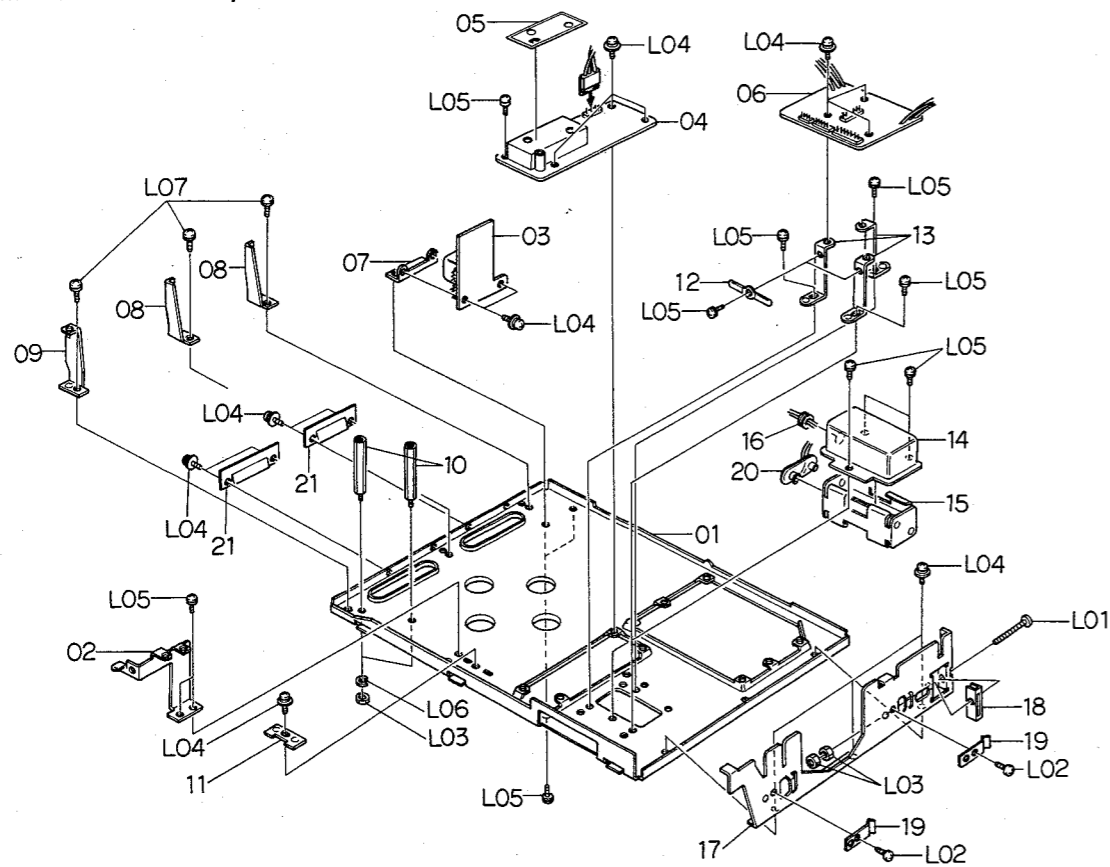

Fig. 7.7

Schematic Ref. No.	Part No.	Description	Q'ty	Schematic Ref. No.	Part No.	Description	Q'ty
B04	JA03280B	Rear Panel Ass'y	1	C02	JA03283B	Power Supply Ass'y (JAPAN)	1
01	BA03924A	Main P.C.B. Ass'y	1		JA03284A	Power Supply Ass'y (U.S.A.)	1
02	BA03940A	Remote Control Socket Ass'y	1		JA03285A	Power Supply Ass'y (CANADA)	1
03	BA03942A	Attenuator Switch Ass'y	1		JA03286A	Power Supply Ass'y (SWEDEN)	1
04	0J03826B	Rear Panel 730	1		JA03287A	Power Supply Ass'y (UK)	1
05	0B08497A	Push Terminal 730	1		JA03443A	Power Supply Ass'y (GERMANY)	1
06	0B08499A	4P Pin Jack	4		JA03324A	Power Supply Ass'y (AUSTRALIA)	1
07	0B07206A	Record Output Volume 20K (B)	1		JA03336A	Power Supply Ass'y (OTHERS)	1
08	0J03869A	Volume Holder	1	01	0J03832D	Power Box 730	1
09	0B08320A	Coaxial Connector	1	02	0B06606A	Power Transformer 100V	1
10	0B08309A	2P Terminal	1		0B06583A	Power Transformer 120V	1
11	0B06558A	Balun Transformer	1		0B06591A	Power Transformer 120V/220-240V	1
12	0B03920A	Ground Terminal	1	03	0B06584A	Power Transformer 220V/240V	1
13	0H03296B	Record Output Volume Knob	1		0B06585B	Sub Transformer 100V/120V	1
14	0D03617A	Pre-Main Connection Pin	2		0B06592A	Sub Transformer 120V/220-240V	1
L01	0E00594A	Screw M3 x 8 Philips Binding Head (Bronze)	6	04	0B06586A	Sub Transformer 220V/240V	1
L02	0E00157A	Washer 3mm Plastics	14	05	0B07221A	Power Relay	1
L03	0E00778A	Screw M2.6 x 5 Philips Binding Head (Bronze)	4	06	BA03944A	Capacitor P.C.B. Ass'y	1
L04	0E00651A	Washer 2.6mm Plastics	4		BA03931B	Power Supply P.C.B. Ass'y	1
L05	0E00766A	Screw M3 x 8 Philips Binding Head (Tapping)	8		BA04009A	Power Supply P.C.B. Ass'y (JAPAN)	1
L06	0E00804A	Screw M2 x 4 Philips Binding Head (Bronze)	2		BA04010A	Power Supply P.C.B. Ass'y (U.S.A. & CANADA)	1
L07	0E00805A	Washer 2mm Plastics	2	07	0J03836A	Power Supply P.C.B. Holder	1
L08	0E00732A	Washer 3mm	1	08	JA03289A	Power Panel Ass'y (JAPAN)	1
L09	0E00507A	Nut Hex. M3	7		JA03290A	Power Panel Ass'y (U.S.A.)	1
L10	0E00172A	Washer 3mm Toothed Lock	7		JA03291A	Power Panel Ass'y (CANADA)	1
C01	JA03440A	Main Chassis Sub Ass'y	1		JA03325A	Power Panel Ass'y (AUSTRALIA)	1
01	0J03819F	Main Chassis 730	1		JA03335A	Power Panel Ass'y (OTHERS)	1
02	0J03804B	Volume Control Holder (L)	1		JA03292A	Power Panel Ass'y (SWEDEN)	1
03	BA03918B	Protector P.C.B. Ass'y	1		JA03293A	Power Panel Ass'y (UK)	1
04	BA03930B	IF P.C.B. Ass'y	1	09	0J03878A	Bolt Receptacle Plate	4
05	0M03901A	IF Amp. Block Seal	1	10	0B07762A	Fuse P.C.B.	1
06	BA03921B	Tuning Logic P.C.B. Ass'y	1	11	0J03834B	Fuse P.C.B. Holder	1
07	0J03829A	Protector P.C.B. Holder	1	12	0J03887A	Protector P.C.B. Insulator	1
08	0J03821C	Side Panel Holder	2	13	0B08512A	Wire Holder A	2
09	0J03820B	Front Chassis Holder	1	14	0B08513A	Wire Holder B	3
10	0J03823B	VC Stud	2	15	0B08503A	Free Bushing 43mm	2
11	0J03824A	Adjust Plate	1	16	0B06085A	Diode Bridge S15VB-20	1
12	0B03067A	Wire Holder	2	* 1	0B08591A	Power Lamp Cord	1
13	0J03800C	P.C.B. Stud	3	* 2	0M03953A	Fuse Caution Label B	1
14	0J03817D	Battery Box	1	* 2	0M03954A	Fuse Caution Label C	1
15	0B08501A	Battery Holder	1	L01	0E00606A	Screw M3 x 6 Philips Pan Head (3A)	12
16	0J03871A	Rubber Grommet 9mm	1	L02	0E00607A	Screw M3 x 8 Philips Pan Head (3A)	4
17	0J03796E	Side Chassis R	1	L03	0E00797A	Nut Hex. M6	4
18	0J03799A	Side Plate Holder	1	L04	0E00798A	Washer 6mm Spring	4
19	0J03798B	Side Panel Hold Spring	2	L05	0E00799A	Washer 8mm	4
20	0B05200A	Battery Snap	1	L06	0E00807A	Screw M4 x 16 Philips Pan Head (2A)	1
21	0J03822A	Power Block P.C.B. Insulator	2				
L01	0E00780A	Screw M4 x 30 Philips Pan Head	1				
L02	0E00522A	Screw M3 x 4 Philips Pan Head	2				
L03	0E00506A	Nut Hex. M4	4				
L04	0E00606A	Screw M3 x 6 Philips Pan Head (3A)	16				
L05	0E00612A	Screw M3 x 6 Philips Pan Head (2A)	13				
L06	0E00574A	Washer 4mm Spring	2				
L07	0E00664A	Screw M4 x 8 Philips Pan Head (2A)	3				

* 1: For UK & Sweden only.
* 2: For U.S.A. & Canada only.

7.8. Power Supply Ass'y (C02)

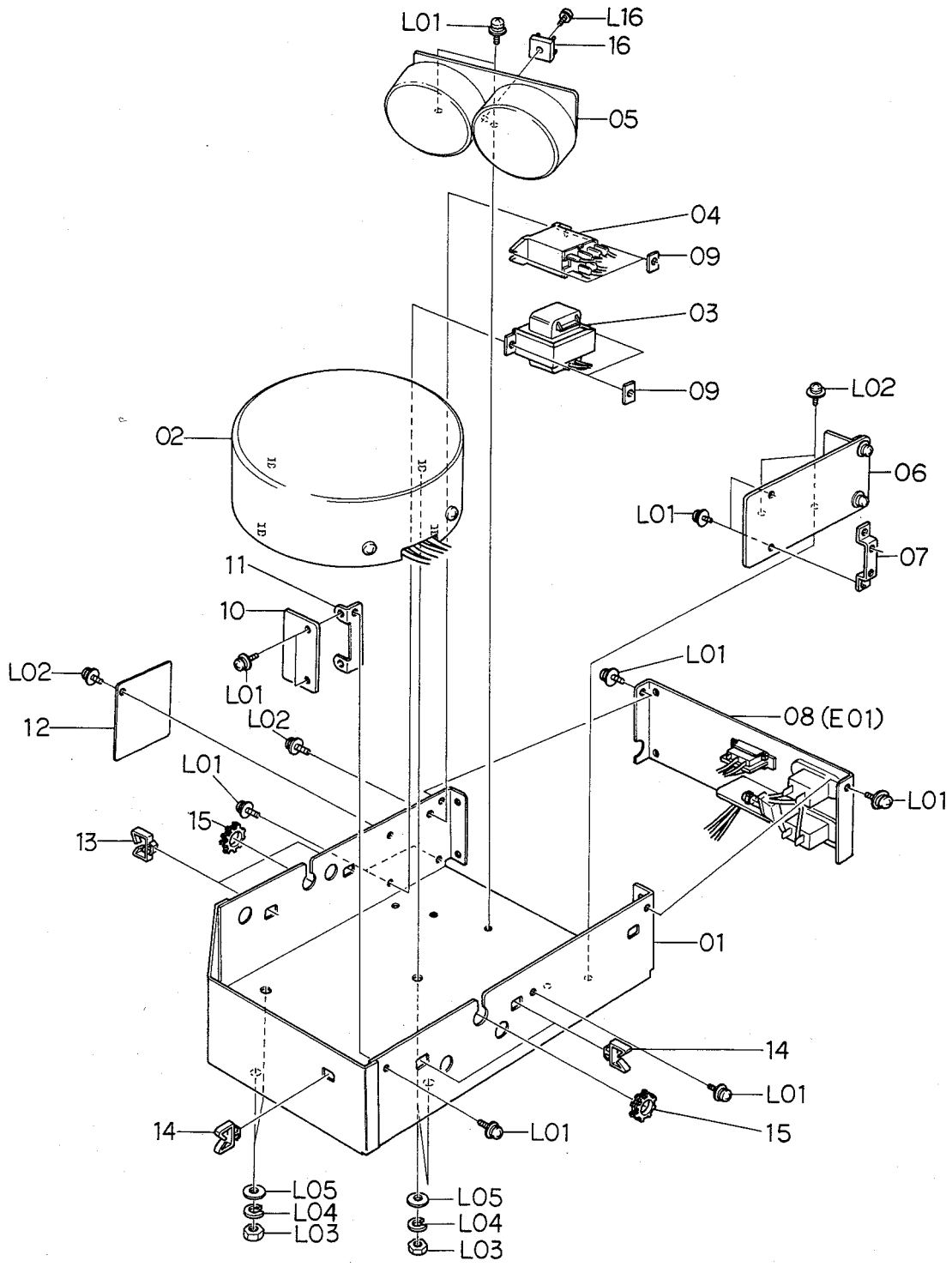

Fig. 7.8

7.9. Volume Control Ass'y (C03)

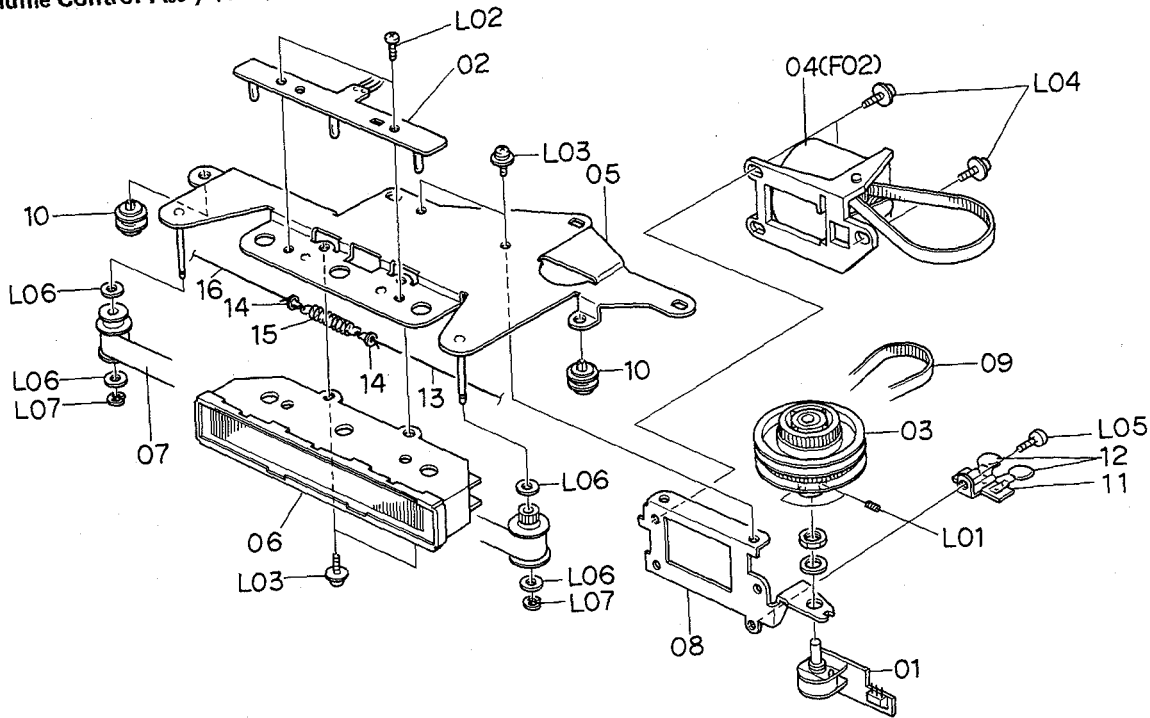

Fig. 7.9

Schematic Ref. No.	Part No.	Description	Q'ty	Schematic Ref. No.	Part No.	Description	Q'ty
C03	JA03277A	Volume Control Ass'y	1	C04	JA03268A	Front-end Control Ass'y	1
					JA03323A	Front-end Control Ass'y (JAPAN)	1
01	BA03925A	Volume P.C.B. Ass'y	1	01	JA03260A	Motor Base Ass'y (Front-end)	1
02	BA03926A	Volume Lamp P.C.B. Ass'y	1	02	JA03261A	Front-end Reel Ass'y	1
03	JA03263A	Volume Clutch Ass'y	1	03	0B08459A	Front-end 730	1
04	JA03264A	Motor Base Ass'y (Volume)	1		0B08460A	Front-end 730 (JAPAN)	1
05	JA03265A	Volume Control Base Ass'y	1	04	0J03795C	Front-end Base	1
06	JA03266A	Lighting Case Ass'y	1	05	0J03897A	Pulley Holder	1
07	JA03312A	Mylar Mask Ass'y	1	06	JA03315A	Pulley Ass'y 730	2
08	0J03899A	Base Holder A	1	07	0B03067A	Wire Holder	1
09	0J03846A	Timing Belt 80083	1	L01	0E00785A	Screw M3 x 4 Cup Point Hex. Socket Head	2
10	JA03315A	Pulley Ass'y 730	2	L02	0E00607A	Screw M3 x 8 Philips Pan Head (3A)	3
11	0B04042A	Lug Terminal 1L2P	1	L03	0E0606A	Screw M3 x 6 Philips Pan Head (3A)	2
12	0B09091A	Ceramic Capacitor 0.01μ 25V	2				
13	0J04005A	Volume Thread A 330mm	1				
14	0E00752A	Thread Guide	2				
15	0J03862A	Spring LV	1				
16	0J04006A	Volume Thread B 400mm	1				
L01	0E00785A	Screw M3 x 4 Cup Point Hex. Socket Head	2	C05	HA03755A	Lamp Base Ass'y	1
L02	0E00124A	Screw M2 x 4 Philips Pan Head (2A)	2	01	0H03613C	Lamp Base	1
L03	0E00606A	Screw M3 x 6 Philips Pan Head (3A)	4	02	0H03615C	Lamp House	1
L04	0E00607A	Screw M3 x 8 Philips Pan Head (3A)	3	03	0H03616A	Orange Lens	1
L05	0E00522A	Screw M3 x 4 Philips Pan Head (2A)	1	04	0H03614B	Green Lens	1
L06	0J03845A	Washer 7.8-3.1-0.25	4	05	0B07781B	Tuning Lamp P.C.B.	1
L07	0E00222A	E-Ring 2mm	2	06	0B08466A	Lamp T3 12V 60mA	3
				07	0B08480A	4P-H Connector Ass'y	1
				08	0J03809A	Wire Stopper	1
				09	0J03865A	Lamp P.C.B. Cover	1
				L01	0E00793A	BT Screw M2 x 6 Philips Pan Head	2

7.10. Front-end Control Ass'y (C04)

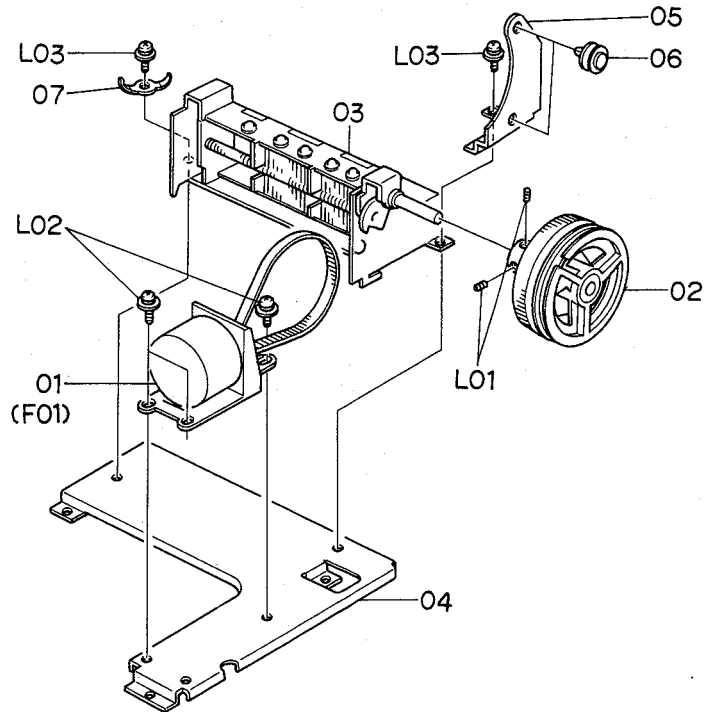

Fig. 7.10

7.11. Lamp Base Ass'y (C05)

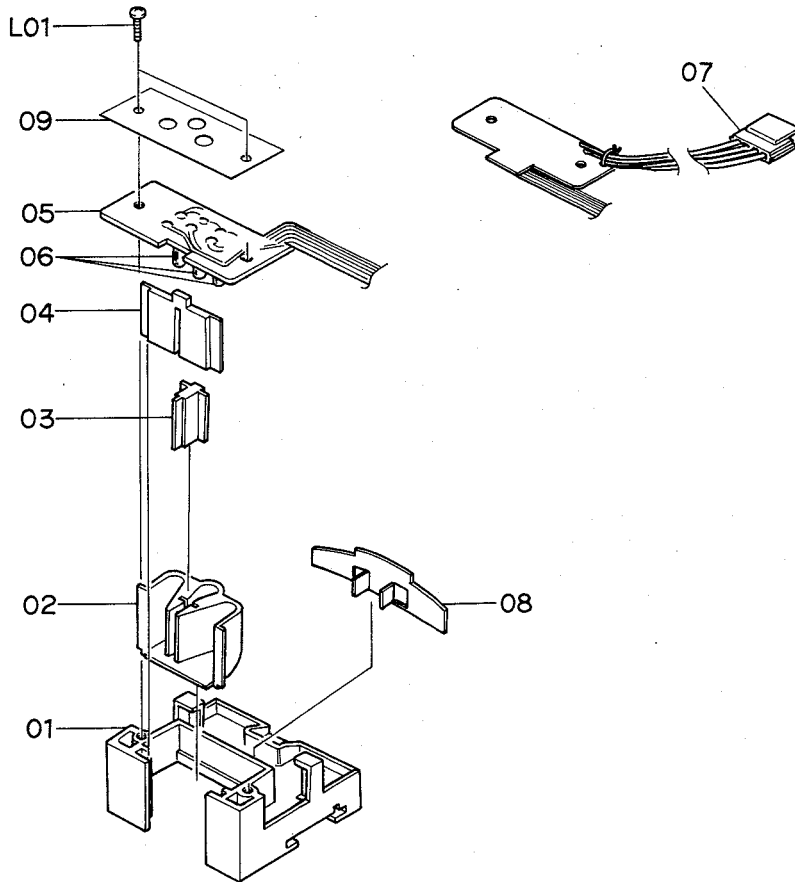

Fig. 7.11

7.12. Power Block Ass'y 730 (D01)

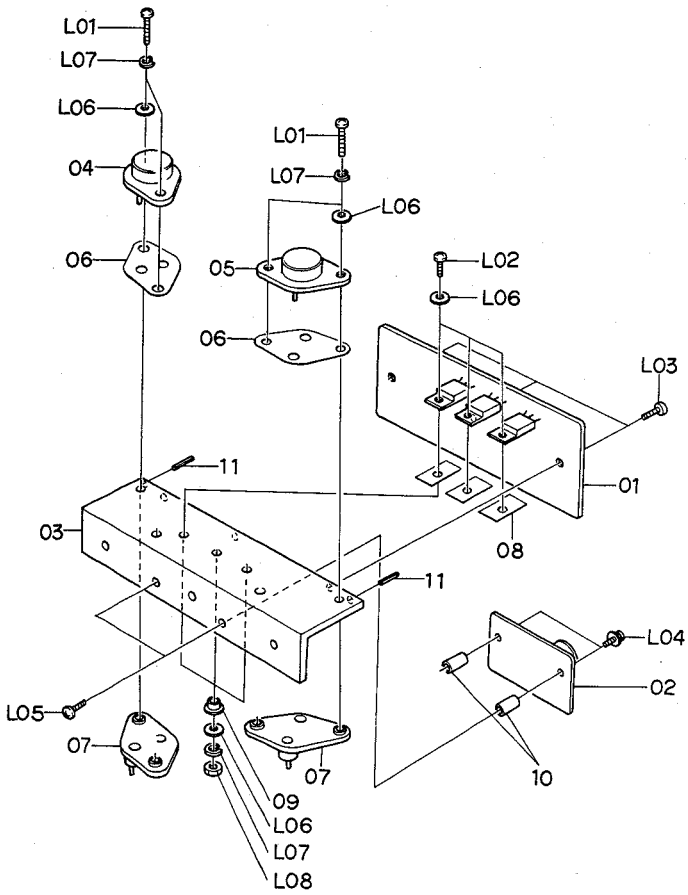

Fig. 7.12

7.14. Motor Base Ass'y (Front-end) (F01) and Motor Base Ass'y (Volume) (F02)

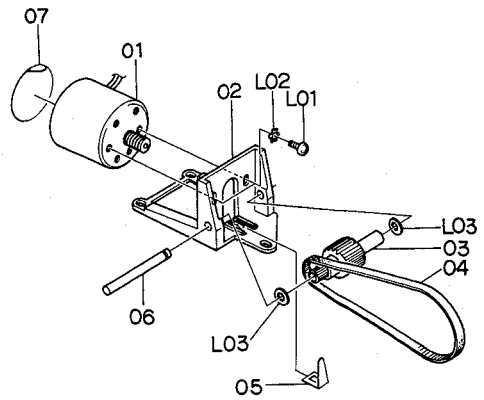

Fig. 7.14

7.13. Power Panel Ass'y (E01)

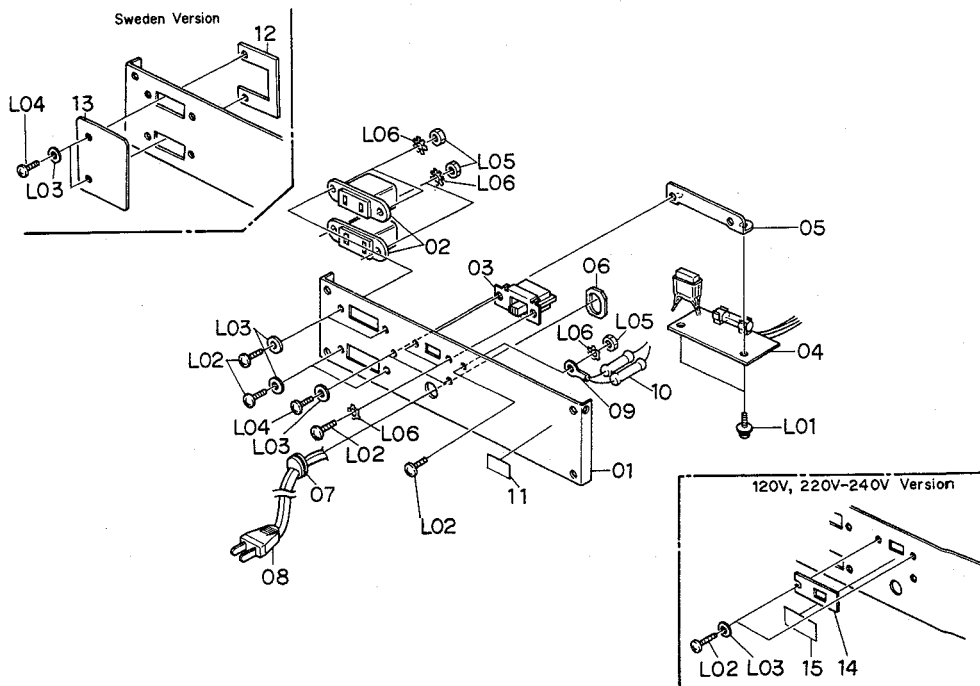
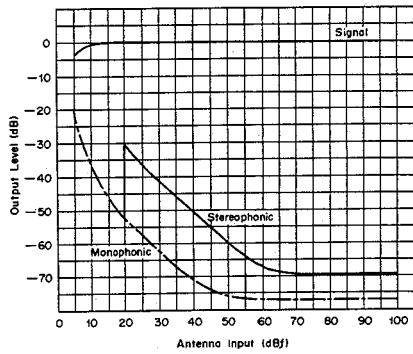

Fig. 7.13

Schematic Ref. No.	Part No.	Description	Q'ty	Schematic Ref. No.	Part No.	Description	Q'ty
D01	JA03282B	Power Block Ass'y 730	1	08	0B08219B	Power Cord (JAPAN)	1
01	BA03932B	Power Amp. P.C.B. Ass'y	1		0B08504A	Power Cord	1
02	BA03929A	Output P.C.B. Ass'y	1		0B08266U	Power Cord	1
03	0J03830A	Heat Sink 730	1			(UK & AUSTRALIA)	
04	0B06081A	Transistor 2SB600	1		0B08149U	Power Cord (SWEDEN)	1
05	0B06083A	Transistor 2SD555	1		0B08093U	Power Cord (GERMANY)	1
06	0B08596A	Insulator Mica TO3	1	09	0E00037A	Earth Lug B5	1
07	0B08498A	Transistor Socket	2	10	0B05928A	Metal Film Resistor 3.9M	2
08	0B08532A	Insulator Mica TO220	3			ER0-50CDG (JAPAN, U.S.A. & CANADA)	
09	0B08531A	Transistor Bushing 25K	3	11	0M03794A	Voltage Label 100V (JAPAN)	1
10	0J03831A	Output P.C.B. Stud	2		0M03795A	Voltage Label 120V (U.S.A. & CANADA)	1
11	0J03560A	Spring Pin	2		0M03797A	Voltage Label 240V (UK & AUSTRALIA)	1
L01	0E00871A	Screw M3 x 18 Philips Binding Head	4		0M03796A	Voltage Label 220V (SWEDEN & OTHERS)	1
L02	0E00741A	Screw M3 x 12 Philips Binding Head	3		0M03955A	Voltage Label 120V/220-240V	1
L03	0E00231A	FT Screw M2.6 x 8 Philips Pan Head	3	12	0J03552A	Bolt Receptacle Plate for Relay (SWEDEN)	1
L04	0E00606A	Screw M3 x 6 Philips Pan Head (3A)	2	13	0J03910A	Cover Plate (SWEDEN)	1
L05	0E00502A	Screw M3 x 5 Philips Pan Head	2	14	0M03948A	Voltage Lock Plate D 120V/220-240V	1
L06	0E00732A	Washer 3mm	8	15	0M03949A	Voltage Label 730 120V/220-240V	1
L07	0E00723A	Washer 3mm Spring	7		0M03798A	Nakamichi Label (JAPAN)	1
L08	0E00718A	Nut Hex. M3	3		0M03952A	Fuse Caution Label A (U.S.A. & CANADA)	1
E01	JA03289A	Power Panel Ass'y (JAPAN)	1		0M03700A	Earth Label (UK)	1
	JA03290A	Power Panel Ass'y (U.S.A.)	1		0M03981A	Power Consumption Label (U.S.A. & CANADA)	1
	JA03291A	Power Panel Ass'y (CANADA)	1	L01	0E00606A	Screw M3 x 6 Philips Pan Head (3A)	2
	JA03325A	Power Panel Ass'y (AUSTRALIA)	1	L02	0E00594A	Screw M3 x 8 Philips Binding Head (Bronze)	7
	JA03335A	Power Panel Ass'y (OTHERS)	1	L03	0E00157A	Washer 3mm Plastics	6
	JA03292A	Power Panel Ass'y (SWEDEN)	1	L04	0E00593A	Screw M3 x 6 Philips Binding Head (Bronze)	2
	JA03293A	Power Panel Ass'y (UK)	1	L05	0E00507A	Nut Hex. M3	5
	JA03444A	Power Panel Ass'y (GERMANY)	1	L06	0E00172A	Washer 3mm Toothed Lock	7
01	0J03833B	Power Supply Panel	1	F01	JA03260A	Motor Base Ass'y (Front-end)	1
	0J03909B	Power Supply Panel (UK)	1	F02	JA03264A	Motor Base Ass'y (Volume)	1
02	0B08162U	AC Outlet	2	01	JA03267A	Motor Ass'y 730	1
	0B08510A	AC Outlet (U.S.A. & CANADA)	2	02	0J03852A	Motor Base	1
	0B08356A	AC Outlet (UK)	1	03	0J03854A	Motor Base Gear	1
03	0B07092A	Power Switch	1	04	0J03853A	Timing Belt 80095 (Front-end)	1
	0B07092A	Voltage Selector Switch 120V/220-240V	1		0J03902A	Timing Belt 80071 (Volume)	1
	0B07172A	Power Switch (U.S.A. & CANADA)	1	05	0J03855B	Motor Base Spring	1
04	BA04005A	Fuse P.C.B. Ass'y (JAPAN)	1	06	0J03839A	Shaft	1
	BA04006A	Fuse P.C.B. Ass'y (U.S.A. & CANADA)	1	07	0M03902A	Motor Label 730	1
	BA04007A	Fuse P.C.B. Ass'y (SWEDEN)	1	L01	0E00219A	Screw M2.6 x 5 Philips Pan Head	2
	BA04008A	Fuse P.C.B. Ass'y (AUSTRALIA, UK & OTHERS)	1	L02	0E00233A	Washer 2.6mm Toothed Lock	2
	BA04011A	Fuse P.C.B. Ass'y 120V/220-240V	1	L03	0J03845A	Washer 7.8-3.1-0.2S	2
05	0J03834B	Fuse P.C.B. Holder	1				
06	0A03154B	Cord Spacer	1				
07	0B08037U	Cord Bushing C (JAPAN & GERMANY)	1				
	0B08351A	Cord Bushing	1				
	0B08325U	Cord Bushing (UK & AUSTRALIA)	1				
	0B08325A	Cord Bushing (SWEDEN)	1				

8. PERFORMANCE DATA

Tuner Section



Input vs. Noise Level

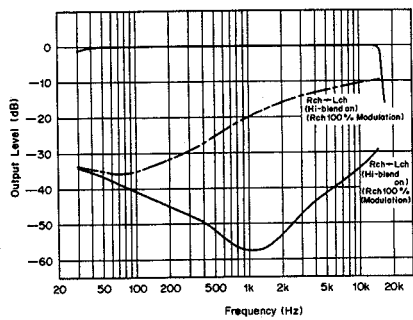

Stereo Separation
Antenna Input: 98 MHz, 65 dBf, 1 mV, 300 Ω

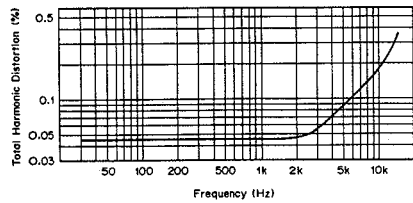

Frequency vs. Total Harmonic Distortion
Antenna Input: 98 MHz, 65 dBf, 1 mV, 300 Ω
Modulation: Main 45.5%
Sub-carrier 45.5%
Pilot 9%

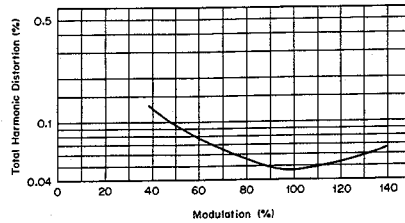

Modulation vs. Total Harmonic Distortion
Modulation: Main 45.5%
Sub-carrier 45.5%
Pilot 9%
Frequency: 1 kHz
Antenna Input: 98 MHz, 65 dBf, 1 mV, 300 Ω

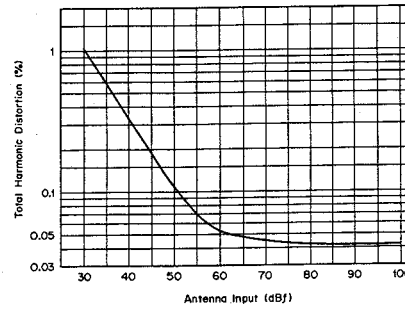

Input vs. Total Harmonic Distortion (Stereo)
Antenna Input: 98 MHz, 1 mV, 300 Ω
Modulation: Main 45.5%
Sub-carrier 45.5%
Pilot 9%

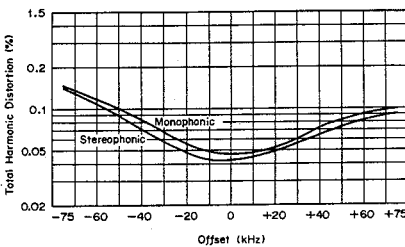

Tuning vs. Total Harmonic Distortion
Antenna Input: 98 MHz, 65 dBf, 1 mV, 300 Ω
Modulation: Main 45.5%
Sub-carrier 45.5%
Pilot 9%

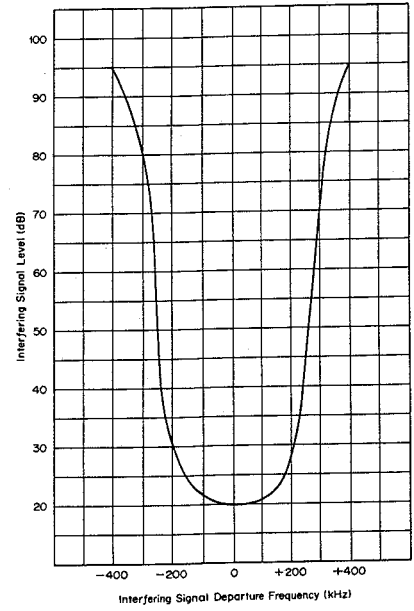

Channel Selectivity
Impedance: 300 Ω
Interfering Signal: 1 kHz, 100 % Modulation
Interference Output Level: -30 dB
Desired Signal: Unmodulated

Fig. 8.1

Amplifier Section

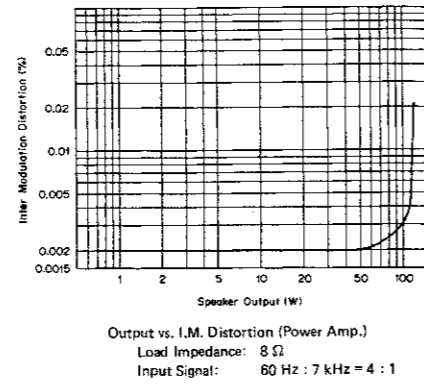
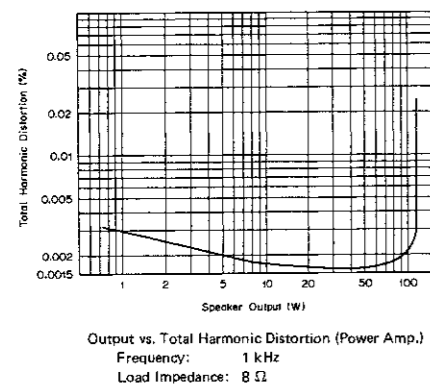
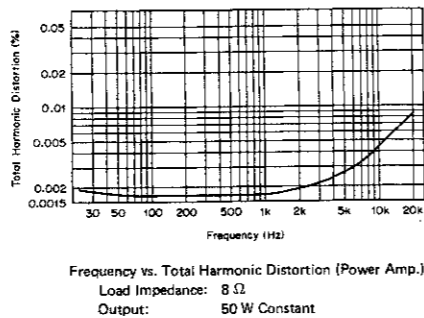
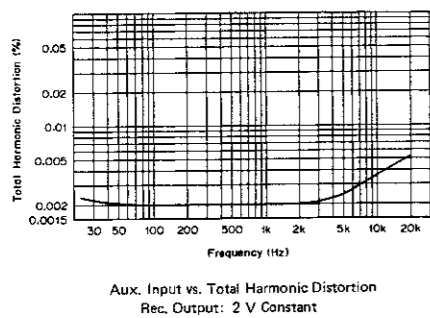
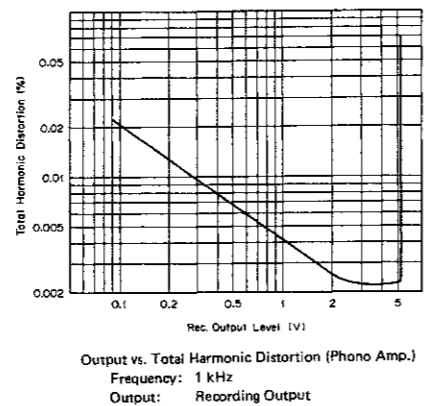
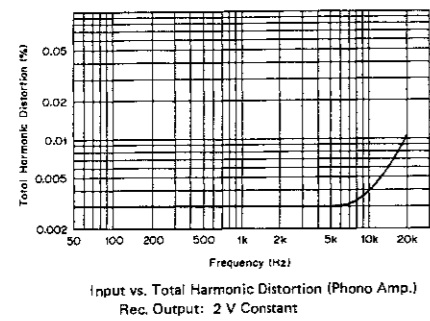

Fig. 8.2

9. BLOCK DIAGRAMS

9.1. Tuner Section

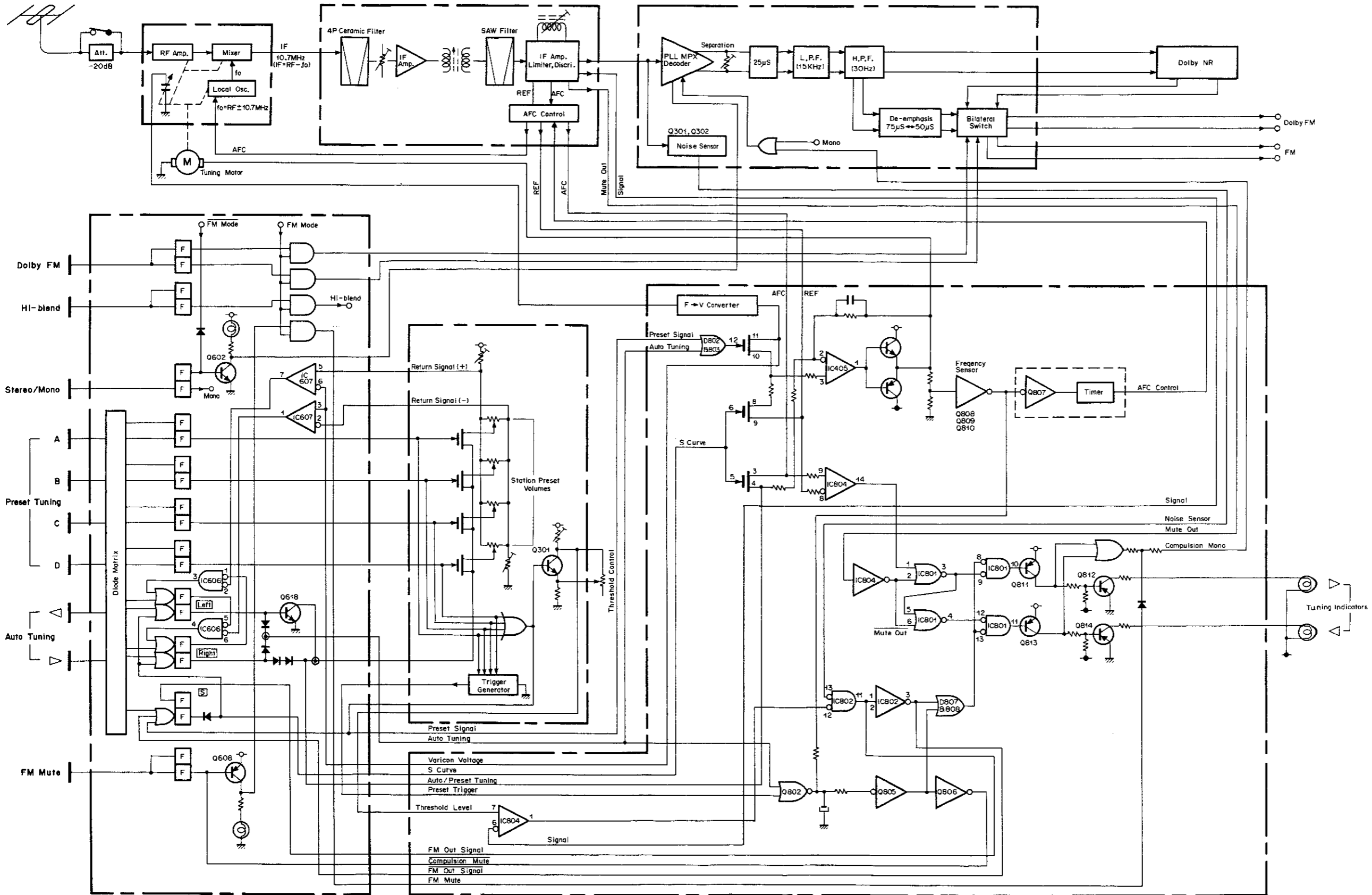

Fig. 9.1

9.2. Amplifier Section

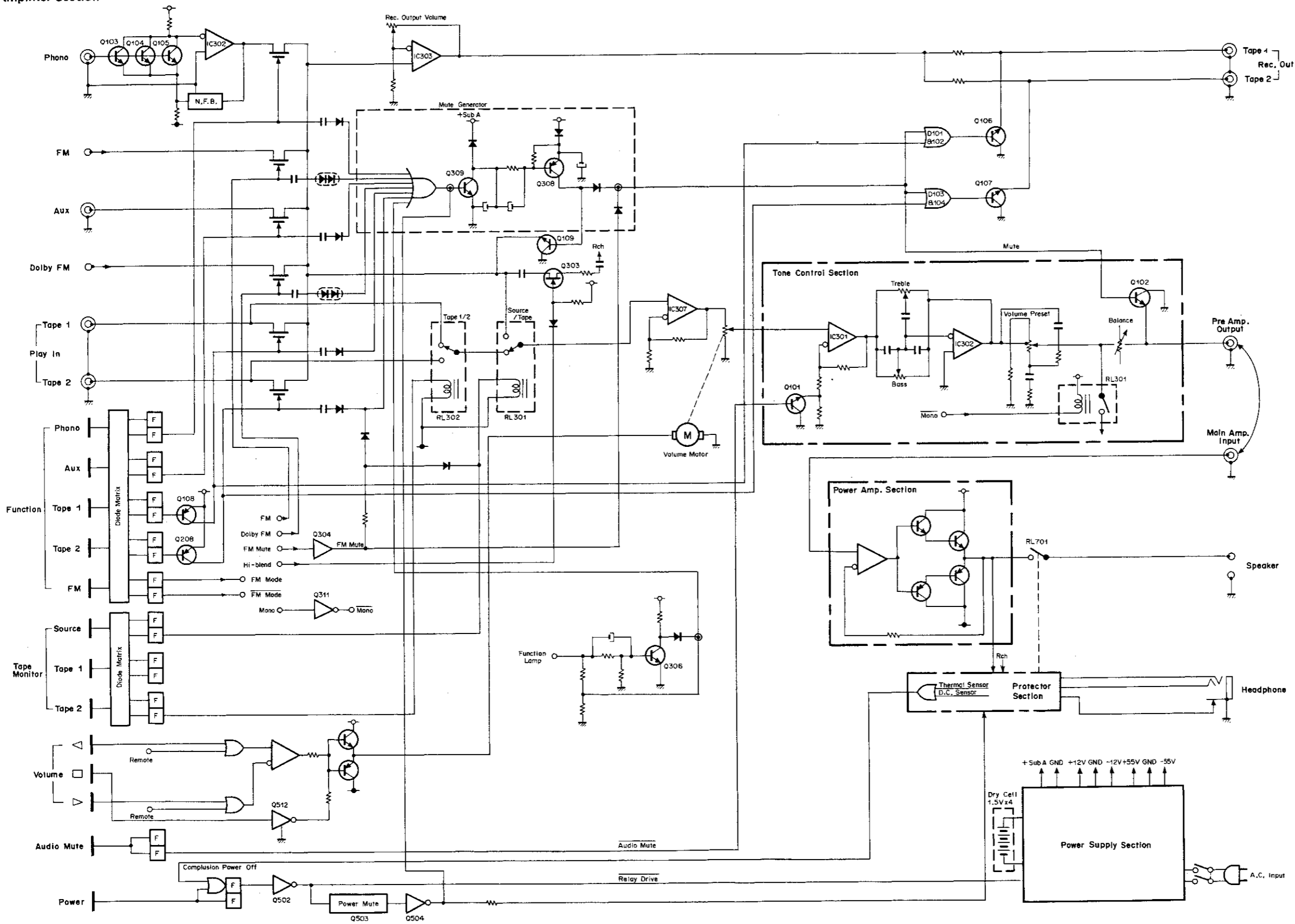

Fig. 9.2

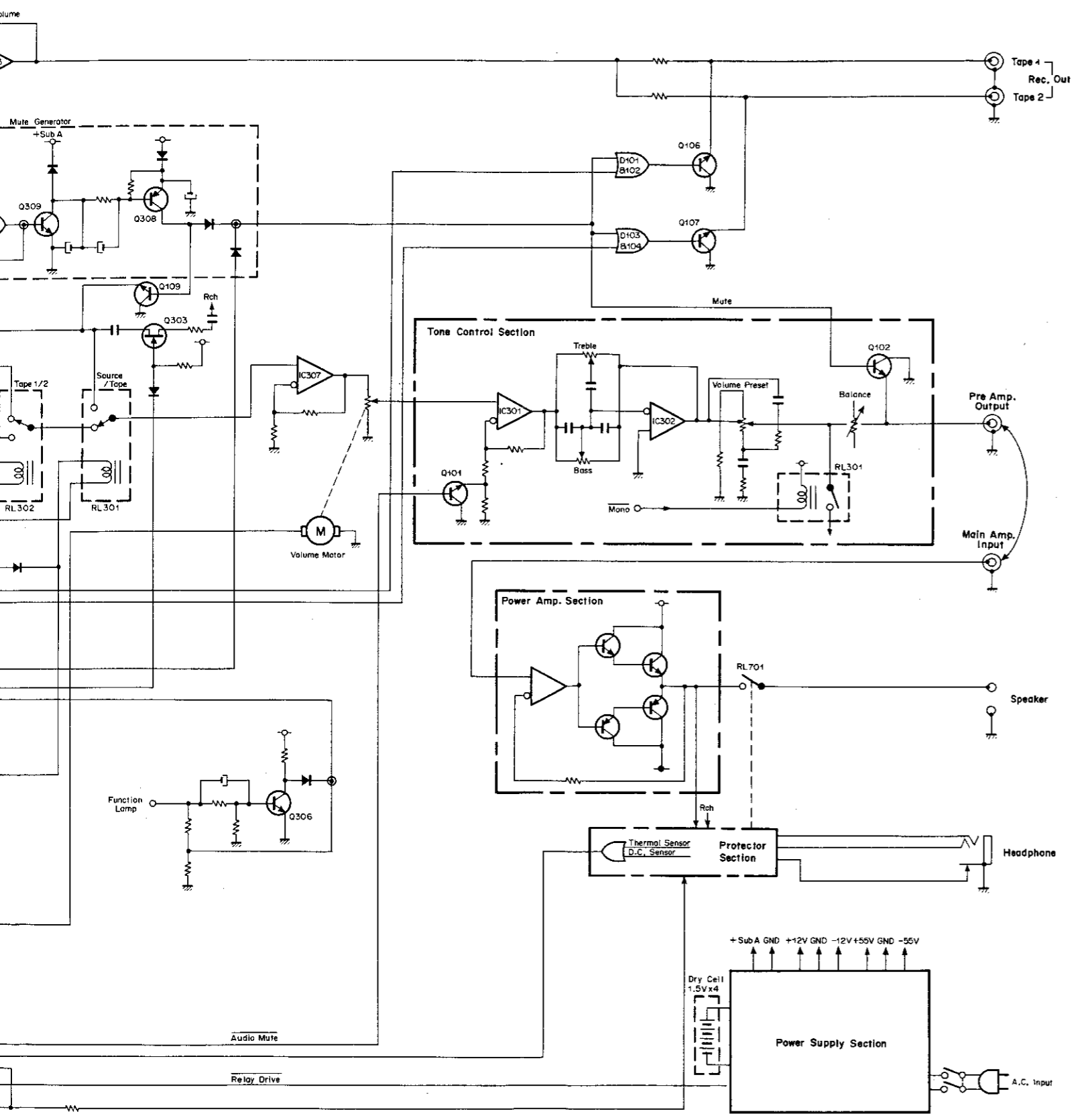

Fig. 9.2

10. SCHEMATIC DIAGRAMS

Note: Refer to notes and diagrams of ICs on page 81.

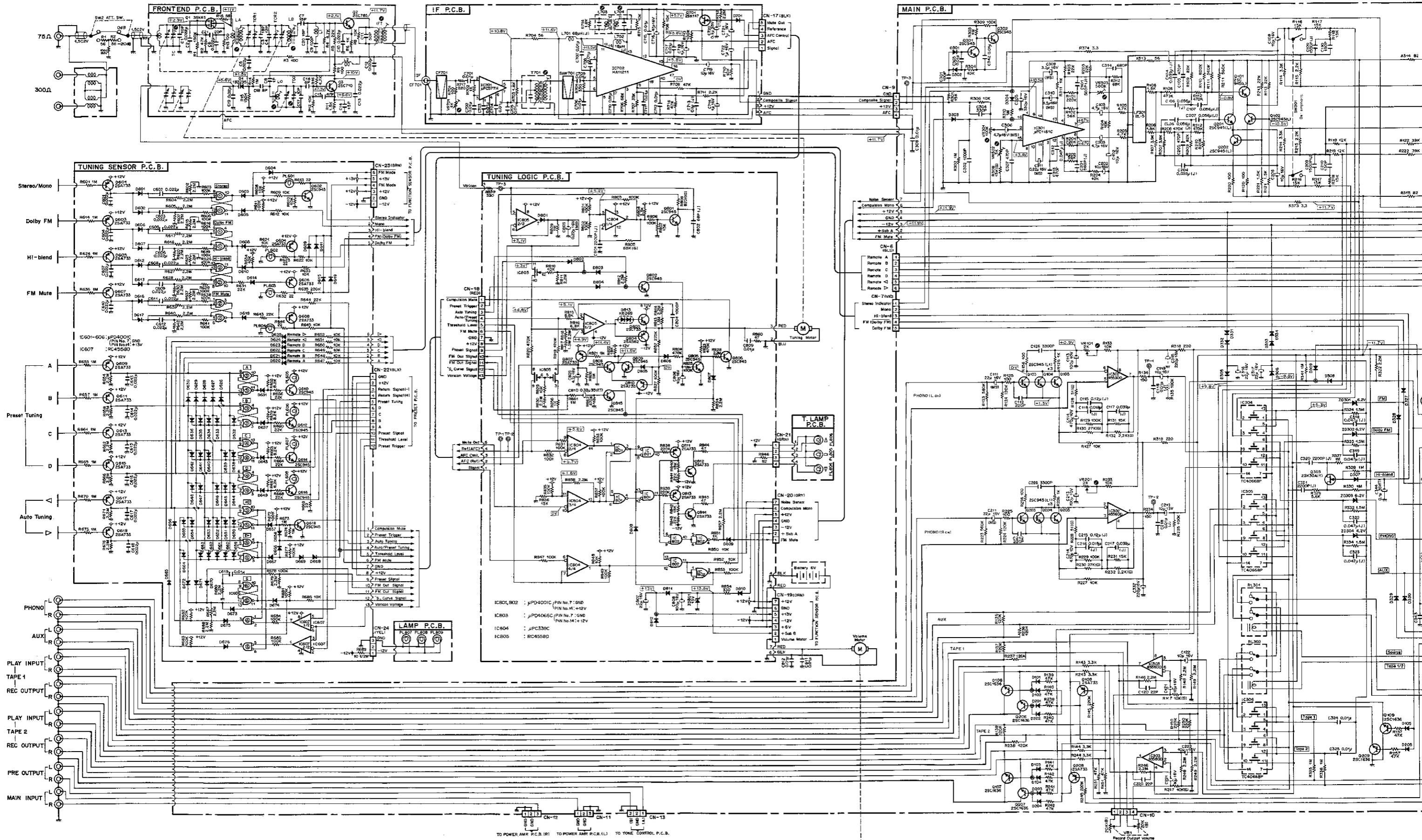

Fig. 10.1

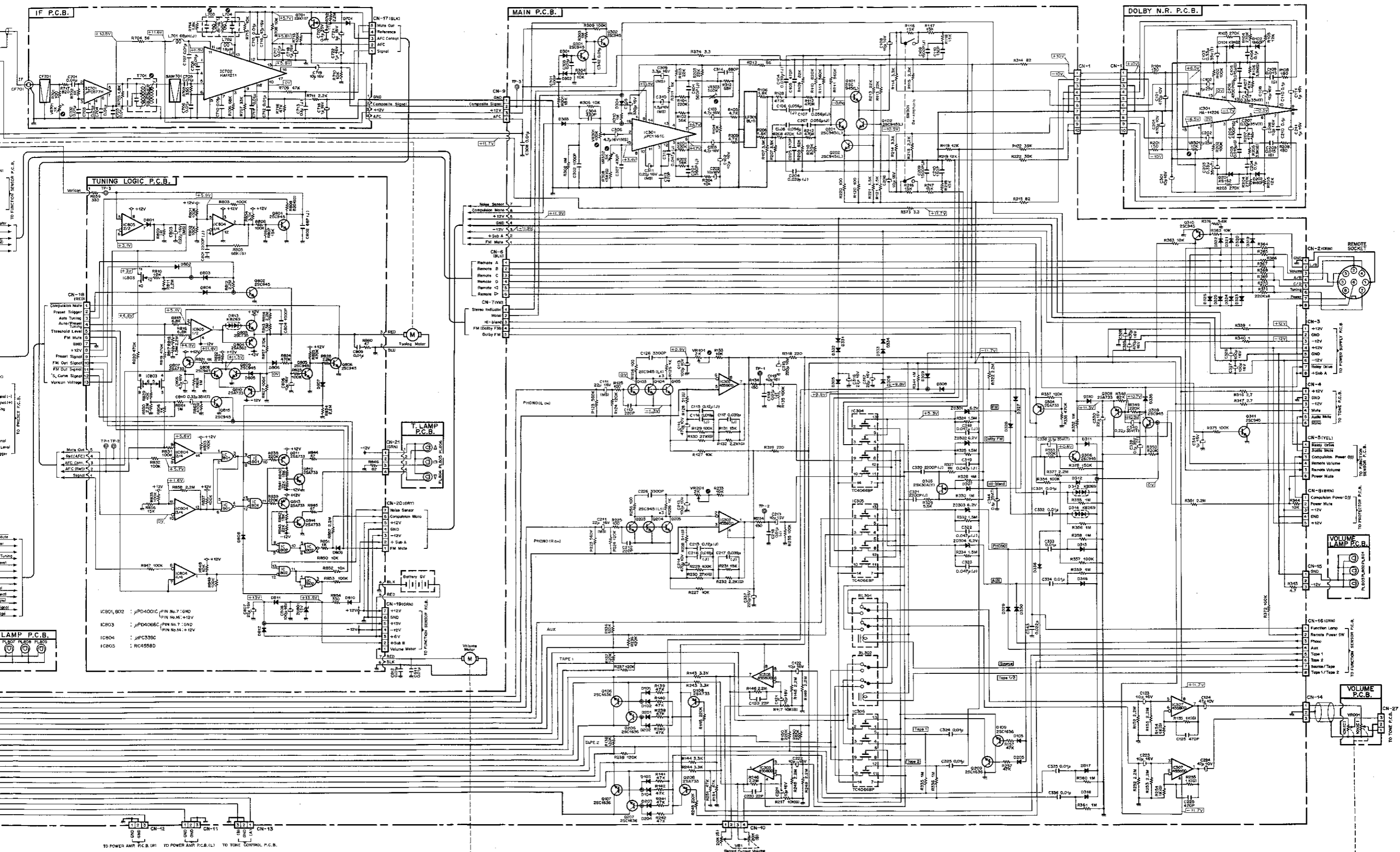

Fig. 10.1

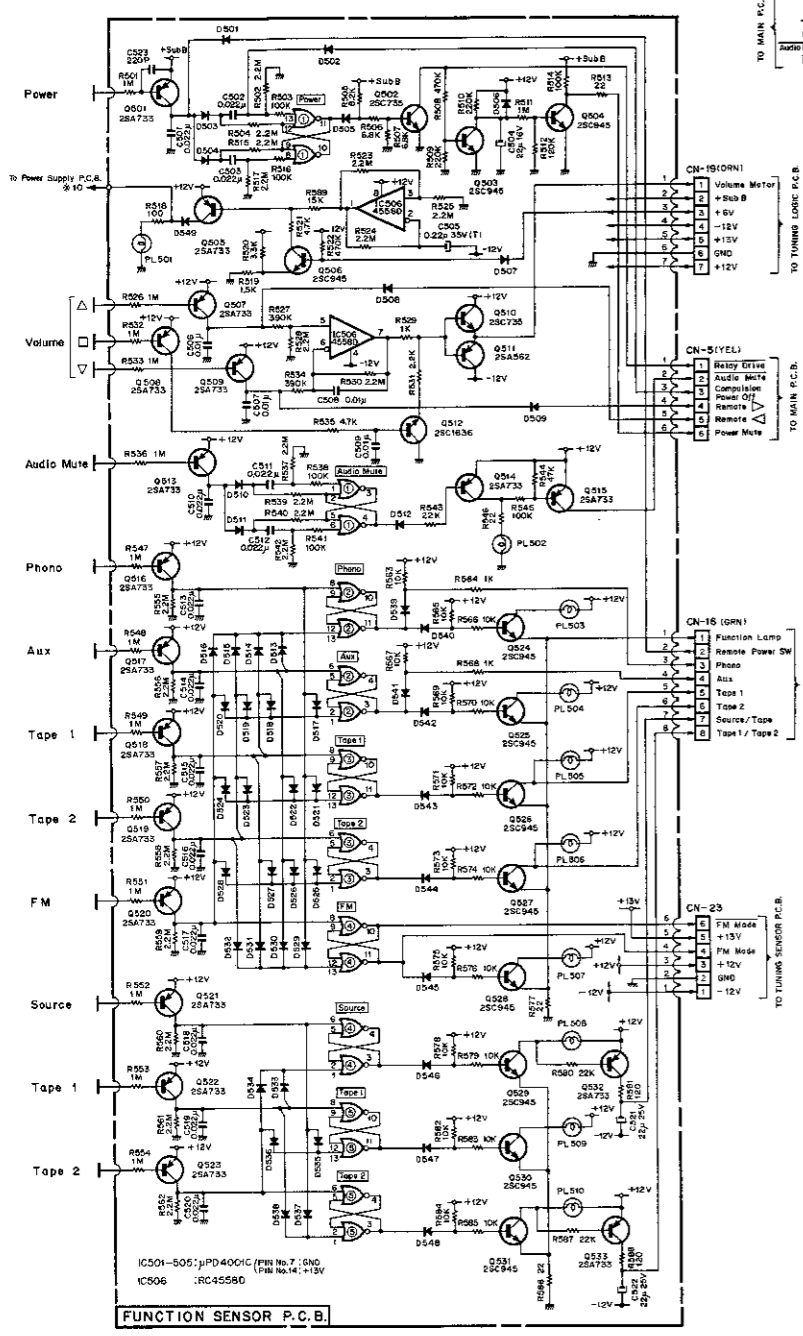
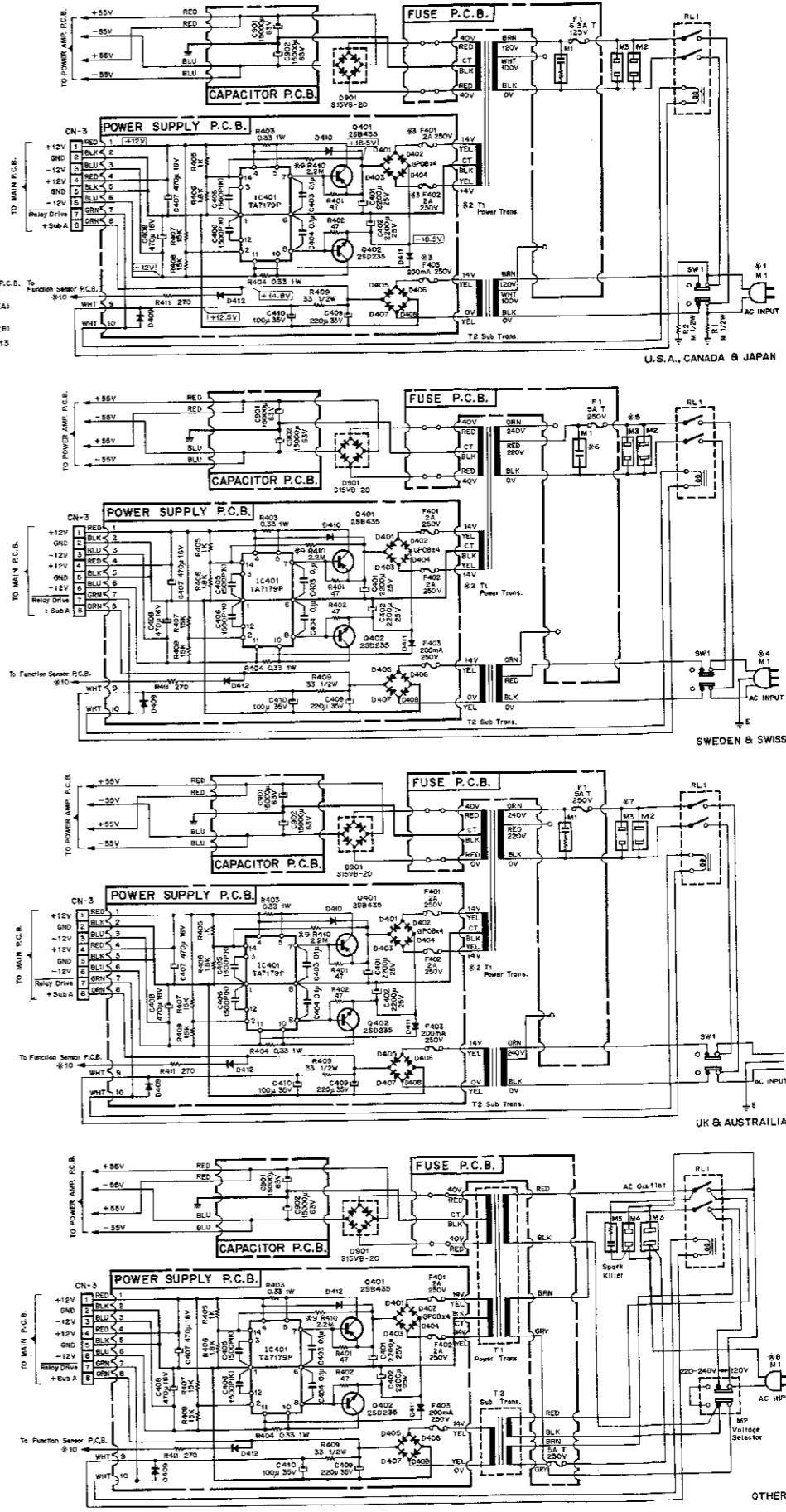
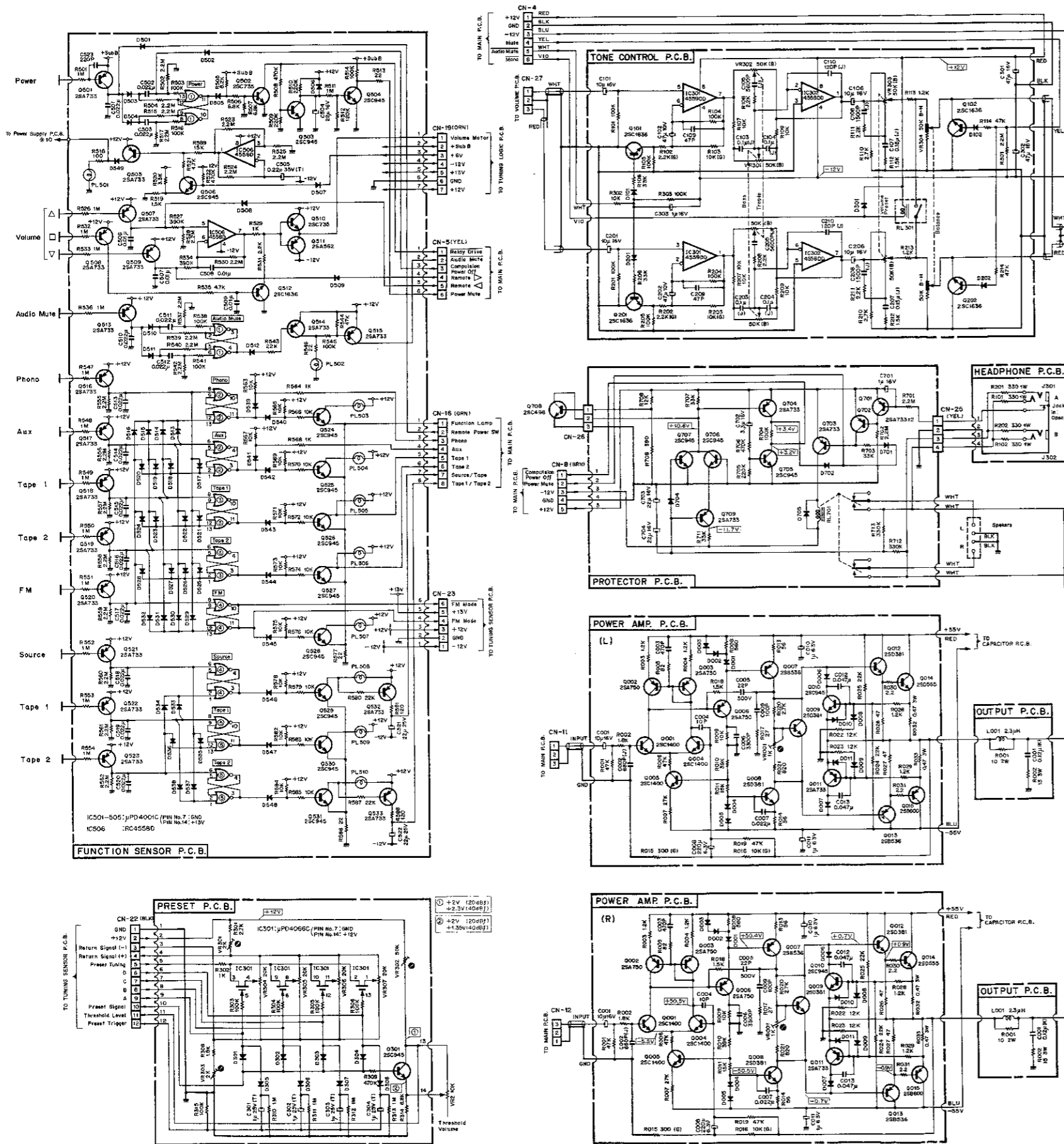

Fig. 10.2

General Notes :

1. Reference voltage in the circuit shows the voltage at the following condition:
Function – FM mode
Frequency – 90 MHz, tuned by Auto-tuning
Wattage – Approx. 50 watts (8-ohm) output per channel
2. Diode is 1S1555 unless otherwise specified.
3. In the Function Sensor P.C.B. Ass'y, Nos. 1 – 5 of C-MOS IC indicate IC501 – IC505.
In the Tuning Sensor P.C.B. Ass'y, Nos. 1 – 6 of C-MOS IC indicate IC601 – IC606.
No. 14 pin of the C-MOS IC is connected to +13 V and No. 7 pin is grounded.
4. On the Main P.C.B., Tone Control P.C.B., Headphone P.C.B., Output P.C.B. and Dolby NR P.C.B., part reference Nos. 100 – 199 show L channel's parts and 200 – 299 show R channel's parts. For example, R101 is an L channel's resistor and R201 is an R channel's resistor.
5. On the Main P.C.B., Tone Control P.C.B., Headphone P.C.B. and Dolby NR P.C.B., part reference Nos. 300 – 399 show common parts for both channels.

Notes for Power Supply Section:

- *1. Power Cord: U.S.A. and Canada versions are the same, but Japan version is different.
- *2. Power Transformer: U.S.A. and Canada versions are the same (as shown in the diagram), but Japan version is different (only terminals of 100 V and 0 V are provided at the primary side).
- *3. Fuse: U.S.A. and Canada versions are the same, but Japan version uses different type.
- *4. Power Cord: For Sweden version, 3-core cord is used, but 2-core cord is used for Swiss version.
- *5. AC Outlets: 2 Outlets of U.S.A. type are incorporated only for Swiss version.
- *6. Spark Killer: For Sweden version, capacitor type is used, but capacitor and resistor combination type is used for Swiss version.
- *7. AC Outlets: For UK version, one Outlet of BS type is used, but 2 Outlets of U.S.A. type are used for Australia version.
- *8. Power Cord: Only for Germany version 2-core with Euro-Plug is used but U.S.A. type is used for other versions.
- *9. Resistor for Adjustment: R410 2.2 MΩ in the Power Supply P.C.B. Ass'y is a resistor for adjustment (value will be changed or resistor will be removed). 2.2 MΩ is a typical value.
- *10. Stand-by Indication: For UK and Sweden versions, when Master Power Switch at the Rear Panel is switched ON (with AC Power Cord plugged in), stand-by condition is indicated by the Power Lamp even if Power ON is not touch-commanded by the Power Sensor at the Front Panel. For this reason, one extra signal wire is connected to Function Sensor P.C.B. Ass'y from Power Supply P.C.B. Ass'y.

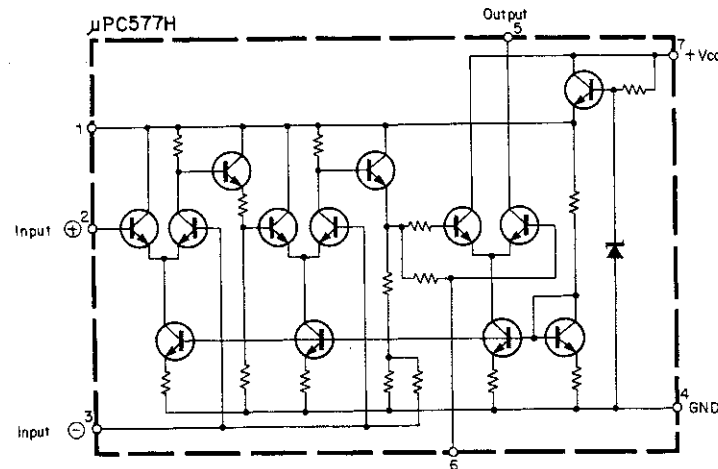

Fig. 10.3 FM IF Amp. IC μPC577H

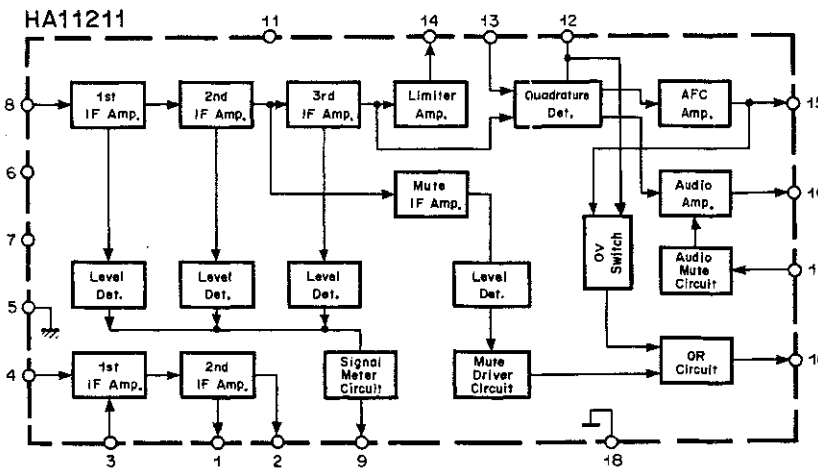

Fig. 10.4 FM Tuner System IC HA11211

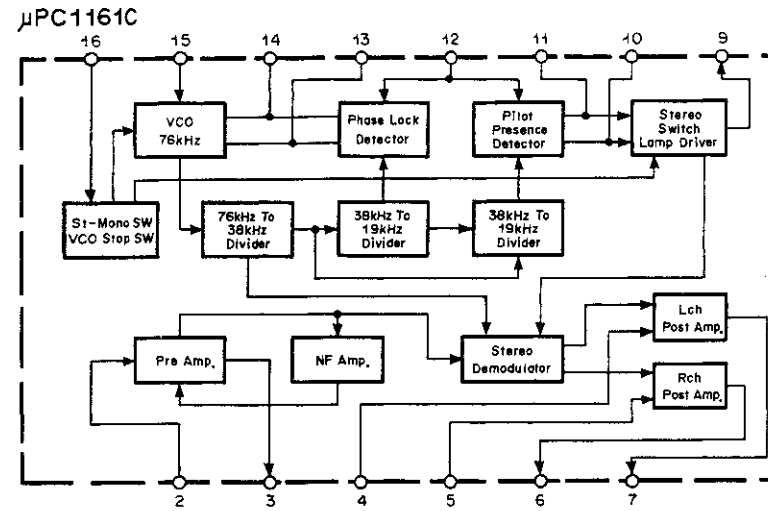

Fig. 10.5 FM Stereo Demodulator IC μPC1161C

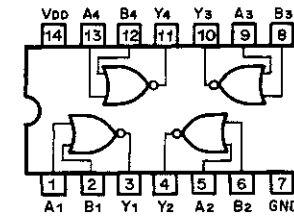

Fig. 10.7 NOR Gate C-MOS IC μPD4001C

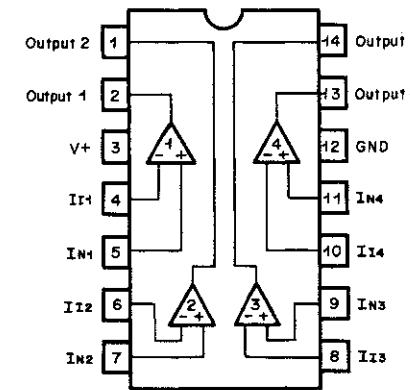

Fig. 10.9 Comparator IC μPC339C

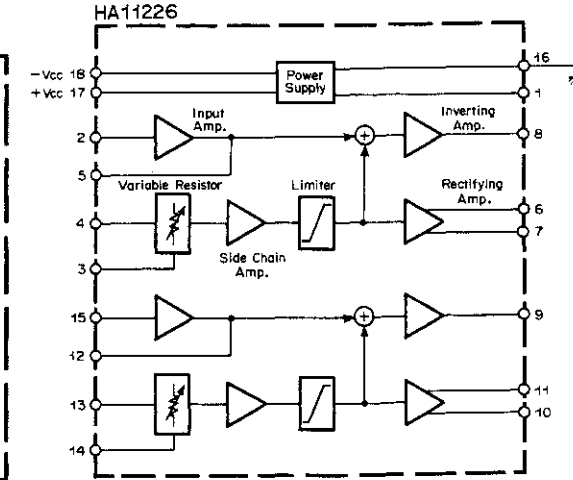

Fig. 10.6 Dolby NR IC HA11226

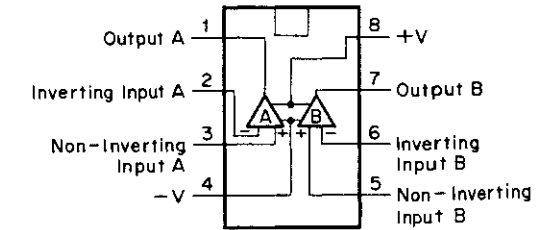

Fig. 10.8 OP Amp. IC RC4558 and RC4559

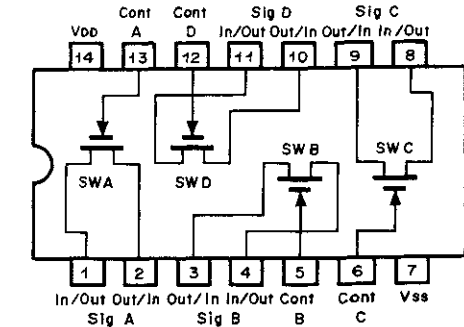

Fig. 10.10 Bilateral Switch C-MOS IC μPD4066C

11. WIRING DIAGRAM

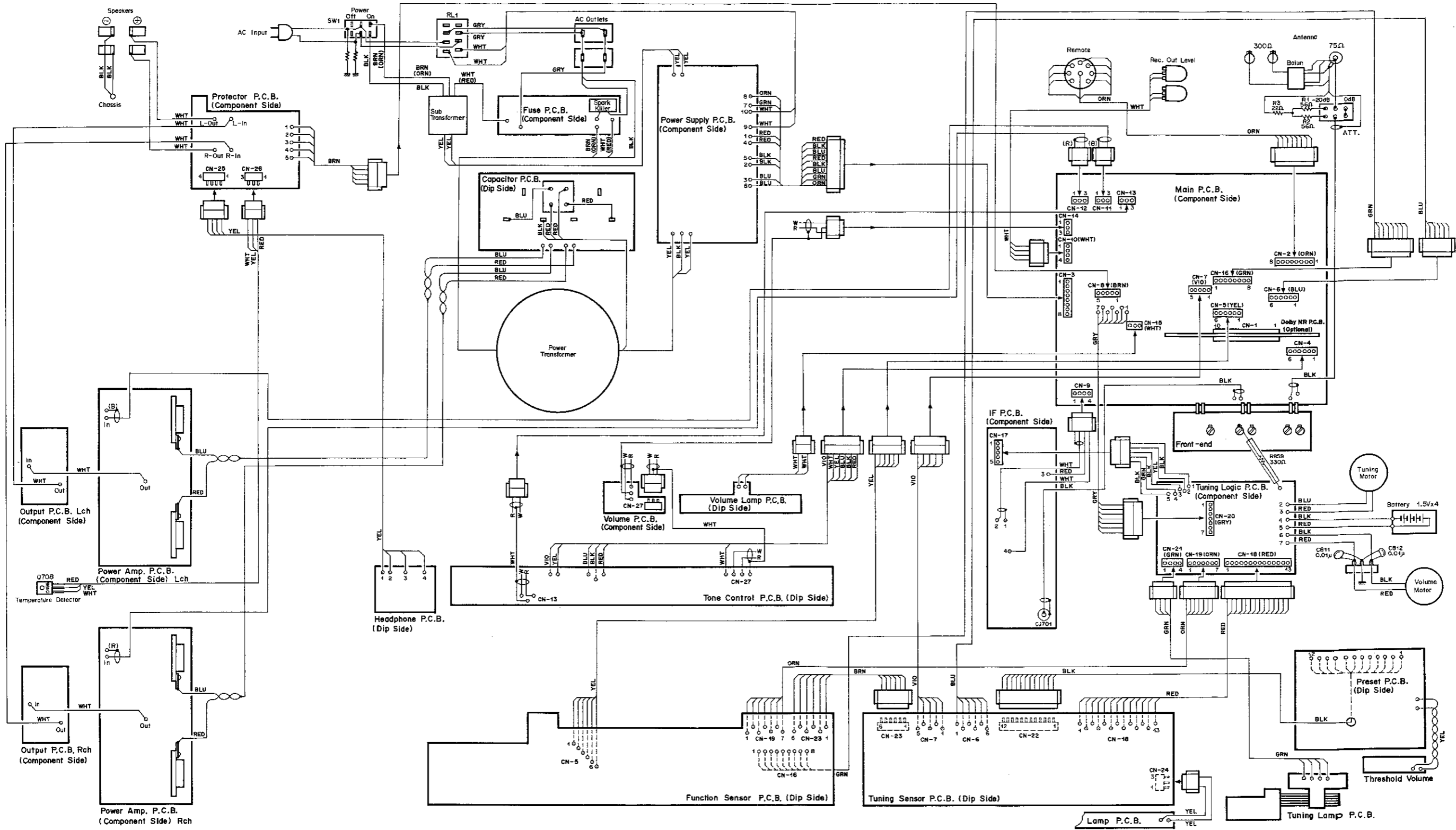

Fig. 11

Note: Table of wire colors

BLK - Black	GRY - Gray	BRN - Brown
BLU - Blue	GRN - Green	YEL - Yellow
ORN - Orange	RED - Red	WHT - White

12. REMOTE CONTROLLER RM-730 (OPTIONAL)

Note: Refer to item 2.6 "Principle of Operation for RM-730".

12.1. Schematic Diagrams

12.1.1. Transmitter

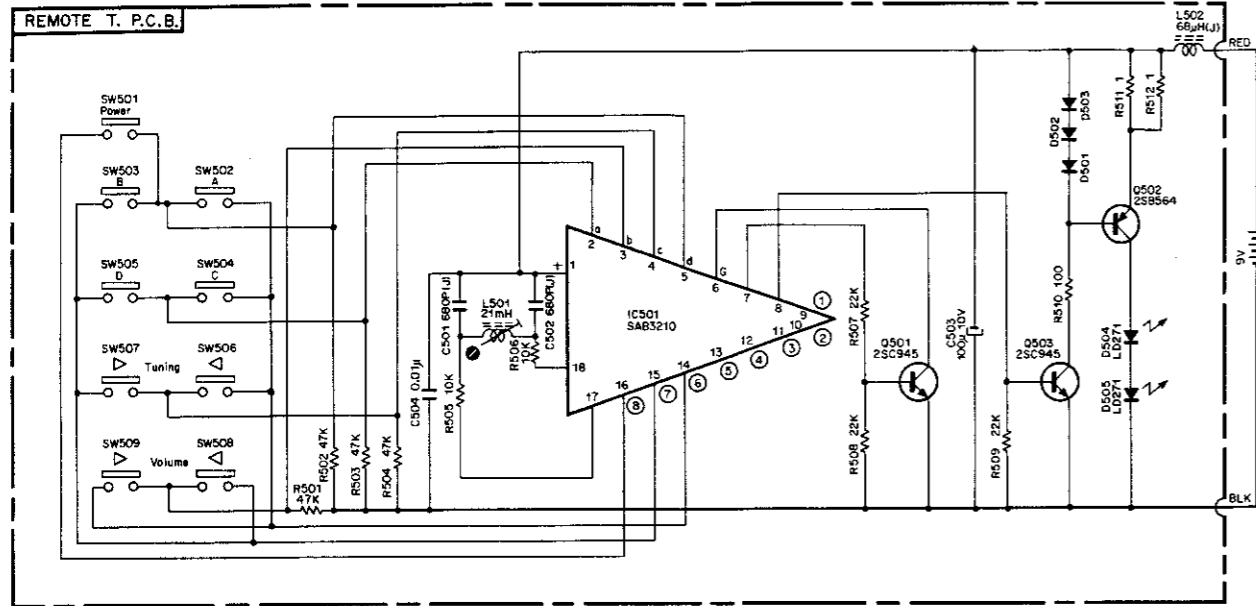

Fig. 12.1.1

12.1.2. Receiver

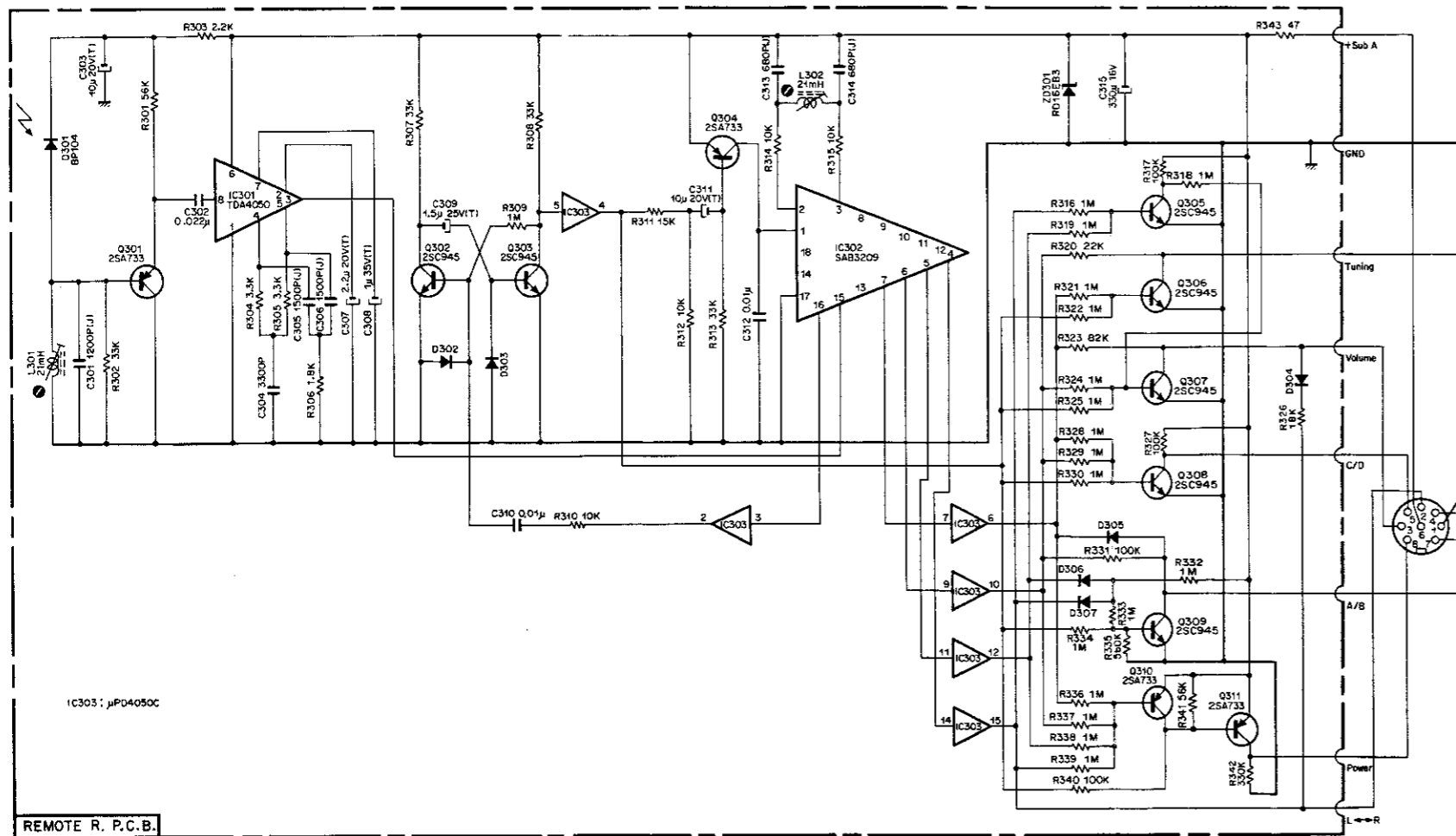

Fig. 12.1.2

12.2. Mounting Diagrams and Parts List

Note: Mounting diagram shows a dip side view of the printed circuit board.

12.2.1. Transmitter

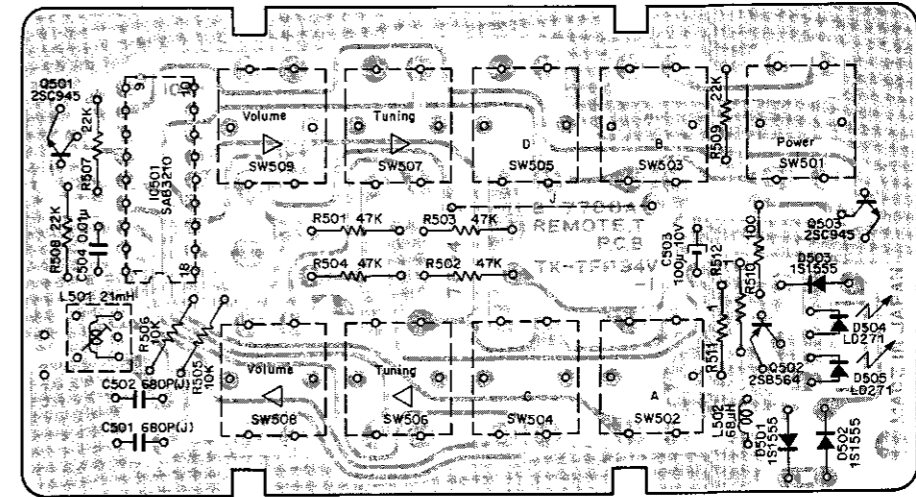

Fig. 12.2.1

Schematic Ref. No.	Part No.	Description
	BA03954A	Remote Transmitter P.C.B. Ass'y
IC501	0B07788A	Remote Transmitter P.C.B.
Q501,503	0B06161A	IC SAB3210
Q502	0B06100A	Transistor 2SC945A
D501-503	0B06069A	Transistor 2SB564
D504,505	0B01909A	Silicon Diode 1S1555 (3 pcs.)
L501	0B06164A	LED LD271
L502	0B06588A	Coil 21mH
	0B06561A	Inductor 68μH J
R501,502	0B05641A	Carbon Resistor 47K ERD-25T J
	503,504	
R505,506	0B01888A	Carbon Resistor 10K ERD-25T J
R507,508	0B05615A	Carbon Resistor 22K ERD-25T J
	509	
R510	0B01679A	Carbon Resistor 100 ERD-25T J
R511,512	0B05695A	Carbon Resistor 1 ERD-25T J
C501,502	0B09078A	S.P. Capacitor 680P 50V J
C503	0B05885A	Electrolytic Capacitor 100μ 10V
C504	0B09091A	Ceramic Capacitor 0.01μ 25V
SW501-509	0B07219A	Switch AKC8S (9 pcs.)
	0B05223A	Battery Snap B (1 pce.)

12.2.2. Receiver

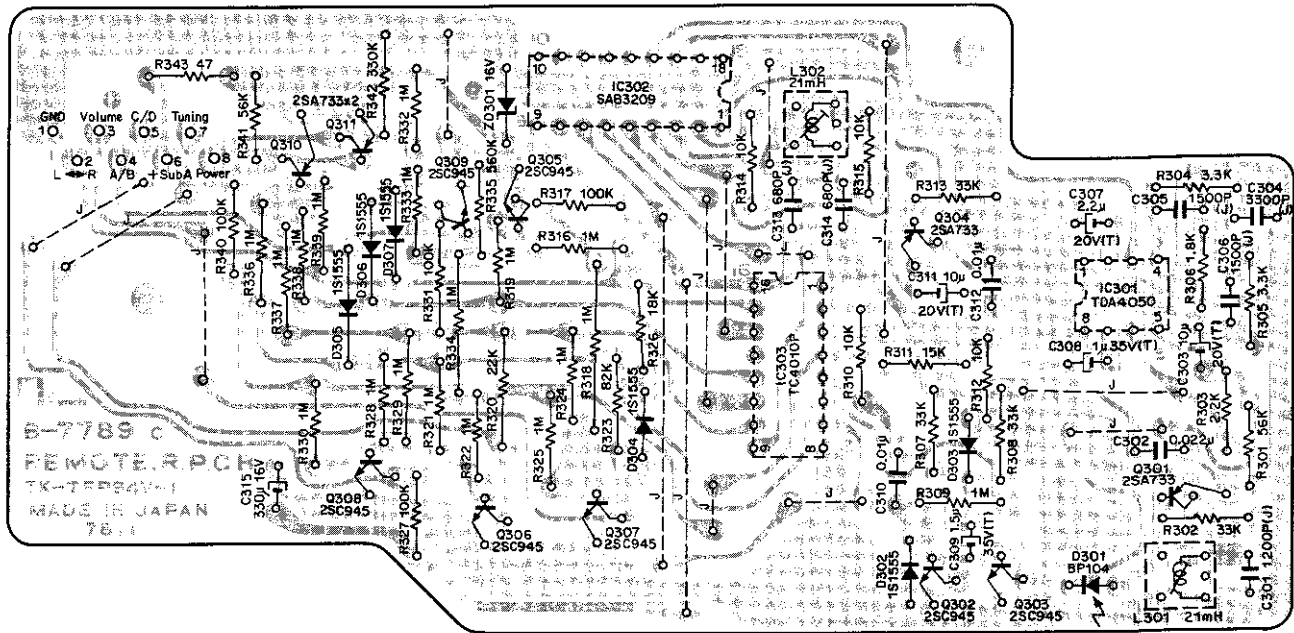

Fig. 12.2.2

Schematic Ref. No.	Part No.	Description	Schematic Ref. No.	Part No.	Description
	BA03955A	Remote Receiver P.C.B. Ass'y	R320	0B05615A	Carbon Resistor 22K ERD-25T J
	0B07789C	Remote Receiver P.C.B.	R323	0B05668A	Carbon Resistor 82K ERD-25T J
IC301	0B06163A	IC TDA4050	R326	0B05560A	Carbon Resistor 18K ERD-25T J
IC302	0B06162A	IC SAB3209	R335	0B05665A	Carbon Resistor 560K ERD-25T J
IC303	0B06166A	IC TC4010P	R342	0B05627A	Carbon Resistor 330K ERD-25T J
Q301,304 310,311	0B06013A	Transistor 2SA733	R343	0B01706A	Carbon Resistor 47 ERD-25T J
Q302,303 305-309	0B06100A	Transistor 2SC945A (7 pcs.)	C301	0B05790A	S.P. Capacitor 1200P 50V J
D301	0B06165A	Photo Diode BP104	C302	0B05953A	Ceramic Capacitor 0.022μ 25V
D302-307	0B01909A	Silicon Diode 1S1555 (6 pcs.)	C303,311	0B05581A	Tantalum Capacitor 10μ 20V
ZD301	0B06154A	Zener Diode 16V	C304	0B01914A	Mylar Capacitor 3300P 50V J
L301,302	0B06588A	Coil 21mH	C305,306	0B05653A	Mylar Capacitor 1500P 50V J
R301,341	0B05508A	Carbon Resistor 56K ERD-25T J	C307	0B05598A	Tantalum Capacitor 2.2μ 20V
R302,307 308,313	0B05509A	Carbon Resistor 33K ERD-25T J	C308	0B05638A	Tantalum Capacitor 1μ 35V
R303	0B05622A	Carbon Resistor 2.2K ERD-25T J	C309	0B05639A	Tantalum Capacitor 1.5μ 35V
R304,305	0B01681A	Carbon Resistor 3.3K ERD-25T J	C310,312	0B09091A	Ceramic Capacitor 0.01μ 25V
R306	0B05614A	Carbon Resistor 1.8K ERD-25T J	C313,314	0B09078A	S.P. Capacitor 680P 50V J
R309,316 318,319 321,322 324,325 328-330 332-334 336-339	0B05776A	Carbon Resistor 1M ERD-25T J (18 pcs.)	C315	0B01502A	Electrolytic Capacitor 330μ 16V
R310,312 314,315	0B01888A	Carbon Resistor 10K ERD-25T J		0B03924A	Gate Pin (2 pcs.)
R311	0B01683A	Carbon Resistor 15K ERD-25T J		0B08611A	Shield Cover (1 pce.)
R317,327 331,340	0B01889A	Carbon Resistor 100K ERD-25T J			

12.3. Adjustments

12.3.1. Transmitter

- (1) Disassemble the Bottom Cover, then remove the Remote Transmitter P.C.B. Ass'y.
- (2) Supply +9 V DC from an external Regulated Power Supply to the DC line of the Remote Transmitter P.C.B. Ass'y.
- (3) Connect a Frequency Counter across the IC501-18 pin and ground.
- (4) Push the Power Microswitch (SW501) to turn ON the power.
- (5) Adjust Coil L501 to obtain $62.5 \text{ kHz} \pm 50 \text{ Hz}$ on the Frequency Counter.
- (6) Turn OFF the power, then remove the Regulated Power Supply and the Frequency Counter.
- (7) Assemble the Remote Transmitter Ass'y.

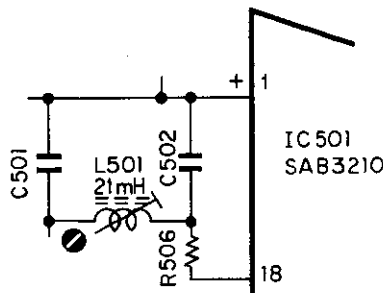

Fig. 12.3.1

12.3.2. Receiver

- (1) Disassemble the Receiver Case Ass'y, then remove the Remote Receiver P.C.B. Ass'y.
- (2) Supply +12 V DC to the Remote Receiver P.C.B. Ass'y from an external Regulated Power Supply by connecting +12 V DC of the Regulated Power Supply to pin No. 6 (RED) of the Remote Cord and ground to pin No. 1 (BLACK), or from the N-730 by plugging Remote Cord into Remote Control Socket of the N-730.
- (3) Connect a Frequency Counter across the IC302 (SAB3209)-2 pin and ground.
- (4) Adjust Coil L302 to obtain $62.5 \text{ kHz} \pm 50 \text{ Hz}$ on the Frequency Counter.

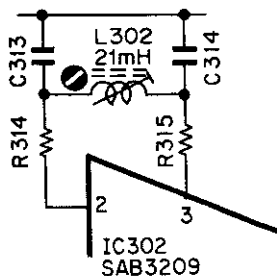

Fig. 12.3.2

- (5) Insert a $1\text{-M}\Omega$ resistor in series to the Oscillator output, then connect it across the base of Q301 and ground.
- (6) Set the output of the Oscillator to the order of a few voltage, then calibrate the oscillator frequency to $31.25 \text{ kHz} \pm 25 \text{ Hz}$ monitoring the frequency by the Frequency Counter.
Note: The waveform of the Oscillator output should be either square or sine.
- (7) Connect an AC Voltmeter across the emitter of Q301 and ground.
- (8) Adjust Coil L301 to obtain maximum reading on the AC Voltmeter.
- (9) Remove the Oscillator, AC Voltmeter and Regulated Power Supply, then assemble the Remote Receiver Ass'y.

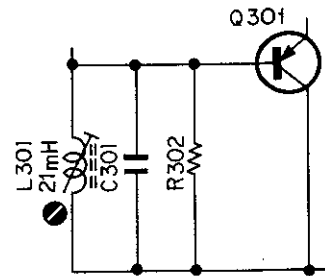

Fig. 12.3.3

12.3.3. Performance Check of Transmitter and Receiver

- (1) Connect the Receiver to the Remote Control Socket of the N-730.
- (2) Press each control switch of the Transmitter and check to insure whether every function operates accurately.

Note: Possible operating zone of the Transmitter is shown in Fig. 12.3.4.

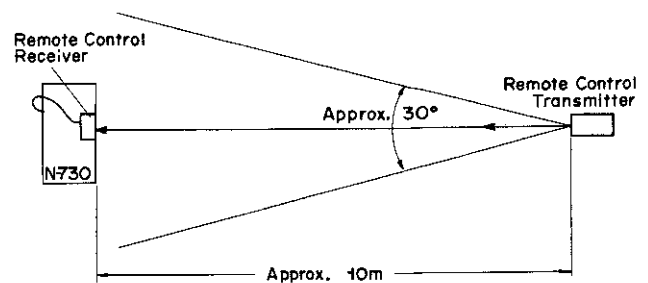

Fig. 12.3.4

12.4. Mechanism Ass'y and Parts List
 12.4.1. Transmitter

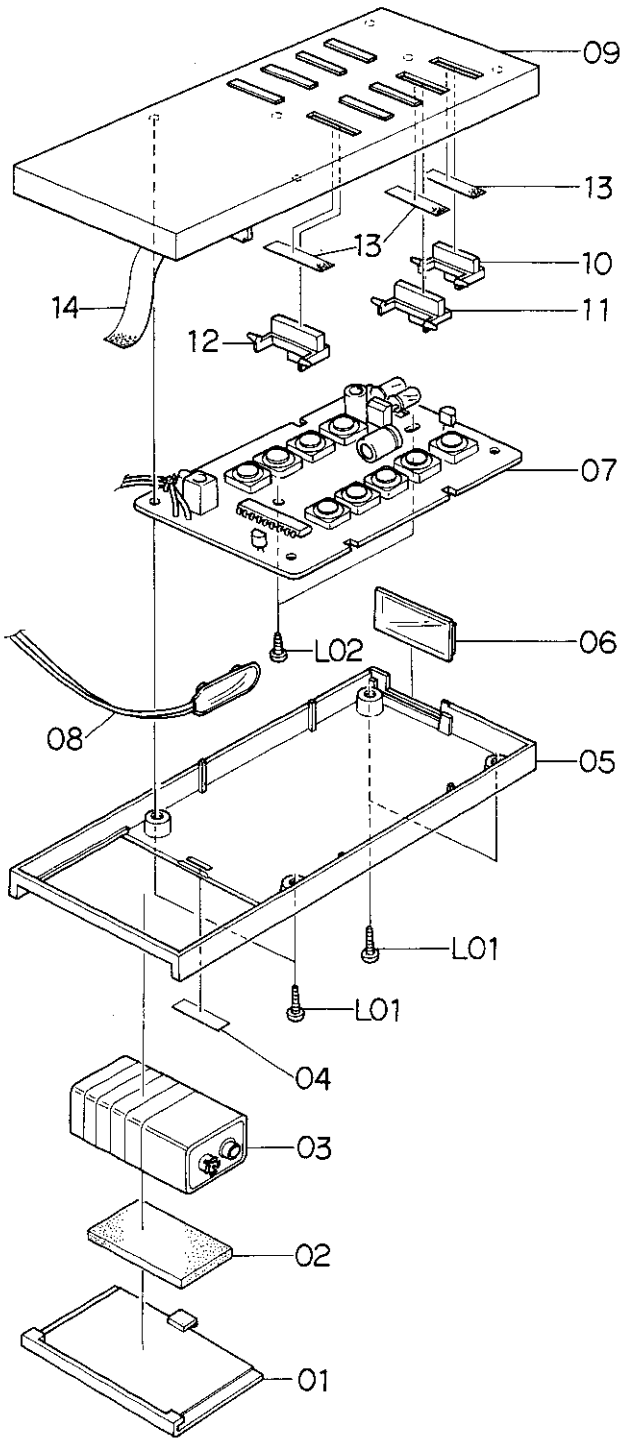

Fig. 12.4.1

Schematic Ref. No.	Part No.	Description	Q'ty
		Remote Transmitter Ass'y	
01	0H03661B	Battery Cover	1
02	0J03905A	Battery Cushion	1
03	0B08529A	Battery 9V	1
04	0M03950A	Serial No. Seal Transmitter	1
05	0H03656C	Under Case	1
06	0H03657A	Smoked Filter	1
07	BA03954A	Remote Transmitter P.C.B. Ass'y	1
08	0B05223A	Battery Snap B 110mm	1
09	HA03766A	Top Case Ass'y	1
10	0H03658A	Control Button A	1
11	0H03659A	Control Button B	6
12	0H03660A	Control Button C	2
13	0J03912A	Himelon	9
14	0J03906A	Battery Ribbon	1
L01	0E00825A	BT Screw M2.6x8 Philips	4
		Binding Head	
L02	0E00824A	BT Screw M2.6x6 Philips	2
		Pan Head	

12.4.2. Receiver

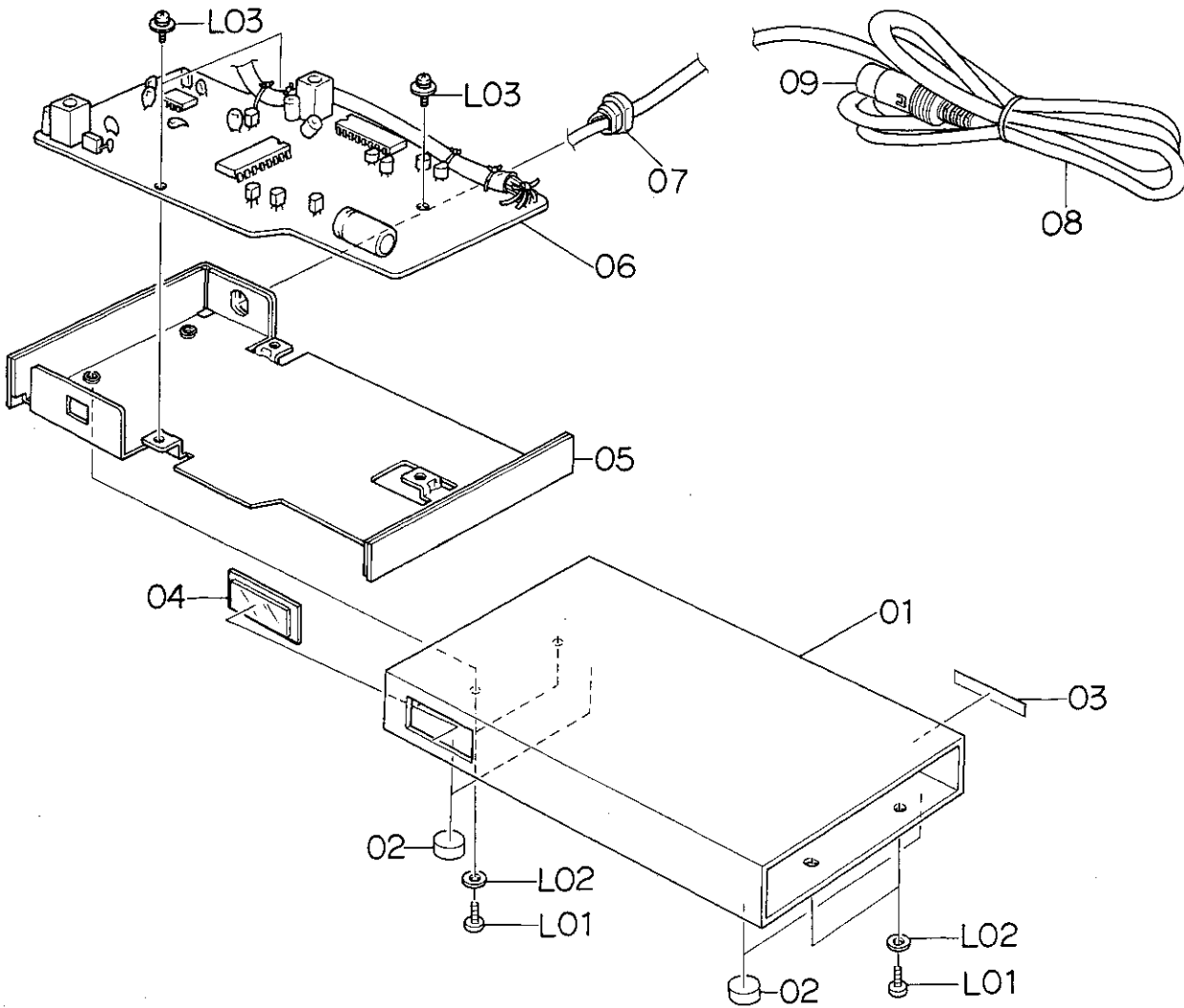

Fig. 12.4.2

Schematic Ref. No.	Part No.	Description	Q'ty
Remote Receiver Ass'y			
01	0H03652D	Outer Body	1
02	0H03653D	Leg RM730	4
03	0M03951A	Serial No. Seal Receiver	1
04	0H03649D	Acrylic Cover	1
05	JA03449A	Chassis Ass'y RM730	1
06	BA03955A	Remote Receiver P.C.B. Ass'y	1
07	0B08325U	Cord Bushing E	1
08	0B05222B	8P Cord 1.6M	1
09	0B08496A	8P DIN Plug	1
L01	0E00593A	Screw M3x6 Philips Binding Head (Bronze)	4
L02	0E00157A	Washer 3mm Plastics	4
L03	0E00606A	Screw M3x6 Philips Pan Head (3A)	3

13. SPECIFICATIONS

Amplifier

Power Output	105 Watts per channel, minimum continuous sine wave at 8 ohms, 5 — 20,000 Hz, with less than 0.02% THD 150 Watts per channel, minimum continuous sine wave at 4 ohms, 5 — 20,000 Hz, with less than 0.1% THD
IHF Power Bandwidth ...	10 — 20,000 Hz for less than 0.01% THD, both channels driven
Damping Factor	Greater than 100, 1 kHz, 8 ohms
Total Harmonic Distortion	Less than 0.004% up to 1 kHz Less than 0.008% up to 10 kHz Less than 0.02% up to 20 kHz
Intermodulation Distortion	Less than 0.004% at 8 ohms, 105 Watts output (60 Hz: 7 kHz, 4:1)
Frequency Response	
RIAA Deviation	Within ± 0.3 dB
Aux, Tape in Sp out, 8 ohms	10 — 30,000 Hz, +0.3, -1 dB
Main in to Sp out, 8 ohms	10 — 30,000 Hz, +0, -1 dB
Input Sensitivity/Impedance	
Phono	2 millivolts/100 kilohms
Aux, Tape	100 millivolts/10 kilohms
Main Amp.	1 volt/47 kilohms
Phono Overload	120 millivolts for 0.1% THD at 1 kHz
Signal-to-Noise Ratio	
Phono	Better than 83 dB, IHF-A, ref. to 2 millivolts (-137 dB equivalent input noise)
Aux, Tape	Better than 94 dB, IHF-A
Main Amp.	Better than 115 dB, IHF-A
Output Level/Impedance	
Rec Out	Variable, 100 — 300 millivolts/3.3 kilohms
Preamp Out	1 volt/1.2 kilohms
Residual Noise	Less than 0.3 millivolts, IHF-A, volume control at minimum
Tone Controls	
Bass	± 12 dB at 20 Hz
Treble	± 12 dB at 20 kHz
Contour Control (maximum)	-12 dB at 20 Hz -23 dB at 3 kHz -14 dB at 20 kHz
Channel Separation	
Phono in to Sp out ..	Better than 70 dB with 1 kilohm source impedance, volume control at -20 dB
Aux, Tape in to Sp out	Better than 70 dB with 1 kilohm source impedance, volume control at -20 dB
Headphone Output	60 milliwatts into 8 ohms

Tuner

Usable Sensitivity	2.2 microvolts at 300 ohms (12.0 dBf) for 30 dB quieting
50 dB Quieting Sensitivity	
Mono	4.5 microvolts at 300 ohms (18.3 dBf)
Stereo	45 microvolts at 300 ohms (38.3 dBf)
Signal-to-Noise Ratio	
Mono	Better than 75 dB at 65 dBf
Stereo	Better than 68 dB at 65 dBf
Muting Threshold	5.4 microvolts at 300 ohms (20 dBf)
Frequency Response	30 — 15,000 Hz +0.5, -1.5 dB
Distortion	
Mono	Less than 0.1% at 1 kHz, 100% modulation, 65 dBf
Stereo	Less than 0.15% at 1 kHz, 100% modulation, 65 dBf
Capture Ratio	1.5 dB
Channel Selectivity	Better than 70 dB
Stereo Separation	Better than 45 dB at 1 kHz Better than 30 dB at 10 kHz
Spurious Response	
Rejection	Better than 90 dB at 98 MHz
Image Rejection	Better than 85 dB at 98 MHz
IF Rejection	Better than 85 dB at 98 MHz
AM Suppression	Better than 55 dB
SCA Rejection	Better than 70 dB
Frequency Drift	Less than ± 50 kHz, -5° to +55° C, 1 kHz
MPX Filter	-70 dB at 19 kHz
Antenna Input	300 ohms balanced or 75 ohms unbalanced
Frequency Band	88 MHz — 108 MHz

General

Power Requirements	100, 120, 220 or 240 Volts AC, 50/60 Hz
Power Consumption	400 Watts
AC Outlets	2 switched, 100 Watts maximum
Dimensions	500(W) x 90(H) x 370(D) millimeters 19-11/16 x 3-1/2 x 14-1/2 inches
Weight	17.2 kilograms, 38 pounds

- Specifications and appearance design are subject to change for further improvement without notice.
- Dolby NR under license from Dolby Laboratories.
- The word "DOLBY NR" and the Double-D-Symbol are trademarks of Dolby Laboratories.