

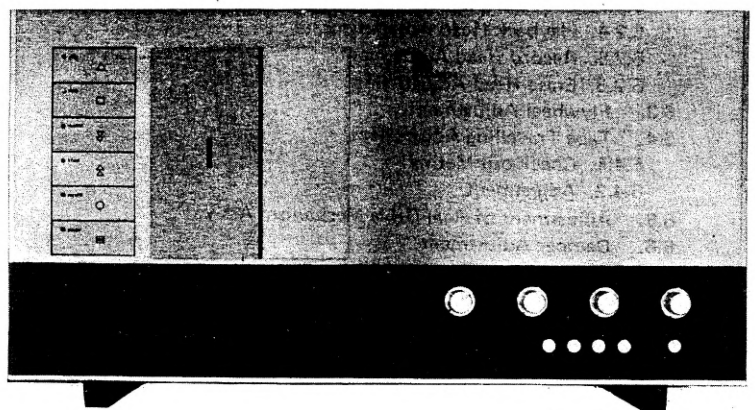

Service Manual

Nakamichi 700

3 Head Cassette System



Service Information



NAKAMICHI

Model Nakamichi 700
Serial No. from 3712701

Subject Modifications of Tape from Cr02 to SX,
Time Constant and Other Modifications
Accompanied.

No. OOD-M-0027
Date 5 March 1976

1. General:

- 1.1. Nakamichi Reference Cassette Tape has been changed from Cr02 to SX. The SX tape has the following features:
- a. Both sensitivity and maximum output level at high frequency are equal to those of Cr02 tape, and at middle and low frequency these will be increased approximately by 2 dB.
 - b. Shows less distortion than that of the conventional type Cr02 tape.
 - c. Head wear is similar to ferric oxide tapes.
- (Note: By the re-adjustment of the record bias current, compatibility of SX tape to Cr02 tape will not be lost and the products which have already been sold to customers could also use the SX tape for the Cr02.)

Details are explained in our Circular (No. 044, 20 February 1976).

- 1.2. Name plates of the tape position have been changed from "NORMAL" to "EX". And at EX position Nakamichi 700 will be tuned to the Nakamichi EXII Tape instead of the Nakamichi EX.
- 1.3. Since August 1975, the international standard of the playback equalization at low frequency against ferric oxide tapes has been changed to 3180 micro seconds from 1590 micro seconds. In accordance with the above change, we have changed the time constant of the EX position to $(3180\mu\text{s} + 120\mu\text{s})$ from $(1590\mu\text{s} + 120\mu\text{s})$.

And the time constant of the SX tape is $(3180\mu\text{s} + 70\mu\text{s})$.
Details are explained in our Circular (No. 043, 20 February 1976).

2. Tapes:

For SX Position:

Nakamichi SX Tape C-60 DA03156A
Nakamichi SX Tape C-90 DA03157A
TDK SA Tape C-60 and C-90
Reference SX Tape (for alignment) DA09025A

For EX Position:

Nakamichi EXII Tape C-60 DAO3153A
Nakamichi EXII Tape C-90 DAO3154A
Reference EXII Tape (for alignment) DAO9021A
Nakamichi EX Tape and Others

3. Adjustment for the SX tape:

Same as Cr02 tape.

4. Modifications:

Printed circuit board (P.C.B.) assembly and name plates have been modified.

4.1. Main P.C.B. Ass'y

Part No. BA-3759 (previous part No. BA-3700)

a. Modifications for SX tape (Record Cal. Circuit):

R153,253: 6.8K to 8.2K
R156,256: 8.2K to 10K
C151,251: 5600P to 6800P
C153,253: 1500P to 1000P
R176,276: 47 ohm has been added to suppress the record peaking level.

b. Modifications for 3180us low frequency time constant (Record Cal. Circuit):

R157,257: 1.5K to 1.8K
C154,254: 1u to 1.5u
Connector CN3 terminal No.7 and 9 have been cut.

c. Name Plate:

Level control panel has been changed from part No. M-3355 to M-3665.

4.2. Name Plate:

Service Manual Page	Schematic Ref. No.	Part No.	Descriptions	Q'ty
63	15	HA-3638 (Previous part No. HA-3627)	Control Panel Ass'y	1

5. P.C.B. Assembly:

Main P.C.B. Ass'y BA-3759
(For SX tape, refer to the parts list). See Fig. 1.
P.B. Dolby P.C.B. Ass'y BA-3588
Record Dolby P.C.B. Ass'y BA-3589

Service Information



NAKAMICHI

Model _____
Serial No. from _____

Subject _____

No. 00D-M-0023 (3/5)
Date _____

2.5. Playback Head Azimuth Alignment:

- (1) Load the 15KHz Azimuth Tape (DA09004A) for adjusting the P.B. head azimuth. Set the Monitor SW. to the Tape position and playback. Adjust the P.B. head azimuth alignment screw C until each level meter of both channels reads the maximum value.
- (2) After completion of the adjustment in this step, check the item 2.4 Playback Head Track Alignment then recheck Playback Head Azimuth.

2.6. Record Head Height Alignment:

- (1) Load the Reference CrO2 Tape (DA09009A), set the Test Tone SW. to On position, the Tape Selector SW. to the Tape position. Set to record mode and adjust record head azimuth alignment screw D until the alignment beacon started flickering alternately.
- (2) Aligning Step (1) as above, align the screw F to obtain maximum reading of both channels.
- (3) Check to insure the following.
 - a. Record the same portion of the both A and B sides of the tape after record head azimuth is aligned.
 - b. Immerse the recorded tape into a magnetized developing solution. In turn, check to insure that the recording head tracks across the center are separated by space of 0.4 to 0.6mm typically 0.5mm as illustrated in the Fig.2.

Note: Liquid for tape magnetized development:

MAGNA-SEE, SOUND CRAFT a product of CBS RECORDS.

After development, clean the tape otherwise pressure roller will become dirty.

Amplifier Schematic Diagram

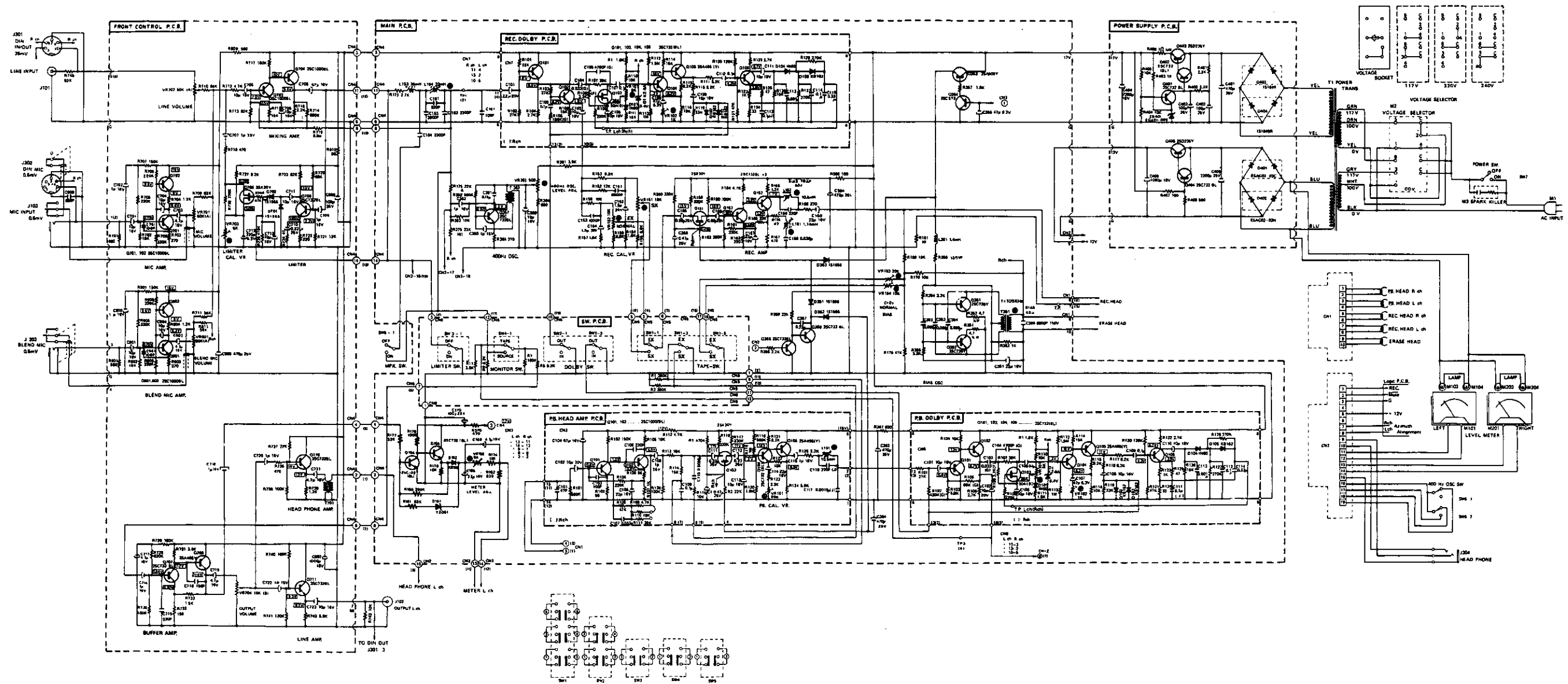

Fig. 2 Serial No. 3712701-

Service Information



NAKAMICHI

Model _____
Serial No. from _____

Subject _____

No. OOD-M-0023 (4/5)
Date _____

2.7. Head Height Check by Tack Viewer:

- (1) Load the Track Viewer again and check to insure whether the deviation from the L-R center is within 0.2mm.
- (2) If the deviation is more than 0.2mm, tape travelling will be defective such as defective head contact, pressure roller, capstan, etc.

Check to insure "2.3 Tape Travelling Check".

2.8. Apply a drip of lock tight paint to the A, B, E and F.

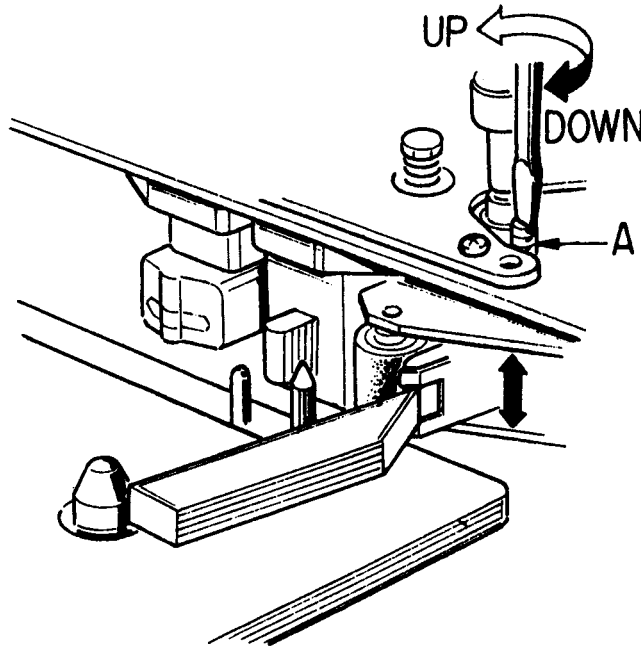

Fig.1

Service Information



NAKAMICHI

Model Nakamichi 700 and 1000
Serial No. from 3709323 (700), 3107001 (1000)
Subject Adjustment Procedures for
New Type Head Base Block

No. OOD-M-0023 (1/5)
Date 19 December 1975

1. General:

The adjustment procedures for new head block cover the machines bearing serial Nos. 3709323 and after for Nakamichi 700 and 3107001 and after for Nakamichi 1000.

Though we have already informed the adjustment procedures for new type head base block in the Nakamichi 700 service manual and service information OOD-M-0015 (1/9-9/9) for Nakamichi 1000, this explanation is revised information and it is more recommendable that you adjust new type head block according to this information.

New type head base block is head height adjustable, but the previous type required additional head spacer for head height adjustment.

Nakamichi 700---Head Mount Base (E) Ass'y CA-5168

Nakamichi 1000--Head Mount Base (D) Ass'y CA-5167

2. Adjustment Procedure:

2.1. Tape Guide Height Adjustment:

Load with care the Tape Guide Height Measurement Jig (Information Terminals, Sunnyvale California --Model Number M300).

Refer to the Fig.1, and adjust the tape guide height adjusting screw A so that the tape guide is fixed to the jig.

One turning for one time (one rotation) becomes 0.45mm tape guide height movement.

2.2. Head Height Adjustment by Track Viewer:

(1) Load the Track Viewer (DA09012A), and check the positions of playback and record heads. While adjustment, check to insure that the L-R center of each head coincides in position with the middle point between two lines (0.3mm distance) on the Track Viewer.

(2) If the L-R center deviates from the middle point, correct the head height deviation by adjusting screws E and F, together with adjusting C and D for correcting head azimuth.

Service Information



NAKAMICHI

Model _____
Serial No. from _____

Subject _____

No. OOD-M-0023 (2/5)

Date _____

2.3. Tape Travelling Check:

Load the Tape Travelling Cassette (DA09011A), and set the playback mode. Check to insure that the tape height while running is within $\pm 0.3\text{mm}$ at any tape position when measured from the center of a cassette housing.

Note: Observing tape travelling on the playback head, check the following points:

- (1) Tape travelling does not wave.
- (2) At a tape starting point, the tolerance of tape travelling fluctuation is within about $\pm 0.3\text{mm}$.

If not, adjust the pressure roller height by adjusting screw B located at the take-up reel side. After the tape travel is corrected, check to insure that the pressure roller position is within $\pm 1\text{mm}$ when measured from the center of a cassette housing. Note that in most cases of playback head adjustment turning of the screw B will not be required for misalignment.

If tape travel cannot still be adjusted, refer to the "Tape Travelling Adjustment" on the Service Manuals.

2.4. Playback Head Track Alignment (Playback Head Height Alignment):

Load the Track Alignment Tape (DA09007A) and check the head height on the cassette tape deck. Set the Monitor SW. to Tape and play the tape back.

Adjust the playback head height screw E until each level meter of both channels reads the minimum value.

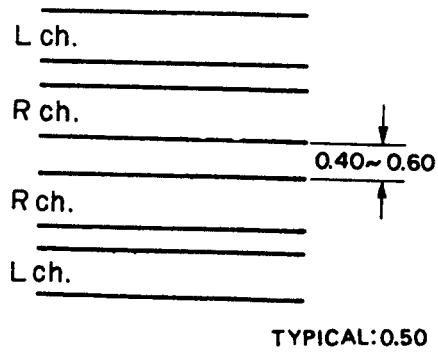

Fig. 2

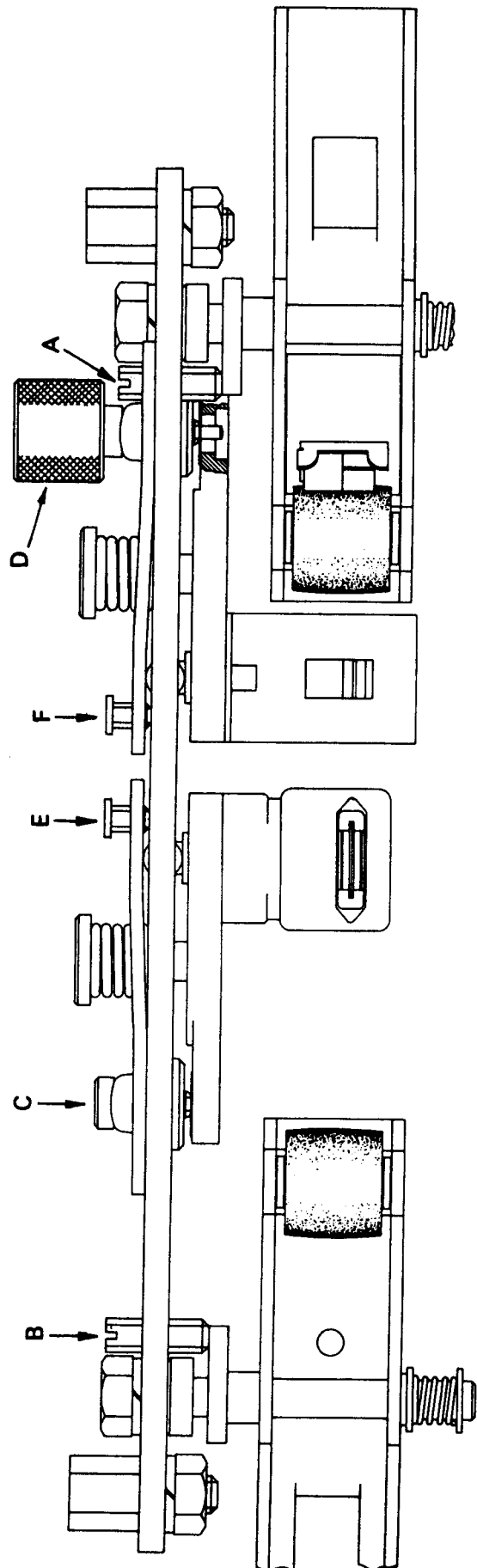

Fig. 3 New Head Base Block Assembly

10.26. Cassette Spring Assembly R (C03)	74
10.27. Base Switch Assembly (C04)	74
10.28. Rec. Head Assembly (C05) (Previous Type)	74
10.29. P.B. Head Assembly (C06) (Previous Type)	74
10.30. Head Mount Base Block (D01) (New Type)	75
10.31. Head Mount Base (E) Ass'y (E01) (New Type)	75
10.32. Mount Base Cover (B) Ass'y (E02) (New Type)	75
10.33. Playback Head Ass'y (F01) (New Type)	75
10.34. Record Head Ass'y (F02) (New Type)	75
11. Mounting Diagram / Parts List	76
11.1. Main P.C.B.	76
11.2. P.B. Dolby P.C.B.	78
11.3. Rec. Dolby P.C.B.	79
11.4. P.B. Head Amp. P.C.B.	80
11.5. Switch P.C.B.	81
11.6. Front Control P.C.B.	82
11.7. Logic Control P.C.B.	84
11.8. Motor Governor P.C.B.	86
11.9. 400Hz Osc. Sw. P.C.B.	86
11.10. Shut-off Sensor P.C.B. and Shut-off Luminous P.C.B.	86
11.11. Head Base Sw. P.C.B.	86
11.12. Power Supply P.C.B.	87
12. Wiring Diagram	88
12.1. Amplifier	88
12.2. Logic Control	89
13. Level Diagram	90
14. EQ. Amp. Frequency Response	90
15. Block Diagram	91
16. Schematic Diagram	91
16.1. Motor Governor	91
16.2. Amplifier	92
16.3. Logic Control	93
17. Specifications	95

1. GENERAL

Nakamichi 700 control functions are shown with the reference to the following explanations.

For keeping the optimum performance of the Nakamichi 700, maintenance such as cleaning of head, capstan shaft and pressure roller, and demagnetization of heads, lubrication, etc. are required.

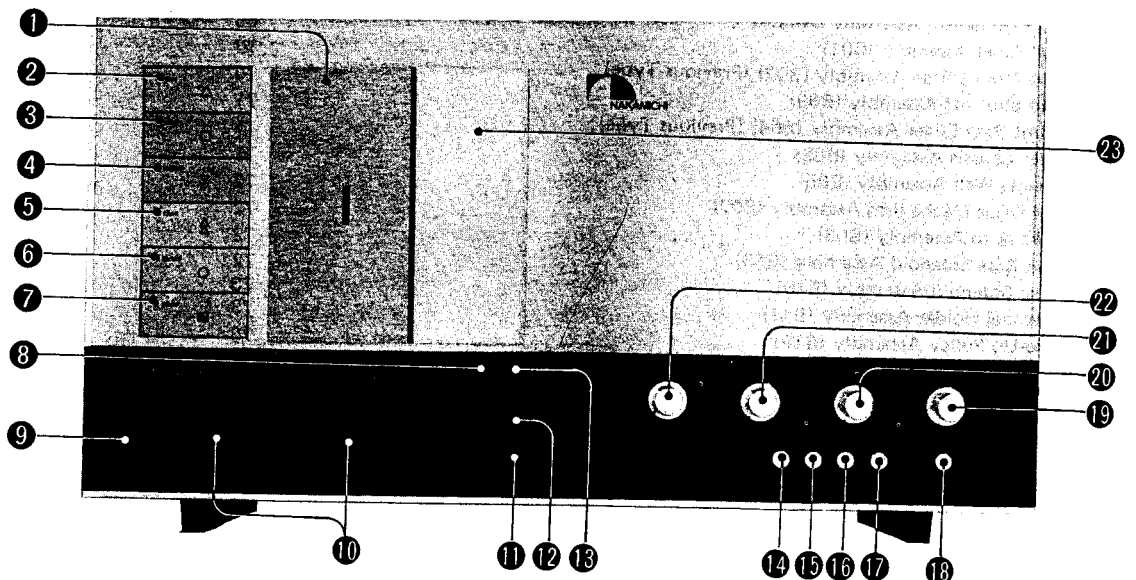

Fig. 1.1. (Front View)

CONTENTS

1. General	4
2. Principle of Operation	6
2.1. Mechanisms	6
2.1.1. 3 Head Configuration	6
2.1.2. Double Capstan Tape Drive	7
2.1.3. Reel Drive Mechanism	8
2.2. Amp. Circuits	10
2.2.1. Record Dolby Circuit	10
2.2.2. P.B. Dolby Circuit	12
2.2.3. P.B. Head Amp.	15
2.2.4. MIC Amp. Board	16
2.2.5. Mixing Amp. & Limiter	18
2.2.6. Rec. EQ. Amp.	20
2.2.7. Bias Osc. & 400Hz Osc.	22
2.2.8. Line Amp. & Meter Amp.	23
2.2.9. Power Supply	24
2.3. Mechanism Control Circuits	25
2.3.1. Logic Control	25
2.3.2. Shut-off Sensor & Detector	32
2.3.3. Azimuth Alignment Detector	34
2.3.4. Motor Governor	37
3. Dismantling	41
3.1. Front Panel Ass'y	
3.2. Head Mount Base Ass'y (Previous Type) and Pressure Roller Arm Ass'y	
3.3. Head Mount Base (E) Ass'y (New Type) and Pressure Roller Arm Ass'y	
3.4. Head Base Damper Ass'y and Eject Damper Bracket Ass'y	
3.5. Reel Drive Mechanism Ass'y	
3.6. Flywheel Ass'y	
3.7. Control Button Ass'y	
3.8. Sub-Motor Ass'y	
3.9. Main Motor Ass'y	
3.10. Transformer	
3.11. Main Board Ass'y	
3.12. Power Supply Ass'y	
3.13. P.B. Head Amp. Ass'y, P.B. Dolby NR Ass'y and Rec. Dolby NR Ass'y	
3.14. Front Control Ass'y and Switch Board Ass'y	
3.15. 400Hz Osc. Sw. P.C.B. Ass'y	
3.16. Shut-off Luminous P.C.B. Ass'y and Shut-off Sensor P.C.B. Ass'y	
4. Check-out Procedures	42
4.1. Check-out Procedures for Inspection	42
4.2. Check Methods	42
5. Measurement and Maintenance Instruments	43
5.1. Measurement Instruments and Connection	43
5.2. Maintenance Instruments	45
6. Mechanical Measurements and Adjustments	46
6.1. Take-up, Fast Forward and Rewind Torque Adjustment	46
6.1.1. Take-up Torque Adjustment	46
6.1.2. Fast Forward and Rewind Torque Adjustment	46
6.2. Headblock	46
6.2.1. Head Replacement Procedures	46
6.2.2. Head Height Adjustment (Previous Type)	46
6.2.3. Head Height Adjustment (New Type)	47
6.2.4. Playback Head Adjustment	47
6.2.5. Record Head Adjustment	48
6.2.6. Erase Head Adjustment	48
6.3. Flywheel Adjustment	48
6.4. Tape Travelling Adjustment	48
6.4.1. Check-out Method	48
6.4.2. Adjustment	48
6.5. Adjustment of Reel Drive Mechanism Ass'y	49
6.6. Damper Adjustment	49
6.6.1. Head Base Damper	49
6.6.2. Eject Damper	49
6.7. Lubrication	49

7. Electrical Measurements and Adjustments	50
7.1. Tape Speed	50
7.2. Meter Level Calibration	50
7.3. 400Hz Test Tone	50
7.4. 19KHz MPX Filter	50
7.5. Limiter Level	51
7.6. Playback Level Calibration	51
7.7. Playback Frequency Response	51
7.8. Head Azimuth Alignment (Playback Head)	51
7.9. Bias Oscillator Frequency	51
7.10. Bias Trap (Bias Leakage)	52
7.10.1. Record Amp. Bias Trap	52
7.10.2. Playback Amp. Bias Trap	52
7.11. Recording Equalization Peaking	52
7.12. Alignment Beacon Phase Adjustment	52
7.13. Record Bias and Record/Playback Level	53
7.14. Record Dolby Board Adjustment Procedure	54
7.15. Playback Dolby Board Adjustment Procedure	54
7.16. Signal to Noise Ratio Measurement	54
7.17. Channel Separation Measurement	54
7.17.1. L Channel to Right Channel	54
7.17.2. Right Channel to L Channel	54
7.18. Crosstalk Measurement	54
7.19. Erasure Measurement	55
7.20. Total Harmonic Distortion Measurement	55
7.21. Wow/Flutter Measurement	55
7.22. Adjustment and Measurement of Frequency Response	55
7.22.1. Adjustment of Playback Frequency Response	55
7.22.2. Adjustment of Overall Frequency Response	56
7.23. Adjustments Table	57
8. Parts Location for Electrical Adjustment	57
9. Trouble Shooting	58
9.1. Note	58
9.2. Trouble Shoots	58
9.3. Check Methods When Parts are Replaced	61
9.4. Table for Common Use of Semi-Conductors	62
10. Mechanism Assembly /Parts List	63
10.1. Synthesis Assembly (A01)	63
10.2. Chassis Assembly (A02)	64
10.3. Cabinet Assembly (A03)	65
10.4. Mechanism Assembly	66
10.4.1. Mechanism Assembly (A04.1)	66
10.4.2. Mechanism Assembly (A04.2)	67
10.4.3. Mechanism Assembly (A04.3)	68
10.4.4. Mechanism Assembly (A04.4)	69
10.5. Rear Panel Assembly (B01)	70
10.6. Head Mount Base Assembly (B02) (Previous Type)	70
10.7. Auto Shut-off Assembly (B03)	71
10.8. Mount Base Cover Assembly (B04) (Previous Type)	71
10.9. Meter Chassis Assembly (B05)	71
10.10. Cassette Well Assembly (B06)	72
10.11. Reel Drive Mechanism Assembly (B07)	72
10.12. Brake Arm Assembly (B08)	72
10.13. Head Base Solenoid Assembly (B09)	72
10.14. Brake Solenoid Assembly (B10)	73
10.15. Flywheel Holder Assembly (B11)	73
10.16. Take-Up Pulley Assembly (B12)	73
10.17. Motor Cap Assembly (B13)	73
10.18. Base Switch Assembly (B14)	73
10.19. Sub Motor Assembly (B15)	73
10.20. Main Motor Assembly (B16)	74
10.21. Eject Damper Bracket Assembly (B17)	74
10.22. Cassette Holder Assembly (B18)	74
10.23. Memory Switch Assembly (B19)	74
10.24. Pressure Roller Arm (C) Assembly (S) 700 (C01)	74
10.25. Cassette Spring Assembly L (C02)	74

P.B. Haed Amp. P.C.B. Ass'y	BA-3651
Switch Board Ass'y	BA-3609
Front Control Ass'y	BA-3701
Logic Control P.C.B. Ass'y	BA-3689
Motor Governor P.C.B. Ass'y	BA-3662
400Hz Osc. SW. P.C.B. Ass'y 700 .	BA-3678
Shut-off Sensor P.C.B. Ass'y	BA-3664
Shut-off Luminous P.C.B. Ass'y ..	BA-3663
Head Base Switch P.C.B. Ass'y ...	BA-3666
Power Supply Ass'y	BA-3608

6. Amplifier Schematic Diagram:

See Fig. 2.

Schematic Ref. No.	Part No.	Description	Schematic Ref. No.	Part No.	Description
BA 3759 Main P.C.B. Ass'y			- 400Hz Osc. -		
- Rec. Amp. -			Q357	B-6005	Transistor 2SC732 (BL)
Q151,251	B-1600	FET 2SK30 (Y)	T352	B-3879	Trans.
Q152,252	B-6005	Transistor 2SC732 (BL)	VR351	B-1596	Semi-fixed Volume 500
153,253			R361	B-5664	Carbon Resistor 3.9K ELR% J
355,356			R362	B-5665	Carbon Resistor 560K ELR% J
D351,352	B-1909	Silicon Diode 1S1555	R363	B-1888	Carbon Resistor 10K R% J
353			R364	B-5559	Carbon Resistor 680 ELR% J
L151,251	B-3858	Peaking Coil 1.14mH	R365	B-5645	Carbon Resistor 270 R% J
L152,252	B-3859	Bias Trap Coil 10.5mH	C360,362	B-1405	Electrolytic Capacitor 1μ 16V
VR151,251	B-1595	Semi-fixed Volume 10K	C361	B-5551	Mylar Capacitor 0.15μ 50V K
152,252			C359	B-1412	Electrolytic Capacitor 10μ 16V
R152,252	B-5650	Carbon Resistor 12K ELR% J	- Meter -		
R153,253	B-1878	Carbon Resistor 8.2K ELR% J	Q154,254	B-6005	Transistor 2SC732 (BL)
R154,254	B-1830	Carbon Resistor 1.8K ELR% J	155,255		
157,257			D151,251	B-6058	Zener Diode YZ-051
R155,255	B-1877	Carbon Resistor 6.8K ELR% J	D152,252	B-6007	Silicon Diode KB165
158,258			VR155,255	B-1805	Semi-fixed Volume 5K
R156,256	B-1833	Carbon Resistor 10K ELR% J	R174,274	B-5591	Carbon Resistor 15K ELR% J
R159,259	B-1921	Carbon Resistor 330K ELR% J	R177,277	B-5648	Carbon Resistor 22K RD% G
160,260			R178,278	B-1920	Carbon Resistor 100K ELR% J
360			R179,279	B-1833	Carbon Resistor 10K ELR% J
R161,261	B-5596	Carbon Resistor 220K ELR% J	R180,280	B-5544	Carbon Resistor 390K RD% G
R162,262	B-5595	Carbon Resistor 390K ELR% J	R181,281	B-5766	Carbon Resistor 82K RD% G
R163,263	B-5608	Carbon Resistor 220 ELR% J	R812,282	B-5511	Carbon Resistor 820 ELR% J
R164,264	B-1795	Carbon Resistor 4.7K ELR% J	R369	B-5576	Carbon Resistor 470 R% J
R165,265	B-1879	Carbon Resistor 33K ELR% J	C165,265	B-5636	Tantalum Capacitor 22μ 16V
R166,266	B-5565	Carbon Resistor 1.2K ELR% J	C166,266	B-5657	Tantalum Capacitor 4.7μ 16V
R167,267	B-1792	Carbon Resistor 470 ELR% J	C365	B-1272	Electrolytic Capacitor 100μ 25V
R168,268	B-5651	Carbon Resistor 270 ELR% J	- Miscellaneous -		
R358	B-5566	Carbon Resistor 2.2K ELR% J	L153,253	B-3919	Inductor 36mH
R359	B-5661	Carbon Resistor 22K ELR% J	L154,254	B-3857	19KHz Coil
R368	B-5558	Carbon Resistor 100 ELR% J	R173,273	B-5629	Carbon Resistor 2.7K R% J
C151,251	B-5530	Mylar Capacitor 6800P 50V J	R175,275	B-5648	Carbon Resistor 22K RD% G
C152,252	B-5639	Tantalum Capacitor 1.5μ 35V M	R367	B-1680	Carbon Resistor 820 R% J
154,254			C161,261	B-5666	Mylar Capacitor 820P 50V K
C153,253	B-5550	Mylar Capacitor 1000P 50V J	C162,262	B-1802	Mylar Capacitor 2200P 50V J
C155,255	B-1320	Aluminium Capacitor 0.68μ 25V	164,264		
156,256			C163,263	B-1804	Mylar Capacitor 3900P 50V J
C157,257	B-5636	Tantalum Capacitor 22μ 16V	C167,267	B-1288	Ceramic Capacitor 100P 50V M
C158,258	B-5660	Mylar Capacitor 0.039μ 50V J	C363,364	B-1401	Electrolytic Capacitor 470μ 25V
C159,259	B-1289	Ceramic Capacitor 220P 50V M	BA-3562	19P Connector Sub Ass'y	
C160,C260	B-1862	Electrolytic Capacitor 22μ 16V	BA-3703	10P Connector Ass'y	
C357	B-5584	Mylar Capacitor 0.22μ 50V M	BA-3702	14P Connector Ass'y	
C358	B-1376	Aluminum Capacitor 0.47μ 25V	J-3186	Level Control Stud	
C364	B-1401	Electrolytic Capacitor 470μ 25V	J-3368	Calibration Knob	
R176,276	B-5569	Carbon Resistor 47 ELR% J	M-3665	Level Control Panel	
- Bias Osc. -			B-7604	Main P.C.B.	
Q351,352	B-1338	Transistor 2SC735 (Y)	B-3924	Gate Pin	
Q353	B-6024	Transistor 2SA509 (Y)	B-8001	Tub	
Q354	B-1367	Transistor 2SC373	E-157	Washer 3 Colalr	
L351	B-3861	Inductor 1.4mH	E-254	Washer 3.1 Mylar	
T351	B-6515	Osc. Coil	E-507	Nut Hex M3	
VR153,253	B-1923	Semi-fixed Volume 20K	E-599	Screw M3x10 Phillips Pan Head	
VR154,254	B-1595	Semi-fixed Volume 10K			
R151,251	B-5663	Carbon Resistor 10 ELR% J			
R169,269	B-1833	Carbon Resistor 10K ELR% J			
170,270					
R176,276	B-5562	Carbon Resistor 47K ELR% J			
R351,352	B-5662	Carbon Resistor 4.7 R% J			
R353	B-1781	Carbon Resistor 1K ELR% J			
R354,355	B-1793	Carbon Resistor 3.3K ELR% J			
R356	B-5761	Cement Resistor 12 5W			
R357	B-1830	Carbon Resistor 1.8K ELR% J			
C351	B-1862	Electrolytic Capacitor 22μ 16V			
C352,C353	B-5586	Mylar Capacitor 0.068μ 50V K			
354					
C355	B-5634	S.P. Capacitor 6800P 150V J			
C356	B-1404	Electrolytic Capacitor 47μ 6.3V			

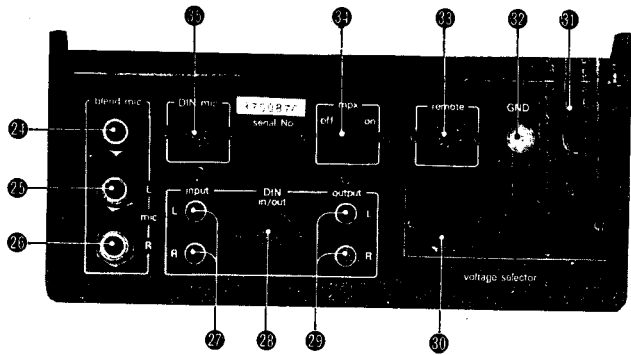

Fig. 1.2. (Top View)

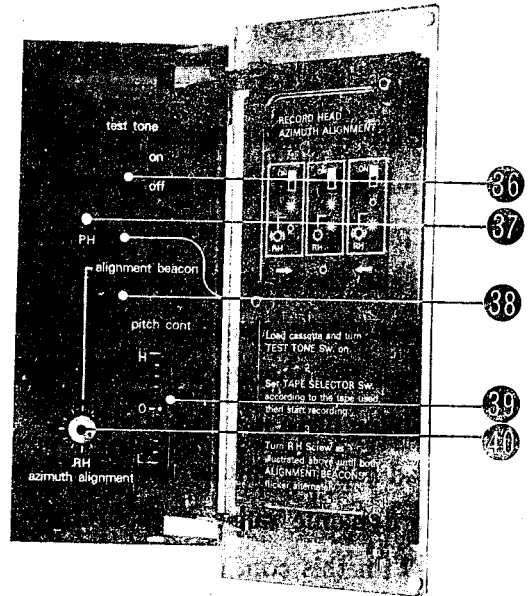

Fig. 1.3. (Adjustment Panel)

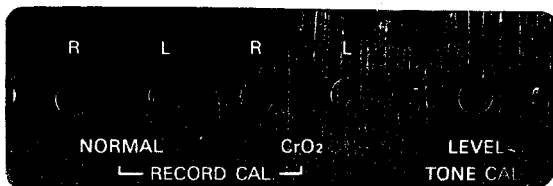

Fig. 1.4. Dolby NR Level Calibration (Rear View)

- | | |
|--------------------------------|---|
| 1. Cassette Lid | 21. Mic Input Level Controls |
| 2. Playback button | 22. Blend Mic Level Control |
| 3. Stop Button | 23. Adjustment Lid |
| 4. Rewind Button | 24. Blend Mic Input Jack |
| 5. Fast Forward Button | 25. Mic Input Jack L |
| 6. Record Button | 26. Mic Input Jack R |
| 7. Pause Button | 27. Line Input Jacks |
| 8. Eject Button | 28. DIN IN/OUT Socket |
| 9. Headphone Jack | 29. Line Output Jacks |
| 10. Peak Level Meter | 30. Voltage Selector |
| 11. Tape Start Memory Switch | 31. Power Supply Cord |
| 12. Index Tape Counter | 32. Ground Terminal |
| 13. Adjustment Lid Button | 33. Remote Control Socket |
| 14. Tape Selector Switch | 34. 19kHz MPX Filter Switch |
| 15. Dolby NR Switch | 35. DIN Mic Input |
| 16. Limiter Switch | 36. Test Tone Switch |
| 17. Monitor Switch | 37. Playback Head Azimuth |
| 18. Power Switch | 38. Alignment Beacon |
| 19. Line Output Level Controls | 39. Pitch Control |
| 20. Line Input Level Controls | 40. Record Head Azimuth Alignment Screw |

2. PRINCIPLE OF OPERATION

2.1 MECHANISMS

2.1.1. 3-HEAD CONFIGURATION

Basically there are five openings in the cassette housing, and the both sides of openings are being used for left and right capstans and pressure rollers and the remaining three openings are for the two reference pins and the playback head in between. Nakamichi 1000 and 700 incorporate the 3-head system, and the playback head has a very narrow gap of 0.7 micron. In order to ensure the best possible frequency response particularly at the high-end the playback head should be positioned against the opening which will take advantage of the felt pad in the cassette housing as well as the shielding plate incorporated.

The record head gap is 5 micron wide for achieving the best bias and signal flux penetration to the tape and wide dynamic range in recording. The record head is of an exceptionally hard durable hi-Mu ferrite. With this configuration only the openings available for the separate erase and record heads are the openings of the take-up pressure roller side and the take-up reference pin side. One of the critical factors in the 3-head system is the adjustment of track width for the three independent heads. Instead of mounting the heads on the base plate of the mechanism the Nakamichi 1000 and 700 use a quite unique head mounting method; the three heads are hanged from the top of the head housing so that it enables an independent azimuth alignment on the three heads and the alignment becomes much easier since it can be performed with a screw driver from the top of the head housing. See Fig. 2.1. If readjustment of the heads is necessary, it is highly recommendable to do the adjustment, referring to the Adjustment Procedures.

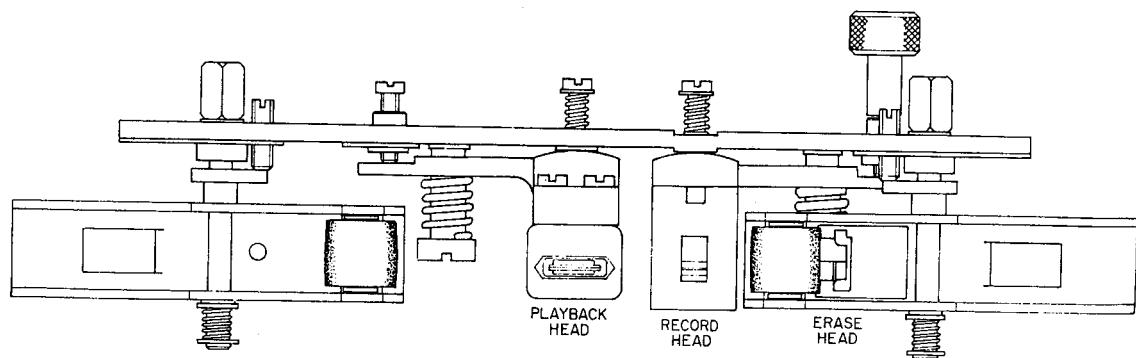

Fig. 2.1 Head Housing

2.1.2. DOUBLE CAPSTAN TAPE DRIVE

As shown in Fig. 2.2, the double capstan system consists of two capstan shafts (a) and (b) connected to the two flywheels which are driven with a belt.

Against these capstans two pressure rollers (a) and (b) are engaged to run the tape with an adequate holdback tension created by the double capstan and pressure rollers. When the two capstan flywheels start rotating as shown in Fig. 2.2 the belt tension at side A becomes stronger than that of the side B belt and the rotation of capstan (a) becomes slightly faster than that of the capstan (b). With the pressure rollers (a) and (b) pressed against the capstans (a) and (b) it creates a tension over the tape between the capstans in proportion to the difference in capstan rotation.

As the double capstan system always creates a constant and stable holdback tension between the two capstans, the condition of the tape between two capstans will not be affected by any external conditions such as irregular take-up and supply torque, irregular load of cassette tape, undesirable mechanism vibration, etc., thus assuring the superior wow and flutter characteristic.

The double capstan system provides a constant holdback tension on the tape and maintains the stable pressure on the tape against the heads, therefore, the tape maintains the stable contact against the erase and record head surfaces even without the pads.

The only critical factor in the double capstan system is to be considered; the two capstans have to be positioned perfectly in parallel and to be precisely vertical against the head base, the pressure rollers have to be evenly pressed against the capstan shafts and the head surface must be positioned perfectly vertical against the tape surface. Otherwise, it occurs that the running tape will be out of the tape guide resulting in the irregular tape movement.

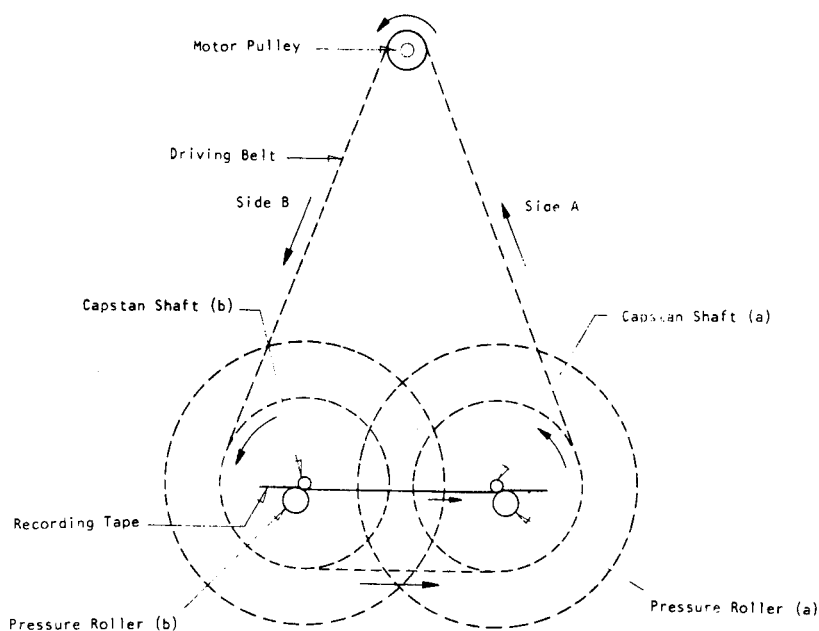

Fig. 2.2 Double Capstan System

2.1.3. REEL DRIVE MECHANISM

Play Mode:

Refer to the Fig. 2.5 and 2.4.

At power switch on main motor begins to rotate, and pulley "f" and pulley "g" will turn to the indicated direction through belt "e".

At play mode, head base is slidden and pin "a" which is locked by head base cam becomes free.

Then spring "b" acts to let pulley "g" contact take-up pulley side.

There is a clutch mechanism between pulley "g" and take-up pulley as shown in the Fig. 4. Take-up pulley will rotate through clutch mechanism.

Fast Forward and Rewind Mode:

Refer to the Fig. 2.3 and 2.4.

Pulley "m" moves freely either toward the supply pulley or take-up pulley. Only while play mode pin "k" is locked by slidden head base and pulley "m" does not move.

While fast forward mode, belt "i" and pulley "l" will turn to the indicated direction.

Pulley "m" is turned by pulley "l" and pressed to the take-up pulley directly.

Pulley "m" has a tension mechanism itself and it acts to generate mechanical loss therefore the force which will press the pulley "m" to the take-up pulley happens.

At time of rewind mode, belt "i" will turn to the opposite direction and pulley "m" will be pressed to the supply pulley.

Spring "j" acts to press pulley "m" toward the pulley "l".

At a tape end belt "i" will stop through clutch mechanism which is assembled to the sub-motor.

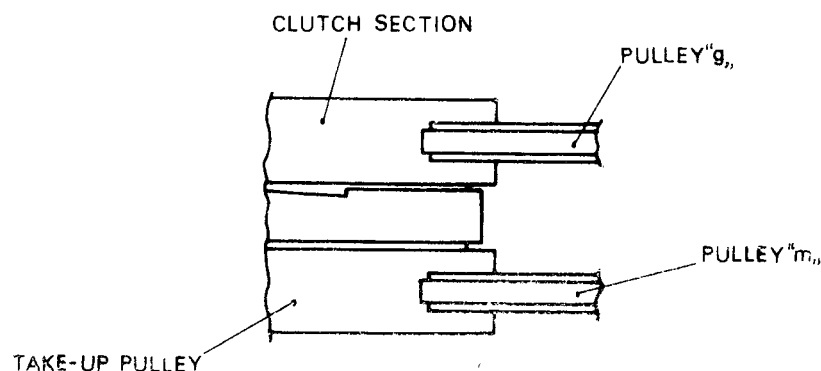

Fig. 2.4 Clutch Mechanism

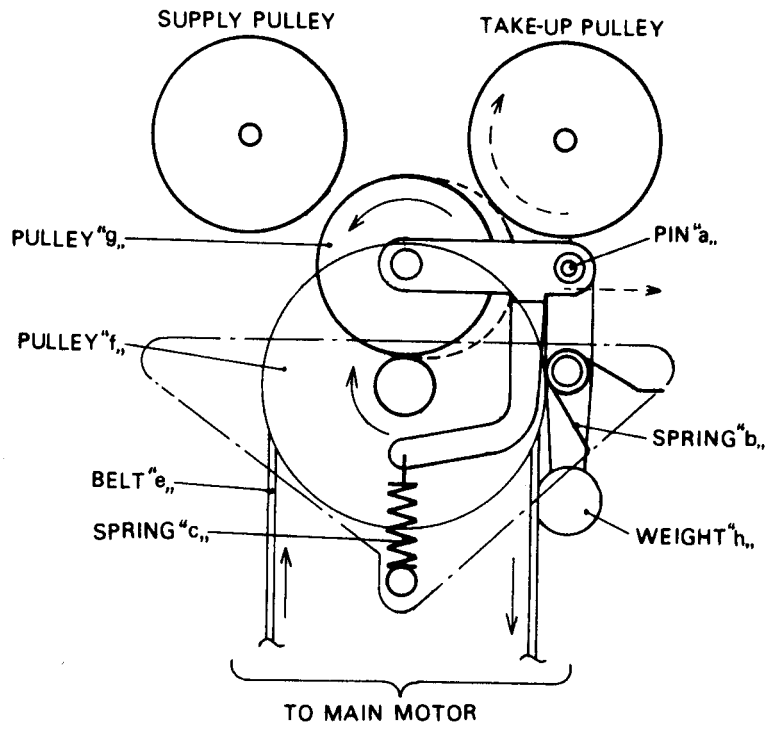

Fig. 2.3 Play Movement

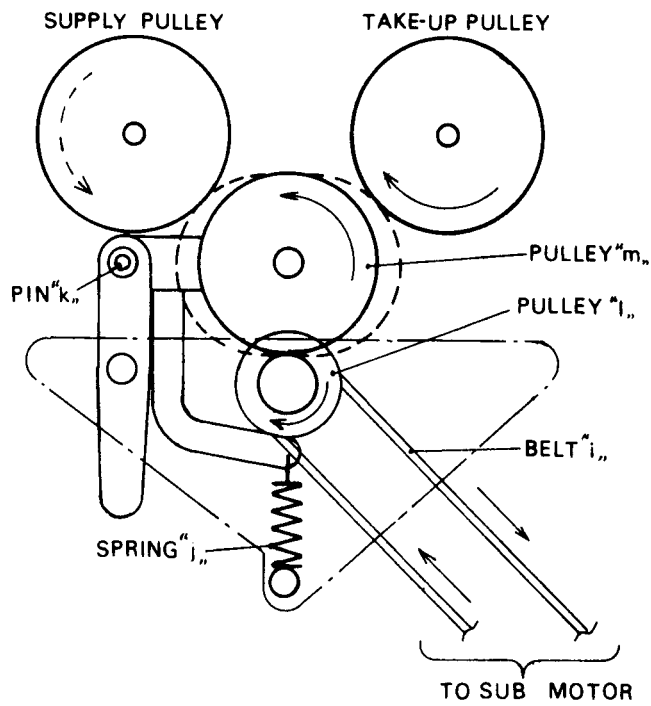

Fig. 2.5 F.Fwd & REW Movement

2.2. AMP. CIRCUITS

2.2.1. REC. DOLBY CIRCUIT

Fig. 2.6 shows a recording mode Dolby processor circuit. The circuit input signal is applied through terminal 11(4), while the signal applied through terminal 12(3) is fed to the MONITOR switch and LIMITER circuit and is only subjected to impedance conversion by Q101 and is not boosted by the Dolby processor. Terminal 10(5) is the circuit output terminal and is linked with the REC. EQ. AMP via REC. CAL. VR and TAPE selection switches. Terminal 13(2) is connected with the DOLBY NR switch. For DOLBY NR IN, this terminal is open and a feedback current is applied to the base of Q102. For DOLBY NR OUT, this terminal is grounded and the output via the emitter of Q102 is cut from the Dolby processor.

A detailed explanation of the Dolby processor can be found in other references, however, it is also briefly described here.

Fig. 2.7 compares input vs. output characteristics of the Dolby processor, where curve A shows the recording mode Dolby circuit and curve B the playback mode. The symmetry of these two characteristics with respect to line 0-0', bisecting the right corner, is highly significant.

Curve A for recording exhibits a linear relationship between the input and output signal levels from the high level down to -5 dB, under which the input level gradually bends. For input levels under -30 dB, the output level is boosted by 10 dB with respect to the input level. The action of the recording mode Dolby circuit is that the output level is boosted from 0 to a maximum of 10 dB according to the input level.

With curve B for playback, in contrast to that for recording, the output level decreases with a decrease in the input level and, for an input level of less than -30 dB, becomes a further 10 dB lower than this input level. According to this characteristic, noise generated in the playback system, such as hiss noise, playback amplifier noise, etc., is reduced by 10 dB. Combination of the above for recording and playback mode results in a linear characteristic. For example, for a -40 dB recording input, point b on curve A is recorded at -30 dB since the input is boosted by 10 dB in the recording mode Dolby circuit. When the signal reproduced from a recorded magnetic tape enters the playback mode Dolby circuit, the -30 dB input level is reduced by 10 dB to -40 dB; point b' on curve B. Thus, the 1:1 proportional relation is valid for any input level.

This action is explained using a system diagram of the recording mode Dolby processor as shown in Fig. 2.8.

The input signal enters the input of amplifier 4 (Q102) via amplifier 1 (Q101). Another signal from amplifier 1 is amplified by amplifier 2 (Q104 and Q105) after passing through a high-pass filter and enters amplifier 4. This signal is superposed by another signal as previously mentioned and this added signal is supplied to the output terminal through amplifier 4. The signal amplified by amplifier 3 (Q106) is fed back to an FET (Q103) after being rectified by diode D(D104). A circuit including the high-pass filter, amplifiers 2 and 3, and the FET in Fig. 3 is called a compressor, and

the signal which appears at the point between the output of amplifier 2 and the input of amplifier 4 is called the compressor output signal (E_2). On the other hand, the output (E_1) of amplifier 1 is called the direct signal, and the FET is used as an electronic attenuator.

Indications such as 8.2V, etc. in the circuit diagram show DC voltages when a zero signal is applied. The standard input signal level to the recording mode Dolby processor is 400 Hz and 100 mV. The recording output signal level is about 85 mV (r.m.s.).

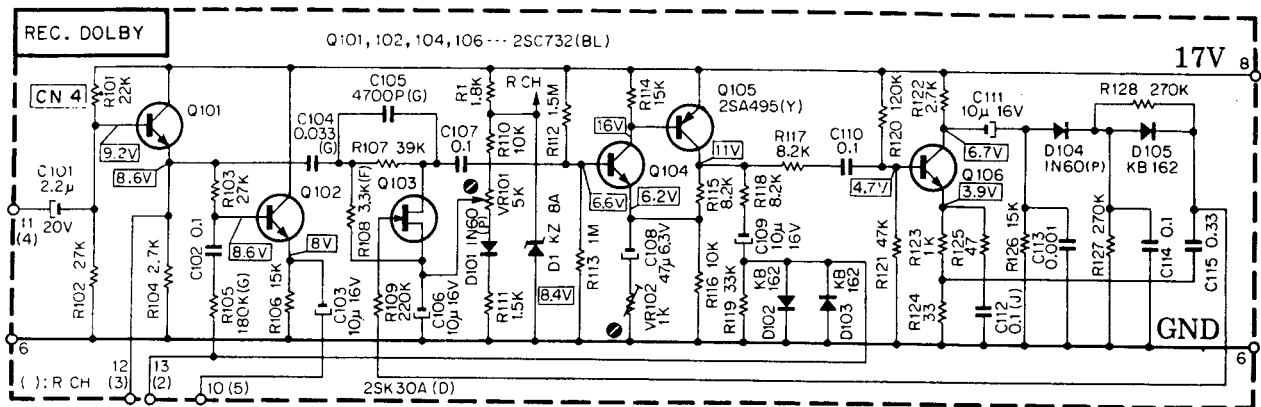

Fig. 2.6 Record Dolby Processor Circuit Diagram

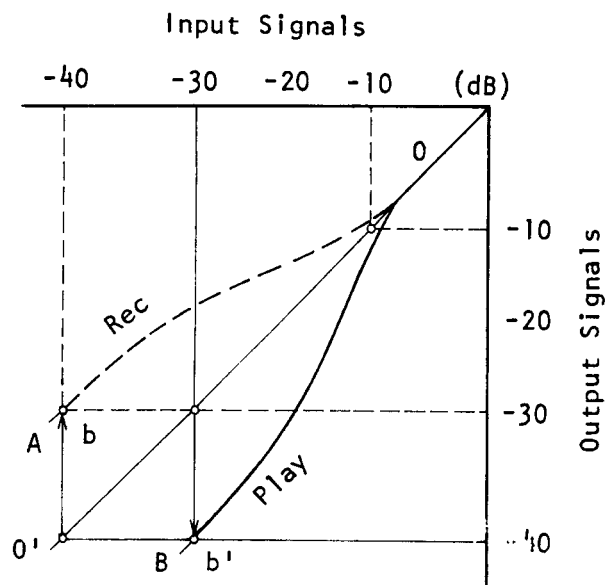

Fig. 2.7 Working Principle of Dolby Circuit

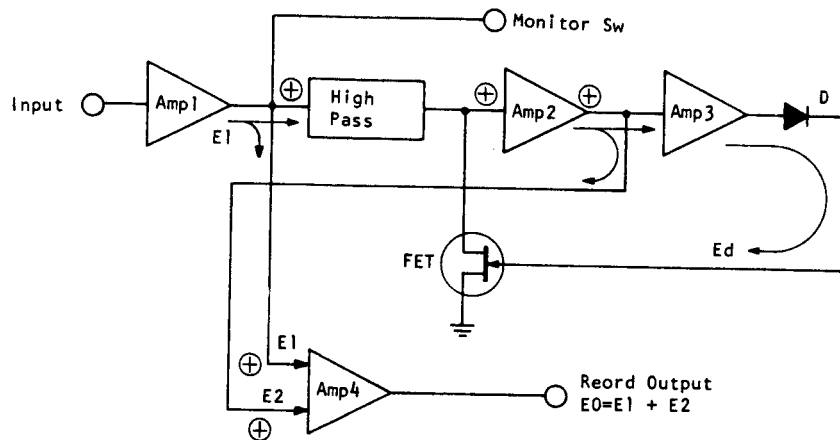

Fig. 2.8 Record Dolby Processor System Diagram

2.2.2. P.B. DOLBY CIRCUIT

Fig. 2.9 shows a circuit diagram for a playback mode Dolby processor. The input for this circuit is applied through terminal 12(3) where the output of the playback head amplifier is connected. Terminal 10(5) is the output of the playback mode Dolby processor which becomes the input of the DNL circuit via the MONITOR switch. An input signal through terminal 13(2) is applied to the DOLBY NR switch. For DOLBY NR IN, this line is open and the signal is fed back to the base of Q101. For DOLBY NR OUT, this line is grounded and no signal is fed back.

Since the general action of the Dolby processor was described in the preceding section, REC. DOLBY CIRCUIT, only the action of the playback mode Dolby processor will be explained here, using its system diagram. The input signal applied through amplifier 1 (Q101, Q102) via a high-pass filter, is amplified in amplifier 2 (Q104, Q105), and is then fed back to the input of amplifier 1 in opposite phase to the phase of the input signal. Since this results in the subtraction of the feedback signal from the input signal, the resultant signal appears at the amplifier 1 output, i.e., the playback mode Dolby processor. Meanwhile, an output signal which has been amplified by amplifier 3 (Q106) controls the FET (Q103) after being rectified by diode D (D104).

The difference between playback and record is, as is obvious from the above explanation, that the phase of the compressor signal is opposite to that of the direct signal because of the changed signal path. Fig. 2.11 shows typical record and playback mode frequency characteristics for the Dolby processor. According to this figure, it is obvious that frequency components higher than about 200 Hz are subjected to the Dolby process at levels less than about -10 dB.

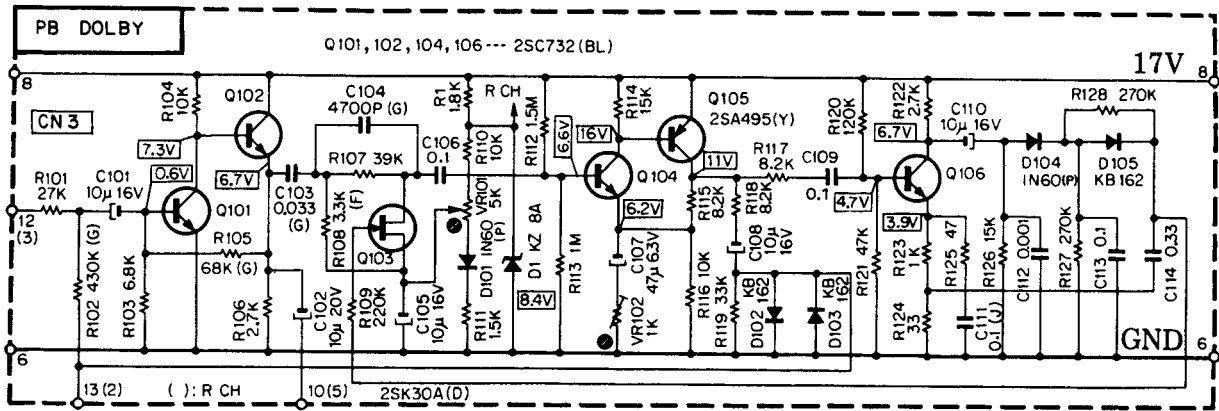

Fig. 2.9 Playback Dolby Processor Circuit Diagram

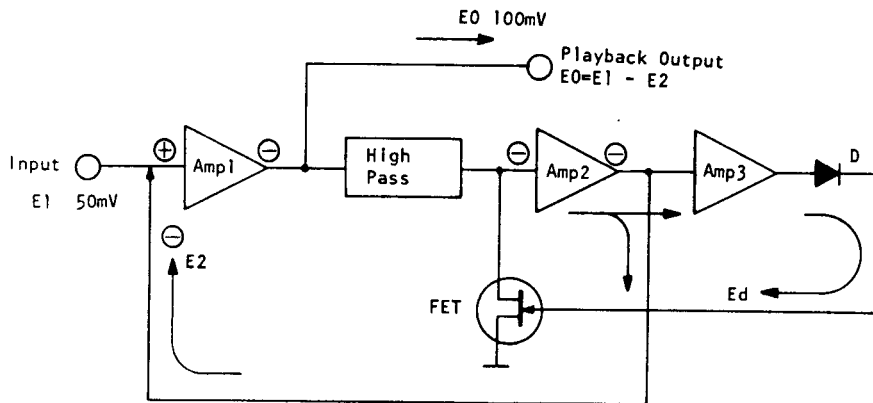

Fig. 2.10 Playback Dolby Processor System Diagram

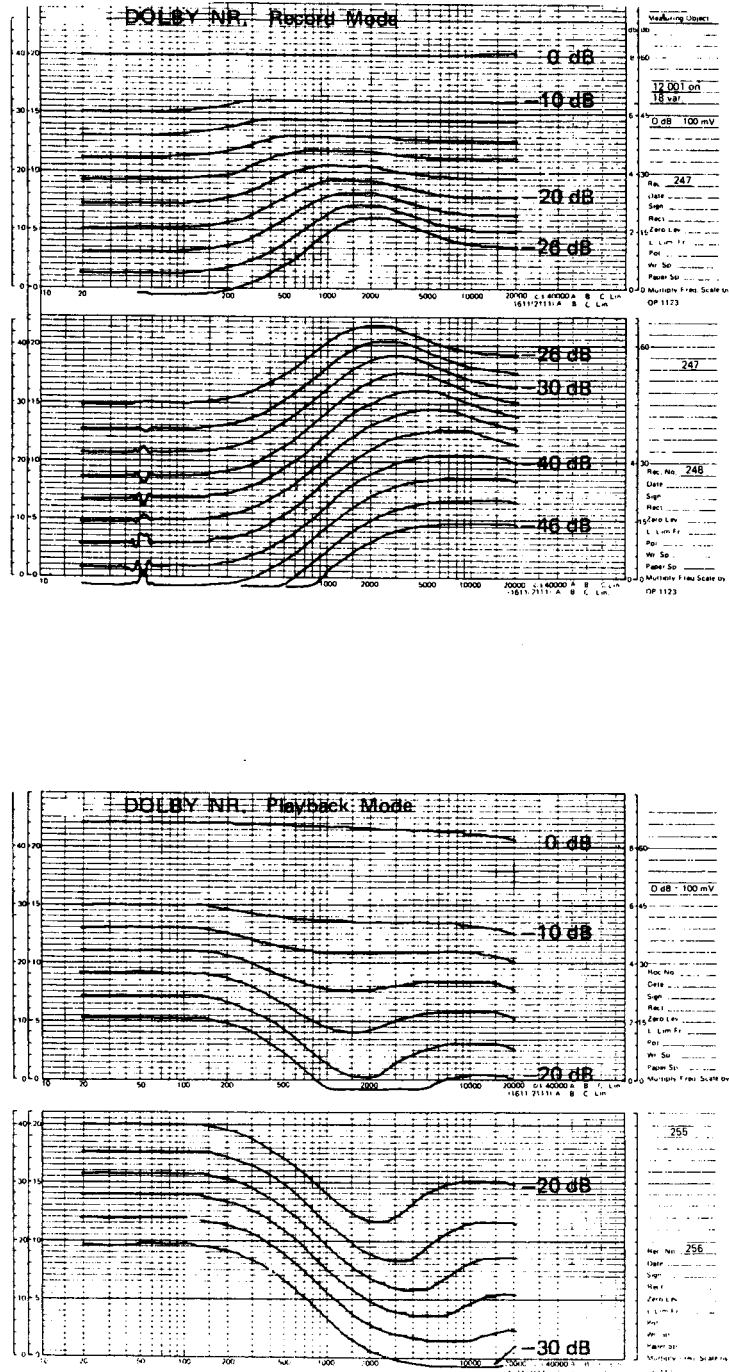

Fig. 2.11 Dolby Processor Frequency Response

2.2.3. P.B. HEAD AMP.

Fig. 2.12 shows the playback amplifier circuit, and Fig. 2.13 is its system diagram. The playback head is connected with terminals 13 (11) and 14 (12). Terminal 4 is provided for the mute signal. Terminals 8 (6) and 9 (7) are connected with the TAPE switch which is used to select a time constant according to the characteristics of the magnetic tape used.

Amplifier 1 (Q101 and Q102) is an equalizer amplifier. With the selection of the equalizer constants of its feedback circuit by means of a jumper wire, its time constant on the high frequency side can be varied in 10 μ s steps from 110 μ s to 140 μ s and its gain in 1 dB steps. This selection is provided for compensation of playback head characteristics, however, the time constant of 120 μ s is usually selected by short-circuiting R₁₁₀ (18 k Ω) and opening R₁₁₁ (39 k Ω).

Time constants of the time constant circuit are selected by NORMAL and CrO₂ positions of the TAPE switch so that the frequency characteristics of the circuit will fit those of the magnetic recording tape used as follows:

NORMAL 1590 μ s (100 Hz) + 120 μ s (1326 Hz)

CrO₂ 3180 μ s (50 Hz) + 70 μ s (2275 Hz)

The FET (Q103) acts to prevent transference of the amplifier 1 output signal to amplifier 2 (Q104 and Q105) by reducing its gate voltage below the pinch-off voltage for the mute signal. The playback amplifier gain is adjusted by VR101 in amplifier 2 so that, when the 400 Hz 20 mM/mm recorded tape is played back the output voltage of the playback mode Dolby processor at terminal 10(5) becomes 100 mV and that of the playback head amplifier at terminal 3(2) about 50 mV.

The L and C in the amplifier 2 output provide a filter for bias-trapping which prevents disturbance of the Dolby action due to mixing bias frequencies in the Dolby processor.

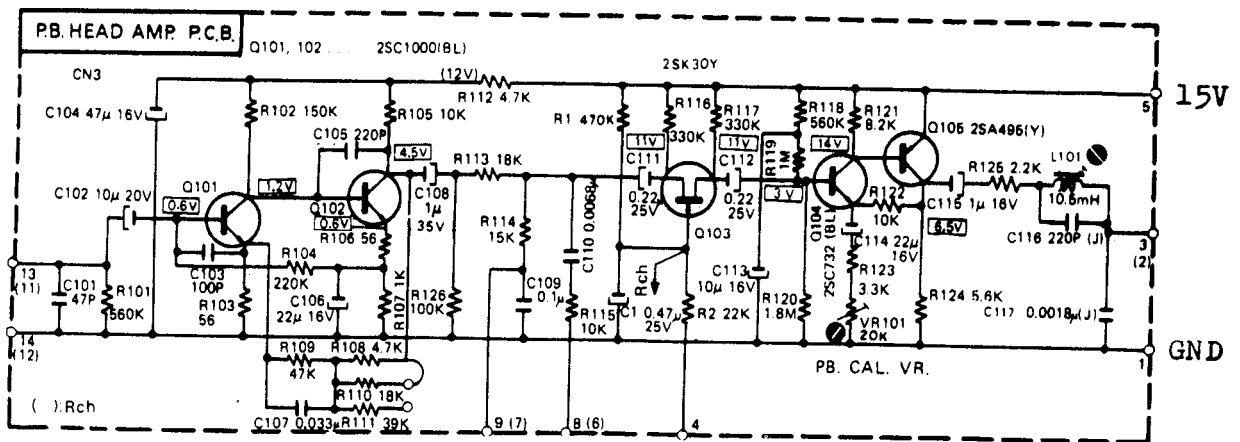

Fig. 2.12 Playback Amp. Circuit Diagram

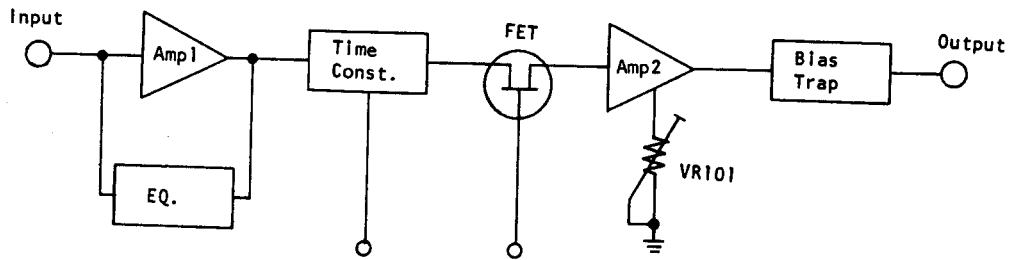

Fig. 2.13 Playback Amp. System Diagram

2.2.4. MIC AMP.

Fig. 2.14 shows a microphone amplifier circuit. This circuit board carries a DIN amplifier (DIN AMP.), a microphone amplifier (MIC AMP.) and a blending microphone amplifier (BLEND MIC AMP.). The DIN connector and pin connector are communicated to the LINE VOLUME directry. When pin connector is used, disconnect the DIN cord for avoiding the influence of the DIN cord stray capacitor.

Microphone amplifier (MIC AMP): Since the signal level of this input is usually low, Q702 is provided to broaden the dynamic range. This circuit is a modified shunt regulated push-pull system which is devised for varying the load of Q701 with the position of the MIC VOLUME control. For a large microphone output, this circuit is used at a reduced MIC VOLUME. In this case, however, the voltage gain of Q701 decreases because the load resistance of Q701 is reduced. Since voltage gain of the conventional microphone amplifier is constant, its amplification characteristics are not good for large input signals and its dynamic margin is about 40 dB. However, the microphone amplifier described here can be used without distortion for input voltages up to 0.5V because of its broad dynamic margin which is greater than 60 dB. Thus, no microphone attenuator is necessary. If neither a DIN microphone nor a microphone plug are connected, the output of this circuit is grounded.

As the blending microphone circuit (BLEND MIC) is the same as the microphone amplifier, its explanation is omitted.

The voltage values indicated as 0.5 mV, 10 mV, etc., at the input terminals of the circuit board show that when each VOLUME control on the panel concerned is set at its maximum position, the LEVEL METER indicates 0 dB for each of these values. The output of this circuit is combined with the input of the mixing amplifier. The output impedance of this circuit is designed to be very high, above 270 k Ω , while the input impedance of the mixing amplifier of the next stage is designed to be low, therefore, with little interference between the VOLUME controls, ideal mixing is possible.

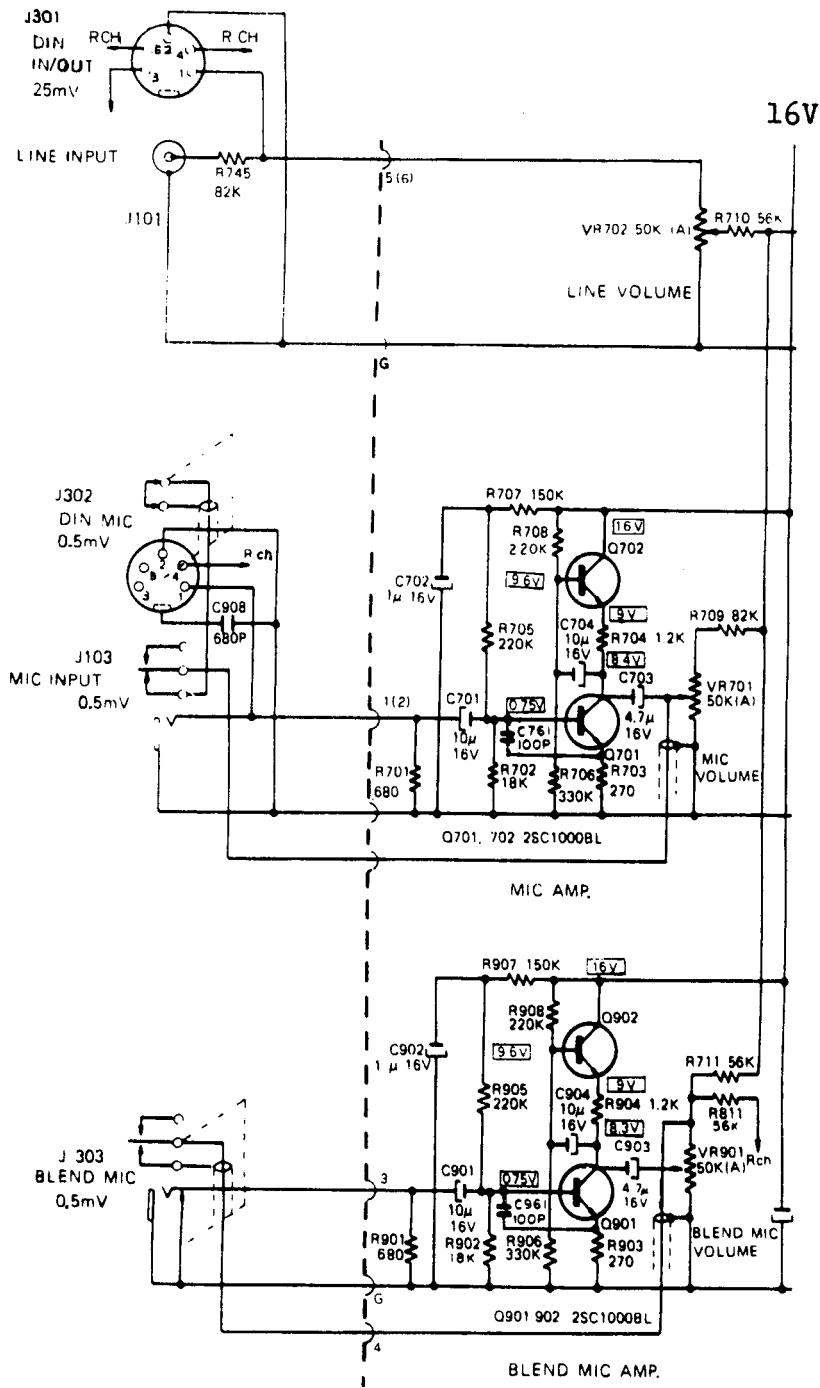

Fig. 2.14 MIC Amp. Circuit Diagram

2.2.5. MIXING AMP. AND LIMITER

Fig. 2.15 shows the circuits of a mixing amplifier (Q703, Q704), a multiplex filter (MPX FILTER), and a limiter (Q705 and Q706).

The output signal from the microphone amplifier board is amplified by Q703, and fed to the LC filter through an impedance conversion circuit which includes Q704. This filter normally operates the Dolby NR by removing the leakage of the bias signals for recording and the FM broadcast multicarrier signals. L102 is adjusted to minimize the 19 kHz signal level for MPX switch IN. The output of this circuit, 100 mV, becomes the input of the recording mode Dolby processor.

The input of the LIMITER circuit is linked with the output of amplifier 1 (Q703) of the recording mode Dolby processor. This signal is amplified by Q705, and enters the gate of the FET (Q706) after being rectified by diodes D701 and D702. When the LIMITER switch is set to OFF, Q706 is in the off-state and no limiter action is applied for the input of Q101, since condenser C712 is grounded. By setting the switch to ON condenser C712 becomes charged and Q706 is in ON state. This results in the operation of the limiter.

When unexpectedly large peaks of transient noise enter during recording at a marginal level, the peak limiter promptly operates to control recording amplifier gain.

When signals with levels higher than +3 dB enter, part of the signal in excess of +3 dB is compressed to one-seventh its magnitude, as shown in Fig. 2.16. Therefore, over-recording is avoided even if an input signal as large as +20 dB enters. Since the attack time and the release time of this limiter are 1 ms and 2 sec, respectively, no hearing imbalance is detected.

Fig. 2.16 shows the characteristics of the limiter.

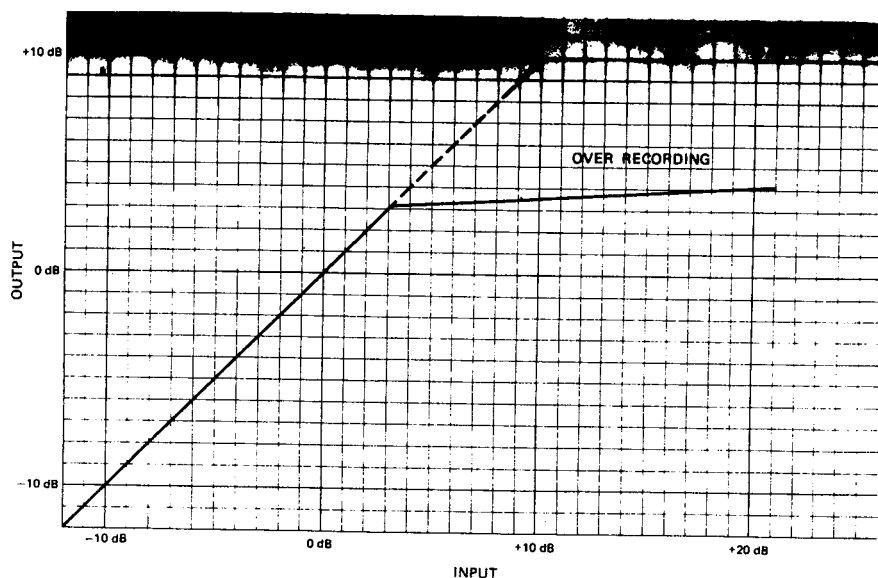

Fig. 2.16 Limiter Characteristics

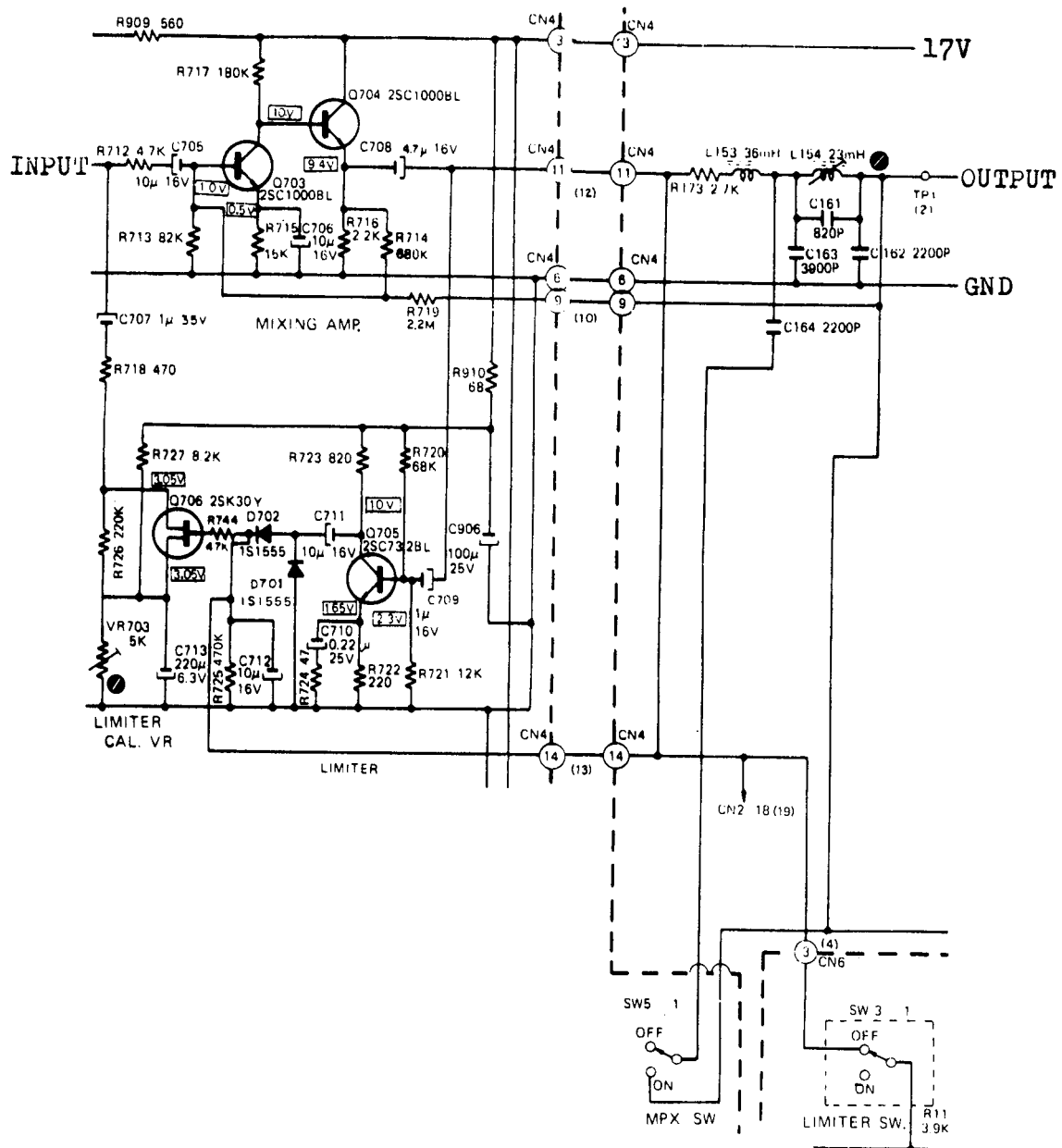

Fig. 2.15 Mixing Amp. and Limiter Circuit Diagram

2.2.6. REC. EQ. AMP.

Fig. 2.17 shows the recording calibrator variable resistor circuit (REC. CAL. VR) and the recording equalizer amplifier circuit (REC. EQ. AMP.).

This signal from the output of the recording mode Dolby processor becomes the input of this RECORDING CALIBRATOR circuit. The recording head (REC. HEAD) is connected between the output terminal of this circuit and the ground. (A 10 Ω resistor is inserted in series on the ground side.)

The VR 152 line is prepared for NORMAL tape and that of VR 151 for CrO₂ tape. The time constant is selected by changeover of this TAPE switch. This selection, coupled with the time constant selection in the Playback Head Amplifier (P.B. HEAD AMP.), makes it possible to obtain characteristics suitable for tape types. With respect to the details of this part, the reader should refer to the section on the playback head amplifier.

Since the FET (Q151) is in the OFF state for mute, the signal is cut here and no signal exists in the equalizer amplifier circuit. Without the mute signal, Q151 is in the ON state. Thus, the signal from the RECORDING CALIBRATION is amplified by Q152 and Q153. And a constant current flows through the RECORDING HEAD over all frequencies used. L151 and C158 compose the recording equalizer. Compensation for the high frequency range is made by building a resonance frequency at about 23 KHz by means of adjusting L151, L152 and C159 construct a bias trap.

Fig. 2.18 and 2.19 show the frequency characteristics for recording and playback.

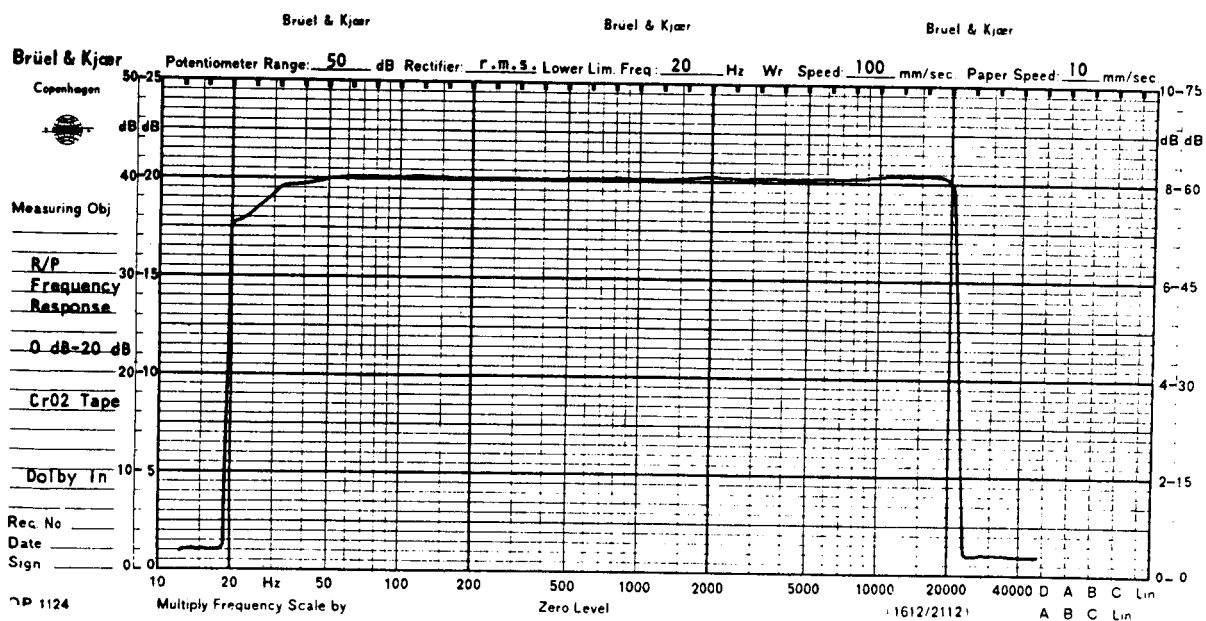

Fig. 2.18 Record/Playback Frequency Response (Dolby NR In)

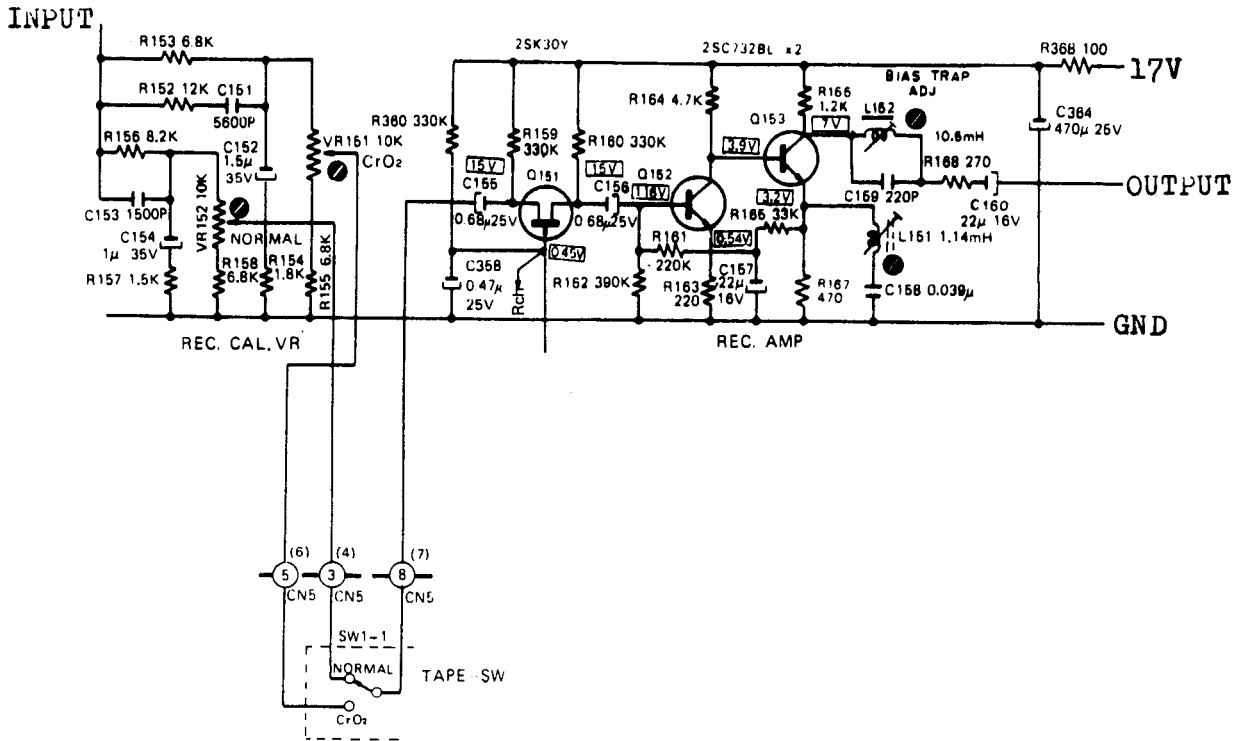

Fig. 2.17 Rec. EQ. Amp. Circuit Diagram

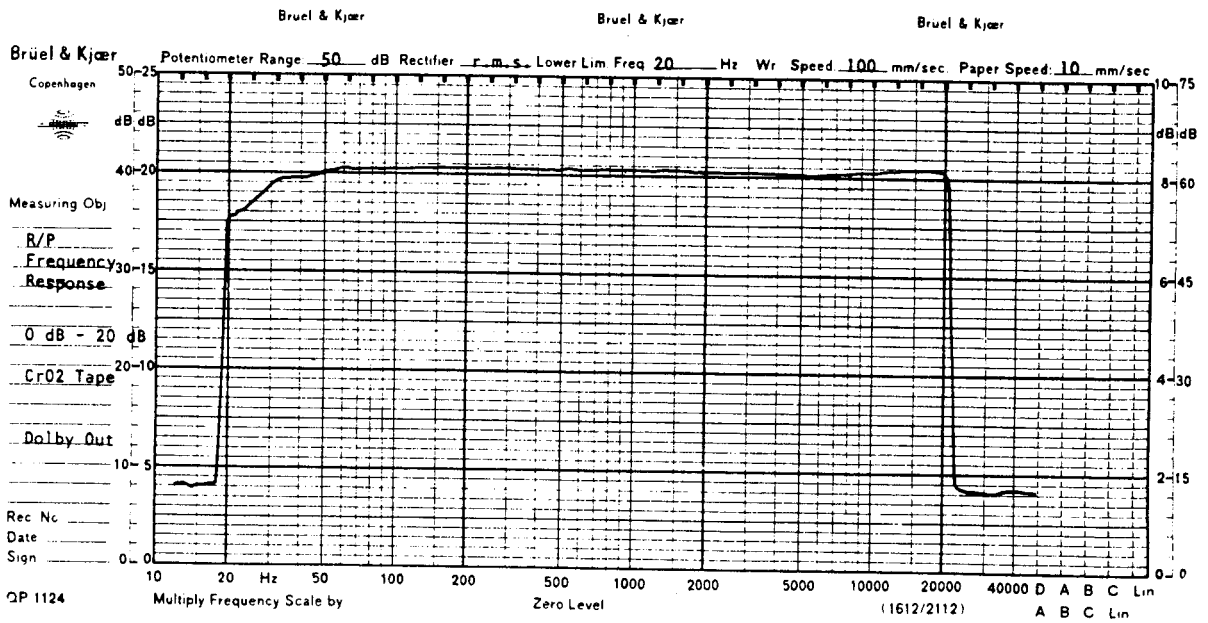

Fig. 2.19 Record/Playback Frequency Response (Dolby NR Out)

2.2.7. BIAS OSC. AND 400Hz OSC.

Fig. 2.20 shows a push-pull oscillator with an oscillation frequency of 105 KHz which is constructed by capacitors C353 and C354 decoupling the collectors and bases of two transistors.

This is used to provide recording bias and as an erase signal.

By depressing the REC. button, the Rec. signal turns to high through the logic board, Q354 is put in the ON state, the bias oscillator power supply is activated, and oscillation begins. When the record mode is released, oscillator output is damped by the discharge of C351. This prevents magnetization of the head.

Fig. 2.21 shows a 400 Hz oscillator circuit using an LC circuit. Its signal output is used to check record and playback levels and as an alignment beacon. VR351 is used for adjusting oscillation amplitude.

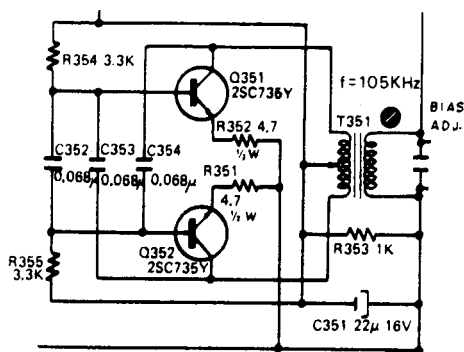

Fig. 2.20 Bias Osc. Circuit Diagram

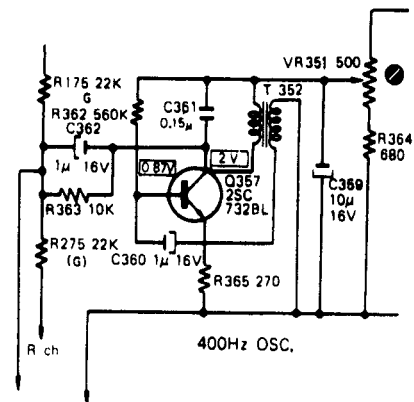

Fig. 2.21 400Hz Osc. Circuit Diagram

2.2.8. LINE AMP. AND METER AMP.

Fig. 2.22 shows the level meter amplifier circuit and the line output amplifier. Terminal CN4-4(5) is the input of the level meter amplifier.

Q154 and Q155 form a directly coupled feedback amplifier and for a low input level, feedback occurs through R180. For high input levels which exceed the Zener voltage of diode D152, feedback magnitude increases by adding a feedback through R181 to that through R180, and the output gain decreases. That is, high input signals are subjected to compression during amplification. This circuit is so designed that its attack time is 20 μ s and its release time is about 140 msec, thus, even if sharp peaks such as those encountered in live music exist, the level meter indicates correct peak values.

The input of the line output amplifier is connected to the MONITOR switch and its level is controlled by the OUTPUT VOLUME control. The signal amplified by Q707 and Q708 is fed to an emitter follower circuit composed of Q711, and a maximum output of 1000mV is obtained from line terminal. Since the output impedance is low, long cords are available for connection and no deterioration of characteristics occur due to multiple connections to recorders, etc. A circuit composed of Q710 and transformer is designed for a headphone with an 8 ohm impedance.

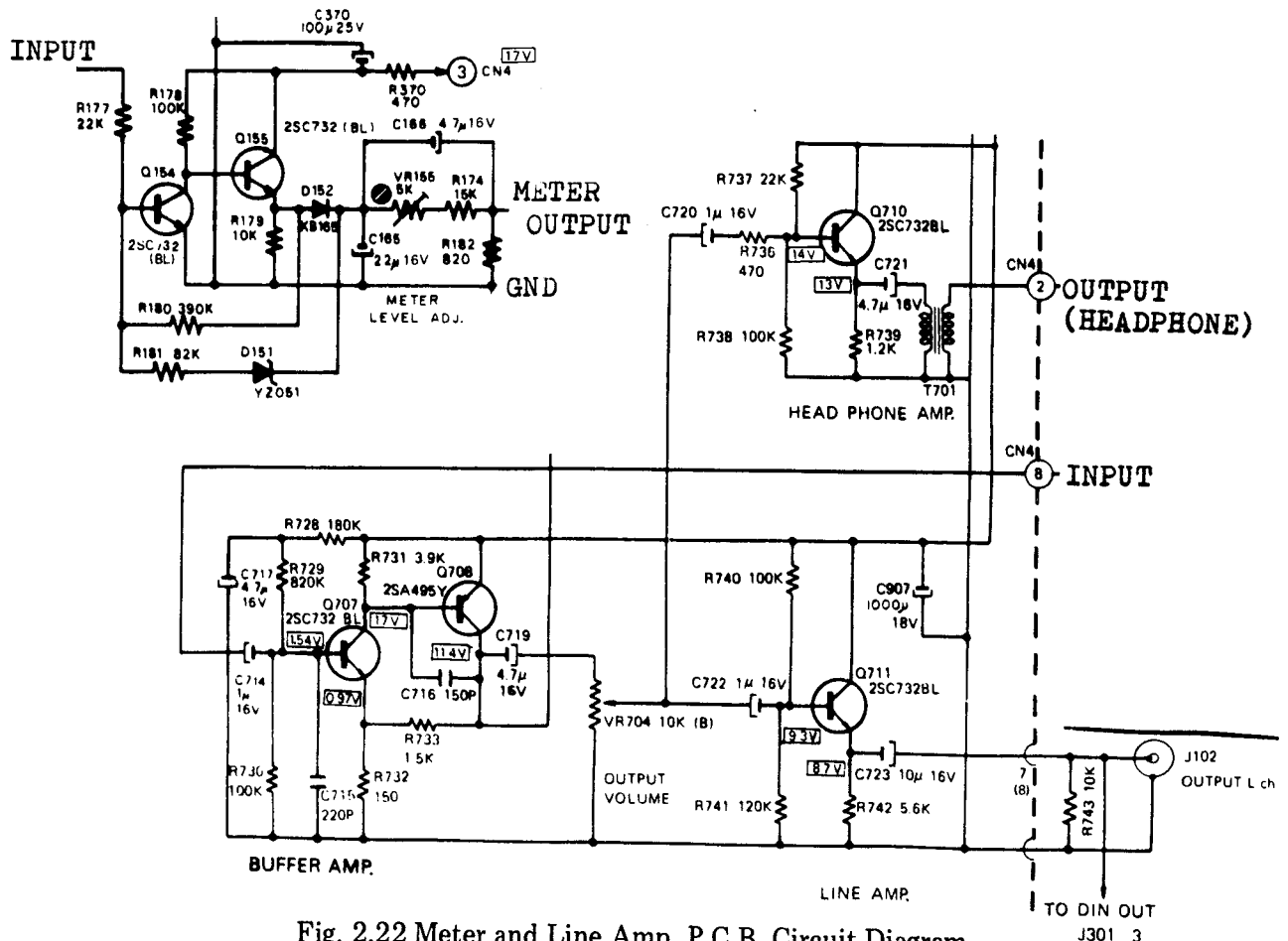

Fig. 2.22 Meter and Line Amp. P.C.B. Circuit Diagram

2.2.9. POWER SUPPLY

Fig. 2.23 shows the power supply circuit. This power supply is designed so that a constant voltage is obtained at the output on the secondary side of transformer [T₁] for 100–117V/220–240V AC inputs by changing the VOLTAGE SELECTOR plug.

The 17V DC, 0.5A output is used as a power supply for the amplifier system, and the 12V DC, 1.5A output for the mechanism control. The 6V AC, 0.3A output is the power supply for illuminating the level meter.

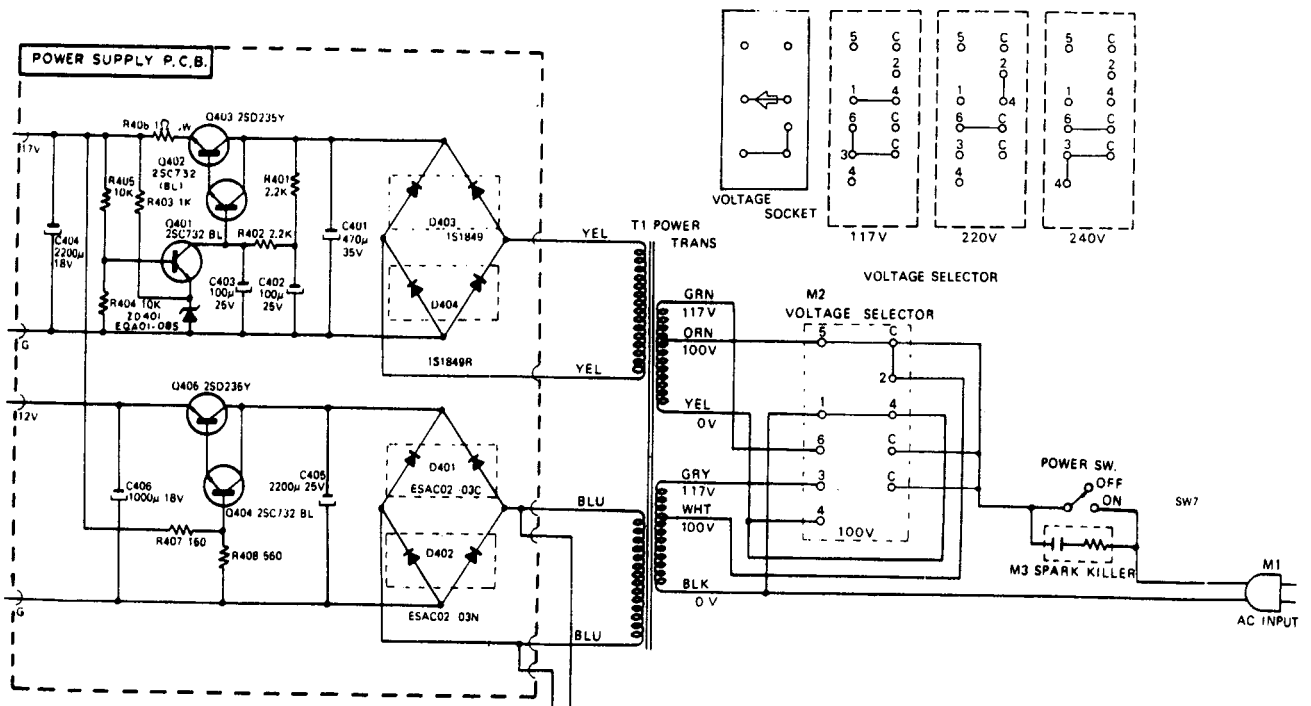

Fig. 2.23 Power Supply Circuit Diagram

2.3. MECHANISM CONTROL CIRCUITS

The Mechanism Control Circuits consist of a logic control, shut-off control, azimuth alignment detector and motor governor. Refer to the Fig. 2.24 "Mechanism Control Overall Block Diagram".

2.3.1. LOGIC CONTROL

(1) General

The commands from front panel control buttons are communicated to the logic control circuits.

Logic outputs are connected to the delay circuits and drivers for control of mechanisms.

Logic circuits consist of TTL ICs the details of which are as follows:

a. Main characteristics of TTL IC

Supply voltage	5V
Logical L output voltage	less than 0.5V
Logical H output voltage	3V to 4V
Noise immunity	1V
Temperature range	0° to 70°C

b. Gate Logic

The inputs are IN1, IN2 and IN3, and the output from the gate is shown below:

The output will be a L only if IN1 and IN2 and IN3 are all H's, and the output will be a H if IN1 is a L or IN2 is a L or IN3 is a L.



$$\text{Out} = \overline{\text{IN1} \cdot \text{IN2} \cdot \text{IN3}}$$



$$\text{Out} = \overline{\text{IN1}} + \overline{\text{IN2}} + \overline{\text{IN3}}$$

Truth Table

IN 1	IN 2	IN 3	Out
L	L	L	H
H	L	L	H
L	H	L	H
H	H	L	H
L	L	H	H
H	L	H	H
L	H	H	H
H	H	H	L

$$\text{Out} = \overline{\text{IN1} \cdot \text{IN2} \cdot \text{IN3}} = \overline{\text{IN1}} + \overline{\text{IN2}} + \overline{\text{IN3}}$$

The construction of the foregoing 2 Logic Symbols is identical and intended to show the use of either AND or OR.

c. Gated Flip-Flop

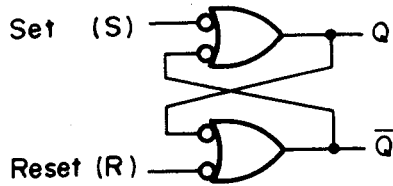

The two NAND gates can be used to form flip-flop.

The inputs operate as follows:

When both S and R are H's, the flip-flop will remain in its present state, i.e., will not change states. If however, the R input goes to a L, the NAND gate connected to R will have a H output regardless of the other feedback input to the NAND gate, and this will force the flip-flop to the L state (provided the S input is kept H). Similar reasoning shows that making the S input a L will cause the NAND gate at the S input to have a L output, forcing the flip-flop to the H state (again provided the R input is kept H).

If both inputs R and S are made L's, the next state will depend on which input is returned to H first, and if both are returned to H simultaneously, the resulting state of the flip-flop will be indeterminate. As a result, this is a "forbidden", or "restricted", input combination.

Truth Table

Set	Reset	Q	Q	Remarks
L	L	H	H	*) To maintain the previous state, but indefinite if both of the previous inputs S and R are made L's.
H	L	L	H	
L	H	H	L	
H	H	*	*	

In the actual use, the activation speed of the Flip-Flop is managed to be delayed in order to prevent erroneous movements caused by noise with details being as follows:

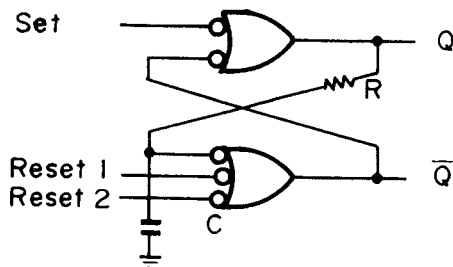

d. Schematics and Block Diagrams

SN7400N (Quadruple 2-input positive NAND GATE)

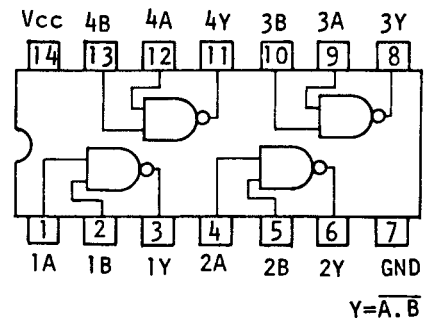
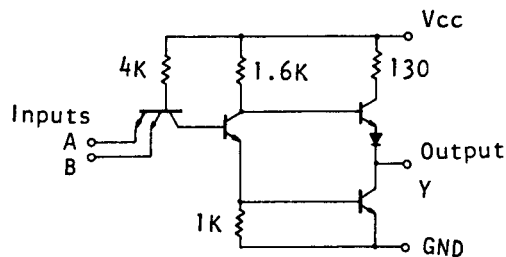

SN7410N (Triple 3-input positive NAND GATE)

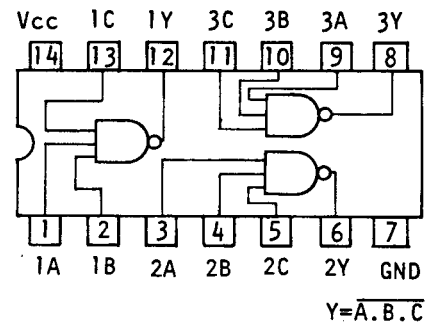
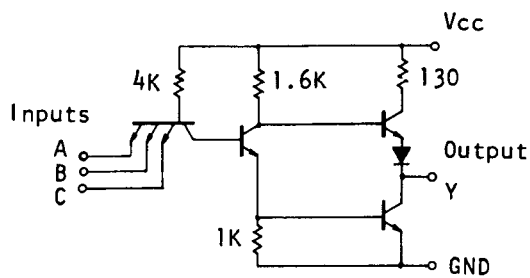

SN7420N (Dual 4-input positive NAND GATE)

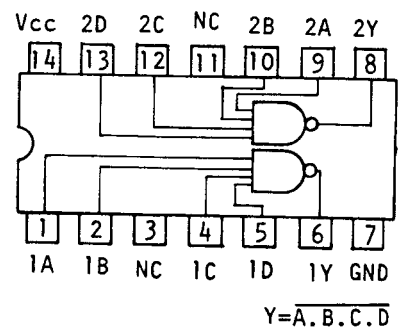
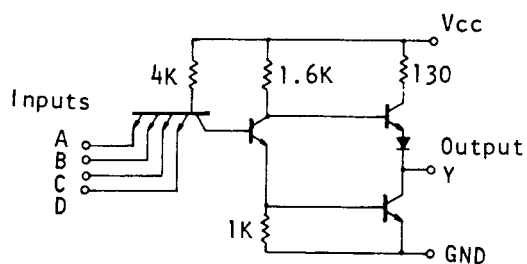

e. Compatible ICs

The following ICs belong to the same group which can be replaced:

L601, L603, L605:	N7400A, SN7400N, M53200P, HD2503, TD3400P
L602, L606	: N7410A, SN7410N, M53210P, HD2507, TD3410P
L604	: N7420A, SN7420N, M53220P, HD2504, TD3420P

(2) Logic Control

A foolproof operation will be done by logic control.

For example, when command the playback mode while fast winding or command fast-forward mode while rewinding, it is guaranteed that no abnormal tape tension will happen by passing through the stop mode. This is also guaranteed even when the buttons are pushed simultaneously.

a. Logic Signal

How to read the signals is referred to the following:

The signal $\overline{K\ stop}$ shows the condition that the signal is executing, and in case there is a — on the signal, signal L shows the condition that the signal is executing.

$\overline{K\ stop}$ (control stop button signal)

$\overline{K\ stop}$ becomes L when the stop button is depressed, and $\overline{K\ stop}$ is H while button is open.

\overline{PLY} (Play flip-flop \overline{Q} output signal)

$\overline{PLY} = L$ shows at play mode, and H shows out of play mode.

PLY (Play flip-flop Q output signal)

PLY = H shows at play mode, and L shows out of play mode.

$\overline{HB} = \overline{PLY \cdot Fst \cdot DL \cdot PAU}$

$\overline{HB} = L$ drive the head base plunger.

\overline{HB} signal becomes L when PLY = H AND Fst DL = L AND PAU = L.

b. Logic Operating Status

Refer to the figure 2 (Logic Status). Each stage of logic status is shown for the sequential control button command.

c. +5V Power Supply for ICs

+5V DC power supply is made by regulated +12V DC from the Power Supply Unit. The transistor Q610 acts as a regulator, being controlled by zener diode ZD601.

d. Initial Reset

At power switch On, +12V DC comes up gradually then the transistor Q609 and Q608 turn to On for only a certain period while Q609 base voltage is low with respect to the emitter (+5V).

And $\overline{K\ stop} = L$ pulse is generated.

At power switch Off, +12V discharges gradually, and $\overline{K\ Stop} = L$ pulse is also generated. $\overline{K\ stop} = L$ pulse clears each flip-flops and keeps at the initial condition, stop mode.

e. Stop Mode

The stop button when depressed makes $\overline{K\ stop} = L$ and resets each of the flip-flop. $\overline{K\ stop} = L$ pulse is generated when shut-off is detected and opens the cassette well and lowers +12V by 70%.

f. Play Mode (Playback or Record Mode)

The play button when depressed makes $\overline{K \text{ play}}=L$ and sets the PLY Flip-Flop, ($\text{PLY}=H, L605-8$), and head base plunger will be activated.

g. Record Mode

REC Flip-Flop (REC, L603-6) will be set to H when record button ($\overline{K \text{ rec}}=L$) and play button ($\overline{K \text{ play}}=L$) are depressed simultaneously, or record button and pause button ($\overline{K \text{ pau}}=L$) are depressed and then play button is depressed.

REC=H commands the bias oscillation of Amp.

Note: To close record protect switch is required.

h. Pause Mode

While recording or playback, the pause button when depressed sets the PAU Flip-Flop, PAU=H(L603-8).

Then \overline{HB} signal turns to H and head base plunger will be released.

i. Fast Wind Mode

The rewind ($\overline{K \text{ rew}}=L$) or fast forward button ($\overline{K \text{ ff}}=L$) when depressed sets the FST Flip-Flop.

While the $\overline{REW} / \overline{FF}$ Flip-Flop is set to $\overline{REW}=L$ (L606-12) or $\overline{FF}=L$ (L606-8), \overline{REW} or $\overline{FF}=L$ will drive the REW or FF Relay, and Reel Motor will turn backward or forward.

j. Mute Signal

$\overline{HB}=L$ or $\overline{PAU}=L$ makes Mute signal (L601-3) to H and will release the mute of the Amp.

(The mute of record Amp is released only at record mode, and playback Amp are released at record and playback modes).

k. Memory Stop

While memory switch is On and rewinding, stops tape travel when the tape counter comes to "999".

At counter "999", L606-12 ($\overline{REW}=L$) and capacitor C624 are connected, therefore the differentiated pulse is generated at L604-10.

This pulse resets Fst Flip-Flop turning to $\overline{REW}=H$, and stops rewinding.

(3) Drivers and Other Signals

a. Head Base Plunger

While set the PLY Flip-Flop, the head base plunger will be driven by the $\overline{HB}(L602-12)=L$.

However while in pause mode, the $\overline{PAU}(L602-2)=L$ will inhibit the $\overline{HB}=L$ signal.

The $\overline{Fst DL}$ (L602-1) signal will serve to drive the head base plunger after a certain period for stopping Fast Wind, when the play button is set to On during Fast Wind.

In this regard, the resistor (R680 15 ohm) connected to the plunger will be shorted by the Q627 and Q626 on the base switch P.C.B. Ass'y before the drive of head base and limit switch On.

b. Reel Motor

The FF Relay will drive while the $\overline{REW} / \overline{FF}$ Flip-Flop is $\overline{FF}=L$ and REW Relay being $\overline{REW}=L$.

One side of the Reel Motor is connected to the REW Relay and the other to the FF Relay, and the Relay is connected while Off the ground and while On +12V.

Rewind = REW Relay ON · FF Relay OFF

F · Fwd = REW Relay OFF · FF Relay ON

Stop = REW Relay OFF · FF Relay OFF

c. Brake plunger

Brake plunger is connected parallel to the Reel Motor.

Brake plunger is released when reel motor runs, and vice versa.

d. Lamps

Play Lamp — Lights on when head base plunger is set to On.

Record and Pause Lamps — Light on in the memory state of REC and PAU Flip-Flop respectively.

Rewind Lamp — Illuminates at Rew Relay On.

F.Fwd Lamp — Illuminates at F.Fwd Relay On.

Stop Lamp — Illuminates in the state other than the above.

e. Rec Signal

Rec signal connected to the Amp controls On/Off of the bias oscillation. Rec signal H conducts the bias oscillation.

The Rec and \overline{Rec} signals connected to the Pitch Control Volume serve in selecting the speed of the capstan motor for recording and playback.

f. Shut-off Detector Inhibition Signal

Prevents the shut-off signal from entering the Logic while the take-up reel is not turning.

Inhibition signal will be released by $\overline{HB} = L$ or $\overline{FST} = L$, namely while tape is travelling or in Fast Winding mode.

After $\overline{HB} = L$ or $\overline{FST} = L$ is commanded, it is considered as enough delay time to release shut-off inhibition signal for assurance of the stable start of the take-up reel movement.

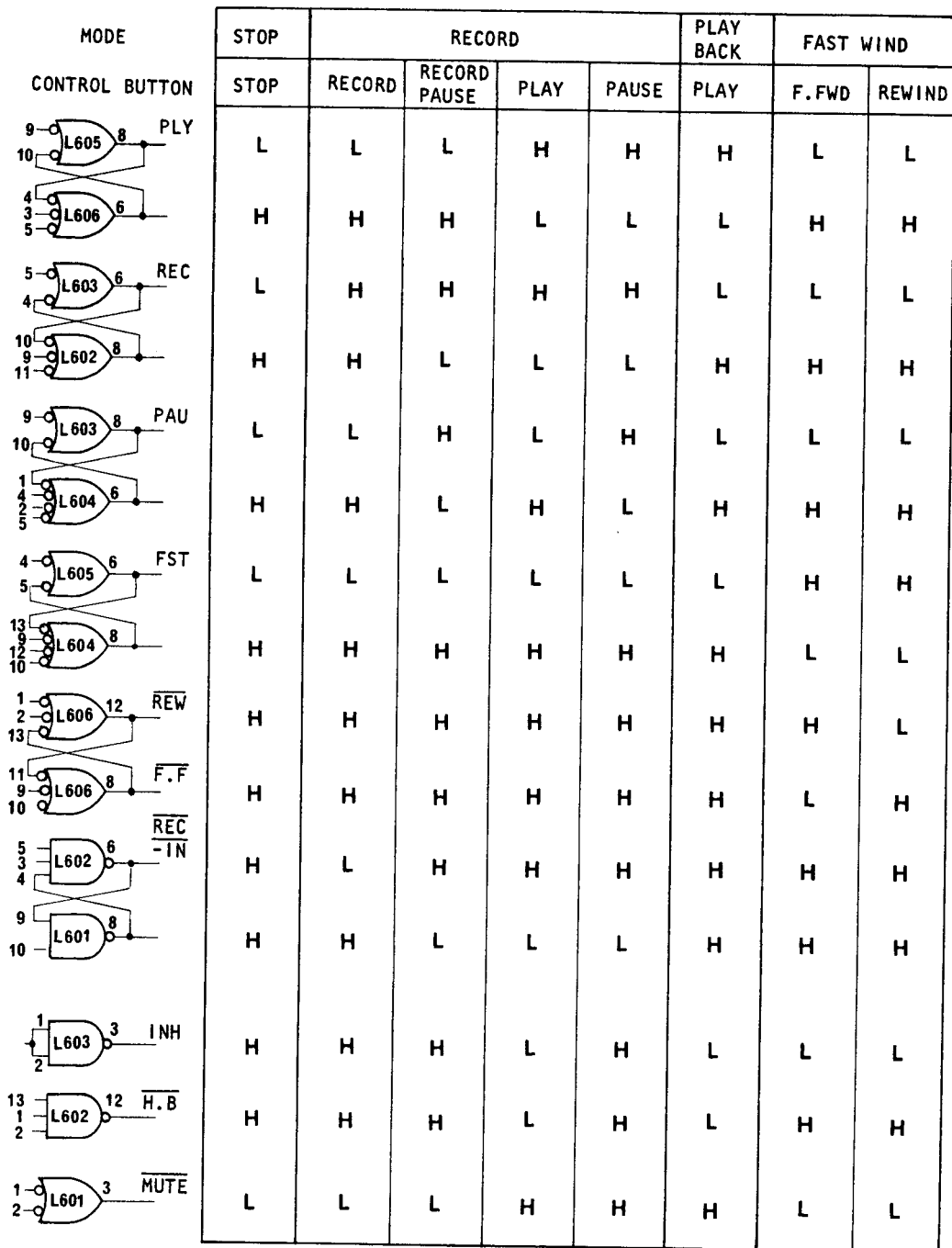

Fig. 2.25 Logic Status

2.3.2. SHUT-OFF SENSOR AND DETECTOR

Shut-off sensor consists of LED (Light Emitting Diode), photo transistor and slitted disc plate which is rotated by take-up reel.

Through turning disc plate, intermittent LED's lights are generated, while photo transistor is receiving these lights and output sensor signals. A shut-off signal which clears the Logic Flip-Flop will be generated when stop of sensor signals is detected by shut-off detector at a tape end.

- (1) The capacitor C611(0.12 μ F) is charged through resistor R622(1.8M ohm). While sensor output signals are differentiated by C610 and differentiated positive pulses set a transistor Q605 to On, then Q605 will discharge quickly.
- (2) At a tape end, sensor signal will not generate and C611 will be kept charged. When the voltage of C611 over the Q606 emitter voltage (about 2.3V) Q606 and Q607 turn to On, therefore Q608 turns to On and shut-off signal ($\overline{K\ stop=L}$) will be generated.
- (3) Shut-off signal resets PLY and Fst Flip-Flops, therefore INHIBIT signal (INH, L603-3) will be set to H.

A base current of Q605 flows through INHIBIT signal H and Q605 turns to On and discharges the C611.

Therefore Q605, Q606 and Q608 turn to Off and shut-off signal will be released.

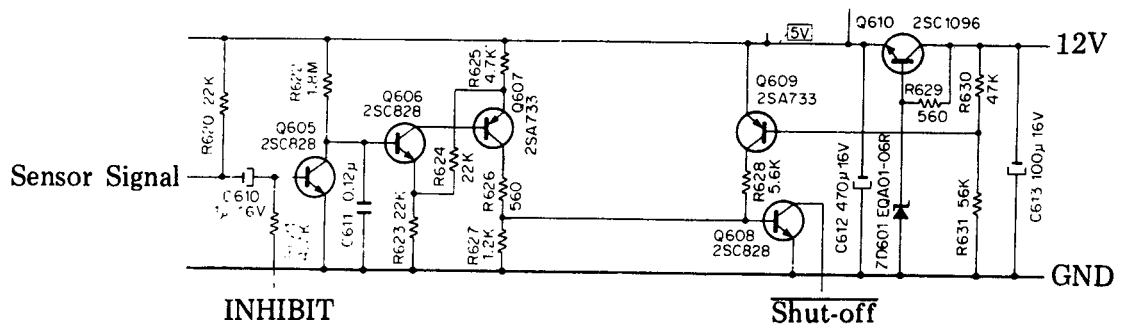
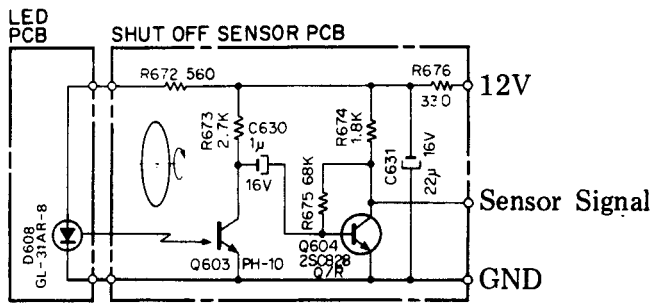

Fig. 2.26 Shut-off Sensor and Detector Circuit Diagram

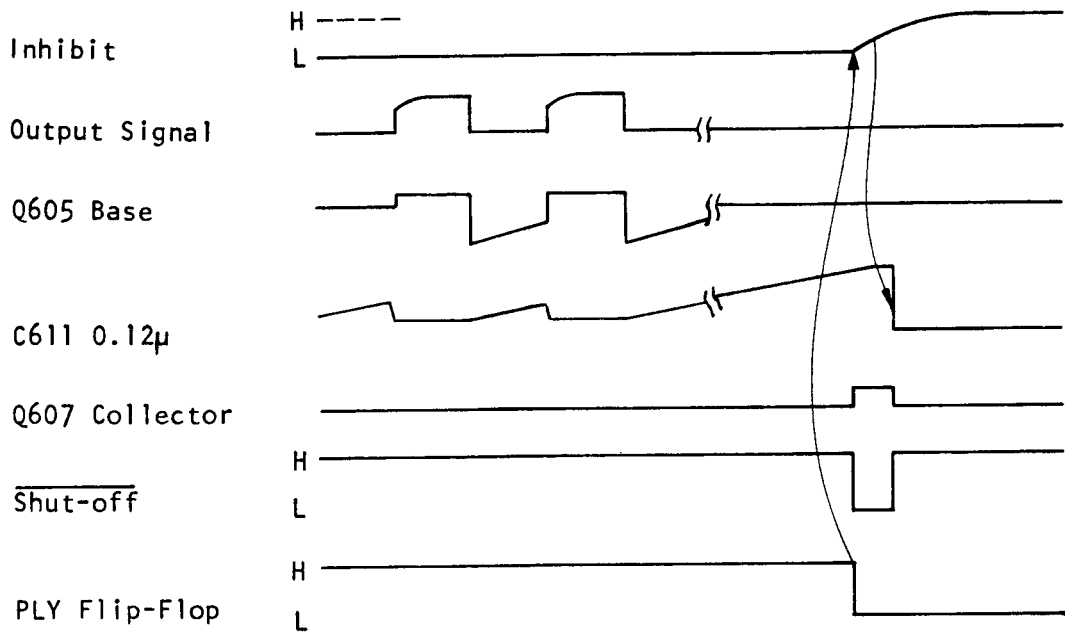

Fig. 2.27 Shut-off Timing Chart

2.3.3. AZIMUTH ALIGNMENT DETECTOR

Prior to recording, it is required that the azimuth alignment will be conducted for both sides A/B of a cassette tape to keep the optimum performance, with details being as follows:

Each cassette housing has a distortion for the molded pin locating between record and playback heads, therefore when tape is travelling through the molded pin the travelling of tape is slightly changed by each cassette housing.

And adjustment aims at an accurate azimuth alignment of the record and playback heads through a travelling tape.

Adjustment shall be conducted by turning the azimuth alignment screw while record mode and the adjustment panel test tone switch is On.

When the recorded 400Hz tape is played back, the difference of the phase between right and left channels indicates the difference of playback and record head azimuth.

Therefore when the difference of the phase equals to zero, playback and record head azimuth is aligned then both of the alignment beacon flickers alternately.

- (1) Left and right channel playback signals which are communicated to the operational amplifier terminals 5 and 9 will be amplified to the square waves.
- (2) These square waves are converted to the TTL IC voltage level through transistors Q601 and Q602, and communicated to the L607 TTL IC terminals T and D.
- (3) The outputs of L607 begin to repeat On and Off, and conduct to flicker LEDs alternately when same phase signals are conducted to T and D terminal.
- (4) Function of L607:
At transition of T terminal from L to H, D terminal H conducts output Q to H and \bar{Q} to L and also D terminal L conducts output Q to L and \bar{Q} to H.
- (5) SN7474N (Dual D-Type Edge-triggered Flip-Flop)

t_n	t_{n+1}	
Input D	Output Q	Output \bar{Q}
L	L	H
H	H	L

t_n : Bit time before clock pulse.
 t_{n+1} : Bit time after clock pulse.

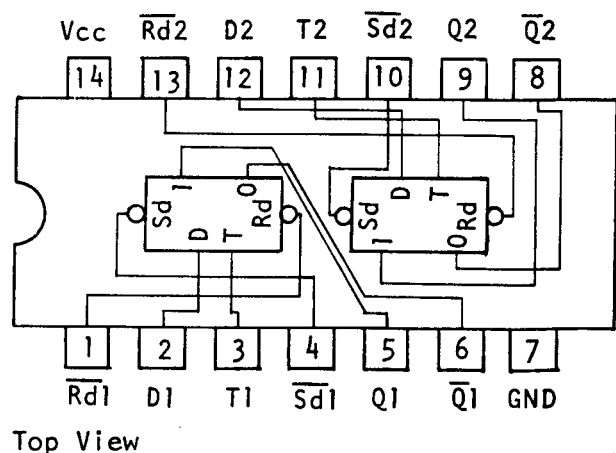

Compatible ICs

L607: N7474A, SN7474N, M53274P, HD2510, TD3474P

(6) RC4709 (Dual Operational Amplifier)

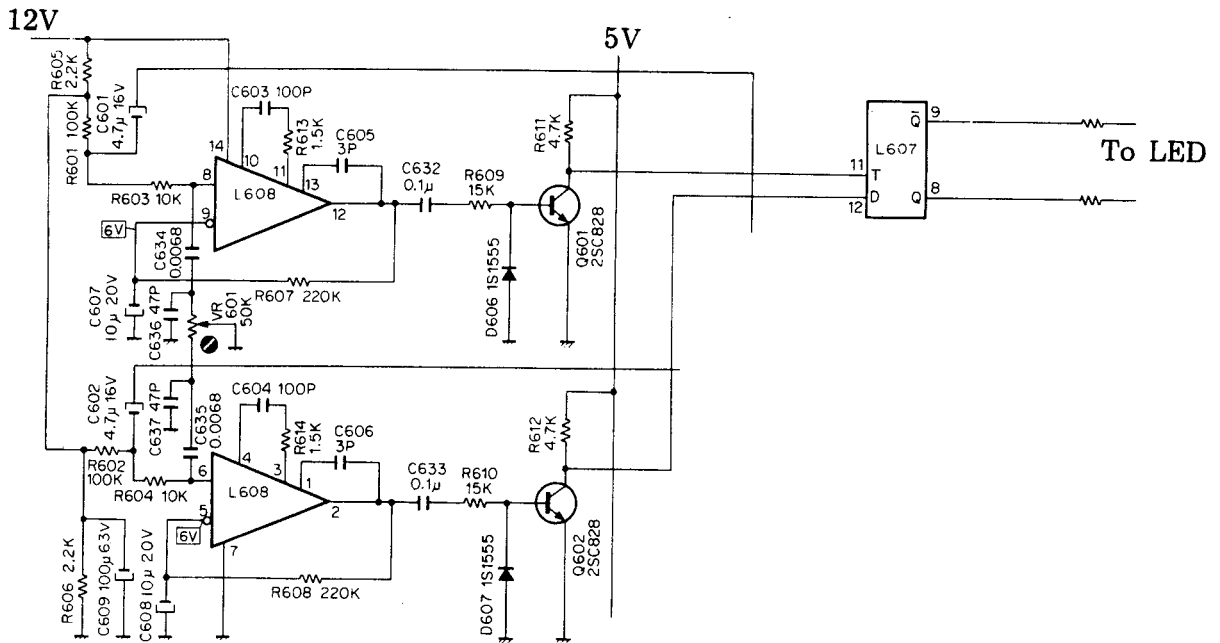
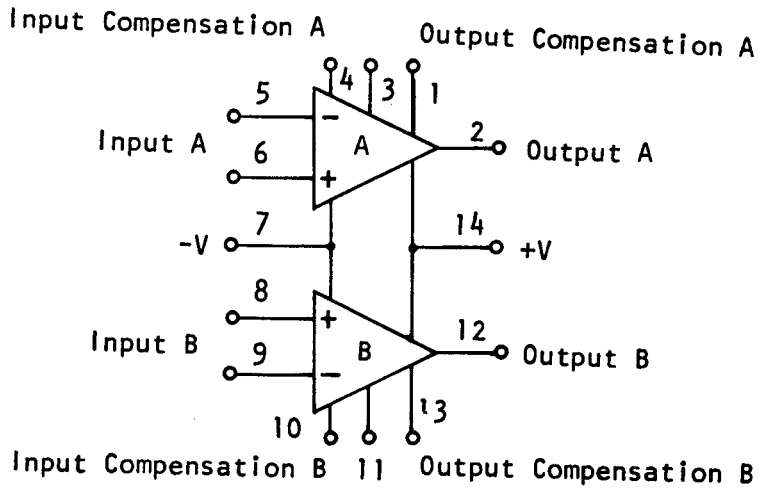
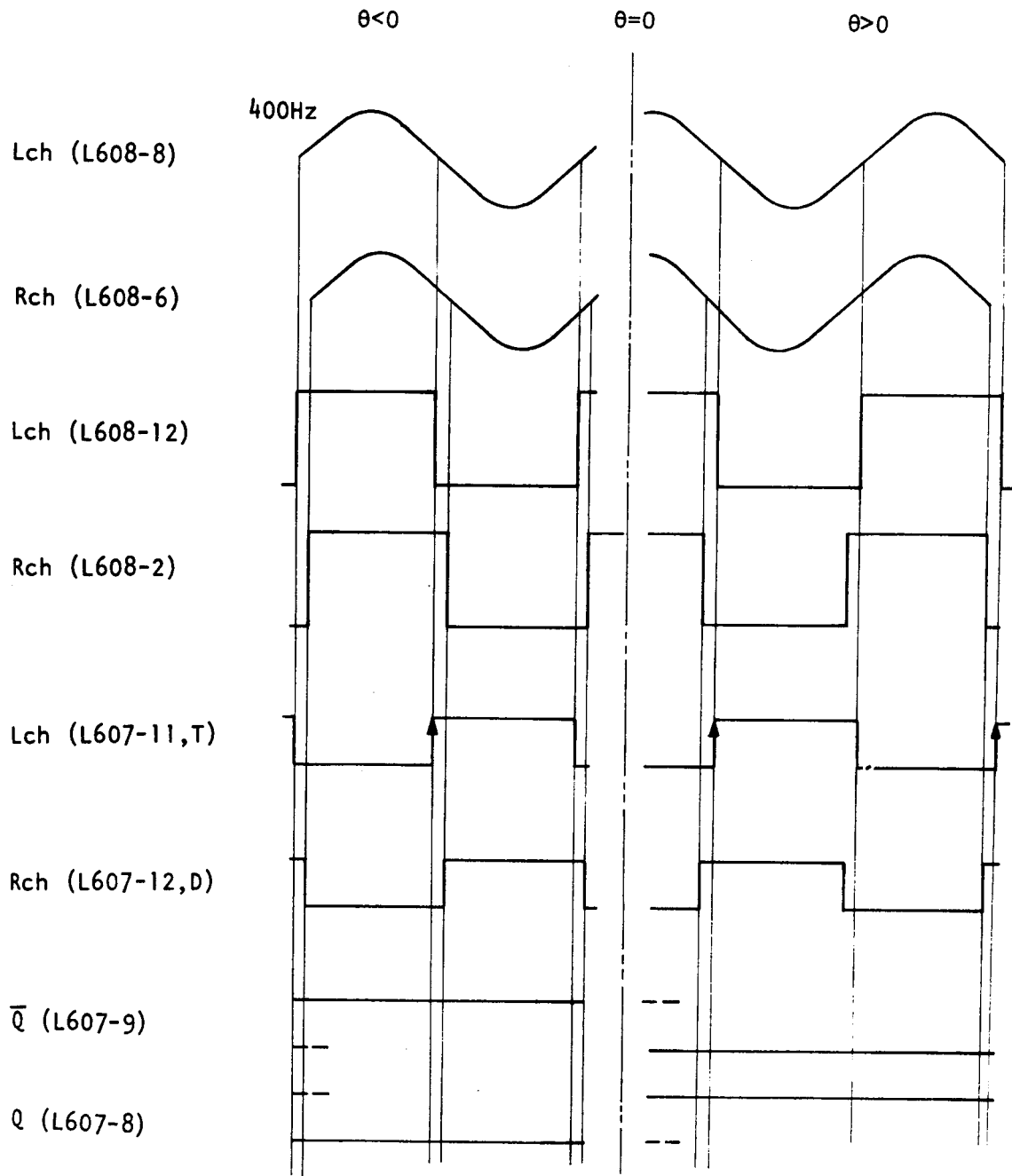

Fig. 2.28 Azimuth Alignment Circuit Diagram



Note: θ means a difference of phase between Lch and Rch playback signals.

Fig. 2.29 Azimuth Alignment Detector Timing Chart

2.3.4. MOTOR GOVERNOR

Motor governor connects to the Motor Assembly consisting of motor and sensor. Sensor consists of LED (Light Emitting Diode), photo transistor and slitted disc plate which is turned by motor.

When disc plate is turned, intermittent LED's lights are generated, while photo transistor receives these lights and outputs signals to the motor governor.

Sensor generates proportional frequency signals according to the motor speed. Motor governor controls the motor current in order to keep the constant sensor output signal i.e. constant motor speed.

- (1) Sensor output signals are amplified to the square waves by IC 501 1/2.
- (2) Through transistor Q501 differentiated pulses are generated by capacitor C506 (150PF).
- (3) C507 (3300PF) (IC501 2/2-6) is charged through resistor R511(150 K ohm) gradually. While the above operation, the positive differentiated pulse commands to discharge C507 quickly. Therefore charge and discharge are repeated according to the periodic time of sensor signal.
- (4) While, the voltage of IC 501 2/2-5 is fixed through pitch control volume.
When IC 501 2/2-6 is higher with respect to the 5 pin voltage, IC 501 2/2-7 output falls to ground and turns Q502 to On.
- (5) C509(1 micro F) will charge through Q503 and discharge through R516(10K ohm). A base current of Q504 flows through C509, then Q504, Q505 and Q506 amplifiers act to drive a motor.
- (6) Q503 turn On time gets short when periodic time of sensor output signal is shorted, and the voltage of C509 decrease, then motor speed decrease. When periodic sensor output signal becomes fast, the voltage of C509 and motor speed will increase.
Motor speed is therefore kept constant.
- (7) RC4558 (Dual Operational Amplifier)

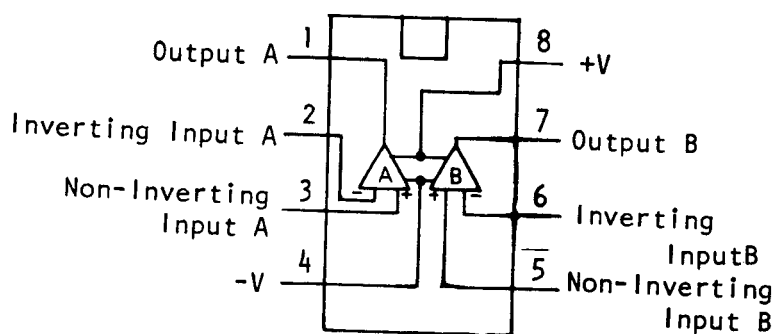

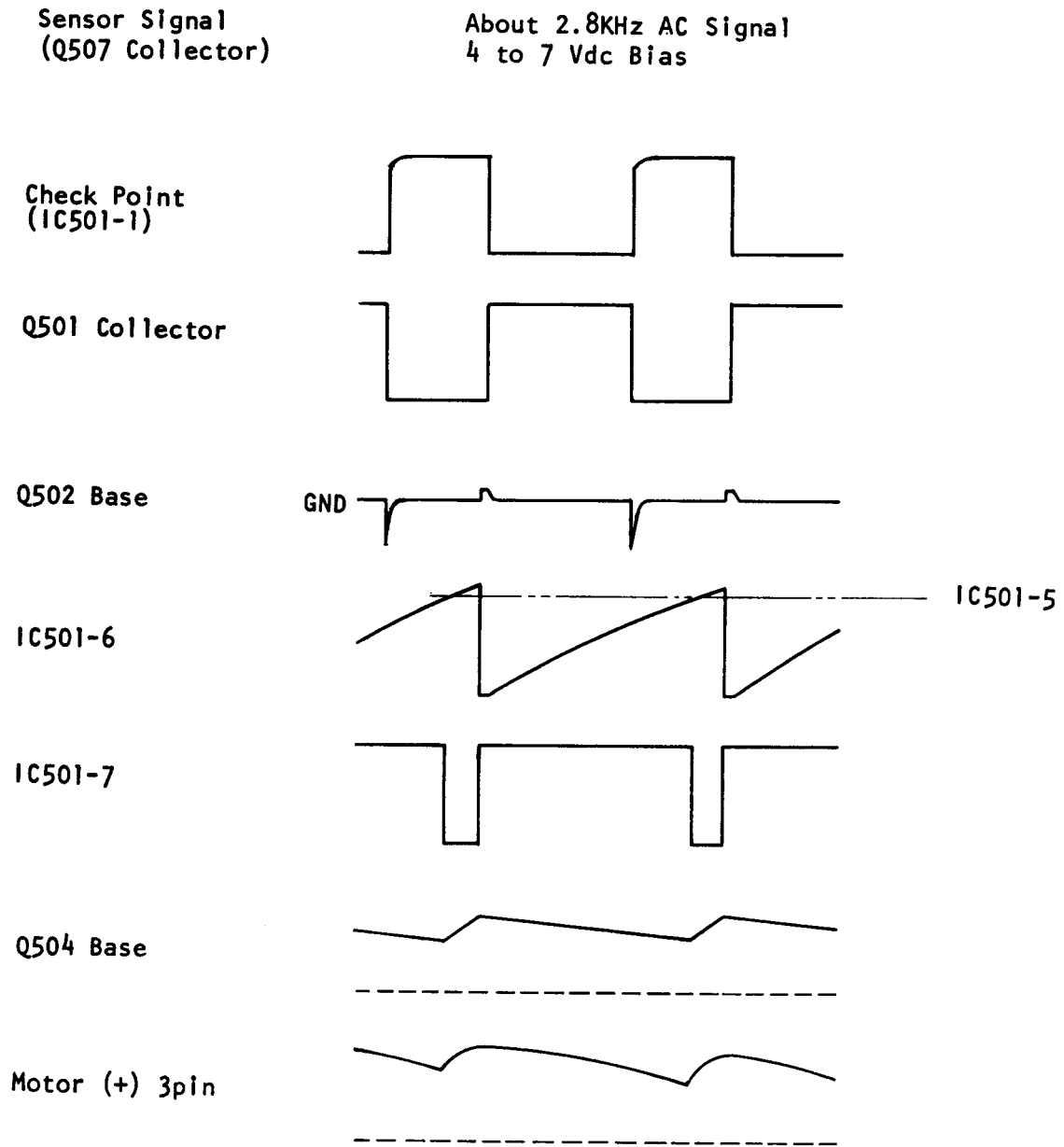

Fig. 2.30 Motor Governor Timing Chart

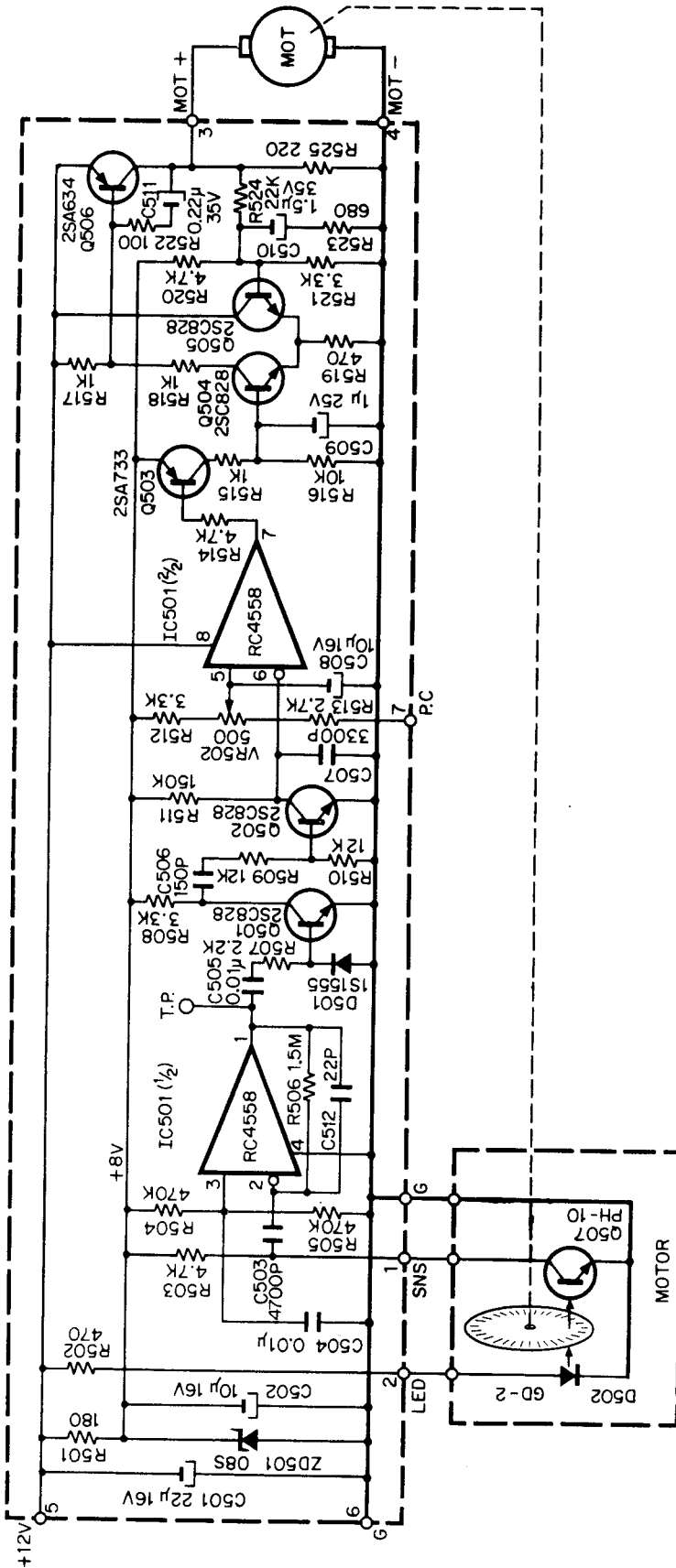

Fig. 2.31 Motor Governor Circuit Diagram

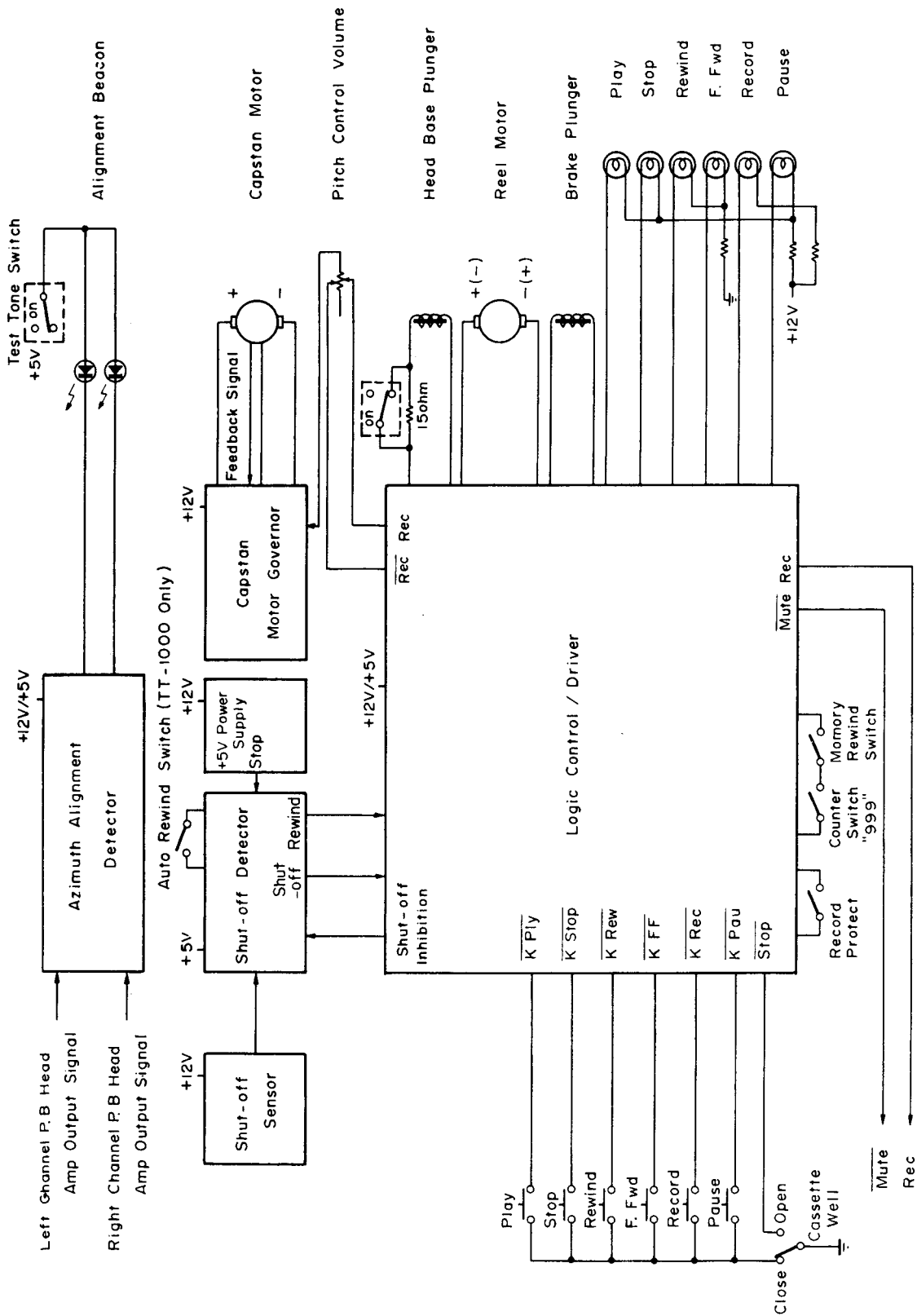

Fig. 2.24 Mechanism Control Overall Block Diagram

3. DISMANTLING

3.1. Front Panel Ass'y

Refer to the Fig. 10-1, unfasten and remove the parts according to the removal procedure from (F-01) to (F-12). And remove the cassette lid and cassette well as shown in the Fig. 3-1 (F-13, 14). Then unfasten screws and remove the front panel (F-15 to 17).

3.2. Head Mount Base Ass'y (Previous Type) and Pressure Roller Arm Ass'y

Refer to the Fig. 3-1 and remove cassette lid and cassette well (F-13, 14). Then refer to Fig. 10-4-1 and remove the head mount base ass'y (F-18 to 27). Unfasten E-ring and spring with care, and remove the pressure roller arm ass'y (F-28 to 31).

3.3. Head Mount Base E Ass'y (New Type) and Pressure Roller Arm Ass'y

Refer to the Fig. 3-1 and remove the cassette lid and cassette well (F-13, 14). Then refer to the Fig. 10-30 and remove the mount base cover ass'y (01 to 04, 05, 06, 08), then remove the pressure arm springs (09) and head mount base E ass'y (10 to 12). Refer to the Fig. 10-31 and unfasten E-ring and spring with care and remove the pressure roller arm ass'y (L01, 01, 02, 03).

3.4. Head Base Damper Ass'y and Eject Damper Bracket Ass'y

Refer to the Fig. 10-1 and remove the cabinet (F-01 to 07). Then remove the head base damper ass'y (F-32 to 34), and remove the eject damper bracket ass'y referring to the Fig. 10-21 (F-38 to 40).

3.5. Reel Drive Mechanism Ass'y

Refer to the Fig. 10-1 and remove the cabinet (F-01 to 07). Then refer to the Fig. 10-4-3 and remove the belt (F-41) from the main motor pulley, and also remove the belt from the main motor pulley and from the sub-motor pulley. And unfasten screws and remove the reel drive mechanism ass'y (F-42, 43).

3.6. Flywheel Ass'y

Refer to the Fig. 10-4-3 and remove the cabinet (F-01 to 07). Then refer to the Fig. 10-4-3 and remove the flywheel holder and belt and flywheels (F-44 to 47).

3.7. Control Button Ass'y A

Remove the front panel ass'y according to item 3.1. Then refer to the Fig. 10-1 and remove the control button ass'y (F-48 to 50).

3.8. Sub-Motor Ass'y

Remove the control button ass'y according to item 3.7. Refer to the Fig. 10-4-2 and remove the button holder (F-51, 52), then remove the auto shut-off ass'y (F-53, 54) referring to the Fig. 10-4-1. Refer to the Fig. 10-4-4 and remove the sub-motor ass'y (F-55, 56).

3.9. Main Motor Ass'y

Remove the control button ass'y according to item 3.7. Refer to the Fig. 10-4-2 and remove the button holder (F-51, 52), then remove the motor governor P.C.B. ass'y and main motor ass'y referring to the Fig. 10-4-4 (F-76, 77, 36, 78).

3.10. Transformer

Remove the front panel ass'y according to item 3.1. Then refer to the Fig. 10-2 and remove the rear panel and power supply ass'y (F-57 to 64) and disconnect the soldered wire of the power supply ass'y, and remove the transformer (F-65 to 69).

3.11. Main Board Ass'y

Refer to the wiring diagram. Remove the front panel ass'y according to item 3.1. Refer to the Fig. 10-2 and remove P.B. head amp. ass'y, P.B. Dolby NR ass'y and Rec. Dolby NR ass'y. Then disconnect the wire (Red- +17V, Black-GND). And unplug the 19P connectors, and disconnect the soldered signal wires (Blue-2 pcs., yellow-2 pcs.) which are connected to the MPX Sw.

3.12. Power Supply Ass'y

Remove the front panel ass'y according to item 3.1. And remove the power supply ass'y referring to the Fig. 10-2.

3.13. P.B. Head Amp Ass'y, P.B. Dolby NR Ass'y and Rec. Dolby NR Ass'y

Remove the front panel ass'y according to item 3.1., then remove each of the printed circuit boards referring to the Fig. 10-2 (F-60, 61).

3.14. Front Control Ass'y and Switch Board Ass'y

Remove the front panel ass'y according to item 3.1., and remove the power switch (F-79, 80), then remove the printed circuit boards referring to the Fig. 10-2 (F-81, 82).

3.15. 400Hz Osc. Sw. P.C.B. Ass'y

Remove the cassette lid and cassette well as shown in the Fig. 3-1. Refer to the Fig. 10-4-1 and remove adjustment plate (F-18 to 23), then remove the board referring to the Fig. 10-8 (F-83 to 86).

3.16. Shut-Off Luminous P.C.B. Ass'y and Shut-Off Sensor P.C.B. Ass'y

Refer to item 3.8 and remove the auto shut-off ass'y (F-54). Then refer to the Fig. 10-7, and remove the shut-off luminous P.C.B. ass'y (F-87 to 89) and shut-off sensor P.C.B. ass'y (F-90 to 93).

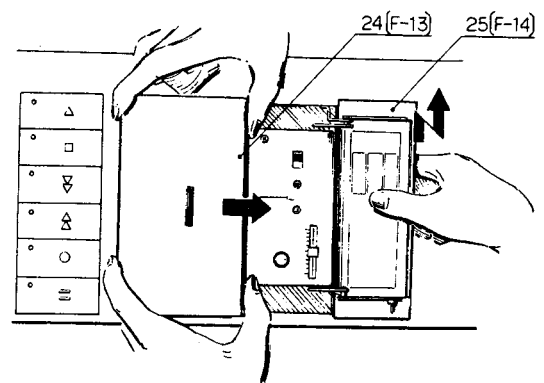

Fig. 3.1 Removal of Cassette Well and Lid

4. CHECK-OUT PROCEDURES

4.1. Check-Out Procedures for Inspection

4.1.1. Turn on the power switch.

- (1) Check to insure whether meter lamps, tape illumination lamp and stop lamp light, and whether the machine is held in stop mode.

4.1.2. Push the eject button.

- (1) Cassette lid will open automatically, then no control button operates.

4.1.3. Load a reference tape to check the following.

4.1.4. Depress the play button.

- (1) Play lamp turns to on and tape runs at a speed of 1-7/8 ips.
- (2) Auto shut-off function operates only a tape end so that machine is set to stop mode.
- (3) While tape is travelling check to insure whether stop, fast forward and rewind buttons operate.
When stop button is depressed, machine stops. When fast forward button is depressed, fast forward lamp turns to on and tape travelling is changed to fast forward winding mode. When rewind button is depressed, rewind lamp turns to on and tape travelling is changed to rewind mode.

4.1.5. Depress the fast forward button.

- (1) Fast forward lamp turns to on and tape runs at a speed of about 61 ips.
- (2) Auto shut-off function operates only at an end of tape so that machine is set to stop mode.
- (3) When play, rewind, or stop button is depressed, fast forward mode is changed to playback mode, rewind mode, or stop mode according to each button.

4.1.6. Depress the rewind button and set the memory switch to off.

- (1) Rewind lamp turns to on and tape runs at a speed of about 61 ips.
- (2) Auto shut-off function operates only at an end of tape so that machine is set to stop mode.
- (3) When play, fast forward, or stop button is depressed, rewind mode is changed to playback mode, fast forward mode, or stop mode according to each button.
- (4) For auto rewind check, turn on the memory switch and reset the tape counter to "000". After fast forward mode is set, set to the rewind mode and check to insure that the rewind mode changes to stop mode at counter "999".

4.1.7. Depress the pause button.

- (1) Pause button operates while playback and recording so that pause mode is set, and tape travelling is stopped by releasing head base solenoid drive. When playback or recording re-starts, mute function operates for about 1 second.
- (2) When pause button is depressed at stop mode, pause lamp turns on and stop lamp turns off. When pause button is depressed at fast forward or rewind mode, pause lamp illuminates only while button is depressed.

4.1.8. Depress the record button.

- (1) Except for break-out legs of the loaded cassette or without any loaded cassette, record mode operates only when record button is depressed at stop mode.
- (2) Depress the pause button while record mode is functioning. Record/pause mode will operate.
- (3) Depress the play button while record mode is functioning. Recording mode will operate.

4.1.9. Depress the stop button.

- (1) Check to insure whether playback, recording, fast forward and rewind modes are set to stop mode.

4.1.10. Monitor switch ON/OFF.

- (1) Check to insure whether monitor outputs can be selected from source to tape monitor by turning monitor switch on and off.

4.1.11. Limiter switch ON/OFF.

- (1) Check to prevent the distortion from sudden transient peaks at limiter switch on.

4.1.12. Dolby NR switch IN/OUT.

- (1) While playback, hiss noise will reduce at switch IN.

4.1.13. Tape selector switch NORMAL/CrO2.

- (1) While playback, check to insure whether tape selector switch is operating correctly.

4.1.14. Test tone switch ON/OFF.

- (1) Switch on the test tone switch and set the monitor switch to source, and check to insure that 400Hz test tone is generating by measuring level meters or headphone, etc.
- (2) Check to insure whether alignment beacon is illuminating at either one channel or both channels.

4.1.15. Listening test.

- (1) Connect music source to the input jacks and amplifier, speaker to the output jacks, and test the performance of playing back and recording/playing back.
Prior to recording, align the record head azimuth by azimuth alignment operation.
- (2) Check the wow/flutter, distortion, signal to noise ratio, erasure, etc.

4.2. Check Methods

4.2.1. Check on playback functions:

- (1) Check to insure whether the capstan, heads or pressure roller is free from dirt or dust.
- (2) Check on tape travel.
- (3) Load a 400Hz tape.
- (4) Set the machine in play mode.
- (5) Check the output of P.B. head amp. (both channels).
- (6) Check the output of P.B. Dolby NR (both channels).
- (7) Check the output of Line amp. (both channels).
- (8) Check the output jack (both channels).
- (9) Check headphone jack.

4.2.2. Check while recording:

Set each of input level controls to maximum, apply the rated input signal level to input jack and then check indications of the meters.

- (1) Check the Mic and DIN amp.
- (2) Check MPX functions.
- (3) Check Record Dolby NR.
- (4) Check Record Eq. amp.
- (5) Check the bias oscillator circuit.
- (6) Check record head.
- (7) Check erase head.

4.2.3. Check on Mechanisms:

- (1) Check the track positions of record head and playback head. (with Track Viewer DA09012A).
- (2) Check to insure whether the main motor rotates when the machine is set to On.
- (3) Push the play button, and check to insure whether the head base solenoid activates and whether the take-up reel rotates.
- (4) While in the (3) mode as above, check to insure whether auto shut-off returns the head base and the stop lamp illuminates when take-up reel is stopped by hand.
- (5) When the fast forward button is pushed, check to insure whether the FF lamp illuminates and whether the fast forward mode activates.

- (6) When the take-up reel is stopped by hand while in (5) mode as above, check to insure whether the auto shut-off activates to set the machine in stop mode.
- (7) Push the rewind button and check to insure whether the rewind lamp illuminates, fast wind motor rotates, auto shut-off activated, and whether stop lamp lights.
- (8) Load a blank cassette tape.
- (9) Check to insure whether the unit is free from any abnormality while in fast forward and rewind mode.
- (10) Push the record and pause buttons simultaneously, and check to insure whether record is paused.
- (11) Push the play button while in (1) state, and check to insure whether tape starts travelling and recording commences.
- (12) Push stop button and check to insure whether the machine is set to stop from any of the modes.
- (13) Measure the torque of take-up, fast forward and rewind (with torque gauge (DA09013A)).
- (14) Check the tape speed and wow/flutter (with 3KHz Speed & Wow/Flutter tape (DA09006A)).
- (15) Check the playback head height and tape travel (with 1KHz Track Alignment tape (DA09007A) and Tape Travelling Cassette (DA09011A)).

4.2.4. Overall check:

- (1) Check the frequency response (bias adjustment).
- (2) Check distortion.
- (3) Check signal to noise ratio.
- (4) Check channel separation.
- (5) Check crosstalk.
- (6) Check erasure.

5. MEASUREMENT AND MAINTENANCE INSTRUMENTS

5.1. Measurement Instrument and Connection

Refer to Fig. 5.1 Measurement Connection.

- (1) Audio Generator (20Hz – 200KHz)
- (2) AC Millivolt Meter (with dB measures)
- (3) Oscilloscope (DC – 5 MHz)
- (4) Distortion Meter
- (5) Speed & Wow/Flutter Meter
- (6) Frequency Counter (DC – 1MHz)
- (7) Ohm Meter
- (8) DC Volt Meter (0 – 30V)
- (9) AC Volt Meter (0 – 400V)
- (10) Audio Evaluator 2001 (NP01005)
(Including the Distortion, Oscillator and dB meter)
- (11) Tape Travelling Cassette (DA09011A)
- (12) Track Viewer (DA09012A)
- (13) Torque Gauge (DA09013A)
- (14) 15KHz Azimuth Tape (DA09004A)
- (15) 3KHz Speed & Wow/Flutter Tape (DA09006A)
- (16) 1KHz Track Alignment Tape (DA09007A)
- (17) 400Hz Level Tape (DA09005A)
- (18) 20KHz PB Frequency Response Tape (DA09001A)
- (19) 15KHz PB Frequency Response Tape (DA09002A)
- (20) 10KHz PB Frequency Response Tape (DA09003A)
- (21) Reference Normal Tape (DA09008A)
- (22) Reference EX Tape (DA09010A)
- (23) Reference CrO₂ Tape (DA09009A)
- (24) Liquid for Tape Magnetized Development (MAGNA-SEE, a product of SOUNDCRAFT, or equivalent).

Note: Items (10) to (23) show the products of NAKAMICHI RESEARCH INC.

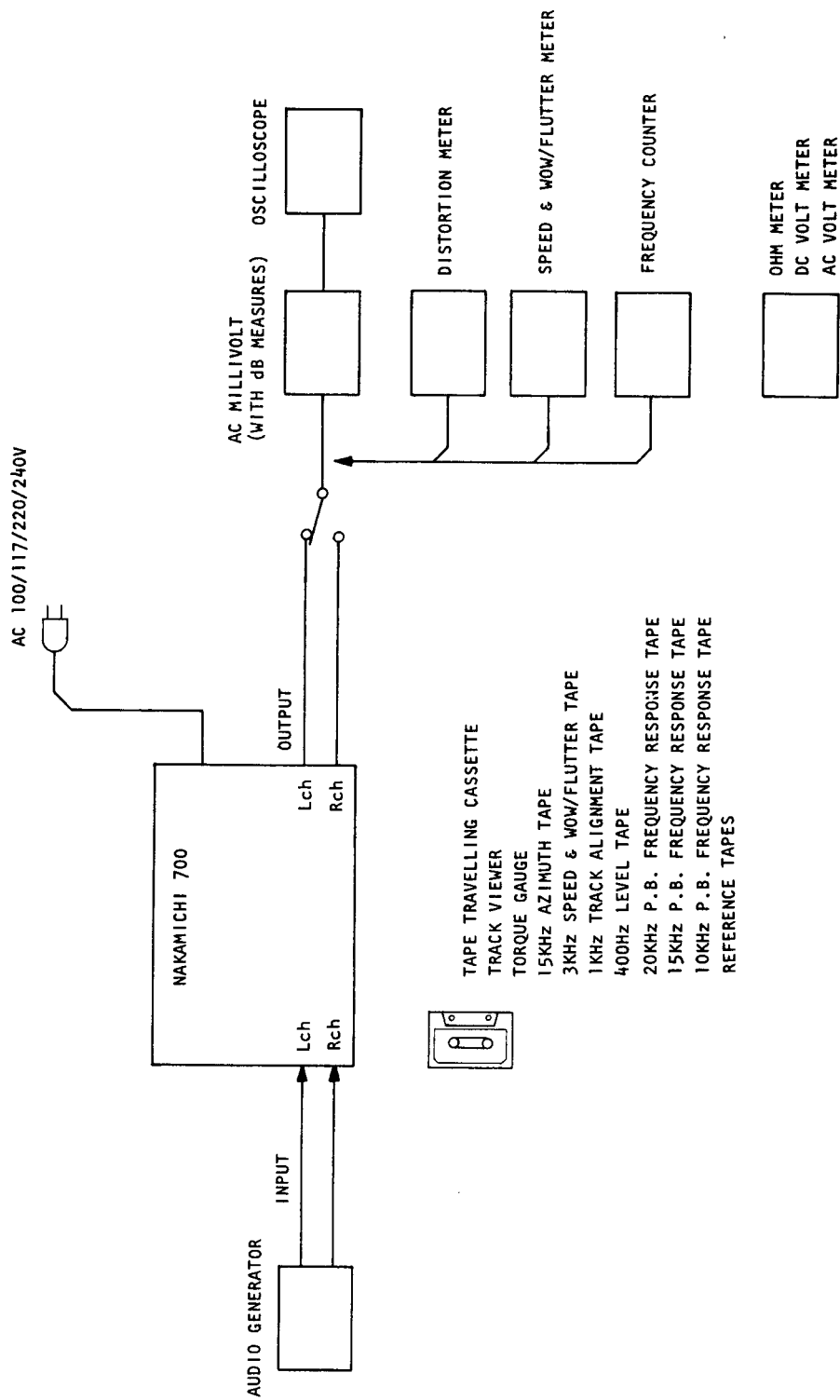

Note: When a check is made on Amp. etc. by means of an extension cord, re-adjustment shall be made without fail (after final installation to the model chassis). The check without removal of an extension cord will cause inaccurate adjustments.

Fig. 5.1 Measurement Connection

5.2. Maintenance Instruments

Refer to Fig. 5.2 Extension Cord Connection.

- (1) Extension cord (19P-D) (DA09019A)
- (2) Extension cord (14P-PB) (DA09015A)
- (3) Extension cord (19P) (DA09014A) - 2 pcs.
- (4) Extension cord (14P) (DA09016A)

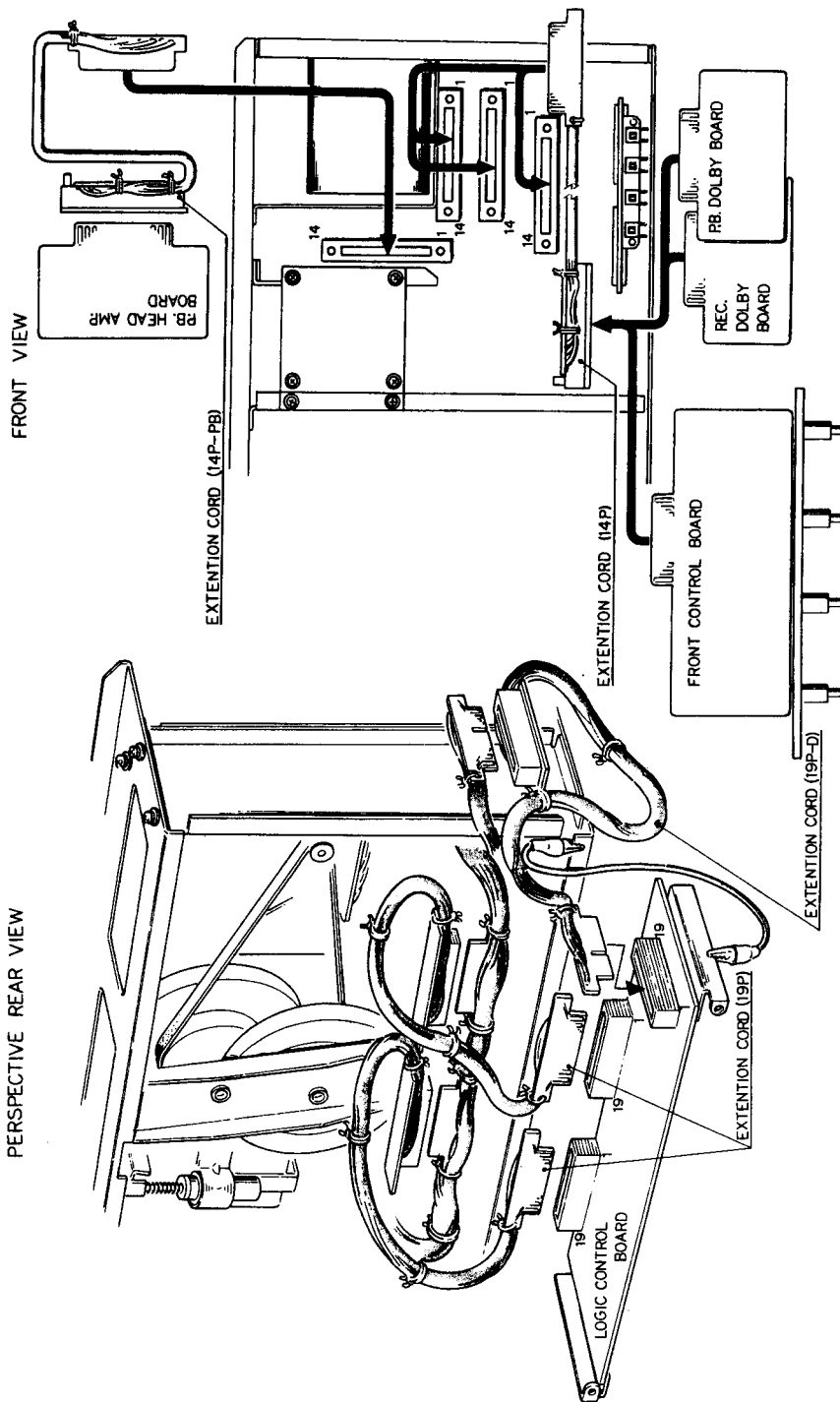

Note: Connect a cord between chassis and Logic P.C.B. as shown in the figure.

Fig. 5.2 Extension Cord Connection

6. MECHANICAL MEASUREMENTS AND ADJUSTMENTS

6.1. Take-up, Fast Forward and Rewind Torque Adjustment

6.1.1. Take-up Torque Adjustment

- (1) Refer to Fig. 10.4.3 Mechanism Ass'y and Fig. 10.16 Take-up Pulley Ass'y.
- (2) Take-up Torque should be 40 ± 10 g-cm.
- (3) To adjust torque, move take-up spring as shown in Fig. 6.1.
- (4) If torque is not sufficient during play mode, bend the take-up spring equally or replace the take-up spring.

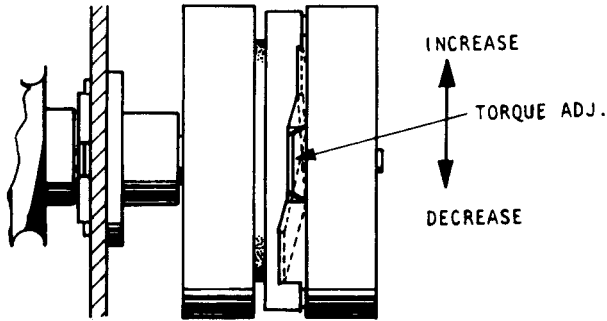

Fig. 6.1

6.1.2. Fast Forward and Rewind Torque Adjustment

- (1) Refer to Fig. 10.4.3 Mechanism Ass'y and Fig. 10.10 Reel Drive Mechanism Ass'y.
- (2) Fast Forward and Rewind Torque should not be less than 50g-cm.
- (3) Adjust the friction torque by adjusting location of motor friction pipe. Refer to the Fig. 6.2.
Friction Torque=40g-cm (typical)
Note: Insure whether the motor is rotating when both of the supply and take-up reel hubs are stopped by hand, depressing the FF or REW BUTTON.
- (4) Adjust the location of the Reel Drive Mechanism Ass'y to obtain the rated drive being free from abnormal movement.

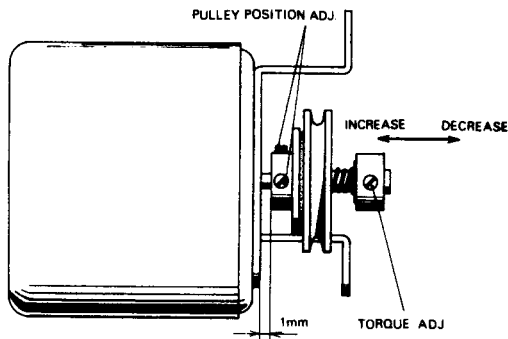

Fig. 6.2

6.2. Headblock

Following explain the two kinds of headblock, one is of previous type before serial No. 3709322 and the other is head height adjustable new type after serial No. 3709323.

6.2.1. Head Replacement Procedures

(1) Previous Type

Refer to Fig. 10.4.1, 10.6, 10.28 and 10.29. Remove the head mount base ass'y, referring to "3.2. Head Mount Base Ass'y (Previous Type) and Pressure Roller Arm Ass'y". Remove the playback and record heads from head mount base by loosening fastened screws, and remove the erase head from pressure roller arm ass'y.

(2) New Type

Refer to Fig. 10.30, 10.31, 10.33 and 10.34. Remove the head mount base ass'y referring to "3.3. Head Mount Base E Ass'y (New Type) and Pressure Roller Arm Ass'y".

Refer to Fig. 10.31 and unfasten screws and springs (12, 11) then remove record and playback heads ass'y (05, 06) with care not to lose washers and steel balls (L04, 08). Refer to Fig. 10.33 and 10.34, unfasten screws and remove the record and playback heads.

(3) Replace each head referring to Fig. 12.1 Amplifier Wiring Diagram.

Note 1: Fasten screws of playback and record heads, insuring to keep correct direction, vertical against to the cassette tape.

Note 2: Fasten a screw fixing a erase head to the pressure roller arm ass'y chassis without any dust, and pushing erase head toward the pressure roller insuring to keep more than 0.1mm space. Then apply a drip of lock tight paint to the screw. Check to insure signal wires are not in contact with the chassis.

Note 3: Separation of signal wires between record and playback heads will be required for avoiding bias leakage or crossfeed caused by interference.

Note 4: When replacing the heads be careful not to contaminate the head surface with dust or any other foreign materials; otherwise, the head installation angle may deviate, resulting in irregular tape travelling. Handle the heads with care not to give damages to the surface.

(4) After replacement of each head, the following adjustments are required.

Mechanical Adjustment ... Items from 6.2.2. to 6.2.6.

Electrical Adjustment:

Playback Head	7.6. Playback Level Calibration
	7.7. Playback Frequency Response
	7.8. Head Azimuth Alignment (Playback Head)
	7.13. Record Bias and Record/Playback Level
Record Head	7.11. Recording Equalization Peaking
	7.13. Record Bias and Record/Playback Level
Erase Head	7.9. Bias Oscillator Frequency

6.2.2. Head Height Adjustment (Previous Type)

Refer to Fig. 6.3.

- (1) Load the Track Viewer (DA09012A) and check the positions of playback and record heads. While adjustment, check to insure that the L-R center of each head coincides in position with the middle point between two lines (0.3mm distance) on the Track Viewer.

- (2) If the L-R center deviates from the middle point, correct the deviation using an appropriate PH and RH spacers to be provided for the playback and record heads. Fig. 10.29 P.B. Head Ass'y and Fig. 10.28 Rec. Head Ass'y show how to fix the spacers as shown in the Fig. 6.4 and 6.5. (C and D are the screw for the playback and record head azimuth alignments).

6.2.3. Head Height Adjustment (New Type)

Refer to Fig. 6.6.

- (1) Load the Track Viewer (DA09012A) and check the positions of playback and record heads. While adjustment, check to insure that the L-R center of each head coincides in position with the middle point between two lines (0.3mm distance) on the Track Viewer.
- (2) If the L-R center deviates from the middle point, correct the deviation by adjusting screws E and F to be adjusted for the playback and record heads. (C and D are the screws for the playback and record head azimuth alignments.)

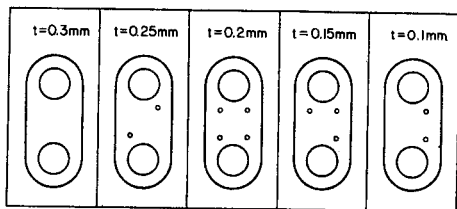

Fig. 6.4

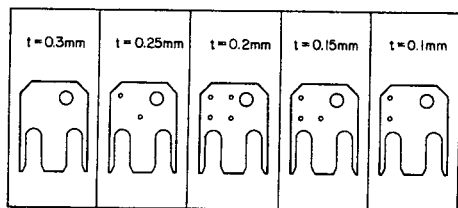

Fig. 6.5

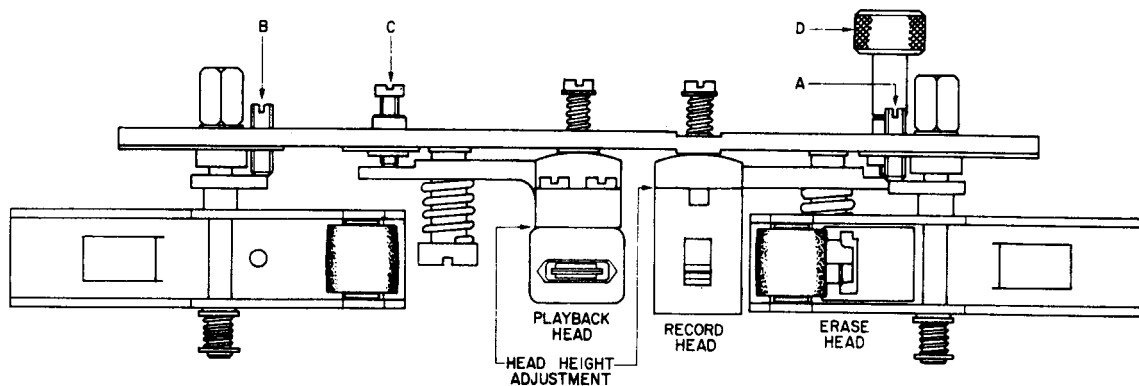

Fig. 6.3

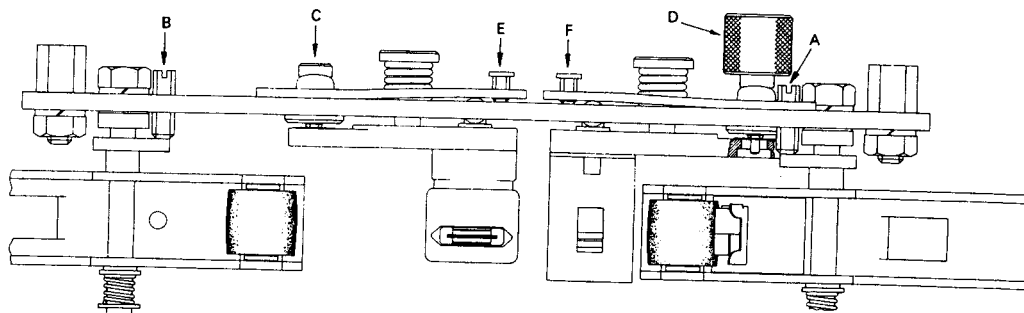

Fig. 6.6

6.2.4. Playback Head Adjustment (Previous Type and New Type)

- (1) Load the Track Alignment Tape (DA09007A) and check the head height on the cassette tape deck. Set the MONITOR SW to Tape and play the tape back. Adjust the tape height adjusting screw A until each level meter of both channels reads the minimum value.
- (2) Load the Tape Travelling Cassette (DA09011A) and set to the playback mode. Check to insure that the tape height while running is within $\pm 0.3\text{mm}$ at any tape position when measured from the center of a cassette housing.

Note: Observing tape travelling on the playback head, check the following points:

- a. Tape travelling does not wave.
- b. At a tape starting point, the tolerance of tape travelling fluctuation is within about $\pm 0.3\text{mm}$.

If not, adjust the pressure roller height by adjusting screw B located at the take-up reel side. After the tape travel is corrected, check to insure that the pressure roller position is within $\pm 1\text{mm}$ when measured from the center of a cassette housing. Note that in most cases of playback head adjustment turning of the screw B will not be required for misalignment. If tape travel cannot still be adjusted, refer to "6.4. Tape Travelling Adjustment".

- (3) When adjustments are completed, proceed again as directed in the Steps (1) and (2).

- (4) Load a 15kHz Azimuth Tape (DA09004A) for adjusting the P.B. head azimuth. Set the MONITOR SW to the TAPE position and playback. Adjust the P.B. head azimuth alignment screw C until each level meter of both channels reads the maximum value.

After completion of the adjustment in this step, check the head height as directed in Step (1).

- (5) Apply a drip of lock tight paint to the screws A and B.

X

6.2.5. Record Head Adjustment (Previous Type and New Type)

This adjustment should not be performed unless the playback head adjustment directed in the preceding section is completed.

- (1) Load a blank tape, Reference CrO₂ (DA09009A). Set the TEST TONE SW to the ON position, the TAPE SELECTOR SW to the CrO₂ position, and the MONITOR SW to the Tape position. Set to Record mode and adjust record head azimuth alignment screw D until the alignment beacon started flickering alternately. Record the same portion of the both A and B sides of the tape.
- (2) Immerse the recorded tape into a magnetized developing solution. In turn, check to insure that the recording head tracks across the center are separated by space of 0.4 to 0.6mm typically 0.5mm as illustrated in Fig. 6.7. If not readjustments from item 6.2.2. will be required.

Note: Liquid for Tape Magnetized Development: "MAGNA-SEE, SOUNDCRAFT a product of CBS RECORDS a division of Columbia Broadcasting System, Inc., Danbury, Conn. 06810, or equivalent". After development, clean the tape otherwise pressure roller will become dirty.

The above development will not be required if the difference of playback and record head heights are within 0.1mm at "6.2.2. and 6.2.3. Head Height Adjustment".

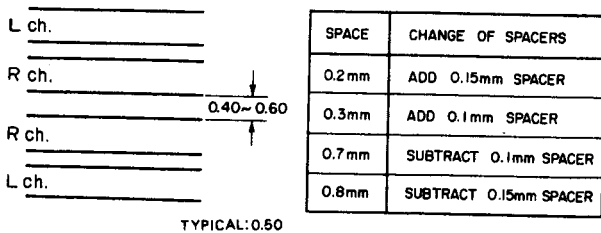

Fig. 6.7

6.2.6. Erase Head Adjustment (Previous Type and New Type)

After removal of erase head, refer to the "6.2.1. Head Replacement Procedures".

6.3. Flywheel Adjutment

When mounting the flywheel holder, adjust the flywheel clearances should be 0.05 to 0.1mm.

Caution: When installing the flywheel, be sure to clean oil off with an alcohol-dipped cloth from capstan which will be in contact with pressure roller.

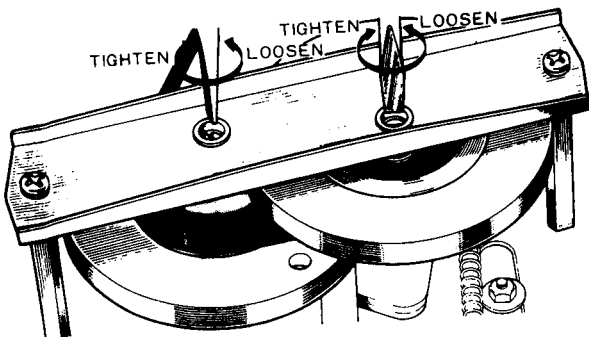

Fig. 6.8

6.4. Tape Travelling Adjustment

Inaccurate tape travelling extremely deteriorates the performance of tape decks therefore careful checks are required.

6.4.1. Check-out Method

- (1) Check to insure whether the head height is correct.
- (2) Load a tape travelling cassette (DA090011A) and play it and check to insure freedom from waving, looseness, etc.
- (3) The difference of head height between supply side and take-up side shall not be more than 0.3mm.
- (4) After more than 2 seconds when depressed play button, the tolerance of the tape on the playback head shall not be more than 0.05mm.
- (5) Feed in the test tone signals to the Nakamichi reference CrO₂ tape (DA09009A) and record and play it back, when the level change shall not be more than 1dB.

6.4.2. Adjustment

- (1) Check to insure whether any of the heads is not in contact with the cassette housing.
- (2) Check to insure whether the pressure roller is located in parallel with the capstan shaft (Also check to insure whether the heads are free from dust or dirt, and whether the pressure roller arm is free from bending).
- (3) Check to insure whether the surface of the pressure roller is globular not straight. Other than the above that is straight type, concaved, or oiled surface shall be subject to replacement.

- (4) The pressure of the pressure roller shall be 400g±50g.

- (5) Adjustment of Pressure Roller Timing.

a. Refer to Fig. 6.9.

Push down the head base by hand while in stop mode till the take-up pressure roller reaches the capstan, and then check to insure whether the gap between the supply pressure roller and the capstan is 0.5mm.

b. While in play mode, check to insure whether the gap between the take-up pressure roller arm and the stopper is 1.25mm, and whether that between the supply pressure roller arm and stopper is 0.75mm.

Note: If the foregoing requirements are not satisfied, adjustment shall be made by bending the stopper.

- (6) The clearance between the capstan shaft and thrust shall be 0.1 – 0.05 mm.

- (7) The tape guide on which if any scratches, etc. are noted shall be replaced. Check shall also be made to insure whether the erase head surface is smooth.

- (8) The use of defective head base damper will deteriorate the tape travel at the beginning of activation.

- (9) The parallelism between both of the capstan axis is one of the most important factors for an accurate operation. If great shock is given to the capstan, the capstan flange ass'y shall be replaced.

Note: The cassette house shall also be checked to insure freedom from deformation, bending, etc.

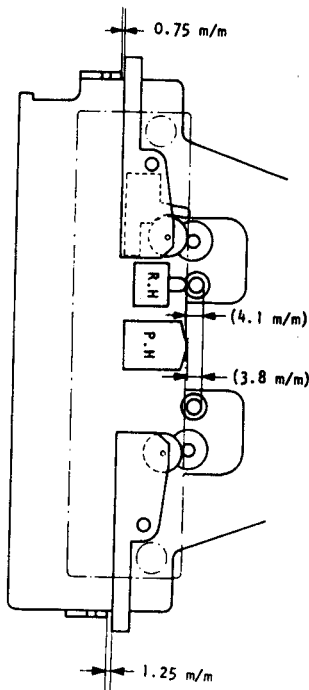

Fig. 6.9

6.5. Adjustment of Reel Drive Mechanism Ass'y

- (1) Check the take-up torque (40g-cm±10g-cm) (with the torque gauge).
- (2) Check shall be made on rewind and fast forward torque (not less than 50g-cm).
- (3) Measure the time length while rewinding and fast forwarding.
 Note 1: Where rewinding and fast forwarding exceeds 60 seconds, replace the reel drive friction.
 Note 2: If chattering is appreciable, replace the reel drive mechanism ass'y.
 Note 3: Where the take-up torque should be too weak, adjust the spring pressure of the reel hub spring.

6.6. Damper Adjustment

6.6.1. Head Base Damper

- (1) Slowly turn the exhaust adjusting screw clockwise repeatedly depressing and releasing the damper piston by hand. Set the screw at such an initial position that the piston cannot be depressed into the inmost end by the decreased damper pressure.
- (2) Return the screw approximately 90 degrees counterclockwise from the set position given in Step (1) above. Check to insure whether the head base is smoothly locked by repeatedly playing back and stopping the tape feed mechanism. If the double motion or associated shock is too strong, further precise adjustment is required.
 Note: Do not tighten the exhaust adjusting screw excessively as it may be damaged.

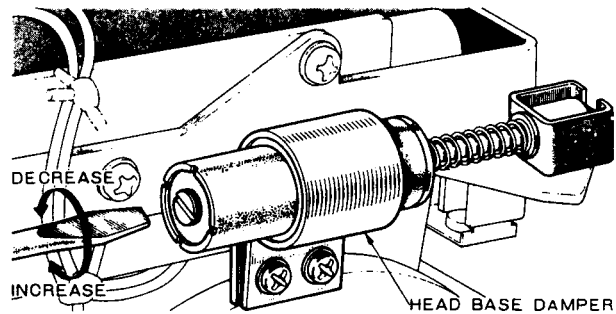

Fig. 6.10

6.6.2. Eject Damper

Install the cassette compartment lid. Adjust the exhaust adjusting screw at the eject damper Ass'y until it takes 0.5 to 1.0 second to stop the lid eject movement after the eject push button is depressed.

Note: Do not tighten the exhaust adjusting screw excessively as it may be damaged.

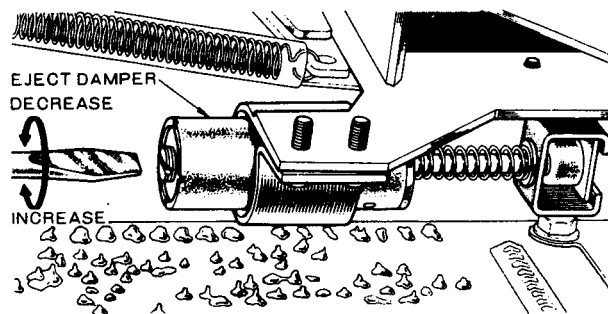

Fig. 6.11

6.7. Lubrication

Place the deck in a horizontal position and then remove the cassette lid.

Apply a few drops of oil (LAUNA NO. 40) into the oil cap hole of the capstan flange every 500 hours of use.

Note: If the lubricating oil is applied also to the capstan shaft and other drive mechanisms, clean it off with an alcohol-dipped cloth.

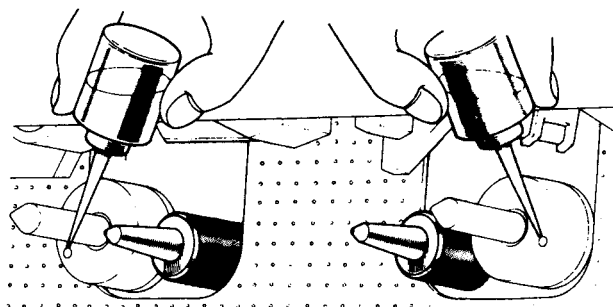

Fig. 6.12

7. ELECTRICAL MEASUREMENTS AND ADJUSTMENTS

Mechanical adjustments have to be performed prior to this adjustment. Refer to the "8. Parts Location for Electrical Adjustment, Fig. 8-1, Fig. 8-2" for the positions of semi-fixed volume and test point.

7.1. Tape Speed

Signal Source

3kHz Speed Wow Flutter Tape (DA09006A)

Measurement Connection

Frequency Counter to Output Jacks

Mode

CONTROL BUTTON – Playback
 MONITOR SW – Tape
 TAPE SELECTOR SW – Cr₂

Adjustment

- (1) Set the Pitch Control Knob to "0" position.
 - (2) Adjust the Speed Control VR502 to obtain 3kHz on Frequency Counter.
- VR502 – Motor Governor P.C.B.

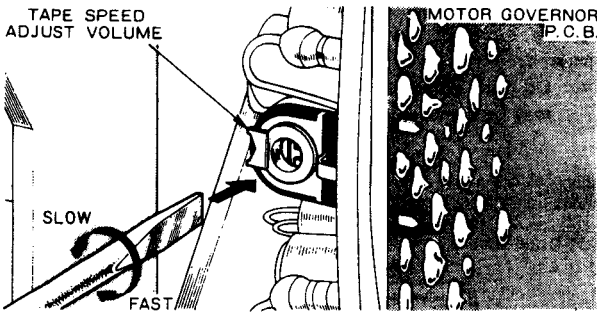

Fig. 7.1

7.2. Meter Level Calibration

Signal Source

1kHz 0.3V to Input Jacks or 1kHz 0.1V to DIN Input.

Measurement Connection

VTVM to Test Point TP1 (Main P.C.B.) - GND (Lch),
 TP2 (Main P.C.B.) - GND (Rch).

Mode

MONITOR SW-SOURCE

Adjustment

- (1) Adjust the line input level controls to obtain 100mV±2mV on VTVM.
- (2) Adjust the Meter Calibration VR155, 255 to obtain 0 dB on Level Meters.

VR155 (Lch), VR255 (Rch) – Main P.C.B.

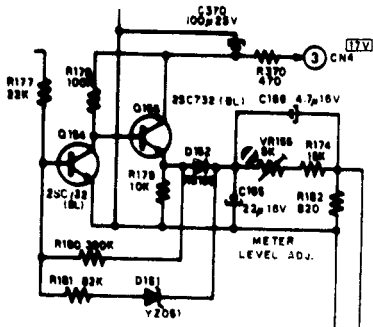

Fig. 7.2

7.3. 400Hz Test Tone

Mode

MONITOR SW - SOURCE
 400Hz TEST TONE SW - ON

Adjustment

Adjust the Tone Calibration VR351 so that the level meter of the L channel indicate 0 dB.

VR351 –Main P.C.B.

Note: If the level meters of the L and R channels are not balanced, modification of R175 or R275 will be required.

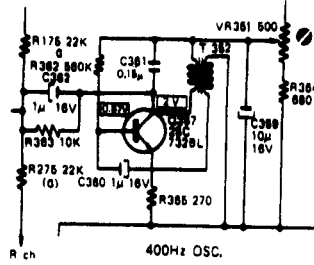

Fig. 7.3

7.4. 19KHz MPX Filter

Signal Source

19kHz 0.3V to Input Jacks or 0.1V to DIN Input.

Measurement Connection

VTVM and Frequency Counter to Output Jacks or DIN Output.

MODE

MONITOR SW - SOURCE
 MPX SW - OFF
 DOLBY NR SW - OUT

Adjustment

- (1) Adjust the line input level controls to obtain 0 dB (1V) on the Level Meters and VTVM.
- (2) Set the MPX SW to ON.
- (3) Adjust MPX Filter Coils L154, 254 to obtain the minimum reading on VTVM.

L154 (L ch), L254 (R ch) – Main P.C.B.

Note: Frequency has to be 19kHz±100Hz on Frequency Counter.

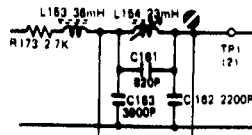

Fig. 7.4

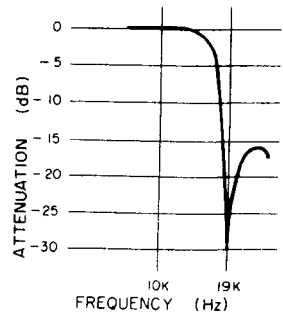

Fig. 7.5

7.5. Limiter Level

Signal Source

1kHz 0.3V to Input Jacks or 1kHz 0.1V to DIN Input.

Measurement Connection

VTVM to Output Jacks or DIN Output.

Mode

MONITOR SW - SOURCE
LIMITER SW - OFF

Adjustment

- (1) Adjust the line input level controls to obtain 0 dB on Level Meters.
- (2) Adjust the line output level controls to obtain 0 dB (1V) on VTVM.
- (3) Adjust the line input level controls to obtain +4 dB on VTVM.
- (4) Set LIMITER SW to ON.
- (5) Adjust the Limiter level ADJ. VR703, 803 to obtain +3 dB on VTVM (so that +4 dB will be decreased by 1 dB)
VR703 (L ch), VR803 (R ch) - Front control P.C.B.

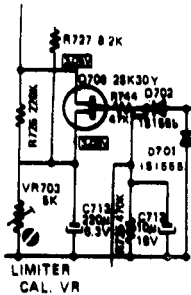

Fig. 7.6

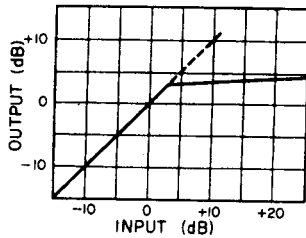

Fig. 7.7

7.6. Playback Level Calibration

Signal Source

400Hz P.B. Reference Tape (DA09005A)

Mode

CONTROL BUTTON - Playback
MONITOR SW - TAPE
TAPE SELECTOR SW - CrO₂

Adjustment

Adjust the Playback AMP. VR101, 201 so that the level meters indicate 0 dB.

VR101 (L ch), VR201 (R ch) - P.B. Head Amp. P.C.B.

Note: "7.2. Meter Level Calibration" to be completed prior to 7.6. as above.

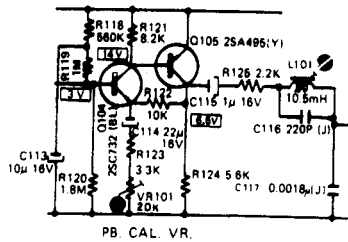

Fig. 7.8

7.7. Playback Frequency Response

Measurement Connection

VTVM to Output Jacks or DIN Output.

Mode

MONITOR SW - TAPE
TAPE SELECTOR SW - CrO₂
LIMITER SW - OFF
DOLBY NR SW - OUT

Adjustment

- (1) Load a 400Hz P.B. Reference Tape (DA09005A) and play it back.
Adjust the line output level controls to a certain level (example 0 dB).
- (2) Load a 10kHz P.B. Frequency Tape (DA09003A), 15kHz P.B. Frequency Tape (DA09002A) and 20kHz P.B. Frequency Tape (DA09001A), and adjust the Playback Head azimuth to give the maximum levels on VTVM with each Tape.
Check to insure level would be within -20 dB ± 3 dB against 400Hz P.B. Reference Tape.
- (3) If above level cannot be satisfied.
Refer to "7.22.1. Adjustment of Playback Frequency Response".
- (4) Load a 15kHz Azimuth Tape (DA09004A).
Adjust the playback head azimuth to give the maximum levels on VTVM.

7.8. Head Azimuth Alignment (Playback Head)

Signal Source

15kHz Azimuth Tape (DA09004A)

Measurement Connection

VTVM to Output Jacks.

Mode

CONTROL BUTTON - Playback
MONITOR SW - TAPE
DOLBY NR SW - OUT
TAPE SELECTOR SW - CrO₂

Adjustment

Adjust the Playback Head Azimuth Alignment Screw to obtain the maximum reading on VTVM. Be sure to check both channels. The maximum reading should be more than 70mV on VTVM when Playback Calibration is adjusted correctly.

7.9. Bias Oscillator Frequency

Measurement Connection

Frequency Counter to CN1-9 (Main P.C.B.) - GND

Mode

CONTROL BUTTON - Record/Pause

Adjustment

Adjust the Bias Oscillator Coil T351 to obtain a reading of 105kHz on Frequency Counter.

T351 - Main P.C.B.

Note: Measurement shall be made by use of a low capacity probe.

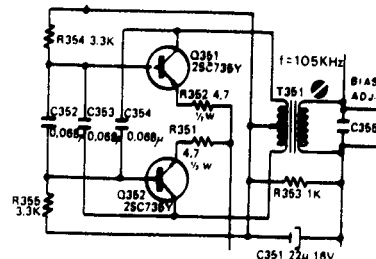

Fig. 7.9



7.10. Bias Trap (Bias Leakage)

Measurements shall be made by use of a low capacity probe.

7.10.1. Record Amp. bias Trap

Measurement Connection

- VTVM to Q153 Collector (Main P.C.B.) - GND. (Lch)
- Q253 Collector (Main P.C.B.) - GND. (Rch)

Mode

CONTROL BUTTON - Record/Pause

Adjustment

Adjust the Bias Trap Coils L152, 252 to obtain the minimum reading on VTVM.

L152 (L ch), L252 (R ch) - Main P.C.B.

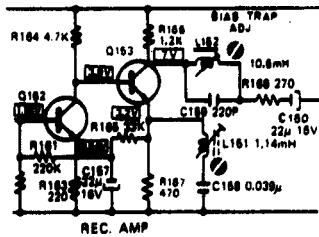

Fig. 7.10

7.10.2. Playback Amp. bias Trap

Measurement Connection

- VTVM to Test Point TP3 (Main P.C.B.) - GND. (Lch)
- TP4 (Main P.C.B.) - GND. (Rch)

Mode

MONITOR SW - TAPE

CONTROL BUTTON - Record/Pause

Adjustment

Adjust the Bias Trap Coils L101, 201 to obtain the minimum reading on VTVM.

L101 (L ch), L201 (R ch) - P.B. Head AMP. P.C.B. Refer to Fig. 7.8.

7.11. Recording Equalization Peaking

Signal Source

1kHz and 23kHz 0.3V to Input Jacks or 1kHz and 23kHz 0.1V to DIN Input.

Measurement Connection

- VTVM to Test Point
- Rec. Head (L) (Main P.C.B.) - GND (L ch)
- Rec. Head (R) (Main P.C.B.) - GND (R ch)

Mode

MONITOR SW - SOURCE

DOLBY NR SW - OUT

MPX SW - OFF

TAPE SELECTOR SW - CrO₂

CONTROL BUTTON - Record/Pause

Bias Cut (Disconnect bias cut jumper in the Fig. 11. 1. Main P.C.B.)

Adjustment

- (1) Adjust the line input level controls to obtain 0 dB on Level Meters at 1kHz input signals.
- (2) Feed in 23kHz instead of 1kHz then adjust L151, 251 to obtain peak reading (about 13 dB rise at 20kHz).

L151 (L ch), L251 (R ch) - Main P.C.B.

Note: Refer to the Fig. 7.10. frequency response.

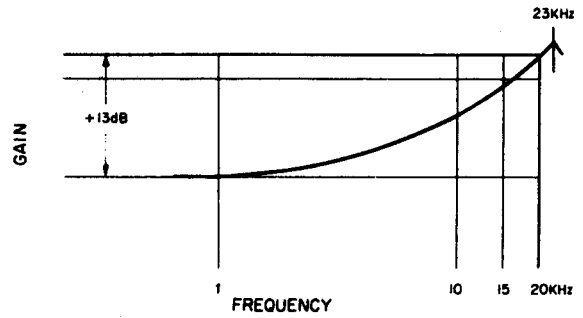

Fig. 7.11

7.12. Alignment Beacon Phase Adjustment

Before starting adjustment, be sure to adjust the Record Head Azimuth by Record Head Azimuth Alignment Beacon whenever cassette tapes are changed (even when cassette tape is changed from A-side to B-side).

Signal Source

Reference CrO₂ Tape (DA09009A)

15kHz 0.03V to Input Jacks or 15kHz 0.01V to DIN Input.

Mode

CONTROL BUTTON - Record/Pause

MONITOR SW - CrO₂

400Hz TEST TONE SW - OFF

Adjustment

- (1) Adjust the Record Head Azimuth Alignment Screw to obtain the maximum reading on VTVM. Be sure to check both channels.
- (2) Set 400Hz TEST TONE SW to ON.
- (3) Adjust VR601 so that Alignment Beacon will fricker alternately.

VR601 Logic Control P.C.B.

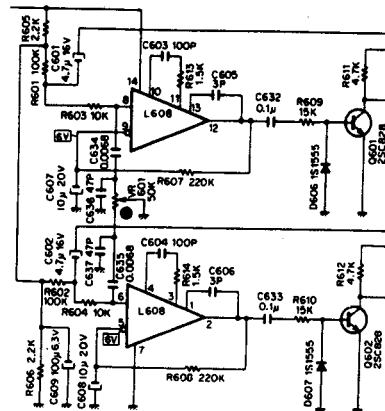

Fig. 7.12

7.13. Record Bias and Record/Playback Level

Signal Source

1KHz 0.3V to Input Jacks. 1KHz 0.03V (-20dB), 18KHz 0.03V (-20dB) (20KHz 0.03V (-20dB)) to Input Jacks.

Measurement Connection

VTVM & Distortion Meter to Output Jacks or DIN Output.

Mode

CONTROL BUTTON - Record/Playback

MONITOR SW - SOURCE

TAPE SELECTOR SW - NORMAL or CrO₂

LIMITER SW - OFF

DOLBY NR SW - OUT

MPX SW - OFF

Adjustment

- (1) Load a Reference EX Tape (DA09010A) (Reference CrO₂ Tape (DA09009A)) and set TAPE SELECTOR SW to NORMAL (CrO₂).
- (2) Set to TEST TONE SW ON and set to record mode, and adjust the record head azimuth alignment.
- (3) Set MONITOR SW to TAPE, and adjust the Bias ADJ. VR154, 254 (VR153, 253) to obtain the maximum reading on VTVM.
- (4) Adjust the Record Calibration VR152, 252 (VR151, 251) to obtain same level on Level Meters (0 dB) at MONITOR SW SOURCE and TAPE.
- (5) Set MONITOR SW to SOURCE and TEST TONE SW to OFF. Feed in 1kHz 0.3V to Input Jacks and adjust the line input level controls to obtain 0 dB on Level Meters.
- (6) Set MONITOR SW to TAPE. Set Audio Generator Output Level to 18kHz -20dB (CrO₂: 20kHz -20dB). Adjust the Bias ADJ. VR154, 254 (VR153, 253) so that level would become within ±3dB against 1kHz.
- (7) Set MONITOR SW to TAPE. Feed in 1kHz 0.3V to Input Jacks and adjust the line input level controls to obtain 0dB on Level Meters. And check the Total Harmonic Distortion (T.H.D.) will be under 2%. If T.H.D. exceeds 2%, adjust the Bias ADJ. VR154, 254 (VR153, 253) again to obtain T.H.D. of less than 2%. Then set Audio Generator Output Level to 18kHz -20dB (CrO₂: 20kHz -20dB) and check to insure level would become within ±3dB against 1kHz.
- (8) For correction of Record Calibration after above adjustment, set to TEST TONE SW ON and set to record mode. Then adjust Record Calibration VR152, 252 (VR151, 251) to obtain same level on Level Meters (0 dB) at MONITOR SW SOURCE and TAPE.

Note 1: "7.12. Alignment Beacon Phase Adjustment" has to be conducted.

Note 2: In case of defective Frequency Response, the following causes can be considered:

Defective Record Head, defective "7.7. Playback Frequency Response" check and Playback Head, defective "7.11. Recording Equalization Peaking" check, defective Mechanical Adjustments (Head Height Adjustment, Tape Travelling).

Refer to 7.21. in case frequency response is waving.

- VR154 (NORMAL-Lch) Bias ADJ. VR
- VR254 (NORMAL-Rch) Bias ADJ. VR
- VR153 (CrO₂-Lch) Bias ADJ. VR
- VR253 (CrO₂-Rch) Bias ADJ. VR
- VR152 (NORMAL-Lch) Rec. Cal. Control VR
- VR252 (NORMAL-Rch) Rec. Cal. Control VR
- VR151 (CrO₂-Lch) Rec. Cal. Control VR
- VR251 (CrO₂-Rch) Rec. Cal. Control VR

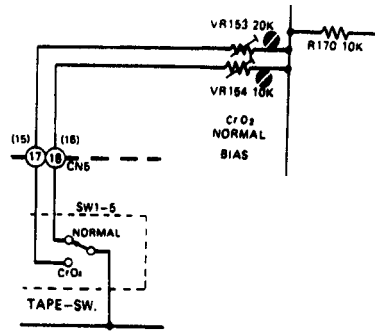

Fig. 7.13

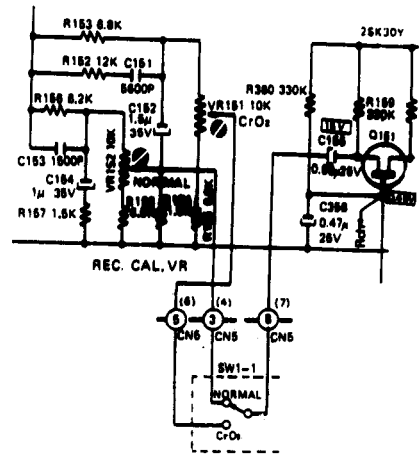

Fig. 7.14

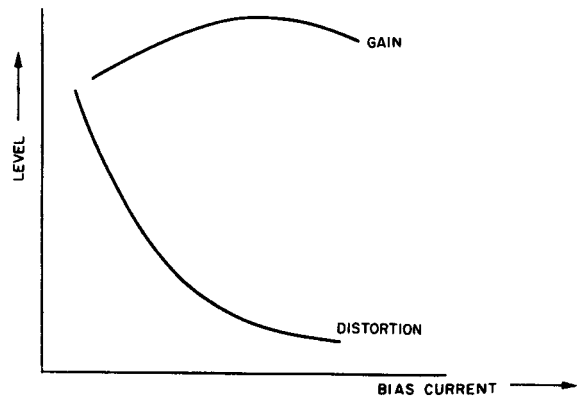

Fig. 7.15

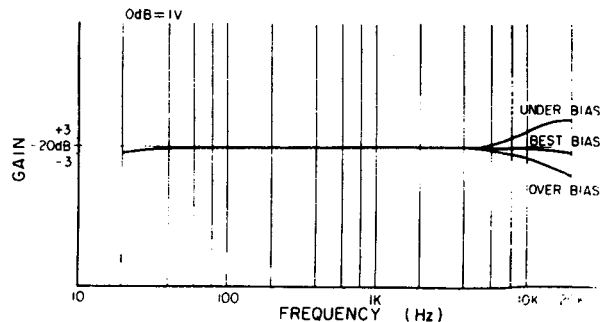

Fig. 7.16



7.14. Record Dolby Board

Adjust only if board is repaired.

- (1) Set Law Control VR101 (VR201) to maximum clockwise, viewed from top side.
- (2) Set Gain Control VR102 (VR202) fully counterclockwise.
- (3) Set DOLBY NR SW to OUT and short FET gate Test Pin Lch (Rch) to ground.
- (4) Feed in 5kHz at a level to give 3mV at Metering terminal.
- (5) Note signal level obtained at Output terminal.
- (6) Set DOLBY NR SW to IN and adjust Gain Control for a 10dB rise at Output terminal.
- (7) Note output level with DOLBY NR SW In.
- (8) Remove FET gate Test Pin short and adjust Law Control for a 2dB drop at Output terminal.

Note: Pin number of Record Dolby P.C.B.

	RIGHT ch	LEFT ch
DOLBY NR SW terminal	2	13
Metering terminal	3	12
Output terminal	5	10
Input terminal	4	11

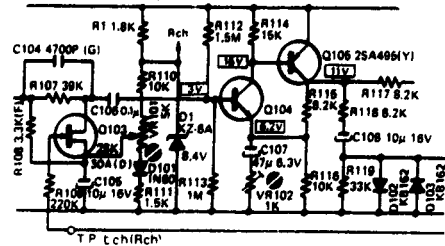

Fig. 7.18

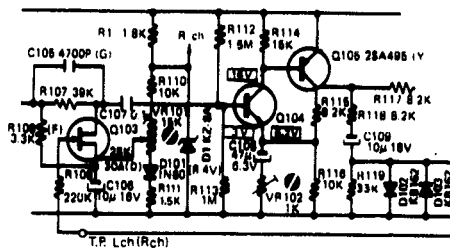

Fig. 7.17

7.15. Playback Dolby Board

Adjust only if board is repaired.

- (1) Set Law Control VR101 (VR201) to maximum clockwise, viewed from top side.
- (2) Set Gain Control VR102 (VR202) fully counterclockwise.
- (3) Set DOLBY NR SW to OUT and short FET gate Test Pin Lch (Rch) to ground.
- (4) Feed in 5kHz at a level to give 7.6mV at Metering terminal.
- (5) Set Gain Control for a 10dB drop at Metering terminal as DOLBY NR SW is set to IN.
- (6) Set DOLBY NR SW to OUT and remove FET gate Test Pin short and adjust Law Control to give a reading of 3mV at Metering terminal.

Note: Pin numbers of Playback Dolby P.C.B.

	RIGHT ch	LEFT ch
DOLBY NR SW terminal	2	13
Metering or Output terminal	5	10
Input terminal	3	1

7.16. Signal to Noise Ratio Measurement

- (1) Connect VTVM, oscilloscope and distortion meter to the output jacks, and then connect the oscillator to line input jacks.
- (2) Set the Dolby NR switch shall be set to OUT.
- (3) Record and playback 400Hz and adjust the line input level controls till the distortion becomes 3%.
- (4) Set the Dolby NR switch to IN at the recording level in (3) as above.
- (5) Disconnect the oscillator form input jacks.
- (6) After reword, playback once again and check the output difference between (4) and (5).

Note: The filter of CCITT Curve shall be used in the measurement.

7.17. Channel Separation Measurement

7.17.1. L channel to Right channel

- (1) Connect a VTVM and oscilloscope to the output jacks, and connect the oscillator to the line input jacks of L channel.
- (2) Set the Dolby NR switch to OUT.
- (3) Load a blank cassette tape.
- (4) Set the monitor switch to source and adjust the L ch line input level control till the meters indicate 0dB at 1KHz. Set the R ch line input level control to maximum.
- (5) Set the monitor switch to tape and record.
- (6) After reword, play it back.
- (7) Measure the difference between L and R channels.

7.17.2. Right Channel to L Channel

- (1) Connect an oscillator to the input jacks of R channel.
- (2) Set the monitor switch to source and adjust the R ch line input level control till the meters indicate 0dB at 1KHz.
- (3) The L ch line input level control shall be set to maximum.
- (4) Set the monitor switch to tape and record it.
- (5) After reword, play it back.
- (6) Measure the output difference between R and L channels.

7.18. Crosstalk Measurement

- (1) Connect a VTVM, oscilloscope and 1KHz band pass filter to the output jacks, and then connect the oscillator to the line input jacks.
- (2) Load a blank cassette tape.
- (3) Set the monitor switch to source, and then adjust the line input level controls till the meters indicate 0dB at 1KHz.
- (4) Set the monitor switch to tape and record it.
- (5) Turn the cassette tape the other way round and play it back, when measurement shall be made at 1KHz B.P.F.
- (6) Measure the output difference between (4) and (5) (R channel of A (or B) side to R channel of B (or A) side).

7.23. Adjustments Table

No.	Operation	Remarks
1	Take-up Torque Fast Wind Torque	As per 6.1.1. 40 ± 10g-cm As per 6.1.2. Should not less than 50g-cm
2	Tape Travelling Check	As per 6.4.
3	Tape Speed	As per 7.1. 1-7/8 ips. ± 1%
4	Meter Calibration Level	As per 7.2. 0dB on level meters, at 100mV ± 2mV on test point TP1, TP2
5	400Hz Test Tone	As per 7.3. 0dB on level meters
6	19kHz MPX Filter	As per 7.4. Minimum reading at 19KHz
7	Limiter Level	As per 7.5. +4dB decrease by 1dB
8	P.B. Level Calibration	As per 7.6. (Adjust when P.B. Head is replaced.) 0dB on level meters at 400Hz P.B. Reference Tape
9	P.B. Frequency Response	As per 7.7. (Adjust when P.B. Head is replaced.) -20dB ± 3dB against 400Hz P.B. Reference Tape at 10, 15, 20KHz P.B. Reference Tape
10	Head Azimuth Alignment (P.B. Head)	As per 7.8. (Adjust when P.B. Head is replaced.) Maximum reading
11	Bias Oscillator Frequency	As per 7.9. (Adjust when Erase Head is replaced.) 105KHz ± 3KHz
12	Bias Trap (Record Amp. Playback Amp.)	As per 7.10.1. and 7.10.2 Minimum reading
13	Recording Equalization Peaking	As per 7.11. (Adjust when Rec. Head is replaced.) Peak reading at 23KHz, at bias cut mode
14	Alignment Beacon Phase Adjustment	As per 7.12.
15	Record Bias and Record/Playback Level	As per 7.13. (Adjust when P.B. Head or Rec. Head is replaced.) Frequency Response: -20dB ± 3dB Distortion: Less than 2%
16	Record Dolby NR Board Playback Dolby NR Board	As per 7.14. As per 7.15.
17	Signal to Noise Ratio	As per 7.16. Better than 60dB (Dolby NR IN, Wrms CCITT 400Hz 3% T.H.D.)
18	Channel Separation	As per 7.17. Better than 35dB at 1KHz 0dB
19	Cross Talk	As per 7.18. Better than 60dB at 1KHz 0dB
20	Erasure	As per 7.19. Better than 60dB at 1KHz, saturation level
21	Total Harmonic Distortion	As per 7.20.
22	Wow/Flutter	As per 7.21. Less than 0.1% (DIN45507 Weighted Peak)

9. TROUBLE SHOOTING

9.1. Note

- (1) Check to insure whether the outputs +12V, +17V and +5V of the logic control are correct.
- (2) In general logics, the output high level is not less than 2.4V, and output low level not more than 0.4–0.5V.
The output between 0.4–2.4V does not belong either to "L" or "H", and is generated if TTL IC is damaged or over-loaded (This voltage is called "Half Level").
The threshold level of the TTL IC is shown to be less than 1.1–0.8V while "L" level, and more than 1.9V–2.0V while "H" level.
Normally, if the input is open, it is regarded as high level.
- (3) The logic control board if separated from the chassis does not activate accurately as its grounding is also separated, therefore check thereon shall be made upon connecting the grounding of the PCB control and chassis with a jumper wire both ends of which are provided with a clip (particularly when an extension cord is used).
- (4) When a check is made on Amp. etc. by means of an extension cord, re-adjustment shall be made without fail (after final installation to the model chassis).
The check without removal of an extension cord will cause inaccurate adjustments.
- (5) Either Nakamichi CrO₂ or EX tape shall be used while adjustments (particularly while adjustments of bias and record/playback level).
Should another difference branded tape be used in its place, the set shall previously be adjusted according to each of the actual tape in use.
However, if low quality tape should be used, optimum quality of a set will not be obtained (such as distortion, S/N, Dynamic Range, etc. will be deteriorated).

9.2 Trouble Shoots

9.2.1. Main motor does not rotate:

- (1) Defective motor governor.
- (2) Defective main motor.
- (3) Pitch control volume is out of accuracy.
- (4) The lead wire between governor and motor is cut.
- (5) The lead wire between the governor and pitch control volume is cut.
- (6) +12V is not being supplied to the governor.

9.2.2. Auto Shut-off does not work (at tape end):

- (1) One of D401 through D402 is defective (excessive ripple of +12V)
- (2) Shut-off driver is defective.
- (3) Shut-off sensor is defective.
- (4) +12V regulator is defective (excessive ripple of +12V).

9.2.3. Auto Shut-off activates (other than tape end):

- (1) Shut-off belt is cut.
- (2) Shut-off sensor is defective.
- (3) Take-up torque is too weak.
- (4) Defective shut-off driver.
- (5) Pressure roller spring is not at the correct position.

9.2.4. Beacon does not flicker:

- (1) IC 607 is defective.
- (2) IC 608 is defective.
- (3) Defective playback head.
- (4) Defective playback head amp.
- (5) Defective record head.

- (6) Defective L.E.D.
- (7) Tape travel is incorrect.
- (8) Defective Record Eq. Amp.

9.2.5. Does not Shut-off while FF, Rew (at tape end):

- (1) Defective IC603.
- (2) Defective IC604.

9.2.6. Remained only in Play mode:

- (1) Defective IC605.
- (2) Defective IC606.
- (3) The driver of the head base solenoid is defective.
- (4) Defective control switch ass'y.
- (5) Defective head base solenoid.

9.2.7. Remained only in Record mode:

- (1) Defective IC601.
- (2) Defective IC602.
- (3) Defective IC603.
- (4) Defective control switch ass'y.

9.2.8. Remained only in Rewind mode:

- (1) Defective control switch ass'y.
- (2) Defective IC606.
- (3) Either RY601 or driver is defective.

9.2.9. Remained only in Fast Forward mode:

- (1) Defective control switch ass'y.
- (2) Defective IC606.
- (3) Either RY602 or driver is defective.

9.2.10. Remained only in Pause mode:

- (1) Defective IC601.
- (2) Defective IC603.
- (3) Defective IC604.
- (4) Defective control switch ass'y.

9.2.11. Does not change to Play mode:

- (1) Defective control switch ass'y.
- (2) Defective IC605.
- (3) Defective IC606.
- (4) Head base solenoid and driver are defective.
- (5) Auto shut-off driver is defective.
- (6) Head base is not operating accurately (when heavy).
- (7) Reel drive mechanism is not operating accurately.
- (8) Defective take-up reel.
- (9) Defective cassette tape (hard to rotate, etc.).
- (10) Pressure roller spring is out of the correct position.

9.2.12. Does not change to Record mode:

- (1) Control switch ass'y is not operating accurately.
- (2) Defective record protect switch.
- (3) Defective IC601.
- (4) Defective IC602.
- (5) Defective IC603.

9.2.13. Does not rewind:

- (1) Control switch ass'y is not operating accurately.
- (2) Defective IC606.
- (3) RY601 and driver are defective.
- (4) Defective reel motor.
- (5) Pulley of the reel motor is too loose.
- (6) Defective reel derive mechanism ass'y.
- (7) RY602 and driver are defective.

7.19. Erasure Measurement

- (1) Connect a VTVM and oscilloscope to the output jacks and connect the oscillator to the line input jacks.
- (2) Set the monitor switch to source, and adjust the line input controls till the meters indicate 0dB at 400Hz.
- (3) Load a blank cassette tape.
- (4) Set the monitor switch to tape and record it.
- (5) Then rewind it.
- (6) Disconnect the oscillator from the line input jacks.
- (7) Record it once again (erase).
- (8) Then rewind.
- (9) Measure the output difference between (4) and (7).

7.20. Total Harmonic Distortion Measurement

- (1) Connect a distortion meter to the output jack, and then connect an oscillator to line input jacks.
- (2) Set the Oscillator to 1KHz and then set the model to 0dB by means of line input level controls (In this case, the monitor switch shall be set to source).
- (3) Load a test tape (blank tape) and record (monitor switch to be set to source).
- (4) Check the reading of the distortion meter.

Note: In performing the above, the Dolby NR switch shall be set to OUT, and check shall be made to insure whether recording level is correct (Calibration while test tone switch on shall be done previously without fail). Output level controls shall be set to maximum.

7.21. Wow/Flutter Measurement

- (1) Connect a wow/flutter meter to the output jack.
 - (2) Load a 3KHz speed-wow/flutter tape (DA09006A) and play it back.
 - (3) Check the reading of wow/flutter meter.
- Note: DIN weighted peak shall be measured.

7.22. Adjustment and Measurement of Frequency Response

The method of measuring frequency response in this item refers to the case where waving is generated. The Dolby Noise Reduction System shall be effected at OUT.

7.22.1. Adjustment of Playback Frequency Response

- (1) Open the 39K ohms of R111, 211. (EQ and time constant shall show 120 μ s).
- (2) Load a 400Hz Level Tape (DA09005A) to playback, and turn the output level controls to till the indication of the VTVM shows (0dB for example) and easy reference of value.
- (3) Load a 10KHz P.B.F.R. tape (DA09003A) and play it back.
- (4) Check the output of 10KHz and then adjust EQ in the range of 110 μ s - 140 μ s the result of which shall be 0 - +3dB. Refer to Fig. 7. 19. "Playback Equalizer".
- (5) Load a 15KHz P.B.F.R. tape (DA09002A) and play it back.
- (6) If the output of 15KHz shows the value within \pm 2dB, it shall be considered satisfactory.
- (7) Load a 20KHz P.B.F.R. tape (DA09001A) and play it back.
- (8) If 15KHz at (5) shows the value within \pm 2dB and 20KHz being less than -3dB, check shall be made on C101, 201 with 0 - 220PF. Refer to Fig. 7.20. "Compensation of Playback High Frequency Response".
- (9) Adjustment shall be made so that 10KHz, 15KHz and 20KHz will become flat when compared with 400Hz.
- (10) If the results are shown to belong to high, set R101, 201 to open -220K ohms.

- (11) Adjust the azimuth alignment to the maximum output with a 15KHz azimuth alignment tape (DA09004A).

Note 1: If adjustment is made on the jumper resistor, the alignment beacon phase shall also be adjusted.

Note 2: If the foregoing adjustments do not suffice the requirements, the playback head shall be replaced.

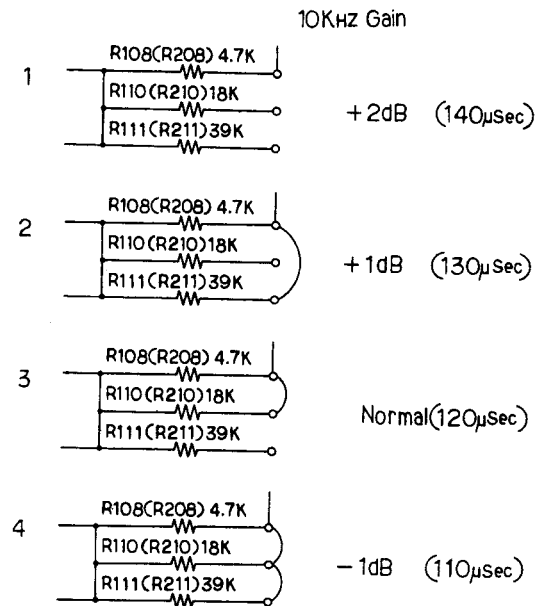

Fig. 7.19

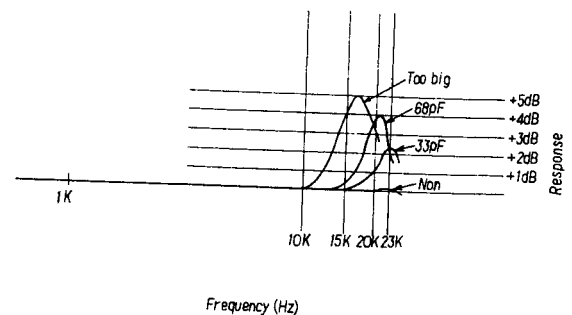

Fig. 7.20

7.22.2. Adjustment of Overall Frequency Response

- (1) Set the tape selector switch to CrO₂ and then load reference CrO₂ tape (DA09009A).
- (2) Connect the audio generator to input jacks and connect a VTVM and oscilloscope to output jacks.
- (3) Set the Nakamichi 700 to record/pause.
- (4) Set the monitor switch to source and adjust the line input level controls till the meters indicate 0dB at 1KHz 0.3V from the generator.
- (5) While the above state, lower the output of the oscillator by 30dB.
- (6) Set to record/play. Set the oscillator to 15KHz from 1KHz and then adjust the azimuth alignment of the record head.
- (7) Adjustment shall be made on bias till the response at 10KHz becomes 0dB (± 1 dB).
- (8) Adjustment shall be made on peaking coils L151, L251 till the response at 20KHz becomes 0dB (± 2 dB).
- (9) Waving with a CrO₂ tape at 1KHz - 20KHz shall be not more than 3dB.
- (10) If waving exceeds 3dB, apply 22K ohms in parallel with R152, 252 of the main P.C.B. and repeat the items (7) thorough (9). Refer to Fig. 7.21. "Record Equalizer for CrO₂".
- (11) Adjust the azimuth alignment to the maximum output with a 15KHz azimuth alignment tape (DA09004A) azimuth alignment of record head (record/play).
- (12) Bias shall be adjusted till the response at 10KHz becomes 0dB (± 1 dB)
- (13) Measure the response at 18KHz (± 2 dB)
- (14) Change the output of the oscillator from -30dB to -20dB and check the frequency response.
- (15) Measure the distortion at 1KHz 0dB Overall.
CrO₂ - less than 2%
EX - less than 2.5%
- (16) In case of excessive distortion, change the record head.

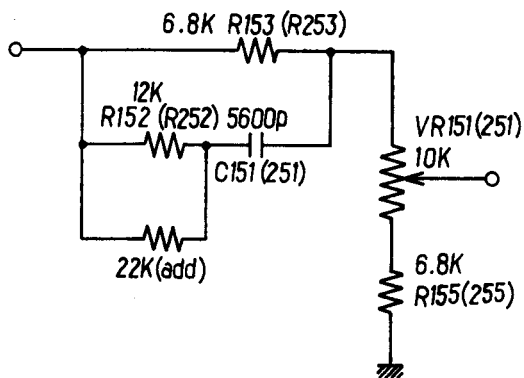
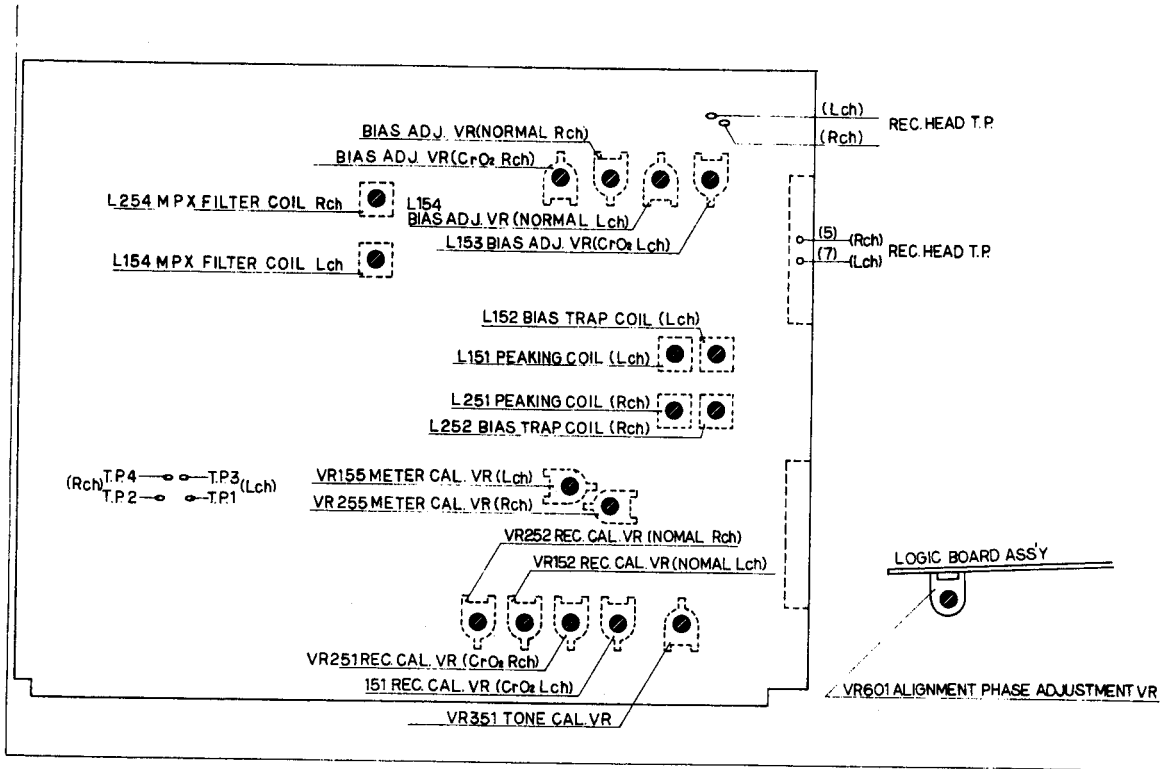
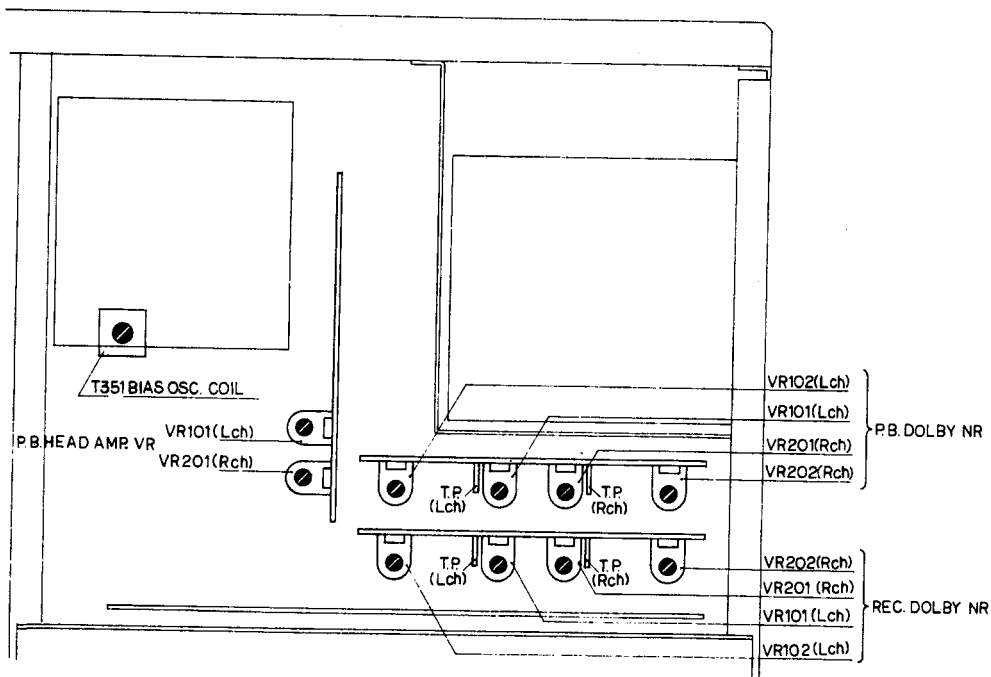

Fig. 7.21



REAR VIEW

Fig. 8.1



FRONT VIEW

Fig. 8.2

- (8) Defective brake solenoid driver.
- (9) Defective brake solenoid.

9.2.14. Does not Fast Wind:

- (1) Defective control switch ass'y.
- (2) Defective IC606.
- (3) RY602 and drive are defective.
- (4) Defective reel motor.
- (5) Pulley of the reel motor is too loose.
- (6) Defective reel drive mechanism ass'y.
- (7) RY602 and driver are defective.
- (8) Brake solenoid driver is defective.
- (9) Defective brake solenoid.

9.2.15. Does not pause:

- (1) Control switch ass'y is defective.
- (2) Defective IC603.
- (3) Defective IC604.
- (4) Defective IC602.
- (5) Head base solenoid and driver are defective.

9.2.16. Brake does not operate:

- (1) Defective solenoid.
- (2) Defective solenoid driver.
- (3) Defective IC606.
- (4) RY601 and driver are defective.
- (5) RY602 and driver are defective.

9.2.17. Head base solenoid does not operate:

- (1) Defective solenoid.
- (2) Defective head base switch ass'y.
- (3) Defective solenoid driver.
- (4) Defective IC602.
- (5) Defective IC605.
- (6) Defective IC606.
- (7) Head base is not operating accurately (when heavy).

9.2.18. Record mode operates without cassette tape:

- (1) Incorrect adjustment of record protect switch.
- (2) Defective IC601.
- (3) Defective IC602.
- (4) Defective IC603.

9.2.19. Logic Control does not operate:

- (1) +5V not being induced.
- (2) Cassette sensor switch is defective.
- (3) Incorrect adjustment of cassette sensor switch.
- (4) Defective control switch ass'y.
- (5) 19P connector is out of contact.

9.2.20. Tape speed is too fast:

- (1) Defective motor governor.
- (2) Defective generator.
- (3) Lead wire of sensor is cut.
- (4) Incorrect adjustment (semi-fixed VR).

9.2.21. Indications lamp does not light:

- (1) Defective lamp.
- (2) Lamp driver is defective.

9.2.22. Does not playback:

- (1) Playback head is defective.
- (2) Defective PB head amp. ass'y.
- (3) Defective PB Dolby Ass'y.
- (4) Defective line amp. ass'y.
- (5) Dirty PB head.
- (6) Mute is not operating.
- (7) Wire between playback head and 10P connector is cut.

9.2.23. Does not record:

- (1) Defective record Eq. amp. ass'y.
- (2) Defective record head.
- (3) Defective record Dolby Ass'y.
- (4) Bias oscillation is not generating.
- (5) Defective Mic. amp. ass'y.
- (6) Defective 19kHz MPX filter.
- (7) Incorrect tape travel.
- (8) Either capstan or pressure roller is dirty.
- (9) Dirty playback head.
- (10) Remained only in mute.
- (11) Cut lead wire between record head and 10P connector.

9.2.24. Bias does not oscillate:

- (1) No voltage to bias oscillation circuit.
- (2) Defective bias oscillation circuit.
- (3) Defective erase head.

9.2.25. Does not erase:

- (1) Defective erase head.
- (2) Dirty erase head.
- (3) Bias is not oscillating.
- (4) Incorrect tape travel.

9.2.26. Level variations:

- (1) Incorrect tape travel.
- (2) Defective pressure roller.
- (3) Variation of take-up torque.
- (4) Defective erase head guide (including incorrect adjustment).
- (5) Dirty capstan or pressure roller.
- (6) Defective flywheel ass'y.
- (7) Incorrect adjustment of pressure roller.
- (8) Record head and playback head are out of correct alignment.
- (9) Defective playback head.
- (10) Defective record head.
- (11) Incorrect adjustment of flywheel thrust screws.

9.2.27. Tape folds:

- (1) Tape guide is in incorrect position.
- (2) Pressure roller is not in the right position against capstan.
- (3) Head mount base is bent.
- (4) Dirty capstan.
- (5) Defective pressure roller.
- (6) Defective cassette tape (non-uniformity of magnetic surface).
- (7) Defective cassette housing.

9.2.28. Unable to secure correct level while record/playback:

- (1) Distorted.
- (2) Defective record head.
- (3) Defective playback head.
- (4) Defective record eq. amp.
- (5) Defective playback amp.
- (6) Incorrect adjustment of playback head amp.
- (7) Playback head and record head are not in correct alignment.
- (8) Incorrect tape travel.

- 9.2.29. Great mechanical noise:
- (1) Defective pressure roller.
 - (2) Defective reel drive mechanism.
 - (3) Defective motor.
 - (4) Flywheel is defective.
 - (5) Defective counter.
- 9.2.30. Sound is distorted:
- (1) Playback head is dirty.
 - (2) Record head is dirty.
 - (3) Head is magnetized.
 - (4) Record head is defective.
 - (5) Playback head is defective.
 - (6) Bias oscillator circuit is defective.
 - (7) Excessive high level at Record/Playback.
- 9.2.31. Signal to Noise ratio is deteriorated:
- (1) PB Head is magnetized.
 - (2) Bias leakage.
 - (3) Excessive ripple from power source.
 - (4) Either PB head or Rec. Head is defective.
 - (5) Defective PB head amp. (Noise level is great).
 - (6) Defective record amp. (Noise level is great).
- 9.2.32. High frequency is deteriorated:
- (1) Misalignment of Record head.
 - (2) Record head is dirty.
 - (3) Playback head is dirty.
 - (4) Defective Playback head.
 - (5) Defective Record head.
 - (6) Head(s) is(are) magnetized.
 - (7) Incorrect bias adjustment (against tape).
 - (8) Defective 19KHz MPX Filter.
- 9.2.33. Induction of Wow/flutter:
- (1) Defective capstan belt.
 - (2) Defective flywheel ass'y.
 - (3) Defective capstan flange.
 - (4) Defective pressure roller ass'y.
 - (5) Defective motor (main motor).
 - (6) Variation of take-up torque.
 - (7) Abnormality of back tension.
 - (8) Drive part(s) is(are) dirty.
 - (9) Slippage between pressure roller and tape.
 - (10) Defective reel drive mechanism ass'y.
- 9.2.34. Meters do not flutter:
- (1) Meters themselves are defective.
 - (2) Defective meter amp.
 - (3) Tape is not played back.
 - (4) Neither being recorded nor monitored.
 - (5) Meter lead is shorted.
 - (6) Meter lead is cut.
- 9.2.35. No power transmission:
- (1) Defective power cord.
 - (2) Defective power switch.
 - (3) Defective change-over plug and socket.
 - (4) Defective main transformer.
 - (5) Defective DC supply circuit.
- 9.2.36. Ineffective mute:
- (1) No mute signal from logic board.
 - (2) Defective mute driver.
 - (3) Defective record amp.
 - (4) Defective PB Head Amp.
- 9.2.37. No oscillation of 400Hz:
- (1) Defective oscillation circuit.
 - (2) Defective test tone switch
 - (3) Shorted lead between test tone switch and main board.
 - (4) Cut lead between test tone switch and main board.
- 9.2.38. Tape speed is too slow:
- (1) Defective motor governor.
 - (2) Defective main motor.
- 9.2.39. Remained in mute mode:
- (1) Continuous generation of mute signals from logic board.
 - (2) Defective mute driver.
 - (3) Defective record amp.
 - (4) Defective playback head amp.
- 9.2.40. Defective memory rewind:
- (1) Defective tape counter.
 - (2) Defective memory switch.
 - (3) Defective driver of memory rewind.
- 9.2.41. No activation of tape counter:
- (1) Defective tape counter.
 - (2) Defective counter belt.
- 9.2.42. Sound distorts at Limiter Switch On:
- (1) Incorrect adjustment of limiter circuit.
 - (2) Defective limiter circuit;
 - (3) Defective limiter switch.
- 9.2.43. Unsatisfactory sound at Dolby In:
- (1) Record/playback level is away from correct level (0 dB).
 - (2) Incorrect adjustment of Record Dolby.
 - (3) Incorrect adjustment of Playback Dolby.
 - (4) Incorrect bias adjustment (to tape).
 - (5) Defective Record Dolby.
 - (6) Defective Playback Dolby.
 - (7) Incorrect playback gain(400Hz P/B level tape(DA09005A)).
- 9.2.44. Pneumatic damper ineffective:
- (1) Defective pneumatic damper.
 - (2) Defective mechanism (heavy or does not work).
 - (3) Incorrect adjustment of damper.

9.3. Check Method When Parts are Replaced.

When any part/part ass'y of the Nakamichi 700 is replaced with new one, please check to insure the following:

9.3.1. When main motor is changed:

- (1) Tape speed.
- (2) Wow/flutter.

9.3.2. When pressure roller is changed:

- (1) Tape travelling.
- (2) Azimuth/height.
- (3) Tape speed.
- (4) Wow/flutter.

9.3.3. When erase head is replaced:

- (1) Tape travelling.
- (2) Azimuth/height
- (3) Bias osc. frequency.
- (4) Erasure performance.
- (5) Bias adjustment (overall frequency response).
- (6) Bias leakage.

9.3.4. When record head is replaced:

- (1) Azimuth/height.
- (2) Record track position.
- (3) Bias adjustment (overall frequency response check).
- (4) Adjustment of level at 0dB with 400Hz test tone.
- (5) Check distortion when 1KHz is recorded and played back at 0dB.
- (6) Bias leakage check.
- (7) Phase check (between left and right).

9.3.5. When playback head is replaced:

- (1) Azimuth/height.
- (2) Tape travelling.
- (3) Track position in regard to that of record head.
- (4) Adjustment of playback gain (with test tape at 0dB).
If unable to adjust to 0dB, please adjust R123,223 at 3.3K (P.B. Head Amp. P.C.B.) to:
if strong — make R stronger
if weak — make R weaker
- (5) Frequency response check by playback (with test tapes).
- (6) Frequency response check by overall (with reference tape).
- (7) Gain check by overall (with reference tape).
- (8) Phase check (between left and right).

9.3.6. When flywheel ass'y is replaced:

- (1) Tape travelling.
- (2) Azimuth/height.
- (3) Tape speed.
- (4) Wow/flutter.

9.3.7. Reel drive mechanism ass'y is replaced:

- (1) Torque check while F/F, Rew, and Play.
- (2) Mechanical noise check while F/F, Rew, and play, but without a tape.
- (3) Tape speed.
- (4) Wow/flutter.

9.3.8. When meters are replaced:

- (1) Adjustment of meter level.

9.3.9. When sub-motor is replaced:

- (1) Torque check while F/F and Rew.

9.3.10. When drive belt is replaced:

- (1) Wow/flutter.
- (2) Tape speed.

9.3.11. When motor governor is replaced:

- (1) Tape speed.
- (2) Wow/flutter.

9.3.12. When tape counter is replaced:

- (1) Tape speed.
- (2) Wow/flutter.
- (3) Memory rewind.
- (4) Counter check (sticky, etc.)

9.3.13. When pneumatic damper is replaced:

- (1) Damper speed check.

9.4. Table for Common Use of Semi-Conductors

Symbol	Manufactures	Countries
TII	Texas Instruments Incorporated	U.S.A.
GESY	General Electric Company	U.S.A.
FSC	Fairchild Semiconductor Division	U.S.A.
MOTA	Motorola Semiconductor Products	U.S.A.
RCA	Radio Corporation of America	U.S.A.
SPR	Sprague Electric Company	U.S.A.
NSC	National Semiconductor Corporation	U.S.A.
APX	Amperex Electronic Corporation	U.S.A.
SSI	Solid State Devices Incorporated	U.S.A.
RAYN	Raytheon Company	U.S.A.
SIC	Signetics Corporation	U.S.A.
SIEG	Siemens Aktiengesellschaft	Germany
TFKG	Allgemeine Elektrizitäts-Gesellschaft Telefunken	Germany
PHIN	Philips Gloelampenfabrieken Eindhoven	Netherlands

2SC735 (TOSHIBA)	TII-2N2432 GESY-2N3391, 2N3416, 2N3417, 2N3707, 2N3708, 2N3709, 2N3710, 2N3711, 2N5088, 2N5089 FSC-2N3566, SE6001, SE6002 SIEG-BCY58 TFKG-BSW88, BSW89
2SC732 (TOSHIBA), 2SC900E (NEC)	TII-2N3707, 2N3708, 2N3709, 2N3710, 2N3711 GESY-2N3391, 2N3900 SIEG-CB167, BFY47, BFY48, BFY49 TFKG-CB149, BF254, BF255 MOTA-2N5088, 2N5089, MPS6520, MPS6521, MPS6522, MPS6523 RCA-40231, 40232, 40233
2SC828 (MATSUSHITA)	TII-2N3710 GESY-2N3391A FSC-2N3566 SIEG-BC121, BC122, BC123, BC128 TFKG-BC129 MOTA-MPS3727, MPS6514, MPS6515, MPS6575, MPS6576, 2N3903 APX-BC147
2SC1096 (NEC)	GESY-D42C2, D42C3, D42C4 SIEG-BSX62 MOTA-2N4237, 2N4238 RCA-2N1479, 2N1481, 2N1700, 40310, 40372, 40594, 40595 APX-A208, A253, A273 PHIN-BFY51
2SC945 (NEC), 2SC373 (TOSHIBA)	TII-A3T929, A3T930, A5T4125 GESY-2N2711, 2N2712, 2N3391A, 2N5127, 2N5132 FSC-SE2001, SE2002 TFKG-BC130 MOTA-MPS2711, MPS2712, MPS3392, MPS3393, MPS3394, MPS3395, MPS3396, MPS3397, MPS6512, MPS6513, 2N2256
2SC1000 (TOSHIBA)	SIEG-BC167, BC168, BC169, BFY47, BFY48, BFY49 TFKG-BC131, BC149, BF254, BF255 MOTA-2N5088, 2N5089, MPS3707, MPS6553, MPS6555, MPS6571 RCA-40231, 40232, 40233

2SA495 (TOSHIBA)	TII-A3T2894 FSC-2N4248, 2N5138 SIEG-BC257, BC258, BC259 TFKG-BC157, BC158, BC159 MOTA-2N3905, 2N3906, MPS3702, MPS3703 PHIN-BCZ13, BCZ14
2SA733 (NEC)	PHIN-BSU96, BSU98, 2N1303, 2N1309
2SA634 (NEC)	GESY-D43C2, 2N3913, 2N3914, 2N3915, 2N4413, 2N4415 RAYN-2N3910, 2N3911, 2N3912
M53200P (MITSUBISHI)	SIC-N7400A TII-SN7400N SIEG-FLH101 HITACHI-HD2503 TOSHIBA-TD3400P
M53210P (MITSUBISHI)	SIC-N7410A TII-SN7410N SIEG-FLH111 HITACHI-HD2507 TOSHIBA-TD3410P
M53220P (MITSUBISHI)	SIC-N7420A TII-SN7420N SIEG-FLH121 HITACHI-HD2504 TOSHIBA-TD3420P
M53274P (MITSUBISHI)	SIC-N7474A TII-SN7474N SIEG-FLJ141 HITACHI-HD2510 TOSHIBA-TD3474P
RC4558 (RAYTHEON)	TII-SN72558P MOTA-MC1458 NSC-LM1458
RC4709 (RAYTHEON)	MOTA-MC1437P

Schematic Ref. No.	Part No.	Description	Schematic Ref. No.	Part No.	Description
BA-3606 Main P.C.B. Ass'y			- 400Hz Osc. -		
- Rec. Amp. -			- Meter -		
Q151,251	B-1600	FET	Q357	B-6005	Transistor
Q152,252	B-6005	Transistor	T352	B-3879	Trans.
153,253			VR351	B-1596	Semi-fixed Volume
355,356			R361	B-5664	Carbon Resistor
D351,352	B-1909	Silicon Diode	R362	B-5665	Carbon Resistor
353			R363	B-1888	Carbon Resistor
L151,251	B-3858	Peaking Coil	R364	B-5559	Carbon Resistor
L152,252	B-3859	Bias Trap Coil	R365	B-5645	Carbon Resistor
VR151,251	B-1595	Semi-fixed Volume	C360,362	B-1405	Electrolytic Capacitor
152,252			C361	B-5551	Mylar Capacitor
R152,252	B-5650	Carbon Resistor	C359	B-1412	Electrolytic Capacitor
R153,253	B-1877	Carbon Resistor	Q154,254	B-6005	Transistor
155,255			155,255		
158,258			D151,251	B-6058	Zener Diode
R154,254	B-1830	Carbon Resistor	D152,252	B-6007	Silicon Diode
R156,256	B-1878	Carbon Resistor	VR155,255	B-1805	Semi-fixed Volume
R157,257	B-5505	Carbon Resistor	R174,274	B-5591	Carbon Resistor
R159,259	B-1921	Carbon Resistor	R177,277	B-5648	Carbon Resistor
160,260			R178,278	B-1920	Carbon Resistor
360			R179,279	B-1833	Carbon Resistor
R161,261	B-5596	Carbon Resistor	R180,280	B-5544	Carbon Resistor
R162,262	B-5595	Carbon Resistor	R181,281	B-5766	Carbon Resistor
R163,263	B-5608	Carbon Resistor	R812,282	B-5511	Carbon Resistor
R164,264	B-1795	Carbon Resistor	R369	B-5576	Carbon Resistor
R165,265	B-1879	Carbon Resistor	C165,265	B-5636	Tantalum Capacitor
R166,266	B-5565	Carbon Resistor	C166,266	B-5657	Tantalum Capacitor
R167,267	B-1792	Carbon Resistor	C365	B-1272	Electrolytic Capacitor
R168,268	B-5651	Carbon Resistor	L153,253	B-3919	Inductor
R358	B-5566	Carbon Resistor	L154,254	B-3857	19KHz Coil
R359	B-5661	Carbon Resistor	R173,273	B-5629	Carbon Resistor
R368	B-5558	Carbon Resistor	R175,275	B-5648	Carbon Resistor
C151,251	B-5659	Mylar Capacitor	R367	B-1680	Carbon Resistor
C152,252	B-5639	Tantalum Capacitor	C161,261	B-5666	Mylar Capacitor
C153,253	B-5653	Mylar Capacitor	C162,262	B-1802	Mylar Capacitor
C154,254	B-5638	Tantalum Capacitor	164,264		
C155,255	B-1320	Aluminium Capacitor	C163,263	B-1804	Mylar Capacitor
156,256			C167,267	B-1288	Ceramic Capacitor
C157,257	B-5636	Tantalum Capacitor	C363,364	B-1401	Electrolytic Capacitor
C158,258	B-5660	Mylar Capacitor	BA-3562	19P Connector Sub Ass'y	
C159,259	B-1289	Ceramic Capacitor	BA-3703	10P Connector Ass'y	
C160,C260	B-1862	Electrolytic Capacitor	BA-3702	14P Connector Ass'y	
C357	B-5584	Mylar Capacitor	J-3186	Level Control Stud	
C358	B-1376	Aluminum Capacitor	J-3368	Calibration Knob	
C364	B-1401	Electrolytic Capacitor	M-3355	Level Control Panel	
- Bias Osc. -			B-7604	Main P.C.B.	
Q351,352	B-1338	Transistor	B-3924	Gate Pin	
Q353	B-6024	Transistor	B-8001	Tub	
Q354	B-1367	Transistor	E-157	Washer 3 Colair	
L351	B-3861	Inductor	E-254	Washer 3.1 Mylar	
T351	B-6515	Osc. Coil	E-507	Nut Hex M3	
VR153,253	B-1923	Semi-fixed Volume	E-599	Screw M3x10 Philips Pan Head	
VR154,254	B-1595	Semi-fixed Volume			
R151,251	B-5663	Carbon Resistor			
R169,269	B-1833	Carbon Resistor			
170,270					
R176,276	B-5562	Carbon Resistor			
R351,352	B-5662	Carbon Resistor			
R353	B-1781	Carbon Resistor			
R354,355	B-1793	Carbon Resistor			
R356	B-5761	Cement Resistor			
R357	B-1830	Carbon Resistor			
C351	B-1862	Electrolytic Capacitor			
C352,C353	B-5586	Mylar Capacitor			
354					
C355	B-5634	S.P. Capacitor			
C356	B-1404	Electrolytic Capacitor			

10. MECHANISM ASSEMBLY / PARTS LIST

Note: Where serial numbers are shown underneath the modified assemble, the modifications apply to those serial numbers only. But if no serial numbers, then no modifications have been made from the initial production.

10.1. Synthesis Assembly (A01)

Note: After serial number 3709323, Head Mount Base Ass'y (CA-5075) have been changed to the Head Mount Base (E) Ass'y (CA-5168) as detailed in the item 10.31.

Schematic Ref. No.	Part No.	Description	Q'ty
A01	TT-700	Synthesis	1
01	JA-3016	Chassis Ass'y	1
02	CA-5159	Mechanism Ass'y 700	1
03	JA-3018	Control Button Ass'y (A)	1
04	J-3200	P.C.B. Holder Stud	3
05	H-3248	Switch Button	5
06	H-3188	Button Sheet BC	5
07	J-3282	Panel Stopper	1
08	HA-3598	Front Panel Ass'y	1
09	HA-3606	Control Button Play Ass'y	1
10	HA-3605	Control Button Stop Ass'y	1
11	HA-3602	Control Button Rewind Ass'y	1
12	HA-3604	Control Button F.F. Ass'y	1
13	HA-3601	Control Button Record Ass'y	1
14	HA-3603	Control Button Pause Ass'y	1
15	HA-3627	Control Panel Ass'y	1
16	A-3157	Front Sash	1
17	HA-3609	VR Knob Ass'y	1
19	H-3250	VR Knob (T)	3
19	H-3251	VR Knob (B)	3
20	H-3366	Voltage Selector Cover Washer	2
21	H-3334	Voltage Selector Acrylic Cover	1
22	H-3335	Voltage Selector Cover SO	1
23	HA-3599	Cabinet Ass'y	1
24	HA-3600	Lid Cover Ass'y	1
25	HA-3608	A.J. Lid Ass'y	1
L01	E-622	Screw M3x5 Philips Pan Head (2A)	4
L02	E-633	Screw M4x6 Philips Pan Head (3A)	8
L03	E-606	Screw M3x6 Philips Pan Head (3A)	8
L04	E-121	Screw M2.6x6 Philips Pan Head	3
L05	E-591	Screw M3x20 Philips Pan Head	2
L06	E-141	Washer 4	4
L07	E-568	Screw M4x15 Philips Pan Head	4

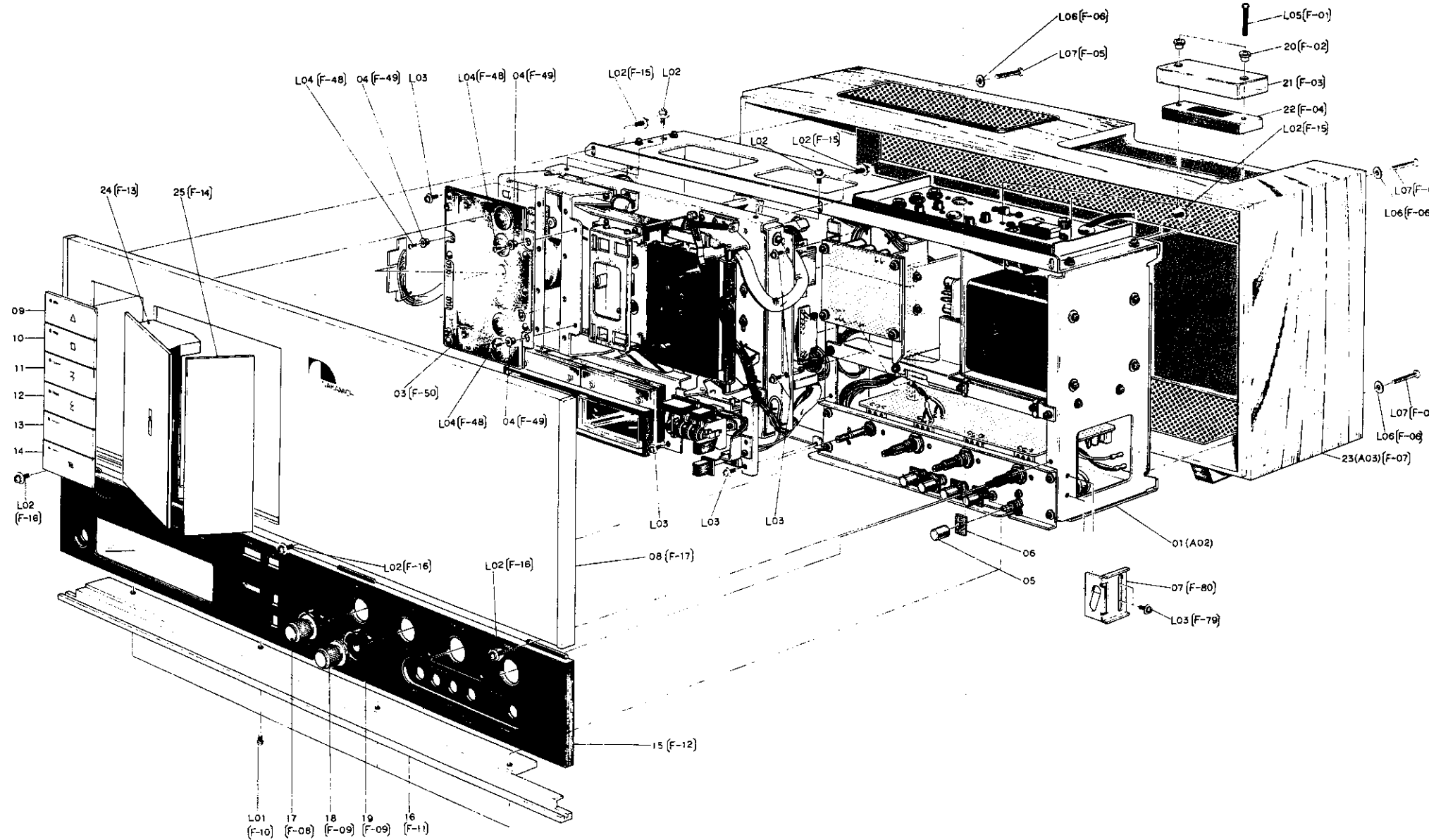

Serial No. 3708651-3709322

Fig. 10.1

10.2. Chassis Assembly (A02)

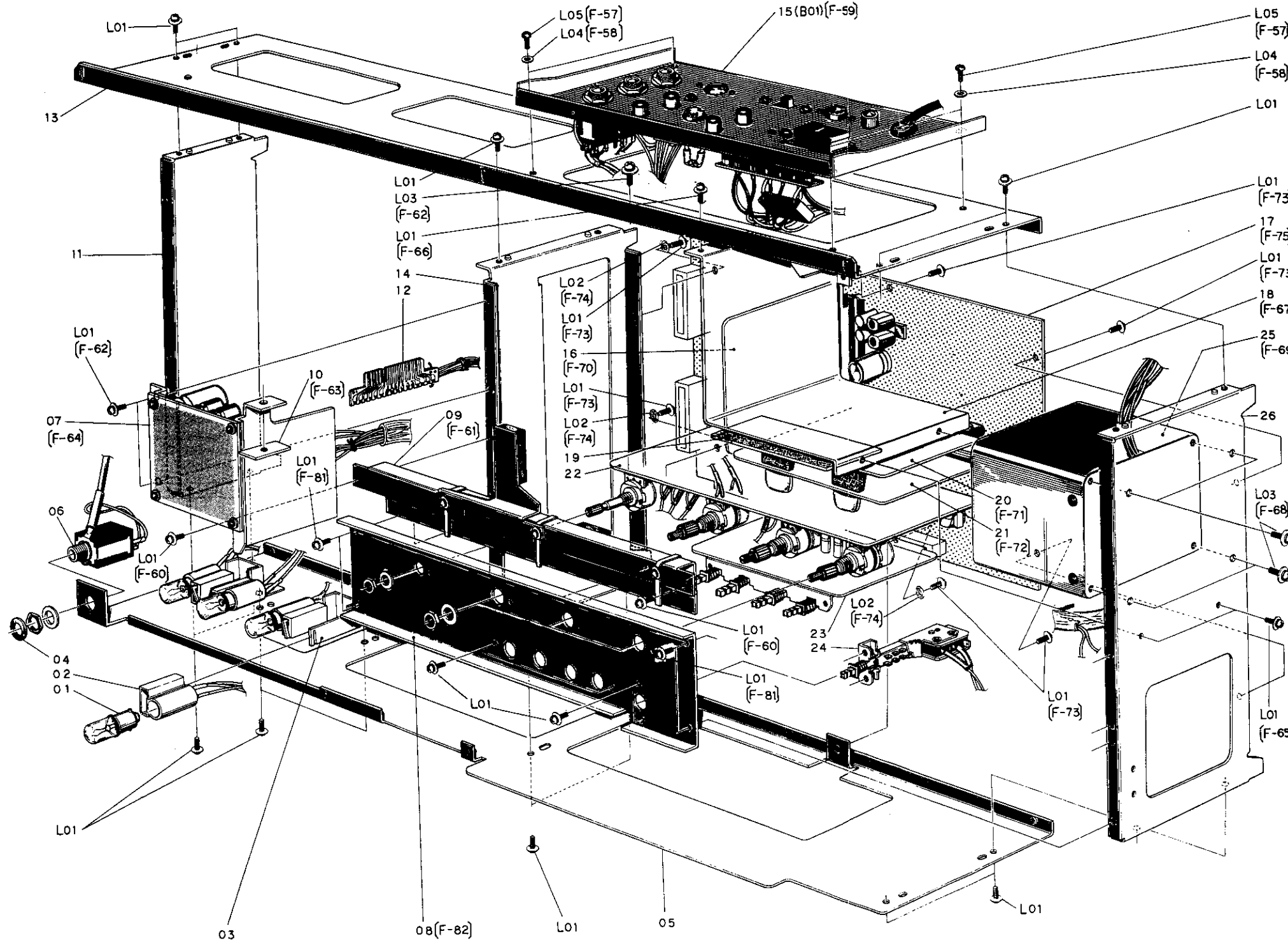

Schematic Ref. No.	Part No.	Description	Q'ty
A02	JA-3016	Chassis Ass'y	1
01	B-8071 U	Meter Lamp	4
02	B-3565	Lamp Socket	4
03	J-3205	Lamp Bracket	2
04	J-3247	Headphone Black Washer	2
05	J-3178	Front Chassis	1
06	B-8078	Headphone Jack	1
07	BA-3608	Power Supply Ass'y	1
08	J-3172	Control Chassis	1
09	JA-3019	P.C.B. Holder Ass'y	1
10	C-1162	Metal Seat Nut	1
11	J-3174	Side Chassis L	1
12	B-7535	19P Plug P.C.B. (D)	1
13	J-3179	Rear Chassis	1
14	J-3175	Center Chassis	1
15	BA-3610	Rear Panel Ass'y	1
16	BA-3651	P.B. HEAD AMP. Ass'y	1
17	BA-3606	MAIN P.C.B. Ass'y	1
18	J-3176	Transformer Shield Plate	1
19	B-8082	Transformer Shield Insulator	1
20	BA-3588	P.B. Dolby Ass'y	1
21	BA-3589	REC. Dolby Ass'y	1
22	BA-3701	Front Control (A) Ass'y	1
23	BA-3609	Switch Board Ass'y	1
24	B-7005U	Power Switch	1
25	B-6518U	Power Transformer	1
26	J-3173	Side Chassis	1
L01	E-606	Screw M3x6 Philips Pan Head (3A)	35
L02	E-71	Washer 3 Fiber	3
L03	E-634	Screw M4x10 Philips Pan Head (3A)	5
L04	E-157	Washer 3 Collar	4
L05	E-593	Screw M3x6 Binding Head	4

Serial No. 3708651

Fig. 10.2

10.3. Cabinet Assembly (A03)

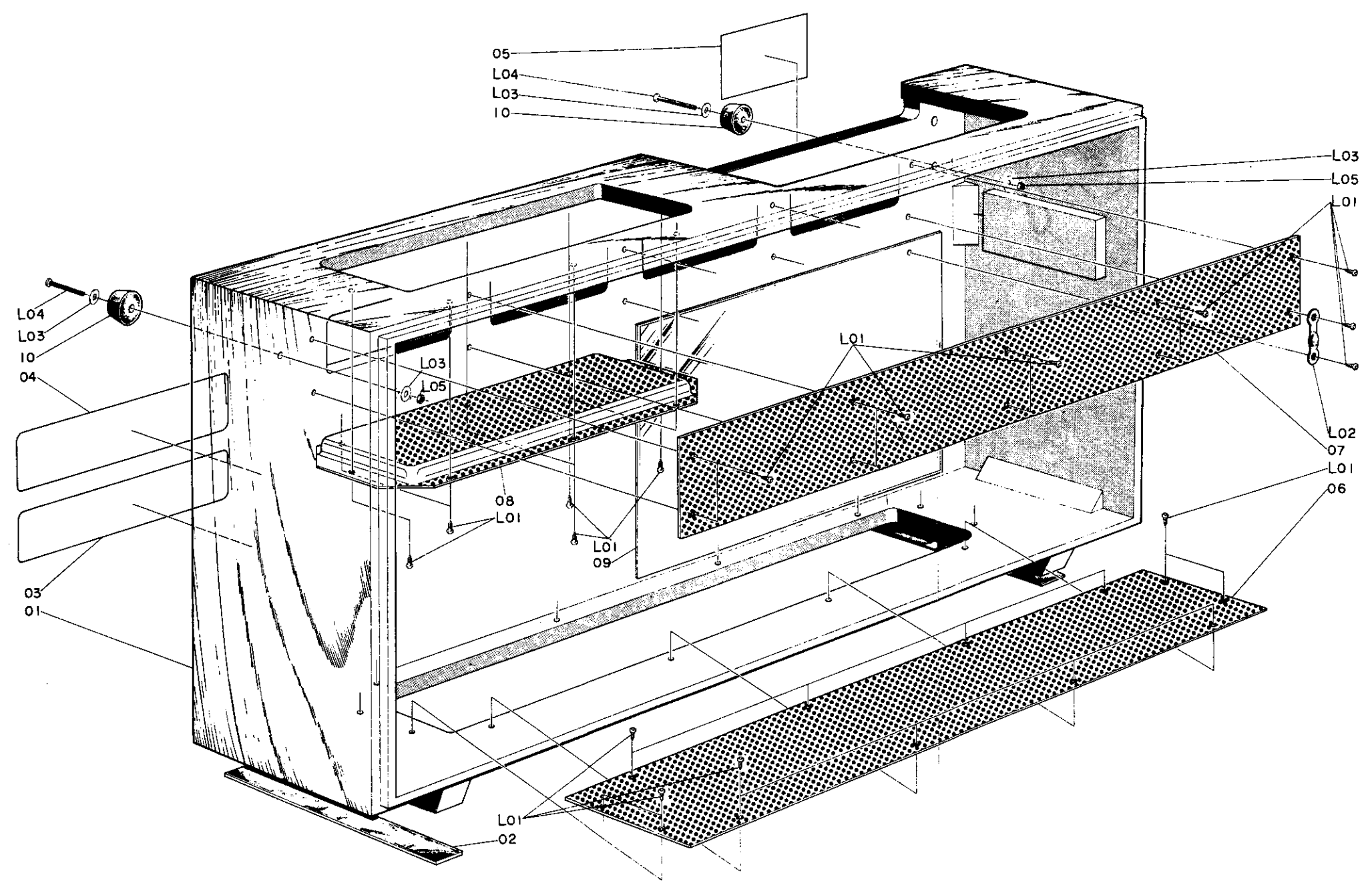

Schematic Ref. No.	Part No.	Description	Qty
A03	HA-3599	Cabinet Ass'y	1
01	A-3173	Cabinet	1
02	H-3286	Cabinet Foot Stopper	2
03	M-3330	Dolby License Label	1
04	M-3339	Caution Label	1
05	M-3369	Model Label	1
06	A-3171	Punching Plate (F)	1
07	A-3172	Punching Plate (G)	1
08	A-3170	Punching Plate (E)	1
09	A-3169	Aluminium Shield (B) Box	1
10	A-42	Foot	2
L01	E-1004	WS 2.4 x 6.3 Round Head	31
L02	E-37	Earth Lug B-5	2
L03	E-178	Washer 3	4
L04	E-577	Screw M3x20 Philips Pan Head	2
L05	E-507	Nut Hex M3	2

Fig. 10.3

10.4. Mechanism Assembly Note: After serial number 3709323, Head Mount Base Ass'y (CA-5075) have been changed to the Head Mount Base (E) Ass'y (CA-5168) as detailed in the item 10.31.

10.4.1. Mechanism Assembly (A04.1)

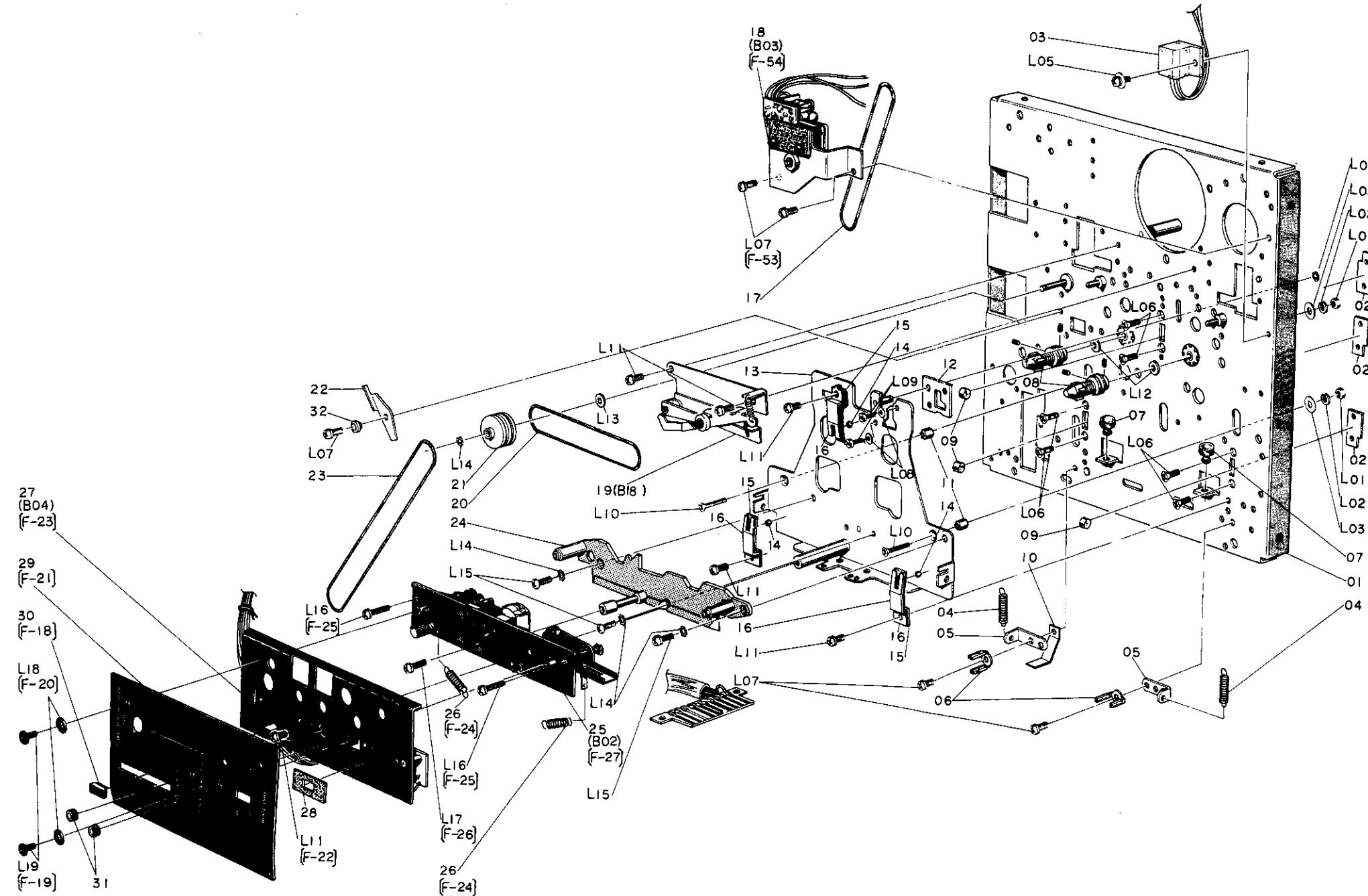

Schematic Ref No.	Part No.	Description	Qty
A04-1	CA-5159	Mechanism Ass'y 700	1
01	CA-5070	Mechanism Chassis Ass'y	1
02	C-5457	Base Roller Holder (A)	3
03	CA-5150	Tape Illumination Lamp	1
04	C-5382	Base Return Spring	2
05	C-5032	Spring Hook	2
06	B-3067	Cord Holder	2
07	C-5101	Base Stopper Rubber	2
08	CA-5051	Reel Hub Ass'y	2
09	C-5456	Base Roller (B)	3
10	C-5364	Lid Arm Spring	1
11	C-5435	Head Base Holder Nut	2
12	C-5484	Head Base Adaptor	1
13	CA-5072	Head Base Ass'y	1
14	C-2024	2 mm Ball	2
15	C-5030	Ball Retainer Spring	3
16	C-5459	Ball Retainer Spring (B)	3
17	C-5465	Shut-off Belt	1
18	CA-5137	Auto Shut-off Ass'y	1
19	CA-5044	Cassette Holder Ass'y	1
20	C-5334	Counter Belt (B)	1
21	C-5335	Guide Pulley	1
22	C-5358	Cassette Eject Linkage (A)	1
23	C-5333	Counter Belt	1
24	CA-5073	Head Adjust Plate Ass'y	1
25	CA-5075	Head Mount Base Ass'y	1
26	C-5178	Pressure Arm Spring	2
27	CA-5115	Mount Base Cover Ass'y	1
28	J-3213	Test Tone Felt	1
29	M-3356	Mount Base Name Plate	1
30	H-3254	Pitch Control Knob	1
31	C-5376	L.E.D. Escutcheon	2
32	C-5135	Center Guide	1
L01	E-21	Nut Hex M3	2
L02	E-26	Washer 2.6 Spring	2
L03	AM-6295	W3-9-0.5F	2
L04	E-222	E-Ring 2	1
L05	E-606	Screw M3x6 Philips Pan Head (3A)	1
L06	E-76	Screw M2.6x4 Philips Flat Head	6
L07	E-612	Screw M3x6 Philips Pan Head (2A)	5
L08	E-29	Washer 2	2
L09	E-2	Screw M2x3 Cylinder Head	2
L10	E-56	Screw M2.6x10 Philips Flat Head	2
L11	E-622	Screw M3x5 Philips Pan Head (2A)	5
L12	C-3174	Washer 2.1 Mylar	2
L13	C-3613	Washer 1.6 Mylar	1
L14	E-172	Washer 3 Out-Toothed	3
L15	E-502	Screw M3x5 Philips Pan Head	3
L16	E-624	Screw M3x10 Philips Pan Head (2A)	2
L17	E-510	Screw M3x8 Pan Head (2A)	1
L18	E-624	Washer 3 Collar	2
L19	E-656	Screw M3x4 Truss Head Bronze	2

Serial No. 3708651-3709322
Fig. 10.4.1

10.4.2. Mechanism Assembly (A04.2)

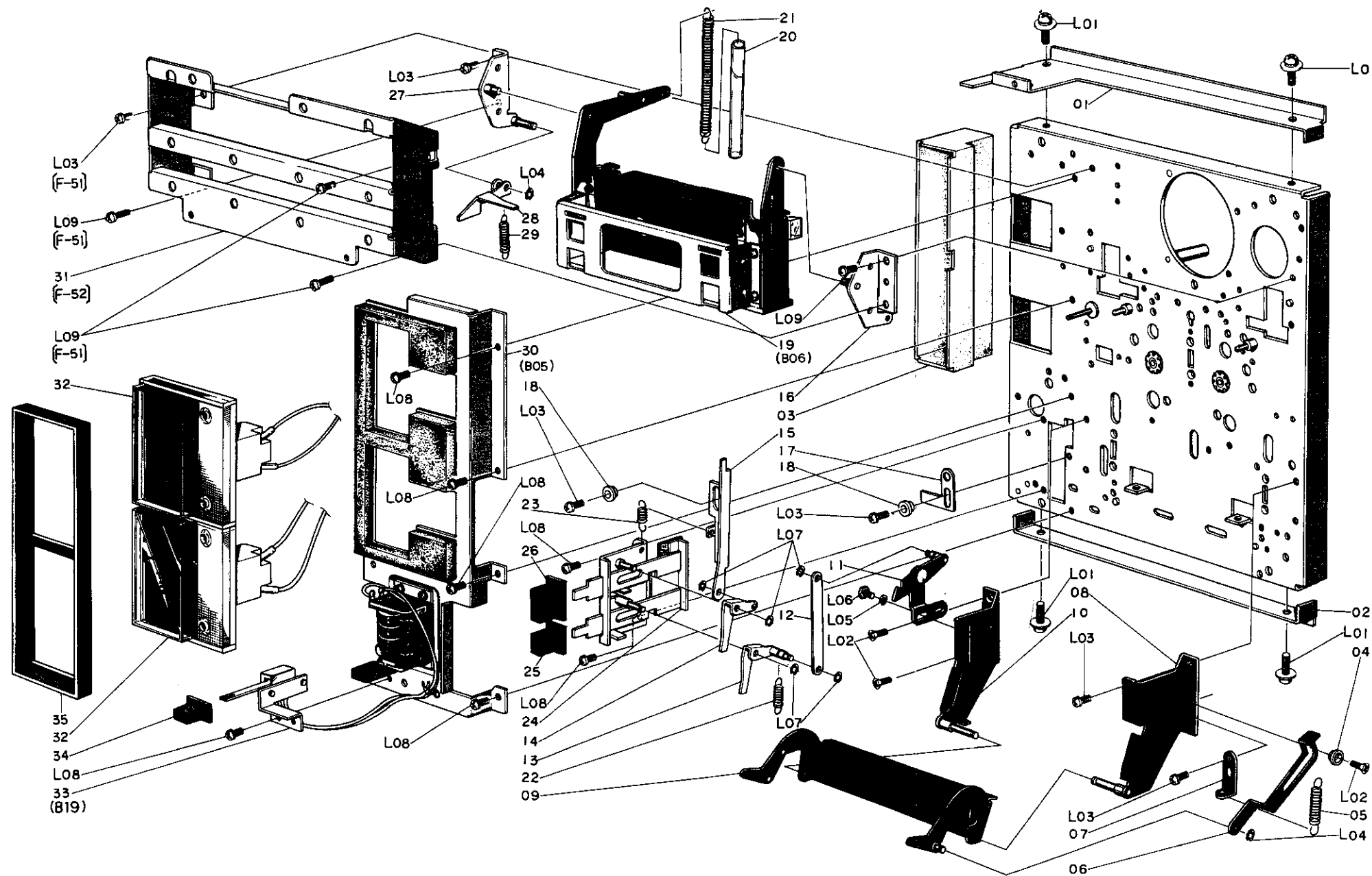

Schematic Ref. No.	Part No.	Description	Q'ty
A04-2	CA-5159	Mechanism Ass'y 700	1
01	J-3177	Mechanism Bracket L	1
02	J-3183	Mechanism Bracket R	1
03	J-3260	Meter Lamp Cover	1
04	C-5473	Center Guide (B)	1
05	C-5425	Lid Arm Spring R	1
06	C-5427	Lid Arm Stopper Plate	1
07	C-5032	Spring Hook	1
08	CA-5109	AJ. Plate Holder L Ass'y	1
09	CA-5118	Lid Arm Ass'y	1
10	CA-5112	AJ. Plate Holder R Ass'y	1
11	CA-5111	AJ. Lock Plate Ass'y	1
12	C-5360	AJ. Eject Linkage	1
13	CA-5108	AJ. Eject Arm Ass'y	1
14	CA-5107	Cassette Eject Arm Ass'y	1
15	C-5359	Cassette Eject Linkage (B)	1
16	CA-5092	Cassette Holder Ass'y R	1
17	C-5367	Eject Stopper	1
18	C-5135	Center Guide	2
19	CA-5148	Cassette Well Ass'y	1
20	C-5536	Well Spring Tube	1
21	C-5123	Well Spring	1
22	C-5336	AJ. Eject Spring	1
23	C-5365	Cassette Eject Spring	1
24	CA-5106	Eject Bar Bracket Ass'y	1
25	H-3247	AJ. Button 700	1
26	H-3246	Eject Button 700	1
27	CA-5091	Case Holder Ass'y L	1
28	C-5116	Sensor Guide R	1
29	C-5127	Well Stopper Spring	1
30	CA-5149	Meter Chassis Ass'y	1
31	J-3195	Button Holder	1
32	B-8115	Level Meter	1
33	BA-3680	Memory Switch Ass'y	1
34	H-3245	Memory Switch Button	1
L01	E-643	Screw M4x8 Philips Pan Head (3A)	4
L02	E-533	Screw M3x5 Flat Head	3
L03	E-612	Screw M3x6 Philips Pan Head (2A)	6
L04	E-222	E-Ring 2	2
L05	E-37	Washer 3 Spring	1
L06	E-643	Bolt M3x5 Hex Head	2
L07	E-42	E-Ring 1.5	5
L08	E-622	Screw M3x5 Philips Pan Head (2A)	7
L09	E-510	Screw M3x8 Philips Pan Head (2A)	4

Serial No. 3708651-3709322
Fig. 10.4.2

10.4.3. Mechanism Assembly (A04.3)

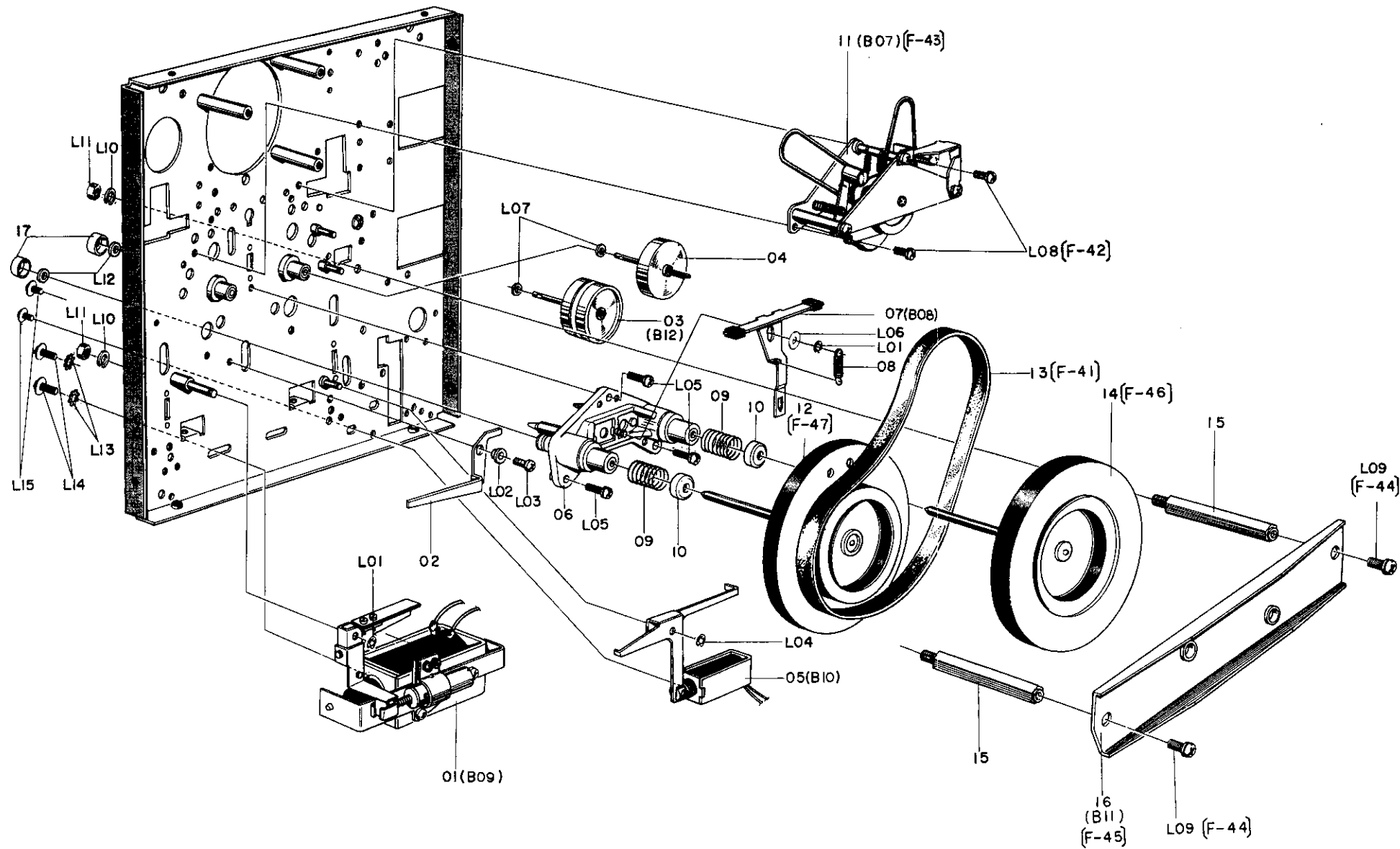

Schematic Ref. No.	Part No.	Description	Q'ty
A04-3	CA-5159	Mechanism Ass'y 700	1
01	CA-5145	Head Base Solenoid Ass'y	1
02	C-5100	Base Switch Arm	1
03	CA-5130	Take-up Pulley Ass'y	1
04	CA-5131	Supply Pulley Ass'y	1
05	CA-5053	Brake Solenoid Ass'y	1
06	CA-5160	Capstan Flange Holder Ass'y C	1
07	CA-5023	Brake Arm Ass'y	1
08	C-5084	Brake Arm Spring	1
09	C-5514	Thrust Spring	2
10	C-5495	Flange Thrust Stud	2
11	CA-5152	Reel Drive Mechanism Ass'y	1
12	CA-5006	Flywheel Ass'y A	1
13	C-5104	Capstan Belt	1
14	CA-5007	Flywheel Ass'y B	1
15	C-5496	Flywheel Holder Stud B	2
16	CA-5171	Flywheel Holder Ass'y	1
17	C-5511	Flange Cap	2
L01	E-181	E-Ring 3	.2
L02	C-5135	Center Guide	1
L03	E-612	Screw M3 x 6 Philips Pan Head (2A)	1
L04	E-222	E-Ring 2	1
L05	E-510	Screw M3 x 8 Philips Pan Head (2A)	3
L06	E-31	Washer 4	1
L07	C-3174	Washer Mylar 2.1	2
L08	E-622	Screw M3 x 5 Philips Pan Head (2A)	2
L09	E-664	Screw M4 x 8 Philips Pan Head (2A)	2
L10	E-574	Washer 4 Spring	2
L11	E-669	Nut Hex M4	2
L12	C-5512	Flange Felt	2
L13	E-172	Washer 3 Toothed	2
L14	E-614	Screw M3 x 6 Triple	2
L15	E-259	Screw M2.6 x 4 Triple	2

Serial No. 3708651-3709322
Fig. 10.4.3

10.4.4. Mechanism Assembly (A04.4)

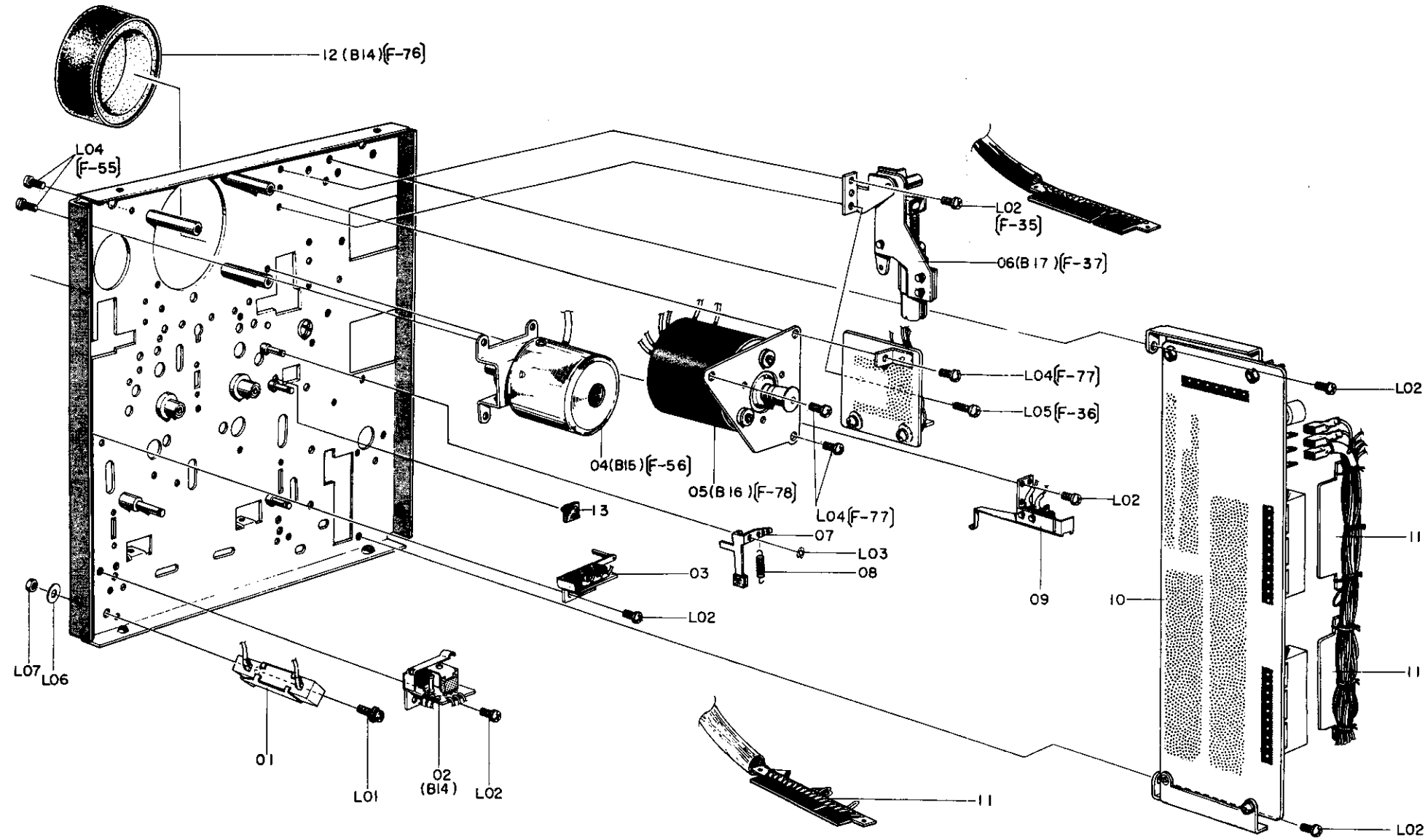

Schematic Ref. No.	Part No.	Description	Qty
A04.4	CA-5159	Mechanism Ass'y 700	1
01	B-5754	Cement Resistor 15Ω 10W	1
02	CA-5132	Base Switch Ass'y A	1
03	CA-5026	Cassette Sensor Ass'y	1
04	CA-5030	Sub-Motor Ass'y	1
05	CA-5154	Main-Motor Ass'y	1
06	CA-5134	Eject Damper Bracket Ass'y	1
07	CA-5024	Back Tension Arm Ass'y	1
08	C-5327	Back Tension Spring	1
09	CA-5031	Record Sensor Ass'y	1
10	BA-3689	Logic Control Ass'y	1
11	B-1798B	19P Plug Board	3
12	CA-5158	Motor Cap Ass'y	1
13	C-5126	Well Stopper Rubber	1
L01	E-607	Screw M3 x 8 Philips Pan Head (2A)	1
L02	E-622	Screw M3 x 5 Philips Pan Head (2A)	6
L03	E-222	E-Ring 2	1
L04	E-612	Screw M3 x 6 Philips Pan Head (2A)	5
L05	E-510	Screw M3 x 8 Philips Pan Head (2A)	1
L06	E-597	Washer 3	1
L07	E-507	Nut Hex M3	1

Serial No. 3708651-3709322

Fig. 10.4.4

10.5. Rear Panel Assembly (B01)

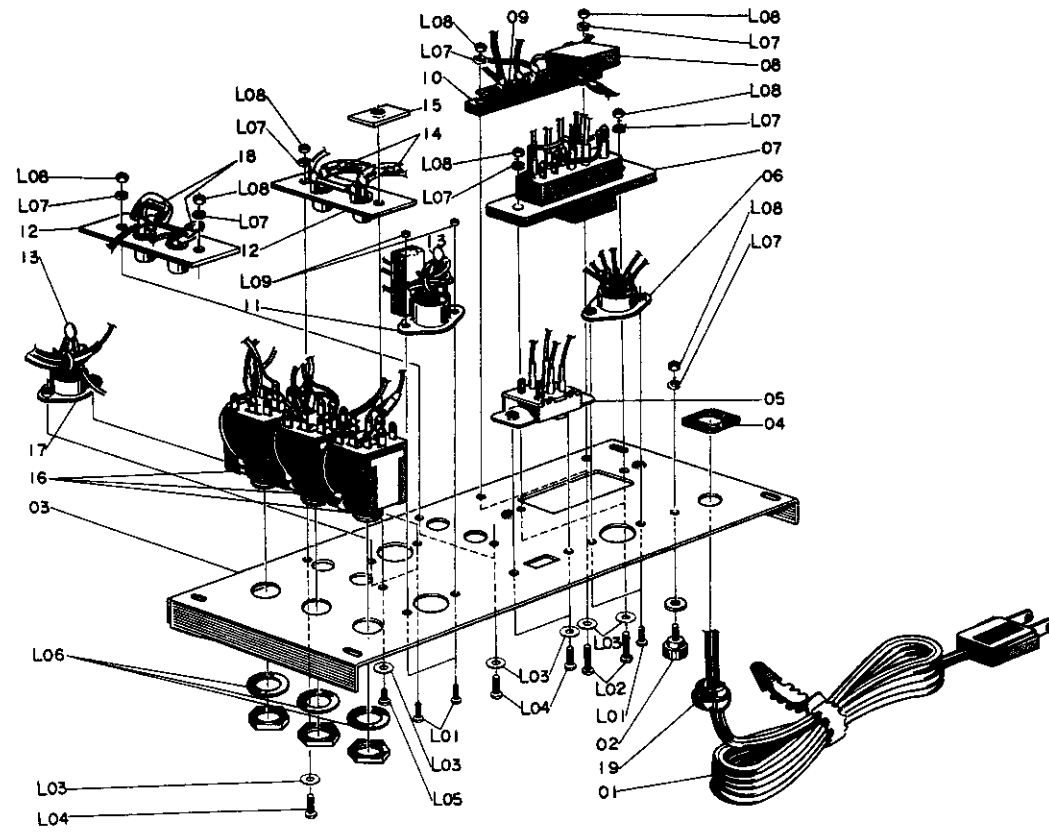

Serial No. 3704501-
Fig. 10.5

Schematic Ref. No.	Part No.	Description	Q'ty	Schematic Ref.No.	Part No.	Description	Q'ty
B01	BA-3610	Rear Panel Ass'y	1	19	B-8073	Cord Bushing	1
01	B-3900U	Power Cord	1				
02	B-3920	Ground Terminal	1	L01	E-588	Screw M2.6x6 Philips Pan Head	6
03	A-3150	Rear Panel	1	L02	E-655	Screw M3x10 Philips Pan Head	1
04	A-3154	Cord Spacer	1	L03	A-3150	Washer 3 Collar	8
05	B-7030	Slide Switch	1	L04	E-588	Screw M3x8 Philips Pan Head	5
06	B-8075	7P DIN Socket	1	L05	E-657	Screw M3x5 Philips Pan Head	1
07	B-3887U	Voltage Selector Socket	1	L06	E-647	Wahser Collar Black	3
08	B-3873U	Spark Killer	1	L07	E-581	Washer 3 Spring	8
09	B-3863	5P Terminal Insulator	1	L08	E-507	Nut Hex M3	8
10	B-8025U	5P Terminal Strip	1	L09	E-21	Nut Hex M2.6	2
11	B-8044	5P DIN Socket With Switch	1				
12	B-3072	2P Pin Jack	2				
13	T-4027	Ceramic Capacitor 680P 50V M	2				
14	B-5688	Carbon Resistor 82K R¼ J	2				
15	J-3248	M3 Seat Nut	1				
16	B-3881	Mixing Mic. Jack	3				
17	B-8074	5P DIN Socket	1				
18	B-1888	Carbon Resistor 10K R¼ J	2				

10.6. Head Mount Base Assembly (B02) (Previous Type)

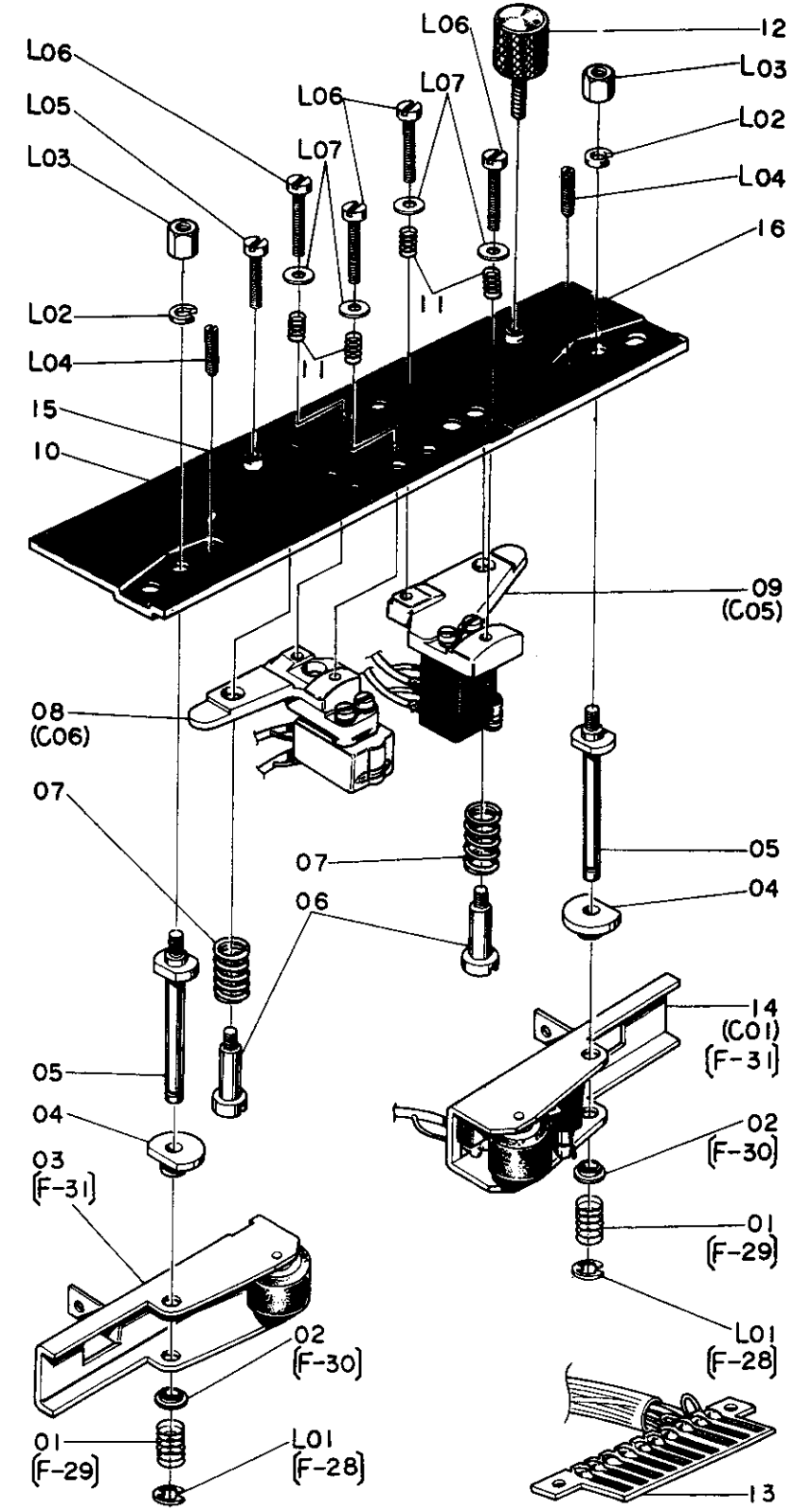

Serial No. 3706201-3709322
Fig. 10.6

10.7. Auto Shut-off Assembly (B03)

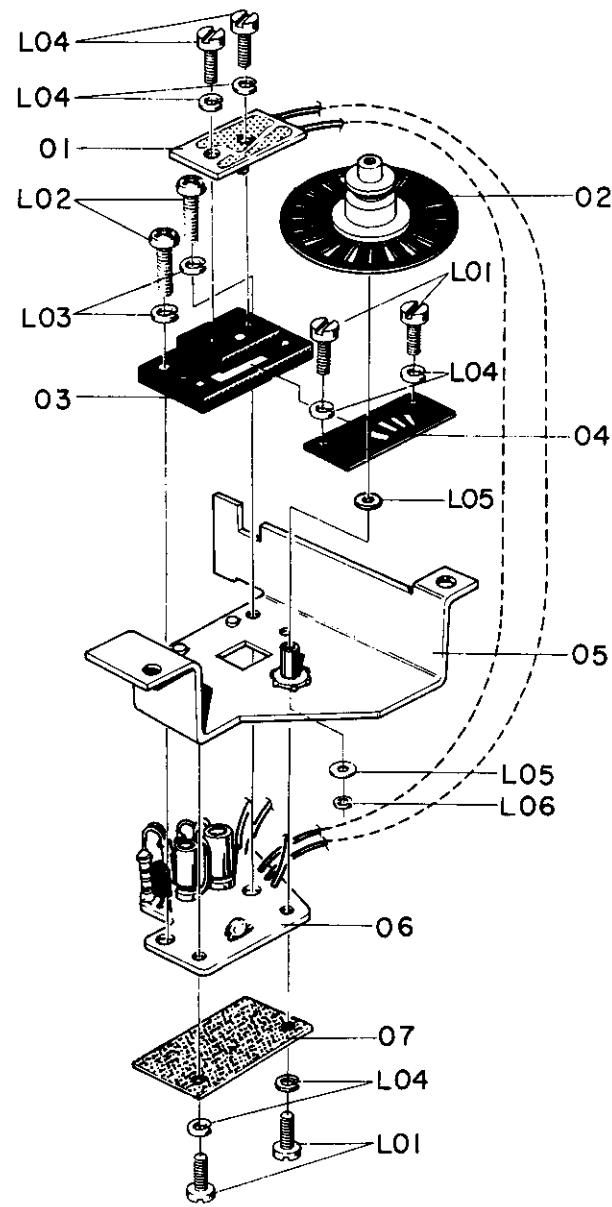

Serial No. 3702551-
Fig. 10.7

10.8. Mount Base Cover Assembly (B04) (Previous Type)

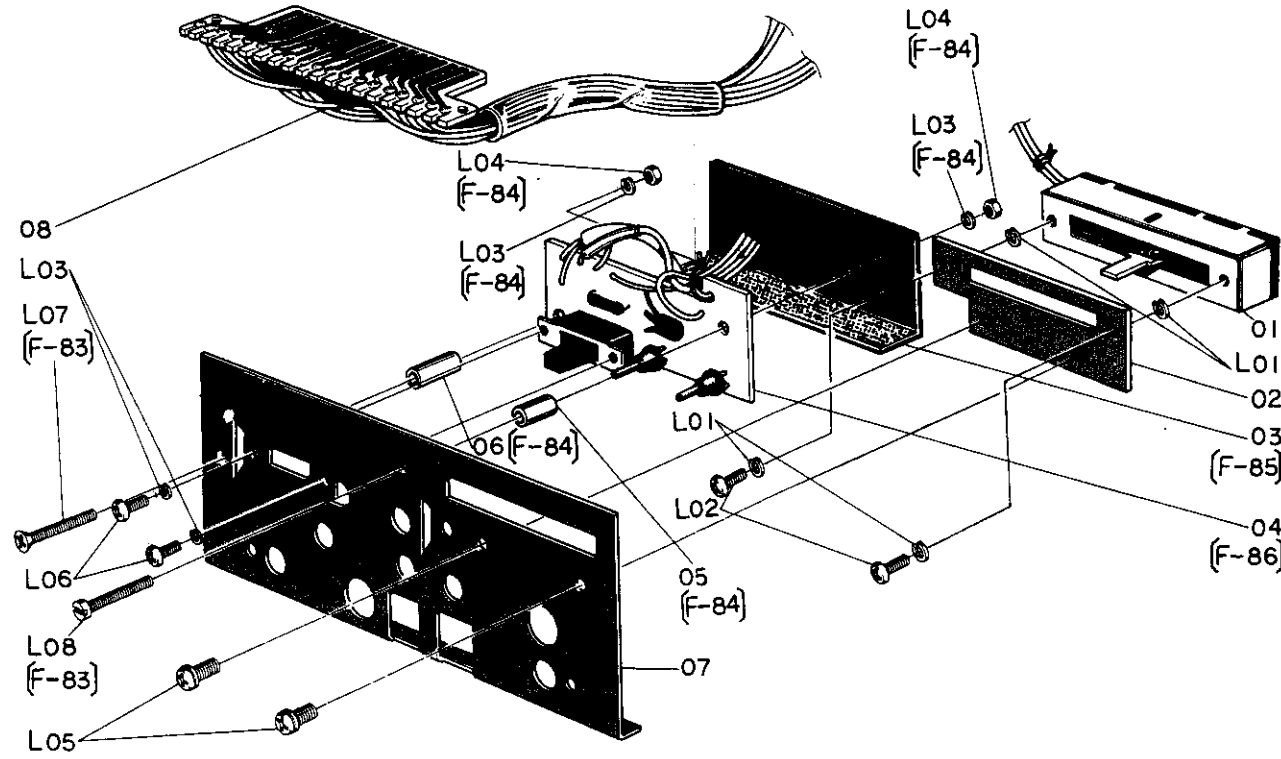

Serial No. 3703801-
Fig. 10.8

10.9. Meter Chassis Assembly (B05)

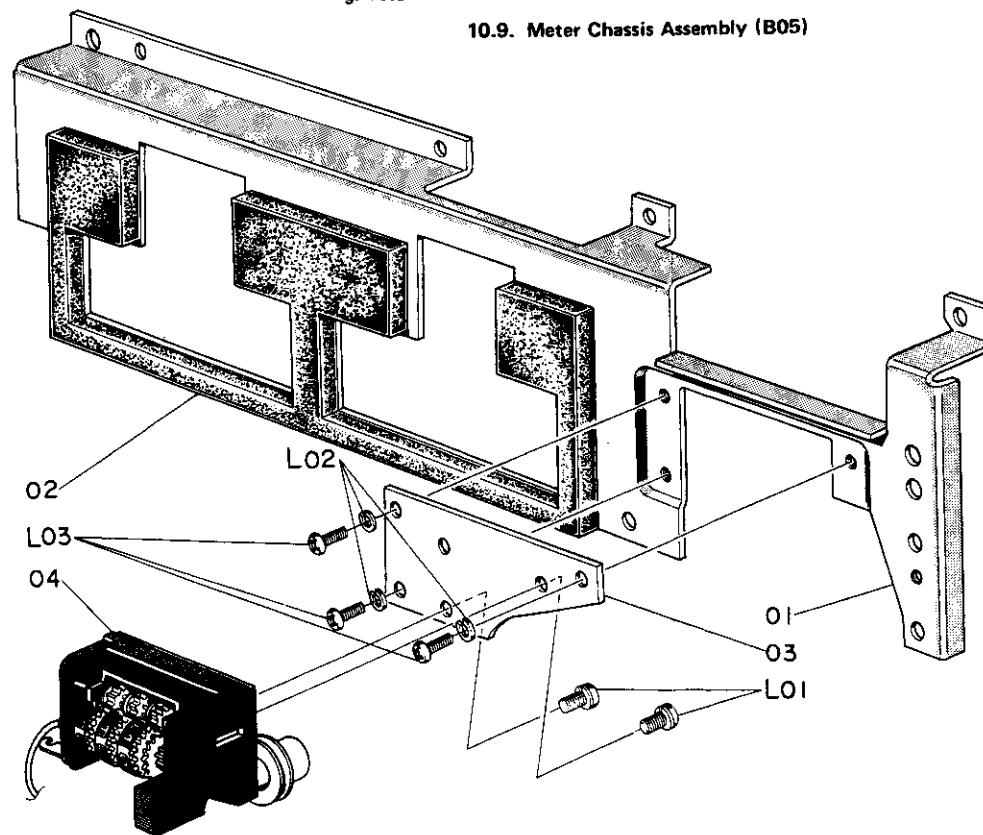
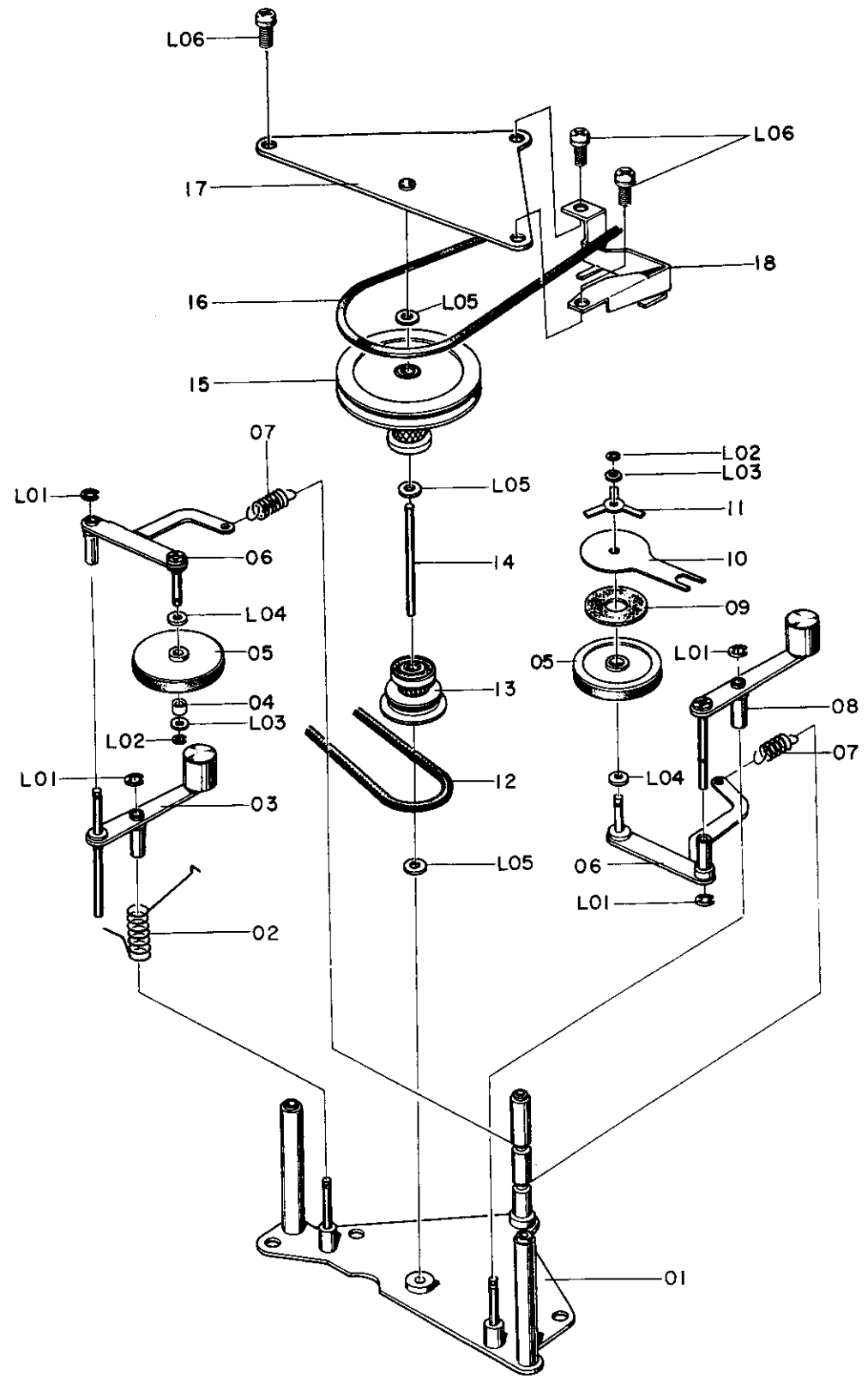

Fig. 10.9

Schematic Ref. No	Part No.	Description	Q'ty
B02	CA-5075	Head Mount Base Ass'y	1
01	C-5179	Pressure Arm Shaft Spring	2
02	C-5175	Pressure Arm Colour (B)	2
03	CA-5162	Pressure Roller Arm (C) Ass'y 700	1
04	C-5174	Pressure Arm Colour (A)	2
05	C-5477	Pressure Arm Shaft (C)	2
06	C-5191	Head Spring Shaft	2
07	C-5194	Head Spring	2
08	GA-101	Playback Head Ass'y P-52	1
09	GA-102	Record Head Ass'y R-52	1
10	C-5441	Head Mount Base (B)	1
11	C-5043	Head Adjust Spring	4
12	C-5346	Head Adjuster	1
13	B-7551	10P Plug Board	1
14	CA-5164	Pressure Roller Arm (C) Ass'y (S) 700	1
15	C-5193	Head Adjust Bush	1
16	C-5500	R.H. Adjust Bush	1
L01	E-222	E-Ring 2	2
L02	E-581	Washer 3 Spring	2
L03	C-5371	Mount Base Cover Stud	2
L04	E-629	Screw M2.6 x 8 Cup Point	2
L05	E-4	Screw M2 x 8 Cylinder Head	1
L06	E-29	Washer 2	4
B03	CA-5137	Auto Shut-off Ass'y	1
01	BA-3663	Shut-off L.E.D Board Ass'y	1
02	CA-5156	Shut-off Blade Ass'y	1
03	C-5461	Shut-off Holder	1
04	C-5467	Shut-off Shutter	1
05	CA-5138	Shut-off Base Ass'y	1
06	BA-3664	Shut-off Photo Board Ass'y	1
07	C-5476	Photo Board Cover	1
L01	E-166	Screw M2 x 4 Clinder Head	6
L02	E-121	Screw M2.6 x 6 Philips Pan Head	2
L03	E-26	Washer 2.6 Spring	2
L04	E-25	Washer 2 Spring	6
L05	C-3613	Washer 1.6 Mylar	2
L06	E-165	E-Ring 1.2	1
B04	CA-5115	Mount Base Cover Ass'y	1
01	B-7041	Slide Volume 500 (B)	1
02	C-5482	Volume Hold Plate	1
03	B-8105	Shield Plate	1
04	BA-3678	400Hz OSC. Switch P.C.B. Ass'y 700	1
05	J-3204	OSC. P.C.B. Stud	1
06	J-3251	OSC. P.C.B. Stud (B)	1
07	C-5481	Mount Base Cover (B)	1
08	B-1798	19P Plug P.C.B.	1
L01	E-26	Washer 2.6 Spring	4
L02	E-219	Screw M2.6x5 Philips Pan Head	2
L03	E-25	Washer 2 Spring	4
L04	E-176	Nut Hex M2	2
L05	E-622	Screw M3x5 Philips Pan Head (2A)	2
L06	E-124	Screw M2x4 Philips Pan Head	2
L07	E-663	Screw M2x15 Flat Head	1
L08	E-642	Screw M2x15 Cylinder Head	1
B05	CA-5149	Meter Chassis Ass'y	1
01	J-3192	Meter Chassis	1
02	J-3194	Meter Cushion	1
03	J-3193	Counter Holder	1
04	CA-5097	Tape Counter Ass'y	1
L01	E-612	Screw M3x5 Philips Pan Head (2A)	2
L02	E-26	Washer 2.6 Spring	3
L03	E-219	Screw M2.6x5 Philips Pan Head	3

10.11. Reel Drive Mechanism Assembly (B07)



Serial No. 3704501-
Fig. 10.10

10.10. Cassette Well Assembly (B08)

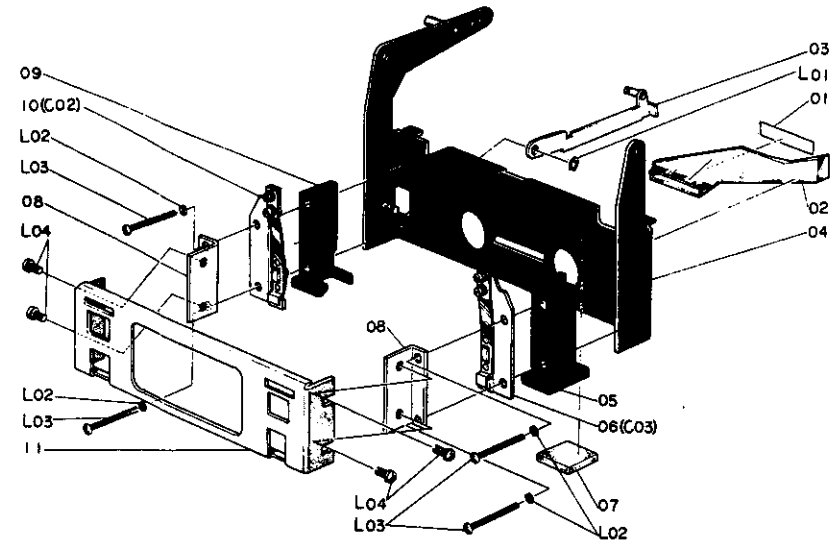

Fig. 10.11

10.12. Brake Arm Assembly (B08)

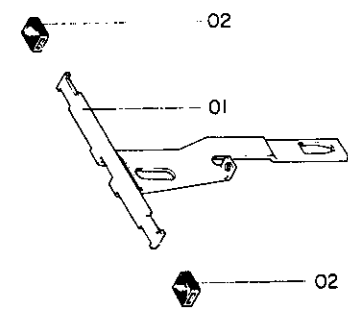
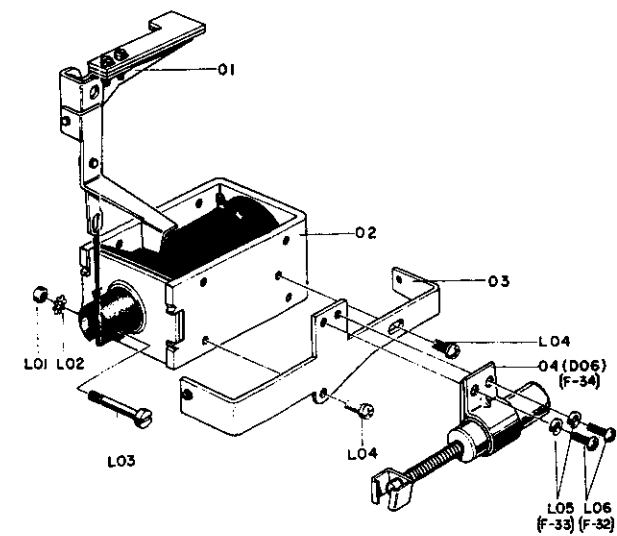

Fig. 10.12

10.13. Head Base Solenoid Assembly (B09)



Serial No. 3702551-
Fig. 10.13

Schematic Ref. No.	Part No.	Description	
B07	CA-5152	Reel Drive Mechanism Ass'y	1
01	CA-5021	Center Pulley Ass'y	1
02	C-5043	Idler Spring	1
03	CA-5017	Idler Arm B Ass'y (T)	1
04	C-5442	Idler Colour	1
05	C-5010	Idler Pulley Ass'y	21
06	CA-5015	Idler Arm (A) Ass'y	2
07	C-5281	Idler Arm Spring (B)	2
08	CA-5151	Idler Arm Ass'y (F)	1
09	C-5055	Idler Felt	1
10	C-5064	Idler Friction Plate	1
11	C-5066	Idler Friction Spring	1
12	C-5080	Fast Wind Belt	1
13	CA-5128	Fast Wind pulley (C) Ass'y	1
14	C-5073	Center Shaft	1
15	CA-5129	Center Drive Pulley (C) Ass'y	1
16	C-5081	Center Belt	1
17	CA-5022	Center Pulley (B) Ass'y	1
18	C-5480	Idler Arm Stopper	1
L01	E-42	E-Ring 1.5	4
L02	E-165	E-Ring 1.2	2
L03	C-3813	Washer 1.6 Mylar	2
L04	C-5065	Idler Metal Washer	2
L05	C-3174	Washer 2.1 Mylar	3
L06	E-612	Screw M3 x 6 Philips Pan Head (2A)	3
B06	CA-5148	Cassette Well Ass'y	1
01	M-3403	Illumination Tape	1
02	H-3255	Tape Illumination Lens	1
03	CA-5055	Well Stopper Ass'y	1
04	CA-5098	Cassette Well Sub Ass'y	1
05	C-5375	Cassette Case R	1
06	CA-5095	Cassette Spring Ass'y R	1
07	C-5378	Cassette Rubber	1
08	C-5336	Lid Holder Plate R	2
09	C-5374	Cassette Case L	1
10	CA-5096	Cassette Spring Ass'y L	1
11	C-5338	Lid Holder	1
L01	E-222	E-Ring 2	1
L02	E-26	Washer 2.6 Spring	4
L03	E-251	Screw M2.6x18 Philips Pan Head	4
L04	E-622	Screw M3x5 Philips Pan Head	4
B08	CA-5023	Brake Arm Ass'y	1
01	C-5082	Brake Arm	1
02	C-5083	Brake Shoe	2
B09	CA-5145	Head Base Solenoid Ass'y	1
01	CA-5027	Base Look Arm Ass'y	1
02	C-5099	Head Base Solenoid	1
03	CA-5041	Base Damper Holder Ass'y	1
04	CA-5133	Base Damper Ass'y	1
L01	E-507	Nut M3 Hex	1
L02	E-172	Washer 3 Toothed	1
L03	C-5098	Solenoid Bolt	1
L04	E-612	Screw M3 x 6 Philips Pan Head (2A)	2
L05	E-26	Washer 2.6 Spring	2
L06	E-220	Screw M2.6 x 8 Philips Pan Head	2

10.14. Brake Solenoid Assembly (B10)

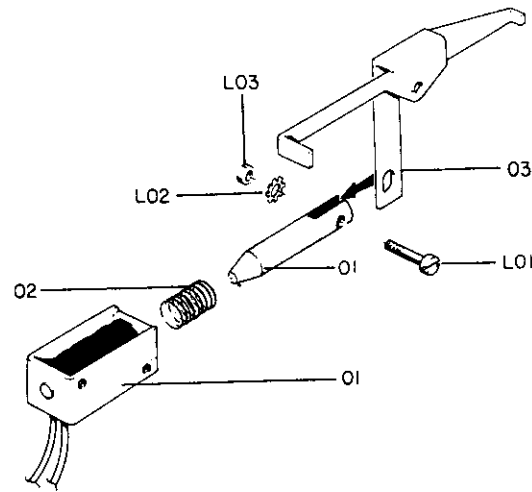
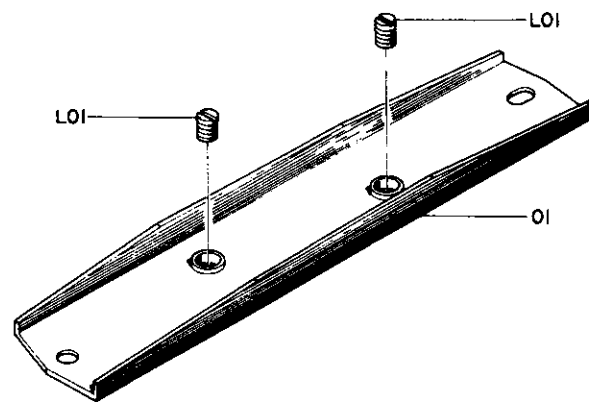

Fig. 10.14

10.15. Flywheel Holder Assembly (B11)



Serial No. 3702551-
Fig. 10.15

10.16. Take-Up Pulley Assembly (B12)

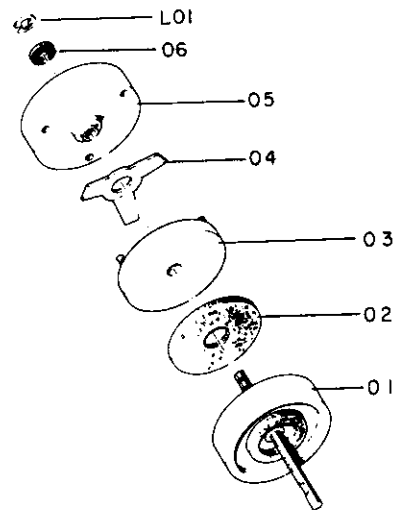

Serial No. 3702551-
Fig. 10.16

10.17. Motor Cap Assembly (B13)

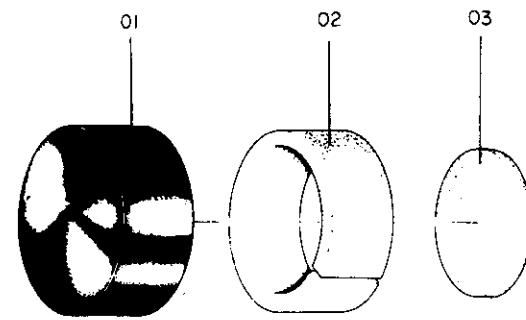

Fig. 10.17

10.18. Base Switch Assembly (B14)

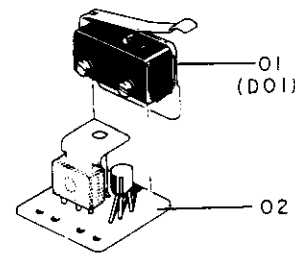

Fig. 10.18

10.19. Sub Motor Assembly (B15)

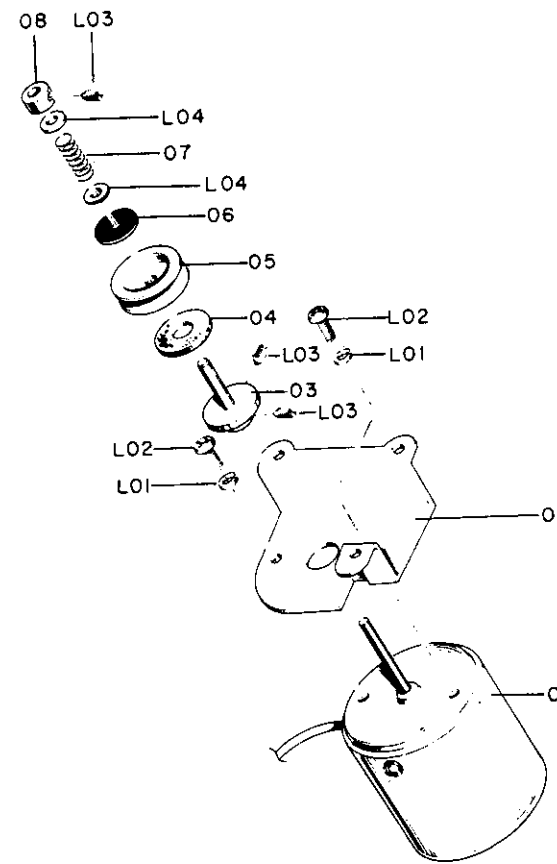
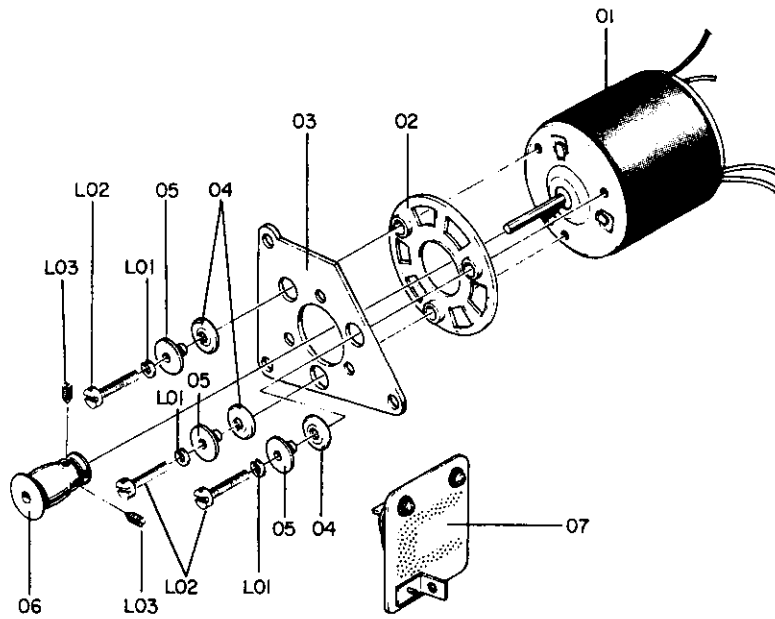

Fig. 10.19

Schematic Ref. No.	Part No.	Description	Qty
B10	CA-5053	Brake Solenoid Ass'y	1
01	C-5086	Brake Solenoide	1
02	C-5087	Brake Solenoide Spring	1
03	C-5085	Brake Linkage	1
L01	C-5419	Brake Bolt	1
L02	E-233	Washer 2.6 Toothed	1
L03	E-21	Nut Hex M2.6	1
B11	CA-5171	Flywheel Holder Ass'y	1
01	CA-5008	Flywheel Holder Sub Ass'y	1
L01	C-5494	Thrust Screw	2
B12	CA-5130	Take-up Pulley Ass'y	1
01	CA-5131	Supply Pulley Ass'y	1
02	C-5040	Take-up Felt	1
03	C-5037	Friction Pulley	1
04	C-5036	Take-up Spring	1
05	C-5034	Take-up Pulley B	1
06	C-5035	Take-up Thrust Plate	1
L01	E-42	E-Ring 1.2	1
B13	CA-5158	Motor Cap Ass'y	1
01	C-3796	Motor Cup	1
02	C-3794	Motor Cover A	1
03	C-3795	Motor Cover B	1
B14	CA-5132	Base Switch Ass'y (A)	1
01	CA-5025	Base SW Sub-Ass'y	1
02	BA-3666	Base SW P.C.B. Ass'y	1
B15	CA-5030	Sub-Motor Ass'y	1
01	C-5105	MSR-5SB-2N Motor	1
02	C-5107	Sub-Motor Holder	1
03	C-5239	Motor Friction Pulley	1
04	C-5055	Idler Felt	1
05	C-5238	Sub-Motor Pulley	1
06	AM-6178	W4-12-0.5F	1
07	C-5241	Motor Friction Spring	1
08	C-5240	Motor Friction Collar	1
L01	E-26	Washer 2.6 Spring	2
L02	E-120	Screw M2.6 x 3 Philips Pan Head	2
L03	E-626	Screw M2 x 3 Cup Point	3
L04	AM-6242	W3-6-0.2F	2

10.20. Main Motor Assembly (B16)



Serial No. 3705511-
Fig. 10.20

10.21. Eject Damper Bracket Assembly (B17)

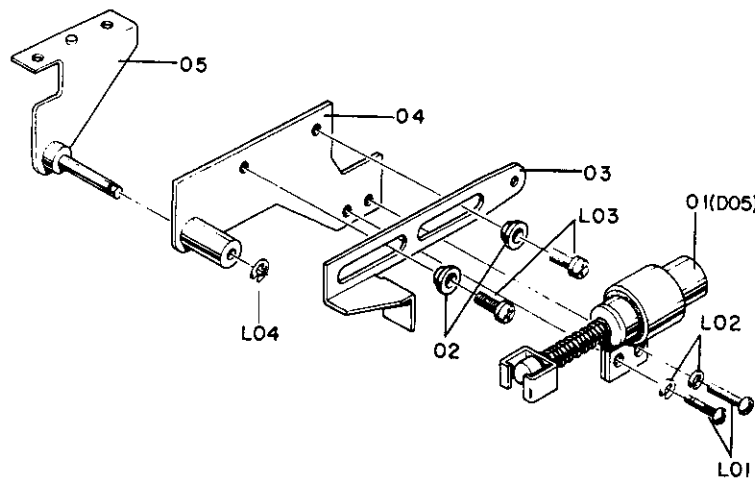

Serial No. 3703801-
Fig. 10.21

10.22. Cassette Holder Assembly (B18)

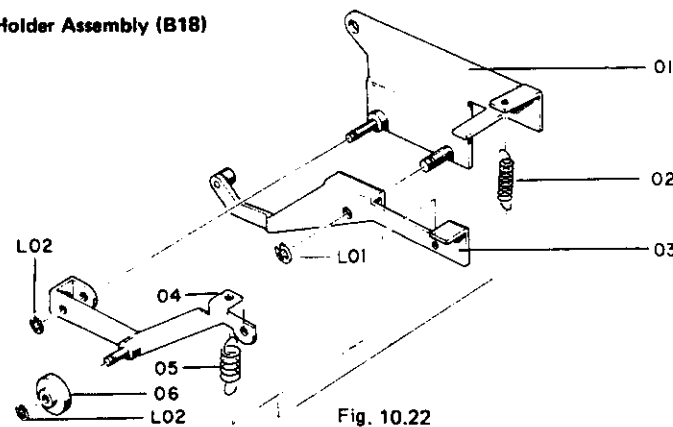

Fig. 10.22

10.23. Memory Switch Assembly (B19)

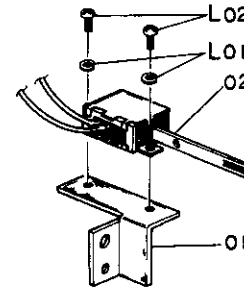
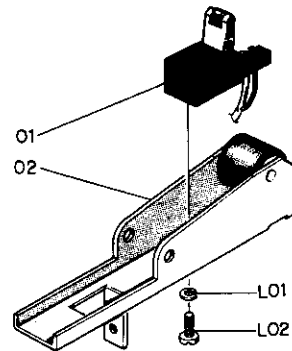

Fig. 10.23

10.24. Pressure Roller Arm (C) Assembly (S) 700 (C01)



Serial No. 3706201-
Fig. 10.24

10.25. Cassette Spring Assembly L (C02)

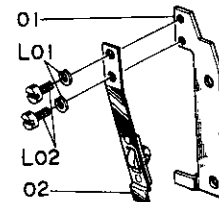

Fig. 10.25

10.26. Cassette Spring Assembly R (C03)

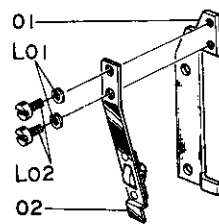

Fig. 10.26

10.27. Base Switch Assembly (C04)

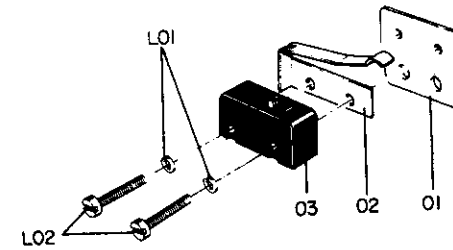
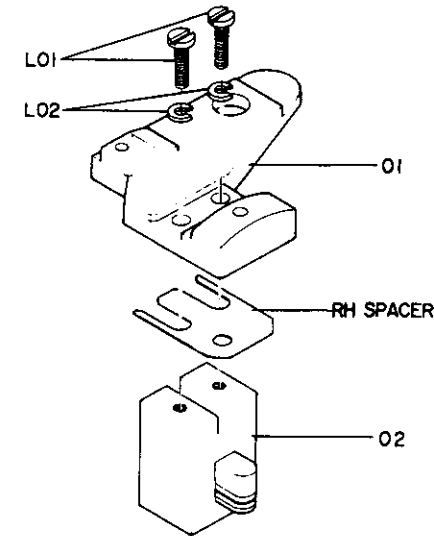

Fig. 10.27

10.28. Rec. Head Assembly (C05) (Previous Type)



Serial No. until 3709322
Fig. 10.28

10.29. P.B. Head Assembly (C06) (Previous Type)

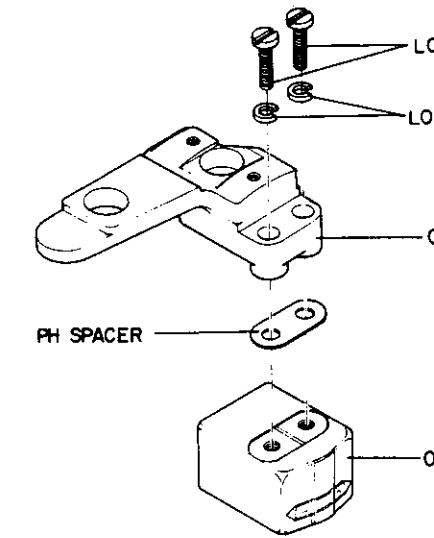

Serial No. until 3709322
Fig. 10.29

Schematic Ref. No.	Part No.	Description	Qty
B16	CA-5154	Main Motor Ass'y	1
01	C-5515	NSM-2 Motor	1
02	C-5509	Floating Sheet	1
03	C-5198	Motor Plate	1
04	C-5510	Floating Bush	3
05	C-5508	Bush Collar	3
06	C-5499	Motor Pulley (C)	1
07	BA-3662	Motor Governor Ass'y	1
L01	E-25	Washer 2 Spring	3
L02	E-4	Screw M2 x 8 Cylinder Head	3
L03	E-626	Screw M2 x 3 Cup Point	2
B17	CA-5134	Eject Damper Bracket Ass'y	1
01	CA-5047	Eject Damper Ass'y	1
02	C-5135	Center Guide	2
03	C-5232	Eject Damper Linkage	1
04	CA-5068	Damper Plate Ass'y	1
05	CA-5046	Damper Plate Holder Ass'y	1
L01	E-220	Screw M2.6 x 8 Philips Pan Head	2
L02	E-26	Washer 2.6 Spring	2
L03	E-612	Screw M3 x 6 Philips Pan Head	-2
L04	E-53	E-Ring 2.3	1
B18	CA-5044	Cassette Holder Ass'y	1
01	CA-5058	Cassette Hold Plate Ass'y	1
02	C-5244	Linkage Spring	1
03	CA-5059	Cassette Arm A Ass'y	1
04	CA-5080	Cassette Arm B Ass'y	1
05	C-5245	Hold Spring	1
06	C-5217	Hold Roller	1
L01	E-222	E-Ring 2	1
L02	E-42	E-Ring 1.5	2
B19	BA-3680	Memory Switch Ass'y	1
01	J-3219	Memory Switch Holder (B)	1
02	B-7034	Memory Switch (B)	1
L01	E-25	Washer 2 Spring	2
L02	E-226	Screw M2x4 Philips Pan Head	2
C01	CA-5164	Pressure Roller Arm (C) Ass'y (S) 700	1
01	G8	Erase Head	1
02	CA-5162	Pressure Roller Arm (C) Ass'y (S)	1
L01	E-25	Washer 2 Spring	1
L02	E-185	Screw M2 x 6 Cylinder Head	1
C02	CA-5096	Cassette Spring Ass'y L	1
01	C-5486	Cassette Spring Holder L	1
02	CA-5153	Cassette Spring Ass'y	1
L01	E-25	Washer 2 Spring	2
L02	E-2	Screw M2x3 Cylinder Head	2
C03	CA-5095	Cassette Spring Ass'y R	1
01	C-5487	Cassette Spring Holder R	1
02	CA-5153	Cassette Spring Ass'y	1
L01	E-25	Washer 2 Spring	2
L02	E-2	Screw M2x3 Cylinder Head	2
C04	CA-5025	Base Switch Sub Ass'y	1
01	C-5091	Base Switch Holder	1
02	C-5092	Switch Spring (A)	1
03	MT-210157	Micro Switch (SS-5)	1
L01	E-25	Washer 2 Spring	2
L02	E-218	Screw M2 x 10 Cylinder Head	2

Schematic Ref. No.	Part No.	Description	Q'ty
C05	GA-102	R-52 Record Head Ass'y	
01	AH-1083	RH Plate	1
02	GA-2007	R-52 Record Head	1
L01	E-185	Screw M2x6 Cylinder Head	2
L02	E-25	Washer 2 Spring	2
	AH-1120	RH Spacer t=0.1mm	
	AH-1121	RH Spacer t=0.15mm	
	AH-1122	RH Spacer t=0.2mm	
	AH-1123	RH Spacer t=0.25mm	
	AH-1124	RH Spacer t=0.3mm	
C06	GA-101	P-52 Playback Head Ass'y	
01	AH-1082	PH Plate	1
02	GA-2006	P-52 Playback Head	1
L01	E-675	Screw M2x7 Cylinder Head	2
L02	E-25	Washer 2 Spring	2
	AH-1115	PH Spacer t=0.1mm	
	AH-1116	PH Spacer t=0.15mm	
	AH-1117	PH Spacer t=0.2mm	
	AH-1118	PH Spacer t=0.25mm	
	AH-1119	PH Spacer t=0.3mm	

10.30. Head Mount Base Block (D01) (New Type)

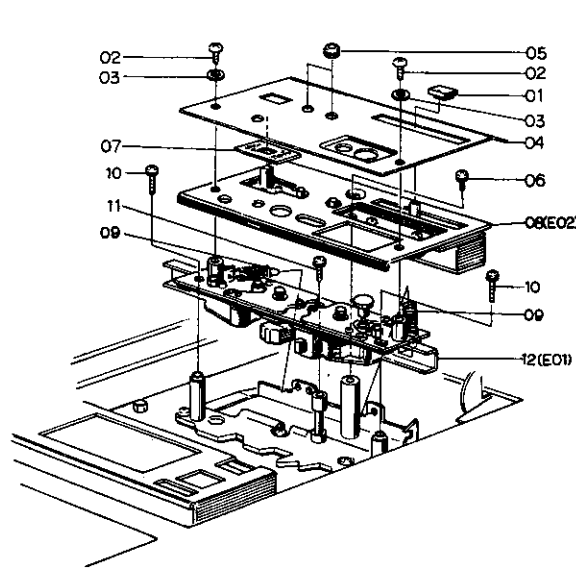

Serial No. 3709323-
Fig. 10.30

10.31. Head Mount Base (E) Ass'y (E01) (New Type)

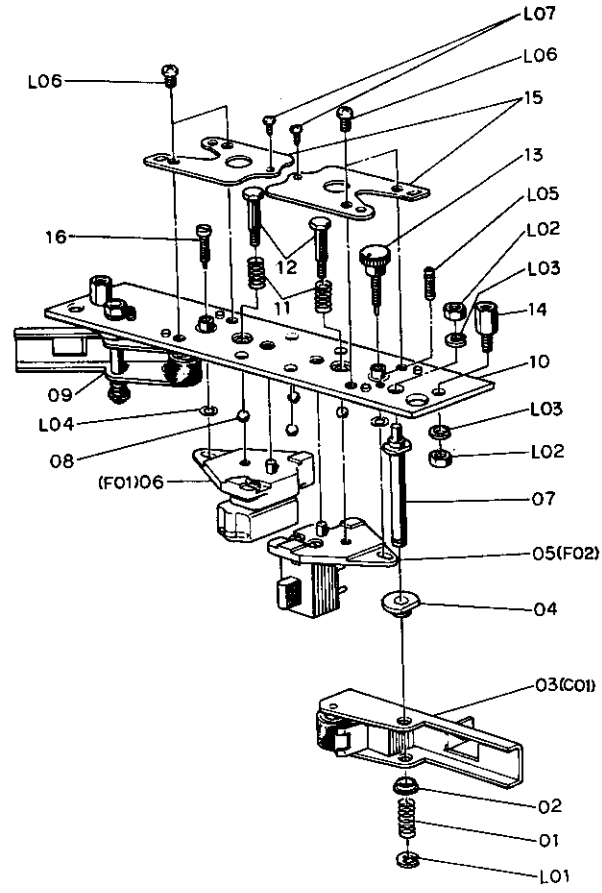

Serial No. 3709323-
Fig. 10.31

Schematic Ref. No.	Part No.	Description	Q'ty
D01		Head Mount Base Block (New Type)	
01	H-3254	Pitch Control Knob	1
02	E-656	Screw M3 x 4 Truss Head Bronze	2
03	E-624	Washer 3 Collar	2
04	M-3562	Mount Base Name Plate B	1
05	C-5376	L.E.D. Escutcheon	2
06	E-622	Screw M3 x 5 Philips Pan Head (2A)	1
07	J-3213	Test Tone Switch Felt	1
08	CA-5201	Mount Base Cover B Ass'y	1
09	C-5178	Pressure Arm Spring	2
10	E-624	Screw M3 x 10 Philips Pan Head (2A)	2
11	E-510	Screw M3 x 8 Philips Pan Head (2A)	1
12	CA-5168	Head Mount Base (E) Ass'y	1
E01	CA-5168	Head Mount Base (E) Ass'y	1
01	C5179	Pressure Arm Shaft Spring	2
02	C-5175	Pressure Arm Collar (B)	2
03	CA-5164	Pressure Roller Arm (C) Ass'y (S) 700	1
04	C-5174	Pressure Arm Collar (A)	2
05	CA-5174	Record Head Ass'y (A)	1
06	CA-5173	Playback Head Ass'y (A)	1
07	C-5477	Pressure Arm Shaft (C)	2
08	C-3595	3mm Steel Ball	4
09	CA-5162	Pressure Roller Arm (C) Ass'y 700	1
10	CA-5169	Head Mount Base (F) Ass'y	1
11	C-5555	Head Spring (B)	2
12	C-5559	Head Spring Shaft (A)	2
13	C-5562	R.H. Azimuth Screw 700	1
14	C-5565	Plate Stud (A)	2
15	C-5556	Head Pressure Plate	2
16	C-5558	P.H. Azimuth Screw	1
-	B-7551	10P Plug Board	1
L01	E-222	E-Ring 2	2
L02	E-507	Nut Hex M3	4
L03	E-581	Washer 3 Spring	4
L04	C-5567	Washer 1	2
L05	E-629	Screw M2.6x8 Cup Point	2
L06	E-120	Screw M2.6x3 Philips Pan Head	4
L07	E-692	Screw M2x2.5 Philips Pan Head (JCIS)	2
E02	CA-5201	Mount Base Cover (B) Ass'y	1
01	B-7041	Slide Volume 500 (B)	1
02	C-5482	Volume Hold Plate	1
03	B-8105	Shield Plate	1
04	BA-3678	400Hz OSC Switch P.C.B. Assy 700	1
05	J-3204	OSC P.C.B. Stud	1
06	J-3251	OSC P.C.B. Stud (B)	1
07	C-5563	Mount Base Cover (C)	1
08	B-1798	19P Plug P.C.B.	1
L01	E-26	Washer 2.6 Spring	4
L02	E-219	Screw M2.6 x 5 Philips Pan Head	2
L03	E-25	Washer 2 Spring	4
L04	E-176	Nut Hex M2	2
L05	E-622	Screw M3 x 5 Philips Pan Head (2A)	2
L06	E-124	Screw M2 x 4 Philips Pan Head	2
L07	E-663	Screw M2 x 15 Flat Head	1
L08	E-642	Screw M2 x 15 Cylinder Head	1
F01	CA-5173	Playback Head Ass'y (A)	1
01	GA-2006	P-52 Playback Head	1
02	GA-1017	P.H. Plate (A) Ass'y	1
L01	E-4	Screw M2x8 Cylinder Head	2
F02	CA-5174	Record Head Ass'y (A)	1
01	GA-2007	R-52 Record Head	1
02	GA-1018	R.H. Plate (A) Ass'y	1
L01	E-166	Screw M2x4 Cylinder Head	2

10.32. Mount Base Cover (B) Ass'y (E02) (New Type)

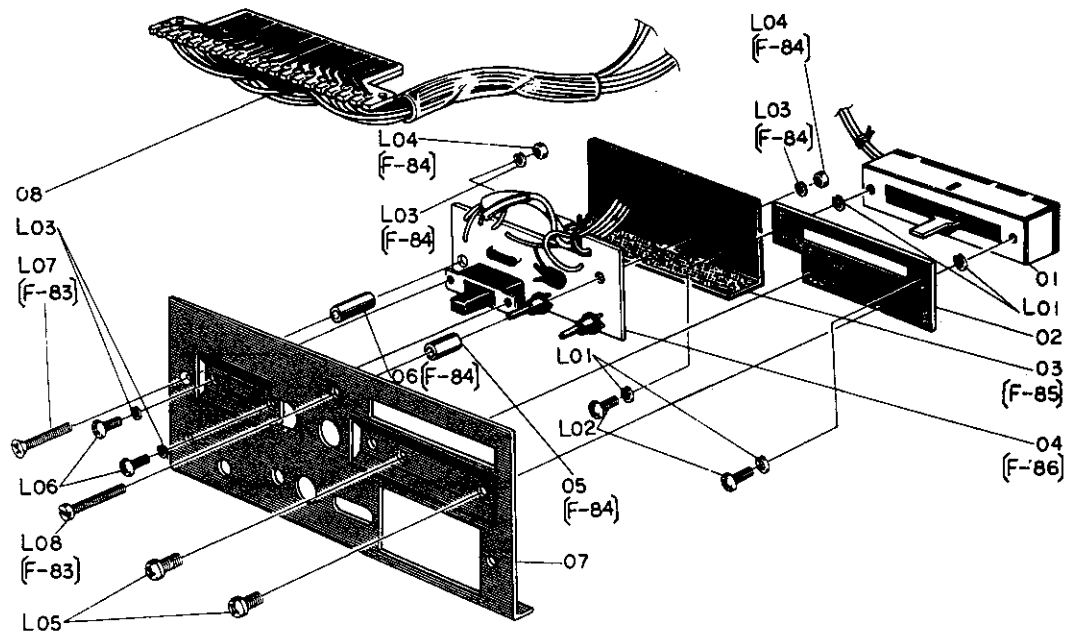

Serial No. 3709323-
Fig. 10.32

10.33. Playback Head Ass'y (F01) (New Type)

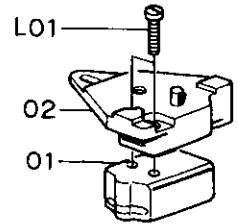

Serial No. 3709323-
Fig. 10.33

10.34. Record Head Ass'y (F02) (New Type)

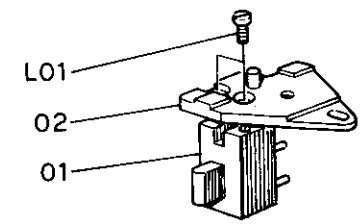

Serial No. 3709323-
Fig. 10.34

11. MOUNTING DIAGRAM / PARTS LIST

11.1. Main P.C.B.

Note 1: Where serial numbers are shown underneath the modified assembly, the modifications apply to those serial numbers only. But if no serial numbers, then no modifications have been made from the initial production.
 Note 2: Mounting Diagram shows a dip side view of the P.C.B.

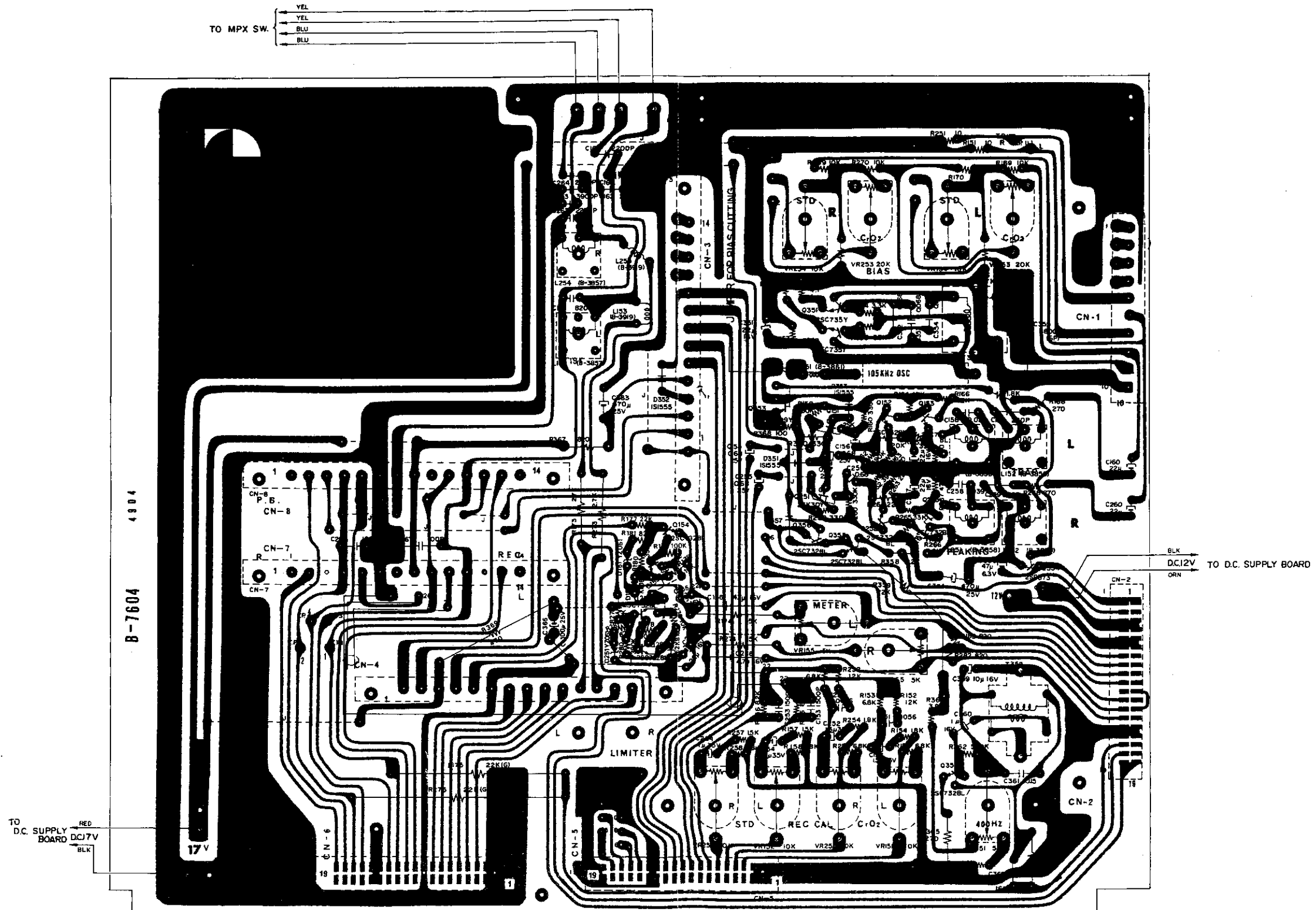

Serial No. 3707221-

Fig. 11.1

11.2. P.B. Dolby P.C.B.

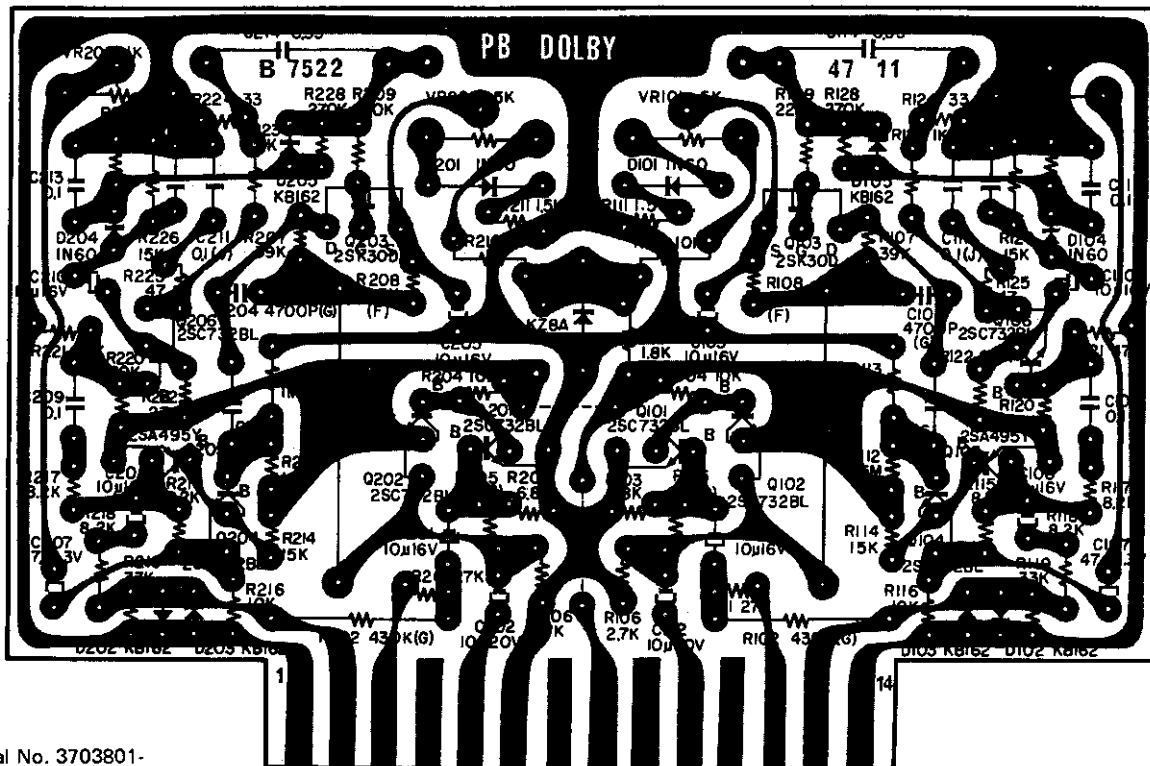

Serial No. 3703801-
Fig. 11.2

Schematic Ref. No.	Part No.	Description	Schematic Ref. No.	Part No.	Description
	BA-3588 P.B. Dolby P.C.B. Ass'y				
Q101,201	B-6005	Transistor 2SC732(BL)	R117,217	B-1878	Carbon Resistor 8.2K ELR $\frac{1}{4}$ J
102,202			118,218		
104,204			R119,219	B-1879	Carbon Resistor 33K ELR $\frac{1}{4}$ J
106,206			R120,220	B-5568	Carbon Resistor 120K ELR $\frac{1}{4}$ J
Q103,203	B-6001	FET 2SA495(Y)	R121,221	B-5562	Carbon Resistor 47K ELR $\frac{1}{4}$ J
Q105,205	B-6006	Transistor 2SA495(Y)	R123,223	B-1781	Carbon Resistor 1K ELR $\frac{1}{4}$ J
D1	B-1808	Zener Diode KZ8A	R124,224	B-5567	Carbon Resistor 33 ELR $\frac{1}{4}$ J
D101,201	B-30P	Germanium Diode 1N60(P)	R125,225	B-5569	Carbon Resistor 47 ELR $\frac{1}{4}$ J
104,204			R127,227	B-5600	Carbon Resistor 270K ELR $\frac{1}{4}$ J
D102,202	B-1599	Silicon Diode KB162	128,228		
103,203			C101,201	B-1412	Electrolytic Capacitor 10 μ 16V
105,205			105,205		
R1	B-1830	Carbon Resistor 1.8K ELR $\frac{1}{4}$ J	108,208		
R101,201	B-5538	Carbon Resistor 27K ELR $\frac{1}{4}$ J	110,210		
R102,202	B-5536	Carbon Resistor 430K RD $\frac{1}{4}$ G	C102,202	B-5581	Tantalum Capacitor 10 μ 20V M
R103,203	B-1877	Carbon Resistor 6.8K ELR $\frac{1}{4}$ J	C103,203	B-1786	P.P Capacitor 0.033 μ 50V G
R104,204	B-1833	Carbon Resistor 10K ELR $\frac{1}{4}$ J	C104,204	B-1608	P.P Capacitor 4700P 50V G
110,210			C106,206	B-1603	Mylar Capacitor 0.1 μ 50V K
116,216			109,209		
R105,205	B-5535	Carbon Resistor 68K RD $\frac{1}{4}$ G	113,213		
R106,206	B-1782	Carbon Resistor 2.7K ELR $\frac{1}{4}$ J	C107,207	B-1404	Electrolytic Capacitor 47 μ 6.3V
122,222			C111,211	B-1780	Mylar Capacitor 0.1 μ 50V J
R107,207	B-1885	Carbon Resistor 39K ELR $\frac{1}{4}$ J	C112,212	B-91	Mylar Capacitor 1000P 50V M
R108,208	B-1585	Carbon Resistor 3.3K RD $\frac{1}{4}$ F	C114,214	B-1602	Mylar Capacitor 0.33 μ 50V K
R109,209	B-5596	Carbon Resistor 220K ELR $\frac{1}{4}$ J	VR101,201	B-1470	Semi-fixed Volume 5K
R111,211	B-5505	Carbon Resistor 1.5K ELR $\frac{1}{4}$ J	VR102,202	B-1428	Semi-fixed Volume 1K
R112,212	B-5601	Carbon Resistor 1.5M ELR $\frac{1}{4}$ J	B-3924	Gate Pin	
R113,213	B-5564	Carbon Resistor 1M ELR $\frac{1}{4}$ J	M-3345	P.B. Dolby Indication Label	
R114,214	B-5591	Carbon Resistor 15K ELR $\frac{1}{4}$ J	B-7522	P.B. Dolby P.C.B.	
126,226					
R115,215	B-1878	Carbon Resistor 8.2K ELR $\frac{1}{4}$ J			

11.3. Rec. Dolby P.C.B.

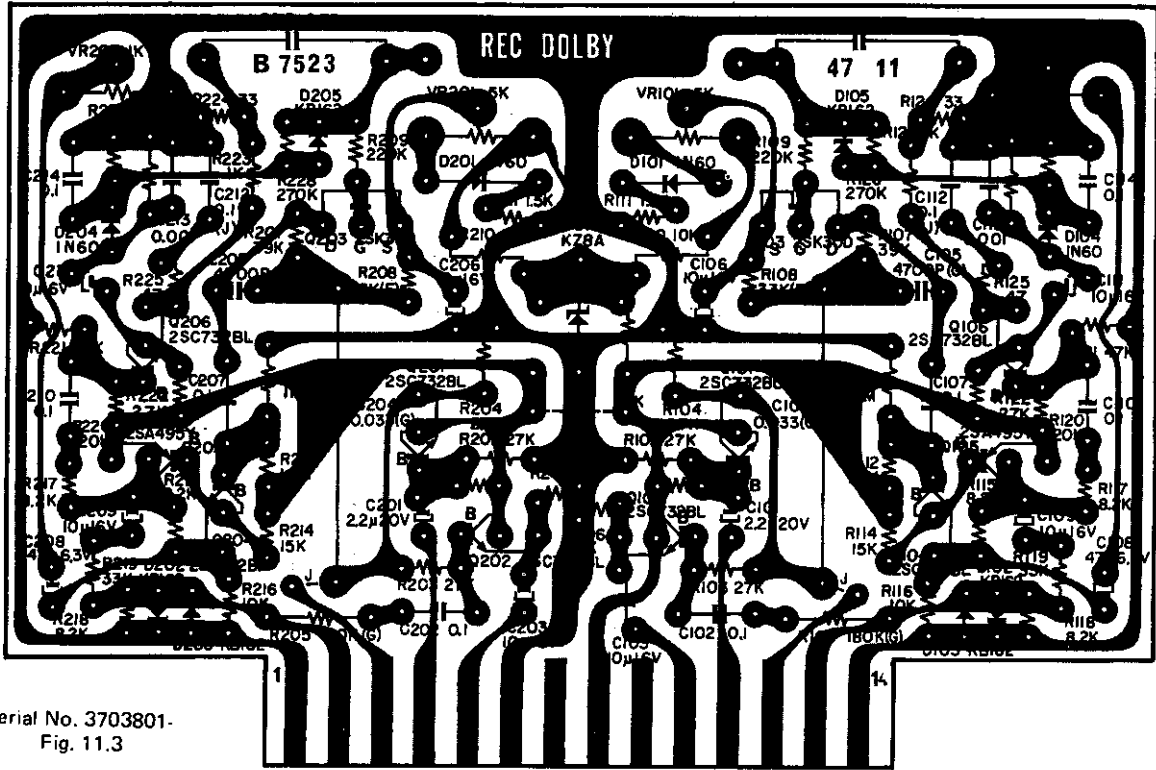

Serial No. 3703801-
Fig. 11.3

Schematic Ref. No.	Part No.	Description	Schematic Ref.No.	Part No.	Description
	BA-3589	REC. Dolby P.C.B. Ass'y	R117,217	B-1878	Carbon Resistor 8.2K ELR $\frac{1}{4}$ J
			118,218		
			R119,219	B-1879	Carbon Resistor 33K ELR $\frac{1}{4}$ J
Q101,201	B-6005	Transistor 2SC732(BL)	R120,220	B-5568	Carbon Resistor 120K ELR $\frac{1}{4}$ J
102,202			R121,221	B-5562	Carbon Resistor 47K ELR $\frac{1}{4}$ J
104,204			R123,223	B-1781	Carbon Resistor 1K ELR $\frac{1}{4}$ J
106,206			R124,224	B-5567	Carbon Resistor 33 ELR $\frac{1}{4}$ J
Q103,203	B-6001	FET 2SK30A(D)	R125,225	B-5569	Carbon Resistor 47 ELR $\frac{1}{4}$ J
Q105,205	B-6006	Transistor 2SA495(Y)	R127,227	B-5600	Carbon Resistor 270K ELR $\frac{1}{4}$ J
D1	B-1808	Zener Diode KZ8A	128,228		
D101,201	B-30P	Germanium Diode IN60(P)	C101,201	B-5598	Tantalum Capacitor 2.2 μ 20V
104,204			C102,202	B-1603	Mylar Capacitor 0.1 μ 50V K
D102,202	B-1599	Silicon Diode KB162	107,207		
103,203			110,210		
105,205			114,214		
R1	B-1830	Carbon Resistor 1.8K ELR $\frac{1}{4}$ J	114,214		
R101,201	B-5661	Carbon Resistor 22K ELR $\frac{1}{4}$ J	C103,203	B-1412	Electrolytic Capacitor 10 μ 16V
R102,202	B-5538	Carbon Resistor 27K ELR $\frac{1}{4}$ J	106,206		
103,203			109,209		
R104,204	B-1782	Carbon Resistor 2.7K ELR $\frac{1}{4}$ J	111,211		
122,222			C104,204	B-1786	P.P Capacitor 0.033 μ 50V G
R105,205	B-1590	Carbon Resistor 180K RD $\frac{1}{4}$ G	C105,205	B-1608	P.P Capacitor 4700P 50V G
R106,206	B-5591	Carbon Resistor 15K ELR $\frac{1}{4}$ J	C108,208	B-1404	Electrolytic Capacitor 47 μ 6.3V
114,214			C112,212	B-1780	Mylar Capacitor 0.1 μ 50V J
126,226			C113,213	B-91	Mylar Capacitor 0.001 μ 50V M
R107,207	B-1885	Carbon Resistor 39K ELR $\frac{1}{4}$ J	C115,215	B-1602	Mylar Capacitor 0.33 μ 50V K
R108,208	B-1585	Carbon Resistor 3.3K RD $\frac{1}{4}$ F	VR101,201	B-1470	Semi-fixed Volume 5K
R109,209	B-5596	Carbon Resistor 220K ELR $\frac{1}{4}$ J	VR102,202	B-1428	Semi-fixed Volume 1K
R110,210	B-1833	Carbon Resistor 10K ELR $\frac{1}{4}$ J	B-3924	Gate Pin	
116,216			M-3346	REC. Dolby Indication Label	
R111,211	B-5505	Carbon Resistor 1.5K ELR $\frac{1}{4}$ J	B-7523	REC. Dolby P.C.B.	
R112,212	B-5601	Carbon Resistor 1.5M ELR $\frac{1}{4}$ J			
R113,213	B-5564	Carbon Resistor 1M ELR $\frac{1}{4}$ J			
R115,215	B-1878	Carbon Resistor 8.2K ELR $\frac{1}{4}$ J			

X

11.4. P.B. Head Amp. P.C.B.

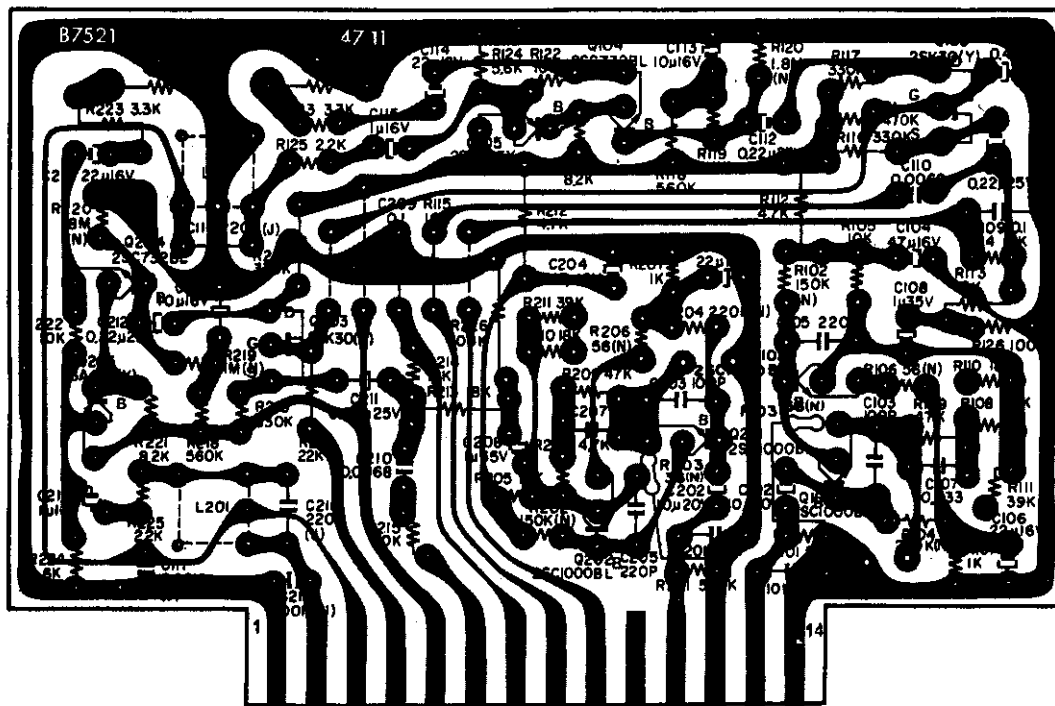

Serial No. 3703801-

Fig. 11.4

Schematic Ref. No.	Part No.	Description	Schematic Ref. No.	Part No.	Description
	BA-3651	P.B. Head AMP. P.C.B. Ass'y	R125,225	B-5566	Carbon Resistor 2.2K ELR $\frac{1}{4}$ J
Q101,201	B-6003	Transistor 2SC1000(BL)	R126,226	B-1920	Carbon Resistor 100K ELR $\frac{1}{4}$ J
102,202			C1	B-1376	Aluminium Capacitor 0.47 μ 25V M
Q103,203	B-1600	FET 2SK30 (Y)	C101,201	B-1456	Ceramic Capacitor 47P 50V M
Q104,204	B-6005	Transistor 2SC732(BL)	C102,202	B-5581	Tantalum Capacitor 10 μ 20V M
Q105,205	B-6006	Transistor 2SA495(Y)	C103,203	B-1288	Ceramic Capacitor 100P 50V M
L101,201	B-68S	Bias Trap Coil 10.5mH	C104,204	B-1403	Electrolytic Capacitor 47 μ 16V
R1	B-5700	Carbon Resistor 470K ELR $\frac{1}{4}$ J	C105,205	B-1289	Ceramic Capacitor 220P 50V M
R2	B-5661	Carbon Resistor 22K ELR $\frac{1}{4}$ J			
R101,201	B-5665	Carbon Resistor 560K ELR $\frac{1}{4}$ J	C106,206	B-1862	Electrolytic Capacitor 22 μ 16V
118,218			114,214		
R102,202	B-5521	Carbon Resistor 150K (N)ELR $\frac{1}{4}$ J	C107,207	B-5531	Mylar Capacitor 0.033 μ 50V K
R103,203	B-5642	Carbon Resistor 56 (N)ELR $\frac{1}{4}$ J	C108,208	B-5638	Tantalum Capacitor 1 μ 35V M
106,206			C109,209	B-1603	Mylar Capacitor 0.1 μ 50V K
R104,204	B-5517	Carbon Resistor 220K (N)ELR $\frac{1}{4}$ J	C110,210	B-5530	Mylar Capacitor 6800P 50V K
R105,205	B-1833	Carbon Resistor 10K ELR $\frac{1}{4}$ J	C111,211	B-1664	Aluminium Capacitor 0.22 μ 25V M
115,215			112,212		
122,222			C113,213	B-1412	Electrolytic Capacitor 10 μ 16V
R107,207	B-1781	Carbon Resistor 1K ELR $\frac{1}{4}$ J	C115,215	B-1405	Electrolytic Capacitor 1 μ 16V
R108,208	B-1795	Carbon Resistor 4.7K ELR $\frac{1}{4}$ J	C116,216	B-5532	S.P. Capacitor 220P 35V J
112,212			C117,217	B-1913	Mylar Capacitor 1800P 50V J
R109,209	B-5562	Carbon Resistor 47K ELR $\frac{1}{4}$ J	VR101,201	B-1922	Semi-fixed Volume 20K
R110,210	B-5561	Carbon Resistor 18K ELR $\frac{1}{4}$ J		M-3344	P.B. Head AMP. Indication Label
113,213				B-7521	P.B. Head AMP. P.C.B.
R111,211	B-1885	Carbon Resistor 39K ELR $\frac{1}{4}$ J		B-8084	P.B. Head Amp. Shield Plate
R114,214	B-5591	Carbon Resistor 15K ELR $\frac{1}{4}$ J		B-8085	P.B. Head Amp. Shield Plate Insulator
R116,216	B-1921	Carbon Resistor 330K ELR $\frac{1}{4}$ J			
117,217					
R119,219	B-5749	Carbon Resistor 1M(N)ELR $\frac{1}{4}$ J			
R120,220	B-5748	Carbon Resistor 1.8M(N)ELR $\frac{1}{4}$ J			
R121,221	B-1878	Carbon Resistor 8.2K ELR $\frac{1}{4}$ J			
R123,223	B-1793	Carbon Resistor 3.3K ELR $\frac{1}{4}$ J			
R124,224	B-5673	Carbon Resistor 5.6K ELR $\frac{1}{4}$ J			

Schematic Ref. No.	Part No.	Description	Schematic Ref. No.	Part No.	Description
BA-3701 Front Control A Ass'y			C705,805	B-5667	Tantalum Capacitor 10 μ 16V M
— MIC Amp.—			C707,807	B-5638	Tantalum Capacitor 1 μ 35V
Q701,702	B-6003	Transistor 2SC1000 (BL)	C708,808	B-1389	Electrolytic Capacitor 4.7 μ 16V
801,802			C709,809	B-1405	Electrolytic Capacitor 1 μ 16V
901,902			C710,810	B-1664	Aluminum Capacitor 0.22 μ 25V
VR701,801	B-7024	Volume 50K (A)x2	C711,811	B-1412	Electrolytic Capacitor 10 μ 16V
VR901	B-7026	Volume 50K (A)	706,806		
R701,801	B-5559	Carbon Resistor 680 ELR $\frac{1}{2}$ J	712,812		
901			C713,813	B-1394	Electrolytic Capacitor 220 μ 6.3V
R702,802	B-5561	Carbon Resistor 18K ELR $\frac{1}{2}$ J	C906	B-1272	Electrolytic Capacitor 100 μ 25V
902			— Buffer & Meter Amp. —		
R703,803	B-5651	Carbon Resistor 270 ELR $\frac{1}{2}$ J	Q707,807	B-6005	Transistor 2SC732 (BL)
903			710,810		
R704,804	B-5565	Carbon Resistor 1.2K ELR $\frac{1}{2}$ J	711,811		
904			Q708,808	B-6006	Transistor 2SA495 (Y)
R705,805	B-5596	Carbon Resistor 220K ELR $\frac{1}{2}$ J	T701,801	B-3879	Headphone Trans.
708,808			VR704,804	B-7027	Volume 10K (B)x2
905			R728,828	B-5669	Carbon Resistor 180K ELR $\frac{1}{2}$ J
R706,806	B-1921	Carbon Resistor 330K ELR $\frac{1}{4}$ J	R729,829	B-5674	Carbon Resistor 820K ELR $\frac{1}{2}$ J
906			R730,830	B-1920	Carbon Resistor 100K ELR $\frac{1}{2}$ J
R707,807	B-5593	Carbon Resistor 150K ELR $\frac{1}{2}$ J	738,838		
R907	B-5626	Carbon Resistor 150K R $\frac{1}{2}$ J	740,840		
R908	B-5625	Carbon Resistor 220K R $\frac{1}{2}$ J	R731,831	B-5664	Carbon Resistor 3.9K ELR $\frac{1}{2}$ J
R909	B-5575	Carbon Resistor 560 R $\frac{1}{2}$ J	R732,832	B-5649	Carbon Resistor 150 ELR $\frac{1}{2}$ J
C701,801	B-1412	Electrolytic Capacitor 10 μ 16V	R733,833	B-5505	Carbon Resistor 1.5K ELR $\frac{1}{2}$ J
704,804			R736,836	B-1792	Carbon Resistor 470 ELR $\frac{1}{2}$ J
901,904			R737,837	B-5661	Carbon Resistor 22K ELR $\frac{1}{2}$ J
C703,803	B-1389	Electrolytic Capacitor 4.7 μ 16V	R739,839	B-5565	Carbon Resistor 1.2K ELR $\frac{1}{2}$ J
903			R741,841	B-5568	Carbon Resistor 120K ELR $\frac{1}{2}$ J
C905	B-1401	Electrolytic Capacitor 470 μ 25V	R742,842	B-5673	Carbon Resistor 5.6K ELR $\frac{1}{2}$ J
C702,802	B-1405	Electrolytic Capacitor 1 μ 16V	C714,814	B-1405	Electrolytic Capacitor 1 μ 16V
902			720,820		
C761,861	B-1288	Seramic Capacitor 100P 50V M	722,822		
961			718,818		
— Mixing Amp. & Limiter —			C715,815	B-1289	Seramic Capacitor 220P 50V M
Q703,803	B-6003	Transistor 2SC1000 (BL)	C716,816	B-5599	Seramic Capacitor 150P 50V M
704,804			C717,817	B-1389	Electrolytic Capacitor 4.7 μ 16V
Q705,805	B-6005	Transistor 2SC732 (BL)	719,819		
Q706-806	B-1600	FET 2SK30 (Y)	721,821		
D701,801	B-1909	Silicon Diode 1S1555	C723,823	B-1412	Electrolytic Capacitor 10 μ 16V
702,802			C907	B-1673	Electrolytic Capacitor 1000 μ 18V
VR702,802	B-7024	Volume 50K (A)x2		B-7550	Front Control P.C.B.
VR703,803	B-1470	Semi-fixed Volume 5K			
R719	B-5671	Carbon Resistor 2.2M R $\frac{1}{2}$ J			
R725,825	B-5700	Carbon Resistor 470K ELR $\frac{1}{2}$ J			
R709,809	B-1564	Carbon Resistor 82K ELR $\frac{1}{2}$ J			
R710,810	B-5508	Carbon Resistor 56K R $\frac{1}{2}$ J			
R711,811	B-5563	Carbon Resistor 56K ELR $\frac{1}{2}$ J			
R712	B-1795	Carbon Resistor 4.7K ELR $\frac{1}{2}$ J			
R713,813	B-5668	Carbon Resistor 82K R $\frac{1}{2}$ J			
R714,814	B-5597	Carbon Resistor 680K ELR $\frac{1}{2}$ J			
R715,815	B-5591	Carbon Resistor 15K ELR $\frac{1}{2}$ J			
R716,816	B-5566	Carbon Resistor 2.2K ELR $\frac{1}{2}$ J			
R717,817	B-5669	Carbon Resistor 180K ELR $\frac{1}{2}$ J			
R718,818	B-5576	Carbon Resistor 470 R $\frac{1}{2}$ J			
R720,820	B-1902	Carbon Resistor 68K ELR $\frac{1}{2}$ J			
R721,821	B-5650	Carbon Resistor 12K ELR $\frac{1}{2}$ J			
R722,822	B-5608	Carbon Resistor 220 ELR $\frac{1}{2}$ J			
R723,823	B-5511	Carbon Resistor 820 ELR $\frac{1}{2}$ J			
R724,824	B-5569	Carbon Resistor 47 ELR $\frac{1}{2}$ J			
R726	B-5625	Carbon Resistor 220K R $\frac{1}{2}$ J			
R727	B-1878	Carbon Resistor 8.2K ELR $\frac{1}{2}$ J			
R744,844	B-5562	Carbon Resistor 47K ELR $\frac{1}{2}$ J			
R812	B-1846	Carbon Resistor 4.7K ELR $\frac{1}{2}$ J			
R819	B-5672	Carbon Resistor 2.2M ELR $\frac{1}{2}$ J			
R826	B-5596	Carbon Resistor 220K ELR $\frac{1}{2}$ J			
R827	B-1856	Carbon Resistor 8.2K ELR $\frac{1}{2}$ J			
R910	B-1788	Carbon Resistor 68 ELR $\frac{1}{2}$ J			

X

11.7. Logic Control P.C.B.

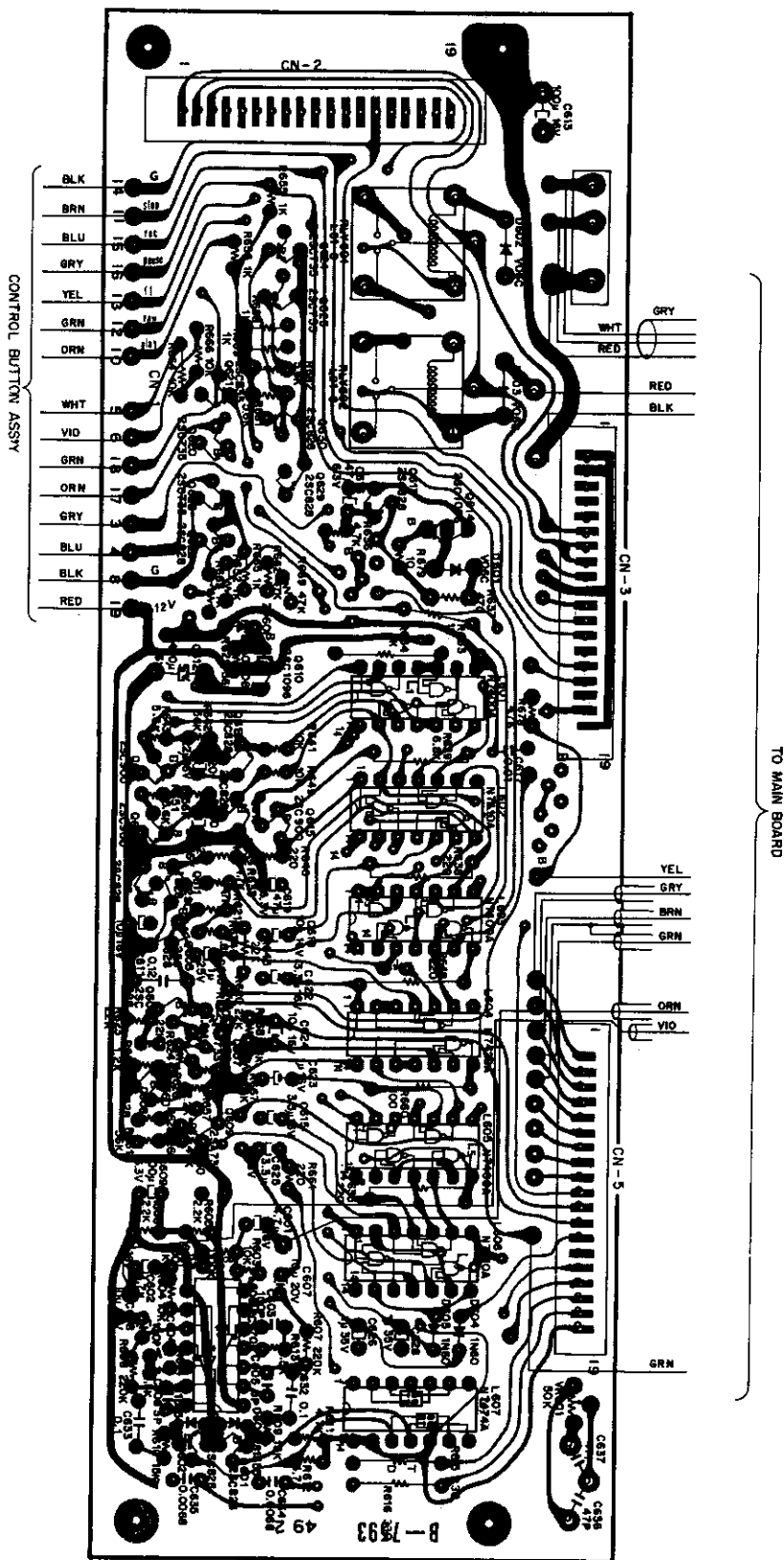

Serial No. 3707221-

Fig. 11.7

11.5. Switch P.C.B.

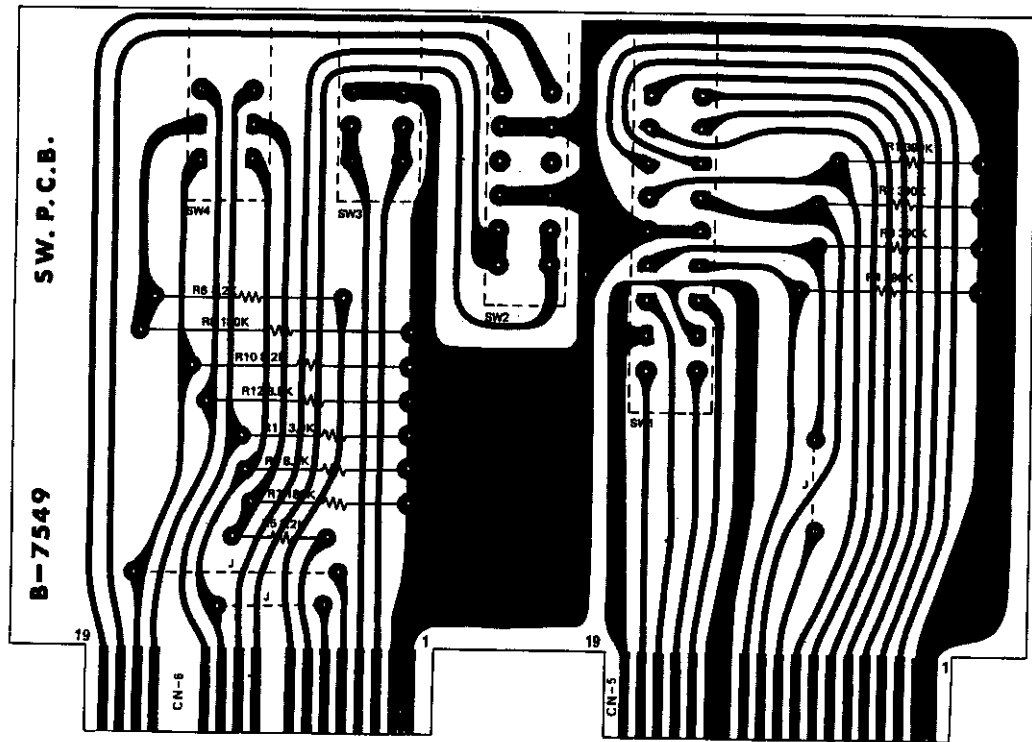
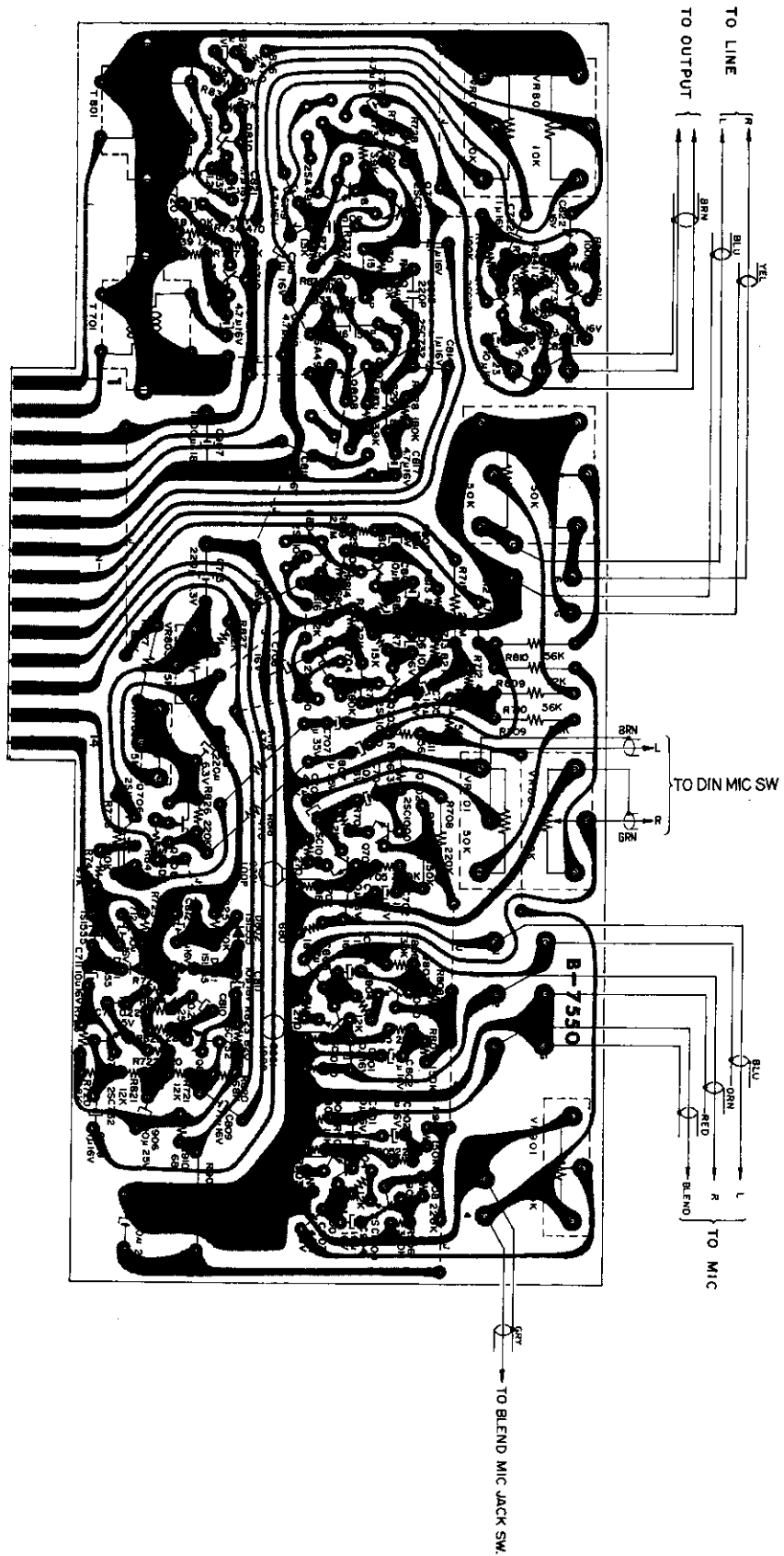

Fig. 11.5

Schematic Ref No.	Part No.	Description
	BA-3609 Sw. Board Ass'y	
R1,2,3,4	B-5676	Carbon Resistor 390K R¼ J
R5,6,9,10	B-1856	Carbon Resistor 8.2K R¼ J
R7,8	B-5640	Carbon Resistor 180K R¼ J
R11,12	B-5675	Carbon Resistor 3.9K R¼ J
	B-7025	Push Button
	B-7549	Sw. P.C.B.

X

11.6. Front Control P.C.B.



Serial No. 3705511.

Fig. 11.6

Schematic Ref. No.	Part No.	Description	Schematic Ref. No.	Part No.	Description
	BA-3689 Logic Control P.C.B. Ass'y		C611	B-1772	Mylar Capacitor 0.12 μ 50V K
L 601,603	B-6041	IC N7400A	C612	B-1392	Electrolytic Capacitor 470 μ 16V
605			C613	B-1400	Electrolytic Capacitor 100 μ 16V
L 602,606	B-6042	IC N7410A	C614,618	B-1412	Electrolytic Capacitor 10 μ 16V
L 604	B-6043	IC N7420A	624		
L 607	B-6044	IC N7474A	C615,622	B-1863	Electrolytic Capacitor 3.3 μ 16V
L 608	B-6027	IC RC4709	625		
Q601,602	B-1824	Transistor 2SC828(Q/R)	C616,619	B-1404	Electrolytic Capacitor 47 μ 6.3V
605,606			C617	B-1609	Mylar Capacitor 0.01 μ 50V K
608,611			C620,621	B-1862	Electrolytic Capacitor 22 μ 16V
612,613			C626,628	B-5638	Tantalum Capacitor 1 μ 35V M
616,618			C632,633	B-1603	Mylar Capacitor 0.1 μ 50V K
622,			C634,635	B-5530	Mylar Capacitor 6800P 50V K
629,630			C636,637	B-1456	Ceramic Capacitor 47P 50V M
Q607,609	B-6013	Transistor 2SA-733	VR601	B-7058	Semi-fixed Volume 50K
Q610,614	B-6020	Transistor 2SC-1096	RLY601,602	B-7001	Relay LC1-C
Q615,617	B-1910	Transistor 2SC-900		B-3067	Wiring Holder
619				B-8001	Tub
Q620,621	B-1338	Transistor 2SC-735		BA-3696	19P Connector Ass'y (D)
623,624				BA-3562	19P Connector Sub. Ass'y
625				BA-3627	Headphone Separate Plug Cord Ass'y
D601,602	B-1501	Silicon Diode VO6C		C-5157	P.C.B Holder (A)
603				E-507	Nut M3
D604,605	B-30	Germanium Diode IN60		E-518	Screw M3 \times 8 Flat Head
D606,607	B-1909	Silicon Diode 1S1555		E-581	Washer 3 Spring
ZD601	B-6014	Zener Diode EQA01-06R		E-607	Screw M3 \times 8 Philips Pan Head
R601,602	B-1920	Carbon Resistor 100K ELR $\frac{1}{4}$ J		B-7593	Logic Control P.C.B.
R603,604	B-1833	Carbon Resistor 10K ELR $\frac{1}{4}$ J			
641,649					
664,666					
R605,606	B-5566	Carbon Resistor 2.2K ELR $\frac{1}{4}$ J			
657					
R607,608	B-5596	Carbon Resistor 220K ELR $\frac{1}{4}$ J			
R609,610	B-5591	Carbon Resistor 15K ELR $\frac{1}{4}$ J			
R611,612	B-1795	Carbon Resistor 4.7K ELR $\frac{1}{4}$ J			
621,625					
632,633					
636,678					
R613,614	B-5505	Carbon Resistor 1.5K ELR $\frac{1}{4}$ J			
R615,616	B-5577	Carbon Resistor 330 R $\frac{1}{4}$ J			
R620,623	B-5661	Carbon Resistor 22K ELR $\frac{1}{4}$ J			
624,645					
R622	B-5670	Carbon Resistor 1.8M ELR $\frac{1}{4}$ J			
R626,629	B-5678	Carbon Resistor 560 ELR $\frac{1}{4}$ J			
R627	B-5565	Carbon Resistor 1.2K ELR $\frac{1}{4}$ J			
R628,643	B-5673	Carbon Resistor 5.6K ELR $\frac{1}{4}$ J			
651,681					
682					
R630,	B-5562	Carbon Resistor 47K ELR $\frac{1}{4}$ J			
662,669					
R631,642	B-5563	Carbon Resistor 56K ELR $\frac{1}{4}$ J			
650					
R634	B-1830	Carbon Resistor 1.8K ELR $\frac{1}{4}$ J			
R635,638	B-1933	Carbon Resistor 220 R $\frac{1}{4}$ J			
648					
R637	B-5572	Carbon Resistor 470 RD $\frac{1}{2}$ J			
R639	B-1682	Carbon Resistor 6.8K R $\frac{1}{4}$ J			
R640,661	B-5608	Carbon Resistor 220 ELR $\frac{1}{4}$ J			
R652,653	B-1781	Carbon Resistor 1K ELR $\frac{1}{4}$ J			
654,655					
656,658					
659,663					
665,667					
R660	B-1679	Carbon Resistor 100 R $\frac{1}{4}$ J			
R668	B-1877	Carbon Resistor 6.8K ELR $\frac{1}{4}$ J			
R679	B-5663	Carbon Resistor 10 ELR $\frac{1}{4}$ J			
C601,602	B-5657	Tantalum Capacitor 4.7 μ 16V M			
C603,604	B-1288	Ceramic Capacitor 100P 50V M			
C605,606	B-5745	Ceramic Capacitor 3P 50V M			
C607,608	B-5581	Tantalum Capacitor 10 μ 20V M			
C609	B-1411	Electrolytic Capacitor 100 μ 6.3V			
C610,623	B-1405	Electrolytic Capacitor 1 μ 16V			

X

11.8. Motor Governor P.C.B.

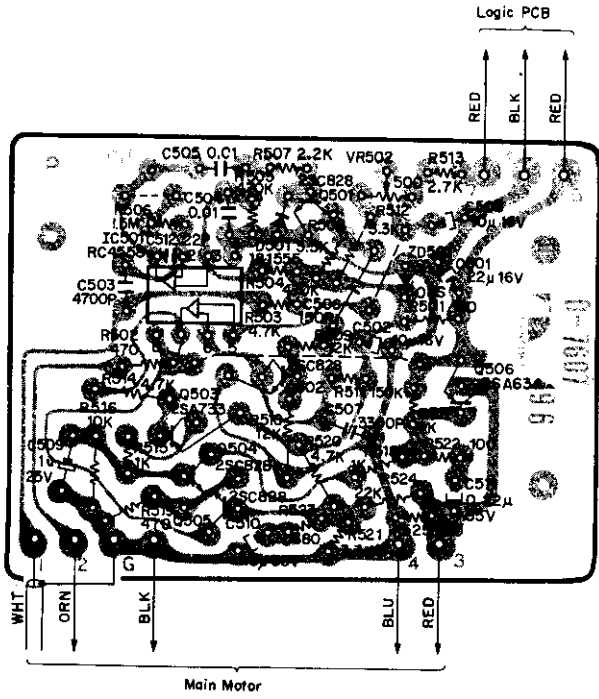

11.10. Shut-off Sensor P.C.B. and Shut-off Luminous P.C.B.

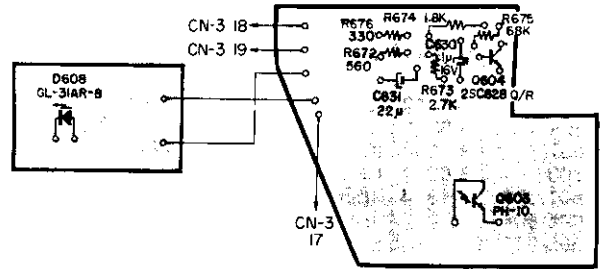

11.11. Head Base Sw. P.C.B.

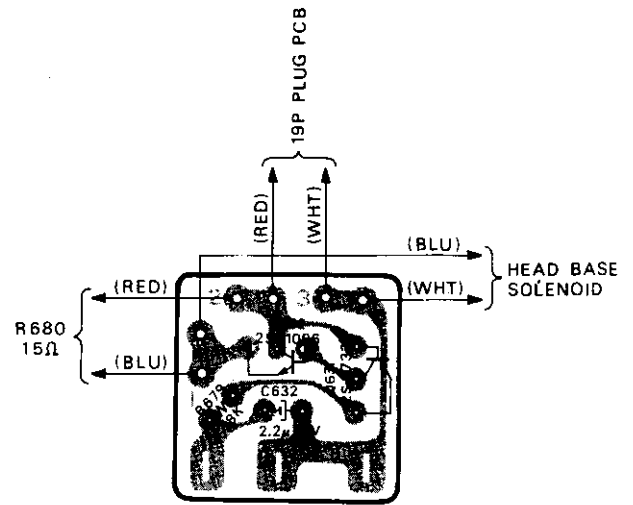

11.9. 400Hz Osc. Sw. P.C.B.

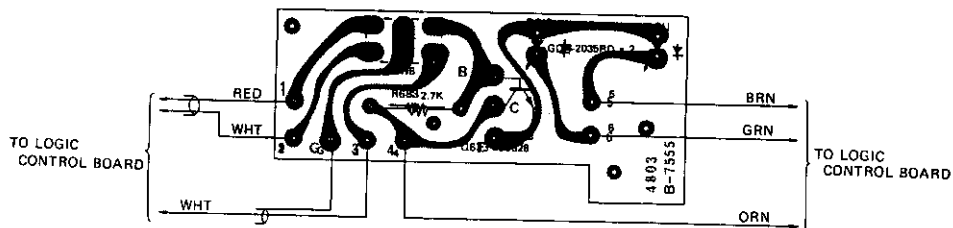

Schematic Ref. No.	Part No.	Description	Schematic Ref. No.	Part No.	Description
BA-3662 Motor Governor P.C.B. Ass'y			BA-3663 Shut-off Luminous P. C. B. Ass'y		
IC501	B-6049	IC RC4558	D608	B-6039	L.E.D. GL-31AR-8
Q501,502	B-1824	Transistor 2SC828	B-7575		Shut-off Luminous P.C.B.
Q503	B-6013	Transistor 2SA733	BA-3666 Head Base Switch P.C.B. Ass'y		
Q506	B-6012	Transistor 2SA634	Q631	B-6013	Transistor 2SA733
D501	B-1909	Silicon Diode 1S1555	Q632	B-1895	Transistor 2SC1096
ZD501	B-6004	Zener Diode EQA01-08S	R679	B-5561	Carbon Resistor 18K ELR $\frac{1}{4}$ J
R501	B-5607	Carbon Resistor 180 ELR $\frac{1}{4}$ J	C632	B-5512	Electrolytic Capacitor 2.2 μ 16V
R502,519	B-1792	Carbon Resistor 470 ELR $\frac{1}{4}$ J	B-7578		Base Switch Sub. P.C.B.
R503,514	B-1795	Carbon Resistor 4.7K ELR $\frac{1}{4}$ J			
520					
R504,505	B-5700	Carbon Resistor 470K ELR $\frac{1}{4}$ J			
R506	B-5601	Carbon Resistor 1.5M ELR $\frac{1}{4}$ J			
R507	B-5566	Carbon Resistor 2.2K ELR $\frac{1}{4}$ J			
R508,512	B-1793	Carbon Resistor 3.3K ELR $\frac{1}{4}$ J			
521					
R509,510	B-5650	Carbon Resistor 12K ELR $\frac{1}{4}$ J			
R511	B-5628	Metal Film Resistor 150K $\frac{1}{4}$ D Z			
R513	B-1782	Carbon Resistor 2.7K ELR $\frac{1}{4}$ J			
R515,517	B-1781	Carbon Resistor 1K ELR $\frac{1}{4}$ J			
518					
R516	B-1833	Carbon Resistor 10K ELR $\frac{1}{4}$ J			
R522	B-5558	Carbon Resistor 100 ELR $\frac{1}{4}$ J			
R523	B-5559	Carbon Resistor 680 ELR $\frac{1}{4}$ J			
R524	B-5661	Carbon Resistor 22K ELR $\frac{1}{4}$ J			
R525	B-5608	Carbon Resistor 220 ELR $\frac{1}{4}$ J			
C501	B-1862	Electrolytic Capacitor 22 μ 16V			
C502,508	B-1412	Electrolytic Capacitor 10 μ 16V			
C503	B-1915	Mylar Capacitor 4700P 50V			
C504,505	B-1609	Mylar Capacitor 0.01 μ 50V K			
C506	B-5599	Ceramic Capacitor 150P 50V M			
C507	B-5552	SP Capacitor 3300P 100V			
C509	B-5742	Tantalum Capacitor 1 μ 25V M			
C510	B-5639	Tantalum Capacitor 1.5 μ 35V M			
C511	B-5772	Tantalum Capacitor 0.22 μ 35V M			
C512	B-5806	Ceramic Capacitor 22P 50V K			
VR502	B-1883	Semi-fixed Volume 500			
	B-8069	Heat Sink			
	B-8077	Motor Governor P.C.B. Holder			
	E-71	Washer 3 Fiber			
	E-507	Nut Hex M3			
	E-510	Screw M3x8 Philips Pan Head			
	E-597	Washer 3			
	E-606	Screw M3x6 Philips Pan Head			
	E-608	Screw M3x10 Philips Pan Head			
	B-7607	Motor Governor P.C.B. (C)			
BA-3678 400Hz Osc. Sw. P.C.B. Ass'y 700					
Q633	B-1824	Transistor 2SC828 (Q/R)			
D610,611	B-6028	L.E.D. GD-4-2035RD			
R683	B-5629	Carbon Resistor 2.7K R $\frac{1}{4}$ J			
	B-7029	Slide Swtch SW-210 A=9			
	C-5422	Switch Cover			
	B-7555	400Hz Osc. Sw. P.C.B.			
BA-3664 Shut-off Sensor P.C.B. Ass'y					
Q603	B-6040	Photo-transistor PH-10			
Q604	B-1824	Transistor 2SC828(Q/R)			
R672	B-5678	Carbon Resistor 560 ELR $\frac{1}{4}$ J			
R673	B-1782	Carbon Resistor 2.7K ELR $\frac{1}{4}$ J			
R674	B-1830	Carbon Resistor 1.8K ELR $\frac{1}{4}$ J			
R675	B-1902	Carbon Resistor 68K ELR $\frac{1}{4}$ J			
R676	B-1789	Carbon Resistor 330 ELR $\frac{1}{4}$ J			
C630	B-1405	Electrolytic Capacitor 1 μ 16V			
C631	B-1862	Electrolytic Capacitor 22 μ 16V			
	B-7574	Shut-off Sensor P.C.B.			

11. 12. Power Supply P.C.B.

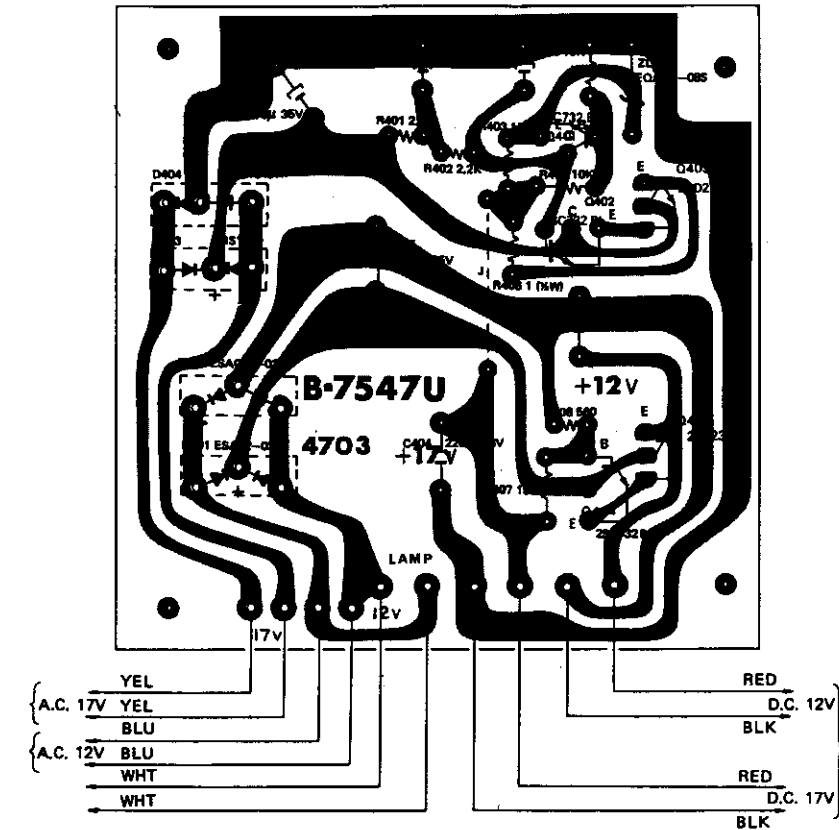

Fig. 11.12

Schematic Ref. No.	Part No.	Description
BA-3608 Power Supply Ass'y		
Q401,402	B-6005	Transistor 2SC732 (BL)
404		
Q403,405	B-1823	Transistor 2SD235 (Y)
D401	B-6025	Silicon Diode ESAC02-03C
D402	B-6026	Silicon Diode ESAC02-03N
D403	B-6037U	Silicon Diode 1S1849
D404	B-6038U	Silicon Diode 1S1849R
ZD401	B-6004	Zener Diode EQA01-08S
R401,402	B-5566	Carbon Resistor 2.2K ELR $\frac{1}{4}$ J
R403	B-1781	Carbon Resistor 1K ELR $\frac{1}{4}$ J
R404,405	B-1833	Carbon Resistor 10K ELR $\frac{1}{4}$ J
R406	B-66	Carbon Resistor 1 R $\frac{1}{4}$ J
R407	B-5649	Carbon Resistor 150 ELR $\frac{1}{4}$ J
R408	B-5678	Carbon Resistor 560 ELR $\frac{1}{4}$ J
C401	B-5677	Electrolytic Capacitor 470 μ 35V
C402,403	B-1722	Electrolytic Capacitor 100 μ 25V
C404	B-1835	Electrolytic Capacitor 2200 μ 18V
C405	B-5654	Electrolytic Capacitor 2200 μ 25V
C406	B-1673	Electrolytic Capacitor 1000 μ 18V
	B-8001	Tub
	J-3182	Power Supply P.C.B. Holder
	E-606	Screw M3x6 Philips Pan Head (3A)
	J-3185	Heat sink
	E-507	Nut Hex M3
	E-607	Screw M3x8 Philips Pan Head (3A)
	E-608	Screw M3x10 Philips Pan Head (3A)
	B-7547	Power Supply P.C.B.

12. WIRING DIAGRAM

12.1. Amplifier

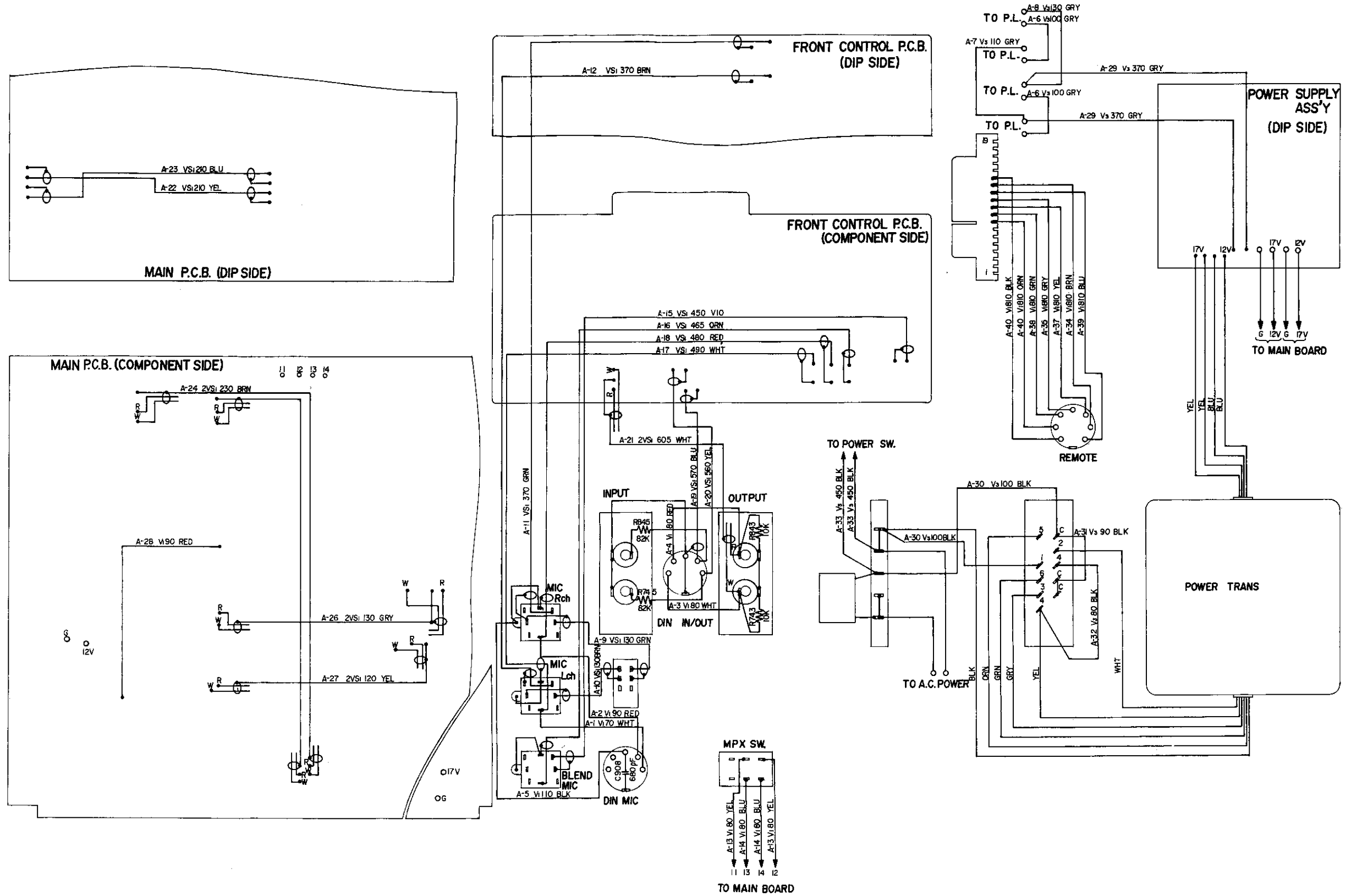
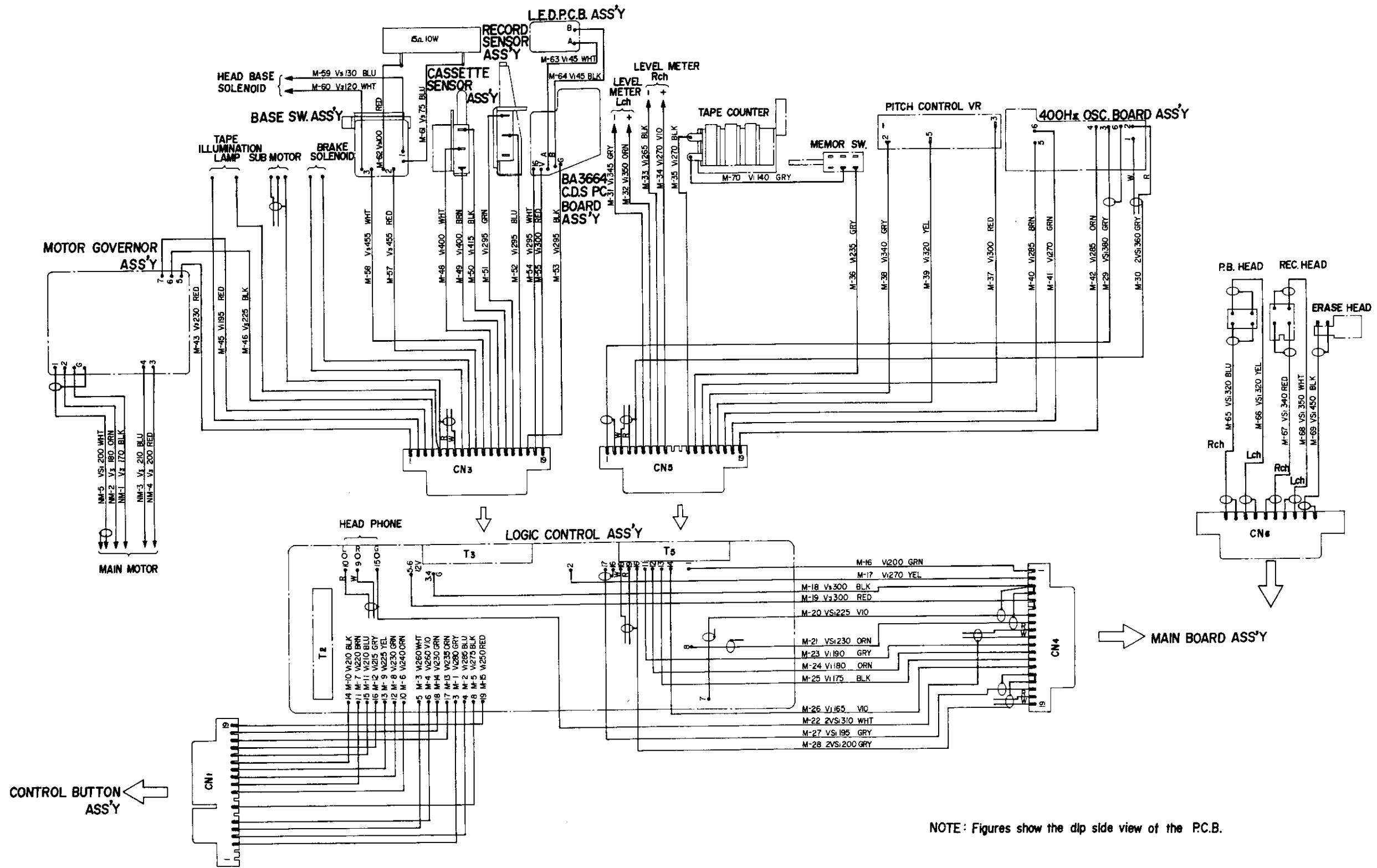

Fig. 12.1

Note: A1 V1-Process, 70-Length (mm), WHT-Color
 BLK-Black, GRY-Gray, VIO-Violet, BRN-Brown, BLU-Blue
 GRN-Green, YEL-Yellow, ORN-Orange, RED-Red, WHT-White

12.2. Logic Control



Note: M25 V1-Process, 175-Length (mm), BLK-Color
 BLK-Black, GRY-Gray, VIO-Violet, BRN-Brown, BLU-Blue
 GRN-Green, YEL-Yellow, ORN-Orange, RED-Red, WHT-White

NOTE: Figures show the dip side view of the P.C.B.

Fig. 12.2

13. LEVEL DIAGRAM

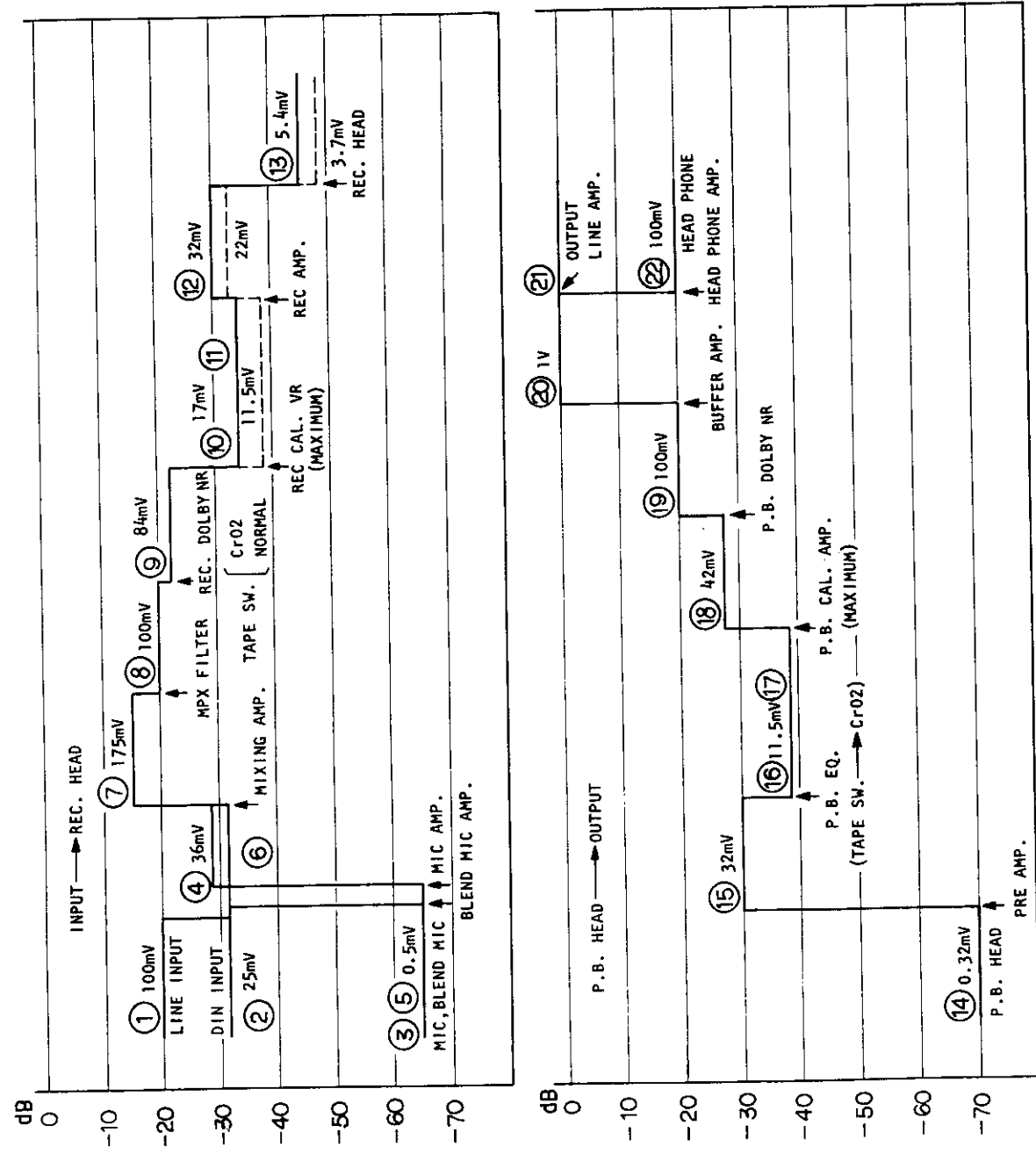

Fig. 13

14. EQ. AMP. FREQUENCY RESPONSE

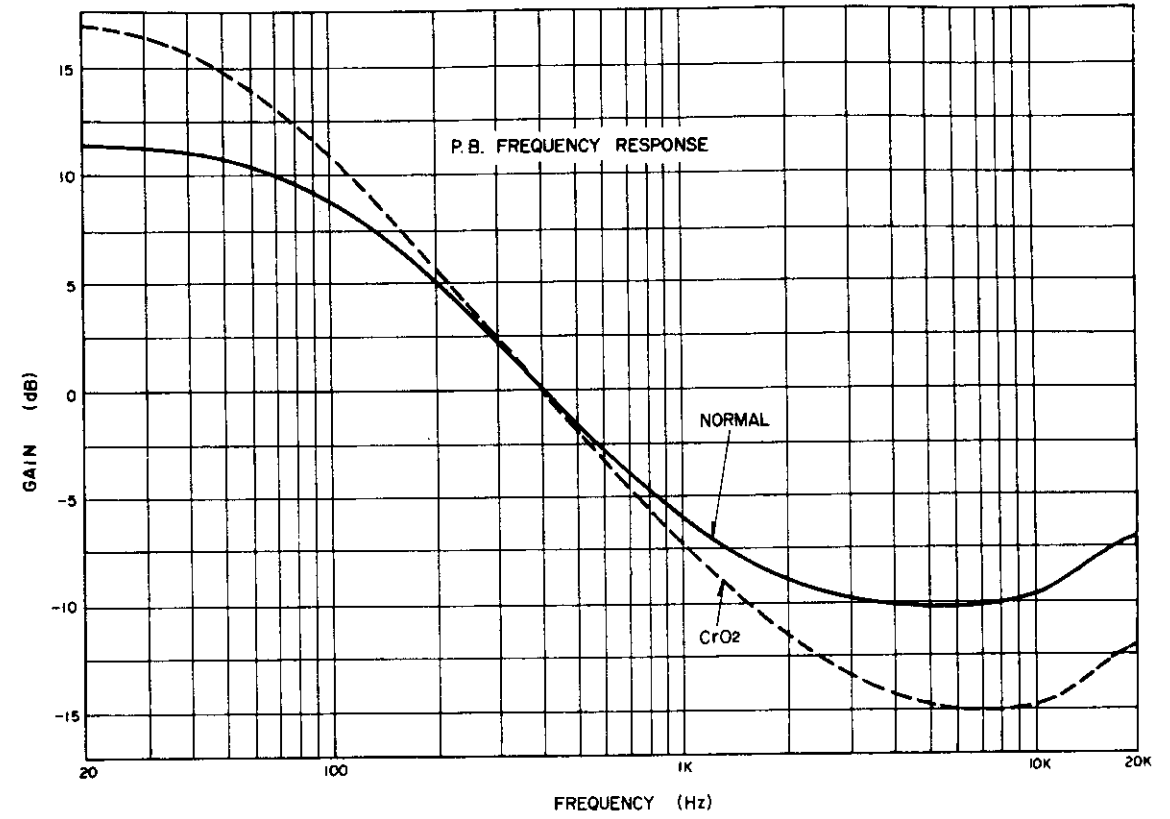

Fig. 14.1

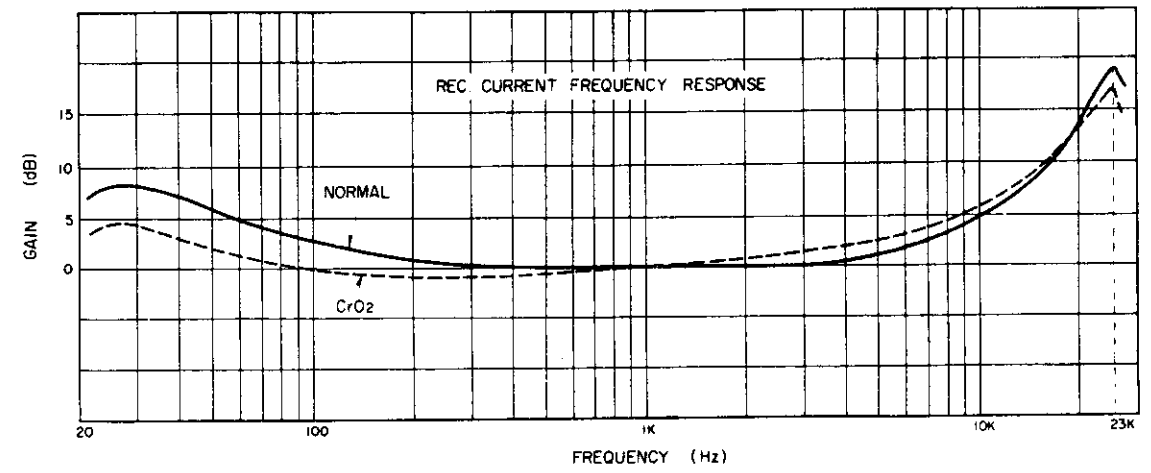

Fig. 14.2

15. BLOCK DIAGRAM

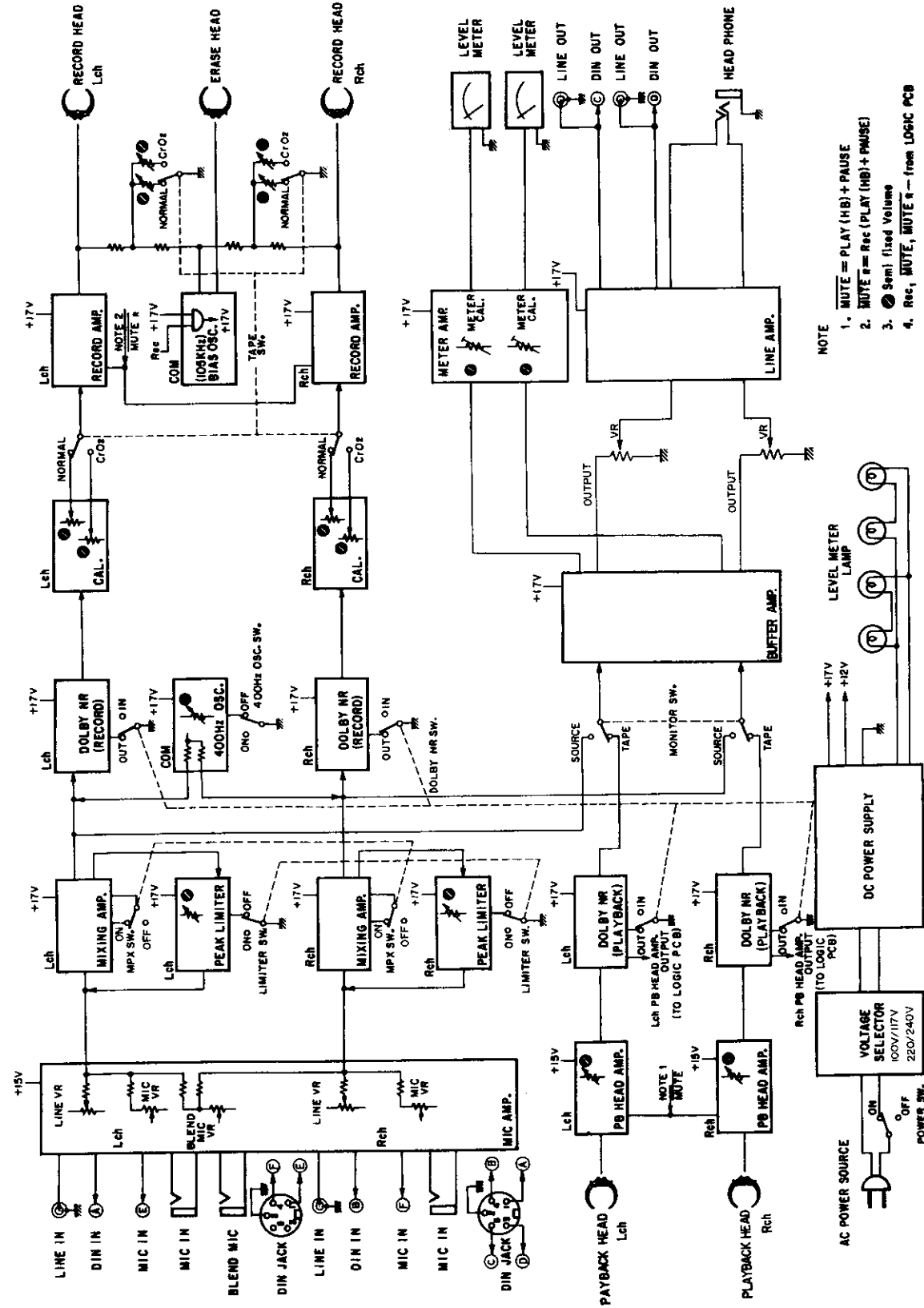
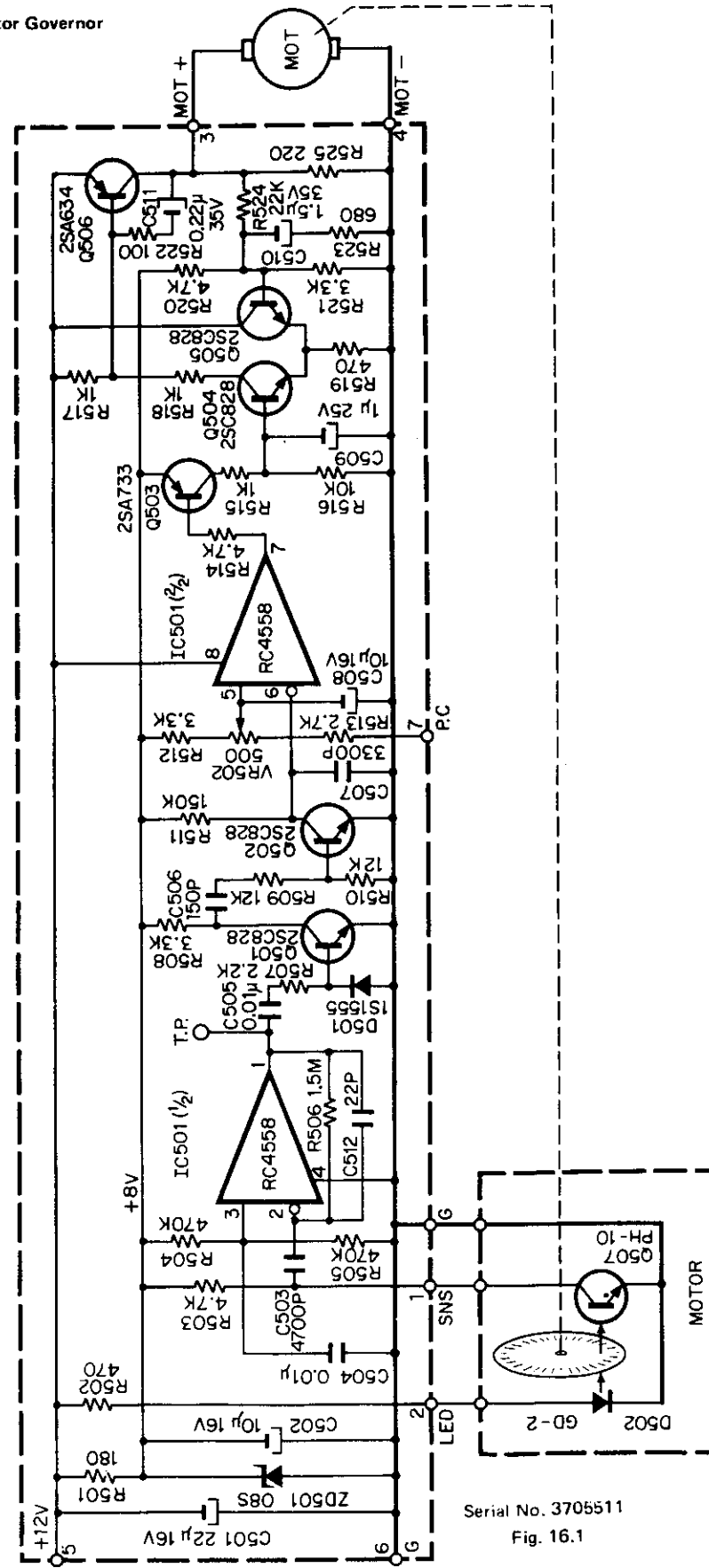

Fig. 15

16. SCHEMATIC DIAGRAM

16.1. Motor Governor



16.2. Amplifier

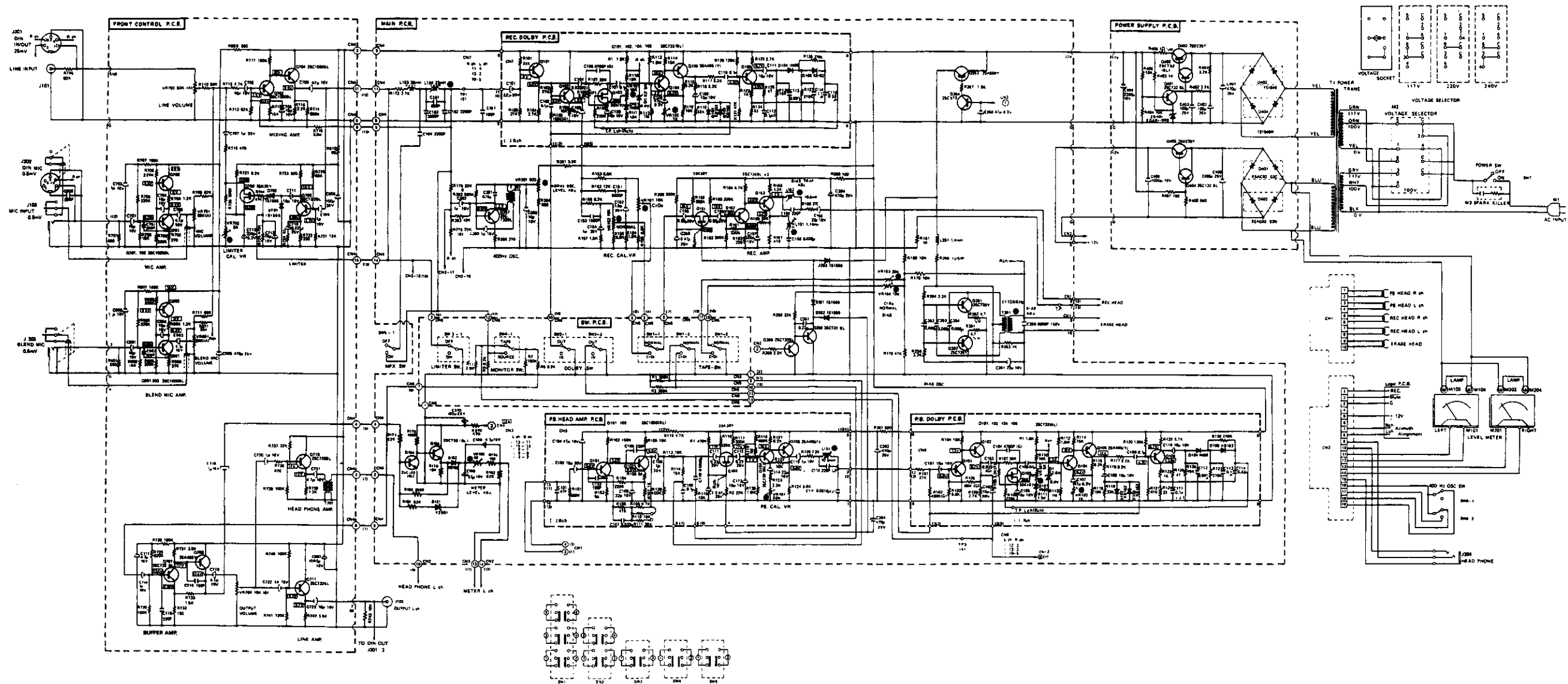

Note: R channel circuits are omitted when R channel circuits are equal to the L channel.
 Part Nos. 100-199, 700-799 show L channel's parts and 200-299, 800-899 show R channel's one. (For example R101 is an L channel's resistor and omitted R201 is an R channel's.)
 Part No. 300-399, 400-499, 900-999 show common parts for both channels. () shows a R channel's terminal No.

Serial No. 3705511-
 Fig. 16.2

16.3. Logic Control

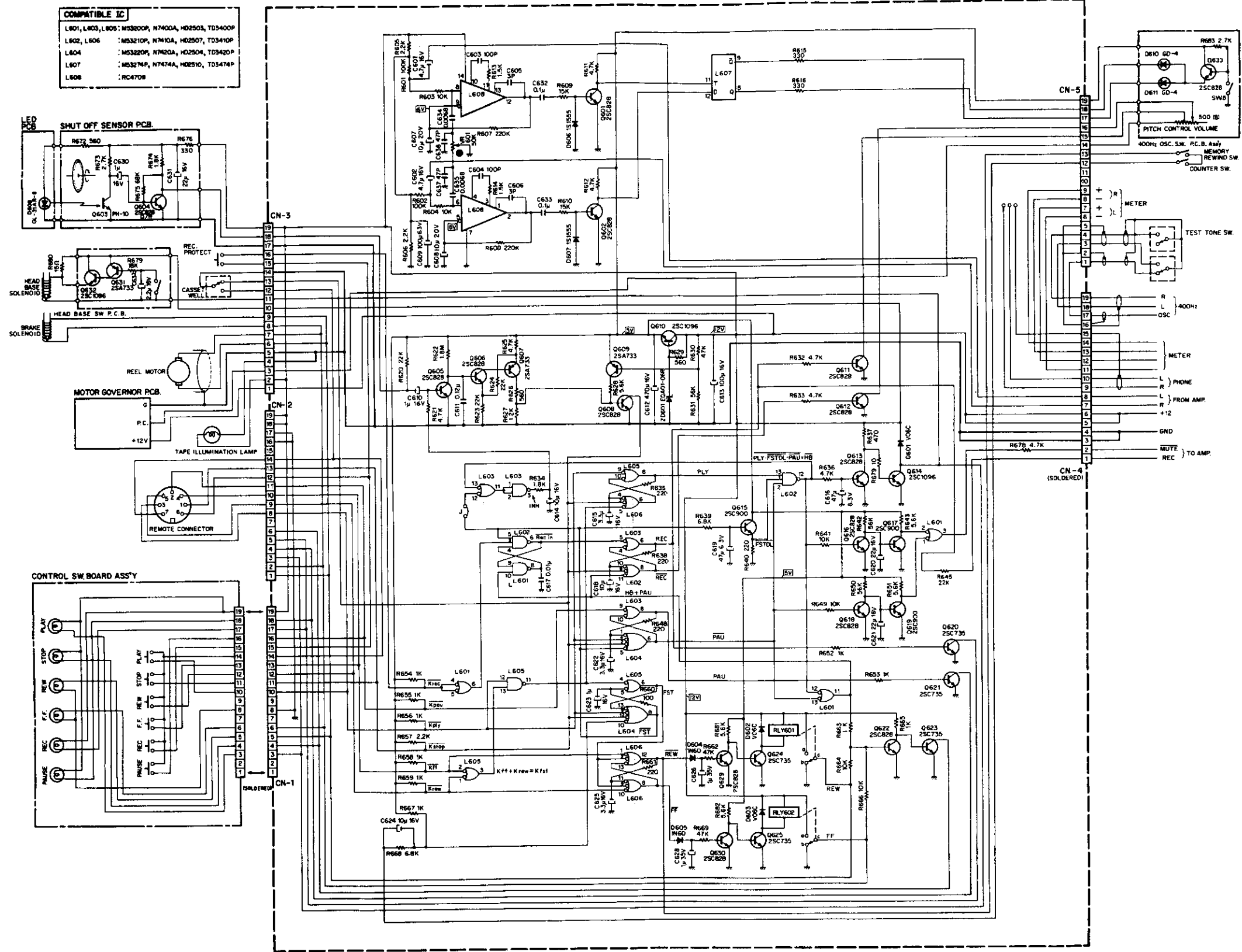

Serial No. 3707221
Fig.16.3

17. SPECIFICATIONS

Power Supply	100, 117, 220, 240V 50/60Hz
Power Consumption	60W Max.
Tape Speed	1-7/8 ips. \pm 1%
Wow & Flutter	Less than 0.1% (DIN 45507 Weighted Peak)
Frequency Response	35–18,000Hz \pm 3dB (Dolby In, High Density Low Noise Tape) 35–20,000Hz \pm 3dB (Dolby In, CrO ₂ Tape)
Signal to Noise Ratio	Better than 60 dB (Dolby In, Wrms CCITT 400Hz 3% Distortion)
Total Harmonic Distortion	Less than 2% (at 1 KHz, 0 dB)
Erasure	Better than 60 dB (at 1 KHz, Saturation Level)
Channel Separation	Better than 35 dB (at 1 KHz, 0 dB)
Cross Talk	Better than 60 dB (at 1 KHz, 0 dB)
Bias Frequency	105 KHz
Input:	
Mic Input	600 ohm 0.5 mV
Blend Mic	600 ohm 0.5 mV
DIN Mic Input	600 ohm 0.5 mV
Line	100 K ohm 100 mV
DIN Radio	26 K ohm 25 mV
Output:	
Line	1.0 V (Max.) Variable
DIN Line Output	1.0 V (Max.) Variable
Headphones	1 mW 0 dB
Dimensions	20-1/2" (W) x 10-11/16" (H) x 5-1/8" (D)
Weight	28 lbs.