

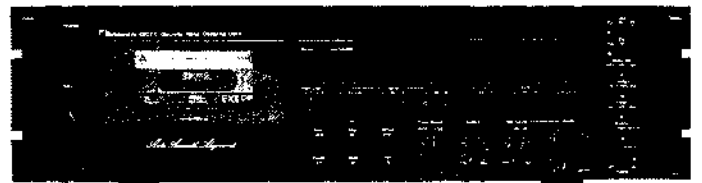

Service Manual

Nakamichi 680ZX

Discrete Head Cassette Deck





CONTENTS

1. General	3
2. Removal Procedures	5
2. 1. Side Panel Ass'y	5
2. 2. Top Cover Ass'y	5
2. 3. Bottom Cover Ass'y	5
2. 4. Cassette Case Cover Ass'y and Azimuth Alignment Cover Ass'y	5
2. 5. Front Panel Ass'y	5
2. 6. Headphone Jack Ass'y	5
2. 7. Mechanism Ass'y	5
2. 8. FL Indicator Ass'y	6
2. 9. Auto Azimuth P.C.B. Ass'y	6
2. 10. Logic P.C.B. Ass'y	6
2. 11. Switch P.C.B. Ass'y	6
2. 12. Main P.C.B. Ass'y	6
2. 13. Volume P.C.B. Ass'y	6
2. 14. Record Cal. P.C.B. A Ass'y, Record Cal. P.C.B. B Ass'y and Lamp P.C.B. A Ass'y	6
2. 15. Power Switch	6
2. 16. Lamp P.C.B. B Ass'y and Lamp P.C.B. C Ass'y	6
2. 17. Control Switch P.C.B. Ass'y	7
2. 18. Indicator P.C.B. Ass'y	7
2. 19. Rear Panel Ass'y	7
2. 20. Power Transformer and Fuse P.C.B. Ass'y	7
2. 21. Cassette Case Ass'y and Cover Plate Ass'y	7
2. 22. Tape Counter Ass'y, Memory Switch and Pitch Control Volume	7
2. 23. Capstan Motor Ass'y and Flywheel Ass'y	7
2. 24. Sub Mechanism Chassis Ass'y	7
2. 25. Control Motor Ass'y and Reel Motor Ass'y	7
2. 26. Cam Control Volume	8
2. 27. Azimuth Motor Ass'y	8
2. 28. Reel Hub Ass'y and Idler Ass'y	8
2. 29. Cam Drive Gear and Control Cam	8
2. 30. Head Mount Base Ass'y	9
2. 31. Pressure Roller Ass'y and Erase Head	9
2. 32. Playback Head Ass'y and Record Head Ass'y	9
3. Measurement Instruments	10
4. Mechanical Adjustments	11
4. 1. Mechanism Control Cam Adjustment	11
4. 2. Tape Speed Adjustment	12
4. 3. Record Head and Playback Head Tilt Adjustment	13
4. 4. Head Base Stroke Adjustment in Play and Cue Modes	14
4. 5. Tape Guides Adjustment and Erase Head Stroke Adjustment	15
4. 6. Erase Head Height and Tilt Adjustment	15
4. 7. Back Tension Adjustment	16
4. 8. Playback Head and Record Head Height Adjustment and Azimuth Alignment	17
4. 9. Record Head Stroke Adjustment	19
4. 10. Tape Travelling Adjustment	20
4. 11. Flywheel Holder Adjustment	20
4. 12. Lubrication	20
5. Parts Location for Electrical Adjustment	21
6. Electrical Adjustments and Measurements	22
6. 1. Adjustment and Measurement Instructions	22
6. 2. Frequency Response Adjustment	27
6. 3. Dolby NR Circuit Check	28
7. Mounting Diagrams	29
7. 1. Main P.C.B. Ass'y	29



7. 2.	Switch P.C.B. Ass'y	31
7. 3.	Record Cal. P.C.B. A Ass'y	31
7. 4.	Record Cal. P.C.B. B Ass'y	31
7. 5.	Logic P.C.B. Ass'y	33
7. 6.	Fuse P.C.B. Ass'y	35
7. 7.	Pin Jack P.C.B. Ass'y	36
7. 8.	Auto Shut-off P.C.B. Ass'y	36
7. 9.	Volume P.C.B. Ass'y	36
7. 10.	Auto Azimuth P.C.B. Ass'y	36
7. 11.	Control Switch P.C.B. Ass'y	37
7. 12.	Lamp P.C.B. A Ass'y	37
7. 13.	Lamp P.C.B. B Ass'y	37
7. 14.	Lamp P.C.B. C Ass'y	37
7. 15.	Indicator P.C.B. A Ass'y	37
7. 16.	Indicator P.C.B. B Ass'y	37
7. 17.	Indicator P.C.B. C Ass'y	38
8.	Mechanism Ass'y and Parts List	39
8. 1.	Synthesis	39
8. 2.	Front Panel Ass'y (A01)	42
8. 3.	Mechanism Ass'y 680ZX (A02)	43
8. 4.	Chassis Ass'y (A03)	46
8. 5.	Front Panel Escutcheon Ass'y (B01)	46
8. 6.	Control Button Ass'y (B02)	46
8. 7.	Flywheel Holder Ass'y (C01)	46
8. 8.	Sub Mechanism Chassis Ass'y (C02)	47
8. 9.	Main Mechanism Chassis Ass'y (C03)	50
8. 10.	FL Indicator Ass'y (D01)	55
8. 11.	Calibration Case Ass'y (D02)	55
8. 12.	Volume Holder Ass'y (D03)	55
8. 13.	Headphone Jack Ass'y (D04)	55
8. 14.	Reflector Ass'y (D05)	55
8. 15.	Counter Lamp Ass'y (D06)	55
8. 16.	Power Switch Holder Ass'y (D07)	55
8. 17.	Rear Panel Ass'y (D08)	58
8. 18.	Reel Motor Ass'y (E01)	58
8. 19.	Control Motor Ass'y (E02)	58
8. 20.	Azimuth Alignment Motor Ass'y (E03)	58
8. 21.	Head Mount Base Ass'y (F01)	58
8. 22.	Supply Pressure Roller Ass'y (F02)	58
8. 23.	Take-up Pressure Roller Ass'y (F03)	59
8. 24.	Head Base Ass'y D (F04)	59
8. 25.	Cassette Case Holder L Ass'y (F05)	59
8. 26.	Cassette Case Holder R Ass'y (F06)	59
8. 27.	Auto Shut-off Ass'y (F07)	59
8. 28.	Pneumatic Damper Ass'y (F08)	59
8. 29.	Pitch Control Holder Ass'y (F09)	59
8. 30.	Azimuth Motor Ass'y (G01)	59
8. 31.	P-8L Playback Head Ass'y (H01)	59
8. 32.	R-8L Record Head Ass'y (H02)	59
9.	Overall Timing Chart	61
10.	Eq. Amp. Frequency Response	62
10. 1.	Standard Speed (1-7/8 ips)	62
10.1.1.	Playback Frequency Response	62
10.1.2.	Record Current Frequency Response	62
10. 2.	Half-Speed (15/16 ips)	62

10.2.1.	Playback Frequency Response	62
10.2.2.	Record Current Frequency Response	62
11.	Block Diagrams	63
11. 1.	Amplifier	63
11. 2.	Mechanism Control	64
12.	Wiring Diagram	65
13.	Schematic Diagrams	67
13. 1.	Amplifier	67
13. 2.	Mechanism Control	68
14.	Specifications	69

1. GENERAL

1.1. Control Functions

Nakamichi 680ZX control functions are shown below:

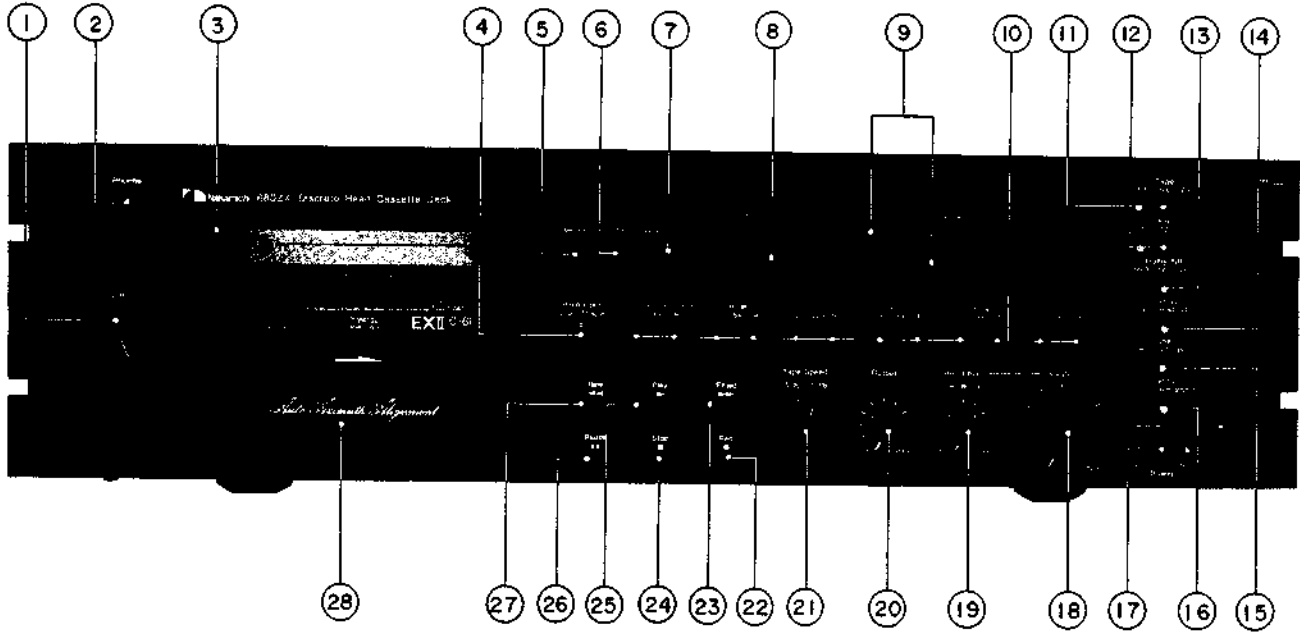

Fig. 1.1 Front View

- | | |
|--|----------------------------------|
| 1. Eject Lever | 15. Timer Switch |
| 2. Headphone Jack | 16. Monitor Switch |
| 3. Cassette Holder (with see-thru cover) | 17. Power Switch |
| 4. Pitch Control | 18. Master Input Level Control |
| 5. Tape Start Memory Switch | 19. Input Level Controls |
| 6. Counter Reset Button | 20. Output Level Control |
| 7. Tape Counter | 21. Tape Speed Selector |
| 8. RAMM Display | 22. Record Button |
| 9. Fluorescent (FL) Level Indicators | 23. Fast-Forward Button |
| 10. Record Calibration Controls | 24. Stop Button |
| 11. Tape Switch (EX/SX/ZX) | 25. Play Button |
| 12. Eq. Switch (120 μ s/70 μ s) | 26. Pause Button |
| 13. Dolby NR/MPX Filter Switch | 27. Rewind Button |
| 14. Display Switch | 28. Auto Azimuth Alignment Cover |

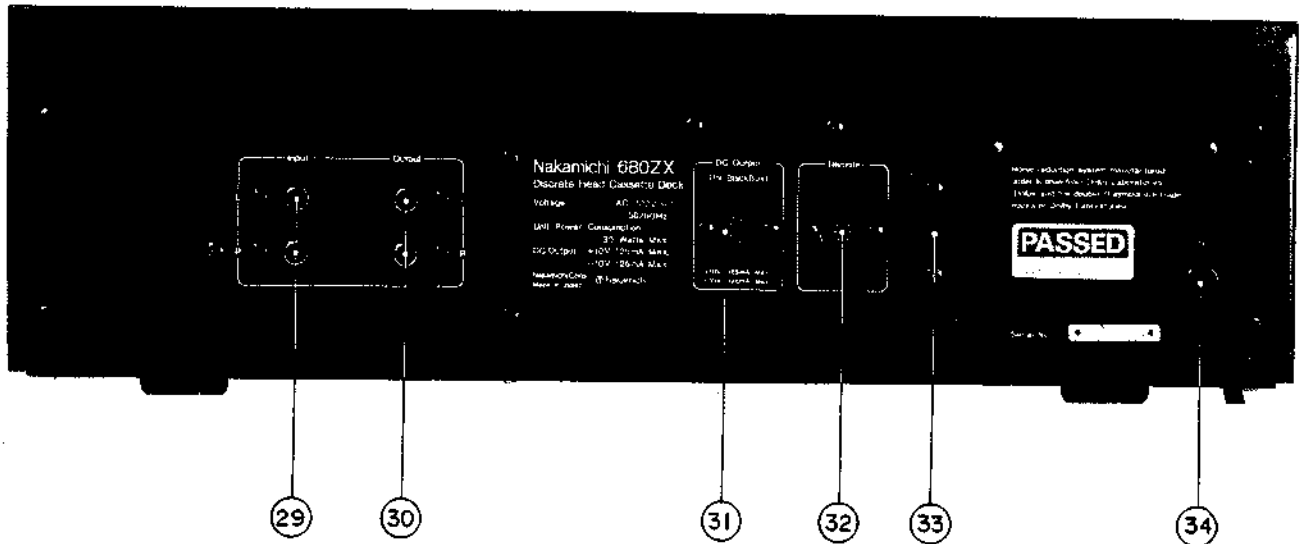

Fig. 1.2 Rear View

- | | |
|--------------------|---------------------------|
| 29. Input Jacks | 32. Remote Control Socket |
| 30. Output Jacks | 33. Voltage Selector |
| 31. DC Output Jack | 34. Power Cord |

1.2. Voltage Selector

Voltage selector is installed on the rear panel for other versions of the Nakamichi 680ZX. This voltage selector can select either 120 V or 220 – 240 V at customer's disposal.

2. REMOVAL PROCEDURES

2.1. Side Panel Ass'y

Refer to Fig. 2.1.

Remove F01 and F02, then disassemble F03 (Side Panel Ass'y)

2.2. Top Cover Ass'y

Refer to Fig. 2.1.

(1) Remove Side Panel Ass'y referring to item 2.1.

(2) Remove F04 and F05, then disassemble F06 (Top Cover Ass'y).

2.3. Bottom Cover Ass'y

Refer to Fig. 2.1.

Remove F07, then disassemble F08 (Bottom Cover Ass'y).

2.4. Cassette Case Cover Ass'y and Azimuth Alignment Cover Ass'y

Refer to Fig. 2.1.

(1) Turn fully counterclockwise two screws which are mounted on the Cassette Case Cover, then disassemble F09 (Cassette Case Cover Ass'y).

(2) Turn fully counterclockwise two screws which are mounted on the Front Panel Escutcheon Ass'y, then disassemble F10 (Azimuth Alignment Cover Ass'y).

2.5. Front Panel Ass'y

Refer to Fig. 2.2.

(1) Refer to Fig. 2.1. Remove Top Cover Ass'y and Bottom Cover Ass'y referring to items 2.2 and 2.3.

(2) Pull out F01 (Volume Knob A), F02 (Volume Knob L), F03 (Volume Knob R), F04 (Volume Knob B) and F05 (Pitch Control Knob).

(3) Remove F06, F07 and F08, then disassemble F09 (Front Panel Ass'y including 2 connectors).

2.6. Headphone Jack Ass'y

Refer to Fig. 2.2.

(1) Remove Front Panel Ass'y referring to item 2.5.

(2) Remove F10, then disassemble F11 (Headphone Jack Ass'y).

2.7. Mechanism Ass'y

Refer to Fig. 2.2.

(1) Remove Front Panel Ass'y referring to item 2.5.

(2) Remove F12, then disassemble F13 (Mechanism Ass'y including 7 connectors).

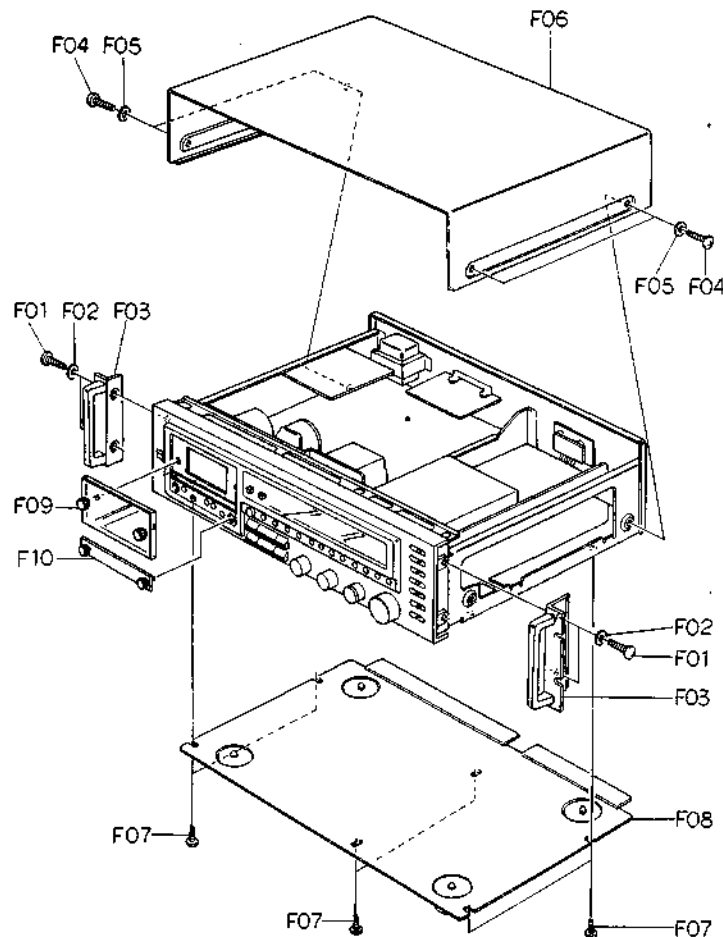

Fig. 2.1

2.8. FL Indicator Ass'y

Refer to Fig. 2.3.

- (1) Refer to Fig. 2.2. Remove Front Panel Ass'y referring to item 2.5.
- (2) Remove F01, then disassemble F02 (FL Indicator Ass'y including 3 connectors).

2.9. Auto Azimuth P.C.B. Ass'y

Refer to Fig. 2.3.

- (1) Refer to Fig. 2.2. Remove Front Panel Ass'y referring to item 2.5.
- (2) Remove one connector and the wires connected by wrapping.
- (3) Remove F03, then disassemble F04 (Auto Azimuth P.C.B. Ass'y)

2.10. Logic P.C.B. Ass'y

Refer to Fig. 2.3.

- (1) Refer to Fig. 2.2. Remove Front Panel Ass'y referring to item 2.5.
- (2) Remove 7 connectors and the wires connected by wrapping from F06 (Logic P.C.B. Ass'y).
- (3) Remove F05, then disassemble F06 (Logic P.C.B. Ass'y).

2.11. Switch P.C.B. Ass'y

Refer to Fig. 2.3.

- (1) Refer to Fig. 2.2. Remove Front Panel Ass'y referring to item 2.5.
- (2) Pull out F07 (Function Switch Knob Ass'y).
- (3) Remove the Flat Cables, connector and wires connected by wrapping from F10 (Switch P.C.B. Ass'y).
- (4) Remove F08 and F09, then disassemble F10 (Switch P.C.B. Ass'y).

2.12. Main P.C.B. Ass'y

Refer to Fig. 2.3.

- (1) Remove FL Indicator Ass'y and Switch P.C.B. Ass'y referring to items 2.8 and 2.11.
- (2) Remove the Flat Cables, 3 connectors and wires connected by wrapping from F12 (Main P.C.B. Ass'y).
- (3) Remove F11, then disassemble F12 (Main P.C.B. Ass'y).

2.13. Volume P.C.B. Ass'y

Refer to Fig. 2.3.

- (1) Remove FL Indicator Ass'y referring to item 2.8.
- (2) Remove F13 and the Flat Cable from F14 (Volume P.C.B. Ass'y), then disassemble F14 (Volume P.C.B. Ass'y).

2.14. Record Cal. P.C.B. A Ass'y, Record Cal. P.C.B. B Ass'y and Lamp P.C.B. A Ass'y

Refer to Fig. 2.3.

- (1) Refer to Fig. 2.2. Remove Front Panel Ass'y referring to item 2.5.
- (2) Remove F15, then disassemble F16 (Calibration Case Ass'y)
- (3) Remove F17, then disassemble F18 (Record Cal. P.C.B. A Ass'y).
- (4) Remove F19, then disassemble F20 (Record Cal. P.C.B. B Ass'y).
- (5) Remove F21, then disassemble F22 (Lamp P.C.B. A Ass'y).

2.15. Power Switch

Refer to Fig. 2.3.

- (1) Refer to Fig. 2.2. Remove Front Panel Ass'y referring to item 2.5.
- (2) Remove F23, then disassemble F24 (Power Switch Knob).
- (3) Remove F25, then disassemble F26 (Power Switch Holder Ass'y).
- (4) Remove F27, then disassemble F28 (Power Switch).

2.16. Lamp P.C.B. B Ass'y and Lamp P.C.B. C Ass'y

Refer to Fig. 2.3.

- (1) Refer to Fig. 2.2. Remove Front Panel Ass'y referring to item 2.5.
- (2) Remove F29, then disassemble F30 (Insulator) and F31 (Lamp P.C.B. B Ass'y).
- (3) Remove F32 (Lamp P.C.B. C Ass'y) by releasing the self-interlocking pin of the Reflector.

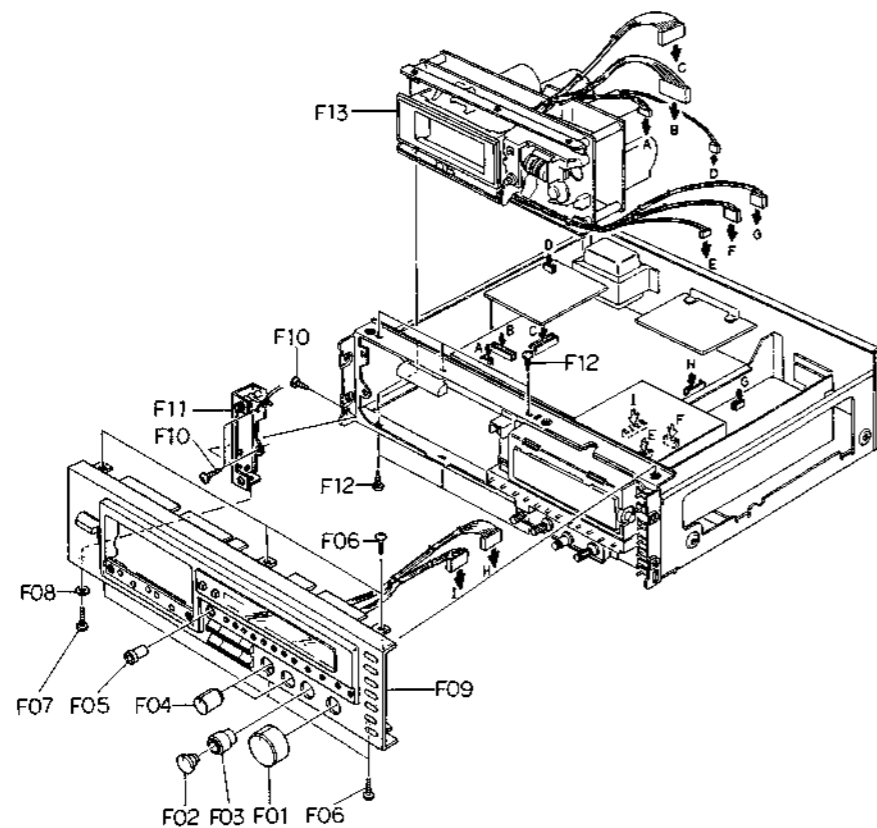

Fig. 2.2

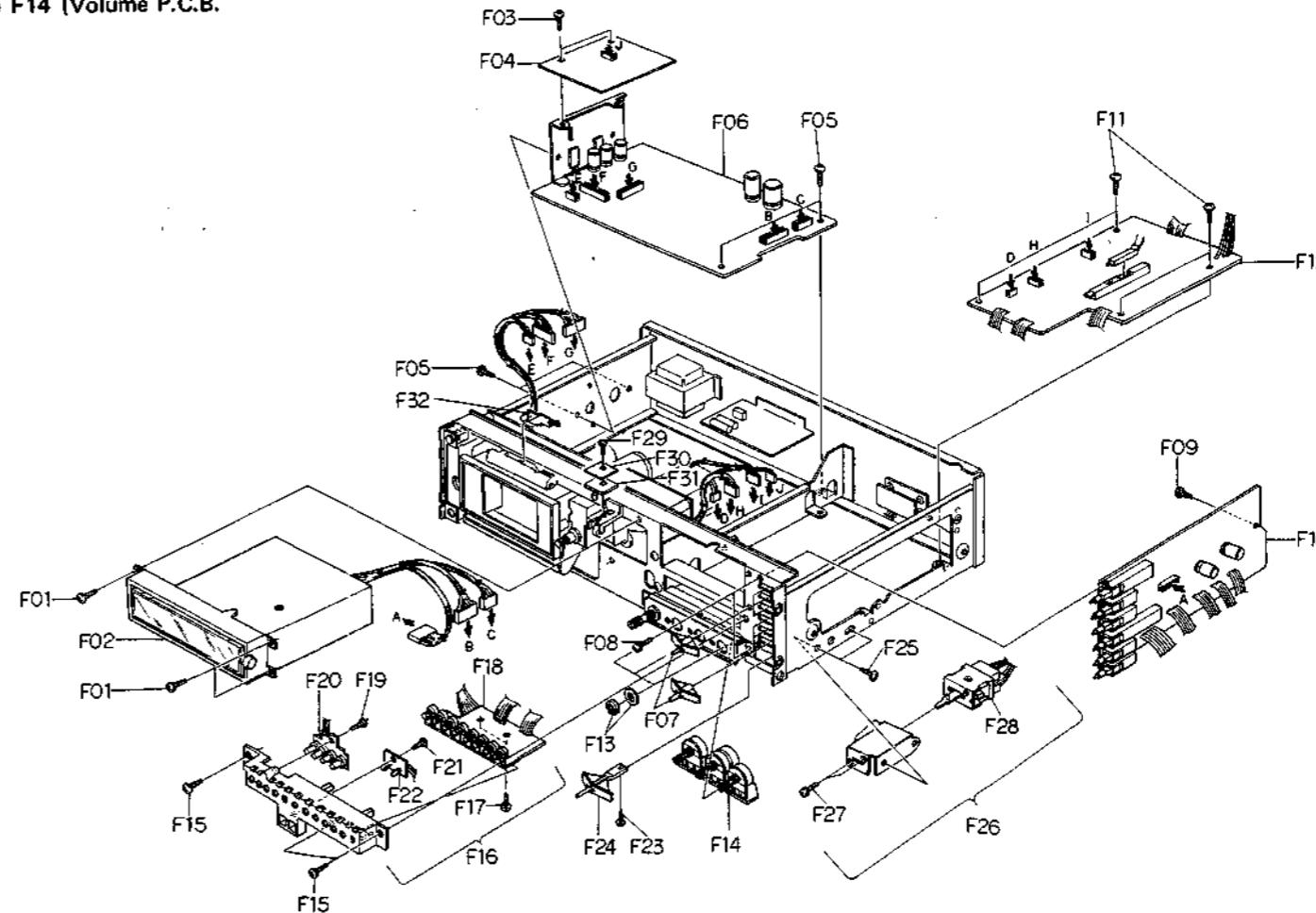

Fig. 2.3

2.17. Control Switch P.C.B. Ass'y

Refer to Fig. 2.4.

- (1) Refer to Fig. 2.2. Remove Front Panel Ass'y referring to item 2.5.
- (2) Remove F01, F02, F03 and F04, then disassemble F05 (Control Button Ass'y).
- (3) Remove F06, then disassemble F07 (Control Switch P.C.B. Ass'y).

2.18. Indicator P.C.B. Ass'y

Refer to Fig. 2.5.

- (1) Refer to Fig. 2.3. Remove FL Indicator Ass'y referring to item 2.8.
- (2) Remove F01, then disassemble F02 (Shield Cover).
- (3) Remove F03 (Indicator P.C.B. C Ass'y) by releasing the self-interlocking pin of the P.C.B. supporters.
- (4) Remove F04, then disassemble F05 (Indicator P.C.B. B Ass'y).
- (5) Remove F06 and F07, then disassemble F08 (FL Indicator Holder L), F09 (FL Indicator Holder R) and F10 (Indicator P.C.B. A Ass'y).

2.19. Rear Panel Ass'y

Refer to Fig. 2.6.

- (1) Refer to Fig. 2.1. Remove Top Cover Ass'y and Bottom Cover Ass'y referring to items 2.2 and 2.3.
- (2) Remove F01 and F02, then disassemble F03 (Rear Panel Ass'y).

2.20. Power Transformer and Fuse P.C.B. Ass'y

Refer to Fig. 2.6.

- (1) Refer to Fig. 2.1. Remove Top Cover Ass'y and Bottom Cover Ass'y referring to items 2.2 and 2.3.
- (2) Remove F04 and F05, then disassemble F06 (Power Transformer) and F07 (Transformer Plate).
- (3) Remove F08 and F09, then disassemble F10 (Fuse P.C.B. Ass'y).

2.21. Cassette Case Ass'y and Cover Plate Ass'y

Refer to Fig. 2.7.

- (1) Refer to Fig. 2.2. Remove Mechanism Ass'y referring to item 2.7.
- (2) Press the Eject Button to open the Cassette Case Ass'y.
- (3) Remove F01 and F02, then disassemble F03 (Cassette Case Holder L Ass'y) by releasing the self-interlocking pin of the Damper Lock Arm and F04 (Cassette Case Ass'y).
- (4) Remove F05, then disassemble F06 (Cover Plate Ass'y).

2.22. Tape Counter Ass'y, Memory Switch and Pitch Control Volume

Refer to Fig. 2.7.

- (1) Refer to Fig. 2.2. Remove Mechanism Ass'y referring to item 2.7.
- (2) Remove F07, then disassemble F08 (Tape Counter Ass'y).
- (3) Remove F09, then disassemble F10 (Pitch Control Holder Ass'y).
- (4) Remove F11, then disassemble F12 (Memory Switch).
- (5) Remove F13, then disassemble F14 (Pitch Control Volume).

2.23. Capstan Motor Ass'y and Flywheel Ass'y

Refer to Fig. 2.8.

- (1) Refer to Fig. 2.2. Remove Mechanism Ass'y referring to item 2.7.
- (2) Remove F01 and F02, then disassemble F03 (Flywheel Holder Ass'y) and F08 (Capstan Belt).
- (3) Remove F04, then disassemble F05 (Capstan Motor Ass'y).
- (4) Remove F06, then disassemble F07 (Speed Cal. P.C.B. Ass'y).
- (5) Remove F09 (Supply Flywheel Ass'y), then disassemble F10 (Take-up Flywheel Ass'y).
- (6) After removing both Flywheel Assemblies, disassemble F11 (Thrust Washer 3 mm), F12 (Thrust Washer 2.6 mm), F13 (Flange Thrust Cap) and F14 (Thrust Spring).

2.24. Sub Mechanism Chassis Ass'y

Refer to Fig. 2.9.

- (1) Remove Flywheel Holder Ass'y referring to item 2.23.
- (2) Remove F01 and F02, then disassemble F03 (Sub Mechanism Chassis Ass'y).

2.25. Control Motor Ass'y and Reel Motor Ass'y

Refer to Fig. 2.9.

- (1) Remove Sub Mechanism Chassis Ass'y referring to item 2.24.
- (2) Remove F04, then disassemble F05 (Control Motor Ass'y).
- (3) Remove F06, then disassemble F07 (Reel Motor Ass'y).

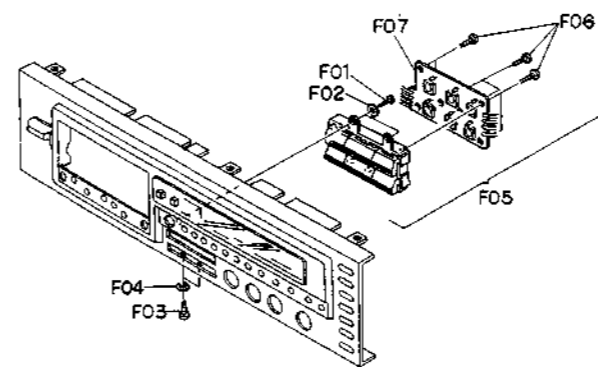

Fig. 2.4

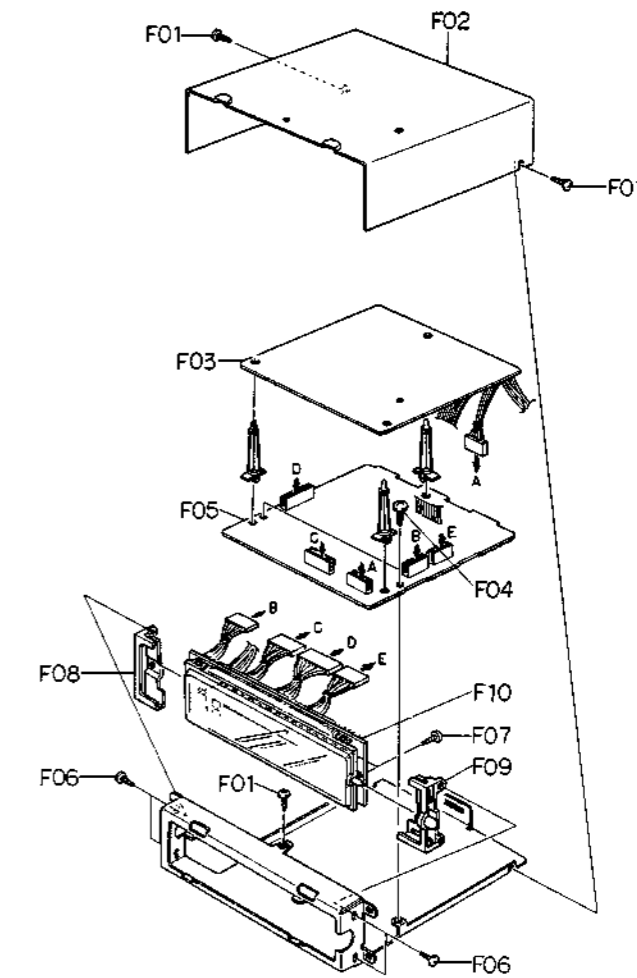

Fig. 2.5

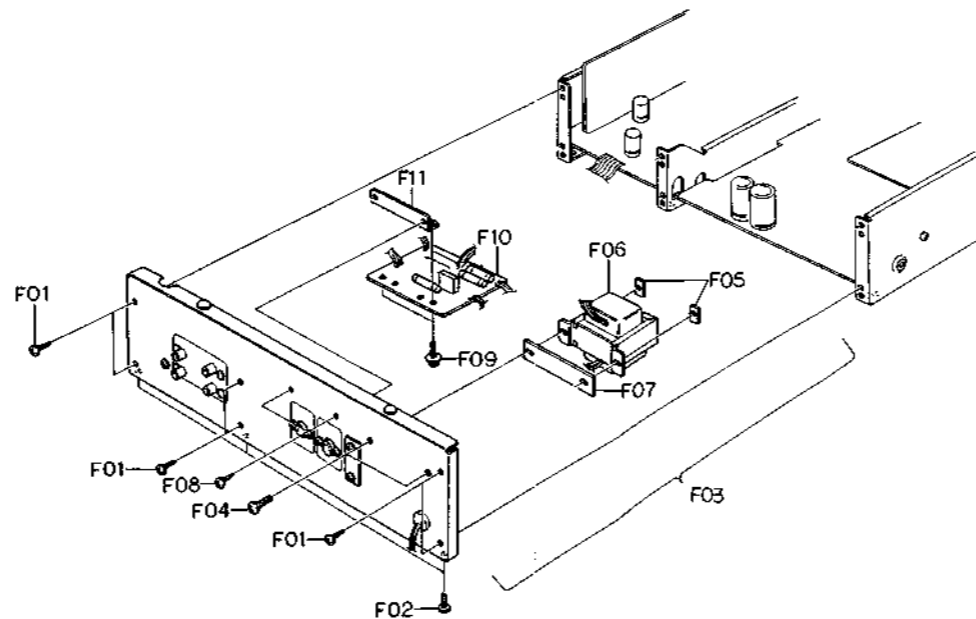

Fig. 2.6

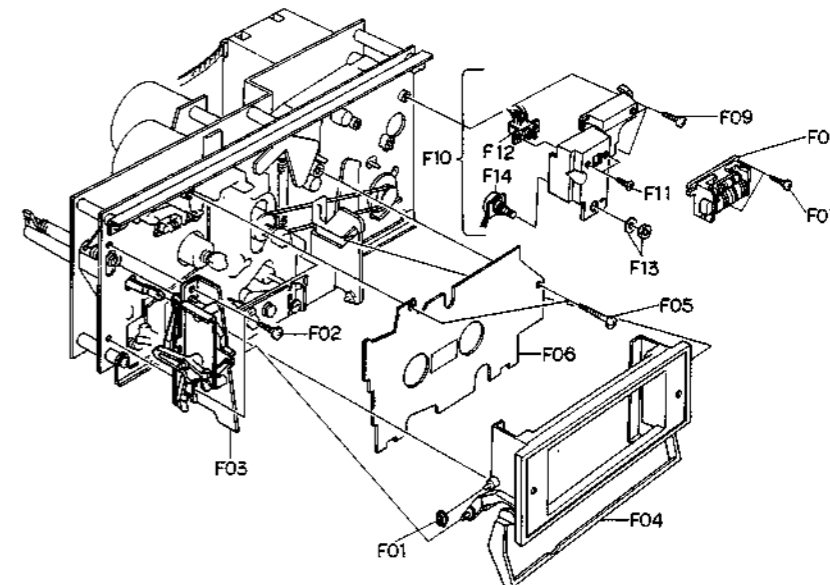

Fig. 2.7

2.26. Cam Control Volume

Refer to Fig. 2.9.

- (1) Remove Sub Mechanism Chassis Ass'y referring to item 2.24.
- (2) Remove F08, then disassemble F09 (Volume Coupler).
- (3) Remove F10, then disassemble F11 (Cam Control Volume).

2.27. Azimuth Motor Ass'y

Refer to Fig. 2.9.

- (1) Remove Sub Mechanism Chassis Ass'y referring to item 2.24.
- (2) Remove F12, then disassemble F13 (Azimuth Alignment Motor Ass'y).
- (3) Remove F14, then disassemble F15 (Azimuth Motor Ass'y) and F16 (Drive Pulley Ass'y).

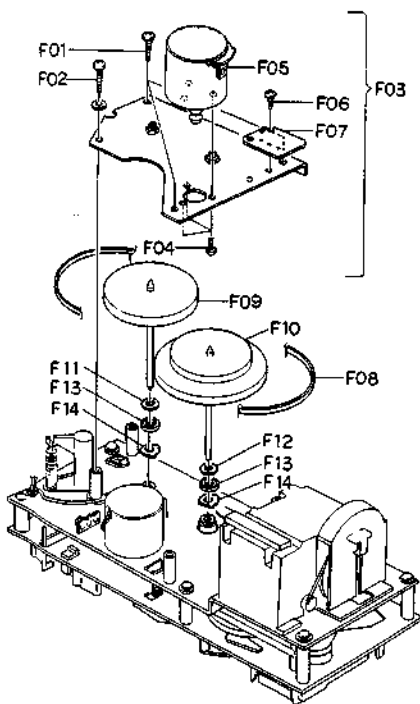

Fig. 2.8

2.28. Reel Hub Ass'y and Idler Ass'y

Refer to Fig. 2.9.

- (1) Remove Sub Mechanism Chassis Ass'y referring to item 2.24.
- (2) Remove F17 (Reel Hub Head), then disassemble F18 (Reel Hub B Ass'y), F19 (Reel Hub Take-up Ass'y), F20 (Reel Hub Supply Ass'y), F21 (Back Tension Ass'y) and F22 (Back Tension Spring).
- (3) Remove F23, then disassemble F24 (Idler Ass'y).

2.29. Cam Drive Gear and Control Cam

Refer to Fig. 2.9.

- (1) Remove Sub Mechanism Chassis Ass'y referring to item 2.24.
- (2) Remove F25, then disassemble F26 (Cam Drive Gear).
- (3) Remove F27, then disassemble F28 (Counter-Load Arm Ass'y).
- (4) Remove F29, then disassemble F30 (Control Cam).

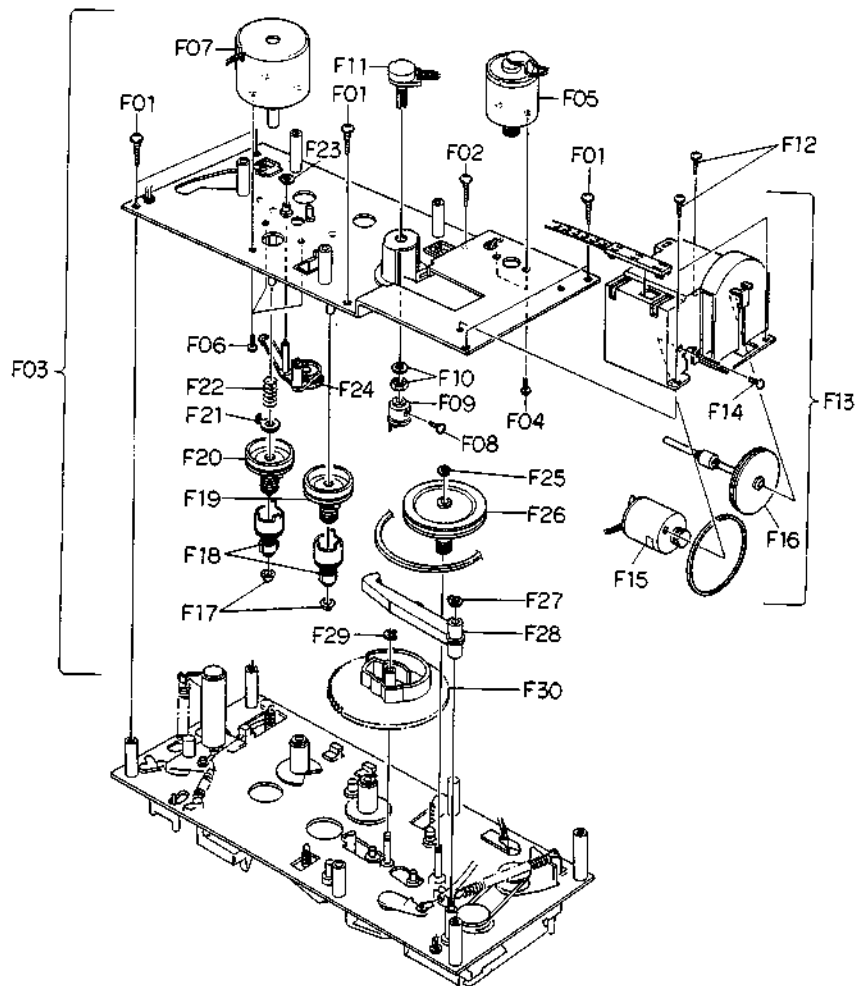

Fig. 2.9

2.30. Head Mount Base Ass'y

Refer to Fig. 2.10.

- (1) Refer to Fig. 2.7. Remove Cassette Case Ass'y referring to item 2.21.
- (2) Remove F01, then disassemble F02 (Head Mount Base Ass'y).

2.31. Pressure Roller Ass'y and Erase Head

Refer to Fig. 2.10.

- (1) Remove Head Mount Base Ass'y referring to item 2.30.
- (2) Remove F03, then disassemble F04 (Supply Pressure Roller Ass'y).
- (3) Remove F05, then disassemble F06 (Erase Head).
- (4) Remove F07, then disassemble F08 (Take-up Pressure Roller Ass'y).

2.32. Playback Head Ass'y and Record Head Ass'y

Refer to Fig. 2.10.

- (1) Remove Head Mount Base Ass'y referring to item 2.30.
- (2) Turn F09 by 90° by pushing it, then disassemble F10 (Playback Head Ass'y).
- (3) Turn F10 by 90° by pushing it, then disassemble F12 (Record Head Ass'y) and F13 (RH Azimuth Alignment Plate).

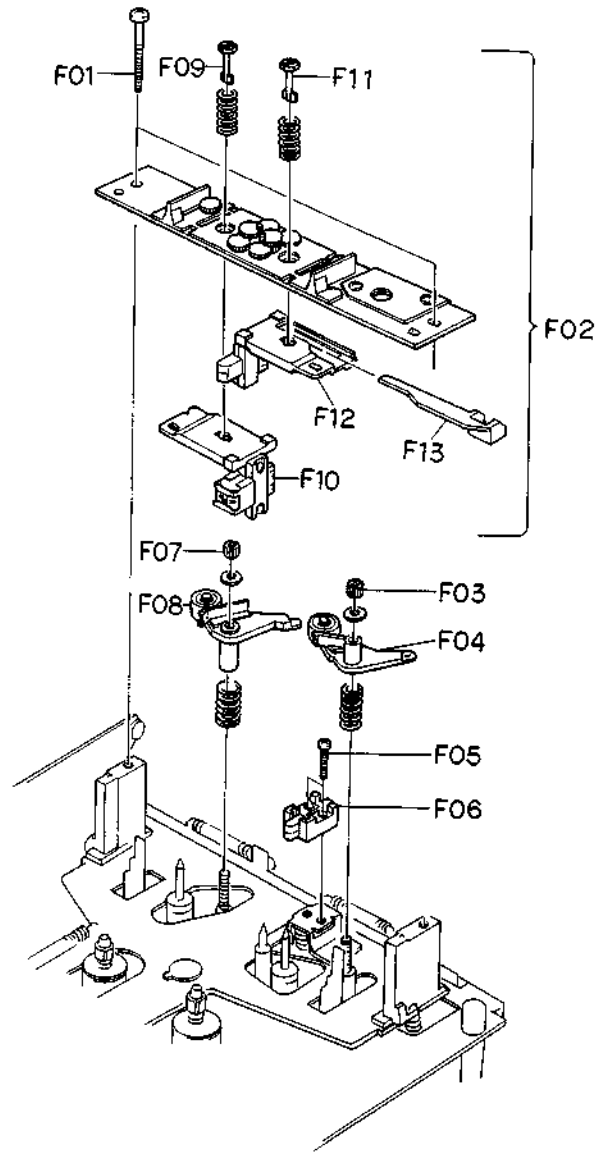

Fig. 2.10

3. MEASUREMENT INSTRUMENTS

- (1) Audio Generator (20 Hz – 200 kHz)
- (2) AC Millivolt Meter (with dB measures)
- (3) Oscilloscope (DC – 5 MHz)
- (4) Distortion Meter
- (5) Speed & Wow/Flutter Meter
- (6) Frequency Counter (DC – 1 MHz)
- (7) Ohm Meter
- (8) DC Volt Meter
- (9) AC Volt Meter
- (10) Torque Gauge (DA09013A)
- (11) 15 kHz Azimuth Tape (DA09004A)
- (12) 3 kHz Speed & Wow/Flutter Tape (DA09006A) for Standard Speed (1-7/8 ips)
- (13) 3 kHz Speed & Wow/Flutter Tape (DA09049A) for Half-Speed (15/16 ips)
- (14) 1 kHz Track Alignment Tape (DA09007A)
- (15) 400 Hz Level Tape (DA09005A)
- (16) 20 kHz PB Frequency Response Tape (DA09001A)
- (17) 15 kHz PB Frequency Response Tape (DA09002A)
- (18) 10 kHz PB Frequency Response Tape (DA09003A)
- (19) Reference EXII Tape (DA09021A)
- (20) Reference SX Tape (DA09025A)
- (21) Reference ZX Tape (DA09037A)
- (22) Tilt Check Gauge M-9039 (DA09039A)
- (23) EH Tilt Check Gauge M-9040 (DA09040A)
- (24) EH Stroke Check Gauge M-9042 (DA09042A)
- (25) EH Stroke Check Gauge M-9051 (DA09051A)
- (26) Stroke Check Gauge M-9047 (DA09047A)
- (27) Record Head Mounting Gauge M-9048 (DA09048A)
- (28) Back Tension Gauge (DA09055A)
- (29) Tension Arm Adjustment Cassette (DA09056A)
- (30) Audio Analyzer T-100
(including Distortion, Wow/Flutter, Speed, Oscillator and dB meter)

Notes: 1. (10) – (30) are the products of Nakamichi Corporation.

2. EH Stroke Check Gauge M-9042 (DA09042A) should be used for the Models serial Nos. from A11601001 to A11603009, and EH Stroke Check Gauge M-9051 (DA09051A) is for the Models bearing serial Nos. A11603010 and greater.

3. Back Tension Gauge (DA09055A) and Tension Arm Adjustment Cassette (DA09056A) are used for the Models bearing serial Nos. A11606264 and greater.

4. MECHANICAL ADJUSTMENTS

4.1. Mechanism Control Cam Adjustment

Before adjustment, disassemble the Front Panel Ass'y, then remove the Cover Plate referring to items 2.5 and 2.21.

(1) Offset Adjustment of Control Motor Driver

(a) Refer to Figs. 4.1 and 4.2.

Adjust VR402 and VR403 on the Logic P.C.B. to locate approximately at the middle of the variable range. Then turn ON the Power Switch.

VR402 (for Cam position stop)

VR403 (for Cam position play)

(b) Press the Stop Switch to set the N-680ZX in stop mode.

Adjust VR402 (for stop) so that the "S" mark on the Cam corresponds to the pointer on the mechanism chassis.

(c) Press the Play Switch to set the N-680ZX in playback mode.

(Cam will rotate, and the position marked with "PY" comes to the pointer.) Adjust VR403 (for play) so that the "PY" mark on the Cam corresponds to the pointer.

(d) Repeat above (b) and (c) 2 - 3 times so that the "S" and "PY" marks on the Cam correspond to the pointer accurately in stop and playback modes respectively.

(This adjustment is required because the position adjusted by one volume will be slightly changed when the other volume is adjusted.)

(e) Set the N-680ZX in FF, pause, or cue mode by pressing each switch (press FF and Pause Switches to set the N-680ZX in cue mode) and check to insure that the pointer is in a range of "F", "PS", or "CU" mark respectively.

(f) If out of the range, precise adjustment for each position according to "(2) Offset Fine Adjustment of Control Motor Driver" will be required.

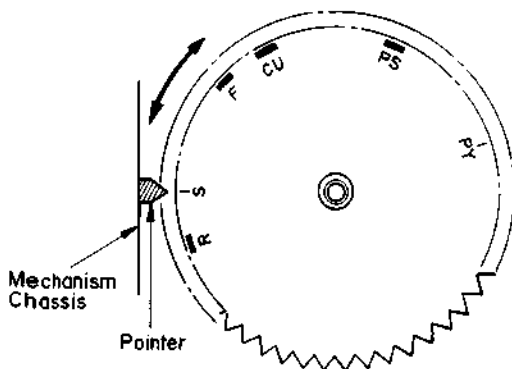

Fig. 4.1

(2) Offset Fine Adjustment of Control Motor Driver

Adjust only if a satisfactory result is not obtained in "(1) Offset Adjustment of Control Motor Driver". This adjustment is made by changing the value of the fixed resistors on the Logic P.C.B.

Note: The value of voltage is typical value.

(a) Observation Point of Reference Voltage

Observe the each voltage at the sliding contact of the Cam Control Volume VR405 (10 kΩ) in stop, fast (FF or REW), pause, record and playback modes.

(b) Reference Voltage

Reference voltage at the sliding contact of VR405 (Cam Control Volume) in each mode is as follows:

Mode	Reference Voltage (Typical Value)
Stop	3.0 V
Fast (FF/REW)	1.3 V
Pause	-2.8 V
Play	-5.4 V

-1.7 V ± 0.25 V
-2.6 V ± 0.4 V

(c) Resistors for Adjustment

Mode	Ref. No.	Typical Value
Stop	R461	9.1 kΩ (F)
Fast (FF/REW)	R462	4.32 kΩ (F)
Pause	R445	287 kΩ (F)
Play	R443	174 kΩ (F)

(d) Adjustment Procedures

1) Press the Stop Switch to set the N-680ZX in stop mode.

Adjust the value of R461 to obtain 3.0 V (±0.6 V) at the sliding contact of VR405.

Note: When R461 is adjusted, the reference voltage in fast (FF or REW) mode is changed. Therefore, re-check of the reference voltage in fast (FF or REW) mode is required. If the reference voltage is out of the range, re-adjustment of R462 according to next step 2) is necessary.

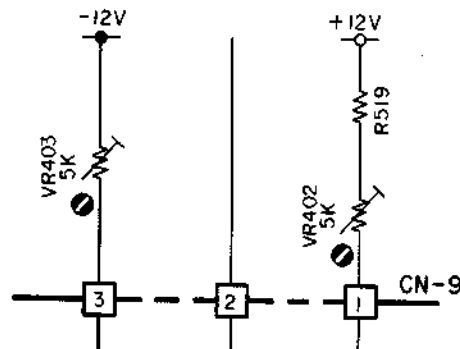

Fig. 4.2

- 2) Set the N-680ZX in FF mode, then adjust the value of R462 so that the voltage of VR405 will become lower by 1.7 V (± 0.25 V) than in stop mode.
- 3) Press the Pause Switch to set the N-680ZX in pause mode.
Adjust the value of R445 to obtain -2.8 V ($+0.4$, -0.15 V) at the sliding contact of VR405.
- 4) Set the N-680ZX in playback mode, then adjust the value of R443 so that the voltage of VR405 will become lower by 2.6 V (± 0.4 V) than in pause mode.

(3) Cam Timing Adjustment

- (a) Remove the wires from the Control Motor Terminals to set the motor open.
- (b) Without loading a cassette tape and with pressing the Record Protecting Switch with your finger tip, press the Record and Play Switches to set the N-680ZX in record mode.
- (c) Turn the Cam and bring the "PY" mark toward the pointer by hand. Reel Motor will rotate before the "PY" mark reaches the pointer. Adjust the value of R483 and R484 so that the voltage at sliding contact of VR405 becomes -3.6 V (± 0.3 V) when Reel Motor starts rotation.
- (d) Observe the mute signal at the Q418 collector. Turn the Cam referring to above step (c) and check to insure that the voltage at the sliding contact of VR405 is -3.8 V (± 0.3 V) when mute is released (mute signal changes from H to L).
(This voltage is determined by the adjustment of R483 and R484 in above step (c).)
- (e) Observe the $\overline{\text{Rec}}$ signal at the Q417 collector. Turn the Cam referring to above step (c) and adjust the value of R488 to obtain -2.1 V (± 0.4 V) at the sliding contact of VR405 when $\overline{\text{Rec}}$ signal changes from H to L (bias oscillation will begin).
- (f) Upon completion of the above adjustment, re-connect wires to the motor terminals.

4.2. Tape Speed Adjustment

(1) Standard Speed (1-7/8 ips)

- (a) Remove the Top Cover.
- (b) Connect a Frequency Counter to Output Jack.
- (c) Load a 3 kHz Speed Wow/Flutter Tape (DA09006A) and play it back.
- (d) Referring to Fig. 4.3, adjust the Tape Speed Adjustment Volume VR407 on the Speed Cal. P.C.B. to obtain 3,000 Hz on the Frequency Counter.

(2) Half-Speed (15/16 ips)

- (a) Remove the Top Cover.
- (b) Connect a Frequency Counter to Output Jack.
- (c) Load a 3 kHz Speed Wow/Flutter Tape (DA09049A) and play it back.
- (d) Referring to Fig. 4.3, adjust the Tape Speed Adjustment Volume VR408 on the Speed Cal. P.C.B. to obtain 3,000 Hz on the Frequency Counter.

CCW: Motor drives slowly.

CW: Motor drives fast.

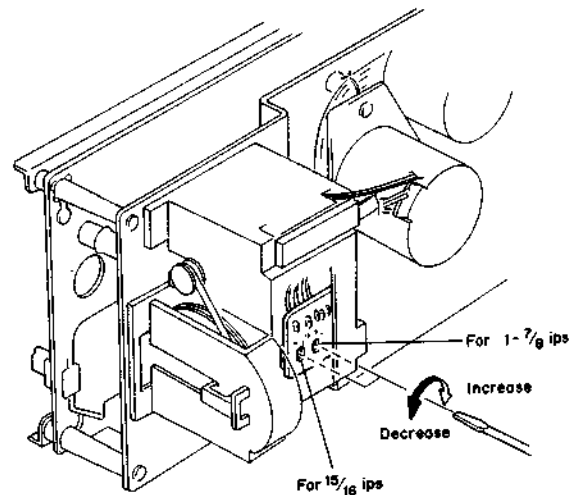

Fig. 4.3

4.3. Record Head and Playback Head Tilt Adjustment

Note: On items 4.3–4.9, please refer to Fig. 4.4 flow chart.

Refer to Figs. 4.5 and 4.6.

- (1) Load a Tilt Check Gauge M-9039 (DA09039A) in the N-680ZX.
- (2) Clip the grounding terminal of the Tilt Check Gauge with one end of the cord with clip, and the other end to the chassis of the N-680ZX.
- (3) Remove both of the Height Gears.
- (4) Set the N-680ZX in play mode. Check to insure whether the Beacons Playback Head "Upper" or "Lower" and Record Head "Upper" or "Lower" are illuminating. In order not to give damages onto the head surfaces, push both of slide knobs of the Gauge to the direction of arrow marks, then return it to the original place to be in contact with record head and playback head surfaces after play mode is se-

curely locked.

- (5) Check to insure freedom from contact between the Gauge and pad lifter.
- (6) Beacon Playback Head "Lower" will light on when height adjustment screw (P) turned clockwise but Playback Head "Upper" when counterclockwise. Adjust so that both "Upper" and "Lower" will light on even when you move the slide knob to the direction of an arrow mark and then return it to the original place.
- (7) Same procedures will apply to the Beacons Record Head "Upper" and "Lower", except for the height adjustment screw (R).
- (8) Set the N-680ZX in stop mode and fit both of the serrated height gears. Then set the N-680ZX again in play mode and insure all of the 4 Beacons are illuminating. If not, (3) through (7) will have to be repeated till satisfactory results are obtained.

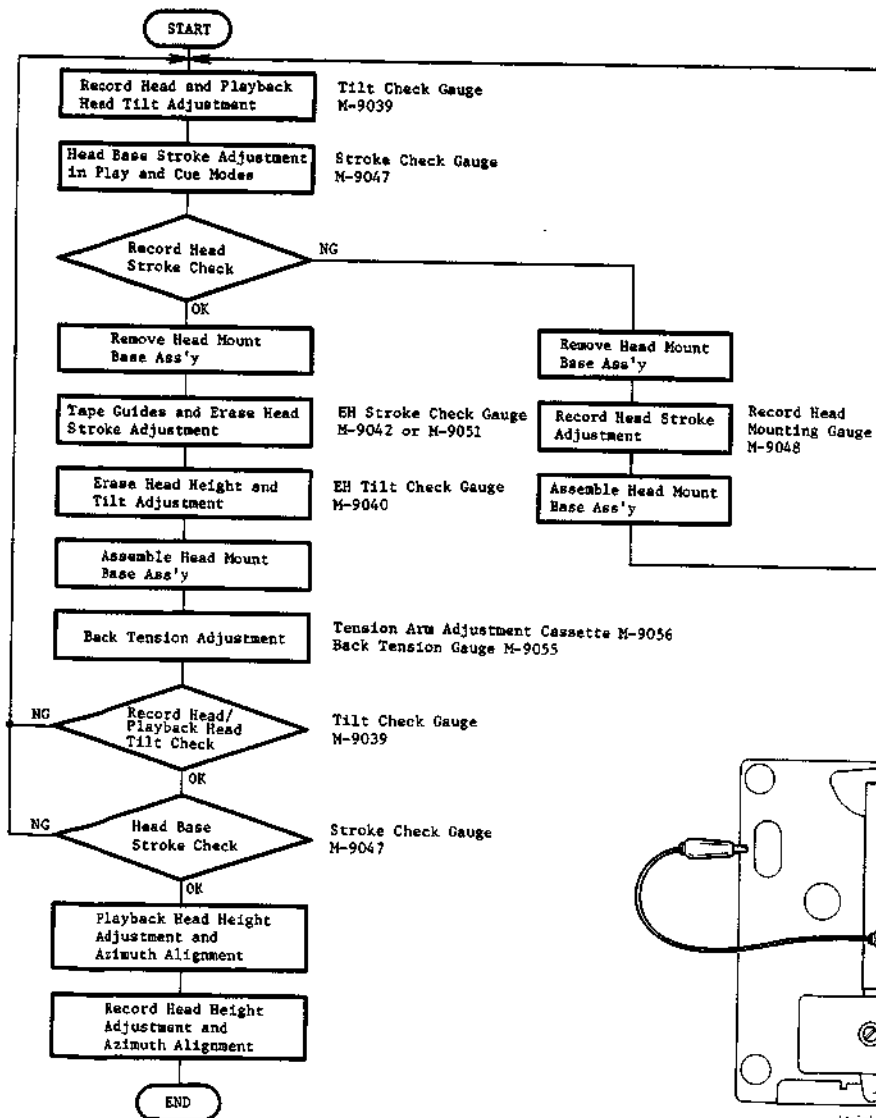

Fig. 4.4

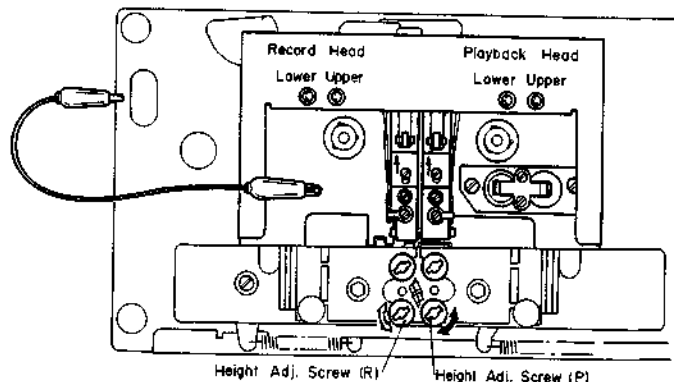

Fig. 4.5

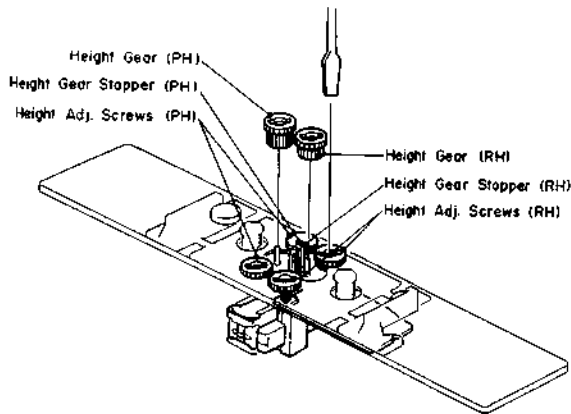

Fig. 4.6

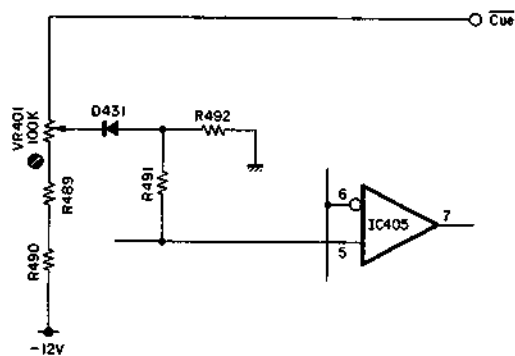

Fig. 4.8

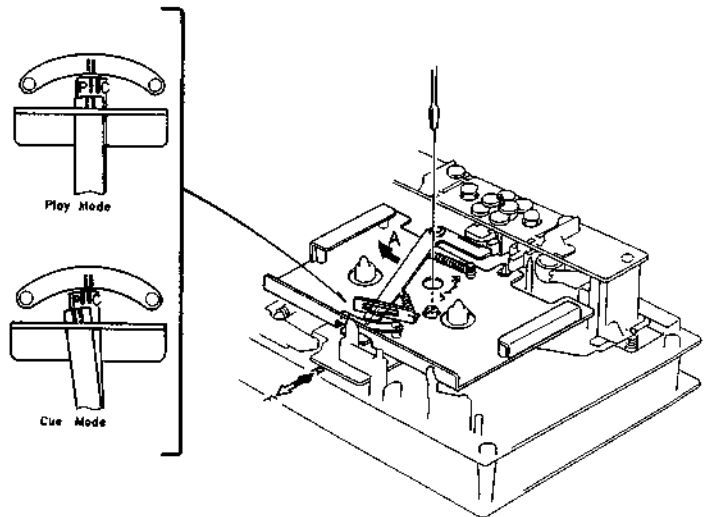

Fig. 4.7

4.4. Head Base Stroke Adjustment in Play and Cue Modes

Note: Before you conduct this adjustment, adjust with a "Tilt Check Gauge" to insure freedom from tilt on the playback head and record head.

(1) Head Base Stroke Adjustment in Play Mode

Refer to Fig. 4.7.

- Load a Stroke Check Gauge M-9047 (DA09047A) in the N-680ZX.
- Move Record Head Indicator and Playback Head Indicator to the direction of arrow mark "A" with your finger tip and then set the N-680ZX in play mode. Then slowly release the Indicators and insure whether each of the Indicators is in contact with record and playback heads.
- Check to insure whether the "P" pointer on the Playback Head Indicator locates between the 2 lines on the Indicator Plate.
- If the playback head stroke is noted to be misaligned, adjustment can be made by moving the stroke adjuster assembled in the head base assembly (either forwardly or backwardly).
- Check to insure whether the "P" pointer on the Playback Head Indicator locates between the 2 lines on the Record Head Indicator, thus check can be made on record head stroke.

- If the record head stroke is noted to be misaligned, adjustment can be made with a Record Head Mounting Gauge M-9048 (DA09048A).

(2) Head Base Stroke Adjustment in Cue Mode

Refer to Fig. 4.8.

- Load a Stroke Check Gauge M-9047 (DA09047A) in the N-680ZX.
- Move Record Head Indicator and Playback Head Indicator to the direction of arrow mark "A" with your finger tip and then set the N-680ZX in cue mode (F.F. and Pause). Then slowly release the Indicators and insure whether each of the Indicators is in contact with record and playback heads.
- Check to insure whether the "C" pointer on the Playback Head Indicator locates between the 2 lines on the Indicator Plate.
- If the playback head stroke is noted to be misaligned, adjust VR401 on the Logic P.C.B. Ass'y till satisfactory results are obtained.
- After completion of the Head Base Stroke Adjustment, check to insure accuracy of the Head Base Stroke Adjustment in play mode. If the above are inaccurate, items (1) and (2) will have to be repeated till satisfactory results are obtained.

4.5. Tape Guides Adjustment and Erase Head Stroke Adjustment

Remove Head Mount Base Ass'y referring to item 2.30. Refer to Figs. 4.9 and 4.10.

(1) Supply Tape Guide Height Adjustment

- (a) Load an EH Stroke Check Gauge M-9042/M-9051 in the N-680ZX.
- (b) Set the N-680ZX in play mode.
- (c) Slide the Supply Tape Guide Check Bar down against the supply tape guide, thus check can be made on supply tape guide height.
- (d) If the supply tape guide is misaligned, the Supply Tape Guide Check Bar will not come into the supply tape guide. If such is noted, turn to adjust the height adjustment nut A till the Supply Tape Guide Check Bar is accepted by the supply tape guide.
- (e) If the above are insured, set the N-680ZX in pause mode, then in play mode to see whether adjustments are appropriately made. If not, (b) through (e) will have to be repeated till satisfactory results are obtained.

(2) Take-up Tape Guide Height Adjustment

- (a) Load an EH Stroke Check Gauge M-9042/M-9051 in the N-680ZX.
- (b) Set the N-680ZX in play mode.
- (c) Slide the Take-up Tape Guide Check Bar down against the take-up tape guide, thus check can be made on take-up tape guide height.
- (d) If the take-up tape guide is misaligned, the Take-up Tape Guide Check Bar will not come into the take-up tape guide. If such is noted, turn to adjust the height adjustment nut B till the Take-up Tape Guide Check Bar is accepted by the take-up tape guide.
- (e) If the above are insured, set the N-680ZX in pause mode, then in play mode to see whether adjustments are appropriately made. If not, (b) through (e) will have to be repeated till satisfactory results are obtained.

(3) Erase Head Stroke Adjustment

- (a) Load an EH Stroke Check Gauge M-9042/M-9051 in the N-680ZX.
- (b) Set the N-680ZX in play mode, thus check can be made on erase head stroke through the EH Stroke Indicator.
- (c) Check to insure whether the erase head surface is aligned with red line on the EH Stroke Indicator. If not, adjust the erase head stroke by loosening 2 screws that assembled erase head and erase head plate.
- (d) After completion of adjustment, 2 pcs. of screws shall be locked with lock tight paint.

Note:

EH Stroke Check Gauge M-9042 (DA09042A) should be used for the Models serial Nos. from A11601001 to A11603009, and EH Stroke Check Gauge M-9051 (DA-09051A) is for the Models bearing serial No. A11603010 and greater.

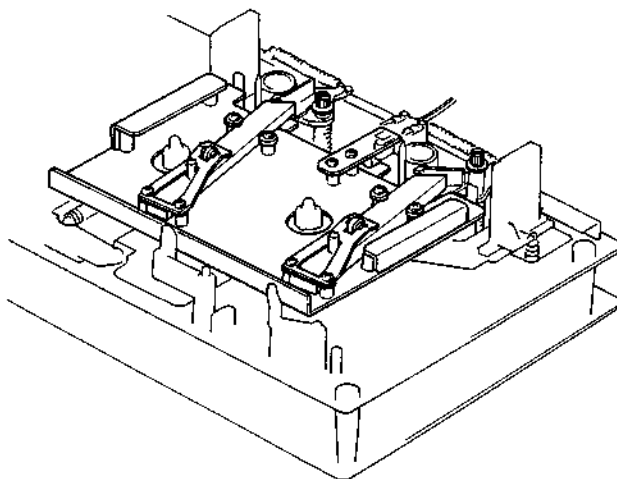

Fig. 4.9

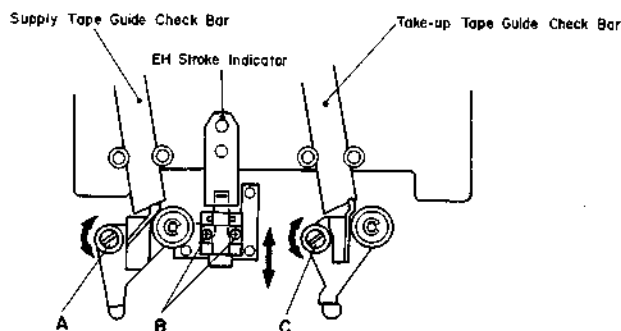

Fig. 4.10

4.6. Erase Head Height and Tilt Adjustment

Refer to Figs. 4.11 and 4.12.

- (1) Remove Head Mount Base Ass'y referring to item 2.30.
- (2) Load an EH Tilt Check Gauge M-9040 (DA09040A) in the N-680ZX.
- (3) Set the N-680ZX in stop mode.
- (4) Check to insure whether one of the 3 Beacons is illuminating. Look down the mirror as shown by an arrow mark and slowly turn the Screw "Height" counterclockwise (or clockwise) so that the two horizontal lines on the mirror will become superposed on the line (in different color) of the erase head, and check to insure whether Beacon "1" is illuminating.

- (5) Turn Screw "Tilt" counterclockwise (or clockwise) to light on Beacon "2". Excessive turning will cause the Beacon "1" to light off. Adjustments of Screw "Tilt" will therefore be conducted till both of the Beacons "1" and "2" illuminate.
- (6) Turn Screw "Azimuth" counterclockwise (or clockwise) to light on Beacon "3". Excessive turning will cause either Beacon "1" or "2" to light off, and therefore adjust with Screw "Azimuth" until all of the 3 Beacons "1", "2" and "3" illuminate.

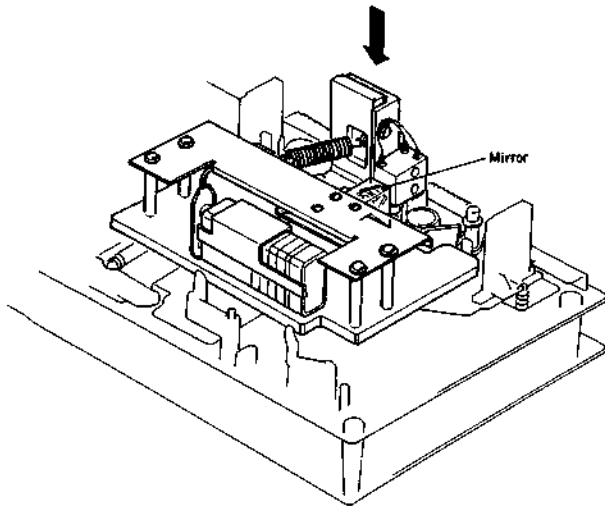

Fig. 4.11

- (7) Check to insure whether the horizontal line on the mirror corresponds to that on the erase head. If not, (4) through (7) will have to be repeated till satisfactory results are obtained.
- (8) After completion of adjustment, 3 pcs. of screws shall be locked with lock tight paint.

Note: Before use of this gauge, check to insure freedom from dust or dirt, or overflow in the groove of the erase head surface.

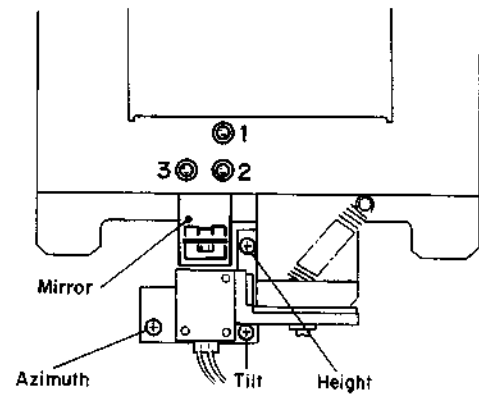

Fig. 4.12

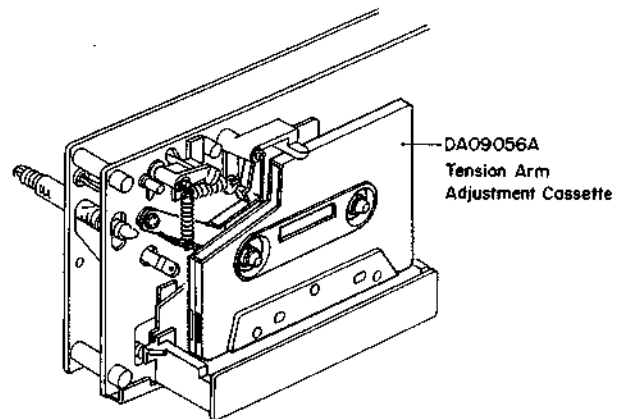

Fig. 4.13

4.7. Back Tension Adjustment

Note: This adjustment is required for the Models bearing serial Nos. A11606264 and greater.

Refer to Figs. 4.13 - 4.16.

- (1) Load the Tension Arm Adjustment Cassette (DA 09056A) referring to Fig. 4.13.
- (2) Set the Cassette Deck in play mode.
- (3) Bend the Back Tension Arm with pliers so that the gap between the Cassette Holding Spring assembled with the Head Base Ass'y and the Back Tension Arm becomes 0.5 mm as shown in Fig. 4.14. Do not bend the pointed end of the Back Tension Arm.

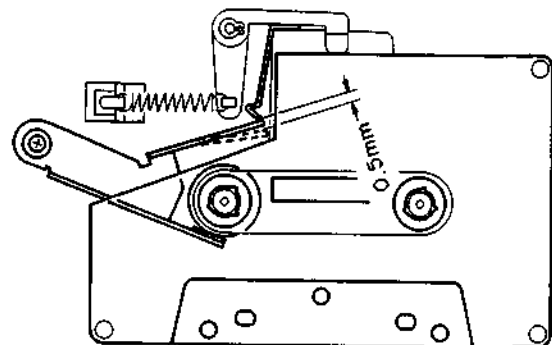

Fig. 4.14

- (4) Set the Cassette Deck in stop mode, and remove the Tension Arm Adjustment Cassette (DA09056A), then set the Cassette Deck in cue mode.

In cue mode, check to insure that the gap is found between the Supply Reel Hub B Ass'y and the Felt of Back Tension Ass'y as shown in Fig. 4.15.

- (5) Load the Back Tension Gauge (DA09055A).

- (6) Set the Cassette Deck in play mode and read the torque value of Back Tension Gauge.

If the value is in a range of 6 g-cm to 10 g-cm, adjustment is not necessary. If not, change the installation point of the Back Tension Spring as shown in Fig. 4.16, and obtain the torque of 7 g-cm to 9 g-cm range.

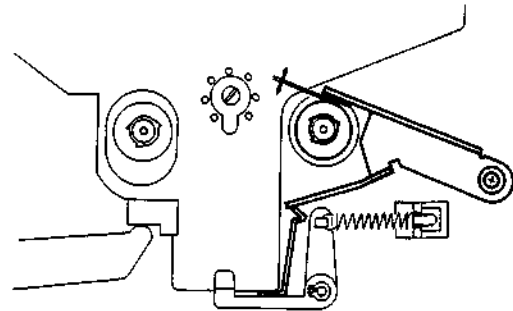

Fig. 4.15

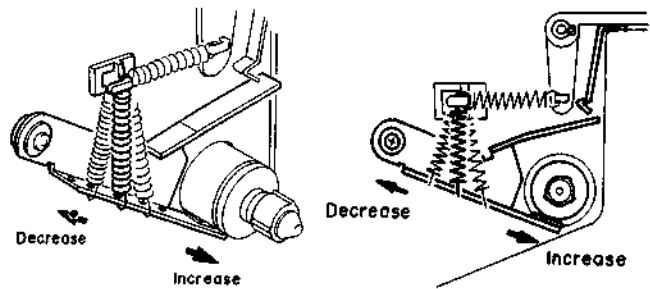

Fig. 4.16

4.8. Playback Head and Record Head Height Adjustment and Azimuth Alignment

(1) Playback Head Height Adjustment and Azimuth Alignment

Refer to Fig. 4.17.

- Set the Monitor Switch to the Tape position, then connect a VTVM to the Output Jacks.
- Load a 1 kHz Track Alignment Tape (DA09007A), then set the N-680ZX in play mode.
- Turn the PH Height Gear until the outputs of both channels become minimum.
- Load a 15 kHz Azimuth Tape (DA09004A), then set the N-680ZX in play mode.
- Turn the PH Azimuth Alignment Screw until the outputs of both channels become maximum.
- Repeat above steps (b) through (e) one or two times to obtain optimum performance.

(2) Record Head Height Adjustment and Azimuth Alignment

Refer to Figs. 4.17 - 4.20.

- (a) Set the N-680ZX in stop mode.

Turn the Azimuth Motor in the Azimuth Alignment Motor Ass'y by hand so that the Alignment Indicator corresponds to the pointer of the Azimuth Alignment Motor Ass'y as shown in Fig. 4.18.

Remove the Azimuth Alignment Wire by pulling out from the Azimuth Alignment Motor Ass'y. In this case, do not move the Slide Lever of the Azimuth Alignment Wire. Short both leads of capacitor C903 on the Auto Azimuth P.C.B. Ass'y with a jumper wire.

- Set the Monitor Switch to the Tape position, then connect a VTVM to the Output Jacks.
- Load a Reference SX Tape (DA09025A). Set the Eq. Switch to the 70 μ s position and the Tape Switch to the SX position. Then set the N-680ZX in record and play mode.
- Set the Display Switch to the Cal. position, then turn the RH Height Gear until the outputs of both channels become maximum.
- Feed in 15 kHz (-20 dB), then set the N-680ZX in record and play mode. Turn the RH Azimuth Alignment Screw until the outputs of both channels become maximum.
- Repeat above steps (d) and (e) one or two times to obtain optimum performance.
- After completion of the above adjustments, perform the following electrical adjustments first at standard tape speed, then at half tape speed.

Note: Use the same side of the same tape used in the above steps.

(1) Standard Speed (1-7/8 ips):

- Set the Monitor Switch to the Tape position and the Display Switch to the Cal. position, then set the N-680ZX in record and play mode.
- Adjust VR404 on the Logic P.C.B. Ass'y so that the cursors are coincident with the rightmost edges of the main displays on the FL Level Indicators.
- Adjust VR901 on the Auto Azimuth P.C.B. Ass'y so that the Azimuth Motor stops its rotation.

- (2) Half-Speed (15/16 ips):
- Set the Tape Selector to the 15/16 ips position.
 - Feed in 15 kHz (-20 dB), then set the N-680ZX in record and play mode. Turn the RH Azimuth Alignment Screw until the outputs of both channels become maximum.
 - Set the Monitor Switch to the Tape position and the Display Switch to the Cal. position, then set the N-680ZX in record and play mode.
 - Adjust VR405 on the Logic P.C.B. Ass'y so that the cursors are coincident with the rightmost edges of the main displays on the FL Level Indicators.
 - Adjust VR902 on the Auto Azimuth P.C.B. Ass'y so that the Azimuth Motor stops its rotation.
- (h) Set the N-680ZX in stop mode.

Mount the Azimuth Alignment Wire on the Azimuth Alignment Motor Ass'y referring to Fig. 4.19. (Correct the position of the Slide Lever of the Azimuth Alignment Wire by sliding by hand, then insert the Slide Lever into the receptacle of the Azimuth Alignment Motor Ass'y.)

Remove the shorting jumper wire from C903 on the Auto Azimuth P.C.B. Ass'y.

- After completion of the above adjustments, record 400 Hz tone to the same portion of both sides A and B of the tape.
- Immerse the recorded tape in a magnetized developing solution. In turn, check to insure that the recording head tracks across the center are separated with a distance of 0.55 to 0.75 mm (typically 0.65 mm) as illustrated in Fig. 4.20.

Note: Liquid for tape magnetized development solution

"MAGNA-SEE SOUND CRAFT a product of CBS RECORDS a division of Columbia Broadcasting System, Inc., Danbury, Conn. 06810 U.S.A., or equivalent".

After development, clean the tape otherwise pressure rollers and heads will become dirty.

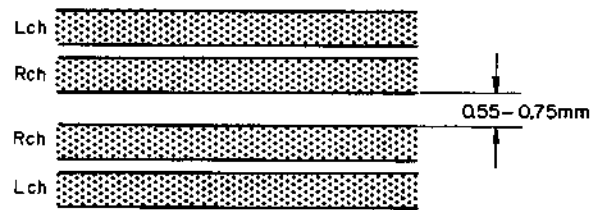

Fig. 4.20

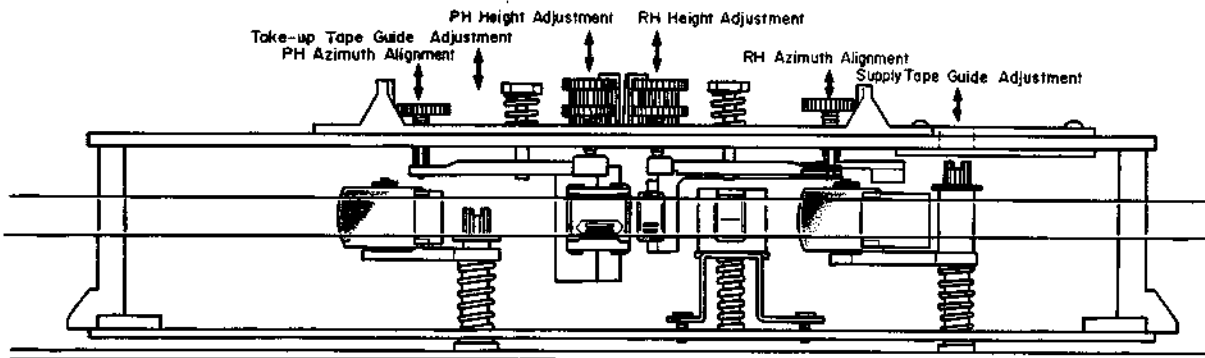

Fig. 4.17

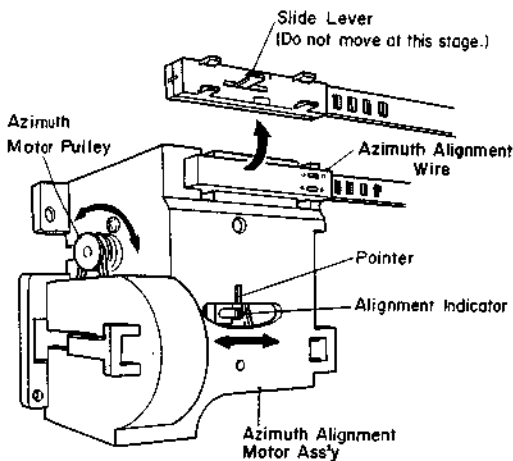

Fig. 4.18

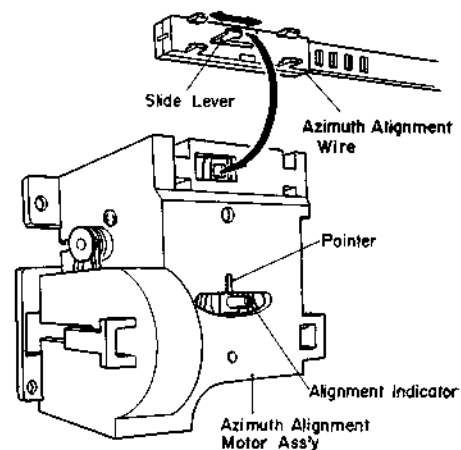

Fig. 4.19

4.9. Record Head Stroke Adjustment

Refer to Figs. 4.21 and 4.22.

Note: This adjustment will be required only to insure freedom from misalignment of the record head stroke in the record head stroke check mode.

- (1) Check the accuracy of the record head stroke.
- (2) Remove Head Mount Base Ass'y referring to item 2.30.
- (3) Remove the record head assembly.
- (4) Adjustment of Record Head Mounting Gauge M-9048 (DA09048A)
 - (a) Mount the Block B onto the Mounting Gauge Plate.
 - (b) Loosen the 2 screws fixing the Block A.
 - (c) As shown in Fig. 4.21 hold the Gauges (3.05 mm and either one of 0.05, 0.15, 0.2, 0.25, 0.3 or 0.35 mm thickness) between the Block A and Block B, fix the Block A with screw, pushing the Block A to the 2 guide pins.
- (5) Remove the Block B from the Mounting Gauge Plate.
- (6) As shown in Fig. 4.22, mount the R-8L record head assembly onto the Mounting Gauge Plate, then check the location of the R-8L record head surface. (If record head contacts to the Block C, loosen 2 pcs. of screws that assembled record head and R-8L record head assembly, then place the R-8L record head assembly onto the Plate.)
- (7) Remove the R-8L record head assembly from the Mounting Gauge Plate.
- (8) Readjustment of Record Head Mounting Gauge M-9048 (DA09048A)
 - (a) Mount the Block B onto the Mounting Gauge Plate.
 - (b) Loosen the 2 screws fixing the Block A.
 - (c) As shown in Fig. 4.21 hold the Gauges (3.05 mm and either one of 0.05, 0.15, 0.2, 0.25, 0.3 or 0.35 mm thickness) between the Block A and Block B, fix the Block A with screw, pushing the Block A to the 2 guide pins.
- (9) Remove the Block B from the Mounting Gauge Plate.
- (10) Mount the R-8L record head assembly onto the Mounting Gauge Plate.
- (11) As shown in the Fig. 4.22, loosen the R-8L record head with 2 pcs. of screws onto the record head plate. As the location of the Block A is secured by the item (8)-(c), push the record head to the directions A and B, then tighten 2 pcs. of screws.
- (12) Check to insure freedom from gap between the Block C and record head surface, then tighten the 2 pcs. of screws on the record head plate with lock tight paint.
- (13) Assemble the record head assembly to the head mount base assembly.
- (14) Assemble the head mount base assembly to the mechanism assembly.
- (15) Check the record head stroke.

If the above are inaccurate, items (1) through (15) will have to be repeated till satisfactory results are obtained.

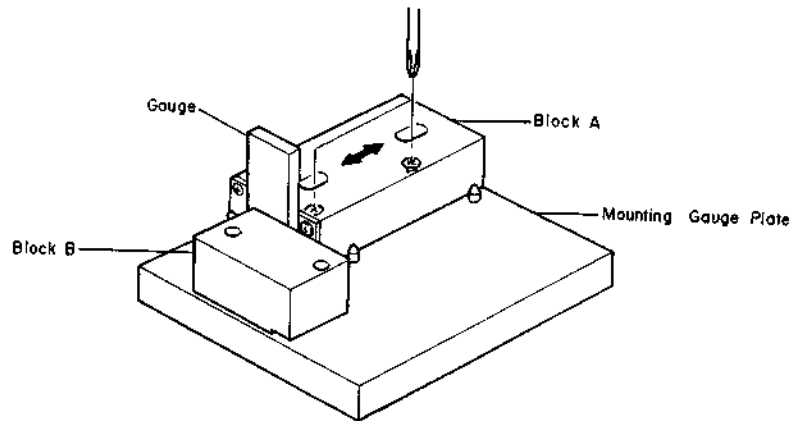
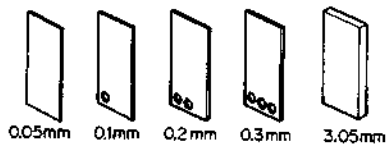

Fig. 4.21

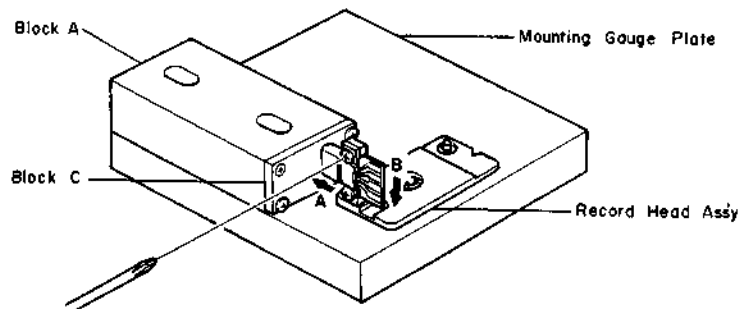

Fig. 4.22

4.10. Tape Travelling Adjustment

The adjustment shall be made with a modified version of the current type EXII C-90 as shown in Fig. 4.23 (error will be made if a current type Tape Travelling Cassette (DA09011A) should be used for this purpose).

While modifying an EXII C-90, the tape guides in the cassette housing shall be kept protected to avoid tilt. Check shall be made in the following procedures:

- (1) An EXII C-90 Tape thus modified shall be loaded onto the N-680ZX.
- (2) Release the back-tension (rotate the Supply Reel and feed out some length of tape) and set the N-680ZX in play mode.
- (3) In this juncture, check to insure whether the tape is free from waving or slippage from the tape guide.
- (4) When the modified EXII C-90 is played back, check to insure whether the tape is freedom from waving from head surface or at pressure rollers.
- (5) If either of waving or slippage from the tape guide should be noted, adjustments of "4.3. Record Head and Playback Head Tilt Adjustment", "4.4. Head Base Stroke Adjustment", "4.5. Tape Guides Adjustment and Erase Head Stroke Adjustment", "4.6. Erase Head Height and Tilt Adjustment", "4.7. Back Tension Adjustment", "4.8. Playback Head and Record Head Height Adjustment and Azimuth Alignment", "4.9. Record Head Stroke Adjustment", etc. will be required.

As a case may be, the said waving or slippage may have been caused from defective Supply Pressure Roller Ass'y or Take-up Pressure Roller Ass'y without parallel contact with capstans. If such are noted, the Pressure Roller Assemblies will have to be replaced.

Further, excessively weak take-up torque or strong take-up torque may cause defective tape travelling.

The N-680ZX is intended to be an adjustment-free Model, however if the similar matters as above should be noted, please replace the Reel Hub Ass'y to obtain appropriate take-up torque.

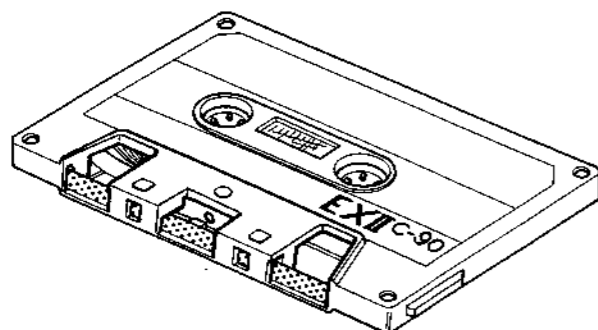

Fig. 4.23

4.11. Flywheel Holder Adjustment

- (1) Refer to Fig. 4.24.

Tighten the Thrust Screws until the gap between the Flywheel Assemblies and Thrust Screws becomes minimized when both of the Capstan Shafts are moved backwardly and forwardly (the Thrust Springs between the Capstan Flanges and Flywheel Thrust Caps are in a flat state).

Excessive tightening of the Thrust Screws however will give damages on the Flywheel Assemblies, to which careful attention is invited.

- (2) Return the Thrust Screws by 1/2 turn.
- (3) Fixing the Thrust Screw with a screwdriver, lock the Lock Nut.
- (4) Apply a quantity of lock tight paint to the Thrust Screws.

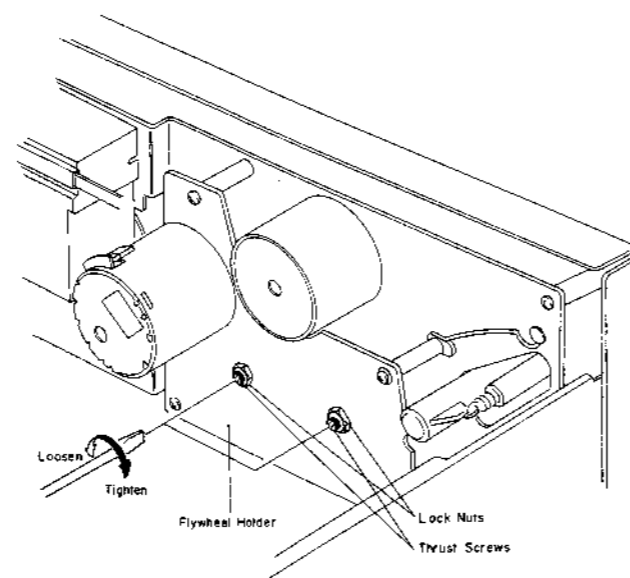

Fig. 4.24

4.12. Lubrication

N-680ZX is a lubrication-free cassette deck except when parts are replaced. Apply the following lubricant for each replaced part:

- (1) LAUNA #100
Capstan Shaft
Pressure Roller Shaft
Thrust Cap
- (2) FLOIL GB-TS-1
Reel Hub Shaft
Thrust portion on the Capstan Shaft
FLOIL GB-TS-1, made by Kanto Chemicals Co., Ltd., in Japan.
- (3) Silicon Oil #3000CST
Air Damper Piston

Note: Excessive lubrication may cause defective damper action as the 0.2φ hole at the end of the cylinder may be filled with oil.



6. ELECTRICAL ADJUSTMENTS AND MEASUREMENTS

6.1. Adjustment and Measurement Instructions

Note: Electrical adjustment should be performed after mechanical adjustment is completed.

STEP	ITEM	SIGNAL SOURCE	OUTPUT CONNECTION	MODE	ADJUSTMENT	REMARKS
1	Tape Speed	3 kHz Speed and Wow/Flutter Tapes (DA09006A and DA09049A)	Frequency Counter to OUTPUT Jacks	Playback	Speed Cal. P.C.B. VR407 VR408	<ol style="list-style-type: none"> Standard Speed (1-7/8 ips): Adjust VR407 to obtain 3 kHz \pm 0.5%. Half-Speed (15/16 ips): Adjust VR408 to obtain 3 kHz \pm 0.5%.
2	Tone Calibration	Test Tone 400 Hz	VTVM to TP101, TP201 on the Main P.C.B.	Monitor SW – Source Display SW – CAL	Main P.C.B. VR301 Switch P.C.B. VR161	<ol style="list-style-type: none"> Set the Display Switch to CAL. Turn output level control fully clockwise (maximum position). Adjust VR301 to obtain 100 mV \pm 0.2 dB on the VTVM at TP201 (output will be 1 V (0 dB)). Adjust VR161 to obtain the same level as Right channel on the VTVM at TP101.
3	FL Indicator Level and Dynamic Range	400 Hz (0 dB/-20 dB) to INPUT Jacks	Frequency Counter to IC907-10 pin on the Indicator P.C.B. C and VTVM to TP101, TP201 on the Main P.C.B.	Monitor SW – Source Display SW – VU or P. Hold	Indicator P.C.B. C VR901 Switch P.C.B. VR701, VR801	<ol style="list-style-type: none"> Remove the FL Indicator Ass'y from the Front Chassis, then disassemble the FL Indicator Ass'y itself. Adjust VR901 to obtain 25.6 kHz clock oscillation frequency on the Frequency Counter. Assemble the FL Indicator Ass'y, then install it to the Front Chassis. Adjust the input level control to obtain 100 mV at TP101 (TP201) on the VTVM. Adjust VR701 (VR801) so that the FL level indicator displays 0 dB. Decrease input signals by 20 dB to obtain 10 mV at TP101 (TP201) on the VTVM, then adjust VR901 so that the FL level indicator displays -20 dB. Repeat steps 4 through 6 till satisfactory results are obtained.
4	MPX Filter	19 kHz \pm 100 Hz to INPUT Jacks	VTVM to OUTPUT Jacks	Monitor SW – Source Display SW – VU or P. Hold Dolby NR SW – OUT/MPX	Switch P.C.B. L162, L262	<ol style="list-style-type: none"> Turn output level control fully clockwise (maximum position). Adjust input level control to obtain 1 V on the VTVM. Set the Dolby NR Switch to MPX position, then adjust L162 (L262) to obtain minimum reading on the VTVM (minimum reading will be less than -30 dB).
5	Playback Head Track Alignment	1 kHz Track Alignment Tape (DA09007A)	VTVM to OUTPUT Jacks	Playback Monitor SW – Tape Display SW – VU or P. Hold Eq. SW – 70 μ s Dolby NR SW – OUT Tape Speed SW – 1-7/8 ips	Playback Head Height Adj. Screw	Adjust the Playback Head Height Adj. Screw to obtain minimum reading of both L and R channels on the VTVM. See "Playback Head Height Adjustment and Azimuth Alignment" in item 4.8.
6	Playback Head Azimuth Alignment	15 kHz Azimuth Tape (DA09004A)	VTVM to OUTPUT Jacks	Playback Monitor SW – Tape Display SW – VU or P. Hold Eq. SW – 70 μ s Dolby NR SW – OUT Tape Speed SW – 1-7/8 ips	Playback Head Azimuth Alignment Screw	Adjust the Playback Head Azimuth Alignment Screw to obtain maximum reading of both L and R channels on the VTVM. See "Playback Head Height Adjustment and Azimuth Alignment" in item 4.8. Note: Repeat steps 5 and 6 one or two times to obtain optimum performance.
7	Playback level	400 Hz Level Tape (DA09005A)	VTVM to TP101, TP201 on the Main P.C.B.	Same as above	Main P.C.B. VR101, VR201	Adjust VR101 (VR201) to obtain 100 mV on the VTVM or 0 dB on the FL level indicators.
8	Playback Frequency Response Adjustment at Standard Speed (1-7/8 ips)	400 Hz Level Tape (DA09005A) 10 kHz PB Frequency Response Tape (DA09003A) 15 kHz PB Frequency Response Tape (DA09002A) 20 kHz PB Frequency Response Tape (DA09001A)	VTVM to OUTPUT Jacks	Playback Monitor SW – Tape Display SW – VU or P. Hold Eq. SW – 70 μ s Dolby NR SW – OUT Tape Speed SW – 1-7/8 ips	Main P.C.B. R112, R212	<ol style="list-style-type: none"> Load the 400 Hz level tape and play it back. Adjust the output level control to a certain level (for example 0 dB). Load the 10 kHz, 15 kHz and 20 kHz PB frequency response tapes and adjust the playback head azimuth to give maximum levels on the VTVM with each tape. Short R112 (R212) to obtain the following levels against 400 Hz level tape. Refer to Fig. 6.5. 10 kHz: -20 dB -1 dB to +2 dB 15 kHz: -20 dB -1 dB to +3 dB 20 kHz: -20 dB -1 dB to +4 dB Conduct step 6 "Playback Head Azimuth Alignment". If above is not sufficient, refer to "Playback Frequency Response Adjustment" in item 6.2.

STEP	ITEM	SIGNAL SOURCE	OUTPUT CONNECTION	MODE	ADJUSTMENT	REMARKS
9	Playback Frequency Response Check at Half-Speed (15/16 ips)	400 Hz Level Tape (DA09005A) 10 kHz PB Frequency Response Tape (DA09003A) 15 kHz PB Frequency Response Tape (DA09002A) 20 kHz PB Frequency Response Tape (DA09001A)	VTVM to OUTPUT Jacks	Playback Monitor SW – Tape Display SW – VU or P. Hold Eq. SW – 120 μs Dolby NR SW – OUT Tape Speed SW – 15/16 ips		1. Load the 400 Hz level tape and play it back. Adjust the output level control to a certain level (for example 0 dB). 2. Load the 10 kHz, 15 kHz and 20 kHz PB frequency response tapes and adjust the playback head azimuth to give maximum levels on the VTVM with each tape. Check to insure the following levels against 400 Hz level tape. Output frequency will become half as shown in () as the tape speed is half. 10 kHz: (5 kHz) -22 dB -3 dB to 0 dB 15 kHz: (7.5 kHz) -22 dB -3 dB to +1 dB 20 kHz: (10 kHz) -22 dB -3 dB to +2 dB 3. Conduct step 6 "Playback Head Azimuth Alignment".
10	Bias Oscillation Frequency and Erase Current	Connect an additional 0.1 Ω resistor in series to the Erase Head	VTVM and Frequency Counter across the additional 0.1 Ω resistor	Record, Pause Monitor SW – Source Tape SW – ZX Eq. SW – 70 μs Dolby NR SW – OUT	Main P.C.B. T301 R331, R330	1. Adjust T301 to obtain 105 kHz on the frequency counter. 2. Check the erase current by the VTVM. Erase current will be in a range of 310 mA to 400 mA (typically approx. 350 mA). If erase current is not sufficient, increase it by shorting R331 or R330. 3. After completion of the erase current adjustment, recheck the bias oscillation frequency.
11	Record Amplifier Equalizer	23 kHz (-20 dB) to INPUT Jacks	VTVM to CN2-1, CN2-3 on the Main P.C.B.	Record, Pause Monitor SW – Source Display SW – VU or P. Hold Tape SW – ZX Eq. SW – 70 μs Dolby NR SW – OUT Tape Speed SW – 1-7/8 ips	Main P.C.B. L102, L202	1. Remove the bias-cut-jumper from the dip side of the Main P.C.B. 2. Adjust L102 (L202) to obtain peak reading at 23 kHz on the VTVM. 3. Re-solder the bias-cut-jumper.
12	Bias Trap (Record Amp.)	Remove input signals	Same as above	Same as above	Main P.C.B. L103, L203	Adjust L103 (L203) to obtain maximum reading on the VTVM.
13	Bias Trap (Playback Amp.)	Remove input signals	VTVM to OUTPUT Jacks	Same as above	Main P.C.B. L101, L201	Adjust L101 (L201) to obtain minimum reading on the VTVM.

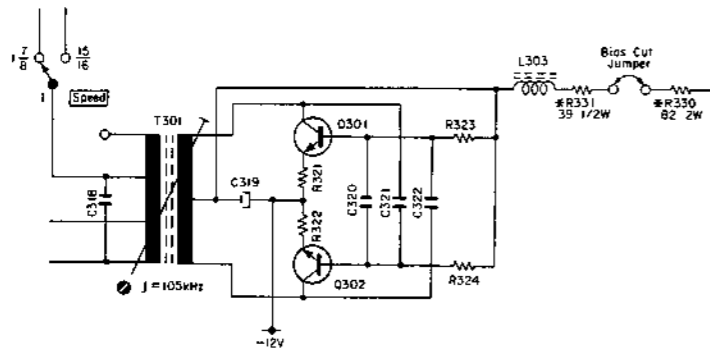

Fig. 6.6 10. Bias Oscillation Frequency and Erase Current

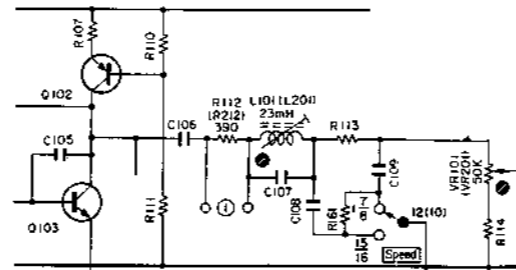

Fig. 6.8 13. Bias Trap (Playback Amp.)

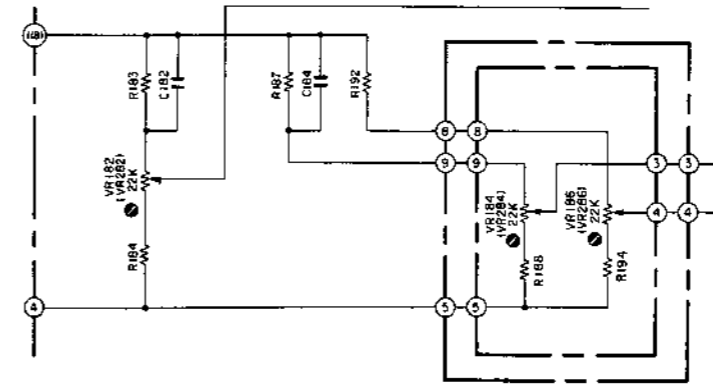

Fig. 6.10 14. Record Head Height and Azimuth

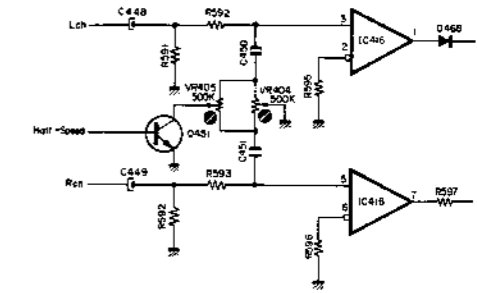
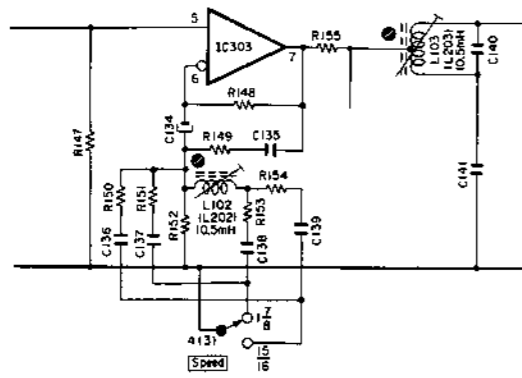

Fig. 6.12 14. Record Head Height and Azimuth



STEP	ITEM	SIGNAL SOURCE	OUTPUT CONNECTION	MODE	ADJUSTMENT	REMARKS
14	Record Head Height Adjustment and Azimuth Alignment	Test Tone 400 Hz or 12.5 kHz (-20 dB) to INPUT Jacks	VTVM to OUTPUT Jacks	Record, Playback Monitor SW - Tape Display SW - CAL/VU or P. Hold Tape SW - SX Eq. SW - 70 μ s Dolby NR SW - OUT Tape Speed SW - 1-7/8 ips/ 15/16 ips	Head Height: Record Head Height Adj. Screw Azimuth Alignment: Record Head Azimuth Alignment Standard Speed (1-7/8 ips): Rec. Cal. P.C.B. (Level) VR183, VR283 Switch P.C.B. (Bias) VR166, VR266 Logic P.C.B. VR404 Auto Azimuth P.C.B. VR901 Half-Speed (15/16 ips): Rec. Cal. P.C.B. (Level) VR184, VR284 Switch P.C.B. (Bias) VR163, VR263 Logic P.C.B. VR405 Auto Azimuth P.C.B. VR902	<ol style="list-style-type: none"> In stop mode, turn the Azimuth Motor by hand so that the Alignment Indicator corresponds to the pointer of the Azimuth Alignment Motor Ass'y as shown in Fig. 4.18. Remove the Azimuth Alignment Wire by pulling out from the Azimuth Alignment Motor Ass'y. (In this case, do not move the Slide Lever of the Azimuth Alignment Wire.) Short both leads of capacitor C903 on the Auto Azimuth P.C.B. Ass'y with a jumper wire. Record Head Height Adjustment: <ol style="list-style-type: none"> Set the Display Switch to CAL. Record signals on the reference SX tape (DA09025A), then play it back. Adjust the Record Head Height Adj. Screw to obtain maximum readings of both channels on the VTVM. Record Head Azimuth Alignment: Perform the following procedures for both standard and half tape speeds. <ol style="list-style-type: none"> Set the Tape Speed Selector to 1-7/8 / 15/16. Set the Display Switch to CAL. Record signals on the reference SX tape (DA09025A), then play it back. Adjust Record Cal. VR183(VR283)/VR184(VR284) to the center position. Adjust Bias VR166(VR266)/VR163(VR263) to obtain maximum reading on the VTVM. Adjust Record Cal. VR183(VR283)/VR184(VR284) to obtain the same reading as the source monitor level on the FL level indicator. Set the Display Switch to VU or P. Hold, then feed in 12.5 kHz (-20 dB). Record signals on the reference SX tape (DA09025A), then play it back. Adjust the Record Head Azimuth Alignment Screw to obtain maximum readings of both channels on the VTVM. Adjust finely VR166(VR266)/VR163(VR263) to obtain the same reading as the source monitor level on the VTVM. Repeat above substeps 2 and 3 one or two times to obtain optimum performance. Set the Display Switch to CAL. Record signals on the reference SX tape (DA09025A), then play it back. Adjust VR404/VR405 so that the cursors are coincident with the rightmost edges of the main displays on the FL level indicators. Adjust VR901/VR902 so that the Azimuth Motor stops its rotation. After completion of above steps, mount the Azimuth Alignment Wire on the Azimuth Alignment Motor Ass'y. Remove the shorting jumper wire from C903 on the Auto Azimuth P.C.B. Ass'y. Check the Auto Azimuth Alignment function as follows for both standard and half tape speeds: <ol style="list-style-type: none"> Set the Tape Speed Selector to 1-7/8 / 15/16. Set the Display Switch to VU or P. Hold. Load a reference tape, then depress the Record Button and Play Button simultaneously to start recording. Change the Display Switch to the CAL. position and check to insure that the play lamp will keep flashing. Set the Display Switch to VU or P. Hold, then feed in 12.5 kHz (-20 dB). Record signals on the reference SX tape (DA09025A), then play it back. Check to insure that the playback level is the same as the source monitor level for both channels. If above is insured, the Auto Azimuth Alignment function is accurate.

STEP	ITEM	SIGNAL SOURCE	OUTPUT CONNECTION	MODE	ADJUSTMENT	REMARKS
15	Record Head Azimuth Phase Adjustment	Test Tone 400 Hz and 15 kHz (-20 dB) to INPUT Jacks	VTVM to OUTPUT Jacks	Record, Playback Monitor SW - Tape Display SW - CAL/VU or P. Hold Tape SW - ZX Eq. SW - 70 μs Dolby NR SW - OUT Tape Speed SW - 1-7/8 ips/ 15/16 ips	Standard Speed (1-7/8 ips): Rec. Cal. P.C.B. (Level) VR181, VR281 Switch P.C.B. (Bias) VR167, VR267 Logic P.C.B. VR404 Half-Speed (15/16 ips): Rec. Cal. P.C.B. (Level) VR182, VR282 Switch P.C.B. (Bias) VR164, VR264 Logic P.C.B. VR405	<ol style="list-style-type: none"> Step 14 "Record Head Azimuth Alignment" should be completely performed. Perform the following adjustment procedures first at standard tape speed, then at half tape speed. <ol style="list-style-type: none"> Set VR405 to the center position. Set the Tape Speed Selector to 1-7/8 / 15/16. Set the Display Switch to CAL. Record signals on the reference ZX tape (DA09037A), then play it back. Adjust Record Cal. VR181(VR281)/VR182(VR282) to the center position. Adjust Bias VR167(VR267)/VR164(VR264) to obtain maximum reading on the VTVM. Set the Display Switch to VU or P. Hold, then feed in 15 kHz (-20 dB). Record signals on the reference ZX tape (DA09037A), then play it back. Adjust Record Head Azimuth Alignment Screw to obtain maximum reading on the VTVM, while adjust Bias VR167(VR267)/VR164 (VR264) to obtain -20 dB ± 0 dB on the VTVM. Set the Display Switch to CAL. Adjust VR404/VR405 so that the azimuth cursors are coincident with the rightmost edges of the main displays on the FL level indicators.
16	Record Level Calibration and Recording Bias Current Adjustment	Test Tone 400 Hz or 400 Hz (0 dB) and 12.5 kHz/15 kHz (-20 dB) to INPUT Jacks	VTVM and Distortion Meter to OUTPUT Jacks	Standard Speed (1-7/8 ips): Record, Playback Monitor SW - Tape Display SW - CAL/VU or P. Hold Tape SW - ZX/SX/EX Eq. SW - 70 μs (ZX/SX) 120 μs (EX) Dolby NR SW - CUT Tape Speed SW - 1-7/8 ips Half-Speed (15/16 ips): Record, Playback Monitor SW - Tape Display SW - CAL/VU or P. Hold Tape SW - ZX/SX/EX Eq. SW - 120 μs Dolby NR SW - CUT Tape Speed SW - 15/16 ips	Standard Speed (1-7/8 ips): Rec. Cal. P.C.B. (Level) ZX: VR181, VR281 SX: VR183, VR283 EX: VR185, VR285 Switch P.C.B. (Bias) ZX: VR167, VR267 SX: VR166, VR266 EX: VR165, VR265 Half-Speed (15/16 ips): Rec. Cal. P.C.B. (Level) ZX: VR182, VR282 SX: VR184, VR284 EX: VR186, VR286 Switch P.C.B. (Bias) ZX: VR164, VR264 SX: VR163, VR263 EX: VR162, VR262	<p>For each tape to be used, perform the Auto Azimuth Alignment operation by depressing Record and Play Buttons simultaneously after setting the Display Switch to CAL.</p> <p>To minimize the influence of interference between each VR, adjustment should be made in the order of ZX, SX and EX. In each tape position, adjust first the following steps at tape speed 1-7/8 ips, then perform at tape speed 15/16 ips. After that re-check the performance at tape speed 1-7/8 ips and 15/16 ips. If satisfactory results are not obtained, re-adjustment at tape speed 1-7/8 ips and 15/16 ips will be required. After completion of adjustment for each tape, re-check the performance.</p> <ol style="list-style-type: none"> Set the Tape Speed Switch to 1-7/8 / 15/16. Set the Display Switch to CAL. Record signals on the reference ZX tape (DA09037A), SX tape (DA09025A), or EXII tape (DA09021A), then play it back. Adjust Record Cal. VR181(VR281)/VR182(VR282) (for ZX), VR183 (VR283)/VR184(VR284) (for SX), or VR185(VR285)/VR186(VR286) (for EXII) to the center position. Adjust Bias VR167(VR267)/VR164(VR264) (for ZX), VR166(VR266)/VR163(VR263) (for SX), or VR165(VR265)/VR162(VR262) (for EXII) to obtain maximum reading on the VTVM. Set the Display Switch to VU or P. Hold, then feed in 15 kHz (-20 dB) (for ZX), or 12.5 kHz (-20 dB) (for SX and EXII). Adjust finely VR167(VR267)/VR164(VR264) (for ZX), VR166(VR266)/VR163(VR263) (for SX), or VR165(VR265)/VR162(VR262) (for EXII) to obtain the same reading as source monitor level on the VTVM. Set the Display Switch to CAL. Adjust Record Cal. VR181(VR281)/VR182(VR282) (for ZX), VR183 (VR283)/VR184(VR284) (for SX), or VR185(VR285)/VR186(VR286) (for EXII) to obtain 0 dB on the FL level indicators. Repeat 6 through 9 as above two or three times to obtain optimum performance. Check whether the total harmonic distortion (T.H.D.) is less than 0.8%/1.5% (for ZX), or 1.0%/2.0% (for SX and EXII). <p>Note: Typical bias current ZX: approx. 3.4 mA SX: approx. 1.5 mA EXII: approx. 0.9 mA</p>

STEP	ITEM	SIGNAL SOURCE	OUTPUT CONNECTION	MODE	ADJUSTMENT	REMARKS
17	Overall Frequency Response at Tape Speed 1-7/8 ips	400 Hz (0 dB) and 10 Hz to 22 kHz (-20 dB) to INPUT Jacks	VTVM and Distortion Meter to OUTPUT Jacks	Record, Playback Monitor SW - Source/Tape Display SW - VU or P. Hold Tape SW - EX/SX/ZX Eq. SW - 120 μs (EX) 70 μs (SX/ZX) Dolby NR SW - OUT Tape Speed SW - 1-7/8 ips	Main P.C.B. L102, L202	For each tape to be used, perform the Auto Azimuth Alignment operation by depressing Record and Play Buttons simultaneously after setting the Display Switch to CAL. 1. Set the Monitor Switch to Source. 2. Feed in 400 Hz (0 dB) and adjust input level controls to obtain 0 dB on the FL level indicators. 3. Switch the Generator output level to -20 dB. 4. Set the Monitor Switch to Tape, then record and play it back. 5. Feed in 10 Hz to 22 kHz (-20 dB), and check to insure if the output levels are within -20 dB ± 3 dB. 6. If above is not sufficient, adjust L102 (L202) to obtain approx. -20 dB on the VTVM. 7. Conduct step 16 "Record Level Calibration and Recording Bias Current Adjustment". 8. If above is not sufficient, precise re-adjustment of step 8 "Playback Frequency Response", replacement of Playback Head or Record Head, or check on item 4.10 "Tape Travelling Adjustment" will be required.
18	Overall Frequency Response at Tape Speed 15/16 ips	400 Hz (0 dB) and 10 Hz to 15 kHz (-20 dB) to INPUT Jacks	Same as above	Record, Playback Monitor SW - Source/Tape Display SW - VU or P. Hold Tape SW - EX/SX/ZX Eq. SW - 120 μs (EX) 70 μs (SX/ZX) Dolby NR SW - OUT Tape Speed SW - 15/16 ips	Main P.C.B. L102, L202	For each tape to be used, perform the Auto Azimuth Alignment operation by depressing Record and Play Buttons simultaneously after setting the Display Switch to CAL. 1. Set the Monitor Switch to Source. 2. Feed in 400 Hz (0 dB) and adjust input level controls to obtain 0 dB on the FL level indicators. 3. Switch the Generator output level to -20 dB. 4. Set the Monitor Switch to Tape, then record and play it back. 5. Feed in 10 Hz to 15 kHz (-20 dB), and check to insure if the output levels are within -20 dB ± 3 dB. 6. If above is not sufficient, adjust L102 (L202) to obtain approx. -20 dB on the VTVM. 7. Conduct step 16 "Record Level Calibration and Recording Bias Current Adjustment". 8. If above is not sufficient, precise re-adjustment of step 8 "Playback Frequency Response", replacement of Playback Head or Record Head, or check on item 4.10 "Tape Travelling Adjustment" will be required.

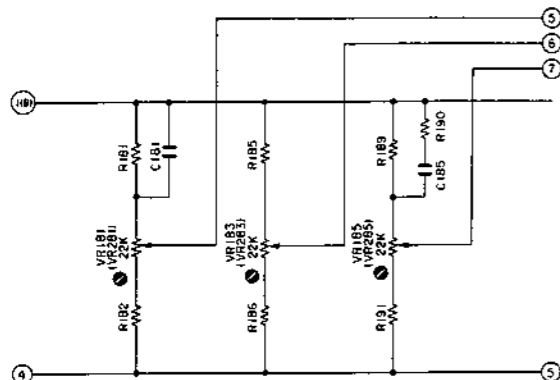

Fig. 6.14 15. Record Head Azimuth Phase
16. Record Level and Bias

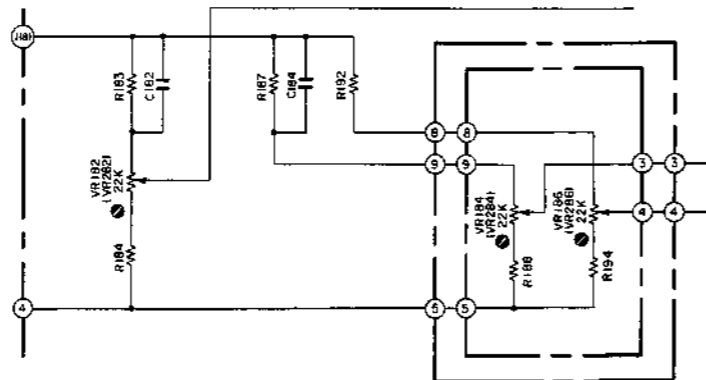
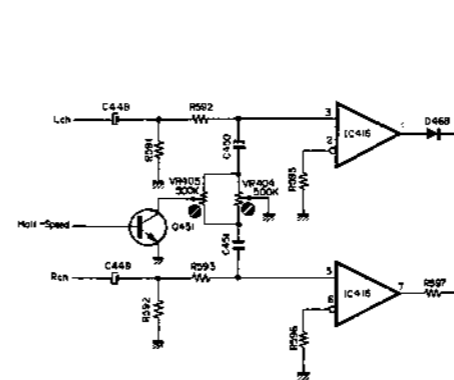

Fig. 6.15 15. Record Head Azimuth Phase
16. Record Level and Bias



STEP	ITEM	SIGNAL SOURCE	OUTPUT CONNECTION	MODE	ADJUSTMENT	REMARKS
19	Crosstalk	1 kHz to INPUT Jacks	1 kHz Band Pass Filter, VTVM to OUTPUT Jacks	Record and Playback Monitor SW – Tape Display SW – VU or P. Hold Tape SW – ZX Eq. SW – 70 μs Dolby NR SW – OUT Tape Speed SW – 1-7/8 ips		1. Erase the tape with bulk eraser. 2. Adjust input level controls to obtain 0 dB on the FL level indicators, and record the signals on the reference tape. 3. Turn the cassette tape the other way round and play it back. 4. Measure the difference between 2 and 3.
20	Channel Separation	1 kHz to INPUT Jacks	Same as above	Same as above		1. Erase the tape with bulk eraser. 2. Adjust Lch (Rch) input level control to obtain 0 dB on the FL level indicators, and close Rch (Lch) input level control. 3. Record and play it back, then measure the Rch (Lch) level.
21	Erasure	1 kHz to INPUT Jacks	1 kHz Band Pass Filter, VTVM to OUTPUT Jacks	Same as above		1. Erase the tape with bulk eraser. 2. Adjust input level controls to obtain 0 dB on the FL level indicators, and record the signals on the reference tape. 3. Rewind the tape then close input level controls. 4. Record and play it back, then measure the difference between 2 and 3.
22	Signal to Noise Ratio	400 Hz to INPUT Jacks	VTVM and Distortion Meter to OUTPUT Jacks	Record and Playback Monitor SW – Tape Display SW – VU or P. Hold Tape SW – ZX Eq. SW – 70 μs Dolby NR SW – MPX		1. Feed in 400 Hz and record, and play it back. 2. Adjust the input level controls to obtain 3% total harmonic distortion in playback mode. 3. Close the input level controls then record. 4. After rewound, play back and check the output level difference between 2 and 3. Note: The filter of IHF-A curve shall be used in the measurements.
23	Total Harmonic Distortion	400 Hz to INPUT Jacks	Distortion Meter to OUTPUT Jacks	Record and Playback Monitor SW – Tape Display SW – VU or P. Hold Tape SW – EX/SX/ZX Eq. SW – 120 μs (EX) 70 μs (SX/ZX) Dolby NR SW – OLT Tape Speed SW – 1-7/8 ips/ 15/16 ips		Tape Speed 1-7/8 ips: 1. Adjust input level controls to obtain 0 dB on the FL level indicators. 2. Record and play it back. 3. Read the distortion meter and check to insure that the distortion is less than 0.8% for ZX tape and 1.0% for SX and EXII tapes. Tape Speed 15/16 ips: 1. Adjust input level controls to obtain 0 dB on the FL level indicators. 2. Record and play it back. 3. Read the distortion meter and check to insure that the distortion is less than 1.5% for ZX tape and 2.0% for SX and EXII tapes.
24	Wow/Flutter	3 kHz Speed and Wow/Flutter Tapes (DA09006A and DA09049A)	Wow/Flutter Meter to OUTPUT Jacks	Playback Monitor SW – Tape Display SW – VU or P. Hold Eq. SW – 70 μs Tape Speed SW – 1-7/8 / 15/16 ips		Play back and read the wow/flutter meter.

6.2. Frequency Response Adjustment at Standard Speed (1-7/8 ips)

(1) Playback Frequency Response Adjustment at Standard Speed (1-7/8 ips)

Refer to Figs. 6.19 – 6.21.

(a) Level Adjustment (for middle frequency response)

This adjustment will be required when playback level is not sufficient at 10 kHz PB Frequency Response Tape (refer to step 8 in "6.1. Adjustment and Measurement Instructions").

Playback equalization level can be varied by the modification of R108 (R208) and R109 (R209).

Following are the details for level modification:

Approx. +1 dB	R109 (R209): 3.0K
	R108 (R208): 4.3K
0 dB	R109 (R209): 3.3K
	R108 (R208): 4.7K
Approx. -1 dB	R109 (R209): 3.6K
	R108 (R208): 5.1K

(b) Peaking Adjustment (for high frequency response)

This adjustment will be required when playback level is not sufficient at 20 kHz PB Frequency Response Tape (refer to step 8 in "6.1. Adjustment and Measurement Instructions").

Peaking portion compensates the gap loss of the playback head.

Peaking level is varied by the short circuit of R112 (R212) as illustrated in Fig. 6.20.

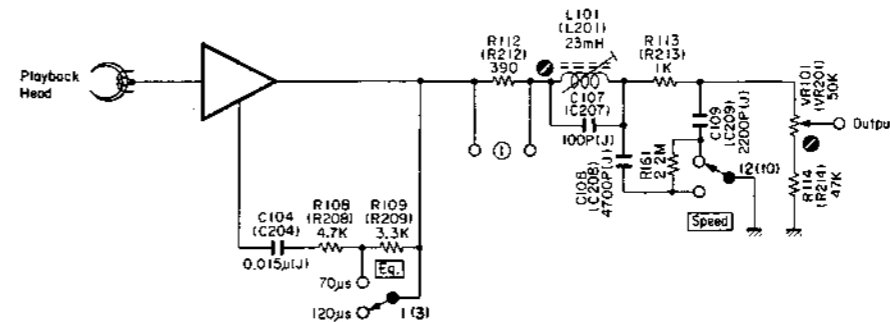

Fig. 6.19 Playback Amp.

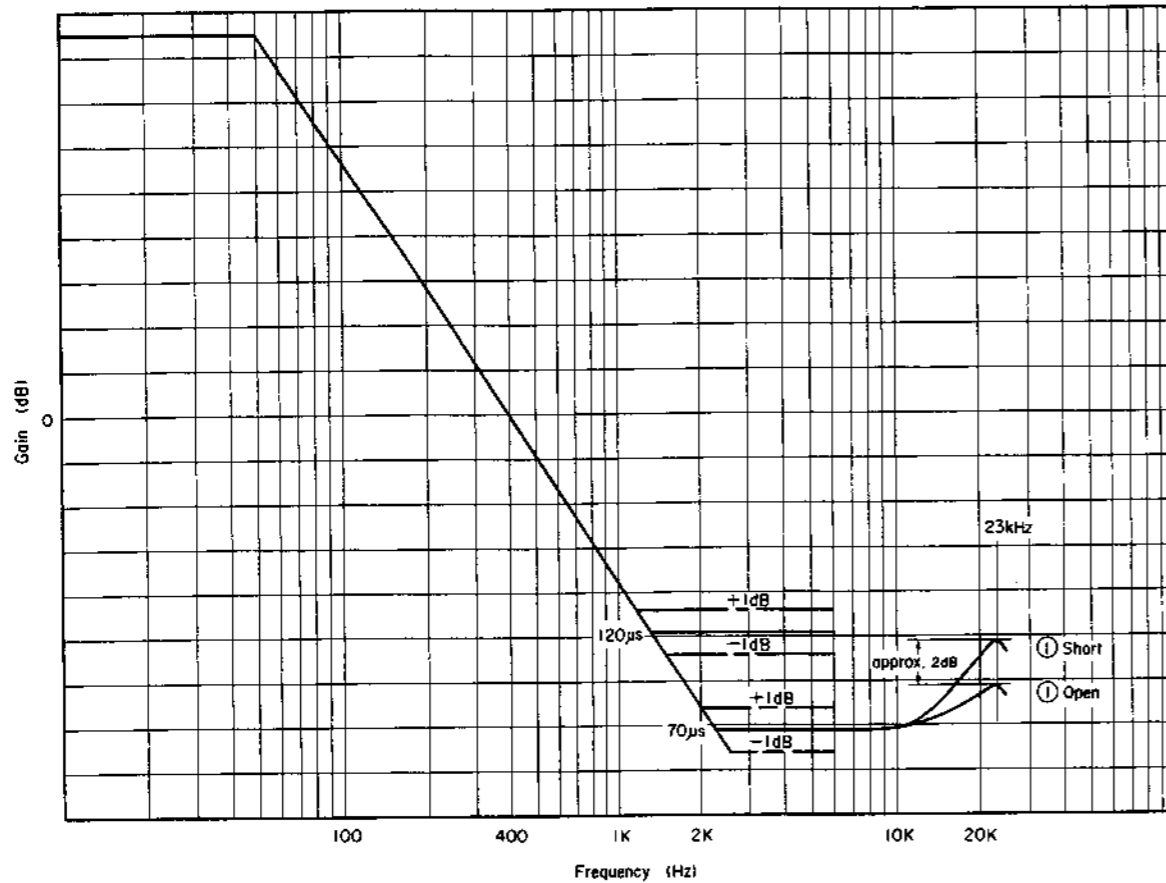

Fig. 6.20 Playback Equalization Curve (1-7/8 ips)

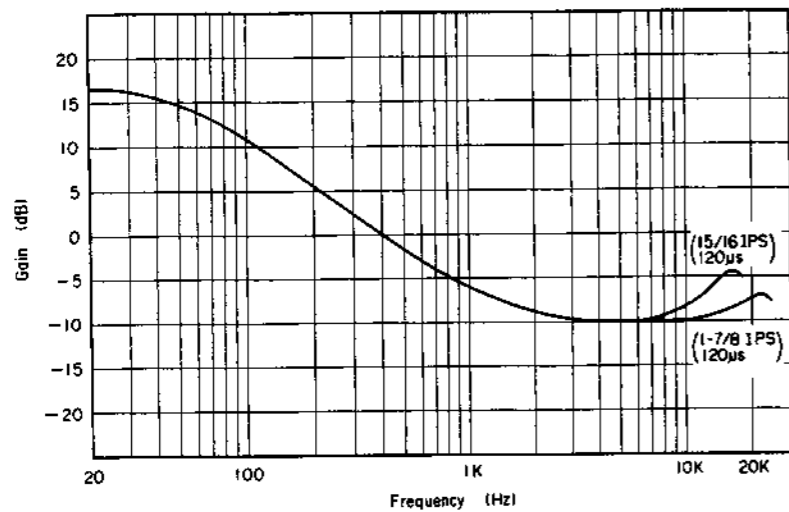

Fig. 6.21 Typical Playback Equalization Curve (1-7/8 / 15/16 ips)

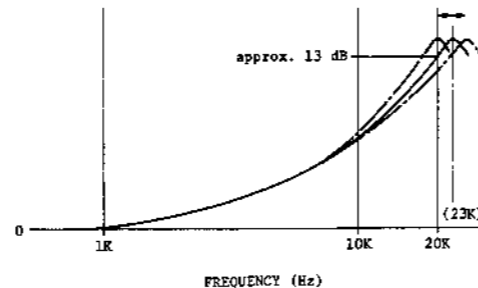

Fig. 6.22 Record Peaking Curve (1-7/8 ips)

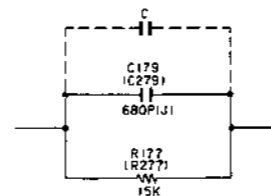

Fig. 6.23

(2) Record Current Frequency Response Adjustment at Standard Speed (1-7/8 ips)

Record eq. peaking is adjusted for compensating the overall frequency response when playback frequency response is completed.

Normally however, peaking frequency is pre-adjusted to approx. 23 kHz in record mode. See Fig. 6.22.

(a) For ZX Tape

1) Feed in 400 Hz (0 dB), then record and play it back. Adjust bias current by VR167 (VR267) on the Switch P.C.B. to obtain a 0.8% distortion.

2) Feed in 10 kHz and 400 Hz (-20 dB) then record and play it back.

Check the difference of the levels between 10 kHz and 400 Hz, and mount an additional capacitor in parallel with the C179 (C279) on the Switch P.C.B. from the dip side of the printed circuit board depending upon the difference of the levels against 400 Hz. See Fig. 6.23.

	Add	Total
0 dB	0	680 pF
-1 dB	330 pF	1010 pF
-2 dB	680 pF	1360 pF

3) Feed in 22 kHz (-20 dB) then record and play it back.

Adjust record peaking coil L102 (L202) to obtain flat overall frequency response.

(b) For SX Tape

1) Feed in 15 kHz and 400 Hz (-20 dB), then record and play it back.

Adjust bias current by VR166 (VR266) on the Switch P.C.B. to obtain flat overall frequency response.

2) Feed in 22 kHz and 400 Hz (-20 dB), then record and play it back.

And check to insure that the overall frequency response is flat.

(c) For EX Tape

1) Feed in 15 kHz and 400 Hz (-20 dB), then record and play it back.

Adjust bias current by VR165 (VR265) on the Switch P.C.B. to obtain flat overall frequency response.

2) Feed in 22 kHz and 400 Hz (-20 dB), then record and play it back.

And check to insure that the overall frequency response is flat.

6.3. Dolby NR Circuit Check

Dolby NR circuit incorporates a Dolby B-Type NR IC (μ A7300PC) which has no adjustment point.

Perform the following checks and make sure that the IC operates accurately i.e. accuracy of frequency response through IC.

(1) Playback Dolby NR Circuit (IC101 (IC201) on the Main P.C.B.)

Signal Source: 5 kHz to No. 9 pin of IC101 and IC201

Output Connection: VTVM to the test points TP101 and TP201 on the Main P.C.B.

Mode: Stop
Monitor SW - Tape
Dolby NR SW - OUT/IN

(a) Connect a VTVM to TP101 (TP201) on the Main P.C.B.

Feed in 5 kHz to No. 9 of IC101 (IC201) and adjust the generator output control so that the VTVM may read 7.6 mV at each test point.

(b) Set the Dolby NR Switch to IN. Check to insure that the level at TP101 (TP201) is 3 mV \pm 1.5 dB.

(2) Record Dolby NR Circuit (IC161 (IC261) on the Switch P.C.B.)

Signal Source: 5 kHz to INPUT Jacks

Output Connection: VTVM to the output side of C178 (C278) on the Switch P.C.B.

Mode: Stop
Monitor SW - Source

(a) Connect a VTVM to TP101 (TP201) on the Main P.C.B.

Feed in 5 kHz and adjust the input level so that the VTVM may read 100 mV (0 dB) at each test point. FL level indicators will indicate 0 dB.

(b) Remove the VTVM from TP101 (TP201) and reconnect it to the output side of C178 (C278). Check to insure that the VTVM indicates approx. 560 mV.

(c) Decrease the input level (0 dB) by 20 dB or 30 dB. Check to insure that the level at output side of C178 (C278) corresponds to the following with Dolby NR Switch IN and OUT.

Input Level:	Capacitor Output Level		
	Dolby NR OUT	Dolby NR IN	Difference between IN and OUT
(f=5 kHz)			
-20 dB	-20 dB	-16.8 dB \pm 1.5 dB	3.2 dB \pm 1.5 dB
-30 dB	-30 dB	-21.8 dB \pm 1.5 dB	8.2 dB \pm 1.5 dB

7. MOUNTING DIAGRAMS

Note: Mounting diagram shows a dip side view of the printed circuit board.

7.1. Main P.C.B. Ass'y

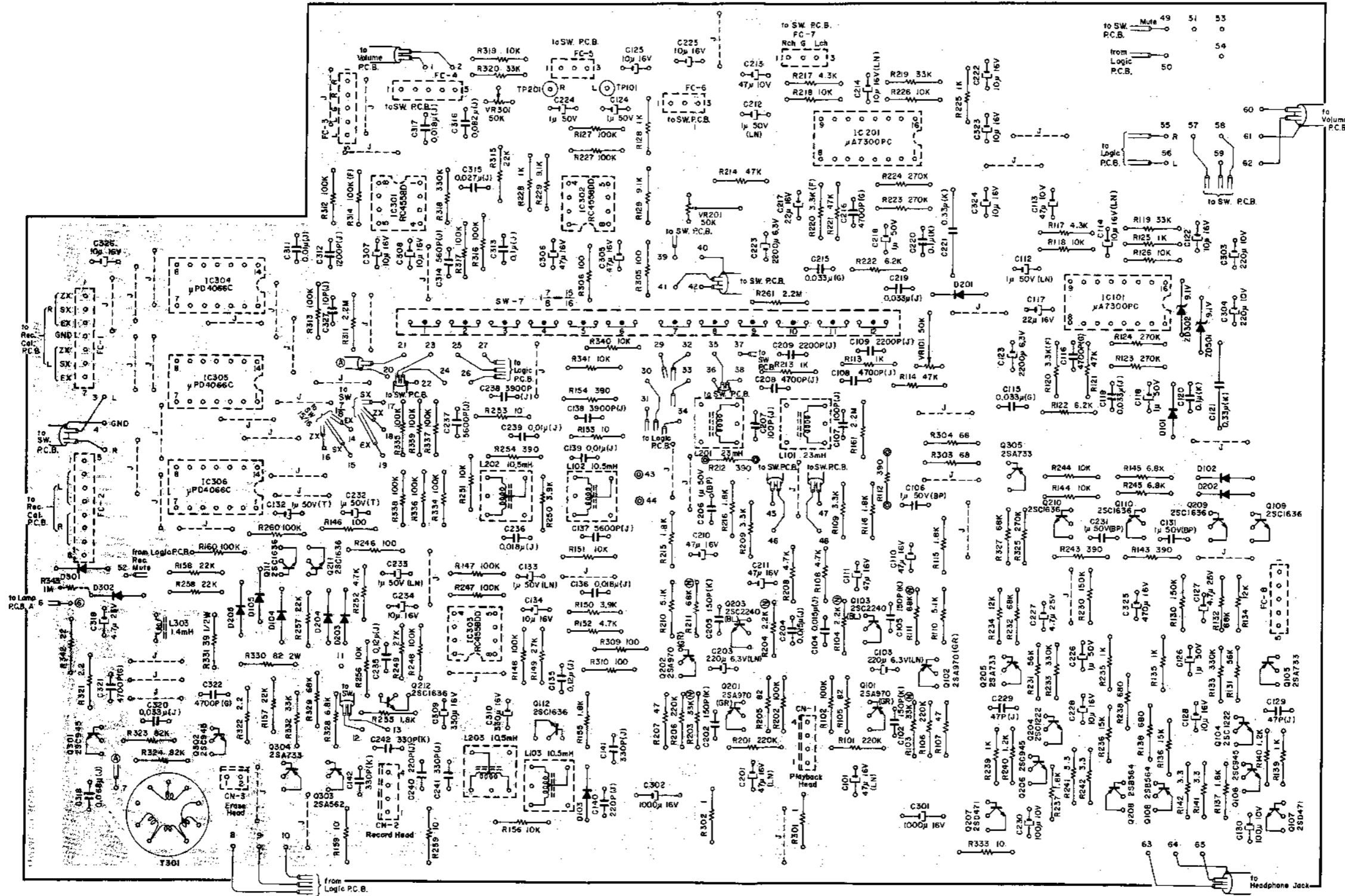

Fig. 7.1

Note: Diode is 1SS53 unless otherwise specified.

Schematic Ref. No.	Part No.	Description	Schematic Ref. No.	Part No.	Description	Schematic Ref. No.	Part No.	Description	Schematic Ref. No.	Part No.	Description
	BA04058C	Main P.C.B. Ass'y									
	- PB Eq. Amp. -										
Q101, 102 201, 202	OB06180A	Transistor 2SA970 (GR)	C117, 217 C118, 218 C119, 219 C120, 220 C121, 221 C122, 222 323, 324	OB01862A Electrolytic Capacitor 22μ 16V OB01405A Electrolytic Capacitor 1μ 50V OB05583A Mylar Capacitor 0.033μ 50V J OB01603A Mylar Capacitor 0.1μ 50V K OB01602A Mylar Capacitor 0.33μ 50V K OB01412A Electrolytic Capacitor 10μ 16V	R145, 245 R301, 302 R305, 306 R325 R327 C124, 224 C125, 225 C131, 231 C301, 302 C305, 306	OB01682A Carbon Resistor 6.8K ERD-25T J OB09214A Fail Safe Type Resistor 1 RDF-25S J OB09215A Fail Safe Type Resistor 100 RDF-25S J OB05620A Carbon Resistor 270K ERD-25T J OB05692A Carbon Resistor 68K ERD-25T J OB01405A Electrolytic Capacitor 1μ 50V OB01412A Electrolytic Capacitor 10μ 16V OB09187A Electrolytic Capacitor 1μ 50V (BP) OB01397A Electrolytic Capacitor 1000μ 16V OB01403A Electrolytic Capacitor 47μ 16V	R312, 313 316, 317 R314 R315 R318 R319 R320 C307, 308 C311 C312 C313 C314 C315 C316 C317 C327	OB01889A Carbon Resistor 100K ERD-25T J OB09305A Metal Film Resistor 100K SN14K2E F OB05615A Carbon Resistor 22K ERD-25T J OB05627A Carbon Resistor 330K ERD-25T J OB01888A Carbon Resistor 10K ERD-25T J OB05509A Carbon Resistor 33K ERD-25T J OB01412A Electrolytic Capacitor 10μ 16V OB05681A Mylar Capacitor 0.01μ 50V J OB05687A Mylar Capacitor 1200P 50V J OB01780A Mylar Capacitor 0.1μ 50V J OB09323A PP Capacitor 560P 100V J OB09045A Mylar Capacitor 0.027μ 50V J OB05685A Mylar Capacitor 0.082μ 50V J OB05832A Mylar Capacitor 0.018μ 50V J OB09277A Ceramic Capacitor 10P 50V J			
Q103, 203 L101, 201 VR101, 201 R101, 106 201, 206 R102, 202 R103, 203	OB06142A OB03563A OB07228A OB05625A	Transistor 2SC2240 (BL) 19K Coil 23mH Semi-fixed Volume 50K Carbon Resistor 220K ERD-25T J	C123, 223 C303, 304	OB09257A Electrolytic Capacitor 2200μ 6.3V OB05899A Electrolytic Capacitor 220μ 10V OB06201A IC Socket 16P (2 pcs.)							
R104, 204	OB01889A OB09310A OB09309A	Carbon Resistor 100K ERD-25T J Carbon Resistor 33K ERD-25T J (Noiseless) Carbon Resistor 2.2K ERD-25T J (Noiseless)	IC303 Q111, 112 211, 212 Q304	OB06146A IC RC4558DD OB06070A Transistor 2SC1636 OB06013A Transistor 2SA733 OB06181A Silicon Diode 1SS53	Q104, 204 Q105, 205 Q106, 206 Q107, 207 Q108, 208 R130, 230 R131, 231 R132, 232 R133, 233 R134, 234 R135, 139 235, 239 R136, 236 R137, 237 R138, 238 R140, 240 R141, 142 241, 242	OB06062A Transistor 2SC1222 OB06013A Transistor 2SA733 OB01872A Transistor 2SC945 (L) OB06066A Transistor 2SD471 OB06069A Transistor 2S8564 OB05626A Carbon Resistor 150K ERD-25T J OB05508A Carbon Resistor 56K ERD-25T J OB05692A Carbon Resistor 68K ERD-25T J OB05627A Carbon Resistor 330K ERD-25T J OB09263A Carbon Resistor 12K ERD-25T J OB01857A Carbon Resistor 1K ERD-25T J	IC304, 305 306 D301, 302 R334, 335 336, 337 338, 339 R340, 341 R342 R343 C326 SW7 CN1, 2 CN3	OB07826D Main P.C.B. OB06144A IC μPD4066C OB06181A Silicon Diode 1SS53 OB01889A Carbon Resistor 100K ERD-25T J OB01888A Carbon Resistor 10K ERD-25T J OB09049A Fail Safe Type Resistor 22 RDF-25S J OB05776A Carbon Resistor 1M ERD-25T J OB01412A Electrolytic Capacitor 10μ 16V OB07278A Slide Switch OB08654A 4P-T Post OB08656A 2P-T Post			
R105, 205 R107, 207 R108, 208 R109, 209 R110, 210 R111, 211	OB05631A OB01706A OB01846A OB01681A OB09314A OB09311A	Carbon Resistor 82 ERD-25T J Carbon Resistor 47 ERD-25T J Carbon Resistor 4.7K ERD-25T J Carbon Resistor 3.3K ERD-25T J Carbon Resistor 5.1K ERD-25T J Carbon Resistor 68K ERD-25T J (Noiseless)	R146, 246 R147, 148 160, 247 248, 260 R149, 249 R150, 250 R151, 156 251, 256 R152, 252 R153, 253 R154, 254 R155, 255 R157, 158 257, 258 R309, 310 R329 R332 C132, 232 C133, 233 C134, 234 C135, 235 C136, 236 C137, 237 C138, 238 C139, 239 C140, 240 C141, 241 C309, 310	OB01679A Carbon Resistor 100 ERD-25T J OB01889A Carbon Resistor 100K ERD-25T J OB05743A Carbon Resistor 27K ERD-25T J OB05675A Carbon Resistor 3.9K ERD-25T J OB01888A Carbon Resistor 10K ERD-25T J OB01846A Carbon Resistor 4.7K ERD-25T J OB05936A Carbon Resistor 10 ERD-25T J OB05691A Carbon Resistor 390 ERD-25T J OB05614A Carbon Resistor 1.8K ERD-25T J OB05615A Carbon Resistor 22K ERD-25T J OB09215A Fail Safe Type Resistor 100 RDF-25S J OB05692A Carbon Resistor 68K ERD-25T J OB05509A Carbon Resistor 33K ERD-25T J OB09094A Tantalum Capacitor 1μ 50V OB09223A Electrolytic Capacitor 1μ 50V (LN) OB01412A Electrolytic Capacitor 10μ 16V OB05909A Mylar Capacitor 0.12μ 50V J OB05832A Mylar Capacitor 0.018μ 50V J OB05659A Mylar Capacitor 5600P 50V J OB01804A Mylar Capacitor 3900P 50V J OB05681A Mylar Capacitor 0.01μ 50V J OB09247A Mica Capacitor 220P 50V J OB09322A PP Capacitor 330P 100V J OB01502A Electrolytic Capacitor 330μ 16V	R112, 212 R113, 213 R114, 214 R115, 116 215, 216 R161, 261 C101, 201 C102, 105 202, 205 C103, 203 C104, 204 C106, 206 C107, 207 C108, 208 C109, 209 C110, 111 210, 211	OB05691A Carbon Resistor 390 ERD-25T J OB01857A Carbon Resistor 1K ERD-25T J OB05641A Carbon Resistor 47K ERD-25T J OB05614A Carbon Resistor 1.8K ERD-25T J OB05671A Carbon Resistor 2.2M ERD-25T J OB09218A Electrolytic Capacitor 47μ 16V (LN) OB09281A Ceramic Capacitor 150P 50V K OB09151A Electrolytic Capacitor 220μ 6.3V (LN) OB05557A Mylar Capacitor 0.015μ 50V J OB09187A Electrolytic Capacitor 1μ 50V (BP) OB09302A Mica Capacitor 100P 50V J OB05652A Mylar Capacitor 4700P 50V J OB01802A Mylar Capacitor 2200P 50V J OB01403A Electrolytic Capacitor 47μ 16V					
	- PB Dolby NR -										
IC101, 201 ZD301, 302 D101, 201 R117, 217 R118, 126 218, 226 R119, 219 R120, 220 R121, 221 R122, 222 R123, 124 223, 224 R125, 225 R303, 304 C112, 212 C113, 213 C114, 214 C115, 215 C116, 216	OB06200A OB06232A OB06181A OB09307A OB01888A OB05509A OB09317A OB05641A OB09271A OB05620A OB01857A OB09306A OB09223A OB01836A OB09386A OB09240A OB09191A	IC μA7300PC Zener Diode 9.1V Silicon Diode 1SS53 Carbon Resistor 4.3K ERD-25T J Carbon Resistor 10K ERD-25T J Carbon Resistor 33K ERD-25T J Metal Film Resistor 3.3K SN14K2E F Carbon Resistor 47K ERD-25T J Carbon Resistor 6.2K ERD-25T J Carbon Resistor 270K ERD-25T J Carbon Resistor 1K ERD-25T J Fail Safe Type Resistor 68 RDF-25S J Electrolytic Capacitor 1μ 50V (LN) Electrolytic Capacitor 47μ 10V Electrolytic Capacitor 10μ 16V (LN) PP Capacitor 0.033μ 100V G PP Capacitor 4700P 100V G	IC302 Q109, 110 209, 210 Q305 D102, 202 R127, 227 R128, 228 R129, 229 R143, 243 R144, 244	OB06146A IC RC4558DD OB06070A Transistor 2SC1636 OB06013A Transistor 2SA733 OB06181A Silicon Diode 1SS53 OB01889A Carbon Resistor 100K ERD-25T J OB01857A Carbon Resistor 1K ERD-25T J OB05694A Carbon Resistor 9.1K ERD-25T J OB05691A Carbon Resistor 390 ERD-25T J OB01888A Carbon Resistor 10K ERD-25T J	Q301, 302 Q303 T301 L303 R159, 259 R321, 322 R323, 324 R328 R330 R331 C142, 242 C318 C319 C320 C321, 322	OB01872A Transistor 2SC945 (L) OB01426A Transistor 2SA562 OB06613A Osc. Coil OB03861B Inductor 1.4mH OB05936A Carbon Resistor 10 ERD-25T J OB09212A Fail Safe Type Resistor 2.2 RDF-25S J OB05668A Carbon Resistor 82K ERD-25T J OB01682A Carbon Resistor 6.8K ERD-25T J OB09295A Fail Safe Type Resistor 82 RDF-2B J OB09296A Fail Safe Type Resistor 39 RDF-1/2S J OB09285A Ceramic Capacitor 330P 50V K OB09254A PP Capacitor 0.068μ 100V J OB01402A Electrolytic Capacitor 4.7μ 25V OB05583A Mylar Capacitor 0.033μ 50V J OB09191A PP Capacitor 4700P 100V G					
	- Rec. Amp. -										
	- Headphone Amp. -										
	- Bias Osc. -										
	- Tone Osc. -										

7.2. Switch P.C.B. Ass'y

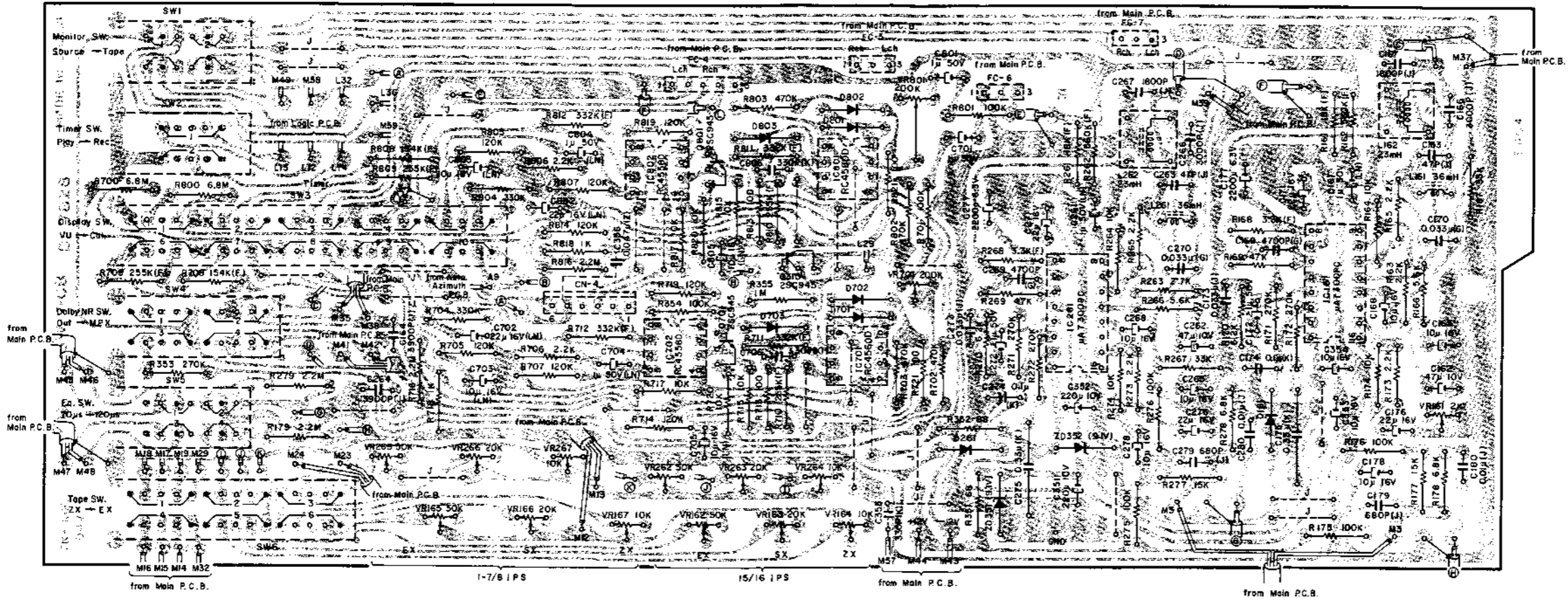

Fig. 7.2

Note: Diode is 1SS53 unless otherwise specified.

7.3. Record Cal. P.C.B. A Ass'y

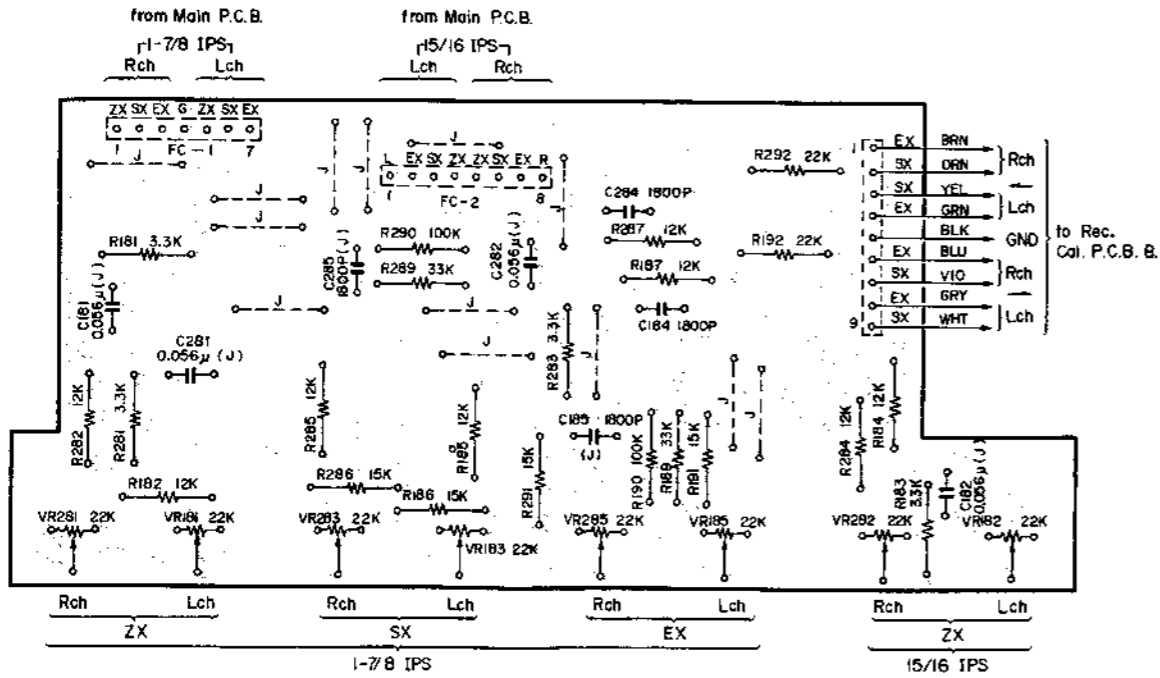

Fig. 7.3

7.4. Record Cal. P.C.B. B Ass'y

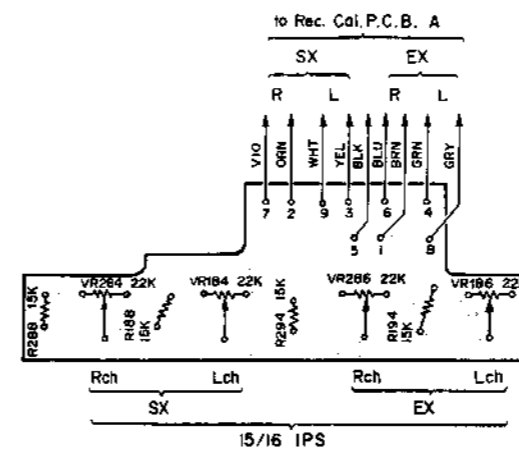

Fig. 7.4

Schematic Ref. No.	Part No.	Description	Schematic Ref. No.	Part No.	Description	Schematic Ref. No.	Part No.	Description
	BA04059B	Switch P.C.B. Ass'y	R163, 165 173, 265 273	OB05622A	Carbon Resistor 2.2K ERD-25T J		BA04067A	Rec. Cal. P.C.B. A Ass'y
	- Detector -		R164, 174 264, 274	OB01888A	Carbon Resistor 10K ERD-25T J	VR181, 182 183, 185 281, 282 283, 285	OB07833A OB07276A	Rec. Cal. P.C.B. A Semi-fixed Volume 22K
IC701, 801	OB06217A	IC RC4560D	R166, 266	OB01887A	Carbon Resistor 5.6K ERD-25T J	R181, 183 281, 283	OB01681A	Carbon Resistor 3.3K ERD-25T J
IC702, 802	OB06124B	IC RC4558D	R167, 267	OB05509A	Carbon Resistor 33K ERD-25T J	R182, 184 185, 187 282, 284 285, 287	OB09263A	Carbon Resistor 12K ERD-25T J
Q310, 701 801	OB06100A	Transistor 2SC945 (A)	R168, 268	OB09317A	Metal Film Resistor 3.3K SN14K2E F	R186, 191 286, 291	OB01683A	Carbon Resistor 15K ERD-25T J
D701, 702 703, 801 802, 803	OB06181A	Silicon Diode 1SS53	R169, 269	OB05641A	Carbon Resistor 47K ERD-25T J	R189, 289 R190, 290	OB05509A	Carbon Resistor 33K ERD-25T J
VR701	OB07161A	Semi-fixed Volume 200K	R170, 270	OB09271A	Carbon Resistor 6.2K ERD-25T J	R192, 292 C181, 182 281, 282 C184, 185 284, 285	OB01889A	Carbon Resistor 100K ERD-25T J
VR801	OB07154A	Semi-fixed Volume 200K	R171, 172 271, 272 353	OB05620A	Carbon Resistor 270K ERD-25T J	FC1	OB05615A	Carbon Resistor 22K ERD-25T J
R354, 701 801	OB01889A	Carbon Resistor 100K ERD-25T J	R175, 176 275, 276	OB01889A	Carbon Resistor 100K ERD-25T J	FC2	OB05813A	Mylar Capacitor 0.056μ 50V J
R355	OB05776A	Carbon Resistor 1M ERD-25T J	R177, 277	OB01683A	Carbon Resistor 15K ERD-25T J		OB01913A	Mylar Capacitor 1800P 50V J
R700, 800	OB09347A	Carbon Resistor 6.8M ERD-25T J	R178, 278	OB01682A	Carbon Resistor 6.8K ERD-25T J		OB05235A	7P Flat Cable 90mm
R702, 703 802, 803	OB01684A	Carbon Resistor 470K ERD-25T J	R179, 279 R263	OB05671A	Carbon Resistor 2.2M ERD-25T J		OB05236A	8P Flat Cable 90mm
R704, 804	OB05627A	Carbon Resistor 330K ERD-25T J	R351, 352	OB05629A	Carbon Resistor 2.7K ERD-25T J			
R705, 707 714, 719 805, 807 814, 819	OB05621A	Carbon Resistor 120K ERD-25T J	C161, 261	OB09306A	Fail Safe Type Resistor 68 RDF-25S J			
R706, 806	OB05622A	Carbon Resistor 2.2K ERD-25T J	C162, 262	OB09223A	Electrolytic Capacitor 1μ 50V (LN)			
R708, 808	OB09348A	Metal Film Resistor 154K SN14K2E F	C162, 262	OB01836A	Electrolytic Capacitor 47μ 10V			
R709, 710 809, 810	OB09316A	Metal Film Resistor 255K SN14K2E F	C163, 263	OB09242A	Mica Capacitor 47P 50V J			
R711, 712 811, 812	OB09315A	Metal Film Resistor 332K SN14K2E F	C164, 264	OB01804A	Mylar Capacitor 3900P 50V J			
R713, 721 813, 821	OB01679A	Carbon Resistor 100 ERD-25T J	C165, 178 265, 278 353, 354	OB01412A	Electrolytic Capacitor 10μ 16V			
R715, 717 720, 815 817, 820	OB01888A	Carbon Resistor 10K ERD-25T J	C166, 266	OB09262A	PP Capacitor 3000P 100V J			
R716, 816	OB05671A	Carbon Resistor 2.2M ERD-25T J	C167, 267	OB01913A	Mylar Capacitor 1800P 50V J	VR184, 186 284, 286	OB07834A	Rec. Cal. P.C.B. B
R718, 818	OB01857A	Carbon Resistor 1K ERD-25T J	C168, 268	OB09386A	Electrolytic Capacitor 10μ 16V (LN)	R188, 194 188, 294	OB07277A	Semi-fixed Volume 22K
C701, 801	OB01405A	Electrolytic Capacitor 1μ 50V	C169, 269	OB09191A	PP Capacitor 4700P 100V G		OB05591A	Carbon Resistor 15K ERD-25T J
C702, 802	OB09137A	Electrolytic Capacitor 22μ 16V (LN)	C170, 270	OB09240A	PP Capacitor 0.033μ 100V G			
C703, 705 803, 805	OB09148A	Electrolytic Capacitor 10μ 16V (LN)	C171, 176 271, 276	OB01862A	Electrolytic Capacitor 22μ 16V			
C704, 804	OB09223A	Electrolytic Capacitor 1μ 50V (LN)	C172, 272	OB01405A	Electrolytic Capacitor 1μ 50V			
C706, 806 CN4	OB09285A	Ceramic Capacitor 330P 50V K	C173, 273	OB05683A	Mylar Capacitor 0.033μ 50V J			
	OB08642A	6P-T Post	C174, 274	OB01603A	Mylar Capacitor 0.1μ 50V K			
	- Rec. Dolby NR -		C175, 275	OB01602A	Mylar Capacitor 0.33μ 50V K			
IC161, 261	OB06200A	IC μA7300PC	C177, 277	OB09257A	Electrolytic Capacitor 2200μ 6.3V			
ZD351, 352	OB06232A	Zener Diode 9.1V	C179, 279	OB09235A	PP Capacitor 680P 100V J			
D161, 261	OB06181A	Silicon Diode 1SS53	C180, 280	OB05681A	Mylar Capacitor 0.01μ 50V J			
L161, 261	OB03919B	Inductor 36mH	C351, 352	OB05899A	Electrolytic Capacitor 220μ 10V			
L162, 262	OB03563A	19K Coil 23mH	C355	OB09285A	Ceramic Capacitor 330P 50V K			
VR161	OB09062A	Semi-fixed Volume 2K	C356	OB09387A	Ceramic Capacitor 0.047μ 50V Z			
VR162, 165 262, 265	OB07058A	Semi-fixed Volume 50K	SW1	OB07286A	Lever Switch 4-2 O			
VR163, 166 263, 266	OB07215A	Semi-fixed Volume 20K	SW2	OB07284A	Lever Switch 2-3 S			
VR164, 167 264, 267	OB07162A	Semi-fixed Volume 10K	SW3	OB07288A	Lever Switch 10-3 S			
R161, 261	OB09205A	Metal Film Resistor 18K SN14K2E F	SW4	OB07287A	Lever Switch 4-3 S			
R162, 262	OB09318A	Metal Film Resistor 560K SN14K2E F	SW5	OB07285A	Lever Switch 4-2 S			
			SW6	OB07304A	Lever Switch 6-3 S			
			FC4	OB05238A	5P Flat Cable 50mm			
			FC5, 6, 7	OB05240A	3P Flat Cable 50mm			
				OB06201A	IC Socket 16P (2 pcs.)			
				- Miscellaneous -				
				OB07828D	Switch P.C.B.			

7.5. Logic P.C.B. Ass'y

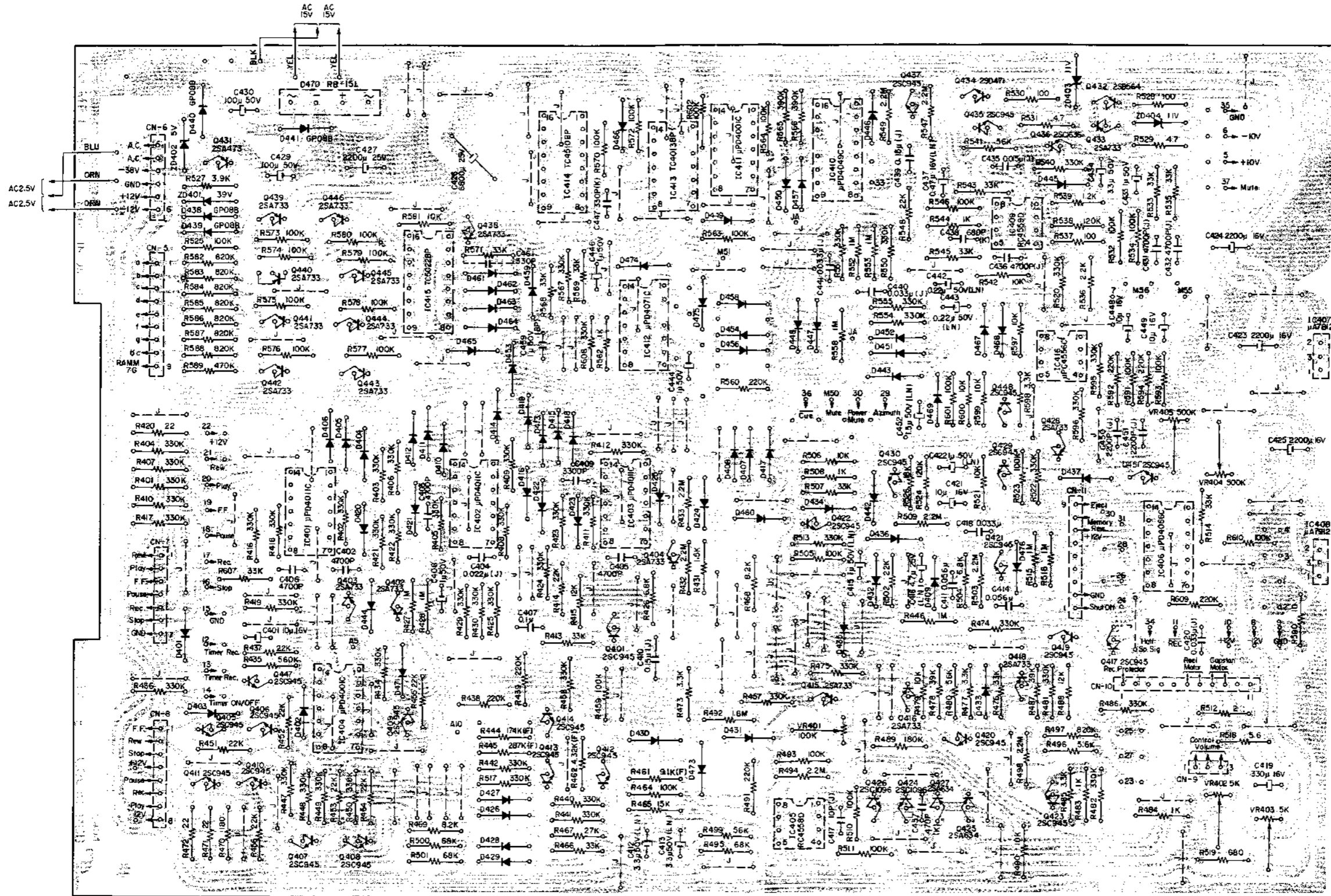

Fig. 7.5

Note: Diode is 1SS53 unless otherwise specified.

Schematic Ref. No.	Part No.	Description	Schematic Ref. No.	Part No.	Description	Schematic Ref. No.	Part No.	Description	Schematic Ref. No.	Part No.	Description
	BA04210A	Logic P.C.B. Ass'y	R413, 466	OB05509A	Carbon Resistor 33K ERD-25T J	C404	OB05582A	Mylar Capacitor 0.022μ 50V J	R544, 562	OB01857A	Carbon Resistor 1K ERD-25T J
	- Logic -		476, 507			C407	OB00093A	Mylar Capacitor 0.1μ 50V	R547, 549	OB05671A	Carbon Resistor 2.2M ERD-25T J
			514, 607			C408	OB01405A	Electrolytic Capacitor 1μ 50V	R548	OB05615A	Carbon Resistor 22K ERD-25T J
			R414, 437	OB05615A	Carbon Resistor 22K ERD-25T J (9 pcs.)	C409	OB09166A	Mylar Capacitor 3300P 50V	R552, 553	OB05776A	Carbon Resistor 1M ERD-25T J
			451-456			C410	OB00610A	Mylar Capacitor 0.15μ 50V	558		
IC401, 402	OB06178A	IC μPD4011C	502			C411, 414	OB01676A	Mylar Capacitor 0.056μ 50V	R560	OB05625A	Carbon Resistor 220K ERD-25T J
403			R415, 488	OB09263A	Carbon Resistor 12K ERD-25T J	C412, 413	OB09324A	Electrolytic Capacitor 3.3μ 16V (LN)	R565, 566	OB05676A	Carbon Resistor 390K ERD-25T J
IC404	OB06143A	IC μPD4001C	R420, 471	OB09049A	Fail Safe Type Resistor				R582-588	OB09320A	Carbon Resistor 820K ERD-25T J (7 pcs.)
IC405	OB06124B	IC RC4558D	472			C415, 422	OB09223A	Electrolytic Capacitor 1μ 50V (LN)	R589	OB01684A	Carbon Resistor 470K ERD-25T J
IC406	OB06144A	IC μPD4066C	R426, 504	OB01682A	Carbon Resistor 6.8K ERD-25T J	C416	OB09173A	Electrolytic Capacitor 4.7μ 16V (LN)	C429, 430	OB09313A	Electrolytic Capacitor 100μ 50V
IC407	OB06192A	Regulator +12V μA7812	R427, 428	OB05776A	Carbon Resistor 1M ERD-25T J	C417	OB09277A	Ceramic Capacitor 10P 50V J	C431, 432	OB05652A	Mylar Capacitor 4700P 50V J
IC408	OB06193A	Regulator -12V μA7912	446, 515			C418, 420	OB05513A	Mylar Capacitor 0.033μ 50V	436		
Q401, 405	OB06100A	Transistor 2SC945 (A)	516			C419	OB01502A	Electrolytic Capacitor 330μ 16V	C434, 444	OB01405A	Electrolytic Capacitor 1μ 50V
406, 407			R431	OB05698A	Carbon Resistor 1.5K ERD-25T J	C423, 424	OB01406A	Electrolytic Capacitor 2200μ 16V	446		
408, 409			R432, 433	OB05671A	Carbon Resistor 2.2M ERD-25T J	425			C434	OB01863A	Electrolytic Capacitor 3.3μ 50V
410, 411			494, 498			C426	OB09374A	Electrolytic Capacitor .6800μ 25V	C434	OB01863A	Electrolytic Capacitor 3.3μ 50V
412, 413			503, 509			C427	OB05654A	Electrolytic Capacitor 2200μ 25V	C435	OB05557A	Mylar Capacitor 0.015μ 50V J
414, 417			R435	OB05784A	Carbon Resistor 560K ERD-25T J	C457	OB09286A	Ceramic Capacitor 470P 50V K	C437	OB09222A	Electrolytic Capacitor 0.47μ 16V (LN)
419, 420			R438, 439	OB05625A	Carbon Resistor 220K ERD-25T J	CN5, 11	OB08645A	9P-T Post	C438	OB09287A	Ceramic Capacitor 680P 50V K
421, 422			491			CN6	OB08642A	6P-T Post	C439	OB00610A	Mylar Capacitor 0.15μ 50V J
423, 429			R444	OB09367A	Metal Film Resistor	CN7	OB08643A	7P-T Post	C440, 441	OB05583A	Mylar Capacitor 0.033μ 50V J
430, 435						CN8	OB08644A	8P-T Post	C442, 443	OB09220A	Electrolytic Capacitor 0.22μ 50V (LN)
447			R445	OB09366A	Metal Film Resistor 287K SN14K2EF	CN9	OB08653A	3P-T Post			
Q402, 403	OB06013A	Transistor 2SA733	R445	OB09366A	Metal Film Resistor 287K SN14K2EF	CN10	OB08655A	11P-T Post	C447	OB09285A	Ceramic Capacitor 330P 50V K
404, 415			R459, 464	OB01889A	Carbon Resistor 100K ERD-25T J				C459	OB09187A	Electrolytic Capacitor 1μ 50V (BP)
416, 418			493, 505						C461	OB01180A	Ceramic Capacitor 330P 100V
428, 433			510, 511								
Q424, 426	OB06020A	Transistor 2SC1096	523, 525								
Q425, 427	OB06012A	Transistor 2SA634	R461	OB09328A	Metal Film Resistor 9.1K SN14K2E F	IC409	OB06127A	IC RC4559D			
Q432	OB06069A	Transistor 2SB564	R463	OB09365A	Metal Film Resistor 4.32K SN14K2E F	IC410	OB06215A	IC TC4049BP			
Q434	OB06066A	Transistor 2SD471	R465	OB09340A	Metal Film Resistor 15K SN14K2E F	IC411	OB06143A	IC μPD4001C			
ZD403, 404	OB06231A	Zener Diode 11V	R467	OB05743A	Carbon Resistor 27K ERD-25T J	IC412	OB06214A	IC TC4071BP			
D401-437	OB01909A	Silicon Diode 1S1555 (43 pcs.)	R468, 469	OB01856A	Carbon Resistor 8.2K ERD-25T J	IC413	OB06213A	IC TC4013BP	IC416	OB06216A	IC μPC4556C
442-444			R470	OB05578A	Carbon Resistor 180 ERD-25T J	IC414	OB06212A	IC TC4510BP	Q448, 451	OB06100A	Transistor 2SC945 (L)
471, 473			R473, 477	OB01681A	Carbon Resistor 3.3K ERD-25T J	IC415	OB06211A	IC TC5022BP	D468, 469	OB06181A	Silicon Diode 1SS53
476			485			Q431	OB06060A	Transistor 2SA473	VR404, 405	OB09107A	Semi-fixed Volume 500K
D438, 439	OB06109A	Silicon Diode GP08B	R478, 487	OB01854A	Carbon Resistor 39K ERD-25T J	Q436	OB06070A	Transistor 2SC1636	R591, 593	OB01889A	Carbon Resistor 100K ERD-25T J
D470	OB06183A	Diode Bridge RB151	R479, 490	OB01888A	Carbon Resistor 10K ERD-25T J	Q437	OB06100A	Transistor 2SC945 (L)	601		
VR401	OB03832A	Semi-fixed Volume 100K	506, 521			Q438-446	OB06013A	Transistor 2SA733 (9 pcs.)	R592, 594	OB05625A	Carbon Resistor 220K ERD-25T J
VR402, 403	OB03831A	Semi-fixed Volume 5K	R480, 499	OB05508A	Carbon Resistor 56K ERD-25T J	ZD401	OB06235A	Zener Diode 39V	609		
R401, 402	OB05627A	Carbon Resistor 330K ERD-25T J	R483, 484	OB01857A	Carbon Resistor 1K ERD-25T J	ZD402	OB06230A	Zener Diode 5V	R595, 596	OB05627A	Carbon Resistor 330K ERD-25T J
403, 404			508			D440, 441	OB06109A	Silicon Diode GP08B	610		
405, 406			R489	OB05640A	Carbon Resistor 180K ERD-25T J	D445-454	OB06181A	Silicon Diode 1SS53 (24 pcs.)	R597, 599	OB01888A	Carbon Resistor 10K ERD-25T J
407, 408			R492	OB05680A	Carbon Resistor 1.8M ERD-25T J	456-467			600		
409, 410			R495, 500	OB05692A	Carbon Resistor 68K ERD-25T J	474, 475			R598	OB01681A	Carbon Resistor 3.3K ERD-25T J
411, 412			501			R527	OB05675A	Carbon Resistor 3.9K ERD-25T J	C448, 449	OB01412A	Electrolytic Capacitor 10μ 16V
416, 417			R496	OB01887A	Carbon Resistor 5.6K ERD-25T J	R532, 534	OB01889A	Carbon Resistor 100K ERD-25T J (16 pcs.)	C450, 451	OB01802A	Mylar Capacitor 2200P 50V J
418, 419			R497	OB09320A	Carbon Resistor 820K ERD-25T J	465, 570			C452	OB09221A	Electrolytic Capacitor 1.5μ 50V (LN)
421, 422			R512	OB09381A	Fail Safe Type Resistor	572-580					
423, 424						602					
425, 429			R518	OB09217A	Fail Safe Type Resistor	R533, 535	OB05509A	Carbon Resistor 33K ERD-25T J			
430, 434						543, 545					
436, 440			R519	OB05794A	Carbon Resistor 680 ERD-25T J	568, 569					
441, 442			R524	OB05621A	Carbon Resistor 120K ERD-25T J	571					
447, 448			R526	OB05560A	Carbon Resistor 18K ERD-25T J	R536	OB05622A	Carbon Resistor 2.2K ERD-25T J			
449, 450			R528, 530	OB09215A	Fail Safe Type Resistor	R537	OB01679A	Carbon Resistor 100 ERD-25T J			
457, 458						R538	OB05621A	Carbon Resistor 120K ERD-25T J			
474, 475			R529, 531	OB09321A	Fail Safe Type Resistor	R539	OB05623A	Carbon Resistor 1.2K ERD-25T J			
481, 482						R540, 550	OB05627A	Carbon Resistor 330K ERD-25T J			
486, 513			R590	OB09216A	Fail Safe Type Resistor	551, 554					
517, 520						555, 567					
522			C401, 421	OB01412A	Electrolytic Capacitor 10μ 16V	608					
			C402, 403	OB05556A	Mylar Capacitor 4700P 50V	R541	OB05508A	Carbon Resistor 56K ERD-25T J			
			405, 406			R542, 581	OB01888A	Carbon Resistor 10K ERD-25T J			

Schematic Ref. No.	Part No.	Description
F1, 2, 3	BA04095A	Fuse P.C.B. Ass'y (U.S.A. & Canada)
	0B07842A	Fuse P.C.B.
	0B08374A	Fuse 1A 250V
	0B08342A	Spark Killer (1 pce.)
	0M04075B	Fuse Caution A112 (1 pce.)
	0M04078B	Fuse Label 1A x 2 (1 pce.)
	0M03782A	Fuse Label 1A (1 pce.)
	0J03834B	Fuse P.C.B. Holder (1 pce.)
0E00606A	Screw M3x6 philips Pan Head (3A) (2 pcs.)	
0E00752A	Eyelet (6 pcs.)	
F1, 2, 3	BA04096A	Fuse P.C.B. Ass'y (Japan)
	0B07842A	Fuse P.C.B.
	0B08686A	Fuse 1A 250V
	0B08363A	Spark Killer (1 pce.)
	0M04078B	Fuse Label 1A x 2 (1 pce.)
	0M03782A	Fuse Label 1A (1 pce.)
	0J03834B	Fuse P.C.B. Holder (1 pce.)
	0E00606A	Screw M3 x 6 Philips Pan Head (3A) (2 pcs.)
0E00752A	Eyelet (6 pcs.)	
F1, 2, 3 F4, 5	BA04097B	Fuse P.C.B. Ass'y (Others)
	0B07842A	Fuse P.C.B.
	0B08263A	Fuse T 315mA 250V
	0B08347A	Fuse T 1A 250V
	0B08349A	Fuse Clip (10 pcs.)
	0B08240A	Spark Killer (1 pce.)
	0M04073A	Fuse Label 315mA (1 pce.)
	0M04131A	Fuse Label 1A x 2 (1 pce.)
	0M04074A	Fuse Label 315mA x 2 (1 pce.)
	0J03834B	Fuse P.C.B. Holder (1 pce.)
	0E00606A	Screw M3 x 6 Philips Pan Head (3A) (2 pcs.)
	0E00752A	Eyelet (6 pcs.)
F1 F2, 3 F4, 5	BA04098B	Fuse P.C.B. Ass'y (UK & Australia)
	0B07842A	Fuse P.C.B.
	0B08665A	Fuse T 160mA 250V
	0B08263A	Fuse T 315mA 250V
	0B08347A	Fuse T 1A 250V
	0B08349A	Fuse Clip (10 pcs.)
	0B08240A	Spark Killer (1 pce.)
	0M04086A	Fuse Label 160mA (1 pce.)
	0M04131A	Fuse Label 1A x 2 (1 pce.)
	0M04074A	Fuse Label 315mA x 2 (1 pce.)
	0J03834B	Fuse P.C.B. Holder (1 pce.)
	0E00606A	Screw M3 x 6 Philips Pan Head (3A) (2 pcs.)
0E00752A	Eyelet (6 pcs.)	
F1 F2, 3 F4, 5	BA04105B	Fuse P.C.B. Ass'y (220V Class 2)
	0B07842A	Fuse P.C.B.
	0B08665A	Fuse T 160mA 250V
	0B08263A	Fuse T 315mA 250V
	0B08347A	Fuse T 1A 250V
	0B08349A	Fuse Clip (10 pcs.)
	0B08445A	Spark Killer (2 pcs.)
	0E00752A	Eyelet (6 pcs.)

7.6. Fuse P.C.B. Ass'y

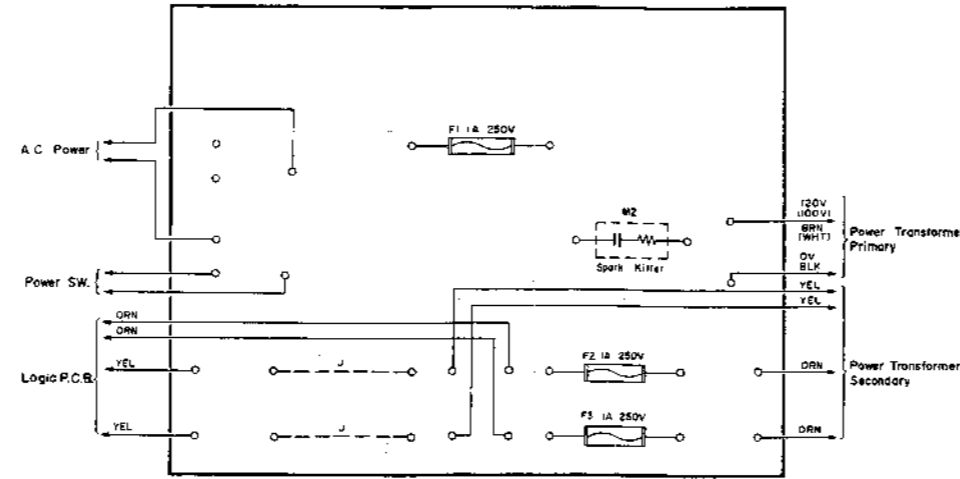

Fig. 7.6.1 U.S.A., Canada & Japan

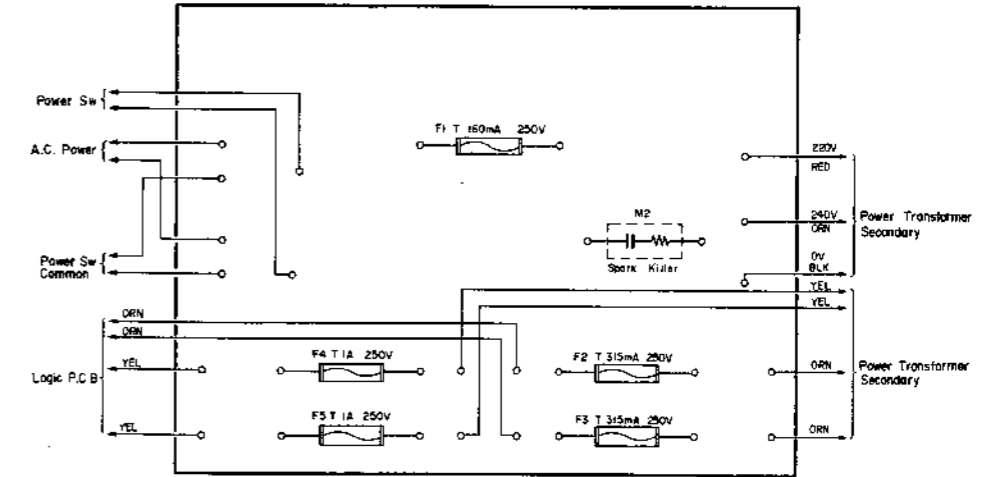

Fig. 7.6.3 UK & Australia

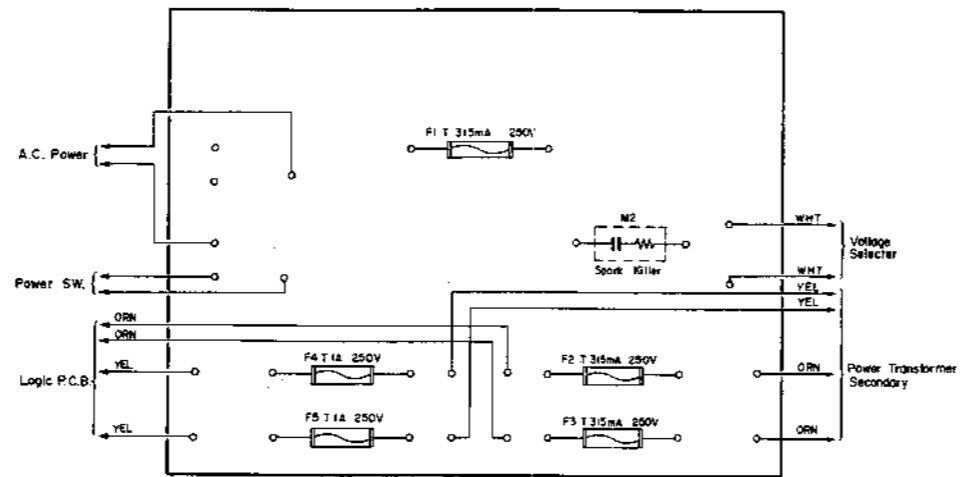

Fig. 7.6.2 Others

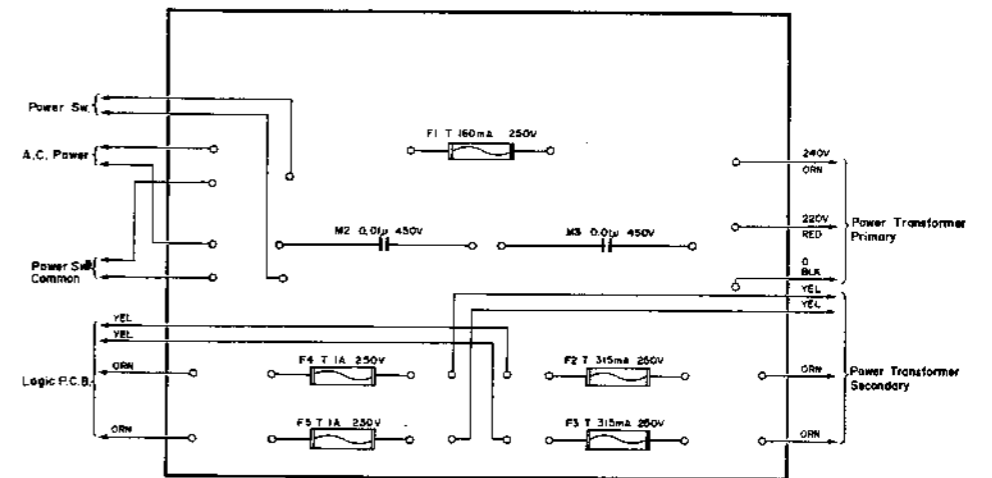

Fig. 7.6.4 220 V Class 2

Schematic Ref. No.	Part No.	Description
	0M04086A	Fuse Label 160mA (1 pce.)
	0M04131A	Fuse Label 1A x 2 (1 pce.)
	0M04074A	Fuse Label 315mA x 2 (1 pce.)
	0J03834B	Fuse P.C.B. Holder (1 pce.)
	0E00606A	Screw M3 x 6 Philips Pan Head (3A) (2 pcs.)
	0E00752A	Eyelet (6 pcs.)

7.7. Pin Jack P.C.B. Ass'y

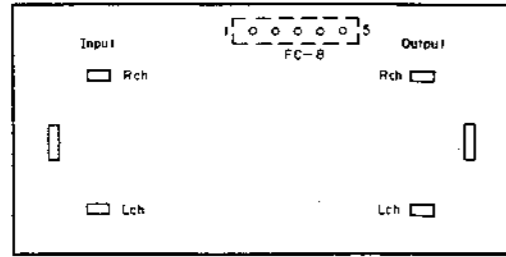

Fig. 7.7

7.8. Auto Shut-off P.C.B. Ass'y

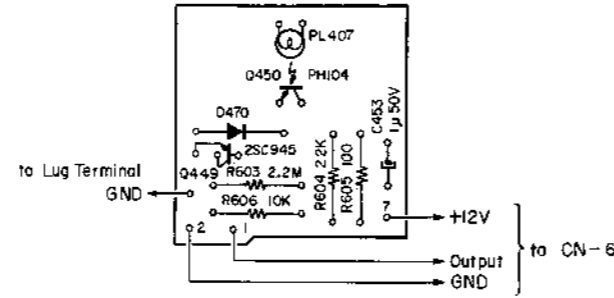

Fig. 7.8

Note: Diode is 1SS53 unless otherwise specified.

7.9. Volume P.C.B. Ass'y

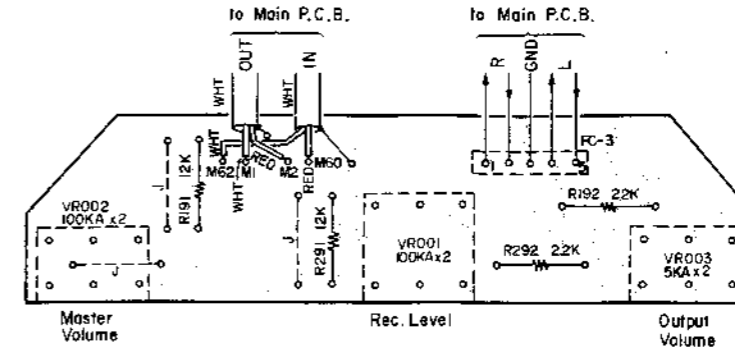

Fig. 7.9

Schematic Ref. No.	Part No.	Description	Schematic Ref. No.	Part No.	Description
FC8	BA04176A	Pin Jack P.C.B. Ass'y	D701,702	0B06181A	Silicon Diode 1SS53
	0B07835A	Pin Jack P.C.B.	801,802		
	0B05238A	5P Flat Cable 50mm	901,902		
	0B08709A	Jack Unit (1 pce.)	903,904		
	0E00037A	Earth Lug B-5 (1 pce.)	905,906		
Q449 Q450 D470 R603 R604 R605 R606 C453 PL407	BA04070A	Auto Shut-off P.C.B. Ass'y	VR901,902	0B09107A	Semi-fixed Volume 500K
	0B07839A	Auto Shut-off P.C.B.	R701,801	0B05625A	Carbon Resistor 220K ERD-25T J
	0B06228A	Transistor 2SC945 (L)	917,919		
	0B06181A	Photo Transistor PH104	R702,802	0B01889A	Carbon Resistor 100K ERD-25T J
	0B06181A	Silicon Diode 1SS53	929,930		
	0B05671A	Carbon Resistor 2.2M ERD-25T J	936,937		
	0B05615A	Carbon Resistor 22K ERD-25T J	R703,803	0B01888A	Carbon Resistor 10K ERD-25T J
	0B09215A	Fail Safe Type Resistor 100 RDF-25S J	R704,804	0B05627A	Carbon Resistor 330K ERD-25T J
	0B01888A	Carbon Resistor 10K ERD-25T J	904,927		
	0B01405A	Electrolytic Capacitor 1μ 50V	R705,706	0B05509A	Carbon Resistor 33K ERD-25T J
	0B08552A	Lamp 12V 25mA	805,806		
			905,906		
			907,909		
			910,925		
	VR001 VR002 VR003 R191,291 R192,292 FC3	BA04069A	Volume P.C.B. Ass'y	R707,807	0B05671A
0B07836A		Volume P.C.B.	920,923		
0B07231A		Volume 100K (A)x2	928		
0B07279A		Volume 100K (A)x2	R901,902	0B05776A	Carbon Resistor 1M ERD-25T J
0B07259A		Volume 5K (A)x2	903,918		
0B09263A		Carbon Resistor 12K ERD-25T J	R908	0B01681A	Carbon Resistor 3.3K ERD-25T J
0B05622A		Carbon Resistor 2.2K ERD-25T J	R911,912	0B01887A	Carbon Resistor 5.6K ERD-25T J
IC901,905 IC902 IC903 IC904 Q901,902 905,906 907,909 910,913 Q903 Q904 Q908	BA04208A	Azimuth P.C.B. Ass'y B	R914,916	0B05615A	Carbon Resistor 22K ERD-25T J
	0B07872A	Azimuth P.C.B.	924,931		
	0B06124B	IC RC4558D	R915	0B09380A	Carbon Resistor 1.5M ERD-25T J
	0B06216A	IC μPC4556C	R921	0B05692A	Carbon Resistor 68K ERD-25T J
	0B06213A	IC TC4013BP	R926	0B01682A	Carbon Resistor 6.8K ERD-25T J
	0B06244A	IC μPD4073C	R932	0B05626A	Carbon Resistor 150K ERD-25T J
	0B01872A	Transistor 2SC945(L)	R933	0B05641A	Carbon Resistor 47K ERD-25T J
			C701,801	0B01405A	Electrolytic Capacitor 1μ 50V
			901,902		
			C702,802	0B01412A	Electrolytic Capacitor 10μ 16V
		C704,804	0B01802A	Mylar Capacitor 2200P 50V J	
		C705,805	0B01676A	Mylar Capacitor 0.056μ 50V	
		C903	0B01389A	Electrolytic Capacitor 4.7μ 16V	
		C904	0B05772A	Tantalum Capacitor 0.22μ 35V	
		CN10	0B08656A	2P-T Post	

7.10. Auto Azimuth P.C.B. Ass'y

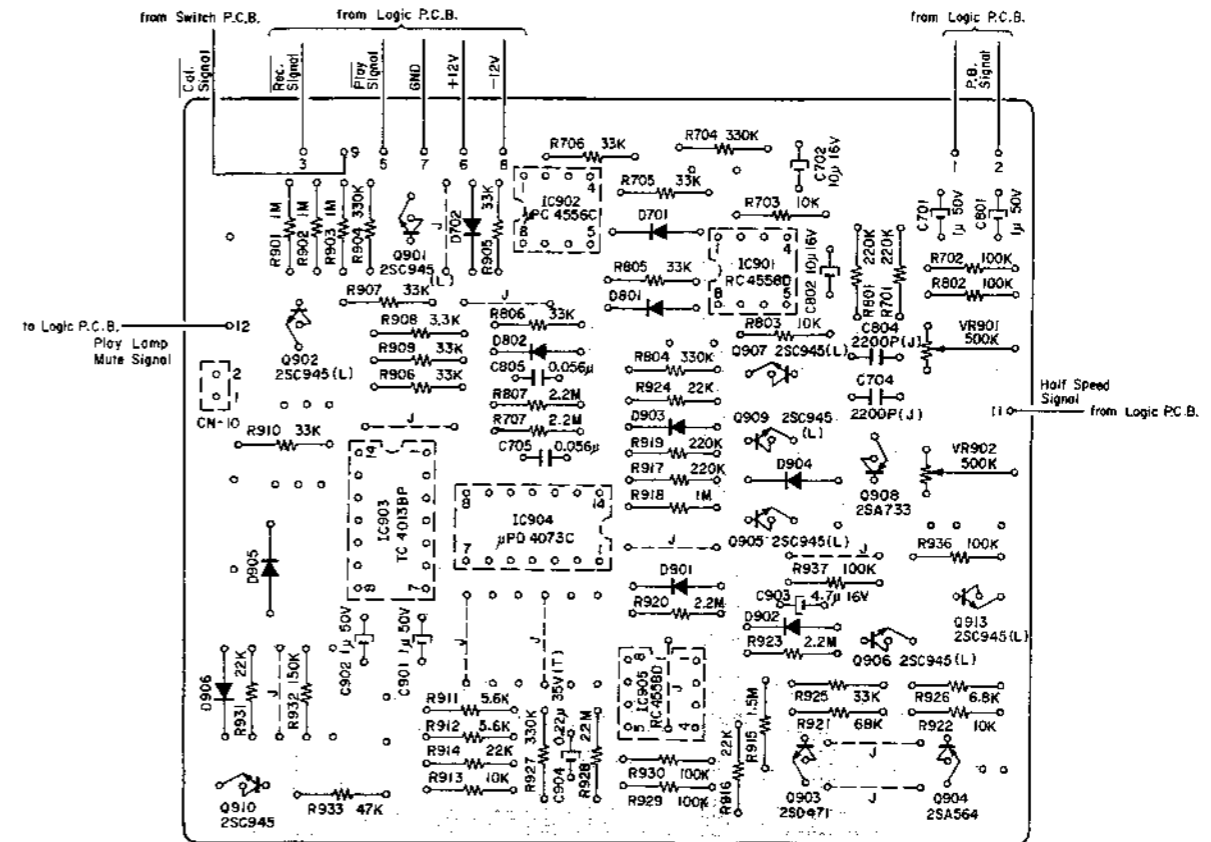

Fig. 7.10

7.11. Control Switch P.C.B. Ass'y

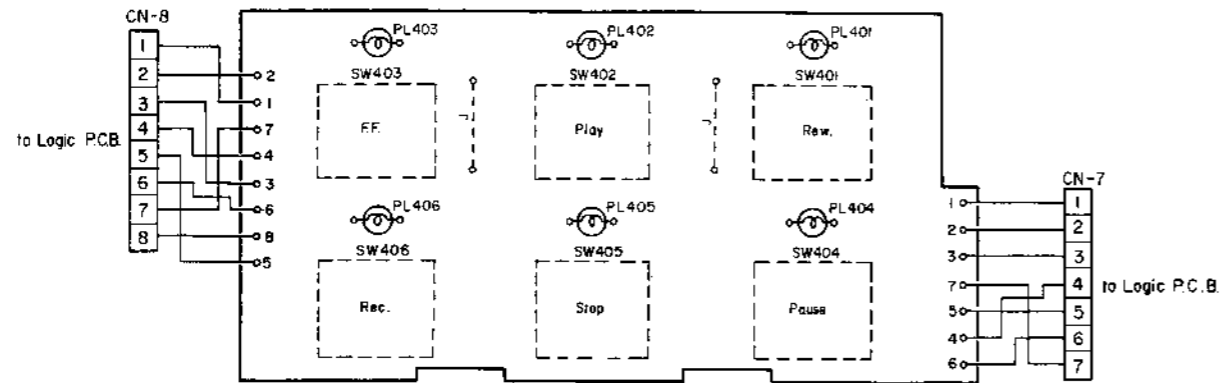

Fig. 7.11

7.12. Lamp P.C.B. A Ass'y

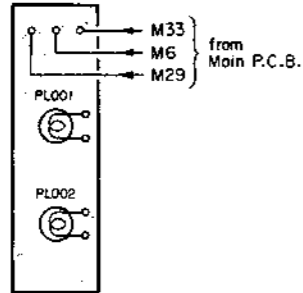

Fig. 7.12

7.13. Lamp P.C.B. B Ass'y

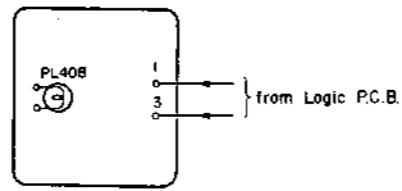

Fig. 7.13

7.14. Lamp P.C.B. C Ass'y

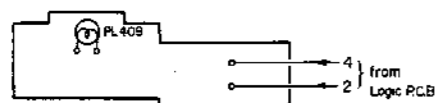

Fig. 7.14

Schematic Ref. No.	Part No.	Description	Schematic Ref. No.	Part No.	Description	
SW401-406 PL401-406 CN7 CN8	BA04071A	Control Switch P.C.B. Ass'y	PL408	BA04062A	Lamp P.C.B. B Ass'y	
	0B07832A	Control Switch P.C.B.		0B07838A	Lamp P.C.B. B	
	0B07219A	Semi-Switch	0B08586A	Lamp	12V 60mA	
	0B08552A	Lamp	12V 25mA	PL409	BA04063A	Lamp P.C.B. C Ass'y
	0B08631B	7P-H Connector A Ass'y	0B07840A		Lamp P.C.B. C	
0B08630B	8P-H Connector A Ass'y	0B08586A	Lamp		12V 60mA	
PL001, 002	BA04072A	Lamp P.C.B. A Ass'y				
	0B07837A	Lamp P.C.B. A				
	0B08552A	Lamp			12V 25mA	

7.15. Indicator P.C.B. A Ass'y

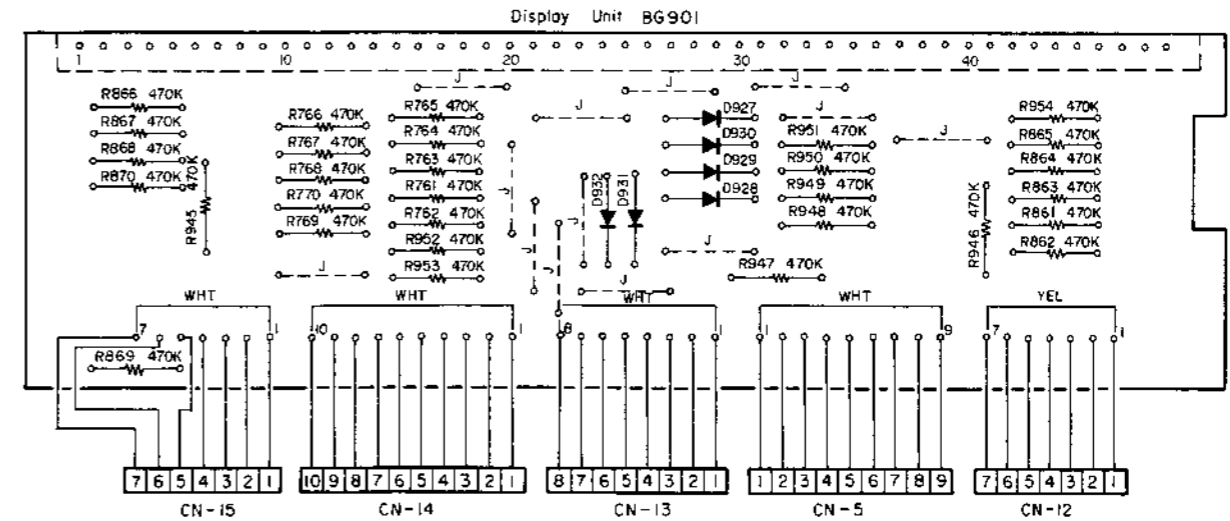

Fig. 7.15

Note: Diode is 1SS53 unless otherwise specified.

7.16. Indicator P.C.B. B Ass'y

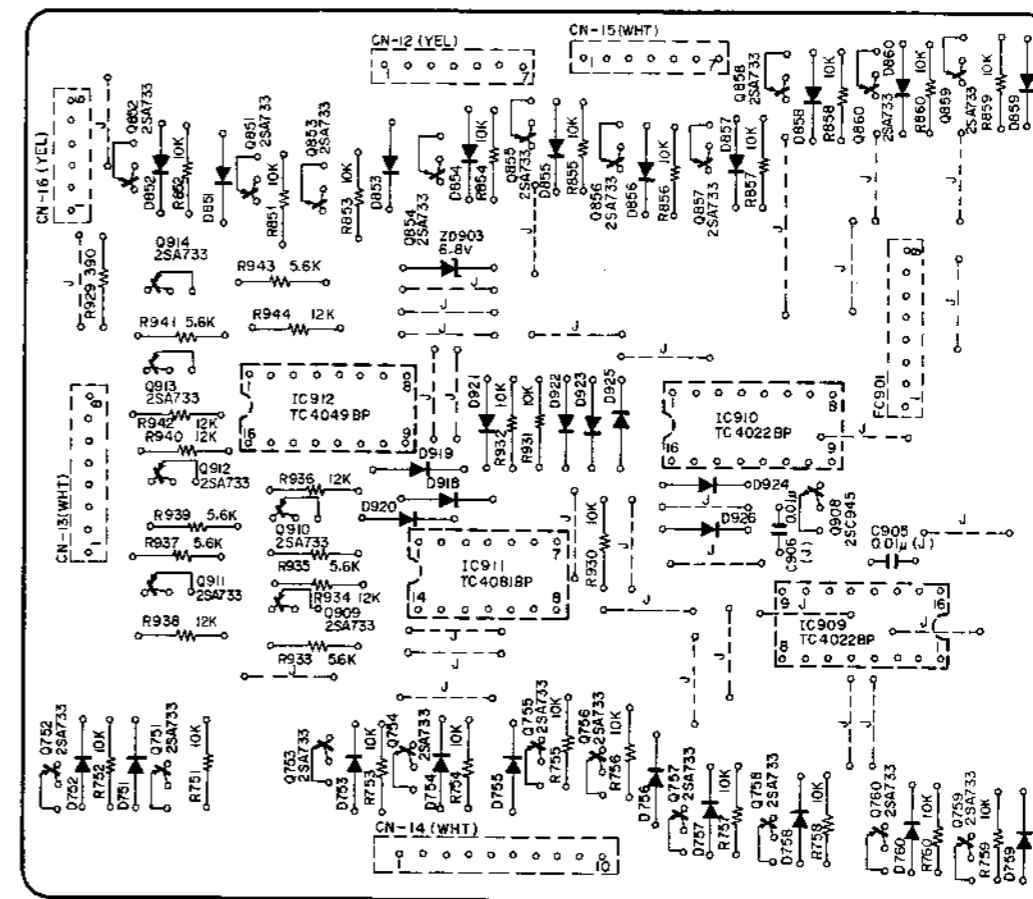

Fig. 7.16

Note: Diode is 1SS53 unless otherwise specified.

Schematic Ref. No.	Part No.	Description	Schematic Ref. No.	Part No.	Description
	BA04061A	Indicator P.C.B. A Ass'y		BA04066A	Indicator P.C.B. C Ass'y
D927-932	0B07829A	Indicator P.C.B. A	IC901	0B07831B	Indicator P.C.B. C
R761-770	0B06181A	Silicon Diode 1SS53 (6 pcs.)	IC902	0B06144A	IC μ PD4066C
861-870	0B01684A	Carbon Resistor 470K ERD-25T J (30 pcs.)	IC903	0B06219A	IC TC4081BP
945-954			IC904	0B06215A	IC TC4049BP
BG901	0B08640A	Display Unit FIP50A13Y	IC905	0B06217A	IC RC4560D
CN5	0B08638A	9P-H Connector Ass'y	IC906	0B06224A	IC TC4023BP
CN12	0B08636A	7P-H Connector C Ass'y	IC907	0B06178A	IC μ PD4011C
CN13	0B08637A	8P-H Connector B Ass'y	IC908	0B06223A	IC TC4040BP
CN14	0B08639A	10P-H Connector Ass'y	Q901, 904	0B06216A	IC RC4556C
CN15	0B08635A	7P-H Connector B Ass'y	Q902, 903	0B06100A	Transistor 2SC945
	BA04065A	Indicator P.C.B. B Ass'y	905, 906	0B06013A	Transistor 2SA733
	0B07830B	Indicator P.C.B. B	907		
IC909, 910	0B06218A	IC TC4022BP	ZD901	0B06230A	Zener Diode 5V
IC911	0B06219A	IC TC4081BP	ZD902	0B06233A	Zener Diode 10V
IC912	0B06215A	IC TC4049BP	D901-917	0B06181A	Silicon Diode 1SS53 (17 pcs.)
Q751-760	0B06013A	Transistor 2SA733 (26 pcs.)	VR901	0B07257A	Semi-fixed Volume 100K
851-860			R901, 907	0B01889A	Carbon Resistor 100K ERD-25T J
909-914			913, 914		
Q908	0B06100A	Transistor 2SC945	915		
D751-760	0B06181A	Silicon Diode 1SS53 (29 pcs.)	R902	0B05578A	Carbon Resistor 180 ERD-25T J
851-860			R903	0B01856A	Carbon Resistor 8.2K ERD-25T J
918-926			R904	0B09299A	Metal Film Resistor 511K SN14K2E F
ZD903	0B06241A	Zener Diode 6.8V	R905	0B09319A	Metal Film Resistor 36.5K SN14K2E F
R751-760	0B01888A	Carbon Resistor 10K ERD-25T J (23 pcs.)	R906	0B05509A	Carbon Resistor 33K ERD-25T J
851-860			R908, 916	0B01888A	Carbon Resistor 10K ERD-25T J
930-932			917, 920		
R929	0B05691A	Carbon Resistor 390 ERD-25T J	921, 922		
R933, 935	0B01887A	Carbon Resistor 5.6K ERD-25T J	923, 924		
937, 939			R909	0B09300A	Metal Film Resistor 150K SN14K2E F
941, 943			R910	0B09298A	Metal Film Resistor 64.9K SN14K2E F
R934, 936	0B09263A	Carbon Resistor 12K ERD-25T J	R911, 912	0B05743A	Carbon Resistor 27K ERD-25T J
938, 940			919		
942, 944			R918	0B05692A	Carbon Resistor 68K ERD-25T J
C905, 906	0B09290A	Ceramic Capacitor 0.01 μ 50V J	R925	0B01857A	Carbon Resistor 1K ERD-25T J
CN12, 15	0B08643A	7P-T Post	R926	0B05698A	Carbon Resistor 1.5K ERD-25T J
CN13	0B08644A	8P-T Post	R927	0B01682A	Carbon Resistor 6.8K ERD-25T J
CN14	0B08646A	10P-T Post	R928	0B09263A	Carbon Resistor 12K ERD-25T J
CN16	0B08642A	6P-T Post	C901	0B09191A	PP Capacitor 4700P 100V G
FC901	0B05239A	8P Flat Cable 50mm	C902	0B09312A	PP Capacitor 0.01 μ 100V G
			C903	0B09322A	PP Capacitor 330P 100V G
			C904	0B09290A	Ceramic Capacitor 0.01 μ 50V J
			CN4	0B08633A	6P-H Connector B Ass'y
			CN6	0B08634A	6P-H Connector C Ass'y
			CN16	0B08632A	6P-H Connector A Ass'y

7.17. Indicator P.C.B. C Ass'y

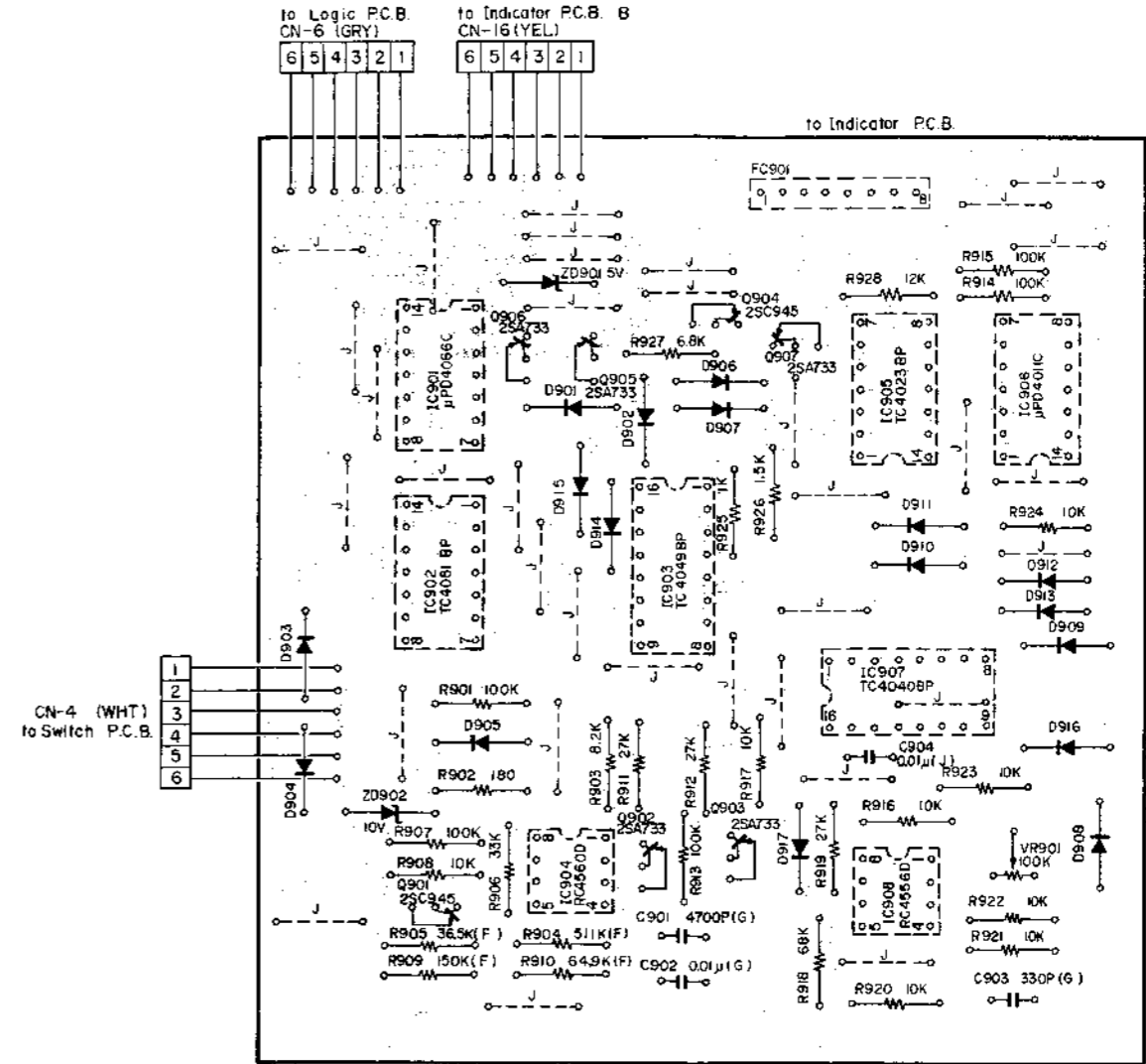

Fig. 7.17 Note: Diode is 1SS53 unless otherwise specified.

8. MECHANISM ASS'Y AND PARTS LIST

8.1. Synthesis

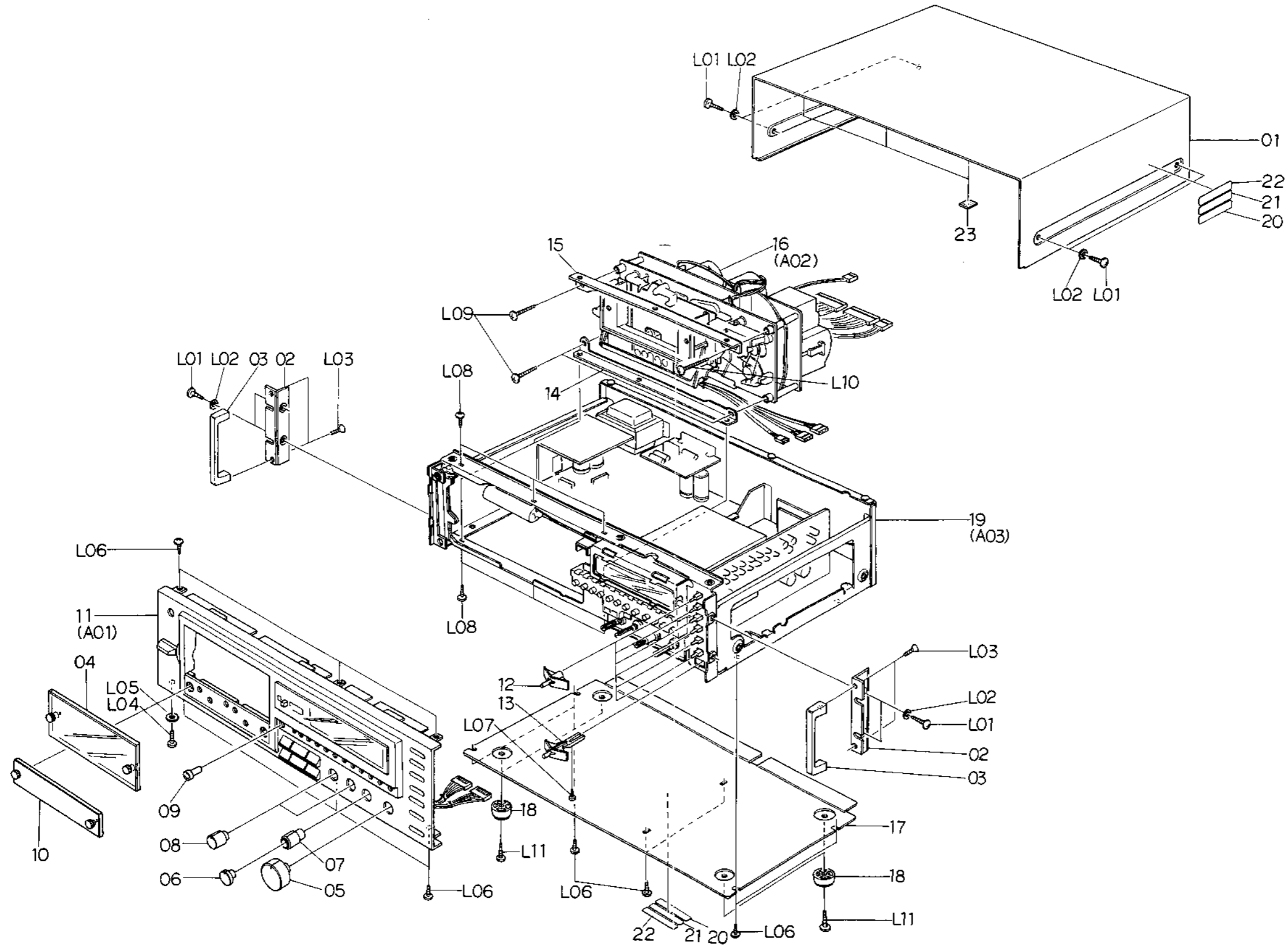

Fig. 8.1

Schematic Ref. No.	Part No.	Description	Q'ty	Schematic Ref. No.	Part No.	Description	Q'ty
		Synthesis Serial No.: A11606273 -				Synthesis Serial Nos.: A11606264 - A11606272	
01	0H03723D	Top Cover	1	01	0H03723D	Top Cover	1
02	0H03788B	Side Panel B	2	02	0H03788B	Side Panel B	2
03	0H03763B	Handle B	2	03	0H03763B	Handle B	2
04	HA03882A	Cassette Case Cover Ass'y	1	04	HA03882A	Cassette Case Cover Ass'y	1
05	0H03732B	Volume Knob A	1	05	0H03732B	Volume Knob A	1
(05)	0H03733A	Volume Knob Sleeve A	1	(05)	0H03733A	Volume Knob Sleeve A	1
06	0H03736B	Volume Knob L	1	06	0H03736B	Volume Knob L	1
(06)	0H03737A	Volume Knob Sleeve L	1	(06)	0H03737A	Volume Knob Sleeve L	1
07	0H03734B	Volume Knob R	1	07	0H03734B	Volume Knob R	1
(07)	0H03735A	Volume Knob Sleeve R	1	(07)	0H03735A	Volume Knob Sleeve R	1
08	0H03738B	Volume Knob B	2	08	0H03738B	Volume Knob B	2
(08)	0H03739A	Volume Knob Sleeve B	2	(08)	0H03739A	Volume Knob Sleeve B	2
09	0H03725A	Pitch Control Knob	1	09	0H03725A	Pitch Control Knob	1
10	HA03981A	Azimuth Alignment Cover Ass'y	1	10	HA03981A	Azimuth Alignment Cover Ass'y	1
11	HA03979A	Front Panel Ass'y	1	11	HA03979A	Front Panel Ass'y	1
12	HA03838B	Function Switch Knob Ass'y	6	12	HA03838B	Function Switch Knob Ass'y	6
13	0H03741A	Power Switch Knob	1	13	0H03741A	Power Switch Knob	1
14	0J04054B	Mechanism Holder B	1	14	0J04054B	Mechanism Holder B	1
15	0J04053A	Mechanism Holder A	1	15	0J04053A	Mechanism Holder A	1
16	CA08228A	Mechanism Ass'y 680ZX	1	16	CA08152C	Mechanism Ass'y 680ZX	1
17	0H03757A	Bottom Cover	1	17	0H03857A	Bottom Cover	1
18	0J03825A	Leg S	4	18	0J03825A	Leg S	4
19	JA03669A	Chassis Ass'y (U.S.A. & Canada)	1	19	JA03669A	Chassis Ass'y (U.S.A. & Canada)	1
	JA03670A	Chassis Ass'y (Japan)	1		JA03670A	Chassis Ass'y (Japan)	1
	JA03671A	Chassis Ass'y (220V Class 2)	1		JA03671A	Chassis Ass'y (220V Class 2)	1
	JA03672A	Chassis Ass'y (Australia)	1		JA03672A	Chassis Ass'y (Australia)	1
	JA03673A	Chassis Ass'y (UK)	1		JA03673A	Chassis Ass'y (UK)	1
	JA03674A	Chassis Ass'y (Others)	1		JA03674A	Chassis Ass'y (Others)	1
20	0M03799A	Caution Label G	1	20	0M03799A	Caution Label G	1
* 21	0M03800A	Caution Label H (U.S.A. & Canada)	2	* 21	0M03800A	Caution Label H (U.S.A. & Canada)	2
* 22	0M03883A	Lamp Caution Label (U.S.A. & Canada)	2	* 22	0M03883A	Lamp Caution Label (U.S.A. & Canada)	2
23	0J04080A	Top Cover Himeleon	4	23	0J04080A	Top Cover Himeleon	4
L01	0E00915A	BT Screw M4x8 Philips Binding Head (Black Chromate)	8	L01	0E00915A	BT Screw M4x8 Philips Binding Head (Black Chromate)	8
L02	0E00736A	Washer 4mm (Black Chromate)	8	L02	0E00736A	Washer 4mm (Black Chromate)	8
L03	0E00908A	Screw M4x6 Philips Countersunk	4	L03	0E00908A	Screw M4x6 Philips Countersunk	4
L04	0E00921A	BT Screw M3x8 Philips Binding Head (Black Chromate)	1	L04	0E00921A	BT Screw M3x8 Philips Binding Head (Black Chromate)	1
L05	0E00677A	Washer 3mm (Black Plastics)	1	L05	0E00677A	Washer 3mm (Black Plastics)	1
L06	0E00857A	BT Screw M3x6 Philips Binding Head	12	L06	0E00857A	BT Screw M3x6 Philips Binding Head	12
L07	0E00814A	ST Screw M2x4 Philips Pan Head	6	L07	0E00814A	ST Screw M2x4 Philips Pan Head	6
L08	0E00920A	Screw M3x6 Philips Polywave	1	L08	0E00920A	Screw M3x6 Philips Polywave	1
L09	0E00867A	BT Screw M4x15 Philips Binding Head	3	L09	0E00867A	BT Screw M4x15 Philips Binding Head	3
L10	0E00878A	BT Screw M4x20 Philips Binding Head	1	L10	0E00878A	BT Screw M4x20 Philips Binding Head	1
L11	0E00852A	BT Screw M4x12 Philips Binding Head	4	L11	0E00852A	BT Screw M4x12 Philips Binding Head	4
		*: Depends on the versions.				*: Depends on the versions.	

Schematic Ref. No.	Part No.	Description	Q'ty	Schematic Ref. No.	Part No.	Description	Q'ty
		Synthesis Serial Nos.: A11604671 - A11606263				Synthesis Serial Nos.: A11601001 - A11604670	
01	0H03723D	Top Cover	1	01	0H03723D	Top Cover	1
02	0H03788B	Side Panel B	2	02	0H03788B	Side Panel B	2
03	0H03763B	Handle B	2	03	0H03763B	Handle B	2
04	HA03882A	Cassette Case Cover Ass'y	1	04	HA03882A	Cassette Case Cover Ass'y	1
05	0H03732B	Volume Knob A	1	05	0H03732B	Volume Knob A	1
(05)	0H03733A	Volume Knob Sleeve A	1	(05)	0H03733A	Volume Knob Sleeve A	1
06	0H03736B	Volume Knob L	1	06	0H03736B	Volume Knob L	1
(06)	0H03737A	Volume Knob Sleeve L	1	(06)	0H03737A	Volume Knob Sleeve L	1
07	0H03734B	Volume Knob R	1	07	0H03734B	Volume Knob R	1
(07)	0H03735A	Volume Knob Sleeve R	1	(07)	0H03735A	Volume Knob Sleeve R	1
08	0H03738B	Volume Knob B	2	08	0H03738B	Volume Knob B	2
(08)	0H03739A	Volume Knob Sleeve B	2	(08)	0H03739A	Volume Knob Sleeve B	2
09	0H03725A	Pitch Control Knob	1	09	0H03725A	Pitch Control Knob	1
10	HA03981A	Azimuth Alignment Cover Ass'y	1	10	HA03981A	Azimuth Alignment Cover Ass'y	1
11	HA03979A	Front Panel Ass'y	1	11	HA03979A	Front Panel Ass'y	1
12	HA03838B	Function Switch Knob Ass'y	6	12	HA03838B	Function Switch Knob Ass'y	6
13	0H03741A	Power Switch Knob	1	13	0H03741A	Power Switch Knob	1
14	OJ04054B	Mechanism Holder B	1	14	OJ04054B	Mechanism Holder B	1
15	OJ04053A	Mechanism Holder A	1	15	OJ04053A	Mechanism Holder A	1
16	CA08152B	Mechanism Ass'y 680ZX	1	16	CA08152A	Mechanism Ass'y 680ZX	1
17	0H03757A	Bottom Cover	1	17	0H03757A	Bottom Cover	1
18	OJ03825A	Leg S	4	18	OJ03825A	Leg S	4
19	JA03669A	Chassis Ass'y (U.S.A. & Canada)	1	19	JA03669A	Chassis Ass'y (U.S.A. & Canada)	1
	JA03670A	Chassis Ass'y (Japan)	1		JA03670A	Chassis Ass'y (Japan)	1
	JA03671A	Chassis Ass'y (220V Class 2)	1		JA03671A	Chassis Ass'y (220V Class 2)	1
	JA03672A	Chassis Ass'y (Australia)	1		JA03672A	Chassis Ass'y (Australia)	1
	JA03673A	Chassis Ass'y (UK)	1		JA03673A	Chassis Ass'y (UK)	1
	JA03674A	Chassis Ass'y (Others)	1		JA03674A	Chassis Ass'y (Others)	1
20	0M03799A	Caution Label G	1	20	0M03799A	Caution Label G	1
*21	0M03800A	Caution Label H (U.S.A. & Canada)	2	*21	0M03800A	Caution Label H (U.S.A. & Canada)	2
*22	0M03883A	Lamp Caution Label (U.S.A. & Canada)	2	*22	0M03883A	Lamp Caution Label (U.S.A. & Canada)	2
23	OJ04080A	Top Cover Himelon	4	23	OJ04080A	Top Cover Himelon	4
L01	0E00915A	BT Screw M4x8 Philips Binding Head (Black Chromate)	8	L01	0E00915A	BT Screw M4x8 Philips Binding Head (Black Chromate)	8
L02	0E00736A	Washer 4mm (Black Chromate)	8	L02	0E00736A	Washer 4mm (Black Chromate)	8
L03	0E00908A	Screw M4x6 Philips Countersunk	4	L03	0E00908A	Screw M4x6 Philips Countersunk	4
L04	0E00921A	BT Screw M3x8 Philips Binding Head (Black Chromate)	1	L04	0E00921A	BT Screw M3x8 Philips Binding Head (Black Chromate)	1
L05	0E00677A	Washer 3mm (Black Plastics)	1	L05	0E00677A	Washer 3mm (Black Plastics)	1
L06	0E00857A	BT Screw M3x6 Philips Binding Head	12	L06	0E00857A	BT Screw M3x6 Philips Binding Head	12
L07	0E00814A	BT Screw M2x4 Philips Pan Head	6	L07	0E00814A	ST Screw M2x4 Philips Pan Head	6
L08	0E00920A	Screw M3x6 Philips Polywave	1	L08	0E00920A	Screw M3x6 Philips Polywave	1
L09	0E00867A	BT Screw M4x15 Philips Binding Head	3	L09	0E00867A	BT Screw M4x15 Philips Binding Head	3
L10	0E00878A	BT Screw M4x20 Philips Binding Head	1	L10	0E00878A	BT Screw M4x20 Philips Binding Head	1
L11	0E00852A	BT Screw M4x12 Philips Binding Head	4	L11	0E00852A	BT Screw M4x12 Philips Binding Head	4
		*: Depends on the versions.				*: Depends on the versions.	

8.2. Front Panel Ass'y (A01)

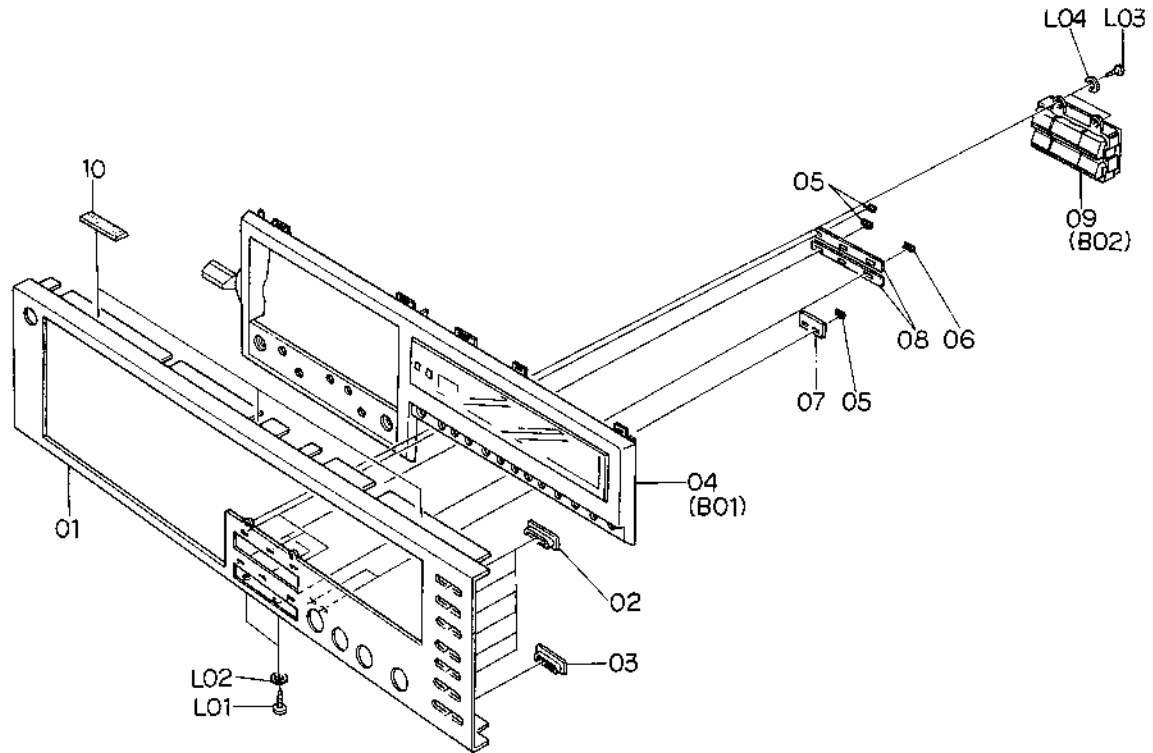

Fig. 8.2

Schematic Ref. No.	Part No.	Description	Q'ty
A01	HA03979A	Front Panel Ass'y Serial No.: A11601001 -	1
01	0H03824A	Front Panel	1
02	0H03746A	Function Switch Escutcheon	6
03	0H03747C	Power Switch Escutcheon	1
04	HA03978B	Front Panel Escutcheon Ass'y	1
05	0H03744B	Green Lens	7
06	0H03745B	Orange Lens	1
07	0J04060A	Light Intercepting Seal B	1
08	0J04059B	Light Intercepting Seal A	2
09	HA03823A	Control Button Ass'y	1
10	0H03781A	Cushion	3
L01	0E00825A	BT Screw M2.6x8 Philips Binding Head	2
L02	0E00912A	Washer FT25	2
L03	0E00794A	BT Screw M2x5 Philips Pan Head	2
L04	0E00117A	Washer 2mm	2

8.3. Mechanism Ass'y 680ZX (A02)

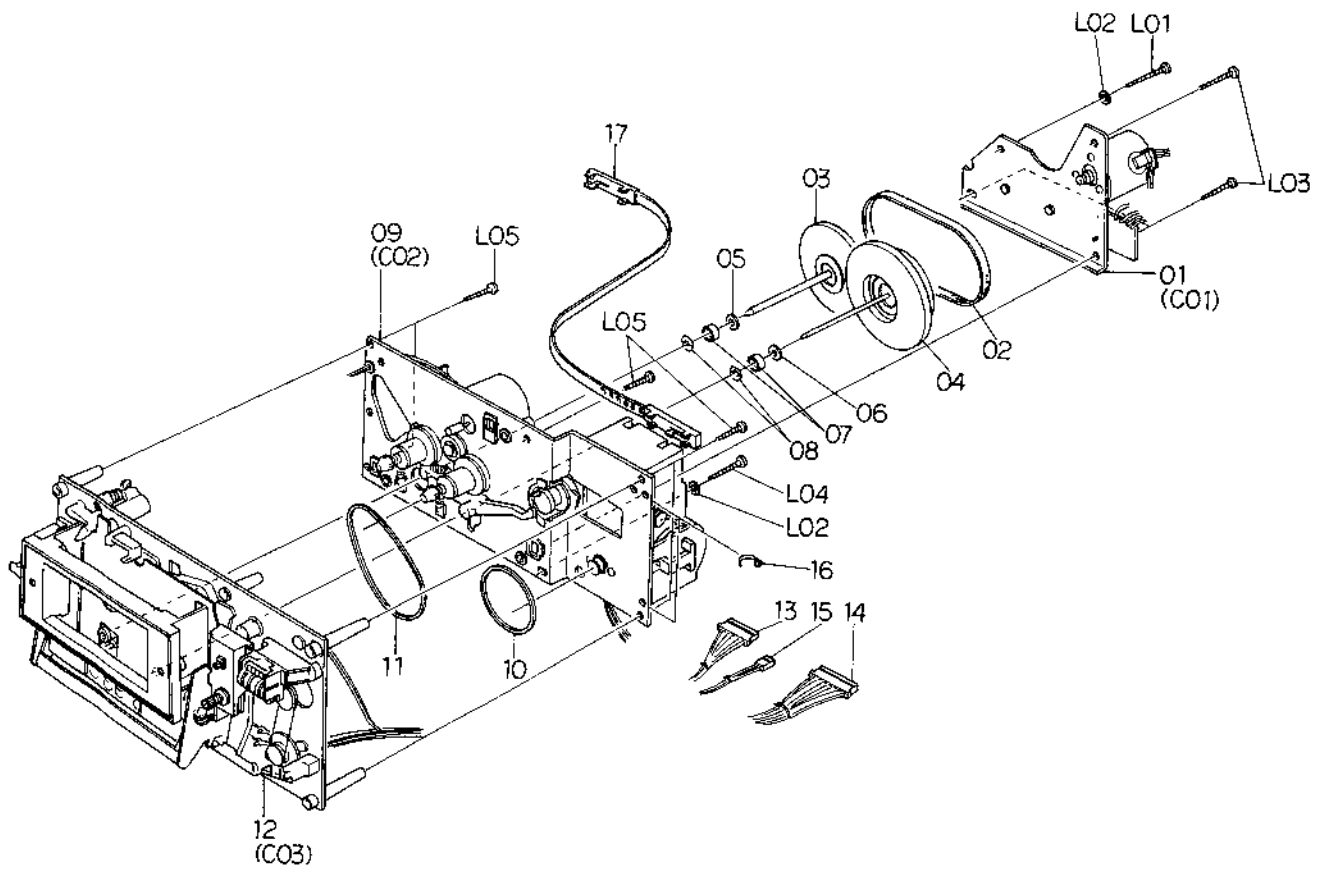

Fig. 8.3

Schematic Ref. No.	Part No.	Description	Q'ty	Schematic Ref. No.	Part No.	Description	Q'ty
A02	CA08228A	Mechanism Ass'y 680ZX Serial No.: A11606273 -	1	A02	CA08152B	Mechanism Ass'y 680ZX Serial Nos.: A11604671 - A11606263	1
01	CA08093A	Flywheel Holder Ass'y	1	01	CA08093A	Flywheel Holder Ass'y	1
02	0C08096C	Capstan Belt	1	02	0C08096C	Capstan Belt	1
03	CA08173A	Supply Flywheel Ass'y D	1	03	CA08173A	Supply Flywheel Ass'y D	1
04	CA08015A	Take-up Flywheel Ass'y	1	04	CA08015A	Take-up Flywheel Ass'y	1
05	0C08021B	Thrust Washer 3.1mm	1	05	0C08021B	Thrust Washer 3.1mm	1
06	0C08020B	Thrust Washer 2.6mm	1	06	0C08020B	Thrust Washer 2.6mm	1
07	0C08069C	Flange Thrust Cap	2	07	0C08069C	Flange Thrust Cap	2
08	0C08022B	Flange Thrust Spring	2	08	0C08022B	Flange Thrust Spring	2
09	CA08235A	Sub Mechanism Chassis Ass'y	1	09	CA08146A	Sub Mechanism Chassis Ass'y	1
10	0C08099B	Control Motor Belt	1	10	0C08099B	Control Motor Belt	1
11	0C08098B	Counter Belt B	1	11	0C08098B	Counter Belt B	1
12	CA08208A	Main Mechanism Chassis Ass'y	1	12	CA08181A	Main Mechanism Chassis Ass'y	1
13	0B08650B	9P-H Connector	1	13	0B08650B	9P-H Connector	1
14	0B08651D	11P-H Connector	1	14	0B08651D	11P-H Connector	1
15	0B08652C	3P-H Connector	1	15	0B08652C	3P-H Connector	1
16	0B08515A	Insh-Lock	15	16	0B08515A	Insh-Lock	15
17	0C08237A	Azimuth Alignment Wire	1	17	0C08237A	Azimuth Alignment Wire	1
-	0M04159A	Mechanism Serial No. Seal	1	-	0M04159A	Mechanism Serial No. Seal	1
L01	0E00834A	BT Screw M3x30 Philips Pan Head	1	L01	0E00834A	BT Screw M3x30 Philips Pan Head	1
L02	0E00178A	Washer 3mm	2	L02	0E00178A	Washer 3mm	2
L03	0E00833A	BT Screw M3x20 Philips Pan Head	3	L03	0E00833A	BT Screw M3x20 Philips Pan Head	3
L04	0E00835A	BT Screw M3x25 Philips Pan Head	1	L04	0E00835A	BT Screw M3x25 Philips Pan Head	1
L05	0E00883A	BT Screw M3x18 Philips Pan Head	5	L05	0E00883A	BT Screw M3x18 Philips Pan Head	5
A02	CA08152C	Mechanism Ass'y 680ZX Serial Nos.: A11606264 - A11606272	1	A02	CA08152A	Mechanism Ass'y 680ZX Serial Nos.: A11601001 - A11604670	1
01	CA08093A	Flywheel Holder Ass'y	1	01	CA08093A	Flywheel Holder Ass'y	1
02	0C08096C	Capstan Belt	1	02	0C08096C	Capstan Belt	1
03	CA08173A	Supply Flywheel Ass'y D	1	03	CA08014A	Supply Flywheel Ass'y	1
04	CA08015A	Take-up Flywheel Ass'y	1	04	CA08015A	Take-up Flywheel Ass'y	1
05	0C08021B	Thrust Washer 3.1mm	1	05	0C08021B	Thrust Washer 3.1mm	1
06	0C08020B	Thrust Washer 2.6mm	1	06	0C08020B	Thrust Washer 2.6mm	1
07	0C08069C	Flange Thrust Cap	2	07	0C08069C	Flange Thrust Cap	2
08	0C08022B	Flange Thrust Spring	2	08	0C08022B	Flange Thrust Spring	2
09	CA08202A	Sub Mechanism Chassis Ass'y	1	09	CA08146A	Sub Mechanism Chassis Ass'y	1
10	0C08099B	Control Motor Belt	1	10	0C08099B	Control Motor Belt	1
11	0C08098B	Counter Belt B	1	11	0C08098B	Counter Belt B	1
12	CA08208A	Main Mechanism Chassis Ass'y	1	12	CA08161A	Main Mechanism Chassis Ass'y	1
13	0B08650B	9P-H Connector	1	13	0B08650B	9P-H Connector	1
14	0B08651D	11P-H Connector	1	14	0B08651D	11P-H Connector	1
15	0B08652C	3P-H Connector	1	15	0B08652C	2P-H Connector	1
16	0B08515A	Insh-Lock	15	16	0B08515A	Insh-Lock	15
17	0C08237A	Azimuth Alignment Wire	1	17	0C08237A	Azimuth Alignment Wire	1
-	0M04159A	Mechanism Serial No. Seal	1	-	0M04159A	Mechanism Serial No. Seal	1
L01	0E00834A	BT Screw M3x30 Philips Pan Head	1	L01	0E00834A	BT Screw M3x30 Philips Pan Head	1
L02	0E00178A	Washer 3mm	2	L02	0E00178A	Washer 3mm	2
L03	0E00833A	BT Screw M3x20 Philips Pan Head	3	L03	0E00833A	BT Screw M3x20 Philips Pan Head	3
L04	0E00835A	BT Screw M3x25 Philips Pan Head	1	L04	0E00835A	BT Screw M3x25 Philips Pan Head	1
L05	0E00883A	BT Screw M3x18 Philips Pan Head	5	L05	0E00883A	BT Screw M3x18 Philips Pan Head	5

Schematic Ref. No.	Part No.	Description	Q'ty	Schematic Ref. No.	Part No.	Description	Q'ty				
A03	JA03669A	Chassis Ass'y (U.S.A. & Canada)	1	B01	HA03978B	Front Panel Escutcheon Ass'y Serial No.: A11601001 -	1				
	JA03670A	Chassis Ass'y (Japan)	1								
	JA03671A	Chassis Ass'y (220V Class 2)	1								
	JA03672A	Chassis Ass'y (Australia)	1								
	JA03673A	Chassis Ass'y (UK)	1								
	JA03674A	Chassis Ass'y (Others)	1	01	HA03984C	Front Panel Escutcheon Sub Ass'y	1				
		Serial No.:		02	0H03722B	Display Glass	1				
		A11601001 -		03	0H03743B	Counter Escutcheon	1				
01	JA03587A	FL Indicator Ass'y	1	04	0H03748A	FL Indicator Filter	1				
02	JA03675A	Calibration Case Ass'y	1	05	0J04050A	Counter Escutcheon Holder	1				
03	JA03589A	Volume Holder Ass'y	1	06	0H03749A	Memory Switch Knob	1				
04	JA03659A	Headphone Jack Ass'y	1	07	0J04043A	Memory Switch Knob Spring	1				
05	JA03600A	Reflector Ass'y	1	08	0H03753D	Counter Reset Knob Holder	1				
06	JA03602A	Counter Lamp Ass'y	1	09	0H03750A	Counter Reset Knob	1				
07	JA04034F	Front Chassis	1	10	0J04042A	Counter Reset Knob Spring	1				
08	BA04059B	Switch P.C.B. Ass'y	1	11	0H03724F	Eject Lever	1				
09	BA04058C	Main P.C.B. Ass'y	1	12	0H03762A	Eject Lever Spring	1				
10	BA04210A	Logic P.C.B. Ass'y	1	13	0J04057B	Eject Lever Cushion	1				
11	BA04208A	Auto Azimuth P.C.B. Ass'y	1	L01	0E00842A	Stopper Ring 2mm	5				
12	0J04033C	Side Chassis Right	1	L02	0E00854A	BT Screw M2.6x4 Philips Pan Head	2				
13	JA03592A	Power Switch Holder Ass'y (U.S.A., Canada & Others)	1	L03	0E00890A	C-Ring 2mm	1				
	JA03595A	Power Switch Holder Ass'y (Japan)	1	L04	0E00837A	Stopper Ring 3mm	1				
	JA03594A	Power Switch Holder Ass'y (220V Class 2, Australia & UK)	1	B02	HA03823A	Control Button Ass'y Serial No.: A11601001 -	1				
14	0J04055B	Switch P.C.B. Holder	1					01	0H03726B	Control Button Stop	1
15	0J04032C	Center Chassis	1					02	0H03727B	Control Button Play	1
16	0J04031B	Side Chassis Left	1					03	0H03728B	Control Button F.F.	1
17	HA03972A	Rear Panel Ass'y (U.S.A. & Canada)	1					04	0H03729B	Control Button Rewind	1
	HA03973A	Rear Panel Ass'y (Japan)	1					05	0H03730B	Control Button Pause	1
	HA03977A	Rear Panel Ass'y (220V Class 2)	1					06	0H03731B	Control Button Record	1
	HA03976A	Rear Panel Ass'y (Australia)	1					07	0J04044C	Control Button Holder	1
	HA03975A	Rear Panel Ass'y (UK)	1					08	0J04045B	Control Button Shaft	2
	HA03974A	Rear Panel Ass'y (Others)	1					09	0J04046A	Control Button Spring	6
18	0J04062B	Insulator	2					10	0J04052B	Spring Stopper	6
19	0B08515A	Insu-Lock	23					11	0J04099A	Control Button Himelon	2
20	0J04064A	Free Bushing 85mm	1					12	BA04071A	Control Switch P.C.B. Ass'y	1
*21	0M03700A	Earth Mark Label	1	L01	0E00792A	BT Screw M2.6x6 Philips Pan Head	6				
22	0B08580A	Wire Holder 161	1	L02	0J04061A	Washer FT20	8				
L01	0E00857A	BT Screw M3x6 Philips Binding Head	38	C01	CA08093A	Flywheel Holder Ass'y Serial No.: A11601001 -	1				
L02	0E00868A	BT Screw M3x8 Philips Binding Head	2					01	0C08013I	Flywheel Holder	1
L03	0E00859A	BT Screw M2.6x6 Philips Binding Head	3					02	0C08213A	Capstan Motor	1
L04	0E00622A	Screw M3x5 Philips Pan Head (2A)	6					03	0C08228B	Capstan Motor Pulley	1
L05	0E00860A	BT Screw M3x6 Philips Binding Head (Black Chromate)	6					04	-	Speed Cal. P.C.B. Ass'y (incorporated in the Capstan Motor)	(1)
L06	0E00157A	Washer 3mm (Black Plastics)	6					L01	0E00226A	Screw M2.6x4 Philips Pan Head	3
*L07	0E00521A	Screw M3x8 Philips Pan Head	1					L02	0C08068C	Thrust Screw	2
*L08	0E00507A	Nut Hex. M3	1					L03	0C03857A	Lock Nut	2
*L09	0E00581A	Washer 3mm (Spring)	1					L04	0E00862A	BT Screw M3x6 Philips Pan Head	1
*L10	0E00037A	Earth Lug B-5	1								

*: Depends on the versions.

8.4. Chassis Ass'y (A03)

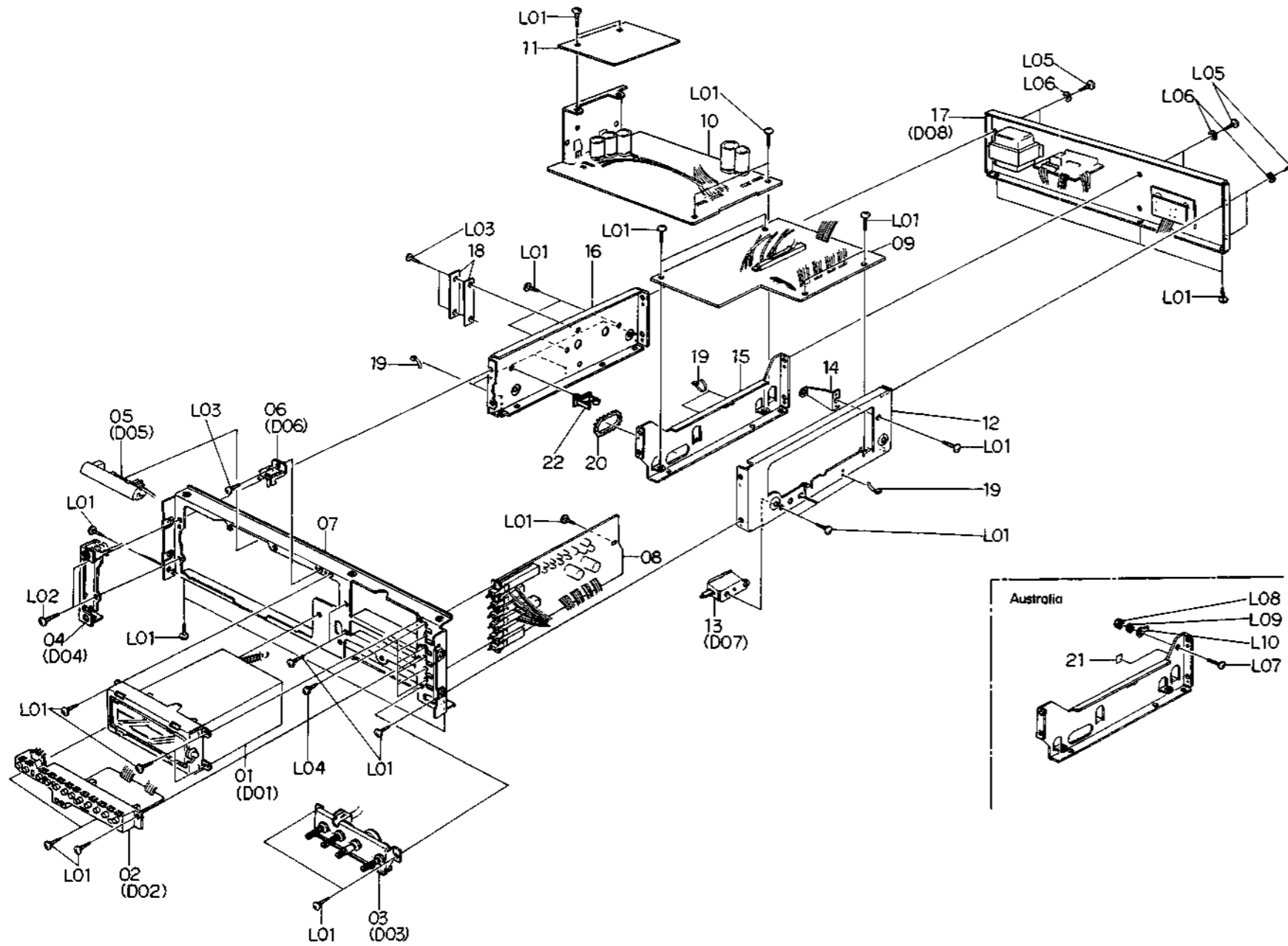

Fig. 8.4

8.5. Front Panel Escutcheon Ass'y (B01)

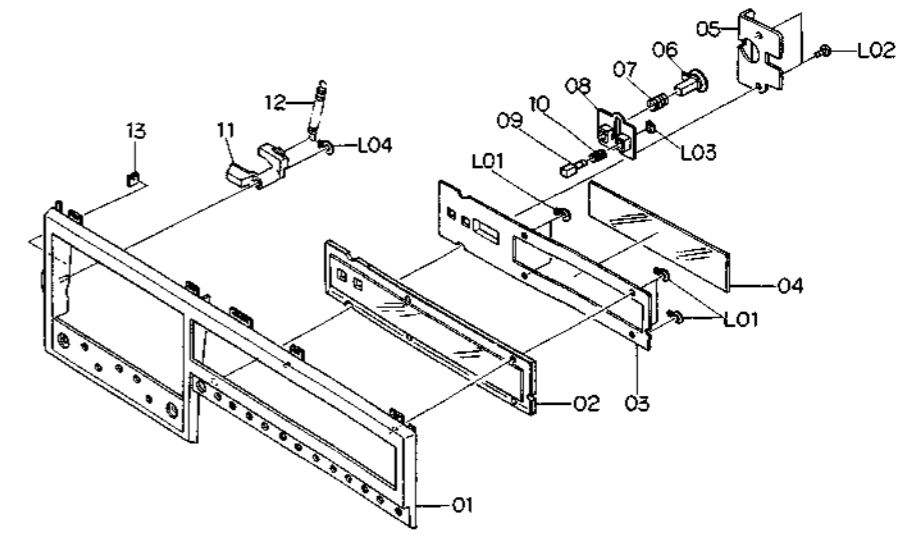

Fig. 8.5

8.6. Control Button Ass'y (B02)

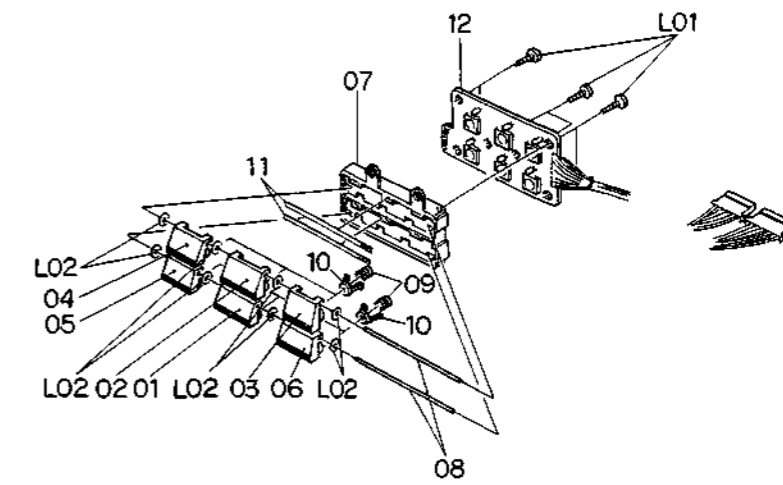

Fig. 8.6

8.7. Flywheel Holder Ass'y (C01)

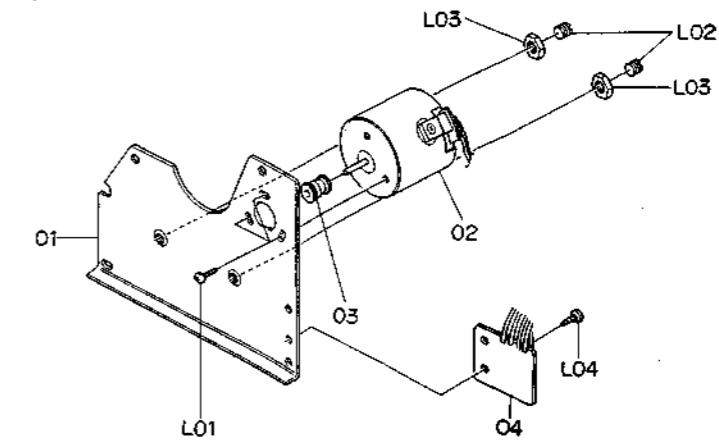

Fig. 8.7

8.8. Sub Mechanism Chassis Ass'y (C02)

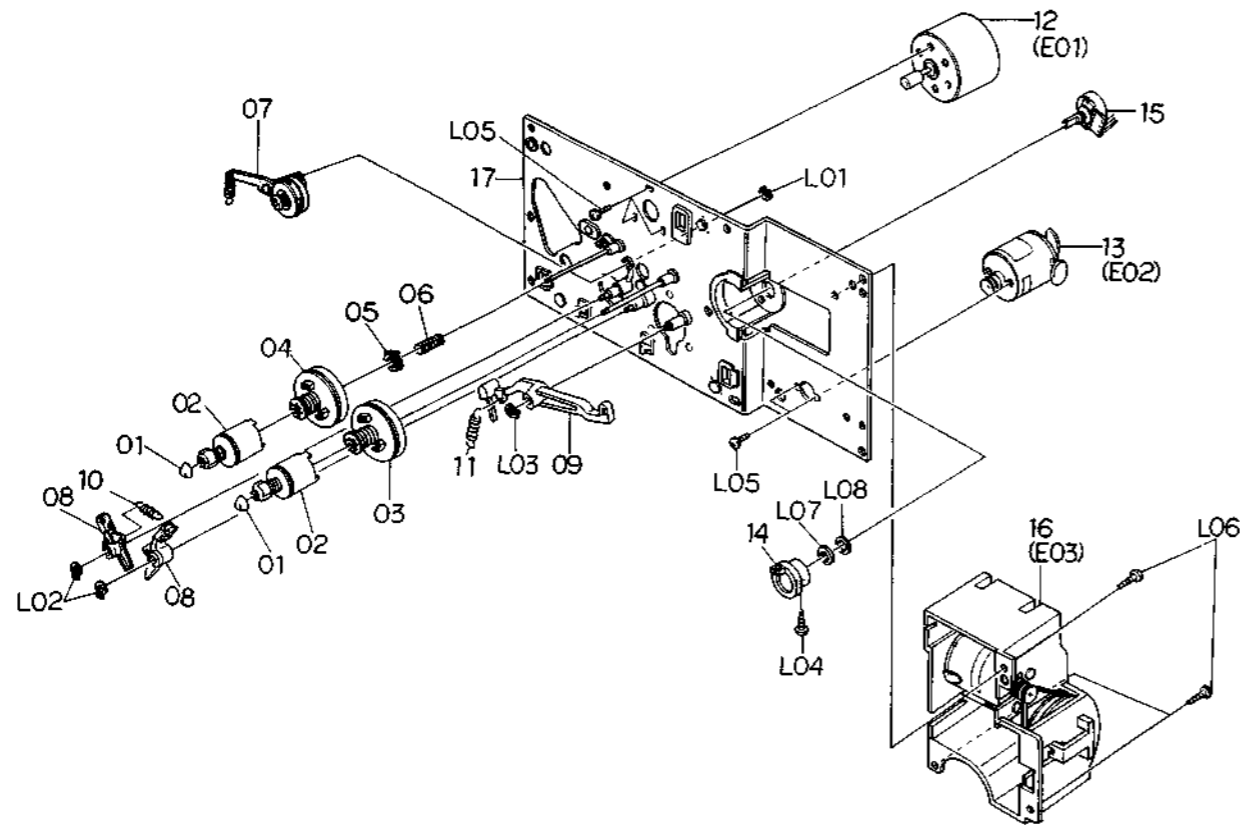

Fig. 8.8.1 Serial No.: A11606273 -

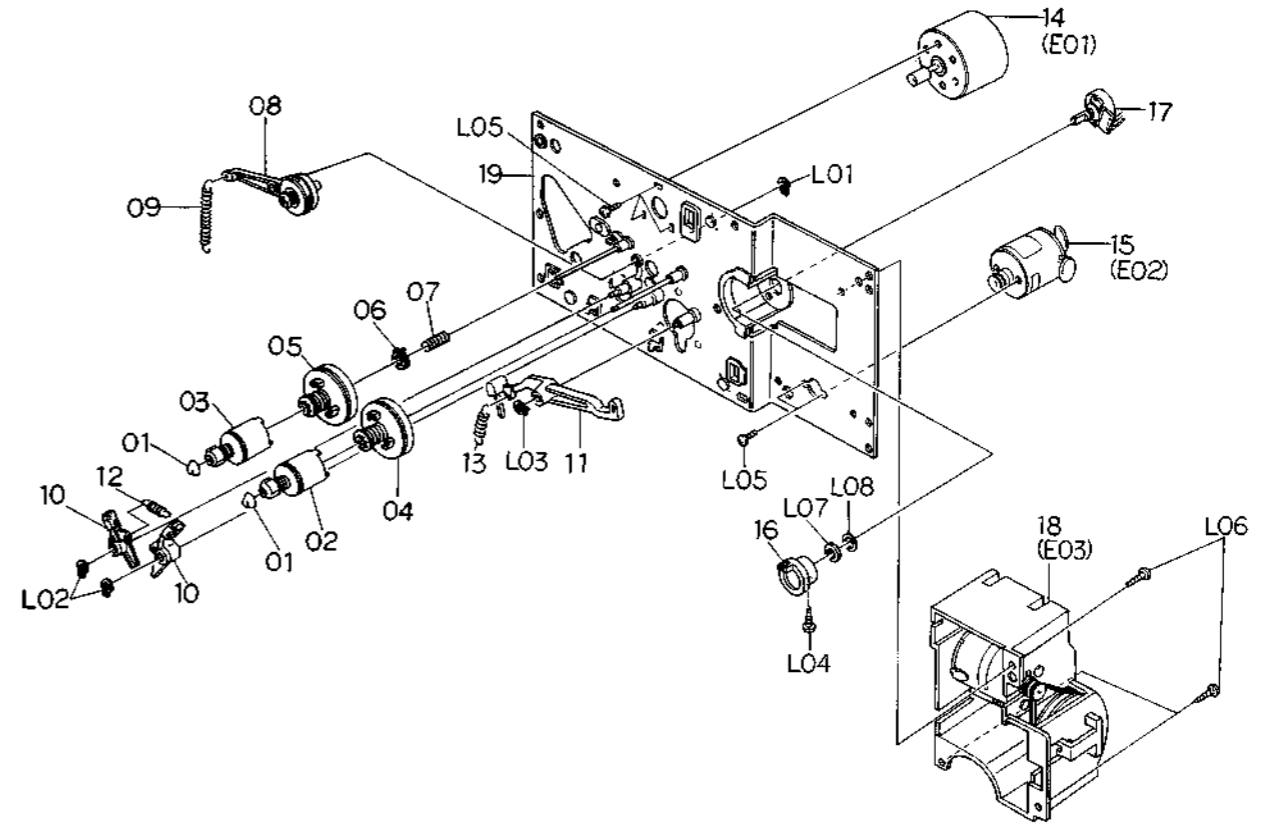

Fig. 8.8.2 Serial Nos.: A11606264 - A11606272

Schematic Ref. No.	Part No.	Description	Q'ty	Schematic Ref. No.	Part No.	Description	Q'ty	Schematic Ref. No.	Part No.	Description	Q'ty	Schematic Ref. No.	Part No.	Description	Q'ty
C02	CA08235A	Sub Mechanism Chassis Ass'y Serial No.: A11606273 -	1	L05	0E00226A	Screw M2.6x4 Philips Pan Head	5	C02	CA08202A	Sub Mechanism Chassis Ass'y Serial Nos.: A11606264 - A11606272	1	L04	0E00859A	BT Screw M2.6x6 Philips Binding Head	1
				L06	0E00846A	BT Screw M3x8 Philips Pan Head	3					L05	0E00226A	Screw M2.6x4 Philips Pan Head	5
01	0C08039B	Reel Hub Head	2	L07	-	Volume Nut	(1)	01	0C08039B	Reel Hub Head	2	L06	0E00846A	BT Screw M3x8 Philips Pan Head	3
02	CA08038C	Reel Hub B Ass'y	2	L08	-	Volume Washer	(1)	02	CA08038B	Reel Hub B Ass'y	1	L07	-	Volume Nut	(1)
03	CA08037A	Reel Hub Take-up Ass'y	1					03	CA08197A	Reel Hub B Ass'y	1	L08	-	Volume Washer	(1)
04	CA08064A	Reel Hub Supply Ass'y	1					04	CA08037A	Reel Hub Take-up Ass'y	1				
05	CA08039A	Back Tension Ass'y	1					05	CA08064A	Reel Hub Supply Ass'y	1				
06	0C08178A	Back Tension Spring	1					06	CA08039A	Back Tension Ass'y	1				
07	CA08193A	Idler Ass'y	1					07	0C08178A	Back Tension Spring	1				
08	CA08042A	Brake Ass'y	2					08	CA08040A	Idler Ass'y	1				
09	0C08030C	Brake Drive Arm	1					09	0C08127B	Idler Arm Spring	1				
10	0C08129A	Brake Arm Spring	1					10	CA08042A	Brake Ass'y	2				
11	0C08128A	Brake Drive Arm Spring	1					11	0C08030C	Brake Drive Arm	1				
12	CA08117B	Reel Motor Ass'y	1					12	0C08129A	Brake Arm Spring	1				
13	CA08034A	Control Motor Ass'y	1					13	0C08128A	Brake Drive Arm Spring	1				
14	0C08053B	Volume Coupler	1					14	CA08117B	Reel Motor Ass'y	1				
15	0B07240A	Volume Control 10kΩ (B)	1					15	CA08034A	Control Motor Ass'y	1				
16	CA08148A	Azimuth Alignment Motor Ass'y	1					16	0C08053B	Volume Coupler	1				
17	CA08041A	Sub Chassis Ass'y	1					17	0B07240A	Volume Control 10kΩ (B)	1				
L01	0E00698A	E-Ring 2.5mm	1					18	CA08148A	Azimuth Alignment Motor Ass'y	1				
L02	0E00837A	Stopper Ring 3mm	2					19	CA08041A	Sub Chassis Ass'y	1				
L03	0E00838A	Stopper Ring 4mm	1					L01	0E00842A	Stopper Ring 2mm	1				
L04	0E00859A	BT Screw M2.6x6 Philips Binding Head	1					L02	0E00837A	Stopper Ring 3mm	2				
								L03	0E00838A	Stopper Ring 4mm	1				

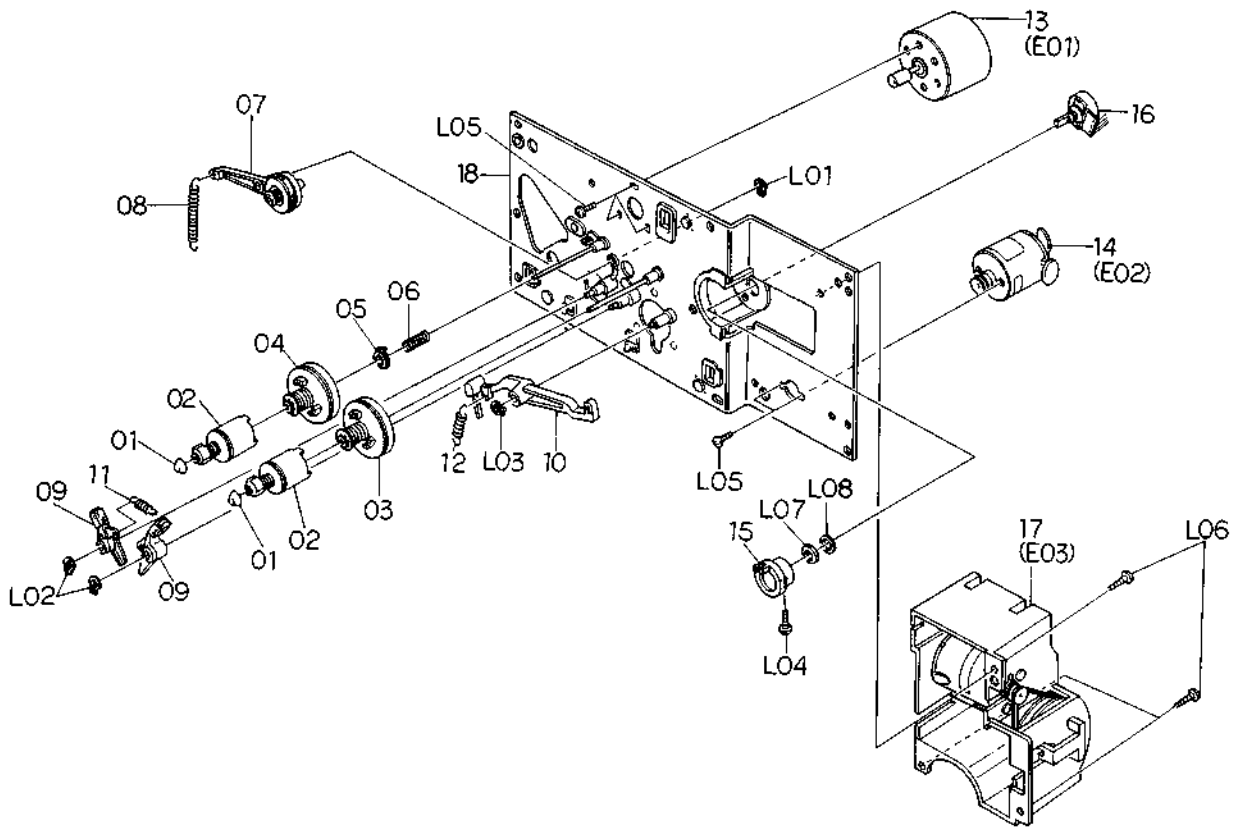

Fig. 8.8.3 Serial Nos.: A11601001 – A11606263

Schematic Ref. No.	Part No.	Description	Q'ty	Schematic Ref. No.	Part No.	Description	Q'ty
C02	CA08146A	Sub Mechanism Chassis Ass'y Serial Nos.: A11601001 – A11606263	1	L04	0E00859A	BT Screw M2.6x6 Philips Binding Head	1
				L05	0E00226A	Screw M2.6x4 Philips Pan Head	5
01	0C08039B	Reel Hub Head	2	L06	0E00846A	BT Screw M3x8 Philips Pan Head	3
02	CA08038B	Reel Hub B Ass'y	2	L07	-	Volume Nut	(1)
03	CA08037A	Reel Hub Take-up Ass'y	1	L08	-	Volume Washer	(1)
04	CA08064A	Reel Hub Supply Ass'y	1				
05	CA08039A	Back Tension Ass'y	1				
06	0C08178A	Back Tension Spring	1				
07	CA08040A	Idler Ass'y	1				
08	0C08127B	Idler Arm Spring	1				
09	CA08042A	Brake Ass'y	2				
10	0C08030C	Brake Drive Arm	1				
11	0C08129A	Brake Arm Spring	1				
12	0C08128A	Brake Drive Arm Spring	1				
13	CA08117B	Reel Motor Ass'y	1				
14	CA08034A	Control Motor Ass'y	1				
15	0C08053B	Volume Coupler	1				
16	0B07240A	Volume Control 10kΩ (B)	1				
17	CA08148A	Azimuth Alignment Motor Ass'y	1				
18	CA08041A	Sub Chassis Ass'y	1				
L01	0E00842A	Stopper Ring 2mm	1				
L02	0E00837A	Stopper Ring 3mm	2				
L03	0E00838A	Stopper Ring 4mm	1				

680ZX

Schematic Ref. No.	Part No.	Description	Q'ty	Schematic Ref. No.	Part No.	Description	Q'ty
C03	CA08208A	Main Mechanism Chassis Ass'y Serial No.: A11606264 -	1	L12	0E00846A	BT Screw M3x8 Philips Pan Head	3
				L13	0E00865A	BT Screw M3x10 Philips Binding Head	2
01	CA08125A	Cassette Case Holder L Ass'y	1	L14	0E00895A	Earth Lug 3mm	2
02	0C08151A	Lid Arm Spring Tube	1	L15	0E00859A	BT Screw M2.6x6 Philips Binding Head	1
03	CA08022A	Cassette Case Holder R Ass'y	1	L16	0C08255A	Washer 2.6mm	1
04	CA08163A	Cassette Case Ass'y	1				
05	0C08019I	Cover Plate	1				
06	0M03977A	Cassette Viewer Label	1				
07	CA08160A	Head Mount Base Ass'y	1				
08	0C08121A	Supply Pressure Roller Spring	1				
09	CA08053B	Supply Pressure Roller Ass'y	1				
10	0C08122B	Supply Pressure Roller Thrust Spring	1				
11	CA08079B	Take-up Pressure Roller Ass'y	1				
12	0C08183B	Take-up Pressure Roller Thrust Spring	1				
13	CA08104A	Head Base Ass'y D	1				
14	0C08182A	Pressure Roller Drive Bar B	1				
15	0C08086B	Head Base Roller	3				
16	0C08050B	Record Sensor	1				
17	0C08051E	Cassette Hold Arm	1				
18	0C08120A	Cassette Hold Arm Spring	1				
19	CA08027A	Head Base Drive Arm Ass'y	1				
20	0C08143C	Head Base Drive Arm Spring	1				
21	CA08026A	Pressure Roller Drive Arm Ass'y	1				
22	CA08099A	Auto Shut-off Ass'y	1				
23	CA08098A	Counter Ass'y	1				
24	CA08105A	Pitch Control Holder Ass'y	1				
25	0C08224A	Counter Belt	1				
26	0C08119A	Record Protector	1				
27	0C08194C	Damper Lock Arm	1				
28	0C08153A	Dampe Lock Arm Spring Tube	1				
29	0C08126A	Damper Lock Arm Spring	1				
30	CA08030A	Pneumatic Damper Ass'y	1				
31	CA08023A	Supply Capstan Flange Ass'y	1				
32	CA08024A	Take-up Capstan Flange Ass'y	1				
33	0C08186A	Cam Drive Gear	1				
34	0C08029H	Control Cam	1				
35	0C08152A	Counter-Load Arm Spring	1				
36	0C08117A	Counter-Load Arm Spring Tube	1				
37	CA08028A	Counter-Load Arm Ass'y	1				
38	CA08072A	Main Chassis Ass'y	1				
39	0C08250A	Supply Pressure Roller Spring B	1				
40	CA08196A	Back Tension Ass'y	1				
41	0C08254A	Back Tension Arm Collar	1				
L01	0E00837A	Stopper Ring 3mm	7				
L02	0E00832A	BT Screw M3x14 Philips Pan Head	2				
L03	0E00834A	BT Screw M3x30 Philips Pan Head	2				
L04	0E00831A	BT Screw M3x10 Philips Pan Head	3				
L05	0E00254A	Washer 3.1mm (Plastics)	2				
L06	0E00222A	E-Ring 2mm	2				
L07	0E00876A	BT Screw M2.6x8 Philips Pan Head	11				
L08	0C08060B	Height Adjustment Nut	2				
L09	0E00142A	Washer 2.6mm	2				
L10	0E00879A	BT Screw M2x15 Philips Pan Head	1				
L11	0E00838A	Stoppe Ring 4mm	3				

8.9. Main Mechanism Chassis Ass'y (C03)

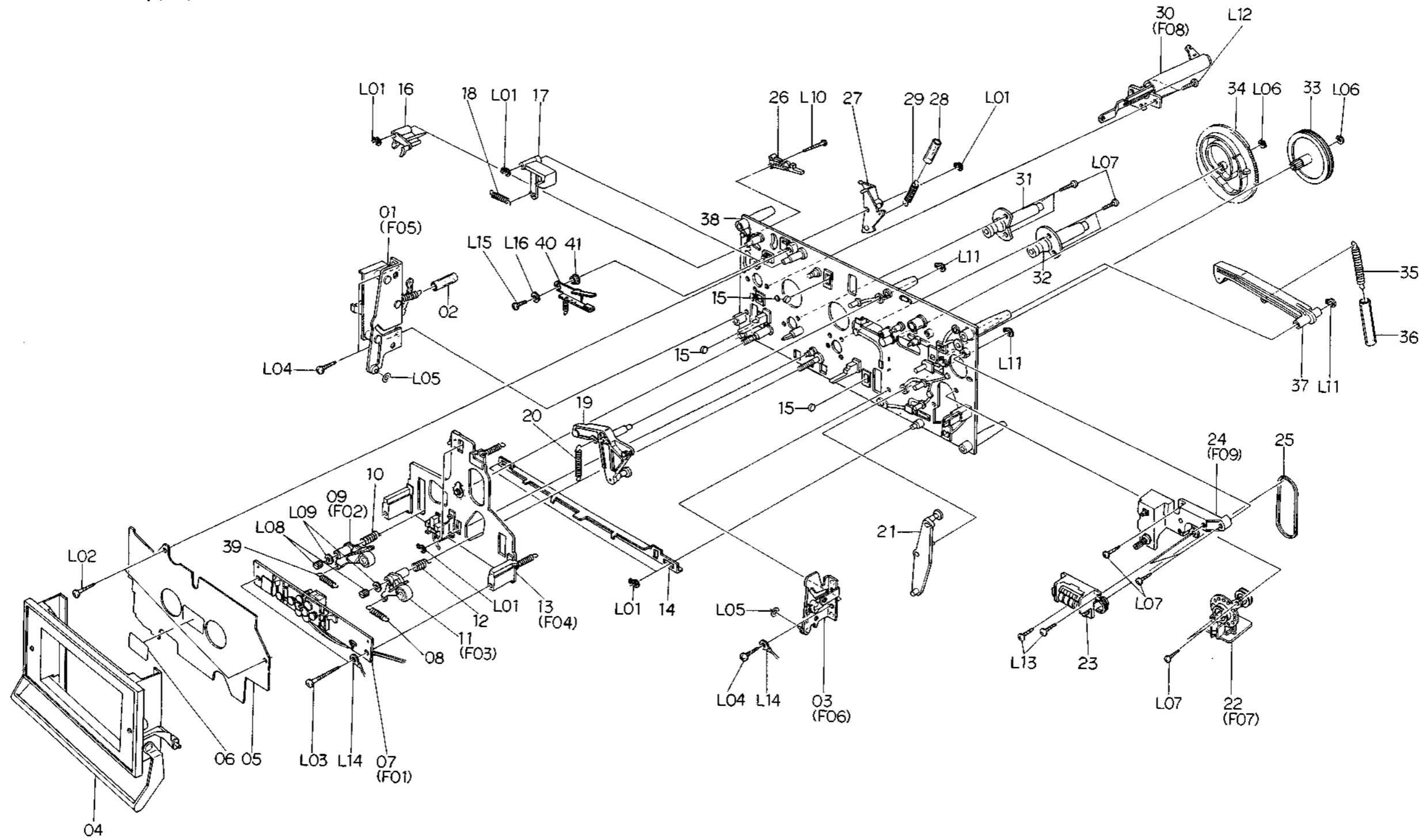

Fig. 8.9.1 Serial No.: A11606264 -

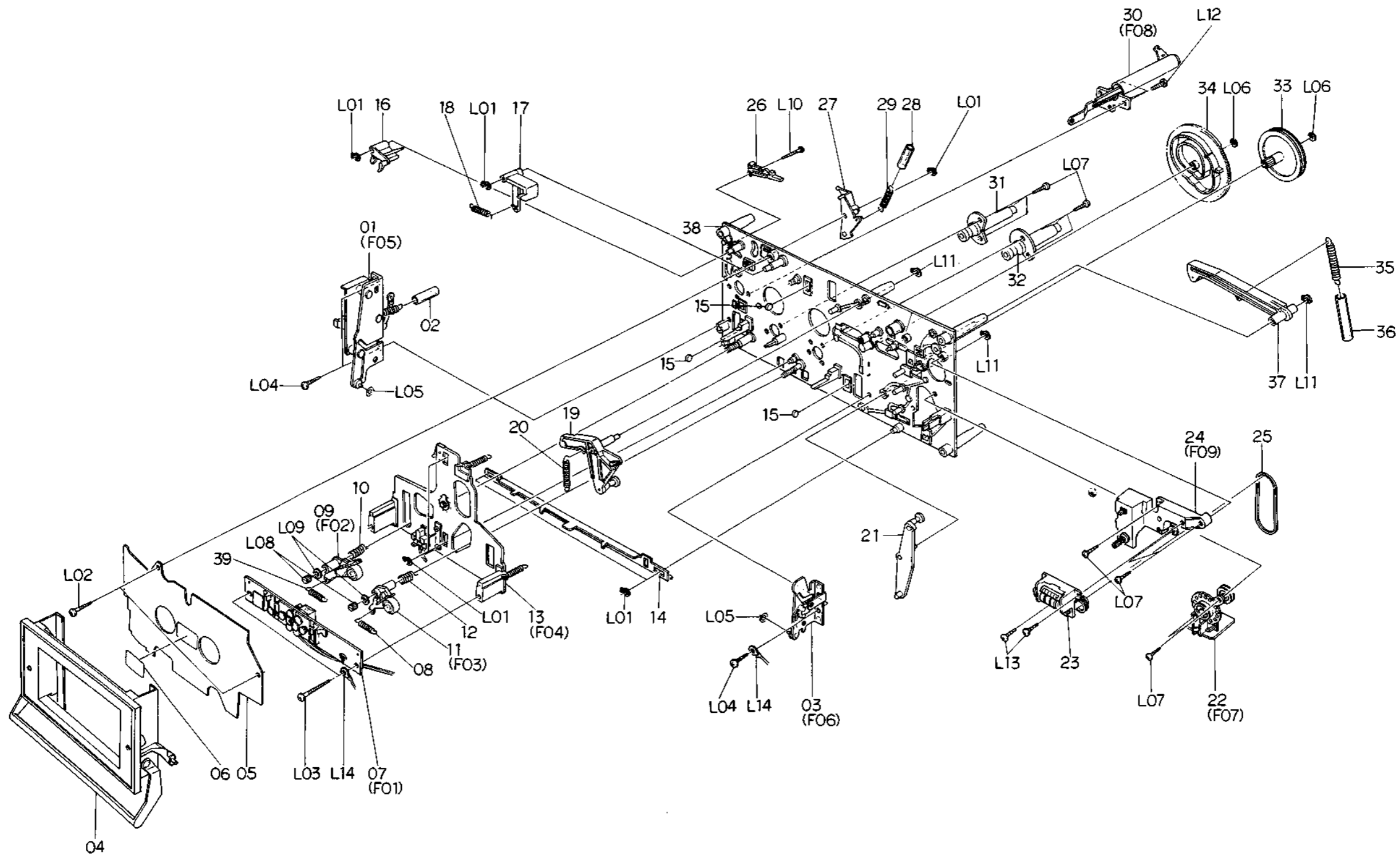

Fig. 8.9.2 Serial Nos.: A11604671 – A11606263

Schematic Ref. No.	Part No.	Description	Q'ty
C03	CA08181A	Main Mechanism Chassis Ass'y Serial Nos.: A11604671 - A11606263	1
01	CA08125A	Cassette Case Holder L Ass'y	1
02	0C08151A	Lid Arm Spring Tube	1
03	CA08022A	Cassette Case Holder R Ass'y	1
04	CA08163A	Cassette Case Ass'y	1
05	0C08019I	Cover Plate	1
06	0M03977A	Cassette Viewer Label	1
07	CA08160A	Head Mount Base Ass'y	1
08	0C08121A	Supply Pressure Roller Spring	1
09	CA08053B	Supply Pressure Roller Ass'y	1
10	0C08122B	Supply Pressure Roller Thrust Spring	1
11	CA08079B	Take-up Pressure Roller Ass'y	1
12	0C08183B	Take-up Pressure Roller Thrust Spring	1
13	CA08104A	Head Base Ass'y D	1
14	0C08182A	Pressure Roller Drive Bar B	1
15	0C08086B	Head Base Roller	3
16	0C08050B	Record Sensor	1
17	0C08051E	Cassette Hold Arm	1
18	0C08120A	Cassette Hold Arm Spring	1
19	CA08027A	Head Base Drive Arm Ass'y	1
20	0C08143C	Head Base Drive Arm Spring	1
21	CA08026A	Pressure Roller Drive Arm Ass'y	1
22	CA08099A	Auto Shut-off Ass'y	1
23	CA08098A	Counter Ass'y	1
24	CA08105A	Pitch Control Holder Ass'y	1
25	0C08224A	Counter Belt	1
26	0C08119A	Record Protector	1
27	0C08194C	Damper Lock Arm	1
28	0C08153A	Damper Lock Arm Spring Tube	1
29	0C08125A	Damper Lock Arm Spring	1
30	CA08030A	Pneumatic Damper Ass'y	1
31	CA08023A	Supply Capstan Flange Ass'y	1
32	CA08024A	Take-up Capstan Flange Ass'y	1
33	0C08186A	Cam Drive Gear	1
34	0C08029H	Control Cam	1
35	0C08152A	Counter-Load Arm Spring	1
36	0C08117A	Counter-Load Arm Spring Tube	1
37	CA08028A	Counter-Load Arm Ass'y	1
38	CA08072A	Main Chassis Ass'y	1
39	0C08250A	Supply Pressure Roller Spring B	1
L01	0E00837A	Stopper Ring 3mm	7
L02	0E00832A	BT Screw M3x14 Philips Pan Head	2
L03	0E00834A	BT Screw M3x30 Philips Pan Head	2
L04	0E00831A	BT Screw M3x10 Philips Pan Head	3
L05	0E00254A	Washer 3.1mm (Plastics)	2
L06	0E00222A	E-Ring 2mm	2
L07	0E00876A	BT Screw M2.6x8 Philips Pan Head	11
L08	0C08060B	Height Adjustment Nut	2
L09	0E00142A	Washer 2.6mm	2
L10	0E00879A	BT Screw M2.6x8 Philips Pan Head	1
L11	0E00838A	Stopper Ring 4mm	3
L12	0E00846A	BT Screw M3x8 Philips Pan Head	3
L13	0E00865A	BT Screw M3x10 Philips Binding Head	2
L14	0E00895A	Earth Lug 3mm	2

Schematic Ref. No.	Part No.	Description	Q'ty	Schematic Ref. No.	Part No.	Description	Q'ty
C03	CA08161A	Main Mechanism Chassis Ass'y Serial Nos.: A11603010 - A11604670	1	C03	CA08161A	Main Mechanism Chassis Ass'y Serial Nos.: A11601001 - A11603009	1
01	CA08125A	Cassette Case Holder L Ass'y	1	01	CA08125A	Cassette Case Holder L Ass'y	1
02	0C08151A	Lid Arm Spring Tube	1	02	0C08151A	Lid Arm Spring Tube	1
03	CA08022A	Cassette Case Holder R Ass'y	1	03	CA08022A	Cassette Case Holder R Ass'y	1
04	CA08163A	Cassette Case Ass'y	1	04	CA08163A	Cassette Case Ass'y	1
05	0C08019I	Cover Plate	1	05	0C08019I	Cover Plate	1
06	0M03977A	Cassette Viewer Label	1	06	0M03977A	Cassette Viewer Label	1
07	CA08160A	Head Mount Base Ass'y	1	07	CA08160A	Head Mount Base Ass'y	1
08	0C08121A	Supply Pressure Roller Spring	2	08	0C08121A	Supply Pressure Roller Spring	2
09	CA08053B	Supply Pressure Roller Ass'y	1	09	CA08053B	Supply Pressure Roller Ass'y	1
10	0C08122B	Supply Pressure Roller Thrust Spring	1	10	0C08122B	Supply Pressure Roller Thrust Spring	1
11	CA08079B	Take-up Pressure Roller Ass'y	1	11	CA08079A	Take-up Pressure Roller Ass'y	1
12	0C08183B	Take-up Pressure Roller Thrust Spring	1	12	0C08183B	Take-up Pressure Roller Thrust Spring	1
13	CA08104A	Head Base Ass'y D	1	13	CA08104A	Head Base Ass'y D	1
14	0C08182A	Pressure Roller Drive Bar B	1	14	0C08182A	Pressure Roller Drive Bar B	1
15	0C08086B	Head Base Roller	3	15	0C08086B	Head Base Roller	3
16	0C08050B	Record Sensor	1	16	0C08050B	Record Sensor	1
17	0C08051E	Cassette Hold Arm	1	17	0C08051E	Cassette Hold Arm	1
18	0C08120A	Cassette Hold Arm Spring	1	18	0C08120A	Cassette Hold Arm Spring	1
19	CA08027A	Head Base Drive Arm Ass'y	1	19	CA08027A	Head Base Drive Arm Ass'y	1
20	0C08143C	Head Base Drive Arm Spring	1	20	0C08143C	Head Base Drive Arm Spring	1
21	CA08026A	Pressure Roller Drive Arm Ass'y	1	21	CA08026A	Pressure Roller Drive Arm Ass'y	1
22	CA08099A	Auto Shut-off Ass'y	1	22	CA08099A	Auto Shut-off Ass'y	1
23	CA08098A	Counter Ass'y	1	23	CA08098A	Counter Ass'y	1
24	CA08105A	Pitch Control Holder Ass'y	1	24	CA08105A	Pitch Control Holder Ass'y	1
25	0C08224A	Counter Belt	1	25	0C08224A	Counter Belt	1
26	0C08119A	Record Protector	1	26	0C08119A	Record Protector	1
27	0C08194C	Damper Lock Arm	1	27	0C08194C	Damper Lock Arm	1
28	0C08153A	Damper Lock Arm Spring Tube	1	28	0C08153A	Damper Lock Arm Spring Tube	1
29	0C08125A	Damper Lock Arm Spring	1	29	0C08125A	Damper Lock Arm Spring	1
30	CA08030A	Pneumatic Damper Ass'y	1	30	CA08030A	Pneumatic Damper Ass'y	1
31	CA08023A	Supply Capstan Flange Ass'y	1	31	CA08023A	Supply Capstan Flange Ass'y	1
32	CA08024A	Take-up Capstan Flange Ass'y	1	32	CA08024A	Take-up Capstan Flange Ass'y	1
33	0C08186A	Cam Drive Gear	1	33	0C08186A	Cam Drive Gear	1
34	0C08029H	Control Cam	1	34	0C08029H	Control Cam	1
35	0C08152A	Counter-Load Arm Spring	1	35	0C08152A	Counter-Load Arm Spring	1
36	0C08117A	Counter-Load Arm Spring Tube	1	36	0C08117A	Counter-Load Arm Spring Tube	1
37	CA08028A	Counter-Load Arm Ass'y	1	37	CA08028A	Counter-Load Arm Ass'y	1
38	CA08072A	Main Chassis Ass'y	1	38	CA08072A	Main Chassis Ass'y	1
L01	0E00837A	Stopper Ring 3mm	7	L01	0E00837A	Stopper Ring 3mm	7
L02	0E00832A	BT Screw M3x14 Philips Pan Head	2	L02	0E00832A	BT Screw M3x14 Philips Pan Head	2
L03	0E00834A	BT Screw M3x30 Philips Pan Head	2	L03	0E00834A	BT Screw M3x30 Philips Pan Head	2
L04	0E00831A	BT Screw M3x10 Philips Pan Head	3	L04	0E00831A	BT Screw M3x10 Philips Pan Head	3
L05	0E00254A	Washer 3.1mm (Plastics)	2	L05	0E00254A	Washer 3.1mm (Plastics)	2
L06	0E00222A	E-Ring 2mm	2	L06	0E00222A	E-Ring 2mm	2
L07	0E00876A	BT Screw M2.6x8 Philips Pan Head	11	L07	0E00876A	BT Screw M2.6x8 Philips Pan Head	11
L08	0C08060B	Height Adjustment Nut	2	L08	0C08060B	Height Adjustment Nut	2
L09	0E00142A	Washer 2.6mm	2	L09	0E00142A	Washer 2.6mm	2
L10	0E00879A	BT Screw M2x15 Philips Pan Head	1	L10	0E00879A	BT Screw M2x15 Philips Pan Head	1
L11	0E00838A	Stopper Ring 4mm	3	L11	0E00838A	Stopper Ring 4mm	3
L12	0E00846A	BT Screw M3x8 Philips Pan Head	3	L12	0E00846A	BT Screw M3x8 Philips Pan Head	3
L13	0E00865A	BT Screw M3x10 Philips Binding Head	2	L13	0E00865A	BT Screw M3x10 Philips Binding Head	2
L14	0E00895A	Earth Lug 3mm	2	L14	0E00895A	Earth Lug 3mm	2

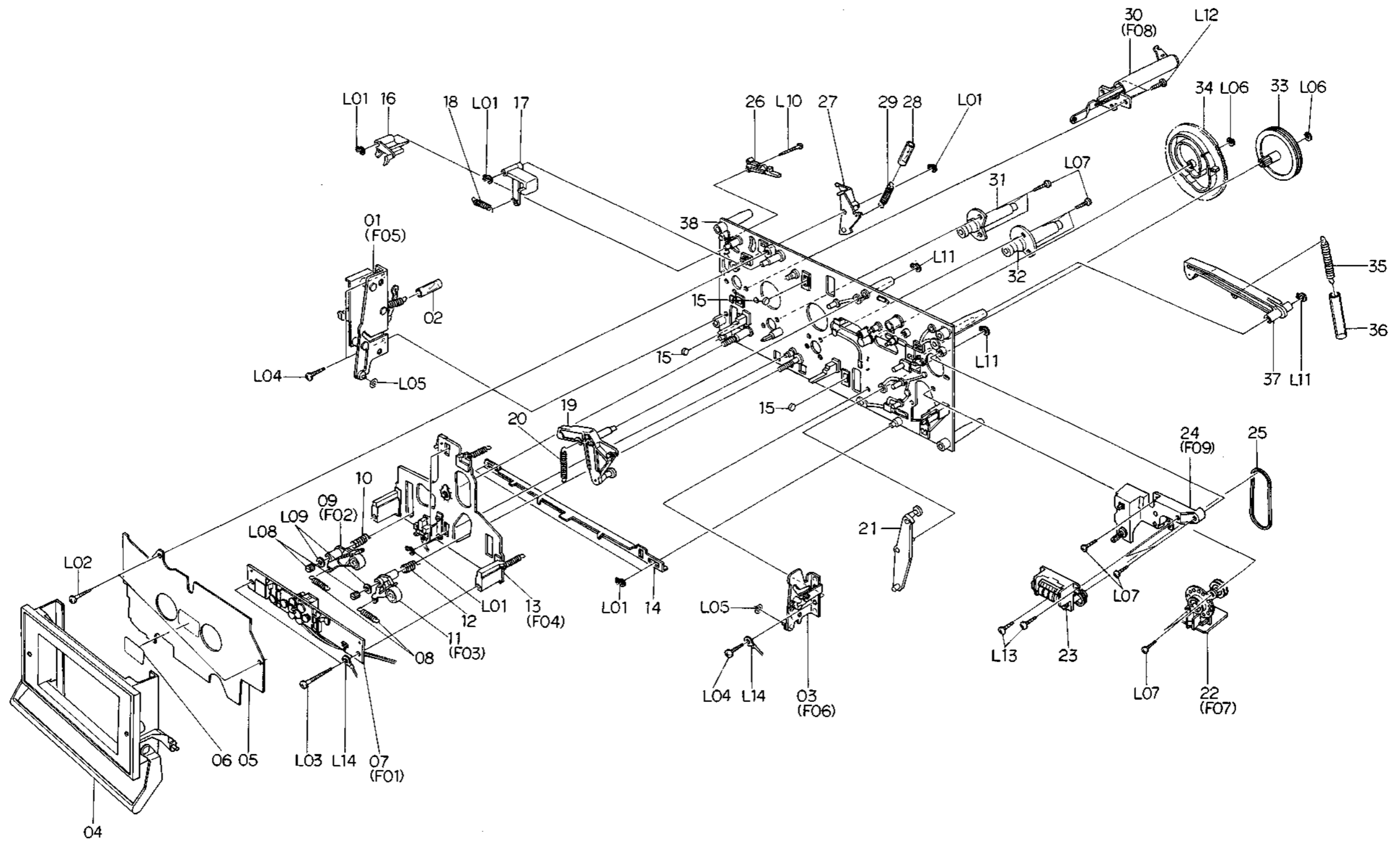

Fig. 8.9.3 Serial Nos.: A11601001 – A11604670

8.10. FL Indicator Ass'y (D01)

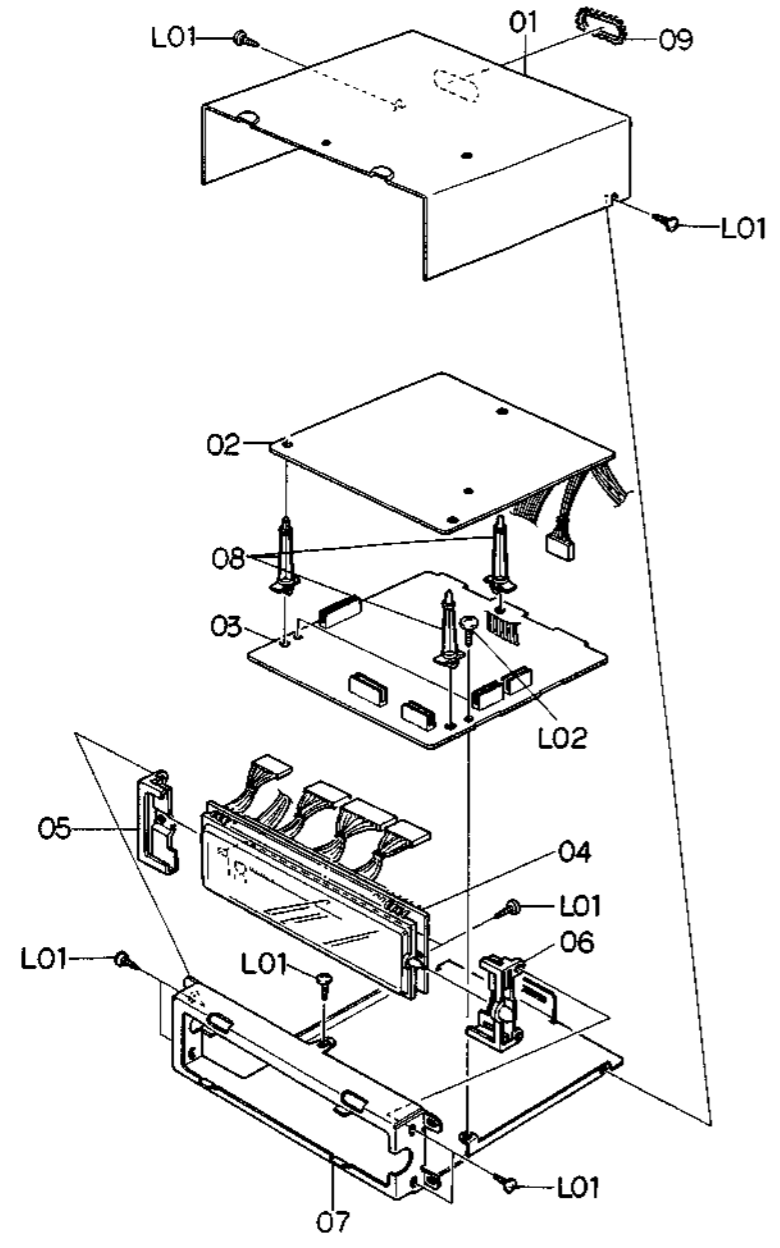

Fig. 8.10

8.11. Calibration Case Ass'y (D02)

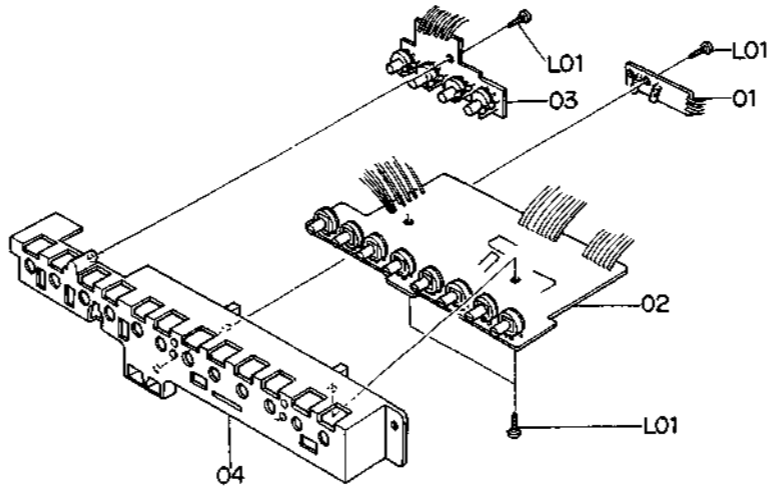

Fig. 8.11

8.12. Volume Holder Ass'y (D03)

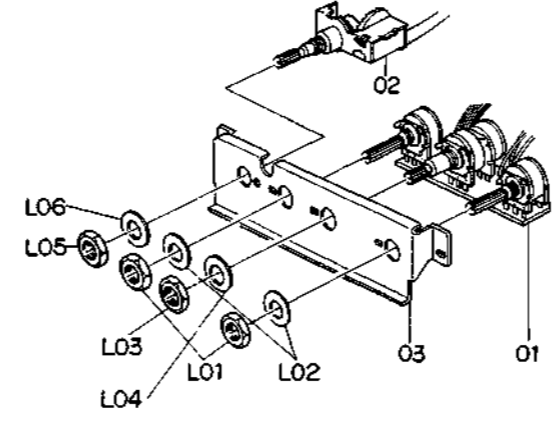

Fig. 8.12

8.13. Headphone Jack Ass'y (D04)

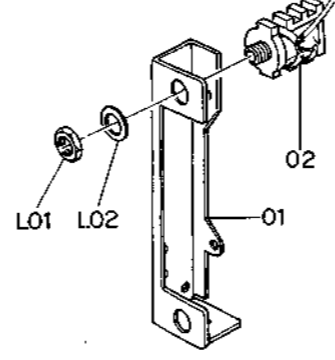

Fig. 8.13

8.14. Reflector Ass'y (D05)

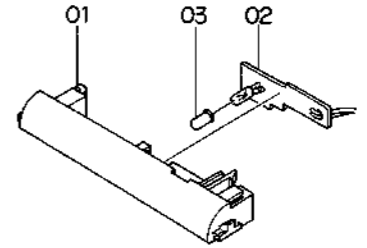

Fig. 8.14

8.15. Counter Lamp Ass'y (D06)

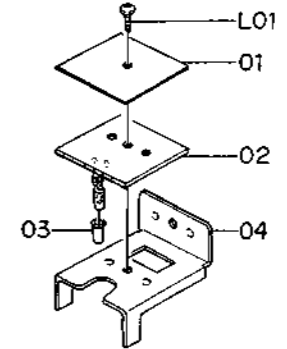

Fig. 8.15

8.16. Power Switch Holder Ass'y (D07)

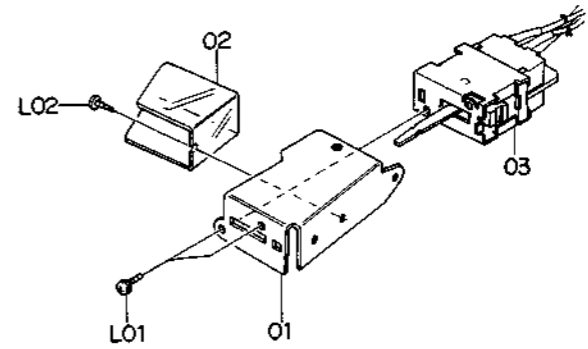

Fig. 8.16

Schematic Ref. No.	Part No.	Description	Q'ty	Schematic Ref. No.	Part No.	Description	Q'ty
D01	JA03587A	FL Indicator Ass'y Serial No.: A11601001 -	1	D07	JA03592A	Power Switch Holder Ass'y (U.S.A. & Canada)	1
01	0J04037A	Shield Cover	1		JA03595A	Power Switch Holder Ass'y (Japan)	1
02	BA04066A	Indicator P.C.B. C Ass'y	1		JA03594A	Power Switch Holder Ass'y (220V Class 2, UK, Australia & Others) Serial No.: A11601001 -	1
03	BA04065A	Indicator P.C.B. B Ass'y	1	01	0J04038A	Power Switch Holder	1
04	BA04061A	Indicator P.C.B. A Ass'y	1	02	0J04066A	Power Switch Insulator	1
05	0J04039A	FL Indicator Holder L	1	03	0B07280A	Power Switch (U.S.A. & Canada)	1
06	0J04040A	FL Indicator Holder R	1		0B07291A	Power Switch (Japan)	1
07	0J04036A	FL Indicator Hold Plate	1		0B07292A	Power Switch (220V Class 2, UK, Australia & Others)	1
08	0J04058A	P.C.B. Supporter	3	L01	0E00622A	Screw M3x5 Philips Pan Head (2A)	2
09	0J04063A	Free Bushing 69mm	1	L02	0E00873A	BT Screw M2.6x5 Philips Binding Head	1
L01	0E00859A	BT Screw M2.6x6 Philips Binding Head	9				
L02	0E00857A	BT Screw M3x6 Philips Binding Head	2				
D02	JA03675A	Calibration Case Ass'y Serial No.: A11601001 -	1				
01	BA04072A	Lamp P.C.B. A Ass'y	1				
02	BA04067A	Record Cal. P.C.B. A Ass'y	1				
03	BA04068A	Record Cal. P.C.B. B Ass'y	1				
04	0J04108A	Calibration Case	1				
L01	0E00792A	BT Screw M2.6x6 Philips Pan Head	4				
D03	JA03589A	Volume Holder Ass'y Serial No.: A11601001 -	1				
01	BA04069A	Volume P.C.B. Ass'y	1				
02	0B07317A	Remote Switch	1				
03	0J04028D	Volume Holder	1				
L01	-	Volume Nut	(2)				
L02	-	Volume Washer	(2)				
L03	-	Volume Nut	(1)				
L04	-	Volume Washer	(1)				
L05	-	Remote Switch Nut	(1)				
L06	-	Remote Switch Washer	(1)				
D04	JA03659A	Headphone Jack Ass'y Serial No.: A11601001 -	1				
01	0J04101A	Headphone Jack Holder	1				
02	0B08511A	Headphone Jack	1				
L01	-	Headphone Jack Nut	(1)				
L02	-	Headphone Jack Washer	(1)				
D05	JA03600A	Reflector Ass'y Serial No.: A11601001 -	1				
01	0H03754C	Reflector	1				
02	BA04063A	Lamp P.C.B. C Ass'y	1				
03	0J04107A	Filter Cap	1				
D06	JA03602A	Counter Lamp Ass'y Serial No.: A11601001 -	1				
01	0J04083A	Insulator	1				
02	BA04062A	Lamp P.C.B. B Ass'y	1				
03	0J04107A	Filter Cap	1				
04	0J04041A	Counter Lamp P.C.B. Holder	1				
L01	0E00859A	BT Screw M2.6x6 Philips Binding Head	1				

Schematic Ref. No.	Part No.	Description	Q'ty	Schematic Ref. No.	Part No.	Description	Q'ty
D08	HA03972A	Rear Panel Ass'y (U.S.A. & Canada)	1	L06	0E00593A	Screw M3x6 Philips Binding Head (Bronze)	2
	HA03973A	Rear Panel Ass'y (Japan)	1	L07	0E00756A	Screw M4x8 Philips Binding Head (Bronze)	2
	HA03977A	Rear Panel Ass'y (220V Class 2)	1		0J03644A	Chobert Rivet	2
	HA03976A	Rear Panel Ass'y (Australia)	1				
	HA03975A	Rear Panel Ass'y (UK)	1				
	HA03974A	Rear Panel Ass'y (Others) Serial No.: A11601001 -	1				
						* : Depends on the versions.	
01	0H03819A	Rear Panel	1	E01	CA08117B	Reel Motor Ass'y Serial No.: A11601001 -	1
02	BA04176A	Pin Jack P.C.B. Ass'y	1	01	0C08218A	Reel Motor	1
03	0B08355A	4P DIN Socket		02	0C08063F	Reel Motor Pulley	1
04	0B08584A	8P DIN Socket					
05	BA04095A	Fuse P.C.B. Ass'y (U.S.A. & Canada)	1	E02	CA08034A	Control Motor Ass'y Serial No.: A11601001 -	1
	BA04096A	Fuse P.C.B. Ass'y (Japan)	1	01	0C08137A	Control Motor	1
	BA04105B	Fuse P.C.B. Ass'y (220V Class 2)	1	02	0C08064A	Control Motor Pulley	1
	BA04098B	Fuse P.C.B. Ass'y (UK & Australia)	1	03	0B09292A	Ceramic Capacitor 0.1μF 50V Z	1
	BA04097B	Fuse P.C.B. Ass'y (Others)	1	04	0M03985A	Control Motor Label	1
06	0C01162B	Bolt Receptacle Plate	2	05	0M03988A	Motor Seal B	1
07	0B06618B	Power Transformer (U.S.A. & Canada)	1				
	0B06619A	Power Transformer (Japan)	1	E03	CA08148A	Azimuth Alignment Motor Ass'y Serial No.: A11601001 -	1
	0B06621A	Power Transformer (220V Class 2, UK & Australia)	1	01	CA08149A	Azimuth Motor Ass'y	1
	0B06620B	Power Transformer (Others)	1	02	0C08099B	Control Motor Belt	1
08	0J04016A	Transformer Plate	1	03	0C08229B	Drive Pulley	1
09	0B08037U	Cord Bushing C (U.S.A., Canada, Japan, 220V Class 2 & Others)	1	04	0C08230B	Drive Pulley Shaft	1
	0B08719A	Cord Bushing (Australia)	1	05	0C08231B	Drive Nut	1
	0B08351A	Cord Bushing 4K-4 (UK)	1	06	0C08232C	Drive Bar	1
10	0B08533A	Power Cord (U.S.A., Canada & Others)	1	07	0C08233G	Drive Unit Base	1
	0B08219B	Power Cord (Japan)	1	08	0M04126A	Azimuth Alignment Unit Seal	1
	0B08093A	Power Cord (220V Class 2)	1	L01	0E00226A	Screw M2.6x4 Philips Pan Head	2
	0B08666A	Power Cord (Australia)	1	L02	0E00837A	Stopper Ring 3mm	1
	0B08348A	Power Cord (UK)	1				
11	0A03154B	Cord Spacer	1	F01	CA08160A	Head Mount Base Ass'y Serial No.: A11601001 -	1
12	0J03663A	Switch Cover (U.S.A., Canada, Japan, 220V Class 2, Australia & UK)	1	01	0C08028C	Head Height Adjustment Gear	2
	0M03946A	Voltage Selector Lock Plate C (Others)	1	02	0C08027E	Head Height Adjustment Screw	4
*13	0B07092U	Voltage Selector (Others)	1	03	0C08026D	Azimuth Alignment Screw	2
14	0J04079A	Cushion B	3	04	0C08161B	Spring Stopper	2
15	0M03458B	Pass Label	1	05	0C08187B	Head Plate Spring	2
*16	0M04075A	Fuse Caution Label (U.S.A. & Canada)	1	06	0C08236A	Azimuth Alignment Wire Hold Plate	1
17	0M03794A	Voltage Label 100V (Japan)	1	07	CA08083C	Head Mount Base Sub Ass'y	1
	0M03796A	Voltage Label 220V (220V Class 2)	1	08	CA08102A	P-8L Playback Head Ass'y	1
	0M03797A	Voltage Label 240V (Australia & UK)	1	09	0C08235A	Azimuth Alignment Plate	1
	0M03955A	Voltage Label 120V/220-240V (Others)	1	10	CA08159A	R-8L Record Head Ass'y	1
	0M03844B	Power Cord Label (UK)	1	L01	0E00917A	BT Screw M2.6x5 Philips Pan Head	2
-	0F01071A	Free-up Belt	1	F02	CA08053B	Supply Pressure Roller Ass'y Serial No.: A11601001 -	1
-	0M04064A	Serial Number Plate	1	01	0C08164G	Pressure Roller	1
L01	0B08720A	Plastic Rivet	4	02	0C08189B	Supply Tape Guide	1
L02	0E00594A	Screw M3x8 Philips Binding Head (Bronze)	3	03	CA08061A	Supply Pressure Roller Arm Ass'y	1
*L03	0E00507A	Nut Hex, M3	3	L01	0E00042A	E-Ring 1.5mm	1
*L04	0E00581A	Washer 3mm (Spring)	3	L02	0C08024A	Washer 2mm	2
L05	0E00714A	Screw M2.6x6 Philips Binding Head (Bronze)	4	L03	0E00788A	BT Screw M2x8 Philips Pan Head	1

8.17. Rear Panel Ass'y (D08)

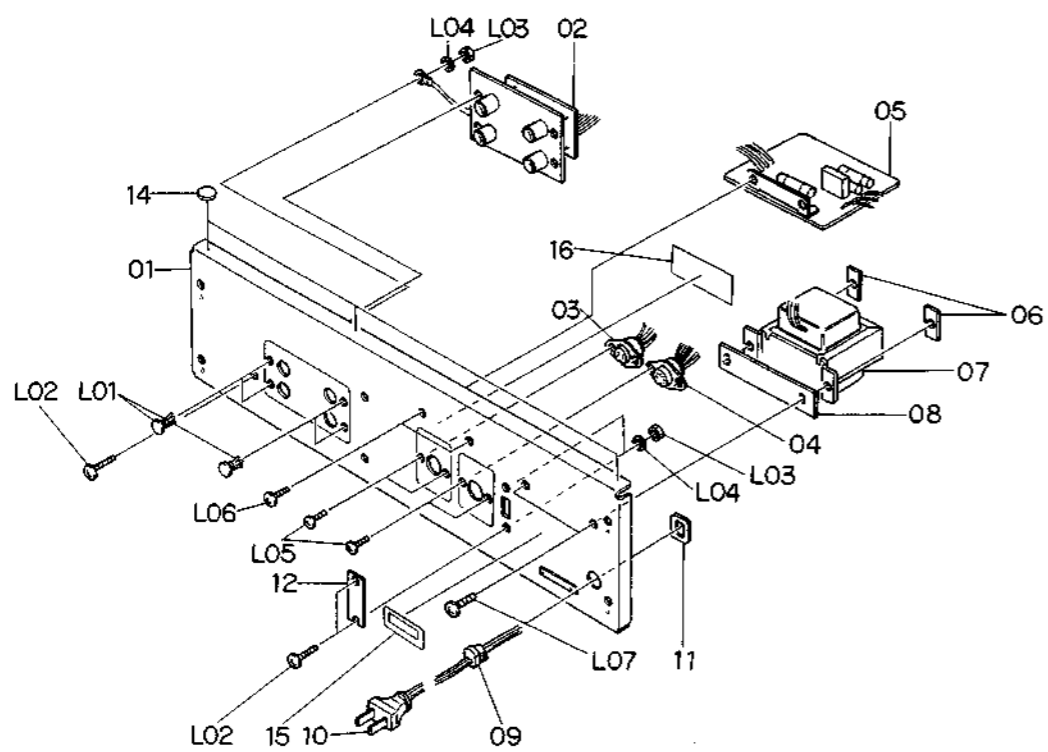
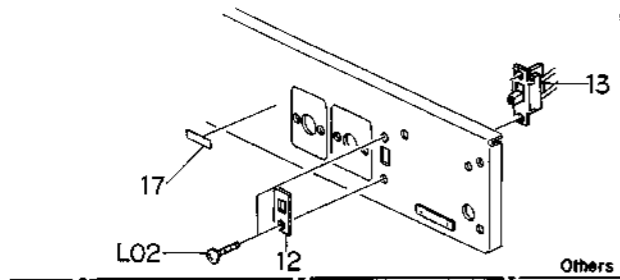

Fig. 8.17

8.18. Reel Motor Ass'y (E01)

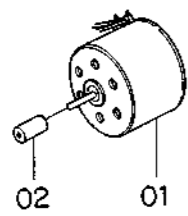

Fig. 8.18

8.19. Control Motor Ass'y (E02)

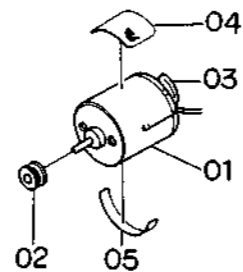

Fig. 8.19

8.20. Azimuth Alignment Motor Ass'y (E03)

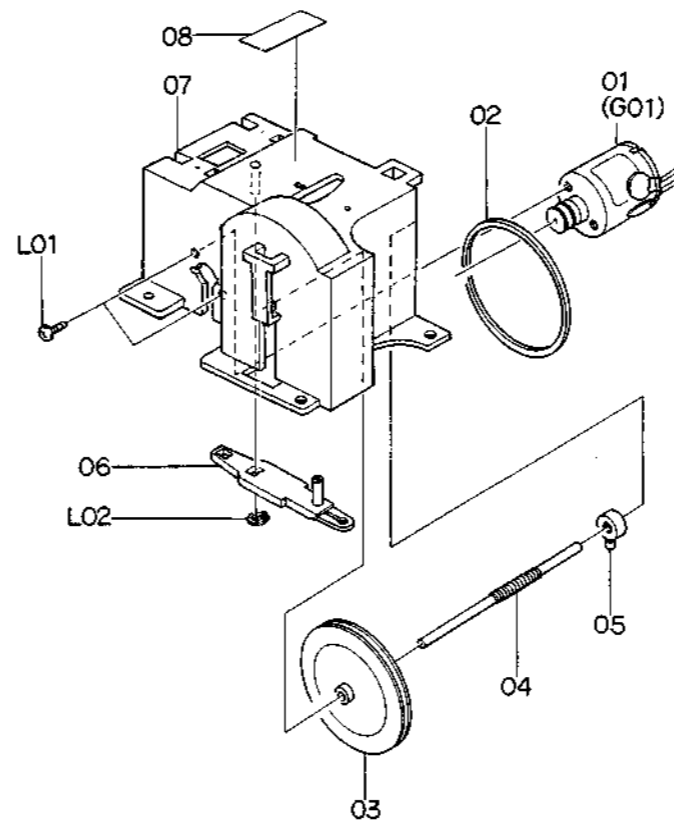

Fig. 8.20

8.22. Supply Pressure Roller Ass'y (F02)

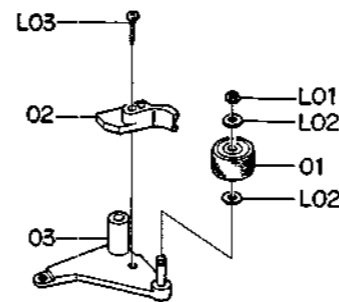

Fig. 8.22

8.21. Head Mount Base Ass'y (F01)

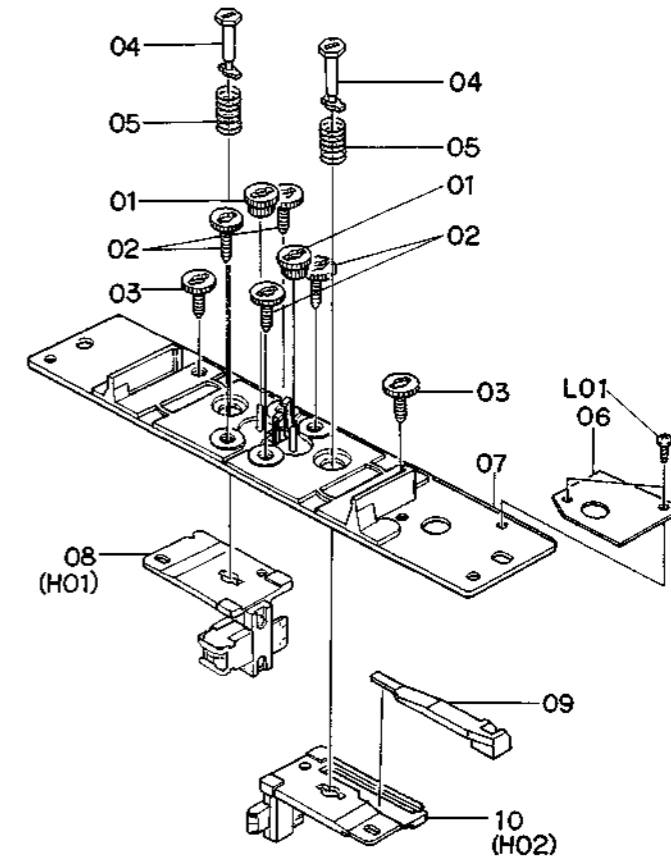

Fig. 8.21

8.23. Take-up Pressure Roller Ass'y (F03)

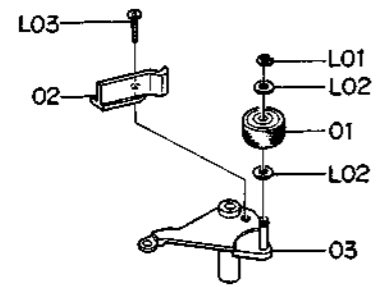

Fig. 8.23

8.24. Head Base Ass'y D (F04)

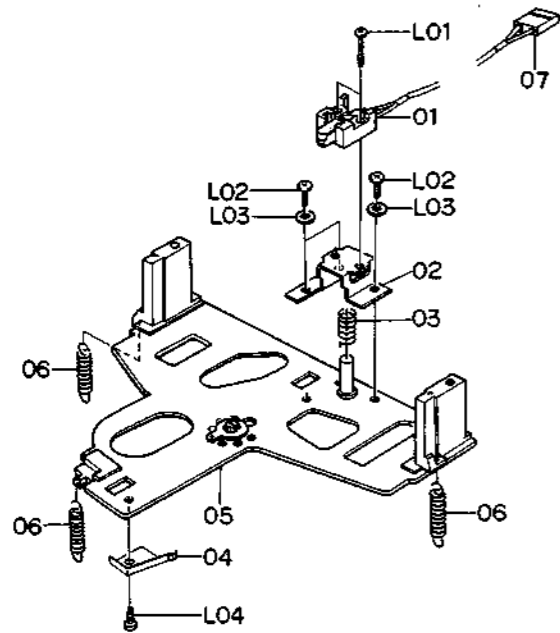

Fig. 8.24

8.25. Cassette Case Holder L Ass'y (F05)

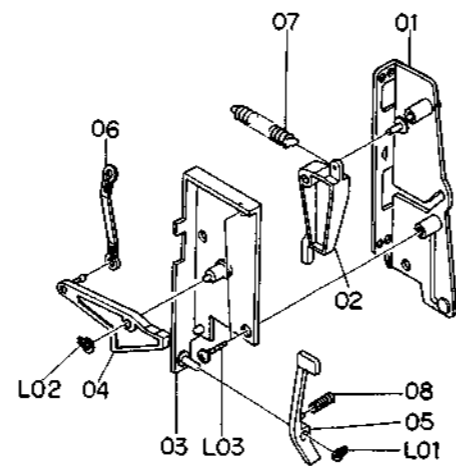

Fig. 8.25

8.26. Cassette Case Holder R Ass'y (F06)

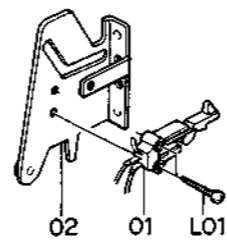

Fig. 8.26

8.27. Auto Shut-off Ass'y (F07)

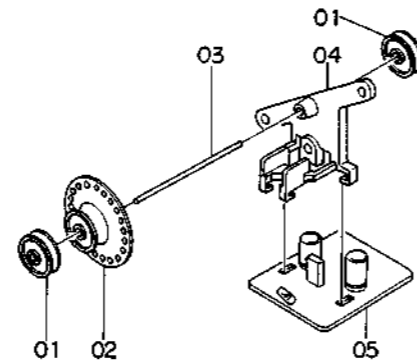

Fig. 8.27

8.28. Pneumatic Damper Ass'y (F08)

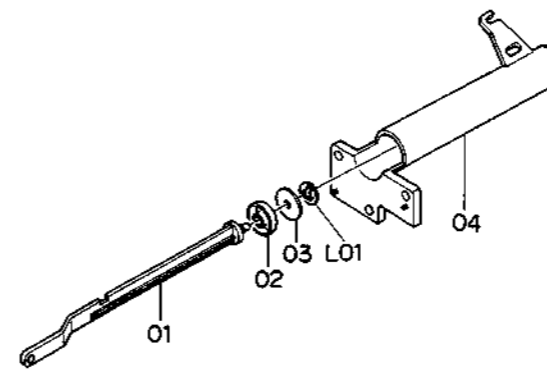

Fig. 8.28

8.29. Pitch Control Holder Ass'y (F09)

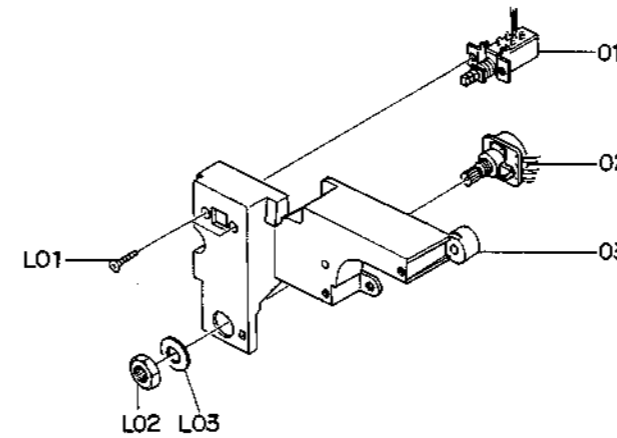

Fig. 8.29

8.30. Azimuth Motor Ass'y (G01)

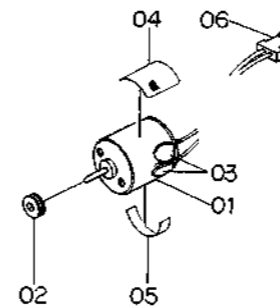

Fig. 8.30

8.31. P-8L Playback Head Ass'y (H01)

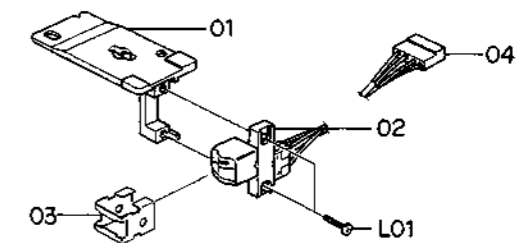

Fig. 8.31

8.32. R-8L Record Head Ass'y (H02)



Fig. 8.32

Schematic Ref. No.	Part No.	Description	Q'ty	Schematic Ref. No.	Part No.	Description	Q'ty
F03	CA08079B	Take-up Pressure Roller Ass'y Serial No.: A11603010 --	1	F07	CA08089A	Auto Shut-off Ass'y Serial No.: A11601001 --	1
01	0C08164G	Pressure Roller	1	01	0C08047A	Shut-off Pulley A	2
02	0C08181C	Take-up Tape Guide	1	02	0C08206B	Shut-off Pulley B	1
03	CA08024B	Take-up Pressure Roller Arm Ass'y	1	03	0C08210A	Shut-off Pulley Shaft	1
L01	0E00042A	E-Ring 1.5mm	1	04	0C08207B	Shut-off Pulley Holder	1
L02	0C08024A	Washer 2mm	2	05	BA04070A	Shut-off P.C.B. Ass'y	1
L03	0E00788A	BT Screw M2x8 Philips Pan Head	1	F08	CA08030A	Pneumatic Damper Ass'y Serial No.: A11601001 --	1
F03	CA08079A	Take-up Pressure Roller Ass'y Serial Nos.: A11601001 -- A11603009	1	01	0C08058C	Damper Piston	1
01	0C08164G	Pressure Roller	1	02	0C08102B	Damper Ring	1
02	0C08181B	Take-up Tape Guide	1	03	0C08010C	Damper Plate	1
03	CA08024B	Take-up Pressure Roller Arm Ass'y	1	04	0C08059D	Sylinder	1
L01	0E00042A	E-Ring 1.5mm	1	L01	0E00874A	Stopper Ring CS 2mm	1
L02	0C08024A	Washer 2mm	2	F09	CA08105A	Pitch Control Holder Ass'y Serial No.: A11601001 --	1
L03	0E00788A	BT Screw M2x8 Philips Pan Head	1	01	0B07283A	Memory Switch	1
F04	CA08104A	Head Base Ass'y D Serial No.: A11601001 --	1	02	0B07282A	Volume Control 20k Ω (B)	1
01	GA02083A	E-8LH Erase Head	1	03	0C08214D	Pitch Control Holder	1
02	0C08158D	EH Hold Plate	1	L01	0E00125A	Screw M2x6 Philips Countersunk	2
03	0C08166A	EH Hold Plate Spring	1	L02	--	Volume Nut	(1)
04	0C08174C	Cassette Hold Spring	1	L03	--	Volume Washer	(1)
05	CA08003P	Head Base Ass'y	1	G01	CA08149A	Azimuth Motor Ass'y Serial No.: A11601001 --	1
06	0C08175A	Head Base L Spring	3	01	0C08137A	Control Motor	1
07	0B08649E	2P-H Connector	1	02	0C08064A	Control Motor Pulley	1
L01	0E00889A	Screw M1.7x8 Philips Pan Head	2	03	0B09292A	Ceramic Capacitor 0.1 μ F 50V Z	2
L02	0E00909A	Screw M2x6 Philips Pan Head	3	04	0M03985A	Motor Label 730	1
L03	0E00117A	Washer 2mm	3	05	0M03988A	Motor Seal A	1
L04	0E00853A	BT Screw M2x3 Philips Pan Head	1	06	0B08708A	2P Connector	1
F05	CA08125A	Cassette Case Holder L Ass'y Serial No.: A11601001 --	1	H01	CA08102A	P-8L Playback Head Ass'y Serial No.: A11601001 --	1
01	CA08090F	Cassette Case Holder L Sub Ass'y	1	01	0C08160F	Head Plate	1
02	0C08073C	Lid Arm A	1	02	GA02085A	P-8LH Playback Head	1
03	0C08195G	Eject Arm Holder	1	03	0C08189D	Pad Lifter 54	1
04	0C08196B	Eject Arm A	1	04	0B08647D	4P-H Connector	1
05	0C08197C	Eject Arm B	1	L01	0E00886A	Screw M1.7x6.5 Philips Pan Head	2
06	0C08199B	Eject Arm Joint	1	H02	CA08159A	R-8L Record Head Ass'y Serial No.: A11601001 --	1
07	0C08114A	Lid Arm Spring	1	01	0C08234B	Head Plate	1
08	0C08211C	Eject Arm Spring	1	02	GA02084A	R-8LH Record Head	1
L01	0E00837A	Stopper Ring 3mm	1	03	0B08648C	4P-H Connector	1
L02	0E00838A	Stopper Ring 4mm	1	L01	0E00887A	Screw M1.7x4 Philips Pan Head	2
L03	0E00865A	BT Screw M3x10 Philips Binding Head	2	F06	CA08022A	Cassette Case Holder R Ass'y Serial No.: A11601001 --	1
01	0C08133A	Eject Sensor	1	01	0C08133A	Eject Sensor	1
02	CA08044A	Cassette Case Holder R Sub Ass'y	1	02	CA08044A	Cassette Case Holder R Sub Ass'y	1
L01	0E00840A	BT Screw M2x8 Philips Pan Head	2	L01	0E00840A	BT Screw M2x8 Philips Pan Head	2

9. OVERALL TIMING CHART

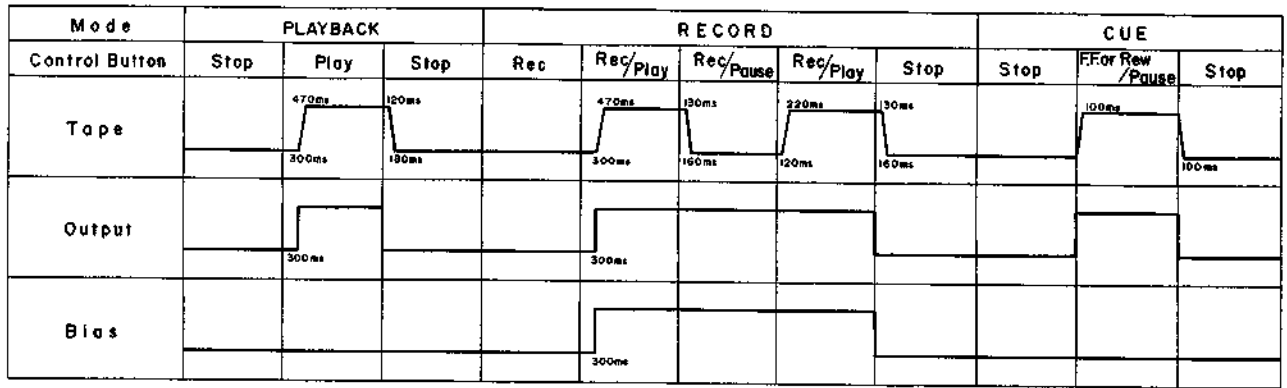

Fig. 9

10. EQ. AMP. FREQUENCY RESPONSE

10.1. Standard Speed (1-7/8 ips)

10.1.1. Playback Frequency Response

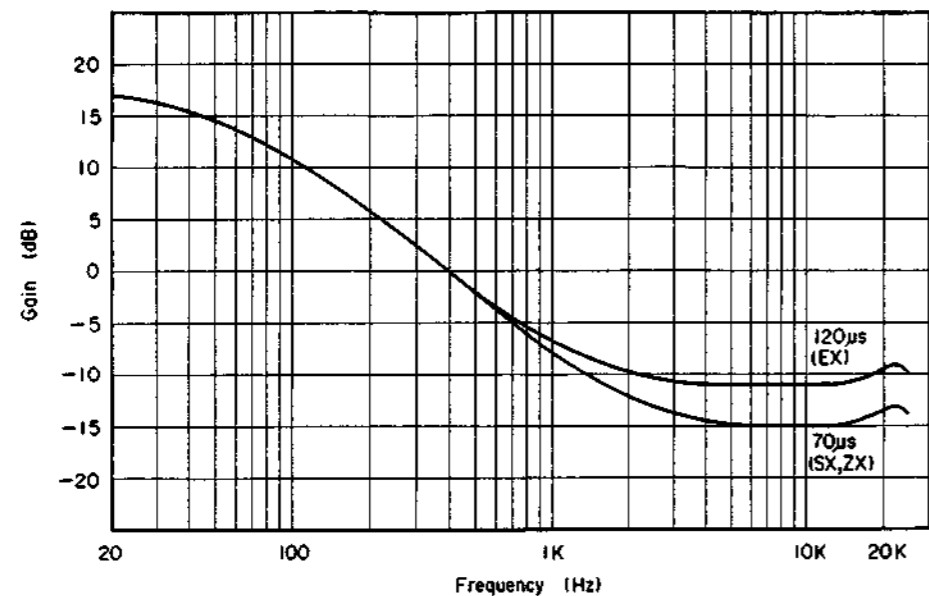

Fig. 10.1.1

10.2. Half-Speed (15/16 ips)

10.2.1. Playback Frequency Response

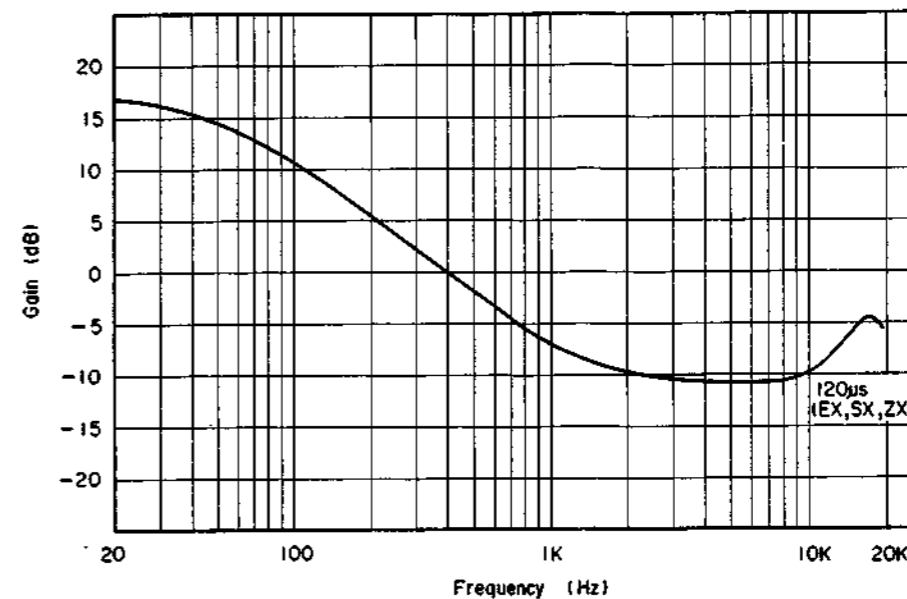

Fig. 10.2.1

10.1.2. Record Current Frequency Response

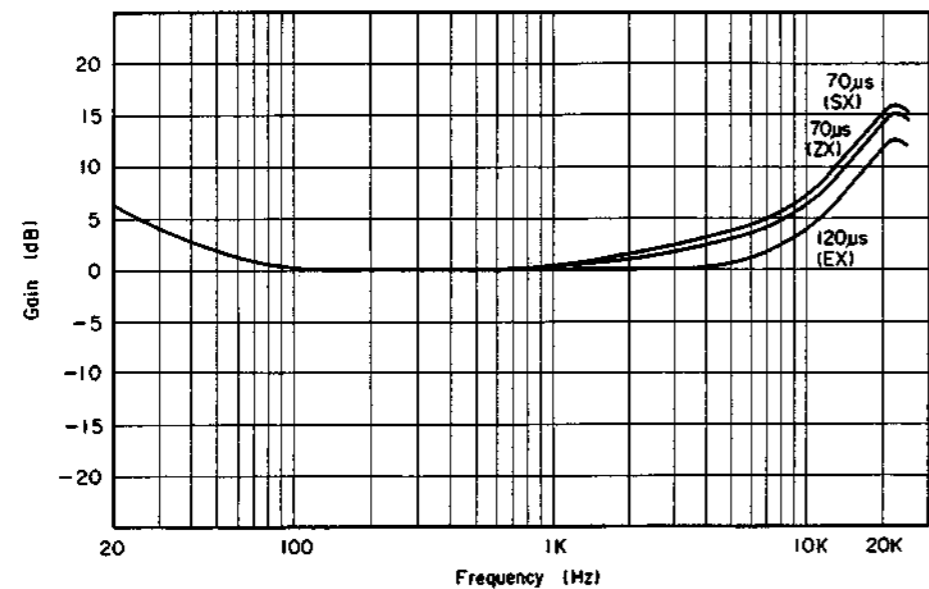

Fig. 10.1.2

10.2.2. Record Current Frequency Response

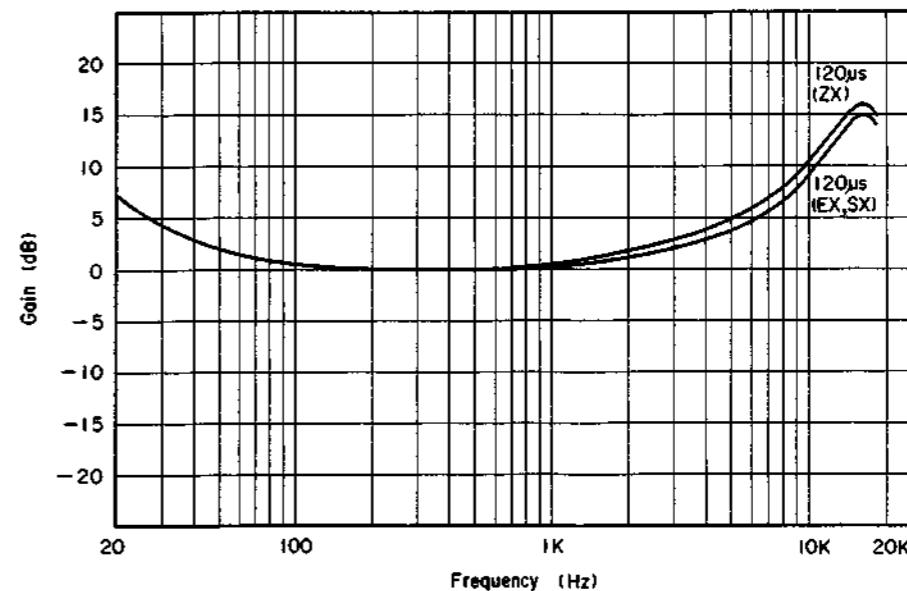

Fig. 10.2.2

11. BLOCK DIAGRAMS

11.1. Amplifier

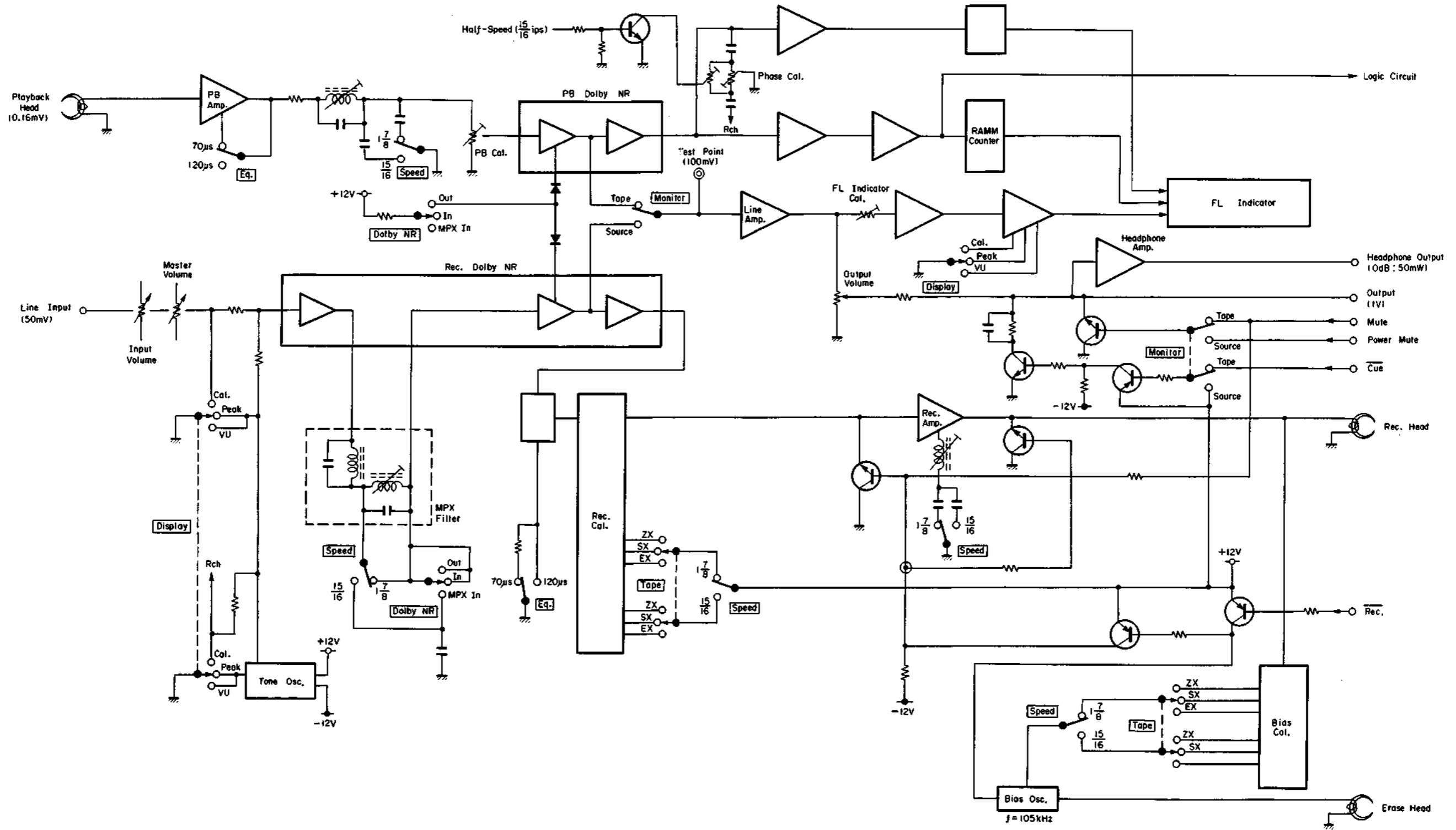

Fig. 11.1

11.2. Mechanism Control

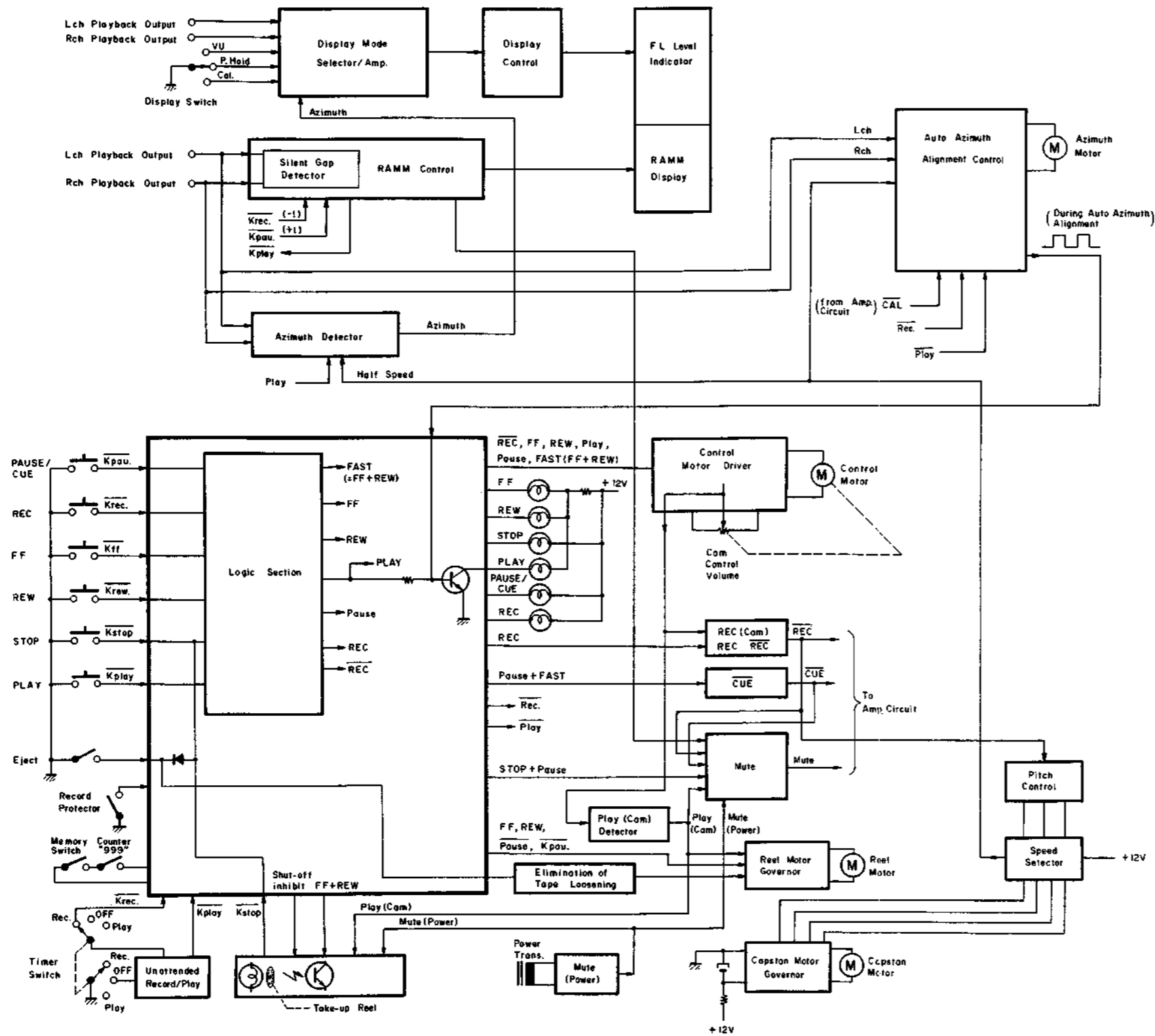
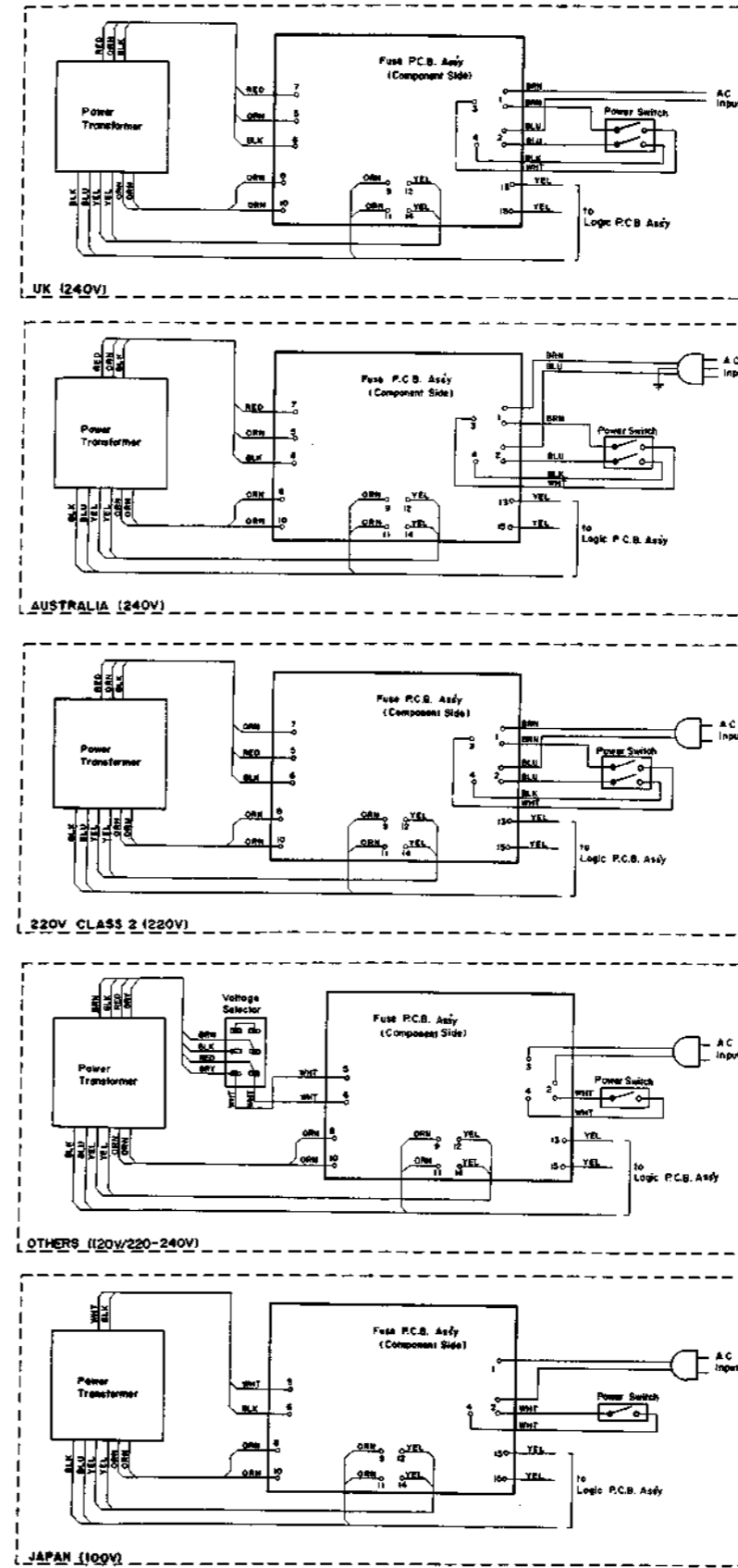

Fig. 11.2

12. WIRING DIAGRAM



Note: Table of wire colors
 BLK – Black
 BLU – Blue
 GRN – Green
 RED – Red
 WHT – White
 ORN – Orange
 GRY – Gray
 BRN – Brown
 YEL – Yellow
 VIO – Violet

Fig. 12.1

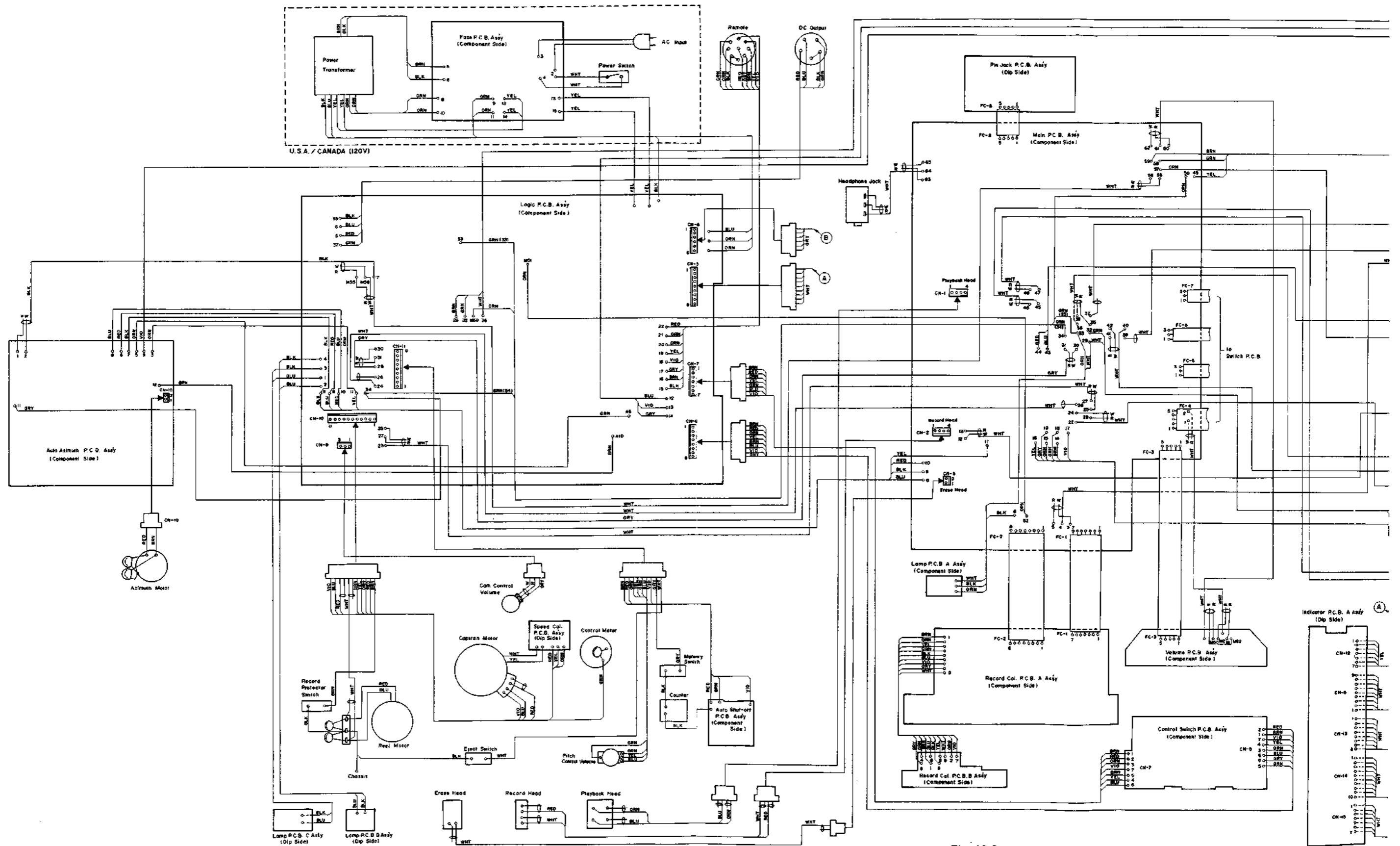

Fig. 12.2

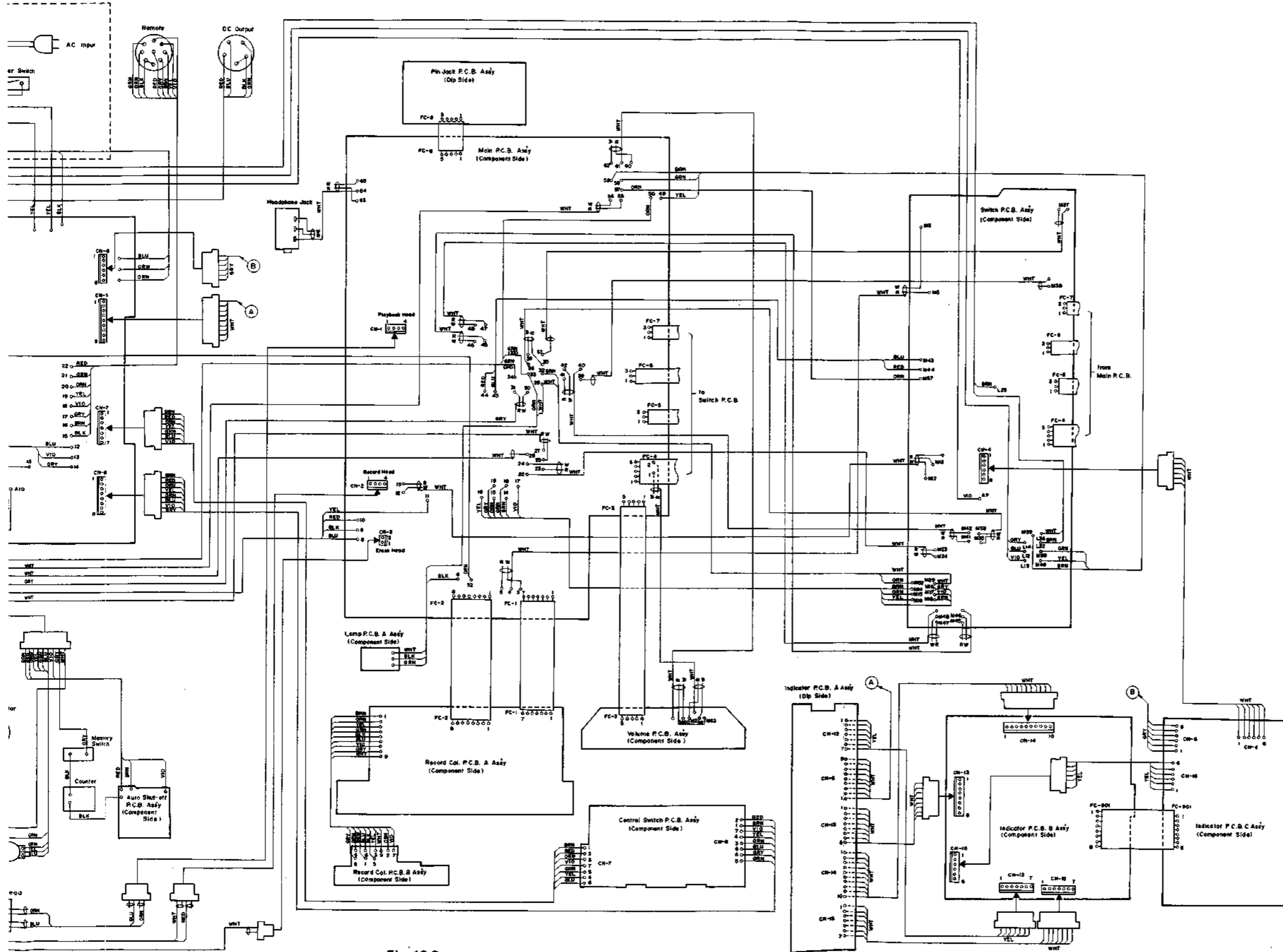

Fig. 12.2

13. SCHEMATIC DIAGRAMS

13.1. Amplifier

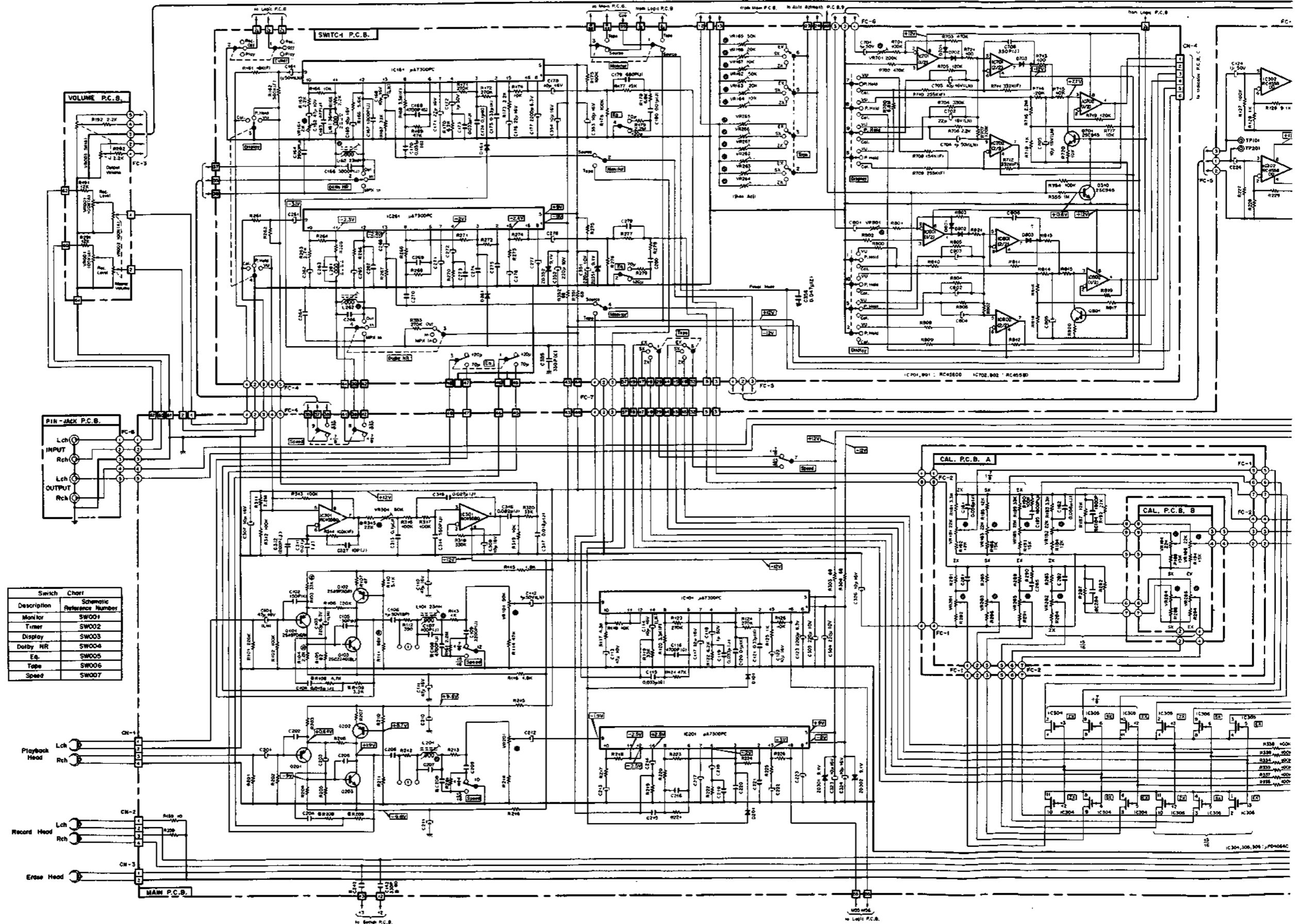

Fig. 13.1

- Notes: 1. Diode is 1S553, 1S953, or 1S1555 unless otherwise specified.
 2. Resistor and capacitor marked with * show typical value.

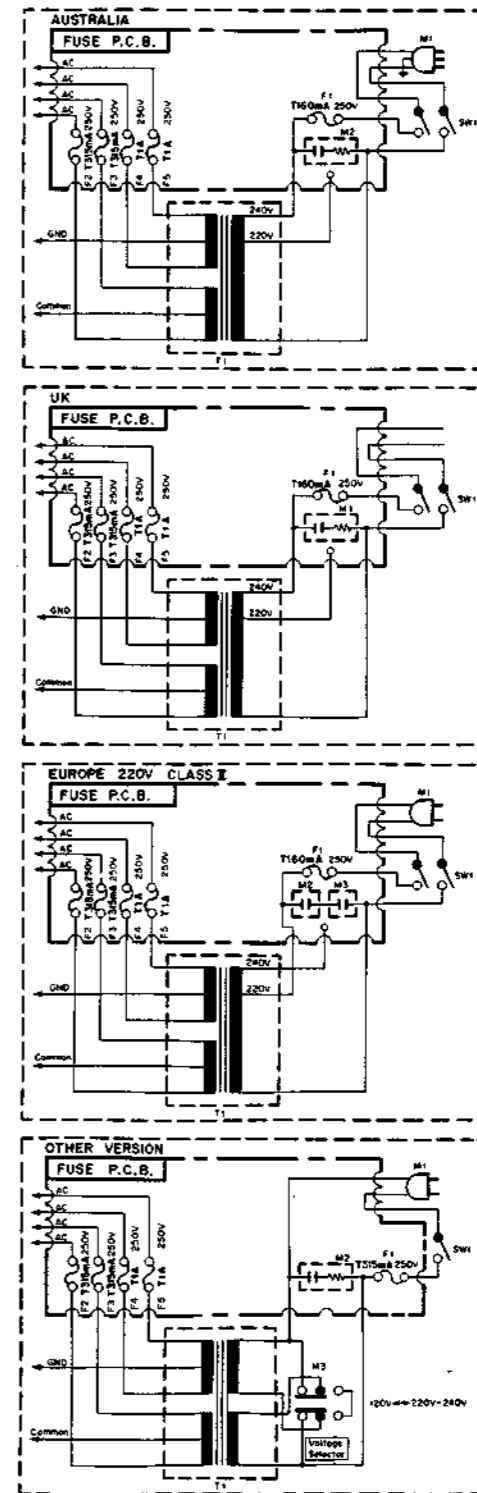
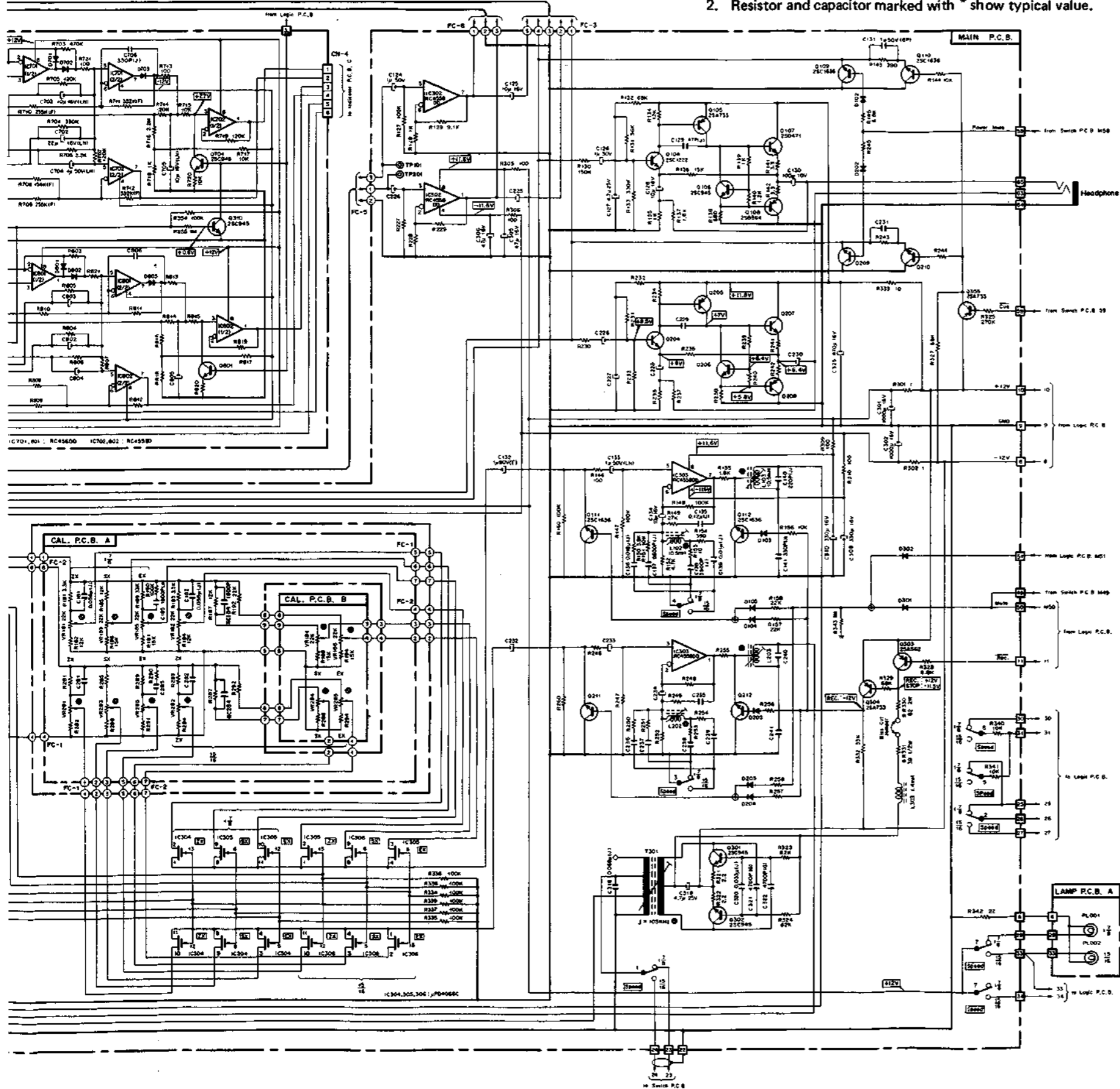

Fig. 13.1

13.2. Mechanism Control

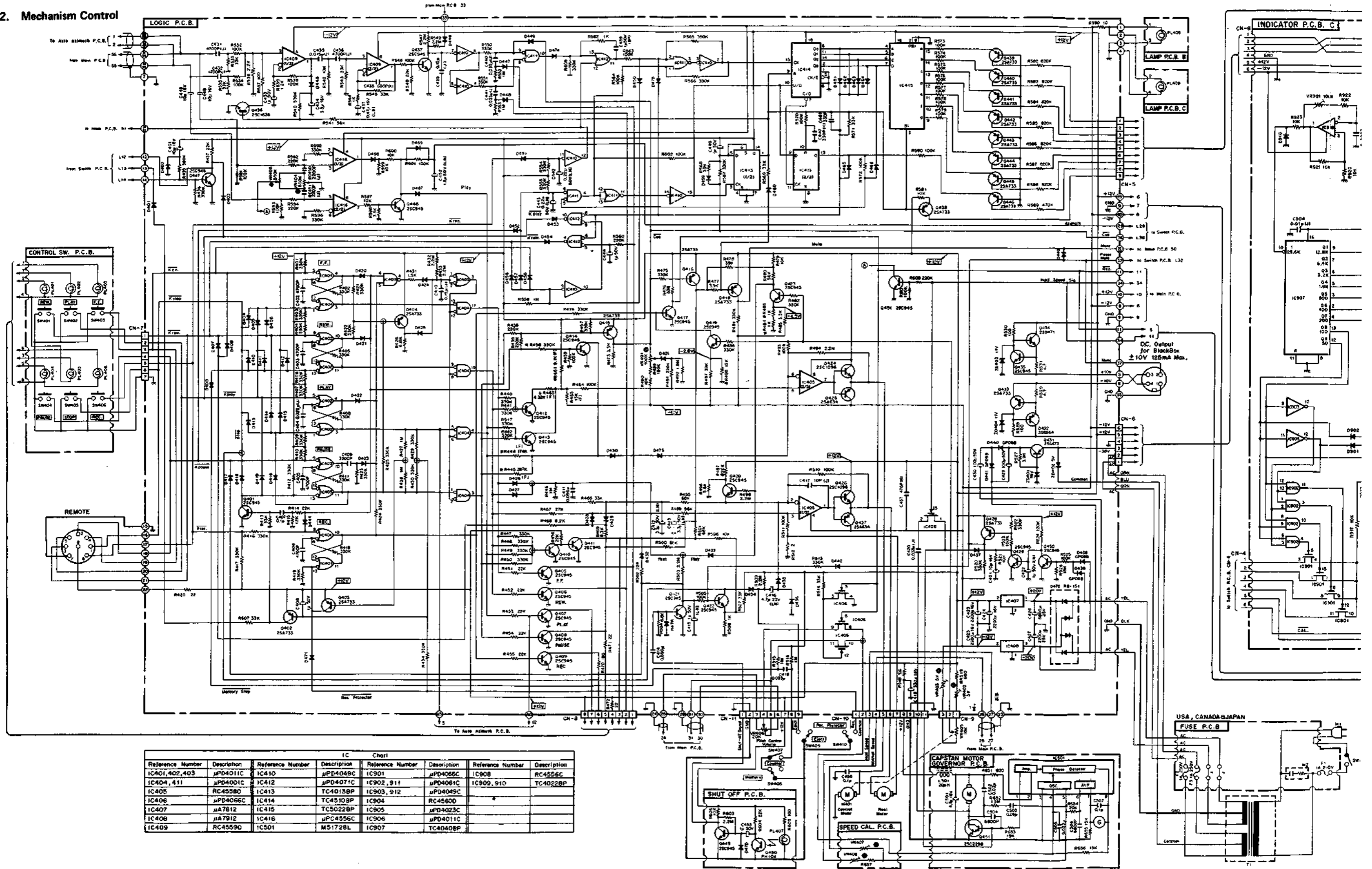

Fig. 13.2

- Notes: 1. Diode is 1S553, 1S953, or 1S1555 unless otherwise specified.
 2. Resistor and capacitor marked with * show typical value.

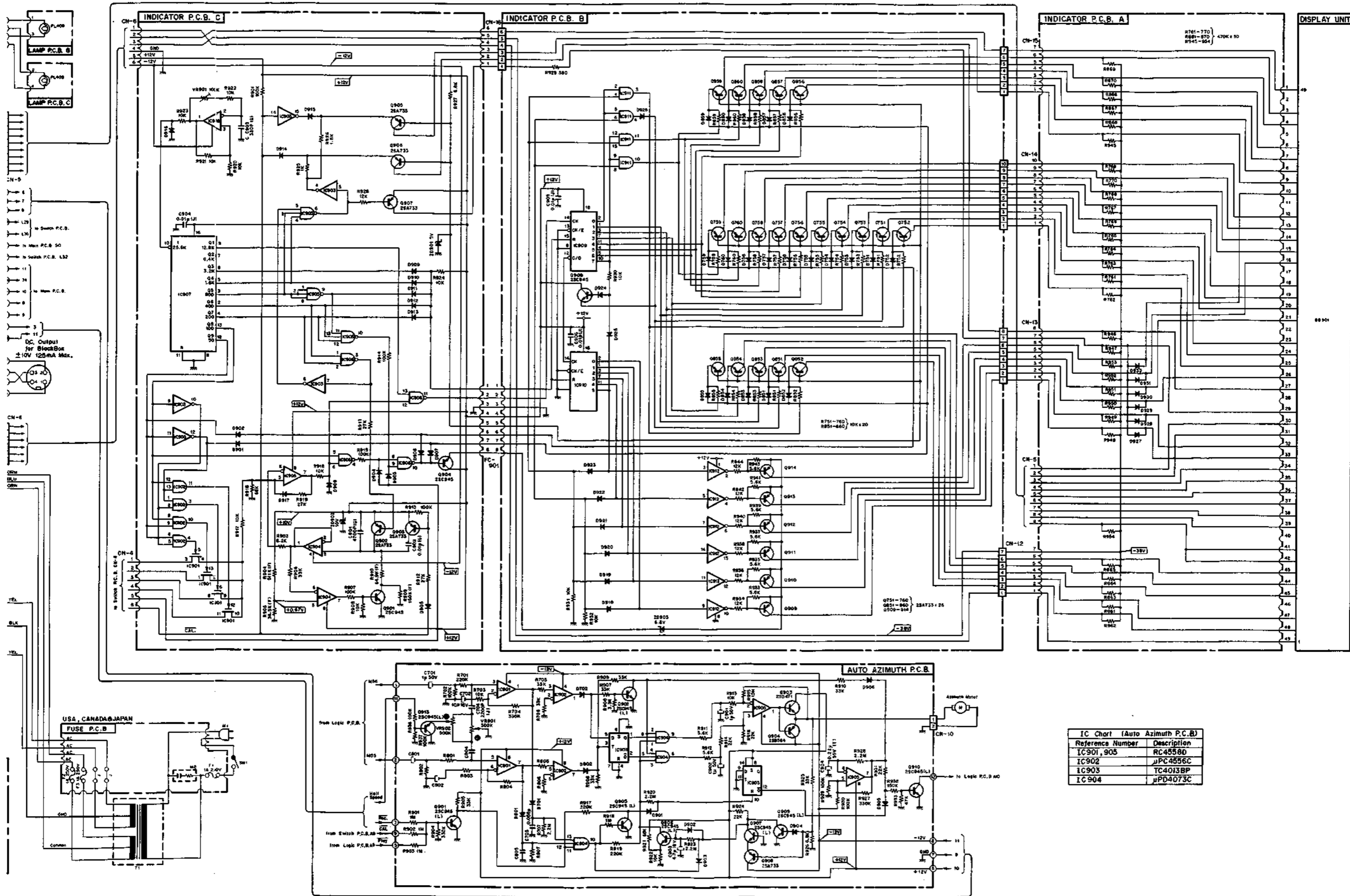

Fig. 13.2

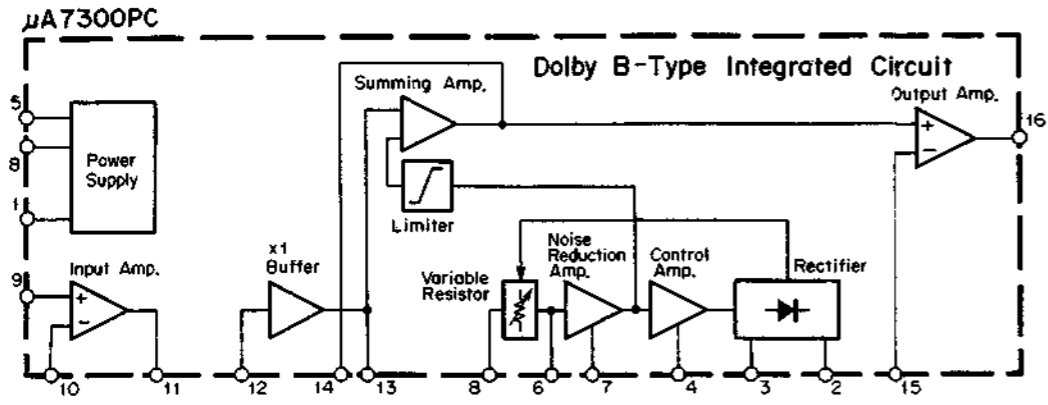

Fig. 13.3 Dolby NR IC $\mu A7300PC$

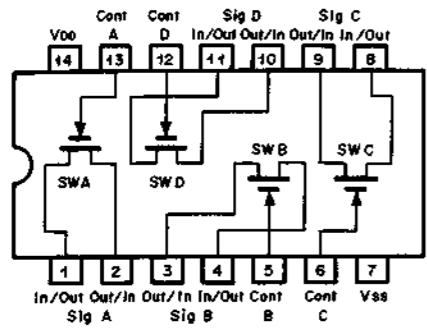

Fig. 13.4 Bilateral Switch C-MOS IC $\mu PD4066C$

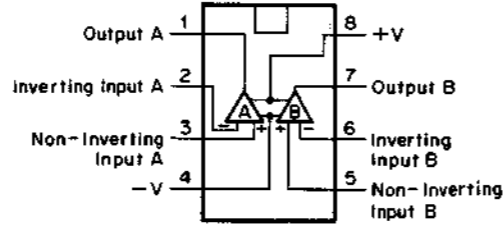

Fig. 13.5 Operational Amp. IC

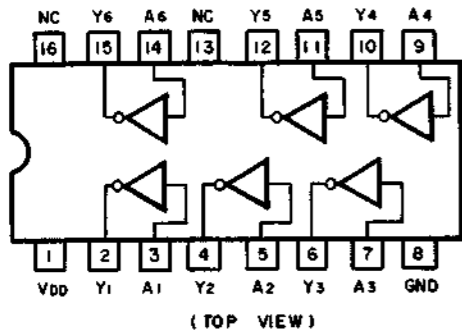

Fig. 13.6 Inverter C-MOS IC $\mu PD4049C$

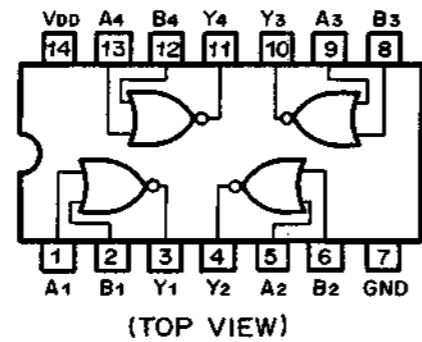

Fig. 13.7 NOR Gate C-MOS IC $\mu PD4001C$

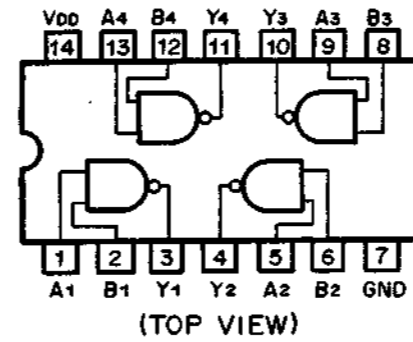

Fig. 13.8 NAND Gate C-MOS IC $\mu PD4011C$

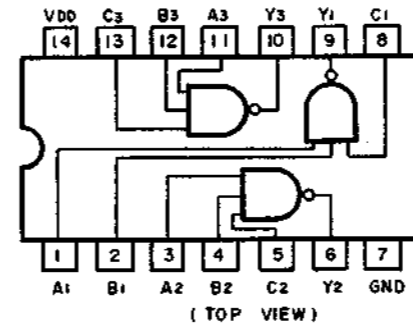

Fig. 13.9 NAND Gate C-MOS IC $\mu PD4023C$

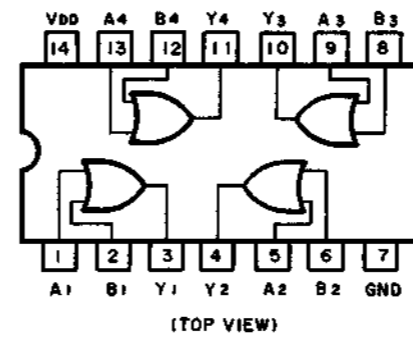

Fig. 13.10 OR Gate C-MOS IC $\mu PD4071C$

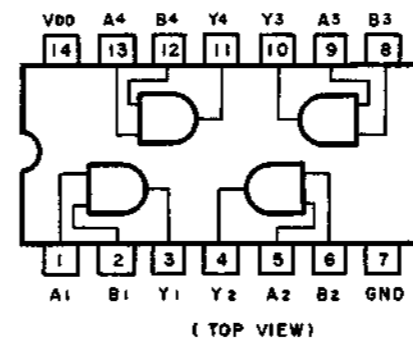

Fig. 13.11 AND Gate C-MOS IC $\mu PD4081C$

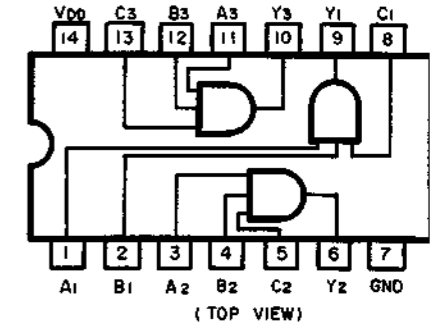

Fig. 13.12 AND Gate C-MOS IC $\mu PD4073$

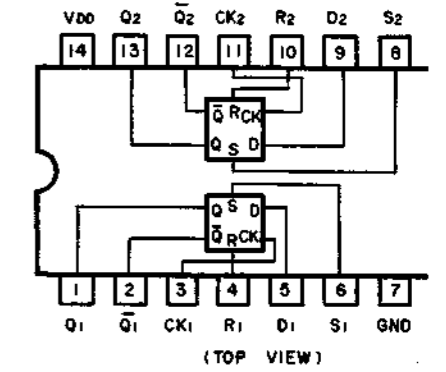

Fig. 13.13 D-Type Flip-Flop C-MOS IC

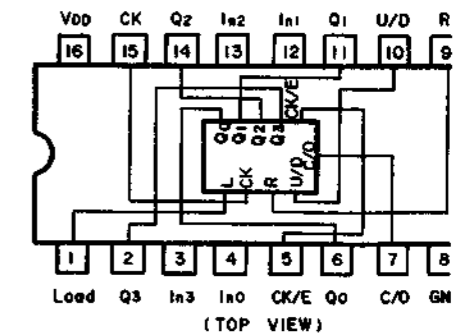

Fig. 13.14 BCD Up/Down Counter C-MOS IC

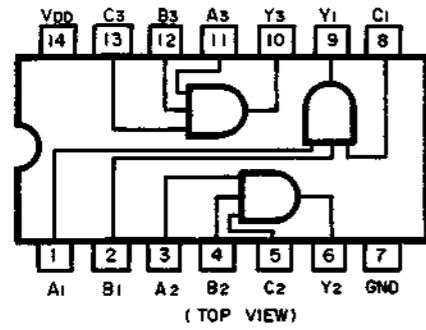

Fig. 13.12 AND Gate C-MOS IC μ PD4073C

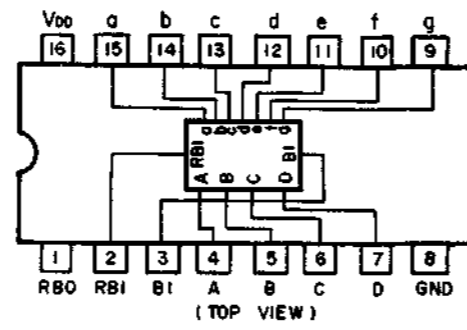

Fig. 13.15 BCD to 7-Segment Decoder/Driver C-MOS IC TC5022BP

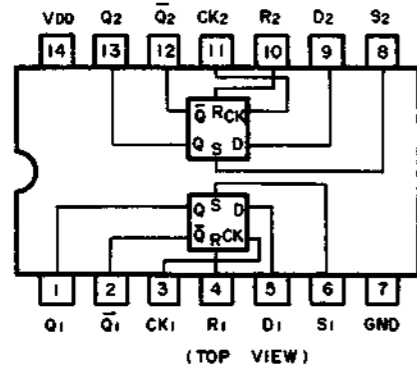

Fig. 13.13 D-Type Flip-Flop C-MOS IC TC4013BP

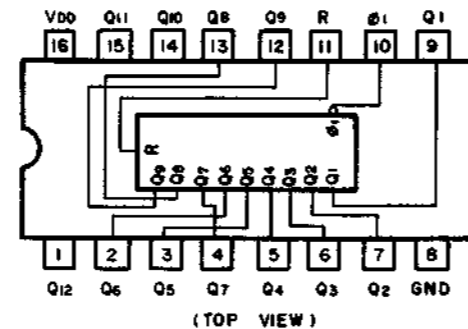

Fig. 13.16 12-Stage Binary Counter C-MOS IC TC4040BP

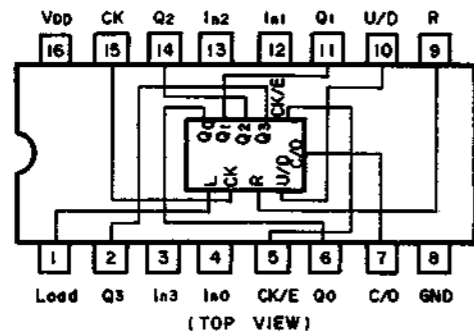

Fig. 13.14 BCD Up/Down Counter C-MOS IC TC4510BP

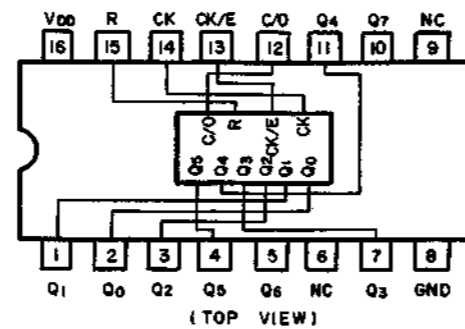

Fig. 13.17 Octal Counter/Driver C-MOS IC TC4022BP

14. SPECIFICATIONS

Standard Speed (1-7/8 ips)

Frequency Response	10-22,000 Hz \pm 3 dB (-20 dB rec. level)
Signal-to-Noise Ratio	Better than 66 dB (IHF-A WTD RMS, ref. 400 Hz, 3% THD, w/Dolby NR, ZX tape, 70 μ sec EQ)
Total Harmonic Distortion	Less than 0.8% at 400 Hz, 0 dB w/ZX tape Less than 1.0% at 400 Hz, 0 dB w/SX, EXII tapes
Wow-and-Flutter	Less than 0.08% WTD peak, 0.04% WTD RMS
Erasure	Better than 60 dB below saturation level at 1 kHz

Half-Speed (15/16 ips)

Frequency Response	10-15,000 Hz \pm 3 dB (-20 dB rec. level, ZX tape)
Signal-to-Noise Ratio	Better than 60 dB (IHF-A WTD RMS, ref. 400 Hz, 3% THD, w/Dolby NR, ZX tape, 120 μ sec EQ)
Total Harmonic Distortion	Less than 1.5% at 400 Hz, 0 dB w/ZX tape
Wow-and-Flutter	Less than 0.14% WTD peak, 0.08% WTD RMS
Erasure	Better than 60 dB below saturation level at 1 kHz

General

Separation	Better than 37 dB at 1 kHz, 0 dB
Crosstalk	Better than 60 dB at 1 kHz, 0 dB
Bias Frequency	105 kHz
Input	50 mV, 50 k ohms
Output	1 V (400 Hz, 0 dB, output control at max.) 2.2 k ohms
Headphone Output	45 mW (at 400 Hz, 0 dB, 8 ohms)
DC Output Jack	\pm 10 V DC, 125 mA max.
Power Source	100, 120, 120/220-240, 220 or 240 V AC; 50/60 Hz (according to country of sale)
Power Consumption	30 W max.
Dimensions	482(W) x 143(H) x 340(D) millimeters 19(W) x 5-5/8(H) x 13-3/8(D) inches
Approximate Weight	9 kg. 19 lb. 13 oz.

- Specifications and appearance design are subject to change for further improvement without notice.
- Dolby NR under license from Dolby Laboratories.
- The word "DOLBY" and the Double-D-Symbol are trademarks of Dolby Laboratories.