

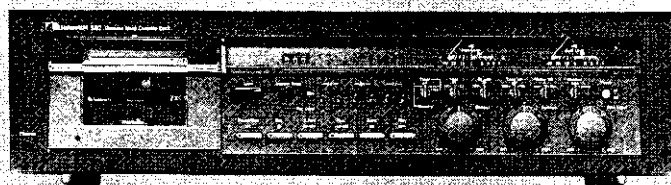

# Service Manual

# Nakamichi 582

Discrete Head Cassette Deck



## CONTENTS

1. General	3
2. Principle of Operation	5
2. 1. Mechanisms	5
2.1.1. 3-Head Configuration	5
(1) Playback Head	5
(2) Record Head	6
(3) Erase Head	6
(4) Headblock	6
2.1.2. Double Capstan Tape Drive	7
2.1.3. Mechanism Control Cam Operation	8
2. 2. Amp. Circuits	9
2.2.1. Playback Eq. Amp. Circuit	9
2.2.2. Record Amp. Circuit	11
2.2.3. Bias Osc. Circuit	11
2.2.4. Test Tone Circuit	12
2. 3. Mechanism Control Circuits	13
2.3.1. Logic Control	13
(1) C-MOS IC	13
(2) Logic Control and Other Circuits	15
2.3.2. Shut-off Sensor and Detector	20
2.3.3. Control Motor Drive Circuit	21
2.3.4. Capstan Motor Governor	22
2.3.5. Reel Motor Governor	23
2. 4. Remote Control Unit RM-580 (Optional)	24
2.4.1. Introduction	24
2.4.2. Transmitter	24
2.4.3. Receiver	25
3. Removal Procedures	27
3. 1. Acrylic Cassette Compartment Cover	27
3. 2. Top Cover Ass'y	27
3. 3. Bottom Cover Ass'y	27
3. 4. Front Panel Ass'y	27
3. 5. Mechanism Ass'y	27
3. 6. Main P.C.B. Ass'y	28
3. 7. Logic P.C.B. Ass'y	28
3. 8. Power Switch	28
3. 9. Volume P.C.B. Ass'y	28
3. 10. Control Button Ass'y	28
3. 11. Record Cal. P.C.B. Ass'y	28
3. 12. Meter Ass'y	29
3. 13. Lamp P.C.B. Ass'y	29
3. 14. Aluminum Mirror	29
3. 15. Rear Panel Ass'y	29
3. 16. Power Transformer	29
3. 17. Cassette Case Ass'y	29
3. 18. Cover Plate	30
3. 19. Tape Counter Ass'y	30
3. 20. Capstan Motor Ass'y and Flywheel Ass'y	31
3. 21. Sub Mechanism Chassis Ass'y	31
3. 22. Control Motor Ass'y	31
3. 23. Reel Motor Ass'y	31
3. 24. Cam Control Volume	31
3. 25. Reel Hub Ass'y	31
3. 26. Idler Ass'y	31
3. 27. Cam Drive Gear and Control Cam	31
3. 28. Head Mount Base Ass'y	31

3. 29.	Supply Pressure Roller Ass'y . . . . .	32
3. 30.	Erase Head . . . . .	32
3. 31.	Take-up Pressure Roller Ass'y . . . . .	32
3. 32.	Playback Head Ass'y . . . . .	32
3. 33.	Record Head Ass'y . . . . .	32
<b>4.</b>	<b>Measurement Instruments . . . . .</b>	<b>33</b>
<b>5.</b>	<b>Mechanical Adjustments . . . . .</b>	<b>34</b>
5. 1.	Mechanism Control Cam Adjustment . . . . .	34
5. 2.	Tape Speed Adjustment . . . . .	35
5. 3.	Record Head and Playback Head Tilt Adjustment . . . . .	35
5. 4.	Head Base Stroke Adjustment in Play and Cue Modes . . . . .	37
5. 5.	Tape Guides Adjustment and Erase Head Stroke Adjustment . . . . .	38
5. 6.	Erase Head Height and Tilt Adjustment . . . . .	39
5. 7.	Record Head and Playback Head Height Adjustment and Azimuth Alignment . . . . .	40
5. 8.	Record Head Stroke Adjustment . . . . .	41
5. 9.	Tape Travelling . . . . .	42
5. 10.	Flywheel Holder Adjustment . . . . .	42
5. 11.	Eject Wire Adjustment . . . . .	42
5. 12.	Control Button Stroke Adjustment . . . . .	42
5. 13.	Lubrication . . . . .	42
<b>6.</b>	<b>Parts Location for Electrical Adjustment . . . . .</b>	<b>43</b>
<b>7.</b>	<b>Electrical Adjustments and Measurements . . . . .</b>	<b>44</b>
7. 1.	Adjustments and Measurements Instructions . . . . .	44
7. 2.	Frequency Response Adjustment . . . . .	47
7.2.1.	Playback Frequency Response Adjustment . . . . .	47
7.2.2.	Record Current Frequency Response Adjustment . . . . .	48
7. 3.	Dolby NR Circuit Check . . . . .	48
<b>8.</b>	<b>Mounting Diagrams and Parts List . . . . .</b>	<b>49</b>
8. 1.	Main P.C.B. Ass'y . . . . .	49
8. 2.	Logic P.C.B. Ass'y . . . . .	51
8. 3.	Lamp P.C.B. Ass'y . . . . .	55
8. 4.	Control Switch P.C.B. Ass'y . . . . .	57
8. 5.	Volume P.C.B. Ass'y . . . . .	57
8. 6.	DIN-Pin P.C.B. Ass'y . . . . .	57
8. 7.	Shut-off P.C.B. Ass'y . . . . .	57
8. 8.	Record Cal. P.C.B. Ass'y . . . . .	57
<b>9.</b>	<b>Mechanism Ass'y and Parts List . . . . .</b>	<b>58</b>
9. 1.	Synthesis . . . . .	58
9. 2.	Synthesis Mechanism 582 (A01) . . . . .	60
9. 3.	Front Panel Ass'y 582 (B01) . . . . .	60
9. 4.	Headphone Jack Ass'y (B02) . . . . .	60
9. 5.	Mechanism Ass'y 582 (B03) . . . . .	61
9. 6.	Chassis Ass'y 582 (B04) . . . . .	61
9. 7.	Lamp House Cover Ass'y (C01) . . . . .	64
9. 8.	Flywheel Holder Ass'y (D01) . . . . .	64
9. 9.	Sub Mechanism Chassis Ass'y (D02) . . . . .	64
9. 10.	Main Mechanism Chassis Ass'y (D03) . . . . .	65
9. 11.	Rear Panel Ass'y (E01) . . . . .	67
9. 12.	Reel Motor Ass'y (F01) . . . . .	68
9. 13.	Control Motor Ass'y (F02) . . . . .	68
9. 14.	Head Mount Base Ass'y (F03) . . . . .	68
9. 15.	Supply Pressure Roller Ass'y (F04) . . . . .	69
9. 16.	Take-up Pressure Roller Ass'y (F05) . . . . .	69
9. 17.	Head Base Ass'y B (F06) . . . . .	69
9. 18.	Cassette Case Holder L Ass'y (F07) . . . . .	69
9. 19.	Cassette Case Holder R Ass'y (F08) . . . . .	69

9. 20.	Auto Shut-off Ass'y (F09)	69
9. 21.	Pneumatic Damper Ass'y (F10)	70
9. 22.	P-8L Playback Head Ass'y (G01)	71
9. 23.	R-8L Record Head Ass'y (G02)	71
10.	Overall Timing Chart	71
11.	Eq. Amp. Frequency Response	72
11. 1.	Playback Frequency Response	72
11. 2.	Record Current Frequency Response	72
12.	Wiring Diagram	73
13.	Block Diagrams	75
13. 1.	Amplifier	75
13. 2.	Mechanism Control	76
14.	Schematic Diagrams	77
14. 1.	Amplifier	77
14. 2.	Mechanism Control	78
15.	Remote Control Unit RM-580 (Optional)	81
15. 1.	Mounting Diagrams and Parts List	81
15.1.1.	Receiver	81
15.1.2.	Transmitter	82
15. 2.	Schematic Diagrams	82
15.2.1.	Receiver	82
15.2.2.	Transmitter	82
15. 3.	Adjustments	83
15.3.1.	Transmitter	83
15.3.2.	Receiver	83
15.3.3.	Performance Check of Transmitter and Receiver	83
15. 4.	Mechanism Ass'y and Parts List	83
15.4.1.	Receiver	83
15.4.2.	Transmitter	84
16.	Specifications	85

## 1. GENERAL

### 1.1. Control Functions

Nakamichi 582 control functions are shown below:

- |   |  |
|---|--|
| 1. Acrylic Cassette Compartment Cover   | 18. Output Level Control                     |
| 2. Cassette Lid                         | 19. Play Button                              |
| 3. Eject Button                         | 20. Stop Button                              |
| 4. Counter Reset Button                 | 21. Rewind Button                            |
| 5. Tape Counter                         | 22. Fast-Forward Button                      |
| 6. Bias Adjustment Controls             | 23. Record Button                            |
| 7. Record Calibration Controls          | 24. Pause/Cue Button                         |
| 8. Tape Start Memory/Timer Switch       | 25. Head Height and Azimuth Alignment Screws |
| 9. Tape Switch (EX/SX/ZX)               | 26. Headphone Jack                           |
| 10. Eq. Switch (120 $\mu$ s/70 $\mu$ s) | 27. Input Jacks                              |
| 11. Test Tone Switch (400 Hz/15 kHz)    | 28. DIN In/Out Connector                     |
| 12. Dolby NR/MPX Filter Switch          | 29. Output Jacks                             |
| 13. Monitor Switch                      | 30. DC Output Jack                           |
| 14. Power Switch                        | 31. Remote Control Socket                    |
| 15. Peak Level Meters                   | 32. Voltage Selector                         |
| 16. Input Level Control (Record Level)  | 33. Power Cord                               |
| 17. Balance Control                     |  |

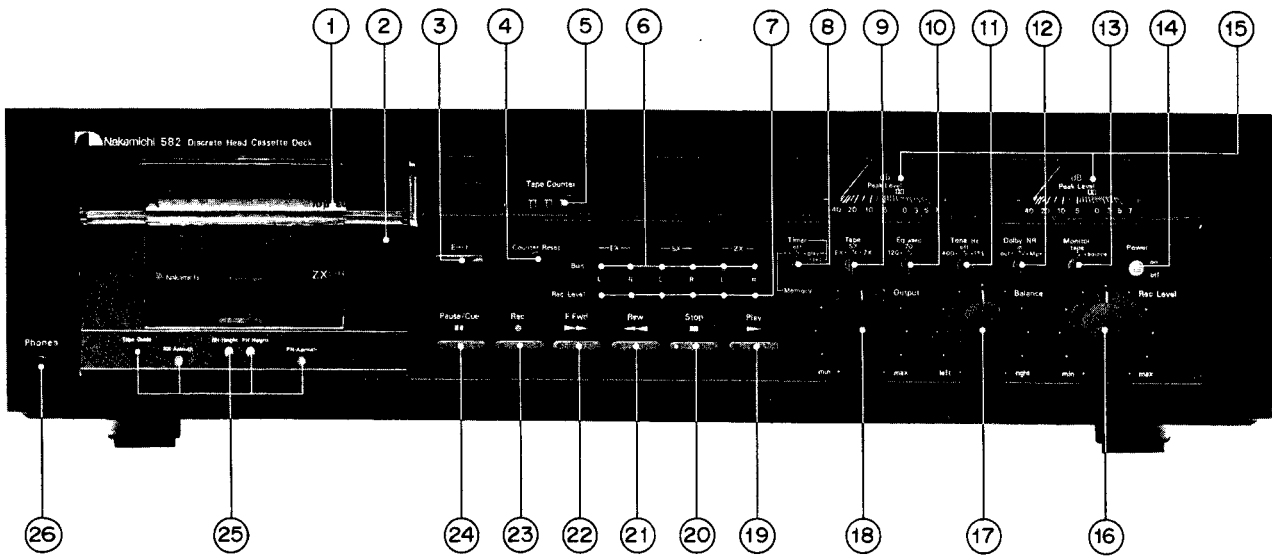

Fig. 1.1 Front View

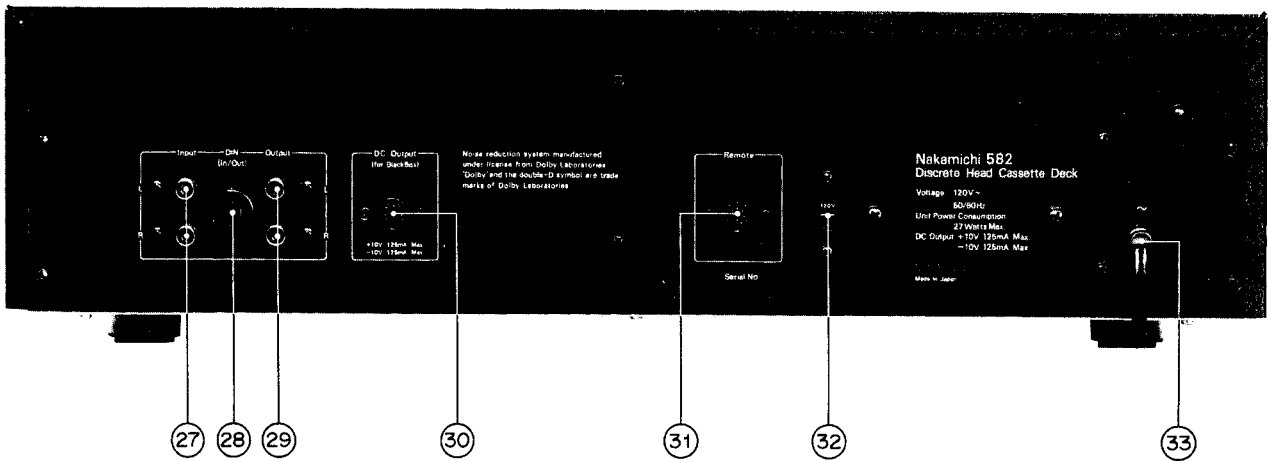

Fig. 1.2 Rear View

**1.2. Voltage Selector**

Voltage selector is installed on the rear panel for other versions of the Nakamichi 582. This voltage selector can select either 120 V or 220 – 240 V at customer's disposal.

## 2. PRINCIPLE OF OPERATION

### 2.1.1. 3-Head Configuration

N-582 is a Discrete Head Cassette Deck which contains a Playback Head, Record Head and Erase Head within a double-capstan closed-loop. Since it contains three heads, with narrow gap for Playback Head and wide gap for Record Head, N-582 has excellent playback and recording characteristics. Three Heads, because they are installed in the double-capstan closed-loop, can result adequate tape tension and stable tape drive.

Accuracy of tape travel is one of the most essential factors for a device to optimize its performance. Inaccurate tape travel will therefore induce deterioration exemplified by the following:

- (a) vibration will be given to tape travel, as a result of which flutter and modulation noise will become increased
- (b) insufficient tape-to-head contact will result in level drops
- (c) tape skew will become greater and frequency response will become decreased

Needless to say, constant tape travel must consist of smooth drive mechanism, as well as of the fact that tape, heads and tape guide are placed in the most appropriate positions.

#### (1) Playback Head

Even if an azimuth misalignment is noted because of tape skew, deterioration of performance has been greatly reduced upon decreasing the gap of the Playback Head to narrow. The gap of this Playback Head is 0.9 micron. Where gap width is decided to be  $d$ , it is publicly known that the gap loss  $L_d$  is obtained by the following formula:

$$L_d = 20 \log \frac{\sin \frac{\pi d}{\lambda}}{\frac{\pi d}{\lambda}} \text{ (dB)}$$

Legend:  $d$  = Gap width of Playback Head  
 $\lambda$  = Recording wave length  
 ( $\lambda = v/f$ ,  $v$  = Tape speed)

The Playback Head employed a narrower gap, and is of crystal permalloy (same as SuperHead which is used in N-600II and N580). The narrower gap head resulted in decreasing loss against frequencies at highs and an improvement of frequency response.

Where there should be any azimuth misalignment, it would equivalently be converted to gap loss and will give affect to frequency response.

Fig. 2.1.1 shows equivalent gap width, Fig. 2.1.2 azimuth misalignment at frequency of 20 kHz vs azimuth loss (playback output loss) when gap width is considered to be parameter, and Fig. 2.1.3 shows frequency vs azimuth loss when azimuth misalignment is considered to be a parameter.

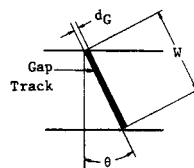

$$\text{Loss} = 20 \log \frac{\sin \frac{\pi d}{\lambda}}{\frac{\pi d}{\lambda}} \text{ (dB)}$$

$\lambda = v/f = \text{Tape Speed}/20 \text{ kHz} = 2.375 \mu\text{m}$   
 $d \approx d_G + W \sin \theta$   
 $d_G$ : Gap Width =  $0.9/1.5 \mu\text{m}$   
 $W$ : Track Width =  $600 \mu\text{m}$

Fig. 2.1.1 Equivalent Gap Width

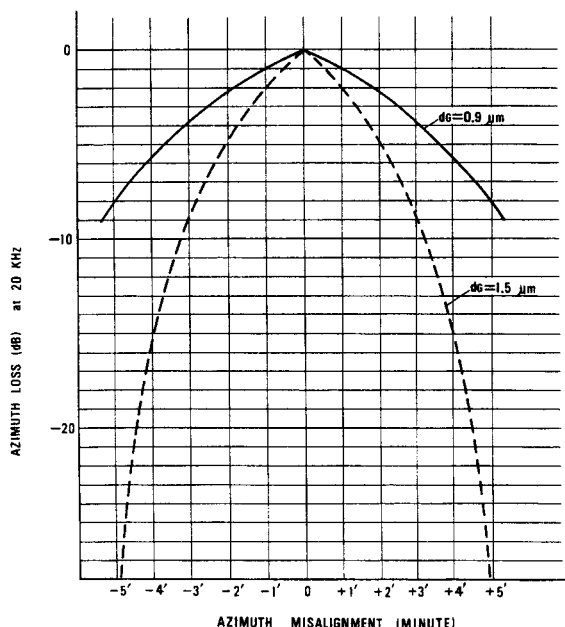

Fig. 2.1.2 Azimuth Misalignment vs Azimuth Loss (Playback Output Loss) at 20 kHz

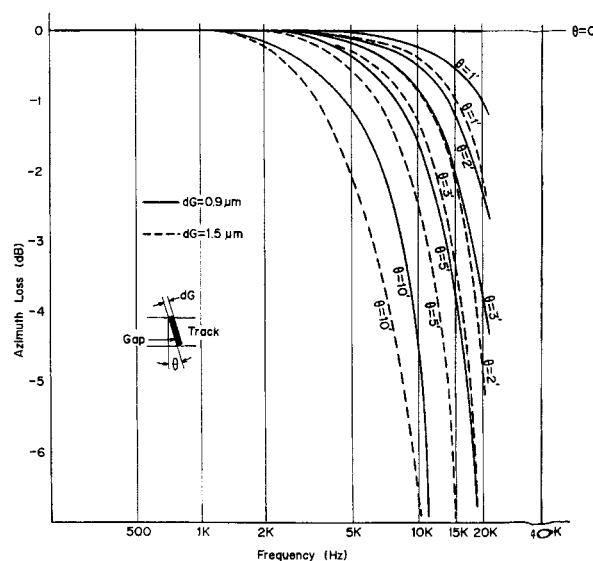

Fig. 2.1.3 Frequency vs Azimuth Loss

## (2) Record Head

N-582 Record Head is of crystal permalloy, same material as Playback Head's, but with the gap of 3 microns.

In order to reduce the distance between Playback Head and Record Head, the latter is made very small. Further it is designed to bring the gap out of center. Also, the surface of the latter is made not symmetrical in shape. All these bring about excellent effect in tape travel and recording characteristic.

## (3) Erase Head

Fig. 2.1.4 shows the sectional view of Erase Head.

Fig. 2.1.5 shows the characteristics of erasing current and erasure.

It has the same characteristics with N-580's Direct-Flux Erase Head but been purposely developed to minimize the size further.

Conventional Erase Head had its inside core narrower than its outside core, while this Erase Head is equipped with an inside core wider than the outside core. This has resulted more power sufficient enough for erasing even Metal Tape with small power consumption, approx. 0.5 W, though the head width is as small as 3 mm. The smaller the power consumption is, the smaller will be the heat generation, and this is of course another merit.

## (4) Headblock

Refer to Fig. 2.1.6.

N-582 Playback Head and Record Head, they are both made small in size so that the both heads are assembled in a space of the conventional Record/Playback Head. Erase Head is located at the place where the Record Head is located in the N-700II/1000II.

Both Playback Head and Record Head are assembled on the Head Mount Base. Take-up Tape Guide and Supply Tape Guide are fixed to the Take-up Pressure Roller Arm and Supply Pressure Roller Arm, respectively. Erase Head is placed on the Head Base. All these can be separately adjusted.

Record Head is placed slightly backward, approximately 0.15 mm away from the Playback Head. Record Head is placed approximately  $3^\circ$  inclined leftward. Shape of the Heads and its location have been carefully studied to bring about smoother contact of tape with the Heads. Pad Lifter is affixed to the Playback Head so as not to let Tape Pad touch the Head to give more stabilized tape travel, making it free from the influence of the Tape Pad within the Cassette Tape. Thus the trouble of changes in azimuth can now be avoided at changing of cassette tape, if only the Record Head azimuth is properly adjusted in advance.

The Fig. 2.1.7 shows trackings of each head against a tape of the N-582, wherein the figure shows ideal locations at the time of designing, thus the tracking in actual use will vary more or less, depending upon the tape width, etc.

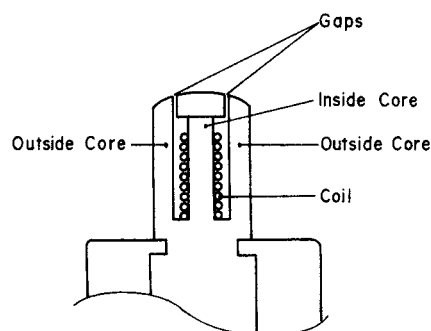

Fig. 2.1.4 Sectional View of Erase Head

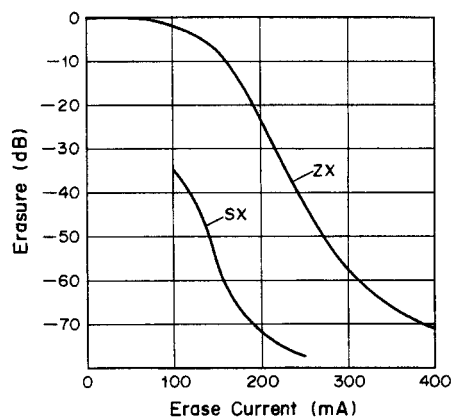

Fig. 2.1.5 Characteristics of Erasing Current and Erasure

### (a) Adjustment of Tape Guide Height

Tape Guide of the N-582 is assembled into the Take-up and Supply Pressure Roller Assemblies. With a spring in the stud of Mechanism Chassis Ass'y, Pressure Roller Ass'y is tightly affixed with Tape Guide Adjustment Nut. The Adjustment Nut is placed on a spring through Pressure Roller Arm, and therefore by either tightening or loosening adjustment the height of the Tape Guide will become possible.

### (b) Playback Head Height Adjustment and Azimuth Alignment

Azimuth and height of Playback Head can be made independently and adjustment may be done separately without affecting others. In order to adjust the tilt of Playback Head backwards or frontwards, take off the Height Gear Stopper and take out the Height Gear and then turn the two Height Adjustment Screws. After the adjustment is done, place the Height Gear back and fix it with the Height Gear Stopper. After the tilt is adjusted in such a way as above, adjust the height by loosening or tightening the Height Gear. Azimuth alignment is adjusted by loosening or tightening the PH Azimuth Screw. This system has been carefully designed so as to minimize influence each other between azimuth and height adjustment.

### (c) Record Head Height Adjustment and Azimuth Alignment

Record Head tilt adjustment can be performed in the same way as for the Playback Head.

Height adjustment can be adjusted while recording 400 Hz test tone by loosening or tightening RH Height Adjustment Screw to obtain the maximum level on the both Level Meters. Azimuth alignment can be adjusted while playing back 15 kHz test tone by loosening or tightening RH Azimuth Alignment Screw to obtain the maximum level on the both Level Meters.

This system has also been carefully designed so as to minimize influence each other between azimuth and height adjustment.

### (d) Erase Head Height and Tilt Adjustment

Erase Head is affixed onto the Erase Head Plate which is assembled with the Head Base. It is installed with three screws. By turning these screws, its height, tilt of backward or frontward, and tilt of leftward or rightward can be adjusted separately, thus the best location of Erase Head can be obtained.

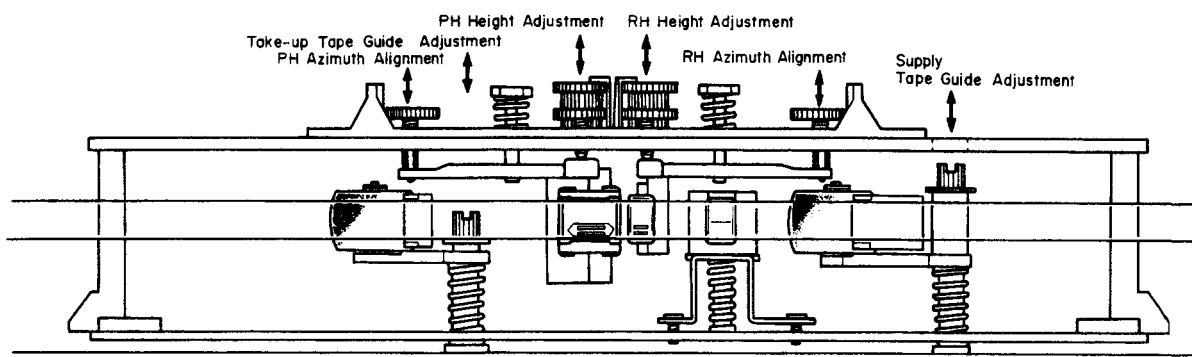

Fig. 2.1.6 Headblock

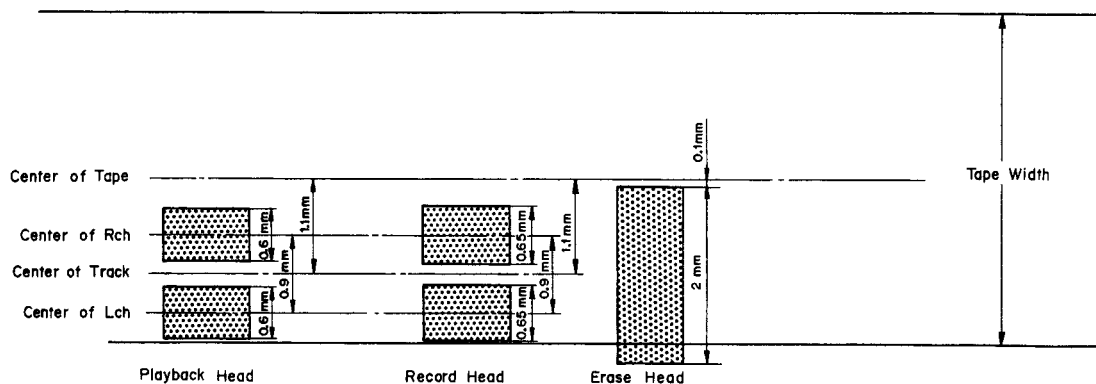

Fig. 2.1.7 Trackings

### 2.1.2. Double Capstan Tape Drive

As shown in Fig. 2.1.8, the double capstan system consists of two capstan shafts (a) and (b) connected to the two flywheels which are driven by a capstan belt.

Against these capstans two pressure rollers (a) and (b) are engaged to run the tape with an adequate holdback tension created by the double capstan and pressure rollers.

Since the diameter of capstan shaft (a) is smaller than that of capstan shaft (b), when two flywheels begin to turn as shown in the figure, capstan (a) runs slightly faster than capstan (b), which subsequently generates holdback tension.

As you note, if the diameters of the 2 capstans should be the same, the generation cycles of wow and flutter will become approximately the same, as a result of which defe-

ctive portion will be doubly superposed and preferable portion vice versa. The N-582 employs 2 capstans, each having different diameter and rotations, thereby avoiding the aforesaid occurrence and stabilizing wow and flutter characteristics.

As the double capstan system always creates a constant and stable holdback tension between the two capstans, the condition of the tape between two capstans will not be affected by any external conditions such as irregular take-up and supply torques, irregular loading of cassette tape, undesirable mechanism vibration and etc, thus assuring the superior wow and flutter characteristics. The double capstan system provides a constant holdback tension on the tape and maintains the stable pressure onto the tape against the heads.



The only critical factor in the double capstan system is to be considered; the two capstans have to be positioned perfectly in parallel and to be precisely vertical against the head base, the pressure rollers have to be evenly pressed

against the capstan shafts and the head surface must be positioned perfectly vertical to the tape surface. Otherwise, the running tape might become out of the tape guide resulting in irregular movement.

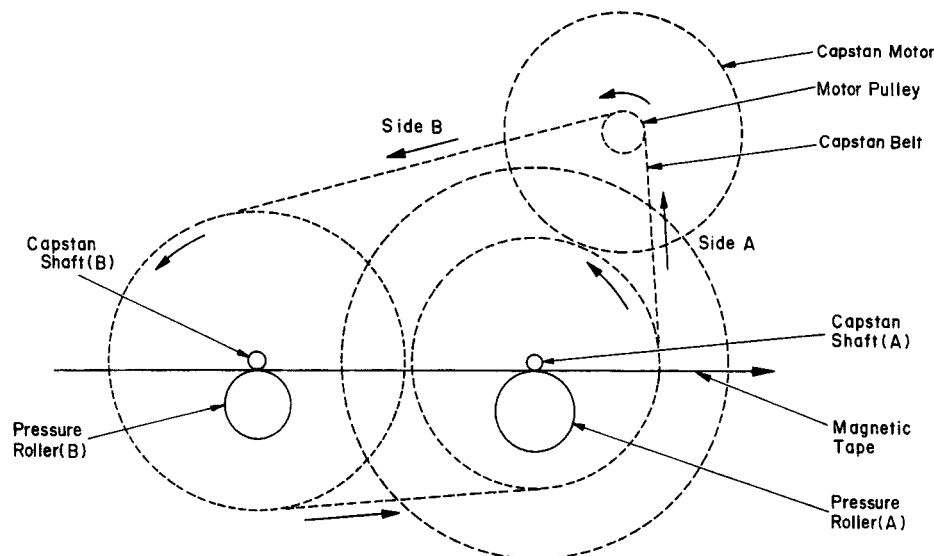

Fig. 2.1.8 Double Capstan Tape Drive

### 2.1.3. Mechanism Control Cam Operation

Refer to Fig. 2.1.4 Mechanism Cam Control timing chart. Function of N-582 Mechanism is done by Cam Control. Cam is driven by the Control Motor. The Motor operates so as to result zero in the difference of voltages between each voltage corresponding to mechanism function and each reference voltage which corresponds to each commands of the Control Switch. When the difference comes to zero, then it stops. In this way, each function is kept properly operated. For further details, please see the explanation on Logic Control. Here we explain principle of its mechanical functions.

Cam Control System works as follows: Cam Drive Gear is driven by Control Motor by means of Drive Belt. Cam Drive Gear is related to the cam with which each function may be mechanically set on.

#### (1) Play Mode

Press the Play Switch to make it Play mode. Then the Cam begins to move from Stop position to Play position and the Play mode will be set.

The Head Base which is linked to the Cam and which is normally pushed against the Stop Position gets released and the Head Base will slowly come out for playing. To explain this function, first the Head Base is latched and the Reel Motor begins to turn. Then the Pressure Roller will be pushed and the Brake will be released. Now the tape begins to run. If you press the Pause Switch at this stage, it comes to Pause mode. Brake operates and the Pressure Roller moves away from the Capstan and the

Reel Motor stops.

Play mode may be changed to Stop mode by pressing the Stop Switch, and latch of the Head Base being released. The Cassette Case cannot be opened because of the latched eject effect unless it is in Stop mode.

#### (2) Record Mode

By pressing the Record Switch and the Pause of Play Switch, it may be made to Record mode. The Cam at this moment moves from Stop position to Rec. position. At the same time, Rec. Trigger Mechanism is driven and the Record Switch on the Main P.C.B. is switched on to the Record side. Further, the Cam turns until it comes to the Pause or Play position. On the other hand, the Rec. Trigger Mechanism is released during this process. When the Cam is set in Rec./Pause or Rec./Play position, Record signals will be sent to Bias Oscillating Circuit from Logic Control Circuit to let the Bias to oscillate.

Press the Stop Switch and the Cam comes back to the Stop position. At the same time, it will set the Record Switch on the Main P.C.B. to the Play side.

#### (3) F.F. or Rewind Mode

By pressing F.F. or Rewind Switch, it comes either to F.F. or Rewind mode. The only difference of these two modes is that one is to turn the Reel Motor reverse and the other to transmit the torque against the Reel Hub onto the take-up side or to the supply side. Brake is released at this stage and the Reel Motor begins to turn F.F. or Rewind.

**(4) Pause Mode**

Press the Pause Switch to make it to Pause mode. In changing it from Stop mode to Pause mode, the Brake is first released, then the Head Base is latched, and again the Brake works.

At this stage, the Reel Motor would not turn with the Pressure Roller being apart from the Capstan, and the tape would remain still.

**(5) Cue Mode**

Cue mode may be either of Forward Cue or of Reverse

Cue mode.

In either case, it could be effected by pressing F.F. Switch or Rewind Switch after the Pause Switch has been pressed. The speed of the tape at this moment will be 1/3 the running speed of normal F.F. or normal Rewind. The tape speed will get slow further down to 1/5 the speed of F.F. or of Rewind if you keep on pressing the F.F. or Rewind Switch. In this case, the Brake is released at first and then the Head Base will get latched at the Cue position and the Reel Motor will start while the Pressure Roller remains apart from the Capstan.

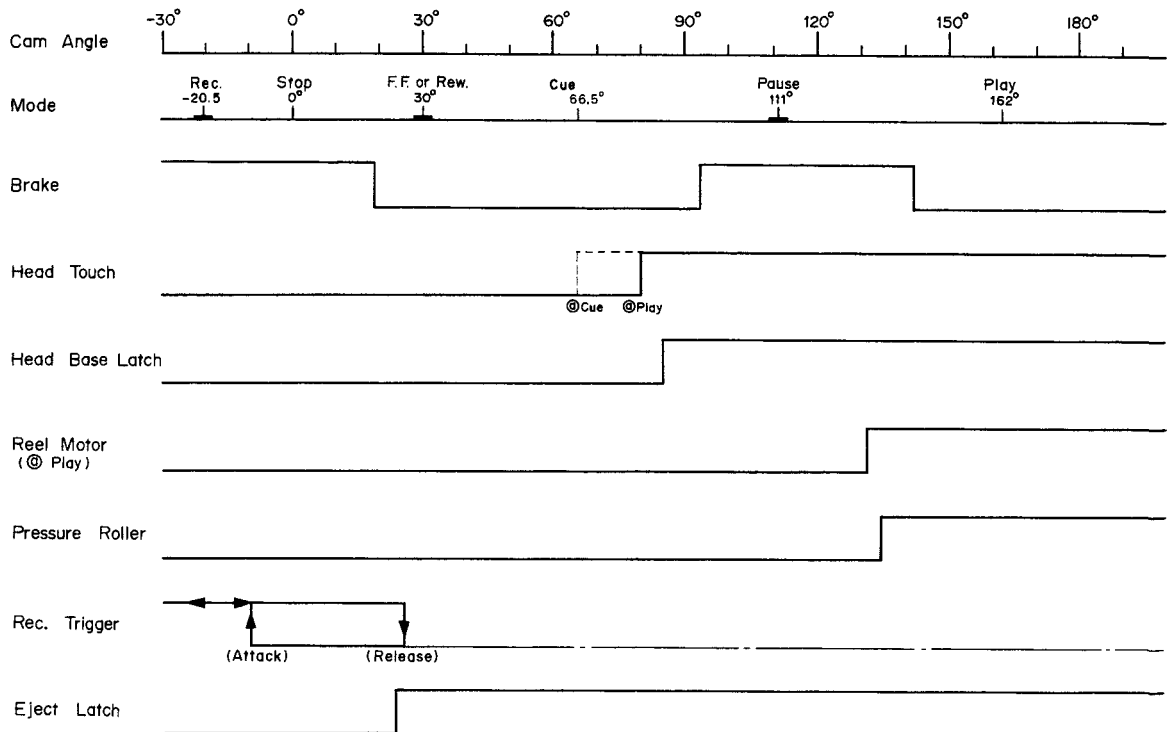

Fig. 2.1.9 Mechanism Control Cam Timing Chart

**2.2. Amp. Circuits**

**2.2.1. Playback Eq. Amp. Circuit**

Fig. 2.2.1 shows playback equalizer amp. circuit.

Fig. 2.2.2 shows its system diagram, and Fig. 2.2.3 shows time constant of equalizer.

Playback Head is connected to the input of this circuit. Amplifier, which is composed of Q105, 106 and 107, is an equalizer amplifier and its time constant is shown in Fig. 2.2.3. R147, R148, L105 and C139, which consist of peaking circuit, compensate Playback Head gap loss and improve frequency response at high. L105 and C138 compose bias trap circuit and prevent bias leakage from playback eq. amp. circuit. L105 is of variable type and adjustment performed by L105 is mainly for the purpose of reducing bias leakage.

Playback eq. amp. gain adjustment should be performed so as to obtain 100 mV at TP101 (TP201) by adjusting

VR102 (VR202) during the course of playing back 400 Hz Level Tape (DA09005A). Eq. Switch (70 μs/120 μs) is connected to playback eq. amp. circuit and the overall time constant of playback eq. amp. circuit will become as follows:

$$\text{Eq. Switch} - 70 \mu\text{s}: 3180 \mu\text{s} (50 \text{ Hz}) + 70 \mu\text{s} (22.4 \text{ Hz})$$

$$\text{Eq. Switch} - 120 \mu\text{s}: 3180 \mu\text{s} (50 \text{ Hz}) + 120 \mu\text{s} (13.6 \text{ Hz})$$

Following table shows tapes used at each Tape Switch combined with Eq. Switch.

Tape SW	Eq. SW	Tape
ZX	70 $\mu$ s	Nakamichi ZX
SX	70 $\mu$ s	Nakamichi SX, TDK SA, Maxell XL-II Scotch Master 70 $\mu$ s
EX	120 $\mu$ s	Low-Noise High-Density (including EX, EXII, TDK AD, Maxell XL-I, Scotch Master 120 $\mu$ s)
	70 $\mu$ s	Nakamichi EX, EXII

It is specified in IEC Standard that time constant is 120  $\mu$ s on tapes of ferric oxide, and 70  $\mu$ s on tapes of CrO2.

However, in the case of Eq. Switch on N-582, when time constant at playback is changed, at the same time time constant at record must also be changed. Therefore, even though record and playback is made by the method other than the IEC Standard, no deterioration of frequency response or level difference will occur. (Any other method for instance, record and playback on ferric oxide tape with putting Tape Switch on EX and Eq. Switch on at 70  $\mu$ s.) When Nakamichi EX or EXII Tape is used at Tape Switch: EX, and Eq. Switch: 70  $\mu$ s, S/N ratio will be improved by approximately 4 dB (WTD).

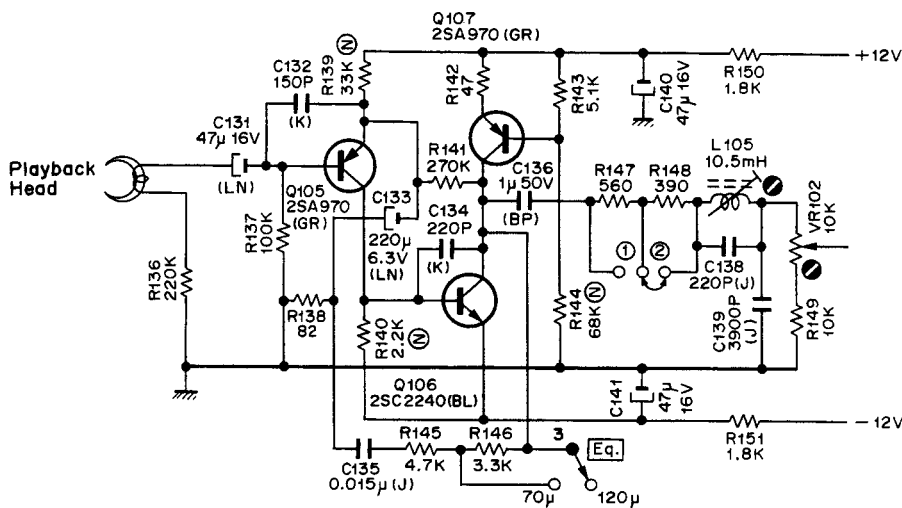

Fig. 2.2.1 Playback Eq. Amp. Circuit

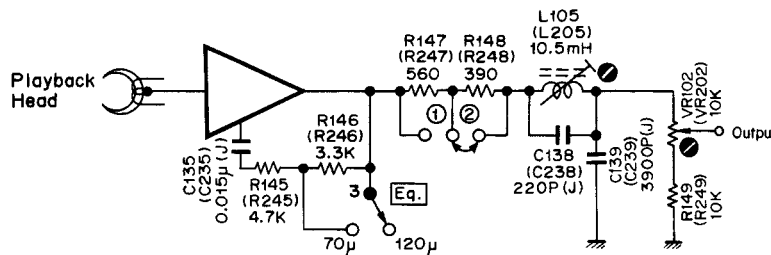

Fig. 2.2.2 System Diagram

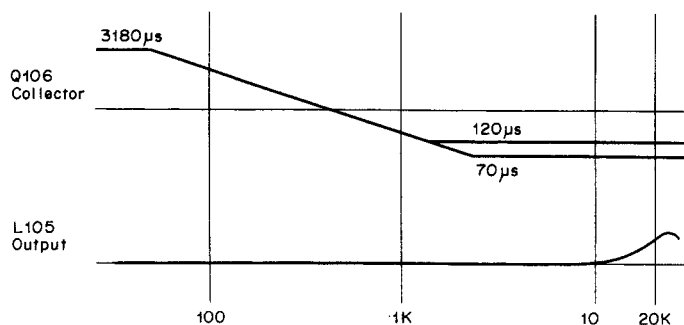

Fig. 2.2.3 Time Constant

**2.2.2. Record Amplifier Circuit**

Fig. 2.2.4 shows record amplifier circuit which employs a low noise operational amplifier IC.

This circuit adopted the direct coupling system (the DC amp. output is connected directly with the Record Head). Direct coupling system provides improvements of linearity and phase characteristic at low frequency, less distortion (as a clipping level becomes higher), etc.

This record amp. is muted with record signal from Logic P.C.B. Ass'y and also with mute signal.

With the exception of record mode, input and output of record amp. is muted simultaneously. At record mode, when mute signal is given from Logic P.C.B. Ass'y, input of record amp. will be muted.

**2.2.3. Bias Oscillation Circuit**

Fig. 2.2.5 shows a push-pull oscillator with an oscillation frequency of 105 kHz which is constructed by capacitors C316 and C317, coupling the collectors and bases of two transistors (Q301 and Q302).

This is used to provide recording bias and as an erase signal.

By pressing the Record and Pause, or Record and Play Buttons, Rec. signal conducted from the Logic P.C.B. Ass'y becomes L, and Q303 turns to ON.

Therefore, +12 V is applied to the circuit through Q303, as a result of which oscillation begins.

When the record mode is released, oscillator output is damped by the discharge of C315. This prevents magnetization of the Record Head.

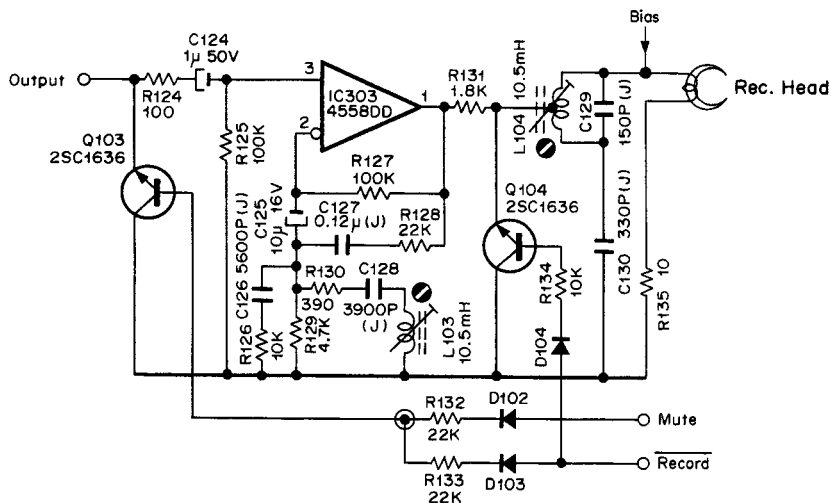

Fig. 2.2.4 Record Amp. Circuit

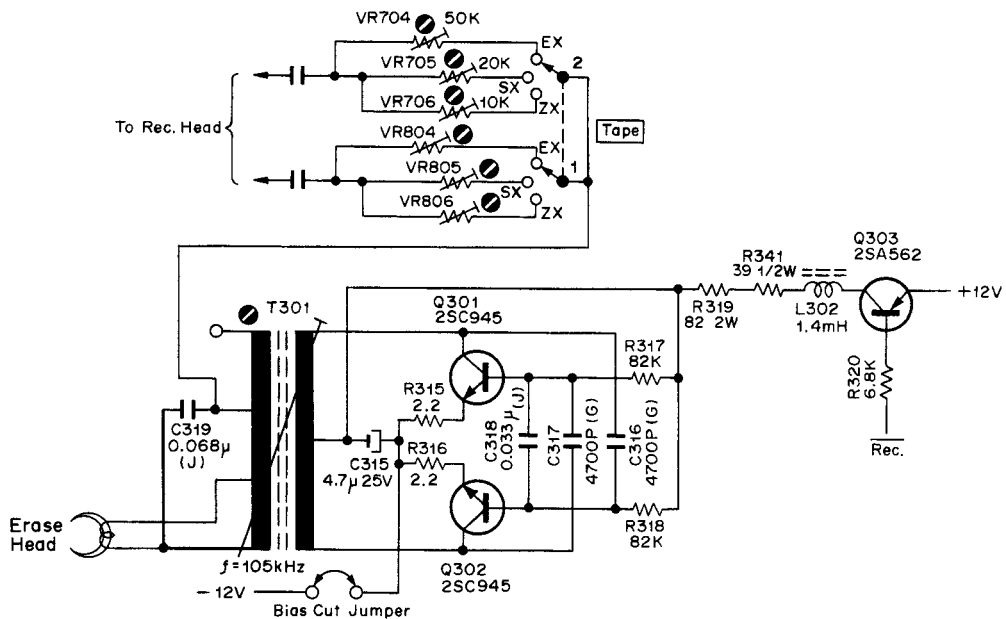

Fig. 2.2.5 Bias Osc. Circuit

**2.2.4. Test Tone Circuit**

By means of the operational amplifier IC, the N-582 oscillates 2 kinds of tones, which are 400 Hz (0 dB) for record level calibration and 15 kHz (-20 dB) for bias calibration.

At 15 kHz, VR103 is added to R162 and VR104 in parallel so as to have IC304 gain increased by 20 dB. This is the cause of indication of 0 dB on the Level Meter.

As shown in Fig. 2.2.6, the test tone consists of oscillation portion through IC RC4558D and band pass filter comprising either of 400 Hz or 15 kHz, and either of 400 Hz or 15 kHz can be selected by the Test Tone Switch.

Power will be supplied to the test tone circuit when Power Switch is set to ON.

IC301-1/2 consists of oscillation function, feeds its output back to input and oscillated square wave up to power source voltage level so that the oscillation voltage can be stabilized. A capacitor is connected to No. 6 terminal of the IC301-1/2 for convenience while changing over one frequency to another (400 Hz: 0.0114  $\mu$ F, 15 kHz: 200 pF).

Band pass filter is created between IC301-1/2 and 2/2, and the sine wave of the selected frequency will be obtained at the output terminal 1 of the IC301-2/2. With regard to band pass filter curve, refer to Fig. 2.2.7.

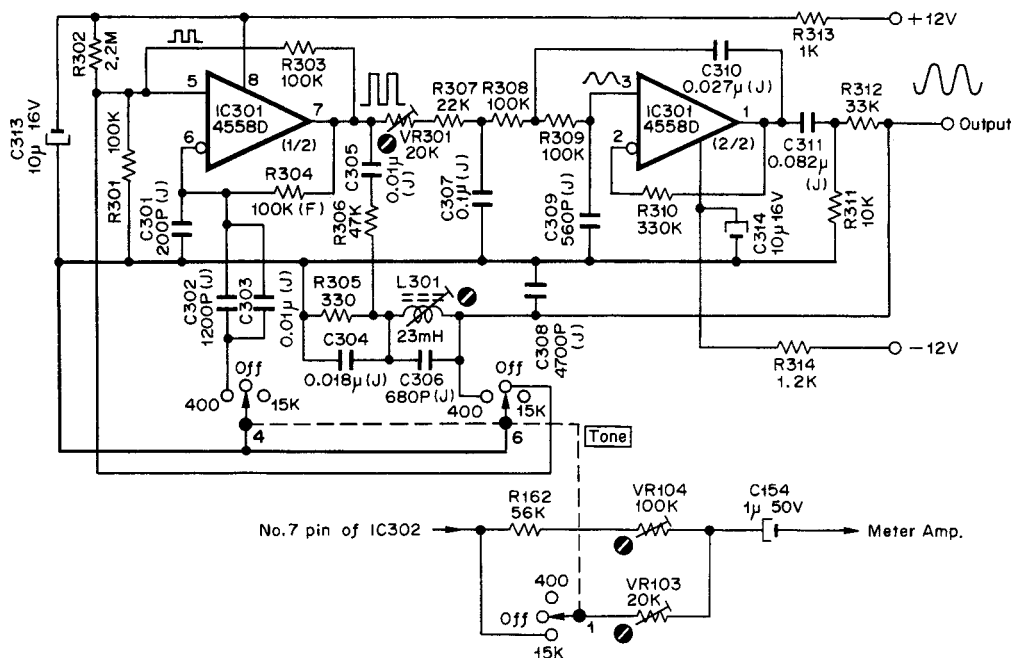

Fig. 2.2.6 Test Tone Circuit

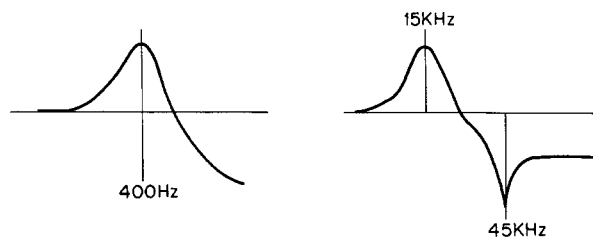

Fig. 2.2.7 Band Pass Filter Curve

## 2.3. Mechanism Control Circuits

### 2.3.1. Logic Control

Refer to Fig. 13.2 block diagram for mechanism control circuits.

#### (1) C-MOS IC

##### (a) Features of C-MOS IC

The IC's used in the logic circuit of the N-582 are of the C-MOS (complementary metal oxide semiconductor) type, in which P-channel and N-channel MOS FET's complement each other.

#### 1) Small power consumption

A C-MOS is an inverter, as shown in Fig. 2.3.1.

Whether the input of this inverter is at "H" or "L" level, either the P-channel or N-channel MOS FET is OFF, and therefore, current does not pass from VDD to VSS under steady normal state. Consequently, when there is no input, power consumption ( $V_{DD} \times I_{DD}$ ) is nearly zero, except for surface and junction leakage.

When the input signal is switched from "H" to "L", or "L" to "H", however, both P- and N-channel FET's instantly come on, and a current flows either charging or discharging the stray output capacity, so that the power consumption during dynamic operation cannot be said to be zero.

#### 2) A large noise margin

The input-output transmission characteristics of the C-MOS inverter differ from those of bipolar IC's as shown in Fig. 2.3.2. The knee characteristic is sharper, the threshold voltage is almost half of VDD, and the output amplitude is nearly equal to  $V_{DD} - V_{SS}$ .

Since the noise margin of a digital IC is defined as the difference between the minimum value of output amplitude and the minimum required amplitude of the input signal, it is quite natural that the C-MOS circuit, which produces an output amplitude of nearly  $V_{DD} - V_{SS}$  and is operated by a small input signal, should have a large noise margin.

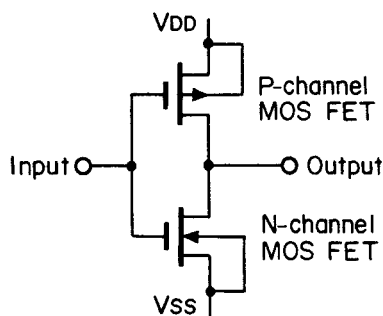

Fig. 2.3.1

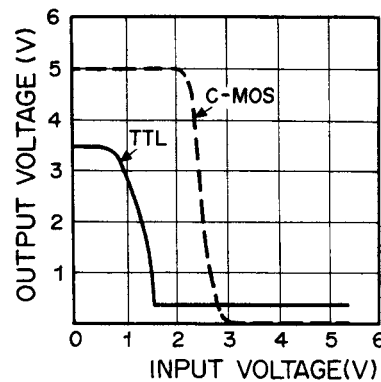

Fig. 2.3.2

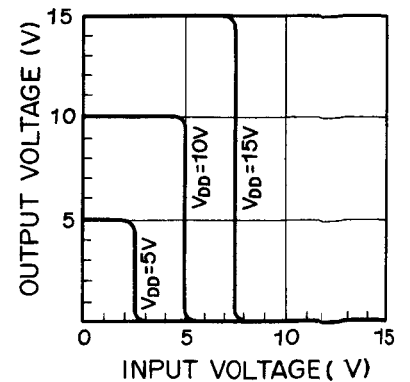

Fig. 2.3.3 Input-Output Transfer Characteristics of C-MOS

#### 3) High input impedance

A C-MOS IC has a very high input impedance because it is insulated from the substrate by the oxide film of the gate. Although leakage resistance must be considered in an actual C-MOS IC because diodes are usually used in the direction of reverse bias for protecting input circuit, its impedance is several tens of megohms. The advantage of a high input impedance is that the fan-out of the IC is large, which simplifies the interface. Also, a timer circuit for a longer period of time can be produced. This means that the high input impedance enables the input to be connected with a large resistance, but does not mean to use a capacitor of large capacity.

#### 4) Wide operating voltage range

Fig. 2.3.3 shows input-output transfer characteristics of C-MOS. The general purpose C-MOS family has a wide operating voltage range extending from 3 to 18 V, which is much wider than that of TTL and DTL ( $5 \pm 0.25$  V), and HTL ( $15 \pm 1.5$  V). The reason for the C-MOS IC's wide operating voltage range is that the P-MOS and N-MOS are made symmetrical, and if VDD is varied, the threshold voltage for the circuit is always about half of VDD. In a bipolar IC, the threshold voltage is decided by the forward voltage from the base to the emitter of the transistor ( $V_{BE}$ ), and is little affected by the source voltage. Therefore, if the source voltage exceeds a certain limit, the output voltage and the threshold voltage will not balance, as a result of which operation will become impossible.

With a C-MOS, the threshold voltage varies according to changes in the source voltage, and stable operation throughout a wide range can be expected. As indicated above, the performance of a C-MOS IC as a digital IC is excellent.

**(b) Gate Logic**

2-input NOR and NAND gates are used.

Following shows each logic symbol, truth table, pin assignment, and internal schematic diagram.

**1) NOR Gate**

The output will be H only if inputs IN1 and IN2 are L's, and the output will be L if IN1 is H or IN2 is H.

(H: +12 V, L: 0 V)

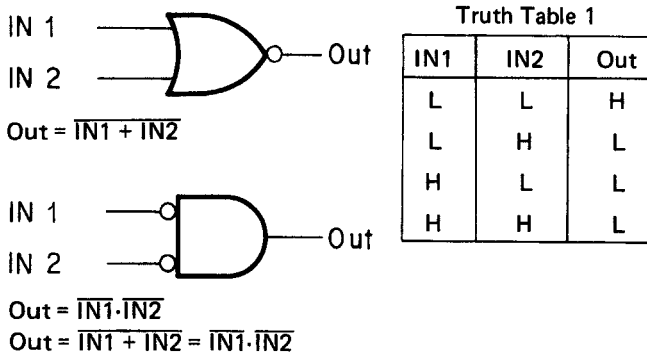

Fig. 2.3.4

The construction of the foregoing 2 Logic Symbols is identical and intended to show the use of either OR or AND.

**2) NAND Gate**

The output will be L only if inputs IN1 and IN2 are H's, and the output will be H if IN1 is L or IN2 is L.

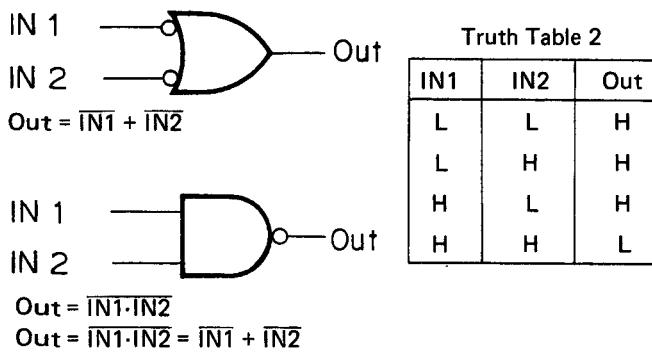

Fig. 2.3.7

The construction of the foregoing 2 Logic Symbols is identical and intended to show the use of either AND or OR.

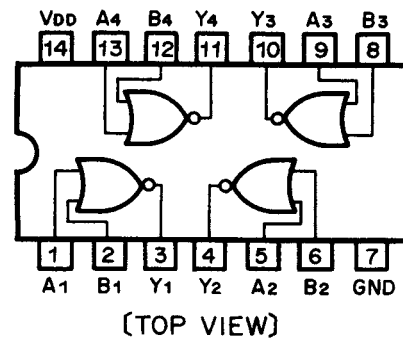

Fig. 2.3.5

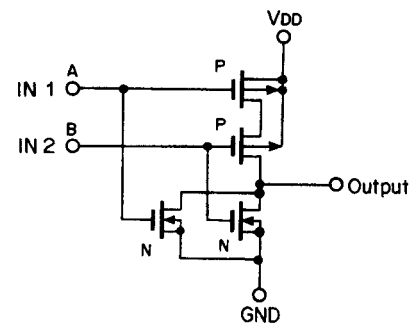

Fig. 2.3.6

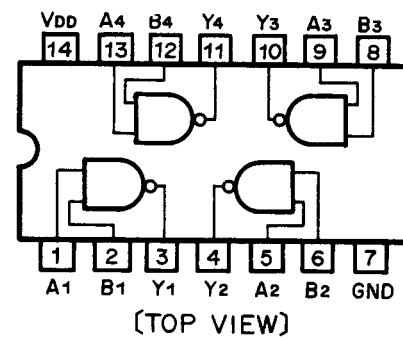

Fig. 2.3.8

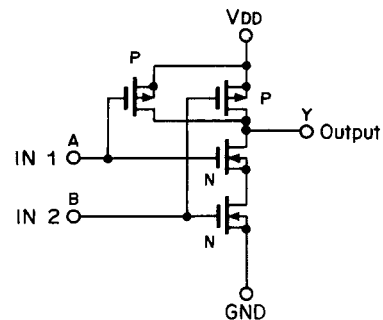

Fig. 2.3.9

**(c) Gated Flip-Flop**

The two NAND gates can be used to form flip-flop. The inputs operate as follows:

When both S and R are H's, the flip-flop will remain in its present state, i.e., will not change the state.

If however, the R input goes to L, the NAND gate connected to R will have H output regardless of the other feedback input to the NAND gate, and this will force the flip-flop to the L state (provided the S input is kept H). Similar reasoning shows that making the S input an L will cause the NAND gate at the S input to have an H output, forcing the flip-flop to the H state (again provided the R input is kept H).

If both inputs R and S are made L's, the next state will depend on which input is returned to H first, and if both are returned to H simultaneously, the resulting state of the flip-flop will be indeterminate. As a result, this is a "forbidden" or "restricted" input combination.

In the actual use, the activation speed of the flip-flop is managed to be delayed in order to prevent erroneous movements caused by noise as shown in Fig. 2.3.11.

Truth Table 3

Set	Reset	Q	$\bar{Q}$	Remarks
L	L	H	H	*: Maintains the previous state.
L	H	H	L	
H	L	L	H	
H	H	*	*	

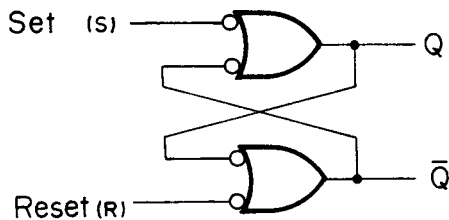

Fig. 2.3.10

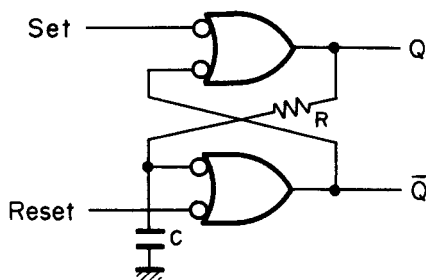

Fig. 2.3.11

**(d) Compatible C-MOS ICs**

IC401, 402, 403 :  $\mu$ PD4011C, CD4011A, MC14011A, F34011A, TP4011A, TC4011P

IC404 :  $\mu$ PD4001C, CD4001A, MC14001A, F34001A, TP4001A, TC4001P

**(2) Logic Control and Other Circuits**

A foolproof operation will be done by logic control. For example, when command the playback mode while fast winding or command fast-forward mode while rewinding, it is guaranteed that no abnormal tape tension will happen by passing through the stop mode. This is also guaranteed even when the switches are pressed simultaneously.

**(a) Logic Signal**

How to read signals is referred to the following: Positive logic is used; the signal H shows the condition that the signal is executing, and in case there is a - on the signal, signal L shows the condition that the signal is executing.

- 1)  $\overline{Kstop}$  (Stop switch output signal)  
 $\overline{Kstop}$  becomes L when the Stop switch is pressed, and  $\overline{Kstop}$  is H while switch is open.  
 In other words,  $\overline{Kstop} = L$  shows while Stop mode is commanded, and  $\overline{Kstop} = H$  shows stop is not commanded.
- 2)  $\overline{PLAY}$  (Play Flip-Flop  $\bar{Q}$  output signal)  
 $\overline{PLAY} = H$ : out of Play mode  
 $\overline{PLAY} = L$ : in Play mode
- 3)  $PLAY$  (Play Flip-Flop Q output signal)  
 $PLAY = H$ : in Play mode  
 $PLAY = L$ : out of Play mode

**(b) Logic Operating Status**

Refer to Fig. 2.3.12 (Logic Status). Each stage of logic status under the series control switch operation is shown in the figure.

**(c) Conditions of Flip-Flops**

- 1) FF Flip-Flop  
 $Set = \overline{Kff}$   
 $Reset = \overline{Kplay} + \overline{Krew} + \overline{Kstop}$
- 2) REW Flip-Flop  
 $Set = \overline{Krew}$   
 $Reset = \overline{Kplay} + \overline{Kff} + \overline{Kstop} + \overline{Memory\ Rewind}$   
 ( $\overline{Memory\ Rewind} = L$ : With Memory switch ON, a differential L pulse generates when the tape counter reaches "999".)
- 3) PLAY Flip-Flop  
 $Set = \overline{Kplay}$   
 $Reset = \overline{Kff} + \overline{Krew} + \overline{Kstop} + \overline{PAUSE}$



## 4) PAUSE Flip-Flop

$$\text{Set} = \overline{K_{\text{pause}}}$$

$$\text{Reset} = \overline{K_{\text{play}}} + \overline{K_{\text{stop}}} + (\text{the rising of the FAST signal})$$

(FAST = FF + REW. When FAST signal becomes H, a differential pulse is generated at the rising of the signal. This pulse conducts Q404 to turn ON, accordingly PAUSE Flip-Flop is reset.)

## 5) REC Flip-Flop

$$\text{Set} = \overline{K_{\text{rec}} \cdot \text{FAST} \cdot \text{PAUSE} \cdot \text{PLAY} \cdot \text{Record Protector Switch OFF}}$$

$$= \overline{K_{\text{rec}} \cdot \text{FAST} \cdot \text{Q405 OFF}}$$

$$(\text{Q405 OFF} = \overline{\text{PAUSE} \cdot \text{PLAY}} \cdot \text{Record Protector Switch OFF})$$

$$\text{Reset} = \overline{\text{PLAY} \cdot \text{PAUSE}} = \text{Q406 ON}$$

MODE	STOP	RECORD				PLAY-BACK	FAST WIND		CUE	
CONTROL SWITCH	STOP	RECORD	RECORD PAUSE	PLAY	PAUSE	PLAY	FF	REW	PAUSE	
	L	L	L	H	L	H	L	L	L	
	H	H	H	L	H	L	H	H	H	
	L	H	H	H	H	L	L	L	L	
	H	H	L	L	L	H	H	H	H	
	L	L	H	L	H	L	L	L	H	
	H	H	L	H	L	H	H	H	L	
	L	L	L	L	L	L	H	L	L	
	H	H	H	H	H	H	L	H	H	
	L	L	L	L	L	L	L	H	H	
	H	H	H	H	H	H	H	L	L	
$\overline{\text{REC}}$ (Q421 Collector)	H	H	L	L	L	H	H	H	H	
MUTE (Q424 Collector)	H	H	L	L	L	L	H	H	L	
$\overline{\text{CUE}}$ (Q426 Collector)	H	H	H	H	H	H	H	H	L	

Fig. 2.3.12 Logic Status

**(d) Initial Reset and Power Mute**

Refer to Fig. 2.3.13 circuit diagram and Fig. 2.3.14 timing chart.

When the power switch is turned ON, the voltage of the power source increases from 0 to +12 V DC. After this voltage is built up, Q403 is turned ON and the mute signal is generated, until C402 is charged through R404, R405, and R406. At the same time, this signal enters the base of Q417 in the automatic shut-off circuit, and turns this transistor ON so that it generates  $\overline{Kstop} = L$  pulse.

When the power switch is turned OFF, the signal from the secondary winding of the transformer entering Q401 soon ceases and Q401 is in the cutoff state. Since the base of Q402 is positively charged, Q402 comes ON, which turns Q403 ON and produces the  $\overline{Kstop} = L$  pulse. The  $\overline{Kstop} = L$  pulse resets each flip-flop to its initial condition (the stop condition).

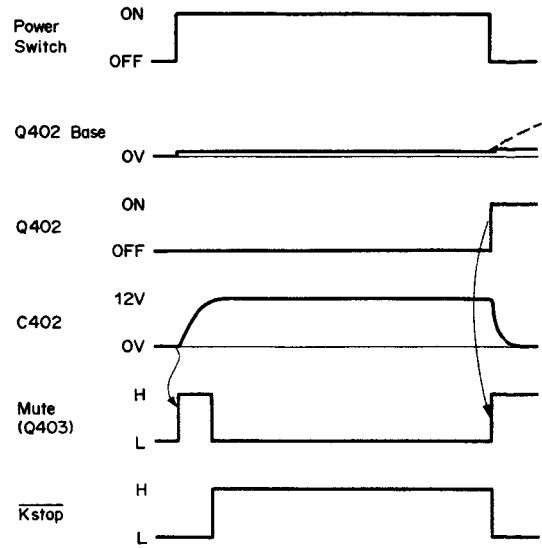

Fig. 2.3.14 Timing Chart

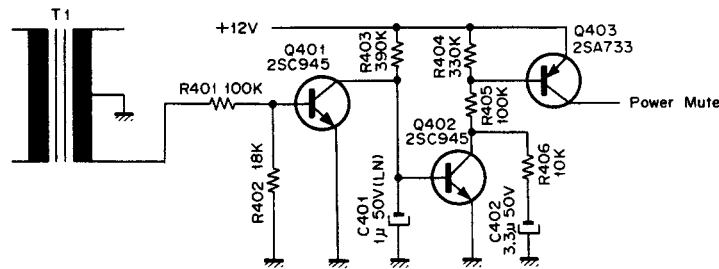

Fig. 2.3.13 Initial Reset and Power Mute Circuit

**(e) One-shot Pulse-generating Circuit**

Refer to Fig. 2.3.15 circuit diagram and Fig. 2.3.16 timing chart.

The circuit consists of IC403-4,5, and 6, IC403-1, 2, and 3, Q407, R420, R421, C412, etc. When the mode is changed as shown below, the circuit generates a one-shot pulse of approximately 400 msec, so that this period passes in the stop mode, and as soon as this is over, a new mode is set:

From FAST (FF or REW) mode to PLAY or PAUSE mode;

From PLAY mode to FAST (FF or REW) mode;

From FF mode to REW mode, or vice versa.

This interval is necessary to avoid an extraneously large tension on the tape, in view of the response of the tape deck mechanism.

**1) From PLAY mode to FF mode**

Since the PLAY flip-flop is set during playing, IC403-6 is H and IC403-5 is L, and therefore, IC403-4 is H and C412 is charged to +12 V. Consequently, IC403-3 is L, and the gates connected to IC403-3 are open.

When the FF switch is pressed the PLAY flip-flop is reset, and at the same time, the FF flip-flop is set. However, the capacitor C413 connected to the PLAY flip-flop retards

so that PLAY = L. Therefore, FF = H and PLAY = H for a short period, and a narrow pulse is produced in IC403-4. C412 is discharged by this L pulse, but it is charged again through R420 and R421 when the L pulse is released.

IC403-3 is maintained at H for approximately 400 msec, until the voltage of C412 exceeds the threshold of IC403-1 and 2, and the gates connected to IC403-3 are closed to bring about the stop condition.

**2) From FF mode to REW mode**

When the REW switch is pressed, the FF flip-flop is reset, and the REW flip-flop is set. As in case 1), a narrow H pulse is generated in the base of Q407, cutting off Q407, and as a result, C412 is discharged through D411. The subsequent actions are the same as in 1).

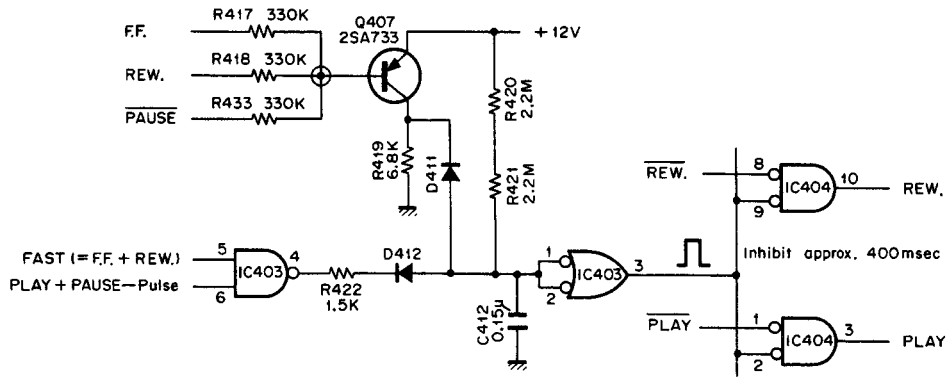

Fig. 2.3.15 One-shot Pulse-generating Circuit

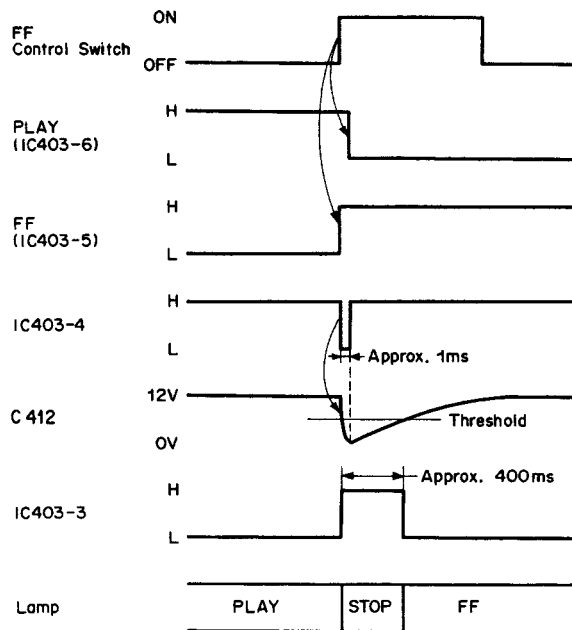

Fig. 2.3.16 Timing Chart

**(f) Unattended RECORD/PLAY**

Unattended recording or playback can be carried out by the use of the Tape Start Memory/Timer Switch. When the power is connected a differential pulse is supplied to Q415 through C420, and Q415 is turned ON. Therefore, when the Tape Start Memory/Timer Switch is moved to

REC side, D424 and D425 are grounded through Q415, and the RECORD mode is selected. When it is moved to the PLAY side, only D425 is grounded, and the PLAY-BACK mode is selected.

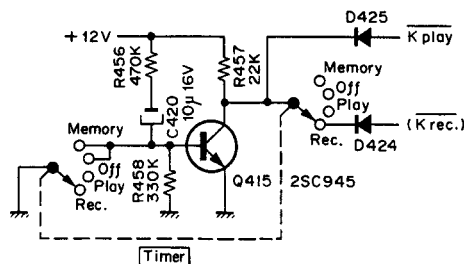

Fig. 2.3.17 Unattended Record/Play Circuit

**(g) REC Signal**

Refer to Fig. 2.3.18. This is the signal that controls bias oscillation in the amplifier circuit. In RECORD/PLAY and RECORD/PAUSE modes,  $\overline{REC} = L$ , and bias oscillation is started. Q421 is turned ON when the REC flip-flop is H and Q422 is OFF, i.e., when the cam selects PLAY or PAUSE mode mechanically, and  $\overline{REC} = L$ .

**(h) CUE Signal**

Refer to Fig. 2.3.18. When the PAUSE switch is pressed during the FAST (FF or REW) mode,  $\overline{CUE} = L$ , and the output level of the amplifier circuit is attenuated. Q426 is turned ON at FAST/PAUSE, thus  $\overline{CUE} = L$ .

**(i) Mute Signal**

Refer to Fig. 2.3.18. When Q424 is ON and when the Mute-power is H through D434, MUTE = H and the amplifier circuit is muted.

$$Q424 \text{ ON} = Q423 \text{ OFF} (= \overline{CUE} \cdot \overline{REC}) \cdot (\text{STOP} + \text{PAUSE} + Q425 \text{ ON (PLAY-Position)})$$

The modes in which the amplifier circuit is not muted are (MUTE = L):

$$Q424 \text{ OFF} = \overline{Q424 \text{ ON}} = \overline{CUE + REC + \overline{\text{STOP} \cdot \text{PAUSE} \cdot \text{PLAY-Position}}}$$

i.e., the FAST/PAUSE (i.e., CUE) mode, RECORD or RECORD/PAUSE mode, and PLAY mode.

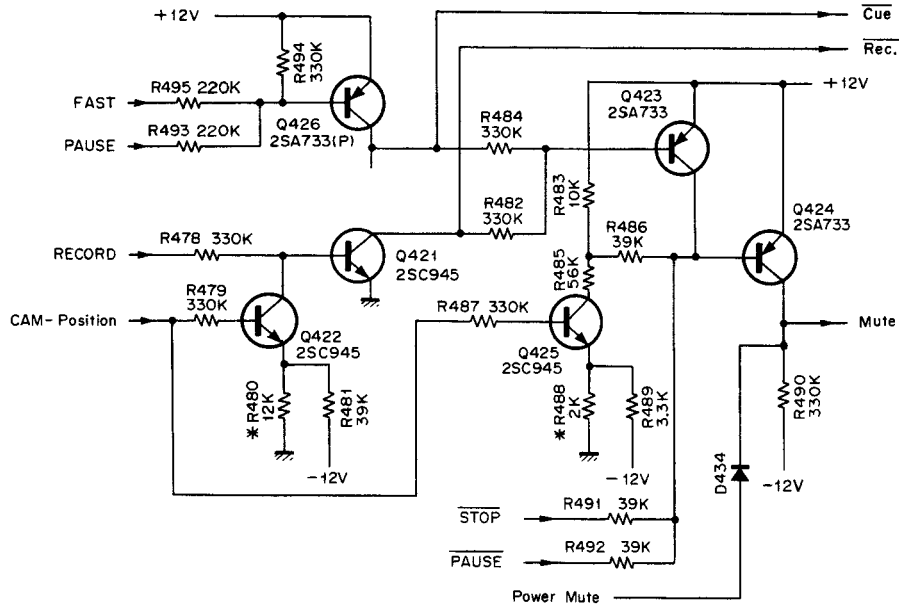

Fig. 2.3.18

**(j) Take-up Function at Loading**

Refer to Fig. 2.3.19. SW503 Eject Switch is closed when eject is made. When a cassette tape is inserted into the Cassette Case Ass'y and loaded, SW503 will become open. Therefore, plus voltage is applied at No. 2 pin of IC402 until C428 (4.7μF 25V) is charged up through R524 (2.2 MΩ).

Accordingly Reel Motor rotates forwardly and eliminates tape loosening of the cassette tape if any.

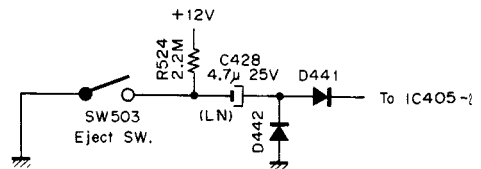

Fig. 2.3.19

**2.3.2. Shut-off Sensor and Detector**

Refer to Fig. 2.3.20 circuit diagram and Fig. 2.3.21 timing chart.

**(1) Shut-off sensor**

Light from lamp PL501 is projected through holes in a disc rotating synchronously with the take-up reel, and the intermittent flashes coming through the disc are converted into electrical signals by a phototransistor (Q602). These signals are amplified into square waves, and transmitted to the shut-off detector in the subsequent stage. When the tape-end comes, the take-up reel and the disc stop rotating, and no pulse is output from the sensor.

**(2) Shut-off detector**

The shut-off detector, which receives the pulse output from the sensor, produces the shut-off signal (i.e.,  $\overline{Kstop} = L$ ) having detected a certain period of absence of pulse, and this signal resets each flip-flop in the logic control circuit.

- (a) Through C421, Q416 is ON and discharges C422 at every H cycle of the sensor output pulse. On the other hand, C422 (1  $\mu$ F) is charged through R461 (2.2 M $\Omega$ ) in the PLAY (Playback or Record) mode or the FAST (FF or REW) mode.
- (b) At the end of the tape, no sensor output is produced and Q416 is not turned ON, resulting in C422 being charged continuously. When the voltage of C422 exceeds the sum of the emitter voltage (approx. 1.1 V) and the VBE of Q417, Q417 is turned ON and transmits the shut-off signal ( $\overline{Kstop} = L$ ) to the logic control circuit.

- (c) In the STOP mode, C422 is grounded through D426 and R459, and the shut-off detection function is made inoperative. When PAUSE switch is pressed, C422 is discharged through D437.
- (d) Q417 is turned ON by the mute-power signal generated whenever power is turned ON or OFF, and produces the  $\overline{Kstop} = L$  pulse.

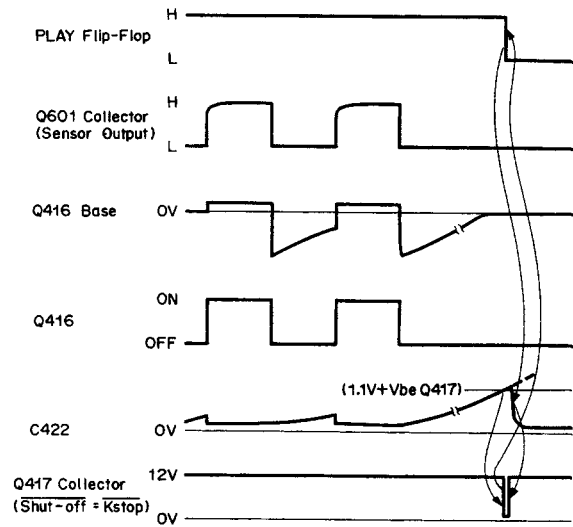

Fig. 2.3.21 Timing Chart

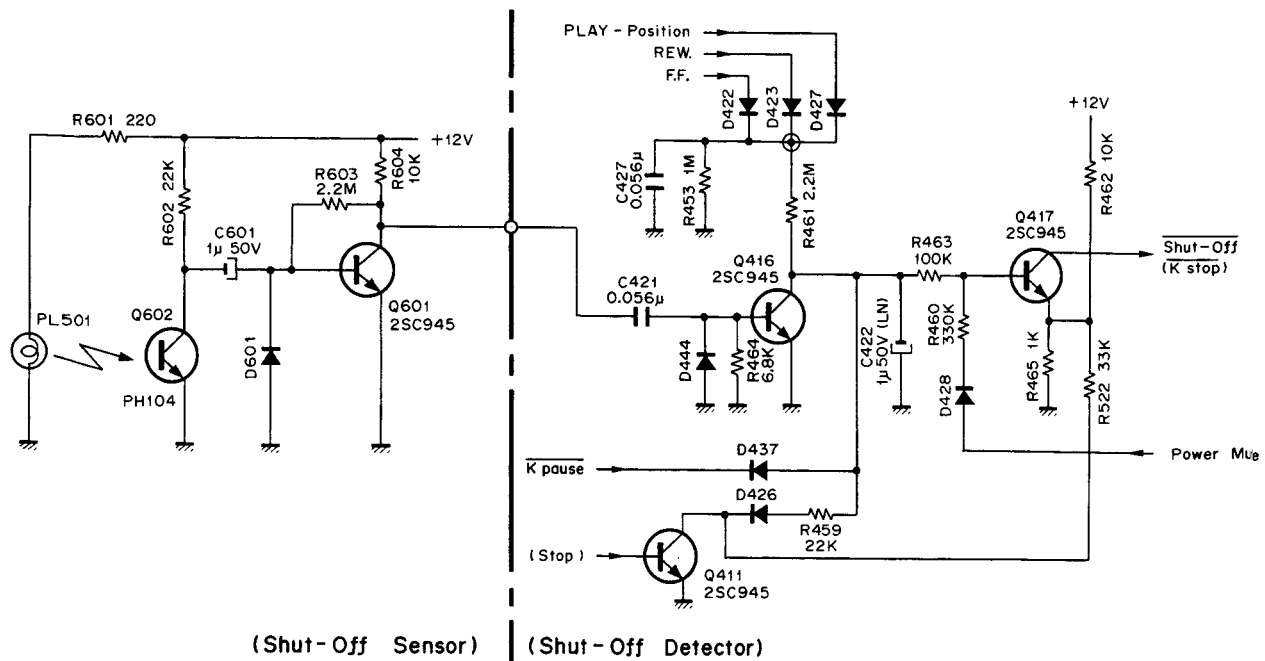

Fig. 2.3.20 Shut-OFF Sensor and Detector Circuit

**2.3.3. Control Motor Drive Circuit**

Refer to Fig. 2.3.22 circuit diagram and Fig. 2.3.23 timing chart for the series control switch operation. The control motor is turned by varying amounts, according to which control switch is set. This motor is connected to the mechanism control cam, and the mechanism of the N-580 is set to the mode indicated by this cam. The motor is driven by the differential amplifier (IC405) and drivers Q431 and Q432. When the motor has stopped, the voltage at the sliding contact of the cam control variable resistor moving synchronously with the motor (control voltage) is balanced with the reference voltage corresponding to each mode, and the input difference of the differential amplifier is zero. When a new mode is demanded, a different reference voltage breaks the balance at the differential amplifier, and the motor operates.

The motor drives the cam control variable resistor and changes the control voltage. When the control voltage is changed and the input difference of the differential amplifier becomes zero, the motor stops.

The following table shows the position of the cam and the voltage at the sliding contact of the cam control variable resistor:

Position on Cam	Voltage at Sliding Contact of Cam Control Volume
Stop	3.0 V
Rec	4.1 V
FF/REW	1.3 V
Pause	-2.8 V
Play	-5.4 V
Cue	-0.4 V

State of transistors in each mode:

STOP: Q427, Q428, Q429, Q430 OFF

PLAY: Q429 ON

FF/REW: Q428, Q430 ON

REC: Q427, Q430 ON (in the form of pulse)

PAUSE: Q429 ON

CUE: Q429, Q430 ON

**RECORD mode**

When RECORD switch and PLAY switch are pressed, Q427 pulses ON and OFF through C426, and the cam moves to the RECORD position. Then cam moves to the PLAY position and stays there, thus the mechanism is set to the RECORD mode.

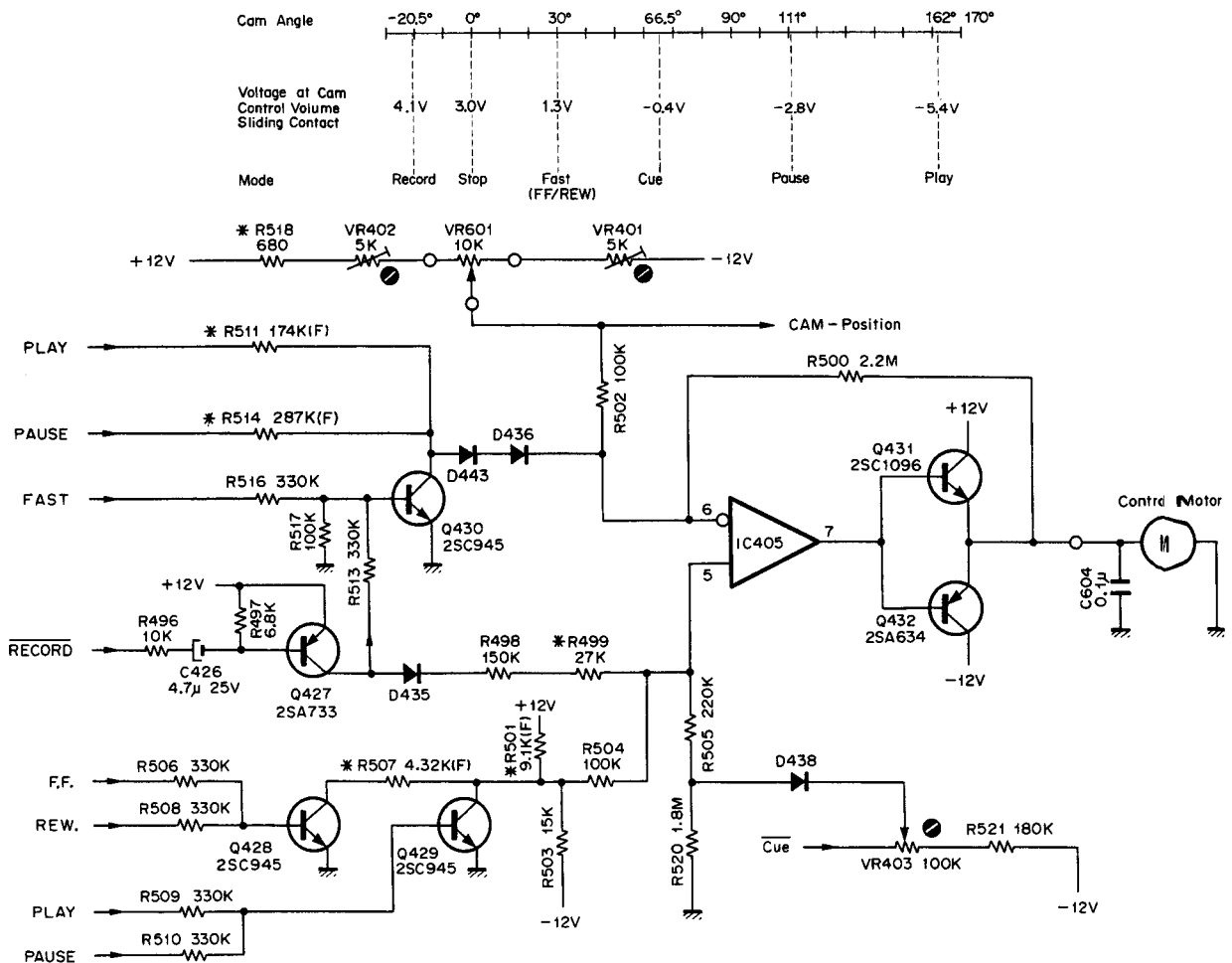

Fig. 2.3.22 Control Motor Drive Circuit

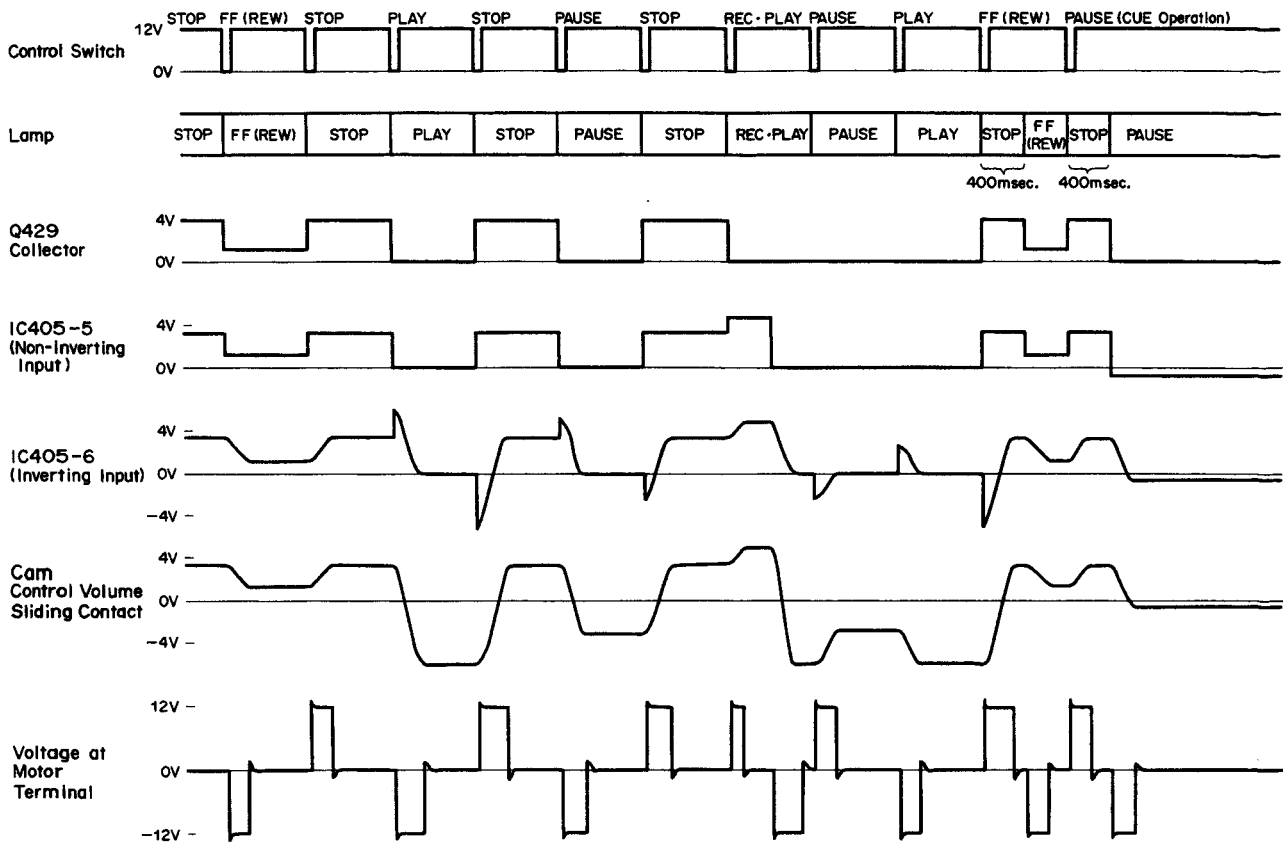

Fig. 2.3.23 Timing Chart

**2.3.4. Capstan Motor Governor**

This is a governor employing a PLL (phase-locked loop) IC, and drives the capstan motor at a constant speed when the power switch is turned ON.

**2.3.5. Reel Motor Governor**

Refer to Fig. 2.3.24 circuit diagram and Fig. 2.3.25 timing chart.

This is a governor controlling the reel motor speed and it consists of a differential amplifier, IC405, and motor drivers, Q419 and Q420, etc. The speed of the motor varies as follows:

**(1) PLAY**

Q418 is ON and IC405-2 (inverting input) is supplied with a positive voltage, and Q420 is conducted. The motor is kept running at a constant speed by the governor.

**(2) FF or REW**

A positive voltage is supplied to IC405-2 in the FF mode, when Q420 is saturated, and in the REW mode, to IC405-3 (non-inverting input), when Q419 is saturated. Therefore, the governor function does not operate and the motor turns forward or in reverse, depending on whether is supplied with an approximately -12 V or +12 V voltage.

**(3) PAUSE switch pressed during FF or REW (i.e., CUE)**

Q413 is turned ON and the input voltage to IC405 is decreased, and the motor speed is reduced to approx. 1/3 of that for FF or REW. The motor is kept running at a constant speed by the governor.

**(4) FF or REW switch kept further pressed in state (3)**  
 Since R477 is grounded through D431 or D432, the input voltage to IC405 is further decreased, and the motor speed is reduced to approx. 3/5 of that for CUE (approx. 1/5 of that for FF or REW).

The motor is kept running at a constant speed by the governor.

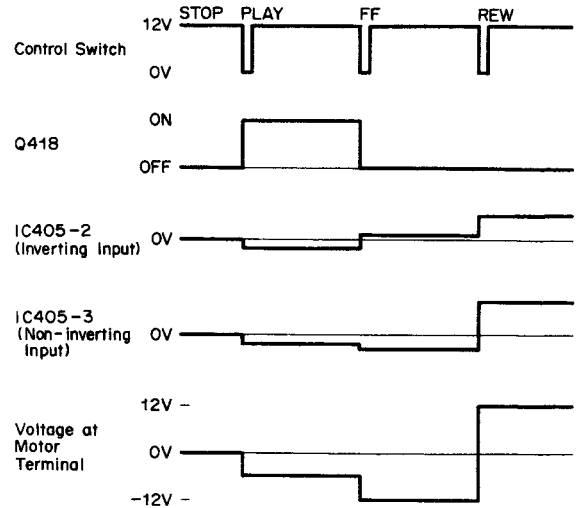

Fig. 2.3.25 Timing Chart

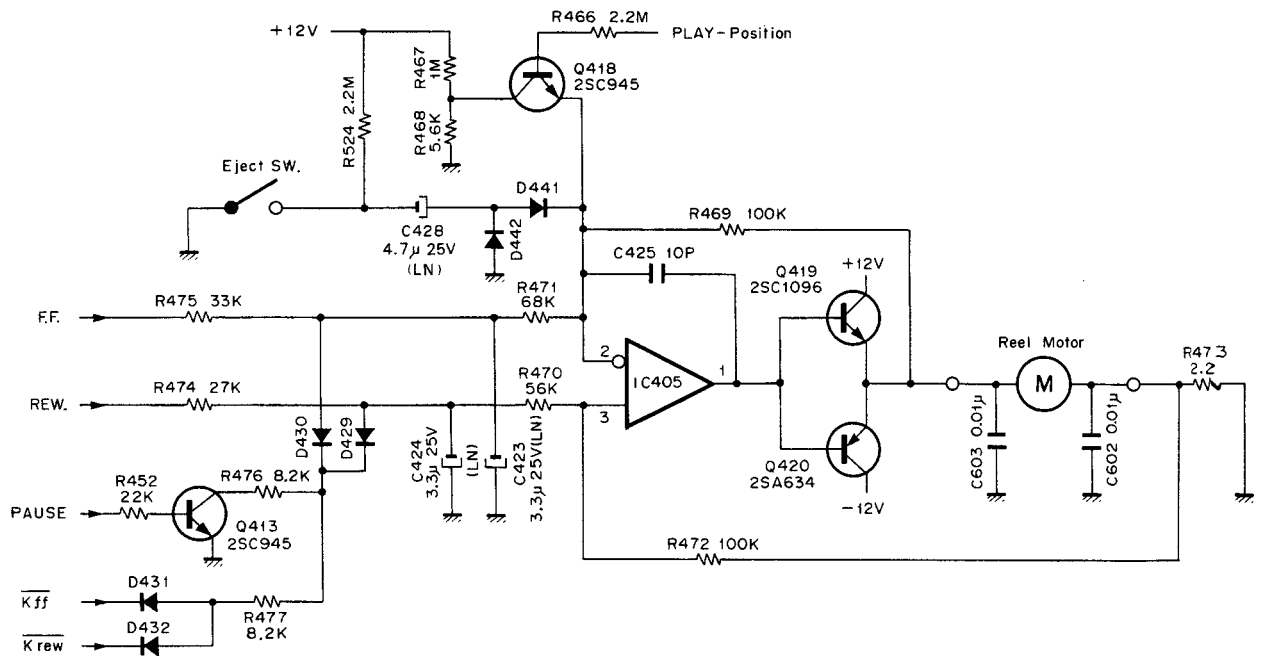

Fig. 2.3.24 Reel Motor Drive Circuit



**2.4. Remote Control Unit RM-580 (Optional)**

**2.4.1. Introduction**

The RM-580 is a remote controller for the N-582 consisting of a transmitter and a receiver. The transmitter transmits infrared control information which is received by a photosensitive diode in the receiver. The information is amplified and transmitted to the N-582 in order to control the tuning, volume, power supply and the auto-tuning of the N-582. See Fig. 2.4.1.

The control information is in the form of pulses with a frequency of approx. 22 kHz, transmitted with infrared rays.

Each unit of information consists of 7 bit and is transmitted in 10.5 ms. The first of the 7 bit is the start bit, the others being information bit. There is a time interval of 164 ms between each 7-bit unit of information and the next. See Fig. 2.4.2.

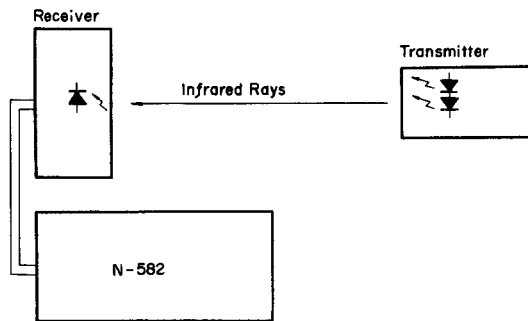

Fig. 2.4.1 RM-580 Connecting Diagram

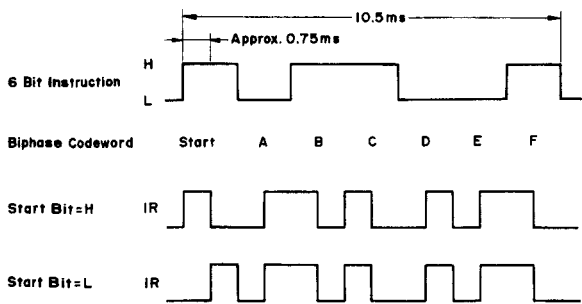

Fig. 2.4.2 Information Unit

**2.4.2. Transmitter**

The transmitter consists of a matrix key having various operation switches, a system IC for transmission, and an LED driving unit. See Fig. 2.4.3.

**(1) Matrix key**

The matrix key consists of six microswitches and six transistors: play, stop, rewind, f.f., record and pause.

**(2) System IC for transmission**

The system IC for transmission consists of IC901, the turn-ON transistor Q908, and an additional clock generator circuit.

Terminal No. 1 is connected to a positive power source and Terminal No. 6 is grounded through Q908. Since a battery is used in the RM-580 it is designed so that the power is consumed only when the matrix key is depressed and the information is transmitted.

When one of 1 to 8 and one of a to d of the keyboard scanning section of IC901 are shortcircuited, the turn-ON control section within the IC causes the voltage level at Terminal 7 of IC901 to become H. Then, Q908 is turned ON. Terminal 6 of IC901 is grounded, and the information is given from Terminal 8 through the output section. Terminals 2 to 5 correspond to a to d, and Terminals 9 to 16 correspond to 1 to 8 of the keyboard scanning section. If 1 and a of the keyboard scanning section are shortcircuited, a unit of information is generated, and if 1 and b are shortcircuited, another unit of information is generated. Thus, 32 kinds of information can be obtained from Terminal 8 through the output section. The external circuit of the clock generator used to make the pulses for information transmission is connected to Terminals 17 and 18 of IC901. The frequency is determined by the adjustment of L901.

**(3) LED driver**

The LED driver consists of Q909 and Q910 connected to Terminal 8 of IC901, and photodiodes D907 and D908. It converts the output information into infrared signals having considerable power.

The signal from Terminal 8 of IC901 becomes the base current of Q909 whose collector current is the base current of Q910 and the collector current from Q910 flowing to LED's D907 and D908 acts to transmit the information. D904, D905, D906, R925 and R926 compose a protective circuit to restrict the current to the LED's.

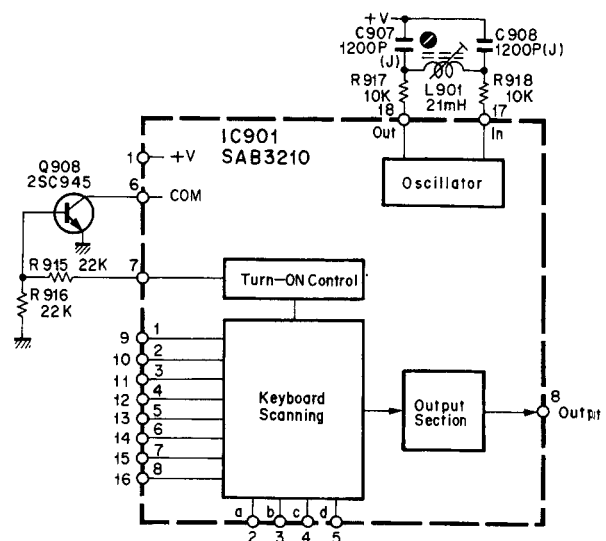

Fig. 2.4.3 Transmission IC System Diagram

**2.4.3. Receiver**

The receiver consists of a signal input, a signal amplifier, a system IC for reception, an instantaneous system IC power-disconnecting switch, a buffer amplifier, and an information processor.

**(1) Signal input**

The signal input consists of a photodiode D001, a transistor Q001 and a parallel resonance circuit.

The infrared signal radiated from the transmitter is received by the photodiode D001 and converted into a current. The current is amplified in the parallel resonance circuit consisting of C001, L001 and R001, and is further amplified by Q001.

The parallel resonance circuit is the most important part for remote control, and determines the distance at which remote operation is possible. This distance can be varied greatly by adjusting L002.

**(2) Signal amplifier**

The signal amplifier consists of IC004 and the surrounding circuits. IC004 is a specific frequency amplifier, operating at the information propagation frequency of approx. 22 kHz with an amplification of about 100 dB. This frequency is determined by R004, R005, R006, C004, C005 and C006.

**(3) System IC for reception**

The system IC for reception is IC003 shown in Fig. 2.4.4. Terminal 1 of IC003 is supplied with a positive power source and Terminal 17 is grounded. IC003 has a built-in clock-generator. An additional circuit is connected to Terminals 2 and 3 in order to make a frequency identical to that of the transmitter. The frequency can be adjusted by L002. The information signal from the transmitter is amplified by the signal amplifier and input at Terminal 15 of IC003. It is processed by a read-in register, and an output corresponding to the input is produced through program portion. Since the program portion has 4 kinds of output (A, B, C and D), 16 ( $2^4 = 16$ ) kinds of output

are produced. Terminal 8 of IC003 is called the PC terminal and is H only when an information signal is input.

**(4) Instantaneous power-disconnecting switch function**

See Fig. 2.4.5 timing chart.

The instantaneous power-disconnecting switch function for the system IC for reception consists of Q002, Q003, IC001-1,2,3, -4,5,6 and their peripheral circuit IC003 maintains its state when an information signal is output from the program portion, until the next unit of information is input. However, since the maintenance of this state affects the functioning of N-582, the information stored in the program portion must be cleared when the remote control button is released, and it is for this reason that the switching function of instantaneous power-disconnecting is provided to disconnect the power supply to IC003 and to clear the memory.

When an infrared signal is input through Terminal 15 of IC003, signal as shown in the figure are produced at Terminal 8, and fed into the base of Q002, as a result Q002 is turned ON.

The output signal of Q002 is given to the base of Q003 through inverters IC001-4,5,6 and -1,2,3. Q003 controls the power supply to IC003. When Q003 is turned ON, +12 V will be supplied to IC003, but when turned OFF, +12 V will no longer be supplied.

When a unit of information is finished, Q002 will not be turned ON, as a result C012 will be kept charging.

When the voltage of C012 exceeds the threshold level of IC001-5,6 (approximately half of applied +12 V), IC001-4 will become L and IC001-3 will become H. Thisway, H level is applied to the base of Q303 through C013, as a result Q003 will be turned OFF momentarily to disconnect the power supply to IC003, so that the program stored in IC003 will become cleared.

**(5) Information processor**

The information processor of C-MOS ICs IC0018,9,10, -11,12,13, IC002-1,2,3, -4,5,6, -8,9,10, -11,12,13, Q004, Q005 and their peripheral circuits. It processes the 4-bit output signals from IC003 input as infrared information signals.

The table of information transmitted and the corresponding 4-bit signals output from IC003 is as follows:

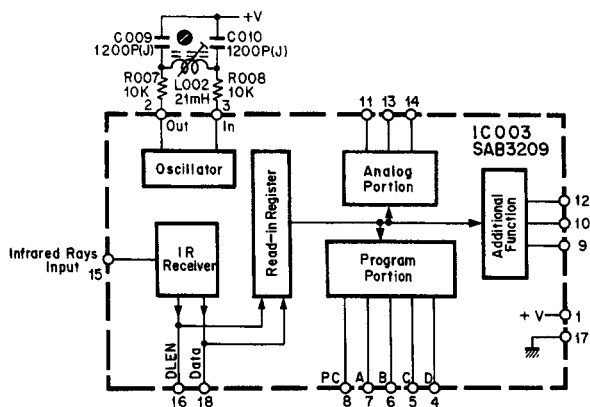

Fig. 2.4.4 Reception IC System Diagram

Information	Signal Bit			
	A(7)	B(6)	C(5)	D (4)
Play	L	H	L	H
Stop	L	H	H	L
Rewind	H	L	H	L
F.F.	H	H	L	L
Record	L	L	H	H
Pause	H	L	L	H

As shown in the above table, there are 6 kinds of information to be transmitted, and when power source and grounding are included, 8 bus lines are required. Each command will be output to Logic P.C.B. Ass'y of the N-582 as shown below:

(a) Play

When both IC002-5 (B) and -6 (D) are made H's, IC002-4 becomes L and D005 is turned ON, as a result  $\overline{\text{Play}} = \text{L}$  signal is output and Play will be activated.

(b) Stop

When both IC002-12 (B) and -13 (C) are made H's, IC002-11 becomes L and D003 is turned ON, as a result  $\overline{\text{Stop}} = \text{L}$  signal is output and Stop will be activated.

(c) Rewind

When both IC001-8 (A) and -9 (C) are made H's, IC001-10 becomes L and D007 is turned ON, as a result  $\overline{\text{Rewind}} = \text{L}$  signal is output and Rewind will be activated.

(d) F.F. (Fast Forward)

When both IC002-1 (A) and -2 (B) are made H's, IC002-3 becomes L and D006 is turned ON, as a result  $\overline{\text{F.F.}} = \text{L}$  signal is output and F.F. will be activated.

(e) Pause

When both IC002-8 (D) and -9 (A) are made H's, IC002-10 becomes L and D004 is turned ON, as a result  $\overline{\text{Pause}} = \text{L}$  signal is output and Pause will be activated.

(f) Record

When both IC001-12 (C) and -13 (D) are made H's, IC001-11 becomes L, and Q004 is turned ON, and then Q005 is turned ON with a certain time delay through C015, as a result  $\overline{\text{Record}} = \text{L}$  is output and Record will be activated.

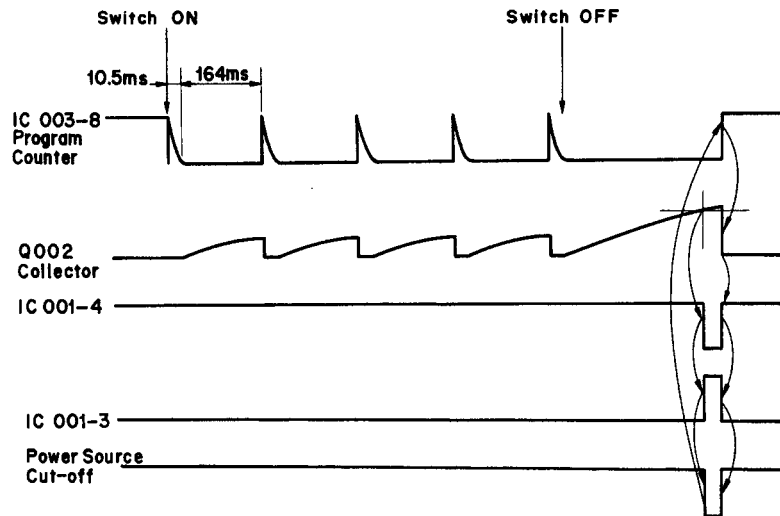

Fig. 2.4.5 Timing Chart

### 3. REMOVAL PROCEDURES

#### 3.1. Acrylic Cassette Compartment Cover

Refer to Fig. 3.1.

- (1) Push the Eject Button to open the Cassette Case Ass'y.
- (2) Pull out F01 (Acrylic Cassette Compartment Cover) upwardly.

#### 3.2. Top Cover Ass'y

Refer to Fig. 3.1.

Remove F02 and F03, then disassemble F04 (Top Cover Ass'y).

#### 3.3. Bottom Cover Ass'y

Refer to Fig. 3.1.

Remove F05, then disassemble F06 (Bottom Cover Ass'y).

#### 3.4. Front Panel Ass'y

Refer to Fig. 3.2.

- (1) Refer to Fig. 3.1. Remove Top Cover Ass'y and Bottom Cover Ass'y referring to items 3.2 and 3.3.
- (2) Remove F01 (VR Knobs) by pushing with a screwdriver or similar tools from the inside of the N-582.
- (3) Remove F02 (Switch Knobs) and F03, then disassemble F04 (Front Panel Ass'y including 2 connectors).

#### 3.5. Mechanism Ass'y

Refer to Fig. 3.2.

- (1) Remove Front Panel Ass'y referring to item 3.4.
- (2) Remove F05, then disassemble F06 (Headphone Jack Ass'y).
- (3) Remove F07, then disassemble F08 (Mechanism Ass'y including 4 connectors).

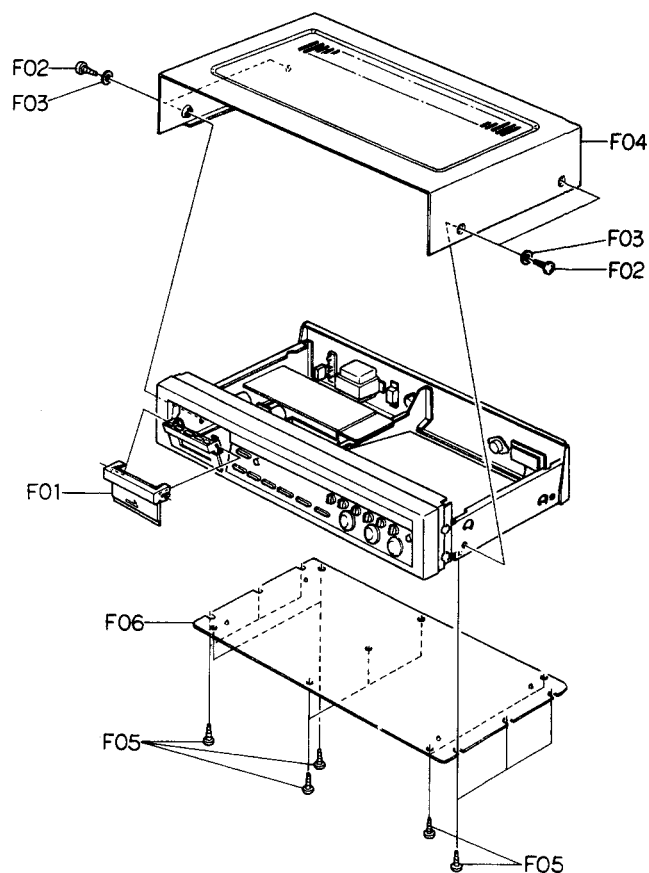

Fig. 3.1

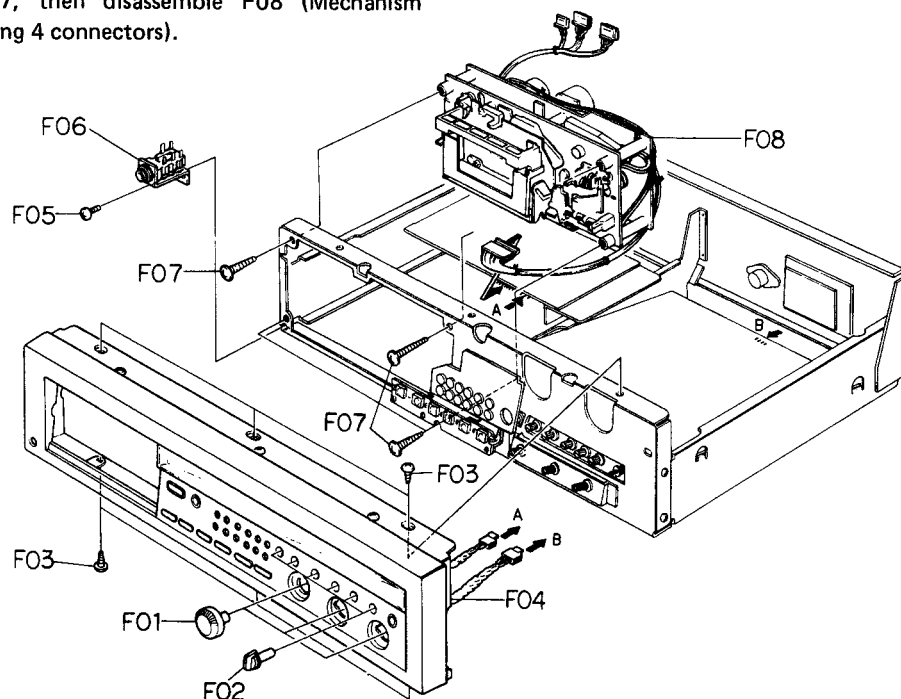

Fig. 3.2

**3.6. Main P.C.B. Ass'y**

Refer to Fig. 3.3.

- (1) Refer to Fig. 3.2. Remove Front Panel Ass'y referring to item 3.4.
- (2) Remove the flat cable, connectors and wires connected by wrapping from F04 (Main P.C.B. Ass'y).
- (3) Remove F01, F02 and F03, then disassemble F04 (Main P.C.B. Ass'y).

**3.7. Logic P.C.B. Ass'y**

Refer to Fig. 3.3.

- (1) Refer to Fig. 3.2. Remove Front Panel Ass'y referring to item 3.4.
- (2) Remove the connectors and wires connected by wrapping from F06 (Logic P.C.B. Ass'y).
- (3) Remove F05, then disassemble F06 (Logic P.C.B. Ass'y).

**3.8. Power Switch**

Refer to Fig. 3.3.

- (1) Remove Main P.C.B. Ass'y referring to item 3.6.
- (2) Remove F07 and F08, then disassemble F09 (Power Switch).

**3.9. Volume P.C.B. Ass'y**

Refer to Fig. 3.3.

- (1) Refer to Fig. 3.2. Remove Front Panel Ass'y referring to item 3.4.
- (2) Remove F10, then disassemble F11 (Volume P.C.B. Ass'y).

**3.10. Control Button Ass'y**

Refer to Fig. 3.3.

- (1) Refer to Fig. 3.2. Remove Front Panel Ass'y referring to item 3.4.
- (2) Remove F12, then disassemble F13 (Control Button Ass'y).

**3.11. Record Cal. P.C.B. Ass'y**

Refer to Fig. 3.3.

- (1) Refer to Fig. 3.2. Remove Front Panel Ass'y referring to item 3.4.
- (2) Remove F14, then disassemble F15 (Record Cal. P.C.B. Ass'y).

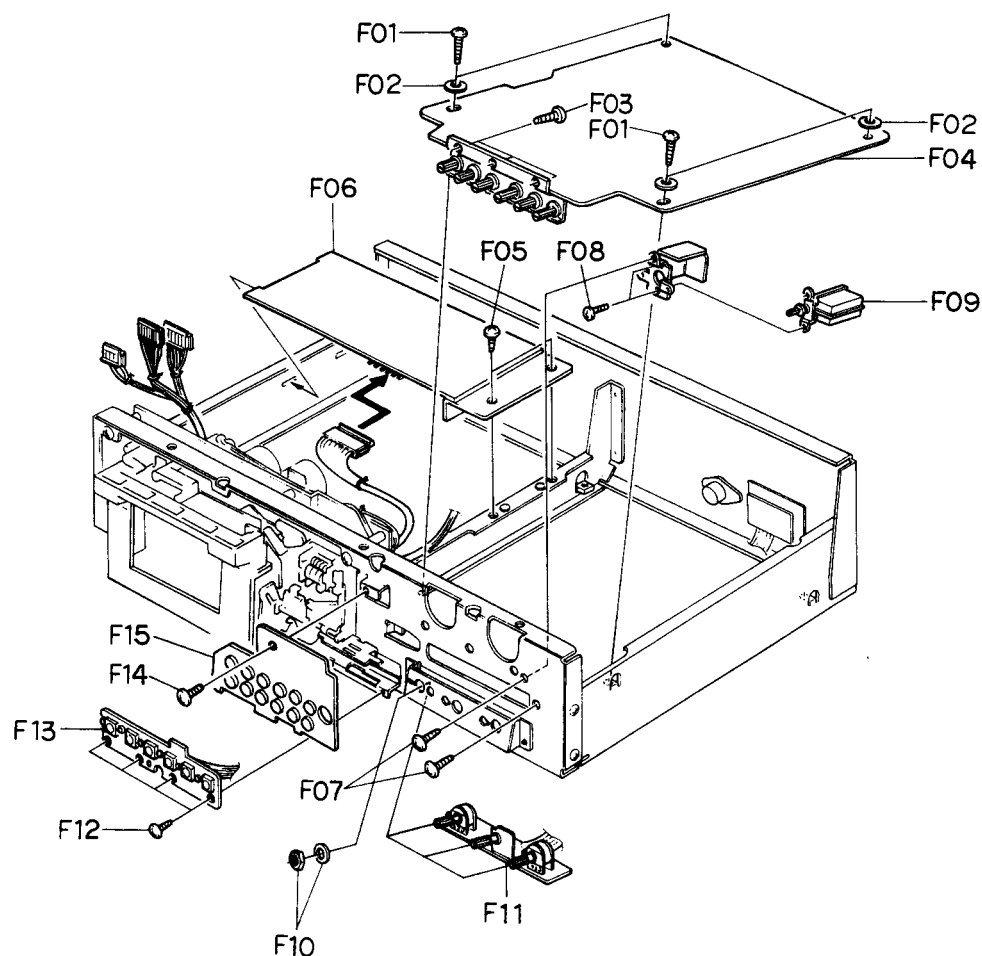

Fig. 3.3

**3.12. Meter Ass'y**

Refer to Fig. 3.4.

- (1) Refer to Fig. 3.2. Remove Front Panel Ass'y referring to item 3.4.
- (2) Remove F01 and F02, then disassemble F03 (Meter Ass'y).

**3.13. Lamp P.C.B. Ass'y**

Refer to Fig. 3.4.

- (1) Remove Meter Ass'y referring to item 3.12.
- (2) Remove F04, then disassemble F05 (Lamp House Cover Ass'y).
- (3) Remove F06, then disassemble F07 (Lamp. P.C.B. Ass'y).

**3.14. Aluminum Mirror**

Refer to Fig. 3.4.

- (1) Remove Lamp House Cover Ass'y referring to item 3.13.
- (2) Remove F08, then disassemble F09 (Aluminum Mirror).

**3.15. Rear Panel Ass'y**

Refer to Fig. 3.5.

- (1) Refer to Fig. 3.1. Remove Top Cover Ass'y and Bottom Cover Ass'y referring to items 3.2 and 3.3.
- (2) Remove F01, F02 and F03, then disassemble F04 (Rear Panel Ass'y).

**3.16. Power Transformer**

Refer to Fig. 3.5.

- (1) Refer to Fig. 3.1. Remove Top Cover Ass'y and Bottom Cover Ass'y referring to items 3.2 and 3.3.
- (2) Remove F05, F06 and F07, then disassemble F08 (Power Transformer).

**3.17. Cassette Case Ass'y**

Refer to Fig. 3.6.

- (1) Refer to Fig. 3.2. Remove Mechanism Ass'y referring to item 3.5.
- (2) Push the Eject Button to open the Cassette Case Ass'y.
- (3) Remove F01, then disassemble the piston of the Air Damper Ass'y.
- (4) Remove F02 and F03, then disassemble F04 (Cassette Case Ass'y).

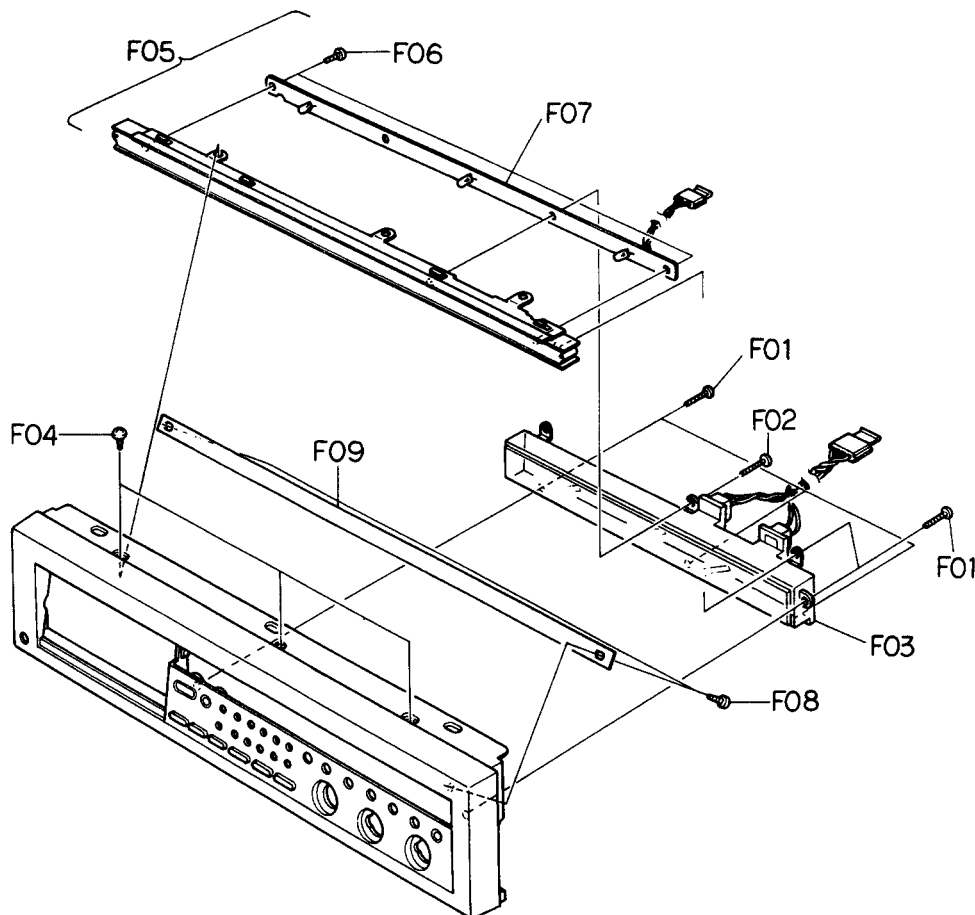

Fig. 3.4

**3.18. Cover Plate**

Refer to Fig. 3.6.

- (1) Refer to Fig. 3.2. Remove Front Panel Ass'y referring to item 3.4.
- (2) Push the Eject Button to open the Cassette Case Ass'y.
- (3) Remove F05, then disassemble F06 (Cover Plate).

**3.19. Tape Counter Ass'y**

Refer to Fig. 3.6.

- (1) Refer to Fig. 3.2. Remove Front Panel Ass'y referring to item 3.4.
- (2) Remove F07, then disassemble F08 (Tape Counter Ass'y).

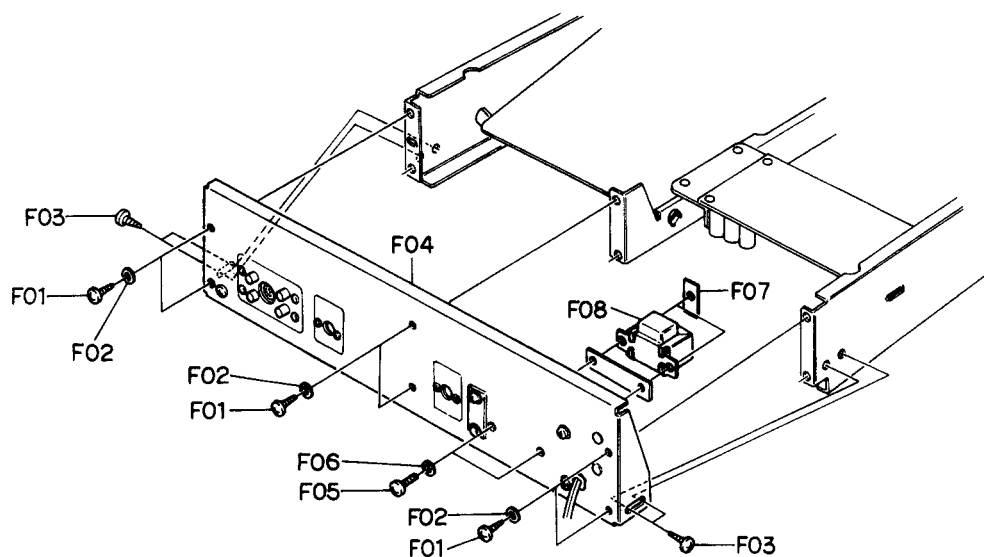

Fig. 3.5

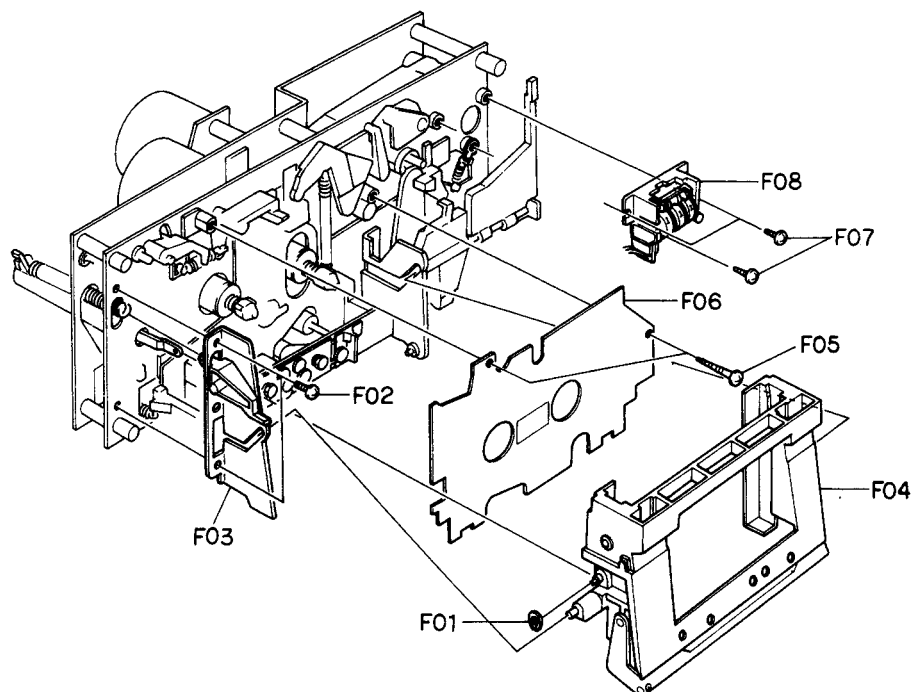

Fig. 3.6

### 3.20. Capstan Motor Ass'y and Flywheel Ass'y

Refer to Fig. 3.7.

- (1) Refer to Fig. 3.2. Remove Mechanism Ass'y referring to item 3.5.
- (2) Remove F01 and F02, then disassemble F03 (Flywheel Holder Ass'y) and F06 (Capstan Belt).
- (3) Remove F04, then disassemble F05 (Capstan Motor Ass'y).
- (4) Remove F07 (Supply Flywheel Ass'y), then disassemble F08 (Take-up Flywheel Ass'y).
- (5) After removing both Flywheel Assemblies, disassemble F09 (Thrust Washer 3.1 mm), F10 (Thrust Washer 2.6 mm), F11 (Flange Thrust Caps) and F12 (Flywheel Thrust Springs).

### 3.21. Sub Mechanism Chassis Ass'y

Refer to Fig. 3.8.

- (1) Refer to Fig. 3.2. Remove Mechanism Ass'y referring to item 3.5.
- (2) Remove Flywheel Holder Ass'y and both Flywheel Assemblies referring to above item 3.20.
- (3) Remove F01 and F02, then disassemble F03 (Sub Mechanism Chassis Ass'y).

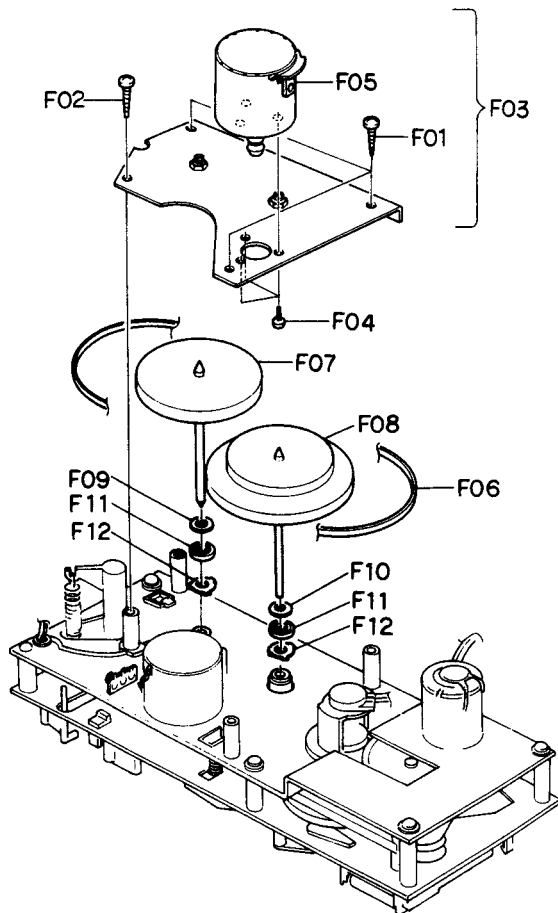

Fig. 3.7

### 3.22. Control Motor Ass'y

Refer to Fig. 3.8.

- (1) Remove Sub Mechanism Chassis Ass'y referring to item 3.21.
- (2) Remove F04, then disassemble F05 (Control Motor Ass'y).

### 3.23. Reel Motor Ass'y

Refer to Fig. 3.8.

- (1) Remove Sub Mechanism Chassis Ass'y referring to item 3.21.
- (2) Remove F06, then disassemble F07 (Reel Motor Ass'y).

### 3.24. Cam Control Volume

Refer to Fig. 3.8.

- (1) Remove Sub Mechanism Chassis Ass'y referring to item 3.21.
- (2) Remove F08, then disassemble F09 (Volume Coupler).
- (3) Remove F10, then disassemble F11 (Cam Control Volume).

### 3.25. Reel Hub Ass'y

Refer to Fig. 3.8.

- (1) Remove Sub Mechanism Chassis Ass'y referring to item 3.21.
- (2) Remove F12 (Reel Hub Heads).
- (3) Remove F13 (Reel Hub B Assemblies).
- (4) Remove F14 (Reel Hub Take-up Ass'y) and F15 (Reel Hub Supply Ass'y).
- (5) Remove F16 (Back Tension Felt) and F17 (Back Tension Spring) from the supply side Reel Hub Ass'y.

### 3.26. Idler Ass'y

Refer to Fig. 3.8.

- (1) Remove Sub Mechanism Chassis Ass'y referring to item 3.21.
- (2) Remove F18, then disassemble F19 (Idler Ass'y).

### 3.27. Cam Drive Gear and Cam

Refer to Fig. 3.8.

- (1) Remove Sub Mechanism Chassis Ass'y referring to item 3.21.
- (2) Remove F20, then disassemble F21 (Cam Drive Gear).
- (3) Remove F22, then disassemble F23 (Counter-Load Arm Ass'y).
- (4) Remove F24, then disassemble F25 (Cam).

### 3.28. Head Mount Base Ass'y

Refer to Fig. 3.9.

- (1) Refer to Fig. 3.6. Remove Cassette Case Ass'y referring to item 3.17.
- (2) Remove F01, then disassemble F02 (Head Mount Base Ass'y).



**3.29. Supply Pressure Roller Ass'y**

Refer to Fig. 3.9.

- (1) Remove Head Mount Base Ass'y referring to item 3.28.
- (2) Remove F03 and a washer, then disassemble F04 (Supply Pressure Roller Ass'y).

**3.30. Erase Head**

Refer to Fig. 3.9.

- (1) Remove Head Mount Base Ass'y referring to item 3.28.
- (2) Remove F05, then disassemble F06 (Erase Head).

**3.31. Take-up Pressure Roller Ass'y**

Refer to Fig. 3.9.

- (1) Remove Head Mount Base Ass'y referring to item 3.28.

- (2) Remove F07 and a washer, then F08 (Take-up Pressure Roller Ass'y).

**3.32. Playback Head Ass'y**

Refer to Fig. 3.9.

- (1) Remove Head Mount Base Ass'y referring to item 3.28.
- (2) Turn F09 by 90° by pushing it, then disassemble F10 (Playback Head Ass'y).

**3.33. Record Head Ass'y**

Refer to Fig. 3.9.

- (1) Remove Head Mount Base Ass'y referring to item 3.28.
- (2) Turn F11 by 90° by pushing it, then disassemble F12 (Record Head Ass'y).

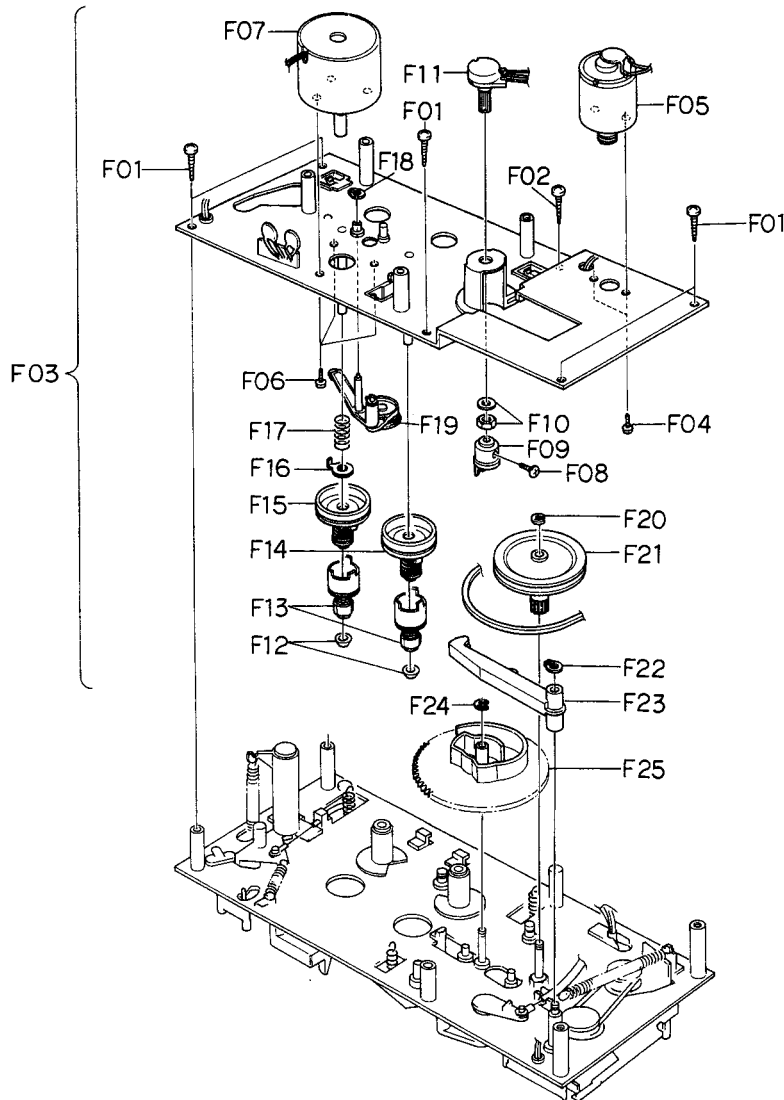

Fig. 3.8

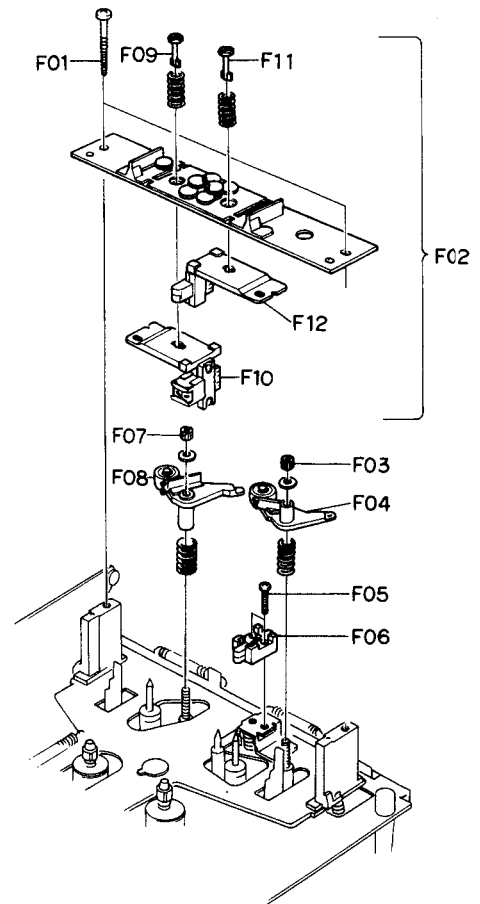

Fig. 3.9

#### 4. MEASUREMENT INSTRUMENTS

- (1) Audio Generator (20 Hz – 200 kHz)
- (2) AC Millivolt Meter (with dB measures)
- (3) Oscilloscope (DC – 5 MHz)
- (4) Distortion Meter
- (5) Speed & Wow/Flutter Meter
- (6) Frequency Counter (DC – 1 MHz)
- (7) Ohm Meter
- (8) DC Volt Meter
- (9) AC Volt Meter
- (10) Torque Gauge (DA09013A)
- (11) 15 kHz Azimuth Tape (DA09004A)
- (12) 3 kHz Speed & Wow/Flutter Tape (DA09006A)
- (13) 1 kHz Track Alignment Tape (DA09007A)
- (14) 400Hz Level Tape (DA09005A)
- (15) 20 kHz PB Frequency Response Tape (DA09001A)
- (16) 15 kHz PB Frequency Response Tape (DA09002A)
- (17) 10 kHz PB Frequency Response Tape (DA09003A)
- (18) Reference EXII Tape (DA09021A)
- (19) Reference SX Tape (DA09025A)
- (20) Tilt Check Gauge M-9039 (DA09039A)
- (21) EH Tilt Check Gauge M-9040 (DA09040A)
- (22) EH Stroke Check Gauge M-9042 (DA09042A)
- (23) Stroke Check Gauge M-9047 (DA09047A)
- (24) Record Head Mounting Gauge M-9048 (DA09048A)
- (25) Audio Analyzer T-100  
(including Distortion, Wow/Flutter, Speed, Oscillator and dB meter)

Note: (10) – (25) are the products of Nakamichi Corporation.

## 5. MECHANICAL ADJUSTMENTS

### 5.1. Mechanism Control Cam Adjustment

Before adjustment, disassemble the Front Panel Ass'y then remove the Cover Plate, referring to items 3.4 and 3.18.

#### (1) Offset Adjustment of Control Motor Driver

(a) Refer to Figs. 5.1 and 5.2.

Adjust VR402 and VR401 on the Logic P.C.B. to locate approximately at the middle of the variable range. Then turn ON the Power Switch.

VR402 (for Cam position stop)

VR401 (for Cam position play)

(b) Press the Stop Switch to set the N-582 in stop mode. Adjust VR402 (for stop) so that the "S" mark on the Cam corresponds to the pointer on the mechanism chassis.

(c) Press the Play Switch to set the N-582 in playback mode.

(Cam will rotate, and the position marked with "PY" comes to the pointer.)

Adjust VR401 (for play) so that the "PY" mark on the Cam corresponds to the pointer.

(d) Repeat above (b) and (c) 2 – 3 times so that the "S" and "PY" marks on the cam correspond to pointer accurately in stop and playback modes respectively. (This adjustment is required because the position adjusted by one volume will be slightly changed when the other volume is adjusted.)

(e) Set the N-582 in FF, pause, record, or cue mode by pressing each switch (press FF and Pause Switches to set the N-582 in cue mode) and check to insure that the pointer is in a range of "F", "PS", "R", or "CU" mark respectively.

(f) If out of the range, precise adjustment for each position according to "(2) Offset Fine Adjustment of Control Motor Driver" will be required.

#### (2) Offset Fine Adjustment of Control Motor Driver

Adjust only if a satisfactory result is not obtained in "(1) Offset Adjustment of Control Motor Driver".

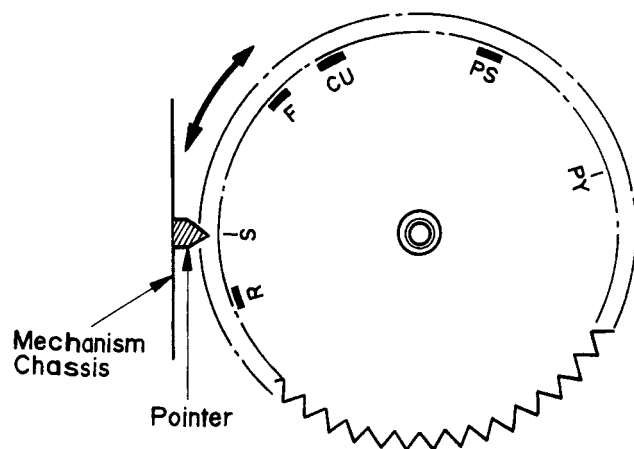

Fig. 5.1

This adjustment is made by changing the value of the fixed resistors on the Logic P.C.B. Voltages below shown are typical value.

#### (a) Observation Point of Reference Voltage

Observe the each voltage at the sliding contact of the Cam Control Volume VR601 (10 k $\Omega$ ) in stop, fast (FF or REW), pause, and playback mode.

Note: When Record and Play Switches are pressed to set N-582 in record mode, the Cam is first set to the record position in a short period of time then stays at the play position.

Therefore, to keep the Cam at the record position, following procedure is required:

Short the both leads of capacitor C426 (4.7  $\mu$ F 25 V) on the Logic P.C.B. with a jumper wire, then press the Record and Play Switches.

#### (b) Reference Voltage

Reference voltage at the sliding contact of VR601 (Cam Control Volume) in each mode is as follows:

Mode	Reference Voltage (Typical Value)
Record	4.1 V
Stop	3.0 V
Fast (FF/REW)	1.3 V
Pause	-2.8 V
Playback	-5.4 V

The typical values for Record, Stop, and Playback are grouped together with a bracket and labeled as  $1.1 \text{ V } +0.4 \text{ V}$  to  $-0.2 \text{ V}$  and  $1.7 \text{ V } \pm 0.25 \text{ V}$  respectively. The typical values for Pause and Playback are grouped together with a bracket and labeled as  $2.6 \text{ V } \pm 0.4 \text{ V}$ .

#### (c) Resistors for Adjustment

Mode	Ref. No.	Typical Value
Stop	R501	9.1 k $\Omega$ (F)
Fast (FF/REW)	R507	4.32 k $\Omega$ (F)
Pause	R514	287 k $\Omega$ (F)
Playback	R511	174 k $\Omega$ (F)
Record	R499	27 k $\Omega$

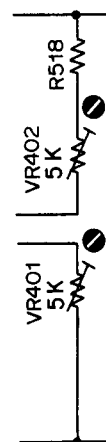

Fig. 5.2

**(d) Adjustment Procedures**

- 1) Press the Stop Switch to set the N-582 in stop mode. Adjust the value of R501 to obtain 3.0 V ( $\pm 0.6$  V) at the sliding contact of VR601.

Note: When R501 is adjusted, the reference voltage in fast (FF or REW) mode is changed. Therefore, re-check of the reference voltage in fast (FF or REW) mode is required.

If the reference voltage is out of the range, re-adjustment of R507 according to next step 2) is necessary.

- 2) Set the N-582 in FF mode, then adjust the value of R507 so that the voltage of VR601 will become lower by 1.7 V ( $\pm 0.25$  V) than in stop mode.
- 3) Press the Pause Switch to set the N-582 in pause mode. Adjust the value of R514 to obtain  $-2.8$  V ( $+0.4$ ,  $-0.15$  V) at the sliding contact of VR601.
- 4) Set the N-582 in playback mode, then adjust the value of R511 so that the voltage of VR601 will become lower by 2.6 V ( $\pm 0.4$  V) than in pause mode.
- 5) Short the both leads of capacitor C426 with a jumper wire.

Set the N-582 in record mode, then adjust the value of R499 so that the voltage of VR601 will become higher by 1.1 V ( $+0.4$ ,  $-0.2$  V) than in stop mode.

Note: Remove the short of C426 after completion of adjustment.

**(3) Cam Timing Adjustment**

- (a) Remove the wires from the Control Motor Terminals to set the motor open.
- (b) Without loading a cassette tape and with pressing the Record Protecting Switch with your fingers, press the Record and Play Switches to set the N-582 in record mode.
  - (c) Turn the Cam and bring the "PY" mark toward the pointer by hand. Reel Motor will rotate before the "PY" mark reaches the pointer. Adjust the value of R488 so that the voltage at sliding contact of VR601 becomes  $-3.6$  V ( $\pm 0.3$  V) when Reel Motor starts rotation.
- (d) Observe the mute signal at the Q424 collector. Turn the Cam referring to above step (c) and check to insure that the voltage at the sliding contact of VR601 is  $-3.8$  V ( $\pm 0.3$  V) when mute is released (mute signal changes from H to L). (This voltage is determined by the adjustment of R488 in above step (c).)
- (e) Observe the  $\overline{\text{Rec}}$  signal at the Q421 collector. Turn the Cam referring to above step (c) and adjust the value of R480 to obtain  $-2.1$  V ( $\pm 0.4$  V) at the sliding contact of VR601 when  $\overline{\text{Rec}}$  signal changes from H to L (bias oscillation will begin).

- (f) Upon completion of above adjustment, re-connect wires to the motor terminals.

**5.2. Tape Speed Adjustment**

- (1) Remove the Top Cover.
- (2) Connect a Frequency Counter to the Output Jack.
- (3) Load a 3 kHz Speed Wow/Flutter Tape (DA09006A) and play it back.
- (4) Referring to Fig. 5.3, adjust the Tape Speed Adjustment Volume (VR501) incorporated in the Capstan Motor to obtain 3,000 Hz on the Frequency counter.

CCW: Motor drives slowly.

CW: Motor drives fast.

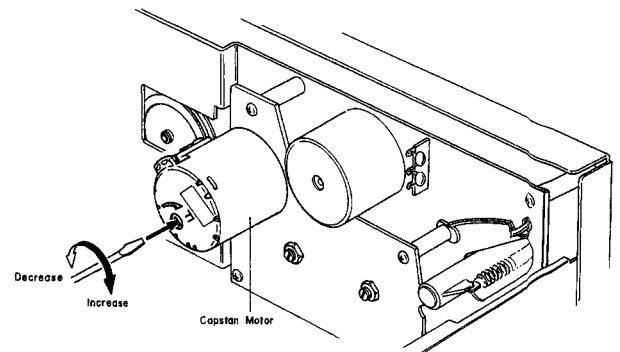

Fig. 5.3

**5.3. Record Head and Playback Head Tilt Adjustment**

Note: On items 5.3 – 5.8, please refer to Fig. 5.4 flow chart.

Refer to Figs. 5.5 and 5.6.

- (1) Load a Tilt Check Gauge M-9039 (DA09039A) in the N-582.
- (2) Clip the grounding terminal of the Tilt Check Gauge with one end of the cord with clip, and the other end to the chassis of the N-582.
- (3) Remove both of the Height Gears.
- (4) Set the N-582 in play mode. Check to insure whether the Beacons Playback Head "Upper" or "Lower" and Record Head "Upper" or "Lower" are illuminating. In order not to give damages onto the head surfaces, push both of slide knobs of the Gauge to the direction of arrow marks, then return it to the original place to be in contact with record head and playback head surfaces after play mode is securely locked.
- (5) Check to insure freedom from contact between the Gauge and pad lifter.
- (6) Beacon Playback Head "Lower" will light on when height adjustment screw (P) turned clockwise but Playback Head "Upper" when counterclockwise. Adjust so that both "Upper" and "Lower" will light on even when you move the slide knob to the direction of an arrow mark and then return it to the original place.

- (7) Same procedures will apply to the Beacons Record Head "Upper" and "Lower", except for the height adjustment screw (R).
- (8) Set the N-582 in stop mode and fit both of the ser-

rated height gears. Then set the N-582 again in play mode and insure all of the 4 Beacons are illuminating. If not, (3) through (7) will have to be repeated till satisfactory results are obtained.

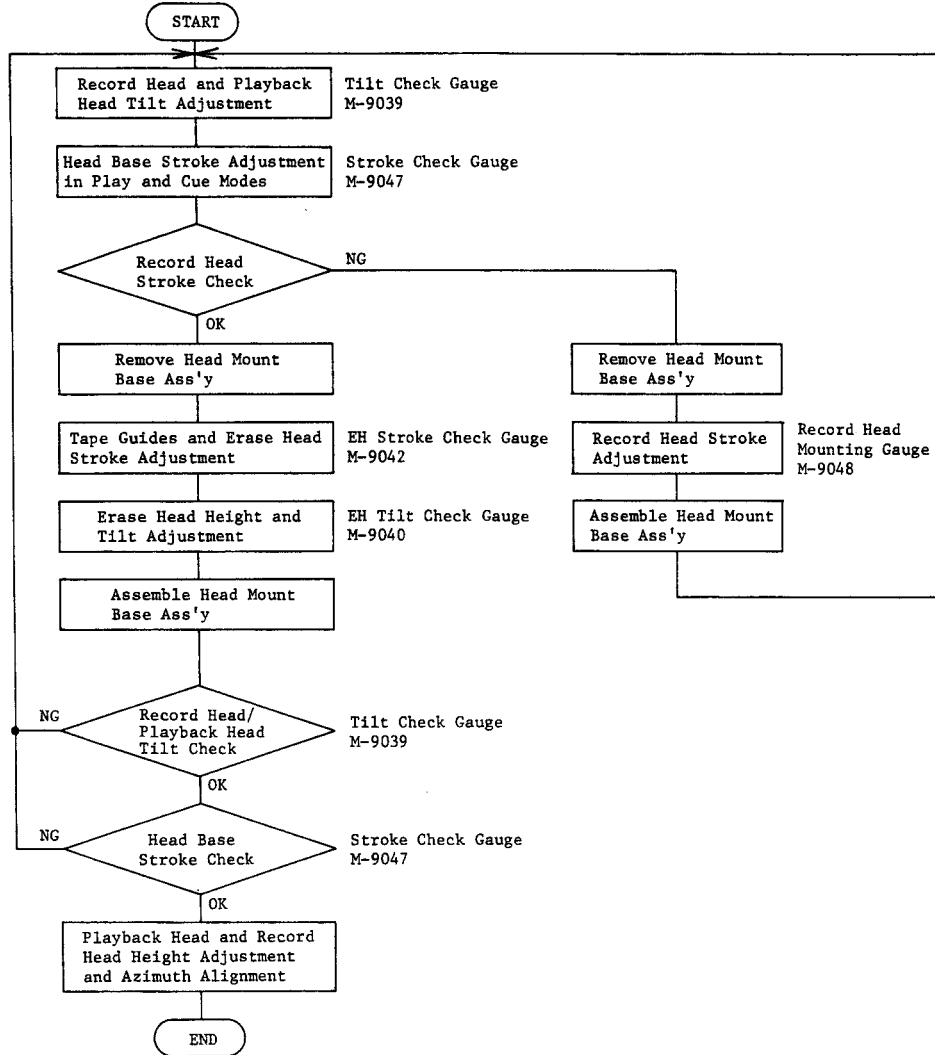

Fig. 5.4 Adjustment Flow Chart

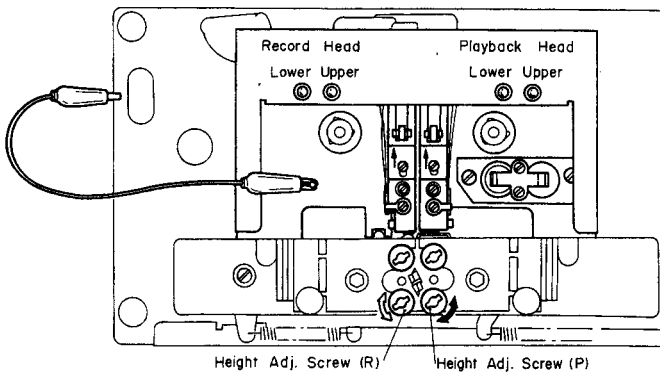

Fig. 5.5

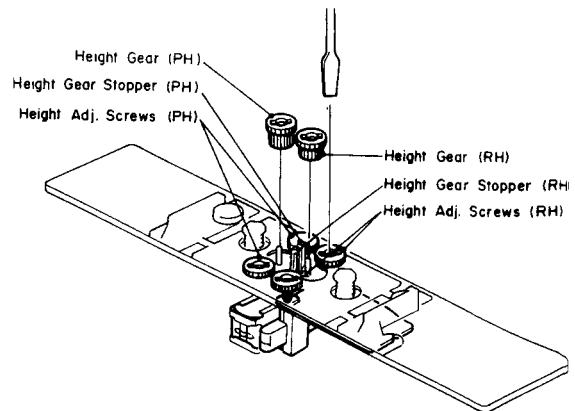

Fig. 5.6

#### 5.4. Head Base Stroke Adjustment in Play and Cue Modes

Note: Before you conduct this adjustment, adjust with a "Tilt Check Gauge" to insure freedom from tilt on the playback head and record head.

##### (1) Head Base Stroke Adjustment in Play Mode

Refer to Fig. 5.7.

- (a) Load a Stroke Check Gauge M-9047 (DA09047A) in the N-582.
- (b) Move Record Head Indicator and Playback Head Indicator to the direction of arrow mark "A" with your finger tip and then set the N-582 in play mode. Then slowly release the Indicators and insure whether each of the Indicators is in contact with record and playback heads.
- (c) Check to insure whether the "P" pointer on the Playback Head Indicator locates between the 2 lines on the Indicator Plate.
- (d) If the playback head stroke is noted to be misaligned, adjustment can be made by moving the stroke adjuster assembled in the head base assembly (either forwardly or backwardly).
- (e) Check to insure whether the "P" pointer on the Playback Head Indicator locates between the 2 lines on the Record Head Indicator, thus check can be made on record head stroke.

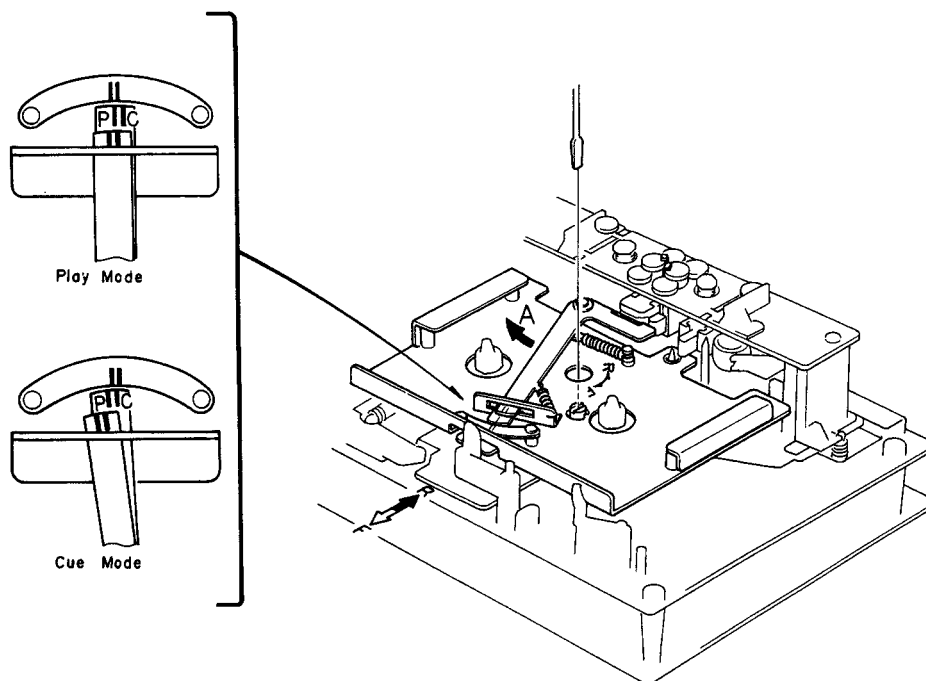

Fig. 5.7

- (f) If the record head stroke is noted to be misaligned, adjustment can be made with a Record Head Mounting Gauge M-9048 (DA09048A).

##### (2) Head Base Stroke Adjustment in Cue Mode

Refer to Fig. 5.8.

- (a) Load a Stroke Check Gauge M-9047 (DA09047A) in the N-582.
- (b) Move Record Head Indicator and Playback Head Indicator to the direction of arrow mark "A" with your finger tip and then set the N-582 in cue mode (F.F. and Pause). Then slowly release the Indicators and insure whether each of the Indicators is in contact with record and playback heads.
- (c) Check to insure whether the "C" pointer on the Playback Head Indicator locates between the 2 lines on the Indicator Plate.
- (d) If the playback head stroke is noted to be misaligned, adjust VR403 of the Logic P.C.B. Ass'y till satisfactory results are obtained.
- (e) After completion of the Head Base Stroke Adjustment, check to insure accuracy of the Head Base Stroke Adjustment in play mode. If the above are inaccurate, items (1) and (2) will have to be repeated till satisfactory results are obtained.

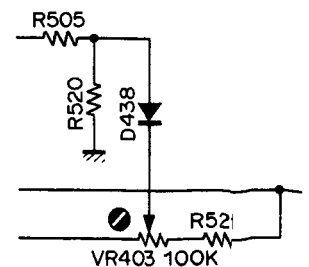

Fig. 5.8

### 5.5. Tape Guides Adjustment and Erase Head Stroke Adjustment

Remove Head Mount Base Ass'y referring to item 3.28. Refer to Figs. 5.9 and 5.10.

#### (1) Supply Tape Guide Height Adjustment

- Load an EH Stroke Check Gauge M-9042 (DA09042A) in the N-582.
- Set the N-582 in play mode.
- Slide the Supply Tape Guide Check Bar down against the supply tape guide, thus check can be made on supply tape guide height.
- If the supply tape guide is misaligned, the Supply Tape Guide Check Bar will not come into the supply tape guide. If such is noted, turn to adjust the height adjustment nut A till the Supply Tape Guide Check Bar is accepted by the supply tape guide.
- If the above are insured, set the N-582 in pause mode, then in play mode to see whether adjustments are appropriately made. If not, (b) through (e) will have to be repeated till satisfactory results are obtained.

#### (2) Take-up Tape Guide Height Adjustment

- Load an EH Stroke Check Gauge M-9042 (DA09042A) in the N-582.

- Set the N-582 in play mode.
- Slide the Take-up Tape Guide Check Bar down against the take-up tape guide, thus check can be made on take-up tape guide height.
- If the take-up tape guide is misaligned, the Take-up Tape Guide Check Bar will not come into the take-up tape guide. If such is noted, turn to adjust the height adjustment nut B till the Take-up Tape Guide Check Bar is accepted by the take-up tape guide.
- If the above are insured, set the N-582 in pause mode, then in play mode to see whether adjustments are appropriately made. If not, (b) through (e) will have to be repeated till satisfactory results are obtained.

#### (3) Erase Head Stroke Adjustment

- Load an EH Stroke Check Gauge M-9042 (DA09042A) in the N-582.
- Set the N-582 in play mode, thus check can be made on erase head stroke through the EH Stroke Indicator.
- Check to insure whether the erase head surface is aligned with red line on the EH Stroke Indicator. If not, adjust the erase head stroke by loosening 2 screws that assembled erase head and erase head plate.
- After completion of adjustment, 2 pcs. of screws shall be locked with lock tight paint.

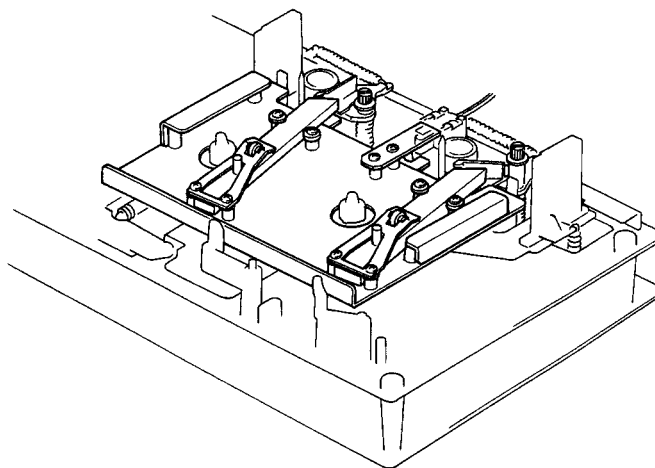

Fig. 5.9

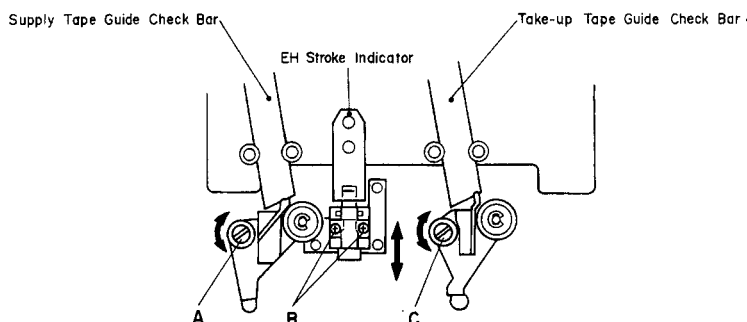

Fig. 5.10

### 5.6. Erase Head Height and Tilt Adjustment

Refer to Figs. 5.11 and 5.12.

- (1) Remove Head Mount Base Ass'y referring to item 3.28.
- (2) Load an EH Tilt Check Gauge M-9040 (DA09040A) in the N-582.
- (3) Set the N-582 in stop mode.
- (4) Check to insure whether one of the 3 Beacons is illuminating. Look down the mirror as shown by an arrow mark and slowly turn the Screw "Height" counterclockwise (or clockwise) so that the two horizontal lines of the mirror will become superposed on the line (in different color) of the erase head, and check to insure whether Beacon "1" is illuminating.
- (5) Turn Screw "Tilt" counterclockwise (or clockwise) to light on Beacon "2". Excessive turning will cause the Beacon "1" to light off. Adjustments of Screw

"Tilt" will therefore be conducted till both of the Beacon "1" and "2" illuminate.

- (6) Turn Screw "Azimuth" counterclockwise (or clockwise) to light on Beacon "3". Excessive turning will cause either Beacon "1" or "2" to light off, and therefore adjust with Screw "Azimuth" until all of the 3 Beacons, "1", "2" and "3" illuminate.
- (7) Check to insure whether the horizontal line on the mirror corresponds to that on the erase head. If not, (4) through (7) will have to be repeated till satisfactory results are obtained.
- (8) After completion of adjustment, 3 pcs. of screws shall be locked with lock tight paint.

Note: Before use of this gauge, check to insure freedom from dust or dirt, or overflow in the groove of the erase head surface.

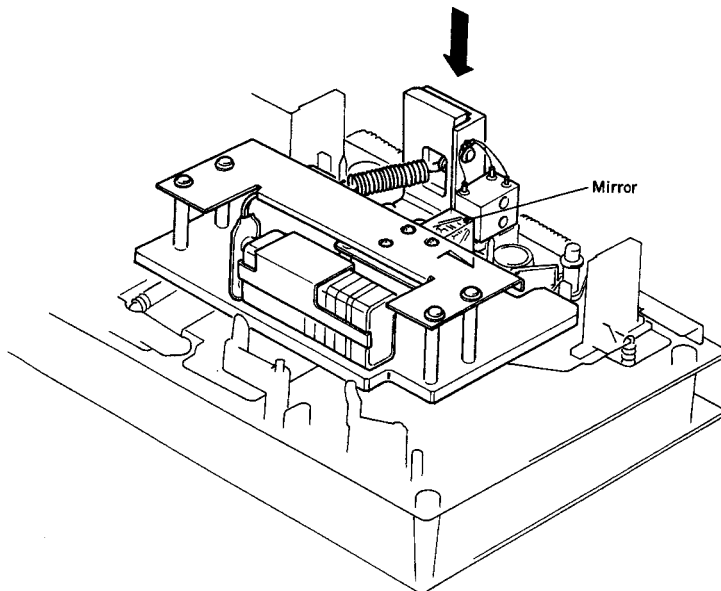

Fig. 5.11

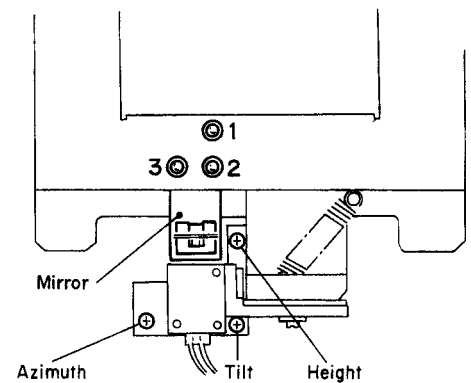

Fig. 5.12



### 5.7. Playback Head and Record Head Height Adjustment and Azimuth Alignment

Refer to Fig. 5.13.

#### (1) Playback Head Height Adjustment and Azimuth Alignment

- (a) Place the Monitor Switch in the Tape position, then connect VTVM to the Output Jacks.
- (b) Load a 1 kHz Track Alignment Tape (DA09007A), then set the N-582 in play mode.
- (c) Turn the PH Height Gear until the output of both channels becomes minimum.
- (d) Load a 15 kHz Azimuth Tape (DA09004A), then set the N-582 in play mode.
- (e) Turn the PH Azimuth Alignment Screw until the output of both channels becomes maximum.
- (f) Repeat (b) through (e) for 1 – 2 times.

#### (2) Record Head Height Adjustment and Azimuth Alignment

- (a) Place the Monitor Switch in the Tape position, then connect VTVM to the Output Jacks.
- (b) Load a Reference SX Tape (DA09025A). Set the Eq. and Tape Switches of the N-582 to 70  $\mu$ s and SX positions, then set the N-582 in record and play modes.
- (c) Set the Tone Switch of the N-582 to 400 Hz, then turn the RH Height Gear until the output of both channels becomes maximum.
- (d) Set the Tone Switch of the N-582 to 15 kHz, then turn the RH Azimuth Alignment Screw until the output of both channels becomes maximum.

- (e) Repeat (c) and (d) for 1 – 2 times.
- (f) After completion of both adjustment and alignment, record the 400 Hz tone to the same portion of both A and B sides of the tape.
- (g) Immerse the recorded tape in a magnetized developing solution. In turn, check to insure that the recording head tracks across the center are separated with a distance of 0.55 to 0.75 mm (typically 0.65 mm) as illustrated in Fig. 5.14.

Note: Liquid for tape magnetized development solution

"MAGNA-SEE, SOUND CRAFT a product of CBS RECORDS a division of Columbia Broadcasting System, Inc., Danbury, Conn. 06810 U.S.A., or equivalent".

After development, clean the tape otherwise pressure rollers and heads will become dirty.

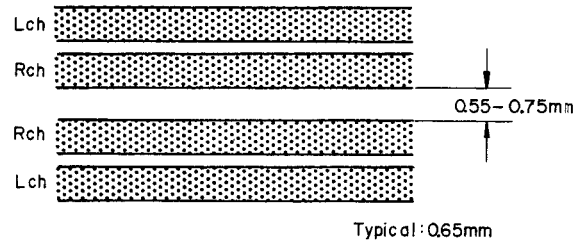

Fig. 5.14

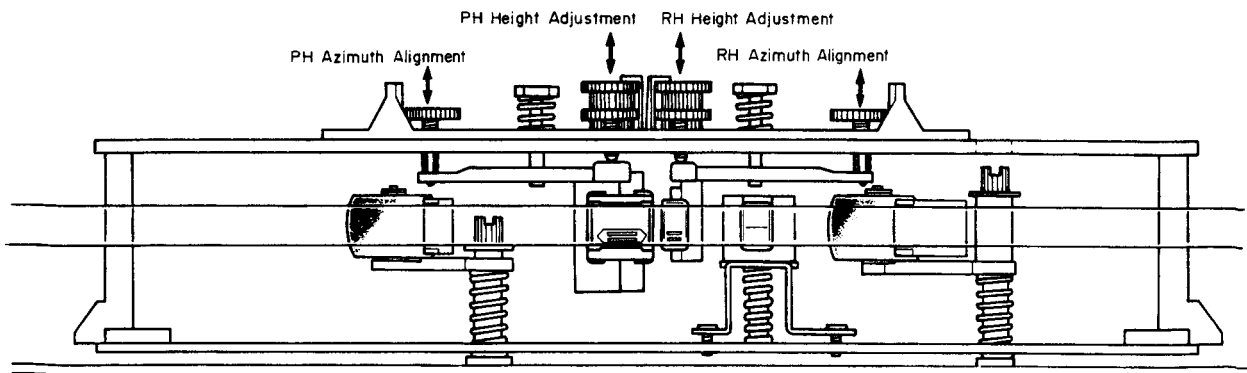

Fig. 5.13

### 5.8. Record Head Stroke Adjustment

Refer to Figs. 5.15 and 5.16.

Note: This adjustment will be required only to insure freedom from misalignment of the record head stroke in the record head stroke check mode.

- (1) Check the accuracy of the record head stroke.
- (2) Remove Head Mount Base Ass'y referring to item 3.28.
- (3) Remove the record head assembly.
- (4) Adjustment of Record Head Mounting Gauge M-9048 (DA09048A)
  - (a) Mount the Block B onto the Mounting Gauge Plate.
  - (b) Loosen the 2 screws fixing the Block A.
  - (c) As shown in the Fig. 5.15, hold the Gauges (3.05 mm and either one of 0.05, 0.15, 0.2, 0.25, 0.3 or 0.35 mm thickness) between the Block A and Block B, fix the Block A with screws, pushing the Block A to the 2 guide pins.
- (5) Remove the Block B from the Mounting Gauge Plate.
- (6) As shown in the Fig. 5.16, mount the R-54 record head assembly onto the Mounting Gauge Plate, then check the location of the R-54 record head surface. (If record head contacts to the Block C, loosen 2 pcs. of screws that assembled record head and R-54 record head assembly, then place the R-54 record head assembly onto the Plate.)
- (7) Remove the R-54 record head assembly from the Mounting Gauge Plate.
- (8) Readjustment of Record Head Mounting Gauge M-9048 (DA09048A)
  - (a) Mount the Block B onto the Mounting Gauge Plate.
  - (b) Loosen the 2 screws fixing the Block A.
  - (c) As shown in the Fig. 5.15, hold the Gauges (3.05 mm and either one of 0.05, 0.15, 0.2, 0.25, 0.3 or 0.35 mm thickness) between the Block A and Block B, fix the Block A with screw, pushing the Block A to the 2 guide pins.
- (9) Remove the Block B from the Mounting Gauge Plate.
- (10) Mount the R-54 record head assembly onto the Mounting Gauge Plate.
- (11) As shown in the Fig. 5.16, loosen the R-54 record head with 2 pcs. of screws onto the record head plate. As the location of the Block A is secured by the item (8) - (c), push the record head to the directions A and B, then tighten 2 pcs. of screws.
- (12) Check to insure freedom from gap between the Block C and record head surface, then tight the 2 pcs. of screws on the record head plate with lock tight paint.
- (13) Assemble the record head assembly to the head mount base assembly.
- (14) Assemble the head mount base assembly to the mechanism assembly.
- (15) Check the record head stroke.  
If the above are inaccurate, items (1) through (15) will have to be repeated till satisfactory results are obtained.

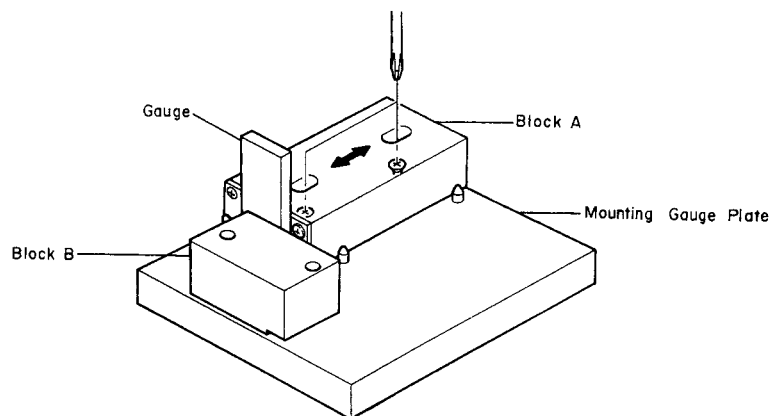
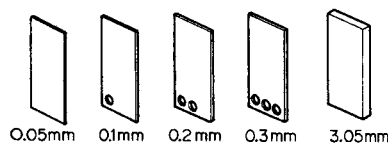

Fig. 5.15

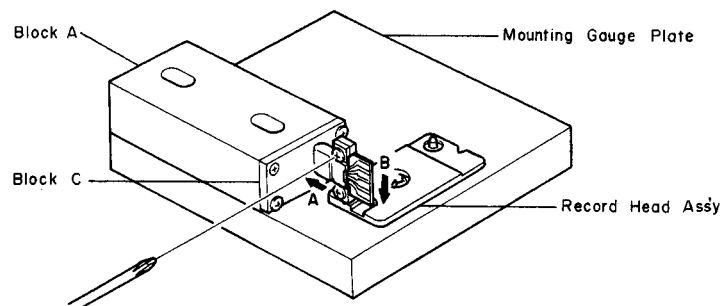

Fig. 5.16

### 5.9. Tape Travelling Adjustment

The adjustment shall be made with a modified version of the current type EXII C-90 as shown in Fig. 5.17 (error will be made if a current type Tape Travelling Cassette (DA09011A) should be used for this purpose).

While modifying an EXII C-90, the tape guides in the cassette housing shall be kept protected to avoid tilt. Check shall be made in the following procedures:

- (1) An EXII C-90 Tape thus modified shall be loaded onto the N-582.
- (2) Release the back-tension (rotate the Supply Reel and feed out some length of tape) and set the N-582 in play mode.
- (3) In this juncture, check to insure whether the tape is free from waving or slippage from the tape guide.
- (4) When the modified EXII C-90 is played back, check to insure whether the tape is freedom from waving from head surface or at pressure rollers.
- (5) If either of waving or slippage from the tape guide should be noted, adjustments of "5.3. Record Head and Playback Head Tilt Adjustment", "5.4. Head Base Stroke Adjustment", "5.5. Tape Guides Adjustment and Erase Head Stroke Adjustment", "5.6. Erase Head Height and Tilt Adjustment", "5.7. Playback Head and Record Head Height Adjustment and Azimuth Alignment", "5.8. Record Head Stroke Adjustment", etc. will be required.

As a case may be, the said waving or slippage may have been caused from defective supply Pressure Roller Ass'y or Take-up Pressure Roller Ass'y without parallel contact with capstans. If such are noted, the Pressure Roller Assemblies will have to be replaced.

Further, excessively weak take-up torque or strong take-up torque may cause defective tape travelling.

The N-582 is intended to be an adjustment-free Model, however if the similar matters as above should be noted, please replace the Reel Hub Ass'y to obtain appropriate take-up torque.

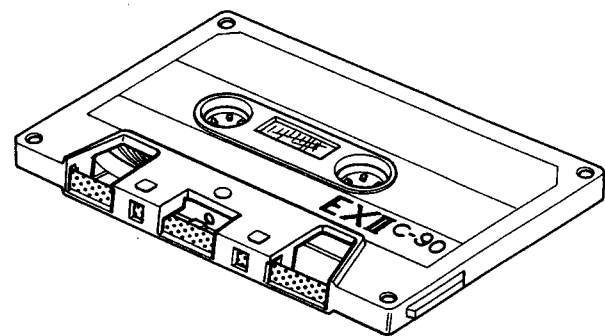

Fig. 5.17

### 5.10. Flywheel Holder Adjustment

- (1) Refer to Fig. 5.18.

Tighten the Thrust Screws until the gap between the Flywheel Assemblies and Thrust Screws becomes minimized when both of the Capstan Shafts are moved backwardly and forwardly (the Thrust Springs between the Capstan Flanges and Flywheel Thrust Caps are in a flat state).

Excessive tightening of the Thrust Screws however will give damages on the Flywheel Assemblies, to which careful attention is invited.

- (2) Return the Thrust Screws by 1/2 turn.
- (3) Fixing the Thrust Screw with a screwdriver, lock the Lock Nut.
- (4) Apply a quantity of lock tight paint to the Thrust Screws.

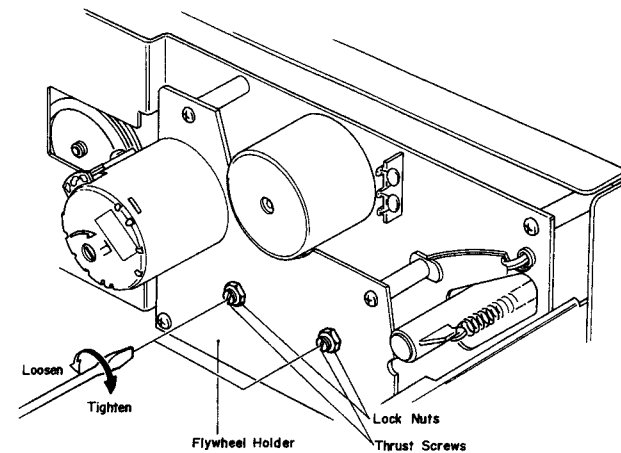

Fig. 5.18

### 5.11. Eject Wire Adjustment

- (1) Referring to Fig. 5.19.1, insert a 1.5 mm spacer between the Eject Arm and Eject Stopper by turning the Eject Arm in the illustrated direction, then set the N-582 in playback mode.
- (2) With pushing the Eject Arm by hand, loosen the screw and then pull the Eject Wire in the direction of the arrow until it stops as shown in Fig. 5.19.2.
- (3) Tighten the screw, then apply a quantity of lock tight paint.

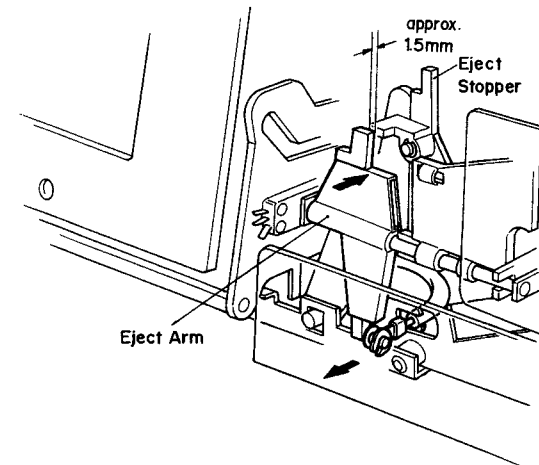

Fig. 5.19.1

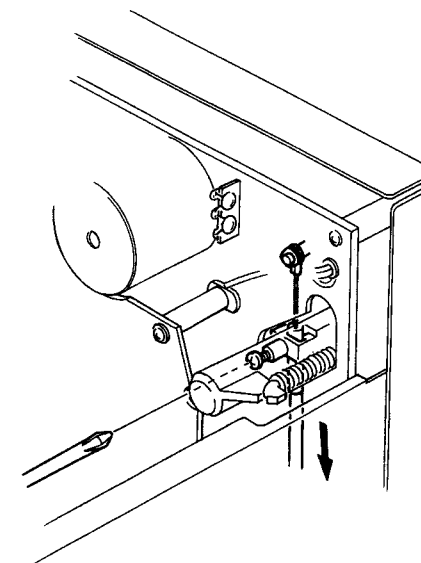

Fig. 5.19.2

### 5.12. Control Button Stroke Adjustment

Normal state of push button stroke for Logic Control on the Front Panel is as follows:

- (1) When Front Panel is in place, push the Control Button with a finger tip and see if it has an allowance of 0.6 mm. If it does, then push it a little further for another 0.4 mm and see if the switch is ON.

This allowance can be adjusted by loosening the screws that assembled Control Button Holder and Front Chassis together. After the adjustment, lock the screws with lock tight paint.

- (2) When performing adjustment, put the Front Panel aside, but for checking, do it with the Panel on.

### 5.13. Lubrication

N-582 is a lubrication-free cassette deck except when parts are replaced. Apply the following lubricant for each replaced part:

- (1) LAUNA #100  
Capstan Shaft  
Pressure Roller Shaft  
Thrust Cap
- (2) FLOIL GB-TS-1  
Reel Hub Shaft  
Thrust portion on the Capstan Shaft  
FLOIL GB-TS-1, made by Kanto Chemicals Co., Ltd., in Japan.
- (3) Silicon Oil #3000CST  
Air Damper Piston

Note: Excessive lubrication may cause defective damper action as the 0.2φ hole at the end of the cylinder may be filled with oil.

6. PARTS LOCATION FOR ELECTRICAL ADJUSTMENT

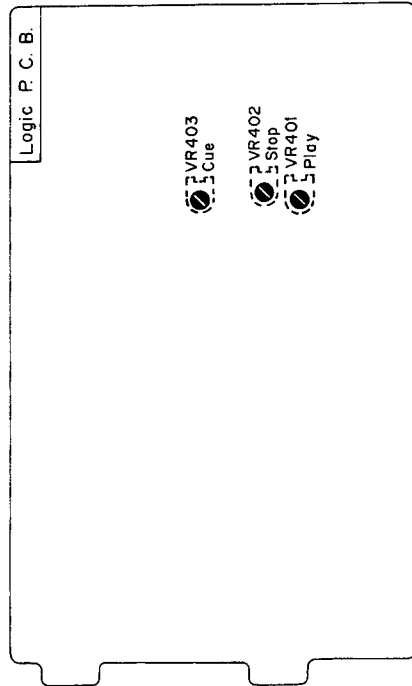
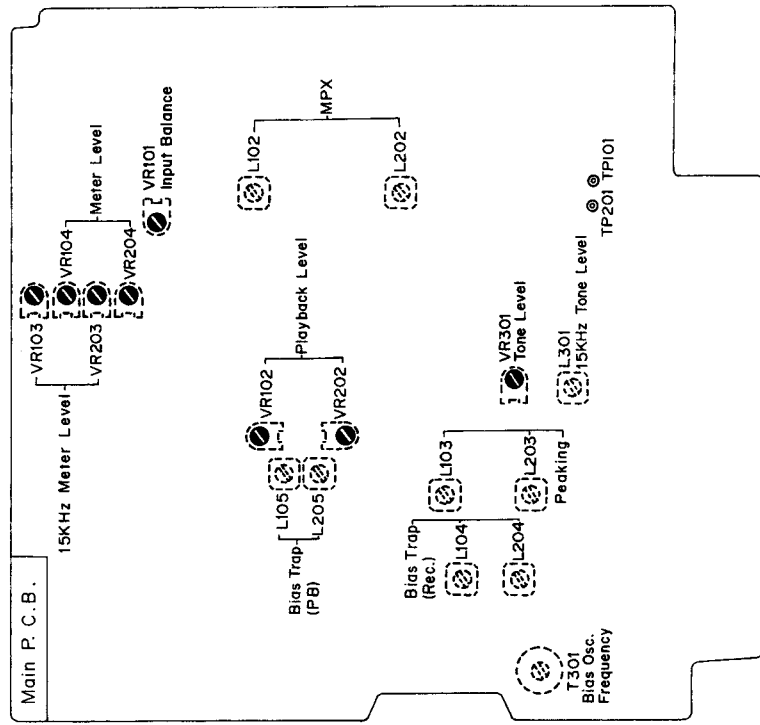

Fig. 6.1 Serial No: A11105952 –

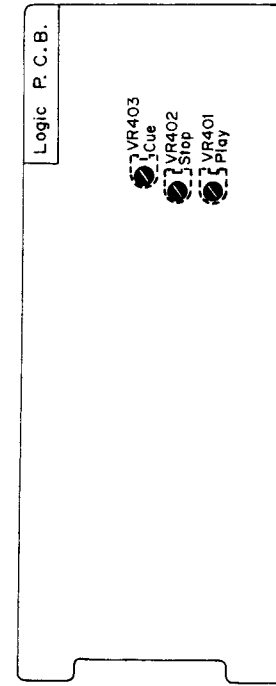
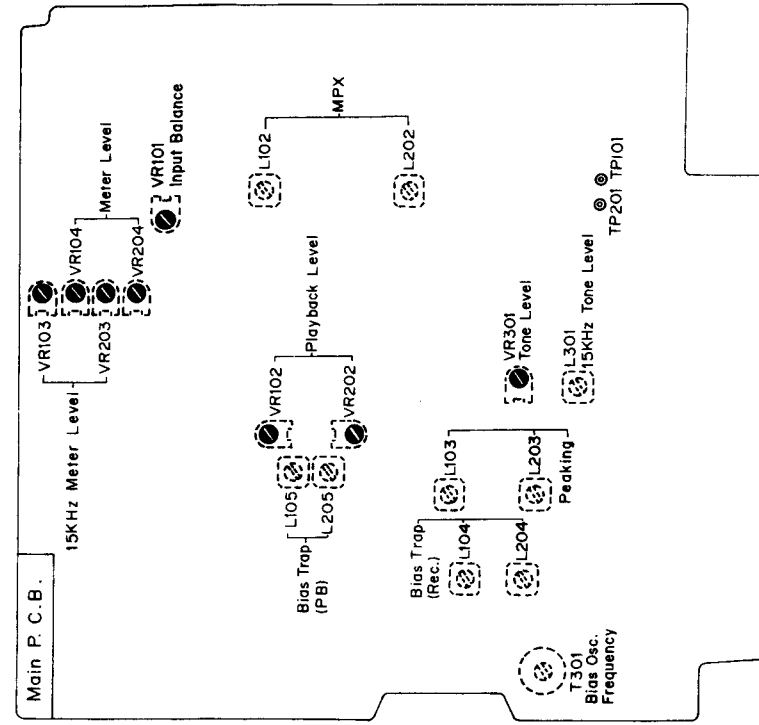
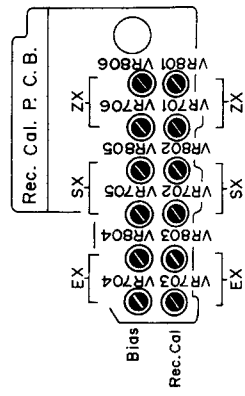
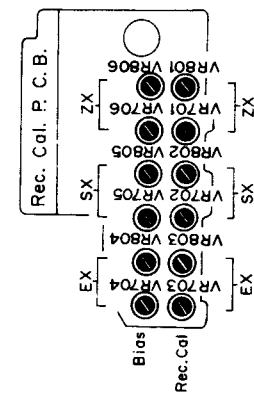

Fig. 6.2 Serial Nos: A11101001 – A11105951



7. ELECTRICAL ADJUSTMENTS AND MEASUREMENTS

7.1. Adjustment and Measurement Instruction

Note: Electrical adjustment should be performed after mechanical adjustment is completed.

STEP	ITEM	SIGNAL SOURCE	OUTPUT CONNECTION	MODE	ADJUSTMENT	REMARKS
1	Tape Speed	3 kHz Speed and Wow/Flutter Tape (DA09006A)	Frequency Counter to OUTPUT Jacks	Playback	Capstan Motor Governor P.C.B. VR501	Adjust VR501 to obtain 3 kHz $\pm$ 0.5%. (VR501 is incorporated in the Motor.)
2	Tone Calibration	Test Tone 400 Hz and 15 kHz	VTVM to TP101, TP201 on the Main P.C.B.	Monitor SW – Source Test Tone SW – 400/15 k	Main P.C.B. VR301, VR101, L301	<ol style="list-style-type: none"> <li>1. Set the Test Tone Switch to 400 Hz. Turn output level control fully clockwise (maximum position).</li> <li>2. Adjust VR301 to obtain 100 mV <math>\pm</math> 0.2 dB on the VTVM at TP201 (output will be 1 V (0 dB)).</li> <li>3. Adjust VR101 to obtain the same level as Right channel on the VTVM at TP101.</li> <li>4. Set the Test Tone Switch to 15 kHz.</li> <li>5. Adjust L301 to obtain 10 mV <math>\pm</math> 0.5 dB on the VTVM (output will be -20 dB against the level at 400 Hz).</li> </ol>
3	Meter Level	Test Tone 400 Hz and 15 kHz or 400 Hz and 15 kHz to INPUT Jacks	VTVM to TP101, TP201 on the Main P.C.B.	Monitor SW – Source Test Tone SW – 400/15k	Main P.C.B. VR104, VR204 VR103, VR203	<ol style="list-style-type: none"> <li>1. Set the Test Tone Switch to 400 Hz.</li> <li>2. Adjust VR104 (VR204) to obtain 0 dB on the level meters at 100 mV level on the VTVM.</li> <li>3. Decrease input level by 10 dB/20 dB then short or open R168 (R268) and/or R169 (R269) to obtain minimum deviation from -10 dB/-20 dB on the level meters. (Perform at -10 dB and -20 dB.)</li> <li>4. Again increase input level so that output will become 100 mV, then re-adjust VR104 (VR204) to obtain 0 dB on the level meters.</li> <li>5. Set the Test Tone Switch to 15 kHz.</li> <li>6. Adjust VR103 (VR203) to obtain 0 dB on the level meters at 10 mV level on the VTVM.</li> </ol>
4	MPX Filter	19 kHz $\pm$ 100 Hz to INPUT Jacks	VTVM to OUTPUT Jacks	Monitor SW – Source Test Tone SW – OFF Dolby NR SW – OUT, IN/MPX	Main P.C.B. L102, L202	<ol style="list-style-type: none"> <li>1. Turn output level control fully clockwise (maximum position).</li> <li>2. Adjust input level control to obtain 1 V on the VTVM.</li> <li>3. Set the Dolby NR Switch to IN/MPX position, then adjust L102 (L202) to obtain minimum reading on the VTVM (minimum reading will be less than -30 dB).</li> </ol>
5	Playback Head Track Alignment	1 kHz Track Alignment Tape (DA09007A)	VTVM to OUTPUT Jacks	Playback Monitor SW – Tape Test Tone SW – OFF Eq. SW – 70 $\mu$ s Dolby NR SW – OUT	Playback Head Height Adj. Screw	Adjust the Playback Head Height Adj. Screw to obtain minimum reading of both L and R channels on the VTVM. See "Playback Head Height Adjustment and Azimuth Alignment" in item 5.7.

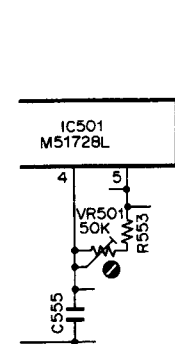

Fig. 7.1  
1. Tape Speed

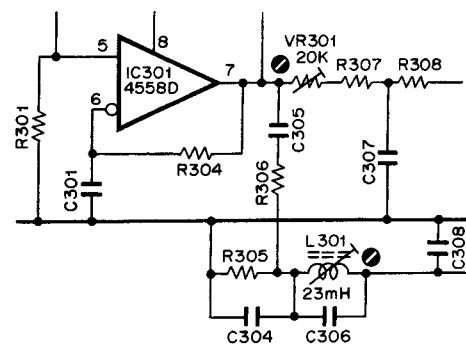

Fig. 7.2  
2. Tone Calibration

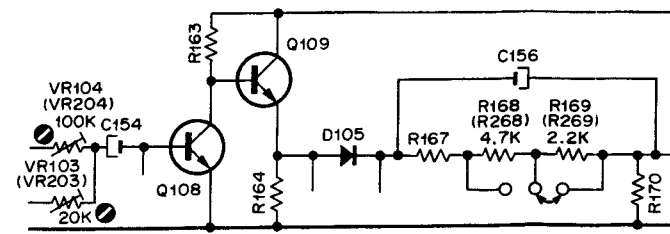

Fig. 7.3  
3. Meter Level

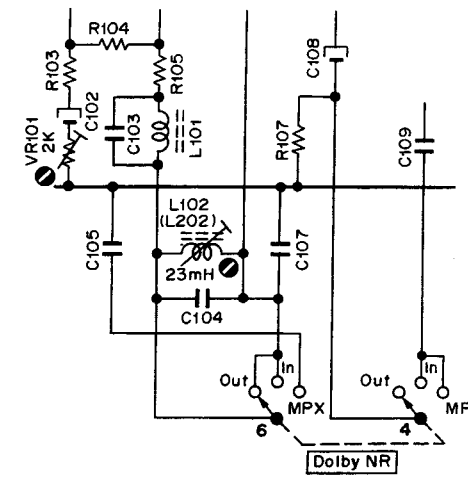

Fig. 7.4  
2. Tone Calibration  
4. MPX Filter

STEP	ITEM	SIGNAL SOURCE	OUTPUT CONNECTION	MODE	ADJUSTMENT	REMARKS
6	Playback Head Azimuth Alignment	15 kHz Azimuth Tape (DA09004A)	VTVM to OUTPUT Jacks	Playback Monitor SW – Tape Test Tone SW – OFF Eq. SW – 70 μs Dolby NR SW – OUT	Playback Head Azimuth Alignment Screw	Adjust the Playback Head Azimuth Alignment Screw to obtain maximum reading of both L and R channels on the VTVM. See "Playback Head Height Adjustment and Azimuth Alignment" in item 5.7. Note: Repeat steps 5 and 6 one or two times to obtain optimum performance.
7	Playback level	400 Hz Level Tape (DA09005A)	VTVM to TP101, TP201	Same as above	Main P.C.B. VR102, VR202	Adjust VR102 (VR202) to obtain 100 mV on the VTVM or 0 dB on the level meters.
8	Playback Frequency Response	400 Hz Level Tape (DA09005A) 10 kHz PB Frequency Response Tape (DA09003A) 15 kHz PB Frequency Response Tape (DA09002A) 20 kHz PB Frequency Response Tape (DA09001A)	VTVM to OUTPUT Jacks	Playback Monitor SW – Tape Tape SW – SX Eq. SW – 70 μs Dolby NR SW – OUT	Main P.C.B. R147, R247 R148, R248	1. Load the 400 Hz level tape and play it back. Adjust the output level control to a certain level (example 0 dB). 2. Load the 10 kHz, 15 kHz and 20 kHz PB frequency response tapes and adjust the playback head azimuth to give maximum levels on the VTVM with each tape. Short R147 (R247) and/or R148 (R248) to obtain the following level against 400 Hz level tape. Refer to Fig. 7.5. 10 kHz: -20 dB -1 dB to +2 dB 15 kHz: -20 dB -1 dB to +3 dB 20 kHz: -20 dB -1 dB to +4 dB 3. Conduct step 6 "Playback Head Azimuth Alignment". 4. If above is not sufficient, refer to "Playback Frequency Response Adjustment" in item 7.2.1.
9	Bias Oscillation Frequency and Erase Current	Connect an additional 0.1Ω resistor in series to the Erase Head	VTVM and Frequency Counter across the additional 0.1Ω resistor	Record, Pause Monitor SW – Source Tape SW – ZX Eq. SW – 70 μs Dolby NR SW – OUT	Main P.C.B. T301 R319, R341	1. Adjust T301 to obtain 105 kHz on the frequency counter. 2. Check the erase current by the VTVM. Erase current will be in a range of 310 mA to 400 mA (typically approx. 350 mA). If erase current is not sufficient, increase it by shorting R319 or R341. 3. After completion of the erase current adjustment, re-check the bias oscillation frequency.
10	Record Amplifier Equalizer	23 kHz (-20 dB) to INPUT Jacks	VTVM to Main P.C.B. CN5-1, CN5-3	Same as above	Main P.C.B. L103, L203	1. Remove the bias-cut-jumper from the dip side of the main P.C.B. 2. Adjust L103 (L203) to obtain peak reading at 23 kHz on the VTVM. 3. Re-solder the bias-cut-jumper.
11	Bias Trap (Record Amp.)	Remove Input Signals	Same as above	Same as above	Main P.C.B. L104, L204	Adjust L104 (L204) to obtain maximum reading on the VTVM.

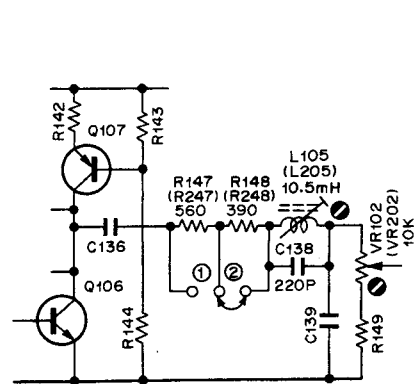

Fig. 7.5  
7. Playback Level  
12. Bias Trap (Playback Amp.)

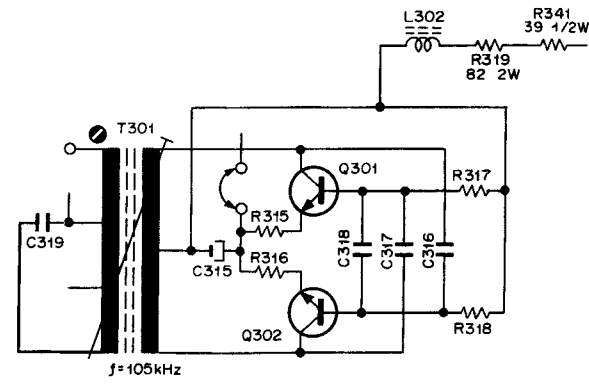

Fig. 7.6  
9. Bias Oscillation Frequency and Erase Current

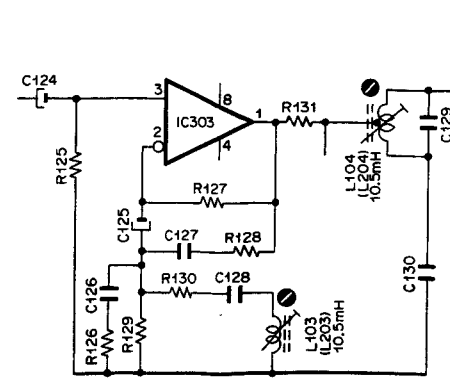

Fig. 7.7  
10. Record Amplifier Equalizer  
11. Bias Trap (Record Amp.)  
16. Record/Playback Frequency Response

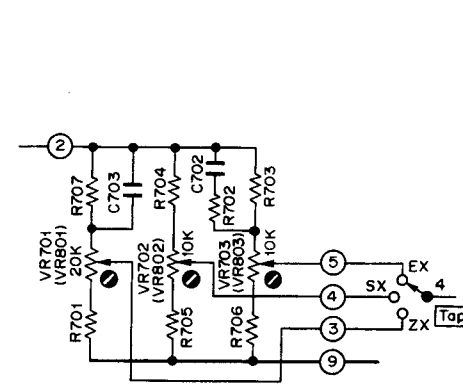

Fig. 7.8  
15. Record Level

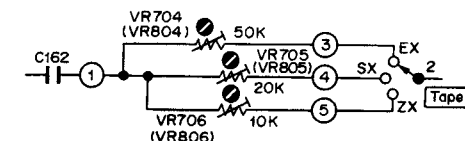

Fig. 7.9  
15. Recording Bias Current

STEP	ITEM	SIGNAL SOURCE	OUTPUT CONNECTION	MODE	ADJUSTMENT	REMARKS
12	Bias Trap (Playback Amp.)	Remove Input Signals	VTVM to OUTPUT Jacks	Record, Pause Monitor SW – Tape Tape SW – ZX Eq. SW – 70 $\mu$ s Dolby NR SW – OUT	Main P.C.B. L105, L205	Adjust L105 (L205) to obtain minimum reading on the VTVM.
13	Record Head Height Adjustment	Test Tone 400 Hz	Same as above	Record, Playback Monitor SW – Tape Tape SW – SX Eq. SW – 70 $\mu$ s Dolby NR SW – OUT	Record Head Height Adj. Screw	Adjust the Record Head Height Adj. Screw to obtain maximum reading of L and R channels on the VTVM. See "Record Head Height Adjustment and Azimuth Alignment" in item 5.7.
14	Record Head Azimuth Alignment	Test Tone 15 kHz	Same as above	Same as above	Record Head Azimuth Alignment Screw	Adjust the Record Head Azimuth Alignment Screw to obtain maximum reading of L and R channels on the VTVM. See "Record Head Height Adjustment and Azimuth Alignment" in item 5.7.
15	Record Level Calibration and Recording Bias Current Adjustment	Test Tone 400 Hz and 15 kHz or 400 Hz and 15 kHz to INPUT Jacks	VTVM and Distortion Meter to OUTPUT Jacks	Record, Playback Monitor SW – Tape Tape SW – EX/SX/ZX Eq. SW – 120 $\mu$ s (EX) 70 $\mu$ s (SX/ZX) Tone SW – 400 Hz/15 kHz Dolby NR SW – OUT	Rec. Cal. P.C.B. VR701, VR702, VR703, VR801, VR802, VR803, VR704, VR705, VR706, VR804, VR805, VR806	<ol style="list-style-type: none"> <li>Set the Tone Switch to 400 Hz.</li> <li>Record signals on the reference EXII tape (DA09021A), reference SX tape (DA09025A), or reference ZX tape (DA09037A), then play it back.</li> <li>Adjust Rec. Cal. VR703 (VR803) (for EXII), VR702 (VR802) (for SX) and VR701 (VR801) (for ZX) to the center their positions.</li> <li>Adjust Bias VR704 (VR804) (for EXII), VR705 (VR805) (for SX) and VR706 (VR806) (for ZX) to obtain maximum reading on the VTVM.</li> <li>Set the Tone Switch to 15 kHz.</li> <li>Adjust Bias VR704 (VR804), VR705 (VR805) and VR706 (VR806) to obtain the same readings as source monitor levels on the VTVM.</li> <li>Set the Tone Switch to 400 Hz.</li> <li>Adjust Rec. Cal. VR703 (VR803), VR702 (VR802) and VR701 (VR801) to obtain 0 dB on the level meters.</li> <li>Repeat 5 through 8 as above two or three times to obtain optimum performance.</li> <li>Check whether Total Harmonic Distortion (T.H.D.) is less than 1.0% for EXII, SX and ZX tapes.</li> </ol>
16	Record/Playback Frequency Response	400 Hz (0 dB) and 20 Hz to 20 kHz (-20 dB) to INPUT Jacks	Same as above	Record, Playback Monitor SW – Source/Tape Tape SW – EX/SX/ZX Eq. SW – 120 $\mu$ s (EX) 70 $\mu$ s (SX/ZX) Tone SW – OUT Dolby NR SW – OUT	Main P.C.B. L103, L203	<ol style="list-style-type: none"> <li>Set the Monitor Switch to Source.</li> <li>Feed in 400 Hz (0 dB) and adjust record level controls to obtain 0 dB on the level meters.</li> <li>Switch the Generator output level to -20 dB.</li> <li>Set the Monitor Switch to Tape, then record and play it back.</li> <li>Feed in 20 Hz to 20 kHz (-20 dB), and check to insure if the output levels are within -20 dB <math>\pm</math> 3 dB.</li> <li>If above is not sufficient, adjust L103 (L203) to obtain approx. -20 dB on the VTVM.</li> <li>Conduct step 15 "Record Level Calibration and Recording Bias Current Adjustment".</li> <li>If above is not sufficient, precise re-adjustment of step 8 "Playback Frequency Response", replacement of Playback Head or Record Head, or check on item 5.9 "Tape Travelling Adjustment" will be required.</li> </ol>
17	Crosstalk	1 kHz to INPUT Jacks	1 kHz Band Pass Filter, VTVM to OUTPUT Jacks	Record and Playback Monitor SW – Tape Tape SW – ZX Eq. SW – 70 $\mu$ s Dolby NR SW – OUT		<ol style="list-style-type: none"> <li>Erase the tape with bulk eraser.</li> <li>Adjust record level controls to obtain 0 dB on the level meters, and record the signals on the reference tape.</li> <li>Turn the cassette tape the other way round and play it back.</li> <li>Measure the difference between 2 and 3.</li> </ol>
18	Channel Separation	1 kHz to INPUT Jacks	Same as above	Same as above		<ol style="list-style-type: none"> <li>Erase the tape with bulk eraser.</li> <li>Adjust Lch (Rch) record level control to obtain 0 dB on the level meter, and close Rch (Lch) record level control.</li> <li>Record and play it back, then measure the Rch (Lch) level.</li> </ol>

STEP	ITEM	SIGNAL SOURCE	OUTPUT CONNECTION	MODE	ADJUSTMENT	REMARKS
19	Erase	1 kHz to INPUT Jacks	1 kHz Band Pass Filter, VTVM to OUTPUT Jacks	Record and Playback Monitor SW – Tape Tape SW – ZX Eq. SW – 70 $\mu$ s Dolby NR SW – OUT		1. Erase the tape with bulk eraser. 2. Adjust record level controls to obtain 0 dB on the level meters, and record the signals on the reference tape. 3. Rewind the tape then close record level controls. 4. Record and play it back, then measure the difference between 2 and 3.
20	Signal to Noise Ratio	400 Hz to INPUT Jacks	VTVM and Distortion Meter to OUTPUT Jacks	Record and Playback Monitor SW – Tape Tape SW – ZX Eq. SW – 70 $\mu$ s Dolby NR SW – IN/MPX		1. Feed in 400 Hz and record, and play it back. 2. Adjust the record level controls to obtain 3% total harmonic distortion in playback mode. 3. Close the record level controls then record. 4. After rewind, play back and check the output level difference between 2 and 3. Note: The filter of IHF-A curve shall be used in the measurements.
21	Total Harmonic Distortion	400 Hz to INPUT Jacks	Distortion Meter to OUTPUT Jacks	Record and Playback Monitor SW – Tape Tape SW – EX/SX/ZX Eq. SW – 120 $\mu$ s (EX) 70 $\mu$ s (SX/ZX) Dolby NR SW – OUT		1. Adjust record level controls to obtain 0 dB on the level meters. 2. Record and play it back. 3. Read the distortion meter and check to insure that the distortion is less than 1.0% for each tape.
22	Wow/Flutter	3 kHz Speed and Wow/Flutter Tape (DA09006A)	Wow/Flutter Meter to OUTPUT Jacks	Playback Monitor SW – Tape Eq. SW – 70 $\mu$ s		Playback and read the wow/flutter meter.

7.2. Frequency Response Adjustment

7.2.1. Playback Frequency Response Adjustment

Fig. 7.10 shows the playback equalization curve for N-582, and Fig. 7.11 is the circuit for adjustment.

(1) Level Adjustment (for middle frequency response)

This adjustment will be required when playback level is not sufficient at 10 kHz PB Frequency Response Tape (refer to step 8 in "7.1. Adjustment and Measurement Instructions").

Playback equalization level can be varied by the modification of R145 (R245) and R146 (R246).

Following are the details for level modification:

- Approx. +1 dB ..... R146 (R246): 3.0K  
R145 (R245): 4.3K
- 0 dB ..... R146 (R246): 3.3K  
R145 (R245): 4.7K
- Approx. -1 dB ..... R146 (R246): 3.6K  
R145 (R245): 5.1K

(2) For SX Tape

- (a) Feed in 15 kHz and 400 Hz (-20 dB), then record and play it back. Adjust bias current by VR705 (VR805) to obtain flat overall frequency response.
- (b) Feed in 20 kHz and 400 Hz (-20 dB), then record and play it back. And check to insure that the overall frequency response is flat.

(3) For EX Tape

- (a) Feed in 15 kHz and 400 Hz (-20 dB), then record and play it back. Adjust bias current by VR704 (VR804) to obtain flat overall frequency response.

- (b) Feed in 20 kHz and 400 Hz (-20 dB), then record and play it back. And check to insure that the overall frequency response is flat.

(2) Peaking Adjustment (for high frequency response)

This adjustment will be required when playback level is not sufficient at 20 kHz PB Frequency Response Tape (refer to step 8 in "7.1. Adjustment and Measurement Instructions").

Peaking portion compensates the gap loss of the playback head.

Peaking level is varied by the short circuit of R147 (R247) or R148 (R248) as illustrated in the figure.

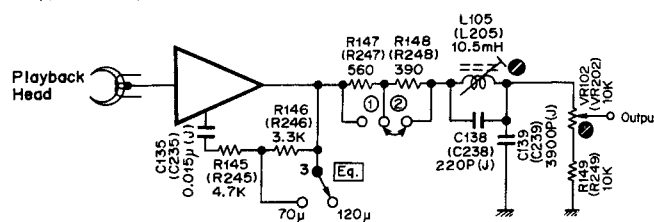

Fig. 7.11 Playback Amp.

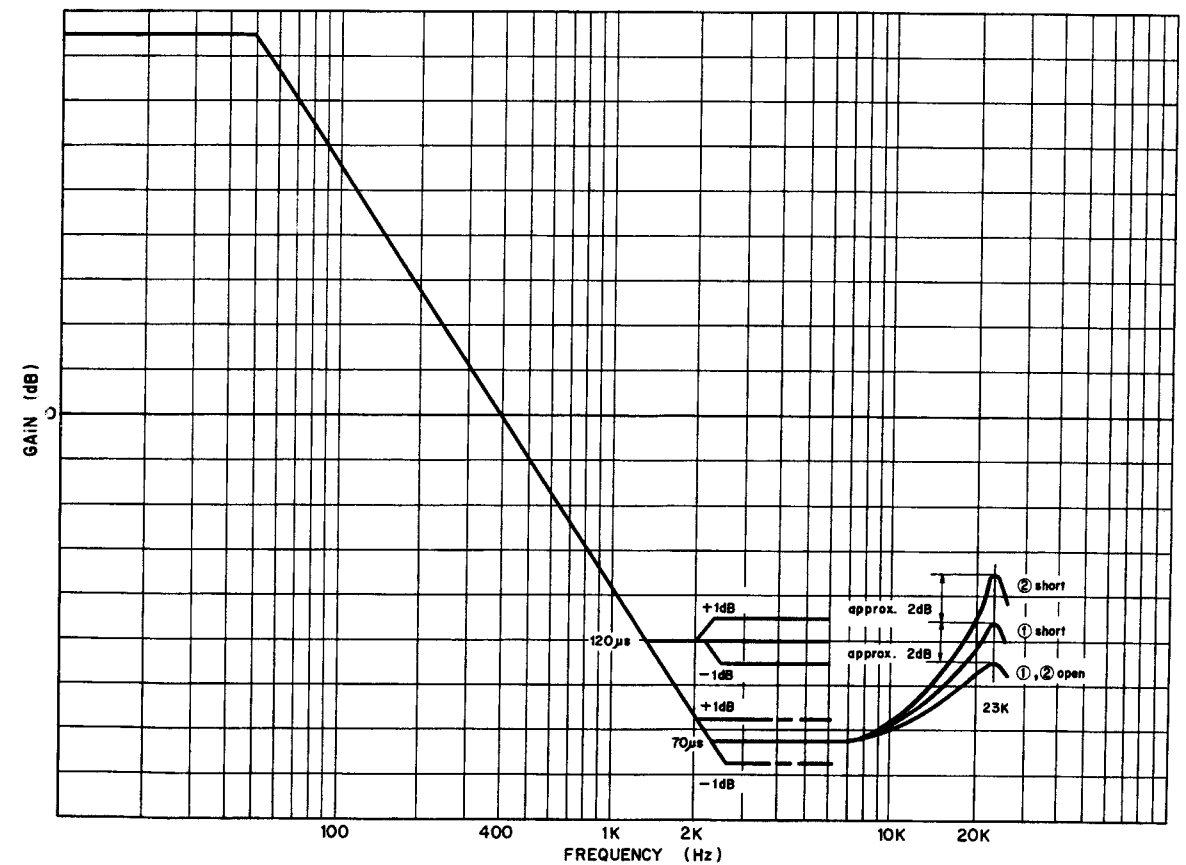

Fig. 7.10 Playback Equalization Curve



**7.2.2. Record Current Frequency Response Adjustment**  
Record Eq. Peaking is adjusted for compensating the overall frequency response when playback frequency response is completed.

Normally however peaking frequency is pre-adjusted to approx. 23 kHz in Record mode. Refer to Fig. 7.12.

**(1) For ZX Tape**

- (a) Feed in 400 Hz (0 dB), then record and play it back. Adjust bias current by VR706 (VR806) to obtain a 1% distortion.
- (b) Feed in 10 kHz and 400 Hz (-20 dB) then record and play it back. Check the difference of the levels between 10 kHz and 400 Hz, and mount an additional capacitor in parallel with the C122 (C222) from the dip side of the printed circuit board depending upon the difference of the levels against 400 Hz. Refer to Fig. 7.13.

	<u>Add</u>	<u>Total</u>
0 dB	0	1000 pF
-1 dB	470 pF	1470 pF
-2 dB	1000 pF	2000 pF

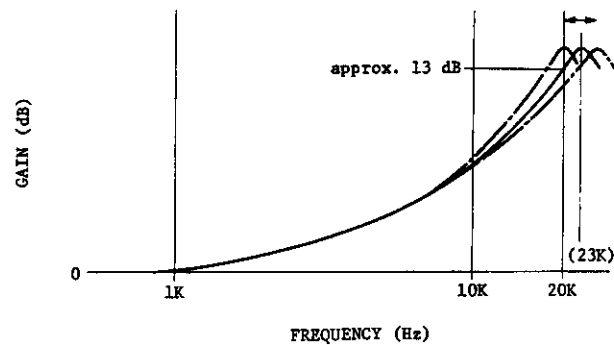

Fig. 7.12 Recording Peaking Curve

- (c) Feed in 20 kHz (-20 dB) then record and play it back. Adjust record peaking coils L103 (L203) to obtain flat overall frequency response.

**2) For SX Tape**

- a) Feed in 15 kHz and 400 Hz (-20 dB), then record and play it back. Adjust bias current by VR705 (VR805) to obtain flat overall frequency response.
- b) Feed in 20 kHz and 400 Hz (-20 dB), then record and play it back. And check to insure that the overall frequency response is flat.

**3) For EX Tape**

- a) Feed in 15 kHz and 400 Hz (-20 dB), then record and play it back. Adjust bias current by VR704 (VR804) to obtain flat overall frequency response.
- b) Feed in 20 kHz and 400 Hz (-20 dB), then record and play it back. And check to insure that the overall frequency response is flat.

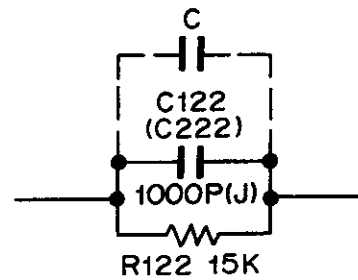

Fig. 7.13

**7.3. Dolby NR Circuit Check**

Dolby NR circuit incorporates a Dolby B-Type NR IC ( $\mu$ A7300PC) which has no adjustment point.

Perform the following checks and make sure that the IC operates accurately i.e. accuracy of frequency response through IC.

**(1) Playback Dolby NR Circuit**

- Signal Source: 5 kHz to No.9 pin of IC102 and IC202.
- Output Connection: VTVM to the test points TP101 and TP201 on the Main P.C.B.
- Mode: Stop  
Monitor SW - Tape  
Dolby NR SW - OUT/IN

- (a) Connect VTVM to TP101 (TP201) on the Main P.C.B. Feed in 5 kHz to No.9 of IC102 (IC202) and adjust the generator output control so that the VTVM may read 7.6 mV at each Test Point.
- (b) Set the Dolby NR switch to IN. Check to insure that level at TP101 (TP201) is 3 mV  $\pm$  1.5 dB.

**(2) Record Dolby NR Circuit**

- Signal Source: 5 kHz to INPUT Jacks
- Output Connection: VTVM to the output side of C117 (C217) on the Main P.C.B.
- Mode: Stop  
Monitor SW - Source

- (a) Connect a VTVM to TP101 (TP201) on the Main P.C.B. Feed in 5 kHz and adjust the input level so that the VTVM may read 100 mV (0 dB) at each Test Point. Pointer on the meter will indicate 0 dB.
- (b) Remove the VTVM from TP101 (TP201) and reconnect it to the output side of C117 (C217). Check to insure that the VTVM indicates approx. 560 mV.
- (c) Decrease the input level (0 dB) by 20 dB or 30 dB. Check to insure that the level at output side of C117 (C217) corresponds to the following with Dolby NR switch IN and OUT.

Input Level	Capacitor Output Level		
	Dolby NR OUT	Dolby NR IN	Difference between IN and OUT
(f=5 kHz)			
-20 dB	-20 dB	-16.8 dB $\pm$ 1.5 dB	3.2 dB $\pm$ 1.5 dB
-30 dB	-30 dB	-21.8 dB $\pm$ 1.5 dB	8.2 dB $\pm$ 1.5 dB

8. MOUNTING DIAGRAMS AND PARTS LIST

Note: Mounting diagram shows a dip side view of the printed circuit board.

8.1. Main P.C.B. Ass'y

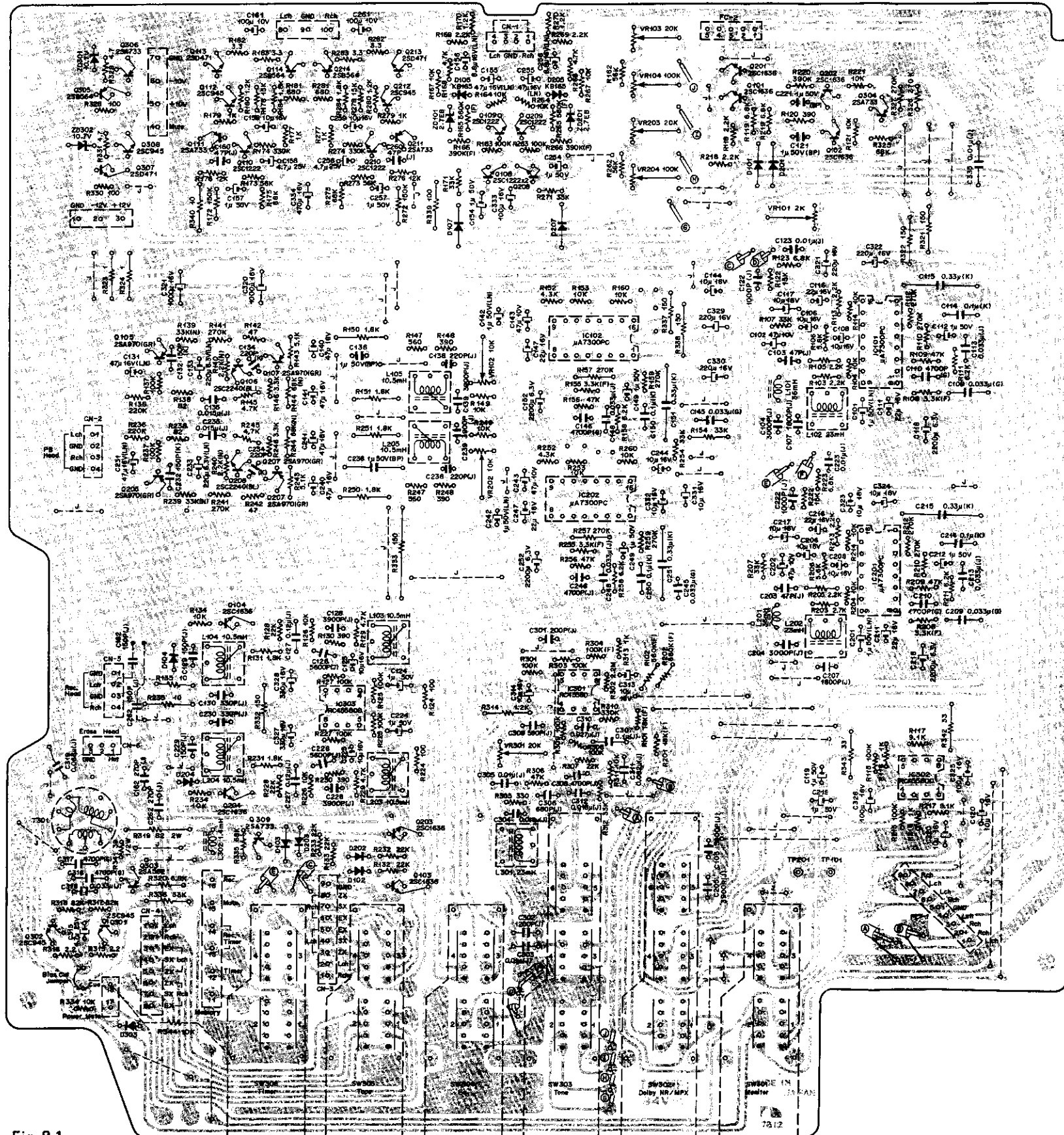

Fig. 8.1

Note: Diode is 1SS53, 1S953, or 1S1555 unless otherwise specified.

Schematic Ref. No.	Part No.	Description
	<b>BA04016B</b>	<b>Main P.C.B. Ass'y</b>
		<b>- PB Eq. Amp. -</b>
Q105,107 205,207	OB06180A	Transistor 2SA970 (GR)
Q106,206	OB06142A	Transistor 2SC2240 (BL)
L105,205	OB00068A	Trap Coil 10.5mH
VR102,202	OB07236A	Semi-fixed Volume 10K
R136,236	OB05625A	Carbon Resistor 220K ERD-25V J
R137,237	OB01920A	Carbon Resistor 100K ERD-25V J
R138,238	OB05503A	Carbon Resistor 82 ERD-25V J
R139,239	OB09239A	Carbon Resistor 33K ERD-25VS J (Noiseless)
R140,240	OB09244A	Carbon Resistor 2.2K ERD-25VS J (Noiseless)
R141,241	OB05600A	Carbon Resistor 270K ERD-25V J
R142,242	OB05569A	Carbon Resistor 47 ERD-25V J
R143,243	OB09186A	Carbon Resistor 5.1K ERD-25V J
R144,244	OB09268A	Carbon Resistor 68K ERD-25VS J (Noiseless)
R145,245	OB01795A	Carbon Resistor 4.7K ERD-25V J
R146,246	OB01793A	Carbon Resistor 3.3K ERD-25V J
R147,247	OB05678A	Carbon Resistor 560 ERD-25V J
R148,248	OB05688A	Carbon Resistor 390 ERD-25V J
R149,249	OB01833A	Carbon Resistor 10K ERD-25V J
R150,151 250,251	OB05614A	Carbon Resistor 1.8K ERD-25T J
C131,231	OB09218A	Electrolytic Capacitor 47μ 16V (LN)
C132,232	OB09281A	Ceramic Capacitor 150P 50V K
C133,233	OB09151A	Electrolytic Capacitor 220μ 6.3V (LN)
C134,234	OB09283A	Ceramic Capacitor 220P 50V K
C135,235	OB05557A	Mylar Capacitor 0.015μ 50V J
C136,236	OB09187A	Electrolytic Capacitor 1μ 50V (BP)
C138,238	OB09247A	Mica Capacitor 220P 50V J
C139,239	OB01804A	Mylar Capacitor 3900P 50V J
C140,141 240,241	OB01403A	Electrolytic Capacitor 47μ 16V
		<b>- Line Amp. -</b>
IC302	OB06146A	IC RC4558DD
Q101,102 201,202	OB06070A	Transistor 2SC1636
Q304,306	OB06013A	Transistor 2SA733
Q305	OB06069A	Transistor 2SB564
Q307	OB06066A	Transistor 2SD471
Q308	OB01872A	Transistor 2SC945
D101,201	OB06181A	Silicon diode 1SS53
ZD301,302	OB06199A	Zener Diode 10.7V
R115,215	OB01920A	Carbon Resistor 100K ERD-25V J
R116,216	OB01781A	Carbon Resistor 1K ERD-25V J
R117,217	OB09184A	Carbon Resistor 9.1K ERD-25V J
R118,218	OB05566A	Carbon Resistor 2.2K ERD-25V J
R119,219	OB01877A	Carbon Resistor 6.8K ERD-25V J
R120,220	OB05688A	Carbon Resistor 390 ERD-25V J
R121,221	OB01833A	Carbon Resistor 10K ERD-25V J
R323,324	OB09214A	Fail Safe Type Resistor 1 RDF25S J
R325	OB01902A	Carbon Resistor 68K ERD-25V J
R326,327	OB05600A	Carbon Resistor 270K ERD-25V J
R328,330	OB09215A	Fail Safe Type Resistor 100 RDF25S J
R329,331	OB09243A	Fail Safe Type Resistor 4.7 RDF50S J
R342,343	OB09210A	Fail Safe Type Resistor 33 RDF25S J

Schematic Ref. No.	Part No.	Description	Schematic Ref. No.	Part No.	Description	Schematic Ref. No.	Part No.	Description	Schematic Ref. No.	Part No.	Description	
R344 C119, 219 C120, 220 C121, 221 C320, 321 C325, 326	0B01888A 0B01405A 0B01412A 0B09187A 0B01397A 0B01400A	Carbon Resistor 10K ERD-25T J Electrolytic Capacitor 1μ 50 V Electrolytic Capacitor 10μ 16 V Electrolytic Capacitor 1μ 50 V (BP) Electrolytic Capacitor 1000μ 16V Electrolytic Capacitor 100μ 16 V	R332, 333 R335 R336 C122, 222 C123, 223 C124, 224 C125, 225 C126, 226 C127, 227 C128, 228 C129, 229 C130, 320 C327, 328	0B09213A 0B01902A 0B01879A 0B05550A 0B05681A 0B01405A 0B01412A 0B05659A 0B05909A 0B01804A 0B09246A 0B09322A 0B01502A	Fail Safe Type Resistor 150 RDF25S J Carbon Resistor 68K ERD-25V J Carbon Resistor 33K ERD-25V J Mylar Capacitor 1000P 50V J Mylar Capacitor 0.01μ 50V J Electrolytic Capacitor 1μ 50V Electrolytic Capacitor 10μ 16V Mylar Capacitor 5600P 50V J Mylar Capacitor 0.12μ 50V J Mylar Capacitor 3900P 50V J Mica Capacitor 150P 50V J PP Capacitor 330P 100V J Electrolytic Capacitor 330μ 16V	Q114, 214 R172, 272 R173, 273 R174, 274 R175, 275 R176, 276 R177, 279 R177, 179 R178, 278 R180, 280 R181, 281 R182, 281 R182, 282 R184, 284 R340 C157, 257 C158, 258 C159, 259 C160, 260 C161, 261 C334	0B06069A 0B05593A 0B05563A 0B01921A 0B01902A 0B05650A 0B01781A 0B05591A 0B05565A 0B05559A 0B05779A 0B01830A 0B09216A 0B01405A 0B01402A 0B01412A 0B09280A 0B05885A 0B01392A	Transistor 2SB564 Carbon Resistor 150K ERD-25V J Carbon Resistor 56K ERD-25V J Carbon Resistor 330K ERD-25V J Carbon Resistor 68K ERD-25V J Carbon Resistor 12K ERD-25V J Carbon Resistor 1K ERD-25V J Carbon Resistor 15K ERD-25V J Carbon Resistor 1.2K ERD-25V J Carbon Resistor 680 ERD-25V J Carbon Resistor 3.3 ERD-25V J Carbon Resistor 1.8K ERD-25V J Fail Safe Type Resistor 10 RDF25S J Electrolytic Capacitor 1μ 50V Electrolytic Capacitor 4.7μ 25V Electrolytic Capacitor 10μ 16V Ceramic Capacitor 47P 50V J Electrolytic Capacitor 100μ 10V Electrolytic Capacitor 470μ 16V	IC102, 202 R152, 252 R153, 160 R154, 254 R155, 255 R156, 256 R157, 159 R158, 258 R158, 261 R337, 338 C142, 242 C143, 243 C144, 244 C145, 245 C146, 246 C147, 247 C148, 248 C149, 249 C150, 250 C151, 251 C152, 252 C329, 330	-- PB Dolby NR -- 0B06200A IC μA7300PC 0B09241A Carbon Resistor 4.3K ERD-25V J 0B01833A Carbon Resistor 10K ERD-25V J 0B01879A Carbon Resistor 33K ERD-25V J 0B09208A Metal Film Resistor 3.3K SN15K2E F 0B05562A Carbon Resistor 47K ERD-25V J 0B05600A Carbon Resistor 270K ERD-25V J 0B05823A Carbon Resistor 6.2K ERD-25V J 0B05566A Carbon Resistor 2.2K ERD-25V J 0B09213A Fail Safe Type Resistor 150 RDF25S J 0B09223A Electrolytic Capacitor 1μ 50V (LN) 0B01836A Electrolytic Capacitor 47μ 10V 0B01412A Electrolytic Capacitor 10μ 16V 0B09240A PP Capacitor 0.033μ 100V G 0B09191A PP Capacitor 4700P 100V G 0B01862A Electrolytic Capacitor 22μ 16V 0B05583A Mylar Capacitor 0.033μ 50V J 0B01405A Electrolytic Capacitor 1μ 50V 0B01603A Mylar Capacitor 0.1μ 50V K 0B01602A Mylar Capacitor 0.33μ 50V K 0B09257A Electrolytic Capacitor 2200μ 6.3V 0B01398A Electrolytic Capacitor 220μ 16V 0B06201A IC Socket 16P (2 pcs.)		
IC301 L301 VR301 R101, 201 R102, 202 R301, 303 308, 309 R302 R304 R305 R306 R307 R310 R311 R312 R313 R314 C301 C302 C303, 305 C304, 312 C306 C307 C308 C309 C310 C311 C313, 314	0B06124B 0B03563A 0B09093A 0B09205A 0B09206A 0B01920A 0B05672A 0B09269A 0B01789A 0B05562A 0B05661A 0B01921A 0B01833A 0B01879A 0B01857A 0B05623A 0B09275A 0B05687A 0B05681A 0B05832A 0B09235A 0B01780A 0B05652A 0B09323A 0B09045A 0B05685A 0B01412A	IC RC4558D 19K Coil 23mH Semi-fixed Volume 20K Metal Film Resistor 18K SN15K2E F Metal Film Resistor 560K SN15K2E F Carbon Resistor 100K ERD-25V J Carbon Resistor 2.2M ERD-25V J Metal Film Resistor 100K ERD-25VK F Carbon Resistor 330 ERD-25V J Carbon Resistor 47K ERD-25V J Carbon Resistor 22K ERD-25V J Carbon Resistor 330K ERD-25V J Carbon Resistor 10K ERD-25V J Carbon Resistor 33K ERD-25V J Carbon Resistor 1K ERD-25T J Carbon Resistor 1.2K ERD-25T J Mica Capacitor 200P 50V J Mylar Capacitor 1200P 50V J Mylar Capacitor 0.01μ 50V J Mylar Capacitor 0.018μ 50V J PP Capacitor 680P 100V J Mylar Capacitor 0.1μ 50V J Mylar Capacitor 4700P 50V J PP Capacitor 560P 100V J Mylar Capacitor 0.027μ 50V J Mylar Capacitor 0.082μ 50V J Electrolytic Capacitor 10μ 16V	Q301, 302 Q303 T301 L302 R315, 316 R317, 318 R319 R320 R340 C162, 262 C315 C316, 317 C318 C319	0B01872A 0B06202A 0B06613A 0B03861A 0B09212A 0B01564A 0B09295A 0B01877A 0B09296A 0B09284A 0B01402A 0B09191A 0B05583A 0B09254A	Transistor 2SC945 Transistor 2SA562 (Y) Osc. Coil Inductor 1.4mH Fail Safe Type Resistor 2.2 RDF25S J Carbon Resistor 82K ERD-25V J Fail Safe Type Resistor 82 RSF-2B J Carbon Resistor 6.8K ERD-25V J Fail Safe Type Resistor 39 RSF-1/2B J Ceramic Capacitor 270P 50V J Electrolytic Capacitor 4.7μ 25V PP Capacitor 4700P 100V G Mylar Capacitor 0.033μ 50V J PP Capacitor 0.068μ 100V J	IC101, 201 L101, 201 L102, 202 VR101 R103, 105 113, 205 213 R104, 114 204, 214 R106, 206 R107, 207 R108, 208 R109, 209 R110, 112 R110, 112 R111, 211 R203 R321, 322 C101, 201 C102, 202 C103, 203 C104, 204 C105, 205 C106, 108 117, 206 208, 217 323, 324 C107, 207 C109, 209 C110, 210 C111, 116 211, 216 C112, 212 C113, 213 C114, 214 C115, 215 C118, 218 C321, 322	0B06200A IC μA7300PC 0B03919A Inductor 36mH 0B03563A 19K Coil 23mH 0B07178A Semi-fixed Volume 2K 0B05566A Carbon Resistor 2.2K ERD-25V J 0B01833A Carbon Resistor 10K ERD-25V J 0B05673A Carbon Resistor 5.6K ERD-25V J 0B01879A Carbon Resistor 33K ERD-25V J 0B09208A Metal Film Resistor 3.3K SN15K2E F 0B05562A Carbon Resistor 47K ERD-25V J 0B05600A Carbon Resistor 270K ERD-25V J 0B05823A Carbon Resistor 6.2K ERD-25V J 0B01782A Carbon Resistor 2.7K ERD-25V J 0B09213A Fail Safe Type Resistor 150 RDF25S J 0B09223A Electrolytic Capacitor 1μ 50V (LN) 0B01836A Electrolytic Capacitor 47μ 10V 0B09242A Mica Capacitor 47P 50V J 0B09262A PP Capacitor 3000P 50V J 0B01804A Mylar Capacitor 3900P 50V J 0B01412A Electrolytic Capacitor 10μ 16V 0B01913A Mylar Capacitor 1800P 50V J 0B09240A PP Capacitor 0.033μ 100V G 0B09191A PP Capacitor 4700P 100V G 0B01862A Electrolytic Capacitor 22μ 16V 0B01405A Electrolytic Capacitor 1μ 50V 0B05583A Mylar Capacitor 0.033μ 50V J 0B01603A Mylar Capacitor 0.1μ 50V K 0B01602A Mylar Capacitor 0.33μ 50V K 0B09257A Electrolytic Capacitor 2200μ 6.3V 0B01398A Electrolytic Capacitor 220μ 16V	D303 R334 C335 SW301, 304 SW302, 303 SW305 SW306 TP101, 201 0B07815D Main P.C.B. 0B06181A Silicon Diode 1SS53 0B01833A Carbon Resistor 10K ERD-25V J 0B05681A Mylar Capacitor 0.01μ 50V J 0B07262A Rotary Slide Switch A 0B07265A Rotary Slide Switch D 0B07264A Rotary Slide Switch C 0B07263A Rotary Slide Switch B 0B03924A Gate Pin 0B08544A Wrapping Pin 3P (2 pcs.) 0B08545A Wrapping Pin 4P (1 pce.) 0B08547A Wrapping Pin 6P (1 pce.) 0C00037A Earth Lug B-5 (1 pce.) 0B08236A 4P-T Post (2 pcs.) 0B08185A 3P-T Post (1 pce.) 0B08375A 4P-S Post (1 pce.) 0B08334A 8P-T Post (1 pce.) 0B08614A 9P-T Post (1 pce.)				
IC303 Q103, 104 203, 204 Q309 D102, 103 104, 202 203, 204 L103, 104 203, 204 R122, 222 R123, 223 R124, 224 R125, 127 225, 227 R126, 134 228, 234 R128, 132 133, 228 232, 233 R129, 229 R130, 230 R131, 231 R135, 235	0B06146A 0B06070A 0B06013A 0B06181A 0B00068A 0B05591A 0B01877A 0B05558A 0B01920A 0B01833A 0B05661A 0B01795A 0B05688A 0B01830A 0B05663A	IC RC4558DD Transistor 2SC1636 Transistor 2SA733 Silicon Diode 1SS53 Trap Coil 10.5mH Carbon Resistor 15K ERD-25V J Carbon Resistor 6.8K ERD-25V J Carbon Resistor 100 ERD-25V J Carbon Resistor 100K ERD-25V J Carbon Resistor 10K ERD-25V J Carbon Resistor 22K ERD-25V J Carbon Resistor 4.7K ERD-25V J Carbon Resistor 390 ERD-25V J Carbon Resistor 1.8K ERD-25V J Carbon Resistor 10 ERD-25V J	Q108, 109 208, 209 ZD101, 201 D105, 205 D107, 207 VR103, 203 VR104, 204 R162, 262 R163, 263 R164, 167 264, 267 R165, 265 R166, 266 R168, 268 R169, 269 R170, 270 R171, 271 R339 C154, 254 C155, 255 C156, 256 C333	0B06062A 0B06191A 0B06007A 0B06181A 0B07261A 0B03832A 0B05563A 0B01920A 0B01833A 0B09206A 0B09207A 0B01795A 0B05566A 0B05565A 0B01879A 0B09215A 0B01405A 0B09218A 0B09219A 0B01400A	Transistor 2SC1222 Zener Diode 2.7V Silicon Varistor KB-165 Silicon Diode 1SS53 Semi-fixed Volume 20K Semi-fixed Volume 100K Carbon Resistor 56K ERD-25V J Carbon Resistor 100K ERD-25V J Carbon Resistor 10K ERD-25V J Metal Film Resistor 560K SN15K2E F Metal Film Resistor 390K SN15K2E F Carbon Resistor 4.7K ERD-25V J Carbon Resistor 2.2K ERD-25V J Carbon Resistor 1.2K ERD-25V J Carbon Resistor 33K ERD-25V J Fail Safe Type Resistor 100 RDF25S J Electrolytic Capacitor 1μ 50V Electrolytic Capacitor 47μ 16V (LN) Electrolytic Capacitor 6.8μ 16V (LN) Electrolytic Capacitor 100μ 16V	Q110, 210 Q111, 211 Q112, 212 Q113, 213	0B06062A 0B06013A 0B01872A 0B06066A	Transistor 2SC1222 Transistor 2SA733 Transistor 2SC945 Transistor 2SD471	Q111, 211 C321, 322	0B01913A 0B09240A 0B09191A 0B01862A 0B01405A 0B05583A 0B01603A 0B01602A 0B09257A 0B01398A	Myar Capacitor 1800P 50V J PP Capacitor 0.033μ 100V G PP Capacitor 4700P 100V G Electrolytic Capacitor 22μ 16V Electrolytic Capacitor 1μ 50V Mylar Capacitor 0.033μ 50V J Mylar Capacitor 0.1μ 50V K Mylar Capacitor 0.33μ 50V K Electrolytic Capacitor 2200μ 6.3V Electrolytic Capacitor 220μ 16V	-- Meter Amp. -- -- Headphone Amp. --

8.2. Logic P.C.B. Ass'y

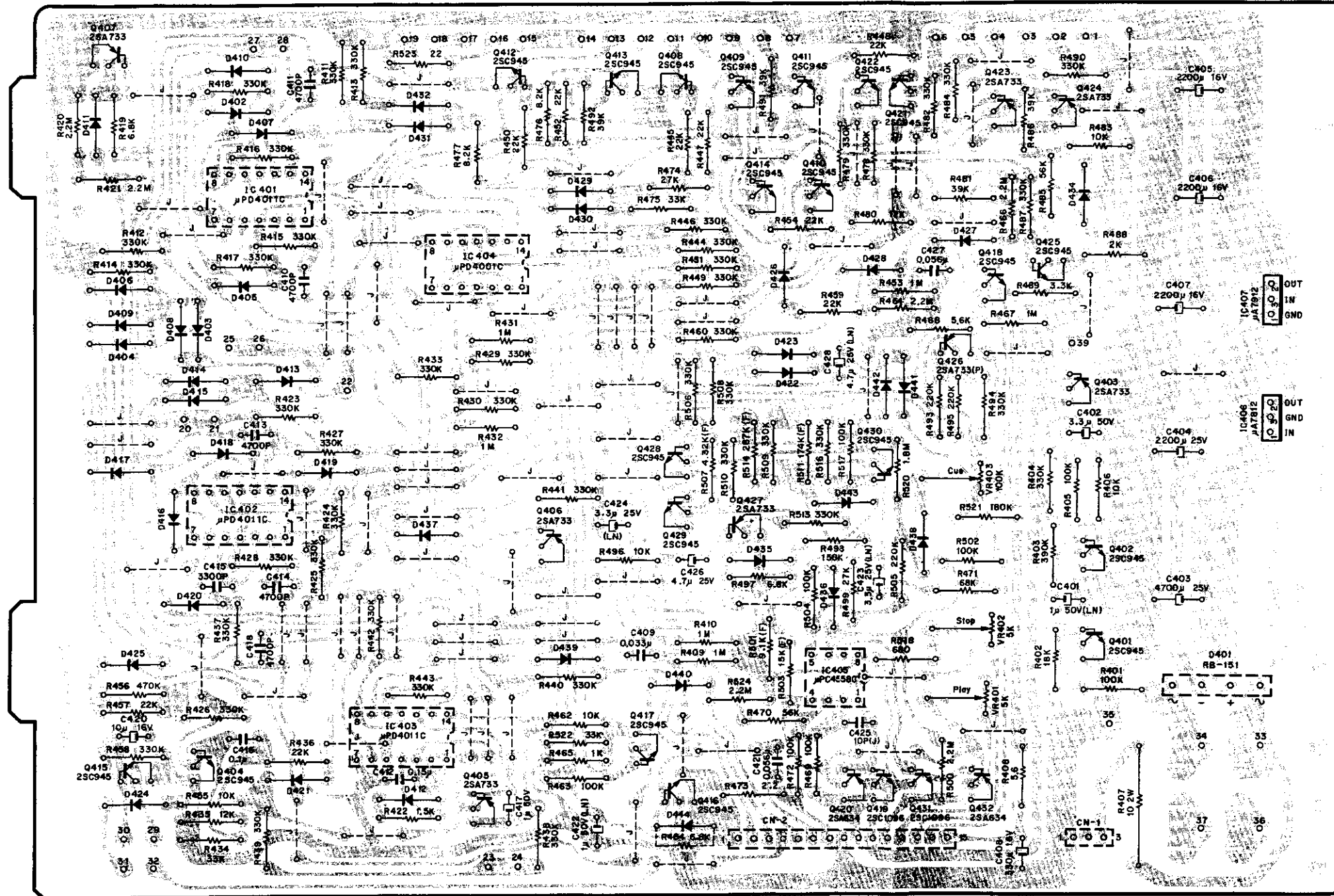

Fig. 8.2.1 Serial No.: A11107951 - Note: Diode is 1SS53, 1S953, or 1S1555 unless otherwise specified.

Schematic Ref. No.	Part No.	Description	Schematic Ref. No.	Part No.	Description	Schematic Ref. No.	Part No.	Description
	BA04073B	Logic P.C.B. Ass'y (U.S.A., Canada & Japan)	R422	0B05698A	Carbon Resistor 1.5K ERD-25T J		0E00037A	Earth Lug B-5 (1 pce.)
	BA04109B	Logic P.C.B. Ass'y (Sweden, Swiss, UK, Germany & Australia) Serial No.: A11107951 -	R434, 475 522	0B05509A	Carbon Resistor 33K ERD-25T J		-	Wrapping Pin (33 pcs.)
			R435, 480	0B09263A	Carbon Resistor 12K ERD-25T J	*	0B08349A	Jumper Wire (85 pcs.)
			R436, 445 447, 448	0B05615A	Carbon Resistor 22K ERD-25T J	*	0B08161U	Fuse Clip (4 pcs.)
			450, 452			*	0M04062A	Fuse 630mAT 250V (2 pcs.)
	0B07841C	Logic P.C.B.	454, 457					Fuse Label 630mAT (1 pce.)
IC401-403	0B06178A	IC $\mu$ PD4011C	459					* included only in Logic P.C.B. Ass'y (BA04109B)
IC404	0B06143A	IC $\mu$ PD4001C	R456	0B01684A	Carbon Resistor 470K ERD-25T J			
IC405	0B06124B	IC $\mu$ PC4558C	R465	0B01857A	Carbon Resistor 1K ERD-25T J			
IC406	0B06192A	Regulator $\mu$ A7812PC	R468	0B01887A	Carbon Resistor 5.6K ERD-25T J			
IC407	0B06193A	Regulator $\mu$ A7912PC	R470, 485	0B05508A	Carbon Resistor 56K ERD-25T J			
Q401, 402 404	0B01872A	Transistor 2SC945 (20 pcs.)	R471	0B05692A	Carbon Resistor 68K ERD-25T J			
408-418			R473	0B09212A	Fail Safe Type Resistor 2.2 RDF-25S J			
421, 422			R474, 499	0B05743A	Carbon Resistor 27K ERD-25T J			
425, 428			R476, 477	0B01856A	Carbon Resistor 8.2K ERD-25T J			
429, 430			R481, 486	0B01854A	Carbon Resistor 39K ERD-25T J			
Q403, 405	0B06013A	Transistor 2SA733 (Q, P)	491, 492					
406, 407			R488	0B09301A	Carbon Resistor 2K ERD-25T J			
423, 424			R489	0B01681A	Carbon Resistor 3.3K ERD-25T J			
427			R493, 495	0B05625A	Carbon Resistor 220K ERD-25T J			
Q419, 431	0B06020A	Transistor 2SC1096	505					
Q420, 432	0B06012A	Transistor 2SA634	R498	0B05626A	Carbon Resistor 150K ERD-25T J			
Q426	0B06155A	Transistor 2SA733 (P)	R501	0B09328A	Metal Film Resistor 9.1K SN15K2E F			
D401	0B06183A	Diode Bridge RB-151	R503	0B09340A	Metal Film Resistor 15K SN15K2E F			
D402-432	0B06181A	Silicon Diode 1SS53 (42 pcs.)	R507	0B09365A	Metal Film Resistor 4.32K SN15K2E F			
434-444			R511	0B09367A	Metal Film Resistor 174K SN15K2E F			
VR401, 402	0B03831A	Semi-fixed Volume 5K	R514	0B09366A	Metal Film Resistor 287K SN15K2E F			
VR403	0B03832A	Semi-fixed Volume 100K	R518	0B05794A	Carbon Resistor 680 ERD-25T J			
R401, 405	0B01889A	Carbon Resistor 100K ERD-25T J	R520	0B05680A	Carbon Resistor 1.8M ERD-25T J			
463, 469			R521	0B05640A	Carbon Resistor 180K ERD-25T J			
472, 502			R523	0B09049A	Fail Safe Type Resistor 22 RDF-25S J			
504, 517			C401, 422	0B09223A	Electrolytic Capacitor 1 $\mu$ 50V (LN)			
R402	0B05560A	Carbon Resistor 18K ERD-25T J	C402	0B01863A	Electrolytic Capacitor 3.3 $\mu$ 50V			
R403	0B05676A	Carbon Resistor 390K ERD-25T J	C403	0B09250A	Electrolytic Capacitor 4700 $\mu$ 25V			
R404	0B05627A	Carbon Resistor 330K ERD-25T J	C404	0B05654A	Electrolytic Capacitor 2200 $\mu$ 25V			
411-418			C405, 406	0B01406A	Electrolytic Capacitor 2200 $\mu$ 16V			
423-430			407					
433			C408	0B01502A	Electrolytic Capacitor 330 $\mu$ 16V			
437-444			C409	0B05513A	Mylar Capacitor 0.033 $\mu$ 50V			
446, 449			C410, 411	0B05556A	Mylar Capacitor 4700P 50V			
451, 458			413, 414					
460, 478			418					
479, 482			C412	0B09171A	Mylar Capacitor 0.15 $\mu$ 50V			
484, 487			C415	0B09166A	Mylar Capacitor 3300P 50V			
490, 494			C416	0B00093A	Mylar Capacitor 0.1 $\mu$ 50V			
506, 508			C417	0B01405A	Electrolytic Capacitor 1 $\mu$ 50V			
509, 510			C420	0B01412A	Electrolytic Capacitor 10 $\mu$ 16V			
513, 516			C421, 427	0B01676A	Mylar Capacitor 0.056 $\mu$ 50V			
R406, 455	0B01888A	Carbon Resistor 10K ERD-25T J	C423, 424	0B09147A	Electrolytic Capacitor 3.3 $\mu$ 25V (LN)			
462, 483			C425	0B09277A	Ceramic Capacitor 10P 50V J			
496			C426	0B01402A	Electrolytic Capacitor 4.7 $\mu$ 25V			
R407	0B09179A	Fail Safe Type Resistor 10 SF2B J	C428	0B09333A	Electrolytic Capacitor 4.7 $\mu$ 25V (LN)			
R408	0B05940A	Fail Safe Type Resistor 5.6 ERD-14F J		0B08579A	15P-S Post (1 pce.)			
R409, 410	0B05776A	Carbon Resistor 1M ERD-25T J		0B08184A	3P-S Post (1 pce.)			
431, 432				0B08568B	Heat Sink A301 (1 pce.)			
453, 467				0B08603A	Mica for Transistor (2 pcs.)			
R419, 464	0B01682A	Carbon Resistor 6.8K ERD-25T J		0B08604A	Bushing for Transistor (2 pcs.)			
497				0E00607A	Screw M3x8 Philips Pan Head (2 pcs.)			
R420, 421	0B05671A	Carbon Resistor 2.2M ERD-25T J		0E00507A	Nut Hex. M3 (2 pcs.)			
461, 466				0E00857A	BT Screw M3x6 Philips Binding Head (2 pcs.)			
500, 524								

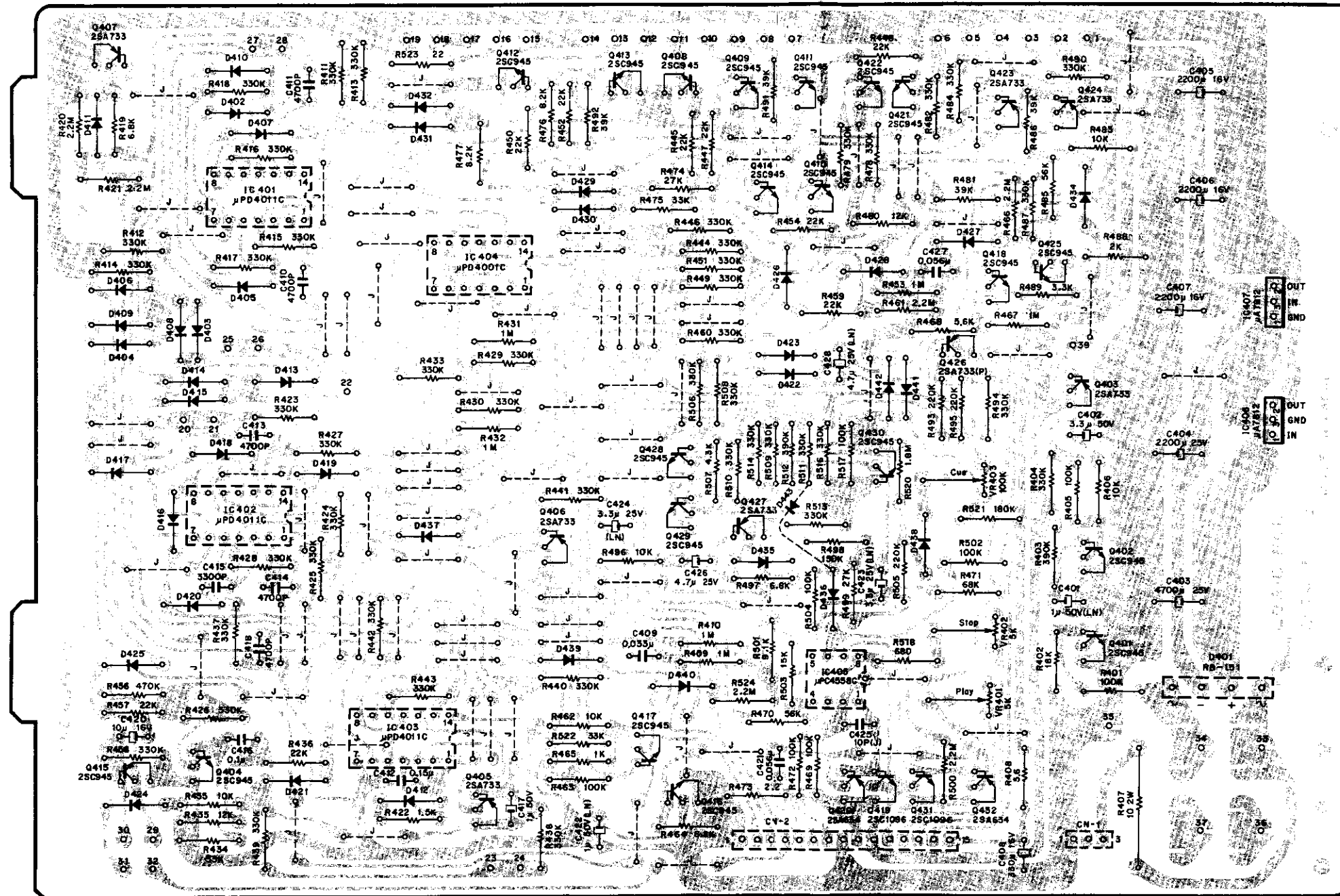

Fig. 8.2.2 Serial Nos.: A11105952 – A11107950

Note: Diode is 1S553, 1S953, or 1S1555 unless otherwise specified.

Schematic Ref. No.	Part No.	Description	Schematic Ref. No.	Part No.	Description	Schematic Ref. No.	Part No.	Description
	BA04073A	Logic P.C.B. Ass'y (U.S.A., Canada & Japan)	R420, 421	0B05671A	Carbon Resistor 2.2M ERD-25T J		0E00037A	Earth Lug B-5 (1 pce.)
	BA04109A	Logic P.C.B. Ass'y (Sweden, Swiss, UK, Germany & Australia) Serial Nos.: A11105952 - A11107950	461, 466 500, 524				-	Wrapping Pin (33 pcs.)
			R422	0B05698A	Carbon Resistor 1.5K ERD-25T J	*	0B08349A	Jumper Wire (85 pcs.)
			R434, 475	0B05509A	Carbon Resistor 33K ERD-25T J	*	0B08161U	Fuse Clip (4 pcs.)
			522			*	0M04062A	Fuse 630mAT 250V (2 pcs.)
	0B07841B	Logic P.C.B.	R435, 480	0B09263A	Carbon Resistor 12K ERD-25T J			Fuse Label 630mAT (1 pce.)
IC401-403	0B06178A	IC $\mu$ PD4011C	R436, 445	0B05615A	Carbon Resistor 22K ERD-25T J			
IC404	0B06143A	IC $\mu$ PD4001C	447, 448					
IC405	0B06124B	IC $\mu$ PC4558C	450, 452					
IC406	0B06192A	Regulator $\mu$ A7812PC	454, 457					
IC407	0B06193A	Regulator $\mu$ A7912PC	459					
Q401, 402	0B01872A	Transistor 2SC945 (20 pcs.)	R456	0B01684A	Carbon Resistor 470K ERD-25T J			
404			R465	0B01857A	Carbon Resistor 1K ERD-25T J			
408-418			R468	0B01887A	Carbon Resistor 5.6K ERD-25T J			
421, 422			R470, 485	0B05508A	Carbon Resistor 56K ERD-25T J			
425, 428			R471	0B05692A	Carbon Resistor 68K ERD-25T J			
429, 430			R473	0B09212A	Fail Safe Type Resistor 2.2 RDF-25S J			
Q403, 405	0B06013A	Transistor 2SA733 (Q, P)	R474, 499	0B05743A	Carbon Resistor 27K ERD-25T J			
406, 407			R476, 477	0B01856A	Carbon Resistor 8.2K ERD-25T J			
423, 424			R481, 486	0B01854A	Carbon Resistor 39K ERD-25T J			
427			491, 492					
Q419, 431	0B06020A	Transistor 2SC1096	R488	0B09301A	Carbon Resistor 2K ERD-25T J			
Q420, 432	0B06012A	Transistor 2SA634	R489	0B01681A	Carbon Resistor 3.3K ERD-25T J			
Q426	0B06155A	Transistor 2SA733 (P)	R493, 495	0B05625A	Carbon Resistor 220K ERD-25T J			
D401	0B06183A	Diode Bridge RB-151	505					
D402-432	0B06181A	Silicon Diode 1SS53 (41 pcs.)	R498	0B05626A	Carbon Resistor 150K ERD-25T J			
434-443			R501	0B09226A	Carbon Resistor 9.1K ERD-25T J			
VR401, 402	0B03831A	Semi-fixed Volume 5K	R503	0B01683A	Carbon Resistor 15K ERD-25T J			
VR403	0B03832A	Semi-fixed Volume 100K	R507	0B09307A	Carbon Resistor 4.3K ERD-25T J			
R401, 405	0B01889A	Carbon Resistor 100K ERD-25T J	R518	0B05794A	Carbon Resistor 680 ERD-25T J			
463, 469			R520	0B05680A	Carbon Resistor 1.8M ERD-25T J			
472, 502			R521	0B05640A	Carbon Resistor 180K ERD-25T J			
504, 517			R523	0B09049A	Fail Safe Type Resistor 22 RDF-25S J			
R402	0B05560A	Carbon Resistor 18K ERD-25T J	C401, 422	0B09223A	Electrolytic Capacitor 1 $\mu$ 50V (LN)			
R403, 512	0B05676A	Carbon Resistor 390K ERD-25T J	C402	0B01863A	Electrolytic Capacitor 3.3 $\mu$ 50V			
R404	0B05627A	Carbon Resistor 330K ERD-25T J	C403	0B09250A	Electrolytic Capacitor 4700 $\mu$ 25V			
411-418			C404	0B05654A	Electrolytic Capacitor 2200 $\mu$ 25V			
423-430			C405, 406	0B01406A	Electrolytic Capacitor 2200 $\mu$ 16V			
433			407					
437-444			C408	0B01502A	Electrolytic Capacitor 330 $\mu$ 16V			
446, 449			C409	0B05513A	Mylar Capacitor 0.033 $\mu$ 50V			
451, 458			C410, 411	0B05556A	Mylar Capacitor 4700P 50V			
460, 478			413, 414					
479, 482			418					
484, 487			C412	0B09171A	Mylar Capacitor 0.15 $\mu$ 50V			
490, 494			C415	0B09166A	Mylar Capacitor 3300P 50V			
506, 508			C416	0B00093A	Mylar Capacitor 0.1 $\mu$ 50V			
509, 510			C417	0B01405A	Electrolytic Capacitor 1 $\mu$ 50V			
511, 513			C420	0B01412A	Electrolytic Capacitor 10 $\mu$ 16V			
514, 516			C421, 427	0B01676A	Mylar Capacitor 0.056 $\mu$ 50V			
R406, 455	0B01888A	Carbon Resistor 10K ERD-25T J	C423, 424	0B09147A	Electrolytic Capacitor 3.3 $\mu$ 25V (LN)			
462, 483			C425	0B09277A	Ceramic Capacitor 10P 50V J			
496			C426	0B01402A	Electrolytic Capacitor 4.7 $\mu$ 25V			
R407	0B09179A	Fail Safe Type Resistor 10 SF28 J	C428	0B09333A	Electrolytic Capacitor 4.7 $\mu$ 25V (LN)			
R408	0B05940A	Fail Safe Type Resistor 5.6 ERD-14F J		0B08579A	15P-S Post (1 pce.)			
R409, 410	0B05776A	Carbon Resistor 1M ERD-25T J		0B08184A	3P-S Post (1 pce.)			
431, 432				0B08568B	Heat Sink A301 (1 pce.)			
453, 467				0B08603A	Mica for Transistor (2 pcs.)			
R419, 464	0B01682A	Carbon Resistor 6.8K ERD-25T J		0B08604A	Bushing for Transistor (2 pcs.)			
497				0E00607A	Screw M3x8 Philips Pan Head (2 pcs.)			
				0E00507A	Nut Hex. M3 (2 pcs.)			
				0E00857A	BT Screw M3x6 Philips Binding Head (2 pcs.)			

\* included only in Logic P.C.B. Ass'y (BA04109A)

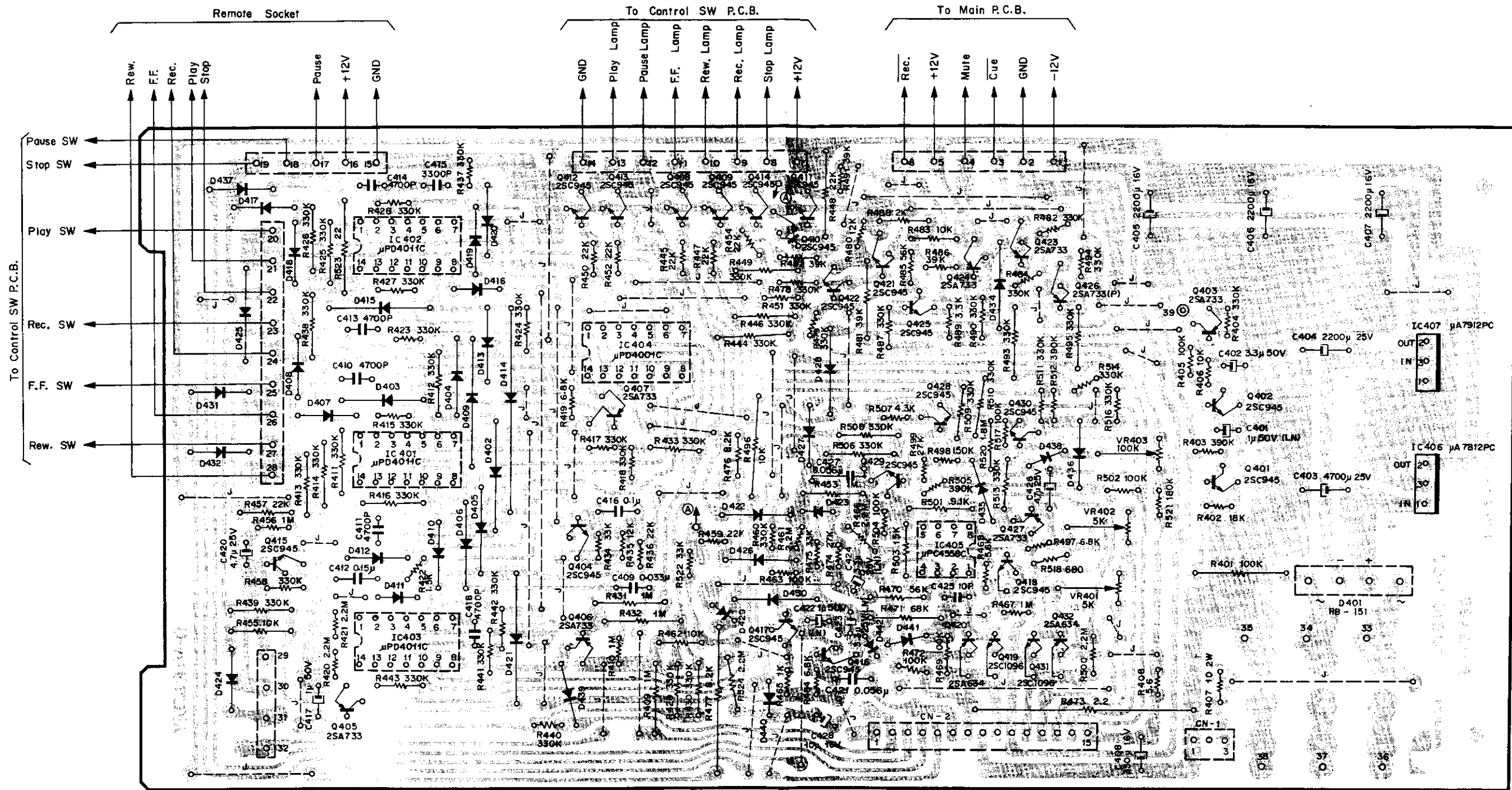

Fig. 8.2.3 Serial Nos.: A11101001 – A11105951

Note: Diode is 1SS53, 1S953, or 1S1555 unless otherwise specified.

8.3. Lamp P.C.B. Ass'y



Fig. 8.3



Schematic Ref. No.	Part No.	Description	Schematic Ref. No.	Part No.	Description	Schematic Ref. No.	Part No.	Description
	BA04036B	Logic P.C.B. Ass'y (U.S.A., Canada & Japan)	R411, 412	0B05627A	Carbon Resistor 330K ERD-25T J	C423, 424	0B09147A	Electrolytic Capacitor 3.3μ 25V (LN)
	BA04040A	Logic P.C.B. Ass'y (Sweden, Swiss, UK, Germany & Australia) Serial Nos.: A11101001 - A11105951	413, 414 416, 425 426, 438 439, 444 446, 449 493, 495			C425 C428	0B09277A 0B01412A	Ceramic Capacitor 10P 50V J Electrolytic Capacitor 10μ 16V
	0B07799C	Logic P.C.B.	506, 508				0B08542A	Wrapping Pin 1P (1 pce.)
IC401-403	0B06178A	IC μPD4011C (3 pcs.)	509, 510	0B01877A	Carbon Resistor 6.8K ERD-25V J		0B08545A	Wrapping Pin 4P (1 pce.)
IC404	0B06143A	IC μPD4001C	R419, 464	0B05672A	Carbon Resistor 2.2M ERD-25V J		0B08546A	Wrapping Pin 5P (1 pce.)
IC405	0B06124B	IC μPC4558C	497				0B08547A	Wrapping Pin 6P (1 pce.)
IC406	0B06192A	Regulator μA7812PC	R420, 421				0B08549A	Wrapping Pin 8P (1 pce.)
IC407	0B06193A	Regulator μA7912PC	461, 466				0B08550A	Wrapping Pin 9P (1 pce.)
Q401, 402	0B01872A	Transistor 2SC945 (20 pcs.)	500, 524				0B08184A	3P-S Post (1 pce.)
408-418			R422	0B05505A	Carbon Resistor 1.5K ERD-25V J		0B08579A	15P-S Post (1 pce.)
421, 422			R434, 475	0B01879A	Carbon Resistor 33K ERD-25V J		0B08568B	Heat Sink A301 (1 pce.)
425, 428			522				0E00607A	Screw M3x8 Philips Pan Head (3A) (2 pcs.)
429, 430			R435, 480	0B05650A	Carbon Resistor 12K ERD-25V J		0E00507A	Nut Hex. M3 (2 pcs.)
Q403, 405	0B06013A	Transistor 2SA733 (Q, P)	R436, 445	0B05661A	Carbon Resistor 22K ERD-25V J		0E00857A	BT Screw M3x6 Philips Binding Head (2 pcs.)
406, 407			447, 450					
423, 424			452, 454					
427			457, 459					
Q419, 431	0B06020A	Transistor 2SC1096	R448	0B05615A	Carbon Resistor 22K ERD-25T J		0E00037A	Earth Lug B-5 (1 pce.)
Q420, 432	0B06012A	Transistor 2SA634	R455, 496	0B01888A	Carbon Resistor 10K ERD-25T J		0B08603A	Mica for Transistor (2 pcs.)
Q426	0B06155A	Transistor 2SA733 (P)	R465	0B01781A	Carbon Resistor 1K ERD-25V J		0B08604A	Bushing for Transistor (2 pcs.)
D401	0B06183A	Diode Bridge RB-151	R468	0B05673A	Carbon Resistor 5.6K ERD-25V J		0B08349A	Fuse Clip (4 pcs.)
D402-432	0B06181A	Silicon Diode 1SS53 (40 pcs.)	R470, 485	0B05663A	Carbon Resistor 56K ERD-25V J		0B08161U	Fuse 630mAT 250V (2 pcs.)
434-442			R471	0B05692A	Carbon Resistor 68K ERD-25T J		0M04062A	Fuse Label 630mAT (1 pce.)
VR401,402	0B03831A	Semi-fixed Volume 5K	R473	0B09212A	Fail Safe Type Resistor 2.2 RDF25S J			* included only in Logic P.C.B. Ass'y (BA04040A)
VR403	0B03832A	Semi-fixed Volume 100K	R474, 499	0B05538A	Carbon Resistor 27K ERD-25V J	PL001,002	0B07801A	Lamp P.C.B.
R401	0B01889A	Carbon Resistor 100K ERD-25T J	R476	0B01878A	Carbon Resistor 8.2K ERD-25V J	003	0B08553A	Lamp 14V 80mA
R402	0B05561A	Carbon Resistor 18K ERD-25V J	R477	0B01856A	Carbon Resistor 8.2K ERD-25T J	CN1	0B08575A	3P-H Connector A301
R403, 505	0B05595A	Carbon Resistor 390K ERD-25V J	R481	0B01854A	Carbon Resistor 39K ERD-25T J			
512			R486, 491	0B01885A	Carbon Resistor 39K ERD-25V J			
R404, 415	0B01921A	Carbon Resistor 330K ERD-25V J	492					
417, 418			R488	0B09168A	Carbon Resistor 2K ERD-25V J			
423, 424			R489	0B01793A	Carbon Resistor 3.3K ERD-25V J			
427, 428			R498	0B05593A	Carbon Resistor 150K ERD-25V J			
429, 430			R501	0B09226A	Carbon Resistor 9.1K ERD-25T J			
433, 437			R503	0B05591A	Carbon Resistor 15K ERD-25V J			
440, 441			R507	0B09225A	Carbon Resistor 4.3K ERD-25V J			
442, 443			R518	0B05559A	Carbon Resistor 680 ERD-25V J			
451, 458			R520	0B05670A	Carbon Resistor 1.8M ERD-25V J			
460, 478			R521	0B05669A	Carbon Resistor 180K ERD-25V J			
479, 482			R523	0B09049A	Fail Safe Type Resistor 22 RDF25S J			
484, 487			C401, 422	0B09223A	Electrolytic Capacitor 1μ 50V (LN)			
490, 494			C402	0B01863A	Electrolytic Capacitor 3.3μ 50V			
511, 513			C403	0B09250A	Electrolytic Capacitor 4700μ 25V			
514, 516			C404	0B05654A	Electrolytic Capacitor 2200μ 25V			
R405, 463	0B01920A	Carbon Resistor 100K ERD-25V J	C405, 406	0B01406A	Electrolytic Capacitor 2200μ 16V			
469, 472			407					
502, 504			C408	0B01502A	Electrolytic Capacitor 330μ 16V			
517			C409	0B05513A	Mylar Capacitor 0.033μ 50V			
R406, 462	0B01833A	Carbon Resistor 10K ERD-25V J	C410, 411	0B05556A	Mylar Capacitor 4700P 50V			
483			413, 414					
R407	0B09160A	Fail Safe Type Resistor 10 RSF2B J	418					
R408	0B05940A	Fail Safe Type Resistor 5.6 ERD-14F J	C412	0B09171A	Mylar Capacitor 0.15μ 50V			
R409, 431	0B05776A	Carbon Resistor 1M ERD-25T J	C415	0B09166A	Mylar Capacitor 3300P 50V			
432, 453			C416	0B00093A	Mylar Capacitor 0.1μ 50V			
R410, 456	0B05564A	Carbon Resistor 1M ERD-25V J	C417	0B01405A	Electrolytic Capacitor 1μ 50V			
467			C420, 426	0B01402A	Electrolytic Capacitor 4.7μ 25V			
			C421, 427	0B01676A	Mylar Capacitor 0.056μ 50V			

8.4. Control Switch P.C.B. Ass'y

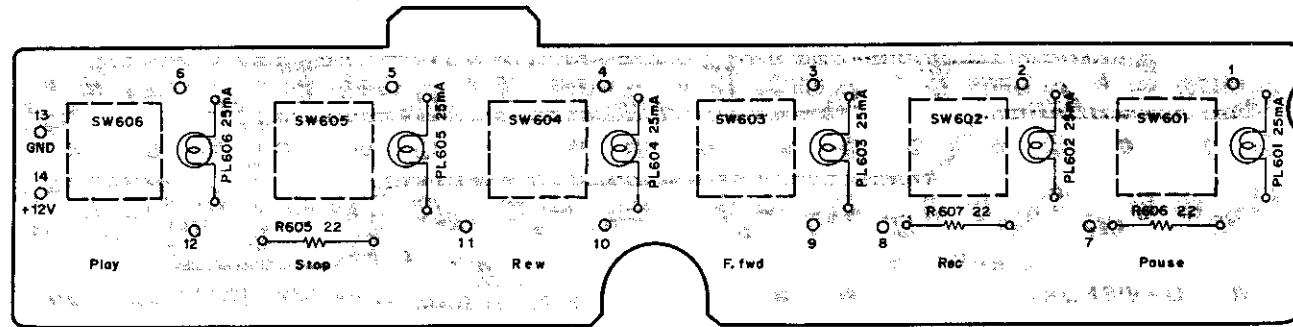

Fig. 8.4

8.5. Volume P.C.B. Ass'y

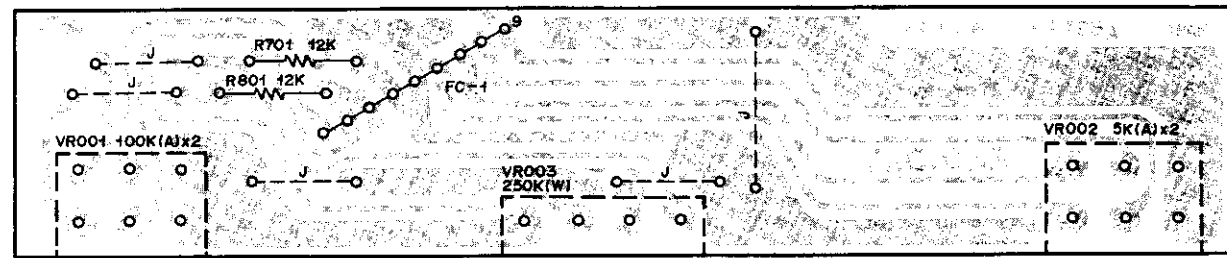

Fig. 8.5

8.6. DIN-Pin P.C.B. Ass'y

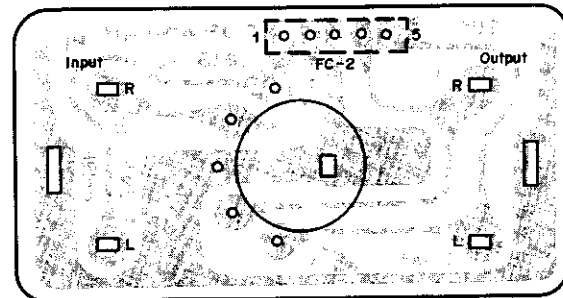

Fig. 8.6

Schematic Ref. No.	Part No.	Description	Schematic Ref. No.	Part No.	Description
	BA03976A	Control Switch P.C.B. Ass'y		BA04013A	Volume P.C.B. Ass'y
R605,606 607	OB07798A OB09049A	Control Switch P.C.B. Fail Safe Type Resistor 22 RBF25S J	VR001	OB07795A	Volume P.C.B.
PL601,602 603,604 605,606	OB08552A	Lamp 12V 25mA	VR002	OB07231A	Volume 100K (A) x 2
SW601,602 603,604 605,606	OB07254A	Switch EVQ-P1R04K	VR003	OB07259A	Volume 5K (A) x 2
	OB08567B	Lamp Holder (6 pcs.)	R701,801 FC1	OB07255A	Volume 250K (W)
				OB05771A	Carbon Resistor 12K ERD-25T J
				OB05229A	Flat Cable D
				QJ03973B	Volume Holder A301 (1 pcs.)
				BA04031A	DIN-Pin P.C.B. Ass'y
			FC2	OB07816A	DIN-Pin Jack P.C.B.
				OB05226A	Flat Cable
				OB08097A	Jack Unit (1 pcs.)
				OE00037A	Earch Lug B-5 (1 pcs.)

8.7. Shut-off P.C.B. Ass'y

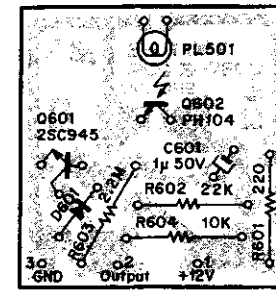

Fig. 8.7.1

Serial No.: A11106110 -

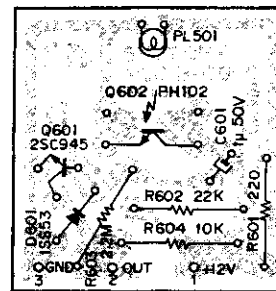

Fig. 8.7.2

Serial Nos.: A11101001 -  
A11106109

8.8. Record Cal. P.C.B. Ass'y

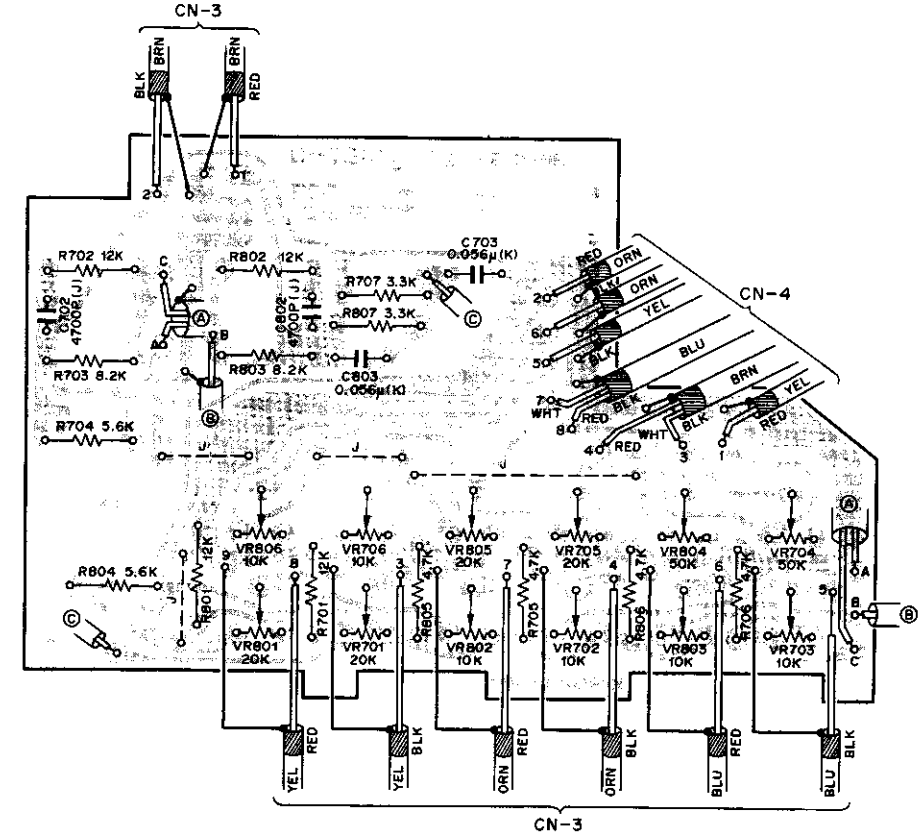

Fig. 8.8

Schematic Ref. No.	Part No.	Description	Schematic Ref. No.	Part No.	Description
	BA04076A	Shut-off Sensor P.C.B. Ass'y Serial No.: A11106110 -		BA04014A	Record Calibration P.C.B. Ass'y
Q601	OB07800B	Shut-off Sensor P.C.B.	VR701,705	OB07813C	Record Calibration P.C.B.
Q602	OB01872A	Transistor 25C945	801,805	OB07270A	Semi-fixed Volume 20K
D601	OB06228A	Photo Transistor PH104	VR702,703	OB07256A	Semi-fixed Volume 10K
R601	OB06181A	Silicon Diode 1SS53	706,802		
R602	OB01933A	Carbon Resistor 220 ERD-25T J	803,806		
R603	OB05615A	Carbon Resistor 22K ERD-25T J	VR704,804	OB07269A	Semi-fixed Volume 50K
R604	OB05671A	Carbon Resistor 2.2M ERD-25T J	R701,702	OB05771A	Carbon Resistor 12K ERD-25T J
R604	OB01888A	Carbon Resistor 10K ERD-25T J	801,802		
C601	OB01405A	Electrolytic Capacitor 1μ 50V	R703,803	OB01856A	Carbon Resistor 8.2K ERD-25T J
PL501	OB08552A	Lamp 12V 25mA	R704, 804	OB01887A	Carbon Resistor 5.6K ERD-25T J
			R705,706	OB01846A	Carbon Resistor 4.7K ERD-25T J
	BA03975A	Shut-off Sensor P.C.B. Ass'y Serial Nos.: A11101001 - A11106109	805,806		
Q601	OB07800B	Shut-off Sensor P.C.B.	R707,807	OB01681A	Carbon Resistor 3.3K ERD-25T J
Q602	OB01872A	Transistor 25C945	C702,802	OB05652A	Mylar Capacitor 4700P 50V J
D601	OB06182A	Photo Transistor PH102	C703,803	OB09274A	Ceramic Capacitor 0.056μ 25V K
R601	OB06181A	Silicon Diode 1SS53	CN3	OB08617B	9P-H Connector A302
R602	OB01933A	Carbon Resistor 220 ERD-25T J	CN4	OB08616B	8P-H Connector A302
R603	OB05615A	Carbon Resistor 22K ERD-25T J			
R604	OB05671A	Carbon Resistor 2.2M ERD-25T J			
R604	OB01888A	Carbon Resistor 10K ERD-25T J			
C601	OB01405A	Electrolytic Capacitor 1μ 50V			
PL501	OB08552A	Lamp 12V 25mA			
	OC08108A	Photo Transistor Terminal (2 pcs.)			

9. MECHANISM ASS'Y AND PARTS LIST

9.1. Synthesis

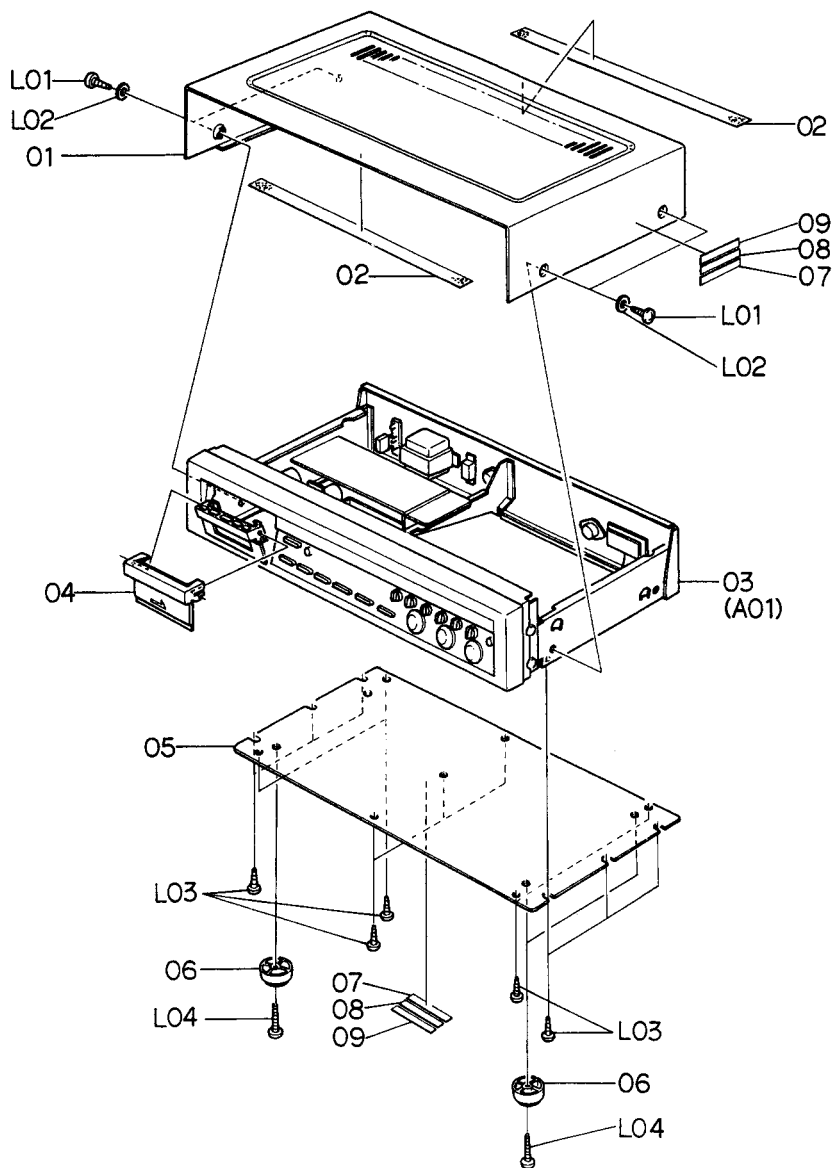

Fig. 9.1

Schematic Ref. No.	Part No.	Description	Q'ty	Schematic Ref. No.	Part No.	Description	Q'ty
		<b>Synthesis</b>		05	0J03972B	Bottom Cover	1
01	0H03681C	Top Cover	1	06	0J03825A	Leg S	4
02	0H03580B	Top Cover Himelon	2	07	0M03799A	Caution Label G	2
03	JA03459A	Synthesis Mechanism 582 (U.S.A. & Canada)	1	08	0M03800A	Caution Label H	2
	JA03460A	Synthesis Mechanism 582 (Japan)	1	09	0M03883A	Lamp Caution Label	2
	JA03462A	Synthesis Mechanism 582 (Others)	1	L01	0E00858A	BT Screw M4x6 Philips Binding Head (Black)	4
	JA03464A	Synthesis Mechanism 582 (UK)	1	L02	0E00736A	Washer 4mm (Black)	4
	JA03514A	Synthesis Mechanism 582 (220V Class 2)	1	L03	0E00857A	BT Screw M3x6 Philips Binding Head	13
	JA03624A	Synthesis Mechanism 582 (Australia)	1	L04	0E00852A	BT Screw M4x12 Philips Binding Head	4
04	0H03689B	Acrylic Cassette Compartment Cover	1				

Schematic Ref. No.	Part No.	Description	Q'ty	Schematic Ref. No.	Part No.	Description	Q'ty	
A01	JA03459A	Synthesis Mechanism 582 (U.S.A. & Canada)	1	B01	HA03813A	Front Panel Ass'y 581 Serial No.: A11106310 —	1	
	JA03460A	Synthesis Mechanism 582 (Japan)	1		01	HA03776A	Meter Ass'y	1
	JA03462A	Synthesis Mechanism 582 (Others)	1		02	HA03777A	Lamp House Cover Ass'y	1
	JA03464A	Synthesis Mechanism 582 (UK)	1		03	0H03697A	Aluminum Mirror	1
	JA03514A	Synthesis Mechanism 582 (220V Class 2)	1		04	0J03979B	Flange Holder	1
	JA03624A	Synthesis Mechanism 582 (Australia) Serial No.: A11105921 —	1		05	HA03803A	Push Button Ass'y A	1
01	0H03706A	Volume Knob	3	06	HA03805A	Push Button Ass'y C	1	
02	0H03712C	Switch Knob	6	07	HA03806A	Counter Reset Button Ass'y	1	
03	HA03813A	Front Panel Ass'y 582	1	08	0J03965C	Control Button Shaft Holder	1	
04	JA03390A	Headphone Jack Ass'y	1	09	0J03986B	Control Button Spring	1	
05	CA08051B	Mechanism Ass'y 582	1	10	0J03966A	Control Button Shaft	1	
06	JA03477B	Chassis Ass'y 582 (U.S.A. & Canada)	1	11	HA03810A	Control Button A Ass'y	1	
	JA03478B	Chassis Ass'y 582 (Japan)	1	12	HA03811A	Control Button B Ass'y	5	
	JA03480B	Chassis Ass'y 582 (Others)	1	13	HA03796D	Front Panel Sub Ass'y	1	
	JA03482B	Chassis Ass'y 582 (UK)	1	L01	0E00793A	BT Screw M2x6 Philips Pan Head	5	
	JA03516B	Chassis Ass'y 582 (220V Class 2)	1	L02	0E00840A	BT Screw M2x8 Philips Pan Head	1	
	JA03625B	Chassis Ass'y 582 (Australia)	1	L03	0E00100A	Washer 2mm	1	
L01	0E00877A	ST Screw M3x5 Philips Binding Head	6	L04	0E00873A	BT Screw M2.6x5 Philips Binding Head	3	
L02	0E00857A	BT Screw M3x6 Philips Binding Head	1	L05	0E00841A	BT Screw M2x4 Philips Pan Head	4	
L03	0E00867A	BT Screw M4x15 Philips Binding Head	3	L06	0E00794A	BT Screw M2x5 Philips Pan Head	3	
L04	0E00878A	BT Screw M4x20 Philips Binding Head	1	B01	HA03794A	Front Panel Ass'y Serial Nos.: A11101001 — A11106309	1	
A01	JA03459A	Synthesis Mechanism 582 (U.S.A. & Canada)	1	01	HA03776A	Meter Ass'y	1	
	JA03460A	Synthesis Mechanism 582 (Japan)	1	02	HA03777A	Lamp House Cover Ass'y	1	
	JA03462A	Synthesis Mechanism 582 (Others)	1	03	0H03697A	Aluminum Mirror	1	
	JA03464A	Synthesis Mechanism 582 (UK)	1	04	0J03979B	Flange Holder	1	
	JA03514A	Synthesis Mechanism 582 (220V Class 2)	1	05	HA03803A	Push Button Ass'y A	1	
	JA03624A	Synthesis Mechanism 582 (Australia) Serial Nos.: A11101001 — A11105920	1	06	HA03805A	Push Button Ass'y C	1	
01	0H03706A	Volume Knob	3	07	HA03806A	Counter Reset Button Ass'y	1	
02	0H03712C	Switch Knob	6	08	0J03965C	Control Button Shaft Holder	1	
03	HA03813A	Front Panel Ass'y 582	1	09	0J03986B	Control Button Spring	1	
04	JA03390A	Headphone Jack Ass'y	1	10	0J03966A	Control Button Shaft	1	
05	CA08051B	Mechanism Ass'y 582	1	11	HA03797A	Control Button A Ass'y	1	
06	JA03477A	Chassis Ass'y 582 (U.S.A. & Canada)	1	12	HA03798A	Control Button B Ass'y	5	
	JA03478A	Chassis Ass'y 582 (Japan)	1	13	HA03796D	Front Panel Sub Ass'y	1	
	JA03480A	Chassis Ass'y 582 (Others)	1	L01	0E00793A	BT Screw M2x6 Philips Pan Head	5	
	JA03482A	Chassis Ass'y 582 (UK)	1	L02	0E00840A	BT Screw M2x8 Philips Pan Head	1	
	JA03516A	Chassis Ass'y 582 (220V Class 2)	1	L03	0E00100A	Washer 2mm	1	
	JA03625A	Chassis Ass'y 582 (Australia)	1	L04	0E00873A	BT Screw M2.6x5 Philips Binding Head	3	
L01	0E00877A	ST Screw M3x5 Philips Binding Head	6	L05	0E00841A	BT Screw M2x4 Philips Pan Head	4	
L02	0E00857A	BT Screw M3x6 Philips Binding Head	1	L06	0E00794A	BT Screw M2x5 Philips Pan Head	3	
L03	0E00867A	BT Screw M4x15 Philips Binding Head	3	B02	JA03390A	Headphone Jack Ass'y	1	
L04	0E00878A	BT Screw M4x20 Philips Binding Head	1	01	0B08511A	Headphone Jack	1	
				02	0J03975A	Jack Holder	1	
				L01	—	Jack Nut	(1)	
				L02	—	Jack Washer	(1)	

9.2. Synthesis Mechanism 582 (A01)

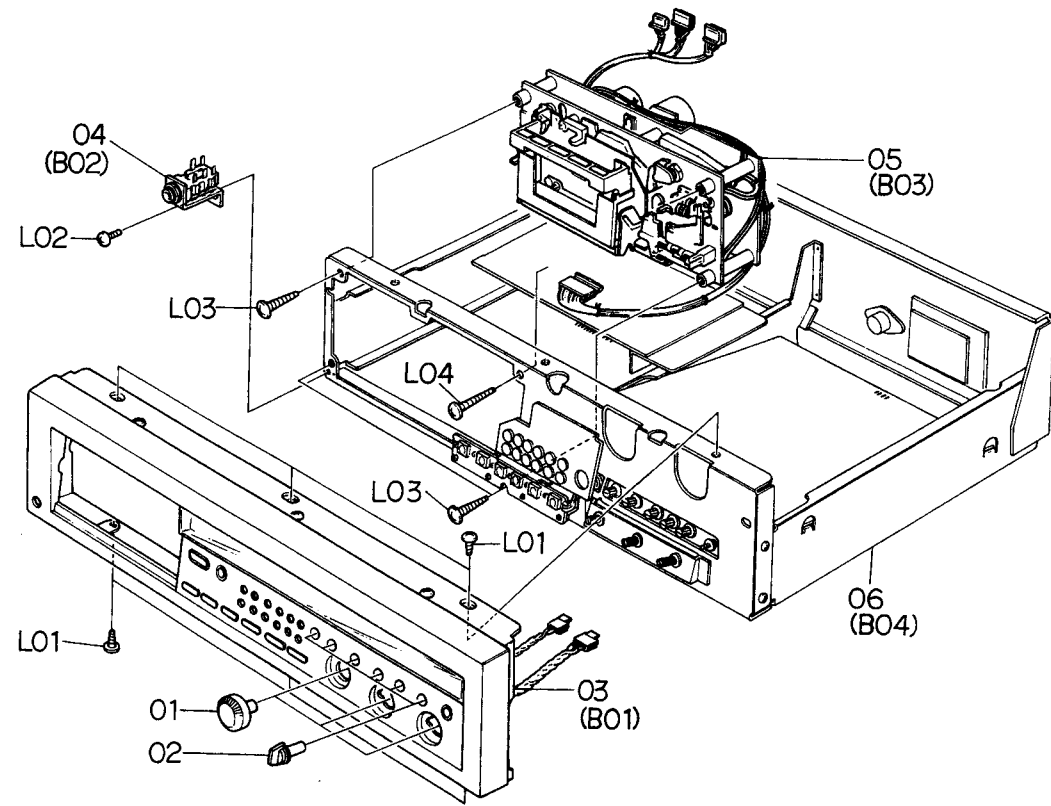

Fig. 9.2

9.3. Front Panel Ass'y 582 (B01)

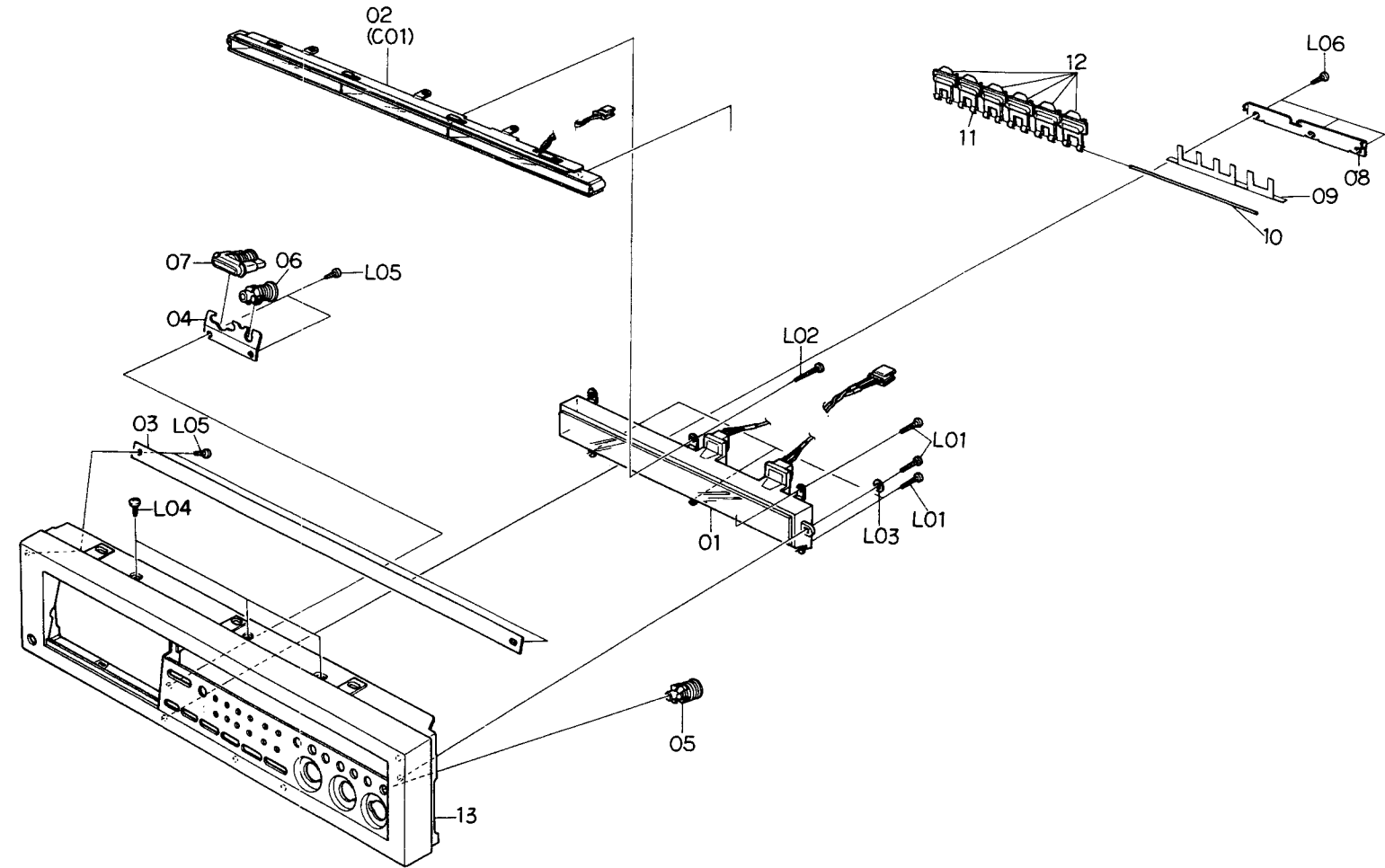

Fig. 9.3

9.4. Headphone Jack Ass'y (B02)

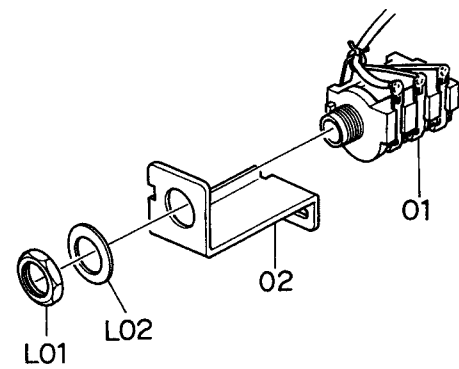

Fig. 9.4

9.5. Mechanism Ass'y 582 (B03)

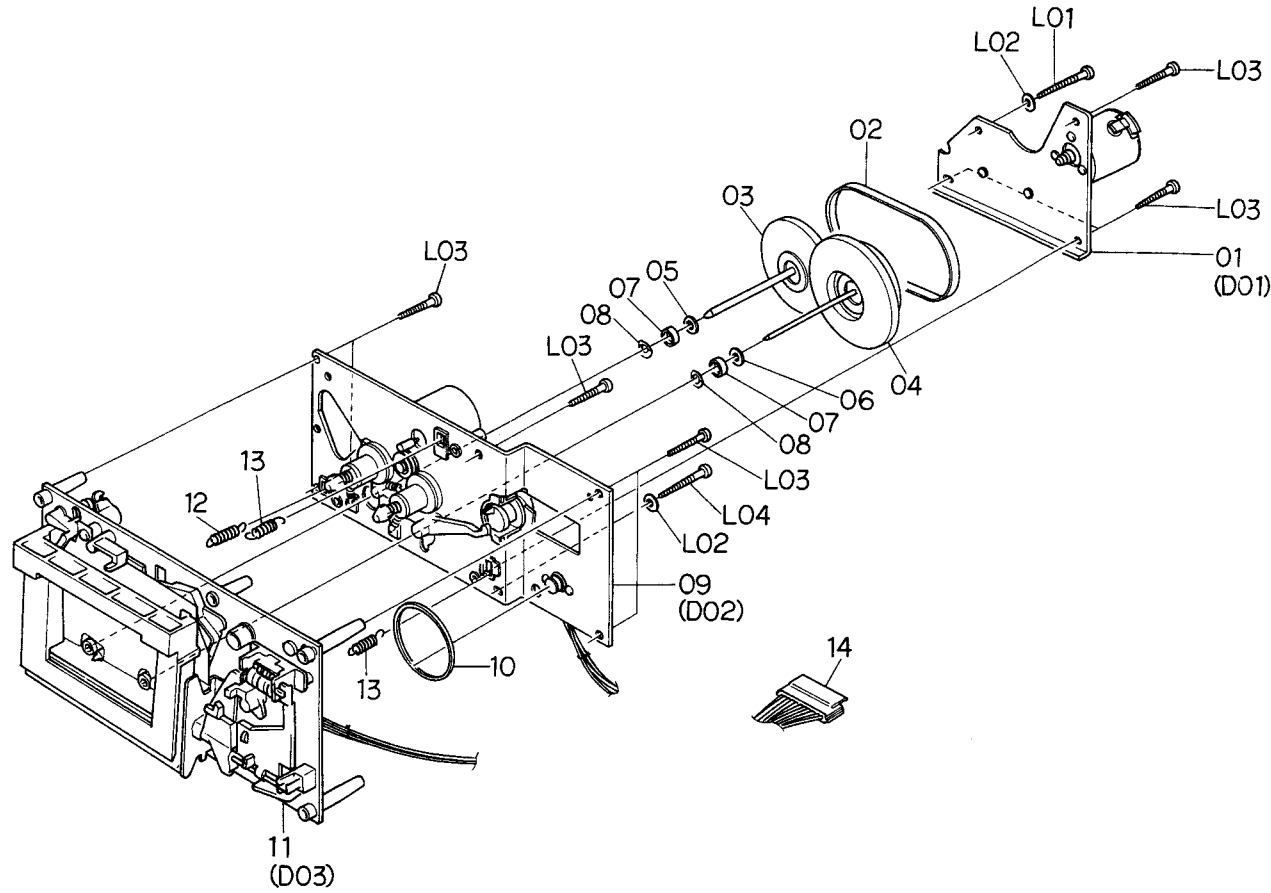

Fig. 9.5

Schematic Ref. No.	Part No.	Description	Q'ty
<b>B03</b>	<b>CA08051B</b>	<b>Mechanism Ass'y 582</b>	<b>1</b>
01	CA08017B	Flywheel Holder Ass'y	1
02	0C08096C	Capstan Belt	1
03	CA08014A	Supply Flywheel Ass'y	1
04	CA08015A	Take-up Flywheel Ass'y	1
05	0C08021B	Thrust Washer 3.1mm	1
06	0C08020B	Thrust Washer 2.6mm	1
07	0C08069C	Flange Thrust Cap	2
08	0C08022B	Flange Thrust Spring	2
09	CA08065A	Sub Mechanism Chassis Ass'y	1
10	0C08099B	Control Motor Belt	1
11	CA08078B	Main Mechanism Chassis Ass'y	1
12	0C08175A	Head Base L Spring	1
13	0C08113A	Head Base Spring	2
14	0B08578C	15P-H Connector	1
L01	0E00834A	BT Screw M3x30 Philips Pan Head	1
L02	0E00178A	Washer 3mm	2
L03	0E00833A	BT Screw M3x20 Philips Pan Head	8
L04	0E00835A	BT Screw M3x25 Philips Pan Head	1

9.6. Chassis Ass'y 582 (B04)

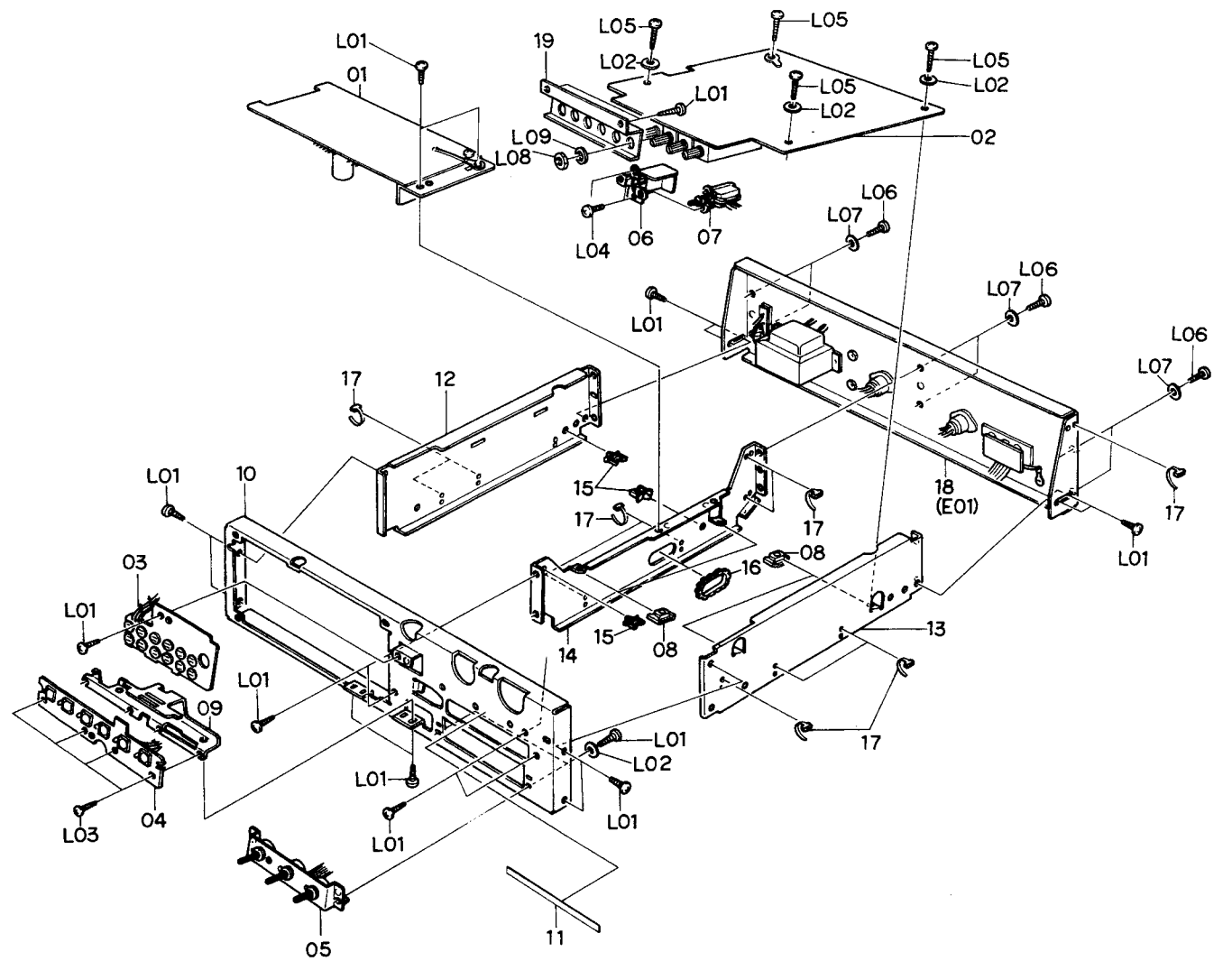

Fig. 9.6

Schematic Ref. No.	Part No.	Description	Q'ty
<b>C01</b>	<b>HA03777A</b>	<b>Lamp House Cover Ass'y</b>	<b>1</b>
01	0J03977B	Lamp House Cover Holder	1
02	BA03974A	Lamp P.C.B. Ass'y	1
03	0H03673A	Lamp House Cover	1
04	0H03674D	Lamp House	3
L01	0E00853A	BT Screw M2x3 Philips Pan Head	2
L02	0E00793A	BT Screw M2x6 Philips Binding Head	2
<b>D01</b>	<b>CA08017B</b>	<b>Flywheel Holder Ass'y</b>	<b>1</b>
01	0C08013I	Flywheel Holder	1
02	0C08135A	Capstan Motor	1
03	0C08079F	Capstan Motor Pulley	1
L01	0E00226A	Screw M2.6x4 Philips Pan Head	3
L02	0E00626A	Screw M2x3 Cup Point	1
L03	0C08068C	Thrust Screw	2
L04	0C03857A	Lock Nut	2
<b>D02</b>	<b>CA08065A</b>	<b>Sub Mechanism Chassis Ass'y</b>	<b>1</b>
01	0C08039A	Reel Hub Head	2
02	CA08038B	Reel Hub B Ass'y	2
03	CA08037A	Reel Hub Take-up Ass'y	1
04	CA08064A	Reel Hub Supply Ass'y	1
05	CA08039A	Back Tension Ass'y	1
06	0C08178A	Back Tension Spring	1
07	CA08040A	Idler Ass'y	1
08	0C08127B	Idler Arm Spring	1
09	CA08042A	Brake Arm Ass'y	2
10	0C08030C	Brake Drive Arm	1
11	0C08129A	Brake Arm Spring	1
12	0C08128A	Brake Drive Arm Spring	1
13	0B04042A	Lug Terminal 1L2P	1
14	0B09091A	Ceramic Capacitor 0.01 $\mu$ 50V	2
15	CA08036A	Reel Motor Ass'y	1
16	CA08034A	Control Motor Ass'y	1
17	0C08053B	Volume Coupler	1
18	0B07240A	Volume Control 10K $\Omega$ (B)	1
19	CA08041A	Sub Chassis Ass'y	1
L01	0E00842A	Stopper Ring 2mm	1
L02	0E00837A	Stopper Ring 3mm	2
L03	0E00838A	Stopper Ring 4mm	1
L04	0E00859A	BT Screw M2.6x6 Philips Binding Head	1
L05	0E00226A	Screw M2.6x4 Philips Pan Head	5
L06	0E00843A	BT Screw M3x5 Philips Pan Head	1
L07	—	Volume Nut	(1)
L08	—	Volume Washer	(1)

Schematic Ref. No.	Part No.	Description	Q'ty	Schematic Ref. No.	Part No.	Description	Q'ty
B04	JA03477B	Chassis Ass'y 582 (U.S.A. & Canada)	1	B04	JA03477A	Chassis Ass'y 582 (U.S.A. & Canada)	1
	JA03478B	Chassis Ass'y 582 (Japan)	1		JA03478A	Chassis Ass'y 582 (Japan)	1
	JA03480B	Chassis Ass'y 582 (Others)	1		JA03480A	Chassis Ass'y 582 (Others)	1
	JA03482B	Chassis Ass'y 582 (UK)	1		JA03482A	Chassis Ass'y 582 (UK)	1
	JA03516B	Chassis Ass'y 582 (220V Class 2)	1		JA03516A	Chassis Ass'y 582 (220V Class 2)	1
	JA03625B	Chassis Ass'y 582 (Australia) Serial No.: A11105952 -	1		JA03625A	Chassis Ass'y 582 (Australia) Serial Nos.: A11101001 - A11105951	1
01	BA04073B	Logic P.C.B. Ass'y (U.S.A., Japan, Canada & Others)	1	01	BA04036A	Logic P.C.B. Ass'y (U.S.A., Japan, Canada & Others)	1
	BA04109B	Logic P.C.B. Ass'y (UK, Australia & 220V Class 2)	1		BA04040A	Logic P.C.B. Ass'y (UK, Australia & 220V Class 2)	1
02	BA04016B	Main P.C.B. Ass'y	1	02	BA04016A	Main P.C.B. Ass'y	1
03	BA04014A	Record Cal. P.C.B. Ass'y	1	03	BA04014A	Record Cal. P.C.B. Ass'y	1
04	BA03976A	Control Switch P.C.B. Ass'y	1	04	BA03976A	Control Switch P.C.B. Ass'y	1
05	BA04013A	Volume P.C.B. Ass'y	1	05	BA04013A	Volume P.C.B. Ass'y	1
06	0J04014A	Power Switch Holder	1	06	0J04014A	Power Switch Holder	1
07	0B07253A	Power Switch (U.S.A., Canada & Others)	1	07	0B07253A	Power Switch (U.S.A., Canada, Japan & Others)	1
	0B07252A	Power Switch (UK, Australia & 220V Class 2)	1		0B07252A	Power Switch (UK, Australia & 220V Class 2)	1
	0B07271A	Power Switch (Japan)	1		0B07271A	Power Switch (Japan)	1
08	0J04013C	P.C.B. Spacer	4	08	0J04013C	P.C.B. Spacer	4
09	0J03976B	Control Switch Holder	1	09	0J03976B	Control Switch Holder	1
10	0J04012B	Front Chassis	1	10	0J04012B	Front Chassis	1
11	0M04052B	Switch Label	1	11	0M04052B	Switch Label	1
12	0J03969C	Side Chassis L	1	12	0J03969C	Side Chassis L	1
13	0J03968D	Side Chassis R	1	13	0J03968D	Side Chassis R	1
14	0J03970D	Center Chassis	1	14	0J03970D	Center Chassis	1
15	0B08580A	Wire Holder 161	3	15	0B08580A	Wire Holder 161	3
16	0B08590A	Free Bushing 80mm	1	16	0B08590A	Free Bushing 80mm	1
17	0B08515A	Insu-Lock	13	17	0B08515A	Insu-Lock	13
18	JA03496A	Rear panel Ass'y (U.S.A. & Canada)	1	18	JA03496A	Rear Panel Ass'y (U.S.A. & Canada)	1
	JA03497A	Rear Panel Ass'y (Japan)	1		JA03497A	Rear Panel Ass'y (Japan)	1
	JA03499A	Rear Panel Ass'y (Others)	1		JA03499A	Rear Panel Ass'y (Others)	1
	JA03501A	Rear Panel Ass'y (UK)	1		JA03501A	Rear Panel Ass'y (UK)	1
	JA03518A	Rear Panel Ass'y (220V Class 2)	1		JA03518A	Rear Panel Ass'y (220V Class 2)	1
	JA03626A	Rear Panel Ass'y (Australia)	1		JA03626A	Rear Panel Ass'y (Australia)	1
19	0J04009C	Switch Holder	1	19	0J04009C	Switch Holder	1
L01	0E00857A	BT Screw M3x6 Philips Binding Head	22	L01	0E00857A	BT Screw M3x6 Philips Binding Head	22
L02	0E00637A	Washer 3.3mm	5	L02	0E00637A	Washer 3.3mm	5
L03	0E00859A	BT Screw M2.6x6 Philips Binding Head	4	L03	0E00859A	BT Screw M2.6x6 Philips Binding Head	4
L04	0E00502A	Screw M3x5 Philips Pan Head	2	L04	0E00502A	Screw M3x5 Philips Pan Head	2
L05	0E00865A	BT Screw M3x10 Philips Binding Head	4	L05	0E00865A	BT Screw M3x10 Philips Binding Head	4
L06	0E00860A	BT Screw M3x6 Philips Binding Head (Black)	6	L06	0E00860A	BT Screw M3x6 Philips Binding Head (Black)	6
L07	0E00157A	Washer 3mm (Black Plastics)	6	L07	0E00157A	Washer 3mm (Black Plastics)	6



9.7. Lamp House Cover Ass'y (C01)

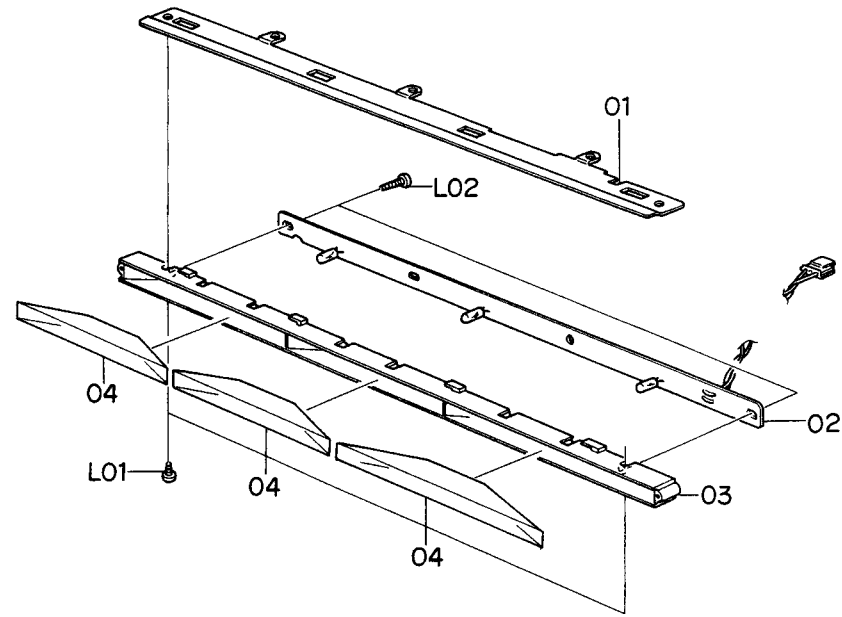

Fig. 9.7

9.8. Flywheel Holder Ass'y (D01)

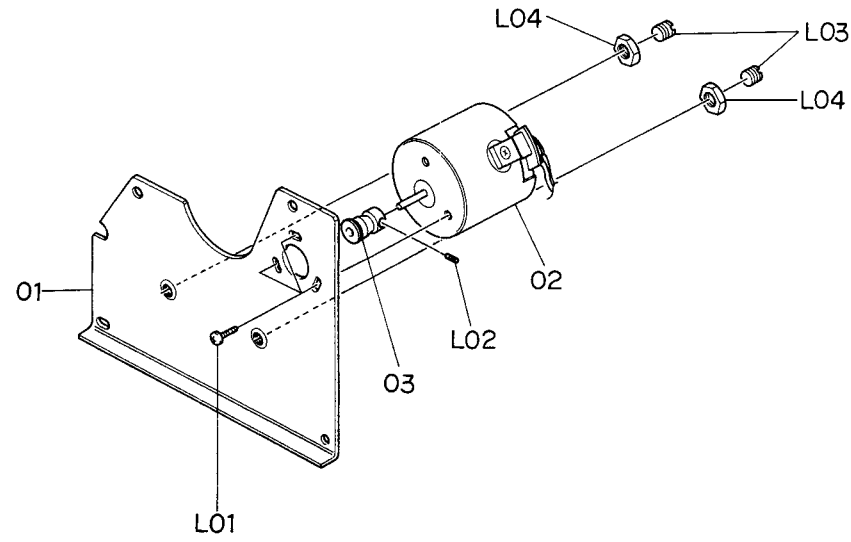

Fig. 9.8

9.9. Sub Mechanism Chassis Ass'y (D02)

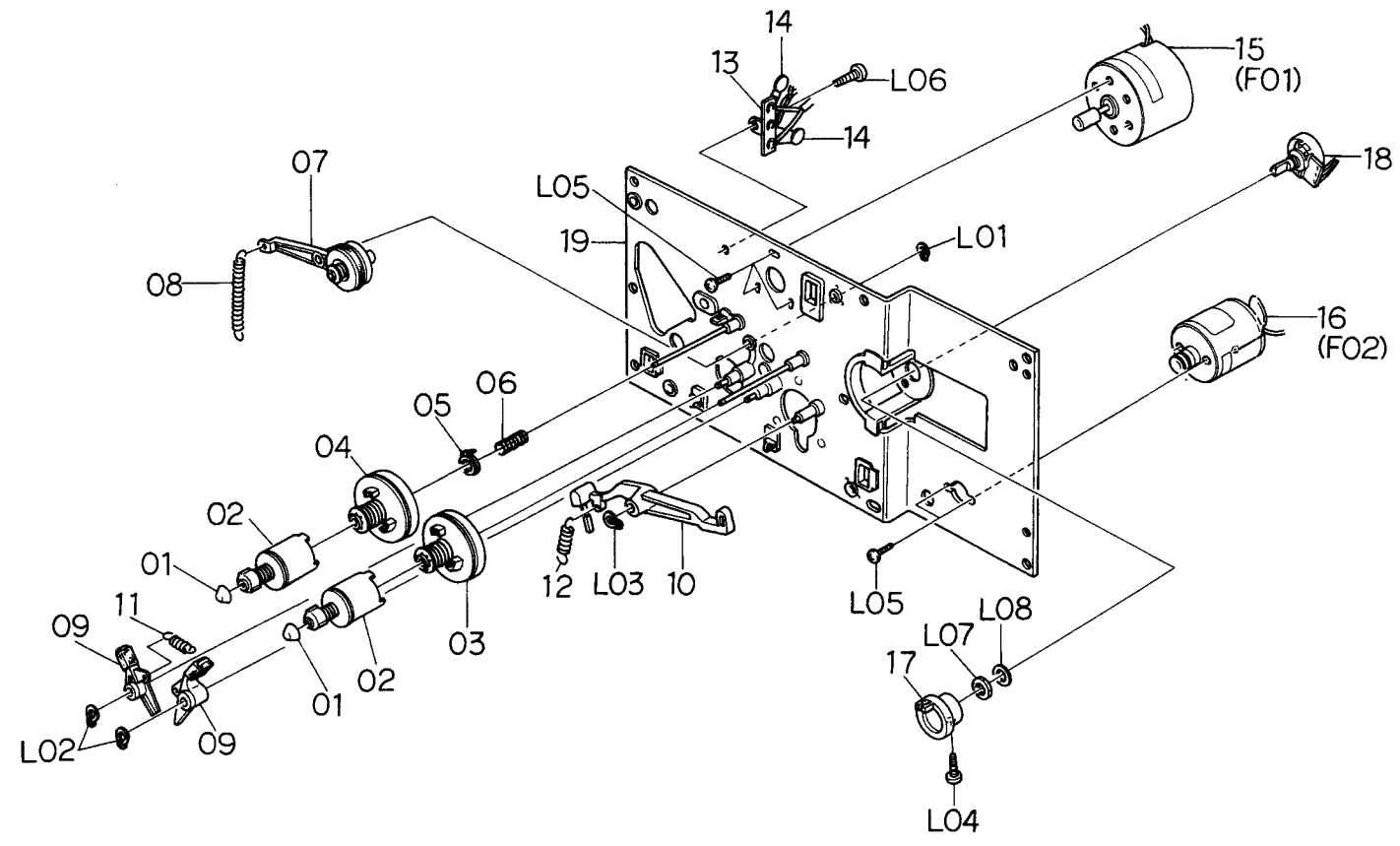

Fig. 9.9

9.10. Main Mechanism Chassis Ass'y (D03)

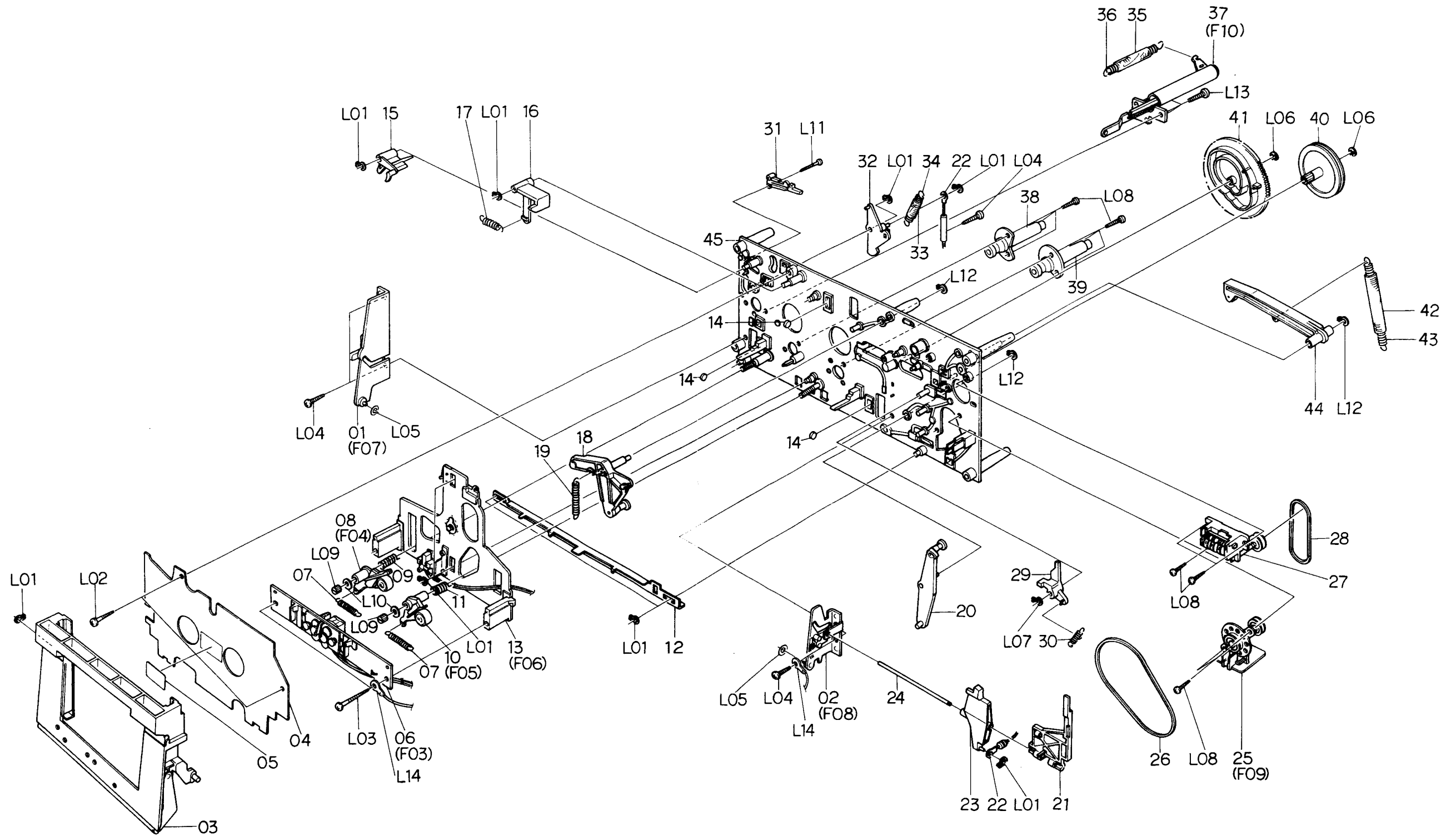

Fig. 9.10

Schematic Ref. No.	Part No.	Description	Q'ty	Schematic Ref. No.	Part No.	Description	Q'ty	Schematic Ref. No.	Part No.	Description	Q'ty
D03	CA08078B	Main Mechanism Chassis Ass'y Serial No.: A11106110 -	1	L11	0E00879A	BT Screw M2x15 Philips Pan Head	1	L04	0E00831A	BT Screw M3x10 Philips Pan Head	4
01	CA08048A	Cassette Case Holder L Ass'y	1	L12	0E00838A	Stopper Ring 4mm	3	L05	0E00254A	Washer 3.1mm (Plastics)	2
02	CA08022A	Cassette Case Holder R Ass'y	1	L13	0E00846A	BT Screw M3x8 Philips Pan Head	3	L06	0E00222A	E-Ring 2mm	2
03	CA08055A	Cassette Case Ass'y	1	L14	0E00895A	Earth Lug 3mm	2	L07	0E00839A	Stopper Ring 2.5mm	1
04	0C08019I	Cover Plate	1					L08	0E00876A	BT Screw M2.6x8 Philips Pan Head	11
05	0M03977A	Cassette Viewer Label	1	D03	CA08078A	Main Mechanism Chassis Ass'y Serial Nos.: A11101001 - A11106109	1	L09	0C08060B	Height Adjustment Nut	2
06	CA08056C	Head Mount Base Ass'y	1	01	CA08048A	Cassette Case Holder L Ass'y	1	L10	0E00142A	Washer 2.6mm	2
07	0C08121A	Supply Pressure Roller Spring	2	02	CA08022A	Cassette Case Holder R Ass'y	1	L11	0E00879A	BT Screw M2x15 Philips Pan Head	1
08	CA08053B	Supply Pressure Roller Ass'y	1	03	CA08055A	Cassette Case Ass'y	1	L12	0E00838A	Stopper Ring 4mm	3
09	0C08122B	Supply Pressure Roller Thrust Spring	1	04	0C08019I	Cover Plate	1	L13	0E00846A	BT Screw M3x8 Philips Pan Head	3
10	CA08079A	Take-up Pressure Roller Ass'y	1	05	0M03977A	Cassette Viewer Label	1	L14	0E00895A	Earth Lug 3mm	2
11	0C08183B	Take-up Pressure Roller Thrust Spring	1	06	CA08056C	Head Mount Base Ass'y	1				
12	0C08182A	Pressure Roller Drive Bar B	1	07	0C08121A	Supply Pressure Roller Spring	2				
13	CA08129A	Head Base Ass'y B	1	08	CA08053B	Supply Pressure Roller Ass'y	1				
14	0C08086B	Head Base Roller	3	09	0C08122B	Supply Pressure Roller Thrust Spring	1				
15	0C08050B	Record Sensor	1	10	CA08079A	Take-up Pressure Roller Ass'y	1				
16	0C08051E	Cassette Hold Arm	1	11	0C08183B	Take-up Pressure Roller Thrust Spring	1				
17	0C08120A	Cassette Hold Arm Spring	1	12	0C08182A	Pressure Roller Drive Bar B	1				
18	CA08027A	Head Base Drive Arm Ass'y	1	13	CA08129A	Head Base Ass'y B	1				
19	0C08143C	Head Base Drive Arm Spring	1	14	0C08086B	Head Base Roller	3				
20	CA08026A	Pressure Roller Drive Arm Ass'y	1	15	0C08050B	Record Sensor	1				
21	0C08071C	Counter Reset Arm	1	16	0C08051E	Cassette Hold Arm	1				
22	0C08124B	Eject Linkage Wire	1	17	0C08120A	Cassette Hold Arm Spring	1				
23	0C08057E	Eject Arm	1	18	CA08027A	Head Base Drive Arm Ass'y	1				
24	0C08078B	Arm Shaft	1	19	0C08143C	Head Base Drive Arm Spring	1				
25	CA08032B	Auto Shut-off Ass'y	1	20	CA08026A	Pressure Roller Drive Arm Ass'y	1				
26	0C08097B	Counter Belt A	1	21	0C08071C	Counter Reset Arm	1				
27	CA08020A	Counter Ass'y	1	22	0C08124B	Eject Linkage Wire	1				
28	0C08098B	Counter Belt B	1	23	0C08057E	Eject Arm	1				
29	0C08067C	Eject Stopper	1	24	0C08078B	Arm Shaft	1				
30	0C08134C	Eject Stopper Spring	1	25	CA08032A	Auto Shut-off Ass'y	1				
31	0C08119A	Record Protector	1	26	0C08097B	Counter Belt A	1				
32	0C08052H	Damper Lock Arm	1	27	CA08020A	Counter Ass'y	1				
33	0C08153A	Damper Arm Spring Tube	1	28	0C08098B	Counter Belt B	1				
34	0C08125A	Damper Arm Spring	1	29	0C08067C	Eject Stopper	1				
35	0C08151A	Lid Arm Spring Tube	1	30	0C08134C	Eject Stopper Spring	1				
36	0C08114A	Lid Arm Spring	1	31	0C08119A	Record Protector	1				
37	CA08030A	Pneumatic Damper Ass'y	1	32	0C08052H	Damper Lock Arm	1				
38	CA08023A	Supply Capstan Flange Ass'y	1	33	0C08153A	Damper Arm Spring Tube	1				
39	CA08024A	Take-up Capstan Flange Ass'y	1	34	0C08125A	Damper Arm Spring	1				
40	0C08065D	Cam Drive Gear	1	35	0C08151A	Lid Arm Spring Tube	1				
41	0C08029H	Control Cam	1	36	0C08114A	Lid Arm Spring	1				
42	0C08117A	Counter-Load Arm Spring	1	37	CA08030A	Pneumatic Damper Ass'y	1				
43	0C08152A	Counter-Load Arm Spring Tube	1	38	CA08023A	Supply Capstan Flange Ass'y	1				
44	CA08028A	Counter-Load Arm Ass'y	1	39	CA08024A	Take-up Capstan Flange Ass'y	1				
45	CA08072A	Main Chassis Ass'y	1	40	0C08065D	Cam Drive Gear	1				
L01	0E00837A	Stopper Ring 3mm	11	41	0C08029H	Control Cam	1				
L02	0E00832A	BT Screw M3x14 Philips Pan Head	2	42	0C08117A	Counter-Load Arm Spring	1				
L03	0E00834A	BT Screw M3x30 Philips Pan Head	2	43	0C08152A	Counter-Load Arm Spring Tube	1				
L04	0E00831A	BT Screw M3x10 Philips Pan Head	4	44	CA08028A	Counter-Load Arm Ass'y	1				
L05	0E00254A	Washer 3.1mm (Plastics)	2	45	CA08072A	Main Chassis Ass'y	1				
L06	0E00222A	E-Ring 2mm	2	L01	0E00837A	Stopper Ring 3mm	11				
L07	0E00839A	Stopper Ring 2.5mm	1	L02	0E00832A	BT Screw M3x14 Philips Pan Head	2				
L08	0E00876A	BT Screw M2.6x8 Philips Pan Head	11	L03	0E00834A	BT Screw M3x30 Philips Pan Head	2				
L09	0C08060B	Height Adjustment Nut	2								
L10	0E00142A	Washer 2.6mm	2								

9.11. Rear Panel Ass'y (E01)

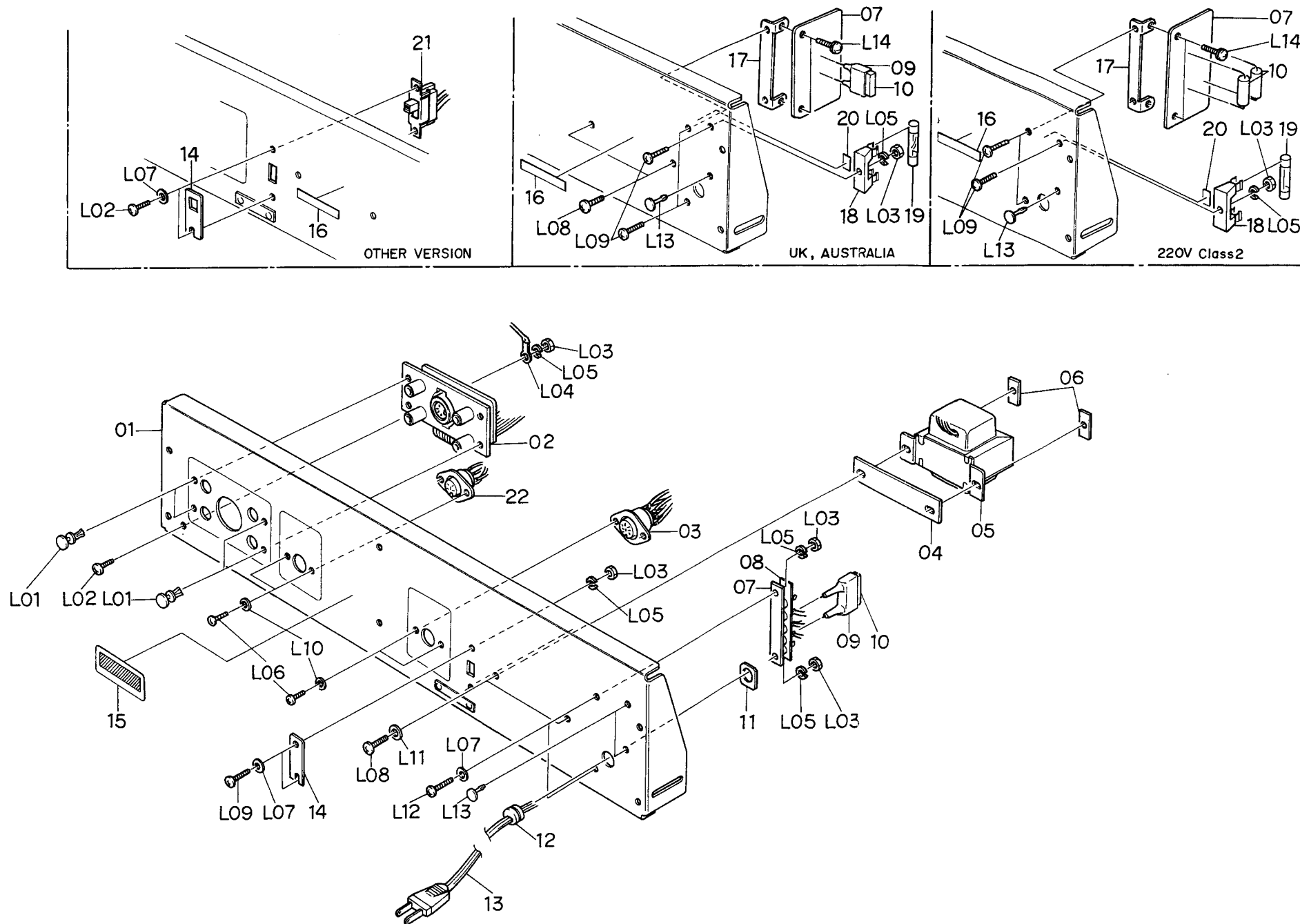

Fig. 9.11

Schematic Ref. No.	Part No.	Description	Q'ty
E01	JA03496A	Rear Panel Ass'y (U.S.A. & Canada)	1
	JA03497A	Rear Panel Ass'y (Japan)	1
	JA03499A	Rear Panel Ass'y (Others)	1
	JA03501A	Rear Panel Ass'y (UK)	1
	JA03518A	Rear Panel Ass'y (220V Class 2)	1
	JA03626A	Rear Panel Ass'y (Australia)	1
01	0J04011D	Rear Panel	1
02	BA04031A	DIN-Pin P.C.B. Ass'y	1
03	0B08584A	8P DIN Socket	1
04	0J04016A	Transformer Plate	1
05	0B06609A	Power Transformer (U.S.A. & Canada)	1
	0B06610A	Power Transformer (Japan)	1
	0B06611A	Power Transformer (Others)	1
	0B06612A	Power Transformer (UK, Australia & 220V Class 2)	1
	06	0C01162B	Bolt Receptacle Plate
07	0B08025U	5P Terminal Strip (U.S.A., Canada, Japan & Others)	1
	0B07817A	Terminal P.C.B. C (UK, Australia & 220V Class 2)	1
08	0B08555A	5P Terminal Insulator 08 (U.S.A., Canada, Japan & Others)	1
09	0B08359A	Spark Killer Cover (U.S.A., Canada, Japan & Others)	1
10	0B08342A	Spark Killer (U.S.A. & Canada)	1
	0B08363A	Spark Killer (Japan)	1
	0B08240U	Spark Killer (UK, Australia & Others)	1
	0B08445A	Spark Killer (220V Class 2)	1
11	0A03154B	Cord Spacer	1
12	0B08037U	Cord Bushing C (U.S.A., Canada, Japan, 220V Class 2 & Others)	1
	0B08351A	Cord Bushing 4K-4 (UK)	1
13	0B08325U	Cord Bushing E (Australia)	1
	0B08533A	Power Cord (U.S.A., Canada & Others)	1
14	0B08219B	Power Cord (Japan)	1
	0B08348A	Power Cord (UK)	1
	0B08093A	Power Cord (220V Class 2)	1
	0B08666A	Power Cord (Australia)	1
15	0J03663A	Switch Cover (U.S.A., Canada, Japan, UK, Australia & 220V Class 2)	1
	0M03946A	Voltage Selector Lock Plate C (Others)	1
16	0M03458A	Pass Label	1
	0M03794A	Voltage Label 100V (Japan)	1
17	0M03796A	Voltage Label 220V (220V Class 2)	1
	0M03797A	Voltage Label 240V (UK & Australia)	1
	0M03955A	Voltage Label 120V/220-240V (Others)	1
18	0J03893A	Terminal P.C.B. Holder B (UK, Australia & 220V Class 2)	1
19	0B08048A	Fuse Holder (UK, Australia & 220V Class 2)	1
20	0B08344A	Fuse 200mA T, 250V (UK, Australia & 220V Class 2)	1
	0M03968A	Fuse Label 200mA T (UK, Australia & 220V Class 2)	1

9.15. Supply Pressure Roller Ass'y (F04)

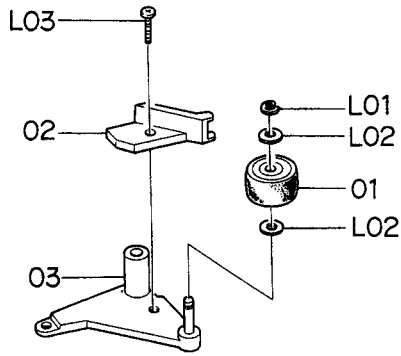

Fig. 9.15

9.16. Take-up Pressure Roller Ass'y (F05)

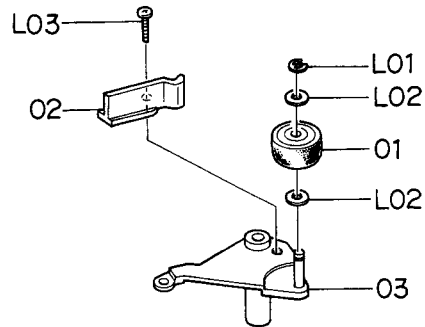

Fig. 9.16

9.17. Head Base Ass'y A (F06)

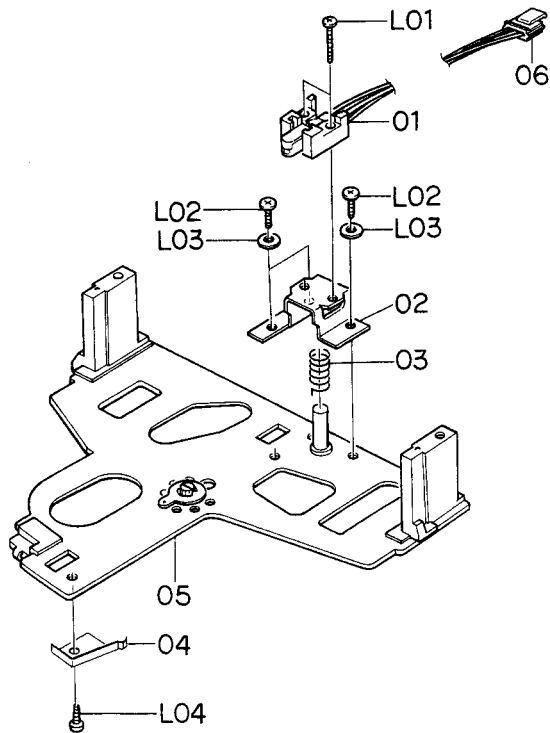

Fig. 9.17

9.18. Cassette Case Holder L Ass'y (F07)

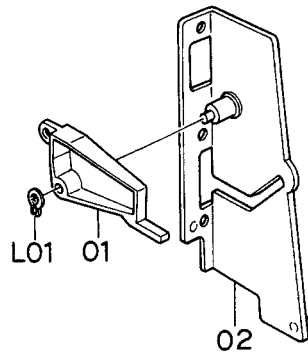

Fig. 9.18

9.19. Cassette Case Holder R Ass'y (F08)

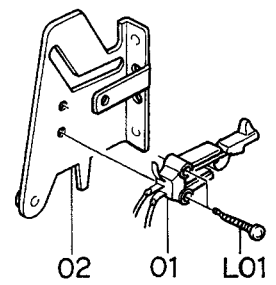

Fig. 9.19

9.20. Auto Shut-off Ass'y (F09)

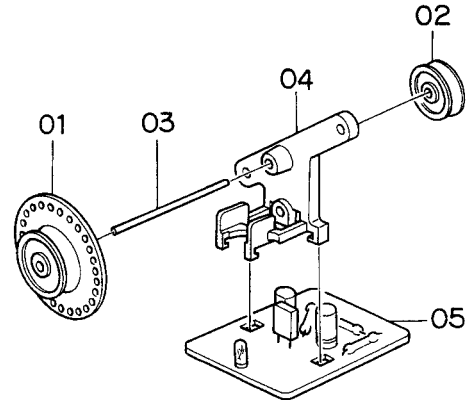

Fig. 9.20.1  
Serial No.: A11106110 -

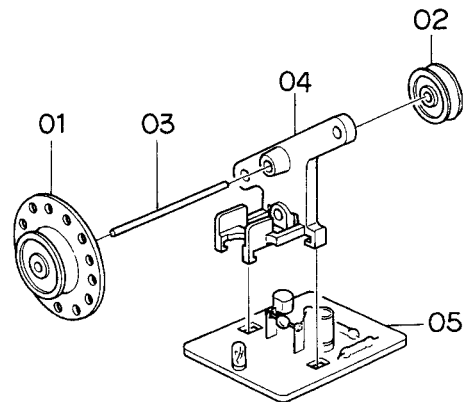

Fig. 9.20.2  
Serial Nos.: A11101001 - A11106109

Schematic Ref. No.	Part No.	Description	Q'ty
21	0B07092U	Voltage Selector (Others)	1
22	0B08355A	4P DIN Socket	1
-	0M03844B	Power Cord Label (UK & Australia)	1
-	0F01071A	Free-up Belt	1
-	0M03996A	Serial Number Plate	1
-	0M03798A	Nakamichi Label (Japan)	1
-	0M04055A	SDNF Label (220V Class 2)	1
-	0M03865A	SEV Label (220V Class 2)	1
-	0M03697A	Rating Label (220V Class 2)	1
L01	0B08539A	Plastic Rivet	4
L02	0E00593A	Screw M3x6 Philips Binding Head (Bronze)	3
L03	0E00507A	Nut 3mm	6
L04	0E00037A	Earth Lug B-5	1
L05	0E00581A	Washer 3mm Spring	6
L06	0E00714A	Screw M2.6x6 Philips Binding Head (Bronze)	4
L07	0E00157A	Washer 3mm (Black Plastics)	4
L08	0E00756A	Screw M4x8 Philips Binding Head (Bronze)	2
L09	0E00594A	Screw M3x8 Philips Binding Head (Bronze)	5
L10	0E00651A	Washer 2.6mm (Black Plastics)	4
L11	0E00645A	Washer 4mm (Black Plastics)	2
L12	0E00701A	Screw M3x10 Philips Binding Head (Bronze)	2
L13	0B08583A	Plastic Clip	2
L14	0E00510A	Screw M3x8 Philips Pan Head (2A)	2
-	0J03644A	Chobert Rivet	2
<b>F01</b>	<b>CA08036A</b>	<b>Reel Motor Ass'y</b>	<b>1</b>
01	0C08138A	Reel Motor	1
02	0C08063E	Reel Motor Pulley	1
03	0M03902A	Motor Level 730	1
04	0M03987A	Motor Seal A	1
L01	0E00672A	Screw M2x2 Cup Point	1
<b>F02</b>	<b>CA08034A</b>	<b>Control Motor Ass'y</b>	<b>1</b>
01	0C08137A	Control Motor	1
02	0C08064A	Control Motor Pulley	1
03	0B01356A	Ceramic Capacitor 0.1 $\mu$ 50V	1
04	0M03985A	Control Motor Label	1
05	0M03988A	Motor Seal B	1
<b>F03</b>	<b>CA08056C</b>	<b>Head Mount Base Ass'y</b>	<b>1</b>
01	0C08028C	Head Height Adjustment Gear	2
02	0C08027E	Head Height Adjustment Screw	4
03	0C08026D	Azimuth Alignment Screw	2
04	0C08161B	Spring Stopper	2
05	0C08187B	Head Plate Spring	2
06	CA08083C	Head Mount Base Sub Ass'y	1
07	CA08127A	P-8L Playback Head Ass'y	1
08	CA08128A	R-8L Record Head Ass'y	1

## 9.12. Reel Motor Ass'y (F01)

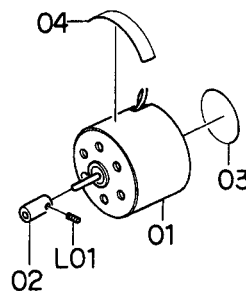

Fig. 9.12

## 9.13. Control Motor Ass'y (F02)

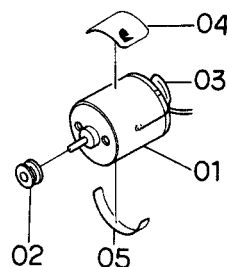

Fig. 9.13

## 9.14. Head Mount Base Ass'y (F03)

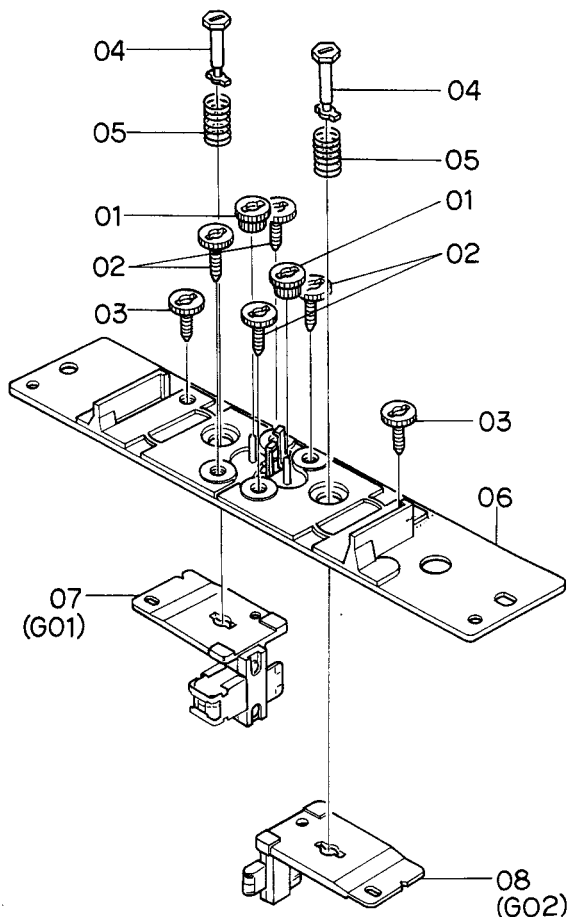

Fig. 9.14

9.21. Pneumatic Damper Ass'y (F10)

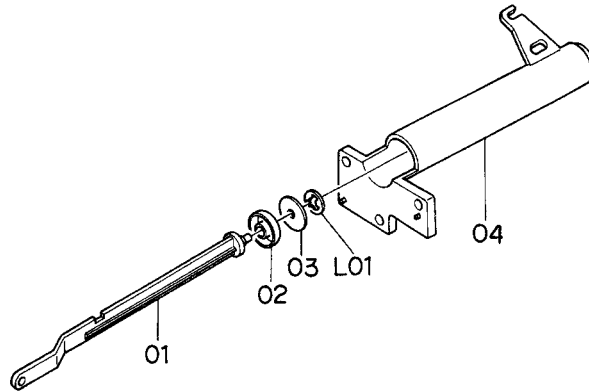

Fig. 9.21

Schematic Ref. No.	Part No.	Description	Q'ty	Schematic Ref. No.	Part No.	Description	Q'ty
<b>F04</b>	<b>CA08053B</b>	<b>Supply Pressure Roller Ass'y</b>	<b>1</b>	<b>F08</b>	<b>CA08022A</b>	<b>Cassette Case Holder R Ass'y</b>	<b>1</b>
01	0C08164E	Pressure Roller	1	01	0C08133A	Eject Sensor	1
02	0C08189B	Supply Tape Guide	1	02	CA08044A	Cassette Case Holder R Sub Ass'y	1
03	CA08061A	Supply Pressure Roller Arm Ass'y	1	L01	0E00840A	BT Screw M2x8 Philips Pan Head	2
L01	0E00042A	E-Ring 1.5mm	1				
L02	0C08024A	Washer 2mm	2	<b>F09</b>	<b>CA08032B</b>	<b>Auto Shut-off Ass'y</b>	<b>1</b>
L03	0E00788A	BT Screw M2x8 Philips Pan Head	1			Serial No.: A11106110 –	
<b>F05</b>	<b>CA08079A</b>	<b>Take-up Pressure Roller Ass'y</b>	<b>1</b>	01	0C08206B	Shut-off Pulley B	1
01	0C08164E	Pressure Roller	1	02	0C08047A	Shut-off Pulley A	1
02	0C08181B	Take-up Tape Guide	1	03	0C08088B	Shut-off Pulley Shaft	1
03	CA08073B	Take-up Pressure Roller Arm Ass'y	1	04	0C08207B	Shut-off Pulley Holder	1
L01	0E00042A	E-Ring 1.5mm	1	05	BA04076A	Shut-off P.C.B. Ass'y	1
L02	0C08024A	Washer 2mm	2				
L03	0E00788A	BT Screw M2x8 Philips Pan Head	1	<b>F09</b>	<b>CA08032A</b>	<b>Auto Shut-off Ass'y</b>	<b>1</b>
<b>F06</b>	<b>CA08129A</b>	<b>Head Base Ass'y B</b>	<b>1</b>			Serial Nos.: A11101001 – A11106109	
01	GA02017A	Erase Head E-8L	1	01	0C08048A	Shut-off Pulley B	1
02	0C08158C	EH Hold Plate	1	02	0C08047A	Shut-off Pulley A	1
03	0C08166A	EH Hold Plate Spring	1	03	0C08088B	Shut-off Pulley Shaft	1
04	0C08174C	Cassette Hold Spring	1	04	0C08046A	Shut-off Pulley Holder	1
05	CA08003O	Head Base Ass'y	1	05	BA03975A	Shut-off P.C.B. Ass'y	1
06	0B08620C	3P-H Connector	1	<b>F10</b>	<b>CA08030A</b>	<b>Pneumatic Damper Ass'y</b>	<b>1</b>
L01	0E00889A	Screw M1.7x8 Philips Pan Head	2	01	0C08058C	Damper Piston	1
L02	0E00185A	Screw M2x6 Cylinder Head	3	02	0C08102B	Damper Ring	1
L03	0E00117A	Washer 2mm	3	03	0C08010C	Damper Plate	1
L04	0E00794A	BT Screw M2x5 Philips Pan Head	1	04	0C08059E	Sylinder	1
<b>F07</b>	<b>CA08048A</b>	<b>Cassette Case Holder L Ass'y</b>	<b>1</b>	L01	0E00874A	Stopper Ring CS 2mm	1
01	0C08073C	Lid Arm A	1				
02	CA08035A	Cassette Case Holder L Sub Ass'y	1				
L01	0E00837A	Stopper Ring 3mm	1				

9.22. P-8L Playback Head Ass'y (G01)

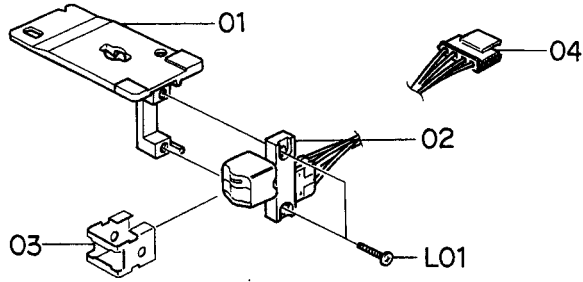

Fig. 9.22

9.23. R-8L Record Head Ass'y (G02)

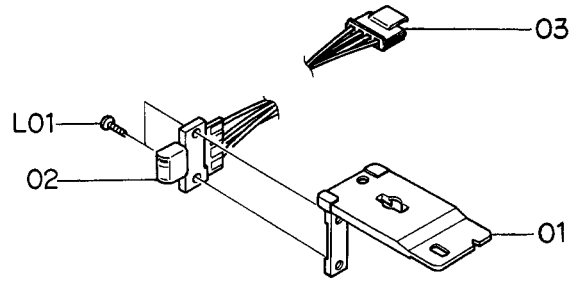

Fig. 9.23

Schematic Ref. No.	Part No.	Description	Q'ty	Schematic Ref. No.	Part No.	Description	Q'ty
G01	CA08127A	P-8L Playback Head Ass'y	1	G02	CA08128A	R-8L Record Head Ass'y	1
01	0C08160F	Head Plate	1	01	0C08159G	Head Plate	1
02	GA02034A	P-8L Playback Head	1	02	GA01050A	R-8L Record Head	1
03	0C08169D	Pad Lifter 54	1	03	0B08619C	4P-H Connector B	1
04	0B08618C	4P-H Connector A	1	L01	0E00887A	Screw M1.7x4 Philips Pan Head	2
L01	0E00886A	Screw M1.7x6.5 Philips Pan Head	2				

10. OVERALL TIMING CHART

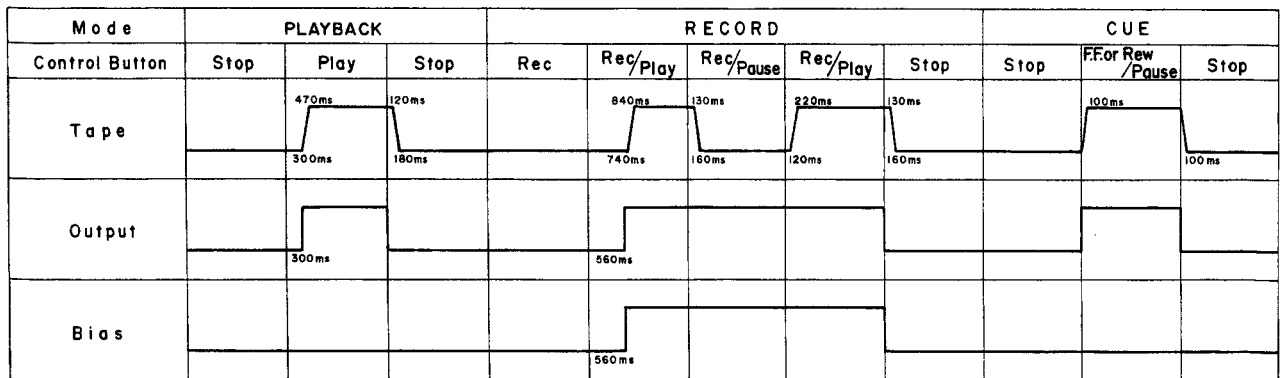

Fig. 10



12. WIRING DIAGRAM

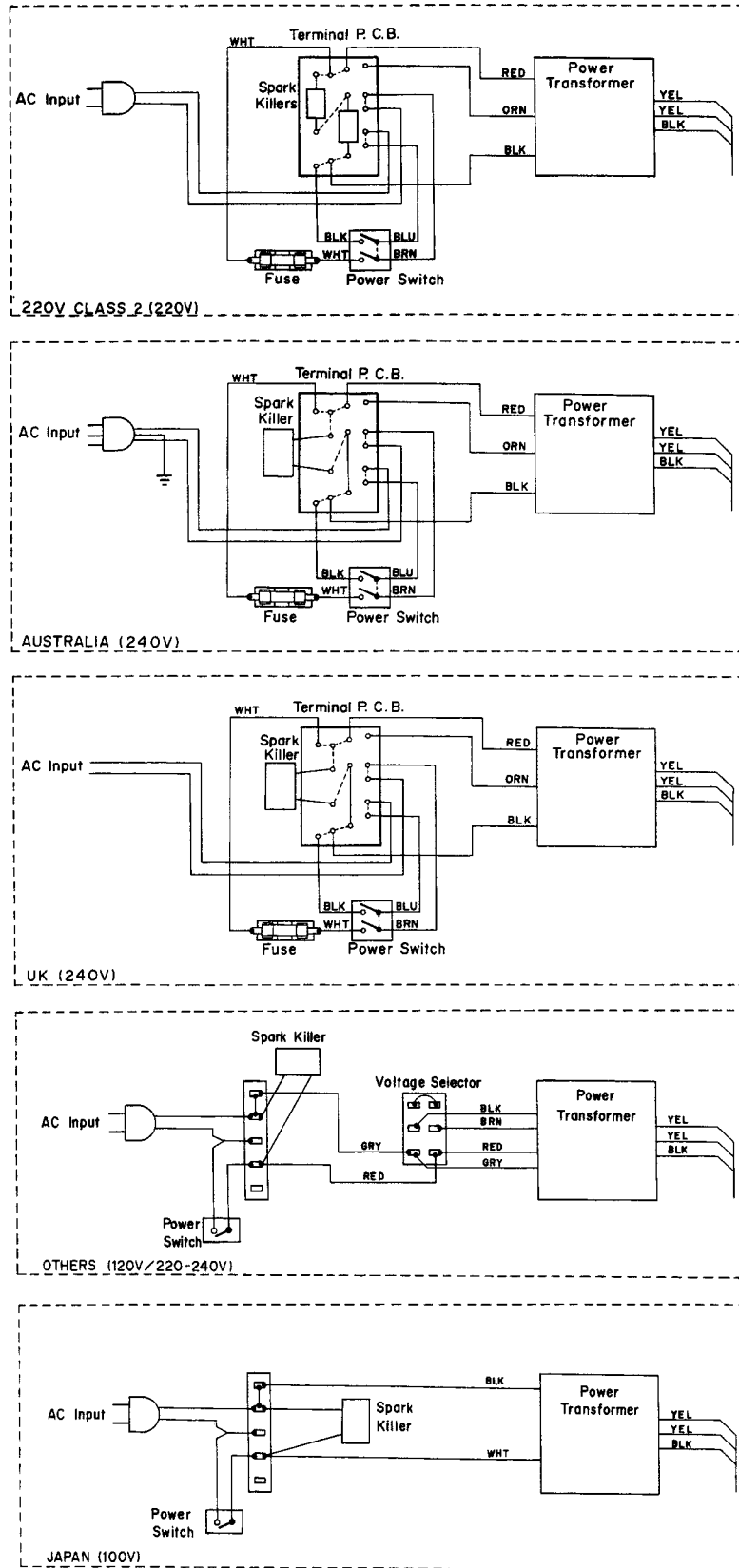

Fig. 12.1

11. EQ. AMP. FREQUENCY RESPONSE

11.1. Playback Frequency Response

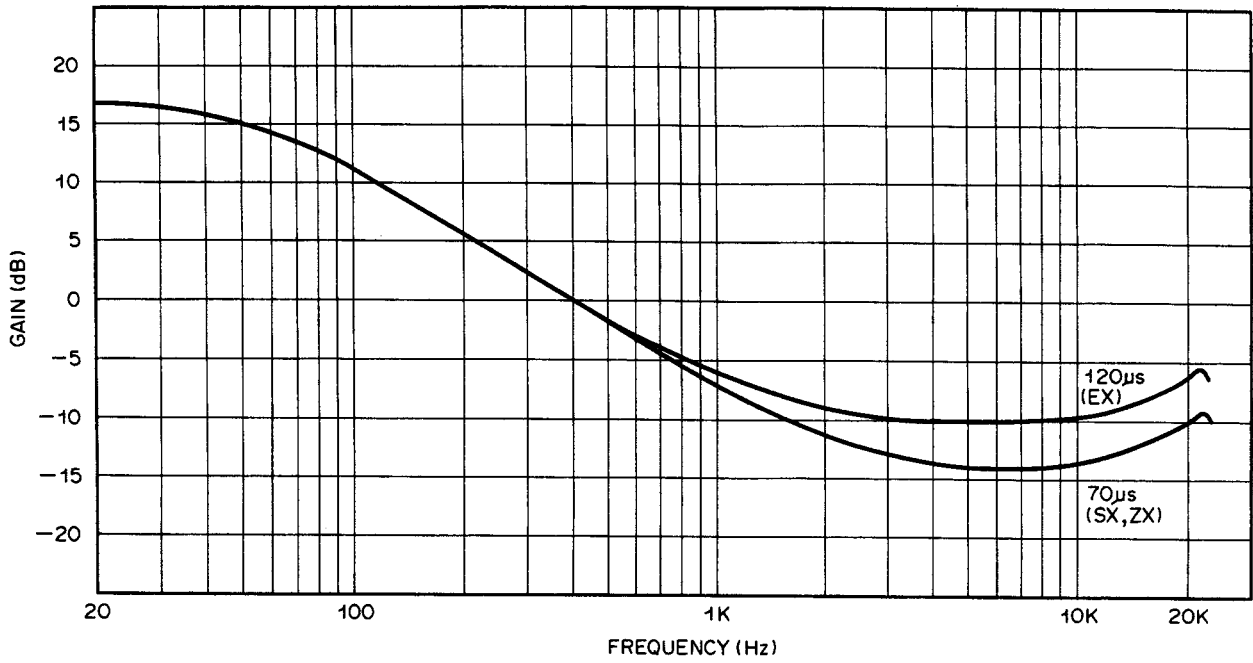

Fig. 11.1

11.2. Record Current Frequency Response

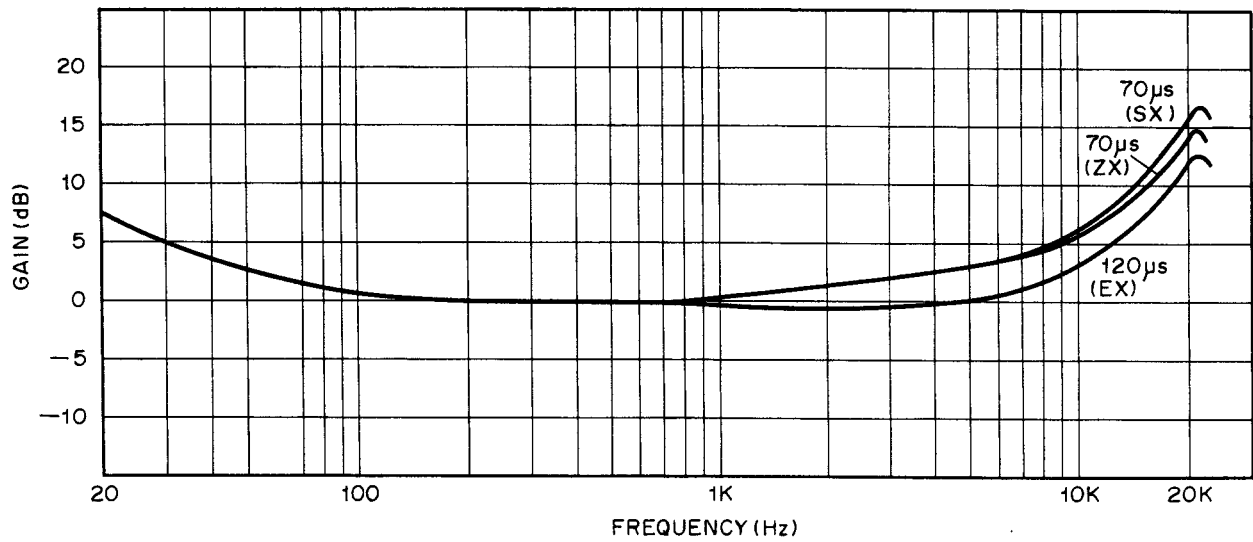
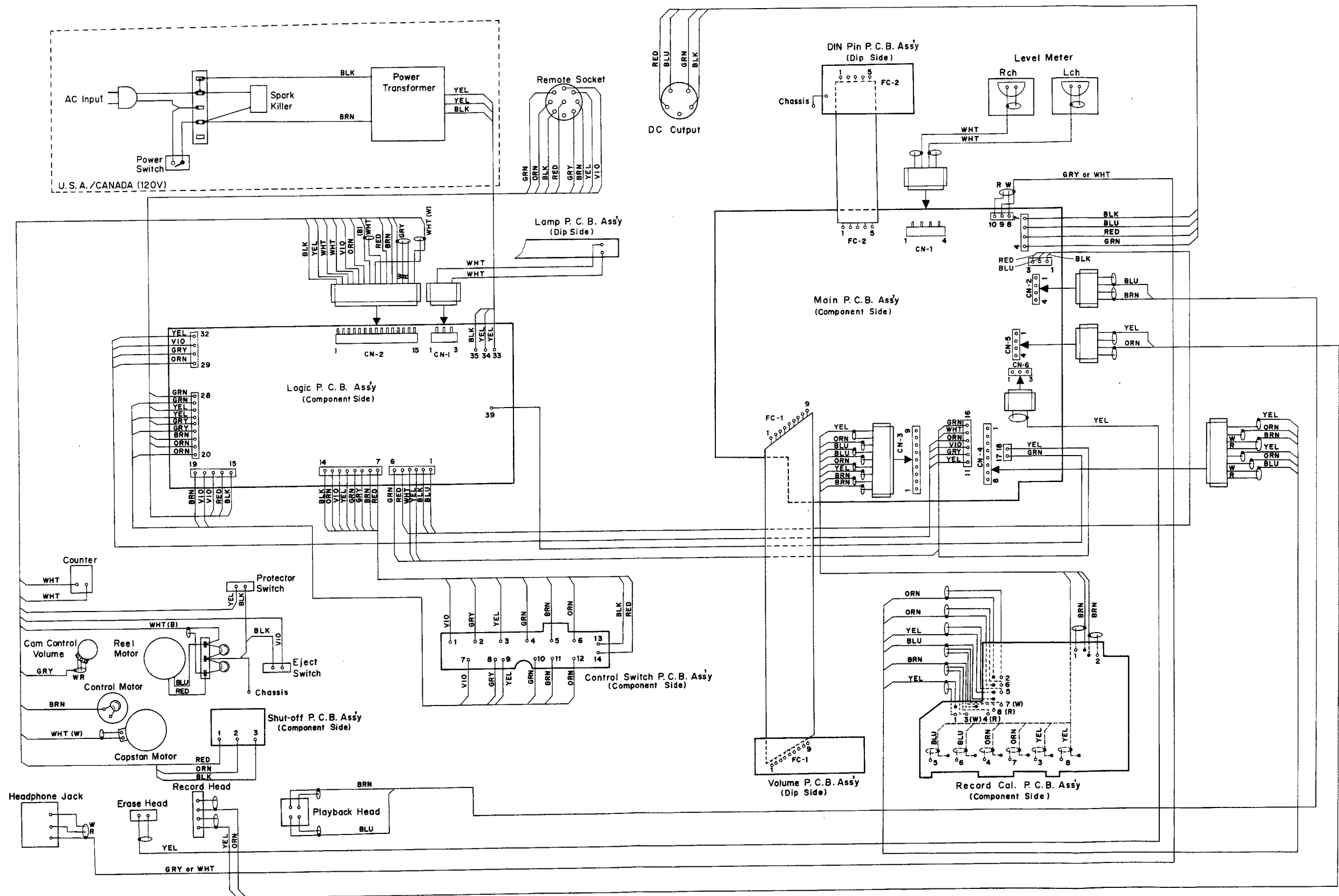

Fig. 11.2



Note: Table of wire colors

BLK – Black	GRY – Gray	BRN – Brown
BLU – Blue	GRN – Green	YEL – Yellow
ORN – Orange	RED – Red	WHT – White

Fig. 12.2

13. BLOCK DIAGRAMS

13.1. Amplifier

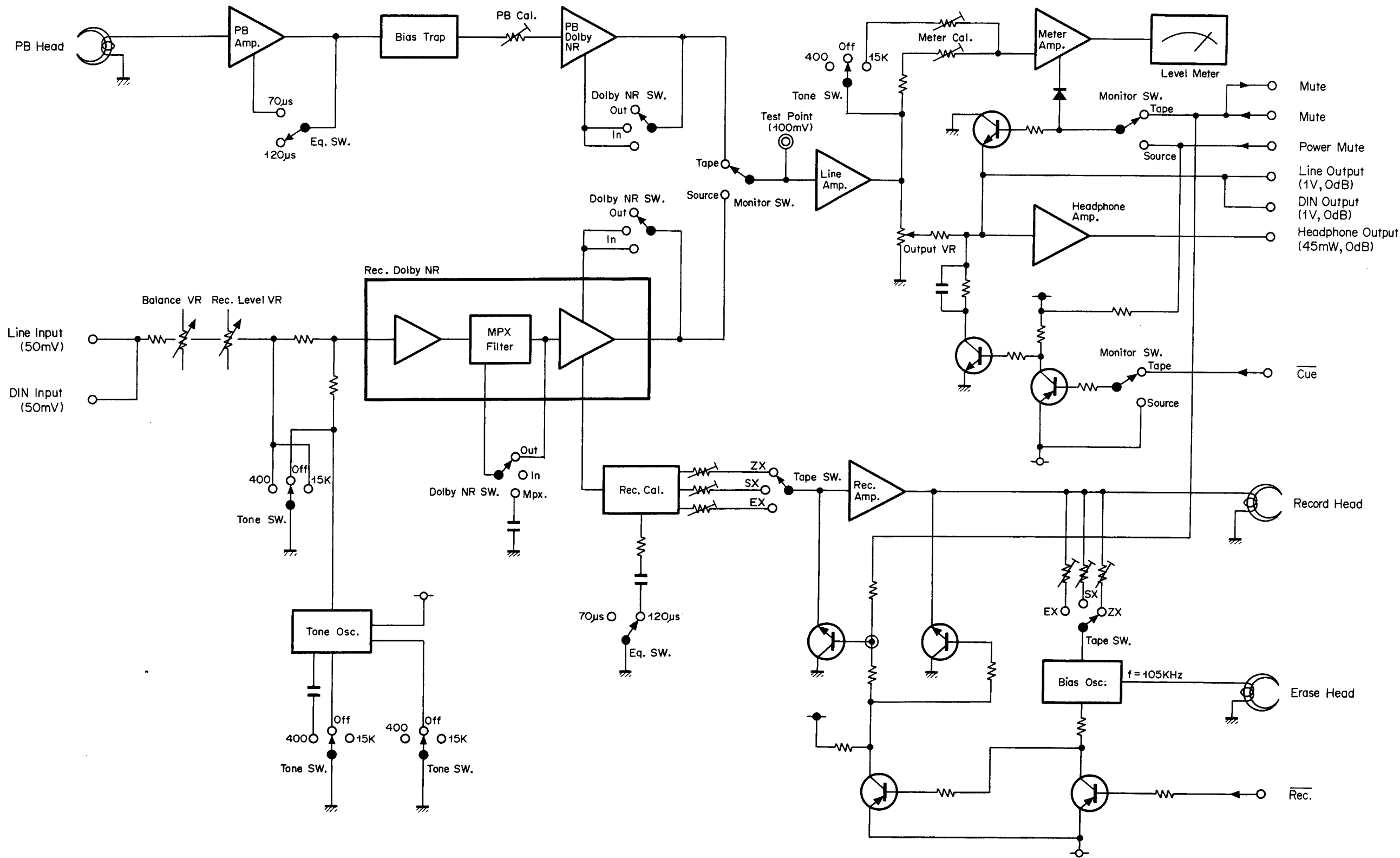

Fig. 13.1

13.2. Mechanism Control

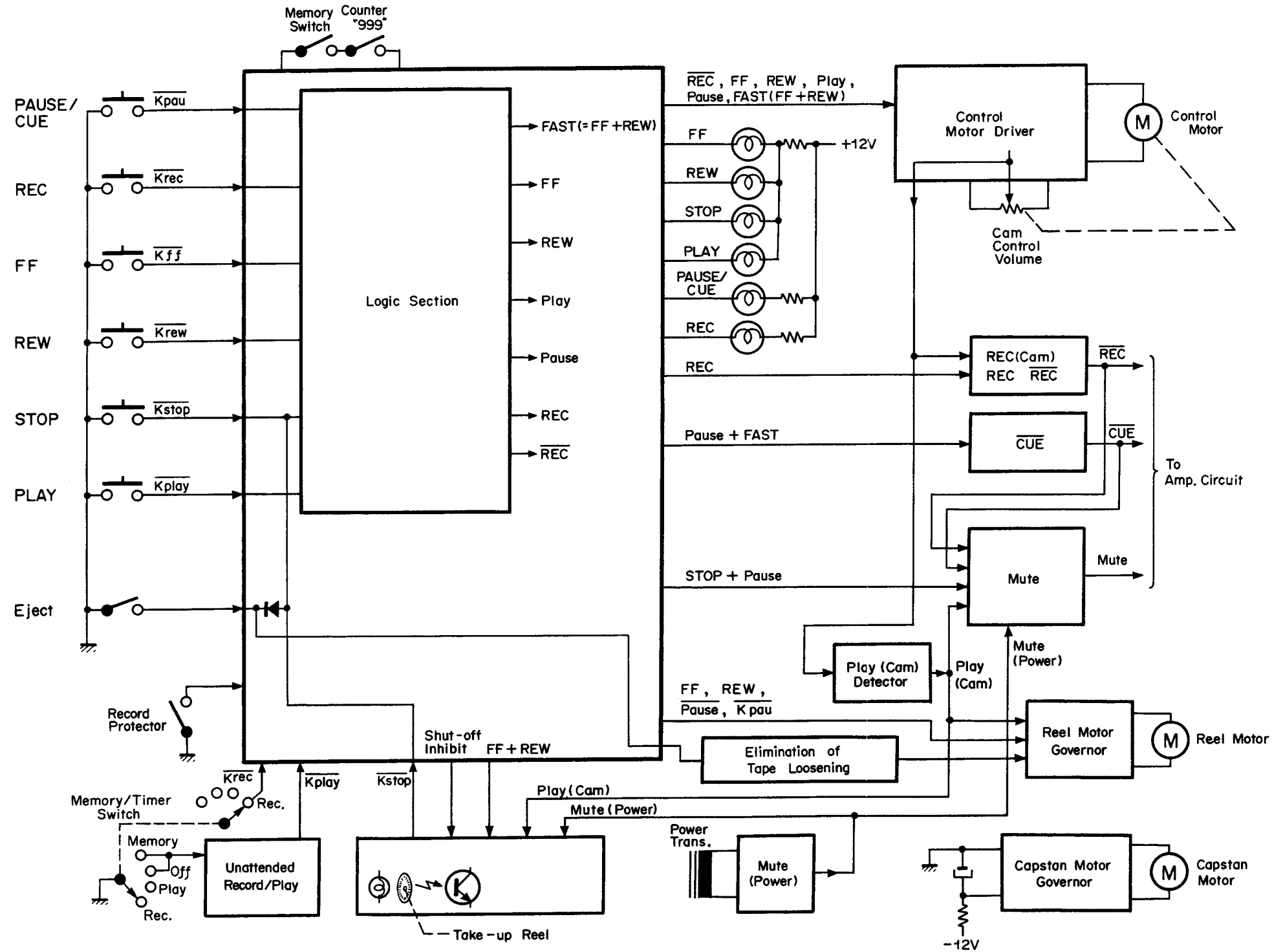

Fig. 13.2

### 14. SCHEMATIC DIAGRAMS

Note: Refer to diagrams of ICs on page 81.

#### 14.1. Amplifier

Notes: 1. Diode is 1S553, 1S953, or 1S1555 unless otherwise specified.  
2. Resistor and capacitor marked with \* show typical value.

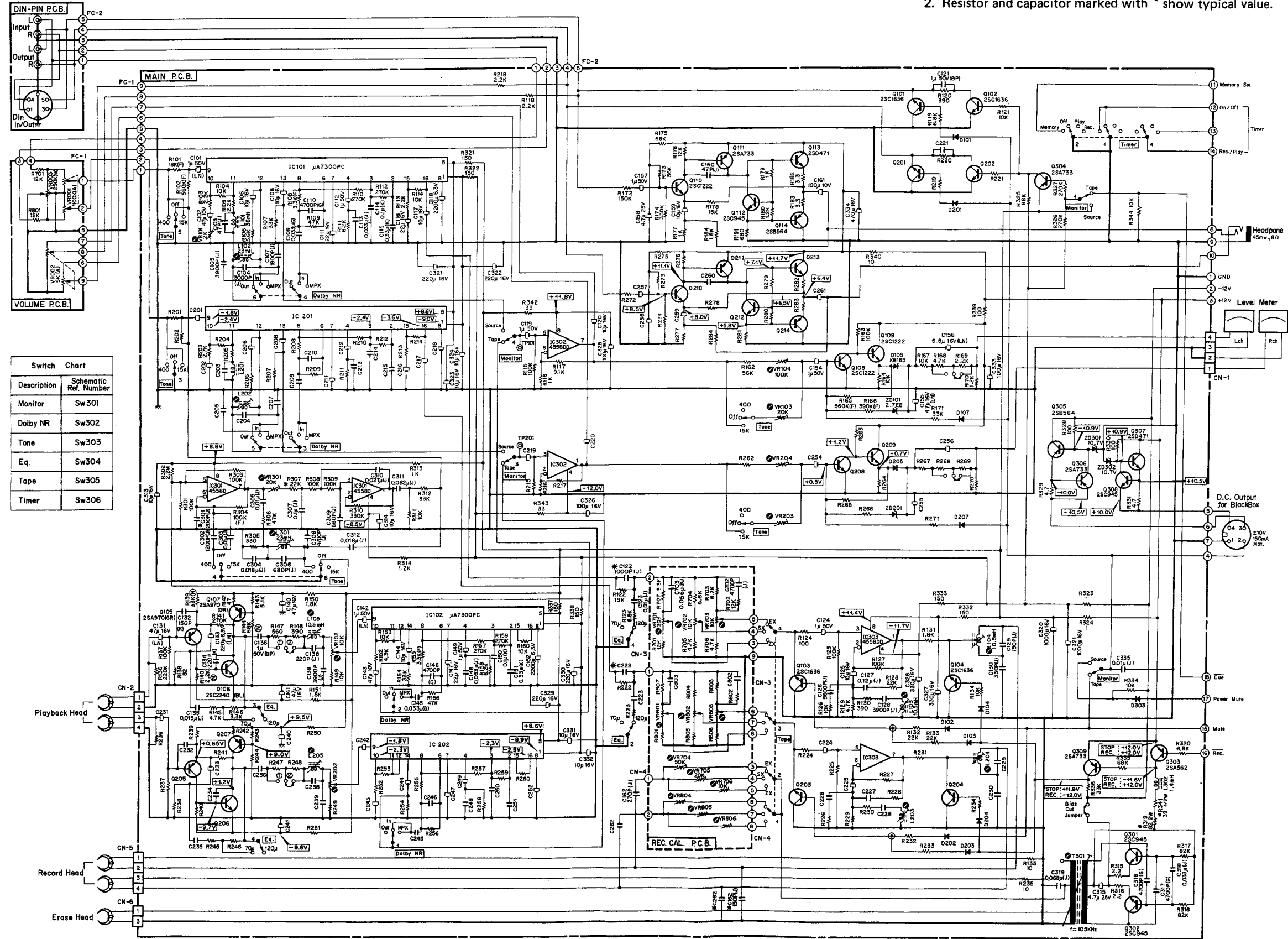

Fig. 14.1

14.2. Mechanism Control

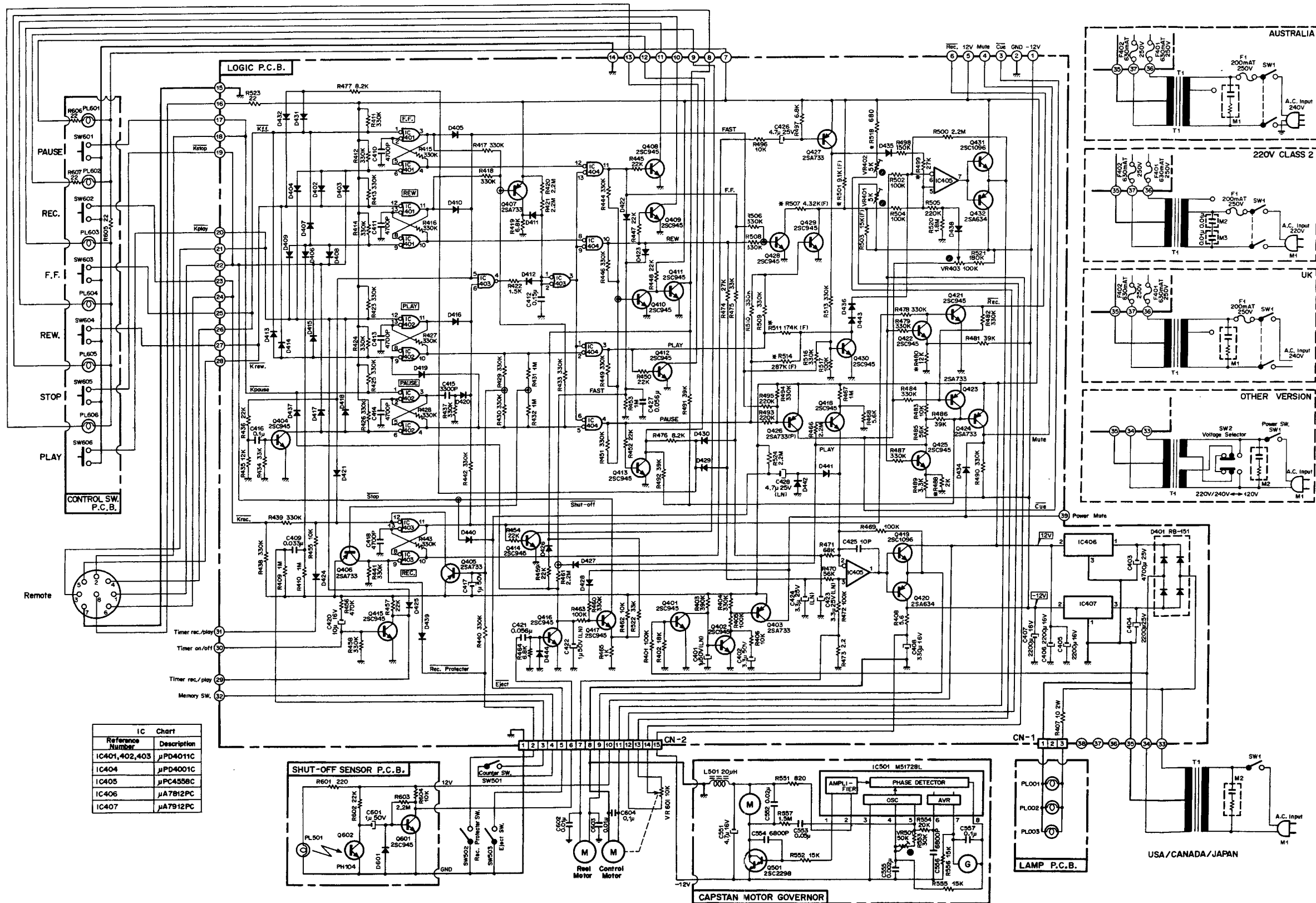
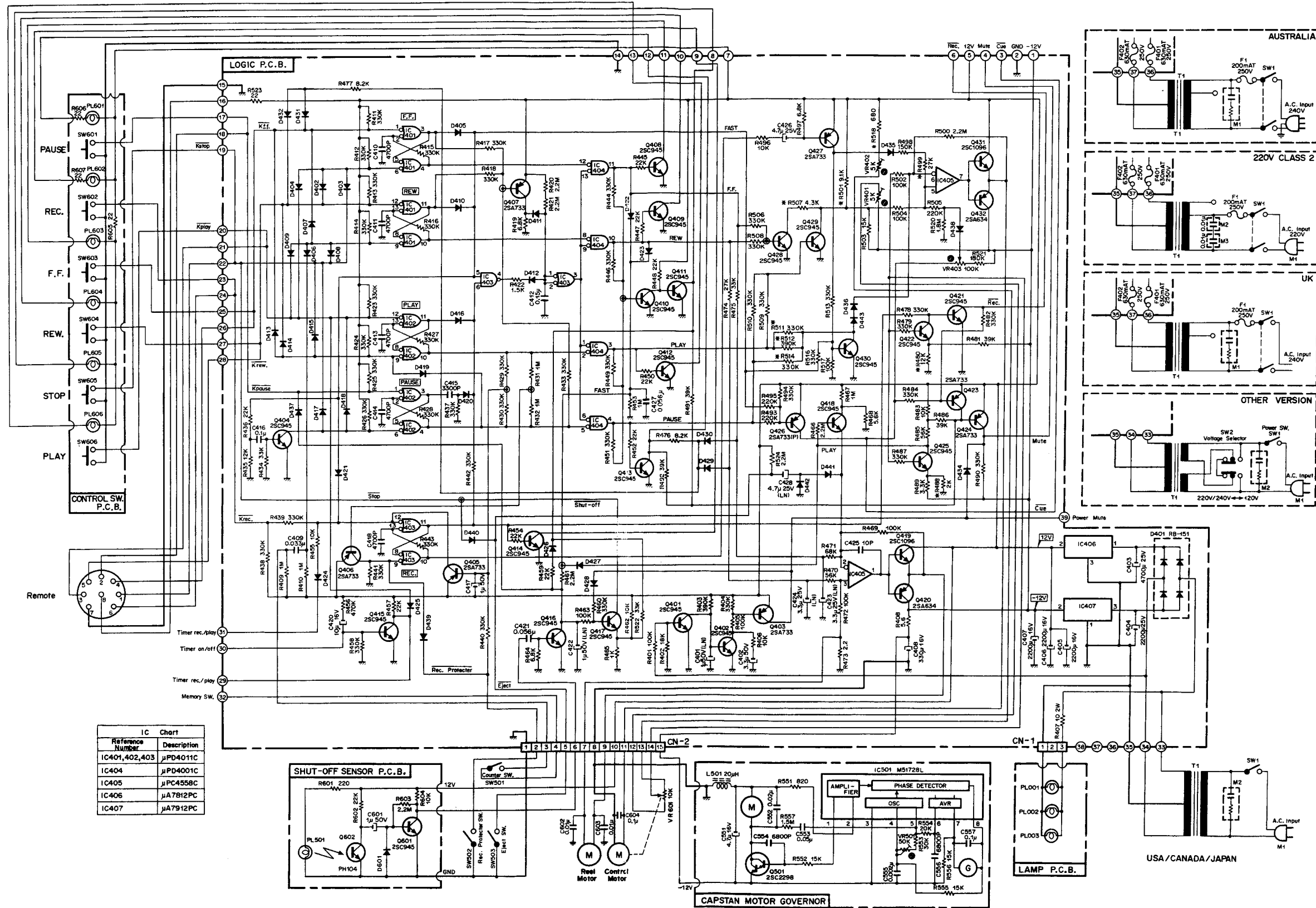

Fig. 14.2.1  
Serial No.: A11107951 -

Notes: 1. Diode is 1SS53, 1S953, or 1S1555 unless otherwise specified.  
2. Resistor marked with \* shows typical value.



Reference Number	Description
IC401,402,403	μPD4011C
IC404	μPD4001C
IC405	μPC4558C
IC406	μA7812PC
IC407	μA7912PC

Fig. 14.2.2  
Serial Nos.: A11105952 - A11107950

Notes: 1. Diode is 1SS53, 1S953, or 1S1555 unless otherwise specified.  
2. Resistor marked with \* shows typical value.



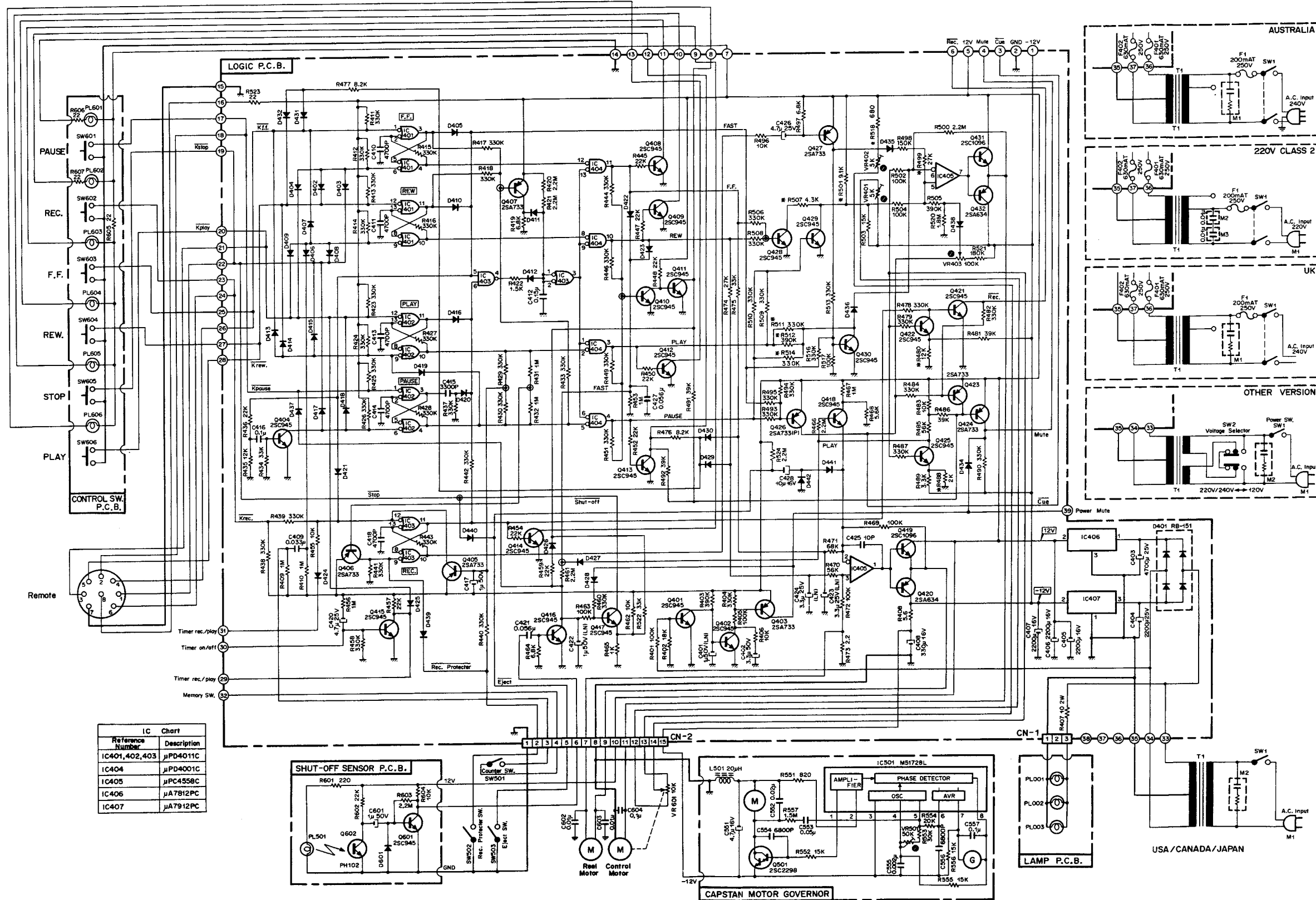

Fig. 14.2.3  
Serial Nos.: A11101001 - A11105951

Notes: 1. Diode is 1SS53, 1S953, or 1S1555 unless otherwise specified.  
2. Resistor marked with \* shows typical value.

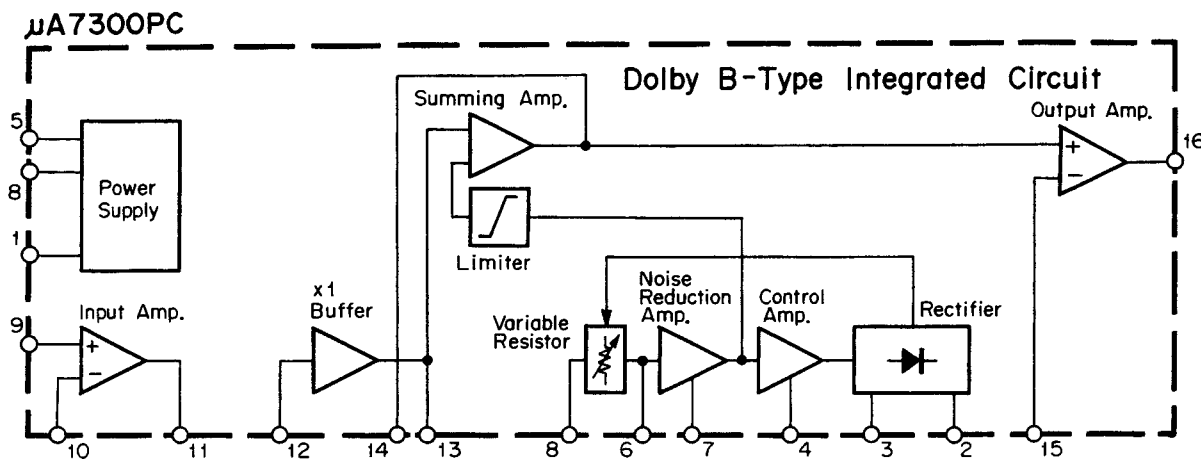

Fig. 14.3 Dolby NR IC  $\mu$ A7300PC

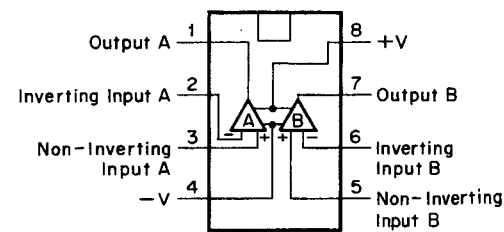

Fig. 14.4 Operational Amp. IC 4558

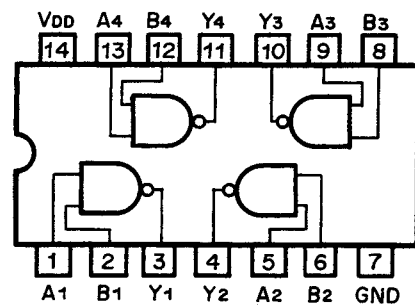

Fig. 14.5 C-MOS IC  $\mu$ PD4011C

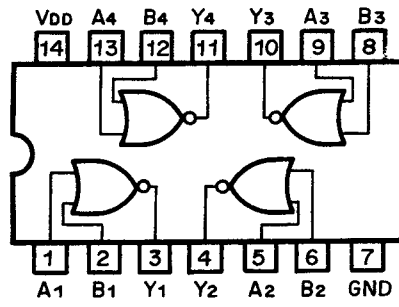

Fig. 14.6 C-MOS IC  $\mu$ PD4001C

15. REMOTE CONTROL UNIT RM-580 (OPTIONAL)

Refer to item 2.4, principle of operation of RM-580.

15.1. Mounting Diagrams

Note: Mounting diagram shows a dip side view of the printed circuit board.

15.1.1. Receiver

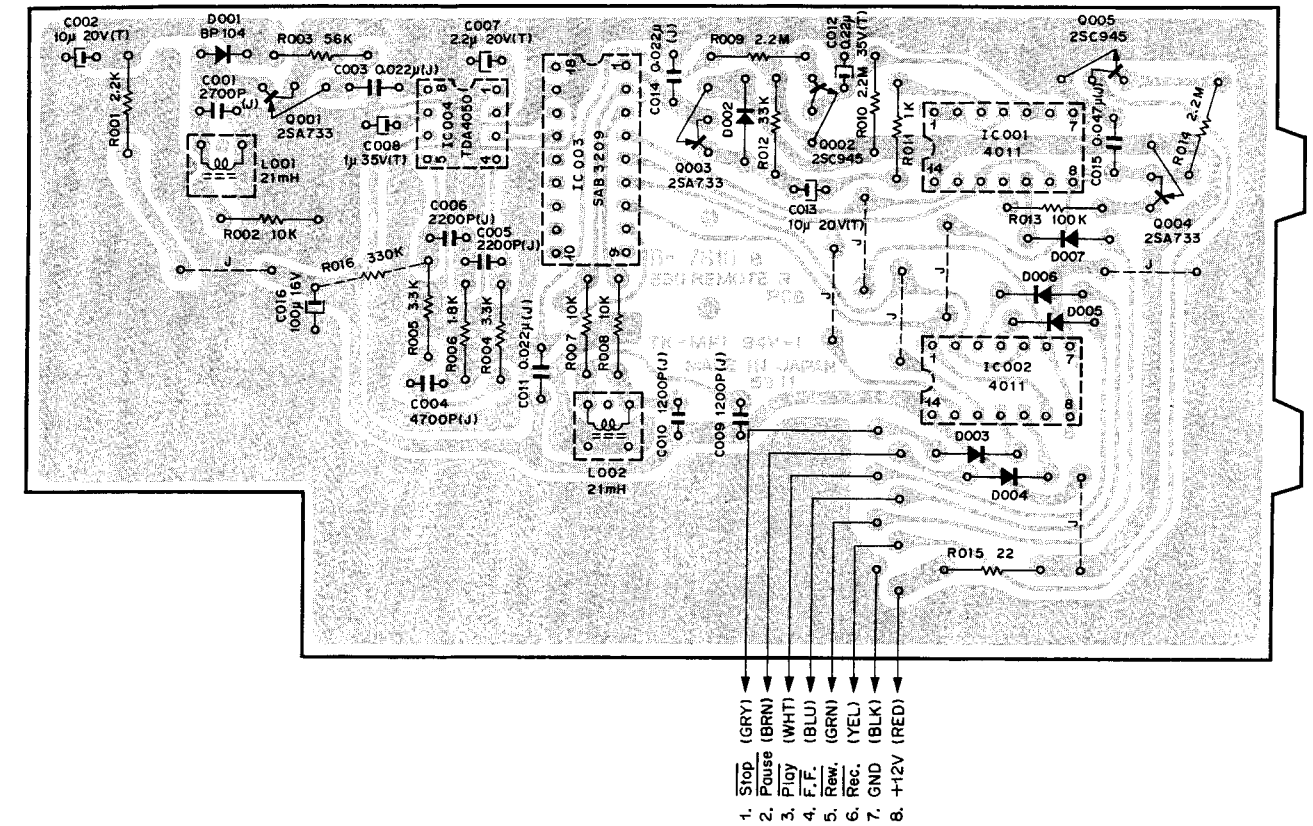

Fig. 15.1.1

Schematic Ref. No.	Part No.	Description	Schematic Ref. No.	Part No.	Description
	BA04002A	Remote Receiver P.C.B. Ass'y	R011	0B01857A	Carbon Resistor 1K ERD-25T J
			R012	0B05509A	Carbon Resistor 33K ERD-25T J
			R013	0B01889A	Carbon Resistor 100K ERD-25T J
			R015	0B05579A	Carbon Resistor 22 ERD-25T J
			R016	0B05627A	Carbon Resistor 330K ERD-25T J
IC001,002	0B06178A	IC $\mu$ PD4011C	C001	0B09231A	SP Capacitor 2700P 50V J
IC003	0B06162A	IC SAB3209	C002,013	0B05581A	Tantalum Capacitor 10 $\mu$ 20V
IC004	0B06163A	IC TDA4050	C003,011	0B09291A	Ceramic Capacitor 0.022 $\mu$ 50V J
Q001,003,004	0B06013A	Transistor 2SA733			
Q002,005	0B06100A	Transistor 2SC945	C004	0B05652A	Mylar Capacitor 4700P 50V J
D001	0B06165A	Photo Diode BP104	C005,006	0B01802A	Mylar Capacitor 2200P 50V J
D002,003,004,005,006,007	0B01909A	Silicon Diode 1S1555	C007	0B05598A	Tantalum Capacitor 2.2 $\mu$ 20V
L001,002	0B06588A	Coil 21mH	C008	0B05638A	Tantalum Capacitor 1 $\mu$ 35V
R001	0B05622A	Carbon Resistor 2.2K ERD-25T J	C009,010	0B05790A	SP Capacitor 1200P 50V J
R002,007,008	0B01888A	Carbon Resistor 10K ERD-25T J	C012	0B05772A	Tantalum Capacitor 0.22 $\mu$ 35V
R003	0B05508A	Carbon Resistor 56K ERD-25T J	C015	0B05796A	Mylar Capacitor 0.047 $\mu$ 50V J
R004,005	0B01681A	Carbon Resistor 3.3K ERD-25T J	C016	0B01400A	Electrolytic Capacitor 100 $\mu$ 16V
R006	0B05614A	Carbon Resistor 1.8K ERD-25T J		0B08610A	Shield Plate N604 (1 pce.)
R009,010,014	0B05671A	Carbon Resistor 2.2M ERD-25T J		0B03924A	Gate Pin (2 pcs.)

15.1.2. Transmitter

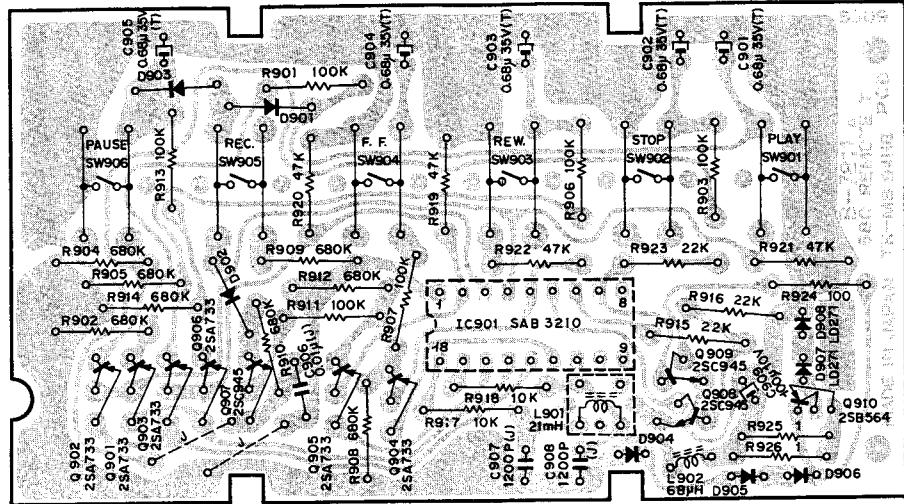

Fig. 15.1.2

Schematic Ref. No.	Part No.	Description
	BA04004A	Remote Transmitter P.C.B. Ass'y
IC901	OB07811A	Remote Transmitter P.C.B.
C901,902	OB06161A	IC SAB3210
903,904	OB06013A	Transistor 2SA733
905,906		
Q907,908	OB06100A	Transistor 2SC945
909		
Q910	OB06069A	Transistor 2SB564
D901,902	OB01909A	Diode 1S1555
903,904		
905,906		
D907,908	OB06164A	LED LD271
L901	OB06588A	Coil 21mH
L902	OB06561A	Inductor 68μH
R901,903	OB01889A	Carbon Resistor 100K ERD-25T J
906,907		
911,913		
R902,904	OB05868A	Carbon Resistor 680K ERD-25T J
905,908		
909,910		
912,914		
R915,916	OB05615A	Carbon Resistor 22K ERD-25T J
923		
R917,918	OB01888A	Carbon Resistor 10K ERD-25T J
R919,920	OB05641A	Carbon Resistor 47K ERD-25T J
921,922		
R924	OB01679A	Carbon Resistor 100 ERD-25T J
R925,926	OB05695A	Carbon Resistor 1 ERD-25T J
C901,902	OB05773A	Tantalum Capacitor 0.68μ 35V
903,904		
905		
C906	OB09290A	Ceramic Capacitor 0.01μ 50V J
C907,908	OB05790A	SP Capacitor 1200P 50V J
C909	OB05885A	Electrolytic Capacitor 100μ 10V
SW901,902	OB07219A	Switch AKC8S
903,904		
905,906		

15.2. Schematic Diagrams

15.2.1. Receiver

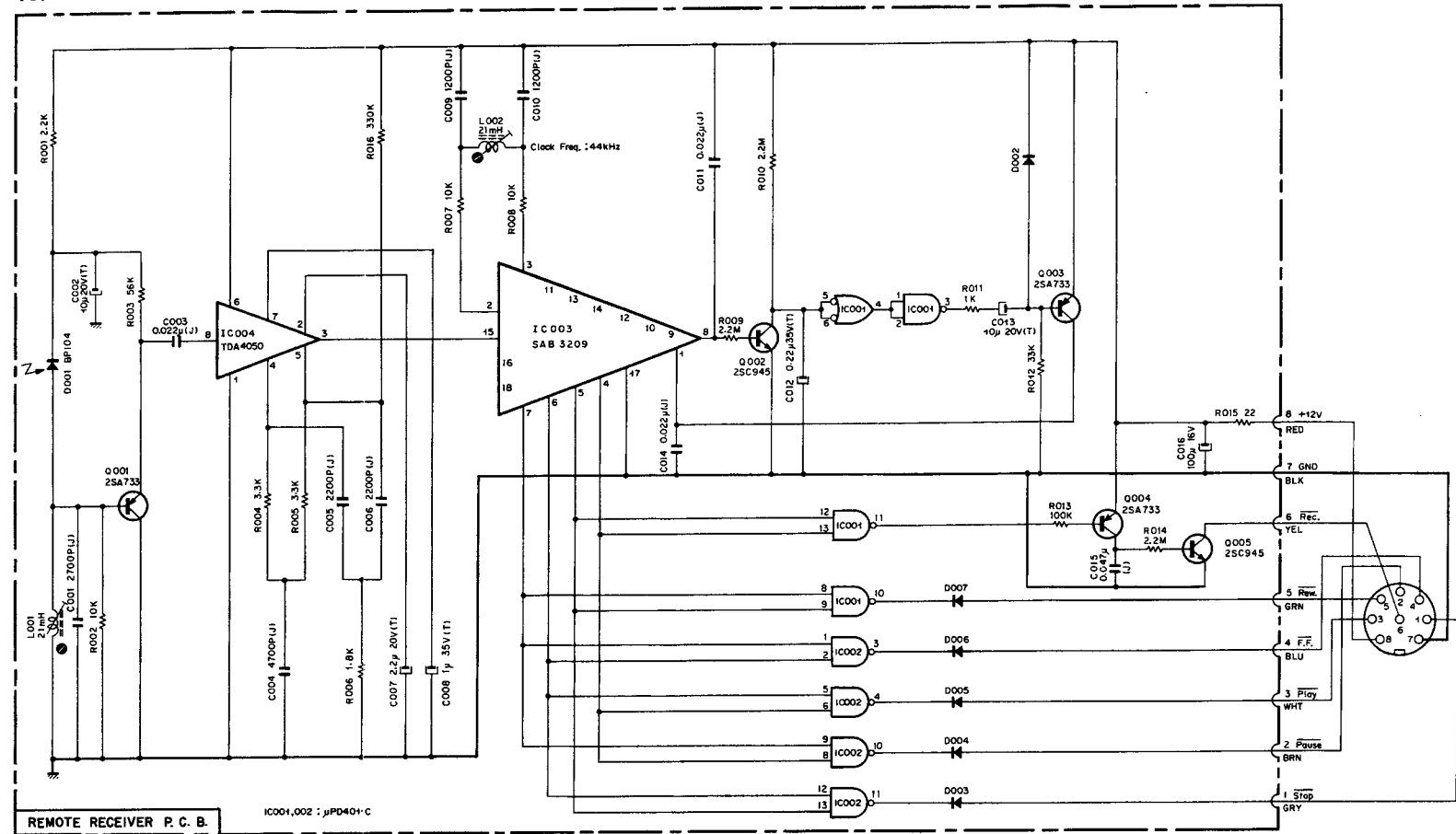

Fig. 15.2.1

15.2.2. Transmitter

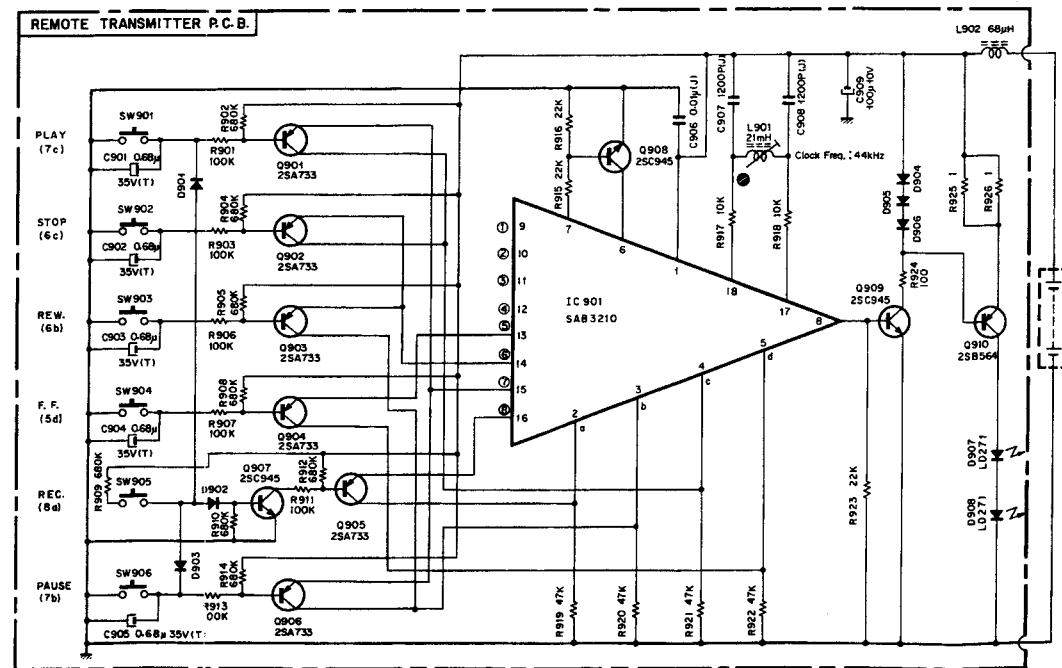

Fig. 15.2.2

15.3. Adjustments

15.3.1. Transmitter

- (1) Disassemble the Bottom Case, then remove the Remote Transmitter P.C.B. Ass'y.
- (2) Supply +9 V DC from an external Regulated Power Supply to the DC line of the Remote Transmitter P.C.B. Ass'y.
- (3) Connect a Frequency Counter across the IC901-18 pin and ground.
- (4) Push the Play Microswitch (SW901) to turn ON the power.
- (5) Adjust Coil L901 to obtain 44 kHz  $\pm$  50 Hz on the Frequency Counter.
- (6) Release the Play Microswitch (SW901), then remove the Regulated Power Supply and the Frequency Counter.
- (7) Assemble the Remote Transmitter Ass'y.

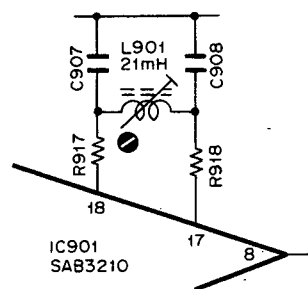

Fig. 15.3.1

15.3.2. Receiver

- (1) Disassemble the Receiver Case, then remove the Remote Receiver P.C.B. Ass'y.
- (2) Supply +12 V DC to the Remote Receiver P.C.B. Ass'y from an external Regulated Power Supply by connecting +12 V DC of the Regulated Power Supply to pin No.8 (RED) of the Remote Cord and ground to pin No. 7 (BLACK), or from the N-582 by plugging Remote Cord into Remote Control Socket of the N-582.
- (3) Connect a Frequency Counter across the IC003 (SAB3209)-2 pin and ground.
- (4) Adjust Coil L002 to obtain 44 kHz  $\pm$  50 Hz on the Frequency Counter.

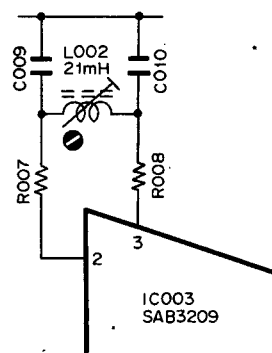

Fig. 15.3.2

- (5) Insert a 1-M $\Omega$  resistor in series to the Oscillator output, then connect it across the base of Q001 and ground.
- (6) Set the output of the Oscillator to the order of a few voltage, then calibrate the oscillator frequency to 22 kHz  $\pm$  25 Hz monitoring the frequency by the Frequency Counter.
- (7) Connect an AC Voltmeter across the emitter of Q001 and ground.
- (8) Adjust Coil L001 to obtain maximum reading on the AC Voltmeter.
- (9) Remove the Oscillator, AC Voltmeter and Regulated Power Supply, then assemble the Remote Receiver Ass'y.

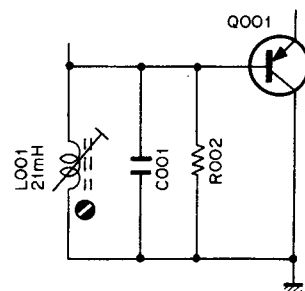

Fig. 15.3.3

15.3.3. Performance Check of Transmitter and Receiver

- (1) Connect the Receiver to the Remote Control Socket of the N-582.
  - (2) Press each control switch of the Transmitter and check to insure whether every function operates accurately.
- Note: Possible operating zone of the Transmitter is shown in Fig. 15.3.4.

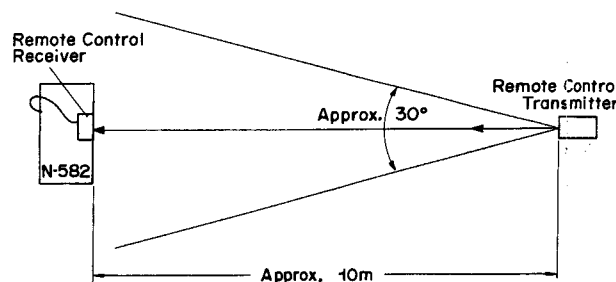

Fig. 15.3.4

15.4. Mechanism Ass'y and Parts List

15.4.1. Receiver

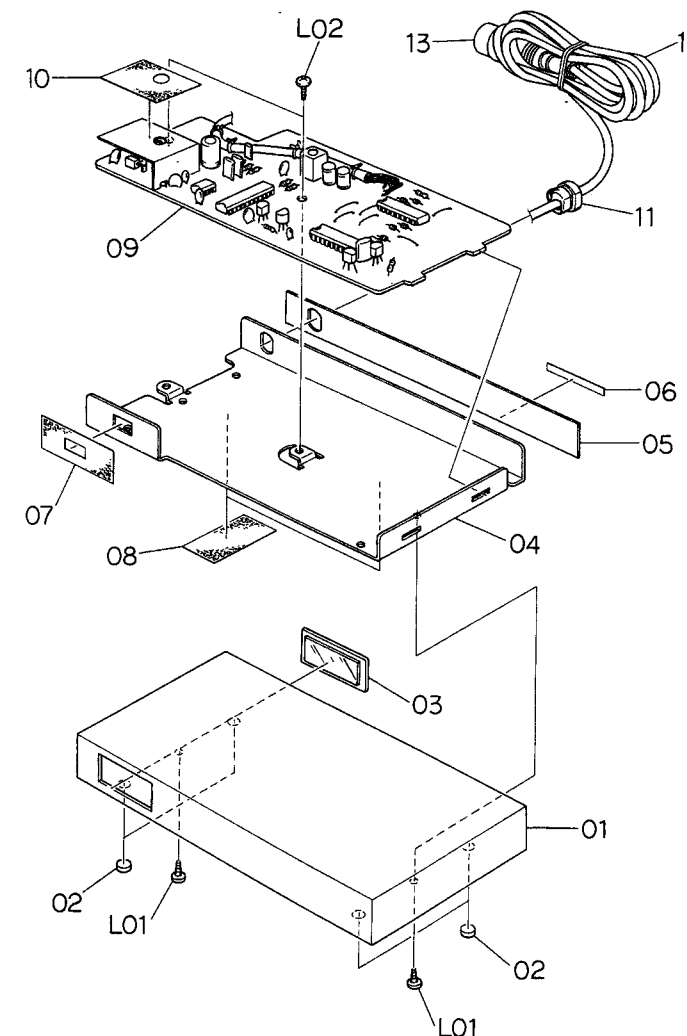

Fig. 15.4.1

Schematic Ref. No.	Part No.	Description	Q'ty
<b>Remote Receiver Ass'y</b>			
01	0H03702B	Receiver Case	1
02	0A03285B	Leg RM 580	4
03	0H03649A	Acrylic Cover	1
04	0J03995B	Receiver Chassis	1
05	0M03975D	Rear Plate	1
06	0M03982A	Serial No. Seal (Receiver)	1
07	0J03996A	Chassis Mask	1
08	0J04008A	Chassis Himelon	2
09	BA04002A	Remote Receiver P.C.B. Ass'y	1
10	0J04007A	P.C.B. Himelon	1
11	0B08587A	Cord Bushing	1
12	0B05222B	8P Cord	1
13	0B08585A	8P DIN Plug	1
L01	0E00860A	BT Screw M3x6 Philips Binding Head (Bronze)	2
L02	0E00857A	BT Screw M3x6 Philips Binding Head	2

15.4.2. Transmitter

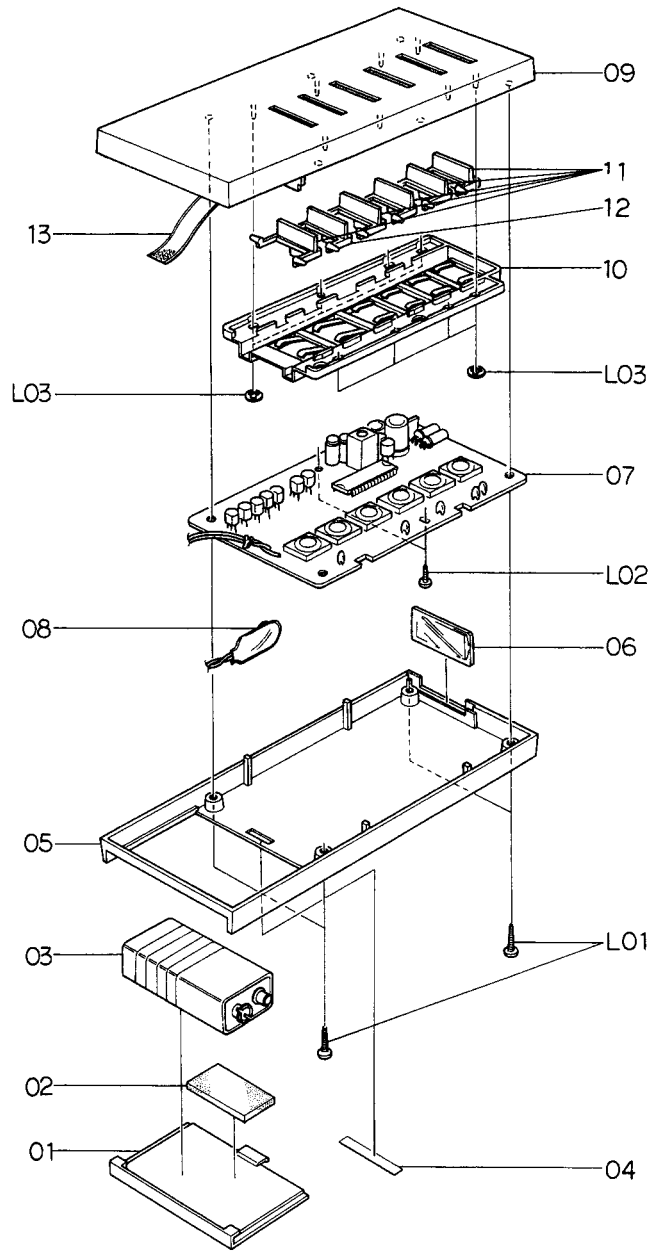

Fig. 15.4.2

Schematic Ref. No.	Part No.	Description	Q'ty	Schematic Ref. No.	Part No.	Description	Q'ty
		<b>Remote Transmitter Ass'y</b>		10	0J03994B	Spring Plate	1
01	0H03705A	Battery Cover	1	11	0H03659A	Control Button B	5
02	0J03905A	Battery Cushion	1	12	0H03658A	Control Button A	1
03	0B08529A	Battery 9V	1	13	0J03906A	Battery Ribbon	1
04	0M03976A	Serial No. Seal (Transmitter)	1	L01	0E00825A	BT Screw M2.6x8 Philips Binding Head	4
05	0H03704A	Bottom Case	1	L02	0E00824A	BT Screw M2.6x6 Philips Pan Head	2
06	0H03657A	Smoked Filter	1	L03	0E00874A	Stopper Ring CS 2mm	8
07	BA04004A	Remote Transmitter P.C.B. Ass'y	1				
08	0B05223B	Battery Snap B 110mm	1				
09	0H03701C	Top Case	1				

## 16. SPECIFICATIONS

Power Source . . . . .	100, 120, 120/220-240, 220 or 240 V; 50/60 Hz
Power Consumption . . . . .	27 W Max.
Tape Speed . . . . .	1-7/8 ips. (4.8 cm/sec.) $\pm 0.5\%$
Wow and Flutter . . . . .	Less than 0.1% WTD Peak, 0.05% WTD rms
Frequency Response . . . . .	20-20,000 Hz $\pm 3$ dB ( $-20$ dB Rec. Level)
Signal to Noise Ratio . . . . .	Better than 60 dB at 400 Hz, 0 dB, WTD rms
(Dolby NR In, 70 $\mu$ s)	Better than 66 dB at 400 Hz, 3% THD, WTD rms
Total Harmonic Distortion . . . . .	Less than 0.8% at 400 Hz, 0 dB (ZX Tape)
	Less than 1.0% at 400 Hz, 0 dB (SX, EXII Tapes)
Erase . . . . .	Better than 60 dB below saturation level at 1 kHz
Separation . . . . .	Better than 37 dB at 1 kHz, 0 dB
Crosstalk . . . . .	Better than 60 dB at 1 kHz, 0 dB
Bias Frequency . . . . .	105 kHz
Input . . . . .	50 mV, 50 k ohms
Output Level . . . . .	1 V (400 Hz, 0 dB, Output Level at Max.) 2.2 k ohms
Headphone . . . . .	45 mW
DC Output Jack . . . . .	$\pm 10$ V 125 mA Max.
Dimensions . . . . .	500(W) x 130(H) x 350(D) m/m
	19-11/16(W) x 5-1/8(H) x 13-25/32(D) inches
Approximate Weight . . . . .	8.3 kg. 18 lb 5 oz

- Specifications and appearance design are subject to change for further improvement without notice.
- Dolby NR under license from Dolby Laboratories.
- The word "DOLBY" and the Double-D-Symbol are trademarks of Dolby Laboratories.