

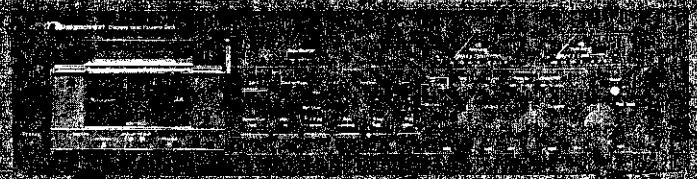

Service Manual

Nakamichi 581

Discrete Head Cassette Deck



CONTENTS

1. General	3
2. Principle of Operation	5
2. 1. Mechanisms	5
2.1.1. 3-Head Configuration	5
(1) Playback Head	5
(2) Record Head	6
(3) Erase Head	6
(4) Headblock	6
2.1.2. Double Capstan Tape Drive	7
2.1.3. Mechanism Control Cam Operation	8
2. 2. Amp. Circuits	9
2.2.1. Playback Eq. Amp. Circuit	9
2.2.2. Record Amp. Circuit	11
2.2.3. Bias Osc. Circuit	11
2.2.4. Test Tone Circuit	12
2. 3. Mechanism Control Circuits	13
2.3.1. Logic Control	13
(1) C-MOS IC	13
(2) Logic Control and Other Circuits	15
2.3.2. Shut-off Sensor and Detector	20
2.3.3. Control Motor Drive Circuit	21
2.3.4. Capstan Motor Governor	22
2.3.5. Reel Motor Governor	23
2. 4. Remote Control Unit RM-580 (Optional)	24
2.4.1. Introduction	24
2.4.2. Transmitter	24
2.4.3. Receiver	25
3. Removal Procedures	27
3. 1. Acrylic Cassette Compartment Cover	27
3. 2. Top Cover Ass'y	27
3. 3. Bottom Cover Ass'y	27
3. 4. Front Panel Ass'y	27
3. 5. Mechanism Ass'y	27
3. 6. Main P.C.B. Ass'y	28
3. 7. Logic P.C.B. Ass'y	28
3. 8. Power Switch	28
3. 9. Volume P.C.B. Ass'y	28
3. 10. Control Button Ass'y	28
3. 11. Record Cal. P.C.B. Ass'y	28
3. 12. Meter Ass'y	29
3. 13. Lamp P.C.B. Ass'y	29
3. 14. Aluminum Mirror	29
3. 15. Rear Panel Ass'y	29
3. 16. Power Transformer	29
3. 17. Cassette Case Ass'y	29
3. 18. Cover Plate	30
3. 19. Tape Counter Ass'y	30
3. 20. Capstan Motor Ass'y and Flywheel Ass'y	31
3. 21. Sub Mechanism Chassis Ass'y	31
3. 22. Control Motor Ass'y	31
3. 23. Reel Motor Ass'y	31
3. 24. Cam Control Volume	31
3. 25. Reel Hub Ass'y	31
3. 26. Idler Ass'y	31
3. 27. Cam Drive Gear and Control Cam	31
3. 28. Head Mount Base Ass'y	31

3. 29.	Supply Pressure Roller Ass'y	32
3. 30.	Erase Head	32
3. 31.	Take-up Pressure Roller Ass'y	32
3. 32.	Playback Head Ass'y	32
3. 33.	Record Head Ass'y	32
4.	Measurement Instruments	33
5.	Mechanical Adjustments	34
5. 1.	Mechanism Control Cam Adjustment	34
5. 2.	Tape Speed Adjustment	35
5. 3.	Record Head and Playback Head Tilt Adjustment	35
5. 4.	Head Base Stroke Adjustment in Play and Cue Modes	37
5. 5.	Tape Guides Adjustment and Erase Head Stroke Adjustment	38
5. 6.	Erase Head Height and Tilt Adjustment	39
5. 7.	Record Head and Playback Head Height Adjustment and Azimuth Alignment	40
5. 8.	Record Head Stroke Adjustment	41
5. 9.	Tape Travelling Adjustment	42
5. 10.	Record Switch Linkage Adjustment	42
5. 11.	Flywheel Holder Adjustment	43
5. 12.	Eject Wire Adjustment	43
5. 13.	Control Button Stroke Adjustment	44
5. 14.	Lubrication	44
6.	Electrical Adjustments and Measurements	45
6. 1.	Current Type	45
6.1.1.	Parts Location for Electrical Adjustment	45
6.1.2.	Electrical Adjustments and Measurements	46
	(1) Adjustment and Measurement Instructions	46
	(2) Frequency Response Adjustment	50
	(3) Dolby NR Circuit Check	50
6. 2.	Previous Type	51
6.2.1.	Parts Location for Electrical Adjustment	51
6.2.2.	Electrical Adjustments and Measurements	52
	(1) Adjustment and Measurement Instructions	52
	(2) Frequency Response Adjustment	55
	(3) Dolby NR Circuit Check	55
7.	Mounting Diagrams and Parts List	56
7. 1.	Control Switch P.C.B. Ass'y	56
7. 2.	Volume P.C.B. Ass'y	56
7. 3.	DIN-Pin P.C.B. Ass'y	56
7. 4.	Shut-off P.C.B. Ass'y	56
7. 5.	Record Cal. P.C.B. Ass'y	56
7. 6.	Main P.C.B. Ass'y	57
7. 7.	Logic P.C.B. Ass'y	61
7. 8.	Lamp P.C.B. Ass'y	65
8.	Mechanism Ass'y and Parts List	67
8. 1.	Synthesis	67
8. 2.	Synthesis Mechanism 581 (A01)	68
8. 3.	Front Panel Ass'y 581 (B01)	68
8. 4.	Headphone Jack Ass'y (B02)	68
8. 5.	Mechanism Ass'y 581 (B03)	69
8. 6.	Chassis Ass'y 581 (B04)	69
8. 7.	Lamp House Cover Ass'y (C01)	72
8. 8.	Flywheel Holder Ass'y (D01)	72
8. 9.	Sub Mechanism Chassis Ass'y (D02)	72
8. 10.	Main Mechanism Chassis Ass'y (D03)	73
8. 11.	Rear Panel Ass'y (E01)	75
8. 12.	Reel Motor Ass'y (F01)	76

8. 13.	Control Motor Ass'y (F02)	76
8. 14.	Head Mount Base Ass'y (F03)	76
8. 15.	Supply Pressure Roller Ass'y (F04)	77
8. 16.	Take-up Pressure Roller Ass'y (F05)	77
8. 17.	Head Base Ass'y B (F06)	77
8. 18.	Cassette Case Holder L Ass'y (F07)	77
8. 19.	Cassette Case Holder R Ass'y (F08)	77
8. 20.	Auto Shut-off Ass'y (F09)	77
8. 21.	Pneumatic Damper Ass'y (F10)	78
8. 22.	P-8L Playback Head Ass'y (G01)	79
8. 23.	R-8L Record Head Ass'y (G02)	79
9.	Overall Timing Chart	79
10.	Eq. Amp. Frequency Response	80
10. 1.	Playback Frequency Response	80
10. 2.	Record Current Frequency Response	80
11.	Wiring Diagram	81
12.	Block Diagrams	83
12. 1.	Amplifier	83
12. 2.	Mechanism Control	85
13.	Schematic Diagrams	86
13. 1.	Amplifier	86
13. 2.	Mechanism Control	88
14.	Remote Control Unit RM-580 (Optional)	91
14. 1.	Mounting Diagrams and Parts List	91
14.1.1.	Receiver	91
14.1.2.	Transmitter	92
14. 2.	Schematic Diagrams	92
14.2.1.	Receiver	92
14.2.2.	Transmitter	92
14. 3.	Adjustments	93
14.3.1.	Transmitter	93
14.3.2.	Receiver	93
14.3.3.	Performance Check of Transmitter and Receiver	93
14. 4.	Mechanism Ass'y and Parts List	93
14.4.1.	Receiver	93
14.4.2.	Transmitter	94
15.	Specifications	95

1. GENERAL

1.1. Control Functions

Nakamichi 581 control functions are shown below:

- | | |
|---|--|
| 1. Acrylic Cassette Compartment Cover | 11. Test Tone Switch (400 Hz/15 kHz) |
| 2. Cassette Lid | 12. Dolby NR/MPX Filter Switch |
| 3. Eject Button | 13. Power Switch |
| 4. Counter Reset Button | 14. Peak Level Meters |
| 5. Tape Counter | 15. Input Level Control (Record Level) |
| 6. Bias Adjustment Controls | 16. Balance Control |
| 7. Record Calibration Controls | 17. Output Level Control |
| 8. Tape Start Memory/Timer Switch | 18. Play Button |
| 9. Tape Switch (EX/SX/ZX) | 19. Stop Button |
| 10. Eq. Switch (120 μ s/70 μ s) | 20. Rewind Button |

- 21. Fast-Forward Button
- 22. Record Button
- 23. Pause/Cue Button
- 24. Head Height and Azimuth Alignment Screws
- 25. Headphone Jack
- 26. Input Jacks
- 27. DIN In/Out Connector
- 28. Output Jacks
- 29. DC Output Jack
- 30. Remote Control Socket
- 31. Voltage Selector
- 32. Power Cord

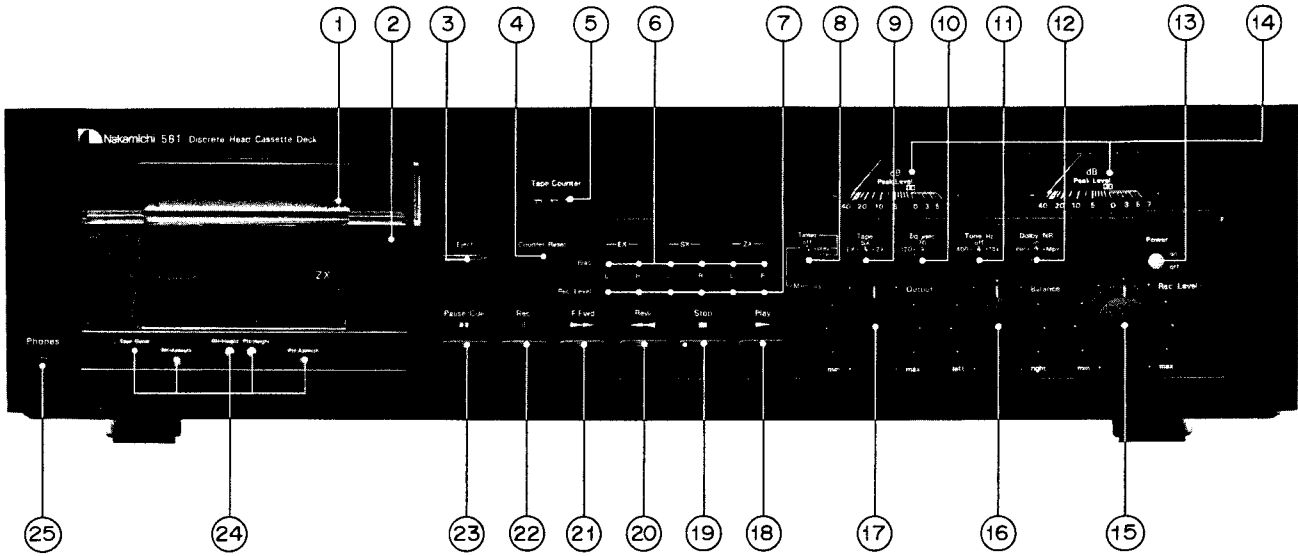

Fig. 1.1 Front View

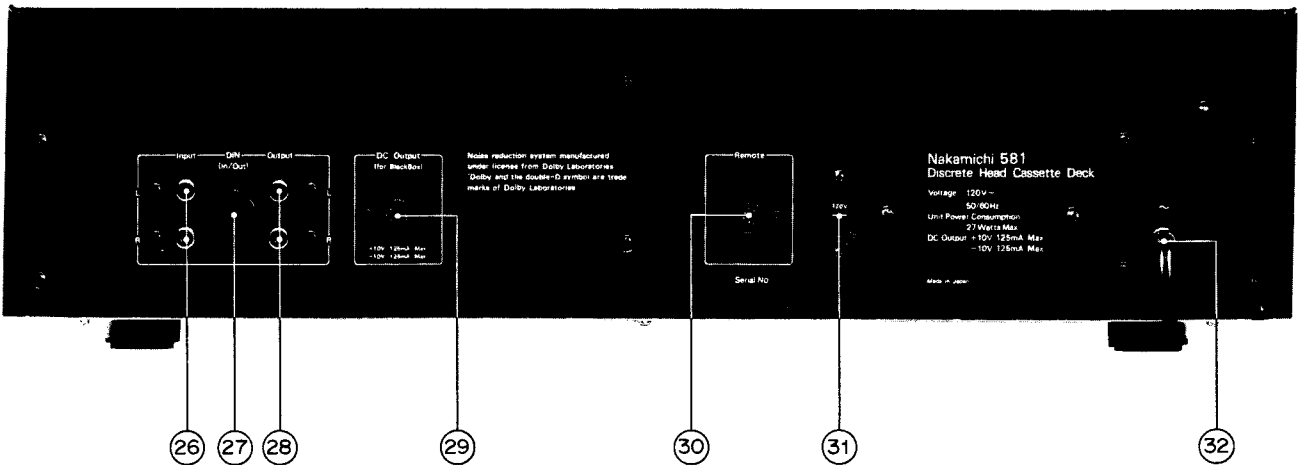

Fig. 1.2 Rear View

1.2. Voltage Selector

Voltage selector is installed on the rear panel for other versions of the Nakamichi 581. This voltage selector can select either 120 V or 220 – 240 V at customer's disposal.

2. PRINCIPLE OF OPERATION

2.1. Mechanisms

2.1.1. 3-Head Configuration

N-581 is a Discrete Head Cassette Deck which contains a Playback Head, Record Head and Erase Head within a double-capstan closed-loop. Since it contains three heads, with narrow gap for Playback Head and wide gap for Record Head, N-581 has excellent playback and recording characteristics. Three Heads, because they are installed in the double-capstan closed-loop, can result adequate tape tension and stable tape drive.

Accuracy of tape travel is one of the most essential factors for a device to optimize its performance. Inaccurate tape travel will therefore induce deterioration exemplified by the following:

- (a) vibration will be given to tape travel, as a result of which flutter and modulation noise will become increased
- (b) insufficient tape-to-head contact will result in level drops
- (c) tape skew will become greater and frequency response will become decreased

Needless to say, constant tape travel must consist of smooth drive mechanism, as well as of the fact that tape, heads and tape guide are placed in the most appropriate positions.

(1) Playback Head

Even if an azimuth misalignment is noted because of tape skew, deterioration of performance has been greatly reduced upon decreasing the gap of the Playback Head to narrow. The gap of this Playback Head is 0.9 micron. Where gap width is decided to be d , it is publicly known that the gap loss L_d is obtained by the following formula:

$$L_d = 20 \log \frac{\sin \frac{\pi d}{\lambda}}{\frac{\pi d}{\lambda}} \text{ (dB)}$$

Legend: d = Gap width of Playback Head
 λ = Recording wave length
 $(\lambda = v/f, v = \text{Tape speed})$

The Playback Head employed a narrower gap, and is of crystal permalloy (same as SuperHead which is used in N-600II and N-580). The narrower gap head resulted in decreasing loss against frequencies at highs and an improvement of frequency response.

Where there should be any azimuth misalignment, it would equivalently be converted to gap loss and will give affect to frequency response.

Fig. 2.1.1 shows equivalent gap width, Fig. 2.1.2 azimuth misalignment at frequency of 20 kHz vs azimuth loss (playback output loss) when gap width is considered to be a parameter, and Fig. 2.1.3 shows frequency vs azimuth loss when azimuth misalignment is considered to be a parameter.

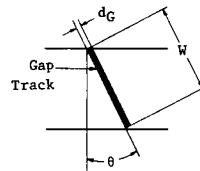

$$\text{Loss} = 20 \log \frac{\sin \frac{\pi d}{\lambda}}{\frac{\pi d}{\lambda}} \text{ (dB)}$$

$\lambda = v/f = \text{Tape Speed}/20 \text{ kHz} = 2.375 \mu\text{m}$
 $d \approx d_G + W \sin \theta$
 d_G : Gap Width = $0.9/1.5 \mu\text{m}$
 W : Track Width = $600 \mu\text{m}$

Fig. 2.1.1 Equivalent Gap Width

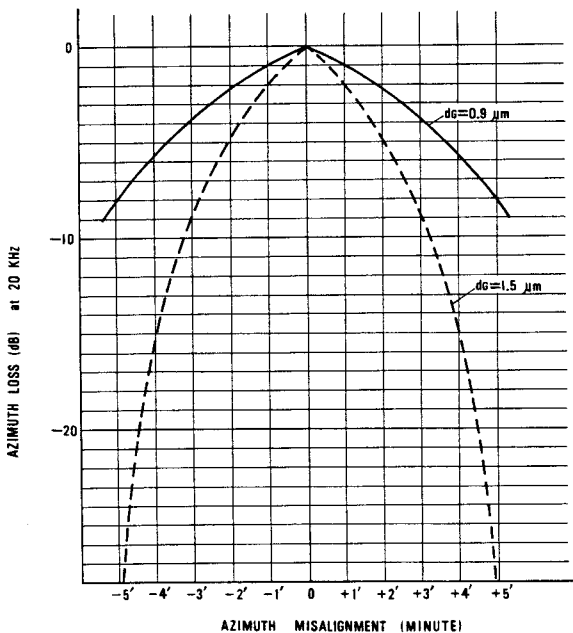

Fig. 2.1.2 Azimuth Misalignment vs Azimuth Loss (Playback Output Loss) at 20 kHz

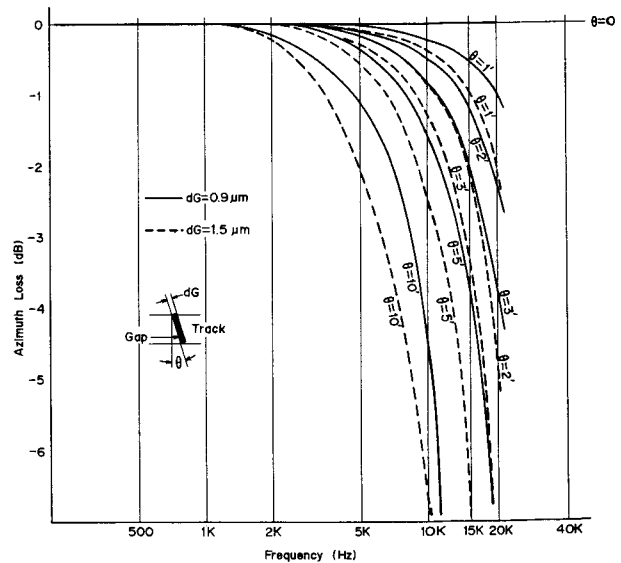

Fig. 2.1.3 Frequency vs Azimuth Loss

(2) Record Head

N-581 Record Head is of crystal permalloy, same material as Playback Head's, but with the gap of 3 microns. In order to reduce the distance between Playback Head and Record Head, the latter is made very small. Further it is designed to bring the gap out of center. Also, the surface of the latter is made not symmetrical in shape. All these bring about excellent effect in tape travel and recording characteristic.

(3) Erase Head

Fig. 2.1.4 shows the sectional view of Erase Head. Fig. 2.1.5 shows the characteristics of erasing current and erasure. It has the same characteristics with N-580's Direct-Flux Erase Head but been purposely developed to minimize the size further. Conventional Erase Head had its inside core narrower than its outside core, while this Erase Head is equipped with an inside core wider than the outside core. This has resulted more power sufficient enough for erasing even Metal Tape with small power consumption, approx. 0.5 W, though the head width is as small as 3 mm. The smaller the power consumption is, the smaller will be the heat generation, and this is of course another merit.

(4) Headblock

Refer to Fig. 2.1.6. N-581 Playback Head and Record Head, they are both made small in size so that the both heads are assembled in a space of the conventional Record/Playback Head. Erase Head is located at the place where the Record Head is located in the N-70011/100011. Both Playback Head and Record Head are assembled on the Head Mount Base. Take-up Tape Guide and Supply Tape Guide are fixed to the Take-up Pressure Roller Arm and Supply Pressure Roller Arm, respectively. Erase Head is placed on the Head Base. All these can be separately adjusted. Record Head is placed slightly backward, approximately 0.15 mm away from the Playback Head. Record Head is placed approximately 3° inclined leftward. Shape of the Heads and its location have been carefully studied to bring about smoother contact of tape with the Heads. Pad Lifter is affixed to the Playback Head so as not to let Tape Pad touch the Head to give more stabilized tape travel, making it free from the influence of the Tape Pad within the Cassette Tape. Thus the trouble of changes in azimuth can now be avoided at changing of cassette tape, if only the Record Head azimuth is properly adjusted in advance. The Fig. 2.1.7 shows trackings of each head against a tape of the N-581, wherein the figure shows ideal locations at the time of designing, thus the tracking in actual use will vary more or less, depending upon the tape width, etc.

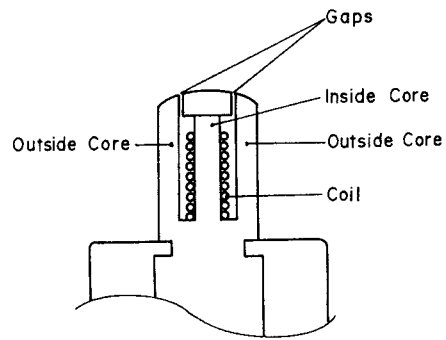

Fig. 2.1.4 Sectional View of Erase Head

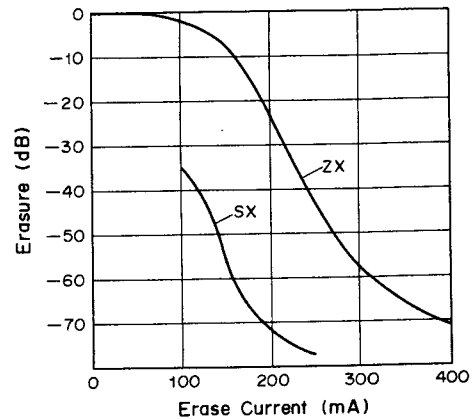

Fig. 2.1.5 Characteristics of Erasing Current and Erasure

(a) Adjustment of Tape Guide Height

Tape Guide of the N-581 is assembled into the Take-up and Supply Pressure Roller Assemblies. With a spring in the stud of Mechanism Chassis Ass'y, Pressure Roller Ass'y is tightly affixed with Tape Guide Adjustment Nut. The Adjustment Nut is placed on a spring through Pressure Roller Arm, and therefore by either tightening or loosening adjustment the height of the Tape Guide will become possible.

(b) Playback Head Height Adjustment and Azimuth Alignment

Azimuth and height of Playback Head can be made independently and adjustment may be done separately without affecting others. In order to adjust the tilt of Playback Head backwards or frontwards, take off the Height Gear Stopper and take out the Height Gear and then turn the two Height Adjustment Screws. After the adjustment is done, place the Height Gear back and fix it with the Height Gear Stopper. After the tilt is adjusted in such a way as above, adjust the height by loosening or tightening the Height Gear. Azimuth alignment is adjusted by loosening or tightening the PH Azimuth Screw. This system has been carefully designed so as to minimize influence each other between azimuth and height adjustment.

(c) Record Head Height Adjustment and Azimuth Alignment

Record Head tilt adjustment can be performed in the same way as for the Playback Head.

Height adjustment can be adjusted while recording 400 Hz test tone by loosening or tightening RH Height Adjustment Screw to obtain the maximum level on the both Level Meters. Azimuth alignment can be adjusted while playing back 15 kHz test tone by loosening or tightening RH Azimuth Alignment Screw to obtain the maximum level on the both Level Meters.

This system has also been carefully designed so as to minimize influence each other between azimuth and height adjustment.

(d) Erase Head Height and Tilt Adjustment

Erase Head is affixed onto the Erase Head Plate which is assembled with the Head Base. It is installed with three screws. By turning these screws, its height, tilt of backward or frontward, and tilt of leftward or rightward can be adjusted separately, thus the best location of Erase Head can be obtained.

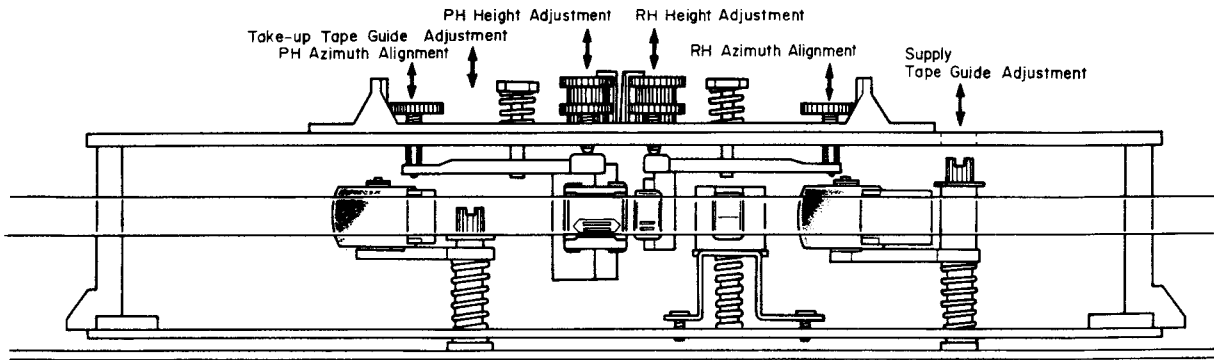

Fig. 2.1.6 Headblock

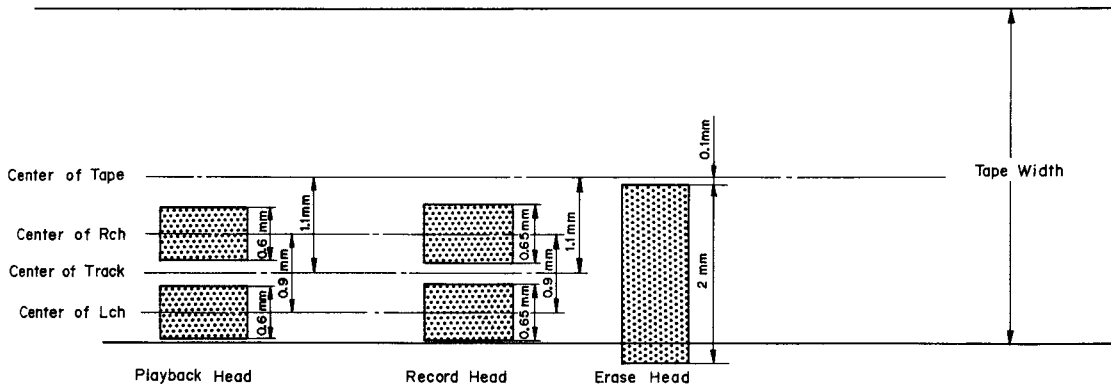

Fig. 2.1.7 Trackings

2.1.2. Double Capstan Tape Drive

As shown in Fig. 2.1.8, the double capstan system consists of two capstan shafts (a) and (b) connected to the two flywheels which are driven by a capstan belt.

Against these capstans two pressure rollers (a) and (b) are engaged to run the tape with an adequate holdback tension created by the double capstan and pressure rollers.

Since the diameter of capstan shaft (a) is smaller than that of capstan shaft (b), when two flywheels begin to turn as shown in the figure, capstan (a) runs slightly faster than capstan (b), which subsequently generates holdback tension.

As you note, if the diameters of the 2 capstans should be the same, the generation cycles of wow and flutter will become approximately the same, as a result of which defe-

ctive portion will be doubly superposed and preferable portion vice versa. The N-581 employs 2 capstans, each having different diameter and rotations, thereby avoiding the aforesaid occurrence and stabilizing wow and flutter characteristics.

As the double capstan system always creates a constant and stable holdback tension between the two capstans, the condition of the tape between two capstans will not be affected by any external conditions such as irregular take-up and supply torques, irregular loading of cassette tape, undesirable mechanism vibration and etc., thus assuring the superior wow and flutter characteristics. The double capstan system provides a constant holdback tension on the tape and maintains the stable pressure on the tape against the heads.

The only critical factor in the double capstan system is to be considered; the two capstans have to be positioned perfectly in parallel and to be precisely vertical against the head base, the pressure rollers have to be evenly pressed

against the capstan shafts and the head surface must be positioned perfectly vertical to the tape surface. Otherwise, the running tape might become out of the tape guide resulting in irregular movement.

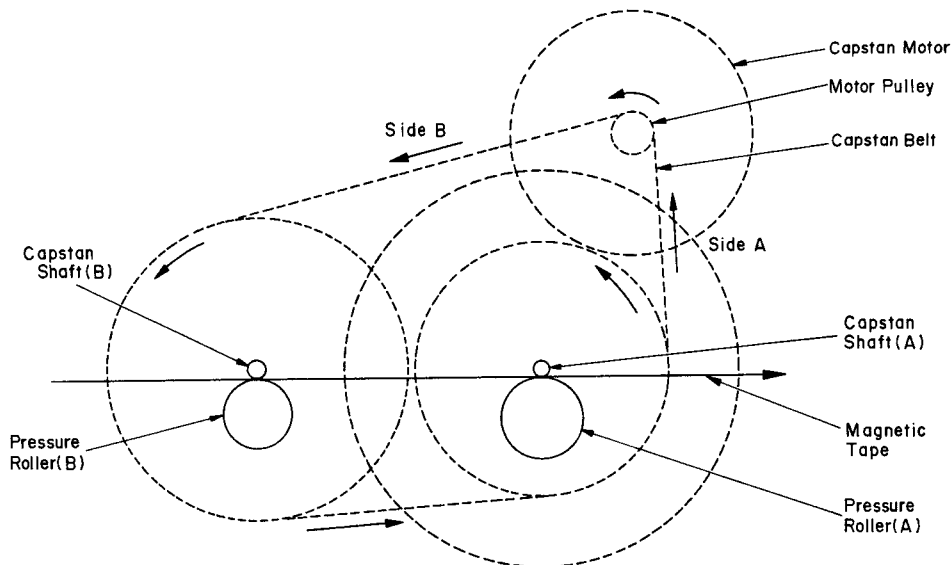

Fig. 2.1.8 Double Capstan Tape Drive

2.1.3. Mechanism Control Cam Operation

Refer to Fig. 2.1.9 Mechanism Control Cam timing chart. Function of N-581 Mechanism is done by Cam Control. Cam is driven by the Control Motor. The Motor operates so as to result zero in the difference of voltages between each voltage corresponding to mechanism function and each reference voltage which corresponds to each commands of the Control Switch. When the difference comes to zero, then it stops. In this way, each function is kept properly operated. For further details, please see the explanation on Logic Control. Here we explain principle of its mechanical functions.

Cam Control System works as follows: Cam Drive Gear is driven by Control Motor by means of Drive Belt. Cam Drive Gear is related to the cam with which each function may be mechanically set on.

(1) Play Mode

Press the Play Switch to make it Play mode. Then the Cam begins to move from Stop position to Play position and the Play mode will be set.

The Head Base which is linked to the Cam and which is normally pushed against the Stop position gets released and the Head Base will slowly come out for playing. To explain this function, first the Head Base is latched and the Reel Motor begins to turn. Then the Pressure Roller will be pushed and the Brake will be released. Now the tape begins to run. If you press the Pause Switch at this stage, it comes to Pause mode. Brake operates and the Pressure Roller moves away from the Capstan and the

Reel Motor stops.

Play mode may be changed to Stop mode by pressing the Stop Switch, and latch of the Head Base being released. The Cassette Case cannot be opened because of the latched eject effect unless it is in Stop mode.

(2) Record Mode

By pressing the Record Switch and the Pause or Play Switch, it may be made to Record mode. The Cam at this moment moves from Stop position to Rec. position. At the same time, Rec. Trigger Mechanism is driven and the Record Switch on the Main P.C.B. is switched on to the Record side. Further, the Cam turns until it comes to the Pause or Play position. On the other hand, the Rec. Trigger Mechanism is released during this process. When the Cam is set in Rec./Pause or Rec./Play position, Record signals will be sent to Bias Oscillating Circuit from Logic Control Circuit to let the Bias to oscillate.

Press the Stop Switch and the Cam comes back to the Stop position. At the same time, it will set the Record Switch on the Main P.C.B. to the Play side.

(3) F.F. or Rewind Mode

By pressing F.F. or Rewind Switch, it comes either to F.F. or Rewind mode. The only difference of these two modes is that one is to turn the Reel Motor reverse and the other to transmit the torque against the Reel Hub onto the take-up side or to the supply side. Brake is released at this stage and the Reel Motor begins to turn F.F. or Rewind.



(4) Pause Mode

Press the Pause Switch to make it to Pause mode. In changing it from Stop mode to Pause mode, the Brake is first released, then the Head Base is latched, and again the Brake works.

At this stage, the Reel Motor would not turn with the Pressure Roller being apart from the Capstan, and the tape would remain still.

(5) Cue Mode

Cue mode may be either of Forward Cue or of Reverse

Cue mode.

In either case, it could be effected by pressing F.F. Switch or Rewind Switch after the Pause Switch has been pressed. The speed of the tape at this moment will be 1/3 the running speed of normal F.F. or normal Rewind. The tape speed will get slow further down to 1/5 the speed of F.F. or of Rewind if you keep on pressing the F.F. or Rewind Switch. In this case, the Brake is released at first and then the Head Base will get latched at the Cue position and the Reel Motor will start while the Pressure Roller remains apart from the Capstan.

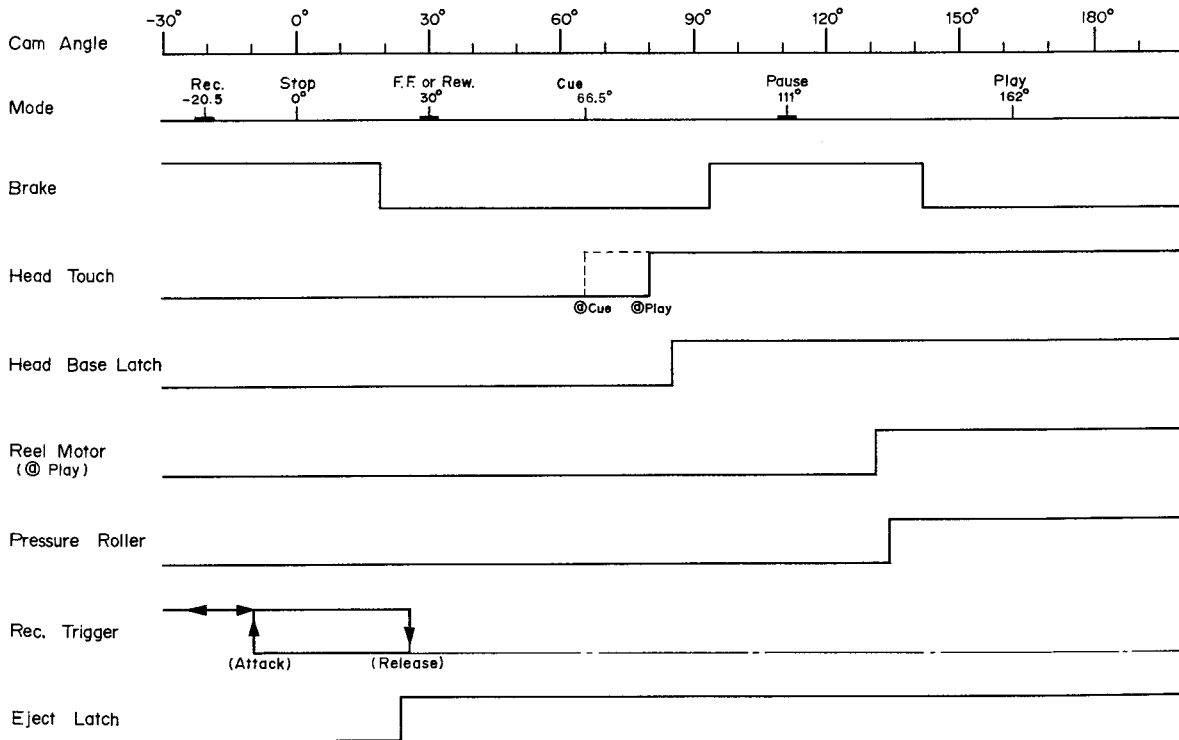

Fig. 2.1.9 Mechanism Control Cam Timing Chart

2.2. Amp. Circuits

2.2.1. Playback Eq. Amp. Circuit

Fig. 2.2.1 shows playback equalizer amp. circuit.

Fig. 2.2.2 shows its system diagram, and Fig. 2.2.3 shows time constant of equalizer.

Playback Head is connected to the input of this circuit. Amplifier, which is composed of Q105, 106 and 107, is an equalizer amplifier and its time constant is shown in Fig. 2.2.3. R146, R147, L105 and C139, which consist of peaking circuit, compensate Playback Head gap loss and improve frequency response at high. L105 and C138 compose bias trap circuit and prevent bias leakage from playback eq. amp. circuit. L105 is of variable type and adjustment performed by L105 is mainly for the purpose of reducing bias leakage.

Playback eq. amp. gain adjustment should be performed so as to obtain 100 mV at TP101 (TP201) by adjusting

VR102 (VR202) during the course of playing back 400 Hz Level Tape (DA09005A). Eq. Switch (70 μs/120 μs) is connected to playback eq. amp. circuit and the overall time constant of playback eq. amp. circuit will become as follows:

$$\text{Eq. Switch} - 70 \mu\text{s} : 3180 \mu\text{s} (50 \text{ Hz}) + 70 \mu\text{s} (2274 \text{ Hz})$$

$$\text{Eq. Switch} - 120 \mu\text{s} : 3180 \mu\text{s} (50 \text{ Hz}) + 120 \mu\text{s} (1326 \text{ Hz})$$

Following table shows tapes used at each Tape Switch combined with Eq. Switch.

Tape SW	Eq. SW	Tape
ZX	70 μ s	Nakamichi ZX
SX	70 μ s	Nakamichi SX, TDK SA, Maxell XL-II Scotch Master 70 μ s
EX	120 μ s	Low-Noise High-Density (including EX, EXII, TDK AD, Maxell XL-I, Scotch Master 120 μ s)
	70 μ s	Nakamichi EX, EXII

It is specified in IEC Standard that time constant is 120 μ s on tapes of ferric oxide, and 70 μ s on tapes of CrO2.

However, in the case of Eq. Switch on N-581, when time constant at playback is changed, at the same time time constant at record must also be changed. Therefore, even though record and playback is made by the method other than the IEC Standard, no deterioration of frequency response or level difference will occur. (Any other method for instance, record and playback on ferric oxide tape with putting Tape Switch on EX and Eq. Switch on at 70 μ s.) When Nakamichi EX or EXII Tape is used at Tape Switch: EX, and Eq. Switch: 70 μ s, S/N ratio will be improved by approximately 4 dB (WTD).

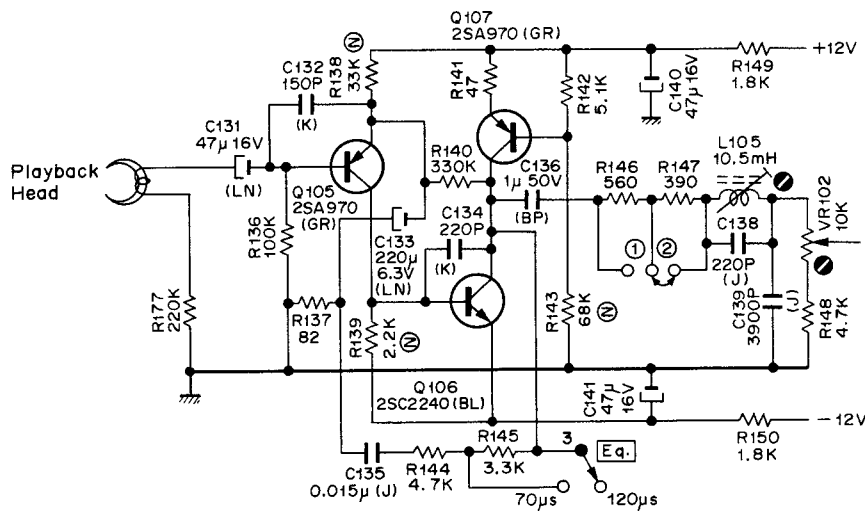

Fig. 2.2.1 Playback Eq. Amp. Circuit

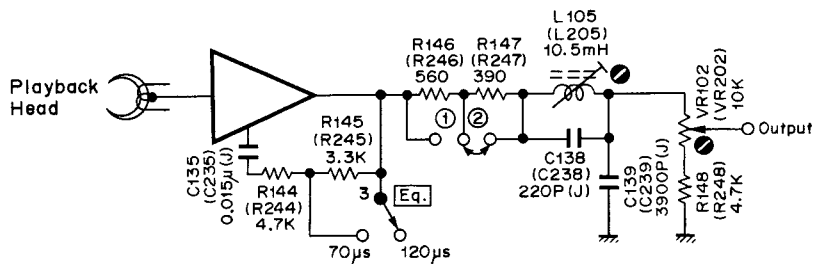

Fig. 2.2.2 System Diagram

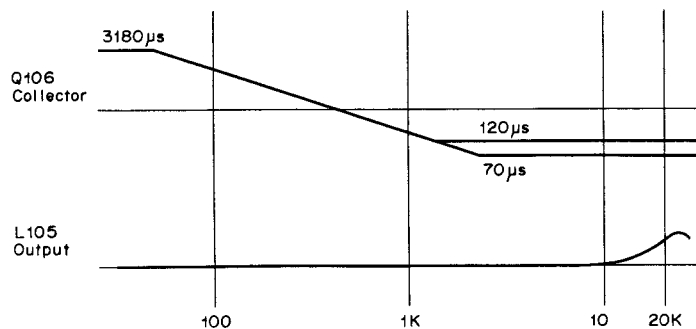

Fig. 2.2.3 Time Constant

2.2.2. Record Amplifier Circuit

Fig. 2.2.4 shows record amplifier circuit which employs a low noise operational amplifier IC.

This circuit adopted the direct coupling system (the DC amp. output is connected directly with the Record Head). Direct coupling system provides improvements of linearity and phase characteristic at low frequency, less distortion (as a clipping level becomes higher), etc.

This record amp. is muted with record signal from Logic P.C.B. Ass'y and also with mute signal.

With the exception of record mode, input and output of record amp. is muted simultaneously. At record mode, when mute signal is given from Logic P.C.B. Ass'y, input of record amp. will be muted.

2.2.3. Bias Oscillation Circuit

Fig. 2.2.5 shows a push-pull oscillator with an oscillation frequency of 105 kHz which is constructed by capacitors C316 and C317, coupling the collectors and bases of two transistors (Q301 and Q302).

This is used to provide recording bias and as an erase signal.

By pressing the Record and Pause, or Record and Play Buttons, Rec. signal conducted from the Logic P.C.B. Ass'y becomes L, and Q303 turns to ON.

Therefore, +12 V is applied to the circuit through Q303, as a result of which oscillation begins.

When the record mode is released, oscillator output is damped by the discharge of C315. This prevents magnetization of the Record Head.

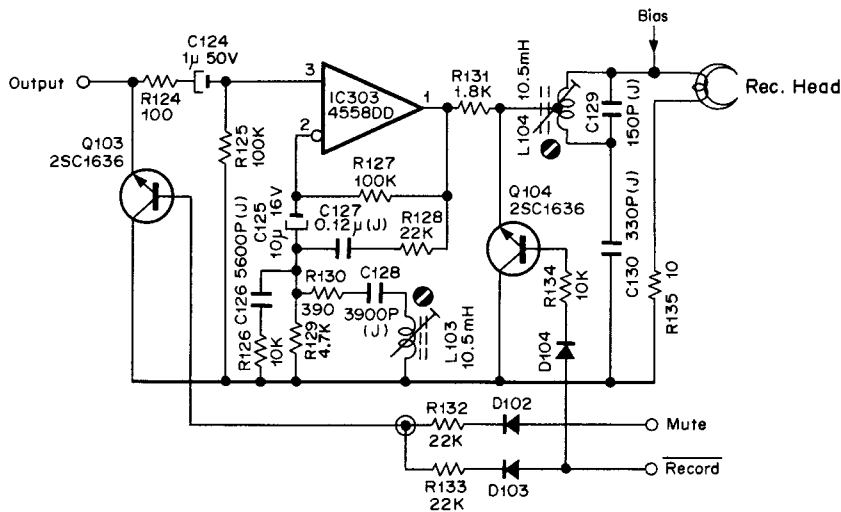

Fig. 2.2.4 Record Amp. Circuit

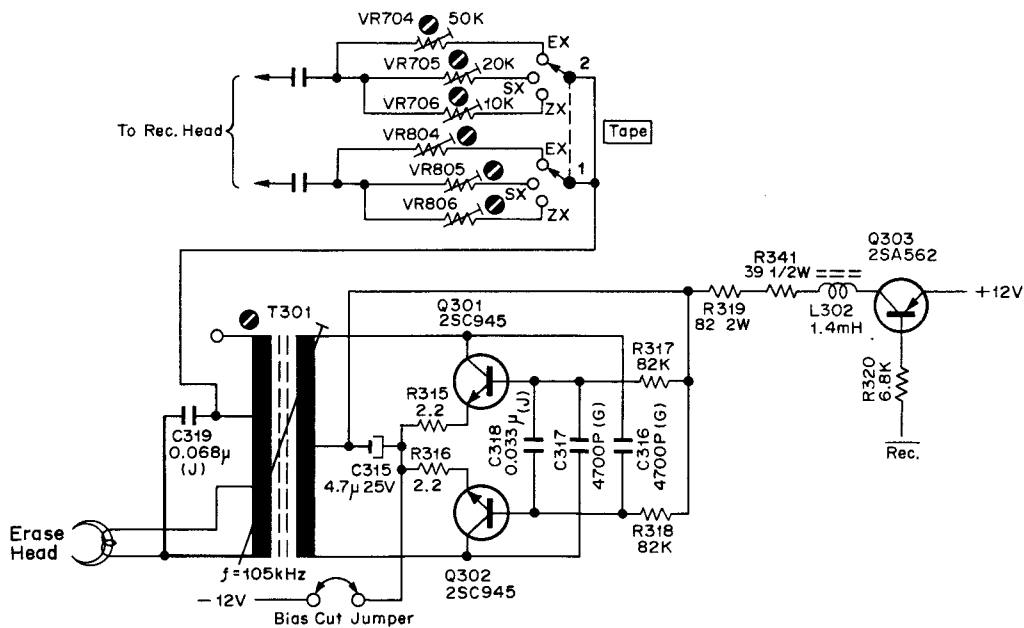

Fig. 2.2.5 Bias Osc. Circuit



2.2.4. Test Tone Circuit

Figs. 2.2.6-A and 2.2.6-B show the test tone circuit. By means of the operational amplifier IC, the N-581 oscillates 2 kinds of tones, which are 400 Hz (0 dB) for record level calibration and 15 kHz (-20 dB) for bias calibration. Meter amp. gain will be increased by 20 dB at 15 kHz, because R178 is added in parallel with R151. As shown in the figure, the test tone consists of oscillation portion through IC RC 4558D and band pass filter comprising either of 400 Hz or 15 kHz can be selected by the Test Tone Switch.

Power will be supplied to the test tone circuit when Power Switch is set to ON. IC301-1/2 consists of oscillation circuit, feeds its output back to input and oscillated square wave up to power source voltage level so

that the oscillation voltage can be stabilized. A capacitor is connected to No. 6 terminal of the IC301-1/2 for convenience while changing over one frequency to another (400 Hz: 0.0114 μ F, 15 kHz: 200 pF).

Band pass filter is created between IC301-1/2 and 2/2, and the sine wave of the selected frequency will be obtained at the output terminal 1 of the IC301-2/2. With regard to band pass filter curve, refer to Fig. 2.2.7.

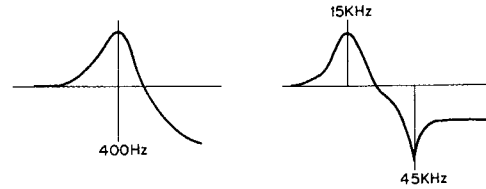

Fig. 2.2.7 Band Pass Filter Curve

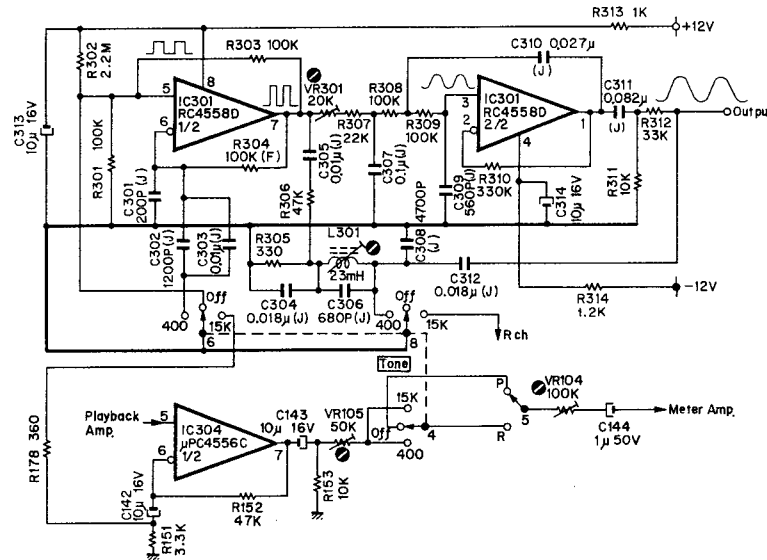

Fig. 2.2.6-A Test Tone Circuit

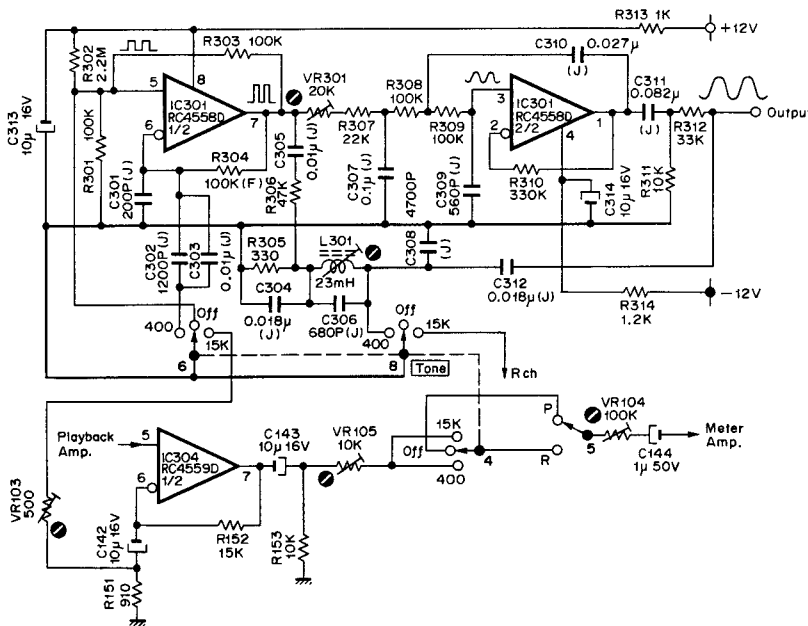

Fig. 2.2.6-B Previous Type

2.3. Mechanism Control Circuits

2.3.1. Logic Control

Refer to Fig. 12.2 block diagram for mechanism control circuits.

(1) C-MOS IC

(a) Features of C-MOS IC

The IC's used in the logic circuit of the N-581 are of the C-MOS (complementary metal oxide semiconductor) type, in which P-channel and N-channel MOS FET's complement each other.

1) Small power consumption

A C-MOS is an inverter, as shown in Fig. 2.3.1.

Whether the input of this inverter is at "H" or "L" level, either the P-channel or N-channel MOS FET is OFF, and therefore, current does not pass from VDD to VSS under steady normal state. Consequently, when there is no input, power consumption ($V_{DD} \times I_{DD}$) is nearly zero, except for surface and junction leakage.

When the input signal is switched from "H" to "L", or "L" to "H", however, both P- and N-channel FET's instantly come on, and a current flows either charging or discharging the stray output capacity, so that the power consumption during dynamic operation cannot be said to be zero.

2) A large noise margin

The input-output transmission characteristics of the C-MOS inverter differ from those of bipolar IC's as shown in Fig. 2.3.2. The knee characteristic is sharper, the threshold voltage is almost half of VDD, and the output amplitude is nearly equal to $V_{DD} - V_{SS}$.

Since the noise margin of a digital IC is defined as the difference between the minimum value of output amplitude and the minimum required amplitude of the input signal, it is quite natural that the C-MOS circuit, which produces an output amplitude of nearly $V_{DD} - V_{SS}$ and is operated by a small input signal, should have a large noise margin.

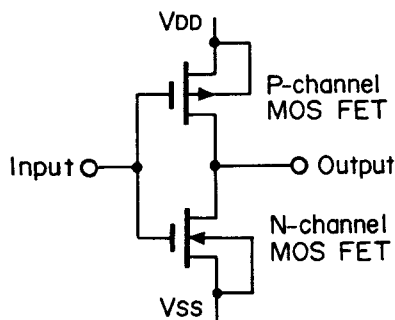

Fig. 2.3.1

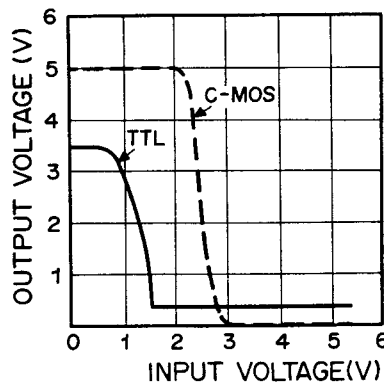

Fig. 2.3.2

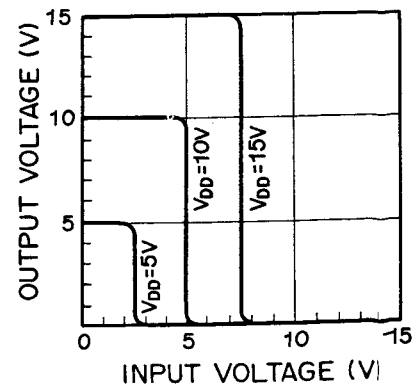

Fig. 2.3.3 Input-Output Transfer Characteristics of C-MOS

3) High input impedance

A C-MOS IC has a very high input impedance because it is insulated from the substrate by the oxide film of the gate. Although leakage resistance must be considered in an actual C-MOS IC because diodes are usually used in the direction of reverse bias for protecting input circuit, its impedance is several tens of megohms. The advantage of a high input impedance is that the fan-out of the IC is large, which simplifies the interface. Also, a timer circuit for a longer period of time can be produced. This means that the high input impedance enables the input to be connected with a large resistance, but does not mean to use a capacitor of large capacity.

4) Wide operating voltage range

Fig. 2.3.3 shows input-output transfer characteristics of C-MOS. The general purpose C-MOS family has a wide operating voltage range extending from 3 to 18 V, which is much wider than that of TTL and DTL (5 ± 0.25 V), and HTL (15 ± 1.5 V). The reason for the C-MOS IC's wide operating voltage range is that the P-MOS and N-MOS are made symmetrical, and if VDD is varied, the threshold voltage for the circuit is always about half of VDD. In a bipolar IC, the threshold voltage is decided by the forward voltage from the base to the emitter of the transistor (V_{BE}), and is little affected by the source voltage. Therefore, if the source voltage exceeds a certain limit, the output voltage and the threshold voltage will not balance, as a result of which operation will become impossible.

With a C-MOS, the threshold voltage varies according to changes in the source voltage, and stable operation throughout a wide range can be expected. As indicated above, the performance of a C-MOS IC as a digital IC is excellent.

(b) Gate Logic

2-input NOR and NAND gates are used.

Following shows each logic symbol, truth table, pin assignment, and internal schematic diagram.

1) NOR Gate

The output will be H only if inputs IN1 and IN2 are L's, and the output will be L if IN1 is H or IN2 is H.

(H: +12 V, L: 0 V)

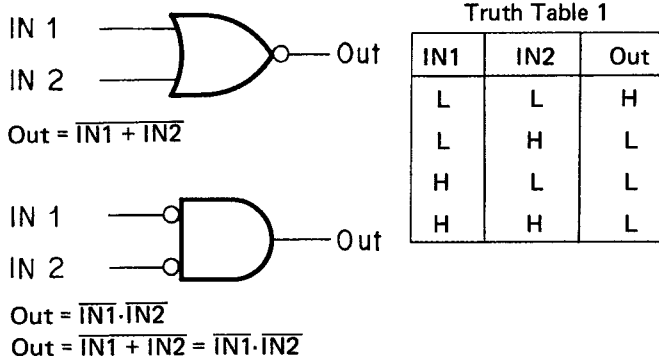

Fig. 2.3.4

The construction of the foregoing 2 Logic Symbols is identical and intended to show the use of either OR or AND.

2) NAND Gate

The output will be L only if inputs IN1 and IN2 are H's, and the output will be H if IN1 is L or IN2 is L.

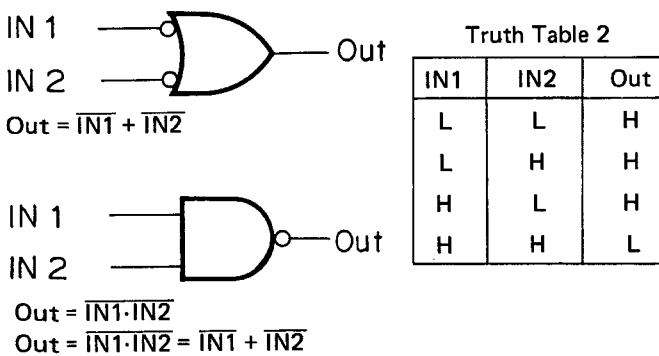

Fig. 2.3.7

The construction of the foregoing 2 Logic Symbols is identical and intended to show the use of either AND or OR.

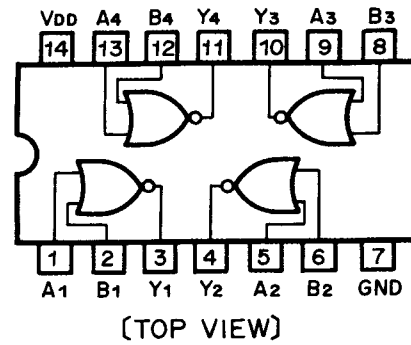

Fig. 2.3.5

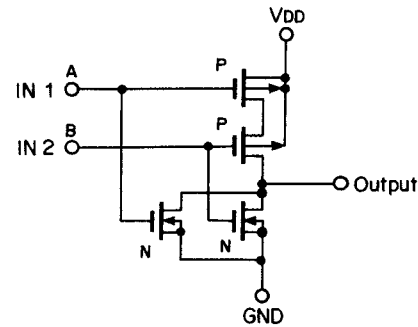

Fig. 2.3.6

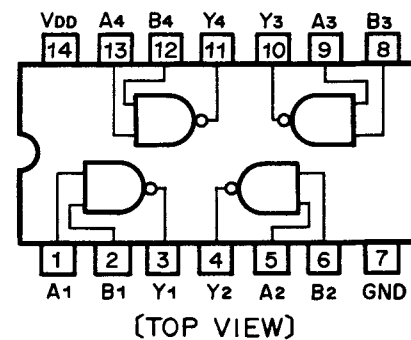

Fig. 2.3.8

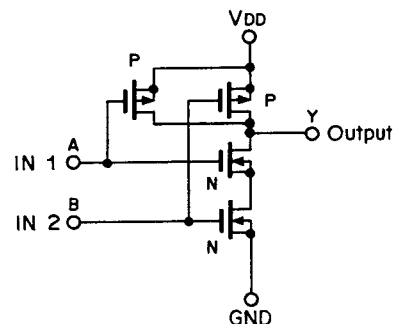

Fig. 2.3.9

(c) Gated Flip-Flop

The two NAND gates can be used to form flip-flop. The inputs operate as follows:

When both S and R are H's, the flip-flop will remain in its present state, i.e., will not change the state.

If however, the R input goes to L, the NAND gate connected to R will have H output regardless of the other feedback input to the NAND gate, and this will force the flip-flop to the L state (provided the S input is kept H). Similar reasoning shows that making the S input an L will cause the NAND gate at the S input to have an H output, forcing the flip-flop to the H state (again provided the R input is kept H).

If both inputs R and S are made L's, the next state will depend on which input is returned to H first, and if both are returned to H simultaneously, the resulting state of the flip-flop will be indeterminate. As a result, this is a "forbidden" or "restricted" input combination.

In the actual use, the activation speed of the flip-flop is managed to be delayed in order to prevent erroneous movements caused by noise as shown in Fig. 2.3.11.

Truth Table 3

Set	Reset	Q	\bar{Q}	Remarks
L	L	H	H	*: Maintains the previous state.
L	H	H	L	
H	L	L	H	
H	H	*	*	

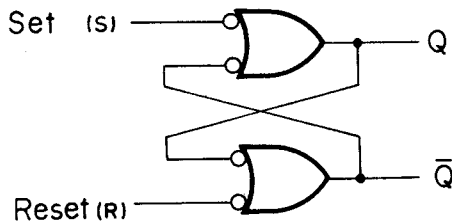

Fig. 2.3.10

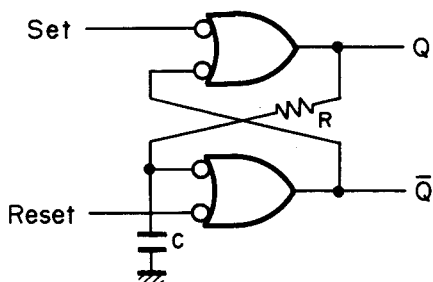

Fig. 2.3.11

(d) Compatible C-MOS ICs

IC401, 402, 403 : μ PD4011C, CD4011A, MC14011A, F34011A, TP4011A, TC4011P

IC404 : μ PD4001C, CD4001A, MC14001A, F34001A, TP4001A, TC4001P

(2) Logic Control and Other Circuits

A foolproof operation will be done by logic control. For example, when command the playback mode while fast winding or command fast-forward mode while rewinding, it is guaranteed that no abnormal tape tension will happen by passing through the stop mode. This is also guaranteed even when the switches are pressed simultaneously.

(a) Logic Signal

How to read signals is referred to the following:

Positive logic is used; the signal H shows the condition that the signal is executing, and in case there is a - on the signal, signal L shows the condition that the signal is executing.

1) \overline{Kstop} (Stop switch output signal)

\overline{Kstop} becomes L when the Stop switch is pressed, and \overline{Kstop} is H while switch is open.

In other words, $\overline{Kstop} = L$ shows while Stop mode is commanded, and $\overline{Kstop} = H$ shows stop is not commanded.

2) \overline{PLAY} (Play Flip-Flop \bar{Q} output signal)

$\overline{PLAY} = H$: out of Play mode

$\overline{PLAY} = L$: in Play mode

3) PLAY (Play Flip-Flop Q output signal)

PLAY = H: in Play mode

PLAY = L: out of Play mode

(b) Logic Operating Status

Refer to Fig. 2.3.12 (Logic Status).

Each stage of logic status under the series control switch operation is shown in the figure.

(c) Conditions of Flip-Flops

1) FF Flip-Flop

$$\text{Set} = \overline{Kff}$$

$$\text{Reset} = \overline{Kplay} + \overline{Krew} + \overline{Kstop}$$

2) REW Flip-Flop

$$\text{Set} = \overline{Krew}$$

$$\text{Reset} = \overline{Kplay} + \overline{Kff} + \overline{Kstop} + \overline{\text{Memory Rewind}}$$

($\overline{\text{Memory Rewind}} = L$: With Memory switch ON, a differential L pulse generates when the tape counter reaches "999".)

3) PLAY Flip-Flop

$$\text{Set} = \overline{Kplay}$$

$$\text{Reset} = \overline{Kff} + \overline{Krew} + \overline{Kstop} + \overline{\text{PAUSE}}$$



4) PAUSE Flip-Flop

Set = K_{pause}

Reset = $K_{\text{play}} + K_{\text{stop}} +$ (the rising of the FAST signal)

(FAST = FF + REW. When FAST signal becomes H, a differential pulse is generated at the rising of the signal. This pulse conducts Q404 to turn ON, accordingly PAUSE Flip-Flop is reset.)

5) REC Flip-Flop

Set = $K_{\text{rec}} \cdot \overline{\text{FAST}} \cdot \overline{\text{PAUSE}} \cdot \overline{\text{PLAY}} \cdot \overline{\text{Record Protector Switch OFF}}$

= $K_{\text{rec}} \cdot \overline{\text{FAST}} \cdot \text{Q405 OFF}$

(Q405 OFF = $\overline{\text{PAUSE}} \cdot \overline{\text{PLAY}} \cdot \overline{\text{Record Protector Switch OFF}}$)

Reset = $\overline{\text{PLAY}} \cdot \overline{\text{PAUSE}} = \text{Q406 ON}$

MODE	STOP	RECORD				PLAY-BACK	FAST WIND		CUE	
		RECORD	RECORD PAUSE	PLAY	PAUSE		FF	REW	PAUSE	
	L	L	L	H	L	H	L	L	L	
	H	H	H	L	H	L	H	H	H	
	L	H	H	H	H	L	L	L	L	
	H	H	L	L	L	H	H	H	H	
	L	L	H	L	H	L	L	L	H	
	H	H	L	H	L	H	H	H	L	
	L	L	L	L	L	L	H	L	L	
	H	H	H	H	H	H	L	H	H	
	L	L	L	L	L	L	L	H	H	
	H	H	H	H	H	H	H	L	L	
REC (Q421 Collector)	H	H	L	L	L	H	H	H	H	
MUTE (Q424 Collector)	H	H	L	L	L	L	H	H	L	
CUE (Q426 Collector)	H	H	H	H	H	H	H	H	L	

Fig. 2.3.12 Logic Status



(d) Initial Reset and Power Mute

Refer to Fig. 2.3.13 circuit diagram and Fig. 2.3.14 timing chart.

When the power switch is turned ON, the voltage of the power source increases from 0 to +12 V DC. After this voltage is built up, Q403 is turned ON and the mute signal is generated, until C402 is charged through R404, R405, and R406. At the same time, this signal enters the base of Q417 in the automatic shut-off circuit, and turns this transistor ON so that it generates $\overline{Kstop} = L$ pulse.

When the power switch is turned OFF, the signal from the secondary winding of the transformer entering Q401 soon ceases and Q401 is in the cutoff state. Since the base of Q402 is positively charged, Q402 comes ON, which turns Q403 ON and produces the $\overline{Kstop} = L$ pulse. The $\overline{Kstop} = L$ pulse resets each flip-flop to its initial condition (the stop condition).

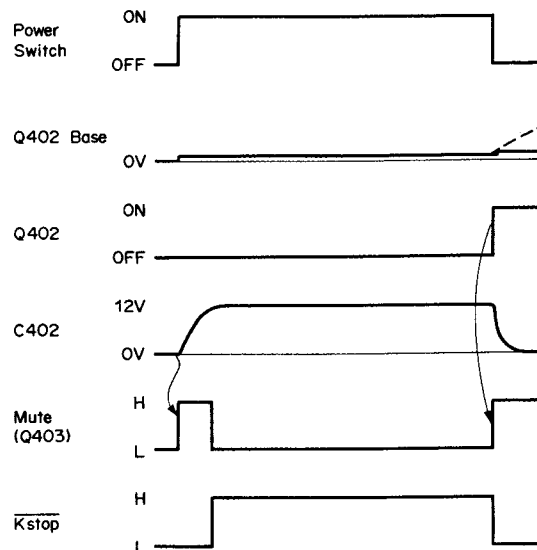

Fig. 2.3.14 Timing Chart

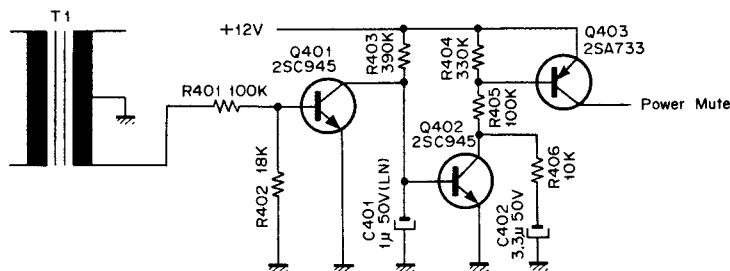

Fig. 2.3.13 Initial Reset and Power Mute Circuit

(e) One-shot Pulse-generating Circuit

Refer to Fig. 2.3.15 circuit diagram and Fig. 2.3.16 timing chart.

The circuit consists of IC403-4,5, and 6, IC403-1, 2, and 3, Q407, R420, R421, C412, etc. When the mode is changed as shown below, the circuit generates a one-shot pulse of approximately 400 msec, so that this period passes in the stop mode, and as soon as this is over, a new mode is set:

- From FAST (FF or REW) mode to PLAY or PAUSE mode;
- From PLAY mode to FAST (FF or REW) mode;
- From FF mode to REW mode, or vice versa.

This interval is necessary to avoid an extraneously large tension on the tape, in view of the response of the tape deck mechanism.

1) From PLAY mode to FF mode

Since the PLAY flip-flop is set during playing, IC403-6 is H and IC403-5 is L, and therefore, IC403-4 is H and C412 is charged to +12 V. Consequently, IC403-3 is L, and the gates connected to IC403-3 are open.

When the FF switch is pressed the PLAY flip-flop is reset, and at the same time, the FF flip-flop is set. However, the capacitor C413 connected to the PLAY flip-flop retards

so that PLAY = L. Therefore, FF = H and PLAY = H for a short period, and a narrow pulse is produced in IC403-4. C412 is discharged by this L pulse, but it is charged again through R420 and R421 when the L pulse is released. IC403-3 is maintained at H for approximately 400 msec, until the voltage of C412 exceeds the threshold of IC403-1 and 2, and the gates connected to IC403-3 are closed to bring about the stop condition.

2) From FF mode to REW mode

When the REW switch is pressed, the FF flip-flop is reset, and the REW flip-flop is set. As in case 1), a narrow H pulse is generated in the base of Q407, cutting off Q407, and as a result, C412 is discharged through D411. The subsequent actions are the same as in 1).

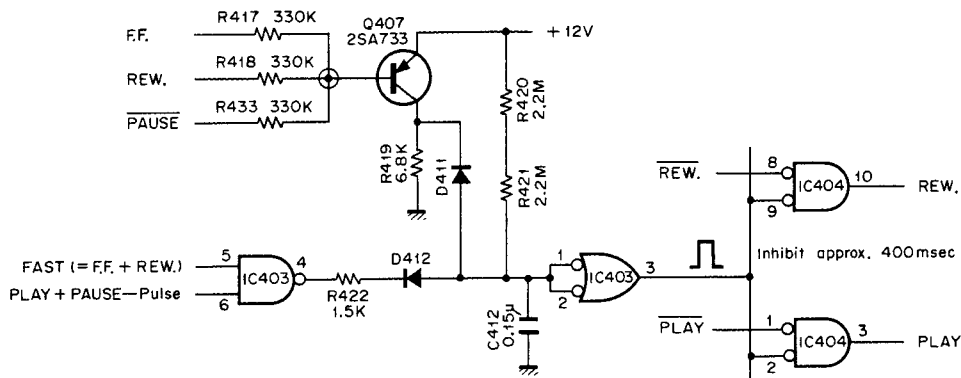

Fig. 2.3.15 One-shot Pulse-generating Circuit

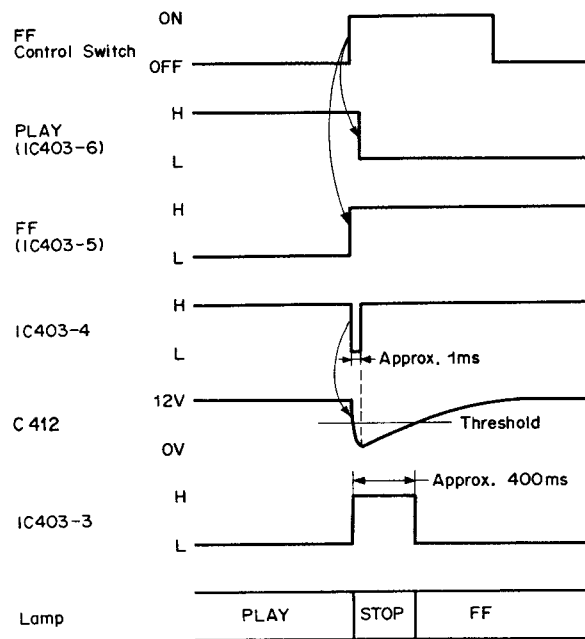

Fig. 2.3.16 Timing Chart

(f) Unattended RECORD/PLAY

Unattended recording or playback can be carried out by the use of the Tape Start Memory/Timer Switch. When the power is connected a differential pulse is supplied to Q415 through C420, and Q415 is turned ON. Therefore, when the Tape Start Memory/Timer Switch is moved to

REC side, D424 and D425 are grounded through Q415, and the RECORD mode is selected. When it is moved to the PLAY side, only D425 is grounded, and the PLAY-BACK mode is selected.

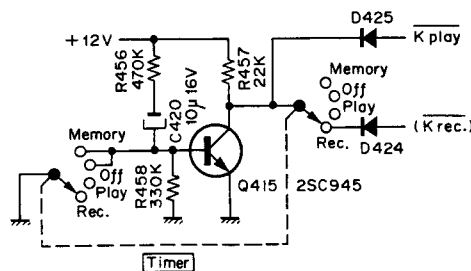

Fig. 2.3.17 Unattended Record/Play Circuit

(g) \overline{REC} Signal

Refer to Fig. 2.3.18. This is the signal that controls bias oscillation in the amplifier circuit. In RECORD/PLAY and RECORD/PAUSE modes, $\overline{REC} = L$, and bias oscillation is started. Q421 is turned ON when the REC flip-flip is H and Q422 is OFF, i.e., when the cam selects PLAY or PAUSE mode mechanically, and $\overline{REC} = L$.

(h) \overline{CUE} Signal

Refer to Fig. 2.3.18. When the PAUSE switch is pressed during the FAST (FF or REW) mode, $\overline{CUE} = L$, and the output level of the amplifier circuit is attenuated. Q426 is turned ON at FAST/PAUSE, thus $\overline{CUE} = L$.

(i) Mute Signal

Refer to Fig. 2.3.18. When Q424 is ON and when the Mute-power is H through D434, MUTE = H and the amplifier circuit is muted.

$$Q424 \text{ ON} = Q423 \text{ OFF } (= \overline{CUE} \cdot \overline{REC}) \cdot (\text{STOP} + \text{PAUSE} + Q425 \text{ ON (PLAY-Position)})$$

The modes in which the amplifier circuit is not muted are (MUTE = L):

$$Q424 \text{ OFF} = \overline{Q424 \text{ ON}} = \overline{CUE + REC + \text{STOP} \cdot \text{PAUSE} \cdot \text{PLAY-Position}}$$

i.e., the FAST/PAUSE (i.e., CUE) mode, RECORD or RECORD/PAUSE mode, and PLAY mode.

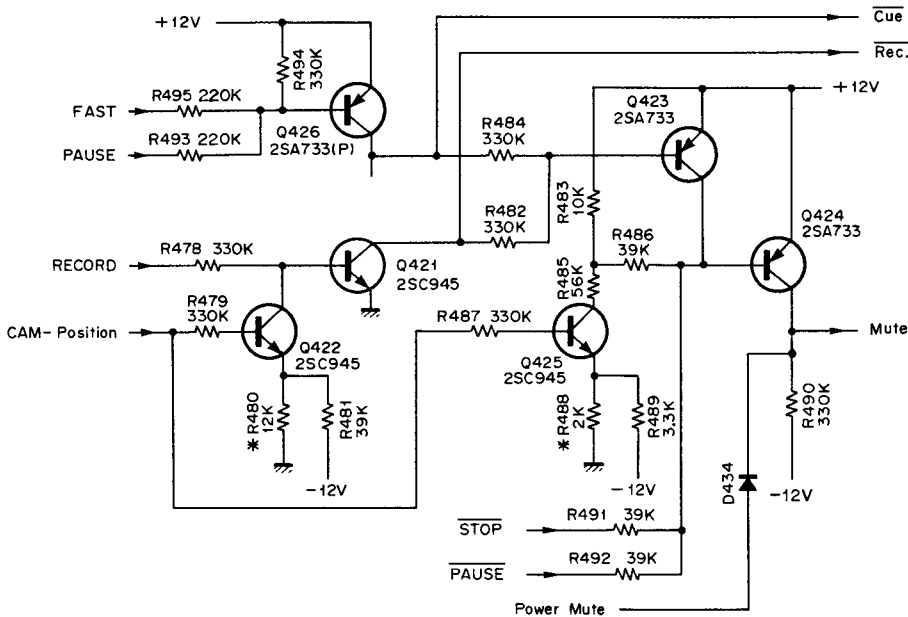

Fig. 2.3.18

(j) Take-up Function at Loading

Refer to Fig. 2.3.19. SW503 Eject Switch is closed when eject is made. When a cassette tape is inserted into the Cassette Case Ass'y and loaded, SW503 will become open. Therefore, plus voltage is applied at No. 2 pin of IC405 until C428 (4.7μF 25V) is charged up through R542 (2.2 MΩ).

Accordingly Reel Motor rotates forwardly and eliminates tape loosening of the cassette tape if any.

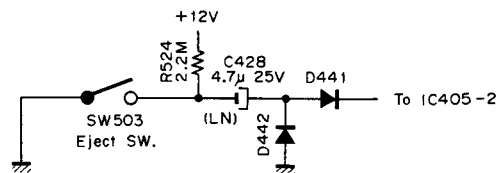

Fig. 2.3.19

2.3.2. Shut-off Sensor and Detector

Refer to Fig. 2.3.20 circuit diagram and Fig. 2.3.21 timing chart.

(1) Shut-off sensor

Light from lamp PL501 is projected through holes in a disc rotating synchronously with the take-up reel, and the intermittent flashes coming through the disc are converted into electrical signals by a phototransistor (Q602). These signals are amplified into square waves, and transmitted to the shut-off detector in the subsequent stage. When the tape-end comes, the take-up reel and the disc stop rotating, and no pulse is output from the sensor.

(2) Shut-off detector

The shut-off detector, which receives the pulse output from the sensor, produces the shut-off signal (i.e., $\overline{Kstop} = L$) having detected a certain period of absence of pulse, and this signal resets each flip-flop in the logic control circuit.

- (a) Through C421, Q416 is ON and discharges C422 at every H cycle of the sensor output pulse. On the other hand, C422 ($1 \mu F$) is charged through R461 ($2.2 M\Omega$) in the PLAY (Playback or Record) mode or the FAST (FF or REW) mode.
- (b) At the end of the tape, no sensor output is produced and Q416 is not turned ON, resulting in C422 being charged continuously. When the voltage of C422 exceeds the sum of the emitter voltage (approx. 1.1 V) and the VBE of Q417, Q417 is turned ON and transmits the shut-off signal ($\overline{Kstop} = L$) to the logic control circuit.

- (c) In the STOP mode, C422 is grounded through D426 and R459, and the shut-off detection function is made inoperative. When PAUSE switch is pressed, C422 is discharged through D437.
- (d) Q417 is turned ON by the mute-power signal generated whenever power is turned ON or OFF, and produces the $\overline{Kstop} = L$ pulse.

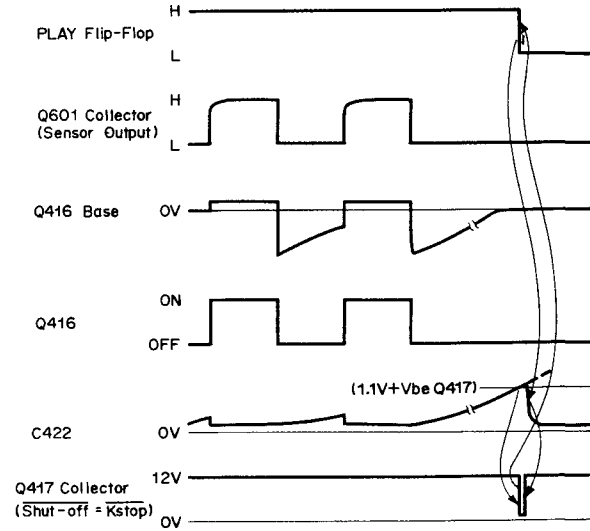

Fig. 2.3.21 Timing Chart

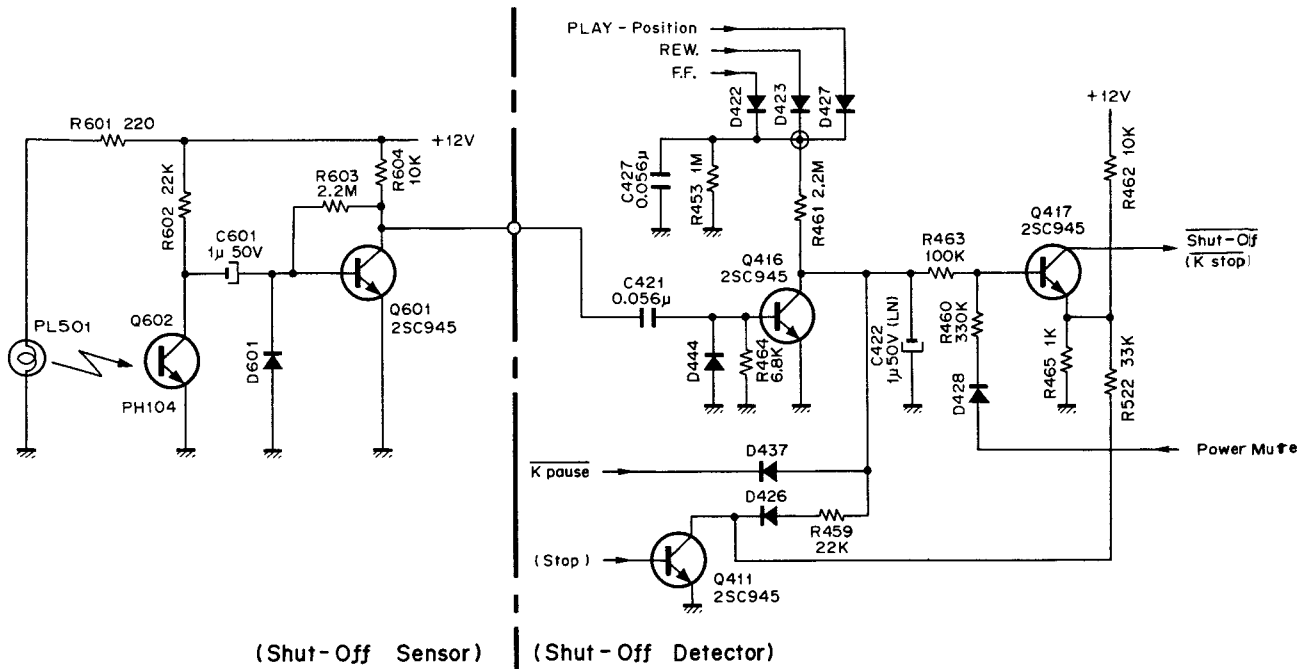

Fig. 2.3.20 Shut-Off Sensor and Detector Circuit

2.3.3. Control Motor Drive Circuit

Refer to Fig. 2.3.22 circuit diagram and Fig. 2.3.23 timing chart for the series control switch operation. The control motor is turned by varying amounts, according to which control switch is set. This motor is connected to the mechanism control cam, and the mechanism of the N-581 is set to the mode indicated by this cam. The motor is driven by the differential amplifier (IC405) and drivers Q431 and Q432. When the motor has stopped, the voltage at the sliding contact of the cam control variable resistor moving synchronously with the motor (control voltage) is balanced with the reference voltage corresponding to each mode, and the input difference of the differential amplifier is zero. When a new mode is demanded, a different reference voltage breaks the balance at the differential amplifier, and the motor operates.

The motor drives the cam control variable resistor and changes the control voltage. When the control voltage is changed and the input difference of the differential amplifier becomes zero, the motor stops.

The following table shows the position of the cam and the voltage at the sliding contact of the cam control variable resistor:

Position on Cam	Voltage at Sliding Contact of Cam Control Volume
Stop	3.0 V
Rec	4.1 V
FF/REW	1.3 V
Pause	-2.8 V
Play	-5.4 V
Cue	-0.4 V

State of transistors in each mode:

- STOP: Q427, Q428, Q429, Q430 OFF
- PLAY: Q429 ON
- FF/REW: Q428, Q430 ON
- REC: Q427, Q430 ON (in the form of pulse)
- PAUSE: Q429 ON
- CUE: Q428, Q429, Q430 ON

RECORD mode

When RECORD switch and PLAY switch are pressed, Q427 pulses ON and OFF through C426, and the cam moves to the RECORD position. Then cam moves to the PLAY position and stays there, thus the mechanism is set to the RECORD mode.

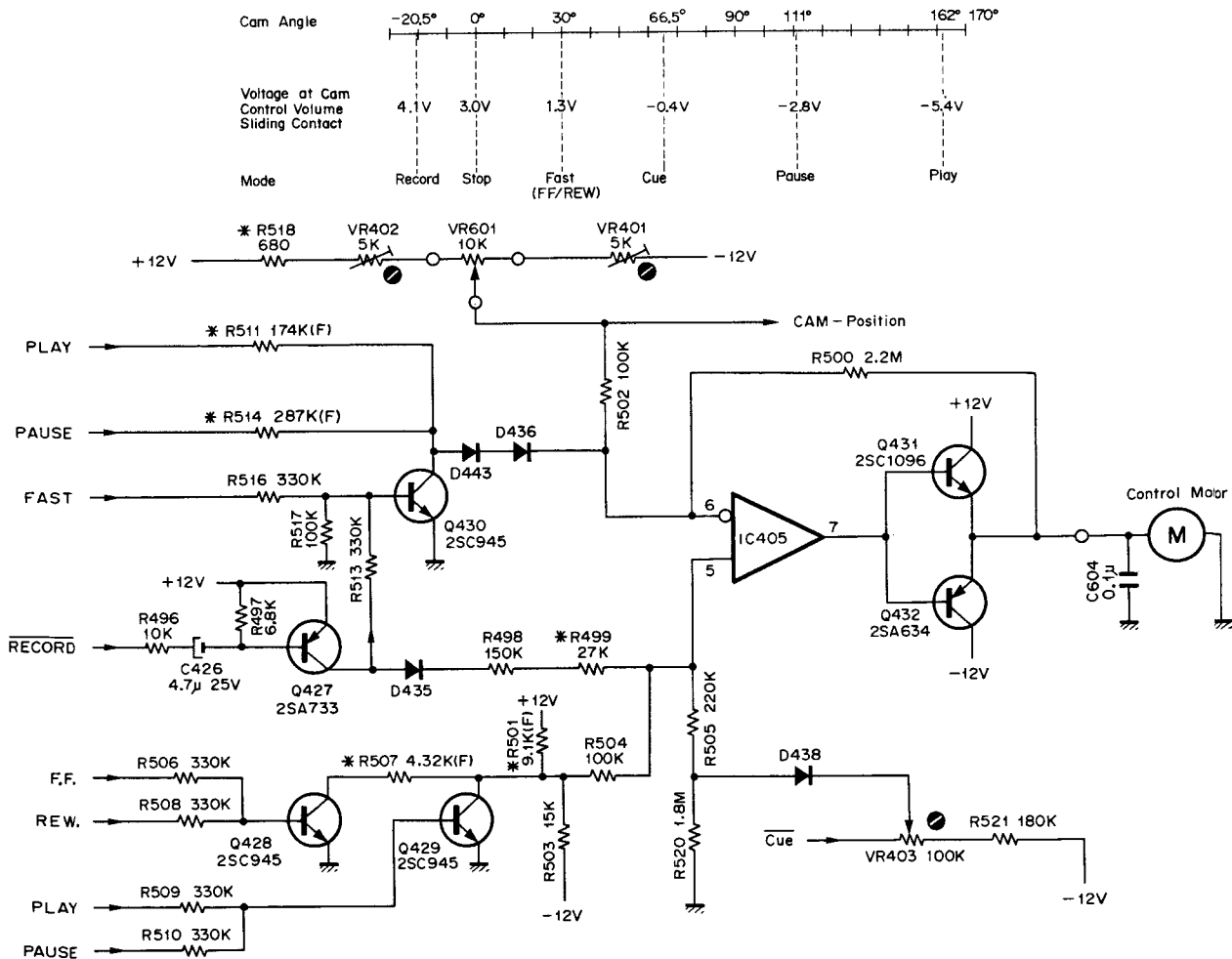

Fig. 2.3.22 Control Motor Drive Circuit

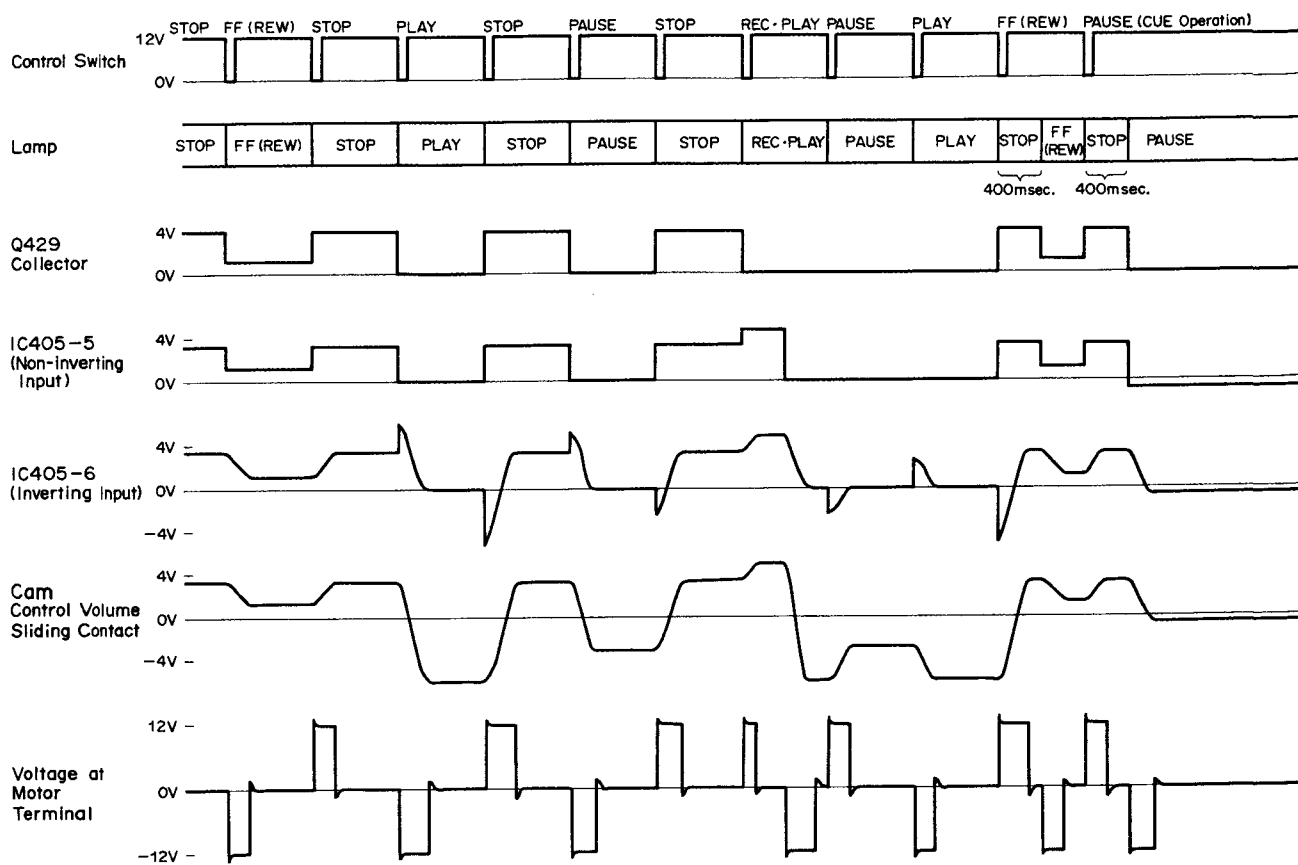

Fig. 2.3.23 Timing Chart

2.3.4. Capstan Motor Governor

This is a governor employing a PLL (phase-locked loop) IC, and drives the capstan motor at a constant speed when the power switch is turned ON.

2.3.5. Reel Motor Governor

Refer to Fig. 2.3.24 circuit diagram and Fig. 2.3.25 timing chart.

This is a governor controlling the reel motor speed and it consists of a differential amplifier, IC405, and motor drivers, Q419 and Q420, etc. The speed of the motor varies as follows:

(1) PLAY

Q418 is ON and IC405-2 (inverting input) is supplied with a positive voltage, and Q420 is conducted. The motor is kept running at a constant speed by the governor.

(2) FF or REW

A positive voltage is supplied to IC405-2 in the FF mode, and in the REW mode, to IC405-3 (non-inverting input), when Q420 is saturated, and in the REW mode, to IC405-3 (non-inverting input), when Q419 is saturated. Therefore, the governor function does not operate and the motor turns forward or in reverse, depending on whether is supplied with an approximately -12 V or +12 V voltage.

(3) PAUSE switch pressed during FF or REW (i.e., CUE)

Q413 is turned ON and the input voltage to IC405 is decreased, and the motor speed is reduced to approx. 1/3 of that for FF or REW. The motor is kept running at a constant speed by the governor.

(4) FF or REW switch kept further pressed in state (3)

Since R477 is grounded through D431 or D432, the input voltage to IC405 is further decreased, and the motor speed is reduced to approx. 3/5 of that for CUE (approx. 1/5 of that for FF or REW).

The motor is kept running at a constant speed by the governor.

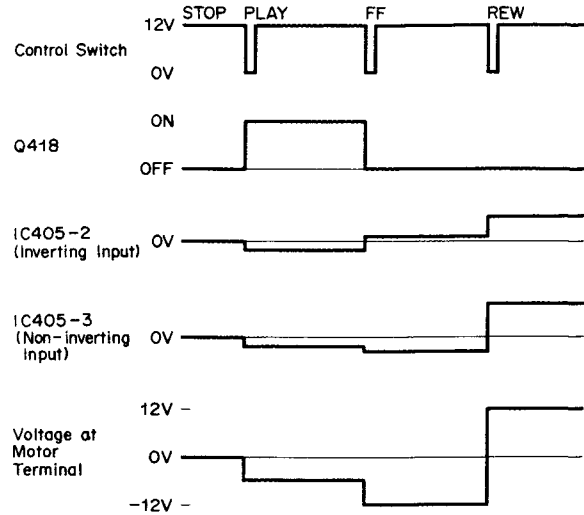

Fig. 2.3.25 Timing Chart

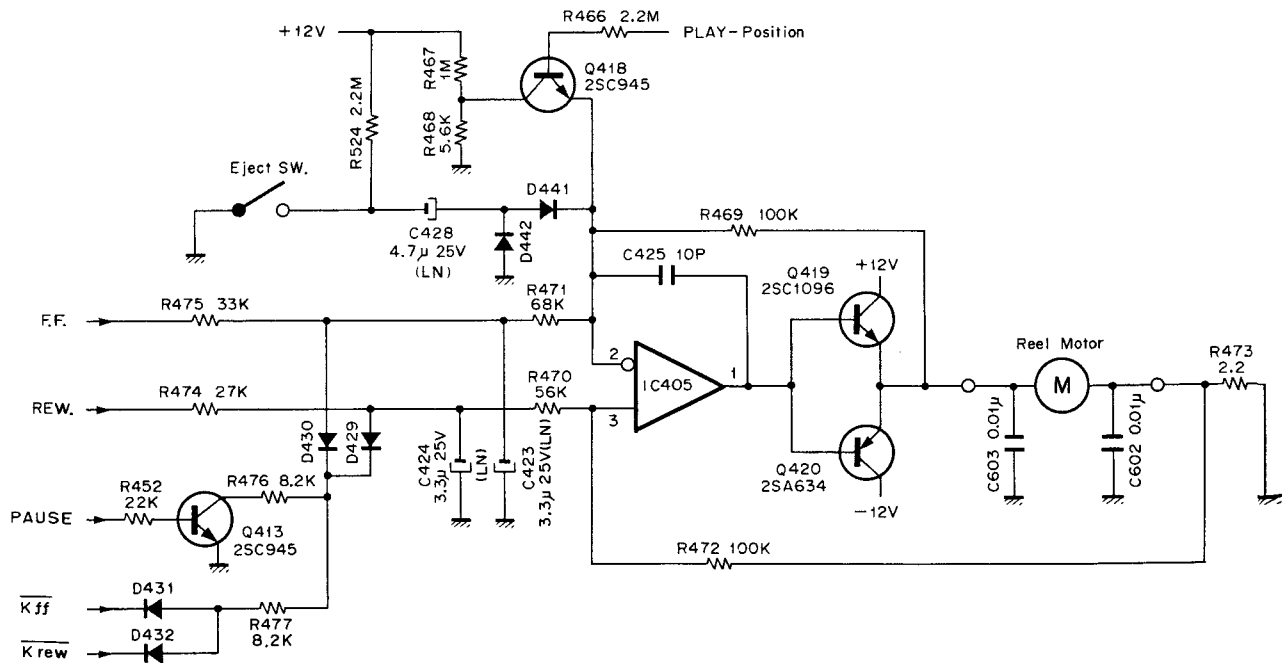

Fig. 2.3.24 Reel Motor Drive Circuit

2.4. Remote Control Unit RM-580 (Optional)

2.4.1. Introduction

The RM-580 is a remote controller for the N-581 consisting of a transmitter and a receiver. The transmitter transmits infrared control information which is received by a photosensitive diode in the receiver. The information is amplified and transmitted to the N-581 in order to control the tuning, volume, power supply and the auto-tuning of the N-581. See Fig. 2.4.1.

The control information is in the form of pulses with a frequency of approx. 22 kHz, transmitted with infrared rays.

Each unit of information consists of 7 bit and is transmitted in 10.5 ms. The first of the 7 bit is the start bit, the others being information bit. There is a time interval of 164 ms between each 7-bit unit of information and the next. See Fig. 2.4.2.

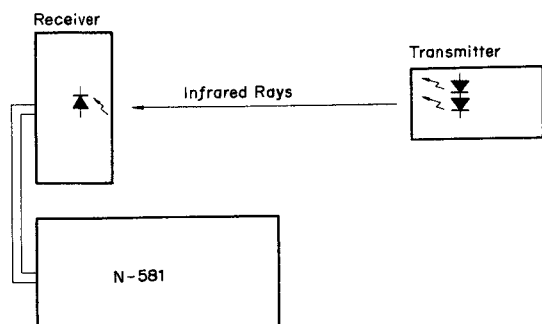

Fig. 2.4.1 RM-580 Connecting Diagram

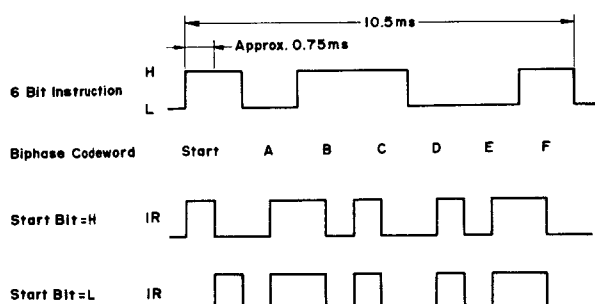

Fig. 2.4.2 Information Unit

2.4.2. Transmitter

The transmitter consists of a matrix key having various operation switches, a system IC for transmission, and an LED driving unit. See Fig. 2.4.3.

(1) Matrix key

The matrix key consists of six microswitches and six transistors: play, stop, rewind, f.f., record and pause.

(2) System IC for transmission

The system IC for transmission consists of IC901, the turn-ON transistor Q908, and an additional clock generator circuit.

Terminal No. 1 is connected to a positive power source and Terminal No. 6 is grounded through Q908. Since a battery is used in the RM-580 it is designed so that the power is consumed only when the matrix key is depressed and the information is transmitted.

When one of 1 to 8 and one of a to d of the keyboard scanning section of IC901 are shortcircuited, the turn-ON control section within the IC causes the voltage level at Terminal 7 of IC901 to become H. Then, Q908 is turned ON. Terminal 6 of IC901 is grounded, and the information is given from Terminal 8 through the output section. Terminals 2 to 5 correspond to a to d, and Terminals 9 to 16 correspond to 1 to 8 of the keyboard scanning section. If 1 and a of the keyboard scanning section are shortcircuited, a unit of information is generated, and if 1 and b are shortcircuited, another unit of information is generated. Thus, 32 kinds of information can be obtained from Terminal 8 through the output section. The external circuit of the clock generator used to make the pulses for information transmission is connected to Terminals 17 and 18 of IC901. The frequency is determined by the adjustment of L901.

(3) LED driver

The LED driver consists of Q909 and Q910 connected to Terminal 8 of IC901, and photodiodes D907 and D908. It converts the output information into infrared signals having considerable power.

The signal from Terminal 8 of IC901 becomes the base current of Q909 whose collector current is the base current of Q910 and the collector current from Q910 flowing to LED's D907 and D908 acts to transmit the information. D904, D905, D906, R925 and R926 compose a protective circuit to restrict the current to the LED's.

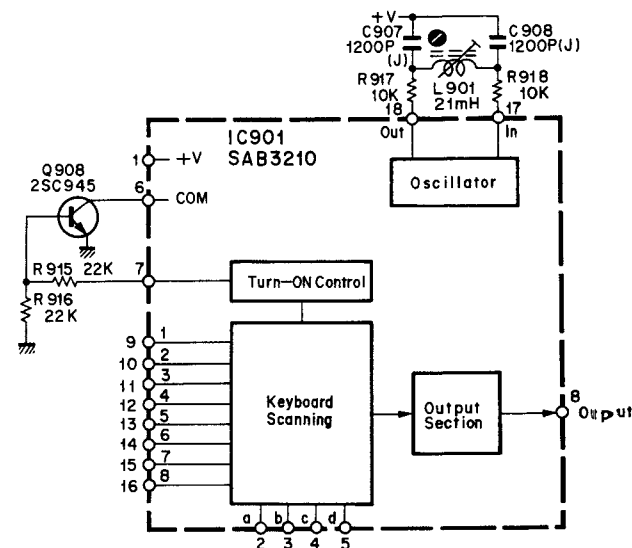

Fig. 2.4.3 Transmission IC System Diagram

2.4.3. Receiver

The receiver consists of a signal input, a signal amplifier, a system IC for reception, an instantaneous system IC power-disconnecting switch, a buffer amplifier, and an information processor.

(1) Signal input

The signal input consists of a photodiode D001, a transistor Q001 and a parallel resonance circuit.

The infrared signal radiated from the transmitter is received by the photodiode D001 and converted into a current. The current is amplified in the parallel resonance circuit consisting of C001, L001 and R001, and is further amplified by Q001.

The parallel resonance circuit is the most important part for remote control, and determines the distance at which remote operation is possible. This distance can be varied greatly by adjusting L002.

(2) Signal amplifier

The signal amplifier consists of IC004 and the surrounding circuits. IC004 is a specific frequency amplifier, operating at the information propagation frequency of approx. 22 kHz with an amplification of about 100 dB. This frequency is determined by R004, R005, R006, C004, C005 and C006.

(3) System IC for reception

The system IC for reception is IC003 shown in Fig. 2.4.4. Terminal 1 of IC003 is supplied with a positive power source and Terminal 17 is grounded. IC003 has a built-in clock-generator. An additional circuit is connected to Terminals 2 and 3 in order to make a frequency identical to that of the transmitter. The frequency can be adjusted by L002. The information signal from the transmitter is amplified by the signal amplifier and input at Terminal 15 of IC003. It is processed by a read-in register, and an output corresponding to the input is produced through program portion. Since the program portion has 4 kinds of output (A, B, C and D), 16 ($2^4 = 16$) kinds of output

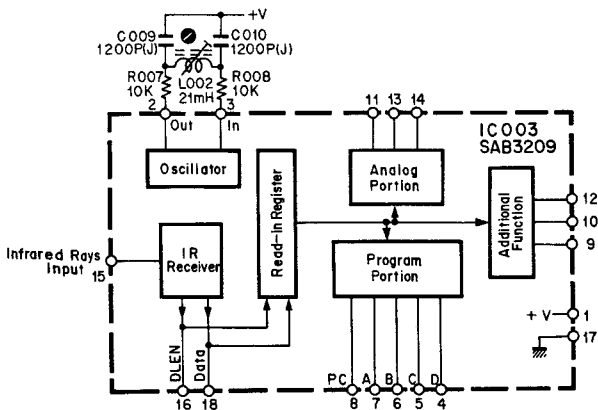

Fig. 2.4.4 Reception IC System Diagram

are produced. Terminal 8 of IC003 is called the PC terminal and is H only when an information signal is input.

(4) Instantaneous power-disconnecting switch function

See Fig. 2.4.5 timing chart.

The instantaneous power-disconnecting switch function for the system IC for reception consists of Q002, Q003, IC001-1,2,3, -4,5,6 and their peripheral circuit IC003 maintains its state when an information signal is output from the program portion, until the next unit of information is input. However, since the maintenance of this state affects the functioning of N-581, the information stored in the program portion must be cleared when the remote control button is released, and it is for this reason that the switching function of instantaneous power-disconnecting is provided to disconnect the power supply to IC003 and to clear the memory.

When an infrared signal is input through Terminal 15 of IC003, signal as shown in the figure are produced at Terminal 8, and fed into the base of Q002, as a result Q002 is turned ON.

The output signal of Q002 is given to the base of Q003 through inverters IC001-4,5,6 and -1,2,3. Q003 controls the power supply to IC003. When Q003 is turned ON, +12 V will be supplied to IC003, but when turned OFF, +12 V will no longer be supplied.

When a unit of information is finished, Q002 will not be turned ON, as a result C012 will be kept charging.

When the voltage of C012 exceeds the threshold level of IC001-5,6 (approximately half of applied +12 V), IC001-4 will become L and IC001-3 will become H. This way, H level is applied to the base of Q303 through C013, as a result Q003 will be turned OFF momentarily to disconnect the power supply to IC003, so that the program stored in IC003 will become cleared.

(5) Information processor

The information processor of C-MOS ICs IC001-8,9,10, -11,12,13, IC002-1,2,3, -4,5,6, -8,9,10, -11,12,13, Q004, Q005 and their peripheral circuits. It processes the 4-bit output signals from IC003 input as infrared information signals.

The table of information transmitted and the corresponding 4-bit signals output from IC003 is as follows:

Information	Signal Bit			
	A(7)	B(6)	C(5)	D(4)
Play	L	H	L	H
Stop	L	H	H	L
Rewind	H	L	H	L
F.F.	H	H	L	L
Record	L	L	H	H
Pause	H	L	L	H

As shown in the above table, there are 6 kinds of information to be transmitted, and when power source and grounding are included, 8 bus lines are required. Each command will be output to Logic P.C.B. Ass'y of the N-581 as shown below:

(a) Play

When both IC002-5 (B) and -6 (D) are made H's, IC002-4 becomes L and D005 is turned ON, as a result $\overline{\text{Play}} = \text{L}$ signal is output and Play will be activated.

(b) Stop

When both IC002-12 (B) and -13 (C) are made H's, IC002-11 becomes L and D003 is turned ON, as a result $\overline{\text{Stop}} = \text{L}$ signal is output and Stop will be activated.

(c) Rewind

When both IC001-8 (A) and -9 (C) are made H's, IC001-10 becomes L and D007 is turned ON, as a result $\overline{\text{Rewind}} = \text{L}$ signal is output and Rewind will be activated.

(d) F.F. (Fast Forward)

When both IC002-1 (A) and -2 (B) are made H's, IC002-3 becomes L and D006 is turned ON, as a result $\overline{\text{F.F.}} = \text{L}$ signal is output and F.F. will be activated.

(e) Pause

When both IC002-8 (D) and -9 (A) are made H's, IC002-10 becomes L and D004 is turned ON, as a result $\overline{\text{Pause}} = \text{L}$ signal is output and Pause will be activated.

(f) Record

When both IC001-12 (C) and -13 (D) are made H's, IC001-11 becomes L, and Q004 is turned ON, and then Q005 is turned ON with a certain time delay through C015, as a result $\overline{\text{Record}} = \text{L}$ is output and Record will be activated.

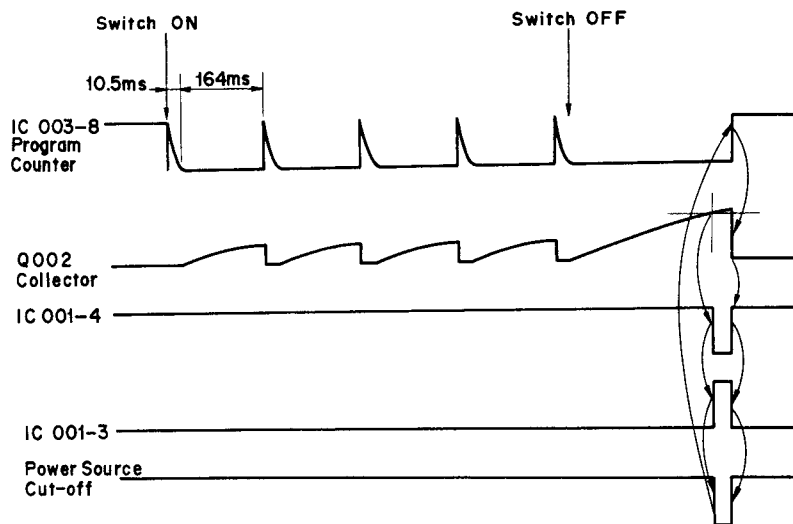

Fig. 2.4.5 Timing Chart

3. REMOVAL PROCEDURES

3.1. Acrylic Cassette Compartment Cover

Refer to Fig. 3.1.

- (1) Push the Eject Button to open the Cassette Case Ass'y.
- (2) Pull out F01 (Acrylic Cassette Compartment Cover) upwardly.

3.2. Top Cover Ass'y

Refer to Fig. 3.1.

Remove F02 and F03, then disassemble F04 (Top Cover Ass'y).

3.3. Bottom Cover Ass'y

Refer to Fig. 3.1.

Remove F05, then disassemble F06 (Bottom Cover Ass'y).

3.4. Front Panel Ass'y

Refer to Fig. 3.2.

- (1) Refer to Fig. 3.1. Remove Top Cover Ass'y and Bottom Cover Ass'y referring to items 3.2 and 3.3.
- (2) Remove F01 (VR Knobs) by pushing with a screwdriver or similar tools from the inside of the N-581.
- (3) Remove F02 (Switch Knobs) and F03, then disassemble F04 (Front Panel Ass'y including 2 connectors).

3.5. Mechanism Ass'y

Refer to Fig. 3.2.

- (1) Remove Front Panel Ass'y referring to item 3.4.
- (2) Remove F05, then disassemble F06 (Headphone Jack Ass'y).
- (3) Remove F07, then disassemble F08 (Mechanism Ass'y including 4 connectors).

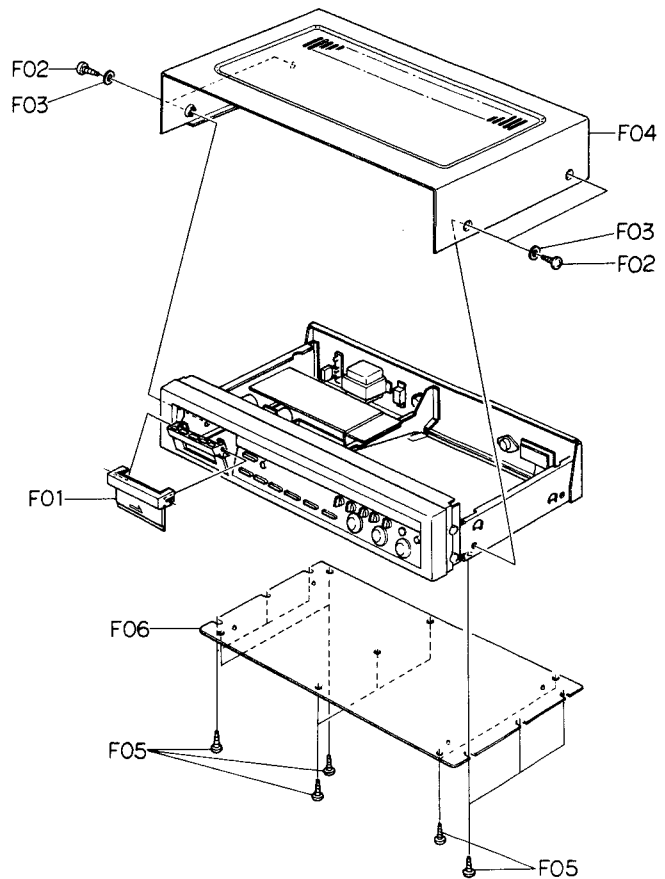

Fig. 3.1

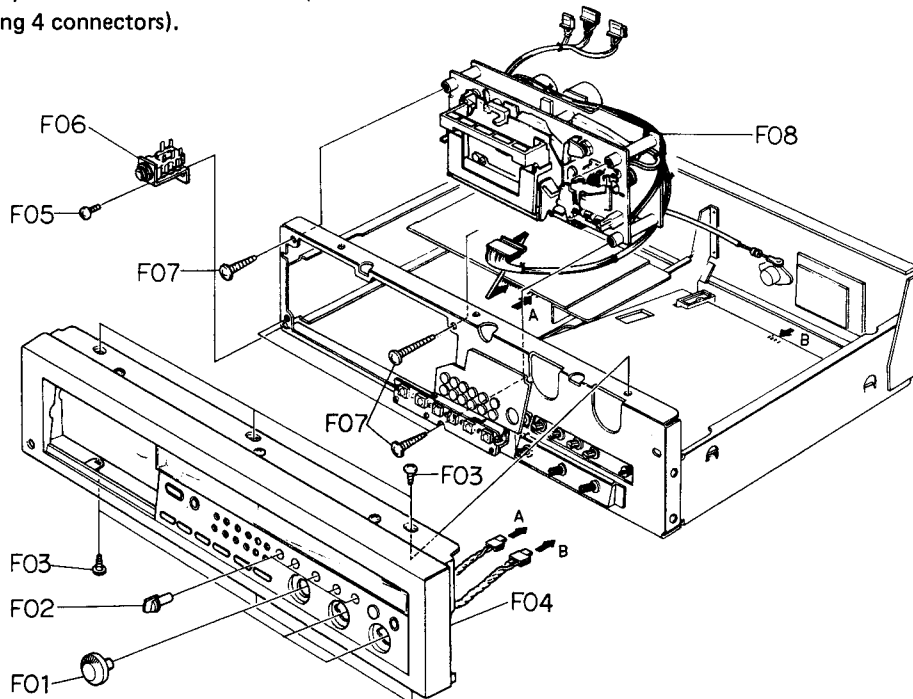

Fig. 3.2

3.6. Main P.C.B. Ass'y

Refer to Fig. 3.3.

- (1) Refer to Fig. 3.2. Remove Front Panel Ass'y referring to item 3.4.
- (2) Remove the flat cable, connectors and wires connected by wrapping from F04 (Main P.C.B. Ass'y).
- (3) Remove F01, F02, F03 and the Record Linkage Wire from the Wire Holder assembled with Record Switch, then disassemble F04 (Main P.C.B. Ass'y).

3.7. Logic P.C.B. Ass'y

Refer to Fig. 3.3.

- (1) Refer to Fig. 3.2. Remove Front Panel Ass'y referring to item 3.4.
- (2) Remove the connectors and wires connected by wrapping from F06 (Logic P.C.B. Ass'y).
- (3) Remove F05, then disassemble F06 (Logic P.C.B. Ass'y).

3.8. Power Switch

Refer to Fig. 3.3.

- (1) Remove Main P.C.B. Ass'y referring to item 3.6.
- (2) Remove F07 and F08, then disassemble F09 (Power Switch).

3.9. Volume P.C.B. Ass'y

Refer to Fig. 3.3.

- (1) Refer to Fig. 3.2. Remove Front Panel Ass'y referring to item 3.4.
- (2) Remove F10, then disassemble F11 (Volume P.C.B. Ass'y).

3.10. Control Button Ass'y

Refer to Fig. 3.3.

- (1) Refer to Fig. 3.2. Remove Front Panel Ass'y referring to item 3.4.
- (2) Remove F12, then disassemble F13 (Control Button Ass'y).

3.11. Record Cal. P.C.B. Ass'y

Refer to Fig. 3.3.

- (1) Refer to Fig. 3.2. Remove Front Panel Ass'y referring to item 3.4.
- (2) Remove F14, then disassemble F15 (Record Cal. P.C.B. Ass'y).

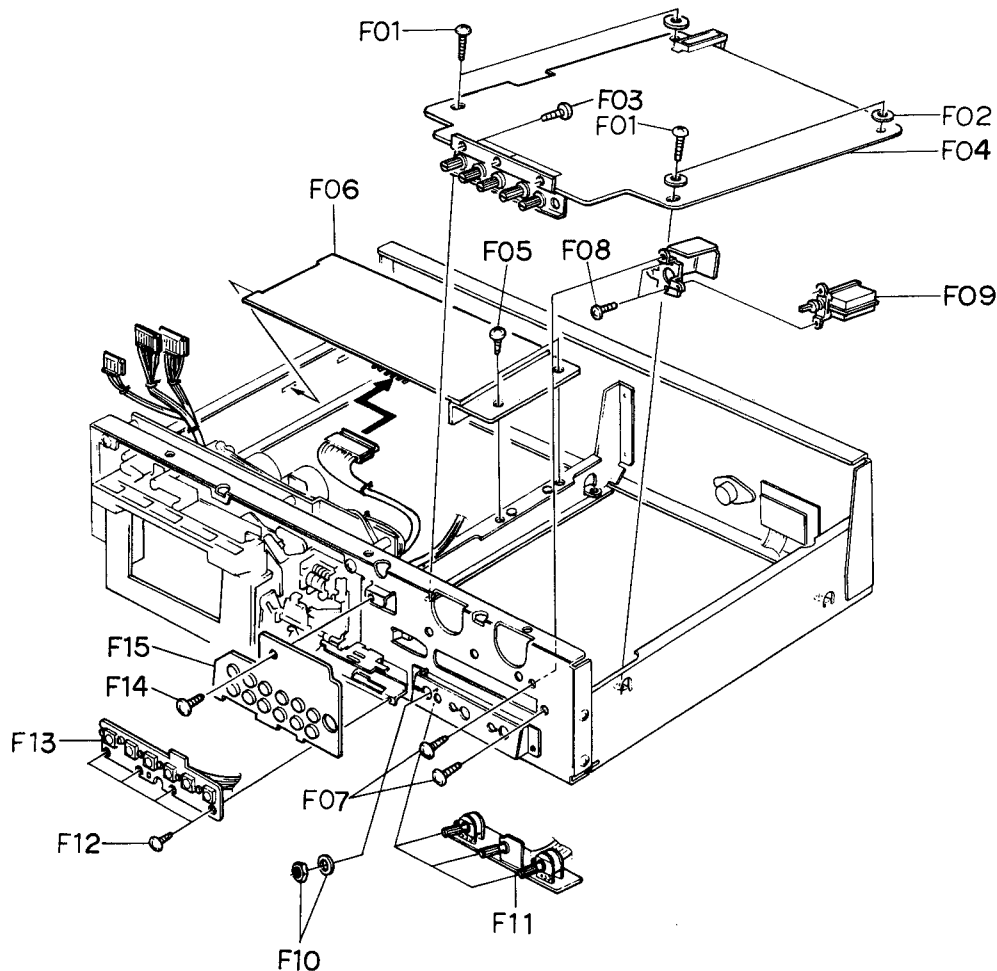

Fig. 3.3

3.12. Meter Ass'y

Refer to Fig. 3.4.

- (1) Refer to Fig. 3.2. Remove Front Panel Ass'y referring to item 3.4.
- (2) Remove F01 and F02, then disassemble F03 (Meter Ass'y).

3.13. Lamp P.C.B. Ass'y

Refer to Fig. 3.4.

- (1) Remove Meter Ass'y referring to item 3.12.
- (2) Remove F04, then disassemble F05 (Lamp House Cover Ass'y).
- (3) Remove F06, then disassemble F07 (Lamp. P.C.B. Ass'y).

3.14. Aluminum Mirror

Refer to Fig. 3.4.

- (1) Remove Lamp House Cover Ass'y referring to item 3.13.
- (2) Remove F08, then disassemble F09 (Aluminum Mirror).

3.15. Rear Panel Ass'y

Refer to Fig. 3.5.

- (1) Refer to Fig. 3.1. Remove Top Cover Ass'y and Bottom Cover Ass'y referring to items 3.2 and 3.3.
- (2) Remove F01, F02 and F03, then disassemble F04 (Rear Panel Ass'y).

3.16. Power Transformer

Refer to Fig. 3.5.

- (1) Refer to Fig. 3.1. Remove Top Cover Ass'y and Bottom Cover Ass'y referring to items 3.2 and 3.3.
- (2) Remove F05, F06 and F07, then disassemble F08 (Power Transformer).

3.17. Cassette Case Ass'y

Refer to Fig. 3.6.

- (1) Refer to Fig. 3.2. Remove Mechanism Ass'y referring to item 3.5.
- (2) Push the Eject Button to open the Cassette Case Ass'y.
- (3) Remove F01, then disassemble the piston of the Air Damper Ass'y.
- (4) Remove F02 and F03, then disassemble F04 (Cassette Case Ass'y).

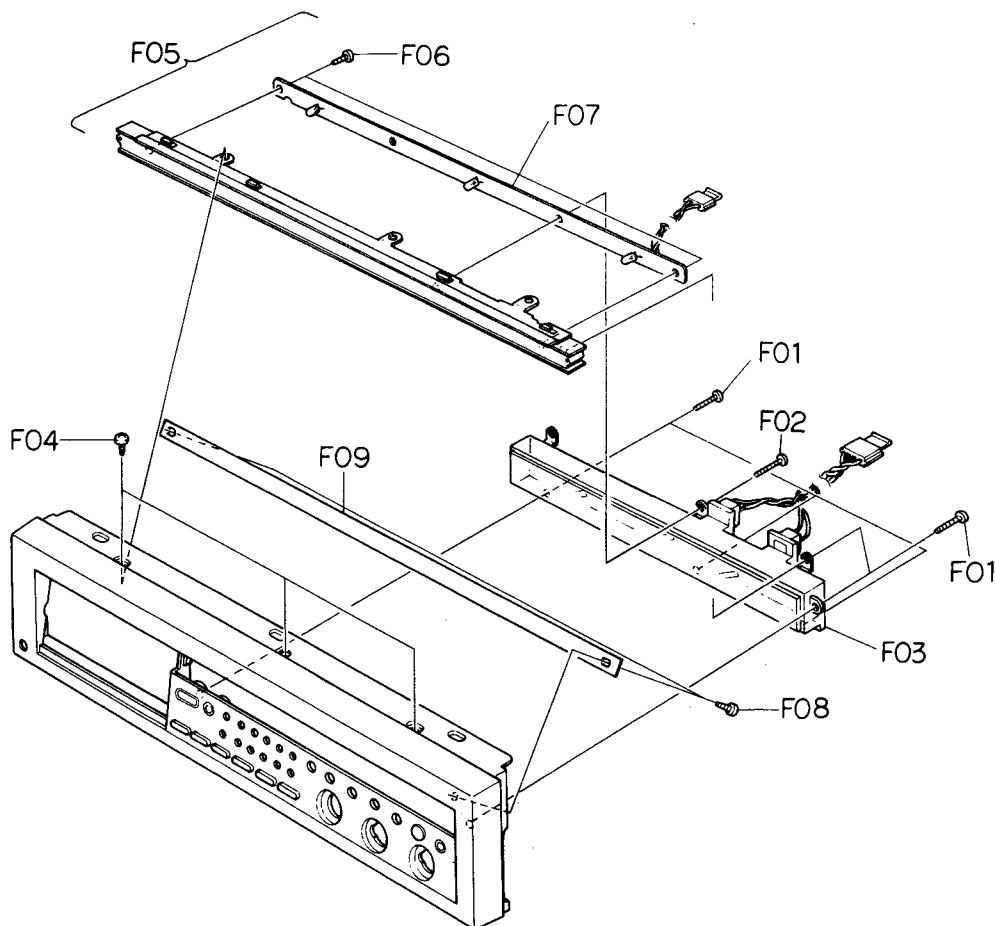

Fig. 3.4

3.18. Cover Plate

Refer to Fig. 3.6.

- (1) Refer to Fig. 3.2. Remove Front Panel Ass'y referring to item 3.4.
- (2) Push the Eject Button to open the Cassette Case Ass'y.
- (3) Remove F05, then disassemble F06 (Cover Plate).

3.19. Tape Counter Ass'y

Refer to Fig. 3.6.

- (1) Refer to Fig. 3.2. Remove Front Panel Ass'y referring to item 3.4.
- (2) Remove F07, then disassemble F08 (Tape Counter Ass'y).

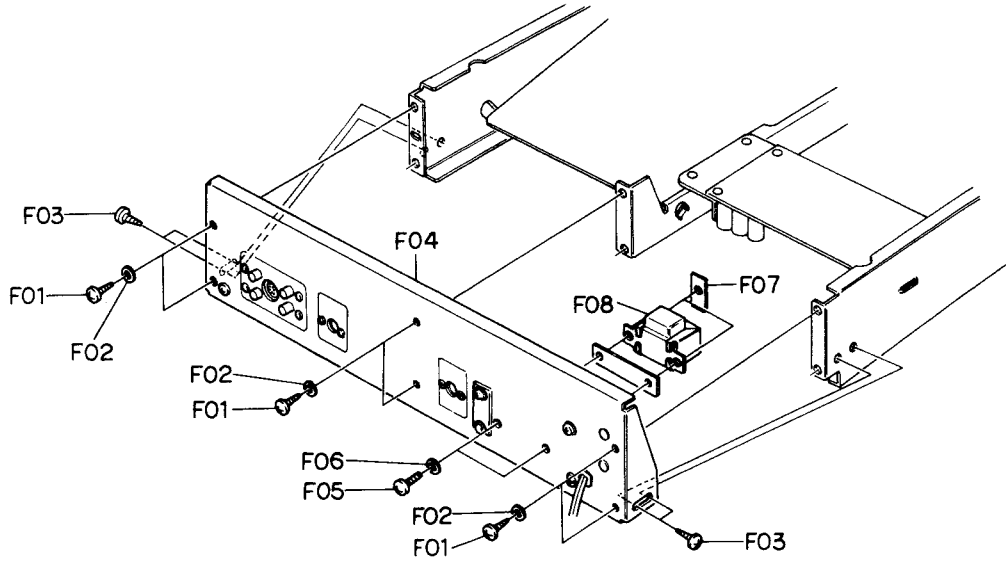

Fig. 3.5

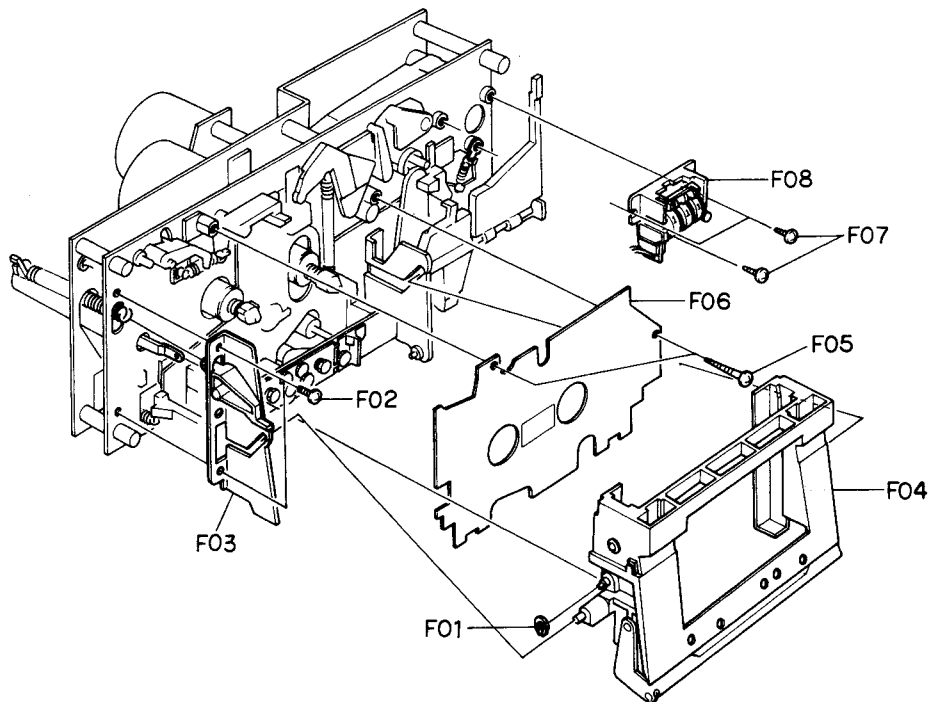

Fig. 3.6

3.20. Capstan Motor Ass'y and Flywheel Ass'y

Refer to Fig. 3.7.

- (1) Refer to Fig. 3.2. Remove Mechanism Ass'y referring to item 3.5.
- (2) Remove F01 and F02, then disassemble F03 (Flywheel Holder Ass'y) and F06 (Capstan Belt).
- (3) Remove F04, then disassemble F05 (Capstan Motor Ass'y).
- (4) Remove F07 (Supply Flywheel Ass'y), then disassemble F08 (Take-up Flywheel Ass'y).
- (5) After removing both Flywheel Assemblies, disassemble F09 (Thrust Washer 3.1 mm), F10 (Thrust Washer 2.6 mm), F11 (Flange Thrust Caps) and F12 (Flywheel Thrust Springs).

3.21. Sub Mechanism Chassis Ass'y

Refer to Fig. 3.8.

- (1) Refer to Fig. 3.2. Remove Mechanism Ass'y referring to item 3.5.
- (2) Remove Flywheel Holder Ass'y and both Flywheel Assemblies referring to above item 3.20.
- (3) Remove F01 and F02, then disassemble F03 (Sub Mechanism Chassis Ass'y).

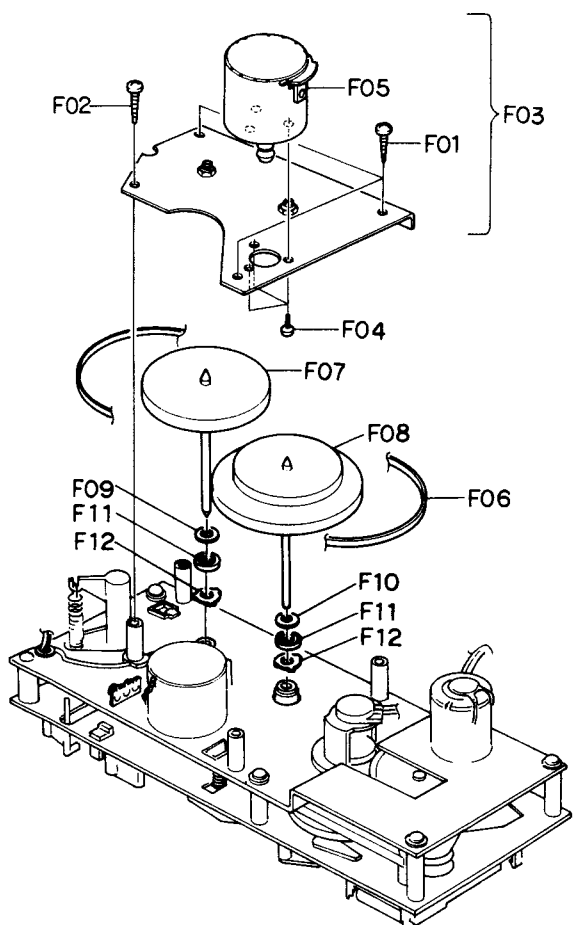

Fig. 3.7

3.22. Control Motor Ass'y

Refer to Fig. 3.8.

- (1) Remove Sub Mechanism Chassis Ass'y referring to item 3.21.
- (2) Remove F04, then disassemble F05 (Control Motor Ass'y).

3.23. Reel Motor Ass'y

Refer to Fig. 3.8.

- (1) Remove Sub Mechanism Chassis Ass'y referring to item 3.21.
- (2) Remove F06, then disassemble F07 (Reel Motor Ass'y).

3.24. Cam Control Volume

Refer to Fig. 3.8.

- (1) Remove Sub Mechanism Chassis Ass'y referring to item 3.21.
- (2) Remove F08, then disassemble F09 (Volume Coupler).
- (3) Remove F10, then disassemble F11 (Cam Control Volume).

3.25. Reel Hub Ass'y

Refer to Fig. 3.8.

- (1) Remove Sub Mechanism Chassis Ass'y referring to item 3.21.
- (2) Remove F12 (Reel Hub Heads).
- (3) Remove F13 (Reel Hub B Assemblies)
- (4) Remove F14 (Reel Hub Take-up Ass'y) and F15 (Reel Hub Supply Ass'y).
- (5) Remove F16 (Back Tension Felt) and F17 (Back Tension Spring) from the supply side Reel Hub Ass'y.

3.26. Idler Ass'y

Refer to Fig. 3.8.

- (1) Remove Sub Mechanism Chassis Ass'y referring to item 3.21.
- (2) Remove F18, then disassemble F19 (Idler Ass'y).

3.27. Cam Drive Gear and Cam

Refer to Fig. 3.8.

- (1) Remove Sub Mechanism Chassis Ass'y referring to item 3.21.
- (2) Remove F20, then disassemble F21 (Cam Drive Gear).
- (3) Remove F22, then disassemble F23 (Counter-Load Arm Ass'y).
- (4) Remove F24, then disassemble F25 (Cam).

3.28. Head Mount Base Ass'y

Refer to Fig. 3.9.

- (1) Refer to Fig. 3.6. Remove Cassette Case Ass'y referring to item 3.17.
- (2) Remove F01, then disassemble F02 (Head Mount Base Ass'y).

3.29. Supply Pressure Roller Ass'y

Refer to Fig. 3.9.

- (1) Remove Head Mount Base Ass'y referring to item 3.28.
- (2) Remove F03 and a washer, then disassemble F04 (Supply Pressure Roller Ass'y).

3.30. Erase Head

Refer to Fig. 3.9.

- (1) Remove Head Mount Base Ass'y referring to item 3.28.
- (2) Remove F05, then disassemble F06 (Erase Head).

3.31. Take-up Pressure Roller Ass'y

Refer to Fig. 3.9.

- (1) Remove Head Mount Base Ass'y referring to item 3.28.

- (2) Remove F07 and a washer, then F08 (Take-up Pressure Roller Ass'y).

3.32. Playback Head Ass'y

Refer to Fig. 3.9.

- (1) Remove Head Mount Base Ass'y referring to item 3.28.
- (2) Turn F09 by 90° by pushing it, then disassemble F10 (Playback Head Ass'y).

3.33. Record Head Ass'y

Refer to Fig. 3.9.

- (1) Remove Head Mount Base Ass'y referring to item 3.28.
- (2) Turn F11 by 90° by pushing it, then disassemble F12 (Record Head Ass'y).

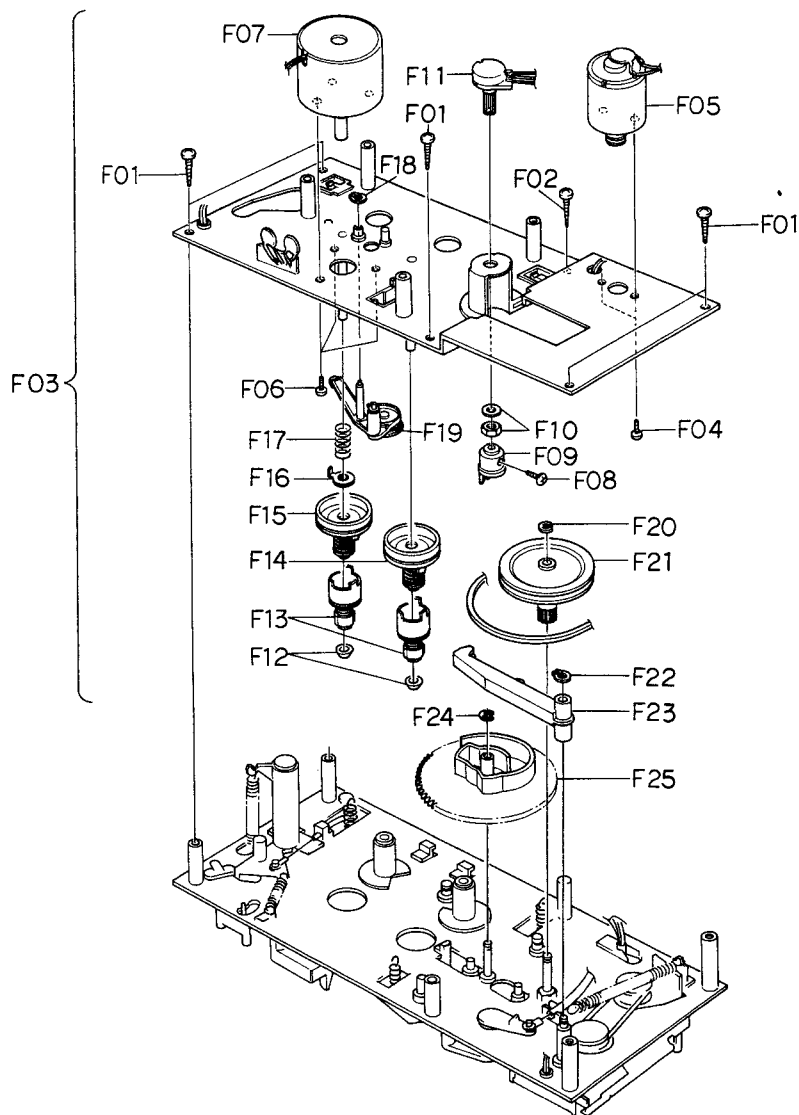

Fig. 3.8

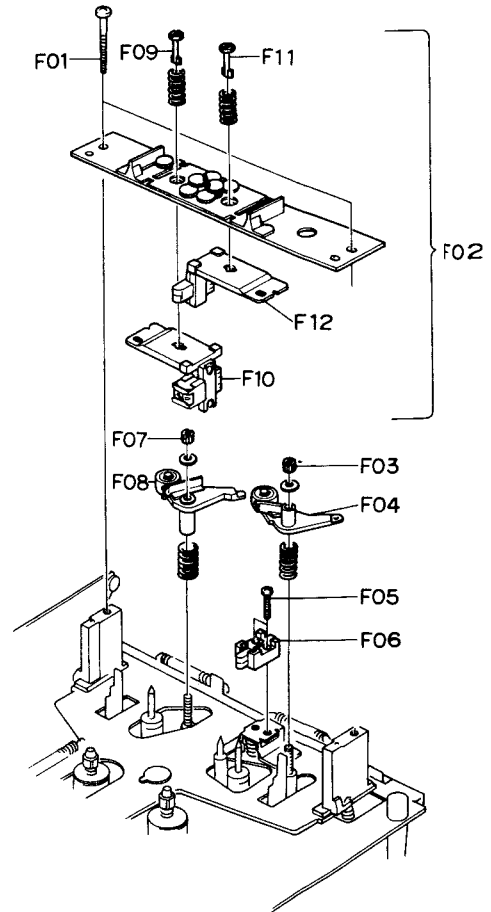

Fig. 3.9

4. MEASUREMENT INSTRUMENTS

- (1) Audio Generator (20 Hz – 200 kHz)
- (2) AC Milivolt Meter (with dB measures)
- (3) Oscilloscope (DC – 5 MHz)
- (4) Distortion Meter
- (5) Speed & Wow/Flutter Meter
- (6) Frequency Counter (DC – 1 MHz)
- (7) Ohm Meter
- (8) DC Volt Meter
- (9) AC Volt Meter
- (10) Torque Gauge (DA09013A)
- (11) 15 kHz Azimuth Tape (DA09004A)
- (12) 3 kHz Speed & Wow/Flutter Tape (DA09006A)
- (13) 1 kHz Track Alignment Tape (DA09007A)
- (14) 400Hz Level Tape (DA09005A)
- (15) 20 kHz PB Frequency Response Tape (DA09001A)
- (16) 15 kHz PB Frequency Response Tape (DA09002A)
- (17) 10 kHz PB Frequency Response Tape (DA09003A)
- (18) Reference EXII Tape (DA09021A)
- (19) Reference SX Tape (DA09025A)
- (20) Tilt Check Gauge M-9039 (DA09039A)
- (21) EH Tilt Check Gauge M-9040 (DA09040A)
- (22) EH Stroke Check Gauge M-9042 (DA09042A)
- (23) Stroke Check Gauge M-9047 (DA09047A)
- (24) Record Head Mounting Gauge M-9048 (DA09048A)
- (25) Audio Analyzer T-100
(including Distortion, Wow/Flutter, Speed, Oscillator and dB meter)

Note: (10) – (25) are the products of Nakamichi Corporation.

5. MECHANICAL ADJUSTMENTS

5.1. Mechanism Control Cam Adjustment

Before adjustment, disassemble the Front Panel Ass'y then remove the Cover Plate, referring to items 3.4 and 3.18.

(1) Offset Adjustment of Control Motor Driver

(a) Refer to Figs. 5.1 and 5.2.

Adjust VR402 and VR401 on the Logic P.C.B. to locate approximately at the middle of the variable range. Then turn ON the Power Switch.

VR402 (for Cam position stop)

VR401 (for Cam position play)

(b) Press the Stop Switch to set the N-581 in stop mode. Adjust VR402 (for stop) so that the "S" mark on the Cam corresponds to the pointer on the mechanism chassis.

(c) Press the Play Switch to set the N-581 in playback mode.

(Cam will rotate, and the position marked with "PY" comes to the pointer.)

Adjust VR401 (for play) so that the "PY" mark on the Cam corresponds to the pointer.

(d) Repeat above (b) and (c) 2 - 3 times so that the "S" and "PY" marks on the cam correspond to pointer accurately in stop and playback modes respectively. (This adjustment is required because the position adjusted by one volume will be slightly changed when the other volume is adjusted.)

(e) Set the N-581 in FF, pause, record, or cue mode by pressing each switch (press FF and Pause Switches to set the N-581 in cue mode) and check to insure that the pointer is in a range of "F", "PS", "R", or "CU" mark respectively.

(f) If out of the range, precise adjustment for each position according to "(2) Offset Fine Adjustment of Control Motor Driver" will be required.

(2) Offset Fine Adjustment of Control Motor Driver

Adjust only if a satisfactory result is not obtained in "(1) Offset Adjustment of Control Motor Driver".

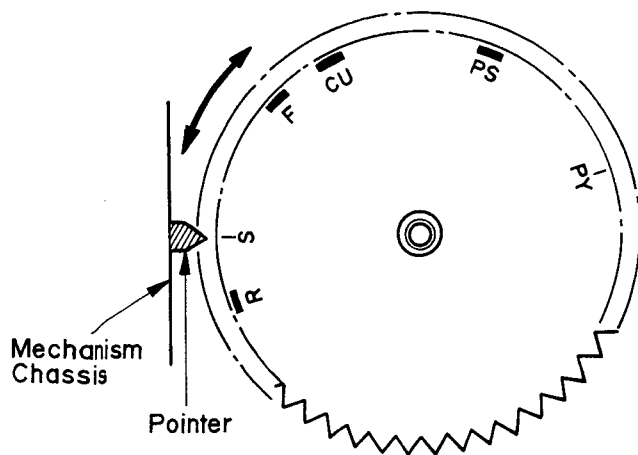

Fig. 5.1

This adjustment is made by changing the value of the fixed resistors on the Logic P.C.B. Voltages below shown are typical value.

(a) Observation Point of Reference Voltage

Observe the each voltage at the sliding contact of the Cam Control Volume VR601 (10 kΩ) in stop, fast (FF or REW), pause, record and playback modes.

Note: When Record and Play Switches are pressed to set N-581 in record mode, the Cam is first set to the record position in a short period of time then stays at the play position.

Therefore, to keep the Cam at the record position, following procedure is required:

Short the both leads of capacitor C426 (4.7 μF 25 V) on the Logic P.C.B. with a jumper wire, then press the Record and Play Switches.

(b) Reference Voltage

Reference voltage at the sliding contact of VR601 (Cam Control Volume) in each mode is as follows:

Mode	Reference Voltage (Typical Value)
Record	4.1 V
Stop	3.0 V
Fast (FF/REW)	1.3 V
Pause	-2.8 V
Playback	-5.4 V

Additional voltage ranges shown in the diagram:

- Record: 1.1 V ± 0.4 V
- Stop: 1.7 V ± 0.25 V
- Pause: 2.6 V ± 0.4 V

(c) Resistors for Adjustment

Mode	Ref. No.	Typical Value
Stop	R501	9.1 kΩ (F)
Fast (FF/REW)	R507	4.32 kΩ (F)
Pause	R514	287 kΩ (F)
Playback	R511	174 kΩ (F)
Record	R499	27 kΩ

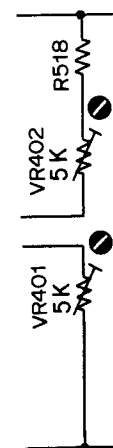

Fig. 5.2

(d) Adjustment Procedures

- 1) Press the Stop Switch to set the N-581 in stop mode. Adjust the value of R501 to obtain 3.0 V (± 0.6 V) at the sliding contact of VR601.

Note: When R501 is adjusted, the reference voltage in fast (FF or REW) mode is changed. Therefore, re-check of the reference voltage in fast (FF or REW) mode is required.

If the reference voltage is out of the range, re-adjustment of R507 according to next step 2) is necessary.

- 2) Set the N-581 in FF mode, then adjust the value of R507 so that the voltage of VR601 will become lower by 1.7 V (± 0.25 V) than in stop mode.
- 3) Press the Pause Switch to set the N-581 in pause mode.
Adjust the value of R514 to obtain -2.8 V ($+0.4$, -0.15 V) at the sliding contact of VR601.
- 4) Set the N-581 in playback mode, then adjust the value of R511 so that the voltage of VR601 will become lower by 2.6 V (± 0.4 V) than in pause mode.
- 5) Short the both leads of capacitor C426 with a jumper wire.

Set the N-581 in record mode, then adjust the value of R499 so that the voltage of VR601 will become higher by 1.1 V ($+0.4$, -0.2 V) than in stop mode.

Note: Remove the short of C426 after completion of adjustment.

(3) Cam Timing Adjustment

- (a) Remove the wires from the Control Motor Terminals to set the motor open.
- (b) Without loading a cassette tape and with pressing the Record Protecting Switch with your fingers, press the Record and Play Switches to set the N-581 in record mode.
- (c) Turn the Cam and bring the "PY" mark toward the pointer by hand.
Reel Motor will rotate before the "PY" mark reaches the pointer.
Adjust the value of R488 so that the voltage at sliding contact of VR601 becomes -3.6 V (± 0.3 V) when Reel Motor starts rotation.
- (d) Observe the mute signal at the Q424 collector. Turn the Cam referring to above step (c) and check to insure that the voltage at the sliding contact of VR601 is -3.8 V (± 0.3 V) when mute is released (mute signal changes from H to L).
(This voltage is determined by the adjustment of R488 in above step (c).)
- (e) Observe the Rec. signal at the Q421 collector. Turn the Cam referring to above step (c) and adjust the value of R480 to obtain -2.1 V (± 0.4 V) at the sliding contact of VR601 when Rec. signal changes from H to L (bias oscillation will begin).

- (f) Upon completion of above adjustment, re-connect wires to the motor terminals.

5.2. Tape Speed Adjustment

- (1) Remove the Top Cover.
- (2) Connect a Frequency Counter to the Output Jack.
- (3) Load a 3 kHz Speed Wow/Flutter Tape (DA09006A) and play it back.
- (4) Referring to Fig. 5.3, adjust the Tape Speed Adjustment Volume (VR501) incorporated in the Capstan Motor to obtain 3,000 Hz on the Frequency counter.
CCW: Motor drives slowly.
CW: Motor drives fast.

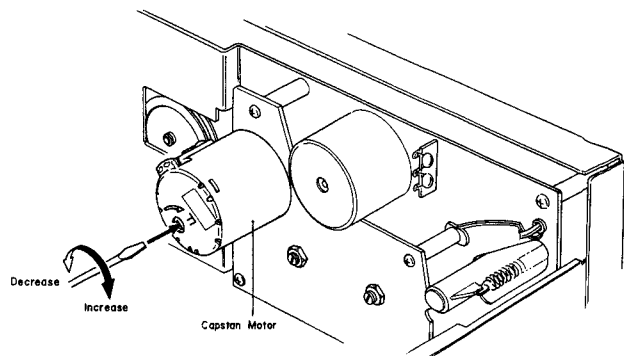

Fig. 5.3

5.3. Record Head and Playback Head Tilt Adjustment

Note: On items 5.3 – 5.8, please refer to Fig. 5.4 flow chart.

Refer to Figs. 5.5 and 5.6.

- (1) Load a Tilt Check Gauge M-9039 (DA09039A) in the N-581.
- (2) Clip the grounding terminal of the Tilt Check Gauge with one end of the cord with clip, and the other end to the chassis of the N-581.
- (3) Remove both of the Height Gears.
- (4) Set the N-581 in play mode. Check to insure whether the Beacons Playback Head "Upper" or "Lower" and Record Head "Upper" or "Lower" are illuminating. In order not to give damages onto the head surfaces, push both of slide knobs of the Gauge to the direction of arrow marks, then return it to the original place to be in contact with record head and playback head surfaces after play mode is securely locked.
- (5) Check to insure freedom from contact between the Gauge and pad lifter.
- (6) Beacon Playback Head "Lower" will light on when height adjustment screw (P) turned clockwise but Playback Head "Upper" when counterclockwise. Adjust so that both "Upper" and "Lower" will light on even when you move the slide knob to the direction of an arrow mark and then return it to the original place.

- (7) Same procedures will apply to the Beacons Record Head "Upper" and "Lower", except for the height adjustment screw (R).
- (8) Set the N-581 in stop mode and fit both of the ser-

rated height gears. Then set the N-581 again in play mode and insure all of the 4 Beacons are illuminating. If not, (3) through (7) will have to be repeated till satisfactory results are obtained.

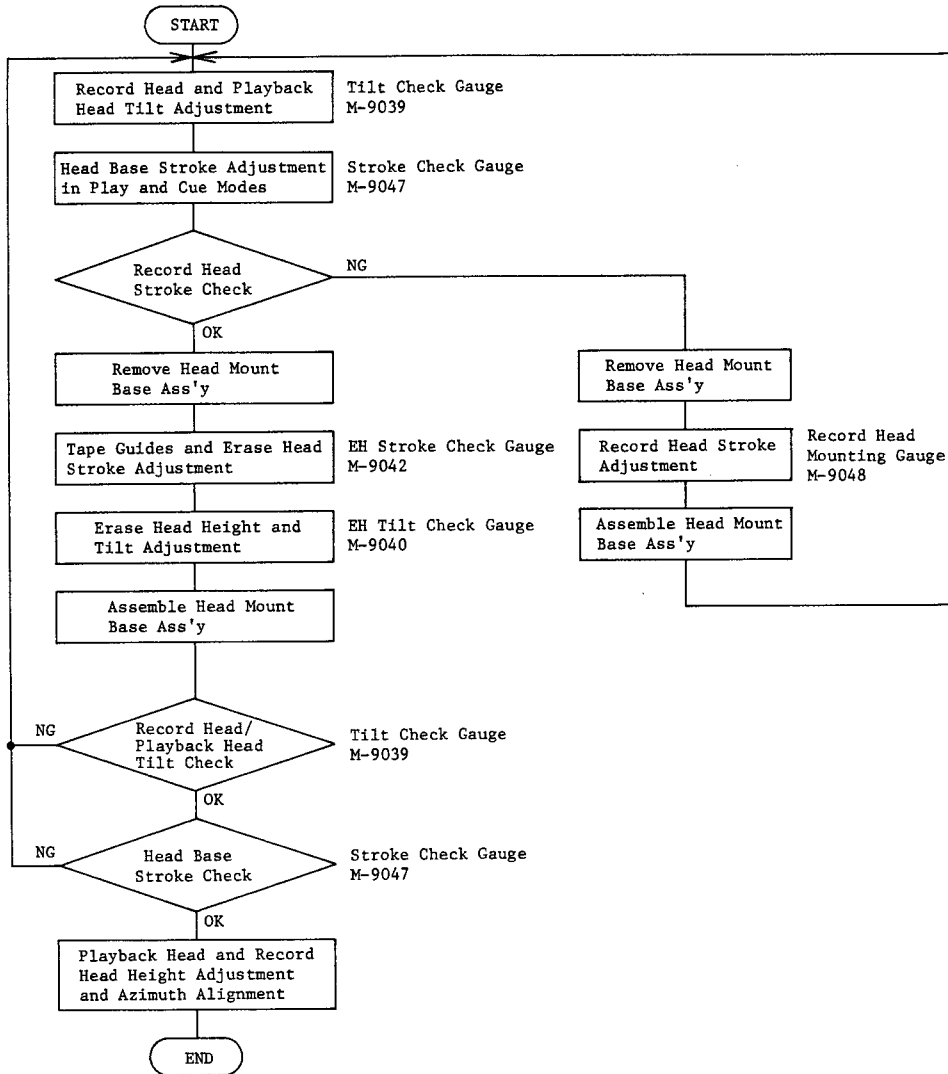

Fig. 5.4 Adjustment Flow Chart

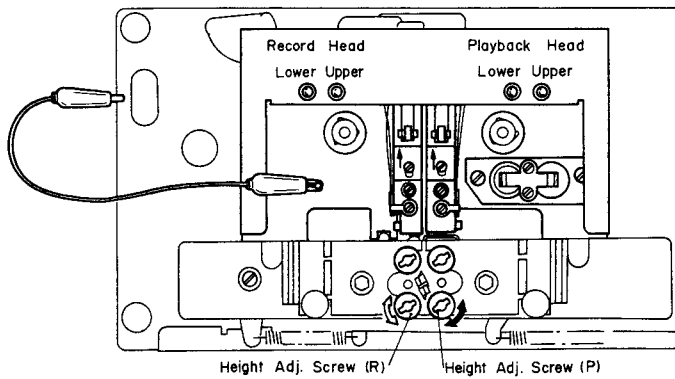

Fig. 5.5

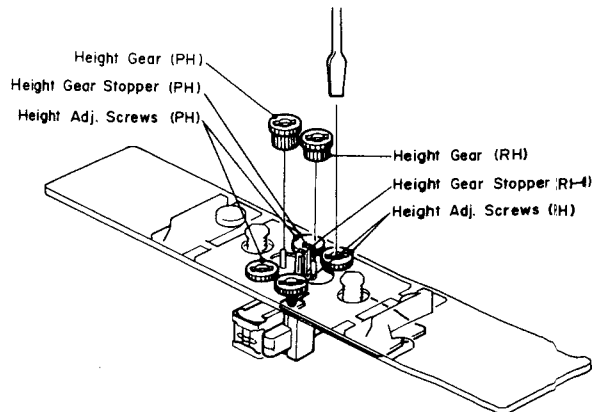

Fig. 5.6

5.4. Head Base Stroke Adjustment in Play and Cue Modes

Note: Before you conduct this adjustment, adjust with a "Tilt Check Gauge" to insure freedom from tilt on the playback head and record head.

(1) Head Base Stroke Adjustment in Play Mode

Refer to Fig. 5.7.

- Load a Stroke Check Gauge M-9047 (DA09047A) in the N-581.
- Move Record Head Indicator and Playback Head Indicator to the direction of arrow mark "A" with your finger tip and then set the N-581 in play mode. Then slowly release the Indicators and insure whether each of the Indicators is in contact with record and playback heads.
- Check to insure whether the "P" pointer on the Playback Head Indicator locates between the 2 lines on the Indicator Plate.
- If the playback head stroke is noted to be misaligned, adjustment can be made by moving the stroke adjuster assembled in the head base assembly (either forwardly or backwardly).
- Check to insure whether the "P" pointer on the Playback Head Indicator locates between the 2 lines on the Record Head Indicator, thus check can be made on record head stroke.

- If the record head stroke is noted to be misaligned, adjustment can be made with a Record Head Mounting Gauge M-9048 (DA09048A).

(2) Head Base Stroke Adjustment in Cue Mode

Refer to Fig. 5.8.

- Load a Stroke Check Gauge M-9047 (DA09047A) in the N-581.
- Move Record Head Indicator and Playback Head Indicator to the direction of arrow mark "A" with your finger tip and then set the N-581 in cue mode (F.F. and Pause). Then slowly release the Indicators and insure whether each of the Indicators is in contact with record and playback heads.
- Check to insure whether the "C" pointer on the Playback Head Indicator locates between the 2 lines on the Indicator Plate.
- If the playback head stroke is noted to be misaligned, adjust VR403 of the Logic P.C.B. Ass'y till satisfactory results are obtained.
- After completion of the Head Base Stroke Adjustment, check to insure accuracy of the Head Base Stroke Adjustment in play mode. If the above are inaccurate, items (1) and (2) will have to be repeated till satisfactory results are obtained.

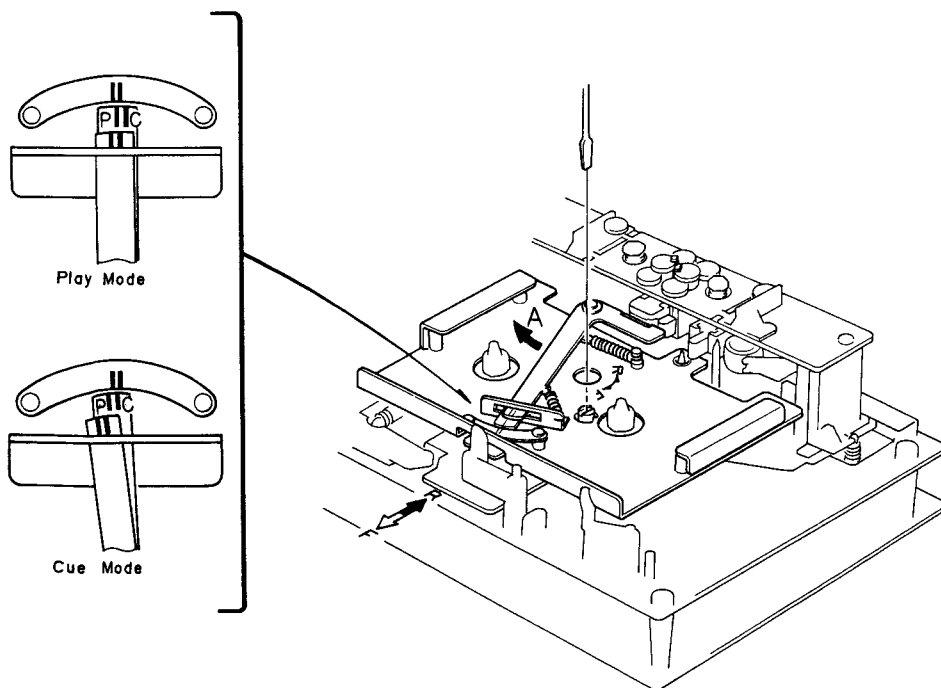

Fig. 5.7

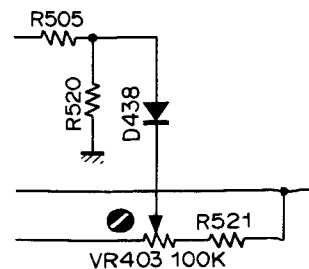

Fig. 5.8

5.5. Tape Guides Adjustment and Erase Head Stroke Adjustment

Remove Head Mount Base Ass'y referring to item 3.28. Refer to Figs. 5.9 and 5.10.

(1) Supply Tape Guide Height Adjustment

- (a) Load an EH Stroke Check Gauge M-9042 (DA09042A) in the N-581.
- (b) Set the N-581 in play mode.
- (c) Slide the Supply Tape Guide Check Bar down against the supply tape guide, thus check can be made on supply tape guide height.
- (d) If the supply tape guide is misaligned, the Supply Tape Guide Check Bar will not come into the supply tape guide. If such is noted, turn to adjust the height adjustment nut A till the Supply Tape Guide Check Bar is accepted by the supply tape guide.
- (e) If the above are insured, set the N-581 in pause mode, then in play mode to see whether adjustments are appropriately made. If not, (b) through (e) will have to be repeated till satisfactory results are obtained.

(2) Take-up Tape Guide Height Adjustment

- (a) Load an EH Stroke Check Gauge M-9042 (DA09042A) in the N-581.

- (b) Set the N-581 in play mode.
- (c) Slide the Take-up Tape Guide Check Bar down against the take-up tape guide, thus check can be made on take-up tape guide height.
- (d) If the take-up tape guide is misaligned, the Take-up Tape Guide Check Bar will not come into the take-up tape guide. If such is noted, turn to adjust the height adjustment nut B till the Take-up Tape Guide Check Bar is accepted by the take-up tape guide.
- (e) If the above are insured, set the N-581 in pause mode, then in play mode to see whether adjustments are appropriately made. If not, (b) through (e) will have to be repeated till satisfactory results are obtained.

(3) Erase Head Stroke Adjustment

- (a) Load an EH Stroke Check Gauge M-9042 (DA09042A) in the N-581.
- (b) Set the N-581 in play mode, thus check can be made on erase head stroke through the EH Stroke Indicator.
- (c) Check to insure whether the erase head surface is aligned with red line on the EH Stroke Indicator. If not, adjust the erase head stroke by loosening 2 screws that assembled erase head and erase head plate.
- (d) After completion of adjustment, 2 pcs. of screws shall be locked with lock tight paint.

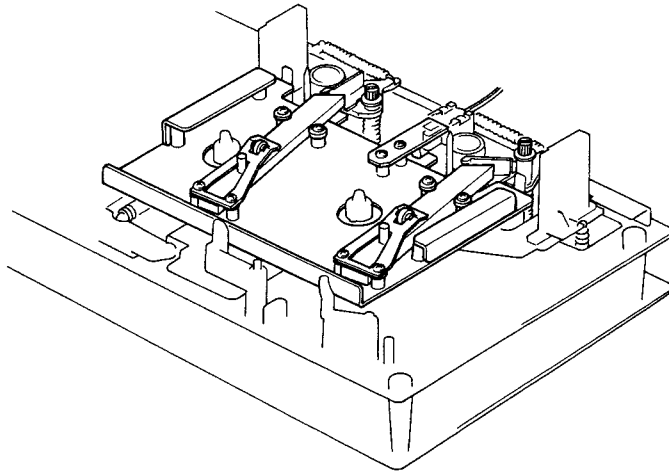

Fig. 5.9

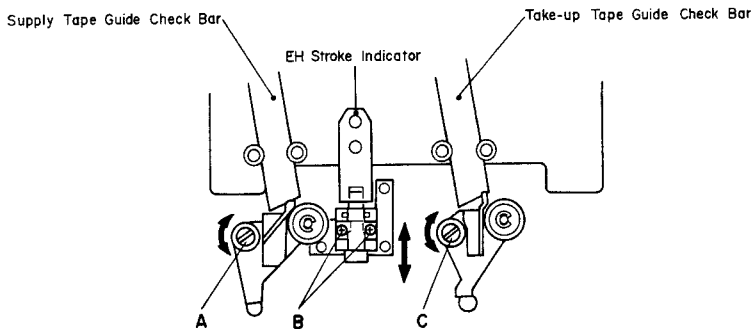

Fig. 5.10

5.6. Erase Head Height and Tilt Adjustment

Refer to Figs. 5.11 and 5.12.

- (1) Remove Head Mount Base Ass'y referring to item 3.28.
- (2) Load an EH Tilt Check Gauge M-9040 (DA09040A) in the N-581.
- (3) Set the N-581 in stop mode.
- (4) Check to insure whether one of the 3 Beacons is illuminating. Look down the mirror as shown by an arrow mark and slowly turn the Screw "Height" counterclockwise (or clockwise) so that the two horizontal lines of the mirror will become superposed on the line (in different color) of the erase head, and check to insure whether Beacon "1" is illuminating.
- (5) Turn Screw "Tilt" counterclockwise (or clockwise) to light on Beacon "2". Excessive turning will cause the Beacon "1" to light off. Adjustments of Screw

"Tilt" will therefore be conducted till both of the Beacons "1" and "2" illuminate.

- (6) Turn Screw "Azimuth" counterclockwise (or clockwise) to light on Beacon "3". Excessive turning will cause either Beacon "1" or "2" to light off, and therefore adjust with Screw "Azimuth" until all of the 3 Beacons, "1", "2" and "3" illuminate.
- (7) Check to insure whether the horizontal line on the mirror corresponds to that on the erase head. If not, (4) through (7) will have to be repeated till satisfactory results are obtained.
- (8) After completion of adjustment, 3 pcs. of screws shall be locked with lock tight paint.

Note: Before use of this gauge, check to insure freedom from dust or dirt, or overflow in the groove of the erase head surface.

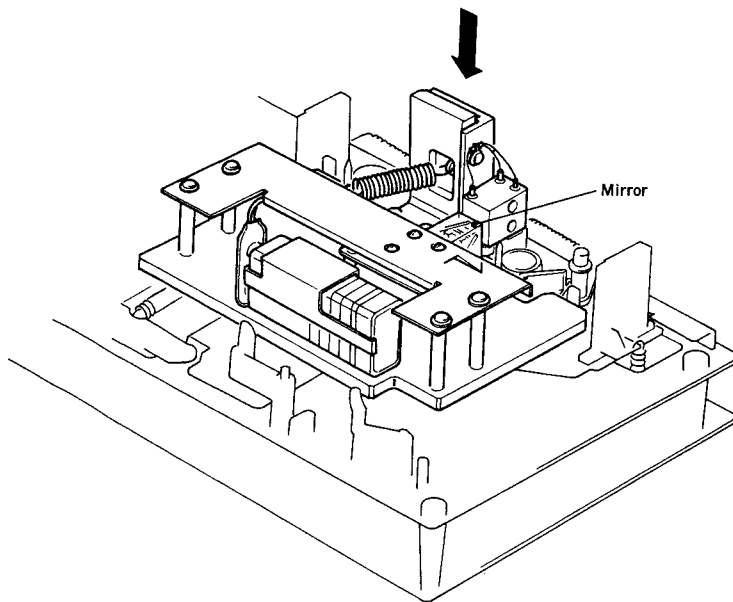

Fig. 5.11

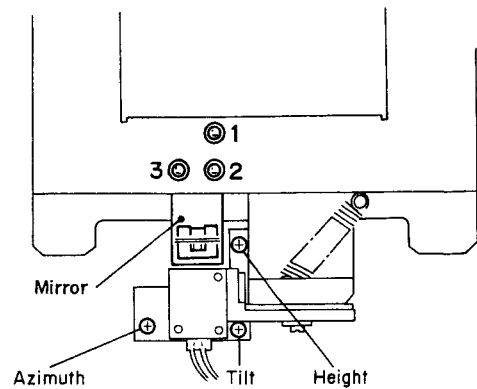

Fig. 5.12

5.7. Playback Head and Record Head Height Adjustment and Azimuth Alignment

Refer to Fig. 5.13.

(1) Playback Head Height Adjustment and Azimuth Alignment

- Place the Monitor Switch in the Tape position, then connect VTVM to the Output Jacks.
- Load a 1 kHz Track Alignment Tape (DA09007A), then set the N-581 in play mode.
- Turn the PH Height Gear until the output of both channels becomes minimum.
- Load a 15 kHz Azimuth Tape (DA09004A), then set the N-581 in play mode.
- Turn the PH Azimuth Alignment Screw until the output of both channels becomes maximum.
- Repeat (b) through (e) for 1 – 2 times.

(2) Record Head Height Adjustment and Azimuth Alignment

- Place the Monitor Switch in the Tape position, then connect VTVM to the Output Jacks.
- Load a Reference SX Tape (DA09025A). Set the Eq. and Tape Switches of the N-581 to 70 μ s and SX positions, then set the N-581 in record and play modes.
- Set the Tone Switch of the N-581 to 400 Hz, then turn the RH Height Gear until the output of both channels becomes maximum.
- Set the Tone Switch of the N-581 to 15 kHz, then turn the RH Azimuth Alignment Screw until the output of both channels becomes maximum.

- Repeat (c) and (d) for 1 – 2 times.
- After completion of both adjustment and alignment, record the 400 Hz tone to the same portion of both A and B sides of the tape.
- Immerse the recorded tape in a magnetized developing solution. In turn, check to insure that the recording head tracks across the center are separated with a distance of 0.55 to 0.75 mm (typically 0.65 mm) as illustrated in Fig. 5.14.

Note: Liquid for tape magnetized development solution

"MAGNA-SEE, SOUND CRAFT a product of CBS RECORDS a division of Columbia Broadcasting System, Inc., Danbury, Conn. 06810 U.S.A., or equivalent".

After development, clean the tape otherwise pressure rollers and heads will become dirty.

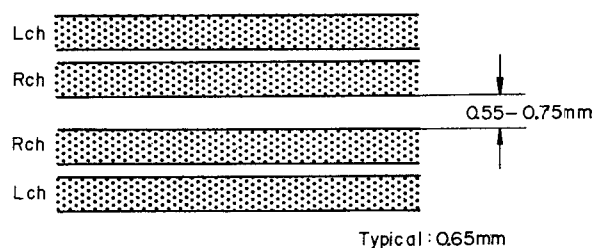

Fig. 5.14

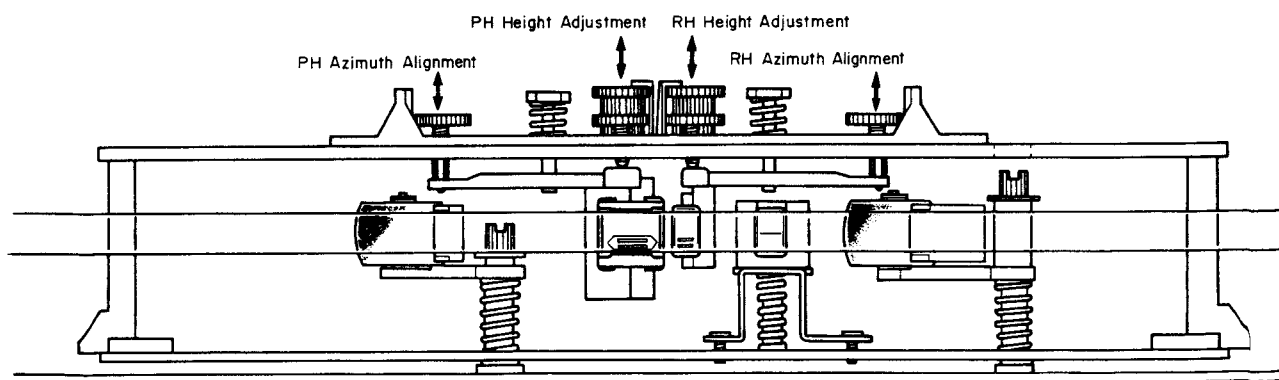

Fig. 5.13

5.8. Record Head Stroke Adjustment

Refer to Figs. 5.15 and 5.16.

Note: This adjustment will be required only to insure freedom from misalignment of the record head stroke in the record head stroke check mode.

- (1) Check the accuracy of the record head stroke.
- (2) Remove Head Mount Base Ass'y referring to item 3.28.
- (3) Remove the record head assembly.
- (4) Adjustment of Record Head Mounting Gauge M-9048 (DA09048A)
 - (a) Mount the Block B onto the Mounting Gauge Plate.
 - (b) Loosen the 2 screws fixing the Block A.
 - (c) As shown in the Fig. 5.15, hold the Gauges (3.05 mm and either one of 0.05, 0.15, 0.2, 0.25, 0.3 or 0.35 mm thickness) between the Block A and Block B, fix the Block A with screws, pushing the Block A to the 2 guide pins.
- (5) Remove the Block B from the Mounting Gauge Plate.
- (6) As shown in the Fig. 5.16, mount the R-54 record head assembly onto the Mounting Gauge Plate, then check the location of the R-54 record head surface. (If record head contacts to the Block C, loosen 2 pcs. of screws that assembled record head and R-54 record head assembly, then place the R-54 record head assembly onto the Plate.)
- (7) Remove the R-54 record head assembly from the Mounting Gauge Plate.
- (8) Readjustment of Record Head Mounting Gauge M-9048 (DA09048A)
 - (a) Mount the Block B onto the Mounting Gauge Plate.
 - (b) Loosen the 2 screws fixing the Block A.
 - (c) As shown in the Fig. 5.15, hold the Gauges (3.05 mm and either one of 0.05, 0.15, 0.2, 0.25, 0.3 or 0.35 mm thickness) between the Block A and Block B, fix the Block A with screw, pushing the Block A to the 2 guide pins.
- (9) Remove the Block B from the Mounting Gauge Plate.
- (10) Mount the R-54 record head assembly onto the Mounting Gauge Plate.
- (11) As shown in the Fig. 5.16, loosen the R-54 record head with 2 pcs. of screws onto the record head plate. As the location of the Block A is secured by the item (8) - (c), push the record head to the directions A and B, then tighten 2 pcs. of screws.
- (12) Check to insure freedom from gap between the Block C and record head surface, then tight the 2 pcs. of screws on the record head plate with lock tight paint.
- (13) Assemble the record head assembly to the head mount base assembly.
- (14) Assemble the head mount base assembly to the mechanism assembly.
- (15) Check the record head stroke.

If the above are inaccurate, items (1) through (15) will have to be repeated till satisfactory results are obtained.

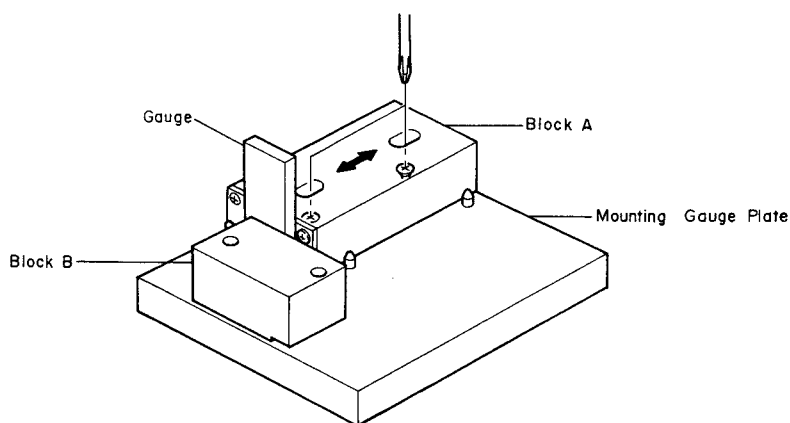
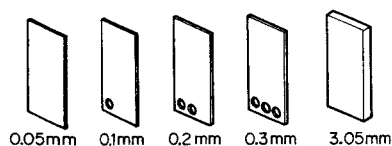

Fig. 5.15

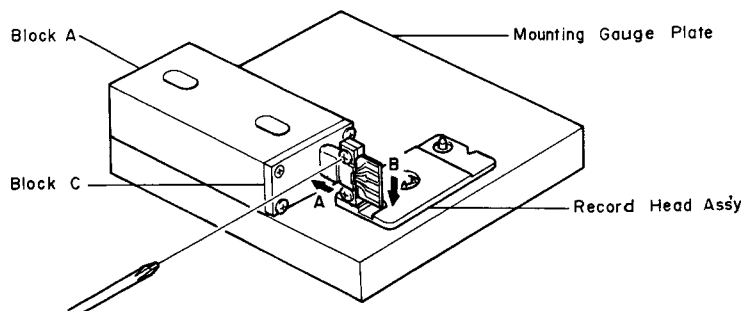

Fig. 5.16

5.9. Tape Travelling Adjustment

The adjustment shall be made with a modified version of the current type EXII C-90 as shown in Fig. 5.17 (error will be made if a current type Tape Travelling Cassette (DA09011A) should be used for this purpose).

While modifying an EXII C-90, the tape guides in the cassette housing shall be kept protected to avoid tilt. Check shall be made in the following procedures:

- (1) An EXII C-90 Tape thus modified shall be loaded onto the N-581.
- (2) Release the back-tension (rotate the Supply Reel and feed out some length of tape) and set the N-581 in play mode.
- (3) In this juncture, check to insure wheather the tape is free from waving or slippage from the tape guide.
- (4) When the modified EXII C-90 is played back, check to insure wheather the tape is freedom from waving from head surface or at pressure rollers.
- (5) If either of waving or slippage from the tape guide should be noted, adjustments of "5.3. Record Head and Playback Head Tilt Adjustment", "5.4. Head Base Stroke Adjustment", "5.5. Tape Guides Adjustment and Erase Head Stroke Adjustment", "5.6. Erase Head Height and Tilt Adjustment", "5.7. Playback Head and Record Head Height Adjustment and Azimuth Alignment", "5.8. Record Head Stroke Adjustment", etc. will be required.

As a case may be, the said waving or slippage may have been caused from defective supply Pressure Roller Ass'y or Take-up Pressure Roller Ass'y without parallel contact with capstans. If such are noted, the Pressure Roller Assemblies will have to be replaced.

Further, excessively weak take-up torque or strong take-up torque may cause defective tape travelling.

The N-581 is intended to be an adjustment-free Model, however if the similar matters as above should be noted, please replace the Reel Hub Ass'y to obtain appropriate take-up torque.

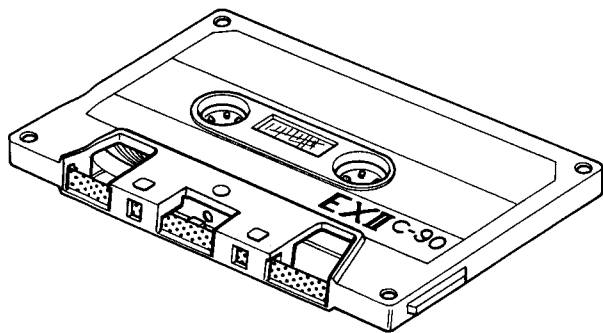

Fig. 5.17

5.10. Record Switch Linkage Adjustment

- (1) Set the N-581 in stop mode.
- (2) Loosen the screw of the Record Spring Holder, and shift the Record Spring Holder in order to remove the looseness of the Linkage Wire as shown in Fig. 5.18.1. Then tighten the screw for fixing the Record Spring Holder.
(In this case, the Record Switch should be positioned at Play side. If on the Record position, it will be defective.)
- (3) Set the N-581 in record and pause mode.
Check to insure that the gap between the top of the wire and the Record Spring Holder is approx. 1 mm as shown in Fig. 5.18.2.
(Check that the Record Switch is in Record position.)
- (4) Upon completion of the above adjustments, apply a quantity of lock tight paint.

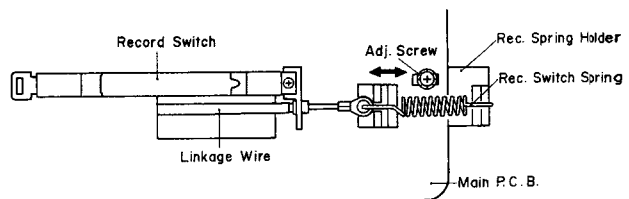

Fig. 5.18.1

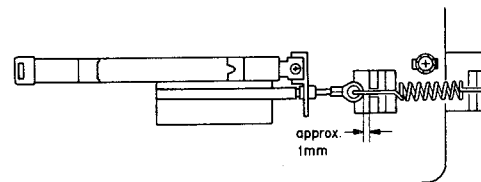

Fig. 5.18.2

5.11. Flywheel Holder Adjustment

(1) Refer to Fig. 5.19.

Tighten the Thrust Screws until the gap between the Flywheel Assemblies and Thrust Screws becomes minimized when both of the Capstan Shafts are moved backwardly and forwardly (the Thrust Springs between the Capstan Flanges and Flywheel Thrust Caps are in a flat state).

Excessive tightening of the Thrust Screws however will give damages on the Flywheel Assemblies, to which careful attention is invited.

(2) Return the Thrust Screws by 1/2 turn.

(3) Fixing the Thrust Screw with a screwdriver, lock the Lock Nut.

(4) Apply a quantity of lock tight paint to the Thrust Screws.

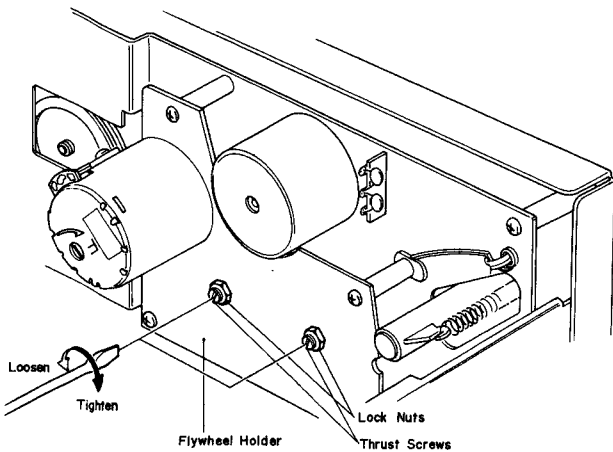

Fig. 5.19

5.12. Eject Wire Adjustment

(1) Referring to Fig. 5.20.1, insert a 1.5 mm spacer between the Eject Arm and Eject Stopper by turning the Eject Arm in the illustrated direction, then set the N-581 in playback mode.

(2) With pushing the Eject Arm by hand, loosen the screw and then pull the Eject Wire in the direction of the arrow until it stops as shown in Fig. 5.20.2.

(3) Tighten the screw, then apply a quantity of lock tight paint.

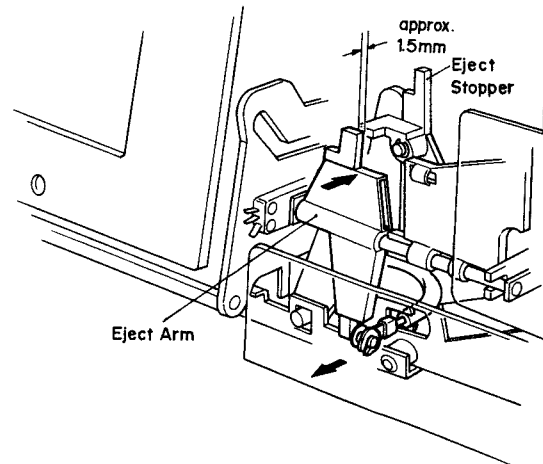

Fig. 5.20.1

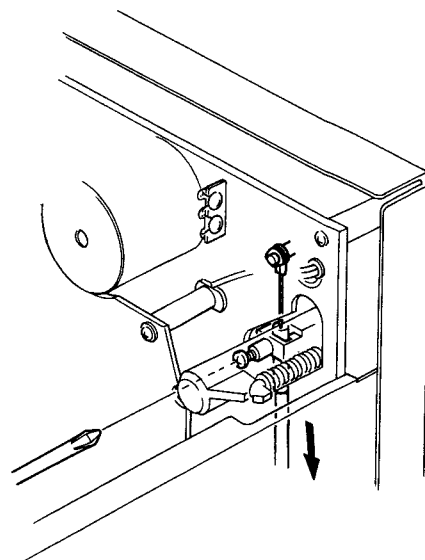

Fig. 5.20.2



5.13. Control Button Stroke Adjustment

Normal state of push button stroke for Logic Control on the Front Panel is as follows:

- (1) When Front Panel is in place, push the Control Button with a finger tip and see if it has an allowance of 0.6 mm. If it does, then push it a little further for another 0.4 mm and see if the switch is ON.
This allowance can be adjusted by loosening the screws that assembled Control Button Holder and Front Chassis together. After the adjustment, lock the screws with lock tight paint.
- (2) When performing adjustment, put the Front Panel aside, but for checking, do it with the Panel on.

5.14. Lubrication

N-581 is a lubrication-free cassette deck except when parts are replaced. Apply the following lubricant for each replaced part:

- (1) LAUNA #100
Capstan Shaft
Pressure Roller Shaft
Thrust Cap
- (2) FLOIL GB-TS-1
Reel Hub Shaft
Thrust portion on the Capstan Shaft
FLOIL GB-TS-1, made by Kanto Chemicals Co., Ltd., in Japan.
We suggest you use the above or equivalent type. If unavailable please contact Kanto Chemicals Co., Ltd., 2-7 Kanda Suda-cho Chiyoda-ku, Tokyo 101 Japan.
- (3) Silicon Oil #3000CST
Air Damper Piston
Note: Excessive lubrication may cause defective damper action as the 0.2ϕ hole at the end of the cylinder may be filled with oil.

6. ELECTRICAL ADJUSTMENTS AND MEASUREMENTS

6.1. Current Type (Serial No.: A30206060 -)

6.1.1. Parts Location for Electrical Adjustment

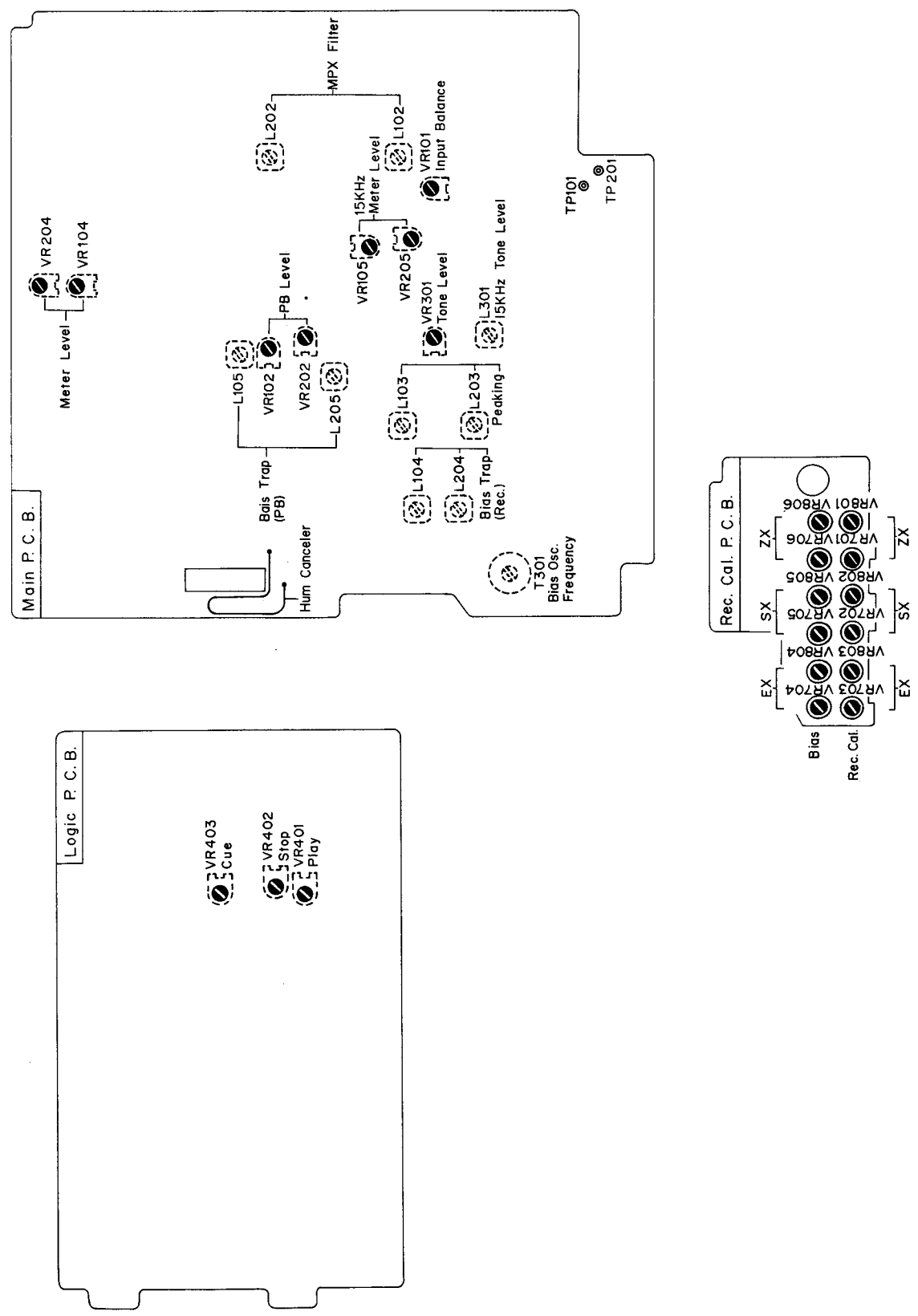

Fig. 6.1.1 Serial No.: A30206060 -

6.1.2. Electrical Adjustments and Measurements

(1) Adjustment and Measurement Instructions

Note: Electrical adjustment should be performed after mechanical adjustment is completed.

STEP	ITEM	SIGNAL SOURCE	OUTPUT CONNECTION	MODE	ADJUSTMENT	REMARKS
1	Tape Speed	3 kHz Speed and Wow/Flutter Tape (DA09006A)	Frequency Counter to OUTPUT Jacks	Playback	Capstan Motor Governor P.C.B. VR501	Adjust VR501 to obtain 3 kHz \pm 0.5%. (VR501 is incorporated in the Motor.)
2	Tone Calibration	Test Tone 400 Hz and 15 kHz	VTVM to TP101, TP201 on the Main P.C.B.	Test Tone SW – 400/15 k	Main P.C.B. VR301, VR101, L301	<ol style="list-style-type: none"> 1. Set the Test Tone Switch to 400 Hz. Turn output level control fully clockwise (maximum position). 2. Adjust VR301 to obtain 100 mV \pm 0.2 dB on the VTVM at TP201 (output will be 1 V (0 dB)). 3. Adjust VR101 to obtain the same level as Right channel on the VTVM at TP101. 4. Set the Test Tone Switch to 15 kHz. 5. Adjust L301 to obtain 10 mV \pm 0.5 dB on the VTVM. (output will be -20 dB against the level at 400 Hz).
3	Meter Level (400 Hz 0 dB)	400 Hz to INPUT Jacks	VTVM to TP101, TP201 on the Main P.C.B.	Record, Pause Tone SW – OFF	Main P.C.B. VR104, VR204	<ol style="list-style-type: none"> 1. Feed in 400 Hz (0 dB) and adjust record level controls to obtain 100 mV \pm 0.2 dB on the VTVM. Turn output level control fully clockwise (maximum position). 2. Adjust VR104 (VR204) to obtain 0 dB on the level meters (output will be 1 V (0 dB)). 3. Decrease input level by 10 dB/20 dB then short or open R160 (R260) and/or R161 (R261) to obtain minimum deviation from -10 dB/-20 dB on the level meters. (Perform at -10 dB and -20 dB.) 4. Again increase input level so that output will become 100 mV, then re-adjust VR104 (VR204) to obtain 0 dB on the level meters.

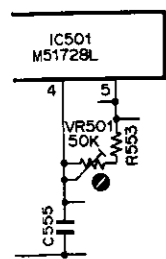

Fig. 6.1.2
1. Tape Speed

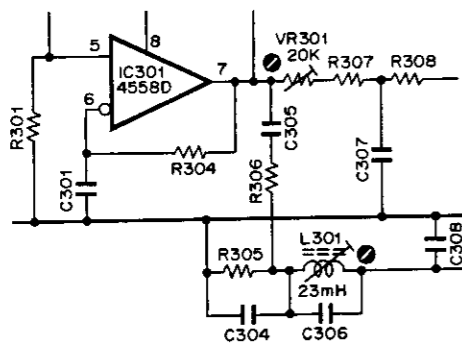

Fig. 6.1.3
2. Tone Calibration

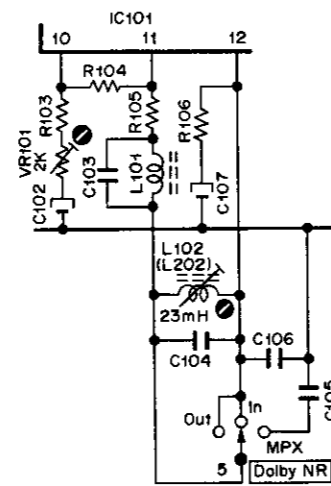

Fig. 6.1.4
2. Tone Calibration

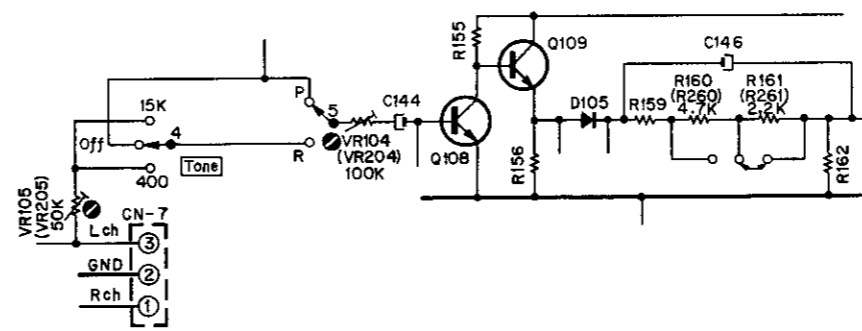

Fig. 6.1.5
3. Meter Level

STEP	ITEM	SIGNAL SOURCE	OUTPUT CONNECTION	MODE	ADJUSTMENT	REMARKS
4	MPX Filter	19 kHz \pm 100 Hz to INPUT Jacks	VTVM to OUTPUT Jacks	Test Tone SW — OFF Dolby NR SW — OUT, IN/MPX	Main P.C.B. L102, L202	1. Turn output level control fully clockwise (maximum position). 2. Adjust input level control to obtain 1 V on the VTVM. 3. Set the Dolby NR Switch to IN/MPX position, then adjust L102 (L202) to obtain minimum reading on the VTVM (minimum reading will be less than -30 dB).
5	Playback Head Track Alignment	1 kHz Track Alignment Tape (DA09007A)	VTVM to OUTPUT Jacks	Playback Test Tone SW — OFF Eq. SW — 70 μ s Dolby NR SW — OUT	Playback Head Height Adj. Screw	Adjust the Playback Head Height Adj. Screw to obtain minimum reading of both L and R channels on the VTVM. See "Playback Head Height Adjustment and Azimuth Alignment" in item 5.7.
6	Playback Head Azimuth Alignment	15 kHz Azimuth Tape (DA09004A)	VTVM to OUTPUT Jacks	Same as above	Playback Head Azimuth Alignment Screw	Adjust the Playback Head Azimuth Alignment Screw to obtain maximum reading of both L and R channels on the VTVM. See "Playback Head Height Adjustment and Azimuth Alignment" in item 5.7. Note: Repeat steps 5 and 6 one or two times to obtain optimum performance.
7	Playback Level	400 Hz Level Tape (DA09005A)	VTVM to TP101, TP201	Same as above	Main P.C.B. VR102, VR202	Adjust VR102 (VR202) to obtain 100 mV on the VTVM or 0 dB on the level meters.
8	Adjustment of Hum Canceler	Blank Tape	VTVM to OUTPUT Jacks	Playback Eq. SW — 70 μ s Dolby NR SW — IN/MPX	Main P.C.B. Hum Canceler (Jumper wire)	Adjust Hum Canceler to obtain minimum reading of R channel on the VTVM.
9	Playback Frequency Response	400 Hz Level Tape (DA09005A) 10 kHz PB Frequency Response Tape (DA09003A) 15 kHz PB Frequency Response Tape (DA09002A) 20 kHz PB Frequency Response Tape (DA09001A)	VTVM to OUTPUT Jacks	Playback Tape SW — SX Eq. SW — 70 μ s Dolby NR SW — OUT	Main P.C.B. R146, R246 R147, R247	1. Load the 400 Hz level tape and play it back. Adjust the output level control to a certain level (example 0 dB). 2. Load the 10 kHz, 15 kHz and 20 kHz PB frequency response tapes and adjust the playback head azimuth to give maximum levels on the VTVM with each tape. Short R146 (R246) and/or R147 (R247) to obtain the following level against 400 Hz level tape. Refer to Fig. 6.1.7. 10 kHz: -20 dB -1 dB to +2 dB 15 kHz: -20 dB -1 dB to +3 dB 20 kHz: -20 dB -1 dB to +4 dB 3. Conduct step 6 "Playback Head Azimuth Alignment". 4. If above is not sufficient, refer to "Playback Frequency Response Adjustment" in item 6.1.2(2).
10	Bias Oscillation Frequency and Erase Current	Connect an additional 0.1 Ω resistor in series to the Erase Head	VTVM and Frequency Counter across the additional 0.1 Ω resistor	Record, Pause Tape SW — ZX Eq. SW — 70 μ s Dolby NR SW — OUT	Main P.C.B. T301 R319, R341	1. Adjust T301 to obtain 105 kHz on the frequency counter. 2. Check the erase current by the VTVM. Erase current will be in a range of 310 mA to 400 mA (typically approx. 350 mA). If erase current is not sufficient, increase it by shorting R319 or R341. 3. After completion of the erase current adjustment, re-check the bias oscillation frequency.

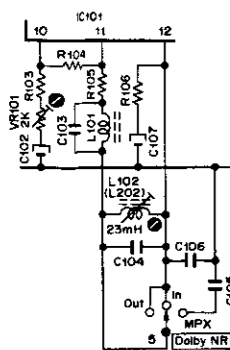

Fig. 6.1.6
4. MPX Filter

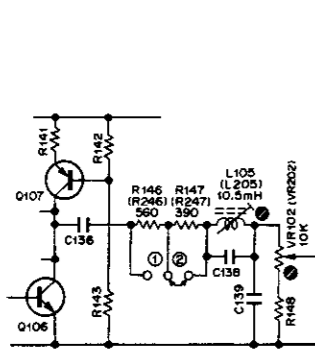

Fig. 6.1.7
7. Playback Level
13. Bias Trap (Playback Amp.)

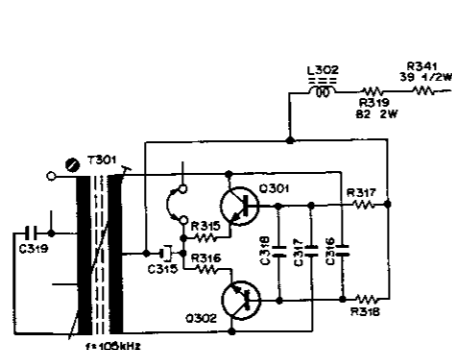

Fig. 6.1.8
10. Bias Oscillation Frequency and Erase Current

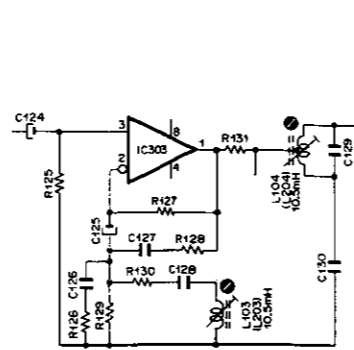

Fig. 6.1.9
11. Record Amplifier Equalizer
12. Bias Trap (Record Amp.)
17. Record/Playback Frequency Response

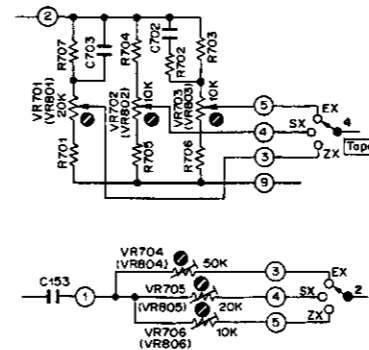

Fig. 6.1.10
16. Record Level and Recording Bias Current

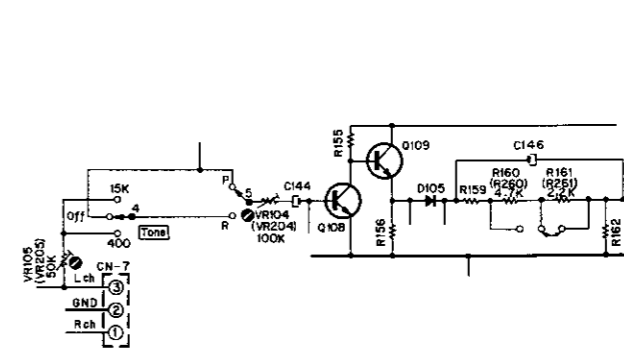

Fig. 6.1.11
18. Monitor Amplifier

STEP	ITEM	SIGNAL SOURCE	OUTPUT CONNECTION	MODE	ADJUSTMENT	REMARKS
11	Record Amplifier Equalizer	23 kHz (-20 dB) to INPUT Jacks	VTVM to Main P.C.B. CN5-1, CN5-3	Record, Pause Tape SW - ZX Eq. SW - 70 μ s Dolby NR SW - OUT	Main P.C.B. L103, L203	1. Remove the bias-cut-jumper from the dip side of the main P.C.B. 2. Adjust L103 (L203) to obtain peak reading at 23 kHz on the VTVM. 3. Re-solder the bias-cut-jumper.
12	Bias Trap (Record Amp.)	Remove Input Signals	Same as above	Same as above	Main P.C.B. L104, L204	Adjust L104 (L204) to obtain maximum reading on the VTVM.
13	Bias Trap (Playback Amp.)	Same as above	VTVM to Main P.C.B. CN7-3, CN7-1	Record, Pause Tape SW - ZX Eq. SW - 70 μ s Dolby NR SW - OUT	Main P.C.B. L105, L205	Adjust L105 (L205) to obtain minimum reading on the VTVM.
14	Record Head Height Adjustment	Test Tone 400 Hz	Same as above	Record, Playback Tape SW - SX Eq. SW - 70 μ s Dolby NR SW - OUT	Record Head Height Adj. Screw	Adjust the Record Head Height Adj. Screw to obtain maximum reading of L and R channels on the VTVM. See "Record Head Height Adjustment and Azimuth Alignment" in item 5.7.
15	Record Head Azimuth Alignment	Test Tone 15 kHz	Same as above	Same as above	Record Head Azimuth Alignment Screw	Adjust the Record Head Azimuth Alignment Screw to obtain maximum reading of L and R channels on the VTVM. See "Record Head Height Adjustment and Azimuth Alignment" in item 5.7.
16	Record Level Calibration and Recording Bias Current Adjustment	Test Tone 400 Hz and 15 kHz or 400 Hz and 15 kHz to INPUT Jacks	Same as above	Record, Playback Tape SW - EX/SX/ZX Eq. SW - 120 μ s (EX) 70 μ s (SX/ZX) Tone SW - 400 Hz/15 kHz Dolby NR SW - OUT	Rec. Cal. P.C.B. VR701, VR702, VR703, VR801, VR802, VR803, VR704, VR705, VR706, VR804, VR805, VR806	1. Set the Tone Switch to 400 Hz. 2. Record signals on the reference EXII tape (DA09021A), reference SX tape (DA09025A), or reference ZX tape (DA09037A), then play it back. 3. Adjust Rec. Cal. VR703 (VR803) (for EXII), VR702 (VR802) (for SX) and VR701 (VR801) (for ZX) to the center their positions. 4. Adjust Bias VR704 (VR804) (for EXII), VR705 (VR805) (for SX) and VR706 (VR806) (for ZX) to obtain maximum reading on the VTVM. 5. Set the Tone Switch to 15 kHz. 6. Adjust Bias VR704 (VR804), VR705 (VR805) and VR706 (VR806) to obtain the same readings as source monitor levels on the VTVM. 7. Set the Tone Switch to 400 Hz. 8. Adjust Rec. Cal. VR703 (VR803), VR702 (VR802) and VR701 (VR801) to obtain 0 dB on the level meters. 9. Repeat 5 through 8 as above two or three times to obtain optimum performance. 10. Check whether Total Harmonic Distortion (T.H.D.) is less than 1.0% for EXII and SX tapes, and 0.8% for ZX tape.
17	Record/Playback Frequency Response	400 Hz (0 dB) and 20 Hz to 20 kHz (-20 dB) to INPUT Jacks	Same as above	Record, Playback Tape SW - EX/SX/ZX Eq. SW - 120 μ s (EX) 70 μ s (SX/ZX) Tone SW - OUT Dolby NR SW - OUT	Main P.C.B. L103, L203	1. Feed in 400 Hz (0 dB) and adjust record level controls to obtain 0 dB on the level meters. 2. Switch the Generator output level to -20 dB, then record and play it back. 3. Feed in 20 Hz to 20 kHz (-20 dB), and check to insure if the output levels are within -20 dB \pm 3 dB. 4. If above is not sufficient, adjust L103 (L203) to obtain approx. -20 dB on the VTVM. 5. Conduct step 16 "Record Level Calibration and Recording Bias Current Adjustment". 6. If above is not sufficient, precise re-adjustment of step 9 "Playback Frequency Response", replacement of Playback Head or Record Head, or check on item 5.9 "Tape Travelling Adjustment" will be required.
18	Adjustment of Monitor Amplifier	Test Tone 400 Hz and 15 kHz		Record and Playback Tape SW - 400/15 k Tape SW - SX Eq. SW - 70 μ s Dolby NR SW - OUT	Main P.C.B. VR105, VR205	1. Set the Tone Switch to 400 Hz. 2. Load the reference SX tape (DA09025A), then record and play it back. Adjust VR105 (VR205) to obtain 0 dB on the level meters. 3. Set the Tone Switch to 15 kHz, then check to insure that the level meters flutter at 0 dB.

STEP	ITEM	SIGNAL SOURCE	OUTPUT CONNECTION	MODE	ADJUSTMENT	REMARKS
19	Crosstalk	1 kHz to INPUT Jacks	1 kHz Band Pass Filter, VTVM to OUTPUT Jacks	Record and Playback Tape SW - ZX Eq. SW - 70 μ s Dolby NR SW - OUT		<ol style="list-style-type: none"> 1. Erase the tape with bulk eraser. 2. Adjust record level controls to obtain 0 dB on the level meters, and record the signals on the reference tape. 3. Turn the cassette tape the other way round and play it back. 4. Measure the difference between 2 and 3.
20	Channel Separation	1 kHz to INPUT Jacks	Same as above	Same as above		<ol style="list-style-type: none"> 1. Erase the tape with bulk eraser. 2. Adjust Lch (Rch) record level control to obtain 0 dB on the level meter, and close Rch (Lch) record level control. 3. Record and play it back, then measure the Rch (Lch) level.
21	Erasure	1 kHz to INPUT Jacks	Same as above	Same as above		<ol style="list-style-type: none"> 1. Erase the tape with bulk eraser. 2. Adjust record level controls to obtain 0 dB on the level meters, and record the signals on the reference tape. 3. Rewind the tape then close record level controls. 4. Record and play it back, then measure the difference between 2 and 3.
22	Signal to Noise Ratio	400 Hz to INPUT Jacks	VTVM and Distortion Meter to OUTPUT Jacks	Record and Playback Tape SW - ZX Eq. SW - 70 μ s Dolby NR SW - IN/MPX		<ol style="list-style-type: none"> 1. Feed in 400 Hz and record, and play it back. 2. Adjust the record level controls to obtain 3% total harmonic distortion in playback mode. 3. Close the record level controls then record. 4. After rewind, play back and check the output level difference between 2 and 3. <p>Note: The filter of 1HF-A curve shall be used in the measurements.</p>
23	Total Harmonic Distortion	400 Hz to INPUT Jacks	Distortion Meter to OUTPUT Jacks	Record and Playback Tape SW - EX/SX/ZX Eq. SW - 120 μ s (EX) 70 μ s (SX/ZX) Dolby NR SW - OUT		<ol style="list-style-type: none"> 1. Adjust record level controls to obtain 0 dB on the level meters. 2. Record and play it back. 3. Read the distortion meter and check to insure that the distortion is less than 1.0% for EXII and SX tapes, and 0.8% for ZX tape.
24	Wow/Flutter	3 kHz Speed and Wow/Flutter Tape (DA09006A)	Wow/Flutter Meter to OUTPUT Jacks	Playback Monitor SW - Tape Eq. SW - 70 μ s		Playback and read the wow/flutter meter.

(2) Frequency Response Adjustment

(a) Playback Frequency Response Adjustment

Fig. 6.1.12 shows the playback equalization curve for N-581, and Fig. 6.1.13 is the circuit for adjustment.

1) Level Adjustment (for middle frequency response)

This adjustment will be required when playback level is not sufficient at 10 kHz PB Frequency Response Tape (refer to step 9 in "(1) Adjustment and Measurement Instructions").

Playback equalization level can be varied by the modification of R144 (R244) and R145 (R245).

Following are the details for level modification:

Approx. +1 dB	R145 (R245): 3.0K
	R144 (R244): 4.3K
0 dB	R145 (R245): 3.3K
	R144 (R244): 4.7K
Approx. -1 dB	R145 (R245): 3.6K
	R144 (R244): 5.1K

2) Peaking Adjustment (for high frequency response)

This adjustment will be required when playback level is not sufficient at 20 kHz PB Frequency Response Tape (refer to step 9 in "(1) Adjustment and Measurement Instructions").

Peaking portion compensates the gap loss of the playback head.

Peaking level is varied by the short circuit of R146 (R246) or R147 (R247) as illustrated in the figure.

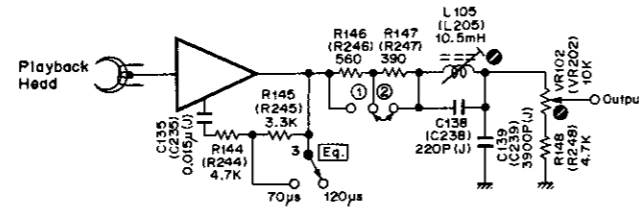

Fig. 6.1.13 Playback Amp.

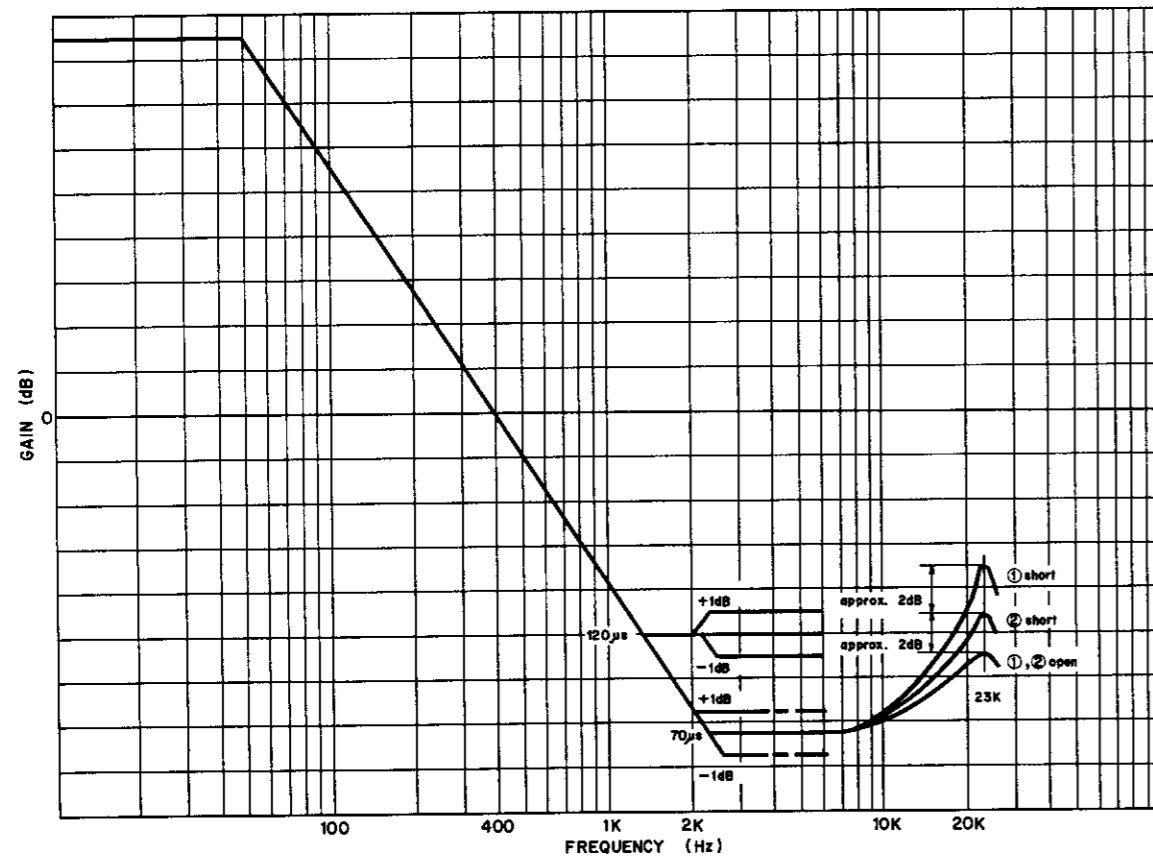

Fig. 6.1.12 Playback Equalization Curve

(b) Record Current Frequency Response Adjustment

Record Eq. peaking is adjusted for compensating the overall frequency response when playback frequency response is completed.

Normally however peaking frequency is pre-adjusted to approx. 23 kHz in Record mode. Refer to Fig. 6.1.14.

1) For ZX tape

a) Feed in 400 Hz (0 dB), then record and play it back. Adjust bias current by VR706 (VR806) to obtain a 0.8% distortion.

b) Feed in 10 kHz and 400 Hz (-20 dB) then record and play it back.

Check the difference of the levels between 10 kHz and 400 Hz, and mount an additional capacitor in parallel with the C122 (C222) from the dip side of the printed circuit board depending upon the difference of the levels against 400 Hz. Refer to Fig. 6.1.15.

	Add	Total
0 dB	0	1000 pF
-1 dB	470 pF	1470 pF
-2 dB	1000 pF	2000 pF

c) Feed in 20 kHz (-20 dB) then record and play it back.

Adjust record peaking coils L103 (L203) to obtain flat overall frequency response.

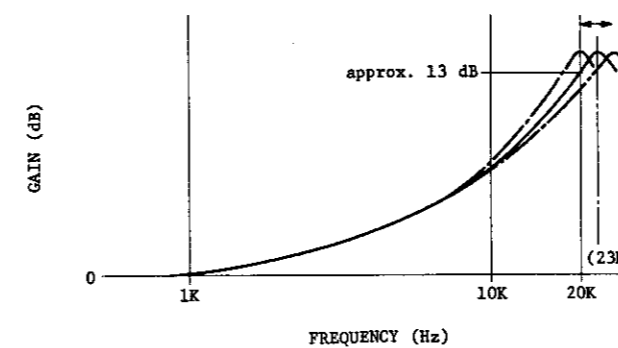

Fig. 6.1.14. Recording Peaking Curve

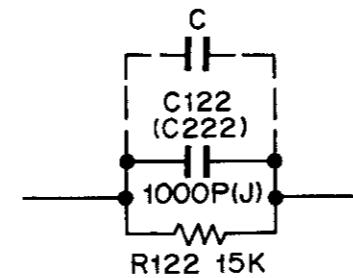

Fig. 6.1.15

2) For SX Tape

a) Feed in 15 kHz and 400 Hz (-20 dB), then record and play it back.

Adjust bias current by VR705 (VR805) to obtain flat overall frequency response.

b) Feed in 20 kHz and 400 Hz (-20 dB), then record and play it back.

And check to insure that the overall frequency response is flat.

3) For EX Tape

a) Feed in 15 kHz and 400 Hz (-20 dB), then record and play it back.

Adjust bias current by VR704 (VR804) to obtain flat overall frequency response.

b) Feed in 20 kHz and 400 Hz (-20 dB), then record and play it back.

And check to insure that the overall frequency response is flat.

(3) Dolby NR Circuit Check

Dolby NR circuit incorporates a Dolby B-Type NR IC (μ A7300PC) which has no adjustment point.

Perform the following checks and make sure that the IC operates accurately i.e. frequency response through IC is accurate.

Signal Source: 5 kHz to INPUT Jacks

Output Connection: VTVM to the output side of C119 (C219) on the Main P.C.B.

Mode: Record Pause
MPX SW - IN

(a) Remove the Bias-cut Jumper from the dip side of the Main P.C.B.

(b) Connect a VTVM to TP101 (TP201) on the Main P.C.B.

Feed in 5 kHz and adjust the input level so that the VTVM may read 100 mV (0 dB) at each Test Point. Pointer on the meter will indicate 0 dB.

(c) Remove the VTVM from TP101 (TP201) and reconnect it to the output side of C119 (C219). Check to insure that the VTVM indicates approx. 560 mV.

(d) Decrease the input level (0 dB) by 20 dB or 30 dB. Check to insure that the level at output side of C119 (C219) corresponds to the following with the Dolby NR Switch IN and OUT.

(e) After completion of the adjustment, reconnect the Bias-cut Jumper.

Input Level	Capacitor Output Level		
(f=5 kHz)	Dolby NR OUT	Dolby NR IN	Difference between IN and OUT
-20 dB	-20 dB	-16.8 dB \pm 1.5 dB	3.2 dB \pm 1.5 dB
-30 dB	-30 dB	-21.8 dB \pm 1.5 dB	8.2 dB \pm 1.5 dB

6.2 Previous Type (Serial Nos.: A30201001 – A30206059)

6.2.1. Parts Location for Electrical Adjustment

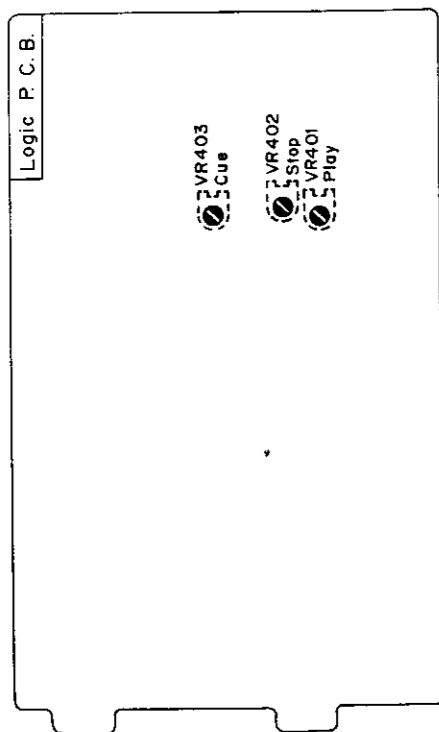
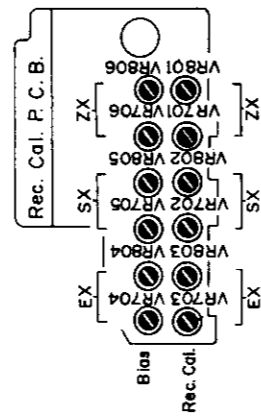
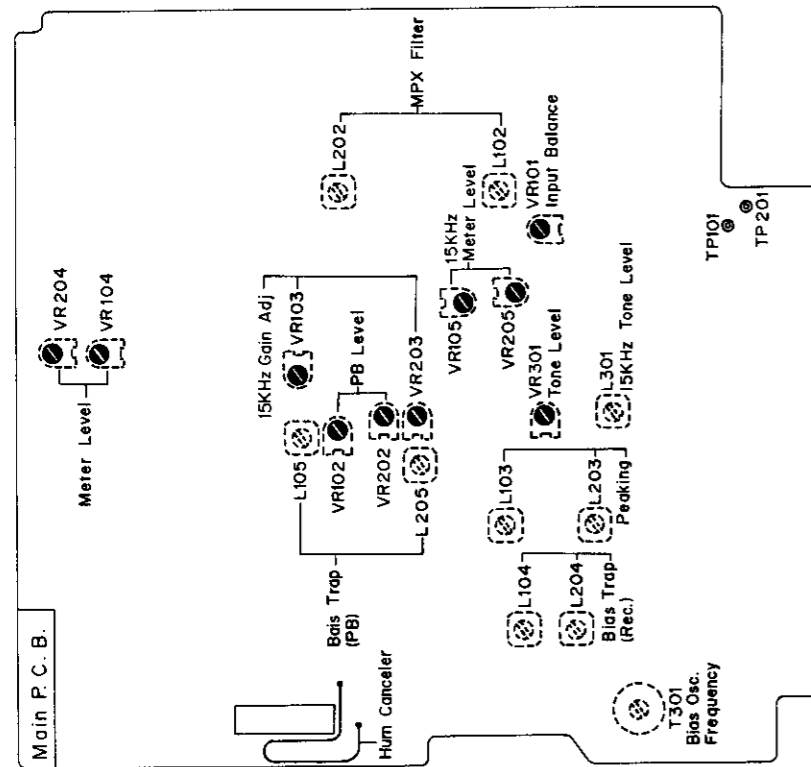

Fig. 6.2.1-A Serial Nos.: A30205002 – A30206059

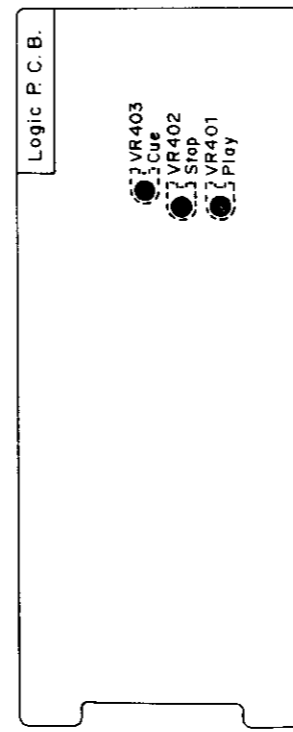
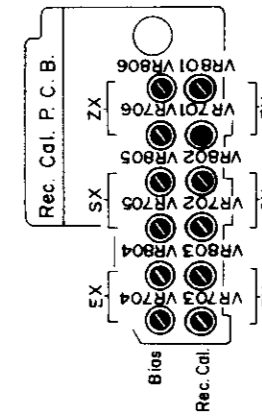
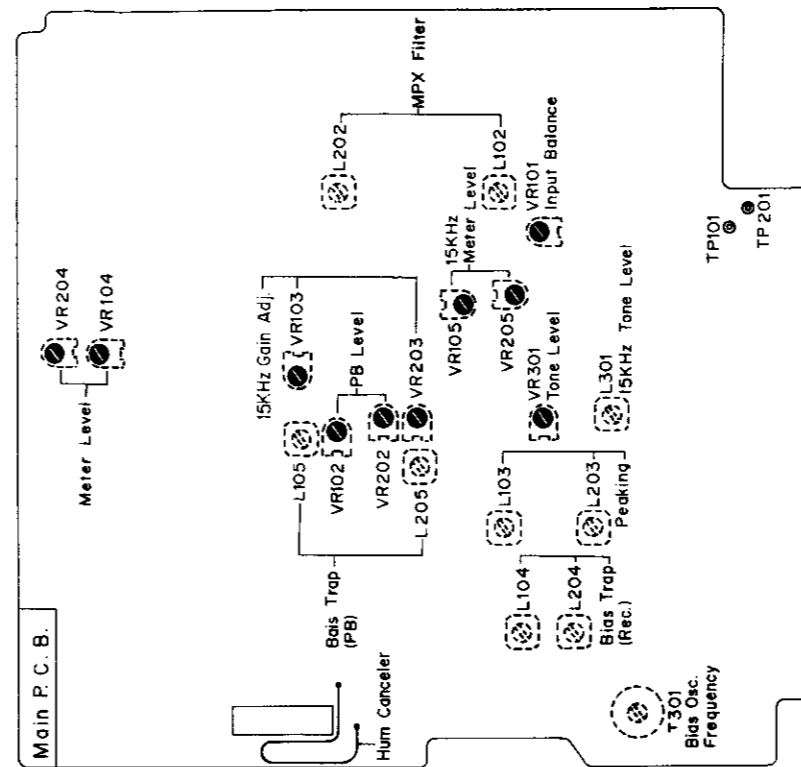

Fig. 6.2.1-B Serial Nos.: A30201001 – A30205001

6.2.2. Electrical Adjustments and Measurements

(1) Adjustment and Measurement Instructions

Note: Electrical adjustment should be performed after mechanical adjustment is completed.

STEP	ITEM	SIGNAL SOURCE	OUTPUT CONNECTION	MODE	ADJUSTMENT	REMARKS
1	Tape Speed	3 kHz Speed and Wow/Flutter Tape (DA09006A)	Frequency Counter to OUTPUT Jacks	Playback	Capstan Motor Governor P.C.B. VR501	Adjust VR501 to obtain 3 kHz \pm 0.5%. (VR501 is incorporated in the Motor.)
2	Tone Calibration	Test Tone 400 Hz and 15 kHz	VTVM to TP101, TP201 on the Main P.C.B.	Test Tone SW – 400/15 k	Main P.C.B. VR301, VR101, L301	<ol style="list-style-type: none"> Set the Test Tone Switch to 400 Hz. Turn output level control fully clockwise (maximum position). Adjust VR301 to obtain 100 mV \pm 0.2 dB on the VTVM at TP201 (output will be 1 V (0 dB)). Adjust VR101 to obtain the same level as Right channel on the VTVM at TP101. Set the Test Tone Switch to 15 kHz. Adjust L301 to obtain 10 mV \pm 0.5 dB on the VTVM. (output will be -20 dB against the level at 400 Hz).
3	Meter Level (400 Hz 0 dB)	400 Hz to INPUT Jacks	VTVM to TP101, TP201 on the Main P.C.B.	Record, Pause Tone SW – OFF	Main P.C.B. VR104, VR204	<ol style="list-style-type: none"> Feed in 400 Hz (0 dB) and adjust record level controls to obtain 100 mV \pm 0.2 dB on the VTVM. Turn output level control fully clockwise (maximum position). Adjust VR104 (VR204) to obtain 0 dB on the level meters (output will be 1 V (0 dB)). Decrease input level by 10 dB/20 dB then short or open R160 (R260) and/or R161 (R261) to obtain minimum deviation from -10 dB/-20 dB on the level meters. (Perform at -10 dB and -20 dB.) Again increase input level so that output will become 100 mV, then re-adjust VR104 (VR204) to obtain 0 dB on the level meters.
4	Meter Level 15 kHz	15 kHz to Pin No. 5, 3 of IC304 or 15 kHz PB Frequency Response Tape (DA09002A)	VTVM to CN7-3 and CN7-1 on the Main P.C.B.	Tone SW – 15 kHz or Playback Tape SW – SX Eq. SW – 70 μ s Tone SW – OFF/15 kHz	Main P.C.B. VR103, VR203	<ol style="list-style-type: none"> Set the Tone Switch to 15 kHz. Feed in 15 kHz (30 mV) to pin No. 5 (3) of IC304. Adjust VR103 (VR203) to obtain 20 dB gain at CN7-3 (CN7-1) on the VTVM. <p>or</p> <ol style="list-style-type: none"> Set the Tone Switch to Off. Load the 15 kHz PB frequency response tape (DA09002A), then play it back. Set the Tone Switch to 15 kHz, then adjust VR103 (VR203) to obtain 20 dB higher gain on the VTVM against the level at Tone Switch Off. <p>Note: Output of CN7-3 (CN7-1) is approx. 400 – 500 mV at 0 dB level.</p>

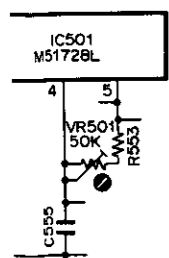

Fig. 6.2.2
1. Tape Speed

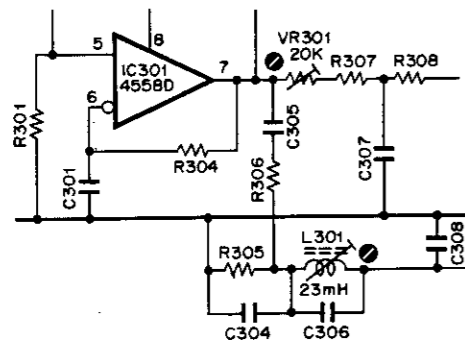

Fig. 6.2.3
2. Tone Calibration

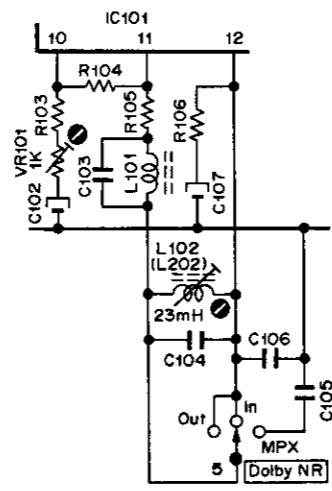

Fig. 6.2.4
2. Tone Calibration

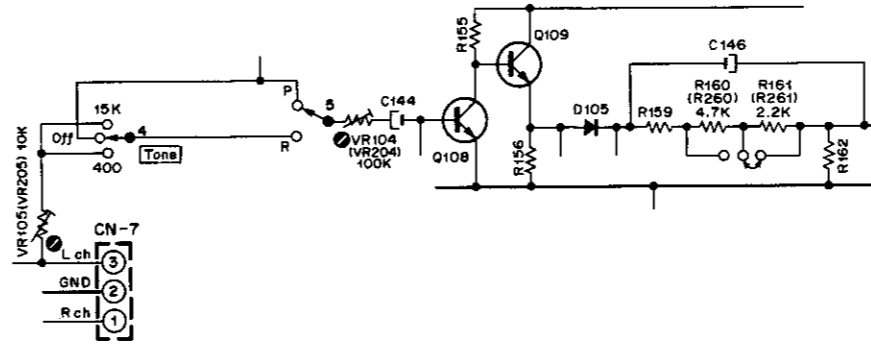

Fig. 6.2.5
3. Meter Level (400 Hz)

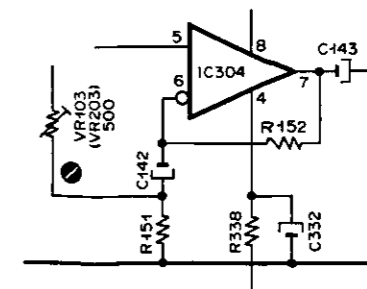

Fig. 6.2.6
4. Meter Level (15 kHz)

STEP	ITEM	SIGNAL SOURCE	OUTPUT CONNECTION	MODE	ADJUSTMENT	REMARKS
5	MPX Filter	19 kHz \pm 100 Hz to INPUT Jacks	VTVM to OUTPUT Jacks	Test Tone SW – OFF Dolby NR SW – OUT, IN/MPX	Main P.C.B. L102, L202	1. Turn output level control fully clockwise (maximum position). 2. Adjust input level control to obtain 1 V on the VTVM. 3. Set the Dolby NR Switch to IN/MPX position, then adjust L102 (L202) to obtain minimum reading on the VTVM (minimum reading will be less than -30 dB).
6	Playback Head Track Alignment	1 kHz Track Alignment Tape (DA09007A)	VTVM to OUTPUT Jacks	Playback Test Tone SW – OFF Eq. SW – 70 μ s Dolby NR SW – OUT	Playback Head Height Adj. Screw	Adjust the Playback Head Height Adj. Screw to obtain minimum reading of both L and R channels on the VTVM. See "Playback Head Height Adjustment and Azimuth Alignment" in item 5.7.
7	Playback Head Azimuth Alignment	15 kHz Azimuth Tape (DA09004A)	VTVM to OUTPUT Jacks	Same as above	Playback Head Azimuth Alignment Screw	Adjust the Playback Head Azimuth Alignment Screw to obtain maximum reading of both L and R channels on the VTVM. See "Playback Head Height Adjustment and Azimuth Alignment" in item 5.7. Note: Repeat steps 6 and 7 one or two times to obtain optimum performance.
8	Playback Level	400 Hz Level Tape (DA09005A)	VTVM to TP101, TP201	Same as above	Main P.C.B. VR102, VR202	Adjust VR102 (VR202) to obtain 100 mV on the VTVM or 0 dB on the level meters.
9	Adjustment of Hum Canceler	Blank Tape	VTVM to OUTPUT Jacks	Playback Eq. SW – 70 μ s Dolby NR SW – IN/MPX	Main P.C.B. Hum Canceler (Jumper wire)	Adjust Hum Canceler to obtain minimum reading of R channel on the VTVM.
10	Playback Frequency Response	400 Hz Level Tape (DA09005A) 10 kHz PB Frequency Response Tape (DA09003A) 15 kHz PB Frequency Response Tape (DA09002A) 20 kHz PB Frequency Response Tape (DA09001A)	VTVM to OUTPUT Jacks	Playback Tape SW – SX Eq. SW – 70 μ s Dolby NR SW – OUT	Main P.C.B. R146, R246 R147, R247	1. Load the 400 Hz level tape and play it back. Adjust the output level control to a certain level (example 0 dB). 2. Load the 10 kHz, 15 kHz and 20 kHz PB frequency response tapes and adjust the playback head azimuth to give maximum levels on the VTVM with each tape. Short R146 (R246) and/or R147 (R247) to obtain the following level against 400 Hz level tape. Refer to Fig. 6.2.8. 10 kHz: -20 dB -1 dB to +2 dB 15 kHz: -20 dB -1 dB to +3 dB 20 kHz: -20 dB -1 dB to +4 dB 3. Conduct step 6 "Playback Head Azimuth Alignment". 4. If above is not sufficient, refer to "Playback Frequency Response Adjustment" in item 6.2.2-(2).
11	Bias Oscillation Frequency and Erase Current	Connect an additional 0.1 Ω resistor in series to the Erase Head	VTVM and Frequency Counter across the additional 0.1 Ω resistor	Record, Pause Tape SW – ZX Eq. SW – 70 μ s Dolby NR SW – OUT	Main P.C.B. T301 R319, R341	1. Adjust T301 to obtain 105 kHz on the frequency counter. 2. Check the erase current by the VTVM. Erase current will be in a range of 310 mA to 400 mA (typically approx. 350 mA). If erase current is not sufficient, increase it by shorting R319 or R341. 3. After completion of the erase current adjustment, re-check the bias oscillation frequency.

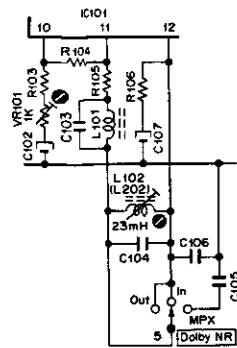

Fig. 6.2.7
5. MPX Filter

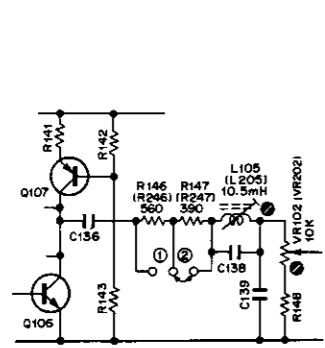

Fig. 6.2.8
8. Playback Level
14. Bias Trap (Playback Amp.)

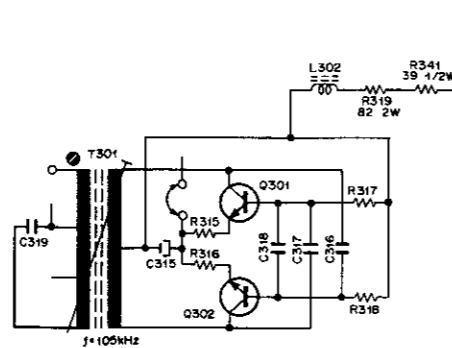

Fig. 6.2.9
11. Bias Oscillation Frequency
and Erase Current

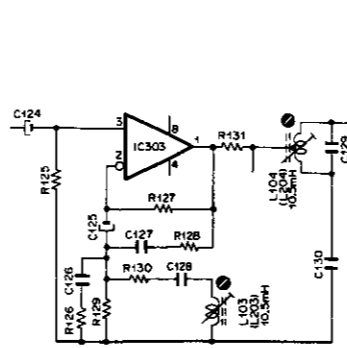

Fig. 6.2.10
12. Record Amplifier Equalizer
13. Bias Trap (Record Amp.)
18. Record/Playback Frequency Response

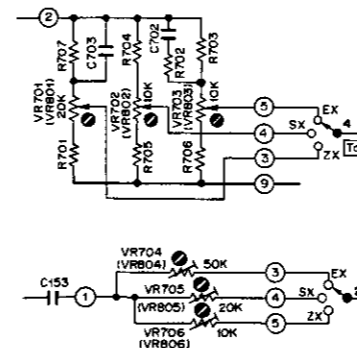

Fig. 6.2.11
17. Record Level and
Recording Bias Current

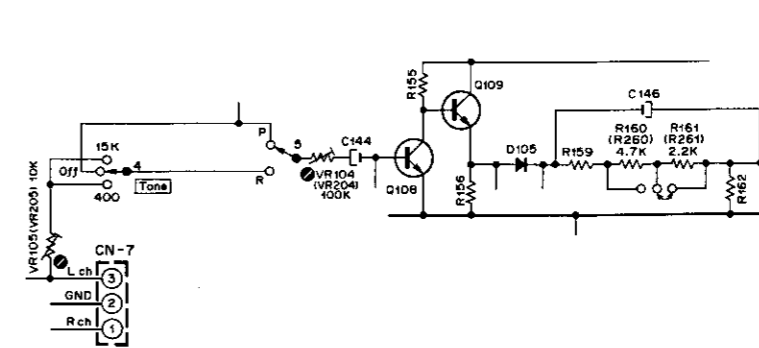

Fig. 6.2.12
19. Monitor Amplifier

STEP	ITEM	SIGNAL SOURCE	OUTPUT CONNECTION	MODE	ADJUSTMENT	REMARKS
12	Record Amplifier Equalizer	23 kHz (-20 dB) to INPUT Jacks	VTVM to Main P.C.B. CN5-1, CN5-3	Record, Pause Tape SW - ZX Eq. SW - 70 μs Dolby NR SW - OUT	Main P.C.B. L103, L203	1. Remove the bias-cut-jumper from the dip side of the main P.C.B. 2. Adjust L103 (L203) to obtain peak reading at 23 kHz on the VTVM. 3. Re-solder the bias-cut-jumper.
13	Bias Trap (Record Amp.)	Remove Input Signals	Same as above	Same as above	Main P.C.B. L104, L204	Adjust L104 (L204) to obtain maximum reading on the VTVM.
14	Bias Trap (Playback Amp.)	Same as above	VTVM to Main P.C.B. CN7-3, CN7-1	Record, Pause Tape SW - ZX Eq. SW - 70 μs Dolby NR SW - OUT	Main P.C.B. L105, L205	Adjust L105 (L205) to obtain minimum reading on the VTVM.
15	Record Head Height Adjustment	Test Tone 400 Hz	Same as above	Record, Playback Tape SW - SX Eq. SW - 70 μs Dolby NR SW - OUT	Record Head Height Adj. Screw	Adjust the Record Head Height Adj. Screw to obtain maximum reading of L and R channels on the VTVM. See "Record Head Height Adjustment and Azimuth Alignment" in item 5.7.
16	Record Head Azimuth Alignment	Test Tone 15 kHz	Same as above	Same as above	Record Head Azimuth Alignment Screw	Adjust the Record Head Azimuth Alignment Screw to obtain maximum reading of L and R channels on the VTVM. See "Record Head Height Adjustment and Azimuth Alignment" in item 5.7.
17	Record Level Calibration and Recording Bias Current Adjustment	Test Tone 400 Hz and 15 kHz or 400 Hz and 15 kHz to INPUT Jacks	Same as above	Record, Playback Tape SW - EX/SX/ZX Eq. SW - 120 μs (EX) 70 μs (SX/ZX) Tone SW - 400 Hz/15 kHz Dolby NR SW - OUT	Rec. Cal. P.C.B. VR701, VR702, VR703, VR801, VR802, VR803, VR704, VR705, VR706, VR804, VR805, VR806	1. Set the Tone Switch to 400 Hz. 2. Record signals on the reference EXII tape (DA09021A), reference SX tape (DA09025A), or reference ZX tape (DA09037A), then play it back. 3. Adjust Rec. Cal. VR703 (VR803) (for EXII), VR702 (VR802) (for SX) and VR701 (VR801) (for ZX) to the center their positions. 4. Adjust Bias VR704 (VR804) (for EXII), VR705 (VR805) (for SX) and VR706 (VR806) (for ZX) to obtain maximum reading on the VTVM. 5. Set the Tone Switch to 15 kHz. 6. Adjust Bias VR704 (VR804), VR705 (VR805) and VR706 (VR806) to obtain the same readings as source monitor levels on the VTVM. 7. Set the Tone Switch to 400 Hz. 8. Adjust Rec. Cal. VR703 (VR803), VR702 (VR802) and VR701 (VR801) to obtain 0 dB on the level meters. 9. Repeat 5 through 8 as above two or three times to obtain optimum performance. 10. Check whether Total Harmonic Distortion (T.H.D.) is less than 1.0% for EXII and SX tapes, and 0.8% for ZX tape.
18	Record/Playback Frequency Response	400 Hz (0 dB) and 20 Hz to 20 kHz (-20 dB) to INPUT Jacks	Same as above	Record, Playback Tape SW - EX/SX/ZX Eq. SW - 120 μs (EX) 70 μs (SX/ZX) Tone SW - OUT Dolby NR SW - OUT	Main P.C.B. L103, L203	1. Feed in 400 Hz (0 dB) and adjust record level controls to obtain 0 dB on the level meters. 2. Switch the Generator output level to -20 dB, then record and play it back. 3. Feed in 20 Hz to 20 kHz (-20 dB), and check to insure if the output levels are within -20 dB ± 3 dB. 4. If above is not sufficient, adjust L103 (L203) to obtain approx. -20 dB on the VTVM. 5. Conduct step 17 "Record Level Calibration and Recording Bias Current Adjustment". 6. If above is not sufficient, precise re-adjustment of step 10 "Playback Frequency Response", replacement of Playback Head or Record Head, or check on item 5.9 "Tape Travelling Adjustment" will be required.
19	Adjustment of Monitor Amplifier	Test Tone 400 Hz and 15 kHz		Record and Playback Tone SW - 400/15 k Tape SW - SX Eq. SW - 70 μs Dolby NR SW - OUT	Main P.C.B. VR105, VR205	1. Set the Tone Switch to 400 Hz. 2. Load the reference SX tape (DA09025A), then record and play it back. Adjust VR105 (VR205) to obtain 0 dB on the level meters. 3. Set the Tone Switch to 15 kHz, then check to insure that the level meters flutter at 0 dB.

STEP	ITEM	SIGNAL SOURCE	OUTPUT CONNECTION	MODE	ADJUSTMENT	REMARKS
20	Crosstalk	1 kHz to INPUT Jacks	1 kHz Band Pass Filter, VTVM to OUTPUT Jacks	Record and Playback Tape SW – ZX Eq. SW – 70 μ s Dolby NR SW – OUT		<ol style="list-style-type: none"> 1. Erase the tape with bulk eraser. 2. Adjust record level controls to obtain 0 dB on the level meters, and record the signals on the reference tape. 3. Turn the cassette tape the other way round and play it back. 4. Measure the difference between 2 and 3.
21	Channel Separation	1 kHz to INPUT Jacks	Same as above	Same as above		<ol style="list-style-type: none"> 1. Erase the tape with bulk eraser. 2. Adjust Lch (Rch) record level control to obtain 0 dB on the level meter, and close Rch (Lch) record level control. 3. Record and play it back, then measure the Rch (Lch) level.
22	Erasure	1 kHz to INPUT Jacks	Same as above	Same as above		<ol style="list-style-type: none"> 1. Erase the tape with bulk eraser. 2. Adjust record level controls to obtain 0 dB on the level meters, and record the signals on the reference tape. 3. Rewind the tape then close record level controls. 4. Record and play it back, then measure the difference between 2 and 3.
23	Signal to Noise Ratio	400 Hz to INPUT Jacks	VTVM and Distortion Meter to OUTPUT Jacks	Record and Playback Tape SW – ZX Eq. SW – 70 μ s Dolby NR SW – IN/MPX		<ol style="list-style-type: none"> 1. Feed in 400 Hz and record, and play it back. 2. Adjust the record level controls to obtain 3% total harmonic distortion in playback mode. 3. Close the record level controls then record. 4. After rewind, play back and check the output level difference between 2 and 3. <p>Note: The filter of IHF-A curve shall be used in the measurements.</p>
24	Total Harmonic Distortion	400 Hz to INPUT Jacks	Distortion Meter to OUTPUT Jacks	Record and Playback Tape SW – EX/SX/ZX Eq. SW – 120 μ s (EX) 70 μ s (SX/ZX) Dolby NR SW – OUT		<ol style="list-style-type: none"> 1. Adjust record level controls to obtain 0 dB on the level meters. 2. Record and play it back. 3. Read the distortion meter and check to insure that the distortion is less than 1.0% for EXII and SX tapes, and 0.8% for ZX tape.
25	Wow/Flutter	3 kHz Speed and Wow/Flutter Tape (DA09006A)	Wow/Flutter Meter to OUTPUT Jacks	Playback Monitor SW – Tape Eq. SW – 70 μ s		Playback and read the wow/flutter meter.

(2) Frequency Response Adjustment

Same as the current type, please refer to item 6.1.2-
(2) on page 50.

(3) Dolby NR Circuit Check

Same as the current type, please refer to item 6.1.2-
(3) on page 50.

7. MOUNTING DIAGRAMS AND PARTS LIST

Note: Mounting diagram shows a dip side view of the printed circuit board.

7.1. Control Switch P.C.B. Ass'y

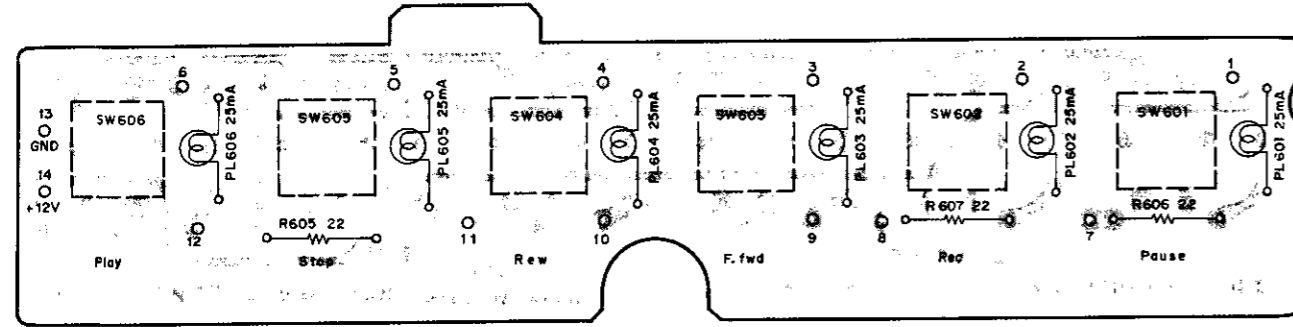

Fig. 7.1

7.2. Volume P.C.B. Ass'y

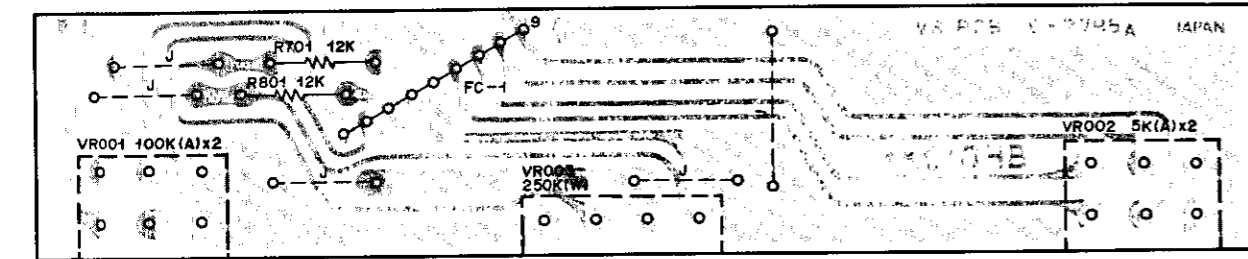

Fig. 7.2

7.3. DIN-Pin P.C.B. Ass'y

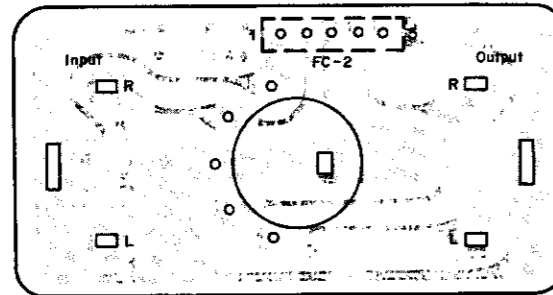

Fig. 7.3

Schematic Ref. No.	Part No.	Description	Schematic Ref. No.	Part No.	Description
	BA03976A	Control Switch P.C.B. Ass'y		BA04013A	Volume P.C.B. Ass'y
R605,606	OB07798A	Control Switch P.C.B.	VR001	OB07795A	Volume P.C.B.
607	OB09049A	Fail Safe Type Resistor 22 RBF25S J	VR002	OB07231A	Volume 100K (A) x 2
PL601,602	OB08552A	Lamp 12V 25mA	VR003	OB07259A	Volume 5K (A) x 2
603,604			R701,801	OB07255A	Volume 250K (W)
605,606			FC1	OB05771A	Carbon Resistor 12K ERD-25T J
SW601,602	OB07254A	Switch EVQ-P1R04K		OB05229A	Flat Cable D
603,604				OJ03973B	Volume Holder A301 (1 pce.)
605,606				BA04031A	DIN-Pin P.C.B. Ass'y
	OB08567B	Lamp Holder (6 pcs.)	FC2	OB07816A	DIN-Pin Jack P.C.B.
				OB05226A	Flat Cable (1 pce.)
				OB08097A	Jack Unit (1 pce.)
				OE00037A	Earch Lug B-5 (1 pce.)

7.4. Shut-off P.C.B. Ass'y

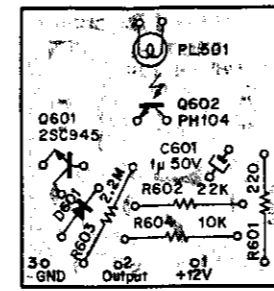

Fig. 7.4.1

Serial No.: A30206790 -

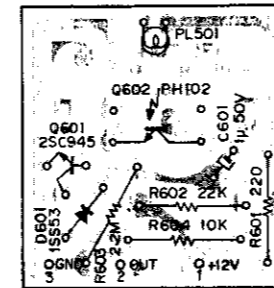

Fig. 7.4.2

Serial Nos.: A30201001 - A30206789

7.5. Record Cal. P.C.B. Ass'y

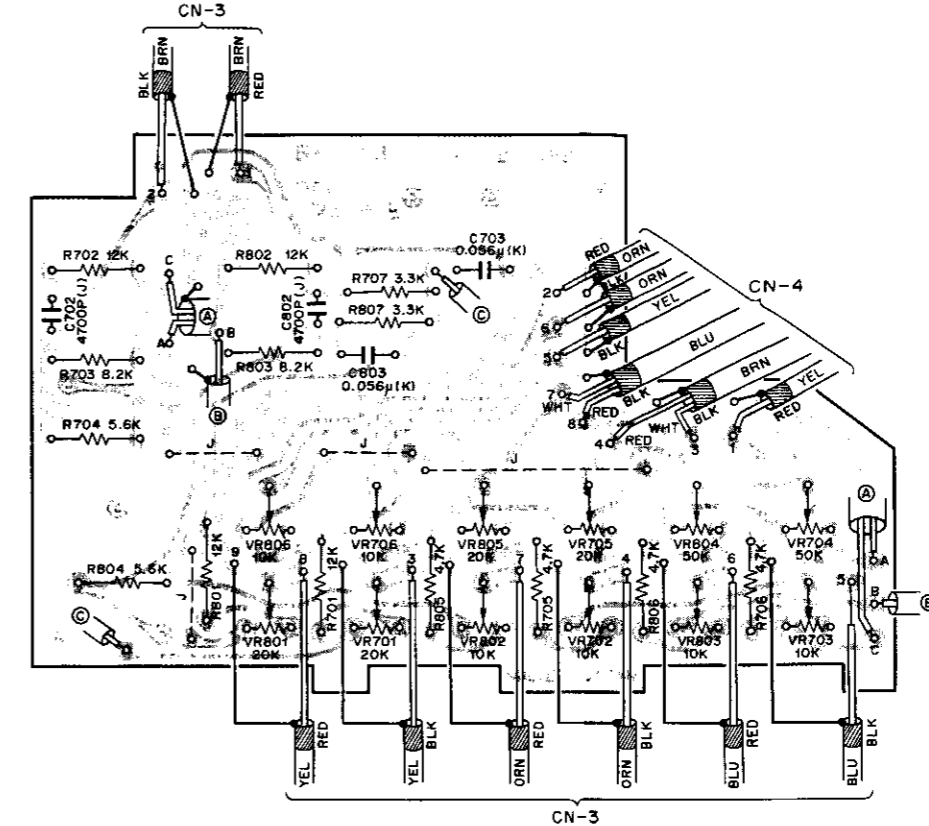

Fig. 7.5

Schematic Ref. No.	Part No.	Description	Schematic Ref. No.	Part No.	Description
	BA04076A	Shut-off Sensor P.C.B. Ass'y Serial No. A30206790 -		BA04014A	Record Calibration P.C.B. Ass'y
Q601	OB07800B	Shut-off Sensor P.C.B.	VR701,705	OB07813C	Record Calibration P.C.B.
Q602	OB06228A	Photo Transistor PH104	801,805	OB07270A	Semi-fixed Volume 20K
D601	OB06181A	Silicon Diode 1S553	VR702,703	OB07256A	Semi-fixed Volume 10K
R601	OB01933A	Carbon Resistor 220 ERD-25T J	706,802		
R602	OB05615A	Carbon Resistor 22K ERD-25T J	803,806		
R603	OB05671A	Carbon Resistor 2.2M ERD-25T J	VR704,804	OB07269A	Semi-fixed Volume 50K
R604	OB01888A	Carbon Resistor 10K ERD-25T J	R701,702	OB05771A	Carbon Resistor 12K ERD-25T J
C601	OB01405A	Electrolytic Capacitor 1μ 50V	801,802		
PL501	OB08552A	Lamp 12V 25mA	R703,803	OB01856A	Carbon Resistor 8.2K ERD-25T J
	BA03975A	Shut-off Sensor P.C.B. Ass'y Serial Nos.: A30201001 - A30206789	R704,804	OB01887A	Carbon Resistor 5.6K ERD-25T J
Q601	OB07800B	Shut-off Sensor P.C.B.	R705,706	OB01846A	Carbon Resistor 4.7K ERD-25T J
Q602	OB01872A	Transistor 2SC945	805,806		
D601	OB06182A	Photo Transistor PH102	R707,807	OB01681A	Carbon Resistor 3.3K ERD-25T J
R601	OB06181A	Silicon Diode 1S553	C702,802	OB05652A	Mylar Capacitor 4700P 50V J
R602	OB01933A	Carbon Resistor 220 ERD-25T J	C703,803	OB09274A	Ceramic Capacitor 0.056μ 25V K
R603	OB05615A	Carbon Resistor 22K ERD-25T J	CN3	OB08617B	9P-H Connector A302
R604	OB05671A	Carbon Resistor 2.2M ERD-25T J	CN4	OB08616B	8P-H Connector A302
C601	OB01888A	Carbon Resistor 10K ERD-25T J			
PL501	OB01405A	Electrolytic Capacitor 1μ 50V			
	OB08552A	Lamp 12V 25mA			
	OC08108A	Photo Transistor Terminal (2 pcs.)			

7.6. Main P.C.B. Ass'y

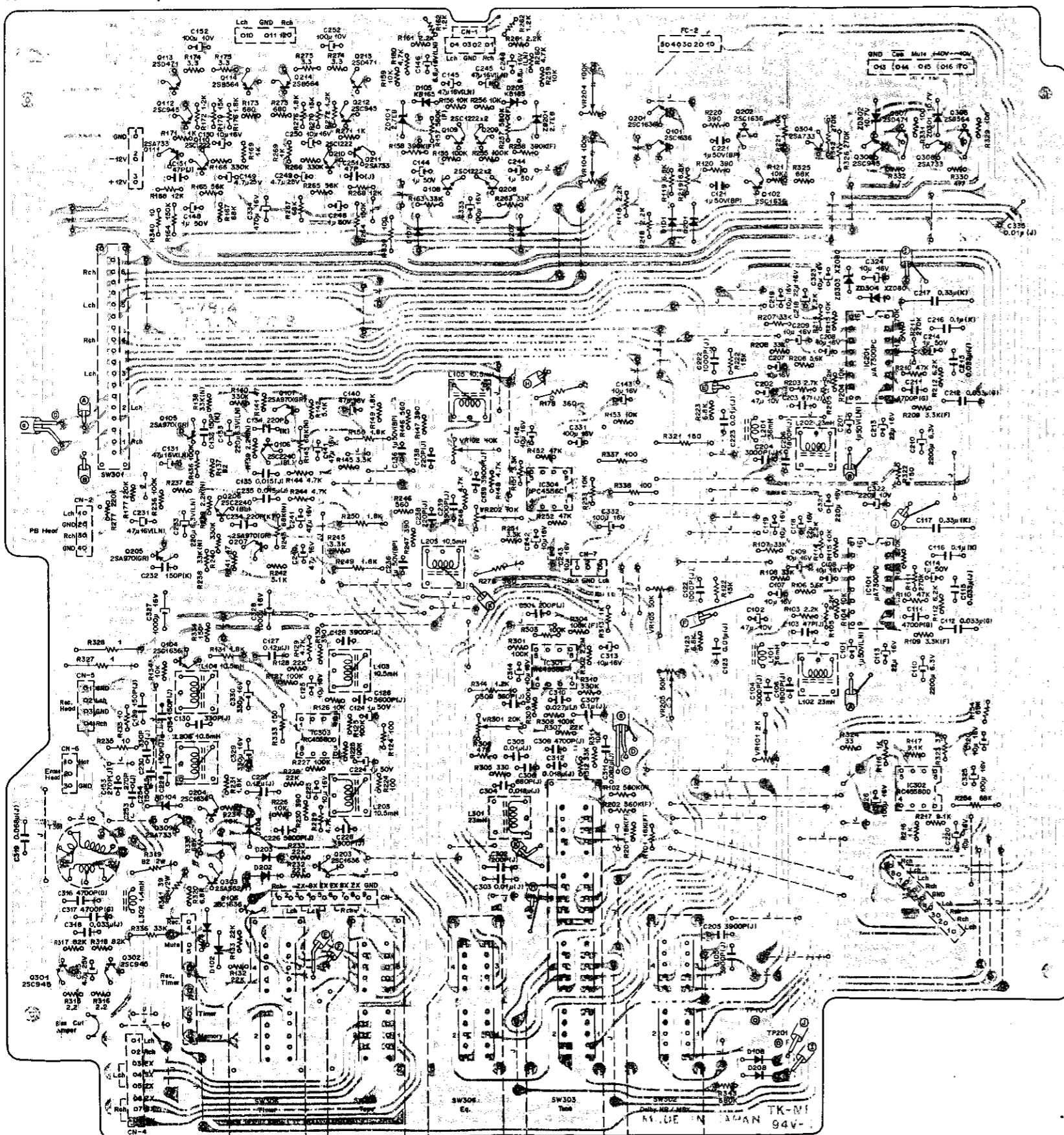

Fig. 7.6.1 Serial No.: A30206060 -

Schematic Ref. No.	Part No.	Description	
	BA04015C	Main P.C.B. Ass'y Serial No.: A30206060 -	
		- PB Eq. Amp. -	
Q105,107 205,207	0B06180A	Transistor	2SA970 (GR)
Q106,206	0B06142A	Transistor	2SC2240 (BL)
L105,205	0B00068A	Trap Coil	10.5mH
VR102,202	0B07236A	Semi-fixed Volume	10K
R136,236	0B01920A	Carbon Resistor	100K ERD-25V J
R137,237	0B05503A	Carbon Resistor	82 ERD-25V J
R138,238	0B09239A	Carbon Resistor	33K ERD-25VS J (Noiseless)
R139,239	0B09244A	Carbon Resistor	2.2K ERD-25VS J (Noiseless)
R140,240	0B01921A	Carbon Resistor	330K ERD-25V J
R141,241	0B05569A	Carbon Resistor	47 ERD-25V J
R142,242	0B09186A	Carbon Resistor	5.1K ERD-25V J
R143,243	0B09268A	Carbon Resistor	68K ERD-25VS J (Noiseless)
R144,244 148,248	0B01795A	Carbon Resistor	4.7K ERD-25V J
R145,245	0B01793A	Carbon Resistor	3.3K ERD-25V J
R146,246	0B05678A	Carbon Resistor	560 ERD-25V J
R147,247	0B05688A	Carbon Resistor	390 ERD-25V J
R149	0B01830A	Carbon Resistor	1.8K ERD-25V J
R150,249 250	0B05614A	Carbon Resistor	1.8K ERD-25T J
R177,277	0B05596A	Carbon Resistor	220K ERD-25V J
C131,231	0B09218A	Electrolytic Capacitor	47μ 16V (LN)
C132,232	0B09281A	Ceramic Capacitor	150P 50V K
C133,233	0B09151A	Electrolytic Capacitor	220μ 6.3V (LN)
C134,234	0B09283A	Ceramic Capacitor	220P 50V K
C135,235	0B05557A	Mylar Capacitor	0.015μ 50V J
C136,236	0B09187A	Electrolytic Capacitor	1μ 50V (BP)
C138,238	0B09247A	Mica Capacitor	220P 50V J
C139,239	0B01804A	Mylar Capacitor	3900P 50V J
C140,141 240,241	0B01403A	Electrolytic Capacitor	47μ 16V
		- Line Amp. -	
IC302	0B06146A	IC	RC4558DD
Q101,102 201,202	0B06070A	Transistor	2SC1636
Q304,306	0B06013A	Transistor	2SA733
Q305	0B06069A	Transistor	2SB564
Q307	0B06066A	Transistor	2SD471
Q308	0B01872A	Transistor	2SC945
D101,201	0B06181A	Silicon Diode	1SS53
ZD301,302	0B06199A	Zener Diode	10 7V
R116,216	0B01781A	Carbon Resistor	1K ERD-25V J
R117,217	0B09184A	Carbon Resistor	9.1K ERD-25V J
R118,218	0B05566A	Carbon Resistor	2.2K ERD-25V J
R119,219	0B01877A	Carbon Resistor	6.8K ERD-25V J
R120,220	0B05688A	Carbon Resistor	390 ERD-25V J
R121,221	0B01833A	Carbon Resistor	10K ERD-25V J
R323,324	0B09210A	Fail Safe Type Resistor	33 RDF25S J
R325	0B01902A	Carbon Resistor	68K ERD-25V J
R326,342	0B05600A	Carbon Resistor	270K ERD-25V J
R327,328	0B09214A	Fail Safe Type Resistor	1 RDF25S J

Schematic Ref. No.	Part No.	Description	Schematic Ref. No.	Part No.	Description	Schematic Ref. No.	Part No.	Description	Schematic Ref. No.	Part No.	Description
R329,331	OB09215A	Fail Safe Type Resistor 100 RDF25S J	R130,230	OB05688A	Carbon Resistor 390 ERD-25V J	-- Headphone Amp. --			R203	OB01782A	Carbon Resistor 2.7K ERD-25V J
R330,332	OB09243A	Fail Safe Type Resistor 4.7 RDF50S J	R131,231	OB01830A	Carbon Resistor 1.8K ERD-25V J	Q110,210	OB06062A	Transistor 2SC1222	R321,322	OB09213A	Fail Safe Type Resistor 150 RDF25S J
C120,220	OB01412A	Electrolytic Capacitor 10μ 16V	R135,235	OB05663A	Carbon Resistor 10 ERD-25V J	Q111,211	OB06013A	Transistor 2SA733	R343	OB05597A	Carbon Resistor 680K ERD-25V J
C121,221	OB09187A	Electrolytic Capacitor 1μ 50V (BP)	R333,334	OB09213A	Fail Safe Type Resistor 150 RDF25S J	Q112,212	OB01872A	Transistor 2SC945	C101,201	OB09223A	Electrolytic Capacitor 1μ 50V (LN)
C325,326	OB01400A	Electrolytic Capacitor 100μ 16V	R335	OB01902A	Carbon Resistor 68K ERD-25V J	Q113,213	OB06066A	Transistor 2SD471	C102,202	OB01836A	Electrolytic Capacitor 47μ 10V
C327,328	OB01397A	Electrolytic Capacitor 1000μ 16V	R336	OB01879A	Carbon Resistor 33K ERD-25V J	Q114,214	OB06069A	Transistor 2SB564	C103,203	OB09242A	Mica Capacitor 47P 50V J
C335	OB05681A	Mylar Capacitor 0.01μ 50V J	C122,222	OB05550A	Mylar Capacitor 1000P 50V J	R164,264	OB05593A	Carbon Resistor 150K ERD-25V J	C104,204	OB09262A	PP Capacitor 3000P 50V J
-- Tone Osc. --			C123,223	OB05681A	Mylar Capacitor 0.01μ 50V J	R165,265	OB05563A	Carbon Resistor 56K ERD-25V J	C105,205	OB01804A	Mylar Capacitor 3900P 50V J
IC301	OB06124B	IC RC4558D	C124,224	OB01405A	Electrolytic Capacitor 1μ 50V	R166,266	OB01921A	Carbon Resistor 330K ERD-25V J	C106,206	OB01913A	Mylar Capacitor 1800P 50V J
L301	OB03563A	19K Coil 23mH	C125,225	OB01412A	Electrolytic Capacitor 10μ 16V	R167,267	OB01902A	Carbon Resistor 68K ERD-25V J	C107,108	OB01412A	Electrolytic Capacitor 10μ 16V
VR301	OB09093A	Semi-fixed Volume 20K	C126,226	OB05659A	Mylar Capacitor 5600P 50V J	R168,268	OB05650A	Carbon Resistor 12K ERD-25V J	109,119		
R101,201	OB09205A	Metal Film Resistor 18K SN15K2E F	C127,227	OB05909A	Mylar Capacitor 0.12μ 50V J	R169,171	OB01781A	Carbon Resistor 1K ERD-25V J	207,208		
R102,202	OB09206A	Metal Film Resistor 560K SN15K2E F	C128,228	OB01804A	Mylar Capacitor 3900P 50V J	269,271			209,219		
R301,303	OB01920A	Carbon Resistor 100K ERD-25V J	C129,229	OB09246A	Mica Capacitor 150P 50V J	R170,270	OB05591A	Carbon Resistor 15K ERD-25V J	323,324		
308,309			C154,254	OB09322A	PP Capacitor 330P 100V J	R172,272	OB05565A	Carbon Resistor 1.2K ERD-25V J	C110,210	OB09257A	Electrolytic Capacitor 2200μ 6.3V
R302	OB05672A	Carbon Resistor 2.2M ERD-25V J	C329,330	OB01502A	Electrolytic Capacitor 300μ 16V	R173,273	OB05559A	Carbon Resistor 680 ERD-25V J	C111,211	OB09191A	PP Capacitor 4700P 100V G
R304	OB09269A	Metal Film Resistor 100K ERD-25VK F	-- Bias Osc. --			R174,175	OB05779A	Carbon Resistor 3.3 ERD-25V J	C112,212	OB09240A	PP Capacitor 0.033μ 100V G
R305	OB01789A	Carbon Resistor 330 ERD-25V J	Q301,302	OB01872A	Transistor 2SC945	R176,276	OB01830A	Carbon Resistor 1.8K ERD-25V J	C113,118	OB01862A	Electrolytic Capacitor 22μ 16V
R306	OB05562A	Carbon Resistor 47K ERD-25V J	Q303	OB06202A	Transistor 2SA562 (Y)	R340	OB09216A	Fail Safe Type Resistor 10 RDF25S J	C114,214	OB01405A	Electrolytic Capacitor 1μ 50V
R307	OB05661A	Carbon Resistor 22K ERD-25V J	T301	OB06613A	Osc. Coil 1.4mH	C148,248	OB01405A	Electrolytic Capacitor 1μ 50V	C115,215	OB05583A	Mylar Capacitor 0.033μ 50V J
R310	OB01921A	Carbon Resistor 330K ERD-25V J	L302	OB03861A	Inductor 1.4mH	C149,249	OB01402A	Electrolytic Capacitor 4.7μ 25V	C116,216	OB01603A	Mylar Capacitor 0.1μ 50V K
R311	OB01833A	Carbon Resistor 10K ERD-25V J	R315,316	OB09212A	Fail Safe Type Resistor 2.2 RDF25S J	C150,250	OB01412A	Electrolytic Capacitor 10μ 16V	C117,217	OB01602A	Mylar Capacitor 0.33μ 50V K
R312	OB01879A	Carbon Resistor 33K ERD-25V J	R317,318	OB01564A	Carbon Resistor 82K ERD-25V J	C151,251	OB09280A	Ceramic Capacitor 47P 50V J	C321,322	OB01398A	Electrolytic Capacitor 220μ 16V
R313	OB01857A	Carbon Resistor 1K ERD-25T J	R319	OB09295A	Fail Safe Type Resistor 82 RSF-2B J	C152,252	OB05885A	Electrolytic Capacitor 100μ 10V	-- Miscellaneous --		
R314	OB05623A	Carbon Resistor 1.2K ERD-25T J	R320	OB01877A	Carbon Resistor 6.8K ERD-25V J	C334	OB01392A	Electrolytic Capacitor 470μ 16V	OB07814E	Main P.C.B. A302	
C301	OB09275A	Mica Capacitor 200P 50V J	R341	OB09296A	Fail Safe Type Resistor 39 RSF-½B J	-- Monitor Amp. --			OB07267A	Record Switch A302	
C302	OB05687A	Mylar Capacitor 1200P 50V J	C153,253	OB09284A	Ceramic Capacitor 270P 50V J	IC304	OB06234A	IC μPC4556C	OB07264A	Rotary Slide Switch C	
C303,305	OB05681A	Mylar Capacitor 0.01μ 50V J	C315	OB01402A	Electrolytic Capacitor 4.7μ 25V	VR105,205	OB07237A	Semi-fixed Volume 50K	SW302,305	OB07266A	Rotary Slide Switch E
C304,312	OB05832A	Mylar Capacitor 0.018μ 50V J	C316,317	OB09191A	PP Capacitor 4700P 100V G	R151,251	OB01793A	Carbon Resistor 3.3K ERD-25V J	SW303	OB07266A	Rotary Slide Switch E
C306	OB09235A	PP Capacitor 680P 100V J	C318	OB05583A	Mylar Capacitor 0.033μ 50V J	R152,252	OB05562A	Carbon Resistor 47K ERD-25V J	SW304	OB07262A	Rotary Slide Switch A
C307	OB01780A	Mylar Capacitor 0.1μ 50V J	C319	OB09254A	PP Capacitor 0.068μ 100V J	R153,253	OB01833A	Carbon Resistor 10K ERD-25V J	SW306	OB07263A	Rotary Slide Switch B
C308	OB05652A	Mylar Capacitor 4700P 50V J	-- Meter Amp. --			R178,278	OB09326A	Carbon Resistor 360 ERD-25T J	TP101,201	OB03924A	Gate Pin
C309	OB09323A	PP Capacitor 560P 100V J	Q108,109	OB06062A	Transistor 2SC1222	R337,338	OB09215A	Fail Safe Type Resistor 100 RDF25S J	OC08569C	Record Wire Holder (1 pce.)	
C310	OB09045A	Mylar Capacitor 0.027μ 50V J	D105,205	OB06007A	Silicon Varistor KB-165	C142,143	OB01412A	Electrolytic Capacitor 10μ 16V	OB08375A	4P-S Post (1 pce.)	
C311	OB05685A	Mylar Capacitor 0.082μ 50V J	D107,207	OB06181A	Silicon Diode 1SS53	242,243			OB08185A	3P-T Post (2 pcs.)	
C313,314	OB01412A	Electrolytic Capacitor 10μ 16V	ZD101,201	OB06191A	Zener Diode 2.7EB 2.7V	C331,332	OB01400A	Electrolytic Capacitor 100μ 16V	OB08236A	4P-T Post (2 pcs.)	
-- Rec. Amp. --			VR104,204	OB03832A	Semi-fixed Volume 100K	-- Dolby NR --			OB08334A	8P-T Post (1 pce.)	
IC303	OB06146A	IC RC4558DD	R154,254	OB01902A	Carbon Resistor 68K ERD-25V J	IC101,201	OB06175A	IC μA7300PC	OB08614A	9P-T Post (1 pce.)	
Q103,104	OB06070A	Transistor 2SC1636	R155,255	OB01920A	Carbon Resistor 100K ERD-25V J	D108,208	OB06181A	Silicon Diode 1SS53	OB08542A	Wrapping Pin 1P (1 pce.)	
Q309	OB06013A	Transistor 2SA733	R156,159	OB01833A	Carbon Resistor 10K ERD-25V J	ZD303,304	OB06090A	Zener Diode ZX080	OB08544A	Wrapping Pin 3P (2 pcs.)	
D102,103	OB06181A	Silicon Diode 1SS53	256,259			L101,201	OB03919A	Inductor 36mH	OB08545A	Wrapping Pin 4P (1 pce.)	
104,202			R157,257	OB09206A	Metal Film Resistor 560K SN15K2E F	L102,202	OB03563A	19K Coil 23mH	OB08547A	Wrapping Pin 6P (1 pce.)	
203,204			R158,258	OB09207A	Metal Film Resistor 390K SN15K2E F	VR101	OB09106A	Semi-fixed Volume 2K	OC08570A	Record Spring Holder (1 pce.)	
L103,104	OB00068A	Trap Coil 10.5mH	R160,260	OB01795A	Carbon Resistor 4.7K ERD-25V J	R103,105	OB05566A	Carbon Resistor 2.2K ERD-25V J	OC08144C	Record Spring (1 pce.)	
203,204			R161,261	OB05566A	Carbon Resistor 2.2K ERD-25V J	114,205			OE00037A	Earth Lug B-5 (1 pce.)	
R122,222	OB05591A	Carbon Resistor 15K ERD-25V J	R162,262	OB05565A	Carbon Resistor 1.2K ERD-25V J	214			OE00172A	Washer Toothed Lock 3mm (1 pce.)	
R123,223	OB01877A	Carbon Resistor 6.8K ERD-25V J	R163,263	OB01879A	Carbon Resistor 33K ERD-25V J	R104,115			OE00788A	BT Screw M2x8 Phillips Pan Head (1 pce.)	
R124,224	OB05558A	Carbon Resistor 100 ERD-25V J	R339	OB09215A	Fail Safe Type Resistor 100 RDF25S J	204,215			OE00831A	BT Screw M3x10 Phillips Pan Head (1 pce.)	
R125,127	OB01920A	Carbon Resistor 100K ERD-25V J	C144,244	OB01405A	Electrolytic Capacitor 1μ 50V	R106,206	OB05673A	Carbon Resistor 5.6K ERD-25V J			
225,227			C145,245	OB09218A	Electrolytic Capacitor 47μ 16V (LN)	R107,108	OB01879A	Carbon Resistor 33K ERD-25V J			
R126,134	OB01833A	Carbon Resistor 10K ERD-25V J	C146,246	OB09219A	Electrolytic Capacitor 6.8μ 16V (LN)	207,208					
226,234			C333	OB01400A	Electrolytic Capacitor 100μ 16V	R109,209	OB09208A	Metal Film Resistor 3.3K SN15K2E F			
R128,132	OB05661A	Carbon Resistor 22K ERD-25V J				R110,210	OB05562A	Carbon Resistor 47K ERD-25V J			
133,228						R111,113	OB05600A	Carbon Resistor 270K ERD-25V J			
232,233						211,213					
R129,229	OB01795A	Carbon Resistor 4.7K ERD-25V J				R112,212	OB05823A	Carbon Resistor 6.2K ERD-25V J			

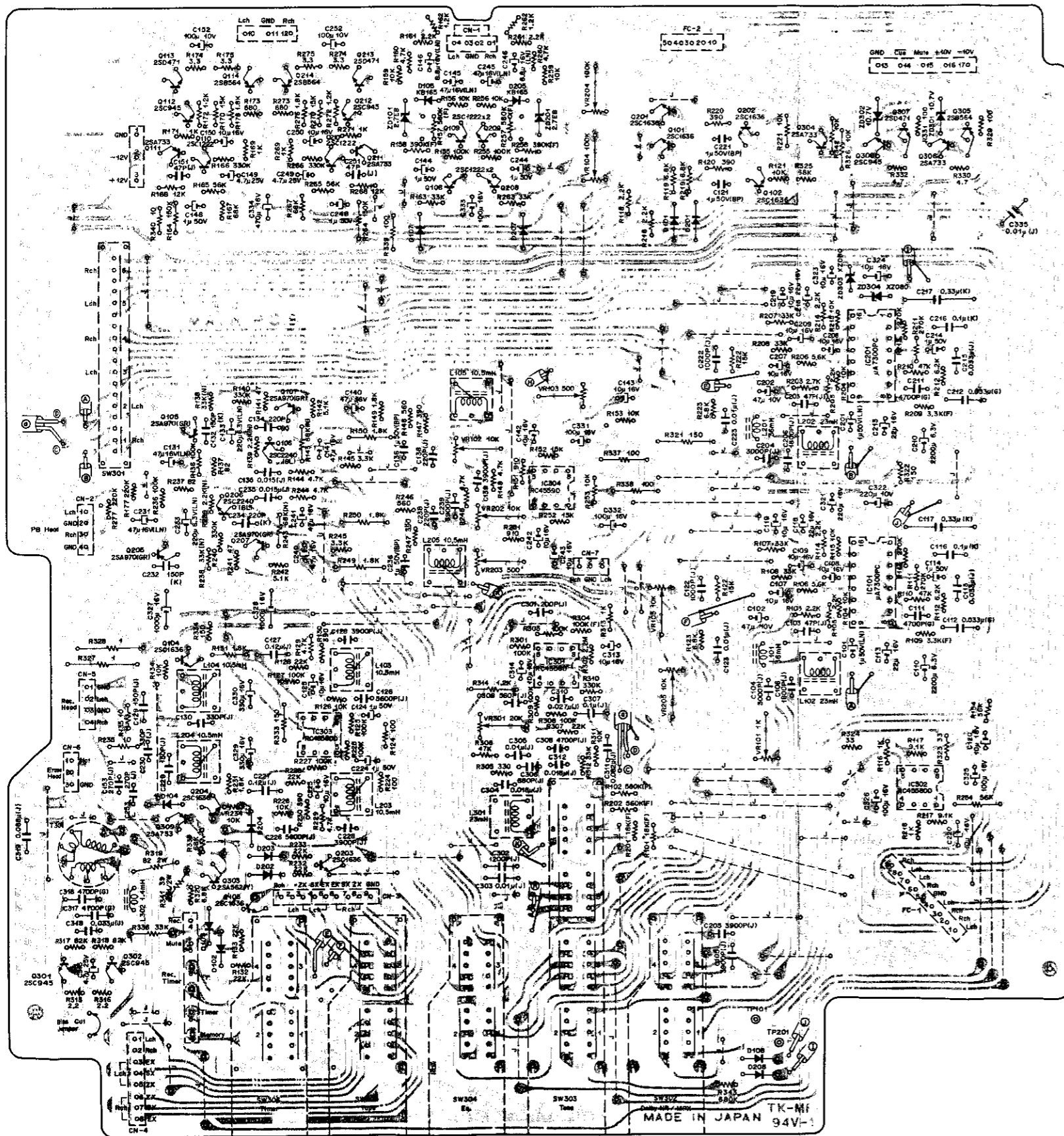

Fig. 7.6.2 Serial Nos.: A30201001 - A30206059

Schematic Ref. No.	Part No.	Description	
	BA04015B	Main P.C.B. Ass'y	
		Serial Nos.: A30201001 - A30206059	
		- PB Eq. Amp. -	
Q105,107 205,207	OB06180A	Transistor	2SA970 (GR)
Q106,206	OB06142A	Transistor	2SC2240 (BL)
L105,205	OB00068A	Trap Coil	10.5mH
VR102,202	OB07236A	Semi-fixed Volume	10K
R136,236	OB01920A	Carbon Resistor	100K ERD-25V J
R137,237	OB05503A	Carbon Resistor	82 ERD-25V J
R138,238	OB09239A	Carbon Resistor	33K ERD-25VS J (Noiseless)
R139,239	OB09244A	Carbon Resistor	2.2K ERD-25VS J (Noiseless)
R140,240	OB01921A	Carbon Resistor	330K ERD-25V J
R141,241	OB05569A	Carbon Resistor	47 ERD-25V J
R142,242	OB09186A	Carbon Resistor	5.1K ERD-25V J
R143,243	OB09268A	Carbon Resistor	68K ERD-25VS J (Noiseless)
R144,244 148,248	OB01795A	Carbon Resistor	4.7K ERD-25V J
R145,245	OB01793A	Carbon Resistor	3.3K ERD-25V J
R146,246	OB05678A	Carbon Resistor	560 ERD-25V J
R147,247	OB05688A	Carbon Resistor	390 ERD-25V J
R149	OB01830A	Carbon Resistor	1.8K ERD-25V J
R150,249 250	OB05614A	Carbon Resistor	1.8K ERD-25T J
R177,277	OB05596A	Carbon Resistor	220K ERD-25V J
C131,231	OB09218A	Electrolytic Capacitor	47μ 16V (LN)
C132,232	OB09281A	Ceramic Capacitor	150P 50V K
C133,233	OB09151A	Electrolytic Capacitor	220μ 6.3V (LN)
C134,234	OB09283A	Ceramic Capacitor	220P 50V K
C135,235	OB05557A	Mylar Capacitor	0.015μ 50V J
C136,236	OB09187A	Electrolytic Capacitor	1μ 50V (BP)
C138,238	OB09247A	Mica Capacitor	220P 50V J
C139,239	OB01804A	Mylar Capacitor	3900P 50V J
C140,141 240,241	OB01403A	Electrolytic Capacitor	47μ 16V
		- Line Amp. -	
IC302	OB06146A	IC	RC4558DD
Q101,102 201,202	OB06070A	Transistor	2SC1636
Q304,306	OB06013A	Transistor	2SA733
Q305	OB06069A	Transistor	2SB564
Q307	OB06066A	Transistor	2SD471
Q308	OB01872A	Transistor	2SC945
D101,201	OB06181A	Silicon Diode	1SS53
ZD301,302	OB06199A	Zener Diode	10.7V
R116,216	OB01781A	Carbon Resistor	1K ERD-25V J
R117,217	OB09184A	Carbon Resistor	9.1K ERD-25V J
R118,218	OB05566A	Carbon Resistor	2.2K ERD-25V J
R119,219	OB01877A	Carbon Resistor	6.8K ERD-25V J
R120,220	OB05688A	Carbon Resistor	390 ERD-25V J
R121,221	OB01833A	Carbon Resistor	10K ERD-25V J
R323,324	OB09210A	Fail Safe Type Resistor	33 RDF25S J
R325	OB01902A	Carbon Resistor	68K ERD-25V J
R326,342	OB05600A	Carbon Resistor	270K ERD-25V J
R327,328	OB09214A	Fail Safe Type Resistor	1 RDF25S J

Schematic Ref. No.	Part No.	Description	Schematic Ref. No.	Part No.	Description	Schematic Ref. No.	Part No.	Description	Schematic Ref. No.	Part No.	Description
R329,331	OB09215A	Fail Safe Type Resistor 100 RDF25S J	R130,230	OB05688A	Carbon Resistor 390 ERD-25V J			— Headphone Amp. —	R203	OB01782A	Carbon Resistor 2.7K ERD-25V J
R330,332	OB09243A	Fail Safe Type Resistor 4.7 RDF50S J	R131,231	OB01830A	Carbon Resistor 1.8K ERD-25V J	Q110,210	OB06062A	Transistor 2SC1222	R321,322	OB09213A	Fail Safe Type Resistor 150 RDF25S J
C120,220	OB01412A	Electrolytic Capacitor 10μ 16V	R135,235	OB05663A	Carbon Resistor 10 ERD-25V J	Q111,211	OB06013A	Transistor 2SA733	R343	OB05597A	Carbon Resistor 680K ERD-25V J
C121,221	OB09187A	Electrolytic Capacitor 1μ 50V (BP)	R333,334	OB09213A	Fail Safe Type Resistor 150 RDF25S J	Q112,212	OB01872A	Transistor 2SA945	C101,201	OB09223A	Electrolytic Capacitor 1μ 50V (LN)
C325,326	OB01400A	Electrolytic Capacitor 100μ 16V	R335	OB01902A	Carbon Resistor 68K ERD-25V J	Q113,213	OB06066A	Transistor 2SD471	C102,202	OB01836A	Electrolytic Capacitor 47μ 10V
C327,328	OB01397A	Electrolytic Capacitor 1000μ 16V	R336	OB01879A	Carbon Resistor 33K ERD-25V J	Q114,214	OB06069A	Transistor 2SB564	C103,203	OB09242A	Mica Capacitor 47P 50V J
C335	OB05681A	Mylar Capacitor 0.01μ 50V J	C122,222	OB05550A	Mylar Capacitor 1000P 50V J	R164,264	OB05593A	Carbon Resistor 150K ERD-25V J	C104,204	OB09262A	PP Capacitor 3000P 50V J
	— Tone Osc. —		C123,223	OB05681A	Mylar Capacitor 0.01μ 50V J	R165,265	OB0563A	Carbon Resistor 56K ERD-25V J	C105,205	OB01804A	Mylar Capacitor 3900P 50V J
IC301	OB06124B	IC RC4558D	C124,224	OB01405A	Electrolytic Capacitor 1μ 50V	R166,266	OB01921A	Carbon Resistor 330K ERD-25V J	C106,206	OB01913A	Mylar Capacitor 1800P 50V J
L301	OB03563A	19K Coil 23mH	C125,225	OB01412A	Electrolytic Capacitor 10μ 16V	R167,267	OB01902A	Carbon Resistor 68K ERD-25V J	C107,108	OB01412A	Electrolytic Capacitor 10μ 16V
VR301	OB09093A	Semi-fixed Volume 20K	C126,226	OB05659A	Mylar Capacitor 5600P 50V J	R168,268	OB05650A	Carbon Resistor 12K ERD-25V J	109,119		
R101,201	OB09205A	Metal Film Resistor 18K SN15K2E F	C127,227	OB05909A	Mylar Capacitor 0.12μ 50V J	R169,171	OB01781A	Carbon Resistor 1K ERD-25V J	207,208		
R102,202	OB09206A	Metal Film Resistor 560K SN15K2E F	C128,228	OB01804A	Mylar Capacitor 3900P 50V J	269,271			209,219		
R301,303	OB01920A	Carbon Resistor 100K ERD-25V J	C129,229	OB09246A	Mica Capacitor 150P 50V J	R170,270	OB05591A	Carbon Resistor 15K ERD-25V J	323,324		
308,309			C130,230	OB09322A	PP Capacitor 330P 100V J	R172,272	OB05655A	Carbon Resistor 1.2K ERD-25V J	C110,210	OB09257A	Electrolytic Capacitor 2200μ 6.3V
R302	OB05672A	Carbon Resistor 2.2M ERD-25V J	C329,330	OB01502A	Electrolytic Capacitor 330μ 16V	R173,273	OB05559A	Carbon Resistor 680 ERD-25V J	C111,211	OB09191A	PP Capacitor 4700P 100V G
R304	OB09269A	Metal Film Resistor 100K ERD-25V K F		— Bias Osc. —		R174,175	OB05779A	Carbon Resistor 3.3 ERD-25V J	C112,212	OB09240A	PP Capacitor 0.033μ 100V G
R305	OB01789A	Carbon Resistor 330 ERD-25V J	Q301,302	OB01872A	Transistor 2SC945	R176,276	OB01830A	Carbon Resistor 1.8K ERD-25V J	C113,118	OB01862A	Electrolytic Capacitor 22μ 16V
R306	OB05662A	Carbon Resistor 47K ERD-25V J	Q303	OB06202A	Transistor 2SA562(Y)	R340	OB09216A	Fail Safe Type Resistor 10 RDF25S J	213,218		
R307	OB05661A	Carbon Resistor 22K ERD-25V J	T301	OB06613A	Osc. Coil	C148,248	OB01405A	Electrolytic Capacitor 1μ 50V	C114,214	OB01405A	Electrolytic Capacitor 1μ 50V
R310	OB01921A	Carbon Resistor 330K ERD-25V J	L302	OB03861A	Inductor 1.4mH	C149,249	OB01402A	Electrolytic Capacitor 4.7μ 25V	C115,215	OB05683A	Mylar Capacitor 0.033μ 50V J
R311	OB01833A	Carbon Resistor 10K ERD-25V J	R315,316	OB09212A	Fail Safe Type Resistor 2.2RDF25S J	C150,250	OB01412A	Electrolytic Capacitor 10μ 16V	C116,216	OB01603A	Mylar Capacitor 0.1μ 50V K
R312	OB01879A	Carbon Resistor 33K ERD-25V J	R317,318	OB01564A	Carbon Resistor 82K ERD-25V J	C151,251	OB09280A	Ceramic Capacitor 47P 50V J	C117,217	OB01602A	Mylar Capacitor 0.33μ 50V K
R313	OB01857A	Carbon Resistor 1K ERD-25T J	R319	OB09294A	Fail Safe Type Resistor 82 RSF-2B J	C152,252	OB05885A	Electrolytic Capacitor 100μ 10V	C321,322	OB01398A	Electrolytic Capacitor 220μ 16V
R314	OB05623A	Carbon Resistor 1.2K ERD-25T J	R320	OB01877A	Carbon Resistor 6.8K ERD-25V J	C334	OB01392A	Electrolytic Capacitor 470μ 16V			
C301	OB09275A	Mica Capacitor 200P 50V J	R341	OB09296A	Fail Safe Type Resistor 39 RSF-1/2B J		— Monitor Amp. —		SW301	OB07814B	Main P.C.B. A302
C302	OB05687A	Mylar Capacitor 1200P 50V J	R153,253	OB09284A	Ceramic Capacitor 270P 50V J	IC304	OB06127A	IC RC4559D	SW302,305	OB07267A	Record Switch A302
C303,305	OB05681A	Mylar Capacitor 0.01μ 50V J	C315	OB01402A	Electrolytic Capacitor 4.7μ 25V	VR103,203	OB07159A	Semi-fixed Volume 500	SW303	OB07264A	Rotary Slide Switch C
C304,312	OB05832A	Mylar Capacitor 0.018μ 50V J		— Meter Amp. —		VR105,205	OB07236A	Semi-fixed Volume 10K	SW304	OB07266A	Rotary Slide Switch E
C306	OB09235A	PP Capacitor 680P 100V J	C316,317	OB09191A	PP Capacitor 4700P 100V G	R151,251	OB09272A	Carbon Resistor 910 ERD-25V J	SW306	OB07262A	Rotary Slide Switch A
C307	OB01780A	Mylar Capacitor 0.1μ 50V J	C318	OB05583A	Mylar Capacitor 0.033μ 50V J	R152,252	OB05591A	Carbon Resistor 15K ERD-25V J	TP101,201	OB07263A	Rotary Slide Switch B
C308	OB05652A	Mylar Capacitor 4700P 50V J	C319	OB09254A	PP Capacitor 0.068μ 100V J	R153,253	OB01833A	Carbon Resistor 10K ERD-25V J	OB03924A	OB03924A	Gate Pin
C309	OB09323A	PP Capacitor 560P 100V J				R337,338	OB09215A	Fail Safe Type Resistor 100 RDF25S J	OC08569C	OC08569C	Record Wire Holder (1 pce.)
C310	OB09045A	Mylar Capacitor 0.027μ 50V J				C142,143	OB01412A	Electrolytic Capacitor 10μ 16V	OB08375A	OB08375A	4P-S Post (1 pce.)
C311	OB05685A	Mylar Capacitor 0.082μ 50V J				242,243			OB08185A	OB08185A	3P-T Post (2 pcs.)
C313,314	OB01412A	Electrolytic Capacitor 10μ 16V	Q108,109	OB06062A	Transistor 2SC1222	C331,332	OB01400A	Electrolytic Capacitor 100μ 16V	OB08236A	OB08236A	4P-T Post (2 pcs.)
	— Rec. Amp. —		208,209						OB08334A	OB08334A	8P-T Post (1 pce.)
IC303	OB06146A	IC RC4558DD	D105,205	OB06007A	Silicon Varistor KB-165				OB08614A	OB08614A	9P-T Post (1 pce.)
Q103,104	OB06070A	Transistor 2SC1636	D107,207	OB06181A	Silicon Diode 1SS53				OB08542A	OB08542A	Wrapping Pin 1P (1 pce.)
Q309	OB06013A	Transistor 2SA733	ZD101,201	OB06191A	Zener Diode 2.7EB 2.7V	IC101,201	OB06175A	IC μA7300PC	OB08544A	OB08544A	Wrapping Pin 3P (2 pcs.)
D102,103	OB06181A	Silicon Diode 1SS53	VR104,204	OB03832A	Semi-fixed Volume 100K	D108,208	OB06181A	Silicon Diode 1SS53	OB08545A	OB08545A	Wrapping Pin 4P (1 pce.)
104,202			R154,254	OB05563A	Carbon Resistor 56K ERD-25V J	ZD303,304	OB06090A	Zener Diode ZX080	OB08547A	OB08547A	Wrapping Pin 6P (1 pce.)
203,204			R155,255	OB01920A	Carbon Resistor 100K ERD-25V J	L101,201	OB03919A	Inductor 36mH	OC08570A	OC08570A	Record Spring Holder (1 pce.)
L103,104	OB00068A	Trap Coil 10.5mH	R156,159	OB01833A	Carbon Resistor 10K ERD-25V J	L102,202	OB03563A	19K Coil 23mH	OC08144C	OC08144C	Record Spring (1 pce.)
203,204			R157,257	OB09206A	Metal Film Resistor 560K SN15K2E F	VR101	OB07178A	Semi-fixed Volume 1K	OE00037A	OE00037A	Earth Lug B-5 (1 pce.)
R122,222	OB05591A	Carbon Resistor 15K ERD-25V J	R158,258	OB09207A	Metal Film Resistor 390K SN15K2E F	R103,105	OB05566A	Carbon Resistor 2.2K ERD-25V J	OE00172A	OE00172A	Washer Toothed Lock 3mm (1 pce.)
R123,223	OB01877A	Carbon Resistor 6.8K ERD-25V J	R160,260	OB01795A	Carbon Resistor 4.7K ERD-25V J	114,205			OE00788A	OE00788A	BT Screw M2x8 Phillips Pan Head (1 pce.)
R124,224	OB05558A	Carbon Resistor 100 ERD-25V J	R161,261	OB05566A	Carbon Resistor 2.2K ERD-25V J	214			OE00831A	OE00831A	BT Screw M3x10 Phillips Pan Head (1 pce.)
R125,127	OB01920A	Carbon Resistor 100K ERD-25V J	R162,262	OB05565A	Carbon Resistor 1.2K ERD-25V J	R104,115	OB01833A	Carbon Resistor 10K ERD-25V J			
225,227			R163,263	OB01879A	Carbon Resistor 33K ERD-25V J	204,215					
R126,134	OB01833A	Carbon Resistor 10K ERD-25V J	R339	OB09215A	Fail Safe Type Resistor 100 RDF25S J	R106,206	OB05673A	Carbon Resistor 5.6K ERD-25V J			
226,234			C144,244	OB01405A	Electrolytic Capacitor 1μ 50V	R107,108	OB01879A	Carbon Resistor 33K ERD-25V J			
R128,132	OB05661A	Carbon Resistor 22K ERD-25V J	C145,245	OB09218A	Electrolytic Capacitor 47μ 16V (LN)	207,208					
133,228			C146,246	OB09219A	Electrolytic Capacitor 6.8μ 16V (LN)	R109,209	OB09208A	Metal Film Resistor 3.3K SN15K2E F			
232,233			C333	OB01400A	Electrolytic Capacitor 100μ 16V	R110,210	OB05662A	Carbon Resistor 47K ERD-25V J			
R129,229	OB01795A	Carbon Resistor 4.7K ERD-25V J				R111,113	OB05600A	Carbon Resistor 270K ERD-25V J			

7.7. Logic P.C.B. Ass'y

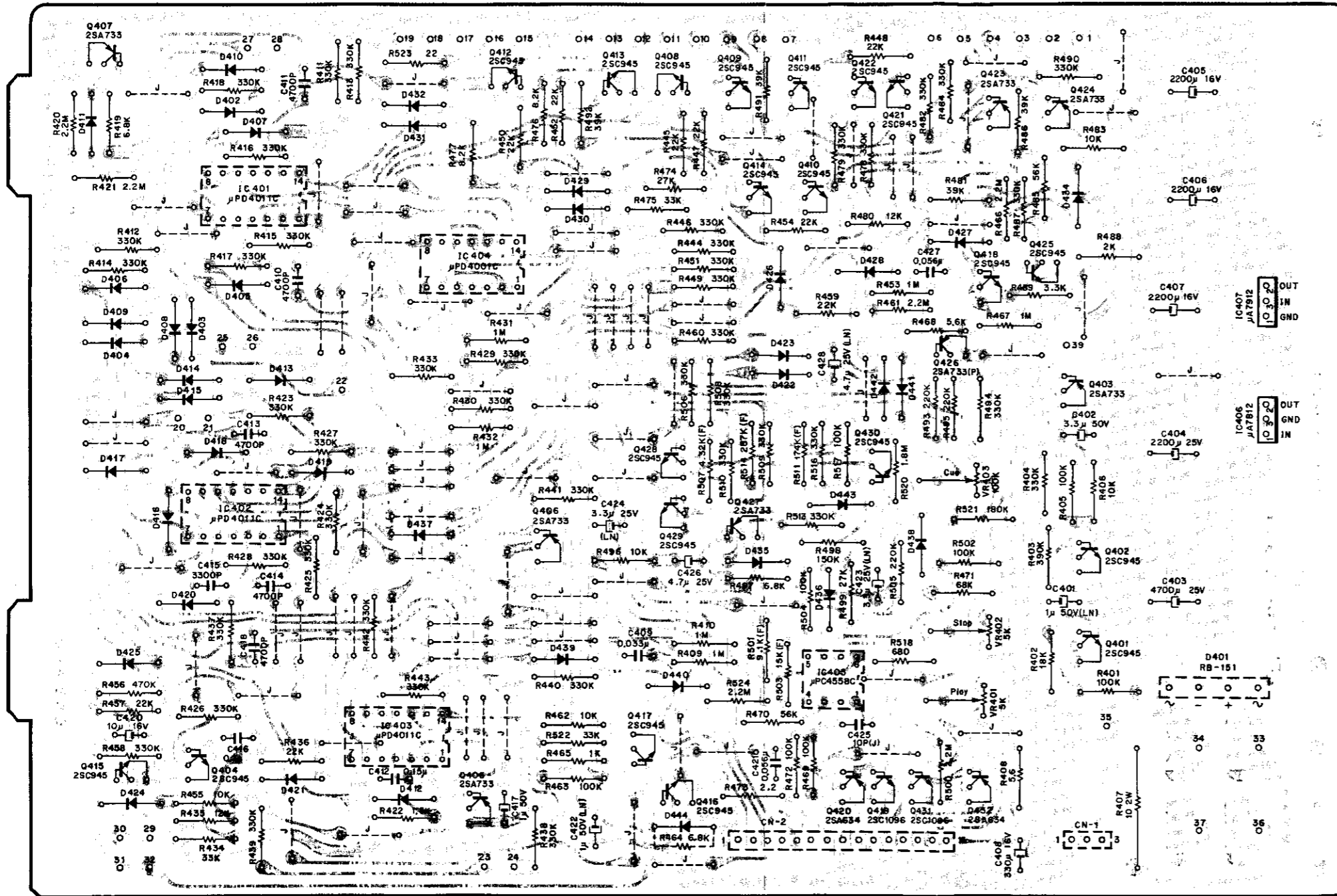

Fig. 7.7.1 Serial No.: A30206070 -

Note: Diode is 1SS53, 1S953, or 1S1555 unless otherwise specified.

Schematic Ref. No.	Part No.	Description	Schematic Ref. No.	Part No.	Description	Schematic Ref. No.	Part No.	Description
	BA04073B	Logic P.C.B. Ass'y (U.S.A., Canada & Japan)	R422	0B05698A	Carbon Resistor 1.5K ERD-25T J		0E00037A	Earth Lug B-5 (1 pce.)
	BA04109B	Logic P.C.B. Ass'y (Sweden, Swiss, UK, Germany & Australia) Serial No.: A30206070 -	R434, 475 522 R435, 480 R436, 445 447, 448 450, 452 454, 457 459	0B05509A 0B09263A 0B05615A	Carbon Resistor 33K ERD-25T J Carbon Resistor 12K ERD-25T J Carbon Resistor 22K ERD-25T J	*	-	Wrapping Pin (33 pcs.)
	0B07841C	Logic P.C.B.				*	0B08349A	Jumper Wire (85 pcs.)
IC401-403	0B06178A	IC μ PD4011C				*	0B08161U	Fuse Clip (4 pcs.)
IC404	0B06143A	IC μ PD4001C				*	0M04062A	Fuse 630mAT 250V (2 pcs.)
IC405	0B06124B	IC μ PC4558C	R456	0B01684A	Carbon Resistor 470K ERD-25T J			Fuse Label 630mAT (1 pce.)
IC406	0B06192A	Regulator μ A7812PC	R465	0B01857A	Carbon Resistor 1K ERD-25T J			
IC407	0B06193A	Regulator μ A7912PC	R468	0B01887A	Carbon Resistor 5.6K ERD-25T J			
Q401, 402 404 408-418 421, 422 425, 428 429, 430	0B01872A	Transistor 2SC945 (20 pcs.)	R470, 485 R471 R473 R474, 499 R476, 477 R481, 486 491, 492	0B05508A 0B05692A 0B09212A 0B05743A 0B01856A 0B01854A	Carbon Resistor 56K ERD-25T J Carbon Resistor 68K ERD-25T J Fail Safe Type Resistor 2.2 RDF-25S J Carbon Resistor 27K ERD-25T J Carbon Resistor 8.2K ERD-25T J Carbon Resistor 39K ERD-25T J			
Q403, 405 406, 407 423, 424 427	0B06013A	Transistor 2SA733 (Q, P)	R488 R489 R493, 495	0B09301A 0B01681A 0B05625A	Carbon Resistor 2K ERD-25T J Carbon Resistor 3.3K ERD-25T J Carbon Resistor 220K ERD-25T J			
Q419, 431	0B06020A	Transistor 2SC1096	505					
Q420, 432	0B06012A	Transistor 2SA634	R498	0B05626A	Carbon Resistor 150K ERD-25T J			
Q426	0B06155A	Transistor 2SA733 (P)	R501	0B09328A	Metal Film Resistor 9.1K SN15K2E F			
D401	0B06183A	Diode Bridge RB-151	R503	0B09340A	Metal Film Resistor 15K SN15K2E F			
D402-432 434-444	0B06181A	Silicon Diode 1SS53 (42 pcs.)	R507 R511 R514 R518 R520 R521 R523	0B09365A 0B09367A 0B09366A 0B05794A 0B05680A 0B05640A 0B09049A	Metal Film Resistor 4.32K SN15K2E F Metal Film Resistor 174K SN15K2E F Metal Film Resistor 287K SN15K2E F Carbon Resistor 680 ERD-25T J Carbon Resistor 1.8M ERD-25T J Carbon Resistor 180K ERD-25T J Fail Safe Type Resistor 22 RDF-25S J			
VR401, 402	0B03831A	Semi-fixed Volume 5K	C401, 422	0B09223A	Electrolytic Capacitor 1 μ 50V (LN)			
VR403	0B03832A	Semi-fixed Volume 100K	C402	0B01863A	Electrolytic Capacitor 3.3 μ 50V			
R401, 405 463, 469 472, 502 504, 517	0B01889A	Carbon Resistor 100K ERD-25T J	C403 C404 C405, 406 407 C408 C409 C410, 411 413, 414 418	0B09250A 0B05654A 0B01406A	Electrolytic Capacitor 4700 μ 25V Electrolytic Capacitor 2200 μ 25V Electrolytic Capacitor 2200 μ 16V			
R402	0B05560A	Carbon Resistor 18K ERD-25T J	C412	0B01502A	Electrolytic Capacitor 330 μ 16V			
R403	0B05676A	Carbon Resistor 390K ERD-25T J	C415	0B05513A	Mylar Capacitor 0.033 μ 50V			
R404	0B05627A	Carbon Resistor 330K ERD-25T J	C416	0B05556A	Mylar Capacitor 4700P 50V			
411-418 423-430 433 437-444 446, 449 451, 458 460, 478 479, 482 484, 487 490, 494 506, 508 509, 510 513, 516			C417 C420 C421, 427 C423, 424 C425 C426 C428	0B09171A 0B09166A 0B00093A 0B01405A 0B01412A 0B01676A 0B09147A 0B09277A 0B01402A 0B09333A	Mylar Capacitor 0.15 μ 50V Mylar Capacitor 3300P 50V Mylar Capacitor 0.1 μ 50V Electrolytic Capacitor 1 μ 50V Electrolytic Capacitor 10 μ 16V Mylar Capacitor 0.056 μ 50V Electrolytic Capacitor 3.3 μ 25V (LN) Ceramic Capacitor 10P 50V J Electrolytic Capacitor 4.7 μ 25V Electrolytic Capacitor 4.7 μ 25V (LN)			
R406, 455 462, 483 496	0B01888A	Carbon Resistor 10K ERD-25T J						
R407	0B09179A	Fail Safe Type Resistor 10 SF2B J						
R408	0B05940A	Fail Safe Type Resistor 5.6 ERD-14F J						
R409, 410 431, 432 453, 467	0B05776A	Carbon Resistor 1M ERD-25T J						
R419, 484 497	0B01682A	Carbon Resistor 6.8K ERD-25T J						
R420, 421 461, 466 500, 524	0B05671A	Carbon Resistor 2.2M ERD-25T J						
								* included only in Logic P.C.B. Ass'y (BA04109B)

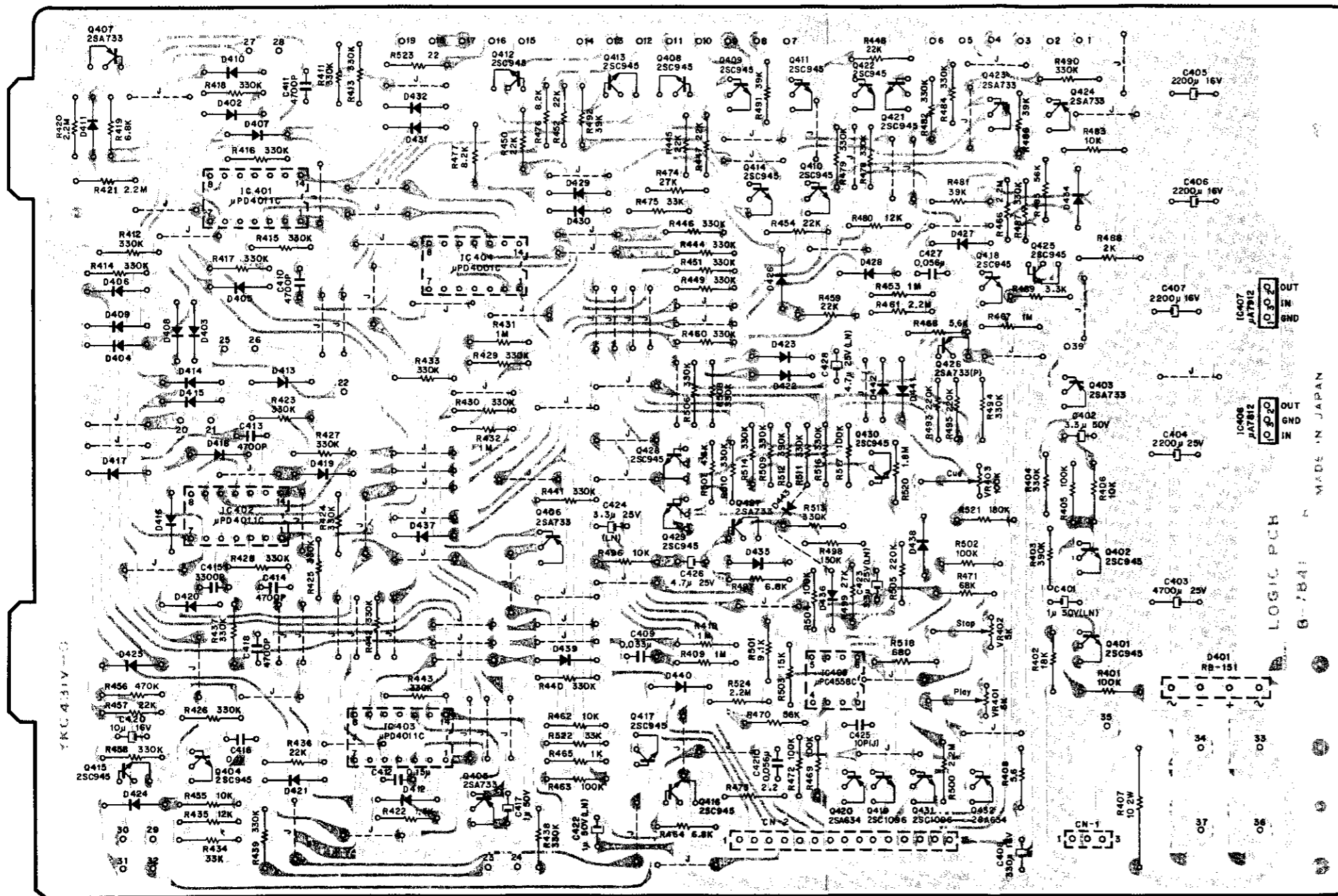

Fig. 7.7.2 Serial Nos.: A30205002 - A30206069

Note: Diode is 1SS53, 1S953, or 1S1555 unless otherwise specified.

Schematic Ref. No.	Part No.	Description	Schematic Ref. No.	Part No.	Description	Schematic Ref. No.	Part No.	Description
	BA04073A	Logic P.C.B. Ass'y (U.S.A., Canada & Japan)	R420, 421	0B05671A	Carbon Resistor 2.2M ERD-25T J		0E00037A	Earth Lug B-5 (1 pce.)
	BA04109A	Logic P.C.B. Ass'y (Sweden, Swiss, UK, Germany & Australia) Serial Nos.: A30205002 - A30206069	461, 466 500, 524				-	Wrapping Pin (33 pcs.)
			R422	0B05698A	Carbon Resistor 1.5K ERD-25T J	*	0B08349A	Fuse Clip (4 pcs.)
			R434, 475	0B05509A	Carbon Resistor 33K ERD-25T J	*	0B08161U	Fuse 630mAT 250V (2 pcs.)
			522			*	0M04062A	Fuse Label 630mAT (1 pce.)
	0B07841B	Logic P.C.B.	R435, 480	0B09263A	Carbon Resistor 12K ERD-25T J			
IC401-403	0B06178A	IC μ PD4011C	R436, 445	0B05615A	Carbon Resistor 22K ERD-25T J			* included only in Logic P.C.B. Ass'y (BA04109A)
IC404	0B06143A	IC μ PD4001C	447, 448					
IC405	0B06124B	IC μ PC4558C	450, 452					
IC406	0B06192A	Regulator μ A7812PC	454, 457					
IC407	0B06193A	Regulator μ A7912PC	459					
Q401, 402	0B01872A	Transistor 2SC945 (20 pcs.)	R456	0B01684A	Carbon Resistor 470K ERD-25T J			
404			R465	0B01857A	Carbon Resistor 1K ERD-25T J			
408-418			R468	0B01887A	Carbon Resistor 5.6K ERD-25T J			
421, 422			R470, 485	0B05508A	Carbon Resistor 56K ERD-25T J			
425, 428			R471	0B05692A	Carbon Resistor 68K ERD-25T J			
429, 430			R473	0B09212A	Fail Safe Type Resistor 2.2 RDF-25S J			
Q403, 405	0B06013A	Transistor 2SA733 (Q, P)	R474, 499	0B05743A	Carbon Resistor 27K ERD-25T J			
406, 407			R476, 477	0B01856A	Carbon Resistor 8.2K ERD-25T J			
423, 424			R481, 486	0B01854A	Carbon Resistor 39K ERD-25T J			
427			491, 492					
Q419, 431	0B06020A	Transistor 2SC1096	R488	0B09301A	Carbon Resistor 2K ERD-25T J			
Q420, 432	0B06012A	Transistor 2SA634	R489	0B01681A	Carbon Resistor 3.3K ERD-25T J			
Q426	0B06155A	Transistor 2SA733 (P)	R493, 495	0B05625A	Carbon Resistor 220K ERD-25T J			
D401	0B06183A	Diode Bridge RB-151	505					
D402-432	0B06181A	Silicon Diode 1SS53 (41 pcs.)	R498	0B05626A	Carbon Resistor 150K ERD-25T J			
434-443			R501	0B09226A	Carbon Resistor 9.1K ERD-25T J			
VR401, 402	0B03831A	Semi-fixed Volume 5K	R503	0B01683A	Carbon Resistor 15K ERD-25T J			
VR403	0B03832A	Semi-fixed Volume 100K	R507	0B09307A	Carbon Resistor 4.3K ERD-25T J			
R401, 405	0B01889A	Carbon Resistor 100K ERD-25T J	R518	0B05794A	Carbon Resistor 680 ERD-25T J			
463, 469			R520	0B05680A	Carbon Resistor 1.8M ERD-25T J			
472, 502			R521	0B05640A	Carbon Resistor 180K ERD-25T J			
504, 517			R523	0B09049A	Fail Safe Type Resistor 22 RDF-25S J			
R402	0B05560A	Carbon Resistor 18K ERD-25T J	C401, 422	0B09223A	Electrolytic Capacitor 1 μ 50V (LN)			
R403, 512	0B05676A	Carbon Resistor 390K ERD-25T J	C402	0B01863A	Electrolytic Capacitor 3.3 μ 50V			
R404	0B05627A	Carbon Resistor 330K ERD-25T J	C403	0B09250A	Electrolytic Capacitor 4700 μ 25V			
411-418			C404	0B05654A	Electrolytic Capacitor 2200 μ 25V			
423-430			C405, 406	0B01406A	Electrolytic Capacitor 2200 μ 16V			
433			407					
437-444			C408	0B01502A	Electrolytic Capacitor 330 μ 16V			
446, 449			C409	0B05513A	Mylar Capacitor 0.033 μ 50V			
451, 458			C410, 411	0B05556A	Mylar Capacitor 4700P 50V			
460, 478			413, 414					
479, 482			418					
484, 487			C412	0B09171A	Mylar Capacitor 0.15 μ 50V			
490, 494			C415	0B09166A	Mylar Capacitor 3300P 50V			
506, 508			C416	0B00093A	Mylar Capacitor 0.1 μ 50V			
509, 510			C417	0B01405A	Electrolytic Capacitor 1 μ 50V			
511, 513			C420	0B01412A	Electrolytic Capacitor 10 μ 16V			
514, 516			C421, 427	0B01676A	Mylar Capacitor 0.056 μ 50V			
R406, 455	0B01888A	Carbon Resistor 10K ERD-25T J	C423, 424	0B09147A	Electrolytic Capacitor 3.3 μ 25V (LN)			
462, 483			C425	0B09277A	Ceramic Capacitor 10P 50V J			
496			C426	0B01402A	Electrolytic Capacitor 4.7 μ 25V			
R407	0B09179A	Fail Safe Type Resistor 10 SF2B J	C428	0B09333A	Electrolytic Capacitor 4.7 μ 25V (LN)			
R408	0B05940A	Fail Safe Type Resistor 5.6 ERD-14F J	0B08579A	15P-S Post (1 pce.)				
R409, 410	0B05776A	Carbon Resistor 1M ERD-25T J	0B08184A	3P-S Post (1 pce.)				
431, 432			0B08568B	Heat Sink A301 (1 pce.)				
453, 467			0B08603A	Mica for Transistor (2 pcs.)				
R419, 464	0B01682A	Carbon Resistor 6.8K ERD-25T J	0B08604A	Bushing for Transistor (2 pcs.)				
497			0E00607A	Screw M3x8 Philips Pan Head (2 pcs.)				
			0E00507A	Nut Hex. M3 (2 pcs.)				
			0E00857A	BT Screw M3x6 Philips Binding Head (2 pcs.)				

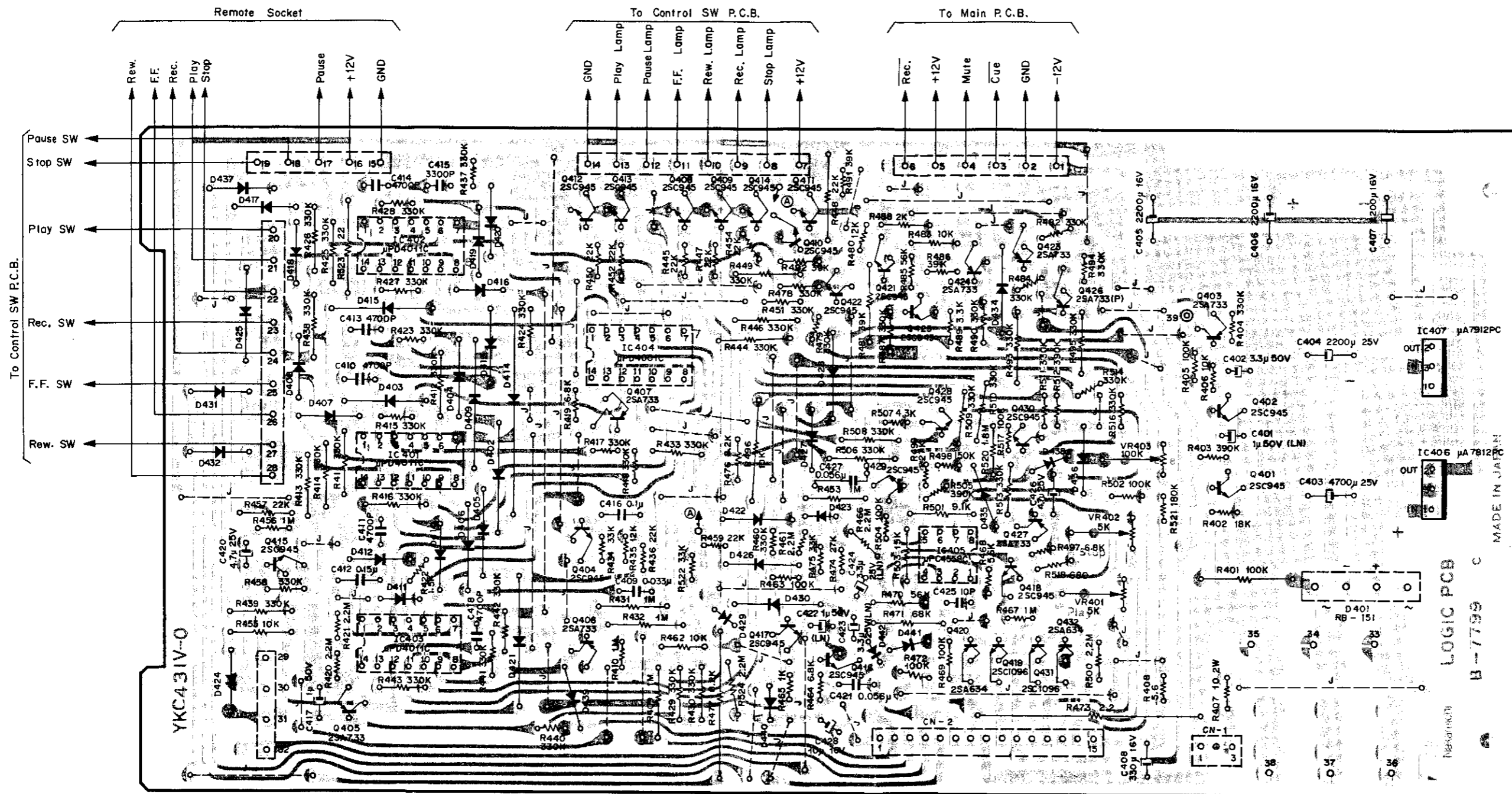

Fig. 7.7.3 Serial Nos.: A30201001 - A30205001

7.8. Lamp P.C.B. Ass'y

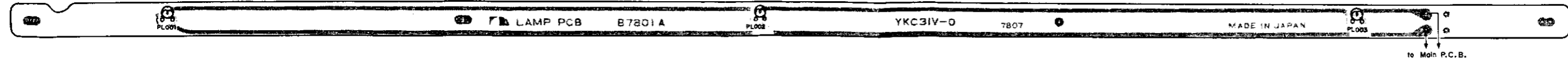

Fig. 7.8

Schematic Ref. No.	Part No.	Description	Schematic Ref. No.	Part No.	Description	Schematic Ref. No.	Part No.	Description
	BA04036B	Logic P.C.B. Ass'y (U.S.A., Canada & Japan)	R411, 412	0B05627A	Carbon Resistor 330K ERD-25T J	C423, 424	0B09147A	Electrolytic Capacitor 3.3μ 25V (LN)
	BA04040A	Logic P.C.B. Ass'y (Sweden, Swiss, UK, Germany & Australia) Serial Nos.: A30201001 - A30205001	413, 414			C425	0B09277A	Ceramic Capacitor 10P 50V J
			416, 425			C428	0B01412A	Electrolytic Capacitor 10μ 16V
	OB07799C	Logic P.C.B.	426, 438				0B08542A	Wrapping Pin 1P (1 pce.)
IC401-403	OB06178A	IC μPD4011C (3 pcs.)	439, 444				0B08545A	Wrapping Pin 4P (1 pce.)
IC404	OB06143A	IC μPC4001C	446, 449				0B08546A	Wrapping Pin 5P (1 pce.)
IC405	OB06124B	IC μPC4558C	493, 495				0B08547A	Wrapping Pin 6P (1 pce.)
IC406	OB06192A	Regulator μA7812PC	506, 508				0B08549A	Wrapping Pin 8P (1 pce.)
IC407	OB06193A	Regulator μA7912PC	509, 510	R419, 464	0B01877A	Carbon Resistor 6.8K ERD-25V J	0B08550A	Wrapping Pin 9P (1 pce.)
Q401, 402	OB01872A	Transistor 2SC945 (20 pcs.)	497	R420, 421	0B05672A	Carbon Resistor 2.2M ERD-25V J	0B08184A	3P-S Post (1 pce.)
404			461, 466				0B08579A	15P-S Post (1 pce.)
408-418			500, 524				0B08568B	Heat Sink A301 (1 pce.)
421, 422			R422	0B05505A	Carbon Resistor 1.5K ERD-25V J		0E00607A	Screw M3x8 Philips Pan Head (3A) (2 pcs.)
425, 428			R434, 475	0B01879A	Carbon Resistor 33K ERD-25V J		0E00507A	Nut Hex. M3 (2 pcs.)
429, 430			522				0E00857A	BT Screw M3x6 Philips Binding Head (2 pcs.)
Q403, 405	OB06013A	Transistor 2SA733 (Q, P)	R435, 480	0B05650A	Carbon Resistor 12K ERD-25V J		0E00037A	Earth Lug B-5 (1 pce.)
406, 407			R436, 445	0B05661A	Carbon Resistor 22K ERD-25V J		0B08603A	Mica for Transistor (2 pcs.)
423, 424			447, 450				0B08604A	Bushing for Transistor (2 pcs.)
427			452, 454				0B08349A	Fuse Clip (4 pcs.)
Q419, 431	OB06020A	Transistor 2SC1096	457, 459				0B08161U	Fuse 630mAT 250V (2 pcs.)
Q420, 432	OB06012A	Transistor 2SA634	R448	0B05615A	Carbon Resistor 22K ERD-25T J		0M04062A	Fuse Label 630mAT (1 pce.)
Q426	OB06155A	Transistor 2SA733 (P)	R455, 496	0B01888A	Carbon Resistor 10K ERD-25T J			* included only in Logic P.C.B. Ass'y (BA04040A)
D401	OB06183A	Diode Bridge RB-151	R465	0B01781A	Carbon Resistor 1K ERD-25V J			
D402-432	OB06181A	Silicon Diode 1SS53 (40 pcs.)	R468	0B05673A	Carbon Resistor 5.6K ERD-25V J			
434-442			R470, 485	0B05563A	Carbon Resistor 56K ERD-25V J			
VR401, 402	OB03831A	Semi-fixed Volume 5K	R471	0B05692A	Carbon Resistor 68K ERD-25T J			
VR403	OB03832A	Semi-fixed Volume 100K	R473	0B09212A	Fail Safe Type Resistor 2.2 RDF25S J			
R401	OB01889A	Carbon Resistor 100K ERD-25T J	R474, 499	0B05538A	Carbon Resistor 27K ERD-25V J	PL001,002	0B07801A	Lamp P.C.B.
R402	OB05561A	Carbon Resistor 18K ERD-25V J	R476	0B01878A	Carbon Resistor 8.2K ERD-25V J	003	0B08553A	Lamp 14V 80mA
R403, 505	OB05595A	Carbon Resistor 390K ERD-25V J	R477	0B01856A	Carbon Resistor 8.2K ERD-25T J	CN1	0B08575A	3P-H Connector A301
R404, 415	OB01921A	Carbon Resistor 330K ERD-25V J	R481	0B01854A	Carbon Resistor 39K ERD-25T J			
417, 418			R486, 491	0B01885A	Carbon Resistor 39K ERD-25V J			
423, 424			492					
427, 428			R488	0B09168A	Carbon Resistor 2K ERD-25V J			
429, 430			R489	0B01793A	Carbon Resistor 3.3K ERD-25V J			
433, 437			R498	0B05593A	Carbon Resistor 150K ERD-25V J			
440, 441			R501	0B09226A	Carbon Resistor 9.1K ERD-25T J			
442, 443			R503	0B05591A	Carbon Resistor 15K ERD-25V J			
451, 458			R507	0B09225A	Carbon Resistor 4.3K ERD-25V J			
460, 478			R518	0B05559A	Carbon Resistor 680 ERD-25V J			
479, 482			R520	0B05670A	Carbon Resistor 1.8M ERD-25V J			
484, 487			R521	0B05669A	Carbon Resistor 180K ERD-25V J			
490, 494			R523	0B09049A	Fail Safe Type Resistor 22 RDF25S J			
511, 513			C401, 422	0B09223A	Electrolytic Capacitor 1μ 50V (LN)			
514, 516			C402	0B01863A	Electrolytic Capacitor 3.3μ 50V			
R405, 463	OB01920A	Carbon Resistor 100K ERD-25V J	C403	0B09250A	Electrolytic Capacitor 4700μ 25V			
469, 472			C404	0B05654A	Electrolytic Capacitor 2200μ 25V			
502, 504			C405, 406	0B01406A	Electrolytic Capacitor 2200μ 16V			
517			407					
R406, 462	OB01833A	Carbon Resistor 10K ERD-25V J	C408	0B01502A	Electrolytic Capacitor 330μ 16V			
483			C409	0B05513A	Mylar Capacitor 0.033μ 50V			
R407	OB09160A	Fail Safe Type Resistor 10 RSF2B J	C410, 411	0B05556A	Mylar Capacitor 4700P 50V			
R408	OB05940A	Fail Safe Type Resistor 5.6 ERD-14F J	413, 414					
R409, 431	OB05776A	Carbon Resistor 1M ERD-25T J	418					
432, 453			C412	0B09171A	Mylar Capacitor 0.15μ 50V			
R410, 456	OB05564A	Carbon Resistor 1M ERD-25V J	C415	0B09166A	Mylar Capacitor 3300P 50V			
467			C416	0B00093A	Mylar Capacitor 0.1μ 50V			
			C417	0B01405A	Electrolytic Capacitor 1μ 50V			
			C420, 426	0B01402A	Electrolytic Capacitor 4.7μ 25V			
			C421, 427	0B01676A	Mylar Capacitor 0.056μ 50V			

8. MECHANISM ASS'Y AND PARTS LIST

8.1. Synthesis

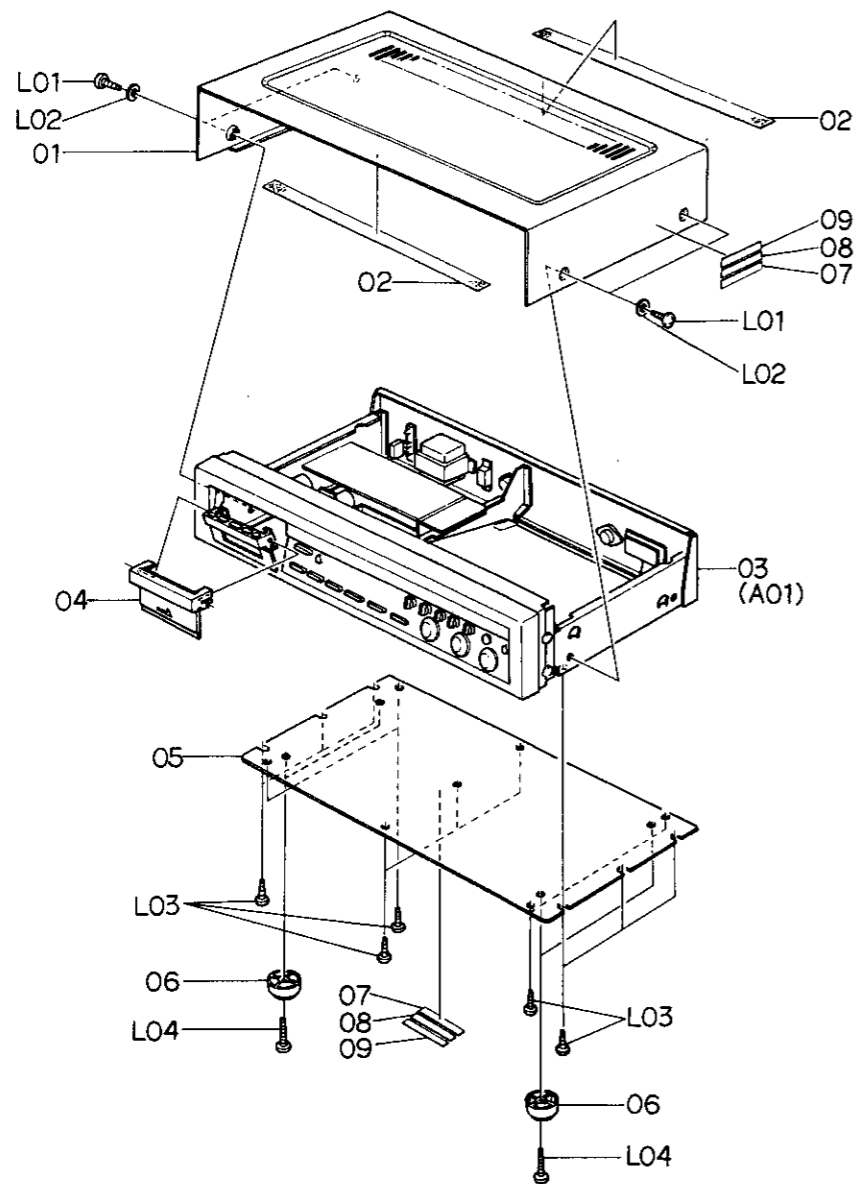

Fig. 8.1

Schematic Ref. No.	Part No.	Description	Q'ty	Schematic Ref. No.	Part No.	Description	Q'ty
	Synthesis			04	0H03689B	Acrylic Cassette Compartment Cover	1
01	0H03681C	Top Coper	1	05	0J03972B	Bottom Cover	1
02	0H03580B	Top Cover Himelon	2	06	0J03825A	Leg S	4
03	JA03450A	Synthesis Mechanism 581 (U.S.A. & Canada)	1	07	0M03799A	Caution Label G	2
	JA03451A	Synthesis Mechanism 581 (Japan)	1	08	0M03800A	Caution Label H	2
	JA03453A	Synthesis Mechanism 581 (Others)	1	09	0M03883A	Lamp Caution Label	2
	JA03455A	Synthesis Mechanism 581 (UK)	1	L01	0E00858A	BT Screw M4x6 Philips Binding Head (Black)	4
	JA03621A	Synthesis Mechanism 581 (Australia)	1	L02	0E00736A	Washer 4mm (Black)	4
	JA03513A	Synthesis Mechanism 581 (220V Class 2)	1	L03	0E00857A	BT Screw M3x6 Philips Binding Head	13
				L04	0E00852A	BT Screw M4x12 Philips Binding Head	4

Schematic Ref. No.	Part No.	Description	Q'ty	Schematic Ref. No.	Part No.	Description	Q'ty
A01	JA03450A	Synthesis Mechanism 581 (U.S.A. & Canada)	1	L02	0E00857A	BT Screw M3x6 Philips Binding Head	1
	JA03451A	Synthesis Mechanism 581 (Japan)	1	L03	0E00867A	BT Screw M4x15 Philips Binding Head	3
	JA03453A	Synthesis Mechanism 581 (Others)	1	L04	0E00878A	BT Screw M4x20 Philips Binding Head	1
	JA03455A	Synthesis Mechanism 581 (UK)	1				
	JA03513A	Synthesis Mechanism 581 (220V Class 2)	1	B01	HA03812A	Front Panel Ass'y 581 Serial No.: A30205253 --	1
	JA03621A	Synthesis Mechanism 581 (Australia) Serial No.: A30205002 --	1	01	HA03776A	Meter Ass'y	1
01	0H03706A	Volume Knob	3	02	HA03777A	Lamp House Cover Ass'y	1
02	0H03712C	Switch Knob	5	03	0H03697A	Aluminum Mirror	1
03	HA03812A	Front Panel Ass'y 581	1	04	0J03979B	Flange Holder	1
04	JA03390A	Headphone Jack Ass'y	1	05	HA03803A	Push Button Ass'y A	1
05	CA08049B	Mechanism Ass'y 581	1	06	HA03805A	Push Button Ass'y C	1
06	JA03468B	Chassis Ass'y 581 (U.S.A. & Canada)	1	07	HA03806A	Counter Reset Button Ass'y	1
	JA03469B	Chassis Ass'y 581 (Japan)	1	08	0J03965C	Control Button Shaft Holder	1
	JA03471B	Chassis Ass'y 581 (Others)	1	09	0J03986B	Control Button Spring	1
	JA03473B	Chassis Ass'y 581 (UK)	1	10	0J03966A	Control Button Shaft	1
	JA03515B	Chassis Ass'y 581 (220V Class 2)	1	11	HA03810A	Control Button A Ass'y	1
	JA03622B	Chassis Ass'y 581 (Australia)	1	12	HA03811A	Control Button B Ass'y	5
L01	0E00877A	ST Screw M3x5 Philips Binding Head	6	13	0H03714B	Hole Plug	1
L02	0E00857A	BT Screw M3x6 Philips Binding Head	1	14	HA03795D	Front Panel Sub Ass'y	1
L03	0E00867A	BT Screw M4x15 Philips Binding Head	3	L01	0E00793A	BT Screw M2x6 Philips Pan Head	5
L04	0E00878A	BT Screw M4x20 Philips Binding Head	1	L02	0E00840A	BT Screw M2x8 Philips Pan Head	1
				L03	0E00100A	Washer 2mm	1
				L04	0E00873A	BT Screw M2.6x5 Philips Binding Head	3
				L05	0E00841A	BT Screw M2x4 Philips Pan Head	4
				L06	0E00794A	BT Screw M2x5 Philips Pan Head	3
A01	JA03450A	Synthesis Mechanism 581 (U.S.A. & Canada)	1	B01	HA03793A	Front Panel Ass'y 581 Serial Nos.: A30201001 -- A30205252	1
	JA03451A	Synthesis Mechanism 581 (Japan)	1	01	HA03776A	Meter Ass'y	1
	JA03453A	Synthesis Mechanism 581 (Others)	1	02	HA03777A	Lamp House Cover Ass'y	1
	JA03455A	Synthesis Mechanism 581 (UK)	1	03	0H03697A	Aluminum Mirror	1
	JA03513A	Synthesis Mechanism 581 (220V Class 2)	1	04	0J03979B	Flange Holder	1
	JA03621A	Synthesis Mechanism 581 (Australia) Serial Nos.: A30201001 -- A30205001	1	05	HA03803A	Push Button Ass'y A	1
01	0H03706A	Volume Knob	3	06	HA03805A	Push Button Ass'y C	1
02	0H03712C	Switch Knob	5	07	HA03806A	Counter Reset Button Ass'y	1
03	HA03812A	Front Panel Ass'y 581	1	08	0J03965C	Control Button Shaft Holder	1
04	JA03390A	Headphone Jack Ass'y	1	09	0J03986B	Control Button Spring	1
05	CA08049B	Mechanism Ass'y 581	1	10	0J03966A	Control Button Shaft	1
06	JA03468A	Chassis Ass'y 581 (U.S.A. & Canada)	1	11	HA03797A	Control Button A Ass'y	1
	JA03469A	Chassis Ass'y 581 (Japan)	1	12	HA03798A	Control Button B Ass'y	5
	JA03471A	Chassis Ass'y 581 (Others)	1	13	0H03714B	Hole Plug	1
	JA03473A	Chassis Ass'y 581 (UK)	1	14	HA03795D	Front Panel Sub Ass'y	1
	JA03515A	Chassis Ass'y 581 (220V Class 2)	1	L01	0E00793A	BT Screw M2x6 Philips Pan Head	5
	JA03622A	Chassis Ass'y 581 (Australia)	1	L02	0E00840A	BT Screw M2x8 Philips Pan Head	1
L01	0E00877A	ST Screw M3x5 Philips Binding Head	6	L03	0E00100A	Washer 2mm	1
				L04	0E00873A	BT Screw M2.6x5 Philips Binding Head	3
				L05	0E00841A	BT Screw M2x4 Philips Pan Head	4
				L06	0E00794A	BT Screw M2x5 Philips Pan Head	3

8.2. Synthesis Mechanism 581 (A01)

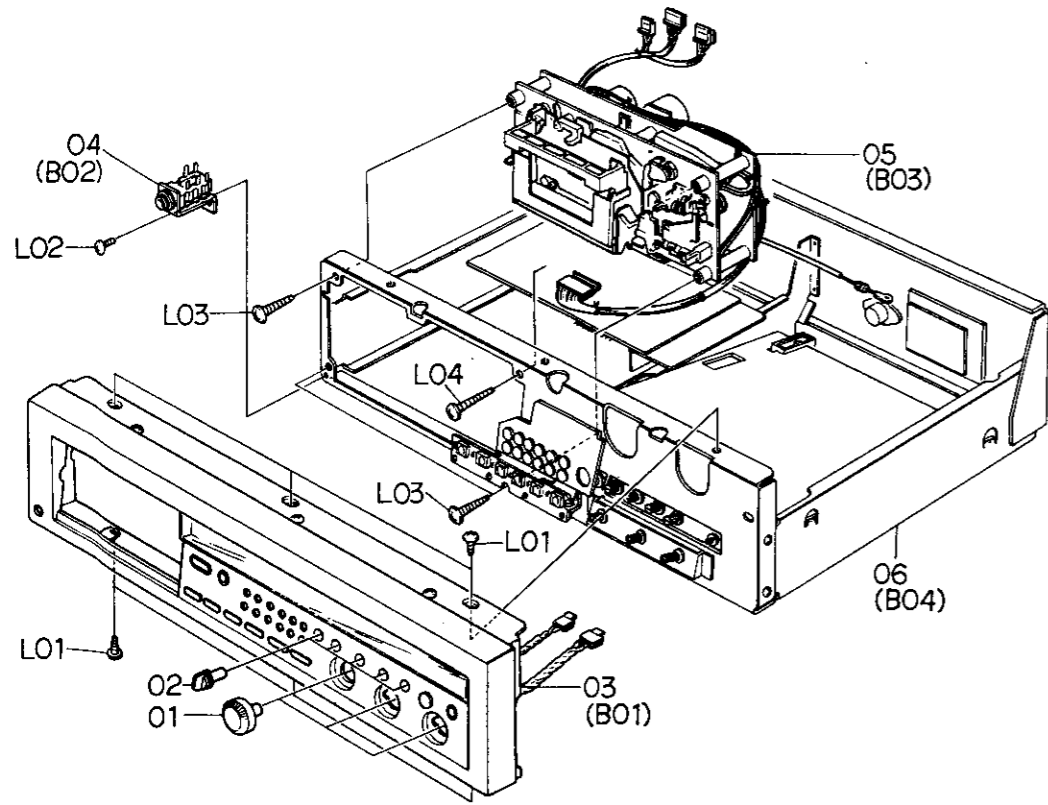

Fig. 8.2

8.3. Front Panel Ass'y 581 (B01)

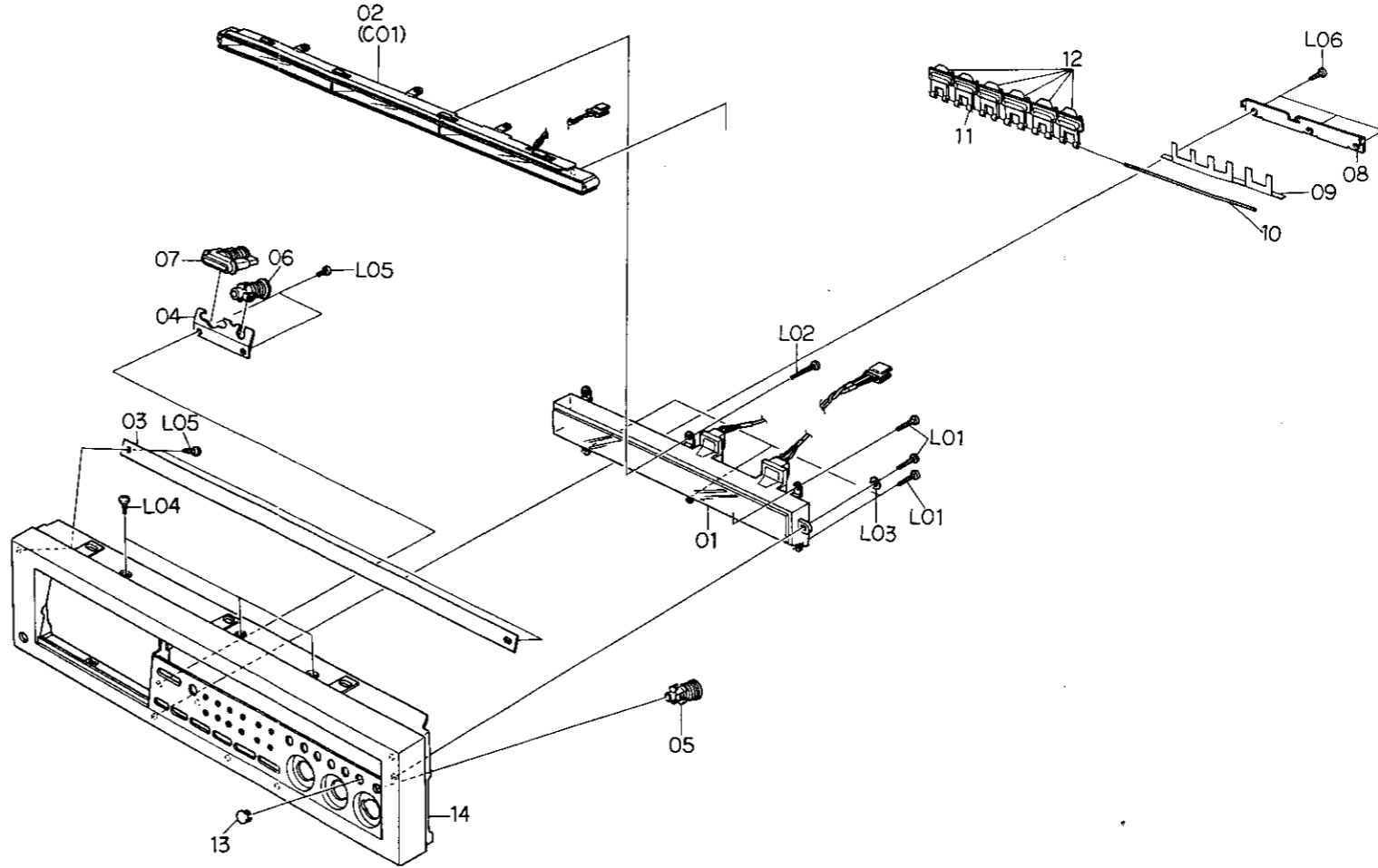

Fig. 8.3

8.4. Headphone Jack Ass'y (B02)

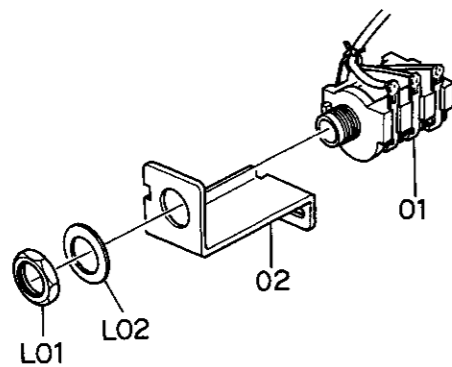

Fig. 8.4

Schematic Ref. No.	Part No.	Description	Q'ty
B02	JA03390A	Headphone Jack Ass'y	1
01	0B08511A	Headphone Jack	1
02	0J03975A	Jack Holder	1
L01	-	Jack Nut	(1)
L02	-	Jack Washer	(1)

8.5. Mechanism Ass'y 581 (B03)

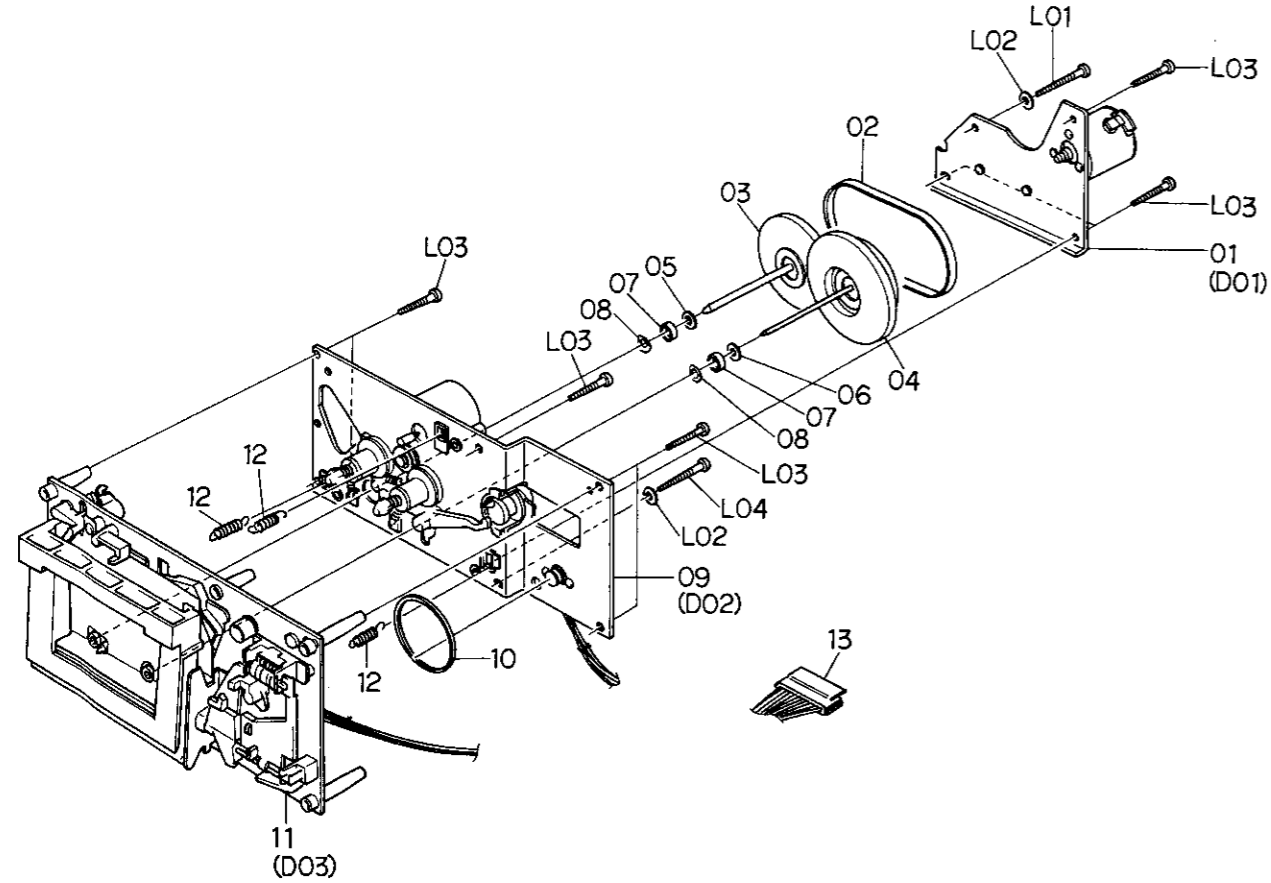

Fig. 8.5

8.6. Chassis Ass'y 581 (B04)

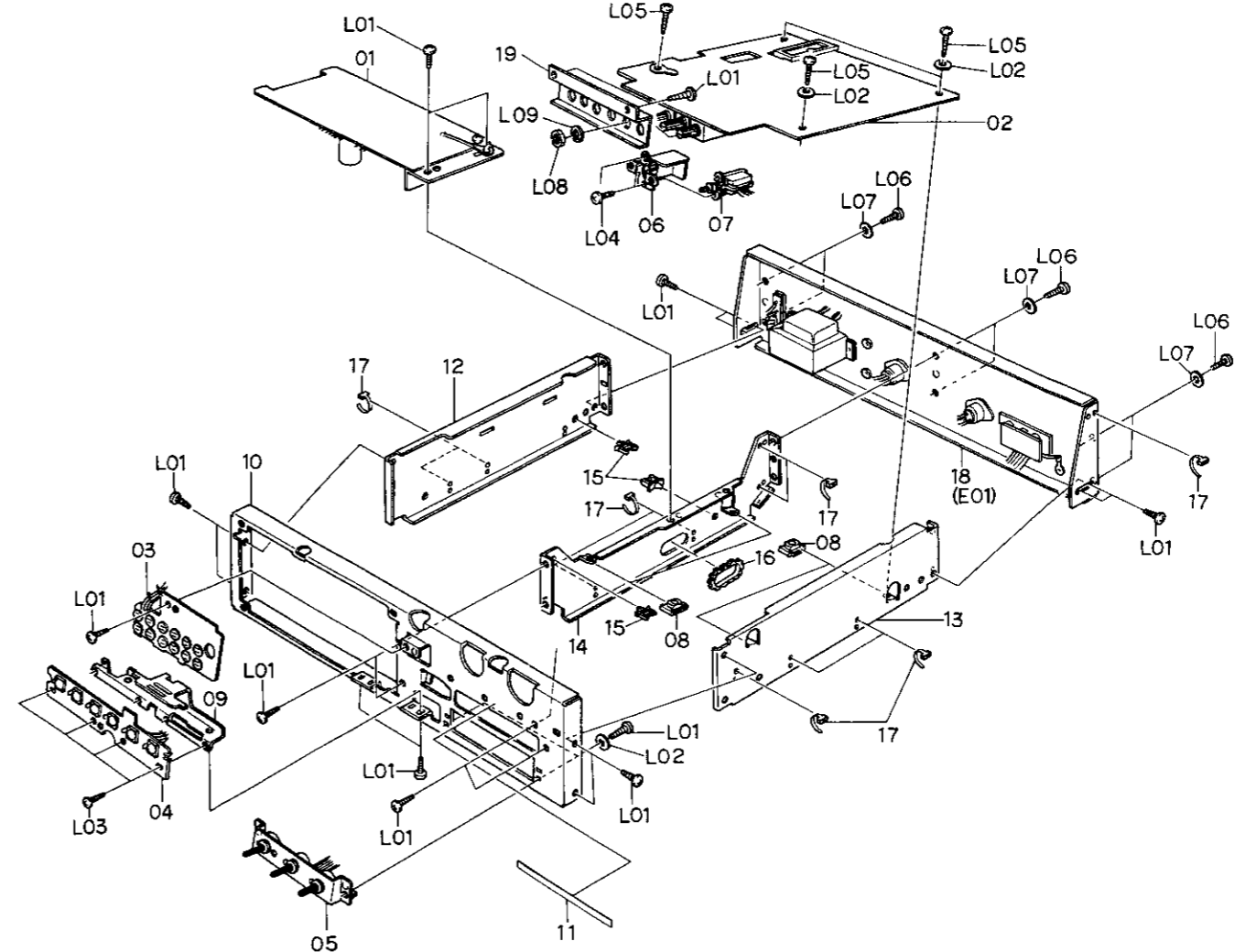

Fig. 8.6

Schematic Ref. No.	Part No.	Description	Q'ty
B03	CA08049B	Mechanism Ass'y 581	1
01	CA08017B	Flywheel Holder Ass'y	1
02	OC08096C	Capstan Belt	1
03	CA08014A	Supply Flywheel Ass'y	1
04	CA08015A	Take-up Flywheel Ass'y	1
05	OC08021B	Thrust Washer 3.1mm	1
06	OC08020B	Thrust Washer 2.6mm	1
07	OC08069C	Flange Thrust Cap	2
08	OC08022B	Flange Thrust Spring	2
09	CA08065A	Sub Mechanism Chassis Ass'y	1
10	OC08099B	Control Motor Belt	1
11	CA08077B	Main Mechanism Chassis Ass'y	1
12	OC08175A	Head Base L Spring	3
13	OB08578D	15P-H Connector	1
L01	0E00834A	BT Screw M3x30 Philips Pan Head	1
L02	0E00178A	Washer 3mm	2
L03	0E00833A	BT Screw M3x20 Philips Pan Head	8
L04	0E00835A	BT Screw M3x25 Philips Pan Head	1

Schematic Ref. No.	Part No.	Description	Q'ty
B04	JA03468B	Chassis Ass'y 581 (U.S.A. & Canada)	1
	JA03469B	Chassis Ass'y 581 (Japan)	1
	JA03471B	Chassis Ass'y 581 (Others)	1
	JA03473B	Chassis Ass'y 581 (UK)	1
	JA03515B	Chassis Ass'y 581 (220V Class 2)	1
	JA03622B	Chassis Ass'y 581 (Australia)	1
		Serial No.: A30206070 -	
01	BA04073B	Logic P.C.B. Ass'y (U.S.A., Japan, Canada & Others)	1
	BA04109B	Logic P.C.B. Ass'y (UK, Australia & 220V Class 2)	1
02	BA04015C	Main P.C.B. Ass'y	1
03	BA04014A	Record Cal. P.C.B. Ass'y	1
04	BA03976A	Control Switch P.C.B. Ass'y	1
05	BA04013A	Volume P.C.B. Ass'y	1
06	OJ04014A	Power Switch Holder	1

Schematic Ref. No.	Part No.	Description	Q'ty	Schematic Ref. No.	Part No.	Description	Q'ty
07	OB07253A	Power Switch (U.S.A., Canada & Others)	1		JA03517A	Rear Panel Ass'y (220V Class 2)	1
	OB07252A	Power Switch (UK & Australia)	1		JA03623A	Rear Panel Ass'y (Australia)	1
	OB07271A	Power Switch (Japan)	1	19	OJ04009C	Switch Holder	1
08	OJ04013C	P.C.B. Spacer	4	L01	0E00857A	BT Screw M3x6 Philips Binding Head	22
09	OJ03976B	Control Switch Holder	1	L02	0E00637A	Washer 3.3mm	5
10	OJ04012B	Front Chassis	1	L03	0E00859A	BT Screw M2.6x6 Philips Binding Head	4
11	OM04051B	Switch Label	1	L04	0E00502A	Screw M3x5 Philips Pan Head	2
12	OJ03969C	Side Chassis L	1	L05	0E00865A	BT Screw M3x10 Philips Binding Head	4
13	OJ03968D	Side Chassis R	1	L06	0E00860A	BT Screw M3x6 Philips Binding Head (Black)	6
14	OJ03970D	Center Chassis	1	L07	0E00157A	Washer 3mm (Black Plastics)	6
15	OB08580A	Wire Holder 161	3				
16	OB08590A	Free Bushing 80mm	1				
17	OB08515A	Insu-Lock	15				
18	JA03487A	Rear Panel Ass'y (U.S.A. & Canada)	1				
	JA03488A	Rear Panel Ass'y (Japan)	1				
	JA03490A	Rear Panel Ass'y (Others)	1				
	JA03492A	Rear Panel Ass'y (UK)	1				

Schematic Ref. No.	Part No.	Description	Q'ty	Schematic Ref. No.	Part No.	Description	Q'ty
B04	JA03468B	Chassis Ass'y 581 (U.S.A. & Canada)	1	B04	JA03468A	Chassis Ass'y 581 (U.S.A. & Canada)	1
	JA03469B	Chassis Ass'y 581 (Japan)	1		JA03469A	Chassis Ass'y 581 (Japan)	1
	JA03471B	Chassis Ass'y 581 (Others)	1		JA03471A	Chassis Ass'y 581 (Others)	1
	JA03473B	Chassis Ass'y 581 (UK)	1		JA03473A	Chassis Ass'y 581 (UK)	1
	JA03515B	Chassis Ass'y 581 (220V Class 2)	1		JA03515A	Chassis Ass'y 581 (220V Class 2)	1
	JA03622B	Chassis Ass'y 581 (Australia) Serial Nos.: A30205002 - A30206069	1		JA03622A	Chassis Ass'y 581 (Australia) Serial Nos.: A30201001 - A30205001	1
01	BA04073A	Logic P.C.B. Ass'y (U.S.A., Japan, Canada & Others)	1	01	BA04036A	Logic P.C.B. Ass'y (U.S.A., Japan, Canada & Others)	1
	BA04109A	Logic P.C.B. Ass'y (UK, Australia & 220V Class 2)	1		BA04040A	Logic P.C.B. Ass'y (UK, Australia & 220V Class 2)	1
02	BA04015B	Main P.C.B. Ass'y	1	02	BA04015B	Main P.C.B. Ass'y	1
03	BA04014A	Record Cal. P.C.B. Ass'y	1	03	BA04014A	Record Cal. P.C.B. Ass'y	1
04	BA03976A	Control Switch P.C.B. Ass'y	1	04	BA03976A	Control Switch P.C.B. Ass'y	1
05	BA04013A	Volume P.C.B. Ass'y	1	05	BA04013A	Volume P.C.B. Ass'y	1
06	OJ04014A	Power Switch Holder	1	06	OJ04014A	Power Switch Holder	1
07	OB07253A	Power Switch (U.S.A., Canada & Others)	1	07	OB07253A	Power Switch (U.S.A., Japan, Canada & Others)	1
	OB07252A	Power Switch (UK & Australia)	1		OB07252A	Power Switch (UK, Australia & 220V Class 2)	1
	OB07271A	Power Switch (Japan)	1				
08	OJ04013C	P.C.B. Spacer	4	08	OJ04013C	P.C.B. Spacer	4
09	OJ03976B	Control Switch Holder	1	09	OJ03976B	Control Switch Holder	1
10	OJ04012B	Front Chassis	1	10	OJ04012B	Front Chassis	1
11	OM04051B	Switch Label	1	11	OM04051B	Switch Label	1
12	OJ03969C	Side Chassis L	1	12	OJ03969C	Side Chassis L	1
13	OJ03968D	Side Chassis R	1	13	OJ03968D	Side Chassis R	1
14	OJ03970D	Center Chassis	1	14	OJ03970D	Center Chassis	1
15	OB08580A	Wire Holder 161	3	15	OB08580A	Wire Holder 161	3
16	OB08590A	Free Bushing 80mm	1	16	OB08590A	Free Bushing 80mm	1
17	OB08515A	Insu-Lock	15	17	OB08515A	Insu-Lock	15
18	JA03487A	Rear Panel Ass'y (U.S.A. & Canada)	1	18	JA03487A	Rear Panel Ass'y (U.S.A. & Canada)	1
	JA03488A	Rear Panel Ass'y (Japan)	1		JA03488A	Rear Panel Ass'y (Japan)	1
	JA03490A	Rear Panel Ass'y (Others)	1		JA03490A	Rear Panel Ass'y (Others)	1
	JA03492A	Rear Panel Ass'y (UK)	1		JA03492A	Rear Panel Ass'y (UK)	1
	JA03517A	Rear Panel Ass'y (220V Class 2)	1		JA03517A	Rear Panel Ass'y (220V Class 2)	1
	JA03623A	Rear Panel Ass'y (Australia)	1		JA03623A	Rear Panel Ass'y (Australia)	1
19	OJ04009C	Switch Holder	1	19	OJ04009C	Switch Holder	1
L01	OE00857A	BT Screw M3x6 Philips Binding Head	22	L01	OE00857A	BT Screw M3x6 Philips Binding Head	22
L02	OE00637A	Washer 3.3mm	5	L02	OE00637A	Washer 3.3mm	5
L03	OE00859A	BT Screw M2.6x6 Philips Binding Head	4	L03	OE00859A	BT Screw M2.6x6 Philips Binding Head	4
L04	OE00502A	Screw M3x5 Philips Pan Head	2	L04	OE00502A	Screw M3x5 Philips Pan Head	2
L05	OE00865A	BT Screw M3x10 Philips Binding Head	4	L05	OE00865A	BT Screw M3x10 Philips Binding Head	4
L06	OE00860A	BT Screw M3x6 Philips Binding Head (Black)	6	L06	OE00860A	BT Screw M3x6 Philips Binding Head (Black)	6
L07	OE00157A	Washer 3mm (Black Plastics)	6	L07	OE00157A	Washer 3mm (Black Plastics)	6

Schematic Ref. No.	Part No.	Description	Q'ty
C01	HA03777A	Lamp House Cover Ass'y	1
01	0J03977B	Lamp House Cover Holder	1
02	BA03974A	Lamp P.C.B. Ass'y	1
03	0H03673A	Lamp House Cover	1
04	0H03674D	Lamp House	3
L01	0E00853A	BT Screw M2x3 Philips Pan Head	2
L02	0E00793A	BT Screw M2x6 Philips Binding Head	2
D01	CA08017B	Flywheel Holder Ass'y	1
01	0C08013I	Flywheel Holder	1
02	0C08135A	Capstan Motor	1
03	0C08079F	Capstan Motor Pulley	1
L01	0E00226A	Screw M2.6x4 Philips Pan Head	3
L02	0E00626A	Screw M2x3 Cup Point	1
L03	0C08068C	Thrust Screw	2
L04	0C03857A	Lock Nut	2
D02	CA08065A	Sub Mechanism Chassis Ass'y	1
01	0C08039A	Reel Hub Head	2
02	CA08038B	Reel Hub B Ass'y	2
03	CA08037A	Reel Hub Take-up Ass'y	1
04	CA08064A	Reel Hub Supply Ass'y	1
05	CA08039A	Back Tension Ass'y	1
06	0C08178A	Back Tension Spring	1
07	CA08040A	Idler Ass'y	1
08	0C08127B	Idler Arm Spring	1
09	CA08042A	Brake Arm Ass'y	2
10	0C08030C	Brake Drive Arm	1
11	0C08129A	Brake Arm Spring	1
12	0C08128A	Brake Drive Arm Spring	1
13	0B04042A	Lug Terminal 1L2P	1
14	0B09091A	Ceramic Capacitor 0.01 μ 50V	2
15	CA08036A	Reel Motor Ass'y	1
16	CA08034A	Control Motor Ass'y	1
17	0C08053B	Volume Coupler	1
18	0B07240A	Volume Control 10K Ω (B)	1
19	CA08041A	Sub Chassis Ass'y	1
L01	0E00842A	Stopper Ring 2mm	1
L02	0E00837A	Stopper Ring 3mm	2
L03	0E00838A	Stopper Ring 4mm	1
L04	0E00859A	BT Screw M2.6x6 Philips Binding Head	1
L05	0E00226A	Screw M2.6x4 Philips Pan Head	5
L06	0E00843A	BT Screw M3x5 Philips Pan Head	1
L07	-	Volume Nut	(1)
L08	-	Volume Washer	(1)

8.7. Lamp House Cover Ass'y (C01)

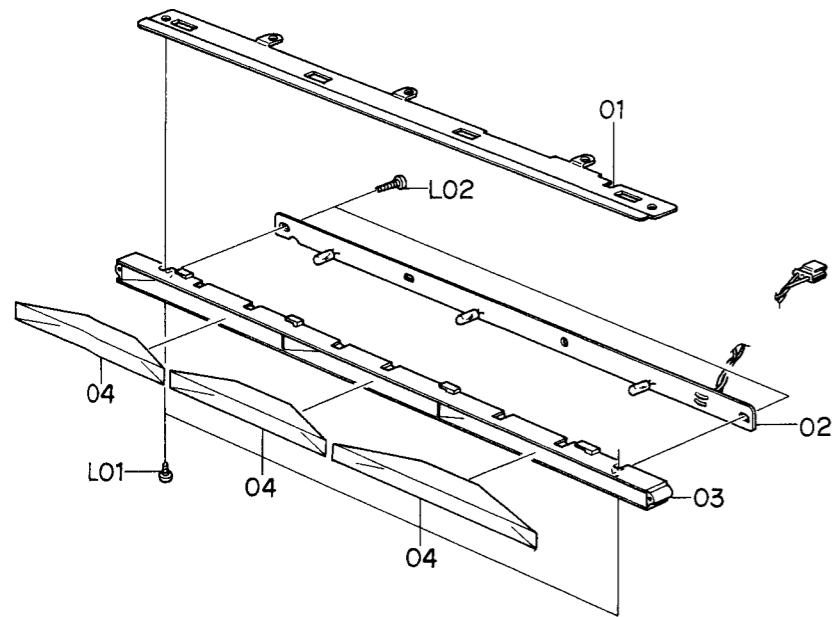

Fig. 8.7

8.8. Flywheel Holder Ass'y (D01)

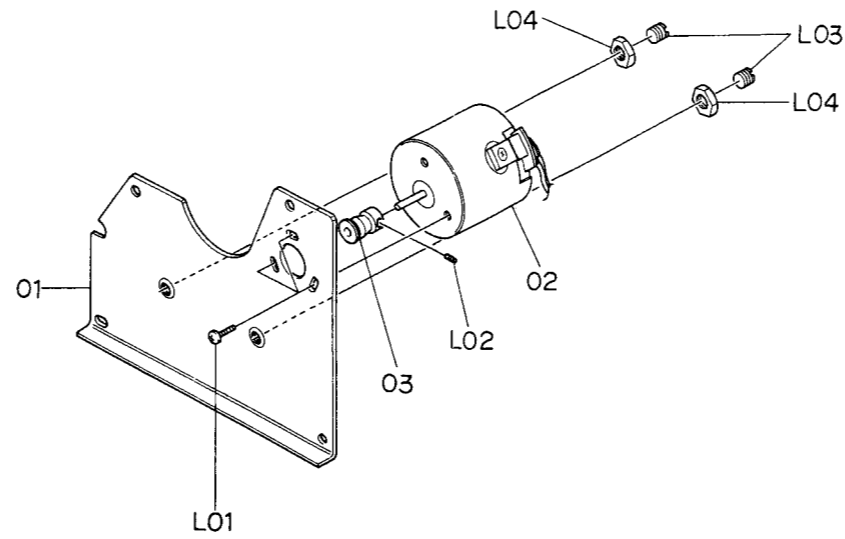

Fig. 8.8

8.9. Sub Mechanism Chassis Ass'y (D02)

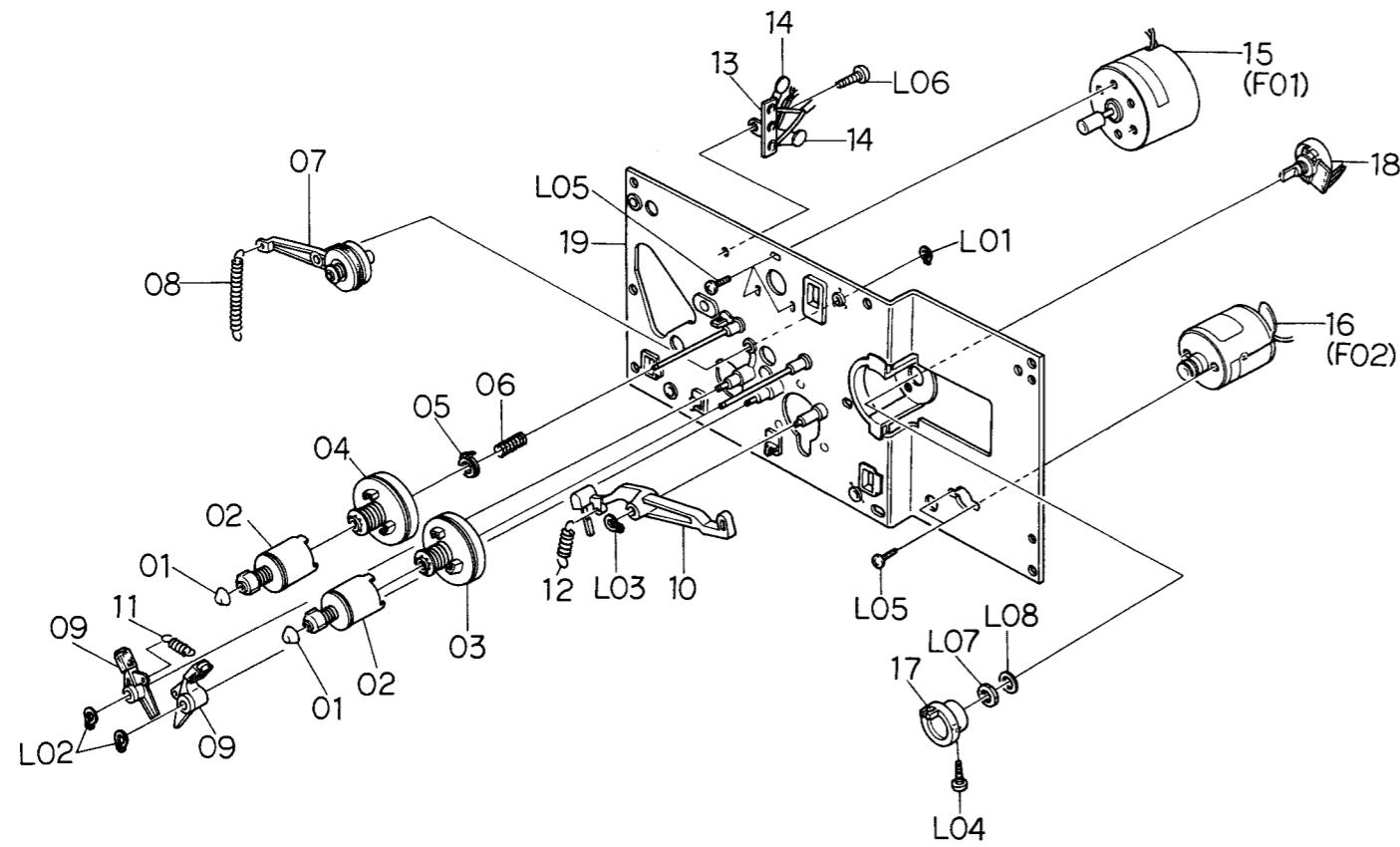

Fig. 8.9

8.10. Main Mechanism Chassis Ass'y (D03)

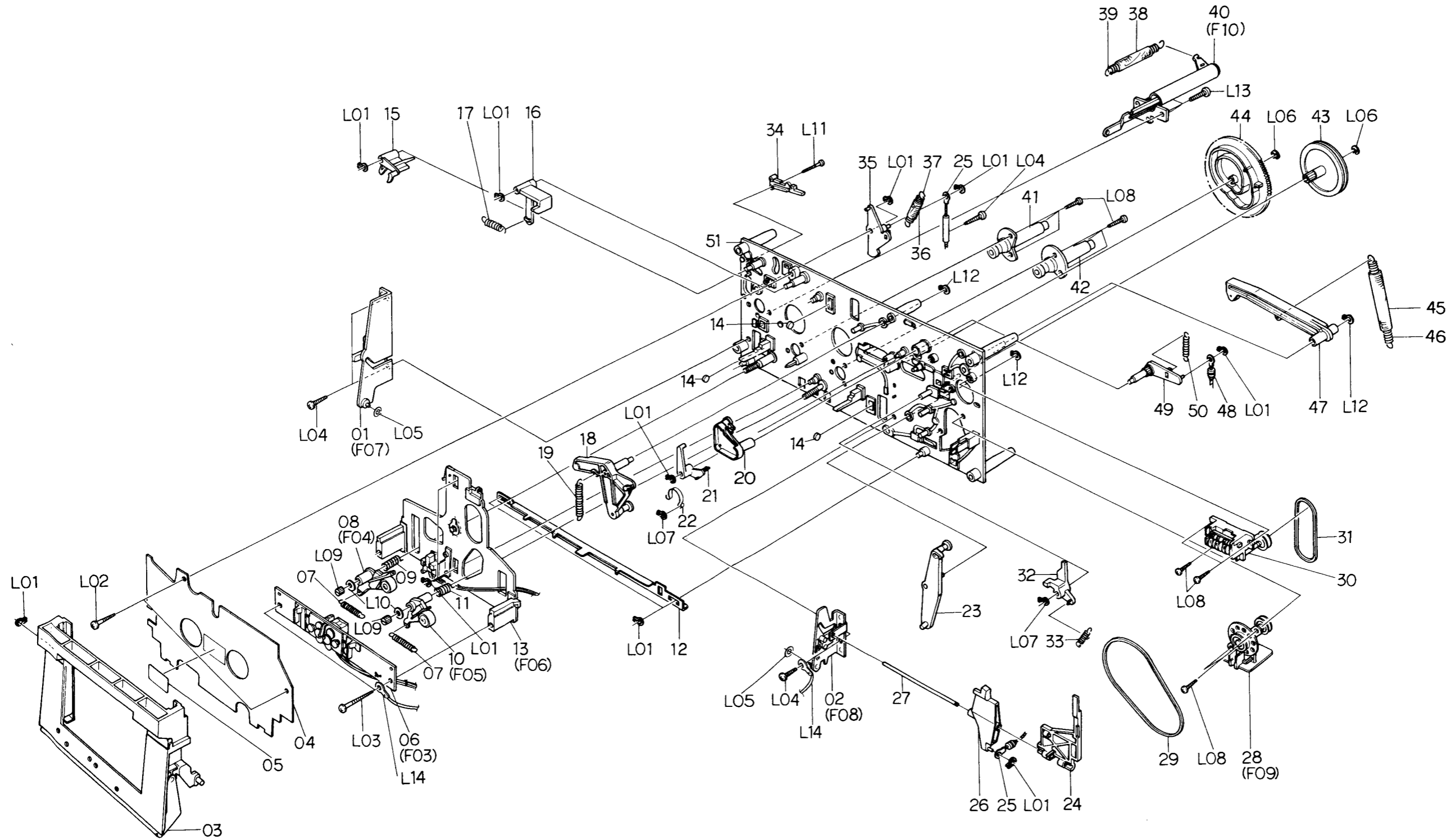

Fig. 8.10



Schematic Ref. No.	Part No.	Description	Q'ty	Schematic Ref. No.	Part No.	Description	Q'ty	Schematic Ref. No.	Part No.	Description	Q'ty
D03	CA08077B	Main Mechanism Chassis Ass'y Serial No.: A30206790 -	1	L05	0E00254A	Washer 3.1mm (Plastics)	2	44	0C08029H	Control Cam	1
				L06	0E00222A	E-Ring 2mm	2	45	0C08117A	Counter-Load Arm Spring	1
				L07	0E00839A	Stopper Ring 2.5mm	2	46	0C08152A	Counter-Load Arm Spring Tube	1
01	CA08048A	Cassette Case Holder L Ass'y	1	L08	0E00876A	BT Screw M2.6x8 Philips Pan Head	11	47	CA08028A	Counter-Load Arm Ass'y	1
02	CA08022A	Cassette Case Holder R Ass'y	1					48	0C08123A	Record Switch Linkage Wire	1
03	CA08055A	Cassette Case Ass'y	1	L09	0C08060B	Height Adjustment Nut	2	49	0C08037E	Record Arm B	1
04	0C08019I	Cover Plate	1	L10	0E00142A	Washer 2.6mm	2	50	0C08116A	Record Arm Spring	1
05	0M03977A	Cassette Viewer Label	1	L11	0E00879A	BT Screw M2x15 Philips Pan Head	1	51	CA08072A	Main Chassis Ass'y	1
06	CA08056C	Head Mount Base Ass'y	1					L01	0E00837A	Stopper Ring 3mm	13
07	0C08121A	Supply Pressure Roller Spring	2	L12	0E00838A	Stopper Ring 4mm	3	L02	0E00832A	BT Screw M3x14 Philips Pan Head	2
08	CA08053B	Supply Pressure Roller Ass'y	1	L13	0E00846A	BT Screw M3x8 Philips Pan Head	3	L03	0E00834A	BT Screw M3x30 Philips Pan Head	2
09	0C08122B	Supply Pressure Roller Thrust Spring	1	L14	0E00895A	Earth Lug 3mm	2	L04	0E00831A	BT Screw M3x10 Philips Pan Head	4
10	CA08079A	Take-up Pressure Roller Ass'y	1								
11	0C08183B	Take-up Pressure Roller Thrust Spring	1	D03	CA08077A	Main Mechanism Chassis Ass'y Serial Nos.: A30201001 - A30206789	1	L05	0E00254A	Washer 3.1mm (Plastics)	2
12	0C08182A	Pressure Roller Drive Bar B	1					L06	0E00222A	E-Ring 2mm	2
13	CA08129A	Head Base Ass'y B	1	01	CA08048A	Cassette Case Holder L Ass'y	1	L07	0E00839A	Stopper Ring 2.5mm	2
14	0C08086B	Head Base Roller	3	02	CA08022A	Cassette Case Holder R Ass'y	1	L08	0E00876A	BT Screw M2.6x8 Philips Pan Head	11
15	0C08050B	Record Sensor	1	03	CA08055A	Cassette Case Ass'y	1	L09	0C08060B	Height Adjustment Nut	2
16	0C08051E	Cassette Hold Arm	1	04	0C08019I	Cover Plate	1	L10	0E00142A	Washer 2.6mm	2
17	0C08120A	Cassette Hold Arm Spring	1	05	0M03977A	Cassette Viewer Label	1	L11	0E00879A	BT Screw M2x15 Philips Pan Head	1
18	CA08027A	Head Base Drive Arm Ass'y	1	06	CA08056C	Head Mount Base Ass'y	1				
19	0C08143C	Head Base Drive Arm Spring	1	07	0C08121A	Supply Pressure Roller Spring	2	L12	0E00838A	Stopper Ring 4mm	3
20	CA08025A	Record Arm Ass'y	1	08	CA08053B	Supply Pressure Roller Ass'y	1	L13	0E00846A	BT Screw M3x8 Philips Pan Head	3
21	0C08038D	Record Trigger	1	09	0C08122B	Supply Pressure Roller Thrust Spring	1	L14	0E00895A	Earth Lug 3mm	2
22	0C08112A	Flip-Flop Spring	1								
23	CA08026A	Pressure Roller Drive Arm Ass'y	1	10	CA08079A	Take-up Pressure Roller Ass'y	1				
24	0C08071C	Counter Reset Arm	1	11	0C08183B	Take-up Pressure Roller Thrust Spring	1				
25	0C08124B	Eject Linkage Wire	1								
26	0C08057E	Eject Arm	1	12	0C08182A	Pressure Roller Drive Bar B	1				
27	0C08078B	Arm Shaft	1	13	CA08129A	Head Base Ass'y B	1				
28	CA08032B	Auto Shut-off Ass'y	1	14	0C08086B	Head Base Roller	3				
29	0C08097B	Counter Belt A	1	15	0C08050B	Record Sensor	1				
30	CA08020A	Counter Ass'y	1	16	0C08051E	Cassette Hold Arm	1				
31	0C08098B	Counter Belt B	1	17	0C08120A	Cassette Hold Arm Spring	1				
32	0C08067C	Eject Stopper	1	18	CA08027A	Head Base Drive Arm Ass'y	1				
33	0C08134C	Eject Stopper Spring	1	19	0C08143C	Head Base Drive Arm Spring	1				
34	0C08119A	Record Protector	1	20	CA08025A	Record Arm Ass'y	1				
35	0C08052H	Damper Lock Arm	1	21	0C08038D	Record Trigger	1				
36	0C08153A	Damper Arm Spring Tube	1	22	0C08112A	Flip-Flop Spring	1				
37	0C08125A	Damper Arm Spring	1	23	CA08026A	Pressure Roller Drive Arm Ass'y	1				
38	0C08151A	Lid Arm Spring Tube	1	24	0C08071C	Counter Reset Arm	1				
39	0C08114A	Lid Arm Spring	1	25	0C08124B	Eject Linkage Wire	1				
40	CA08030A	Pneumatic Damper Ass'y	1	26	0C08057E	Eject Arm	1				
41	CA08023A	Supply Capstan Flange Ass'y	1	27	0C08078B	Arm Shaft	1				
42	CA08024A	Take-up Capstan Flange Ass'y	1	28	CA08032A	Auto Shut-off Ass'y	1				
43	0C08065D	Cam Drive Gear	1	29	0C08097B	Counter Belt A	1				
44	0C08029H	Control Cam	1	30	CA08020A	Counter Ass'y	1				
45	0C08117A	Counter-Load Arm Spring	1	31	0C08098B	Counter Belt B	1				
46	0C08152A	Counter-Load Arm Spring Tube	1	32	0C08067C	Eject Stopper	1				
47	CA08028A	Counter-Load Arm Ass'y	1	33	0C08134C	Eject Stopper Spring	1				
48	0C08123A	Record Switch Linkage Wire	1	34	0C08119A	Record Protector	1				
49	0C08037E	Record Arm B	1	35	0C08052H	Damper Lock Arm	1				
50	0C08116A	Record Arm Spring	1	36	0C08153A	Damper Arm Spring Tube	1				
51	CA08072A	Main Chassis Ass'y	1	37	0C08125A	Damper Arm Spring	1				
L01	0E00837A	Stopper Ring 3mm	13	38	0C08151A	Lid Arm Spring Tube	1				
L02	0E00832A	BT Screw M3x14 Philips Pan Head	2	39	0C08114A	Lid Arm Spring	1				
L03	0E00834A	BT Screw M3x30 Philips Pan Head	2	40	CA08030A	Pneumatic Damper Ass'y	1				
L04	0E00831A	BT Screw M3x10 Philips Pan Head	4	41	CA08023A	Supply Capstan Flange Ass'y	1				
				42	CA08024A	Take-up Capstan Flange Ass'y	1				
				43	0C08065D	Cam Drive Gear	1				

8.11. Rear Panel Ass'y (E01)

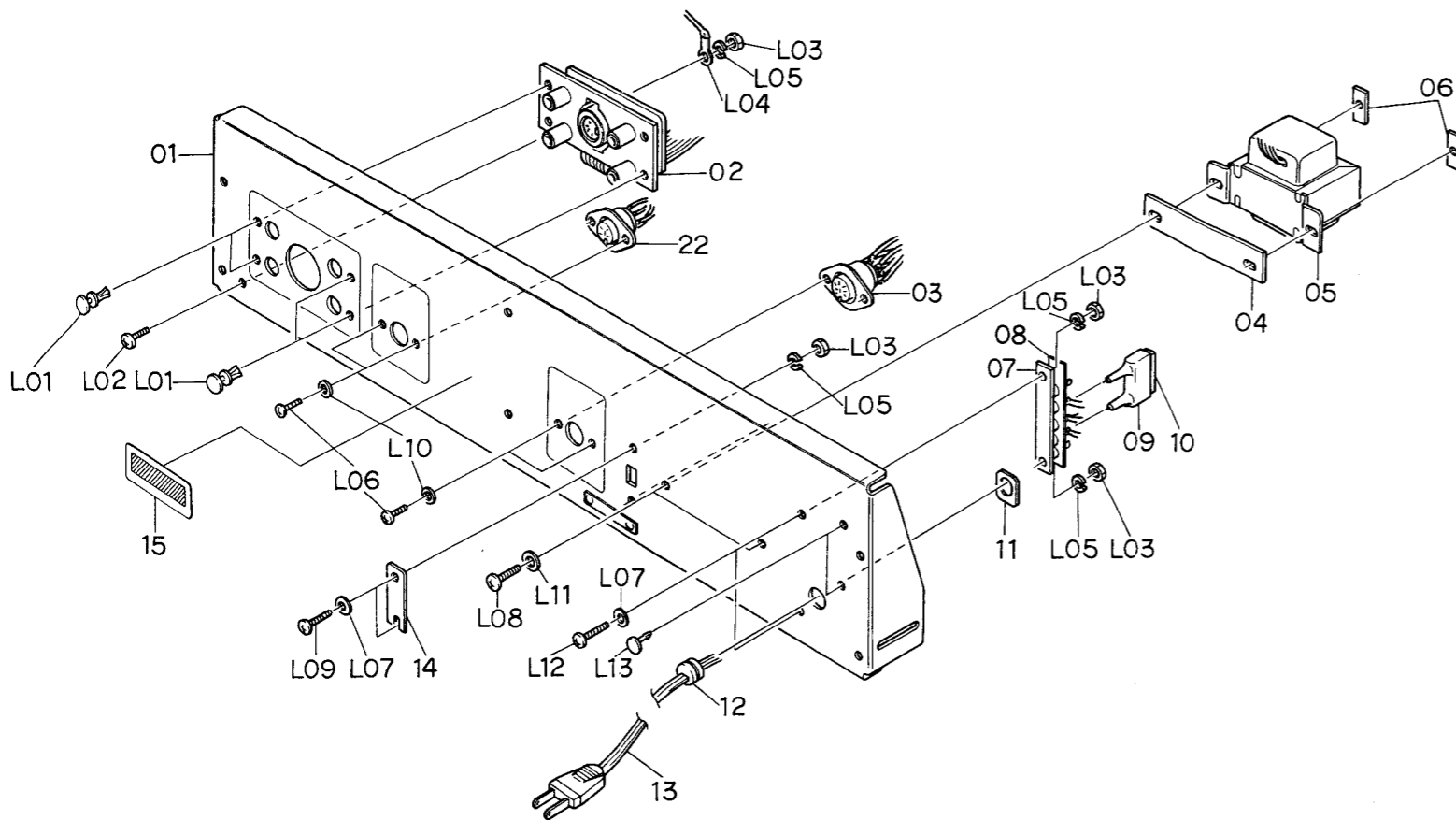
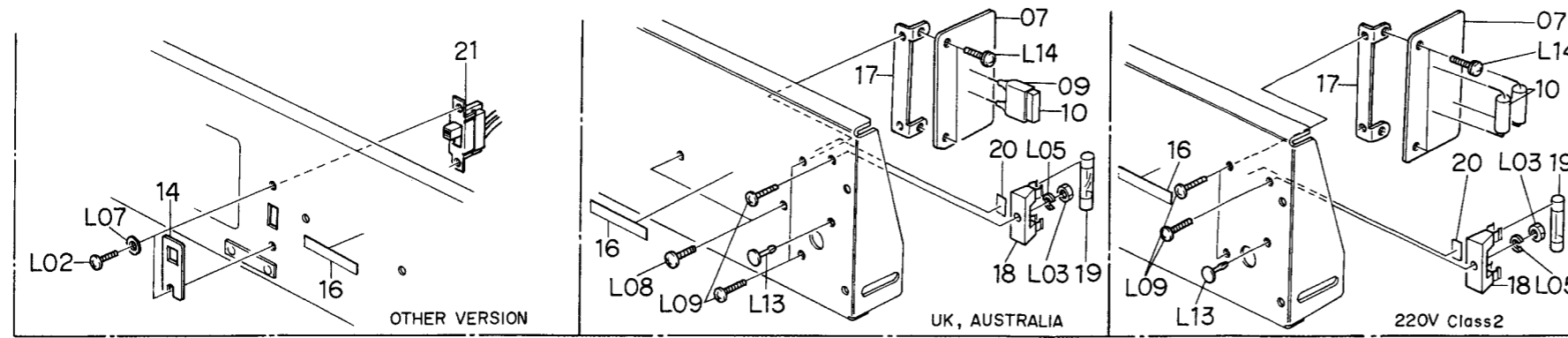

Fig. 8.11

Schematic Ref. No.	Part No.	Description	Q'ty
E01	JA03487A	Rear Panel Ass'y (U.S.A. & Canada)	1
	JA03488A	Rear Panel Ass'y (Japan)	1
	JA03490A	Rear Panel Ass'y (Others)	1
	JA03492A	Rear Panel Ass'y (UK)	1
	JA03517A	Rear Panel Ass'y (220V Class 2)	1
	JA03623A	Rear Panel Ass'y (Australia)	1
01	0J04010D	Rear Panel	1
02	BA04031A	DIN-Pin P.C.B. Ass'y	1
03	0B08584A	8P DIN Socket	1
04	0J04016A	Transformer Plate	1
05	0B06609A	Power Transformer (U.S.A. & Canada)	1
	0B06610A	Power Transformer (Japan)	1
	0B06611A	Power Transformer (Others)	1
	0B06612A	Power Transformer (UK, Australia & 220V Class 2)	1
06	0C01162B	Bolt Receptacle Plate	2
07	0B08025U	5P Terminal Strip (U.S.A., Canada, Japan & Others)	1
	0B07817A	Terminal P.C.B. C (UK, Australia & 220V Class 2)	1
08	0B08555A	5P Terminal Insulator 08 (U.S.A., Canada, Japan & Others)	1
09	0B08359A	Spark Killer Cover (U.S.A., Canada, Japan & Others)	1
10	0B08342A	Spark Killer (U.S.A. & Canada)	1
	0B08363A	Spark Killer (Japan)	1
	0B08240U	Spark Killer (UK, Australia & Others)	1
	0B08445A	Spark Killer (220V Class 2)	1
11	0A03154B	Cord Spacer	1
12	0B08037U	Cord Bushing C (U.S.A., Canada, Japan, 220V Class 2 & Others)	1
	0B08351A	Cord Bushing 4K-4 (UK)	1
13	0B08325U	Cord Bushing E (Australia)	1
	0B08533A	Power Cord (U.S.A., Canada & Others)	1
14	0B08219B	Power Cord (Japan)	1
	0B08348A	Power Cord (UK)	1
	0B08093A	Power Cord (220V Class 2)	1
	0B08666A	Power Cord (Australia)	1
	0J03663A	Switch Cover (U.S.A., Canada, Japan, UK, Australia & 220V Class 2)	1
	0M03946A	Voltage Selector Lock Plate C (Others)	1
15	0M03458A	Pass Label	1
16	0M03794A	Voltage Label 100V (Japan)	1
	0M03796A	Voltage Label 220V (220V Class 2)	1
	0M03797A	Voltage Label 240V (UK & Australia)	1
	0M03955A	Voltage Label 120V/220-240V (Others)	1
17	0J03893A	Terminal P.C.B. Holder B (UK, Australia & 220V Class 2)	1
18	0B08048A	Fuse Holder (UK, Australia & 220V Class 2)	1
19	0B08344A	Fuse 200mA T, 250V (UK, Australia & 220V Class 2)	1
20	0M03968A	Fuse Label 200mA T (UK, Australia & 220V Class 2)	1

Schematic Ref. No.	Part No.	Description	Q'ty
21	0B07092U	Voltage Selector (Others)	1
22	0B08355A	4P DIN Socket	1
—	0M03844B	Power Cord Label (UK & Australia)	1
—	0F01071A	Free-up Belt	1
—	0M03996A	Serial Number Plate	1
—	0M03798A	Nakamichi Label (Japan)	1
—	0M04055A	SDNF Label (220V Class 2)	1
—	0M03865A	SEV Label (220V Class 2)	1
—	0M03697A	Rating Label (220V Class 2)	1
L01	0B08539A	Plastic Rivet	4
L02	0E00593A	Screw M3x6 Philips Binding Head (Bronze)	3
L03	0E00507A	Nut 3mm	6
L04	0E00037A	Earth Lug B-5	1
L05	0E00581A	Washer 3mm Spring	6
L06	0E00714A	Screw M2.6x6 Philips Binding Head (Bronze)	4
L07	0E00157A	Washer 3mm (Black Plastics)	2
L08	0E00756A	Screw M4x8 Philips Binding Head (Bronze)	5
L09	0E00594A	Screw M3x8 Philips Binding Head (Bronze)	4
L10	0E00651A	Washer 2.6mm (Black Plastics)	2
L11	0E00645A	Washer 4mm (Black Plastics)	2
L12	0E00701A	Screw M3x10 Philips Binding Head (Bronze)	2
L13	0B08583A	Plastic Clip	2
L14	0E00510A	Screw M3x8 Philips Pan Head (2A)	2
—	0J03644A	Chobert Rivet	2
F01	CA08036A	Reel Motor Ass'y	1
01	0C08138A	Reel Motor	1
02	0C08063E	Reel Motor Pulley	1
03	0M03902A	Motor Level 730	1
04	0M03987A	Motor Seal A	1
L01	0E00672A	Screw M2x2 Cup Point	1
F02	CA08034A	Control Motor Ass'y	1
01	0C08137A	Control Motor	1
02	0C08064A	Control Motor Pulley	1
03	0B01356A	Ceramic Capacitor 0.1μ 50V	1
04	0M03985A	Control Motor Label	1
05	0M03988A	Motor Seal B	1
F03	CA08056C	Head Mount Base Ass'y	1
01	0C08028C	Head Height Adjustment Gear	2
02	0C08027E	Head Height Adjustment Screw	4
03	0C08026D	Azimuth Alignment Screw	2
04	0C08161B	Spring Stopper	2
05	0C08187B	Head Plate Spring	2
06	CA08083C	Head Mount Base Sub Ass'y	1
07	CA08127A	P-8L Playback Head Ass'y	1
08	CA08128A	R-8L Record Head Ass'y	1

8.12. Reel Motor Ass'y (F01)

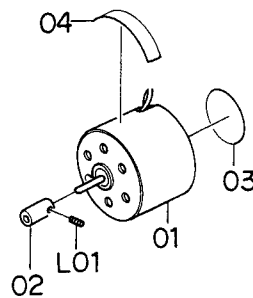

Fig. 8.12

8.13. Control Motor Ass'y (F02)

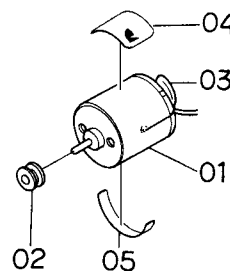

Fig. 8.13

8.14. Head Mount Base Ass'y (F03)

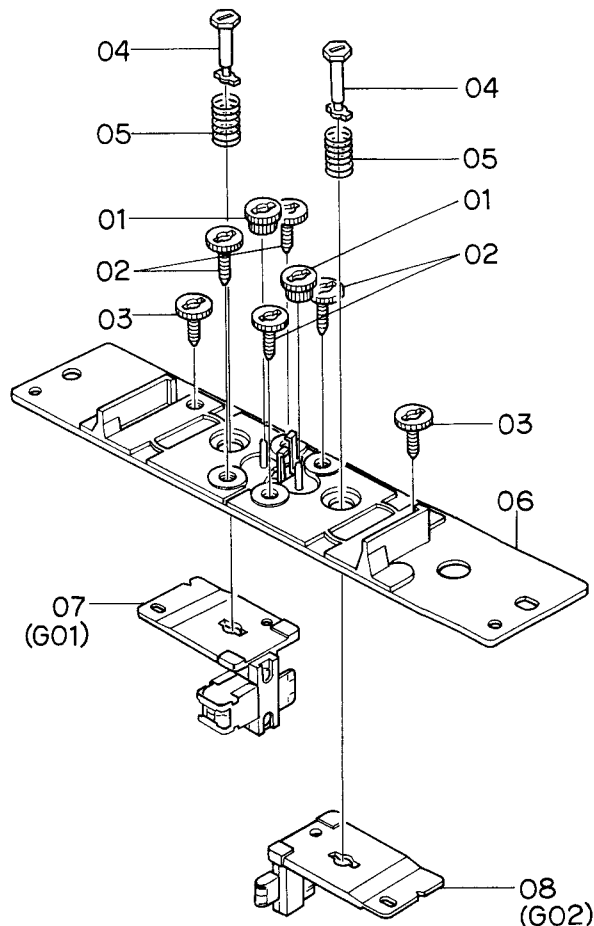

Fig. 8.14

8.15. Supply Pressure Roller Ass'y (F04)

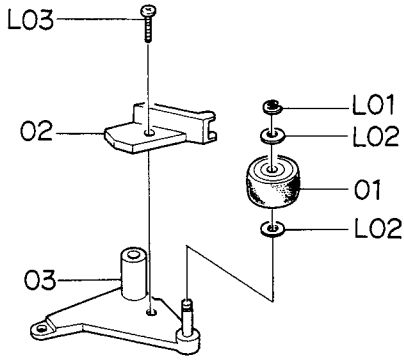

Fig. 8.15

8.16. Take-up Pressure Roller Ass'y (F05)

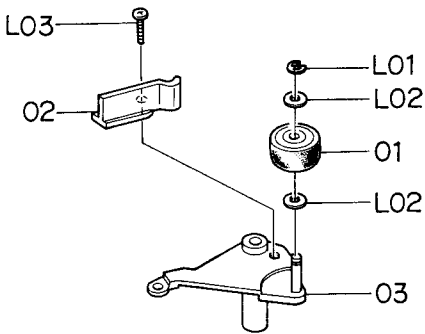

Fig. 8.16

8.17. Head Base Ass'y B (F06)

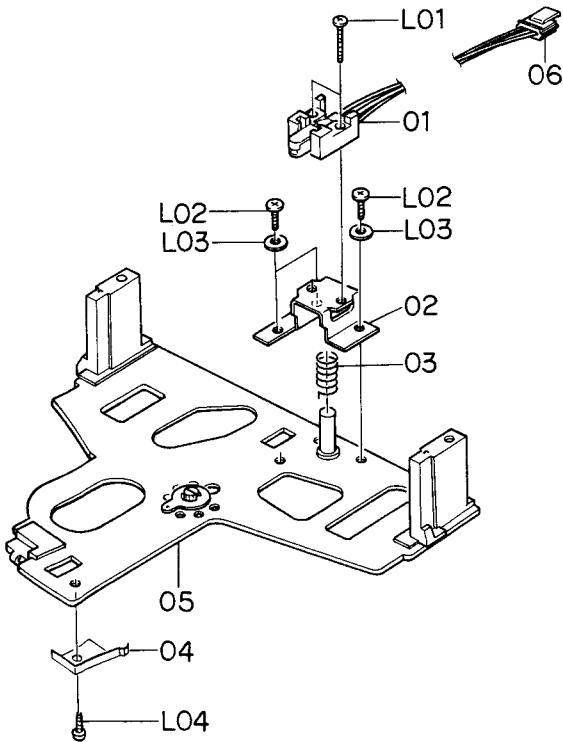

Fig. 8.17

8.18. Cassette Case Holder L Ass'y (F07)

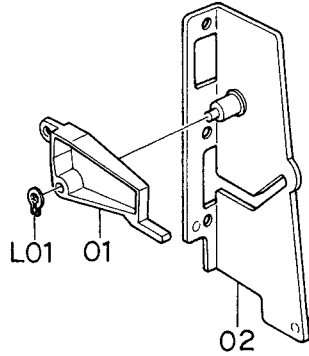

Fig. 8.18

8.19. Cassette Case Holder R Ass'y (F08)

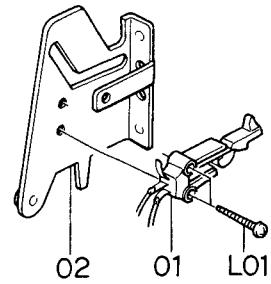

Fig. 8.19

8.20. Auto Shut-off Ass'y (F09)

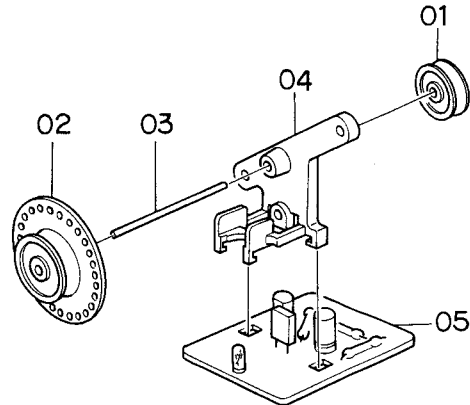

Fig. 8.20.1 Serial No.: A30206790 -

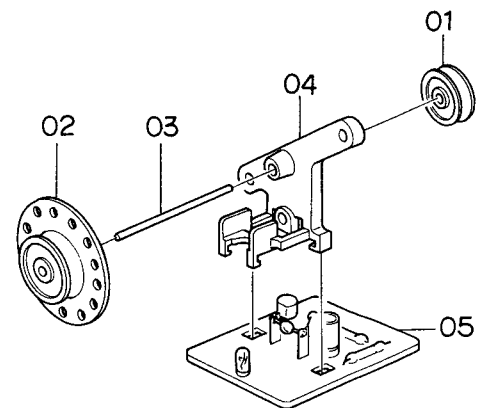

Fig. 8.20.2
Serial Nos.: A30201001 - A30206789

8.21. Pneumatic Damper Ass'y (F10)

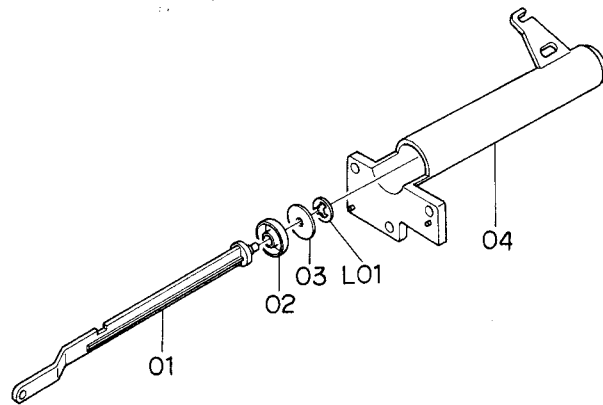

Fig. 8.21

Schematic Ref. No.	Part No.	Description	Q'ty	Schematic Ref. No.	Part No.	Description	Q'ty
F04	CA08053B	Supply Pressure Roller Ass'y	1	F08	CA08022A	Cassette Case Holder R Ass'y	1
01	0C08164E	Pressure Roller	1	01	0C08133A	Eject Sensor	1
02	0C08189B	Supply Tape Guide	1	02	CA08044A	Cassette Case Holder R Sub Ass'y	1
03	CA08061A	Supply Pressure Roller Arm Ass'y	1	L01	0E00840A	BT Screw M2x8 Philips Pan Head	2
L01	0E00042A	E-Ring 1.5mm	1	F09	CA08032B	Auto Shut-off Ass'y Serial No.: A30206790 —	1
L02	0C08024A	Washer 2mm	2	01	0C08206B	Shut-off Pulley B	1
L03	0E00788A	BT Screw M2x8 Philips Pan Head	1	02	0C08047A	Shut-off Pulley A	1
F05	CA08079A	Take-up Pressure Roller Ass'y	1	03	0C08088B	Shut-off Pulley Shaft	1
01	0C08164E	Pressure Roller	1	04	0C08207B	Shut-off Pulley Holder	1
02	0C08181B	Take-up Tape Guide	1	05	BA04076A	Shut-off P.C.B. Ass'y	1
03	CA08073B	Take-up Pressure Roller Arm Ass'y	1	F09	CA08032A	Auto Shut-off Ass'y Serial Nos.: A30201001 — A30206789	1
L01	0E00042A	E-Ring 1.5mm	1	01	0C08048A	Shut-off Pulley B	1
L02	0C08024A	Washer 2mm	2	02	0C08047A	Shut-off Pulley A	1
L03	0E00788A	BT Screw M2x8 Philips Pan Head	1	03	0C08088B	Shut-off Pulley Shaft	1
F06	CA08129A	Head Base Ass'y B	1	04	0C08046A	Shut-off Pulley Holder	1
01	GA02017A	Erase Head E-8L	1	05	BA03975A	Shut-off P.C.B. Ass'y	1
02	0C08158C	EH Hold Plate	1	F10	CA08030A	Pneumatic Damper Ass'y	1
03	0C08166A	EH Hold Plate Spring	1	01	0C08058C	Damper Piston	1
04	0C08174C	Cassette Hold Spring	1	02	0C08102B	Damper Ring	1
05	CA08003P	Head Base Ass'y	1	03	0C08010C	Damper Plate	1
06	0B08620C	3P-H Connector	1	04	0C08059E	Sylinder	1
L01	0E00889A	Screw M1.7x8 Philips Pan Head	2	L01	0E00874A	Stopper Ring CS 2mm	1
L02	0E00185A	Screw M2x6 Cylinder Head	3				
L03	0E00117A	Washer 2mm	3				
L04	0E00794A	BT Screw M2x5 Philips Pan Head	1				
F07	CA08048A	Cassette Case Holder L Ass'y	1				
01	0C08073C	Lid Arm A	1				
02	CA08035A	Cassette Case Holder L Sub Ass'y	1				
L01	0E00837A	Stopper Ring 3mm	1				

8.22. P-8L Playback Head Ass'y (G01)

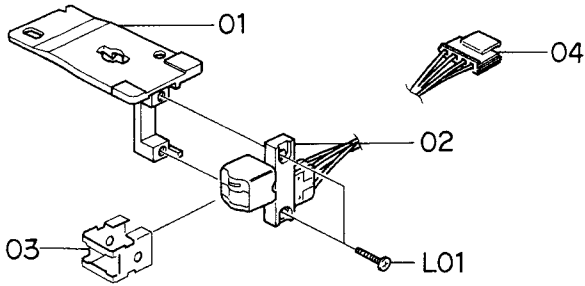

Fig. 8.22

8.23. R-8L Record Head Ass'y (G02)

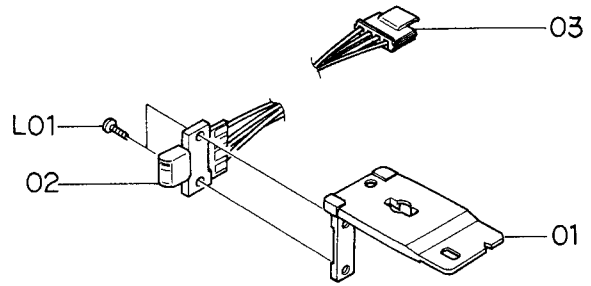

Fig. 8.23

Schematic Ref. No.	Part No.	Description	Q'ty	Schematic Ref. No.	Part No.	Description	Q'ty
G01	CA08127A	P-8L Playback Head Ass'y	1	G02	CA08128A	R-8L Record Head Ass'y	1
01	0C08160F	Head Plate	1	01	0C08159G	Head Plate	1
02	GA02034A	P-8L Playback Head	1	02	GA01050A	R-8L Record Head	1
03	0C08169D	Pad Lifter 54	1	03	0B08619C	4P-H Connector B	1
04	0B08618C	4P-H Connector A	1	L01	0E00887A	Screw M1.7x4 Philips Pan Head	2
L01	0E00886A	Screw M1.7x6.5 Philips Pan Head	2				

9. OVERALL TIMING CHART

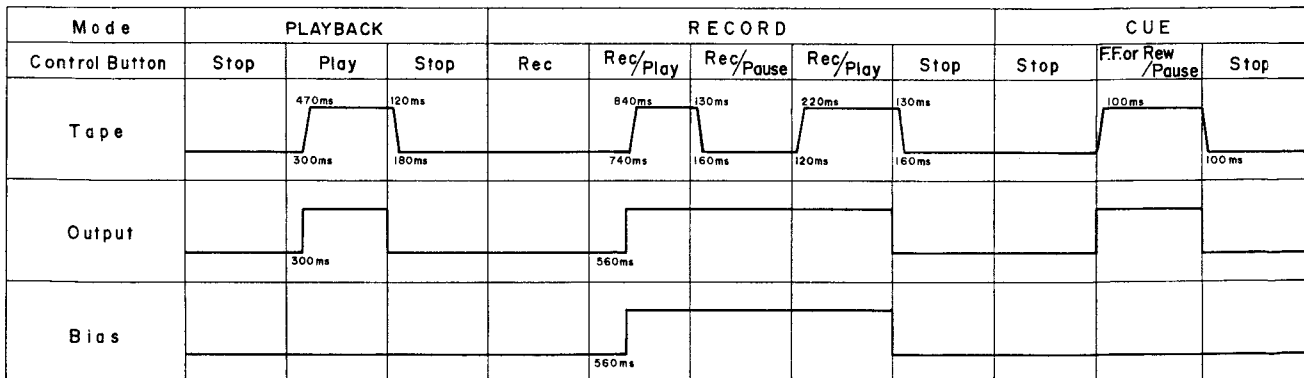

Fig. 9



10. EQ. AMP. FREQUENCY RESPONSE

10.1. Playback Frequency Response

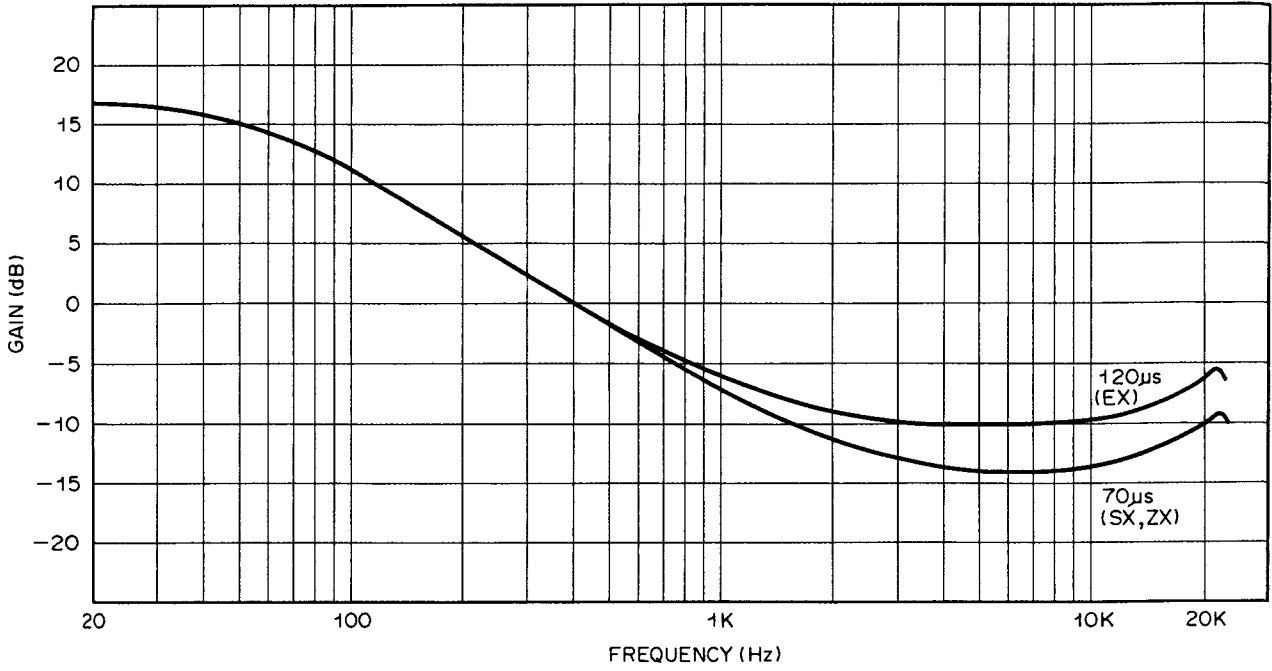

Fig. 10.1

10.2. Record Current Frequency Response

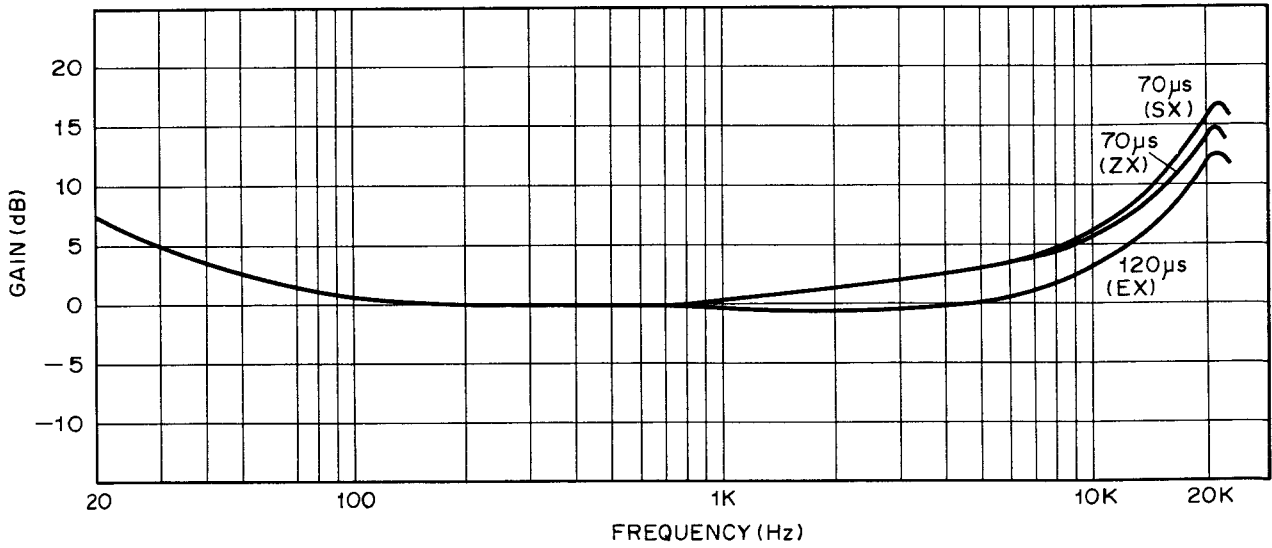

Fig. 10.2

11. WIRING DIAGRAM

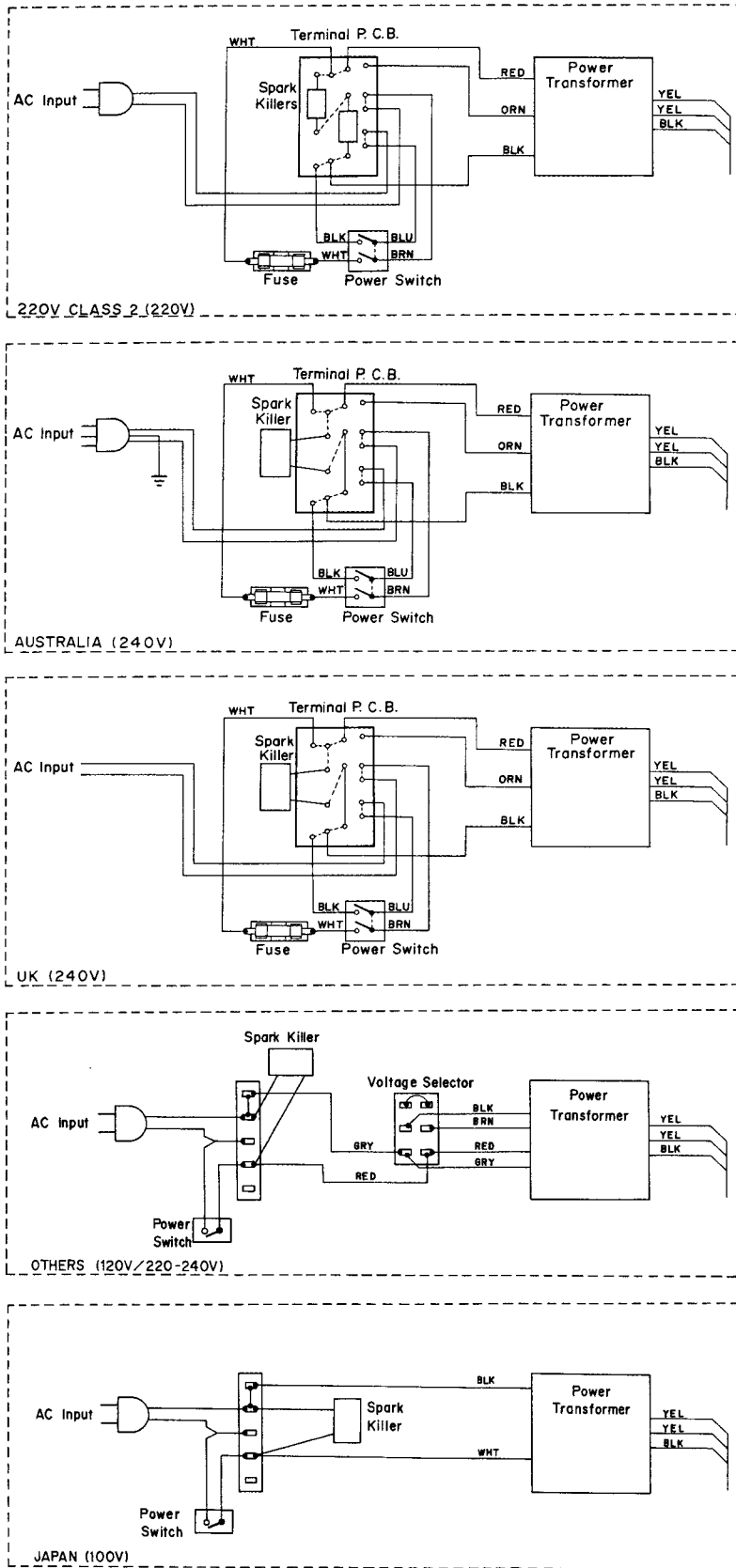
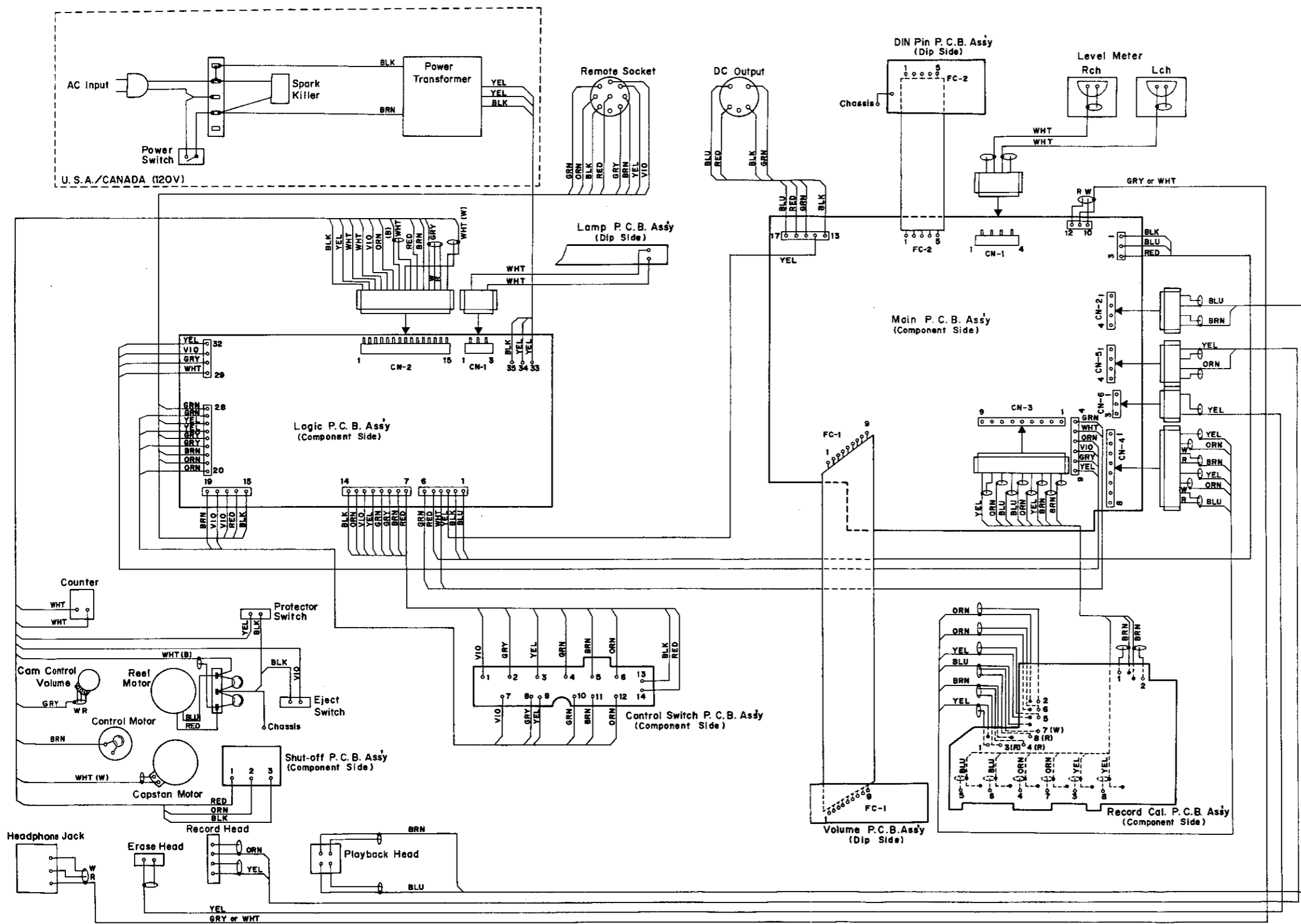

Fig. 11.1



Note: Table of wire colors

BLK - Black
 BLU - Blue
 ORN - Orange

GRY - Gray
 GRN - Green
 RED - Red

BRN - Brown
 YEL - Yellow
 WHT - White

Fig. 11.2

12. BLOCK DIAGRAMS

12.1. Amplifier

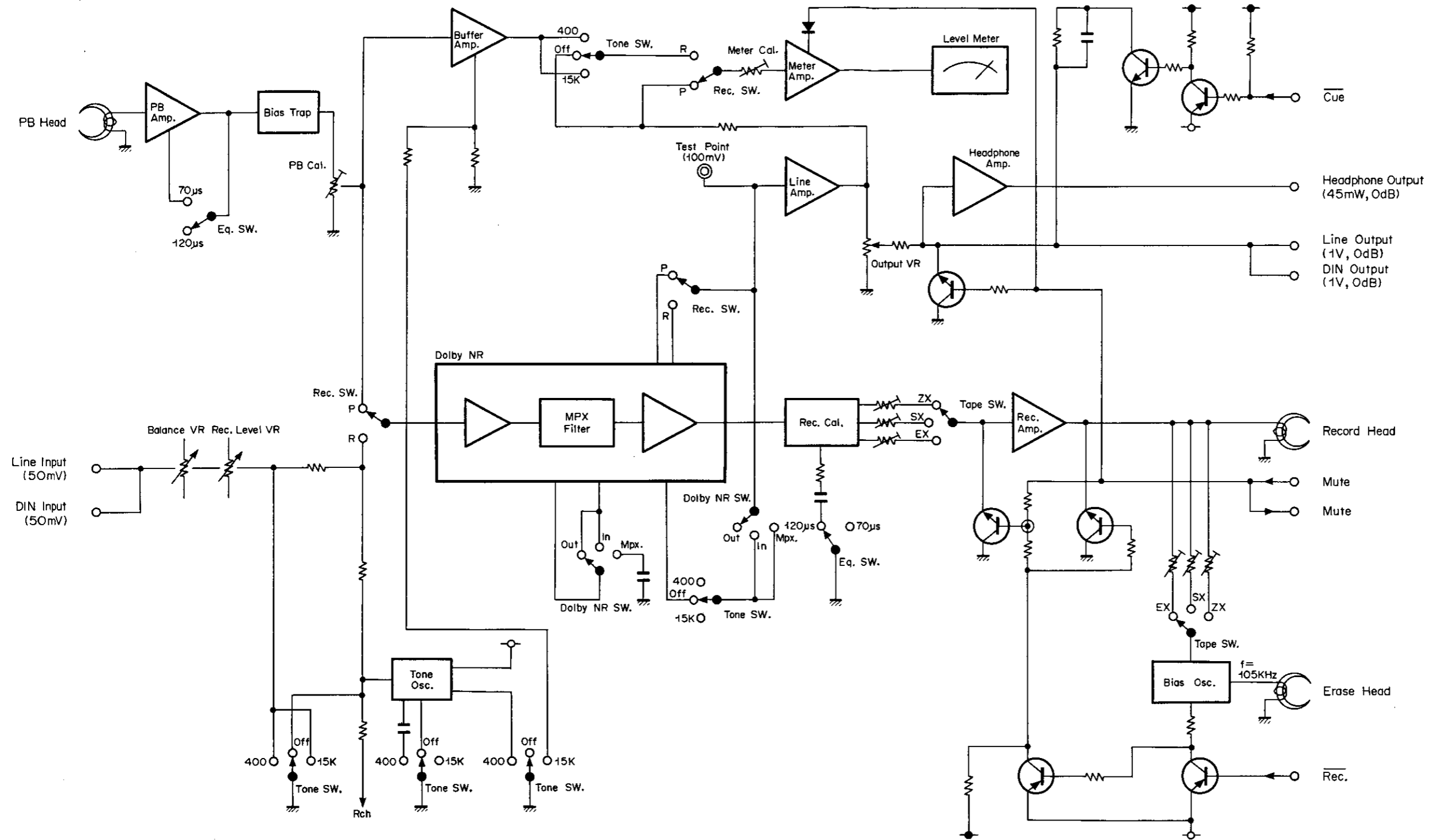

Fig. 12.1.1 Serial No.: A30206060 -

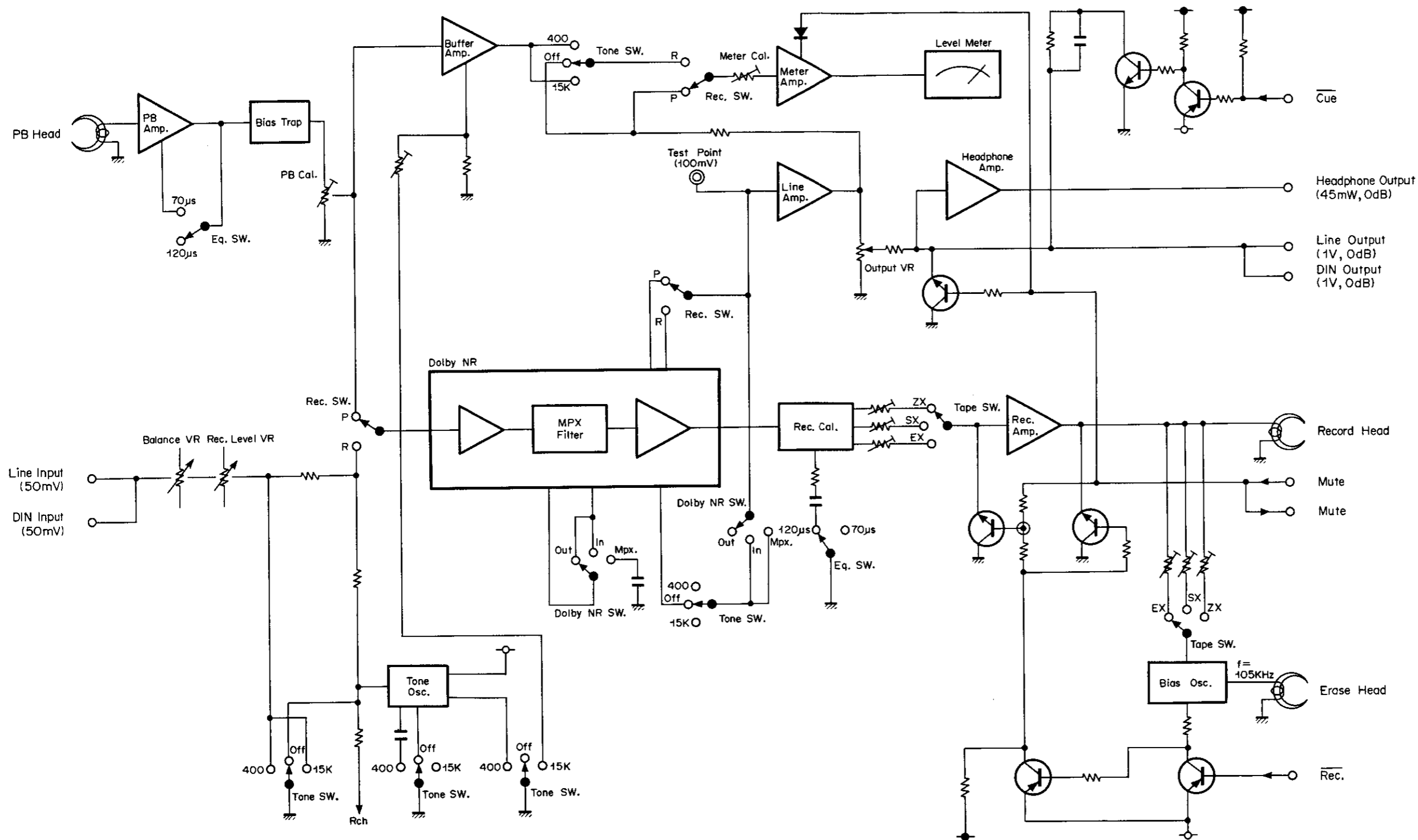

Fig. 12.1.2 Serial Nos.: A30201001 – A30206059

12.2. Mechanism Control

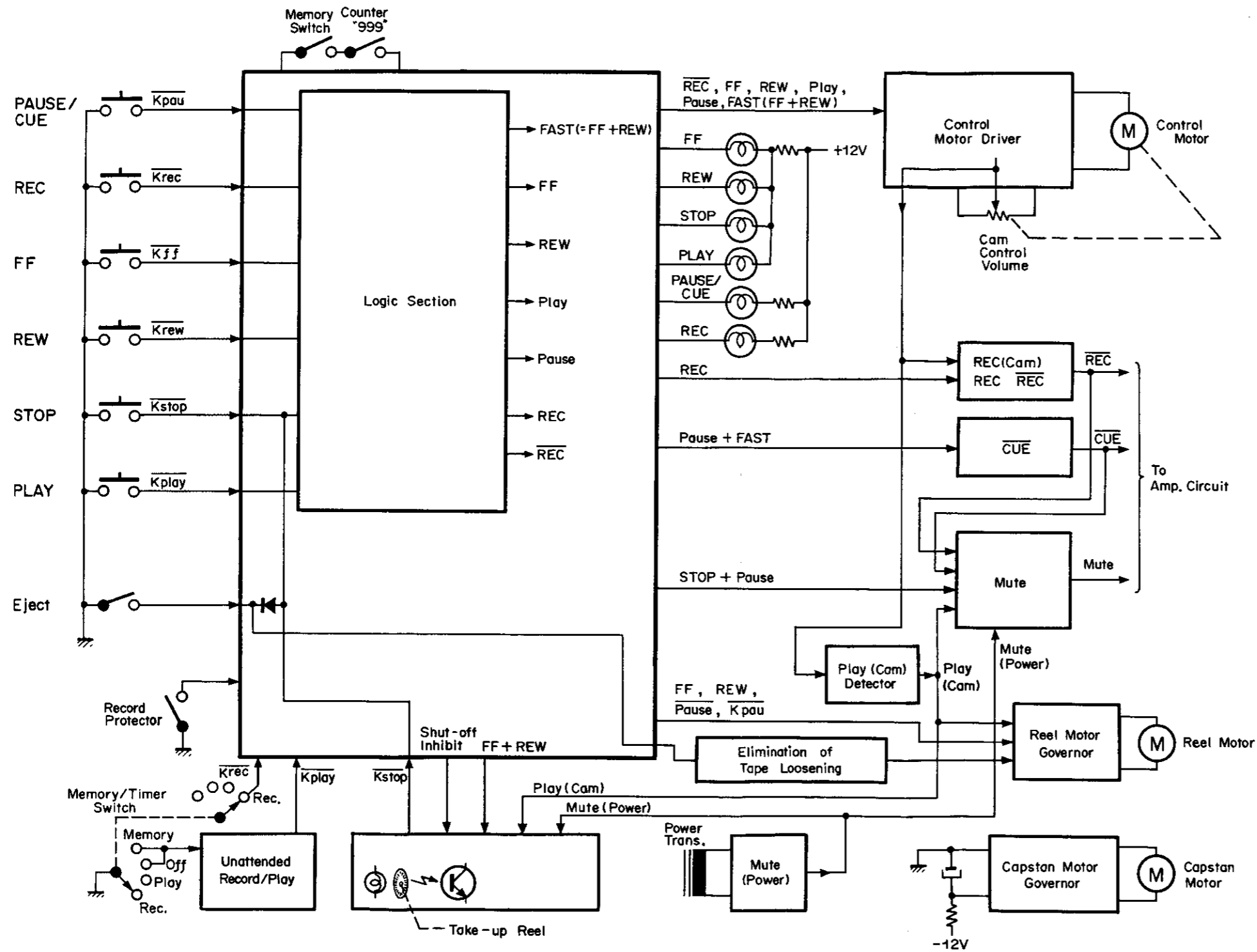

Fig. 12.2

13. SCHEMATIC DIAGRAMS

Note: Refer to diagrams of ICs on page 91.

13.1. Amplifier

Notes: 1. Diode is 1SS53, 1S953, or 1S1555 unless otherwise specified.
2. Resistor and capacitor marked with * show typical value.

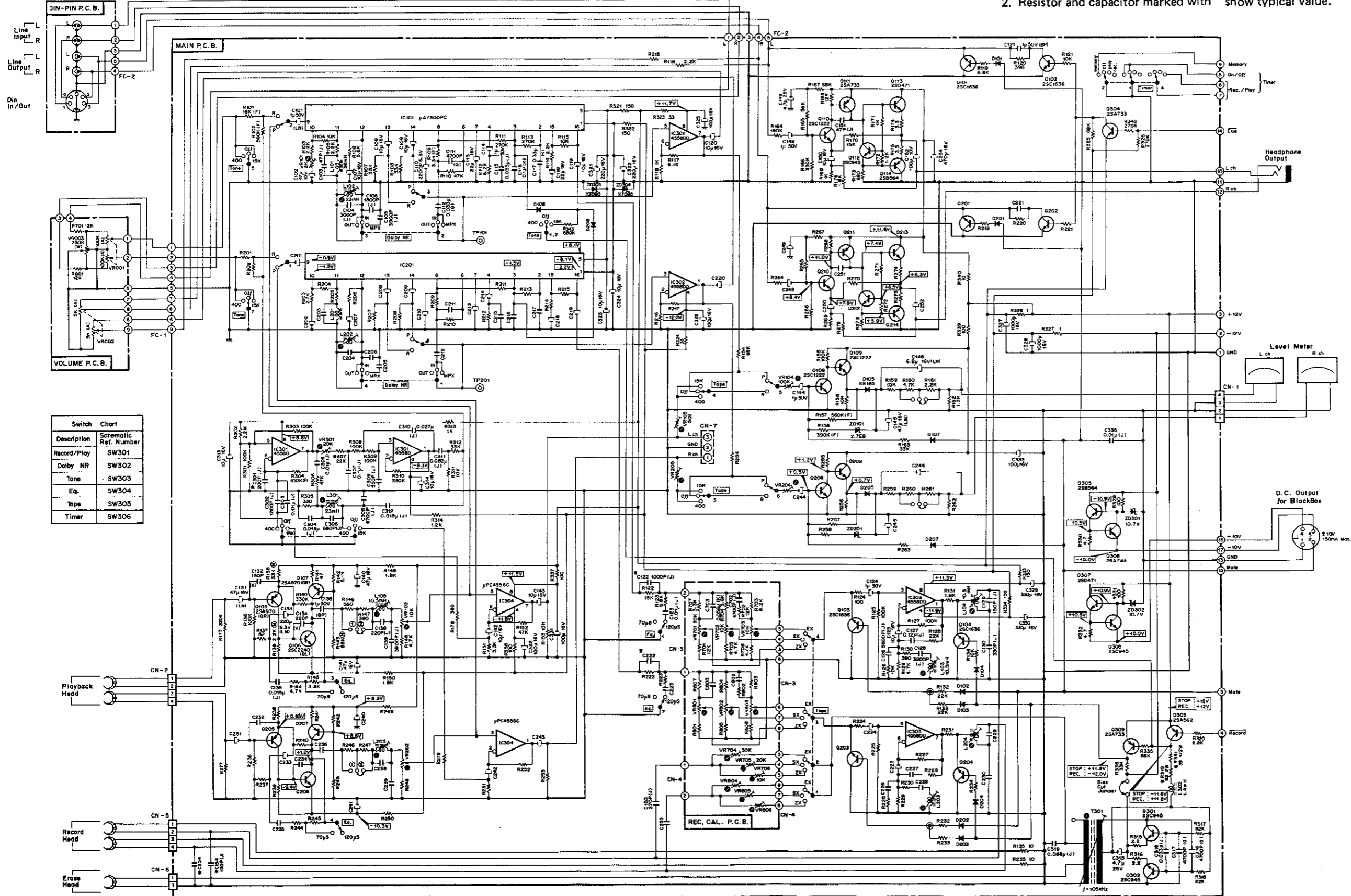
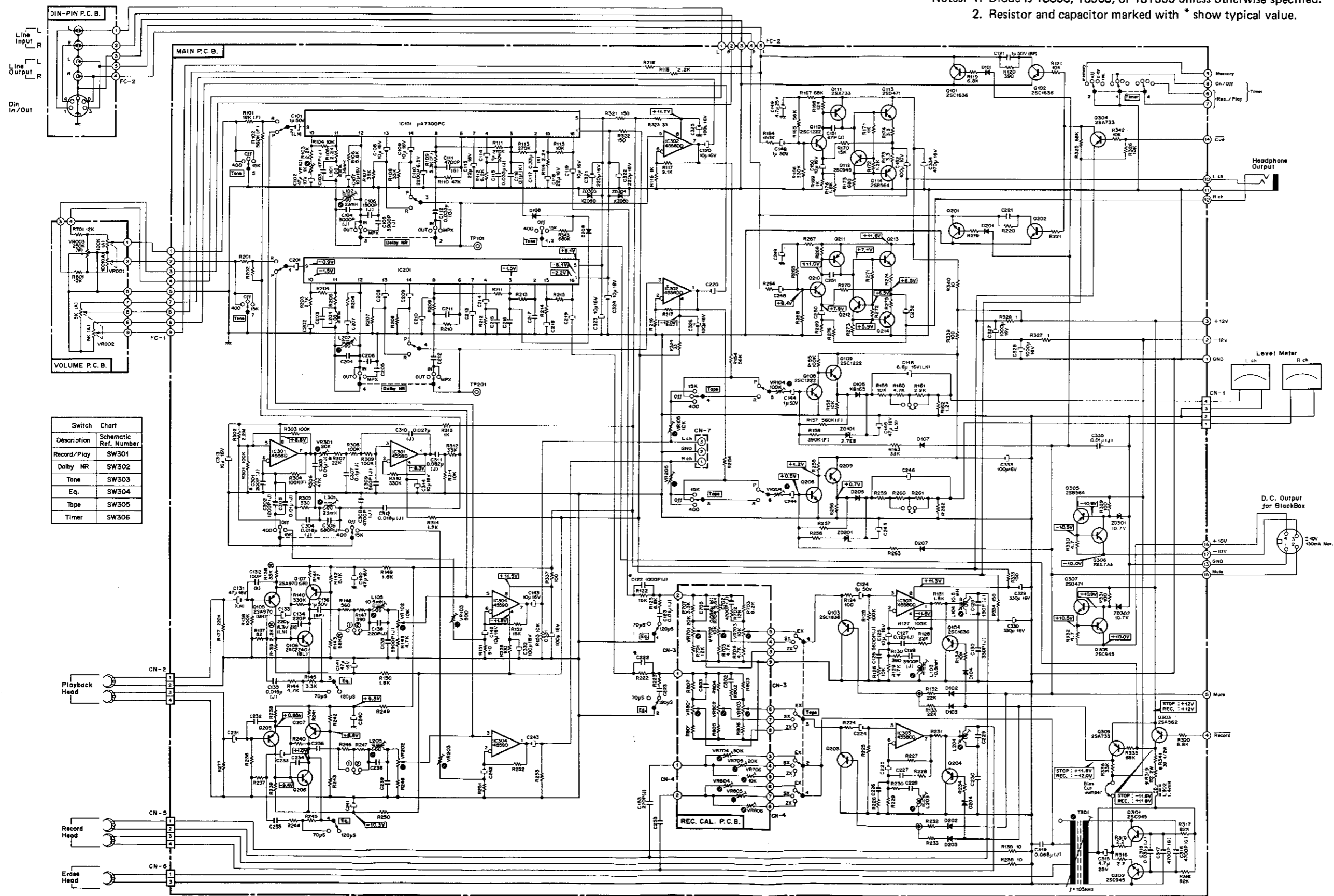

Fig. 13.1.1 Serial No.: A30206060 -



Notes: 1. Diode is 1SS53, 1S953, or 1S1555 unless otherwise specified.
 2. Resistor and capacitor marked with * show typical value.

Switch Chart	
Description	Schematic Ref. Number
Record/Play	SW301
Dolby NR	SW302
Tone	SW303
Eq.	SW304
Type	SW305
Timer	SW306

Fig. 13.1.2 Serial Nos.: A30201001 - A30206059

13.2. Mechanism Control

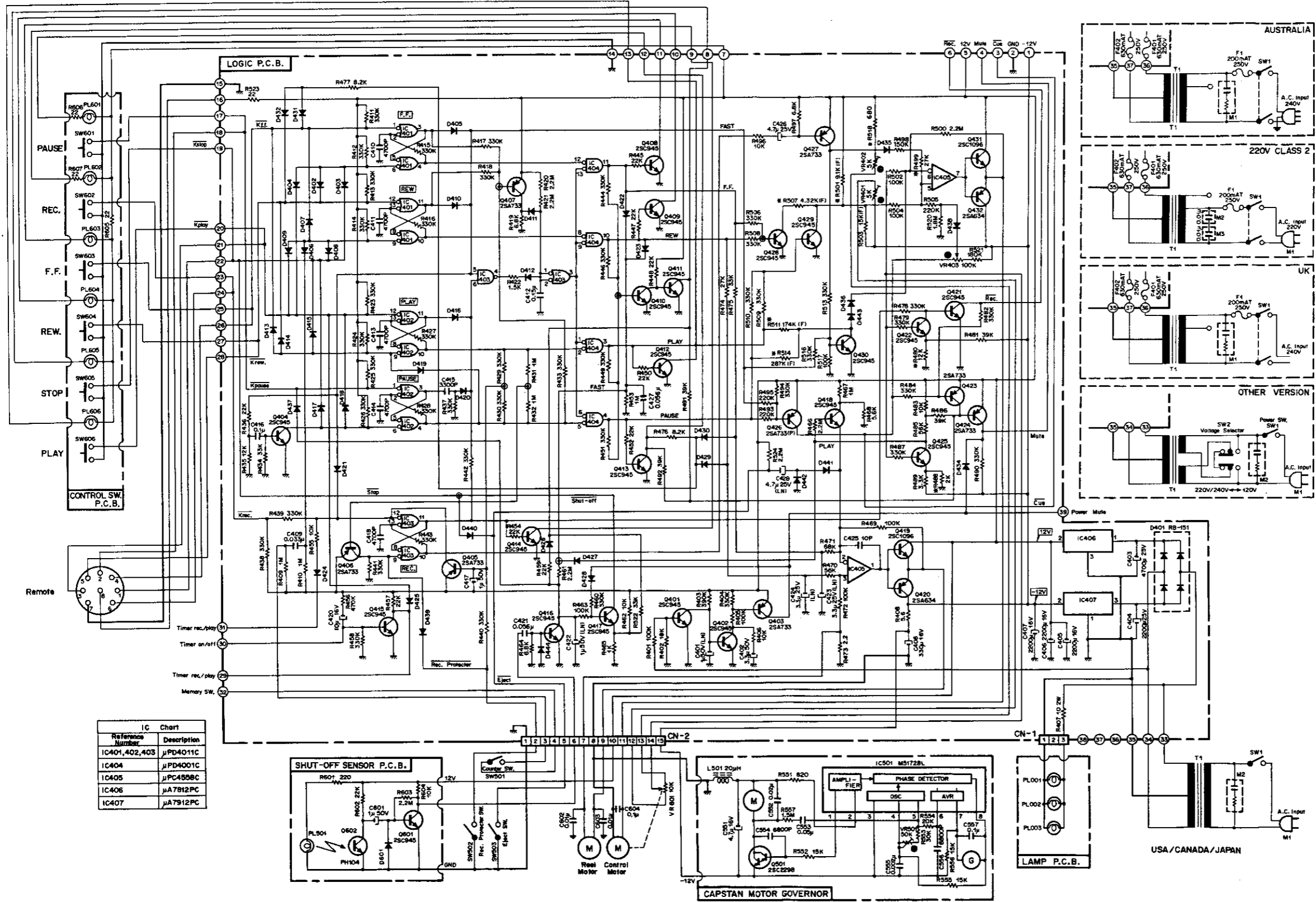

IC Chart	
Reference Number	Description
IC401,402,403	µPD4011C
IC404	µPC4001C
IC405	µPC4558C
IC406	µA7912PC
IC407	µA7912PC

Fig. 13.2.1
Serial No.: A30206790 -

Notes: 1. Diode is 1SS53, 1S953, or 1S1555 unless otherwise specified.
2. Resistor marked with * shows typical value.

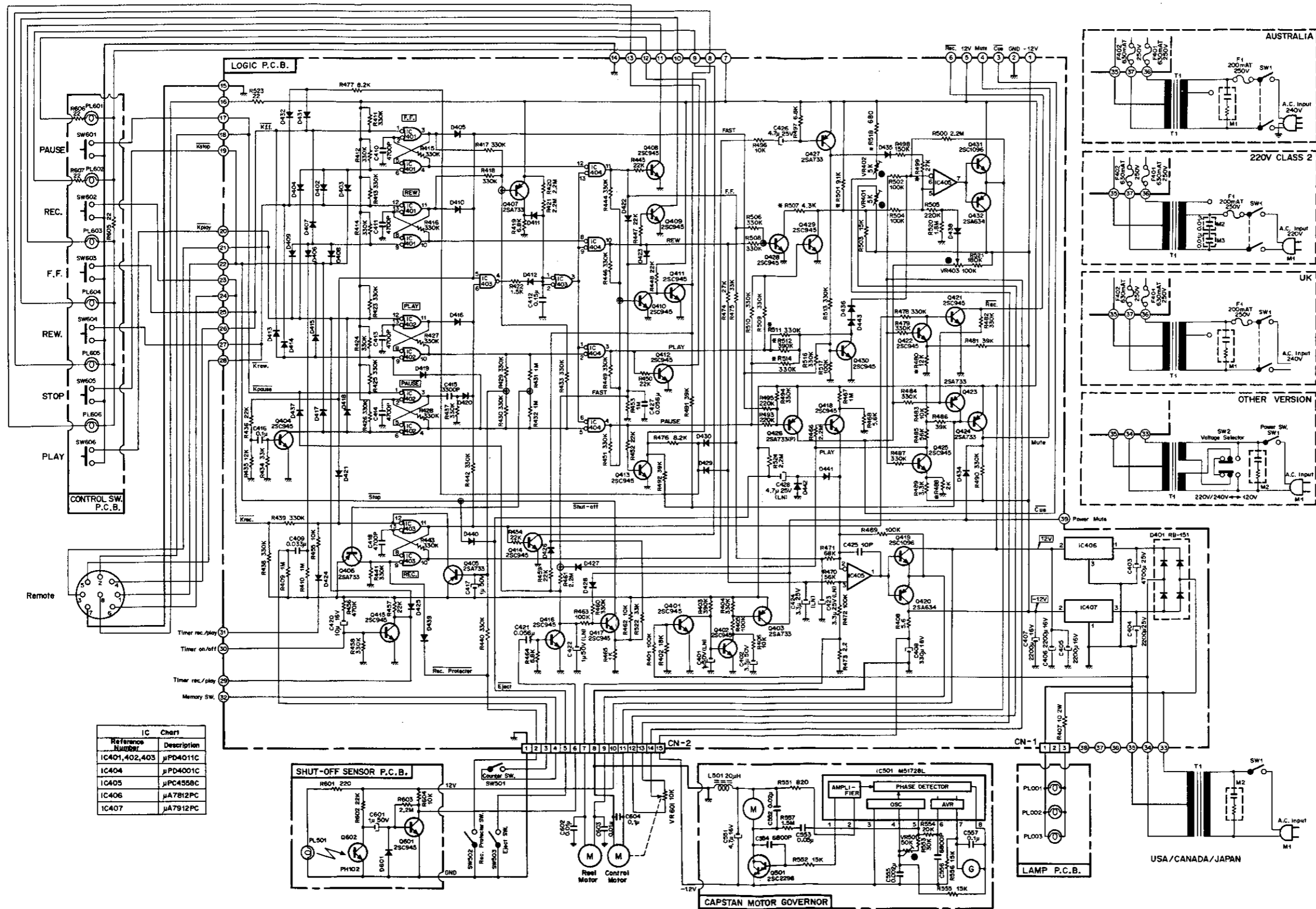

IC Chart	
Reference Number	Description
IC401,402,403	μPD4011C
IC404	μPD4001C
IC405	μPC4558C
IC406	μA7812PC
IC407	μA7912PC

Fig. 13.2.2
Serial Nos.: A30205002 – A30206789

Notes: 1. Diode is 1SS53, 1S953, or 1S1555 unless otherwise specified.
2. Resistor marked with * shows typical value.

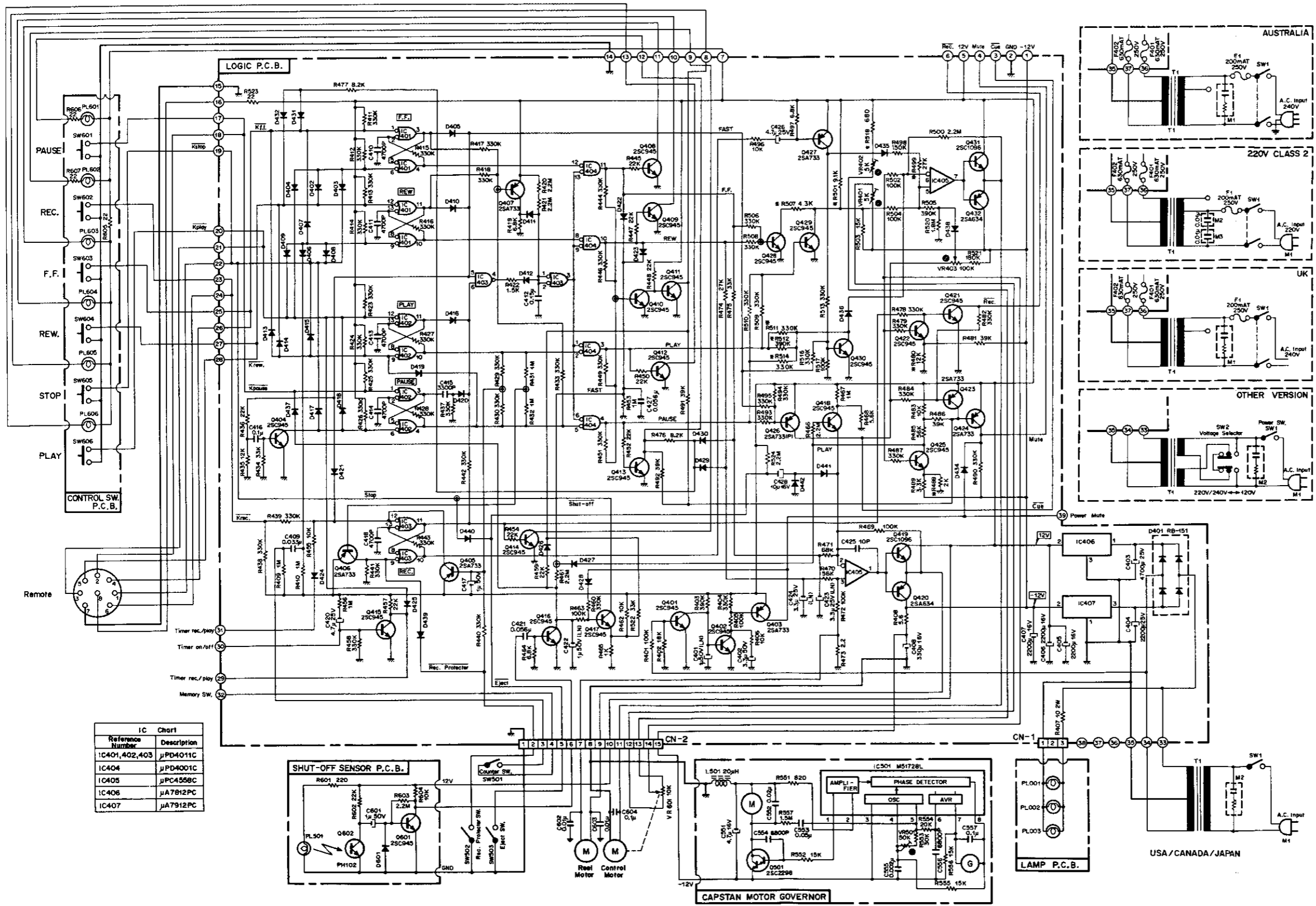

Reference Number	Description
IC401,402,403	μPD4011C
IC404	μPD4001C
IC405	μPC4558C
IC406	μA7812PC
IC407	μA7912PC

Fig. 13.2.3
Serial Nos.: A30201001 - A30205001

Notes: 1. Diode is 1SS53, 1S953, or 1S1555 unless otherwise specified.
2. Resistor marked with * shows typical value.

14. REMOTE CONTROL UNIT RM-580 (OPTIONAL)

Refer to item 2.4, principle of operation of RM-580.

14.1. Mounting Diagrams

Note: Mounting diagram shows a dip side view of the printed circuit board.

14.1.1. Receiver

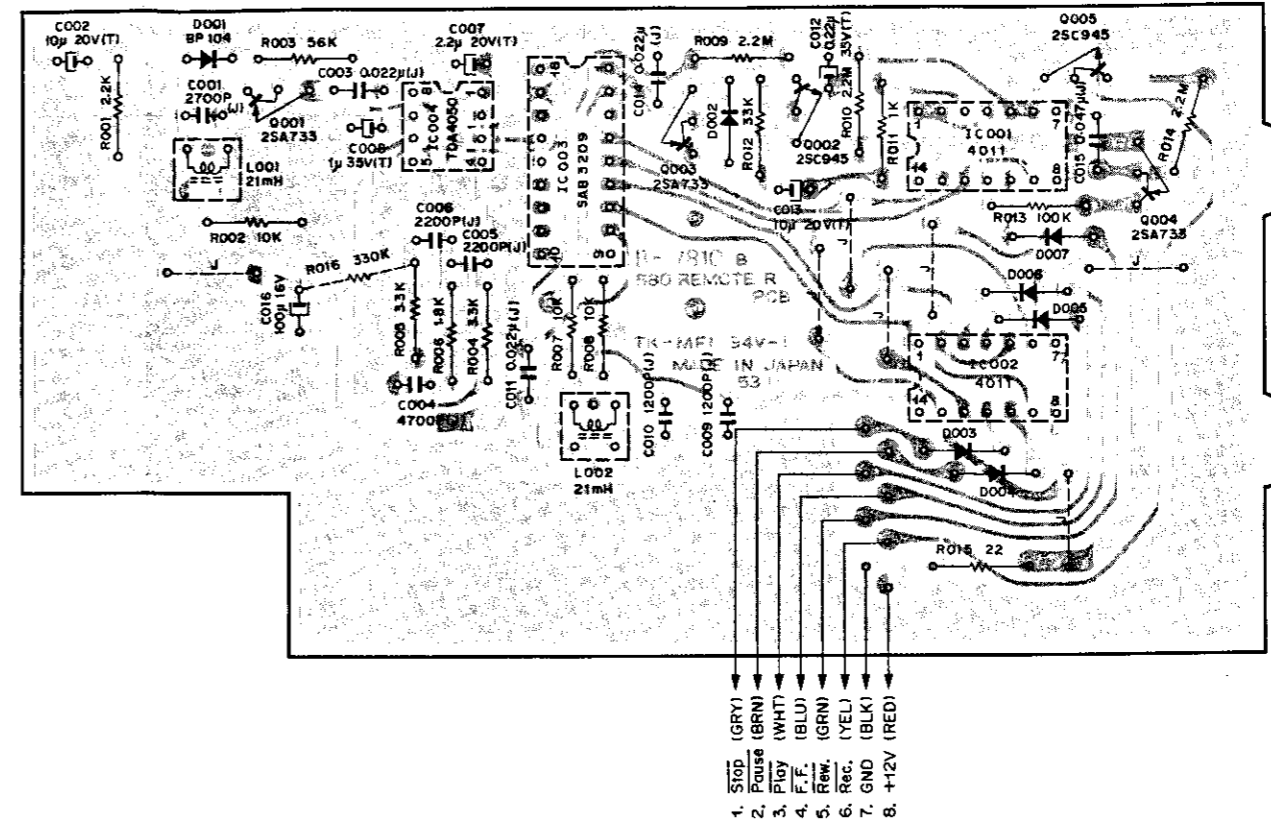

Fig. 14.1.1

Schematic Ref. No.	Part No.	Description	Schematic Ref. No.	Part No.	Description
	BA04002A	Remote Receiver P.C.B. Ass'y	R011	0B01857A	Carbon Resistor 1K ERD-25T J
			R012	0B05509A	Carbon Resistor 33K ERD-25T J
			R013	0B01889A	Carbon Resistor 100K ERD-25T J
			R015	0B05579A	Carbon Resistor 22 ERD-25T J
			R016	0B05627A	Carbon Resistor 330K ERD-25T J
IC001,002	0B06178A	IC μ PD4011C	C001	0B09231A	SP Capacitor 2700P 50V J
IC003	0B06162A	IC SAB3209	C002,013	0B05581A	Tantalum Capacitor 10 μ 20V
IC004	0B06163A	IC TDA4050	C003,011	0B09291A	Ceramic Capacitor 0.022 μ 50V J
Q001,003	0B06013A	Transistor 2SA733	014		
Q002,005	0B06100A	Transistor 2SC945	C004	0B05652A	Mylar Capacitor 4700P 50V J
D001	0B06165A	Photo Diode BP104	C005,006	0B01802A	Mylar Capacitor 2200P 50V J
D002,003	0B01909A	Silicon Diode 1S1555	C007	0B05598A	Tantalum Capacitor 2.2 μ 20V
004,005			C008	0B05638A	Tantalum Capacitor 1 μ 35V
006,007			C009,010	0B05790A	SP Capacitor 1200P 50V J
L001,002	0B06588A	Coil 21mH	C012	0B05772A	Tantalum Capacitor 0.22 μ 35V
R001	0B05622A	Carbon Resistor 2.2K ERD-25T J	C015	0B05796A	Mylar Capacitor 0.047 μ 50V J
R002,007	0B01888A	Carbon Resistor 10K ERD-25T J	C016	0B01400A	Electrolytic Capacitor 100 μ 16V
R003	0B05508A	Carbon Resistor 56K ERD-25T J		0B08610A	Shield Plate N604 (1 pce.)
R004,005	0B01681A	Carbon Resistor 3.3K ERD-25T J		0B03924A	Gate Pin (2 pcs.)
R006	0B05614A	Carbon Resistor 1.8K ERD-25T J			
R009,010	0B05671A	Carbon Resistor 2.2M ERD-25T J			
014					

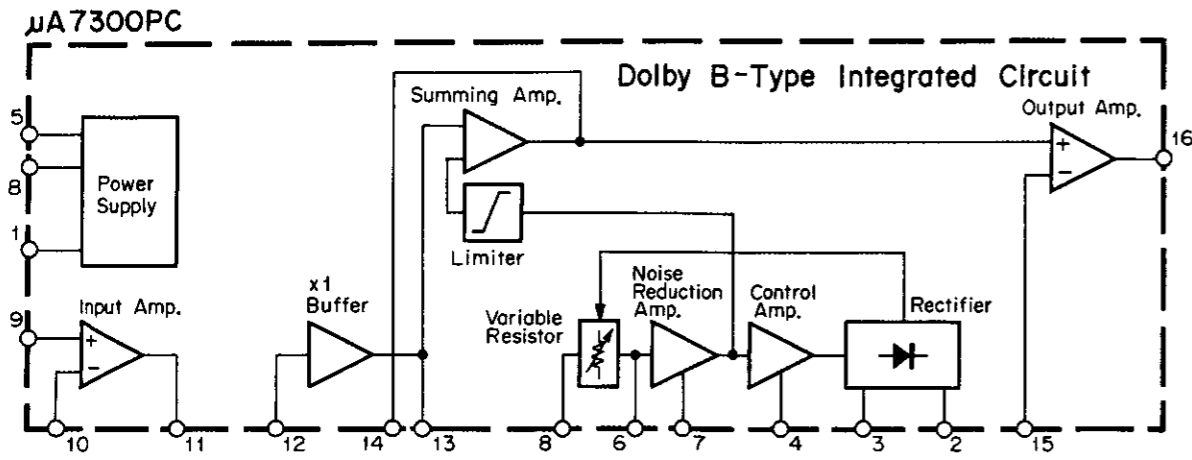

Fig. 13.3 Dolby NR IC μ A7300PC

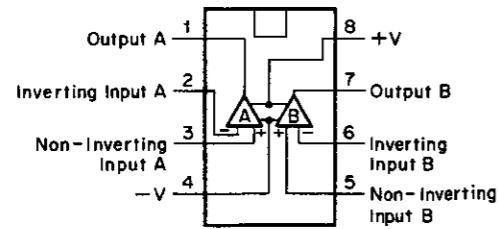

Fig. 13.4 Operational Amp. IC 4558

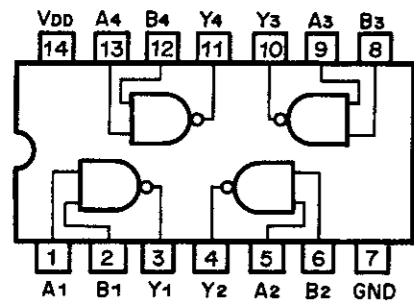

Fig. 13.5 C-MOS IC μ PD4011C

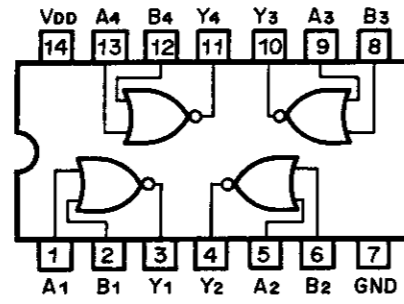

Fig. 13.6 C-MOS IC μ PD4001C

14.1.2. Transmitter

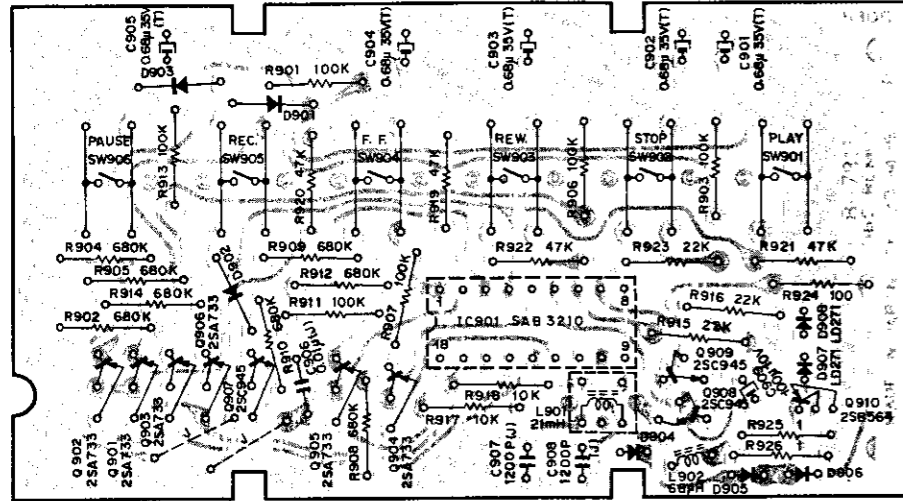

Fig. 14.1.2

Schematic Ref. No.	Part No.	Description
	BA04004A	Remote Transmitter P.C.B. Ass'y
	OB07811A	Remote Transmitter P.C.B.
IC901	OB06161A	IC SAB3210
C901,902 903,904 905,906	OB06013A	Transistor 2SA733
Q907,908 909	OB06100A	Transistor 2SC945
Q910	OB06069A	Transistor 2SB564
D901,902 903,904 905,906	OB01909A	Diode 1S1555
D907,908	OB06164A	LED LD271
L901	OB06588A	Coil 21mH
L902	OB06561A	Inductor 68μH
R901,903 906,907 911,913	OB01889A	Carbon Resistor 100K ERD-25T J
R902,904 905,908 909,910 912,914	OB05868A	Carbon Resistor 680K ERD-25T J
R915,916 923	OB05615A	Carbon Resistor 22K ERD-25T J
R917,918	OB01888A	Carbon Resistor 10K ERD-25T J
R919,920	OB05641A	Carbon Resistor 47K ERD-25T J
921,922		
R924	OB01679A	Carbon Resistor 100 ERD-25T J
R925,926	OB05695A	Carbon Resistor 1 ERD-25T J
C901,902 903,904 905	OB05773A	Tantalum Capacitor 0.68μ 35V
C906	OB09290A	Ceramic Capacitor 0.01μ 50V J
C907,908	OB05790A	SP Capacitor 1200P 50V J
C909	OB05885A	Electrolytic Capacitor 100μ 10V
SW901,902 903,904 905,906	OB07219A	Switch AKC8S

14.2. Schematic Diagrams

14.2.1. Receiver

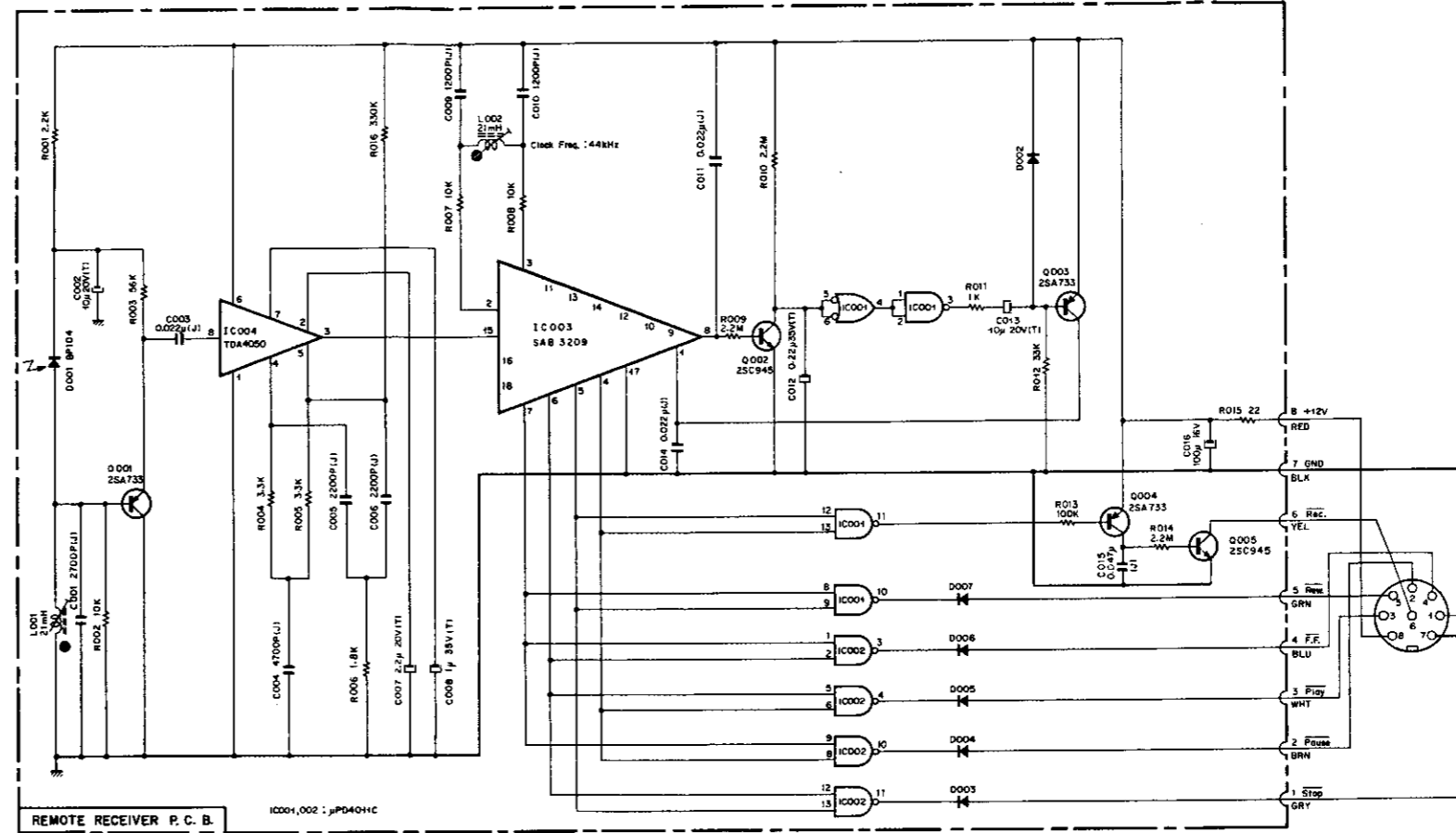

Fig. 14.2.1

14.2.2. Transmitter

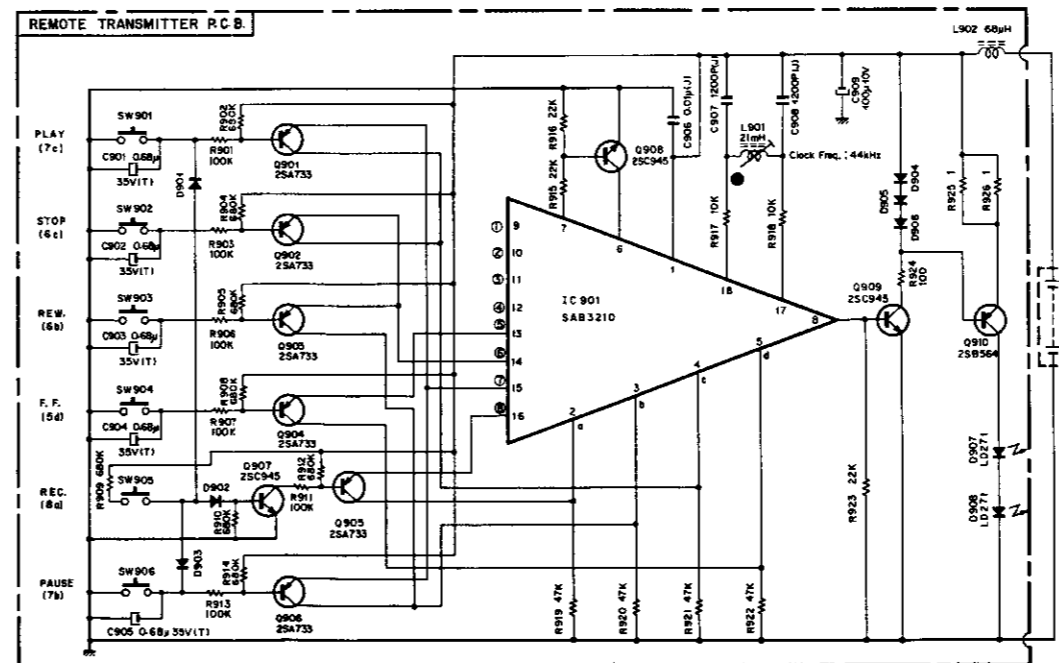

Fig. 14.2.2

14.3. Adjustments

14.3.1. Transmitter

- (1) Disassemble the Bottom Case, then remove the Remote Transmitter P.C.B. Ass'y.
- (2) Supply +9 V DC from an external Regulated Power Supply to the DC line of the Remote Transmitter P.C.B. Ass'y.
- (3) Connect a Frequency Counter across the IC901-18 pin and ground.
- (4) Push the Play Microswitch (SW901) to turn ON the power.
- (5) Adjust Coil L901 to obtain $44 \text{ kHz} \pm 50 \text{ Hz}$ on the Frequency Counter.
- (6) Release the Play Microswitch (SW901), then remove the Regulated Power Supply and the Frequency Counter.
- (7) Assemble the Remote Transmitter Ass'y.

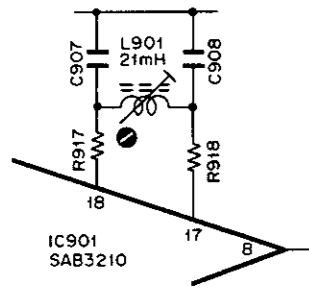

Fig. 14.3.1

14.3.2. Receiver

- (1) Disassemble the Receiver Case, then remove the Remote Receiver P.C.B. Ass'y.
- (2) Supply +12 V DC to the Remote Receiver P.C.B. Ass'y from an external Regulated Power Supply by connecting +12 V DC of the Regulated Power Supply to pin No.8 (RED) of the Remote Cord and ground to pin No. 7 (BLACK), or from the N-581 by plugging Remote Cord into Remote Control Socket of the N-581.
- (3) Connect a Frequency Counter across the IC003 (SAB3209)-2 pin and ground.
- (4) Adjust Coil L002 to obtain $44 \text{ kHz} \pm 50 \text{ Hz}$ on the Frequency Counter.

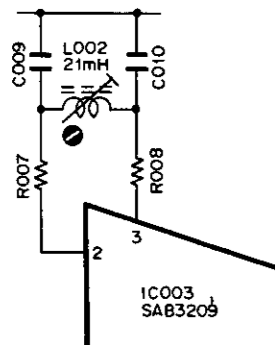

Fig. 14.3.2

- (5) Insert a 1-M Ω resistor in series to the Oscillator output, then connect it across the base of Q001 and ground.
- (6) Set the output of the Oscillator to the order of a few voltage, then calibrate the oscillator frequency to $22 \text{ kHz} \pm 25 \text{ Hz}$ monitoring the frequency by the Frequency Counter.
- (7) Connect an AC Voltmeter across the emitter of Q001 and ground.
- (8) Adjust Coil L001 to obtain maximum reading on the AC Voltmeter.
- (9) Remove the Oscillator, AC Voltmeter and Regulated Power Supply, then assemble the Remote Receiver Ass'y.

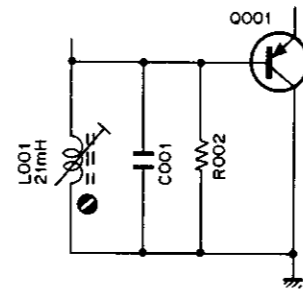

Fig. 14.3.3

14.3.3. Performance Check of Transmitter and Receiver

- (1) Connect the Receiver to the Remote Control Socket of the N-581.
- (2) Press each control switch of the Transmitter and check to insure whether every function operates accurately.

Note: Possible operating zone of the Transmitter is shown in Fig. 14.3.4.

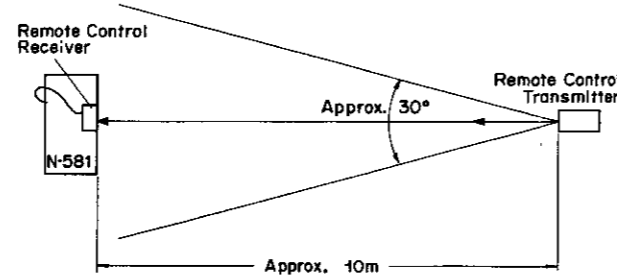

Fig. 14.3.4

14.4. Mechanism Ass'y and Parts List

14.4.1. Receiver

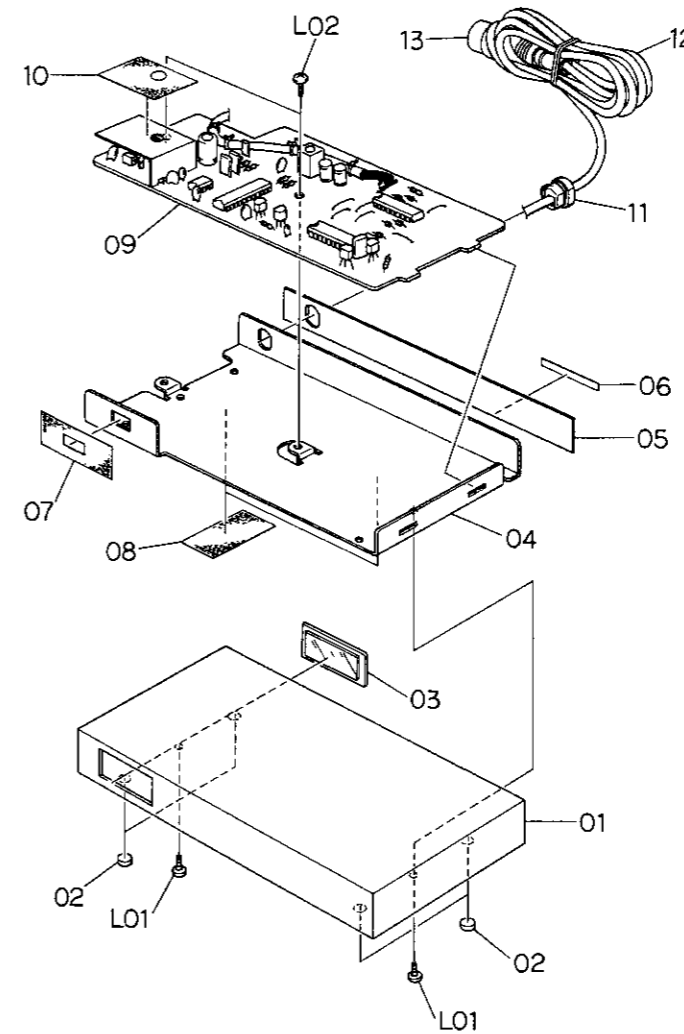

Fig. 14.4.1

Schematic Ref. No.	Part No.	Description	Q'ty
		Remote Receiver Ass'y	
01	0H03702B	Receiver Case	1
02	0A03285B	Leg RM 580	4
03	0H03649A	Acrylic Cover	1
04	0J03995B	Receiver Chassis	1
05	0M03975D	Rear Plate	1
06	0M03982A	Serial No. Seal (Receiver)	1
07	0J03996A	Chassis Mask	1
08	0J04008A	Chassis Himelon	2
09	BA04002A	Remote Receiver P.C.B. Ass'y	1
10	0J04007A	P.C.B. Himelon	1
11	0B08587A	Cord Bushing	1
12	0B05222B	8P Cord	1
13	0B08585A	8P DIN Plug	1
L01	0E00860A	BT Screw M3x6 Philips Binding Head (Bronze)	2
L02	0E00857A	BT Screw M3x6 Philips Binding Head	2

14.4.2. Transmitter

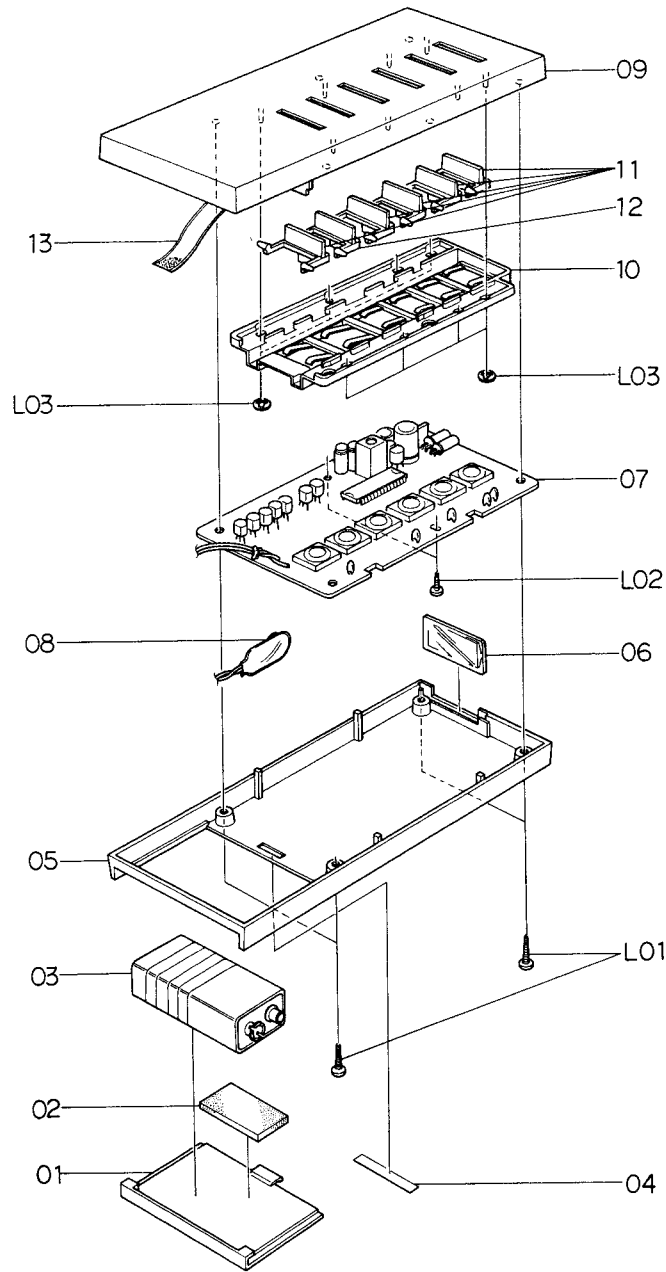

Fig. 14.4.2

Schematic Ref. No.	Part No.	Description	Q'ty	Schematic Ref. No.	Part No.	Description	Q'ty
		Remote Transmitter Ass'y		10	0J03994B	Spring Plate	1
01	0H03705A	Battery Cover	1	11	0H03659A	Control Button B	5
02	0J03905A	Battery Cushion	1	12	0H03658A	Control Button A	1
03	0B08529A	Battery 9V	1	13	0J03906A	Battery Ribbon	1
04	0M03976A	Serial No. Seal (Transmitter)	1	L01	0E00825A	BT Screw M2.6x8 Philips Binding Head	4
05	0H03704A	Bottom Case	1	L02	0E00824A	BT Screw M2.6x6 Philips Pan Head	2
06	0H03657A	Smoked Filter	1	L03	0E00874A	Stopper Ring CS 2mm	3
07	BA04004A	Remote Transmitter P.C.B. Ass'y	1				
08	0B05223B	Battery Snap B 110mm	1				
09	0H03701C	Top Case	1				



15. SPECIFICATIONS

Power Source	100, 120, 120/220-240, 220 or 240 V; 50/60 Hz
Power Consumption	27 W Max.
Tape Speed	1-7/8 ips. (4.8 cm/sec.) \pm 0.5%
Wow and Flutter	Less than 0.1% WTD Peak, 0.05% WTD rms
Frequency Response	20-20,000 Hz \pm 3 dB (-20 dB Rec. Level)
Signal to Noise Ratio	Better than 60 dB at 400 Hz, 0 dB, WTD rms
(Dolby NR In, 70 μ s)	Better than 66 dB at 400 Hz, 3% THD, WTD rms
Total Harmonic Distortion	Less than 0.8% at 400 Hz, 0 dB (ZX Tape)
	Less than 1.0% at 400 Hz, 0 dB (SX, EXII Tapes)
Erasure	Better than 60 dB below saturation level at 1 kHz
Separation	Better than 37 dB at 1 kHz, 0 dB
Crosstalk	Better than 60 dB at 1 kHz, 0 dB
Bias Frequency	105 kHz
Input	50 mV, 50 k ohms
Output Level	1 V (400 Hz, 0 dB, Output Level at Max.) 2.2 k ohms
Headphone	45 mW
DC Output Jack	\pm 10V 125 mA Max.
Dimensions	500(W) x 130(H) x 350(D) m/m
	19-11/16(W) x 5-1/8(H) x 13-25/32(D) inches
Approximate Weight	8.3 kg, 18 lb, 5 oz

- Specifications and appearance design are subject to change for further improvement without notice.
- Dolby NR under license from Dolby Laboratories.
- The word "DOLBY" and the Double-D-Symbol are trademarks of Dolby Laboratories.