

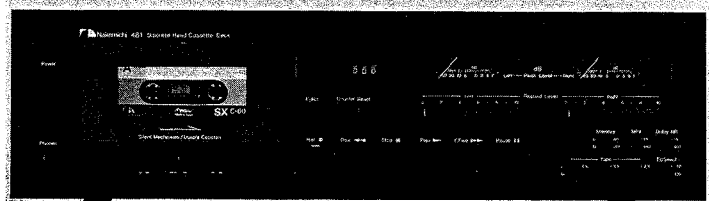

Service Manual

Nakamichi 481

Discrete Head Cassette Deck



CONTENTS

1. General	3
2. Principle of Operation	4
2. 1. Mechanisms	4
2.1.1. Headblock	4
2.1.2. Erase Head	5
2.1.3. Double Capstan Tape Drive	5
2.1.4. Mechanism Control Cam Operation	6
2. 2. Amp. Circuits	7
2.2.1. Playback Eq. Amp. Circuit	7
2.2.2. Record Eq. Amp. Circuit	9
2.2.3. Bias Osc. Circuit	9
2. 3. Mechanism Control Circuits	10
2.3.1. Outline	10
2.3.2. +12 V Power Source	11
2.3.3. Power-mute Signal	11
2.3.4. Auto Shut-off Circuit	11
2.3.5. Record Control Circuit	14
2.3.6. Mute Signal	14
2.3.7. Control Motor Drive Circuit	15
2.3.8. Reel Motor Governor	16
3. Removal Procedures	17
3. 1. Cassette Case Cover Ass'y	17
3. 2. Top Cover Ass'y	17
3. 3. Bottom Cover Ass'y	17
3. 4. Front Panel Ass'y	17
3. 5. Headphone Jack Ass'y	17
3. 6. Mechanism Ass'y	17
3. 7. Meter Ass'y	17
3. 8. Lamp P.C.B. R Ass'y and Lamp P.C.B. L Ass'y	17
3. 9. Main P.C.B. Ass'y	17
3. 10. Control Switch Holder Ass'y	17
3. 11. Switch P.C.B. Ass'y	17
3. 12. Volume P.C.B. Ass'y and Control Switch P.C.B. Ass'y	17
3. 13. Rear Panel Ass'y, Power Transformer and Power Switch	17
3. 14. Cassette Case Ass'y and Cover Plate Ass'y	19
3. 15. Tape Counter Ass'y	19
3. 16. Capstan Motor Ass'y and Flywheel Ass'y	20
3. 17. Sub Mechanism Chassis Ass'y	20
3. 18. Control Motor Ass'y and Reel Motor Ass'y	20
3. 19. Cam Control Volume	20
3. 20. Reel Hub Ass'y and Idler Ass'y	20
3. 21. Cam Drive Gear and Control Cam	20
3. 22. Head Mount Base Ass'y	20
3. 23. Pressure Roller Ass'y and Erase Head	20
3. 24. Playback Head Ass'y and Record Head Ass'y	20
4. Measurement Instruments	21
5. Mechanical Adjustments	21
5. 1. Mechanism Control Cam Adjustment	21
5. 2. Tape Speed Adjustment	22
5. 3. Record Head and Playback Head Tilt Adjustment	23
5. 4. Head Base Stroke Adjustment	24
5. 5. Tape Guides Adjustment and Erase Head Stroke Adjustment	25
5. 6. Erase Head Height and Tilt Adjustment	26
5. 7. Playback Head and Record Head Height Adjustment and Azimuth Alignment	27
5. 8. Record Head Stroke Adjustment	28
5. 9. Tape Travelling Adjustment	29

5. 10.	Record Switch Linkage Adjustment	29
5. 11.	Flywheel Holder Adjustment	30
5. 12.	Eject Wire Adjustment	30
5. 13.	Lubrication	30
6.	Parts Location for Electrical Adjustment	31
7.	Electrical Adjustments and Measurements	32
7. 1.	Adjustment and Measurement Instructions	32
7. 2.	Playback Frequency Response Adjustment	35
7. 3.	Check on Dolby NR Circuit	35
8.	Mounting Diagrams and Parts List	36
8. 1.	Volume P.C.B. Ass'y	36
8. 2.	Control Switch P.C.B. Ass'y	36
8. 3.	Switch P.C.B. Ass'y	36
8. 4.	Control P.C.B. Ass'y	36
8. 5.	Auto Shut-off P.C.B. Ass'y	36
8. 6.	Lamp P.C.B. L Ass'y	36
8. 7.	Lamp P.C.B. R Ass'y	36
8. 8.	Main P.C.B. Ass'y	37
9.	Mechanism Ass'y and Parts List	41
9. 1.	Synthesis	41
9. 2.	Front Panel Ass'y (A01)	41
9. 3.	Synthesis Mechanism Ass'y (A02)	41
9. 4.	Meter Escutcheon Ass'y (B01)	42
9. 5.	Control Switch Holder Ass'y (B02)	43
9. 6.	Headphone Jack Ass'y (B03)	43
9. 7.	Mechanism Ass'y 481 (B04)	44
9. 8.	Chassis Ass'y (B05)	45
9. 9.	Flywheel Holder Ass'y (C01)	45
9. 10.	Sub Mechanism Chassis Ass'y (C02)	46
9. 11.	Main Mechanism Chassis Ass'y (C03)	47
9. 12.	Rear Panel Ass'y (D01)	49
9. 13.	Reel Motor Ass'y (E01)	50
9. 14.	Control Motor Ass'y (E02)	50
9. 15.	Head Mount Base Ass'y (F01)	50
9. 16.	Supply Pressure Roller Ass'y (F02)	50
9. 17.	Take-up Pressure Roller Ass'y (F03)	50
9. 18.	Head Base Ass'y C (F04)	51
9. 19.	Cassette Case Holder L Ass'y (F05)	51
9. 20.	Cassette Case Holder R Ass'y (F06)	51
9. 21.	Auto Shut-off Ass'y (F07)	51
9. 22.	Pneumatic Damper Ass'y (F08)	51
9. 23.	P-8L Playback Head Ass'y (G01)	51
9. 24.	R-8L Record Head Ass'y (G02)	51
10.	Overall Timing Chart	53
11.	Eq. Amp. Frequency Response	54
11. 1.	Playback Frequency Response	54
11. 2.	Record Current Frequency Response	54
12.	Wiring Diagram	55
13.	Block Diagrams	57
13. 1.	Amplifier	57
13. 2.	Mechanism Control	58
14.	Schematic Diagrams	59
15.	Specifications	62

1. GENERAL

1.1. Control Functions

Nakamichi 481 control functions are shown below:

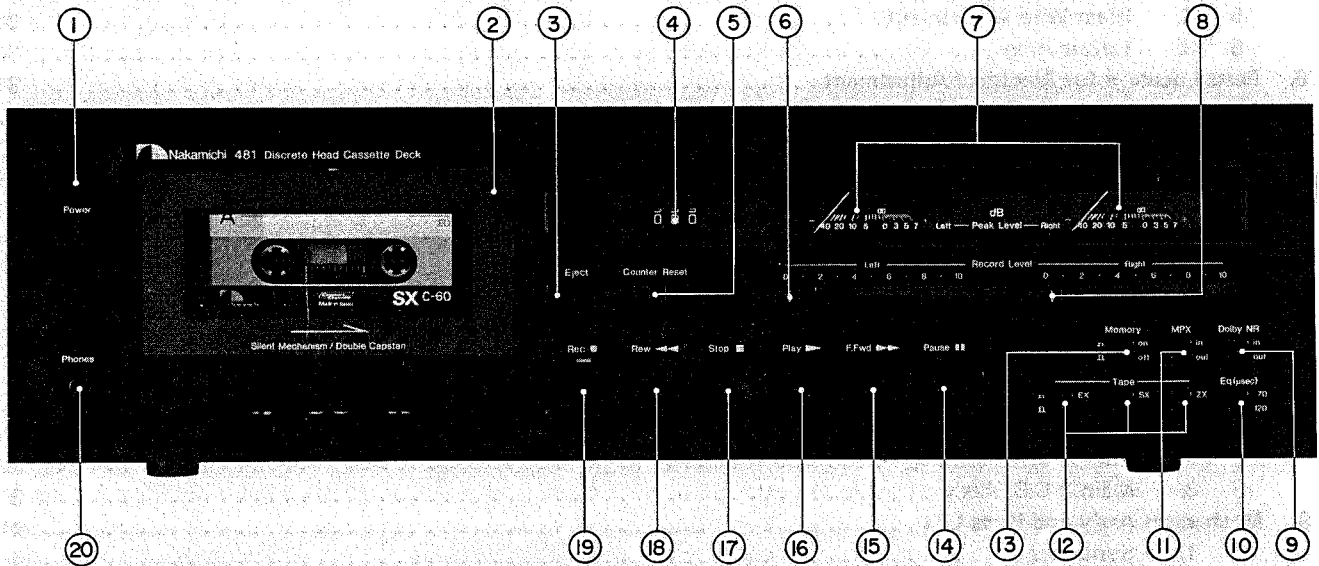

Fig. 1.1 Front View

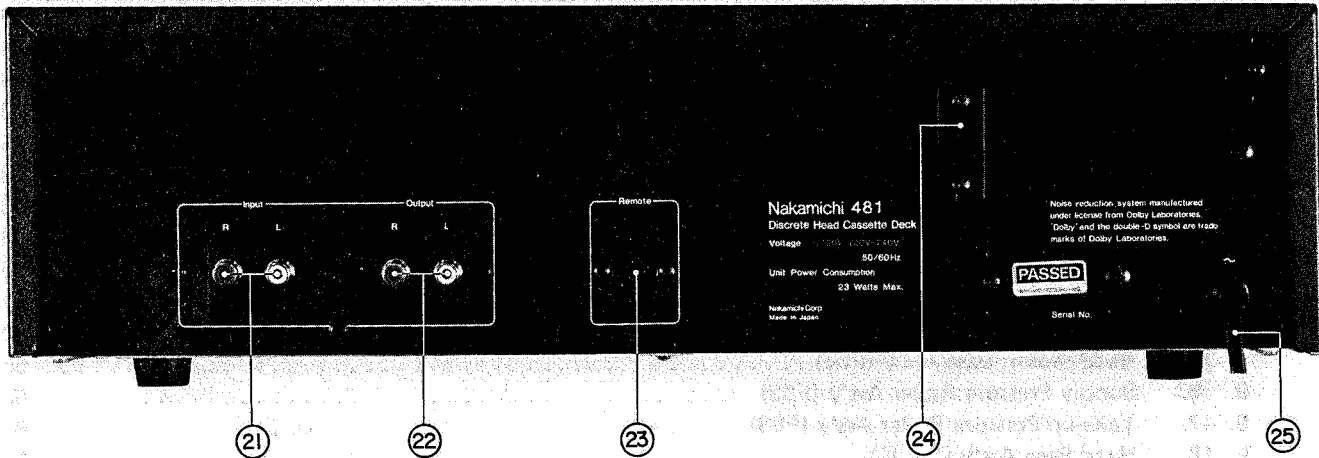

Fig. 1.2 Rear View

1. Power Switch
2. Cassette Lid
3. Eject Button
4. Tape Counter
5. Counter Reset Button
6. Input Level Control - Left Channel
7. Peak Level Meters
8. Input Level Control - Right Channel
9. Dolby NR Switch
10. Eq. Switch
11. MPX Filter Switch
12. Tape Selector Switches
13. Tape Memory Switch

14. Pause Button
15. Fast-Forward Button
16. Play Button
17. Stop Button
18. Rewind Button
19. Record Button
20. Headphone Jack
21. Input Jacks
22. Output Jacks
23. Remote Control Socket
24. Voltage Selector Switch
25. Power Cord

1.2. Voltage Selector

Voltage selector is installed on the rear panel for other versions of the Nakamichi 481. This voltage selector can select either 120 V or 220 - 240 V at customer's disposal.

2. PRINCIPLE OF OPERATION

2.1. Mechanisms

2.1.1. Headblock

Refer to Fig. 2.1.1 Headblock.

Nakamichi 481 Headblock provides more stabilized tape travel.

Accuracy of tape travel is one of the most essential factors for a device to optimize its performance. Inaccurate tape travel will therefore induce deterioration exemplified by the following:

- vibration will be given to tape travel, as a result of which flutter and modulation noise will become increased
- insufficient tape-to-head contact will result in level drops
- tape skew will become greater and frequency response will become decreased

Needless to say, constant tape travel must consist of smooth drive mechanism, as well as of the fact that tape, heads and tape guide are placed in the most appropriate positions.

N-481 Playback Head and Record Head, they are both made small in size so that the both heads are assembled in a space of the conventional Record/Playback Head. Erase Head is located at the place where the Record Head is located in the N-700II/1000II.

Both Playback Head and Record Head are assembled on the Head Mount Base. Take-up Tape Guide and Supply Tape Guide are fixed to the Take-up Pressure Roller Arm and Supply Pressure Roller Arm, respectively. Erase Head is placed on the Head Base. All these can be separately adjusted.

Record Head is placed slightly backward, approximately 0.15 mm away from the Playback Head. Record Head is placed approximately 3° inclined leftward. Shape of the Heads and its location have been carefully studied to bring about smoother contact of tape with the Heads. Pad Lifter is affixed to the Playback Head so as not to let Tape Pad touch the Head to give more stabilized tape travel, making it free from the influence of the Tape Pad within the Cassette Tape. Thus the trouble of changes in azimuth can now be avoided at changing of cassette tape if only the Record Head azimuth is properly adjusted in advance.

The Fig. 2.1.2 shows trackings of each head against a tape of the N-481, wherein the figure shows ideal locations at the time of designing, thus the tracking in actual use will vary more or less, depending upon the tape width, etc.

(1) Adjustment of Tape Guide Height

Tape Guide of the N-481 is assembled into the Take-up and Supply Pressure Roller Assemblies. With a spring in the stud of Mechanism Chassis Ass'y, Pressure Roller Ass'y is tightly affixed with Tape Guide Adjustment Nut. The Adjustment Nut is placed on a spring through Pressure Roller Arm, and therefore by either tightening or loosening, height adjustment of the Tape Guide will become possible.

(2) Playback Head Height Adjustment and Azimuth Alignment

Azimuth and height of Playback Head can be made independently and adjustment may be done separately without affecting others. In order to adjust the tilt of Playback Head backwards or frontwards, take off the Height Gear Stopper and take out the Height Gear and then turn the two Height Adjustment Screws. After the adjustment is done, place the Height Gear back and fix it with the Height Gear Stopper. After the tilt is adjusted in such a way as above, adjust the height by loosening or tightening the Height Gear. Azimuth alignment is adjusted by loosening or tightening the PH Azimuth Screw. This system has been carefully designed so as to minimize influence each other between azimuth and height adjustment.

(3) Record Head Height Adjustment and Azimuth Alignment

Record head tilt adjustment can be performed in the same way as for the Playback Head. Height adjustment can be adjusted while recording 400 Hz test tone by loosening or tightening RH Height Adjustment Screw to obtain the maximum level on the both Level Meters. Azimuth alignment can be adjusted while playing back 15 kHz signal by loosening or tightening RH Azimuth Alignment Screw to obtain the maximum

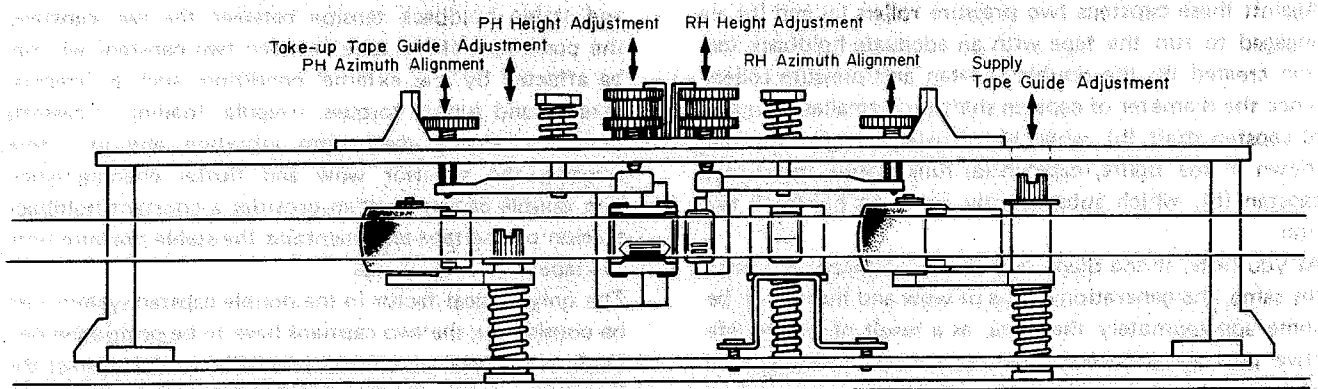

Fig. 2.1.1 Headblock

level on the both Level Meters. This system has also been carefully designed so as to minimize influence each other between azimuth and height adjustment.

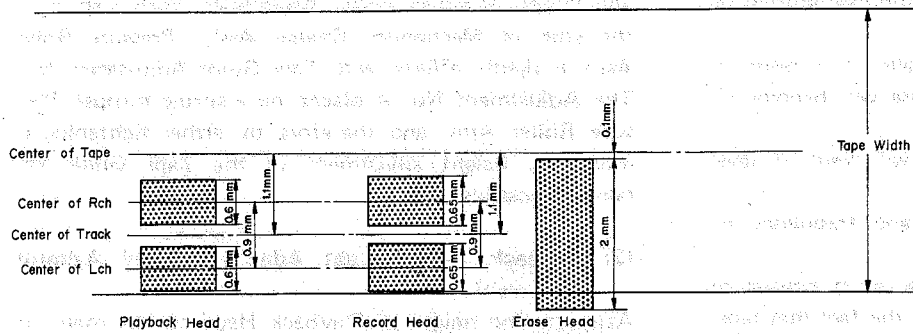

Fig. 2.1.2 Trackings

2.1.2. Erase Head

Fig. 2.1.3 shows the sectional view of the Erase Head. Fig. 2.1.4 shows the characteristics of erasing current and erasure.

It has the same characteristics with the previous type Direct-Flux Erase Head but been purposely developed to minimize the size further.

Conventional Erase Head had its inside core narrower than its outside core, while this Erase Head is equipped with an inside core wider than the outside core. This has resulted more power sufficient enough for erasing with small power consumption, approx. 0.5 W, though the head width is as small as 3 mm. The smaller the power consumption is, the smaller will be the heat generation, and this is of course another merit.

2.1.3. Double Capstan Tape Drive

As shown in Fig. 2.1.5, the double capstan system consists of two capstan shafts (a) and (b) connected to the two flywheels which are driven by a capstan belt.

Against these capstans two pressure rollers (a) and (b) are engaged to run the tape with an adequate holdback tension created by the double capstan and pressure rollers. Since the diameter of capstan shaft (a) is smaller than that of capstan shaft (b), when two flywheels begin to turn as shown in the figure, capstan (a) runs slightly faster than capstan (b), which subsequently generates holdback tension.

As you note, if the diameters of the 2 capstans should be the same, the generation cycles of wow and flutter will become approximately the same, as a result of which defective portion will be doubly superposed and preferable portion vice versa. The N-481 employs 2 capstans, each having different diameter and rotations, thereby avoiding

(4) Erase Head Height and Tilt Adjustment

Erase Head is affixed onto the Erase Head Plate which is assembled with the Head Base. It is installed with three screws. By turning these screws, its height, tilt of backward or forward, and tilt of leftward or rightward can be adjusted separately, thus the best location of Erase Head can be obtained.

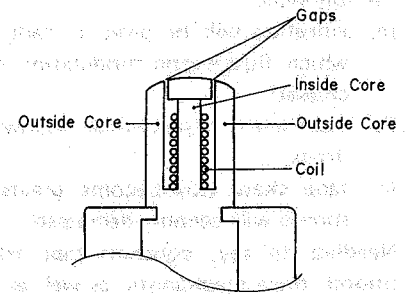

Fig. 2.1.3 Sectional View of Erase Head

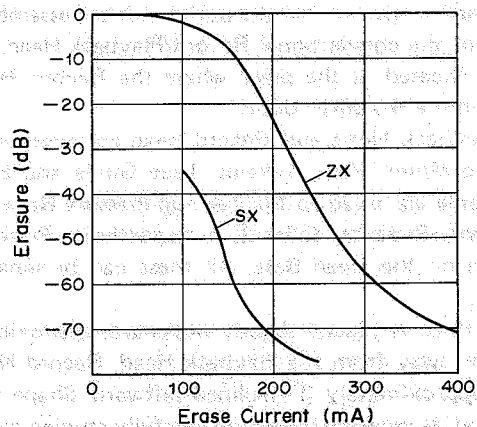

Fig. 2.1.4 Characteristics of Erasing Current and Erasure

the aforesaid occurrence and stabilizing wow and flutter characteristics.

As the double capstan system always creates a constant and stable holdback tension between the two capstans, the condition of the tape between two capstans will not be affected by any external conditions such as irregular take-up and supply torques, irregular loading of cassette tape, undesirable mechanism vibration and etc., thus assuring the superior wow and flutter characteristics. The double capstan system provides a constant holdback tension on the tape and maintains the stable pressure onto the tape against the heads.

The only critical factor in the double capstan system is to be considered; the two capstans have to be positioned perfectly in parallel and to be precisely vertical against the head base, the pressure rollers have to be evenly pressed against the capstan shafts and the head surface must be

positioned perfectly vertical to the tape surface. Otherwise, the running tape might become out of the tape guide resulting in irregular movement.

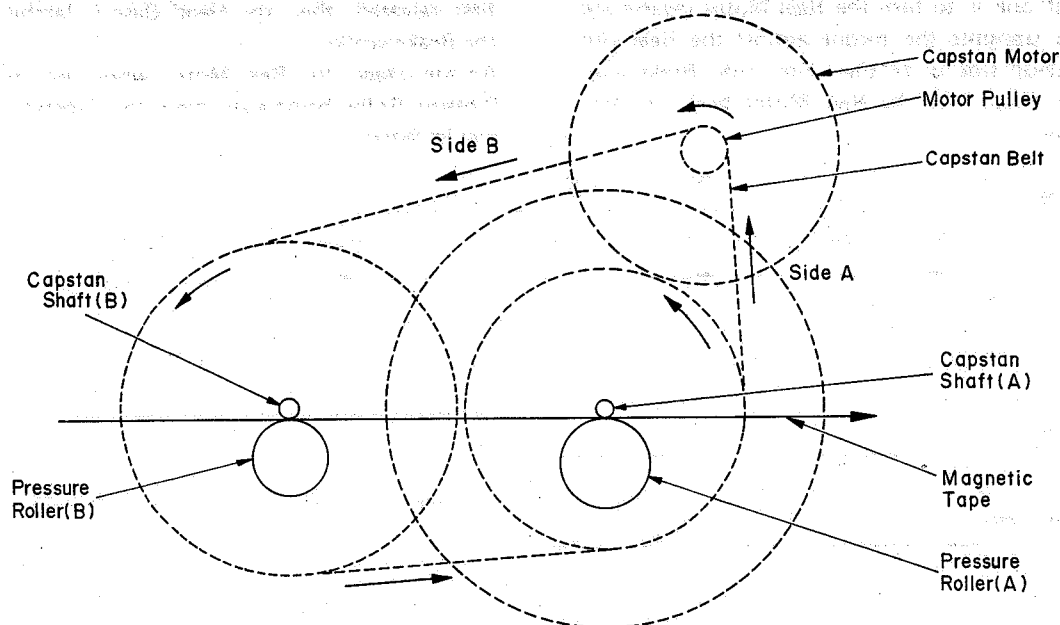

Fig. 2.1.5 Double Capstan Tape Drive

2.1.4. Mechanism Control Cam Operation

Refer to Fig. 2.1.6 Mechanism Control Cam timing chart. Function of N-481 Mechanism is done by Cam Control. Cam is driven by the Control Motor. The Motor operates so as to result zero in the difference of voltages between each voltage corresponding to mechanism function and each reference voltage which corresponds to each commands of the Control Switch. When the difference comes to zero, then it stops. In this way, each function is kept properly operated. For further details, please see the explanation on Logic Control. Here we explain principle of its mechanical functions.

Cam Control System works as follows: Cam Drive Gear is driven by Control Motor by means of Drive Belt. Cam Drive Gear is related to the cam with which each function may be mechanically set on.

(1) Play Mode

Press the Play Switch to make it Play mode. Then the Cam begins to move from Stop position to Play position and the Play mode will be set.

The Head Base which is linked to the Cam and which is normally pushed against the Stop position gets released and the Head Base will slowly come out for playing. To explain this function, first the Head Base is latched and the Reel Motor begins to turn. Then the Pressure Roller

will be pushed and the Brake will be released. Now the tape begins to run. If you press the Pause Switch at this stage, it comes to Pause mode. Brake operates and the Pressure Roller moves away from the Capstan and the Reel Motor stops.

Play mode may be changed to Stop mode by pressing the Stop Switch, and latch of the Head Base being released. The Cassette Case cannot be opened because of the latched eject effect unless it is in Stop mode.

(2) Record Mode

By pressing the Record Switch and the Pause or Play Switch, it may be made to Record mode. The Cam at this moment moves from Stop position to Rec. position. At the same time, Rec. Trigger Mechanism is driven and the Record Switch on the Main P.C.B. is switched on to the Record side. Further, the Cam turns until it comes to the Pause or Play position. On the other hand, the Rec. Trigger Mechanism is released during this process. When the Cam is set in Rec./Pause or Rec./Play position, Record signals will be sent to Bias Oscillating Circuit from Logic Control Circuit to let the Bias to oscillate. Press the Stop Switch and the Cam comes back to the Stop position. At the same time, it will set the Record Switch on the Main P.C.B. to the Play side.

(3) F.F. or Rewind Mode

By pressing the F.F. or Rewind Switch, it comes either to F.F. or Rewind mode. The only difference of these two modes is that one is to turn the Reel Motor reverse and the other to transmit the torque against the Reel Hub onto the take-up side or to the supply side. Brake is released at this stage and the Reel Motor begins to turn F.F. or Rewind.

(4) Pause Mode

Press the Pause Switch to make it to Pause mode. In changing it from Stop mode to Pause mode, the Brake is first released, then the Head Base is latched, and again the Brake works. At this stage, the Reel Motor would not turn with the Pressure Roller being apart from the Capstan, and the tape would remain still.

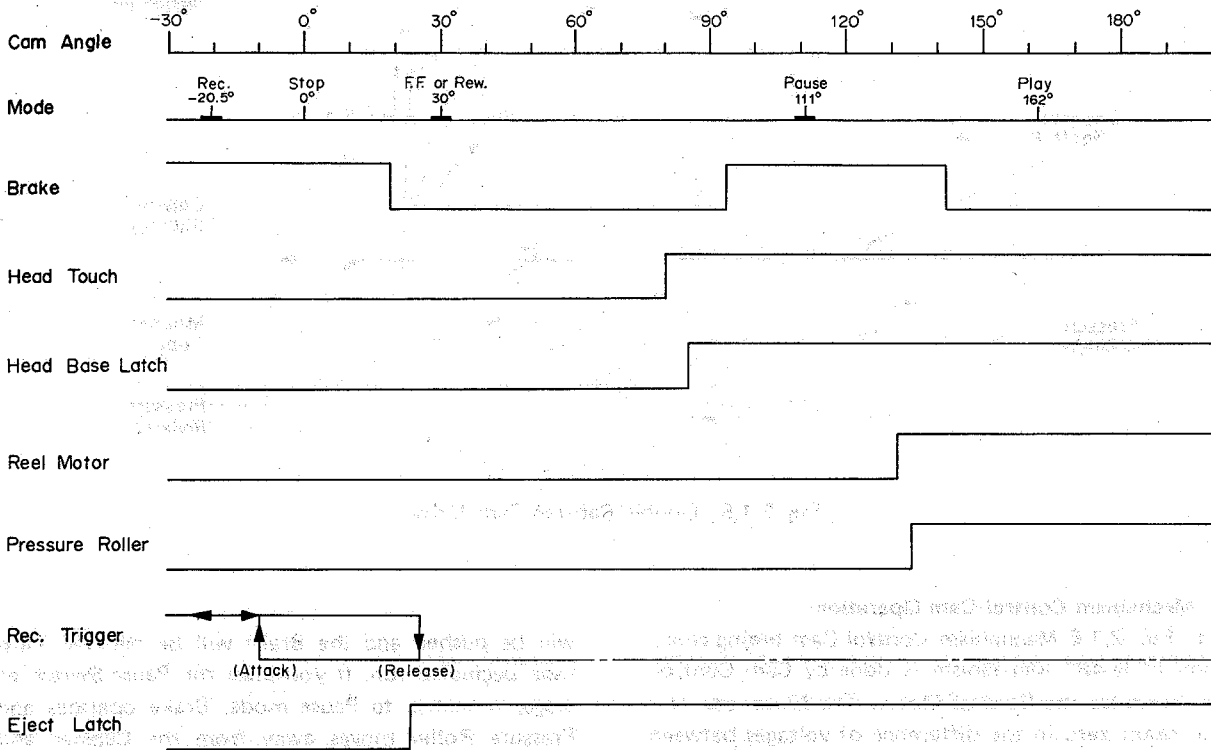

Fig. 2.1.6 Mechanism Control Cam Timing Chart

2.2. Amp. Circuits

2.2.1. Playback Eq. Amp. Circuit

Fig. 2.2.1 shows the playback equalizer amp. circuit. Fig. 2.2.2 shows its system diagram, and Fig. 2.2.3 shows the time constant of equalizer. Playback Head is connected to the input of this circuit. Amplifier, which is composed of Q101 and Q102, is an equalizer amplifier and its time constant is shown in Fig. 2.2.3. R111, R112, L101 and C109, which consist of a peaking circuit, compensate playback head gap loss and improve frequency response at high. L101 and C186 compose a bias trap circuit and prevent bias leakage from playback eq. amp. circuit. Playback eq. amp. gain adjustment should be performed so as to obtain 100 mV at TP101 (TP201) by adjusting VR101 (VR201) during the course of playing back 400 Hz Level Tape (DA09005A). Eq. Switch (70 μs/120 μs) is connected to the playback eq. amp. circuit and the overall time constant of playback eq. amp. circuit will become as follows:

Eq. Switch — 70 μs: 3180 μs (50 Hz) + 70 μs (2274 Hz)

Eq. Switch — 120 μs: 3180 μs (50 Hz) + 120 μs (1326 Hz)

Following table shows tapes used at each Tape Switch combined with Eq. Switch.

Tape SW	Eq. SW	Tape
ZX	70 μs	Nakamichi ZX
SX	70 μs	Nakamichi SX, TDK SA, Maxell XL-II, Scotch Master 70 μs
EX	120 μs	Low-Noise High-Density (including EX, EXII, TDK AD, Maxell XL-I, Scotch Master 120 μs)
	70 μs	Nakamichi EX, EXII

It is specified in the IEC Standard that the time constant is 120 μ s on tapes of ferric oxide, and 70 μ s on tapes of CrO₂.

However, in the case of Eq. Switch on N-481, when time constant at playback is changed, at the same time time constant at record must also be changed. Therefore, even though record and playback is made by the method other

than the IEC Standard, no deterioration of frequency response or level difference will occur. (Any other method for instance, record and playback on ferric oxide tape with putting Tape Switch on EX and Eq. Switch on at 70 μ s.) When Nakamichi EX or EXII Tape is used at Tape Switch: EX, and Eq. Switch: 70 μ s, S/N ratio will be improved by approximately 4 dB (WTD).

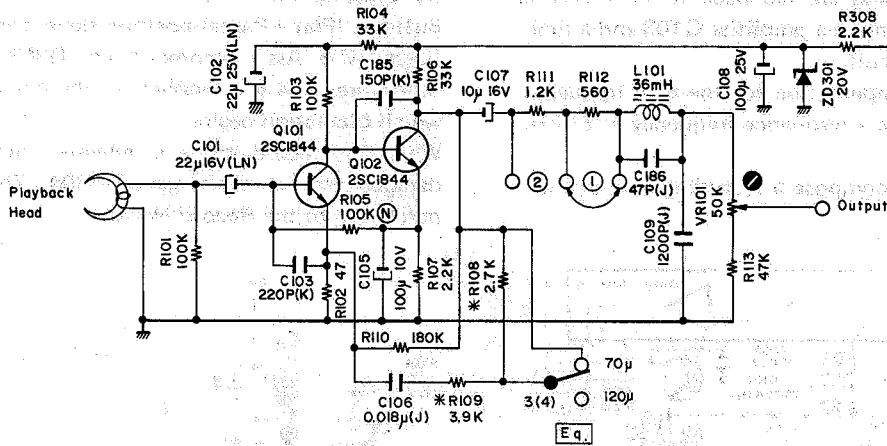

Fig. 2.2.1 Playback Eq. Circuit

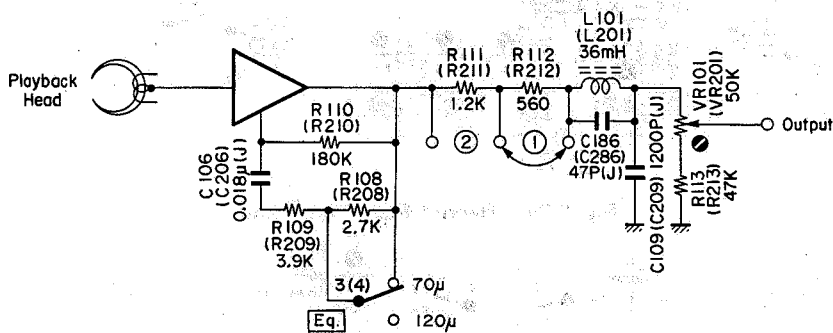

Fig. 2.2.2 System Diagram

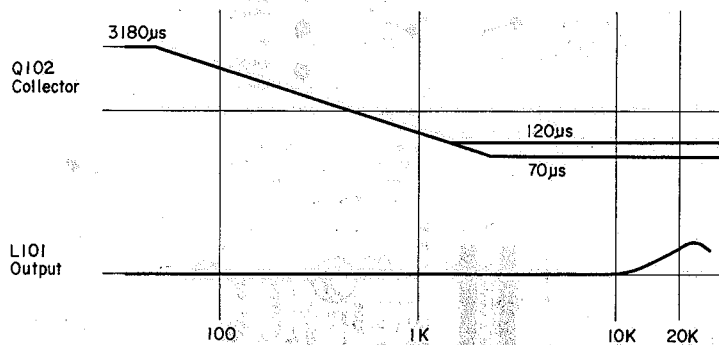

Fig. 2.2.3 Time Constant

2.2.2. Record Equalizer Amplifier Circuit

The record equalizer amplifier circuit consists of the Output Amp. incorporated in the Dolby NR IC and peripheral circuits as shown in Fig. 2.2.4.

VR102, VR103, and VR104 are the record calibration semi-fixed volumes for ZX, SX and EX tapes. The output of the Output Amp. is given to these volumes, and the outputs from the volumes are fed back to the inverting input of the Output Amp. via amplifier Q103 and a time-constant changeover circuit.

By adjusting L104, compensation for the high frequency range is made by setting a resonance frequency at 21 kHz or neighborhood.

L105, C138 and C139 compose a recording bias trap circuit.

2.2.3. Bias Oscillation Circuit

Fig. 2.2.5 shows a push-pull oscillator with an oscillation frequency of 105 kHz which is constructed by capacitors C302 and C303, coupling the collectors and bases of two transistors (Q301 and Q302).

This is used to provide recording bias and as an erase signal.

By pressing the Record and Pause, or Record and Play Buttons, (Play + Pause)-position signal conducted from the Logic P.C.B. Ass'y becomes H and Q303 turns to ON.

Therefore, +24 V is applied to the circuit, as a result of which oscillation begins.

When the record mode is released, oscillator output is damped by the discharge of C304. This prevents magnetization of the Record Head.

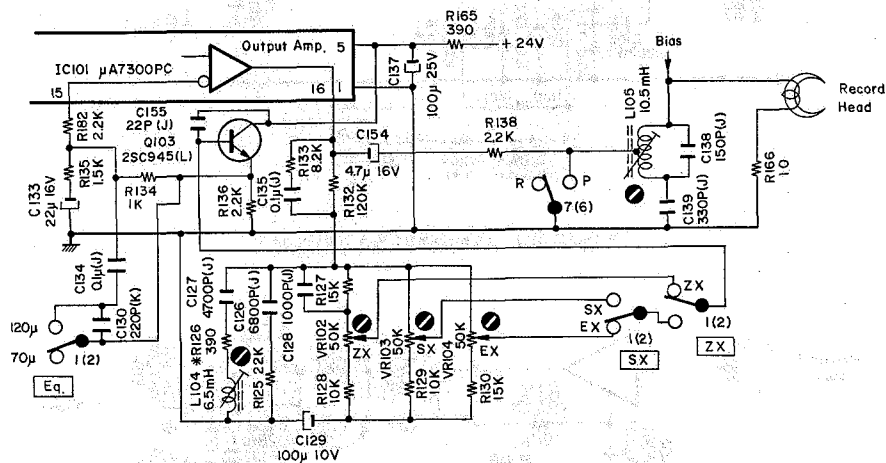

Fig. 2.2.4 Record Eq. Amp. Circuit

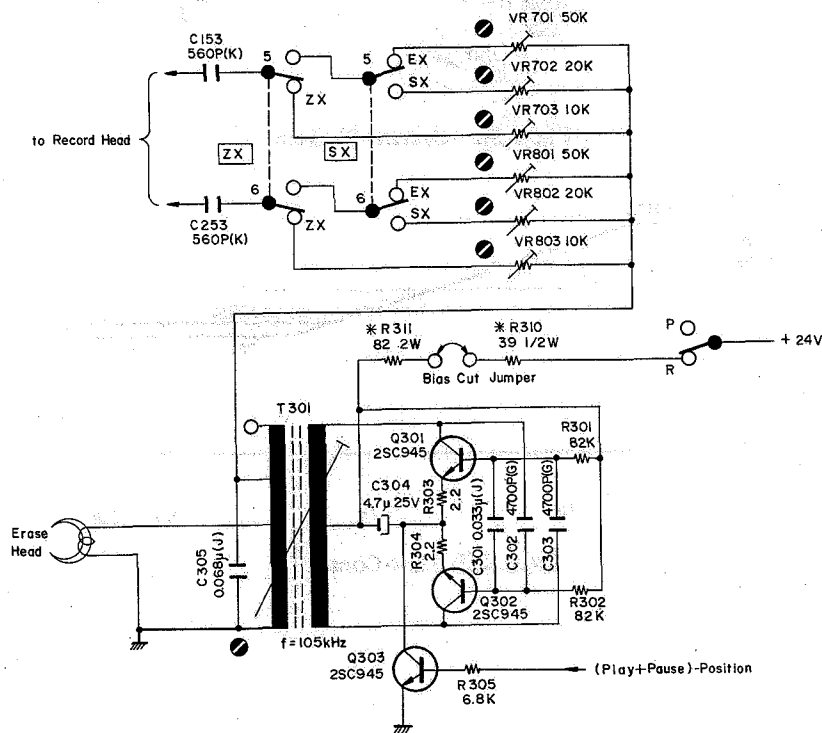

Fig. 2.2.5 Bias Osc. Circuit

2.3. Mechanism Control Circuits

2.3.1. Outline

(1) Control Button Operation

Record, Rewind, Stop, Play, and Fast-Forward Buttons consist of a 5-way switch and are interlocked each other. When one button is pressed, it is mechanically locked in the ON state and other buttons are mechanically released. Stop Button is of momentary type and acts to release other buttons mechanically. But it is not used to control circuits electrically. Pause Button is independent from others and is of push-on and push-off type. Note that if two or more buttons are pressed simultaneously, these buttons are locked in the ON state. Under the normal control button operation, only Record and Play Buttons are pressed simultaneously to set the N-481 in RECORD mode. In this case, both Record and Play Buttons are locked in the ON state and RECORD mode is set. The N-481 is designed so as not to occur erroneous operation even if two or more buttons are pressed simultaneously. Further, to prevent from abnormal tape tension, loosening of tape, etc., the N-481 changes its mode by passing through momentary STOP mode automatically, for example, when PLAYBACK mode is commanded while FF mode, or REW mode is commanded while FF mode.

(2) Auto Shut-off Function

Refer to Fig. 2.3.1 basic circuit diagram.

During FF, REW, or PLAY (PLAYBACK or RECORD)

mode, auto shut-off will be activated when the tape comes to end, and FF, REW, or PLAY mode is changed to STOP mode.

Following explanation is made in regard to REW mode:

In the initial condition, Q428 is turned ON and +24 VS is applied to the emitter of Q402. When Rewind Button is pressed, it is locked in the ON state, as a result, Q402 is turned ON, the REW signal becomes H, and the N-481 is set in REW mode.

When tape-end comes, auto shut-off is activated and Q428 is turned OFF, as a result, +24 VS is shut-off, Q402 is cut off, and the REW signal becomes L. In this way, REW mode is changed to STOP mode. (Note that Rewind Button is still locked in the ON state.) When Play Button is pressed in this state, REW Button is released and Q428 is turned ON, as a result, +24 VS is applied again, Q418 is turned ON, the PLAY signal becomes H, and the N-481 is set in PLAY mode.

(3) Unattended Recording or Playback

Unattended recording or playback is carried out by the use of the lock mechanism of control button, therefore, no special circuit is required for this purpose.

If Record and Play Buttons are pressed, unattended recording can be carried out when the power is connected to the N-481. If only Play Button is pressed, playback will be carried out when the power is connected to the N-481.

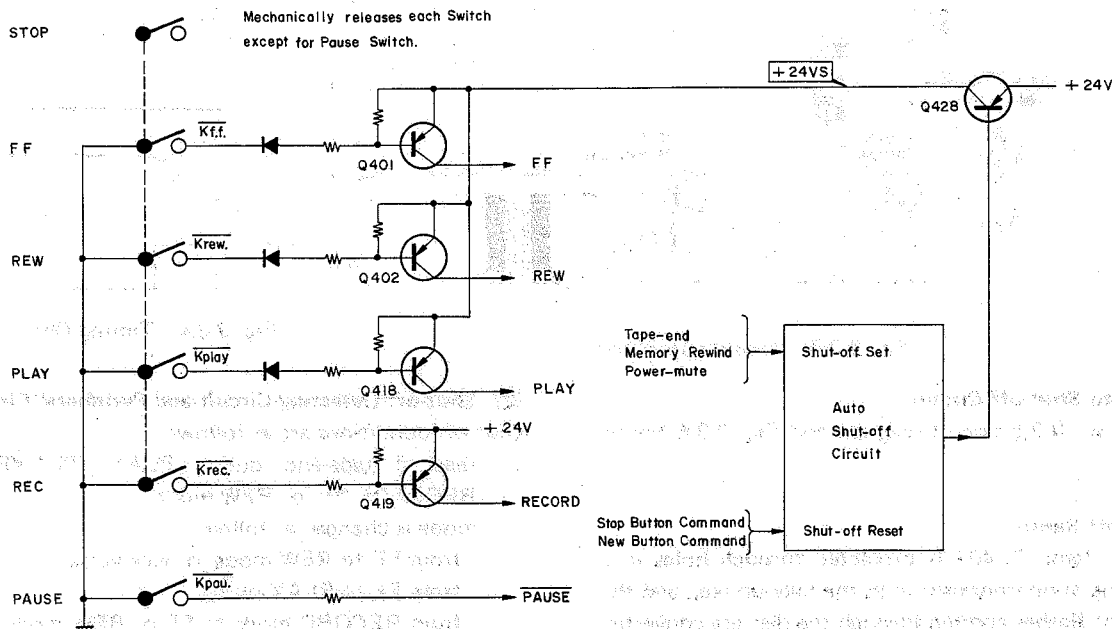

Fig. 2.3.1 Basic Auto Shut-off Circuit

2.3.2. +12 V Power Source

Refer to Fig. 2.3.2 circuit diagram. Only +24 V DC power supply is used in the N-481. The circuit acts to produce a +12 V power source from the +24 V DC power supply. Mechanism control is done by using thus produced +12 V.

2.3.3. Power-mute Signal

Refer to Fig. 2.3.3 circuit diagram and Fig. 2.3.4 timing chart. Power-mute = L signal is produced pulse-likely when Power Switch is turned ON or OFF. This L pulse mutes the amp. circuit and also acts to shut off the shut-off circuit initially.

(1) Power Switch ON

Q433 is turned ON at every positive half cycle of the output from the secondary winding of the power transformer. When Q433 is turned ON, C416 is discharged, as a result, the voltage of C416 can not exceed the VBE of Q432, and Q432 is in the cutoff state.

Therefore, the Power-mute = L pulse is produced for a certain period of time when +24 V is built up after Power Switch is turned ON.

The Power-mute = L signal makes Q416 to turn ON, as a result, Mute signal becomes H and the amp. circuit is muted.

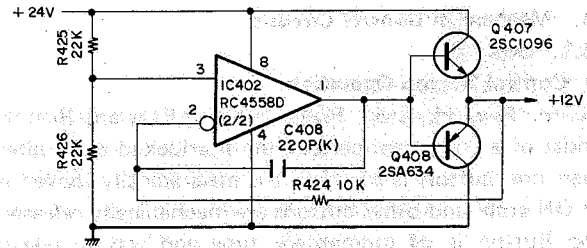

Fig. 2.3.2 +12 V Power Source Circuit

Meanwhile, the Power-mute = L pulse is applied to the shut-off circuit and shut-off is activated.

(2) Power Switch OFF

The output from the secondary winding of the power transformer ceases quickly, and Q433 is turned OFF. Consequently, the base current flows to Q432 through R481, Q432 is turned ON, and the Power-mute signal becomes L.

The Power-mute = L signal makes Q416 to turn ON, as a result, Mute signal becomes H and the amp. circuit is muted. At the same time, shut-off circuit is shut off by the Power-mute = L signal.

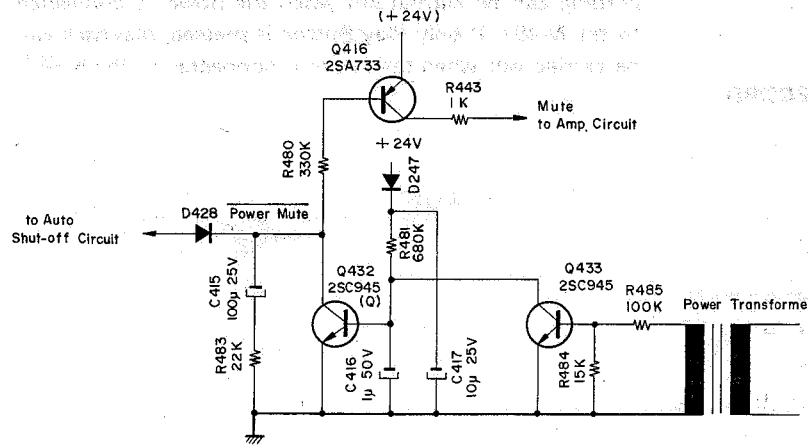

Fig. 2.3.3 Power-mute Circuit

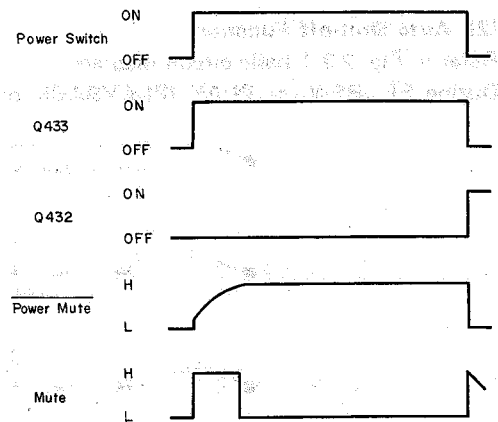

Fig. 2.3.4 Timing Chart

2.3.4. Auto Shut-off Circuit

Refer to Fig. 2.3.5 circuit diagram and Fig. 2.3.6 timing chart.

(1) Shut-off Sensor

Light from lamp PL407 is projected through holes in a disc rotating synchronously with the take-up reel, and the intermittent flashes coming through the disc are converted into electrical signals by a phototransistor Q450. These signals are amplified into square waves, and transmitted to the shut-off detecting circuit in the subsequent stage. When the tape-end comes, the take-up reel and the disc stops rotating, and no pulse is output from the sensor.

(2) Shut-off Detecting Circuit and Peripheral Circuits

Shut-off conditions are as follows:

- reached tape-end during PLAY (PLAYBACK or RECORD), FF, or REW mode
- mode is changed as follows:
 - from FF to REW mode, or vice versa
 - from FF to PLAY mode
 - from RECORD mode to FF or REW mode

When the mode is changed, shut-off is momentarily activated and the mode is changed to STOP mode in a short period of time, and after this STOP mode is over, a new mode is set.

- Power-mute = L pulse is generated when Power Switch is turned ON or OFF
- memory rewind function is activated.

(a) Reached tape-end during PLAY (PLAYBACK or RECORD), FF, or REW mode

Explanation is made for PLAY mode as an example. For FF or REW mode, the shut-off function is the same as for PLAY mode.

As Play Button is locked ON mechanically, $K_{play} = L$. Accordingly, R488 (100 kΩ) is grounded through Play Button and the voltage at the point A becomes approx. +23 V. Since the voltage at the point A is not lower than the emitter voltage of Q424, Q424 is turned OFF and Q426 is also turned OFF. (Q424 and Q426 will be turned ON when the voltage at the point A is further lowered as described in subsequent (b).)

Q425, Q427, Q430, R470 and C412 consist of a shut-off detecting circuit. During PLAY mode, the voltage at the point A is approx. +23 V, therefore, Q425 is turned ON and C412 (2.2 μF) is charged toward +24 V through R470.

Meanwhile, pulses from the shut-off sensor are applied to the base of Q427 through R489 and C418, and, at every H cycle of the sensor output pulse, Q427 is turned ON and C412 is discharged through Q427. When the tape-end is detected, pulses from the shut-off sensor are not transmitted and Q427 is turned OFF, resulting in C412 being charged continuously.

When the voltage of C412 exceeds the sum of the emitter voltage (approx. 5.5 V) and the VBE of Q430, Q430 is turned ON and the base current flows to Q429. Consequently, Q429 is turned ON, Q428 is cut off, +24 VS is shut-off, PLAY mode is changed to STOP mode, and play lamp goes out.

Q430, Q429, Q428, R476, R474, R456 and C420 consist of a Schmitt circuit which provides hysteresis characteristics for ON/OFF of Q430. Accordingly, Q430 will be

turned ON or OFF without chattering for the input waveform with a large time constant developed across C412. If Pause Button is pressed during PLAY mode, tape stops and no pulse is transmitted from the shut-off sensor; but Q427 is kept ON since Q423 is turned ON during PLAY-PAUSE mode, therefore, no charge is made at C412 and shut-off is not activated.

When shut-off is made at the tape-end during PLAY mode, PLAY mode is changed to STOP mode.

If Stop Button is further pressed, Play Button will be released and the voltage at the point A returns to +24 V as R488 is released from grounding, as a result, Q425 is turned OFF and C412 is discharged quickly through D423 and R467 (10 kΩ). Accordingly, Q430 is turned OFF, Q429 is turned OFF, Q428 is turned ON, and +24 VS is again applied preparing for the next control button operation.

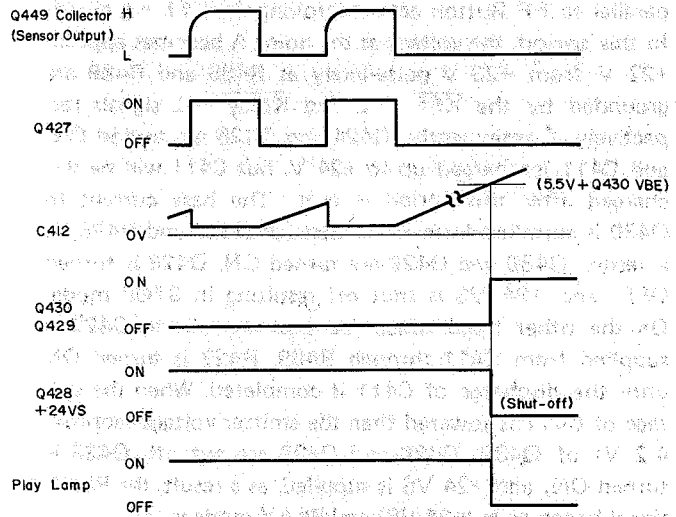

Fig. 2.3.6 Timing Chart

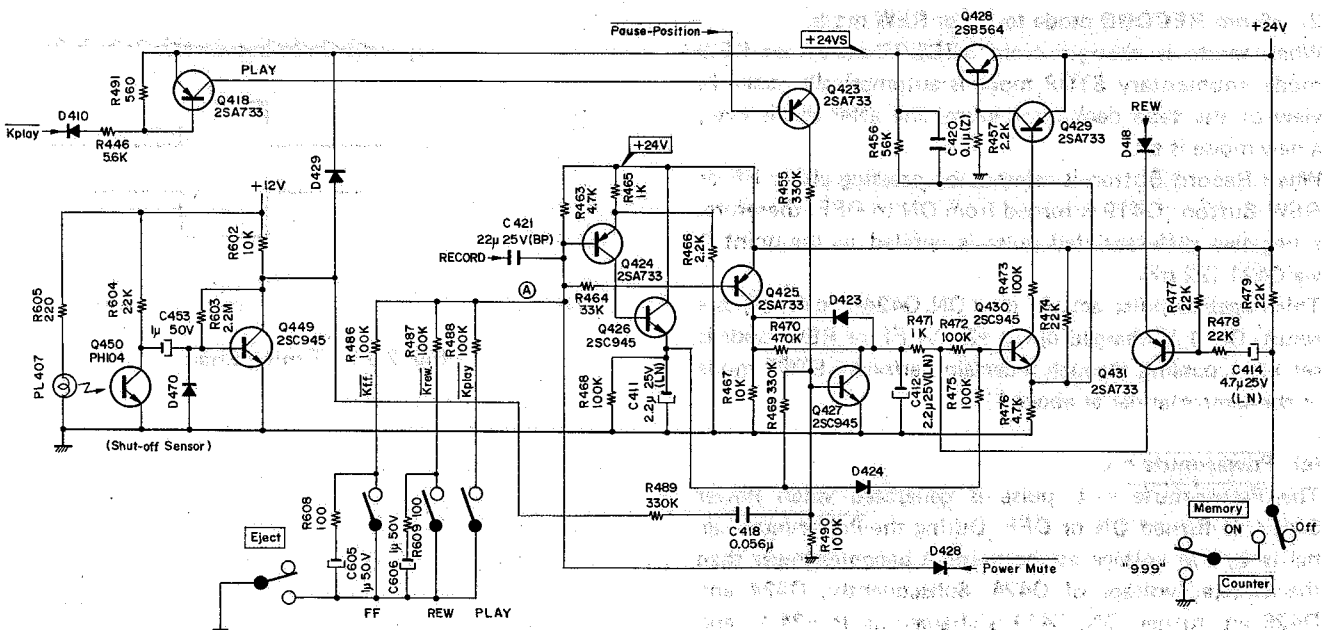

Fig. 2.3.5 Auto Shut-off Circuit

(b) Mode is changed

1) From FF to REW mode, or vice versa, or from FF to PLAY mode

Refer to Fig. 2.3.7 timing chart.

When mode is changed from FF to REW mode, or vice versa, or from FF to PLAY mode, momentary STOP mode is automatically taken in view of the response of the tape deck mechanism, and after this is over, a new mode is set.

The following explains in regard to the case when FF mode is changed to PLAY mode by pressing Play Button during FF mode:

During FF mode, R486 (100 kΩ) is grounded by the $\overline{Kf.f.} = L$ signal. When Play Button is pressed, it is locked ON and FF Button is released. Although FF Button is released, the $\overline{Kf.f.}$ signal is kept L for a short period of time because the delay circuit (C605 and R608) connected in parallel to FF Button acts to prolong the $\overline{Kf.f.} = L$ signal. In this period, the voltage at the point A becomes approx. +22 V from +23 V pulse-likely as R486 and R488 are grounded by the $\overline{Kf.f.} = L$ and $\overline{Kplay} = L$ signals respectively. Consequently, Q424 and Q426 are turned ON, and C411 is charged up to +24 V, but C411 will be discharged after this period is over. The base current to Q430 is supplied from C411 through D424 and R475, as a result, Q430 and Q429 are turned ON, Q428 is turned OFF, and +24 VS is shut off resulting in STOP mode. On the other hand, since the base current to Q427 is supplied from C411 through R469, R427 is turned ON until the discharge of C411 is completed. When the voltage of C411 is lowered than the emitter voltage (approx. 4.2 V) of Q430, Q430 and Q429 are cut off, Q428 is turned ON, and +24 VS is supplied, as a result, the PLAY signal becomes H (+24 VS) and PLAY mode is set.

2) From RECORD mode to FF or REW mode

When mode is changed from RECORD to FF or REW mode, momentary STOP mode is automatically taken in view of the tape deck mechanism, and after this is over, a new mode is set.

When Record Button is released by pressing either FF or REW Button, Q419 is turned from ON to OFF, therefore, a negative differentiated pulse is applied to the point A via C421 (22 μF).

This negative pulse acts to turn ON Q424 and Q426, as a result, C411 is charged up to +24 V. FF or REW mode is set after passing through a certain period of STOP mode in the same manner as above 1).

(c) Power-mute = L

The Power-mute = L pulse is generated when Power Switch is turned ON or OFF. During the Power-mute signal is L, the voltage at the point A becomes lower than the emitter voltage of Q424. Subsequently, Q424 and Q426 are turned ON, C411 is charged up to +24 V, and shut-off is activated in the same manner as above (b).

(d) Memory Rewind

During REW mode and with Memory Rewind Switch turned ON, C414 is grounded when the tape counter comes to "999", and Q431 is turned ON pulse-likely.

As a result, Q430 is turned ON, and shut-off is activated resulting in STOP mode.

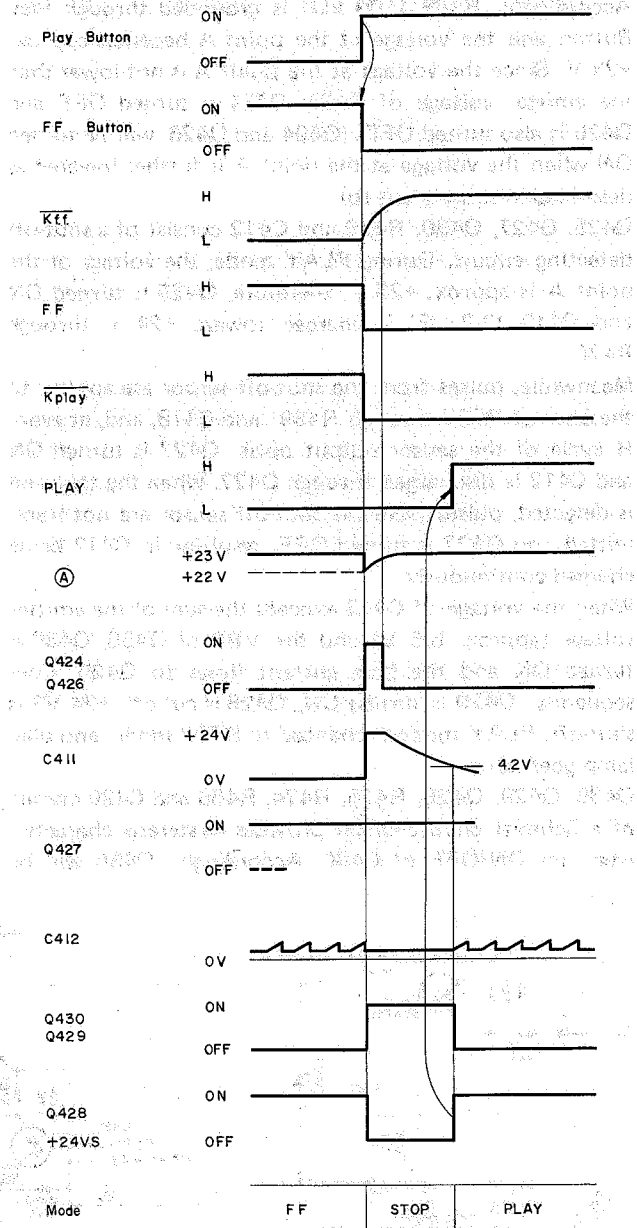

Fig. 2.3.7 Timing Chart

2.3.5. Record Control Circuit

Refer to Fig. 2.3.8 circuit diagram.

RECORD mode is set by pressing Record Button, then Play Button together. By pressing Record Button, the \overline{Krec} signal becomes L, Q419 is turned ON, Q421 is turned ON, and the record lamp is illuminating. Then, by pressing Play Button further, the \overline{Kplay} signal becomes L, Q418 is turned ON, the PLAY signal becomes H (+24 VS), and Q420 is turned ON.

Accordingly, the base current flows to Q403 via C406 connected to the base of Q403, and Q403 is turned ON pulse-likely.

The output of Q403 is fed to the control motor drive circuit and acts to bring the cam to the record position.

When Q403 returns to OFF, the cam then moves to the

play position and stays there, thus the mechanism is set to RECORD mode.

Record circuit is designed to protect from the erroneous setting of RECORD mode even if wrong record button operation is made.

Q422 is turned ON during FF or REW mode, or when the cam is set to the play or pause position, i.e., PLAY or PLAY/PAUSE mode. In this case, as D422 is grounded by Q422, Q421 is not turned ON and the record lamp is not lit even if Record Button is further pressed.

Further, the base of Q420 is grounded via D419 and Q422, consequently, Q420 and Q403 are not turned ON and no pulse is output from Q403 to the control motor drive circuit.

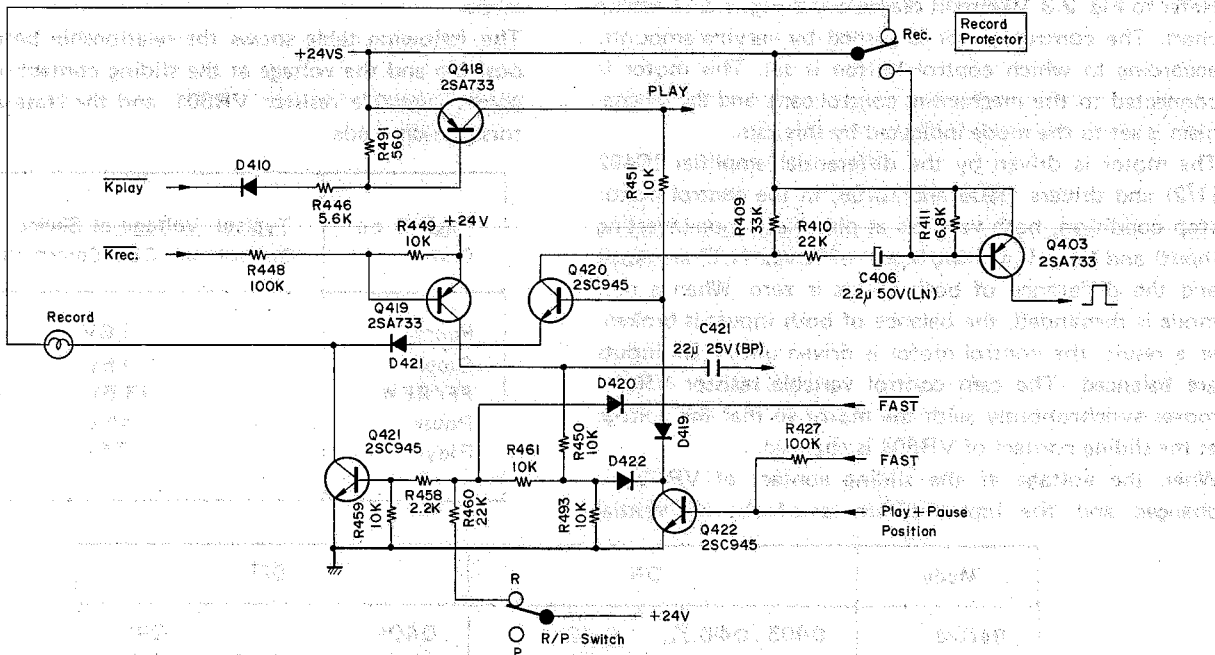

Fig. 2.3.8 Record Control Circuit

2.3.6. Mute Signal

Refer to Fig. 2.3.9 circuit diagram.

When Q416 is turned ON, the Mute = H signal is fed to the amp. circuit and the amp. circuit is muted.

The condition that the amplifier circuit is muted are (Mute = H):

$$Q416 \text{ ON} = ((Q412 \text{ ON}) + \overline{\text{PLAY}}) \cdot (\text{R/P Switch} = \text{Play}) + \text{Power-mute}$$

Power-mute: When Power Switch is turned ON or OFF, Power-mute signal becomes L, i.e., Power-mute signal becomes H, and Q416 is turned ON.

Q412 ON : Cam is in the pause position.

Q412 OFF : Cam is in the play position (i.e., PLAYBACK or RECORD mode).

R/P Switch : When R/P Switch on the Main P.C.B. is in the record position, +24 V is applied, but when it is in the play position, no voltage is applied.

The modes in which the amplifier circuit is not muted are (Mute = L):

$$Q416 \text{ OFF} = \overline{Q416 \text{ ON}} \\ = \overline{((Q412 \text{ ON}) \cdot \text{PLAY} + (\text{R/P Switch} = \text{Play}) \cdot \text{Power-mute})} \\ = ((Q412 \text{ OFF}) \cdot \text{PLAY} + (\text{R/P Switch} = \text{Record})) \cdot \overline{\text{Power-mute}}$$

i.e., PLAYBACK mode and RECORD mode.

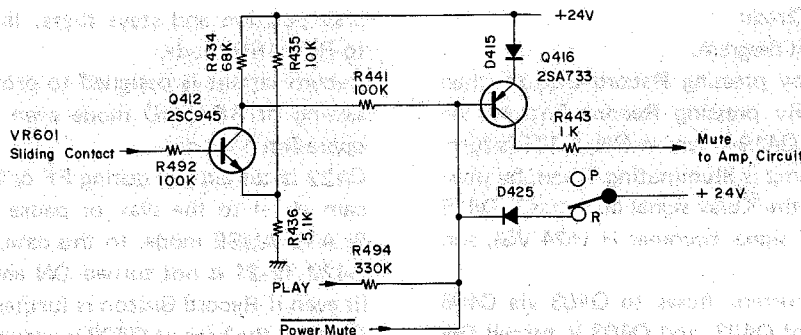

Fig. 2.3.9 Mute Signal Circuit

2.3.7. Control Motor Drive Circuit

Refer to Fig. 2.3.10 circuit diagram and Fig. 2.3.11 timing chart. The control motor is turned by varying amounts, according to which control button is set. This motor is connected to the mechanism control cam, and the mechanism is set to the mode indicated by this cam.

The motor is driven by the differential amplifier IC402 (1/2) and drivers Q405 and Q406. In the control motor stop condition, both voltages at pins No.5 (non-inverting input) and No.6 (inverting input) of IC402 (1/2) are equal and the difference of both inputs is zero. When a new mode is demanded, the balance of both inputs is broken, as a result, the control motor is driven until both inputs are balanced. The cam control variable resistor VR601 moves synchronously with the motor so that the voltage at the sliding contact of VR601 is changed.

When the voltage at the sliding contact of VR601 is changed and the input difference of the differential

amplifier IC402 (1/2) becomes zero, the control motor stops.

The following table shows the relationship between cam position and the voltage at the sliding contact of the cam control variable resistor VR601, and the state of transistors in each mode.

Position on Cam	Typical Voltage at Sliding Contact of Cam Control Volume
Record	16V
Stop	15V
FF/REW	13.5V
Pause	10V
Play	7.5V

Mode	ON		OFF	
	Record	Q403, Q410	Q412	Q404
Stop		Q412	Q403, Q404, Q410	Q411
FF/REW	Q404, Q410	Q412	Q403	Q411
Play, Pause	D417 ON	Q411, Q412	Q403, Q404, Q410	
Play		Q411	Q403, Q404, Q410	Q412

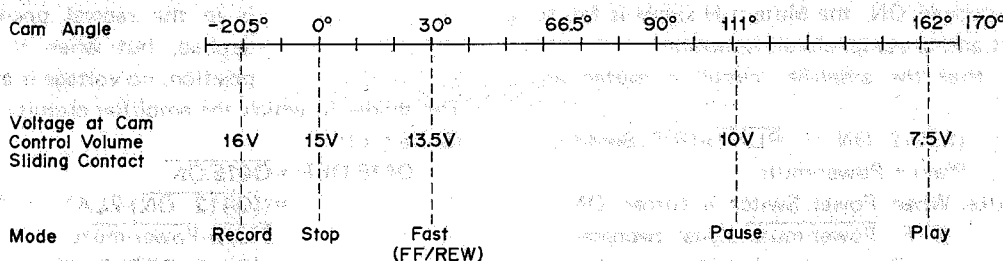

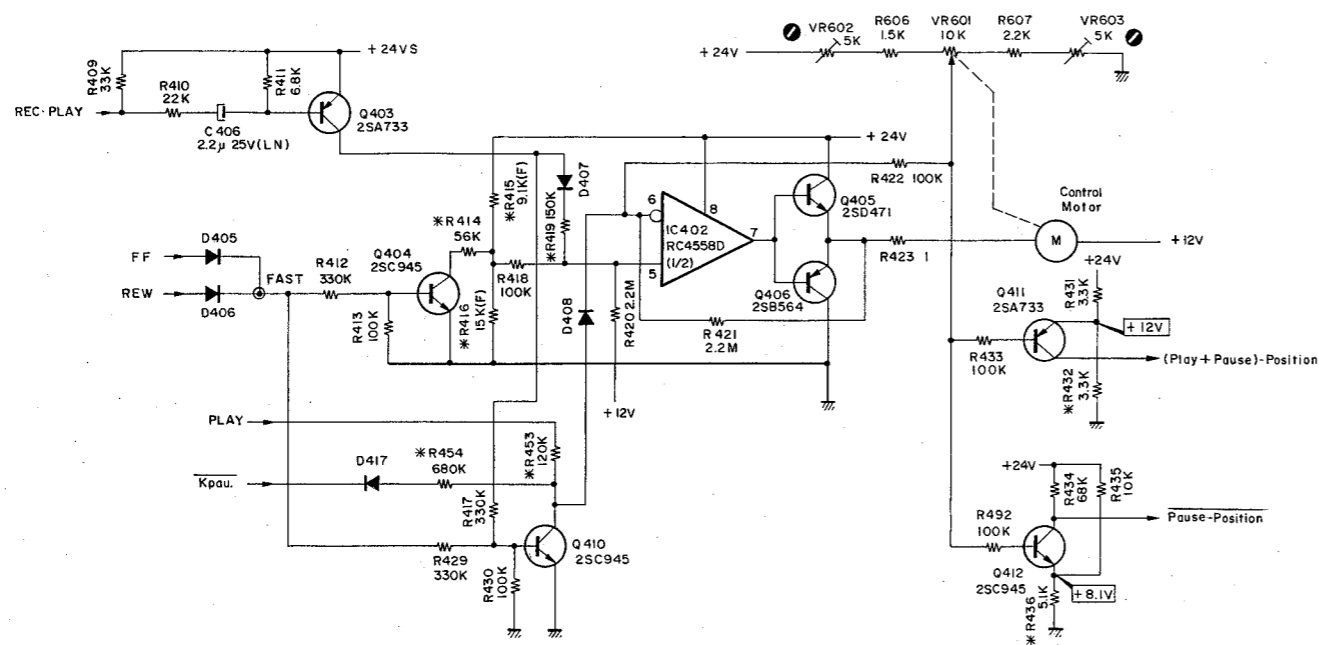

Fig. 2.3.10 Control Motor Drive Circuit

Control Button	STOP	PLAY	FF(REW)	PLAY	PLAY PAUSE	PLAY	STOP	REC/PLAY	REC/PLAY PAUSE	REC/PLAY	FF(REW)	STOP	FF(REW)
Mode	STOP							FF(REW)					
	STOP	PLAY	FF(REW)	PLAY	PLAY PAUSE	PLAY	STOP	REC-PLAY	REC-PLAY PAUSE	REC-PLAY	STOP	STOP	FF(REW)

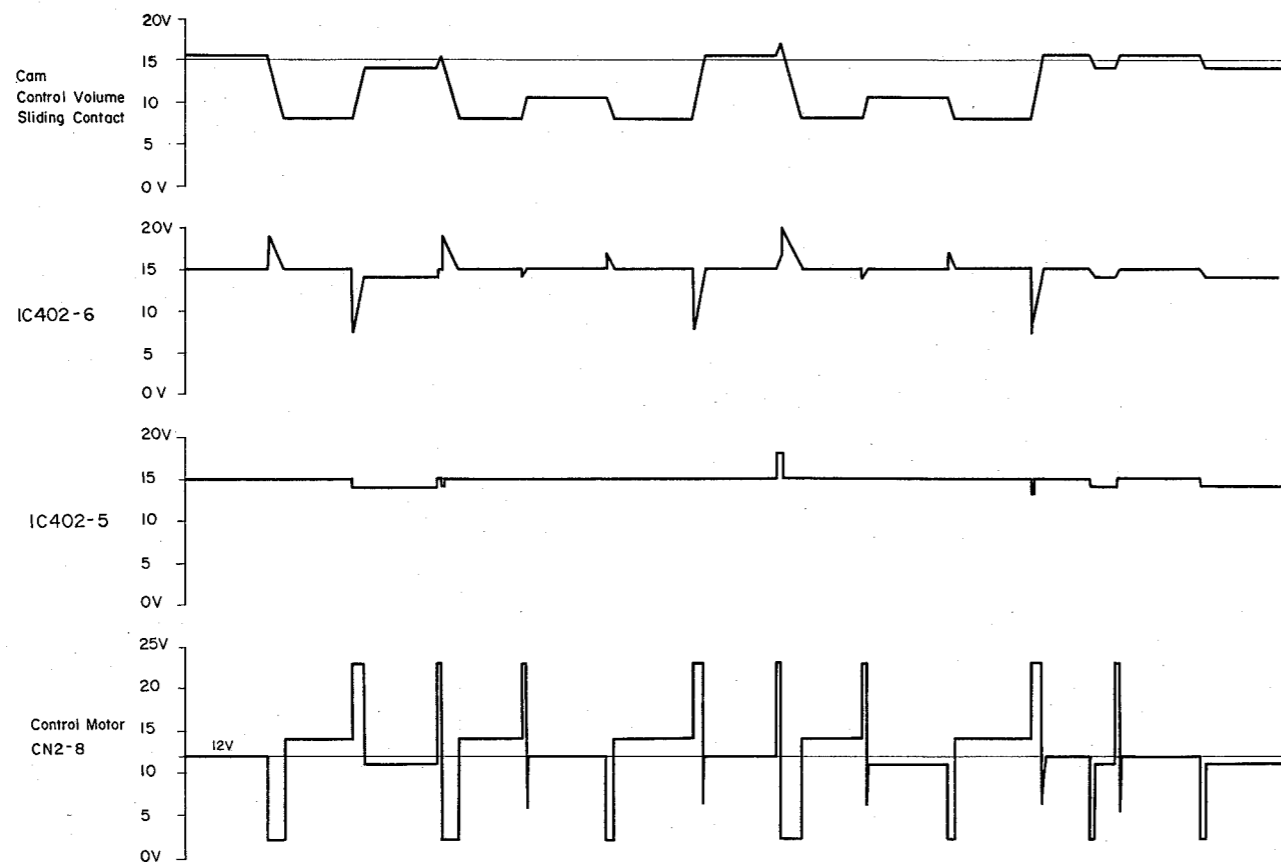

Fig. 2.3.11 Timing Chart

2.3.8. Reel Motor Governor

Refer to Fig. 2.3.12 circuit diagram.

One end of the reel motor is connected with +12 V and the other end is a terminal for controlling.

During FF mode, Q413 is turned ON and the reel motor is grounded. Accordingly, the reel motor turns in the direction of fast-forwarding. On the other hand, during REW mode, +24 V (REW = H) is applied to the reel motor and the reel motor turns in the direction of rewinding. During PLAY (PLAYBACK or RECORD) mode, Q412 is turned OFF and the Pause-position signal becomes H, as a result, Q417 is turned OFF and the reel motor is turned at a constant speed by the governor composed of Q414 and Q415.

During PLAY/PAUSE mode, Q412 is turned ON and the Pause-position signal becomes L, therefore, Q417 is turned ON, Q414 is biased in the reverse direction, and Q414 is cut off, thus the reel motor does not turn.

Take-up function at loading:

When a cassette tape is inserted and loaded, Eject Switch will become open. Consequently, the base current is applied to Q413 through C409, and Q413 is turned ON pulse-likely. During Q413 is turned ON, the reel motor turns in the direction of fast-forwarding and eliminates tape loosening of the cassette tape if any.

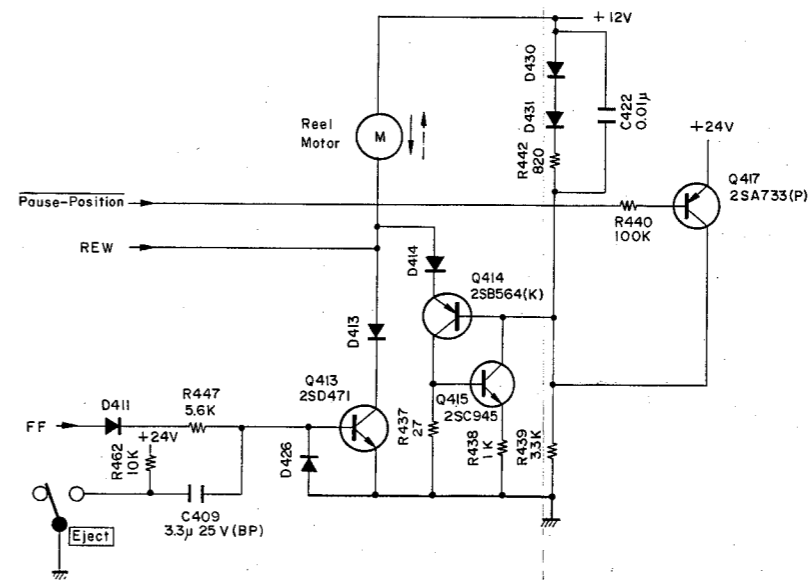

Fig. 2.3.12 Reel Motor Governor

3. REMOVAL PROCEDURES

3.1. Cassette Case Cover Ass'y

Refer to Fig. 3.1.

- (1) Press the Eject Button to open the Cassette Case Ass'y.
- (2) Pull out F01 (Cassette Case Cover Ass'y) upwardly.

3.2. Top Cover Ass'y

Refer to Fig. 3.1.

Remove F02 and F03, then disassemble F04 (Top Cover Ass'y).

3.3. Bottom Cover Ass'y

Refer to Fig. 3.1.

Remove F05, then disassemble F06 (Bottom Cover Ass'y).

3.4. Front Panel Ass'y

Refer to Fig. 3.2.

- (1) Refer to Fig. 3.1. Remove Top Cover Ass'y and Bottom Cover Ass'y referring to items 3.2 and 3.3.
- (2) Pull out F01 (Volume Knobs).
- (3) Remove F02 (Power Switch Joint Bar) by releasing the self-interlocking pin of the Power Switch Joint Bar from Power Switch, and turn F02 (Power Switch Joint Bar) by 90° either clockwise or counter-clockwise, then disassemble F02 (Power Switch Joint Bar) from the Power Switch Knob Ass'y.
- (4) Remove F03, then disassemble F04 (Front Panel Ass'y).

3.5. Headphone Jack Ass'y

Refer to Fig. 3.2.

- (1) Remove Front Panel Ass'y referring to item 3.4.
- (2) Remove F05, then disassemble F06 (Headphone Jack Ass'y).

3.6. Mechanism Ass'y

Refer to Fig. 3.2.

- (1) Remove Front Panel Ass'y referring to item 3.4.
- (2) Remove F07 and F08, then disassemble F09 (Mechanism Ass'y including 5 connectors and record switch linkage).

3.7. Meter Ass'y

Refer to Fig. 3.2.

- (1) Remove Front Panel Ass'y referring to item 3.4.
- (2) Remove F10 (Meter Ass'y) by releasing self-interlocking pins of the Meter Ass'y.

3.8. Lamp P.C.B. R Ass'y and Lamp P.C.B. L Ass'y

Refer to Fig. 3.2.

- (1) Remove Meter Ass'y referring to item 3.7.
- (2) Remove F11 (Lamp P.C.B. R Ass'y) and F12 (Lamp P.C.B. L Ass'y) by releasing the self-interlocking pins.

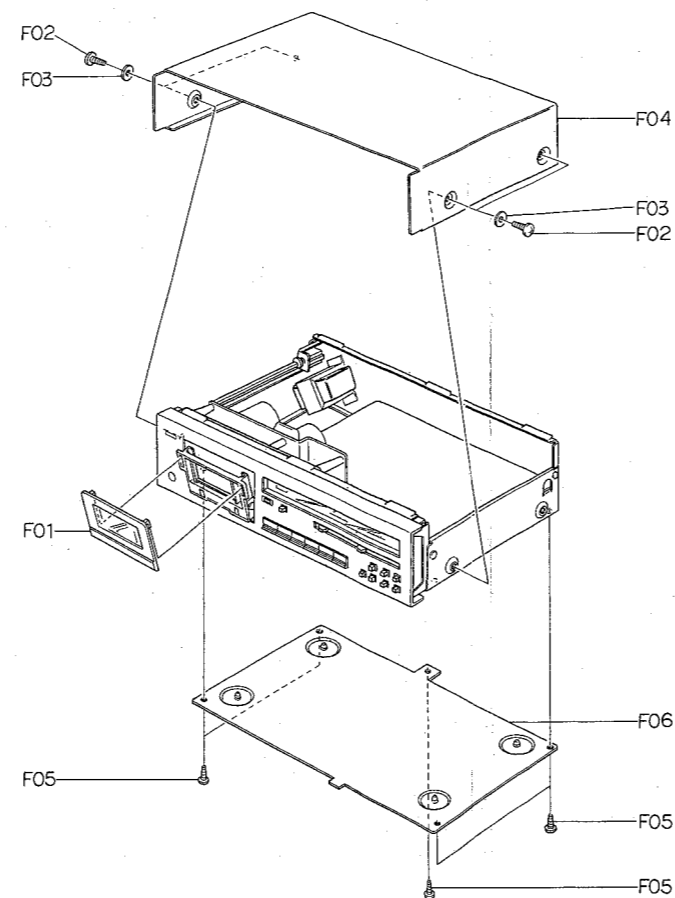

Fig. 3.1

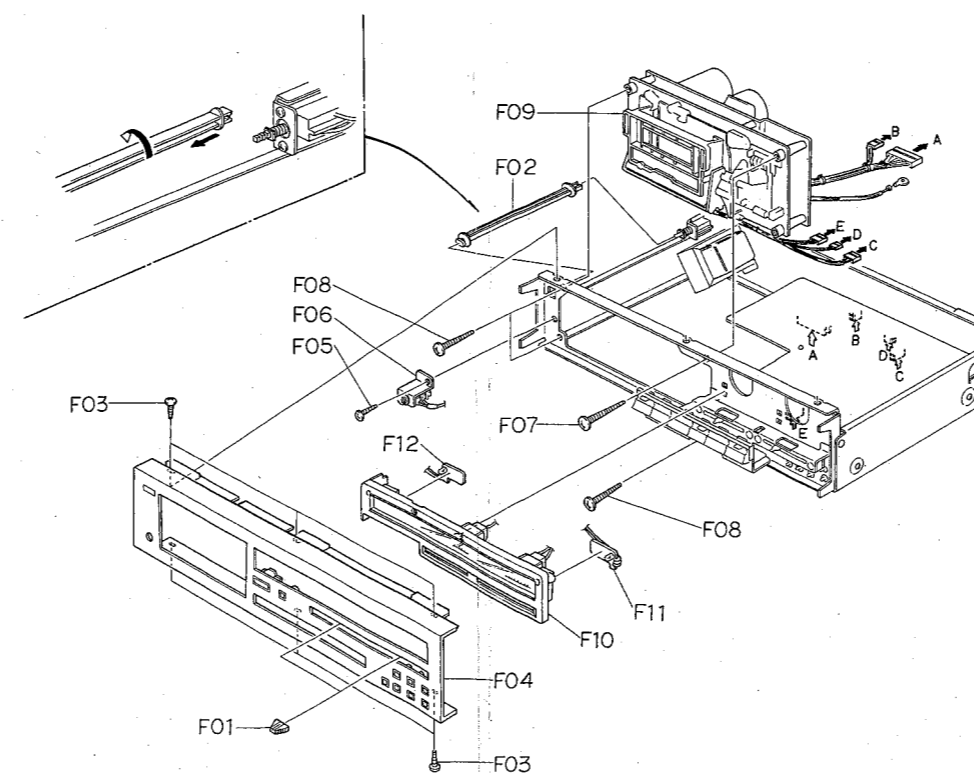

Fig. 3.2

3.9. Main P.C.B. Ass'y

Refer to Fig. 3.3.

- (1) Refer to Fig. 3.2. Remove Front Panel Ass'y referring to item 3.4.
- (2) Remove 5 connectors and the wires connected by wrapping from the F05 (Main P.C.B. Ass'y).
- (3) Remove F01, F02, F03, F04 and the Record Switch Linkage from the Wire Holder assembled with Record Switch, then disassemble F05 (Main P.C.B. Ass'y).

3.10. Control Switch Holder Ass'y

Refer to Fig. 3.3.

- (1) Refer to Fig. 3.2. Remove Meter Ass'y referring to item 3.7.
- (2) Remove F06, then disassemble F07 (Control Switch Holder Ass'y).

3.11. Switch P.C.B. Ass'y

Refer to Fig. 3.3.

- (1) Refer to Fig. 3.2. Remove Front Panel Ass'y referring to item 3.4.
- (2) Remove F08, then disassemble F09 (Switch P.C.B. Ass'y).

3.12. Volume P.C.B. Ass'y and Control Switch P.C.B. Ass'y

Refer to Fig. 3.3.

- (1) Remove Control Switch Holder Ass'y referring to item 3.10.
- (2) Remove F10, then disassemble F11 (Volume P.C.B. Ass'y).
- (3) Remove F12, then disassemble F13 (Control Button Spring).
- (4) Remove F14 (Control Button Shaft), then disassemble F15 (Control Buttons).
- (5) Remove F16, then disassemble F17 (Control Switch P.C.B. Ass'y).

3.13. Rear Panel Ass'y, Power Transformer and Power Switch

Refer to Fig. 3.4.

- (1) Refer to Fig. 3.1. Remove Top Cover Ass'y and Bottom Cover Ass'y referring to items 3.2 and 3.3.
- (2) Remove F01, F02 and F03, then disassemble F04 (Rear Panel Ass'y).
- (3) Remove F05 and F06, then disassemble F07 (Power Transformer).
- (4) Remove Power Switch Joint Bar by releasing the self-interlocking pin of the Power Switch Joint Bar from Power Switch and F08, then disassemble F09 (Power Switch Holder Ass'y).
- (5) Remove F10, then disassemble F11 (Power Switch).

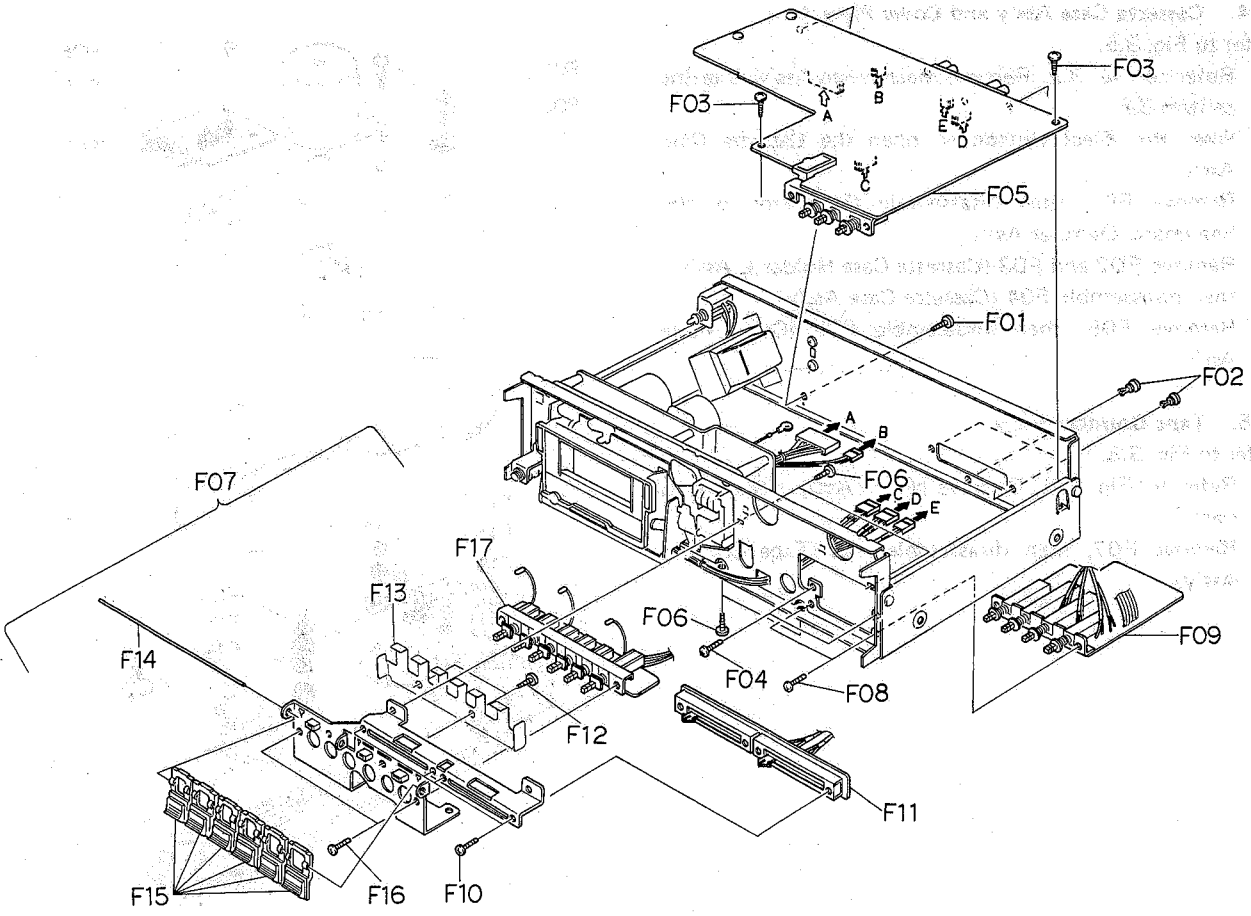

Fig. 3.3

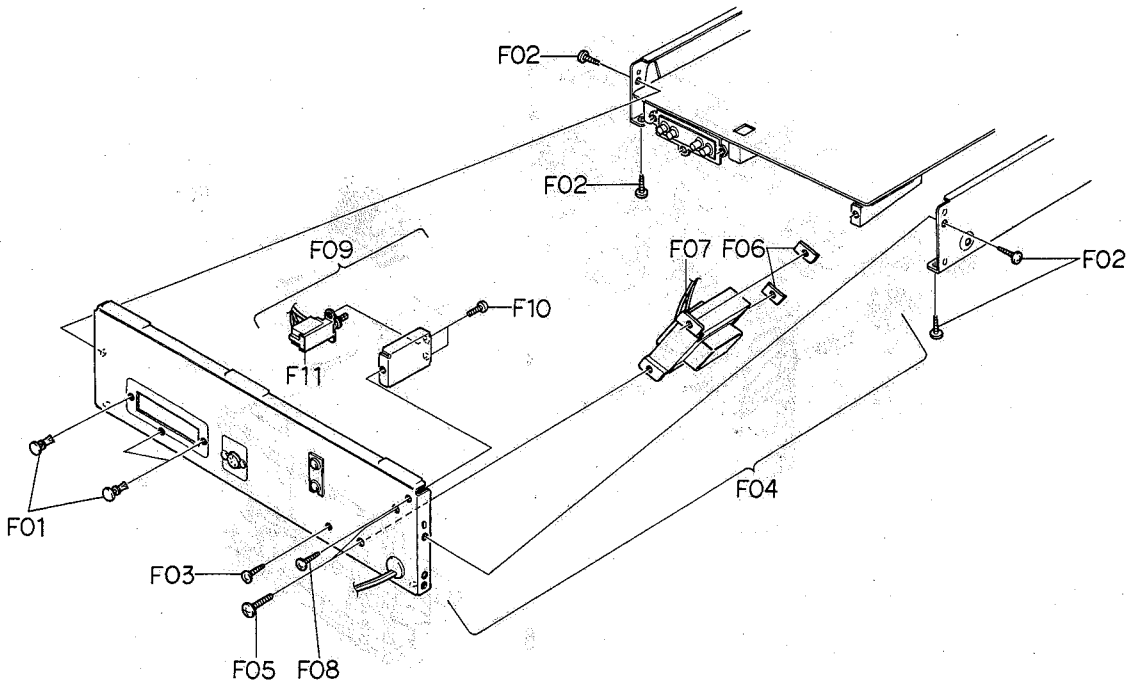

Fig. 3.4

3.14. Cassette Case Ass'y and Cover Plate Ass'y

Refer to Fig. 3.5.

- (1) Refer to Fig. 3.2. Remove Mechanism Ass'y referring to item 3.6.
- (2) Press the Eject Button to open the Cassette Case Ass'y.
- (3) Remove F01, then disassemble the piston of the Pneumatic Damper Ass'y.
- (4) Remove F02 and F03 (Cassette Case Holder L Ass'y), then disassemble F04 (Cassette Case Ass'y).
- (5) Remove F05, then disassemble F06 (Cover Plate Ass'y).

3.15. Tape Counter Ass'y

Refer to Fig. 3.5.

- (1) Refer to Fig. 3.2. Remove Meter Ass'y referring to item 3.7.
- (2) Remove F07, then disassemble F08 (Tape Counter Ass'y).

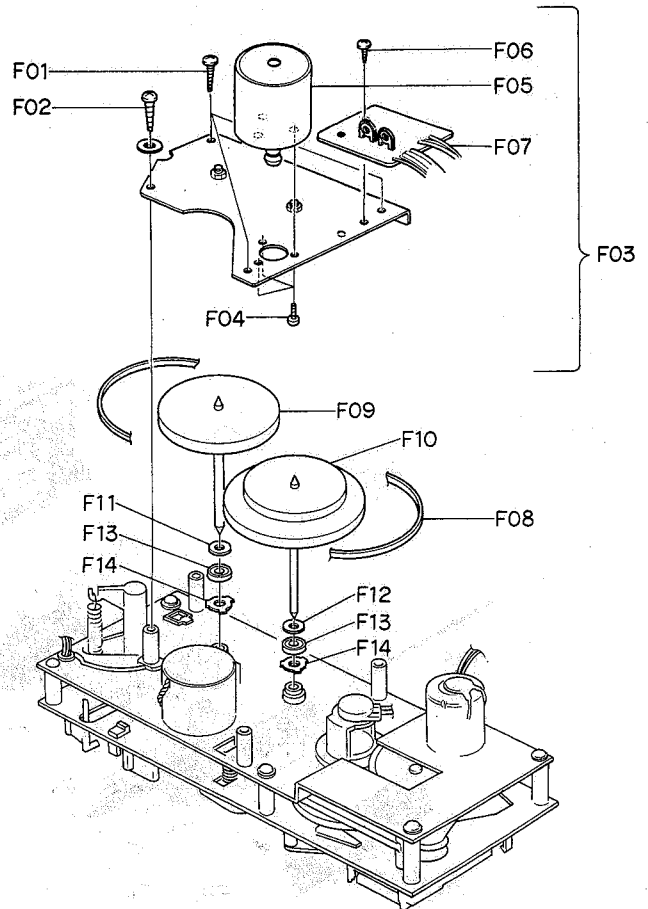

Fig. 3.6

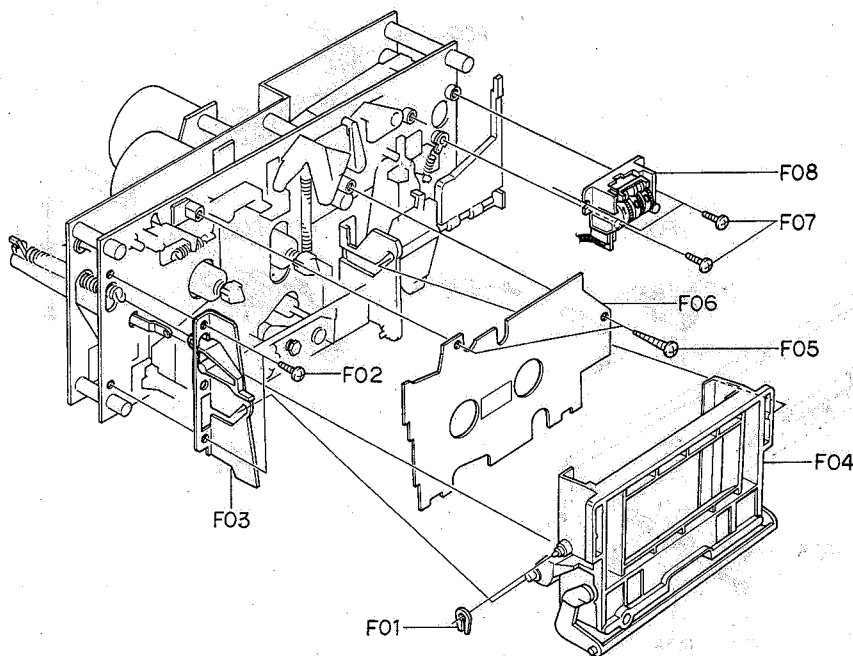

Fig. 3.5

3.16. Capstan Motor Ass'y and Flywheel Ass'y

Refer to Fig. 3.6.

- (1) Refer to Fig. 3.2. Remove Mechanism Ass'y referring to item 3.6.
- (2) Remove F01 and F02, then disassemble F03 (Flywheel Holder Ass'y) and F08 (Capstan Belt).
- (3) Remove F04, then disassemble F05 (Capstan Motor Ass'y).
- (4) Remove F06, then disassemble F07 (Control P.C.B. Ass'y).
- (5) Remove F09 (Supply Flywheel Ass'y), then disassemble F10 (Take-up Flywheel Ass'y).
- (6) After removing both Flywheel Assemblies, disassemble F11 (Thrust Washer 3 mm), F12 (Thrust Washer 2.6 mm), F13 (Flange Thrust Caps) and F14 (Thrust Springs).

3.17. Sub Mechanism Chassis Ass'y

Refer to Fig. 3.7.

- (1) Refer to Fig. 3.6. Remove Flywheel Assemblies referring to item 3.16.
- (2) Remove F01 and F02, then disassemble F03 (Sub Mechanism Chassis Ass'y).

3.18. Control Motor Ass'y and Reel Motor Ass'y

Refer to Fig. 3.7.

- (1) Remove Sub Mechanism Chassis Ass'y referring to item 3.17.
- (2) Remove F04, then disassemble F05 (Control Motor Ass'y).
- (3) Remove F06, then disassemble F07 (Reel Motor Ass'y).

3.19. Cam Control Volume

Refer to Fig. 3.7.

- (1) Remove Sub Mechanism Chassis Ass'y referring to item 3.17.
- (2) Remove F08, then disassemble F09 (Volume Coupler).
- (3) Remove F10, then disassemble F11 (Cam Control Volume).

3.20. Reel Hub Ass'y and Idler Ass'y

Refer to Fig. 3.7.

- (1) Remove Sub Mechanism Chassis Ass'y referring to item 3.17.
- (2) Remove F12 (Reel Hub Heads), then disassemble F13 (Reel Hub B Assemblies), F14 (Reel Hub Take-up Ass'y), F15 (Reel Hub Supply Ass'y), F16 (Back Tension Ass'y) and F17 (Back Tension Spring).
- (3) Remove F18, then disassemble F19 (Idler Ass'y).

3.21. Cam Drive Gear and Control Cam

Refer to Fig. 3.7.

- (1) Remove Sub Mechanism Chassis Ass'y referring to item 3.17.
- (2) Remove F20, then disassemble F21 (Cam Drive Gear).
- (3) Remove F22, then disassemble F23 (Counter-Load Arm Ass'y).
- (4) Remove F24, then disassemble F25 (Control Cam).

3.22. Head Mount Base Ass'y

Refer to Fig. 3.8.

- (1) Refer to Fig. 3.5. Remove Cassette Case Ass'y referring to item 3.14.
- (2) Remove F01, then disassemble F02 (Head Mount Base Ass'y).

3.23. Pressure Roller Ass'y and Erase Head

Refer to Fig. 3.8.

- (1) Remove Head Mount Base Ass'y referring to item 3.22.
- (2) Remove F03 and a washer, then disassemble F04 (Supply Pressure Roller Ass'y).
- (3) Remove F05, then disassemble F06 (Erase Head).
- (4) Remove F07 and a washer, then disassemble F08 (Take-up Pressure Roller Ass'y).

3.24. Playback Head Ass'y and Record Head Ass'y

Refer to Fig. 3.8.

- (1) Remove Head Mount Base Ass'y referring to item 3.22.
- (2) Turn F09 by 90° by pushing it, then disassemble F10 (Playback Head Ass'y).
- (3) Turn F11 by 90° by pushing it, then disassemble F12 (Record Head Ass'y).

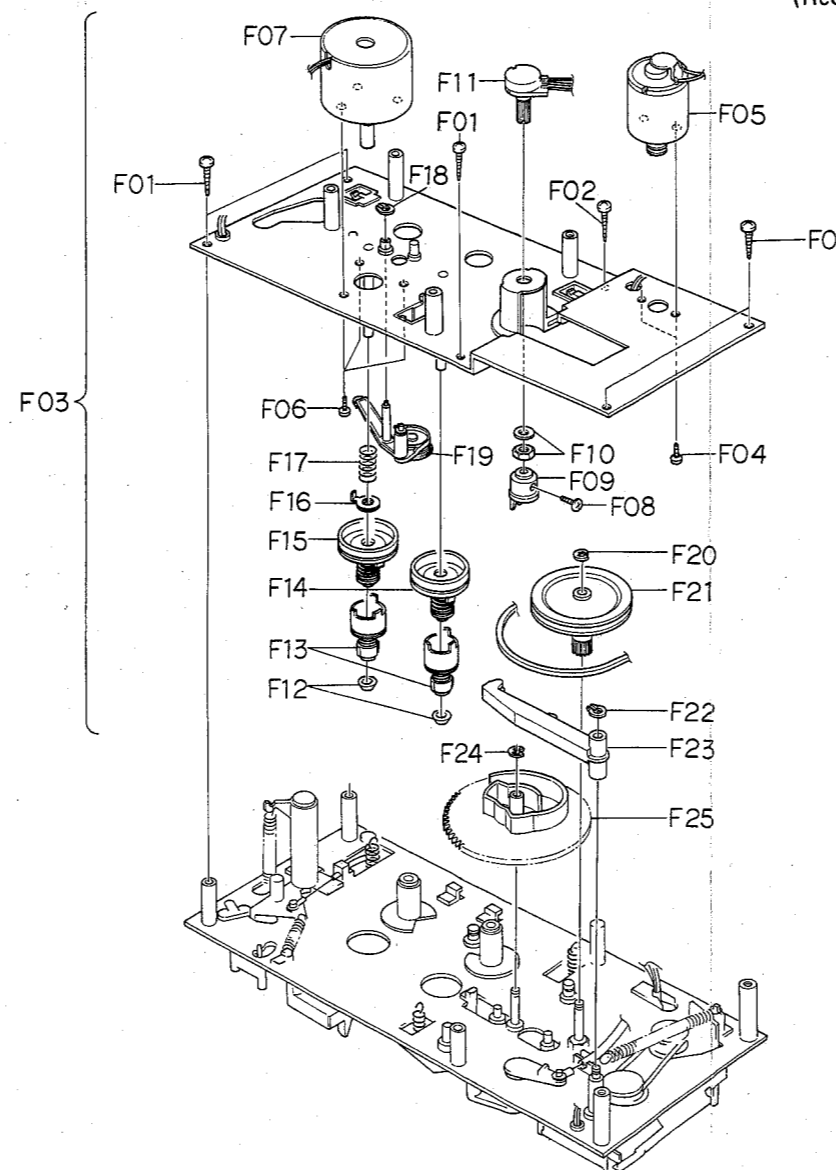

Fig. 3.7

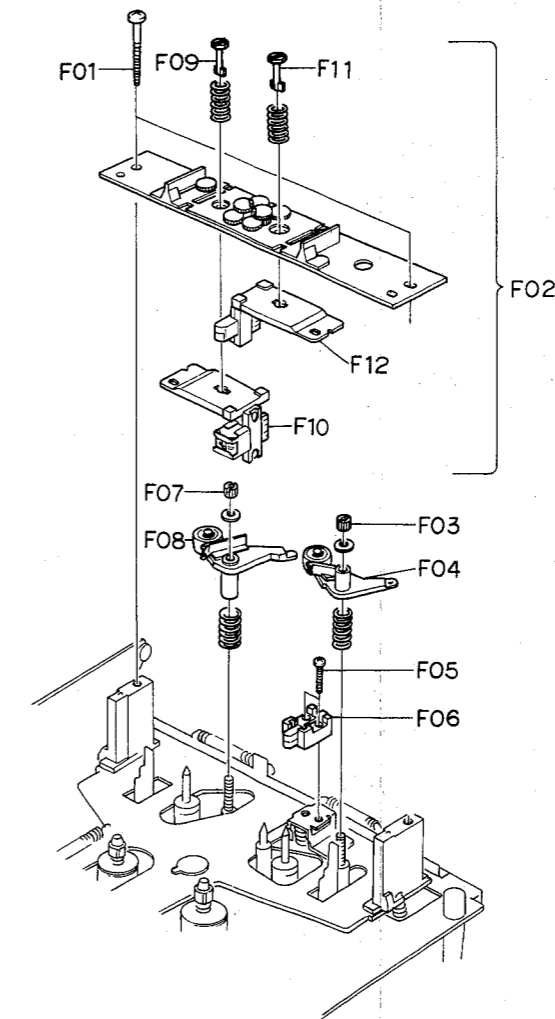

Fig. 3.8

4. MEASUREMENT INSTRUMENTS

- (1) Audio Generator (20 Hz – 200 kHz)
- (2) AC Millivolt Meter (with dB measures)
- (3) Oscilloscope (DC – 5 MHz)
- (4) Distortion Meter
- (5) Speed & WoW/Flutter Meter
- (6) Frequency Counter (DC – 1 MHz)
- (7) Ohm Meter
- (8) DC Volt Meter
- (9) AC Volt Meter
- (10) Torque Gauge (DA09013A)
- (11) 15 kHz Azimuth Tape (DA09004A)
- (12) 3 kHz Speed & Wow/Flutter Tape (DA09006A)
- (13) 1 kHz Track Alignment Tape (DA09007A)
- (14) 400 Hz Level Tape (DA09005A)
- (15) 20 kHz PB Frequency Response Tape (DA09001A)
- (16) 15 kHz PB Frequency Response Tape (DA09002A)
- (17) 10 kHz PB Frequency Response Tape (DA09003A)
- (18) Reference EXII Tape (DA09021A)
- (19) Reference SX Tape (DA09025A)
- (20) Reference ZX Tape (DA09037A)
- (21) Tilt Check Gauge M-9039 (DA09039A)
- (22) EH Tilt Check Gauge M-9040 (DA09040A)
- (23) EH Stroke Check Gauge M-9042 (DA09042A)
- (24) EH Stroke Check Gauge M-9051 (DA09051A)
- (25) Stroke Check Gauge M-9047 (DA09047A)
- (26) Record Head Mounting Gauge M-9048 (DA09048A)
- (27) Audio Analyzer T-100
(including Distortion, Wow/Flutter, Speed, Oscillator and dB meter)

Notes: 1. (10) – (27) are the products of Nakamichi Corporation.
 2. EH Stroke Check Gauge M-9042 (DA09042A) should be used for the Models from serial Nos. A30601001 to A30604798, and EH Stroke Check Gauge M-9051 (DA09051A) is for the Models bearing serial Nos. A30604799 and greater.

5. MECHANICAL ADJUSTMENTS

5.1. Mechanism Control Cam Adjustment

Before Adjustment, disassemble the Front Panel Ass'y then remove the Cover Plate Ass'y, referring to items 3.4 and 3.14.

(1) Offset Adjustment of Control Motor Driver

- (a) Refer to Figs. 5.1 and 5.2.
Adjust VR602 and VR603 on the Control P.C.B. to locate approximately at the middle of the variable range. Then turn ON the Power Switch.
VR602 (for Cam position stop)
VR603 (for Cam position play)
- (b) Press the Stop Switch to set the N-481 in stop mode. Adjust VR602 (for stop) so that the "S" mark on the Cam corresponds to the pointer on the mechanism chassis.
- (c) Press the Play Switch to set the N-481 in playback mode. (Cam will rotate, and the position marked with "PY" comes to the pointer.) Adjust VR603 (for play) so that the "PY" mark on the Cam corresponds to the pointer.
- (d) Repeat above (b) and (c) 2 – 3 times so that the "S" and "PY" marks on the Cam correspond to the pointer accurately in stop and playback modes respectively. (This adjustment is required because the position adjusted by one volume will be slightly changed when the other volume is adjusted.)
- (e) Set the N-481 in FF, pause, or record mode by pressing each switch and check to insure that the pointer is in a range of "F", "PS", or "R" mark respectively.
- (f) If out of the range, precise adjustment for each position according to "(2) Offset Fine Adjustment of Control Motor Driver" will be required.

(2) Offset Fine Adjustment of Control Motor Driver

Adjust only if a satisfactory result is not obtained in "(1) Offset Adjustment of Control Motor Driver". This adjustment is made by changing the value of the fixed resistors on the Main P.C.B.

Note: The value of voltage is typical value.

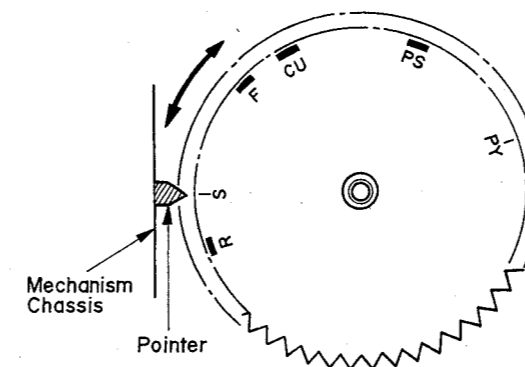

Fig. 5.1

(a) Observation Point of Reference Voltage

Observe the each voltage at the sliding contact of the Cam Control Volume VR601 (10 kΩ) in stop, fast (FF or REW), pause, record and playback modes.

Note: When Record and Play Switches are pressed to set N-481 in record mode, the Cam is first set to the record position in a short period of time then stays at the play position.

Therefore to keep the Cam at the record position, following procedure is required: Short the both leads of capacitor C406 (2.2 μF) on the Main P.C.B. with a jumper wire, then press the Record and Play Switches.

(b) Reference Voltage

Reference voltage at the sliding contact of VR601 (Cam Control Volume) in each mode is as follows:

Mode	Reference Voltage (Typical Value)
Record	16 V $\left\{ \begin{array}{l} +0.4 \text{ V} \\ -0.2 \text{ V} \end{array} \right.$
Stop	15 V $\left\{ \begin{array}{l} \\ \end{array} \right.$
Fast (FF/REW)	13.5 V $\left\{ \begin{array}{l} \\ 1.5 \text{ V} \pm 0.25 \text{ V} \end{array} \right.$
Pause	10 V $\left\{ \begin{array}{l} \\ \end{array} \right.$
Play	7.5 V $\left\{ \begin{array}{l} \\ 2.5 \text{ V} \pm 0.4 \text{ V} \end{array} \right.$

(c) Resistors for Adjustment

Mode	Ref. No.	Typical Value
Stop	R415, R416	9.1 kΩ(F), 15 kΩ(F)
Fast (FF/REW)	R414	56 kΩ (F)
Pause	R454	680 kΩ
Play	R453	120 kΩ
Record	R419	150 kΩ

(d) Adjustment Procedures

- 1) Press the Stop Switch to set the N-481 in stop mode. Adjust the value of R415 and R416 to obtain 15 V (±0.6 V) at the sliding contact of VR601.

Note: When R415 and R416 are adjusted, the re-

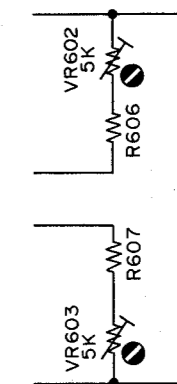

Fig. 5.2

reference voltage in Fast (FF or REW) mode is changed. Therefore, re-check of the reference voltage in Fast (FF or REW) mode is required. If the reference voltage is out of the range, re-adjustment of R414 according to next step 2) is necessary.

- 2) Set the N-481 in FF mode, then adjust the value of R414 so that the voltage of VR601 will become lower by 1.5 V (± 0.25 V) than in stop mode.

- 3) Press the Pause Switch to set the N-481 in pause mode.

Adjust the value of R454 to obtain 10 V ($+0.4$, -0.15 V) at the sliding contact of VR601.

- 4) Set the N-481 in playback mode, then adjust the value of R453 so that the voltage of VR601 will become lower by 2.5 V (± 0.4 V) than in pause mode.

- 5) Short the both leads of capacitor C406 with a jumper wire.

Set the N-481 in record mode, then adjust the value of R419 so that the voltage of VR601 will become higher by 1 V ($+0.4$, -0.2 V) than in stop mode.

Note: Remove the short of C406 after completion of adjustment.

(3) Cam Timing Adjustment

- (a) Remove the wires from the Control Motor terminals to set the motor open.

- (b) Without loading a cassette tape and with pressing the record protecting switch with your finger tip, press the Record and Play Switches to set the N-481 in record mode.

- (c) Turn the Cam and bring the "PY" mark toward the pointer by hand.

Reel Motor will rotate before the "PY" mark reaches the pointer.

Adjust the value of R436 so that the voltage at the sliding contact of VR601 becomes 9.7 V (± 0.3 V) when Reel Motor starts rotation.

- (d) Observe the mute signal at the Q416 collector.

Turn the Cam referring to above step (c) and check to insure that the voltage at the sliding contact of VR601 is 9.5 V (± 0.3 V) when mute is released (mute signal changes from H to L).

(This voltage is determined by the adjustment of R436 in above step (c).)

- (e) Observe the (Play + Pause)—Position signal at the Q411 collector.

Turn the Cam referring to above step (c) and adjust the value of R432 to obtain 11.2 V (± 0.4 V) at the sliding contact of VR601 when (Play + Pause)—Position signal changes from L to H (bias oscillation will begin).

- (f) Upon completion of above adjustment, re-connect wires to the motor terminals.

5.2. Tape Speed Adjustment

- (1) Remove the Top Cover.
- (2) Connect a Frequency Counter to the Output Jack.
- (3) Load a 3 kHz Speed Wow/Flutter Tape (DA09006A) and play it back.
- (4) Referring to Fig. 5.3, adjust the Tape Speed Adjustment Volume (VR501) incorporated in the Capstan Motor to obtain 3,000 Hz on the Frequency Counter.

CCW: Motor drives slowly.

CW: Motor drives fast.

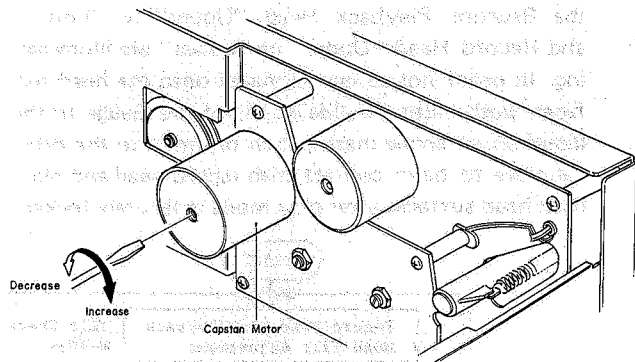

Fig. 5.3

5.3. Record Head and Playback Head Tilt Adjustment

Note: On items 5.3 – 5.8, please refer to Fig. 5.4 flow chart.

Refer to Figs. 5.5 and 5.6.

- (1) Load a Tilt Check Gauge M-9039 (DA09039A) in the N-481.
- (2) Clip the grounding terminal of the Tilt Check Gauge with one end of the cord with clip, and the other end to the chassis of the N-481.
- (3) Remove both of the Height Gears.
- (4) Set the N-481 in play mode. Check to insure whether the Beacons Playback Head "Upper" or "Lower" and Record Head "Upper" or "Lower" are illuminating. In order not to give damages onto the head surfaces, push both of slide knobs of the Gauge to the direction of arrow marks, then return it to the original place to be in contact with record head and playback head surfaces after play mode is securely locked.
- (5) Check to insure freedom from contact between the Gauge and pad lifter.
- (6) Beacon Playback Head "Lower" will light on when height adjustment screw (P) turned clockwise but Playback Head "Upper" when counterclockwise. Adjust so that both "Upper" and "Lower" will light on even when you move the slide knob to the direction of an arrow mark and then return it to the original place.
- (7) Same procedures will apply to the Beacons Record Head "Upper" and "Lower", except for the height adjustment screw (R).
- (8) Set the N-481 in stop mode and fit both of the serrated height gears. Then set the N-481 again in play mode and insure all of the 4 Beacons are illuminating. If not, (3) through (7) will have to be repeated till satisfactory results are obtained.

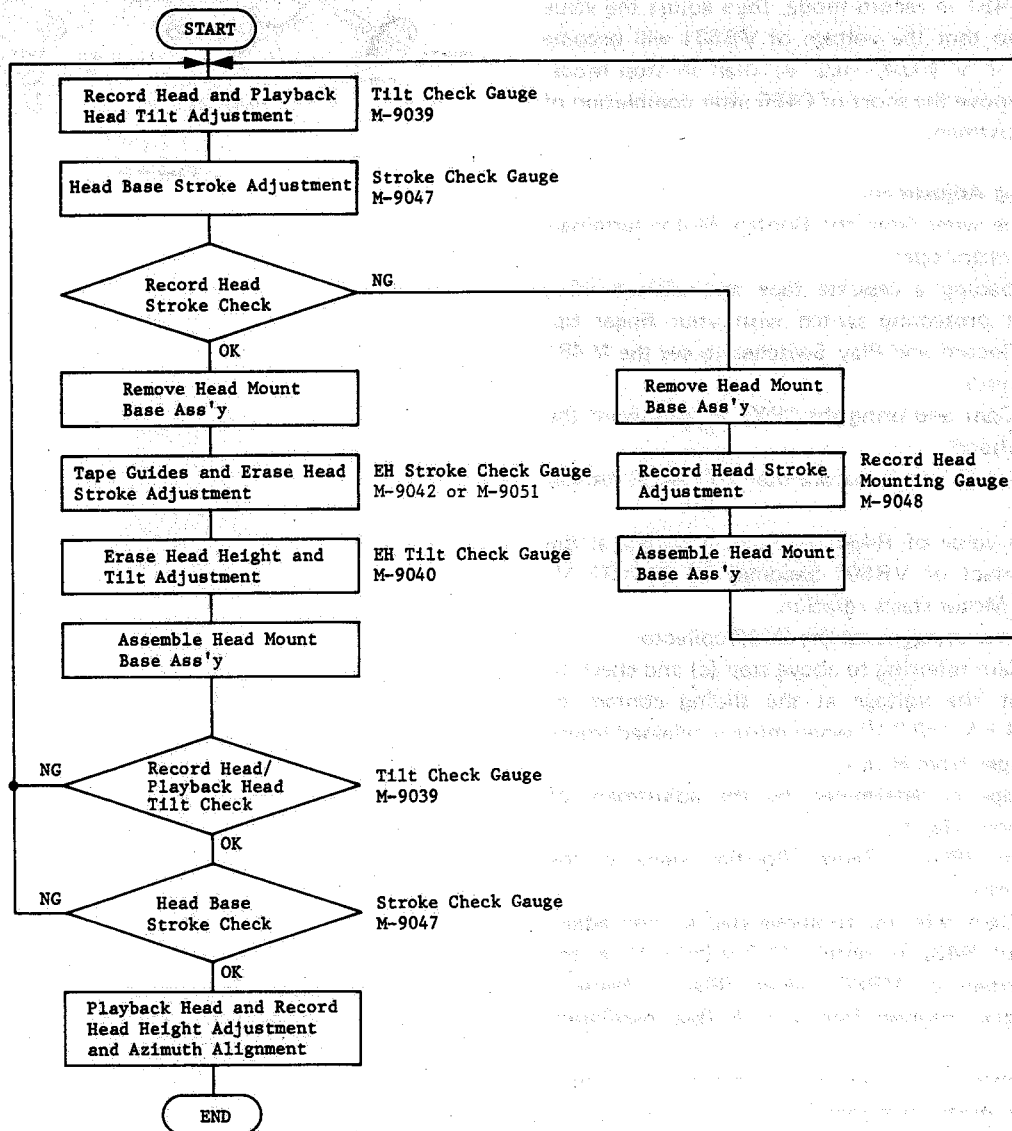

Fig. 5.4

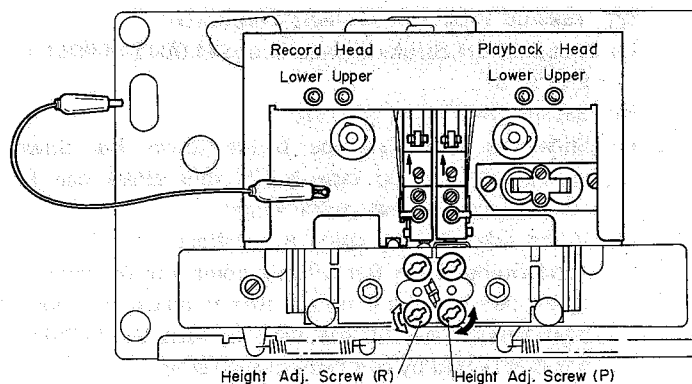

Fig. 5.5

5.4. Head Base Stroke Adjustment

Note: Before you conduct this adjustment, adjust with a "Tilt Check Gauge" to insure freedom from tilt on the playback head and record head.

Refer to Fig. 5.7.

- (1) Load a Stroke Check Gauge M-9047 (DA09047A) in the N-481.
- (2) Move Record Head Indicator and Playback Head Indicator to the direction of arrow mark "A" with your finger tip and then set the N-481 in play mode. Then slowly release the Indicators and insure whether each of the Indicators is in contact with record and playback heads.
- (3) Check to insure whether the "P" pointer on the Play

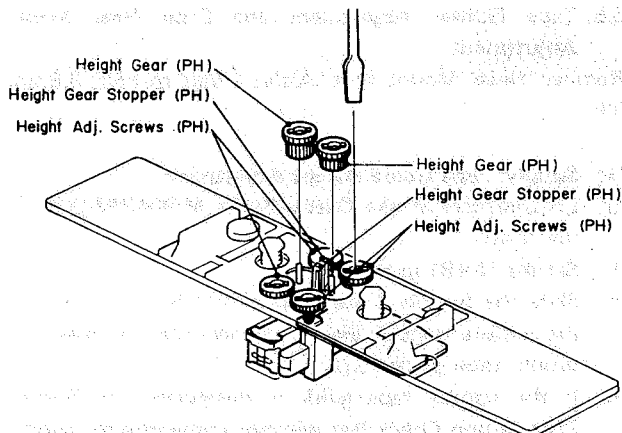

Fig. 5.6

back Head Indicator locates between the 2 lines on the Indicator Plate.

- (4) If the playback head stroke is noted to be misaligned, adjustment can be made by moving the stroke adjuster assembled in the head base assembly (either forwardly or backwardly).
- (5) Check to insure whether the "P" pointer on the Playback Head Indicator locates between the 2 lines on the Record Head Indicator, thus check can be made on record head stroke.
- (6) If the record head stroke is noted to be misaligned, adjustment can be made with a Record Head Mounting Gauge M-9048 (DA09048A).

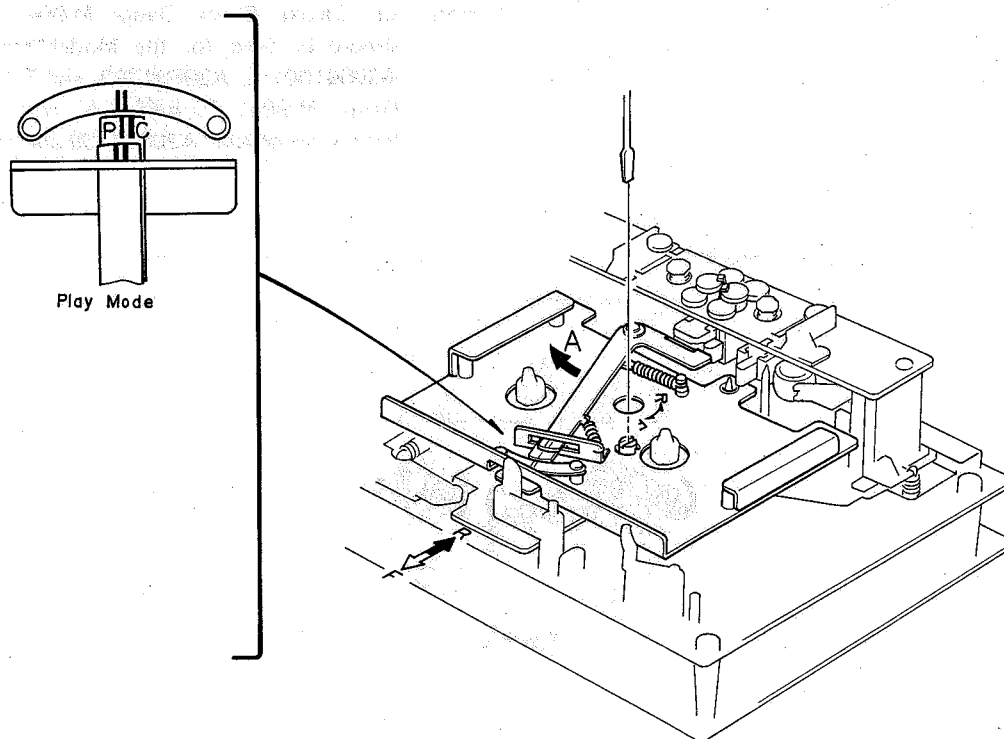

Fig. 5.7

5.5. Tape Guides Adjustment and Erase Head Stroke Adjustment

Remove Head Mount Base Ass'y. Refer to Figs. 5.8 and 5.9.

(1) Supply Tape Guide Height Adjustment

- Load an EH Stroke Check Gauge M-9042/M-9051 in the N-481.
- Set the N-481 in play mode.
- Slide the Supply Tape Guide Check Bar down against the supply tape guide, thus check can be made on supply tape guide height.
- If the supply tape guide is misaligned, the Supply Tape Guide Check Bar will not come into the supply tape guide. If such is noted, turn to adjust the height adjustment nut A till the Supply Tape Guide Check Bar is accepted by the supply tape guide.
- If the above are insured, set the N-481 in pause mode, then in play mode to see whether adjustments are appropriately made. If not, (b) through (e) will have to be repeated till satisfactory results are obtained.

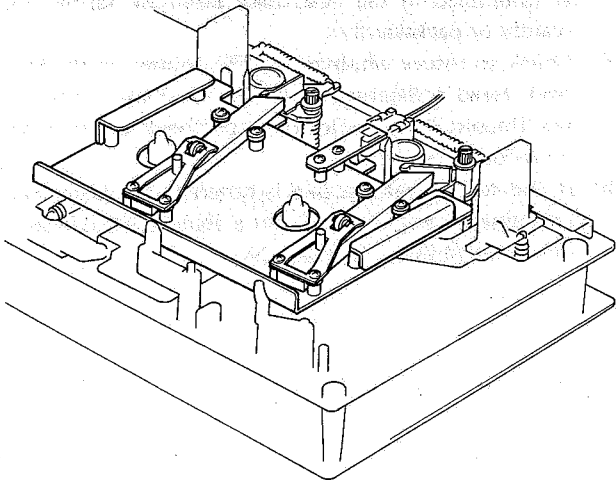

Fig. 5.8

(2) Take-up Tape Guide Height Adjustment

- Load an EH Stroke Check Gauge M-9042/M-9051 in the N-481.
- Set the N-481 in play mode.
- Slide the Take-up Tape Guide Check Bar down against the take-up tape guide, thus check can be made on take-up tape guide height.
- If the take-up tape guide is misaligned, the Take-up Tape Guide Check Bar will not come into the take-up tape guide. If such is noted, turn to adjust the height adjustment nut B till the Take-up Tape Guide Check Bar is accepted by the take-up tape guide.
- If the above are insured, set the N-481 in pause mode, then in play mode to see whether adjustments are appropriately made. If not, (b) through (e) will have to be repeated till satisfactory results are obtained.

(3) Erase Head Stroke Adjustment

- Load an EH Stroke Check Gauge M-9042/M-9051 in the N-481.
- Set the N-481 in play mode, thus check can be made on erase head stroke through the EH Stroke Indicator.
- Check to insure whether the erase head surface is aligned with red line on the EH Stroke Indicator. If not, adjust the erase head stroke by loosening 2 screws that assembled erase head and erase head plate.
- After completion of adjustment, 2 pcs. of screws shall be locked with lock tight paint.

Note: EH Stroke Check Gauge M-9042 (DA09042A) should be used for the Models from serial Nos. A30601001 to A30604798, and EH Stroke Check Gauge M-9051 (DA09051A) is for the Models bearing serial Nos. A30604799 and greater.

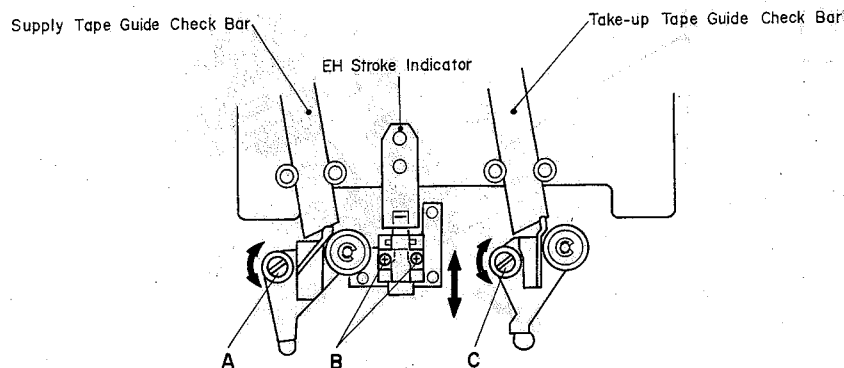

Fig. 5.9

5.6. Erase Head Height and Tilt Adjustment

Refer to Figs. 5.10 and 5.11.

- (1) Remove Head Mount Base Ass'y referring to item 3.22.
- (2) Load an EH Tilt Check Gauge M-9040 (DA09040A) in the N-481.
- (3) Set the N-481 in stop mode.
- (4) Check to insure whether one of the 3 Beacons is illuminating. Look down the mirror as shown by an arrow mark and slowly turn the Screw "Height" counterclockwise (or clockwise) so that the two horizontal lines of the mirror will become superposed on the line (in different color) of the erase head, and check to insure whether Beacon "1" is illuminating.
- (5) Turn Screw "Tilt" counterclockwise (or clockwise) to light on Beacon "2". Excessive turning will cause the Beacon "1" to light off. Adjustments of Screw "Tilt" will therefore be conducted till both of the Beacons "1" and "2" illuminate.

- (6) Turn Screw "Azimuth" counterclockwise (or clockwise) to light on Beacon "3". Excessive turning will cause either Beacon "1" or "2" to light off, and therefore adjust with Screw "Azimuth" until all of the 3 Beacons "1", "2" and "3" illuminate.
- (7) Check to insure whether the horizontal line on the mirror corresponds to that on the erase head. If not, (4) through (7) will have to be repeated till satisfactory results are obtained.
- (8) After completion of adjustment, 3 pcs. of screws shall be locked with lock tight paint.

Note: Before use of this gauge, check to insure freedom from dust or dirt, or overflow in the groove of the erase head surface.

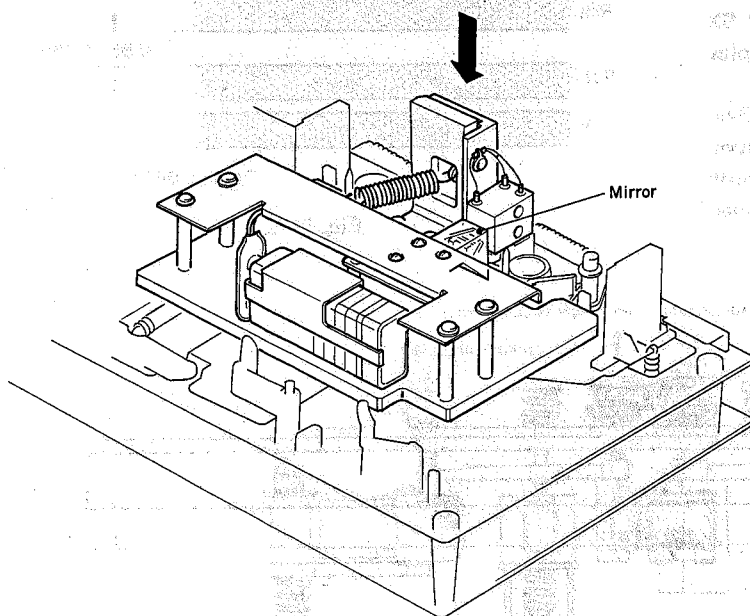

Fig. 5.10

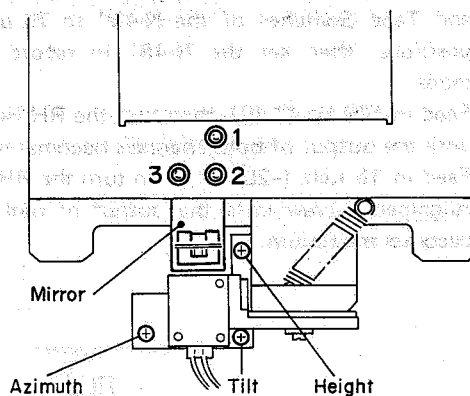

Fig. 5.11

5.7. Playback Head and Record Head Height Adjustment and Azimuth Alignment

Refer to Fig. 5.12.

(1) Playback Head Height Adjustment and Azimuth Alignment

- (a) Connect a VTVM to the Output Jacks.
- (b) Load a 1 kHz Track Alignment Tape (DA09007A), then set the N-481 in play mode.
- (c) Turn the PH Height Gear until the output of both channels becomes minimum.
- (d) Load a 15 kHz Azimuth Tape (DA09004A), then set the N-481 in play mode.
- (e) Turn the PH Azimuth Alignment Screw until the output of both channels becomes maximum.
- (f) Repeat (b) through (e) 1 – 2 times.

(2) Record Head Height Adjustment and Azimuth Alignment

- (a) Connect a VTVM to the Output Jacks.
- (b) Load a Reference SX Tape (DA09025A). Set the Eq. and Tape Switches of the N-481 to 70 μ s and SX positions, then set the N-481 in record and play mode.
- (c) Feed in 400 Hz (0 dB), then turn the RH Height Gear until the output of both channels becomes maximum.
- (d) Feed in 15 kHz (-20 dB), then turn the RH Azimuth Alignment Screw until the output of both channels becomes maximum.

- (e) Repeat (c) and (d) 1 – 2 times.
- (f) After completion of both adjustment and alignment, feed in 400 Hz (0 dB) and record it to the same portion of both A and B sides of the tape.
- (g) Immerse the recorded tape in a magnetized developing solution. In turn, check to insure that the recording head tracks across the center are separated with a distance of 0.55 to 0.75 mm (typically 0.65 mm) as illustrated in Fig. 5.13.

Note: Liquid for tape magnetized development solution

"MAGNA-SEE, SOUND CRAFT a product of CBS RECORDS a division of Columbia Broadcasting System, Inc., Danbury, Conn. 06810 U.S.A., or equivalent".

After development, clean the tape otherwise pressure rollers and heads will become dirty.

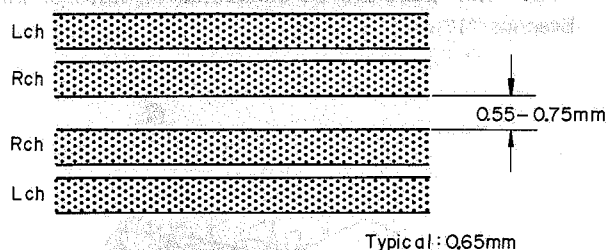

Fig. 5.13

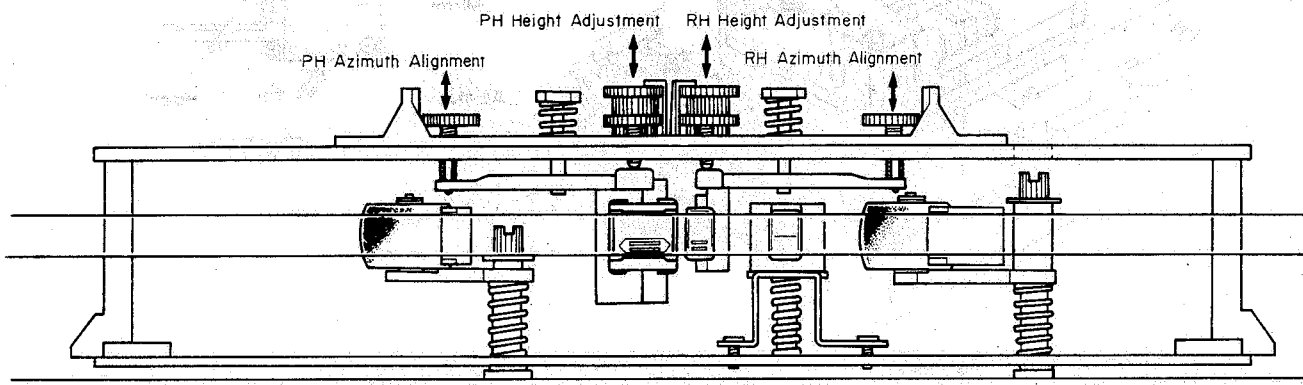

Fig. 5.12

5.8. Record Head Stroke Adjustment

Refer to Figs 5.14 and 5.15.

Note: This adjustment will be required only to insure freedom from misalignment of the record head stroke in the record head stroke check mode.

- (1) Check the accuracy of the record head stroke.
- (2) Remove Head Mount Base Ass'y referring to item 3.22.
- (3) Remove the record head assembly.
- (4) Adjustment of Record Head Mounting Gauge M-9048 (DA09048A)
 - (a) Mount the Block B onto the Mounting Gauge Plate.
 - (b) Loosen the 2 screws fixing the Block A.
 - (c) As shown in the Fig. 5.14, hold the Gauges (3.05 mm and either one of 0.05, 0.15, 0.2, 0.25, 0.3 or 0.35 mm thickness) between the Block A and Block B, fix the Block A with screw, pushing the Block A to the 2 guide pins.
- (5) Remove the Block B from the Mounting Gauge Plate.
- (6) As shown in the Fig. 5.15, mount the R-8L record head assembly onto the Mounting Gauge Plate, then check the location of the R-8L record head surface. (If record head contacts to the Block C, loosen 2 pcs. of screws that assembled record head and R-8L record head assembly, then place the R-8L record head assembly onto the Plate.)
- (7) Remove the R-8L record head assembly from the Mounting Gauge Plate.

- (8) Readjustment of Record Head Mounting Gauge M-9048 (DA09048A)
 - (a) Mount the Block B onto the Mounting Gauge Plate.
 - (b) Loosen the 2 screws fixing the Block A.
 - (c) As shown in the Fig. 5.14, hold the Gauges (3.05 mm and either one of 0.05, 0.15, 0.2, 0.25, 0.3 or 0.35 mm thickness) between the Block A and Block B, fix the Block A with screw, pushing the Block A to the 2 guide pins.

- (9) Remove the Block B from the Mounting Gauge Plate.
- (10) Mount the R-8L record head assembly onto the Mounting Gauge Plate.
- (11) As shown in the Fig. 5.15, loosen the R-8L record head with 2 pcs. of screws onto the record head plate. As the location of the Block A is secured by the item (8) - (c), push the record head to the directions A and B, then tighten 2 pcs. of screws.
- (12) Check to insure freedom from gap between the Block C and record head surface, then tighten the 2 pcs. of screws on the record head plate with lock tight paint.
- (13) Assemble the record head assembly to the head mount base assembly.
- (14) Assemble the head mount base assembly to the mechanism assembly.
- (15) Check the record head stroke.

If the above are inaccurate, items (1) through (15) will have to be repeated till satisfactory results are obtained.

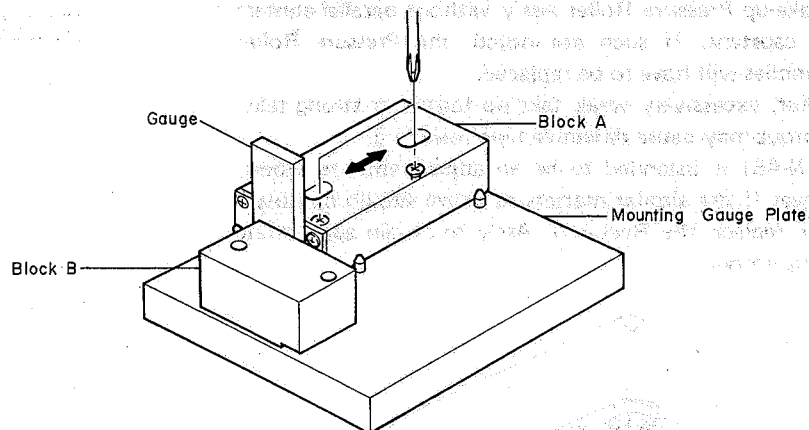
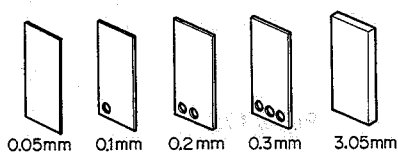

Fig. 5.14

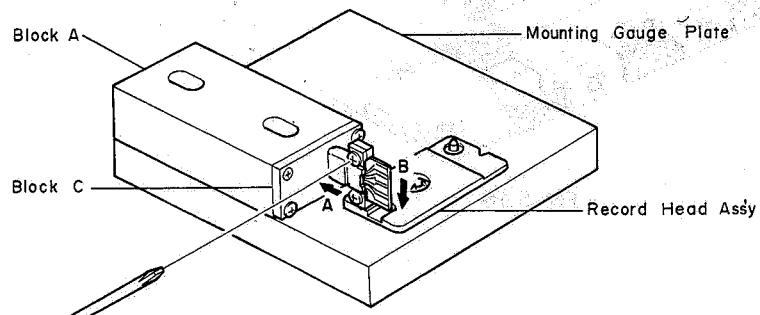

Fig. 5.15

5.9. Tape Travelling Adjustment

The adjustment shall be made with a modified version of the current type EXII C-90 as shown in Fig. 5.16 (error will be made if a current type Tape Travelling Cassette (DA09011A) should be used for this purpose).

While modifying an EXII C-90, the tape guides in the cassette housing shall be kept protected to avoid tilt. Check shall be made in the following procedures:

- (1) An EXII C-90 Tape thus modified shall be loaded onto the N-481.
- (2) Release the back-tension (rotate the Supply Reel and feed out some length of tape) and set the N-481 in play mode.
- (3) In this juncture, check to insure whether the tape is free from waving or slippage from the tape guide.
- (4) When the modified EXII C-90 is played back, check to insure whether the tape is freedom from waving from head surface or at pressure rollers.
- (5) If either of waving or slippage from the tape guide should be noted, adjustments of "5.3. Record Head and Playback Head Tilt Adjustment", "5.4. Head Base Stroke Adjustment", "5.5. Tape Guides Adjustment and Erase Head Stroke Adjustment", "5.6. Erase Head Height and Tilt Adjustment", "5.7. Playback Head and Record Head Height Adjustment and Azimuth Alignment", "5.8. Record Head Stroke Adjustment", etc. will be required.

As a case may be, the said waving or slippage may have been caused from defective supply Pressure Roller Ass'y or Take-up Pressure Roller Ass'y without parallel contact with capstans. If such are noted, the Pressure Roller Assemblies will have to be replaced.

Further, excessively weak take-up torque or strong take-up torque may cause defective tape travelling.

The N-481 is intended to be an adjustment-free Model, however if the similar matters as above should be noted, please replace the Reel Hub Ass'y to obtain appropriate take-up torque.

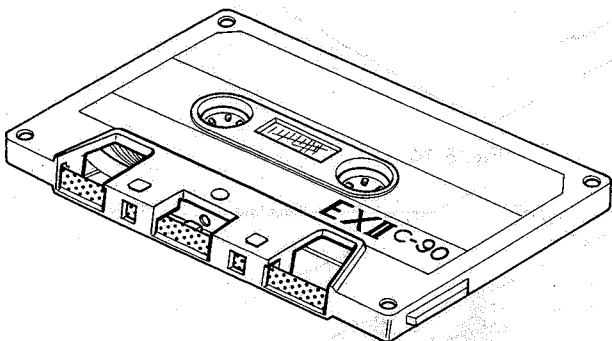

Fig. 5.16

5.10. Record Switch Linkage Adjustment

- (1) Set the N-481 in stop mode.
- (2) Loosen the screw of the Record Spring Holder, and shift the Record Spring Holder in order to remove the looseness of the Linkage Wire as shown in Fig. 5.17.1. Then tighten the screws for fixing the Record Spring Holder. (In this case, the Record Switch should be positioned at play side. If on the record position, it will be defective.)
- (3) Set the N-481 in record and pause mode. Check to insure that the gap between the top of the wire and the Record Spring Holder is approx. 1 mm as shown in Fig. 5.17.2. (Check that the Record Switch is in record position.)
- (4) Upon completion of the above adjustments, apply a quantity of lock tight paint.

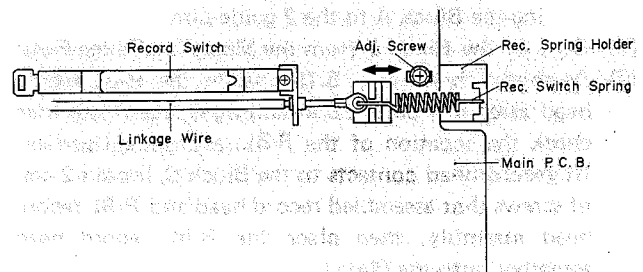

Fig. 5.17.1

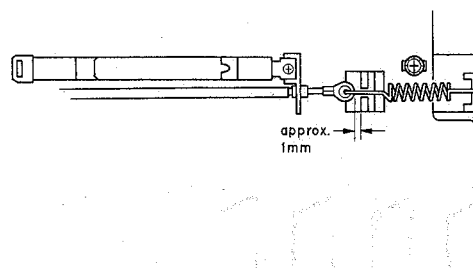

Fig. 5.17.2

5.11. Flywheel Holder Adjustment

(1) Refer to Fig. 5.18.

Tighten the Thrust Screws until the gap between the Flywheel Assemblies and Thrust Screws becomes minimized when both of the Capstan Shafts are moved backwardly and forwardly (the Thrust Springs between the Capstan Flanges and Flywheel Thrust Caps are in a flat state).

Excessive tightening of the Thrust Screws however will give damages on the Flywheel Assemblies, to which careful attention is invited.

- (2) Return the Thrust Screws by 1/2 turn.
- (3) Fixing the Thrust Screws with a screwdriver, lock the Lock Nut.
- (4) Apply a quantity of lock tight paint to the Thrust Screws.

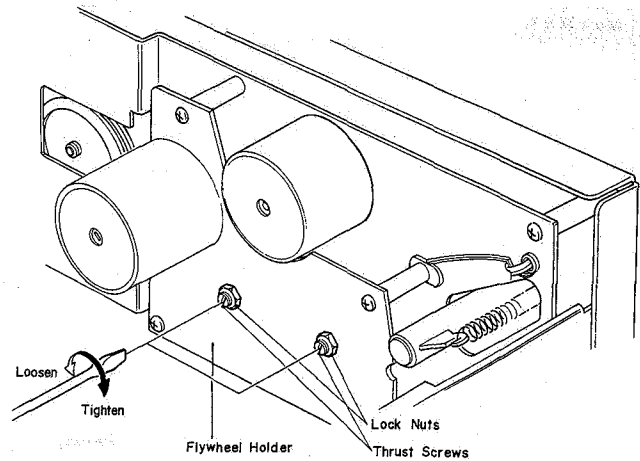

Fig. 5.18

5.12. Eject Wire Adjustment

- (1) Referring to Fig. 5.19.1, insert a 1.5 mm spacer between the Eject Arm and Eject Stopper by turning the Eject Arm in the illustrated direction, then set the N-481 in playback mode.
- (2) With pushing the Eject Arm by hand, loosen the screw and then pull the Eject Wire in the direction of the arrow until it stops as shown in Fig. 5.19.2.
- (3) Tighten the screw, then apply a quantity of lock tight paint.

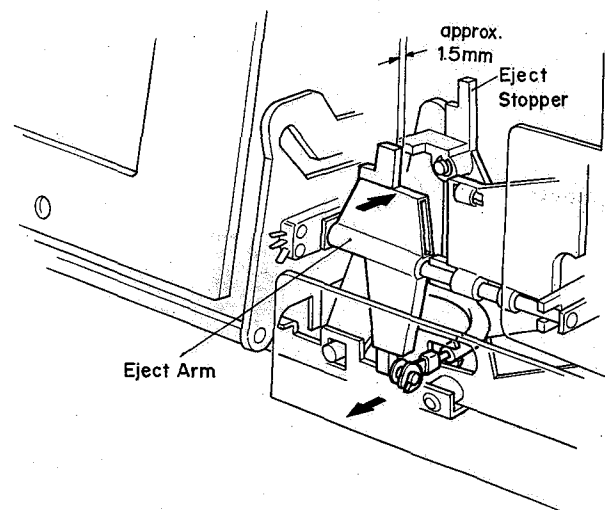

Fig. 5.19.1

5.13. Lubrication

N-481 is a lubrication-free cassette deck except when parts are replaced. Apply the following lubricant for each replaced part:

- (1) LAUNA #100
 - Capstan Shaft
 - Pressure Roller Shaft
 - Thrust Cap
- (2) FLOIL GB-TS-1
 - Reel Hub Shaft
 - Thrust portion on the Capstan Shaft
 FLOIL GB-TS-1, made by Kanto Chemicals Co., Ltd. in Japan.

We suggest you use the above or equivalent type. If unavailable please contact Kanto Chemicals Co., Ltd., 2-7 Kanda Suda-cho Chiyoda-ku, Tokyo 101 Japan.
- (3) Silicon Oil #3000 CST
 - Air Damper Piston

Note: Excessive lubrication may cause defective damper action as the 0.2 ϕ hole at the end of the cylinder may be filled with oil.

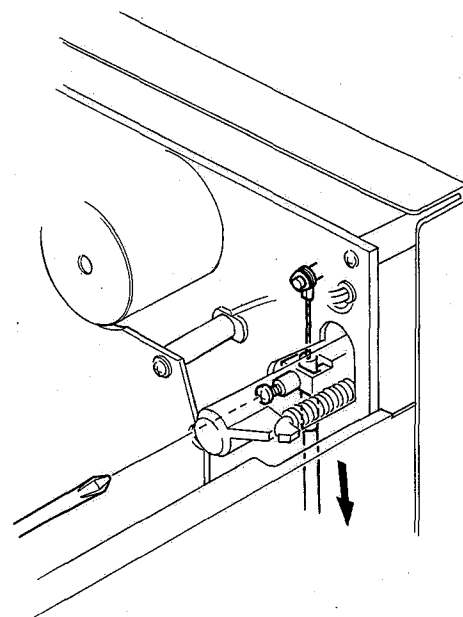

Fig. 5.19.2

6. PARTS LOCATION FOR ELECTRICAL ADJUSTMENT

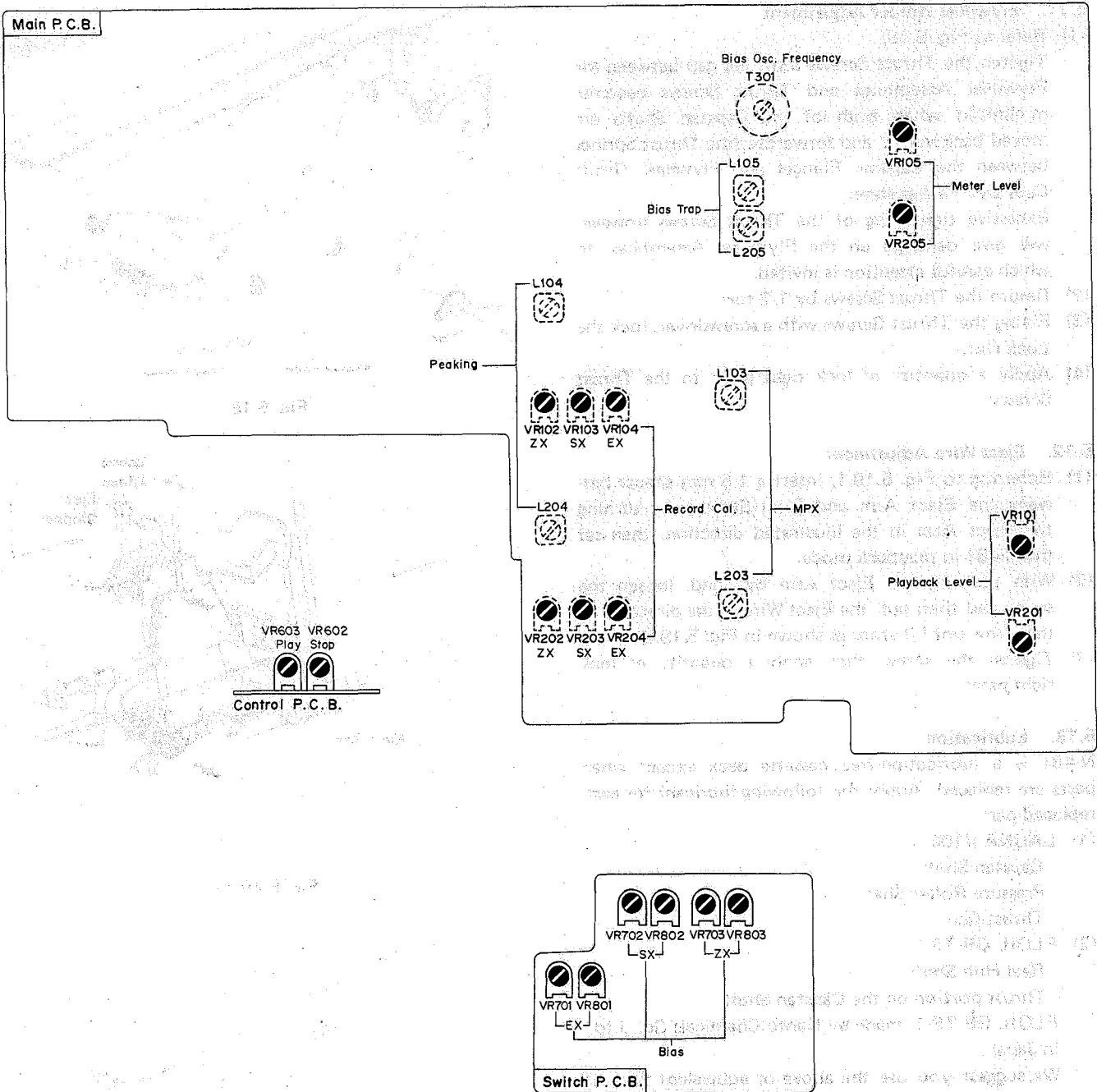

Fig. 6

7. ELECTRICAL ADJUSTMENTS AND MEASUREMENTS

7.1. Adjustment and Measurement Instructions

Note: Electrical adjustment should be performed after mechanical adjustment is completed.

STEP	ITEM	SIGNAL SOURCE	OUTPUT CONNECTION	MODE	ADJUSTMENT	REMARKS
1	Tape Speed	3 kHz Speed and Wow/Flutter Tape (DA09006A)	Frequency Counter to OUTPUT Jacks	Playback Eq. SW – 70 μs	Capstan Motor Governor P.C.B. VR501	Adjust VR501 to obtain 3 kHz ± 0.5%. (VR501 is incorporated in the capstan motor.)
2	Meter Level	400 Hz to INPUT Jacks	VTVM to TP101, TP201 on the Main P.C.B.	Record, Pause	Main P.C.B. VR105, VR205	1. Set the input level controls to maximum. 2. Adjust the oscillator output to obtain 100 mV at TP101 (TP201), then adjust VR105 (VR205) to obtain 0 dB on the level meters.
3	MPX Filter	19 kHz ± 100 Hz to INPUT Jacks	VTVM to OUTPUT Jacks	Record, Pause MPX SW – OUT/IN	Main P.C.B. L103, L203	1. Adjust input level controls to obtain 600 mV on the VTVM. 2. Set the MPX Switch to 1N position, then adjust L103 (L203) to obtain minimum reading on the VTVM (minimum reading will be less than -30 dB).
4	Playback Head Track Alignment	1 kHz Track Alignment Tape (DA09007A)	Same as above	Playback MPX SW – OUT Eq. SW – 70 μs Dolby NR SW – OUT	Playback Head Height Adjustment Screw	Adjust the Playback Head Height Adj. Screw to obtain minimum reading of both L and R channels on the VTVM. See "Playback Head Height Adjustment and Azimuth Alignment" in item 5.7.
5	Playback Head Azimuth Alignment	15 kHz Azimuth Tape (DA09004A)	Same as above	Same as above	Playback Head Azimuth Alignment Screw	Adjust the Playback Head Azimuth Alignment Screw to obtain maximum reading of both L and R channels on the VTVM. See "Playback Head Height Adjustment and Azimuth Alignment" in item 5.7. Note: Repeat steps 4 and 5 one or two times to obtain optimum performance.
6	Playback Level	400 Hz Level Tape (DA09005A)	VTVM to TP101, TP201	Same as above	Main P.C.B. VR101, VR201	Adjust VR101 (VR201) to obtain 100 mV on the VTVM or 0 dB on the level meters.
7	Playback Frequency Response	400 Hz Level Tape (DA09005A) 10 kHz PB Frequency Tape (DA09003A) 15 kHz PB Frequency Tape (DA09002A) 20 kHz PB Frequency Tape (DA09001A)	VTVM to OUTPUT Jacks	Same as above	Main P.C.B. R112, R212	1. Load the 400 Hz level tape and play it back. 2. Load the 10 kHz, 15 kHz and 20 kHz PB Frequency Response Tapes and adjust the playback head azimuth to give maximum levels on the VTVM with each tape. Short R112 (R212) to obtain the following levels against 400 Hz level tape. Refer to Fig. 7.3. 10 kHz (-20 dB) -2 dB to + 2 dB 15 kHz (-20 dB) -2 dB to + 3 dB 20 kHz (-20 dB) -2 dB to + 4 dB 3. Conduct step 5 "Playback Head Azimuth Alignment". 4. If above is not sufficient, refer to "Playback Frequency Response Adjustment" in item 7.2.

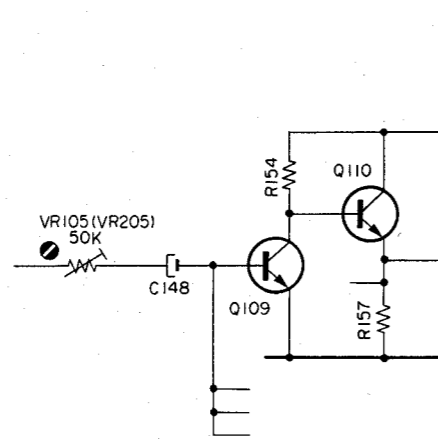

Fig. 7.1
2. Meter Level

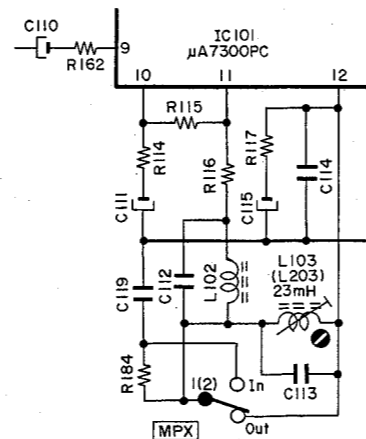

Fig. 7.2
3. MPX Filter

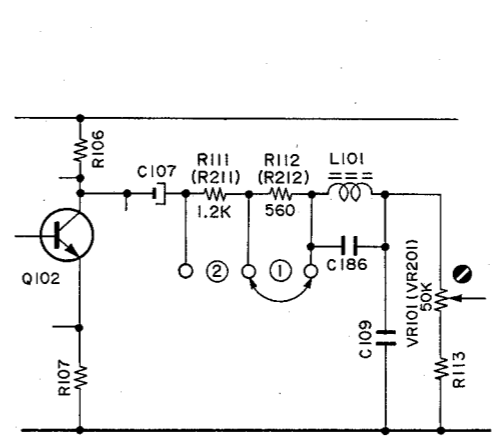

Fig. 7.3
6. Playback Level
7. Playback Frequency Response

STEP	ITEM	SIGNAL SOURCE	OUTPUT CONNECTION	MODE	ADJUSTMENT	REMARKS
8	Bias Oscillation Frequency and Erase Current	External 0.1 Ω Resistor in series to Erase Head	VTVM and Frequency Counter across the 0.1 Ω Resistor	Record, Pause Tape SW — ZX Eq. SW — 70 μ s Dolby NR SW — OUT MPX SW — OUT	Main P.C.B. T301 R310, R311	<ol style="list-style-type: none"> 1. Adjust T301 to obtain 105 kHz on the frequency counter. 2. Check the erase current by the VTVM. Erase current will be in a range of 310 mA to 400 mA (typically approx. 350 mA). If erase current is not sufficient, increase it by shorting R310 or R311. 3. After completion of the erase current adjustment, re-check the bias oscillation frequency.
9	Record Amplifier Equalizer	21 kHz (–20 dB) to INPUT Jacks	VTVM to CN5-1, CN5-3 on the Main P.C.B.	Same as above	Main P.C.B. L104, L204	<ol style="list-style-type: none"> 1. Remove the bias-cut-jumper from the dip side of the Main P.C.B. 2. Adjust L104 (L204) to obtain peak reading at 21 kHz on the VTVM. 3. Re-solder the bias-cut-jumper.
10	Bias Trap	Remove INPUT Signals	Same as above	Same as above	Main P.C.B. L105, L205	Adjust L105 (L205) to obtain maximum reading on the VTVM.
11	Record Head Height Adjustment	400 Hz (0 dB) to INPUT Jacks	VTVM to TP102, TP202	Record, Playback Tape SW — SX Eq. SW — 70 μ s Dolby NR SW — OUT MPX SW — OUT	Record Head Height Adj. Screw	Adjust the Record Head Height Adj. Screw to obtain maximum reading of L and R channels on the VTVM. See "Record Head Height Adjustment and Azimuth Alignment" in item 5.7.
12	Record Head Azimuth Alignment	15 kHz (–20 dB) to INPUT Jacks	Same as above	Same as above	Record Head Azimuth Alignment Screw	Adjust the Record Head Azimuth Alignment Screw to obtain maximum reading of L and R channels on the VTVM. See "Record Head Height Adjustment and Azimuth Alignment" in item 5.7.
13	Record Level Calibration and Recording Bias Current Adjustment	400 Hz (0 dB) and 15 kHz (–20 dB) to INPUT Jacks	VTVM to TP102, TP202 and OUTPUT Jacks Distortion Meter to OUTPUT Jacks	Record, Playback Tape SW — EX/SX/ZX Eq. SW — 120 μ s (EX) 70 μ s (SX/ZX) Dolby NR SW — OUT MPX SW — OUT	(Rec. Level) EX: VR104, VR204 SX: VR103, VR203 ZX: VR102, VR202 (Bias Current) EX: VR701, VR801 SX: VR702, VR802 ZX: VR703, VR803	<ol style="list-style-type: none"> 1. Connect VTVM to TP102 (TP202) on the Main P.C.B. 2. Feed in 400 Hz, then set the input level controls to obtain 0 dB on the level meters. 3. Record signals on the reference EXII tape (DA09021A), reference SX tape (DA09025A), or reference ZX tape (DA09037A), then play it back. 4. Adjust Rec. Cal. VR104 (VR204) (for EXII), VR103 (VR203) (for SX) and VR102 (VR202) (for ZX) to the center their positions. 5. Adjust Bias VR701 (VR801) (for EXII), VR702 (VR802) (for SX) and VR703 (VR803) (for ZX) to obtain maximum readings on the VTVM. 6. Feed in 15 kHz (–20 dB), then adjust Bias VR701 (VR801), VR702 (VR802) and VR703 (VR803) to obtain 3 mV on the VTVM. 7. Feed in 400 Hz (0 dB), then adjust Rec. Cal. VR104 (VR204), VR103 (VR203) and VR102 (VR202) to obtain 30 mV on the VTVM. 8. Repeat 5 through 7 as above two or three times to obtain optimum performance. 9. After completion of above adjustment, check to insure the followings: <ol style="list-style-type: none"> a. Connect the VTVM to Output Jacks. b. Feed in 400 Hz (0 dB), then record signals for each tape. c. Play it back after rewind, then check to insure whether the readings on the VTVM are 600 mV (level meters will indicate 0 dB). d. Feed in 15 kHz (–20 dB), then record signals for each tape. e. Play it back after rewind, then check to insure whether the readings on the VTVM are 60 mV (level meters will indicate –20 dB). f. If above is not sufficient, repeat above steps 1 through 9 until satisfactory results are obtained. 10. Check to insure whether the Total Harmonic Distortion (T.H.D.) is less than 1.0% for EXII and SX tapes, and 0.9% for ZX tape.

STEP	ITEM	SIGNAL SOURCE	OUTPUT CONNECTION	MODE	ADJUSTMENT	REMARKS
14	Overall Frequency Response	400 Hz (0 dB) and 20 Hz to 18 kHz (-20 dB) to INPUT Jacks	VTVM to OUTPUT Jacks	Record, Playback Tape SW - EX/SX/ZX Eq. SW - 120 μ s (EX) 70 μ s (SX/ZX) Dolby NR SW - OUT MPX SW - OUT	Main P.C.B. L104, L204	<ol style="list-style-type: none"> 1. Feed in 400 Hz (0 dB) and adjust input level controls to obtain 0 dB on the level meters. 2. Switch the Generator output level to -20 dB, then record and play it back. 3. Feed in 20 Hz to 18 kHz (-20 dB), then check to insure if the output levels are within -20 dB \pm 4 dB. 4. If above is not sufficient, adjust L104 (L204) to obtain approx. -20 dB on the VTVM. 5. Conduct step 13. "Record Level Calibration and Recording Bias Current Adjustment". 6. If above is not sufficient, precise re-adjustment of step 7 "Playback Frequency Response", replacement of Playback Head or Record Head, or check on item 5.9 "Tape Travelling Adjustment" will be required.
15	Crosstalk	1 kHz to INPUT Jacks	1 kHz Band Pass Filter and VTVM to OUTPUT Jacks	Record and Playback Tape SW - SX Eq. SW - 70 μ s Dolby NR SW - OUT MPX SW - IN		<ol style="list-style-type: none"> 1. Erase the tape with bulk eraser. 2. Adjust the input level controls to obtain 0 dB on the level meters, and record the signals on the reference SX tape (DA09025A). 3. Turn the cassette tape the other way round and play it back. 4. Measure the difference between 2 and 3.
16	Channel Separation	1 kHz to INPUT Jacks	Same as above	Same as above		<ol style="list-style-type: none"> 1. Erase the tape with bulk eraser. 2. Adjust L ch (R ch) input level control to obtain 0 dB on the level meter, and close R ch (L ch) input level control. 3. Record and play it back, then measure the R ch (L ch) level.
17	Erasure	100 Hz to INPUT Jacks	100 Hz Band Pass Filter and VTVM to OUTPUT Jacks	Record and Playback Tape SW - ZX Eq. SW - 70 μ s Dolby NR SW - IN MPX SW - IN		<ol style="list-style-type: none"> 1. Erase the tape with bulk eraser. 2. Adjust input level controls to obtain 0 dB on the level meters, and record the signals on the reference ZX tape (DA09037A). 3. Rewind the tape, close input level controls, and then re-record again. 4. Rewind the tape, play it back, and then measure the difference between 2 and 3.

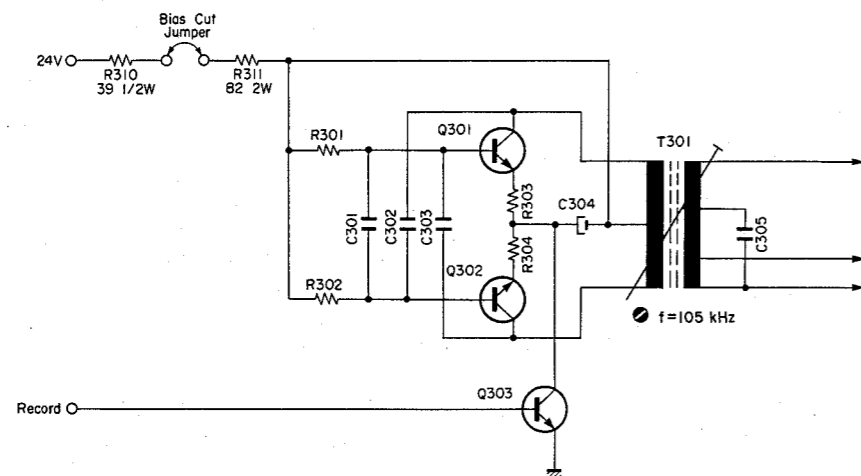

Fig. 7.4
8. Bias Oscillation Frequency and Erase Current

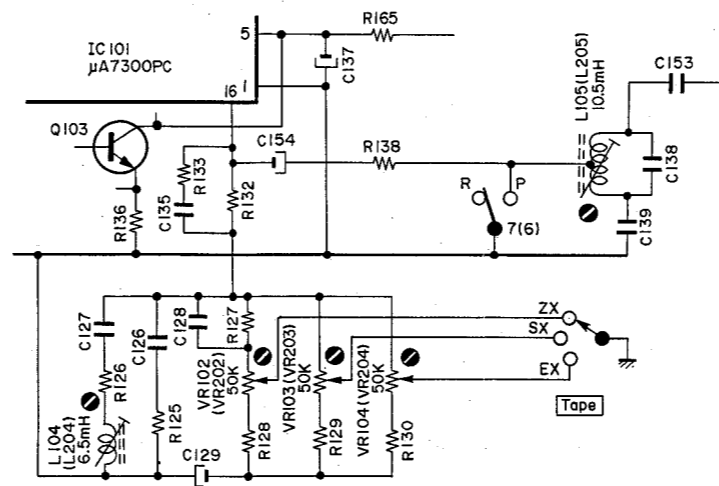

Fig. 7.5
9. Record Amplifier Equalizer
10. Bias Trap
14. Overall Frequency Response

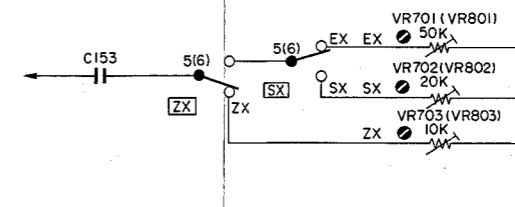

Fig. 7.6
13. Record Level Calibration and Recording Bias Current

STEP	ITEM	SIGNAL SOURCE	OUTPUT CONNECTION	MODE	ADJUSTMENT	REMARKS
18	Signal to Noise Ratio	400 Hz to INPUT Jacks	IHF-A Curve Filter, Distortion Meter and VTVM to OUTPUT Jacks	Record and Playback Tape SW - ZX Eq. SW - 70 μ s Dolby NR SW - IN MPX SW - IN		1. Feed in 400 Hz and record, and play it back. 2. Adjust the input level controls to obtain 3% total harmonic distortion in playback mode. 3. Close the input level controls then record. 4. After rewind, play back and check the output level difference between 2 and 3. Note: The filter of IHF-A curve shall be used in the measurements.
19	Total Harmonic Distortion	400 Hz to INPUT Jacks	Distortion Meter to OUTPUT Jacks	Record and Playback Tape SW - EX/SX/ZX Eq. SW - 120 μ s (EX) 70 μ s (SX, ZX) Dolby NR SW - OUT MPX SW - IN		1. Adjust the input level controls to obtain 0 dB on the level meters. 2. Record and play it back. 3. Read the distortion meter and check to insure that the distortion is as follows: EXII 1.0% or less SX 1.0% or less ZX 0.9% or less
20	Wow/Flutter	3 kHz Speed and Wow/Flutter Tape (DA09006A)	Wow/Flutter Meter to OUTPUT Jacks	Playback Eq. SW - 70 μ s		Playback and read the wow/flutter meter.

7.2. Playback Frequency Response Adjustment

Fig. 7.7 shows the playback equalization curve for the N-481, and Fig. 7.8 is the circuit for adjustment.

(1) Level Adjustment (for middle frequency response)

This adjustment will be required when playback level is not sufficient at 10 kHz PB Frequency Response Tape (refer to step 7 in "7.1 Adjustment and Measurement Instructions").

Playback equalization level can be varied by the modification of R108 (R208) and R109 (R209).

Following are the details for level modification:

- Approx. +1 dB R108 (R208): 3.0 K
R109 (R209): 4.3 K
- 0 dB R108 (R208): 2.7 K
R109 (R209): 3.9 K
- Approx. -1 dB R108 (R208): 2.4 K
R109 (R209): 3.6 K

(2) Peaking Adjustment (for high frequency response)

This adjustment will be required when playback level is not sufficient at 20 kHz PB Frequency Response Tape (refer to step 7 in "7.1. Adjustment and Measurement Instructions").

Peaking portion compensates the gap loss of the playback head. Peaking level is varied by the short circuit of R112 (R212) or R111 (R211) as illustrated in the figure.

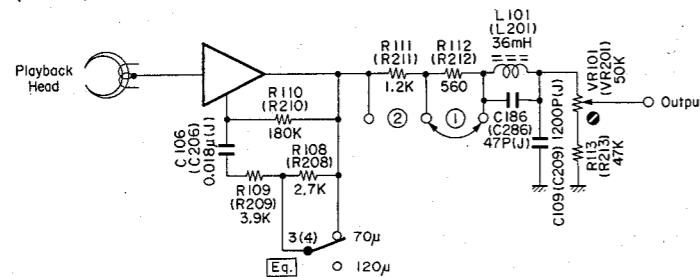

Fig. 7.8 Playback Amp.

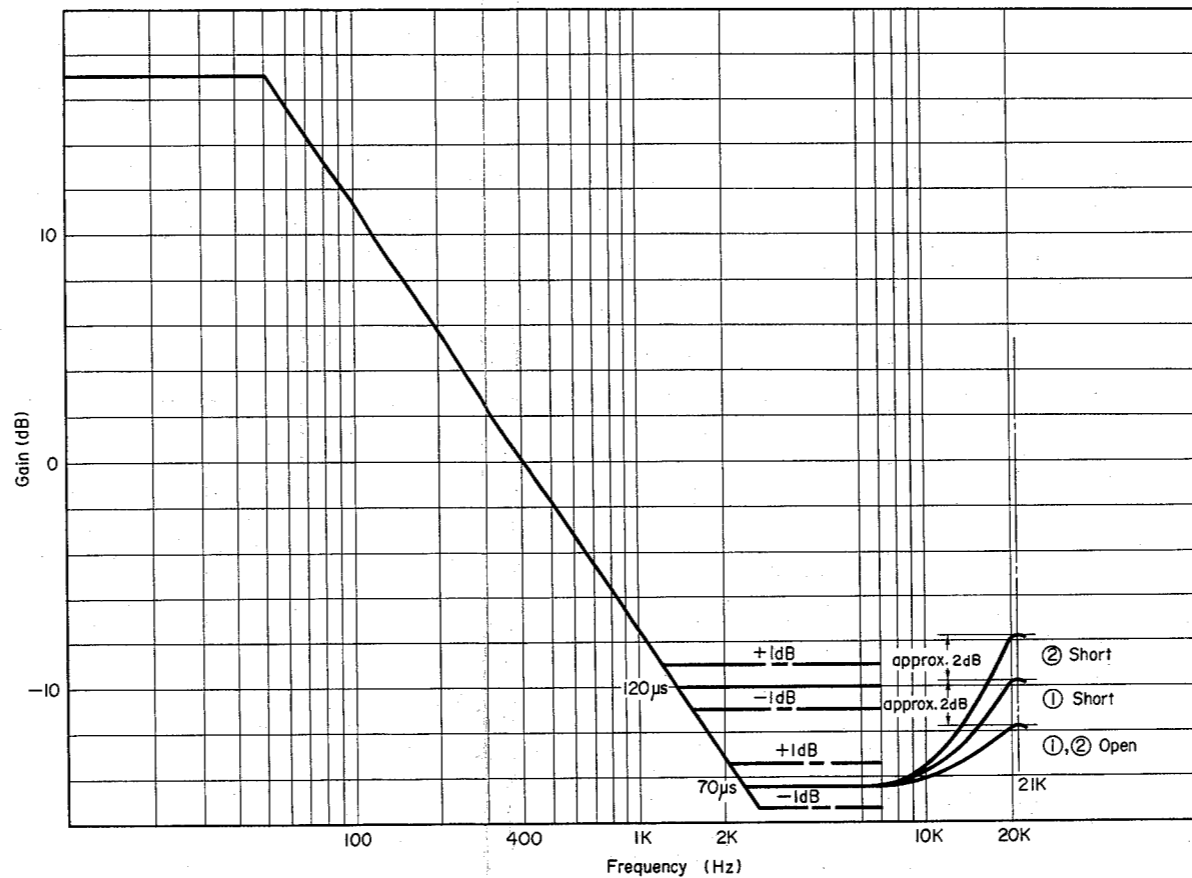

Fig. 7.7 Playback Equalization Curve

7.3. Check on Dolby NR Circuit

Dolby NR Circuit incorporates a Dolby B-Type NR IC (μ A7300PC) which has no adjustment point.

Perform the following checks and make sure that the IC operates accurately i.e., frequency response through IC is accurate.

- Signal Source: 5 kHz to INPUT Jacks
- Output Connection: VTVM to the output side of C154 (C254) on the Main P.C.B.
- Mode: Record Pause
MPX SW - IN

- (1) Remove the Bias-cut Jumper from the dip side of the Main P.C.B.
- (2) Connect a VTVM to TP101 (TP201) on the Main P.C.B.
Feed in 5 kHz and adjust the input level so that the VTVM may read 100 mV (0 dB) at each Test Point.
- (3) Remove the VTVM from TP101 (TP201) and reconnect it to the output side of C154 (C254).
- (4) Decrease the input level (0 dB) by 20 dB or 30 dB. Check to insure that the level at output side of C154 (C254) corresponds to the following with the Dolby NR Switch IN and OUT.
- (5) After completion of the adjustment, reconnect the Bias-cut Jumper.

Input Level	Capacitor Output Level		
(f=5 kHz)	Dolby NR OUT	Dolby NR IN	Difference between IN and OUT
-20 dB	-20 dB	-16.8 dB \pm 1.5 dB	3.2 dB \pm 1.5 dB
-30 dB	-30 dB	-21.8 dB \pm 1.5 dB	8.2 dB \pm 1.5 dB

8. MOUNTING DIAGRAMS AND PARTS LIST

Note: Mounting diagram shows a dip side view of the printed circuit board.

8.1. Volume P.C.B. Ass'y

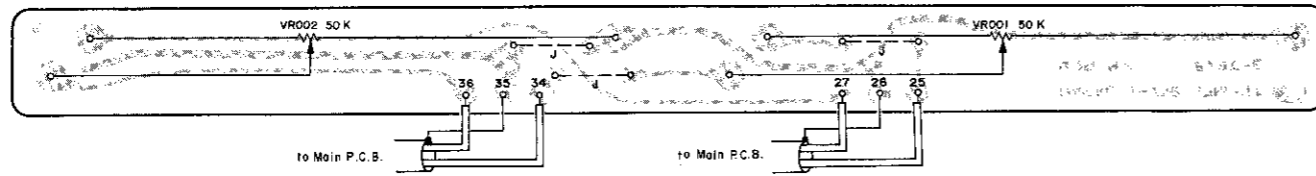

Fig. 8.1

8.2. Control Switch P.C.B. Ass'y

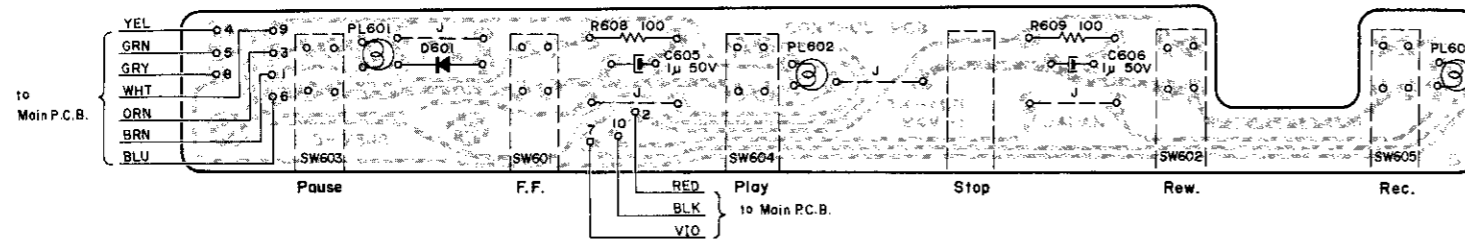
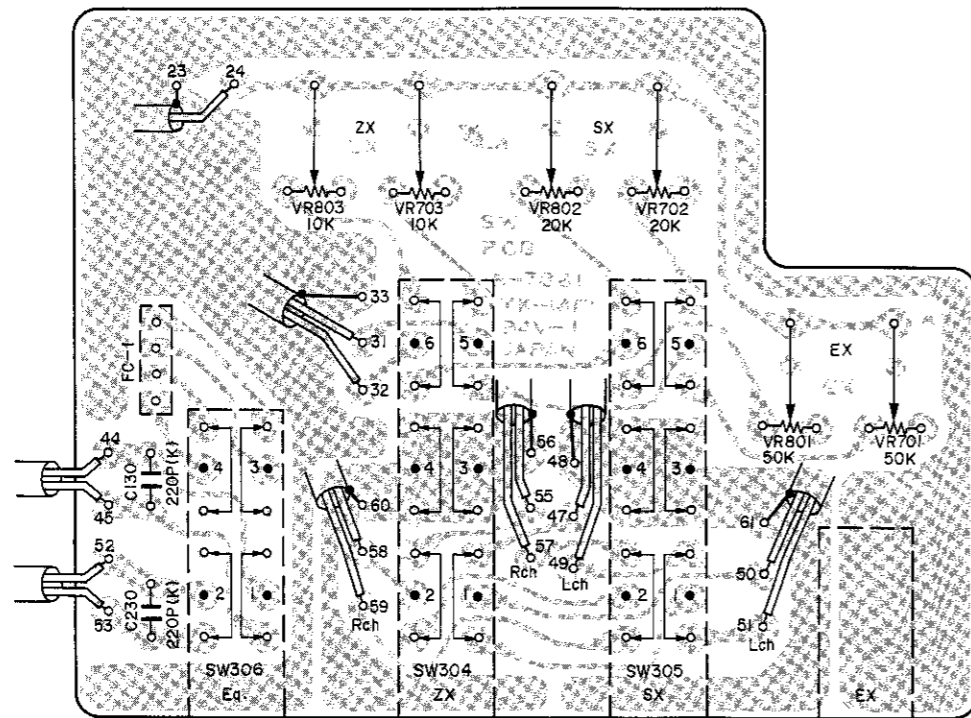

Fig. 8.2

Note: Diode is 1SS53 unless otherwise specified.

8.3. Switch P.C.B. Ass'y



Note: All the wires are connected to the Main P.C.B. Ass'y.

Fig. 8.3

8.4. Control P.C.B. Ass'y

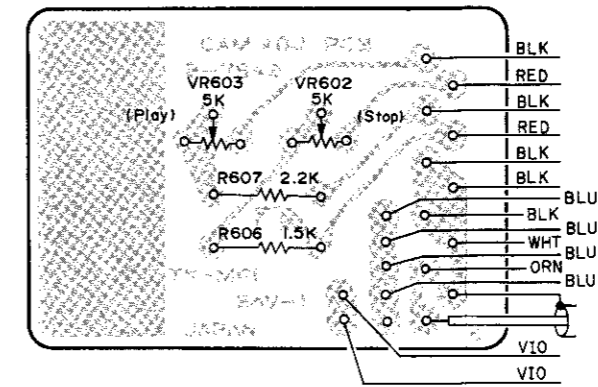

Fig. 8.4

8.5. Auto Shut-off P.C.B. Ass'y

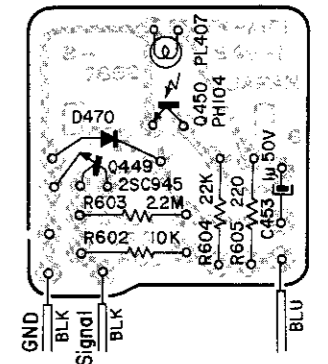

Fig. 8.5

Note: Diode is 1SS53 unless otherwise specified.

8.6. Lamp P.C.B. L Ass'y

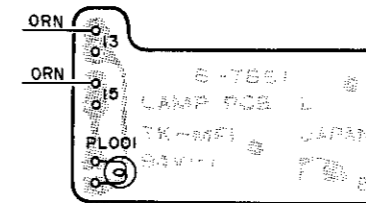

Fig. 8.6

8.7. Lamp P.C.B. R Ass'y

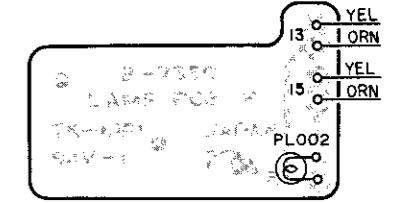
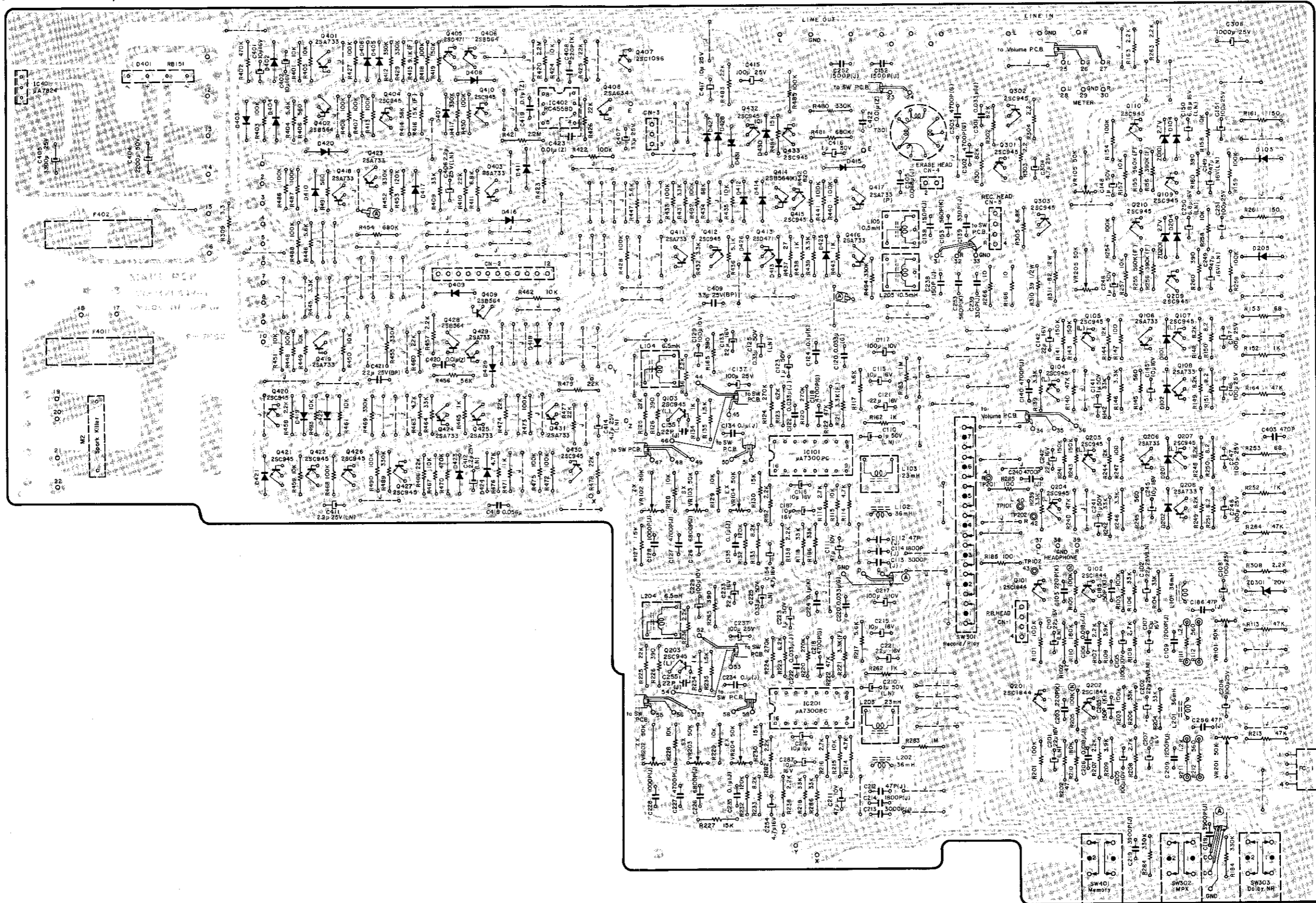

Fig. 8.7

Schematic Ref. No.	Part No.	Description	Schematic Ref. No.	Part No.	Description
	BA04114A	Volume P.C.B. Ass'y		BA04128A	Auto Shut-off P.C.B. Ass'y
VR101,201	0B07845B	Volume P.C.B.	Q449	0B07852B	Auto Shut-off P.C.B.
	0B07298A	Slide Volume 50K (A)	Q450	0B06100A	Transistor 2SC945 (A)
	BA04126A	Control P.C.B. Ass'y	D470	0B06228A	Photo Transistor PH104
VR602,603	0B07849B	Control P.C.B.	0B06181A	0B06181A	Silicon Diode 1SS53
R606	0B09059A	Semi-fixed Volume 5K	R602	0B01888A	Carbon Resistor 10K ERD-25T J
R607	0B05698A	Carbon Resistor 1.5K ERD-25T J	R603	0B05671A	Carbon Resistor 2.2M ERD-25T J
	0B05622A	Carbon Resistor 2.2K ERD-25T J	R604	0B05615A	Carbon Resistor 22K ERD-25T J
	BA04154A	Switch P.C.B. Ass'y	R605	0B01933A	Carbon Resistor 220 ERD-25T J
VR701,801	0B07861A	Switch P.C.B.	C453	0B01405A	Electrolytic Capacitor 1μ 50V
VR702,802	0B07237A	Semi-fixed Volume 50K	PL407	0B08552A	Lamp 12V 25mA
VR703,803	0B07261A	Semi-fixed Volume 20K		BA04125A	Lamp P.C.B. L Ass'y
C130, 230	0B07236A	Semi-fixed Volume 10K	PL001	0B07851B	Lamp P.C.B. L
SW304	0B09283A	Ceramic Capacitor 220P 50V K		0B08674A	Lamp 5V 200mA
	0B07314A	Push Switch 0-6-6-4		BA04124A	Lamp P.C.B. R Ass'y
	0B08707A	Flat Cable 80 (1 pce.)	PL002	0B07850B	Lamp P.C.B. R
	BA04113A	Control Switch P.C.B. Ass'y		0B08674A	Lamp 5V 200mA
D601	0B07848B	Control Switch P.C.B.			
R608, 609	0B06181A	Silicon Diode 1SS53			
C605, 606	0B01679A	Carbon Resistor 100 ERD-25T J			
PL601,602	0B01405A	Electrolytic Capacitor 1μ 50V			
603	0B08673A	Lamp 24V 20mA			
	0B07297A	Control Switch (1 pce.)			

8.8. Main P.C.B. Ass'y



Note: Diode is 1SS53 unless otherwise specified.

Fig. 8.8.1 Serial No.: A30605220 -

Description	Schematic Ref. No.	Part No.	Description	Schematic Ref. No.	Part No.	Description	Schematic Ref. No.	Part No.	Description	Schematic Ref. No.	Part No.	Description
ytic Capacitor 47µ 10V	R140, 164	OB05641A	Carbon Resistor 47K ERD-25T J	Q401, 403	OB06013A	Transistor 2SA733	R436	OB09314A	Carbon Resistor 5.1K ERD-25T J		OB07318A	Push Switch A306 A (1 pce.)
pacitor 47P 50V J	240, 264			411, 416			R437	OB09384A	Fail Safe Type Resistor 27 ERD-14F J		OB08675A	Pin Jack A304 (1 pce.)
capitor 3000P 50V J	R141, 143	OB05626A	Carbon Resistor 150K ERD-25T J	418, 419			R438, 443	OB01857A	Carbon Resistor 1K ERD-25T J		OB08676A	Heat Sink A304 (1 pce.)
apacitor 1800P 50V J	241, 243			423, 424			465, 471				OB08680A	Heat Sink A (1 pce.)
ytic Capacitor 10µ 16V	R142, 242	OB05509A	Carbon Resistor 33K ERD-25T J	425, 429			R442	OB01680A	Carbon Resistor 820 ERD-25T J		OC08144C	Record Spring (1 pce.)
	R144, 244	OB09263A	Carbon Resistor 12K ERD-25T J	431			R453	OB05621A	Carbon Resistor 120K ERD-25T J		OB08569C	Record Wire Holder (1 pce.)
	R145, 245	OB05575A	Carbon Resistor 560 ERD-25T J	Q402, 406	OB06069A	Transistor 2SB564	R454, 481	OB09335A	Carbon Resistor 680K ERD-25T J		OB08570A	Record Spring Holder (1 pce.)
	R147, 185	OB01679A	Carbon Resistor 100 ERD-25T J	409, 428			R457, 458	OB05622A	Carbon Resistor 2.2K ERD-25T J		OB08573A	Wire Holder (1 pce.)
	247, 285			Q404, 410	OB06100A	Transistor 2SC945 (A)	R463, 476	OB01846A	Carbon Resistor 4.7K ERD-25T J		OM03782A	Fuse Label 1A 250V (1 pce.) (U.S.A., Canada, Japan & Others)
	R148, 149	OB01856A	Carbon Resistor 8.2K ERD-25T J	412, 415			R470	OB01684A	Carbon Resistor 470K ERD-25T J		OM04082B	Fuse Label T 125mA 250V (1 pce.) (UK, Australia & 220V Class 2)
	248, 249			420, 421			R484	OB01683A	Carbon Resistor 15K ERD-25T J		OM04100B	Fuse Label T 500mA 250V (1 pce.) (U.S.A., Canada, Japan & Others)
	R150, 151	OB09331A	Fail Safe Type Resistor 8.2 RDF-25S J	422, 426			C403	OB09286A	Ceramic Capacitor 470P 50V K		OM04096B	Fuse Label T 500mA 250V (1 pce.) (220V Class 2)
	250, 251			427, 430			C406, 411	OB09332A	Electrolytic Capacitor 2.2µ 25V (LN)		OM04096A	Fuse Label T 500mA 250V (1 pce.) (UK & Australia)
	R152, 252	OB01857A	Carbon Resistor 1K ERD-25T J	433			C412				OB08349A	Fuse Clip (4 pcs.) (UK, Australia & 220V Class 2)
	OB09306A	Fail Safe Type Resistor 68 RDF-25S J		Q405, 413	OB06066A	Transistor 2SD471	C407	OB09251A	Electrolytic Capacitor 33µ 25V		OE00117A	Washer 2mm (1 pce.)
	OB05622A	Carbon Resistor 2.2K ERD-25T J		Q407	OB06020A	Transistor 2SC1096	C408	OB09283A	Ceramic Capacitor 220P 50V K		OE00172A	Washer 3mm Toothed Lock (1 pce.)
	OB05652A	Mylar Capacitor 4700P 50V J		Q408	OB06012A	Transistor 2SA634	C409	OB09345A	Electrolytic Capacitor 3.3µ 25V (BP)		OE00788A	BT Screw M2x8 Philips Pan Head (1 pce.)
	OB01405A	Electrolytic Capacitor 1µ 50V		Q414	OB06252A	Transistor 2SB564 (K)	C414	OB09333A	Electrolytic Capacitor 4.7µ 25V (LN)		OE00831A	BT Screw M3x10 Philips Pan Head (1 pce.)
	OB01862A	Electrolytic Capacitor 22µ 16V		Q417	OB06155A	Transistor 2SA733 (P)	C415	OB01272A	Electrolytic Capacitor 100µ 25V		OE00857A	BT Screw M3x6 Philips Binding Head (2 pcs.)
	OB01412A	Electrolytic Capacitor 10µ 16V		Q432	OB06251A	Transistor 2SC945A (Q)	C416	OB01405A	Electrolytic Capacitor 1µ 50V		OE00612A	Screw M3x6 Philips Pan Head (2A)
	OB01272A	Electrolytic Capacitor 100µ 25V		D403-431	OB06181A	Silicon Diode 1SS53 (29 pcs.)	C417	OB01674A	Electrolytic Capacitor 10µ 25V		OE00507A	Nut Hex. M3 (2 pcs.)
	C152, 252	OB05653A	Mylar Capacitor 1500P 50V J	R403, 407	OB01889A	Carbon Resistor 100K ERD-25T J	C418	OB01676A	Mylar Capacitor 0.056µ 50V			
				408, 413			C419	OB09292A	Ceramic Capacitor 0.1µ 50V Z			
				418, 422			C420, 422	OB09290A	Ceramic Capacitor 0.01µ 50V Z			
				427, 428			423					
				430, 433			C421	OB09368A	Electrolytic Capacitor 22µ 25V (BP)			
				440, 441								
				448, 468								
				472, 473								
				475, 485								
				486, 487								
				488, 490								
				492								
				R404, 446	OB01887A	Carbon Resistor 5.6K ERD-25T J	IC401	OB06237A	Regulator +24V µA7824			
				447			D401	OB06183A	Diode Bridge RB151			
				R405, 424	OB01888A	Carbon Resistor 10K ERD-25T J	D402	OB06181A	Silicon Diode 1SS53			
				435, 449			R309	OB09339A	Fail Safe Type Resistor 3.3 RSF-25S J			
				450, 451			R401	OB01888A	Carbon Resistor 10K ERD-25T J			
				459, 461			R402	OB01684A	Carbon Resistor 470K ERD-25T J			
				462, 467			C306	OB01870A	Electrolytic Capacitor 1000µ 25V			
				493			C401, 402	OB01412A	Electrolytic Capacitor 10µ 16V			
				R406, 491	OB05575A	Carbon Resistor 560 ERD-25T J	C404	OB09336A	Electrolytic Capacitor 2200µ 50V			
				R409, 464	OB05509A	Carbon Resistor 33K ERD-25T J	C405	OB09373A	Electrolytic Capacitor 3300µ 25V			
				R410, 425	OB05615A	Carbon Resistor 22K ERD-25T J						
				426, 460								
				466, 474								
				477, 478								
				479, 483								
				R411	OB01682A	Carbon Resistor 6.8K ERD-25T J						
				R412, 417	OB05627A	Carbon Resistor 330K ERD-25T J						
				429, 452								
				455, 469								
				480, 489								
				494								
				R414, 456	OB05508A	Carbon Resistor 56K ERD-25T J						
				R415	OB09328A	Metal Film Resistor 9.1K SN14K2E F						
				R416	OB09340A	Metal Film Resistor 15K SN14K2E F						
				R419	OB05626A	Carbon Resistor 150K ERD-25T J						
				R420, 421	OB05671A	Carbon Resistor 2.2M ERD-25T J						
				R423	OB09214A	Fail Safe Type Resistor 1 RDF-25S J						
				R431, 432	OB01681A	Carbon Resistor 3.3K ERD-25T J						
				439, 445								
				R434	OB05692A	Carbon Resistor 68K ERD-25T J						

Description	Schematic Ref. No.	Part No.	Description	Schematic Ref. No.	Part No.	Description	Schematic Ref. No.	Part No.	Description	Schematic Ref. No.	Part No.	Description
47P 50V J	R140, 164	OB05641A	Carbon Resistor 47K ERD-25T J	411, 416			R437	OB09049A	Fail Safe Type Resistor 22 ERD-14F J	SW301	OB07316A	Record Switch
3000P 50V J	240, 264			417, 418			R438	OB05614A	Carbon Resistor 1.8K ERD-25T J		OB07318A	Push Switch A306 A (1 pce.)
1800P 50V J	R141, 143	OB05626A	Carbon Resistor 150K ERD-25T J	419, 423			R443, 465	OB01857A	Carbon Resistor 1K ERD-25T J		OB08675A	Pin Jack A304 (1 pce.)
Capacitor 10μ 16V	241, 243			424, 425			471				OB08676A	Heat Sink A304 (1 pce.)
	R142, 242	OB05509A	Carbon Resistor 33K ERD-25T J	429, 431			R453	OB05621A	Carbon Resistor 220K ERD-25T J		OB08680B	Heat Sink A (1 pce.)
Capacitor 100μ 10V	R144, 244	OB09263A	Carbon Resistor 12K ERD-25T J	Q402, 406	OB06069A	Transistor 2SB564	R454, 481	OB09335A	Carbon Resistor 680K ERD-25T J		OC08144C	Record Spring (1 pce.)
4700P 100V G	R145, 245	OB05575A	Carbon Resistor 500 ERD-25T J	409, 428			R457, 458	OB05622A	Carbon Resistor 2.2K ERD-25T J		OB08569C	Record Wire Holder (1 pce.)
3900P 50V J	R147, 185	OB01679A	Carbon Resistor 1.1K ERD-25T J	Q404, 410	OB06100A	Transistor 2SC945	R463, 476	OB01846A	Carbon Resistor 4.7K ERD-25T J		OB08570A	Record Spring Holder (1 pce.)
0.033μ 100V G	247, 285			412, 415			R470	OB01684A	Carbon Resistor 470K ERD-25T J		OB08573A	Wire Holder (1 pce.)
Capacitor 22μ 16V	R148, 149	OB01856A	Carbon Resistor 8.2K ERD-25T J	420, 421			R484	OB01683A	Carbon Resistor 15K ERD-25T J		OM03782A	Fuse Label 1A 250V (U.S.A., Canada, Japan & Others) (1 pce.)
0.033μ 50V J	248, 249			422, 426			C403	OB09286A	Ceramic Capacitor 470P 50V K			
Capacitor 1μ 50V	R150, 151	OB09331A	Fail Safe Type Resistor 8.2 RDF-25S J	427, 430			C406, 411	OB09332A	Electrolytic Capacitor 2.2μ 25V (LN)			
0.1μ 50V K	250, 251			433			412				OM04082B	Fuse Label T 125mA 250V (UK, Australia & 220V Class 2) (1 pce.)
Capacitor 0.33μ 50V (LN)	R152, 252	OB01857A	Carbon Resistor 1K ERD-25T J	Q405, 413	OB06066A	Transistor 2SD471	C407	OB09251A	Electrolytic Capacitor 33μ 25V			
Capacitor 100μ 25V	R153, 253	OB09306A	Fail Safe Type Resistor 68 RDF-25S J	Q407	OB06020A	Transistor 2SC1096	C408	OB09283A	Ceramic Capacitor 220P 50V K		OM04100B	Fuse Label T 500mA 250V (U.S.A., Canada, Japan & Others) (1 pce.)
	R163, 263	OB05622A	Carbon Resistor 2.2K ERD-25T J	Q408, 414	OB06012A	Transistor 2SA634	C409	OB09345A	Electrolytic Capacitor 3.3μ 25V (BP)			
	C140, 240	OB05652A	Mylar Capacitor 4700P 50V J	Q432	OB06251A	Transistor 2SC945A (Q)	C414	OB09333A	Electrolytic Capacitor 4.7μ 25V (LN)			
	C141, 241	OB01405A	Electrolytic Capacitor 1μ 50V	D403-429	OB06181A	Silicon Diode 1SS53 (27 pcs.)	C415	OB01272A	Electrolytic Capacitor 100μ 25V		OM04096B	Fuse Label T 500mA 250V (220V Class 2) (1 pce.)
2SC945 (L)	C142, 242	OB01862A	Electrolytic Capacitor 22μ 16V	R403, 407	OB01889A	Carbon Resistor 100K ERD-25T J	C416	OB01405A	Electrolytic Capacitor 1μ 50V			
10.5mH	C145, 245	OB01412A	Electrolytic Capacitor 10μ 16V	408, 413			C417	OB01674A	Electrolytic Capacitor 10μ 25V		OM04096A	Fuse Label T 500mA 250V (UK & Australia) (1 pce.)
	C147, 247	OB01272A	Electrolytic Capacitor 100μ 25V	418, 422			C418	OB01676A	Mylar Capacitor 0.056μ 50V			
Time 50K	C152, 252	OB05653A	Mylar Capacitor 1500P 50V J	427, 428			C419	OB09292A	Ceramic Capacitor 0.1μ 50V Z		OB08349A	Fuse Clip (UK, Australia & 200V Class 2) (4 pcs.)
				430, 433			C420	OB09290A	Ceramic Capacitor 0.01μ 50V Z			
				440, 441			C421	OB09368A	Electrolytic Capacitor 22μ 25V (BP)			
				448, 468							OE00117A	Washer 2mm (1 pce.)
22K ERD-25T J	Q109, 110	OB06100A	Transistor 2SC945 (A)	472, 473							OE00172A	Washer 3mm Toothed Lock (1 pce.)
390 ERD-25T J	209, 210			475, 485							OE00788A	BT Screw M2x8 Philips Pan Head (1 pce.)
15K ERD-25T J	ZD101,201	OB06191A	Zener Diode 2.7EB	486, 487			IC401	OB06237A	Regulator +24V μA7824			
	D104, 105	OB06181A	Silicon Diode 1SS53	488, 490			D401	OB06183A	Diode Bridge RB151		OE00831A	BT Screw M3x10 Philips Pan Head (1 pce.)
	204, 205			492			D402	OB06181A	Silicon Diode 1SS53			
10K ERD-25T J	VR105,205	OB07237A	Semi-fixed Volume 50K	R404, 446	OB01887A	Carbon Resistor 5.6K ERD-25T J	R309	OB09339A	Fail Safe Type Resistor 3.3 RSF-25S J		OE00857A	BT Screw M3x6 Philips Binding Head (2 pcs.)
120K ERD-25T J	R154, 159	OB01889A	Carbon Resistor 100K ERD-25T J	447			R401	OB01888A	Carbon Resistor 10K ERD-25T J			
8.2K ERD-25T J	254, 259			R405, 424	OB01888A	Carbon Resistor 10K ERD-25T J	R402	OB01684A	Carbon Resistor 470K ERD-25T J		OE00612A	Screw M3x6 Philips Pan Head (2A) (2 pcs.)
1K ERD-25T J	R155, 255	OB09318A	Metal Film Resistor 560K SN14K2E F	435, 449			C306	OB01870A	Electrolytic Capacitor 1000μ 25V			
1.5K ERD-25T J	R156, 256	OB09338A	Metal Film Resistor 390K SN14K2E F	450, 451			C401, 402	OB01412A	Electrolytic Capacitor 10μ 16V		OE00507A	Nut Hex. M3 (2 pcs.)
2.2K ERD-25T J	R157, 158	OB01888A	Carbon Resistor 10K ERD-25T J	459, 461			C404	OB09336A	Electrolytic Capacitor 2200μ 50V			
	257, 258			462, 467			C405	OB09373A	Electrolytic Capacitor 3300μ 25V			
	R160, 260	OB05691A	Carbon Resistor 390 ERD-25T J	493								
10 ERD-25T J	R161, 261	OB09213A	Fail Safe Type Resistor 150 RDF-25S J	R406, 491	OB05575A	Carbon Resistor 560 ERD-25T J						
6800P 50V J	C148, 248	OB01405A	Electrolytic Capacitor 1μ 50V	R409, 464	OB05509A	Carbon Resistor 33K ERD-25T J						
4700P 50V J	C149, 249	OB09218A	Electrolytic Capacitor 47μ 16V (LN)	R410, 425	OB05615A	Carbon Resistor 22K ERD-25T J						
1000P 50V J	C150, 250	OB09219A	Electrolytic Capacitor 6.8μ 16V (LN)	426, 442								
Capacitor 100μ 10V	C151, 251	OB01270A	Electrolytic Capacitor 100μ 25V	460, 466								
Capacitor 22μ 16V				474, 477								
0.1μ 50V J				478, 479								
				483								
150P 50V J	Q301, 302	OB06100A	Transistor 2SC945 (A)	R411, 439	OB01682A	Carbon Resistor 6.8K ERD-25T J	F401	OB08374A	Fuse 1A 250V (U.S.A., Canada & Others)			
330P 100V J	303			R412, 417	OB05627A	Carbon Resistor 330K ERD-25T J	F401	OB08686A	Fuse 1A 250V (Japan)			
tor 560P 50V K	T301	OB06613A	Osc. Coil	429, 452			F401	OB08275A	Fuse T 125mA 250V (UK, Australia & 220V Class 2)			
Capacitor 4.7μ 16V	R301, 302	OB05668A	Carbon Resistor 82K ERD-25T J	455, 469			F402	OB08698A	Fuse T 500mA 250V (U.S.A., Canada & Others)			
	R303, 304	OB09212A	Fail Safe Type Resistor 2.2 RDF-25S J	480, 489			F402	OB08697A	Fuse T 500mA 250V (Japan)			
	R305	OB01682A	Carbon Resistor 6.8K ERD-25T J	494			F402	OB08457A	Fuse T 500mA 250V (UK, Australia & 220V Class 2)			
	R310	OB09296A	Fail Safe Type Resistor 39 RSF-1/2B J	R414, 456	OB05508A	Carbon Resistor 56K ERD-25T J						
2SC945 (L)	R311	OB09295A	Fail Safe Type Resistor 82 RSF-2B J	R415	OB09328A	Metal Film Resistor 9.1K SN14K2E F						
	C301	OB05583A	Mylar Capacitor 0.033μ 50V J	R416	OB09340A	Metal Film Resistor 15K SN14K2E F	M2	OB08342A	Spark Killer (U.S.A. & Canada)			
	C302, 303	OB09191A	PP Capacitor 4700P 100V G	R419	OB05626A	Carbon Resistor 150K ERD-25T J	M2	OB08363A	Spark Killer (Japan)			
2SA733	C304	OB01402A	Electrolytic Capacitor 4.7μ 25V	R420, 421	OB05671A	Carbon Resistor 2.2M ERD-25T J	M2, 3	OB08445A	Spark Killer (220V Class 2)			
	C305	OB09254A	PP Capacitor 0.068μ 100V J	R423	OB09214A	Fail Safe Type Resistor 1 RDF-25S J	M2	OB08240U	Spark Killer (UK, Australia & Others)			
1SS53				R431, 432	OB01681A	Carbon Resistor 3.3K ERD-25T J						
				445								
3.3K ERD-25T J	IC402	OB06124B	IC RC4558D	R434	OB05692A	Carbon Resistor 68K ERD-25T J	CN1, 5	OB08654A	4P-T Post			
	Q401, 403	OB06013A	Transistor 2SA733	R436	OB09314A	Carbon Resistor 5.1K ERD-25T J	CN2	OB08681A	12P-T Post			
							CN3	OB08653A	3P-T Post			
							CN4	OB08656A	2P-T Post			

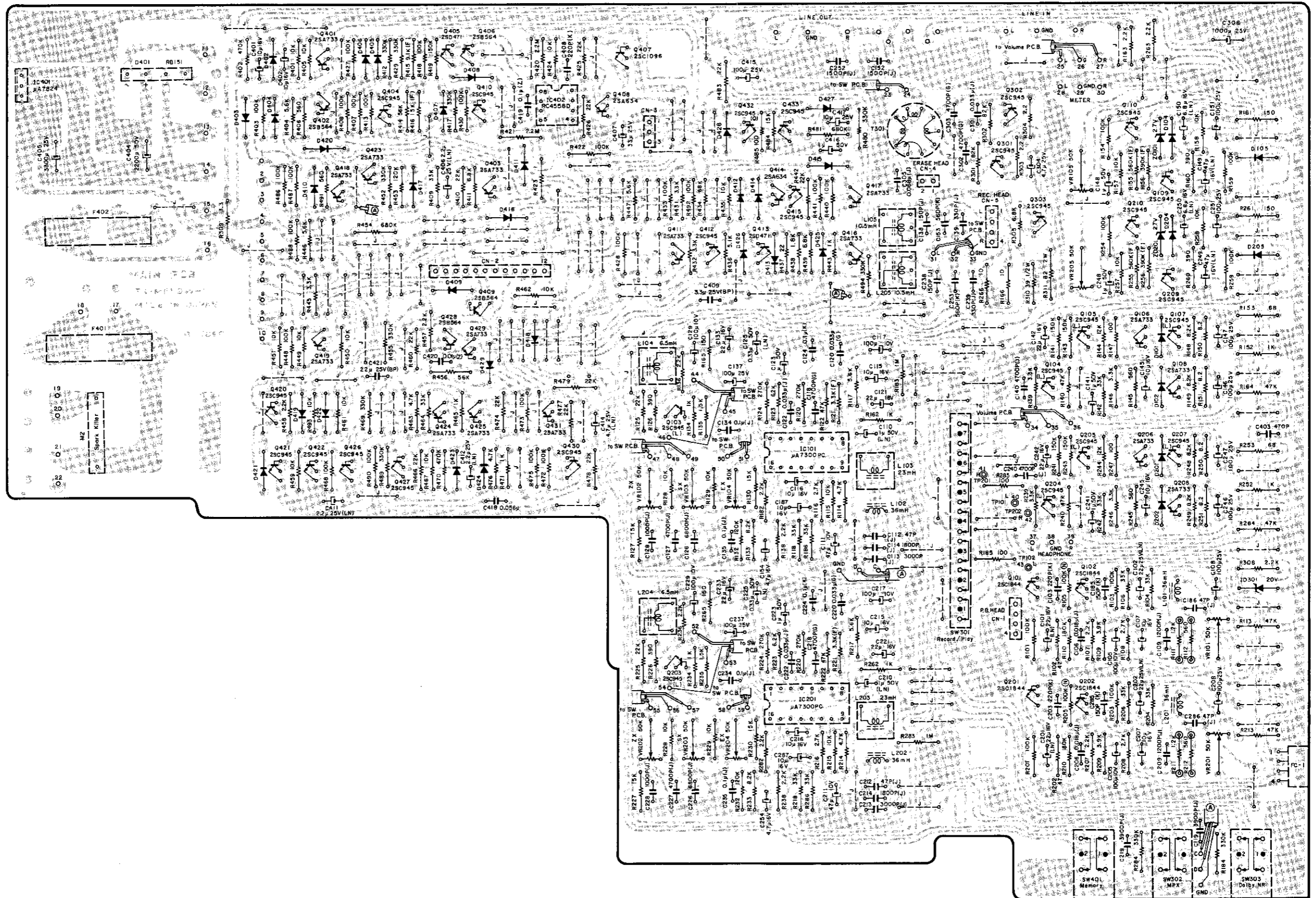

Note: Diode is 1SS53 unless otherwise specified.

Fig. 8.8.2 Serial Nos.: A30601001 – A30605219

9. MECHANISM ASS'Y AND PARTS LIST

9.1. Synthesis

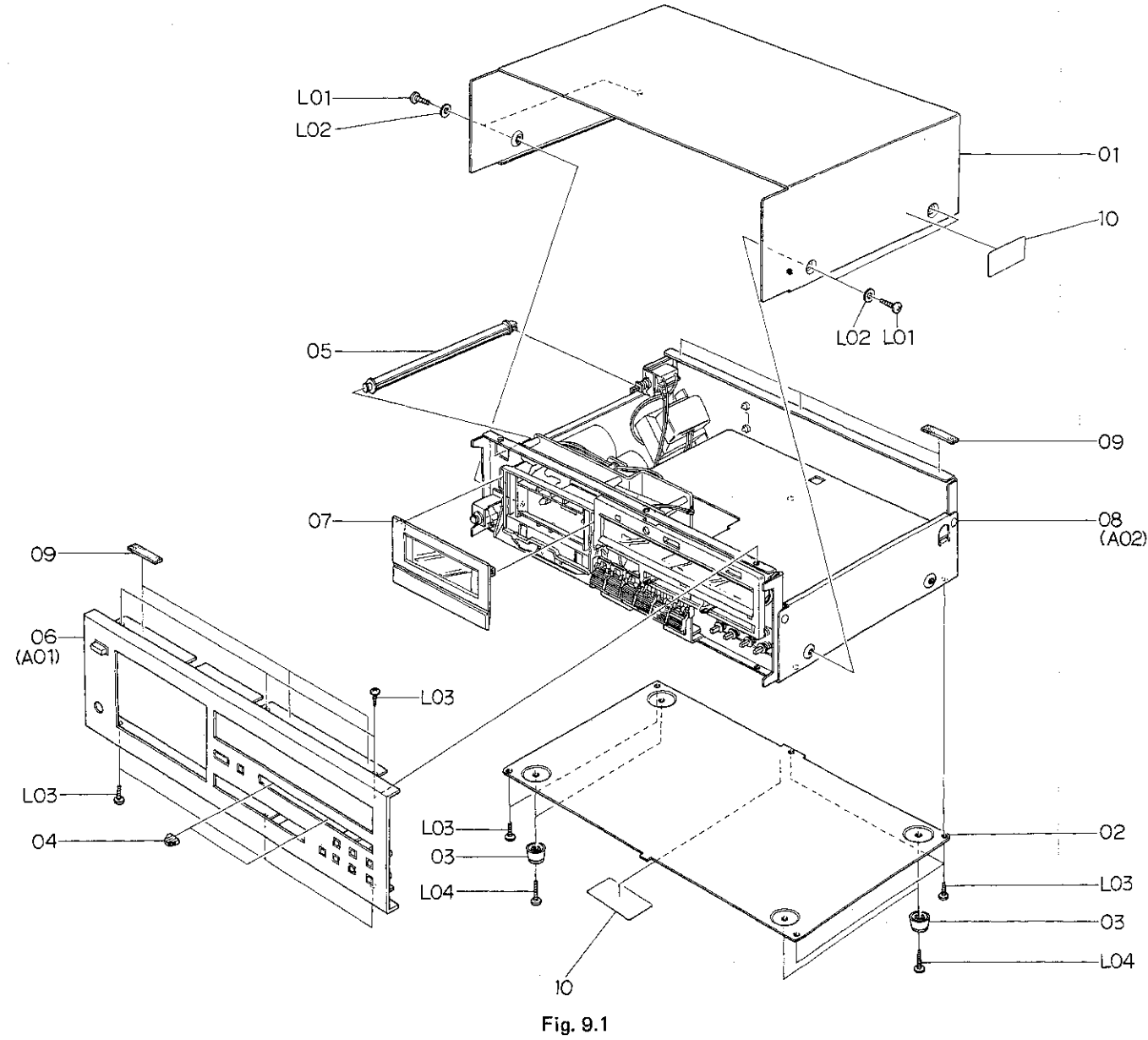

9.2. Front Panel Ass'y (A01)

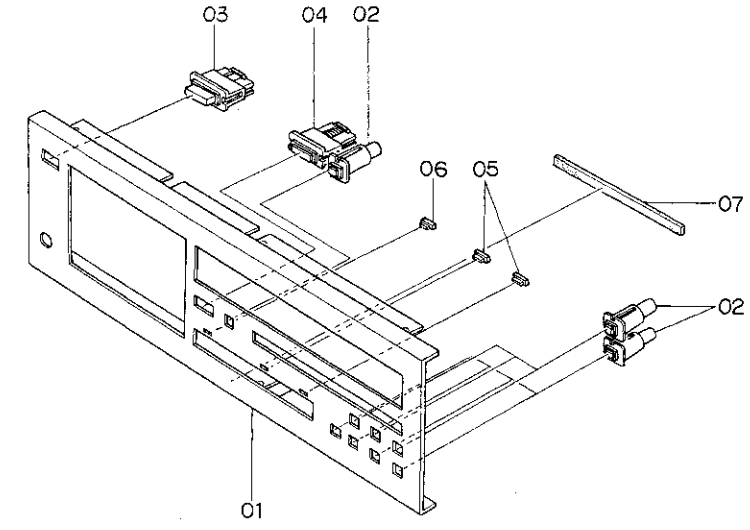

Fig. 9.2

9.3. Synthesis Mechanism Ass'y (A02)

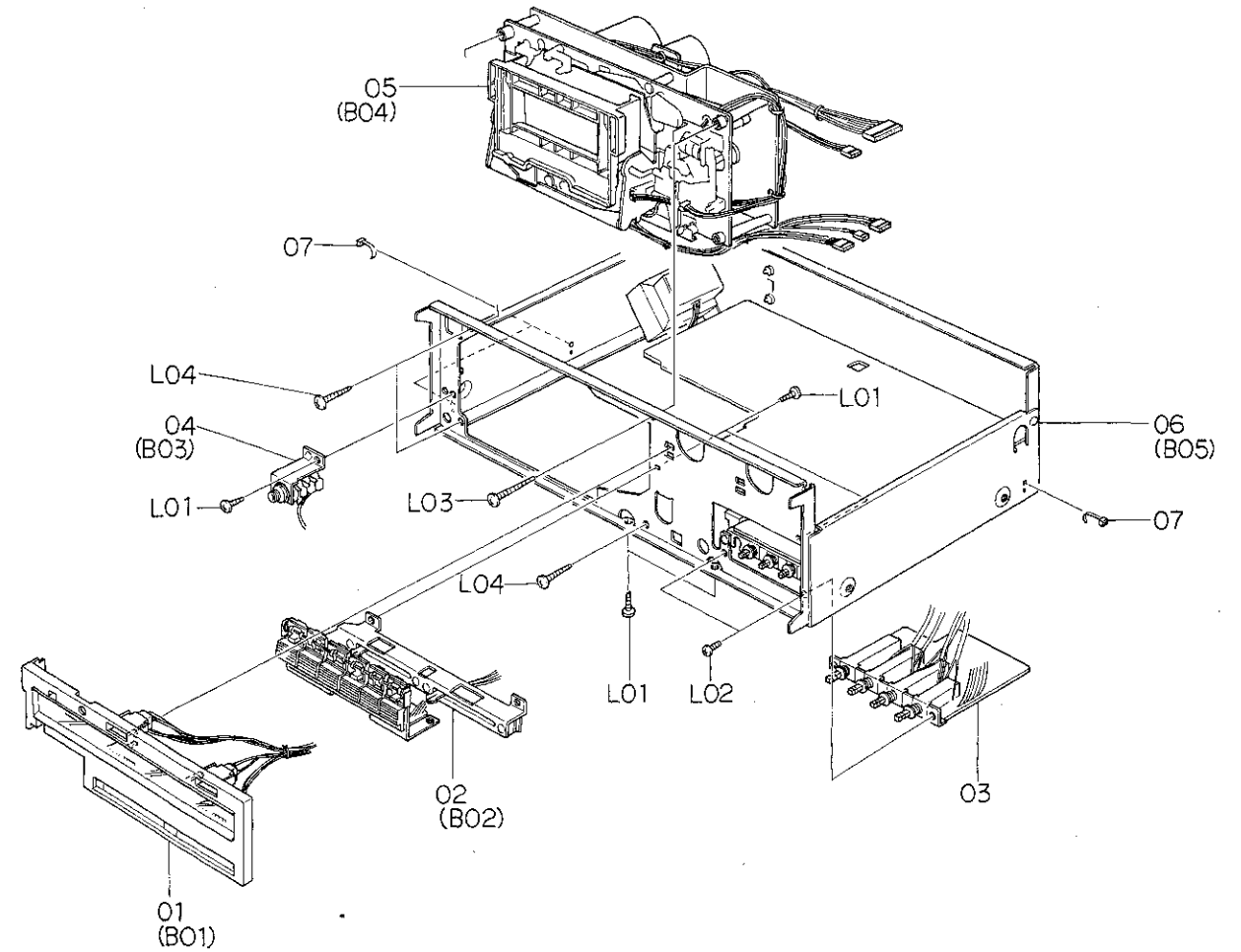

Fig. 9.3

Schematic Ref. No.	Part No.	Description	Q'ty	Schematic Ref. No.	Part No.	Description	Q'ty
		Synthesis			HA03909A	Synthesis Mechanism Ass'y (Australia)	1
01	0H03768A	Top Cover	1		HA03910A	Synthesis Mechanism Ass'y (UK)	1
02	0H03769B	Bottom Cover	1		HA03911A	Synthesis Mechanism Ass'y (Others)	1
03	0J03564A	Leg T-H	4	09	0H03781A	Cushion	6
04	0H03794B	Volume Knob	2	10	0M04101A	Caution Label	2
05	0J04066C	Power Switch Joint Bar	1	L01	0E00858A	BT Screw M4x6 Philips Binding Head (Black Chromate)	4
06	HA03905A	Front Panel Ass'y	1	L02	0E00736A	Washer 4mm (Black Chromate)	4
07	HA03872A	Cassette Case Cover Ass'y	1	L03	0E00857A	BT Screw M3x6 Philips Binding Head	11
08	HA03907A	Synthesis Mechanism Ass'y (U.S.A. & Canada)	1	L04	0E00865A	BT Screw M3x10 Philips Binding Head	4
	HA03906A	Synthesis Mechanism Ass'y (Japan)	1				
	HA03908A	Synthesis Mechanism Ass'y (220V Class 2)	1				

9.4. Meter Escutcheon Ass'y (B01)

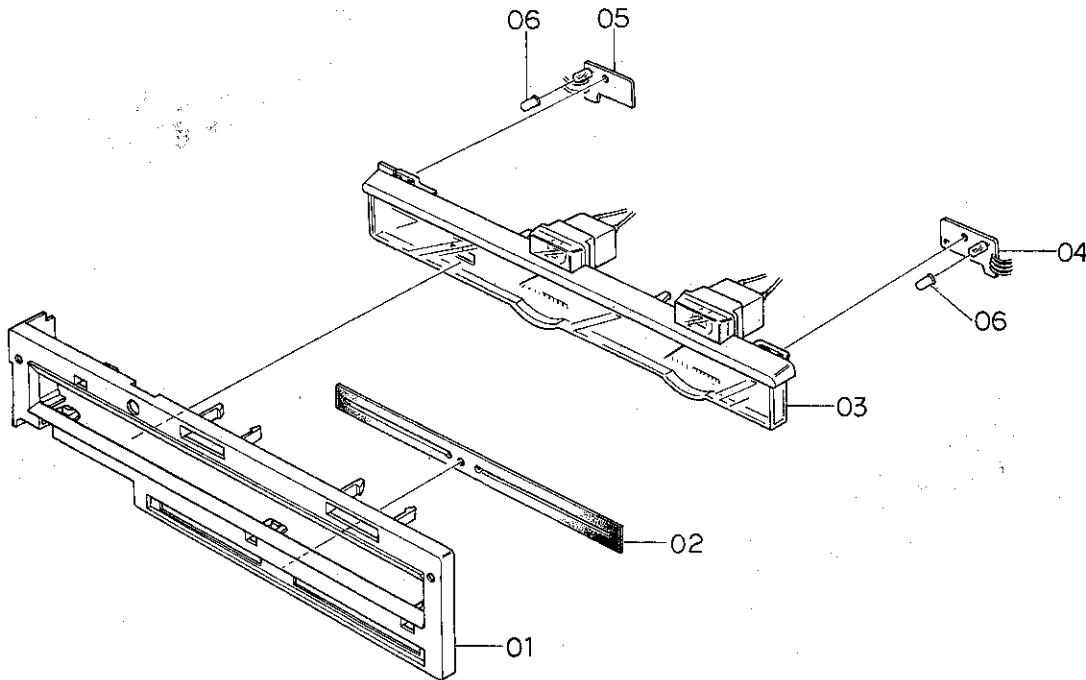

Fig. 9.4

Schematic Ref. No.	Part No.	Description	Q'ty	Schematic Ref. No.	Part No.	Description	Q'ty
A01	HA03905A	Front Panel Ass'y	1	05	CA08135B	Mechanism Ass'y 481	1
01	0H03809A	Front Panel	1	06	JA03641A	Chassis Ass'y (U.S.A. & Canada)	1
02	HA03873A	Push Button Ass'y C	8		JA03640A	Chassis Ass'y (Japan)	1
03	HA03874A	Push Button Ass'y D	1		JA03642A	Chassis Ass'y (220V Class 2)	1
04	HA03875A	Eject Button Ass'y	1		JA03643A	Chassis Ass'y (Australia)	1
05	0H03744A	Green Lens	2		JA03644A	Chassis Ass'y (UK)	1
06	0H03745A	Orange Lens	1		JA03645A	Chassis Ass'y (Others)	1
07	0J04094A	Control Button Pad	1	07	0B08515A	Insu-Lock	18
-	0J04081A	Adhesive Tape 55x6	2	L01	0E00857A	BT Screw M3x6 Philips Binding Head	5
-	0J04082A	Adhesive Tape 30x6	2	L02	0E00502A	Screw M3x5 Philips Pan Head	2
-	0J04098A	Adhesive Tape 70x6	3	L03	0E00878A	BT Screw M4x20 Philips Binding Head	1
A02	HA03907A	Synthesis Mechanism Ass'y (U.S.A. & Canada)	1	L04	0E00867A	BT Screw M4x15 Philips Binding Head	3
	HA03906A	Synthesis Mechanism Ass'y (Japan)	1	B01	HA03851A	Meter Escutcheon Ass'y	1
	HA03908A	Synthesis Mechanism Ass'y (220V Class 2)	1	01	0H03770B	Meter Escutcheon	1
	HA03909A	Synthesis Mechanism Ass'y (Australia)	1	02	0H03786A	Volume Cover	1
	HA03910A	Synthesis Mechanism Ass'y (UK)	1	03	BA04110B	Meter Ass'y	1
	HA03911A	Synthesis Mechanism Ass'y (Others)	1	04	BA04124A	Lamp P.C.B. R Ass'y	1
01	HA03851A	Meter Escutcheon Ass'y	1	05	BA04125A	Lamp P.C.B. L Ass'y	1
02	JA03627A	Control Switch Holder Ass'y	1	06	0H03785A	Filter Cover	2
03	BA04154A	Switch P.C.B. Ass'y	1	-	0H03771B	Aluminum Seal	1
04	JA03616A	Headphone Jack Ass'y	1				

9.5. Control Switch Holder Ass'y (B02)

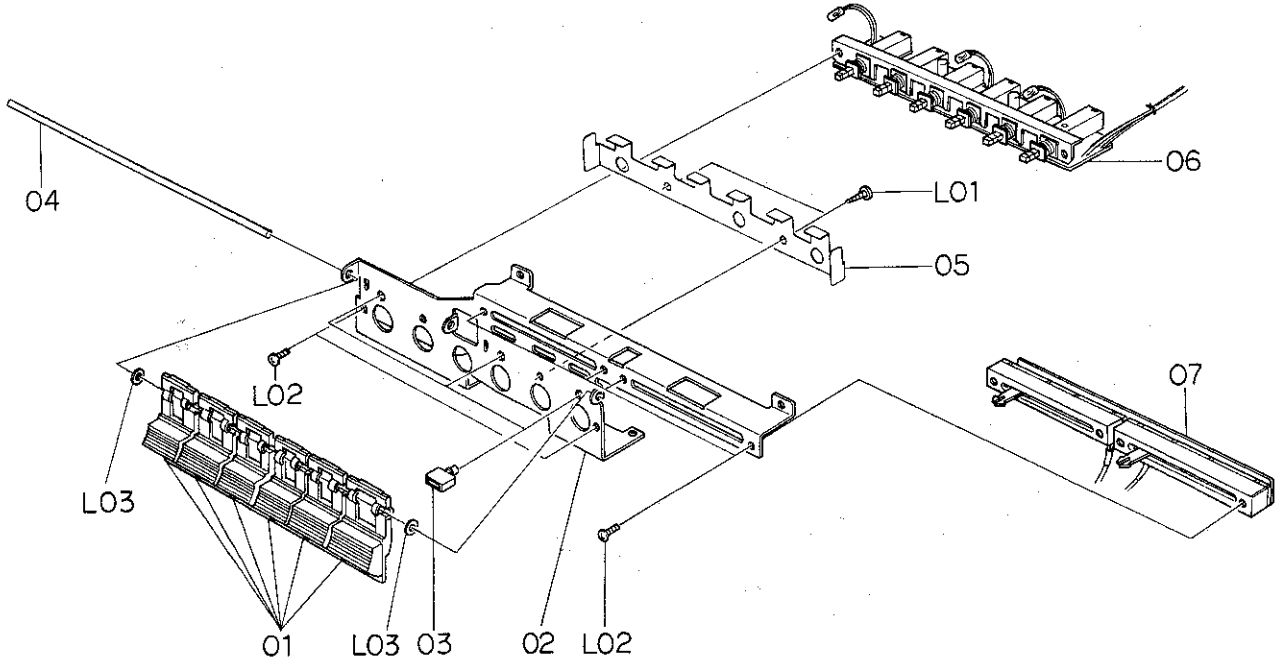

Fig. 9.5

9.6. Headphone Jack Ass'y (B03)

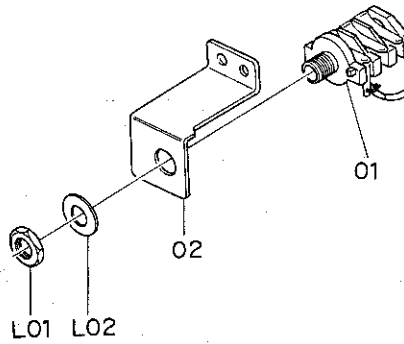

Fig. 9.6

Schematic Ref. No.	Part No.	Description	Q'ty	Schematic Ref. No.	Part No.	Description	Q'ty
B02	JA03627A	Control Switch Holder Ass'y	1	B03	JA03616A	Headphone Jack Ass'y	1
01	0H03793A	Control Button	6	01	0B08511A	Headphone Jack	1
02	0J04071C	Control Switch Holder	1	02	0J04070A	Headphone Jack Holder	1
03	0J04072B	Lamp Cover	3	L01	-	Jack Nut	(1)
04	0J04073A	Control Button Shaft	1	L02	-	Jack Washer	(1)
05	0J04074D	Control Button Spring	1				
06	BA04113A	Control Switch P.C.B. Ass'y	1				
07	BA04114A	Volume P.C.B. Ass'y	1				
L01	0E00857A	BT Screw M3x6 Philips Binding Head	2				
L02	0E00502A	Screw M3x5 Philips Pan Head	6				
L03	0E00117A	Washer 2mm	2				

9.7. Mechanism Ass'y 481 (B04)

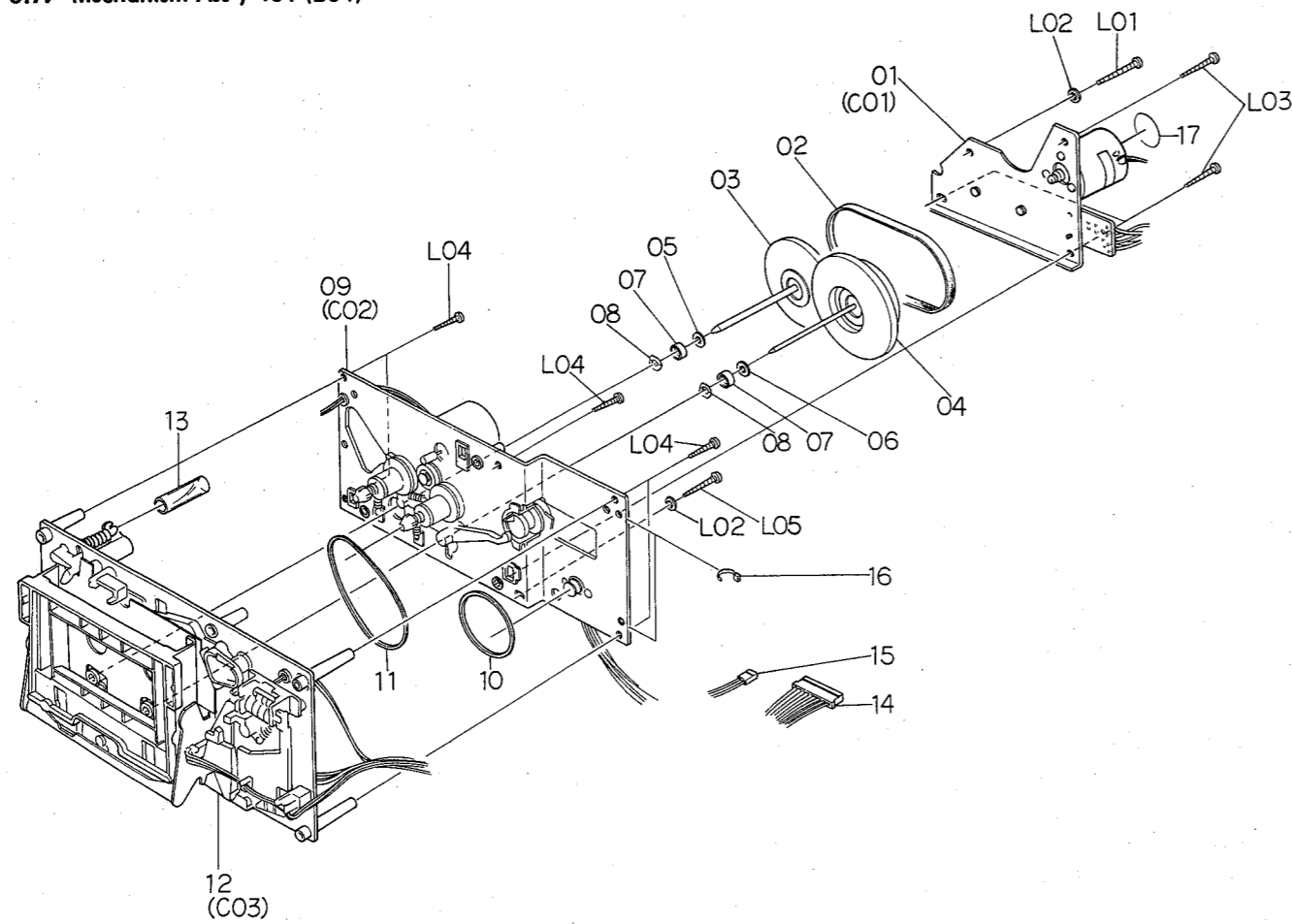

Fig. 9.7

Schematic Ref. No.	Part No.	Description	Q'ty	Schematic Ref. No.	Part No.	Description	Q'ty
B04	CA08135B	Mechanism Ass'y 481 Serial No.: A30605381 -	1	B04	CA08135A	Mechanism Ass'y 481 Serial Nos.: A30601001 - A30605380	1
01	CA08109A	Flywheel Holder Ass'y	1	01	CA08109A	Flywheel Holder Ass'y	1
02	0C08096C	Capstan Belt	1	02	0C08096C	Capstan Belt	1
03	CA08169A	Supply Flywheel B Ass'y	1	03	CA08113A	Supply Flywheel B Ass'y	1
04	CA08107A	Take-up Flywheel B Ass'y	1	04	CA08107A	Take-up Flywheel B Ass'y	1
05	0C08021B	Thrust Washer 3.1mm	1	05	0C08021B	Thrust Washer 3.1mm	1
06	0C08020B	Thrust Washer 2.6mm	1	06	0C08020B	Thrust Washer 2.6mm	1
07	0C08069C	Flange Thrust Cap	2	07	0C08069C	Flange Thrust Cap	2
08	0C08022B	Flange Thrust Spring	2	08	0C08022B	Flange Thrust Spring	2
09	CA08165A	Sub Mechanism Chassis Ass'y	1	09	CA08165A	Sub Mechanism Chassis Ass'y	1
10	0C08098B	Counter Belt B	1	10	0C08098B	Counter Belt B	1
11	0C08099B	Control Motor Belt	1	11	0C08099B	Control Motor Belt	1
12	CA08171A	Main Mechanism Chassis Ass'y	1	12	CA08140A	Main Mechanism Chassis Ass'y	1
13	0C08151A	Lid Arm Spring Tube	1	13	0C08151A	Lid Arm Spring Tube	1
14	0B08671B	12P-H Connector	1	14	0B08671B	12P-H Connector	1
15	0B08672B	3P-H Connector	1	15	0B08672B	3P-H Connector	1
16	0B08515A	Insu-Lock	9	16	0B08515A	Insu-Lock	8
17	0M03902A	Motor Label 730	1	17	0M03902A	Motor Label 730	1
L01	0E00834A	BT Screw M3x30 Philips Pan Head	1	L01	0E00834A	BT Screw M3x30 Philips Pan Head	1
L02	0E00178A	Washer 3mm	2	L02	0E00178A	Washer 3mm	2
L03	0E00833A	BT Screw M3x20 Philips Pan Head	3	L03	0E00833A	BT Screw M3x20 Philips Pan Head	3
L04	0E00883A	BT Screw M3x18 Philips Pan Head	5	L04	0E00883A	BT Screw M3x18 Philips Pan Head	5
L05	0E00835A	BT Screw M3x25 Philips Pan Head	1	L05	0E00835A	BT Screw M3x25 Philips Pan Head	1

9.8. Chassis Ass'y (B05)

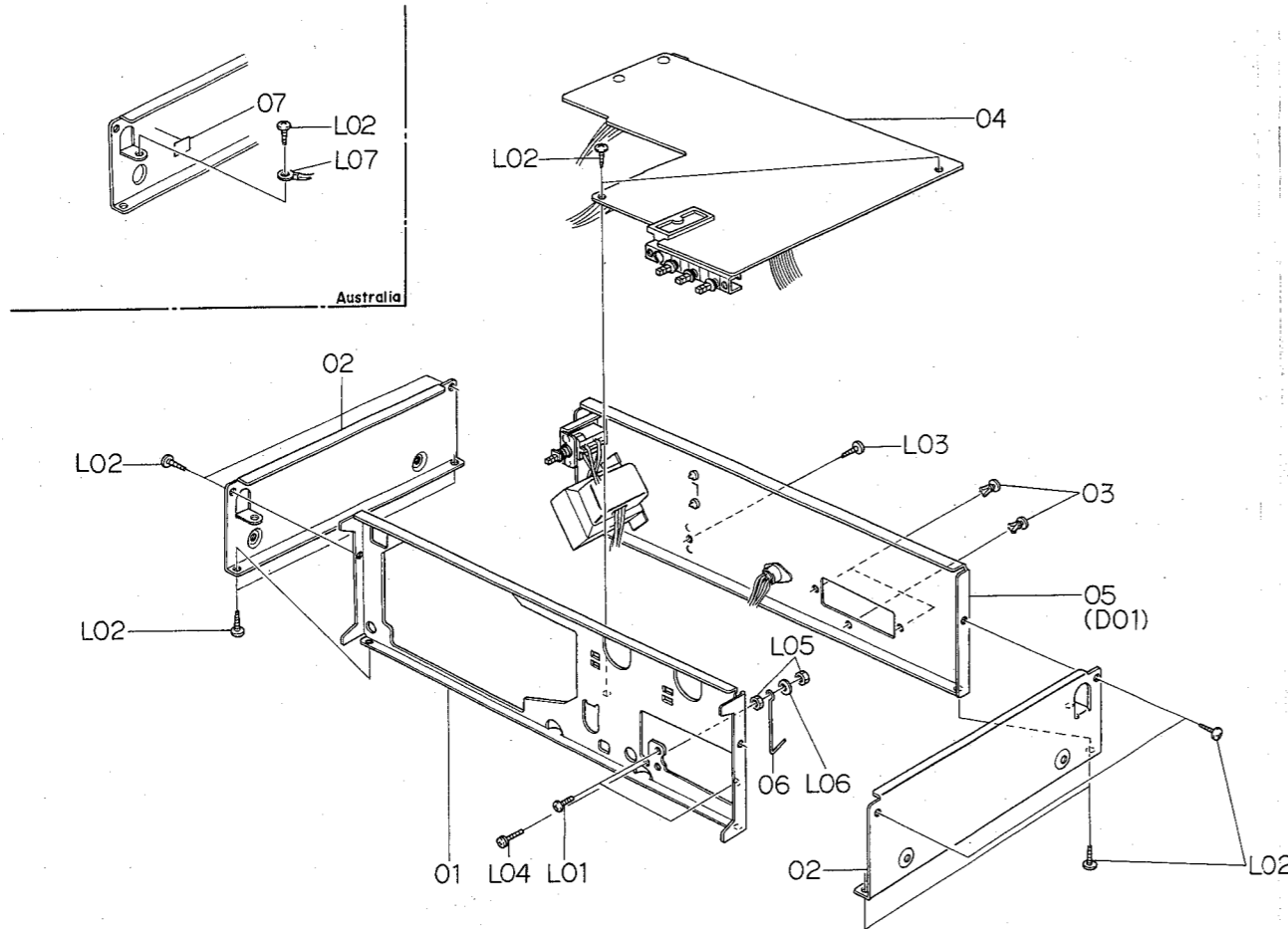

Fig. 9.8

9.9. Flywheel Holder Ass'y (C01)

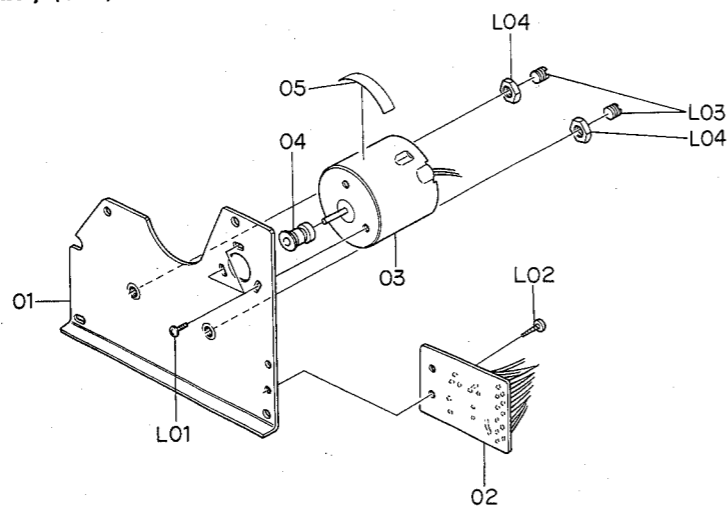

Fig. 9.9

Schematic Ref. No.	Part No.	Description	Q'ty	Schematic Ref. No.	Part No.	Description	Q'ty	
B05	JA03641A	Chassis Ass'y (U.S.A. & Canada)	1		HA03916A	Rear Panel Ass'y (UK)	1	
	JA03640A	Chassis Ass'y (Japan)	1		HA03917A	Rear Panel Ass'y (Others)	1	
	JA03642A	Chassis Ass'y (220V Class 2)	1		06	0C08240A	Contact Wire	1
	JA03643A	Chassis Ass'y (Australia)	1		*07	0M03700A	Earth Mark Label	1
	JA03644A	Chassis Ass'y (UK)	1		L01	0E00502A	Screw M3x5 Philips Pan Head	2
	JA03645A	Chassis Ass'y (Others)	1		*L02	0E00857A	BT Screw M3x6 Philips Binding Head	11
		Serial No.: A30605220 -			L03	0E00860A	BT Screw M3x6 Philips Binding Head (Black Chromate)	1
01	0J04068B	Front Chassis	1	L04	0E00624A	Screw M3x10 Philips Pan Head (2A)	1	
02	0J04069B	Side Chassis	2		L05	0E00178A	Washer 3mm	1
03	0B08720A	Plastic Rivet	3		L06	0E00507A	Nut Hex. M3	2
04	BA04150B	Main P.C.B. Ass'y (U.S.A. & Canada)	1		*L07	0E00037A	Earth Lug B-5	1
	BA04149B	Main P.C.B. Ass'y (Japan)	1					
	BA04151B	Main P.C.B. Ass'y (220V Class 2)	1					
	BA04152B	Main P.C.B. Ass'y (UK & Australia)	1					
	BA04153B	Main P.C.B. Ass'y (Others)	1	C01	CA08109A	Flywheel Holder Ass'y	1	
05	HA03913A	Rear Panel Ass'y (U.S.A. & Canada)	1		01	0C08013I	Flywheel Holder	1
	HA03912A	Rear Panel Ass'y (Japan)	1		02	BA04126A	Control P.C.B. Ass'y	1
	HA03914A	Rear Panel Ass'y (220V Class 2)	1		03	0C08219A	Capstan Motor	1
	HA03915A	Rear Panel Ass'y (Australia)	1		04	0C08212B	Capstan Motor Pulley	1
	HA03916A	Rear Panel Ass'y (UK)	1		05	0M04077A	Motor Seal	1
	HA03917A	Rear Panel Ass'y (Others)	1		L01	0E00226A	Screw M2.6x4 Philips Pan Head	3
06	0C08240A	Contact Wire	1	L02	0E00843A	BT Screw M3x5 Philips Pan Head	1	
* 07	0M03700A	Earth Mark Label	1	L03	0C08068C	Thrust Screw	2	
L01	0E00502A	Screw M3x5 Philips Pan Head	2	L04	0C03857A	Lock Nut	2	
*L02	0E00857A	BT Screw M3x6 Philips Binding Head	11					
L03	0E00860A	BT Screw M3x6 Philips Binding Head (Black Chromate)	1					
L04	0E00624A	Screw M3x10 Philips Pan Head (2A)	1					
L05	0E00178A	Washer 3mm	1					
L06	0E00507A	Nut Hex. M3	2					
*L07	0E00037A	Earth Lug B-5	1					
		*: Depends on the versions.						
B05	JA03641A	Chassis Ass'y (U.S.A. & Canada)	1		JA03641A	Chassis Ass'y (U.S.A. & Canada)	1	
	JA03640A	Chassis Ass'y (Japan)	1		JA03640A	Chassis Ass'y (Japan)	1	
	JA03642A	Chassis Ass'y (220V Class 2)	1		JA03642A	Chassis Ass'y (220V Class 2)	1	
	JA03643A	Chassis Ass'y (Australia)	1		JA03643A	Chassis Ass'y (Australia)	1	
	JA03644A	Chassis Ass'y (UK)	1		JA03644A	Chassis Ass'y (UK)	1	
	JA03645A	Chassis Ass'y (Others)	1		JA03645A	Chassis Ass'y (Others)	1	
		Serial Nos: A30601001 - A30605219				Serial Nos: A30601001 - A30605219		
01	0J04068B	Front Chassis	1	01	0J04068B	Front Chassis	1	
02	0J04069B	Side Chassis	2		02	0J04069B	Side Chassis	2
03	0B08539A	Plastic Rivet	3		03	0B08539A	Plastic Rivet	3
04	BA04150A	Main P.C.B. Ass'y (U.S.A. & Canada)	1		04	BA04150A	Main P.C.B. Ass'y (U.S.A. & Canada)	1
	BA04149A	Main P.C.B. Ass'y (Japan)	1			BA04149A	Main P.C.B. Ass'y (Japan)	1
	BA04151A	Main P.C.B. Ass'y (220V Class 2)	1			BA04151A	Main P.C.B. Ass'y (220V Class 2)	1
	BA04152A	Main P.C.B. Ass'y (UK & Australia)	1			BA04152A	Main P.C.B. Ass'y (UK & Australia)	1
	BA04153A	Main P.C.B. Ass'y (Others)	1	05	BA04153A	Main P.C.B. Ass'y (Others)	1	
05	HA03913A	Rear Panel Ass'y (U.S.A. & Canada)	1		HA03913A	Rear Panel Ass'y (U.S.A. & Canada)	1	
	HA03912A	Rear Panel Ass'y (Japan)	1		HA03912A	Rear Panel Ass'y (Japan)	1	
	HA03914A	Rear Panel Ass'y (220V Class 2)	1		HA03914A	Rear Panel Ass'y (220V Class 2)	1	
	HA03915A	Rear Panel Ass'y (Australia)	1		HA03915A	Rear Panel Ass'y (Australia)	1	

9.10. Sub Mechanism Chassis Ass'y (C02)

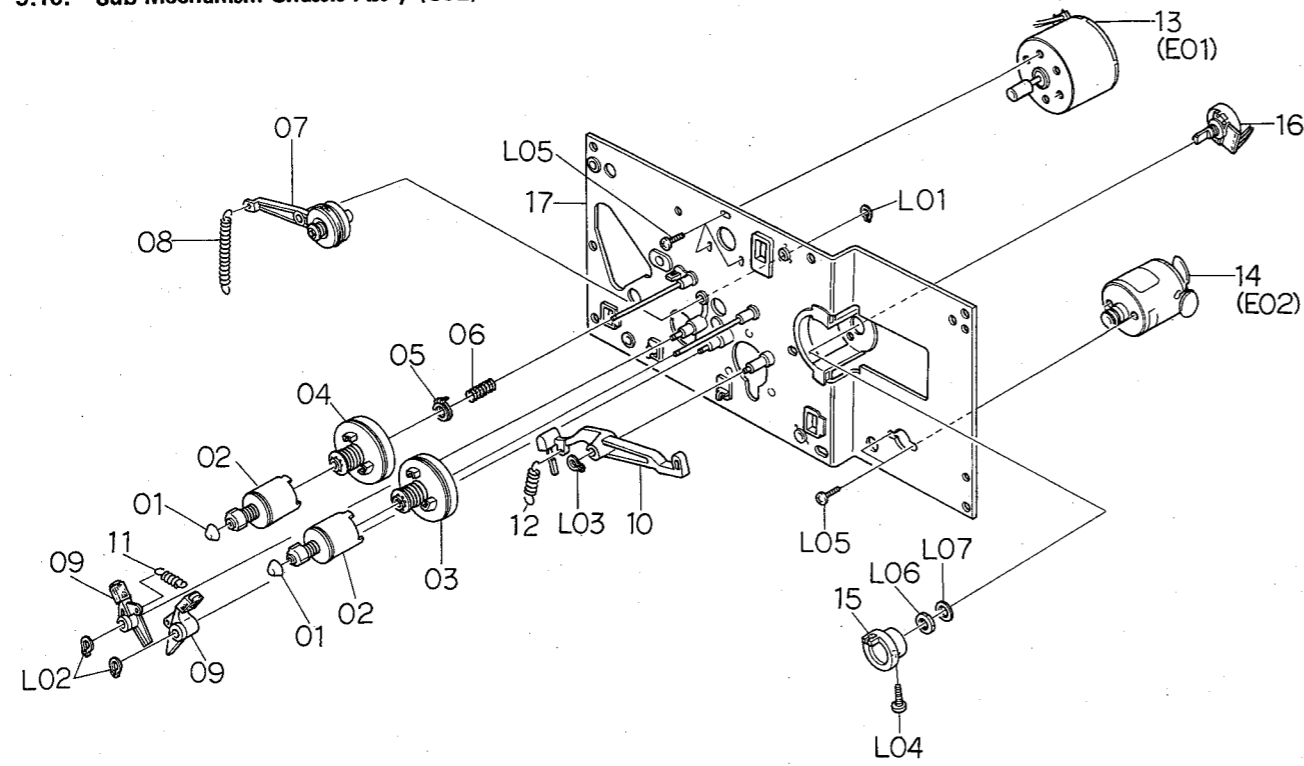

Fig. 9.10

Schematic Ref. No.	Part No.	Description	Q'ty
C02	CA08165A	Sub Mechanism Chassis Ass'y	1
01	0C08039B	Reel Hub Head	2
02	CA08038B	Reel Hub B Ass'y	2
03	CA08037A	Reel Hub Take-up Ass'y	1
04	CA08064A	Reel Hub Supply Ass'y	1
05	CA08039A	Back Tension Ass'y	1
06	0C08178A	Back Tension Spring	1
07	CA08040A	Idler Ass'y	1
08	0C08127B	Idler Arm Spring	1
09	CA08042A	Brake Arm Ass'y	2
10	0C08030C	Brake Drive Arm	1
11	0C08029A	Brake Arm Spring	1
12	0C08128A	Brake Drive Arm Spring	1
13	CA08117B	Reel Motor Ass'y	1
14	CA08124A	Control Motor Ass'y	1
15	0C08053B	Volume Coupler	1
16	0B07240A	Volume Control 10kΩ (B)	1
17	CA08041A	Sub Chassis Ass'y	1
L01	0E00842A	Stopper Ring 2mm	1
L02	0E00837A	Stopper Ring 3mm	2
L03	0E00838A	Stopper Ring 4mm	1
L04	0E00859A	BT Screw M2.6x6 Philips Binding Head	1
L05	0E00226A	Screw M2.6x4 Philips Pan Head	5
L06	-	Volume Nut	(1)
L07	-	Volume Washer	(1)

Schematic Ref. No.	Part No.	Description	Q'ty
C03	CA08171A	Main Mechanism Chassis Ass'y Serial No.: A30605381 -	1
01	CA08141A	Cassette Case Holder L Ass'y	1
02	CA08022A	Cassette Case Holder R Ass'y	1
03	CA08111A	Cassette Case Ass'y	1
04	0C08019I	Cover Plate	1
05	0M03977A	Cassette Viewer Label	1
06	CA08136A	Head Mount Base Ass'y	1
07	0C08121A	Supply Pressure Roller Spring	1
08	CA08053B	Supply Pressure Roller Ass'y	1
09	0C08122B	Supply Pressure Roller Thrust Spring	1
10	CA08079B	Take-up Pressure Roller Ass'y	1
11	0C08183B	Take-up Pressure Roller Thrust Spring	1
12	0C08182A	Pressure Roller Drive Bar	1
13	CA08121A	Head Base Ass'y C	1
14	0C08086B	Head Base Roller	3
15	0C08050B	Record Sensor	1
16	0C08051E	Cassette Hold Arm	1
17	0C08120A	Cassette Hold Arm Spring	1
18	CA08027A	Head Base Drive Arm Ass'y	1
19	0C08143C	Head Base Drive Arm Spring	1
20	CA08025A	Record Arm Ass'y	1
21	0C08038D	Record Trigger	1
22	0C08112A	Flip-Flop Spring	1
23	CA08026A	Pressure Roller Drive Arm Ass'y	1
24	0C08071D	Counter Reset Arm	1
25	0C08124B	Eject Linkage Wire	1
26	0C08057D	Eject Arm	1
27	0C08078B	Arm Shaft	1
28	CA08119A	Auto Shutt-off Ass'y	1
29	CA08020A	Counter Ass'y	1
30	0C08097B	Counter Belt A	1
31	0C08067C	Eject Stopper	1
32	0C08134C	Eject Stopper Spring	1
33	0C08119A	Record Protector	1
34	0C08194C	Damper Lock Arm	1
35	0C08153A	Damper Arm Spring Tube	1
36	CA08030A	Pneumatic Damper Ass'y	1
37	CA08023A	Supply Capstan Flange Ass'y	1
38	CA08024A	Take-up Capstan Flange Ass'y	1
39	0C08186A	Cam Drive Gear	1
40	0C08029H	Control Cam	1
41	0C08152A	Counter-Load Arm Spring Tube	1
42	0C08117A	Counter-Load Arm Spring	1
43	CA08028A	Counter-Load Arm Ass'y	1
44	0C08123B	Record Switch Linkage Wire	1
45	0C08037E	Record Arm B	1
46	0C08116A	Record Arm Spring	2
47	CA08072A	Main Chassis Ass'y	1
48	0C08225A	Shield Plate	1
49	0C08250A	Supply Pressure Roller Spring B	1
L01	0E00837A	Stopper Ring 3mm	13
L02	0E00832A	BT Screw M3x14 Philips Pan Head	2
L03	0E00834A	BT Screw M3x30 Philips Pan Head	2
L04	0E00831A	BT Screw M3x10 Philips Pan Head	4
L05	0E00254A	Washer 3.1mm Plastics	2

9.11. Main Mechanism Chassis Ass'y (C03)

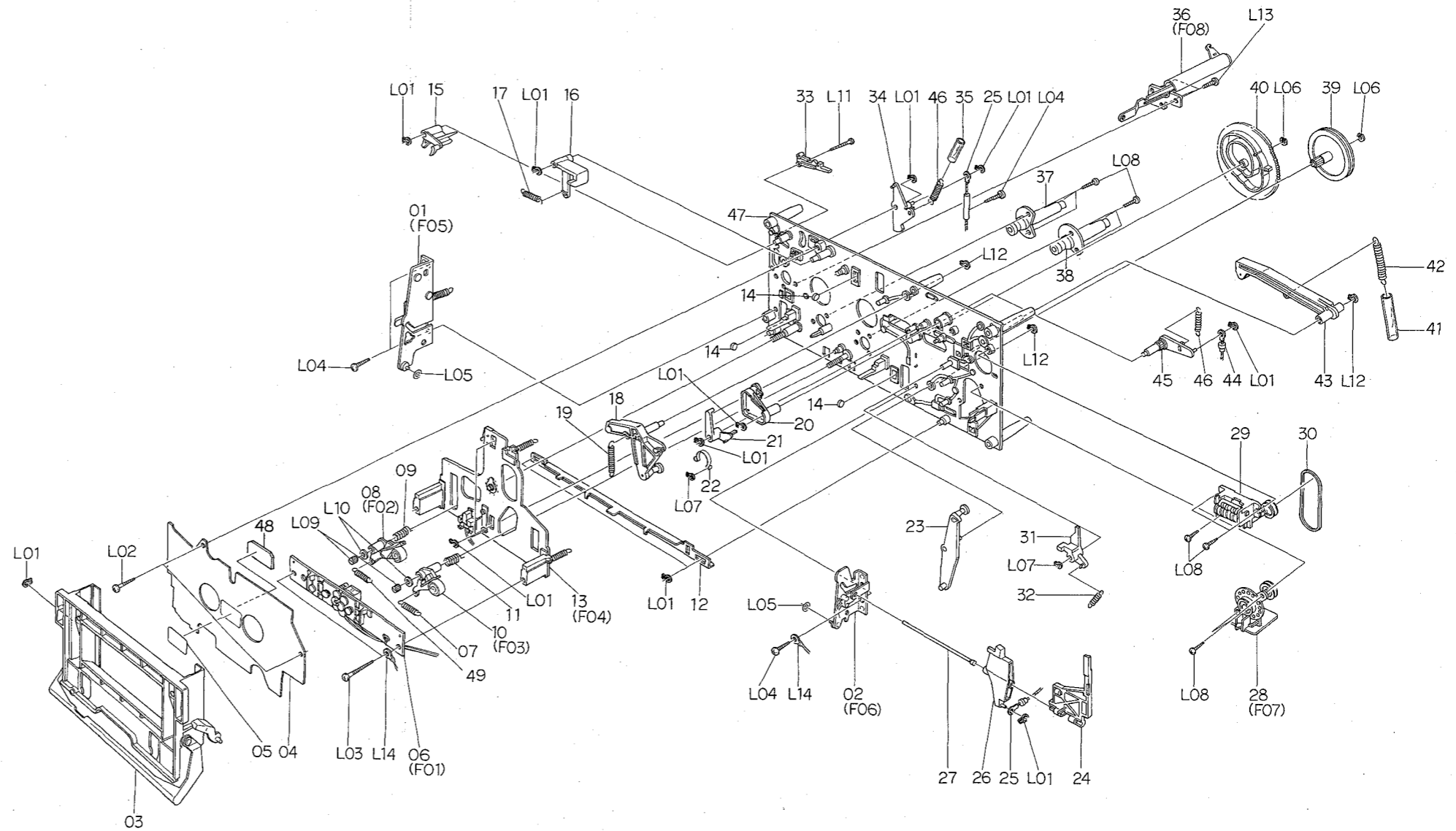

Fig. 9.11.1 Serial No.: A30605381 -

Schematic Ref. No.	Part No.	Description	Q'ty
L06	0E00222A	E-Ring 2mm	2
L07	0E00839A	Stopper Ring 2.5mm	2
L08	0E00876A	BT Screw M2.6x8 Philips Pan Head	11
L09	0C08060B	Height Adjustment Nut	2
L10	0E00142A	Washer 2.6mm	2
L11	0E00879A	BT Screw M2x15 Philips Pan Head	1
L12	0E00838A	Stopper Ring 4mm	3
L13	0E00846A	BT Screw M3x8 Philips Pan Head	3
L14	0E00895A	Earth Lug 3mm	2

Schematic Ref. No.	Part No.	Description	Q'ty
C03	CA08140A	Main Mechanism Chassis Ass'y Serial Nos.: A30601001 - A30605380	1
01	CA08141A	Cassette Case Holder L Ass'y	1
02	CA08022A	Cassette Case Holder R Ass'y	1
03	CA08111A	Cassette Case Ass'y	1
04	OC08019I	Cover Plate	1
05	0M03977A	Cassette Viewer Label	1
06	CA08136A	Head Mount Base Ass'y	1
07	OC08121A	Supply Pressure Roller Spring	2
08	CA08053B	Supply Pressure Roller Ass'y	1
09	OC08122B	Supply Pressure Roller Thrust Spring	1
10	CA08079B	Take-up Pressure Roller Ass'y	1
11	OC08183B	Take-up Pressure Roller Thrust Spring	1
12	OC08182A	Pressure Roller Drive Bar	1
13	CA08121A	Head Base Ass'y C	1
14	OC08086B	Head Base Roller	3
15	OC08050B	Record Sensor	1
16	OC08051E	Cassette Hold Arm	1
17	OC08120A	Cassette Hold Arm Spring	1
18	CA08027A	Head Base Drive Arm Ass'y	1
19	OC08143C	Head Base Drive Arm Spring	1
20	CA08025A	Record Arm Ass'y	1
21	OC08038D	Record Trigger	1
22	OC08112A	Flip-Flop Spring	1
23	CA08026A	Pressure Roller Drive Arm Ass'y	1
24	OC08071D	Counter Reset Arm	1
25	OC08124B	Eject Linkage Wire	1
26	OC08057D	Eject Arm	1
27	OC08078B	Arm Shaft	1
28	CA08119A	Auto Shut-off Ass'y	1
29	CA08020A	Counter Ass'y	1
30	OC08097B	Counter Belt A	1
31	OC08067C	Eject Stopper	1
32	OC08134C	Eject Stopper Spring	1
33	OC08119A	Record Protector	1
34	OC08194C	Damper Lock Arm	1
35	OC08153A	Damper Arm Spring Tube	1
36	CA08030A	Pneumatic Damper Ass'y	1
37	CA08023A	Supply Capstan Flange Ass'y	1
38	CA08024A	Take-up Capstan Flange Ass'y	1
39	OC08186A	Cam Drive Gear	1
40	OC08029H	Control Cam	1
41	OC08152A	Counter-Load Arm Spring Tube	1
42	OC08117A	Counter-Load Arm Spring	1
43	CA08028A	Counter-Load Arm Ass'y	1
44	OC08123B	Record Switch Linkage Wire	1
45	OC08037E	Record Arm B	1
46	OC08116A	Record Arm Spring	2
47	CA08072A	Main Chassis Ass'y	1
48	OC08225A	Shield Plate	1
L01	0E00837A	Stopper Ring 3mm	13
L02	0E00832A	BT Screw M3x14 Philips Pan Head	2
L03	0E00834A	BT Screw M3x30 Philips Pan Head	2
L04	0E00831A	BT Screw M3x10 Philips Pan Head	4
L05	0E00254A	Washer 3.1mm Plastics	2
L06	0E00222A	E-Ring 2mm	2

Schematic Ref. No.	Part No.	Description	Q'ty
L07	0E00839A	Stopper Ring 2.5mm	2
L08	0E00876A	BT Screw M2.6x8 Philips Pan Head	11
L09	OC08060B	Height Adjustment Nut	2
L10	0E00142A	Washer 2.6mm	2
L11	0E00879A	BT Screw M2x15 Philips Pan Head	1
L12	0E00838A	Stopper Ring 4mm	3
L13	0E00846A	BT Screw M3x8 Philips Pan Head	3
L14	0E00895A	Earth Lug 3mm	2

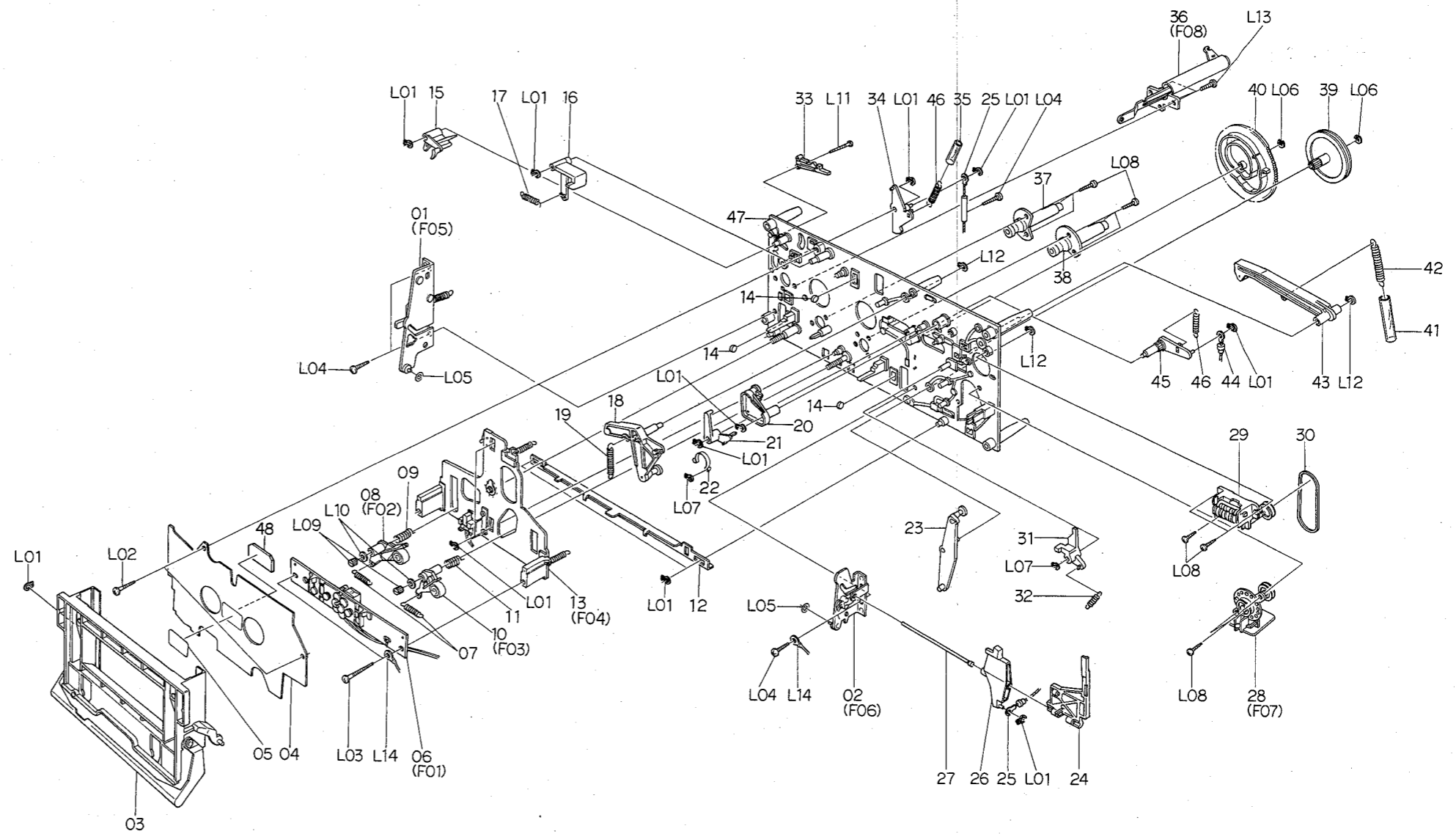

Fig. 9.11.2 Serial Nos.: A30601001 - A30605380

9.12. Rear Panel Ass'y (D01)

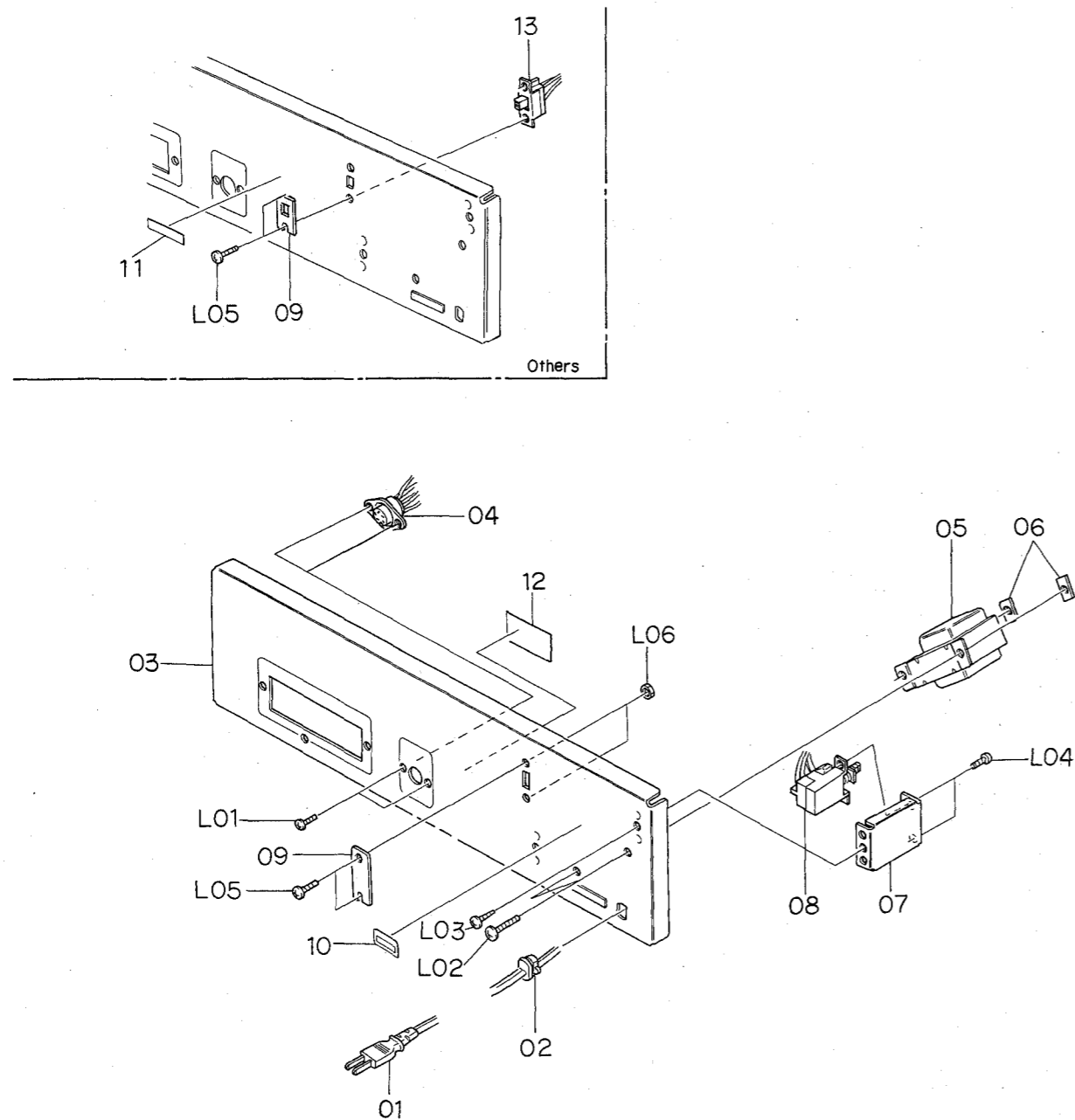

Fig. 9.12

Schematic Ref. No.	Part No.	Description	Q'ty	Schematic Ref. No.	Part No.	Description	Q'ty				
D01	HA03913A	Rear Panel Ass'y (U.S.A. & Canada)	1	L06	0E00507A	Nut Hex. M3	2				
	HA03912A	Rear Panel Ass'y (Japan)	1	-	0J03644A	Chobert Rivet	2				
	HA03914A	Rear Panel Ass'y (220V Class 2)	1	*: Depends on the versions.							
	HA03915A	Rear Panel Ass'y (Australia)	1	E01	CA08117B	Reel Motor Ass'y	1				
	HA03916A	Rear Panel Ass'y (UK)	1								
	HA03917A	Rear Panel Ass'y (Others)	1								
01	0B08533A	Power Cord (U.S.A., Canada & Others)	1	01	0C08218A	Reel Motor	1				
	0B08219B	Power Cord (Japan)	1	02	0C08063F	Reel Motor Pulley	1				
	0B08093U	Power Cord (220V Class 2)	1	E02	CA08124A	Control Motor Ass'y	1				
	0B08666A	Power Cord (Australia)	1								
	0B08348A	Power Cord (UK)	1								
02	0B08037U	Cord Bushing C (U.S.A., Canada, Japan, 220V Class 2 & Others)	1	01	0C08137A	Control Motor	1				
	0B08719A	Cord Bushing (Australia)	1	02	0C08064A	Control Motor Pulley	1				
	0B08351A	Cord Bushing 4K-4 (UK)	1	03	0B09292A	Ceramic Capacitor 0.1μ 50V Z	2				
	0H03807B	Rear Panel	1	04	0M03985A	Control Motor Label	1				
	0B08687A	6P DIN Socket	1	05	0M03988A	Motor Seal B	1				
03	0B06623A	Power Transformer (U.S.A. & Canada)	1	F01	CA08136A	Head Mount Base Ass'y	1				
	0B06622A	Power Transformer (Japan)	1								
	0B06624A	Power Transformer (220V Class 2, Australia & UK)	1								
	0B06625A	Power Transformer (Others)	1								
	0C01162B	Bolt Receptacle Plate	2								
04	0J04076A	Power Switch Holder	1					01	0C08028C	Head Height Adjustment Gear	2
	0B07299A	Power Switch (U.S.A. & Canada)	1					02	0C08027E	Head Height Adjustment Screw	4
	0B07301A	Power Switch (Japan)	1					03	0C08026D	Azimuth Alignment Screw	2
	0B07252A	Power Switch (220V Class 2, Australia, UK & Others)	1	04	0C08161B	Spring Stopper	2				
	0J03663C	Switch Cover (U.S.A., Canada, Japan, 220V Class 2, UK & Australia)	1	05	0C08131C	Head Plate Spring	2				
05	0M03946A	Voltage Selector Lock Plate C (Others)	1	06	CA08083C	Head Mount Base Sub Ass'y	1				
	0M03551B	Pass Label	1	07	CA08137A	P-8L Playback Head Ass'y	1				
	0M03794A	Voltage Label 100V (Japan)	1	08	CA08138A	R-8L Record Head Ass'y	1				
	0M03796A	Voltage Label 220V (220V Class 2)	1	F02	CA08053B	Supply Pressure Roller Ass'y	1				
	0M03797A	Voltage Label 240V (UK & Australia)	1								
0M03955A	Voltage Label 120V/220-240V (Others)	1									
0M04097B	Fuse Caution Label (U.S.A. & Canada)	1									
0B07092U	Voltage Selector (Others)	1									
0M03844B	Power Cord Label (UK)	1	01					0C08164G	Pressure Roller	1	
0F01071A	Free-up Belt	1	02					0C08189B	Supply Tape Guide	1	
0M04055A	SDNF Label (220V Class 2)	1	03					CA08061A	Supply Pressure Roller Arm Ass'y	1	
0M03865A	SEV Label (220V Class 2)	1	L01	0E00042A	E-Ring 1.5mm	1					
0M04069B	Serial Number Plate	1	L02	0C08024A	Washer 2mm	2					
0M03798A	Nakamichi Label (Japan)	1	L03	0E00788A	BT Screw M2x8 Philips Pan Head	1					
L01	0E00714A	Screw M2.6x6 Philips Binding Head (Bronze)	2	F03	CA08079B	Take-up Pressure Roller Ass'y Serial No.: A30604799 -	1				
L02	0E00756A	Screw M4x8 Philips Binding Head (Bronze)	2								
L03	0E00860A	BT Screw M3x6 Philips Binding Head (Black Chromate)	1								
L04	0E00502A	Screw M3x5 Philips Pan Head	2								
L05	0E00593A	Screw M3x6 Philips Binding Head (Bronze)	2								
01	0C08164G	Pressure Roller	1								
02	0C08181B	Take-up Tape Guide	1								
03	CA08073B	Take-up Pressure Roller Arm Ass'y	1								
L01	0E00042A	E-Ring 1.5mm	1	F03	CA08079A	Take-up Pressure Roller Ass'y Serial Nos.: A30601001 - A30604798	1				
L02	0C08024A	Washer 2mm	2								
L03	0E00788A	BT Screw M2x8 Philips Pan Head	1								
01	0C08164G	Pressure Roller	1								
02	0C08181B	Take-up Tape Guide	1								
03	CA08073B	Take-up Pressure Roller Arm Ass'y	1								
L01	0E00042A	E-Ring 1.5mm	1								
L02	0C08024A	Washer 2mm	2								
L03	0E00788A	BT Screw M2x8 Philips Pan Head	1								

9.13. Reel Motor Ass'y (E01)

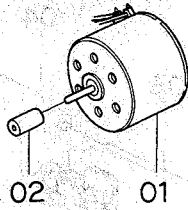

Fig. 9.13

9.14. Control Motor Ass'y (E02)

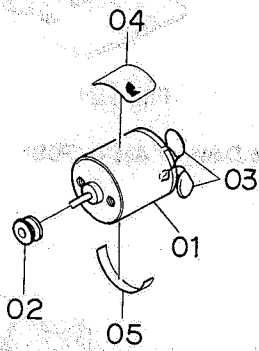

Fig. 9.14

9.15. Head Mount Base Ass'y (F01)

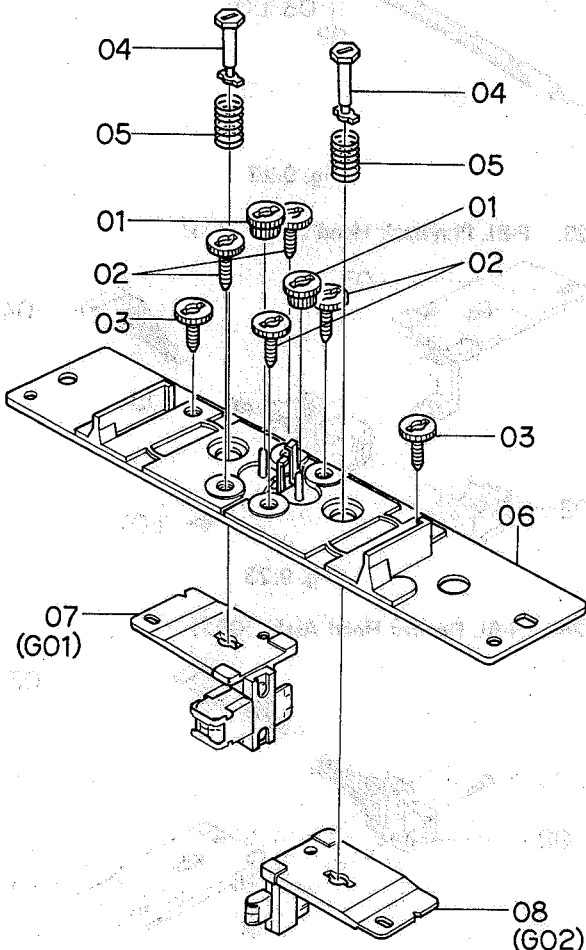

Fig. 9.15

9.16. Supply Pressure Roller Ass'y (F02)

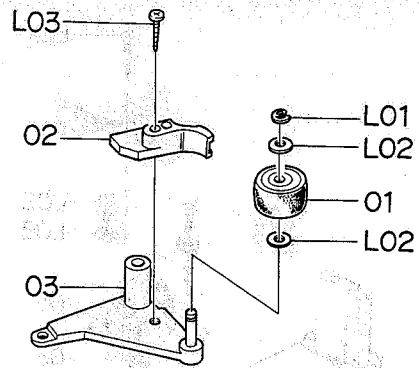

Fig. 9.16

9.17. Take-up Pressure Roller Ass'y (F03)

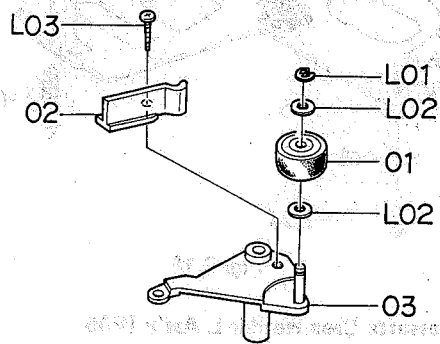

Fig. 9.17

9.18. Head Base Ass'y C (F04)

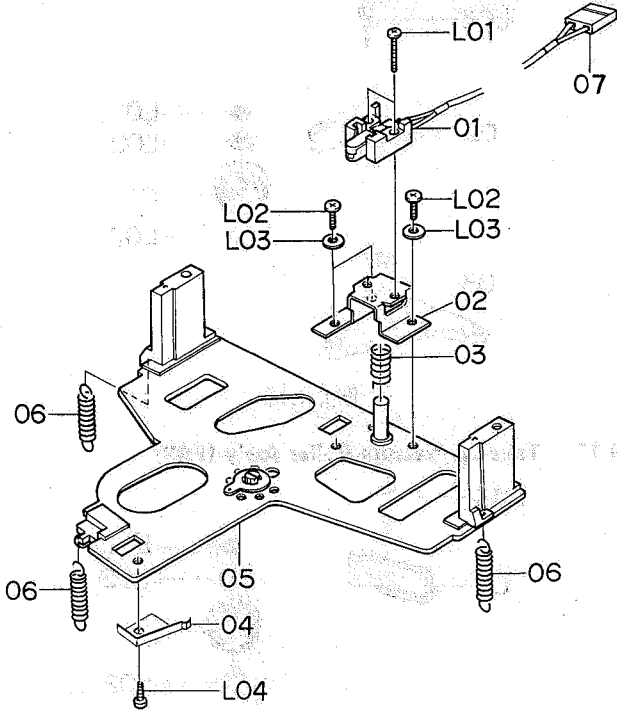

Fig. 9.18

9.19. Cassette Case Holder L Ass'y (F05)

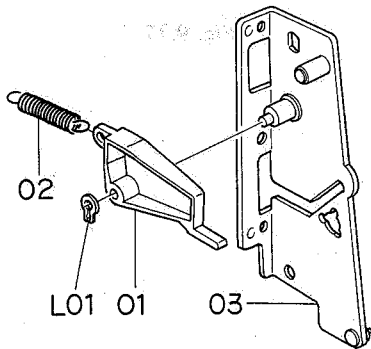

Fig. 9.19

9.20. Cassette Case Holder R Ass'y (F06)

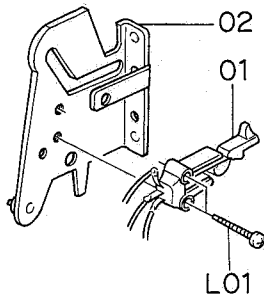

Fig. 9.20

9.21. Auto Shut-off Ass'y (F07)

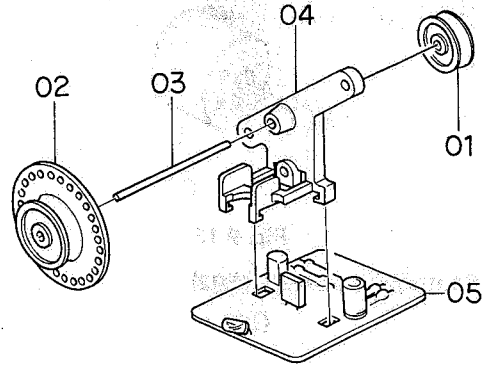

Fig. 9.21

9.22. Pneumatic Damper Ass'y (F08)

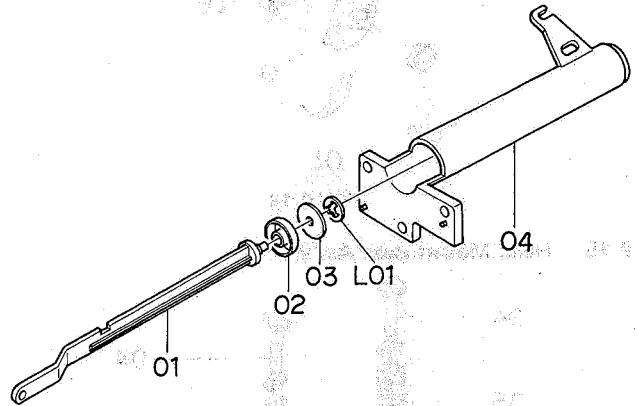

Fig. 9.22

9.23. P-8L Playback Head Ass'y (G01)

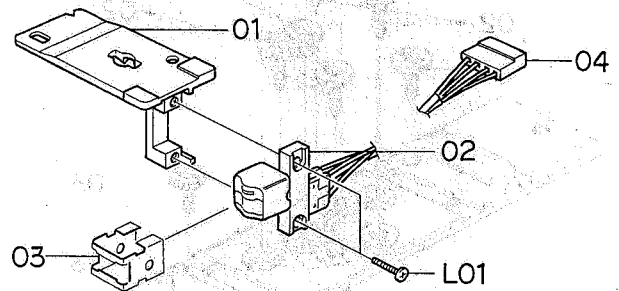

Fig. 9.23

9.24. R-8L Record Head Ass'y (G02)

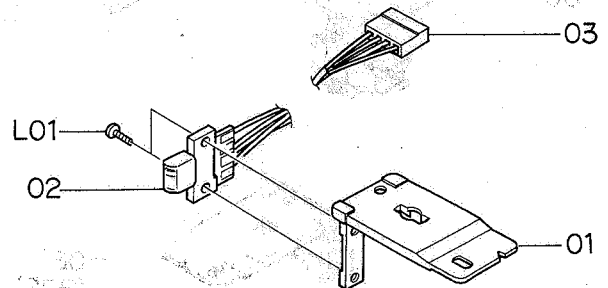

Fig. 9.24

Schematic Ref. No.	Part No.	Description	Q'ty
F04	CA08121A	Head Base Ass'y C	1
01	GA02017A	E-8L Erase Head	1
02	0C08158D	EH Hold Plate	1
03	0C08166A	EH Hold Plate Spring	1
04	0C08174C	Cassette Hold Spring	1
05	CA08003P	Head Base Ass'y	1
06	0C08175A	Head Base L Spring	3
07	0B08679D	2P-H Connector	1
L01	0E00889A	Screw M1.7x8 Philips Pan Head	2
L02	0E00909A	Screw M2x6 Philips Pan Head	3
L03	0E00117A	Washer 2mm	3
L04	0E00853A	BT Screw M2x3 Philips Pan Head	1
F05	CA08141A	Cassette Case Holder L Ass'y	1
01	0C08073C	Lid Arm A	1
02	0C08114A	Lid Arm Spring	1
03	CA08090F	Cassette Case Holder L Sub Ass'y	1
L01	0E00837A	Stopper Ring 3mm	1
F06	CA08022A	Cassette Case Holder R Ass'y	1
01	0C08133A	Eject Sensor	1
02	CA08044A	Cassette Case Holder R Sub Ass'y	1
L01	0E00840A	BT Screw M2x8 Philips Pan Head	2
F07	CA08119A	Auto Shut-off Ass'y	1
01	0C08047A	Shut-off Pulley A	1
02	0C08206B	Shut-off Pulley B	1
03	0C08088B	Shut-off Pulley Shaft	1
04	0C08207B	Shut-off Pulley Holder	1
05	BA04128A	Shut-off P.C.B. Ass'y	1
F08	CA08030A	Pneumatic Damper Ass'y	1
01	0C08058C	Damper Piston	1
02	0C08102B	Damper Ring	1
03	0C08010C	Damper Plate	1
04	0C08059E	Sylinder	1
L01	0E00874A	Stopper Ring CS 2mm	1
G01	CA08137A	P-8L Playback Head Ass'y	1
01	0C08160F	Head Plate	1
02	GA02034A	P-8L Playback Head	1
03	0C08169D	Pad Lifter 54	1
04	0B08704C	PH Connector	1
L01	0E00886A	Screw M1.7x6.5 Philips Pan Head	2
G02	CA08138A	R-8L Record Head Ass'y	1
01	0C08159G	Head Plate	1
02	GA01050A	R-8L Record Head	1
03	0B08705B	RH Connector	1
L01	0E00887A	Screw M1.7x4 Philips Pan Head	2

10. OVERALL TIMING CHART

Mode	PLAYBACK			RECORD					
	Control Button	Stop	Play	Stop	Rec	Rec/Play	Rec/Pause	Rec/Play	Stop
Tape			470ms	120ms		640ms	130ms	220ms	130ms
			300ms	180ms		740ms	160ms	120ms	160ms
Output									
			300ms			560ms			
Bias									
						560ms			

Fig. 10

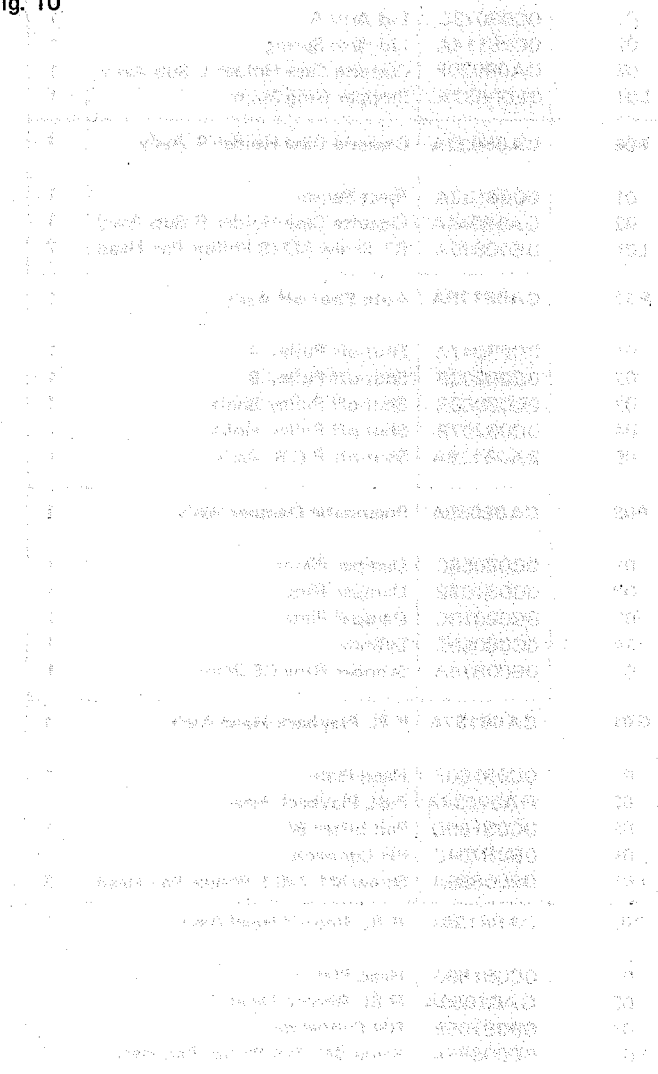

11. EQ. AMP. FREQUENCY RESPONSE

11.1. Playback Frequency Response

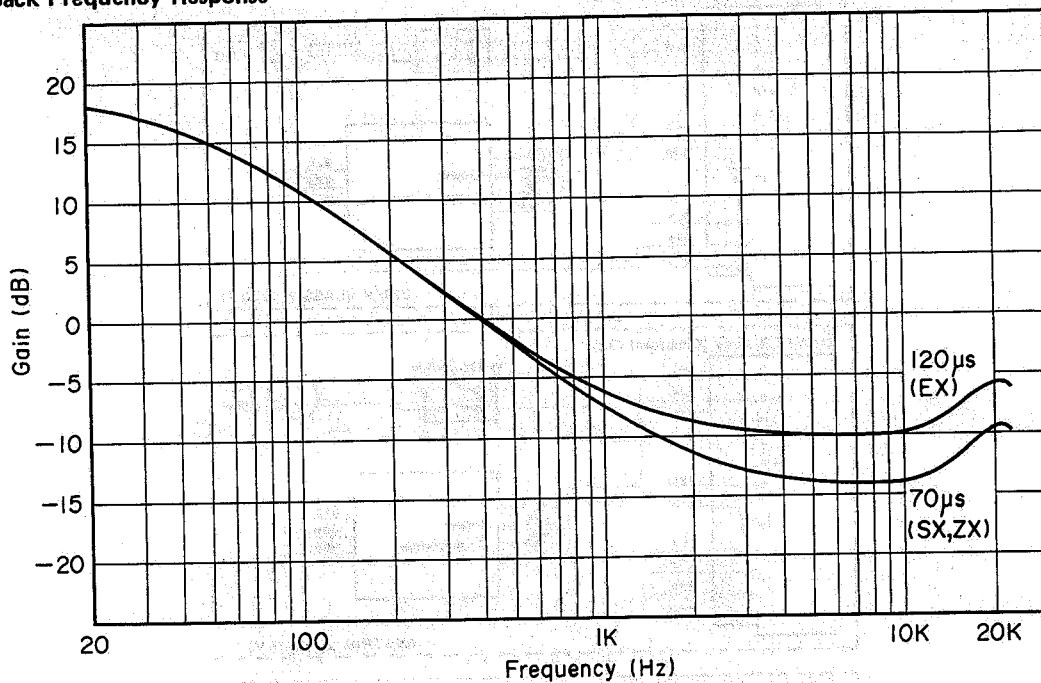

Fig. 11.1

11.2. Record Current Frequency Response

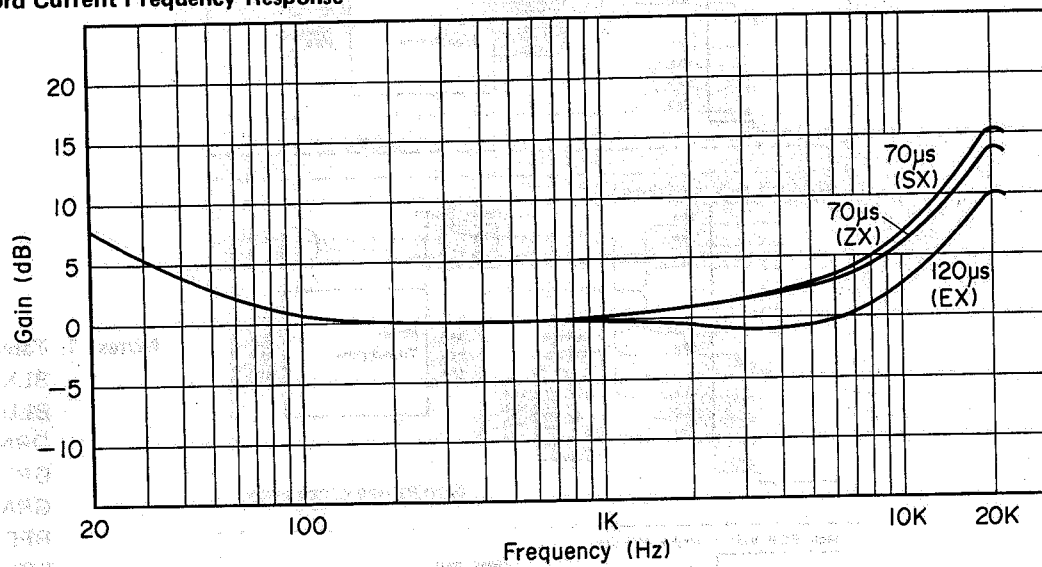
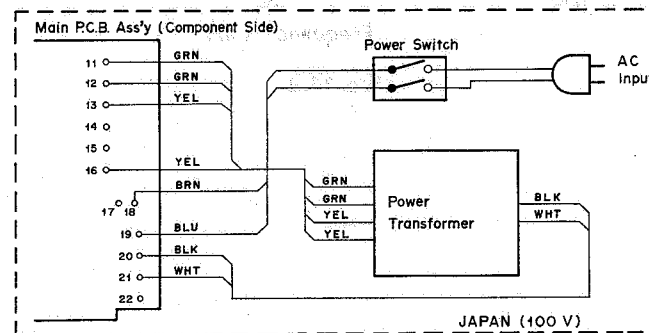
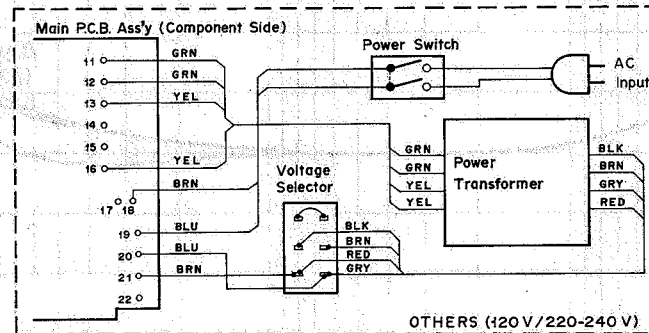
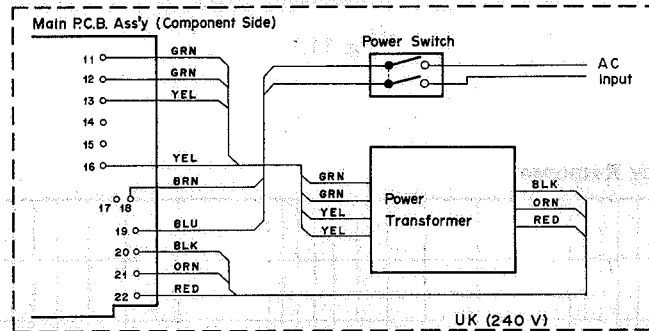
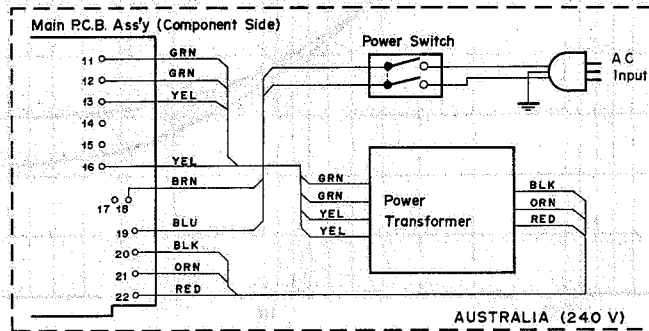
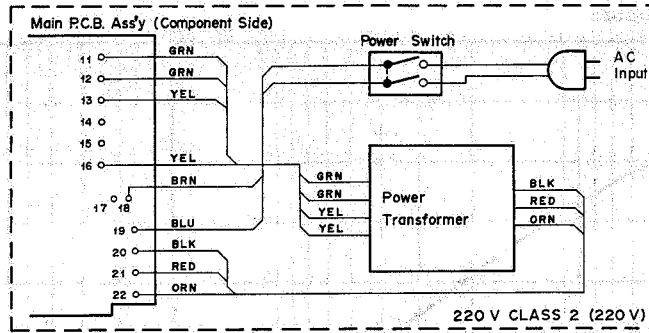

Fig. 11.2

12. WIRING DIAGRAM



- Notes: 1. Table of colors
- BLK – Black
 - BLU – Blue
 - ORN – Orange
 - GRY – Gray
 - GRN – Green
 - RED – Red
 - BRN – Brown
 - YEL – Yellow
 - WHT – White
 - VIO – Violet

2. Colors of shield wire tube
- (R) – Red
 - (W) – White
 - (B) – Black
 - (G) – Gray

Fig. 12.1

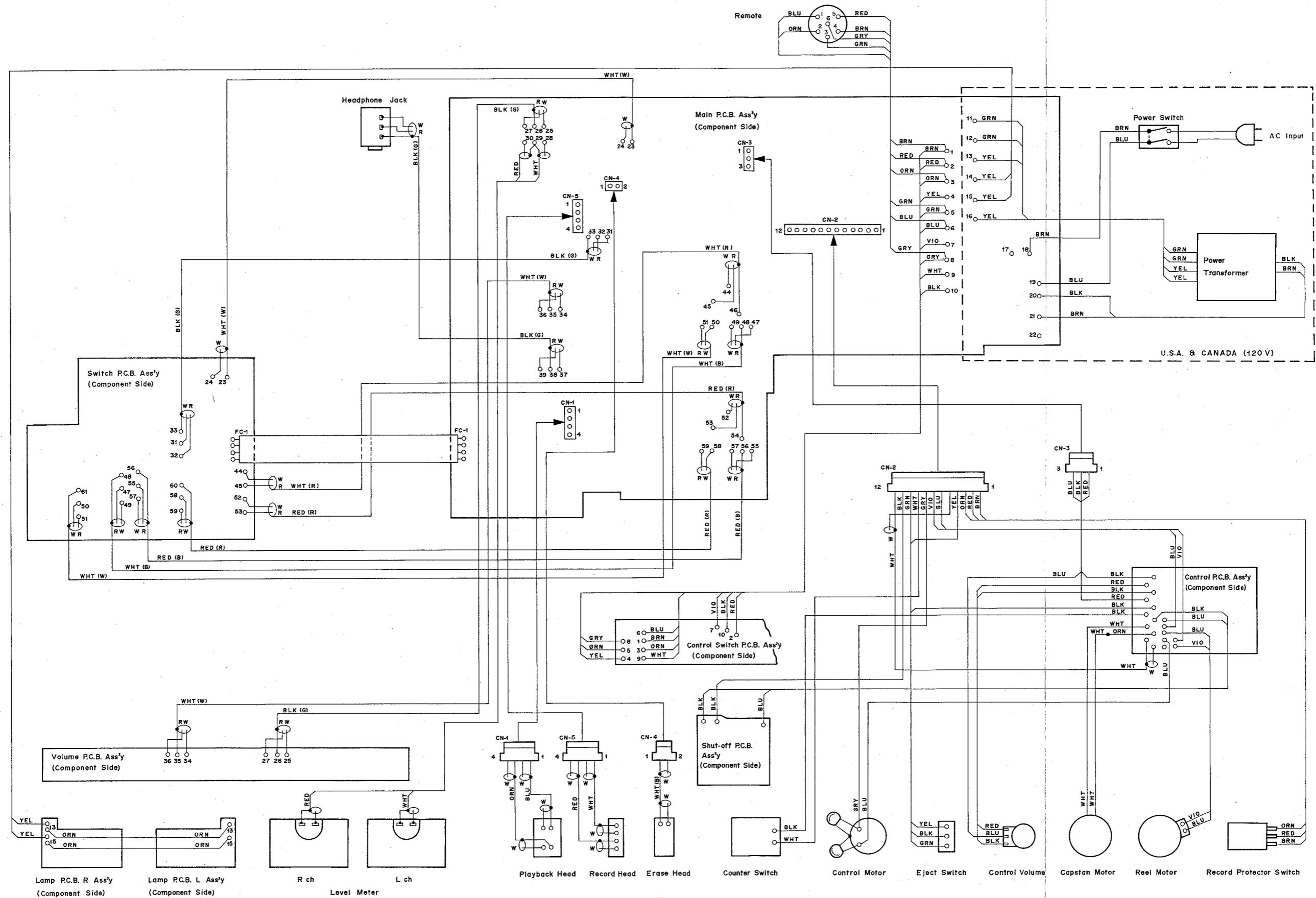

Fig. 12.2

13. BLOCK DIAGRAMS

13.1. Amplifier

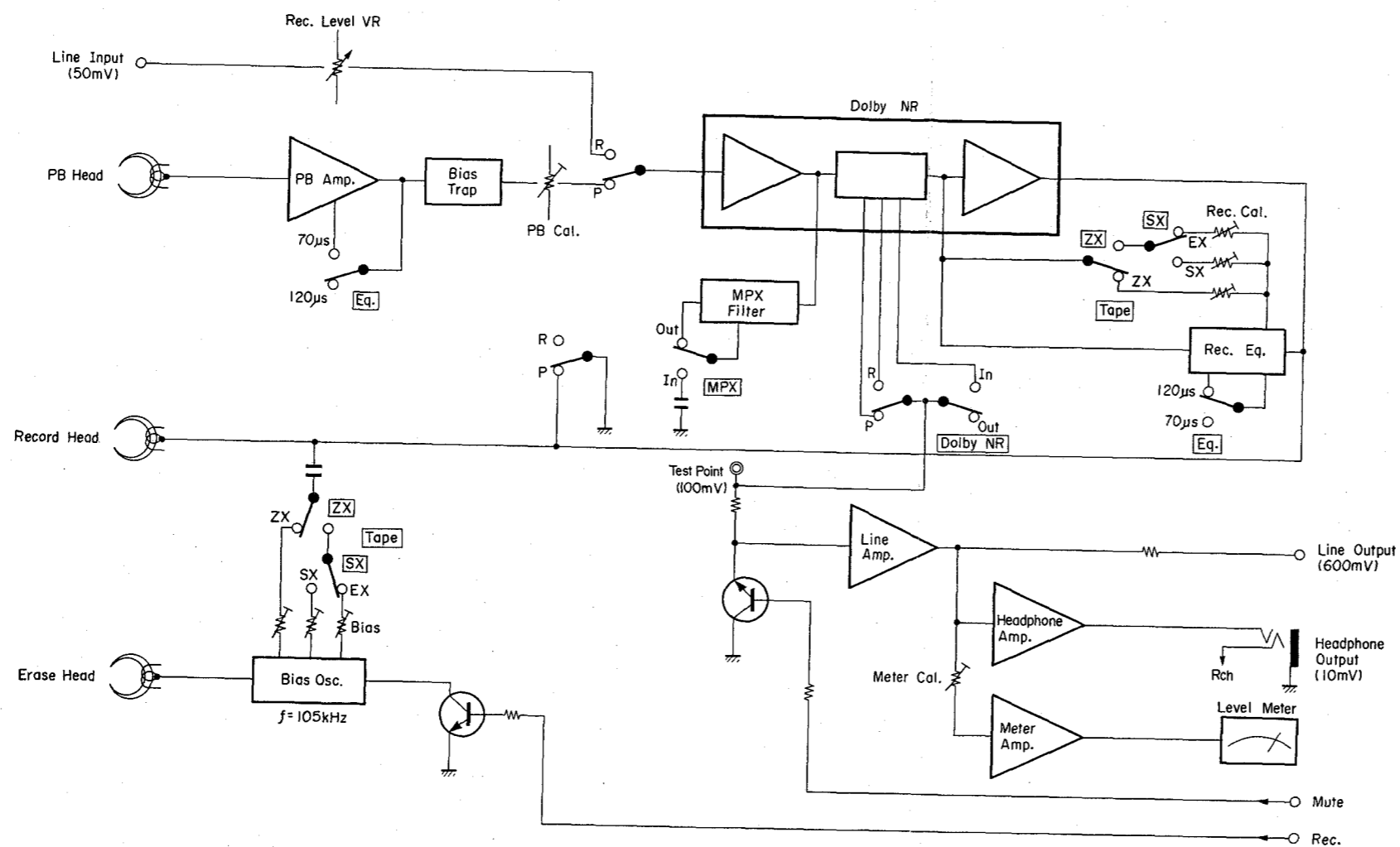

Fig. 13.1

13.2. Mechanism Control

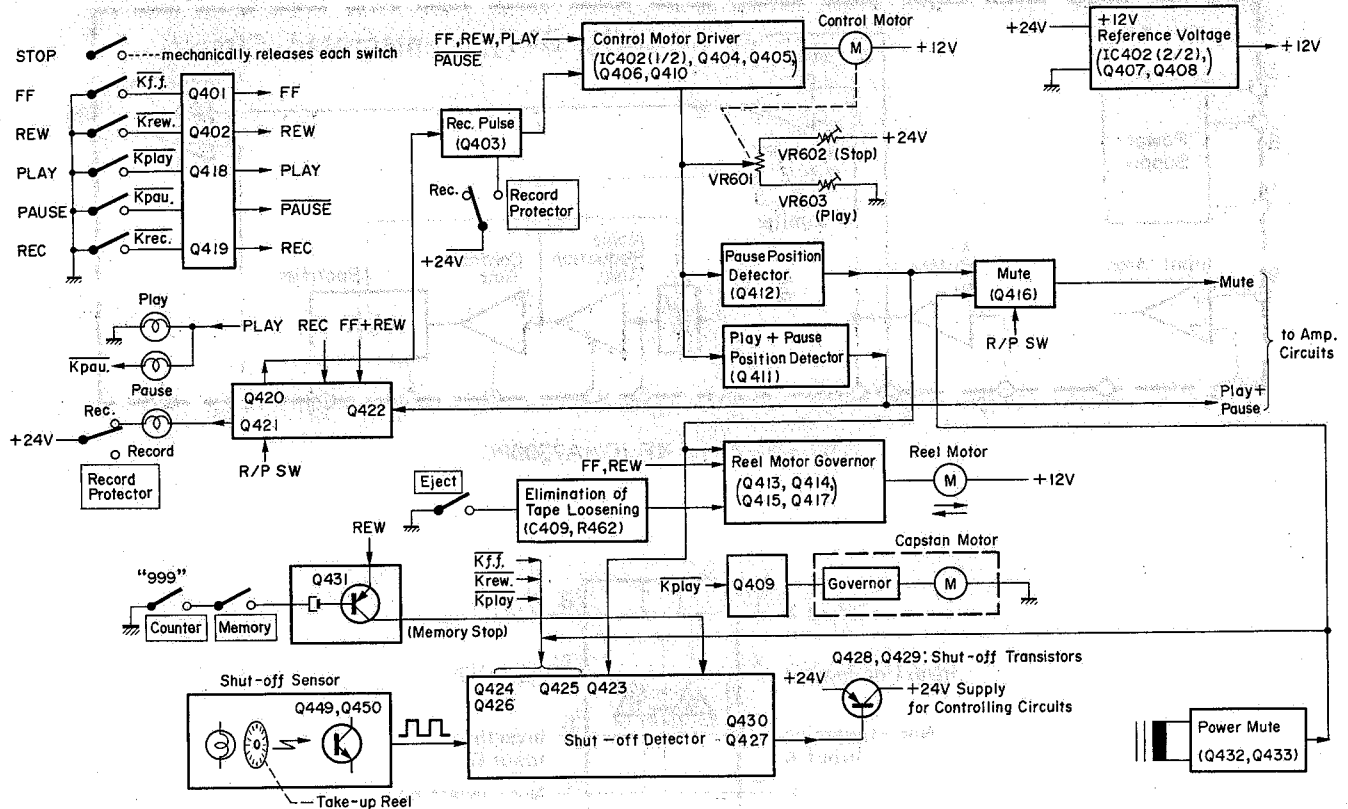

Fig. 13.2

14. SCHEMATIC DIAGRAMS

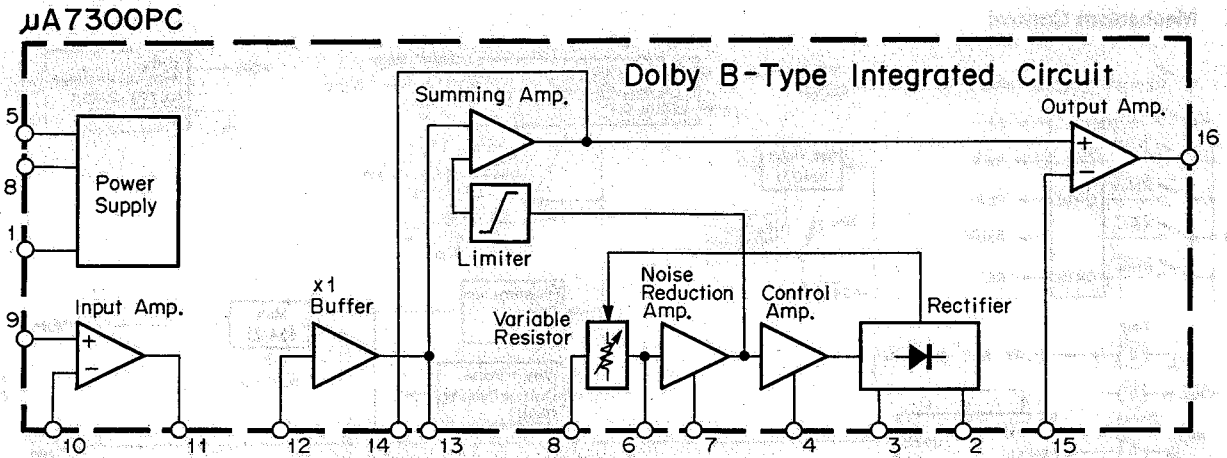

Fig. 14.1 Dolby NR IC $\mu A7300PC$

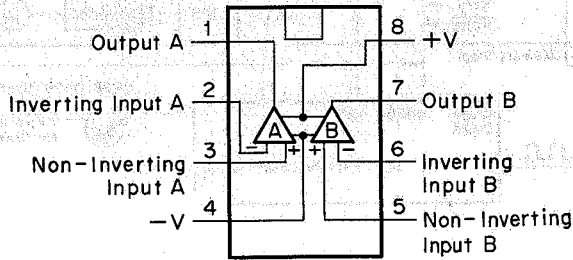

Fig. 14.2 Operational Amp. IC 4558

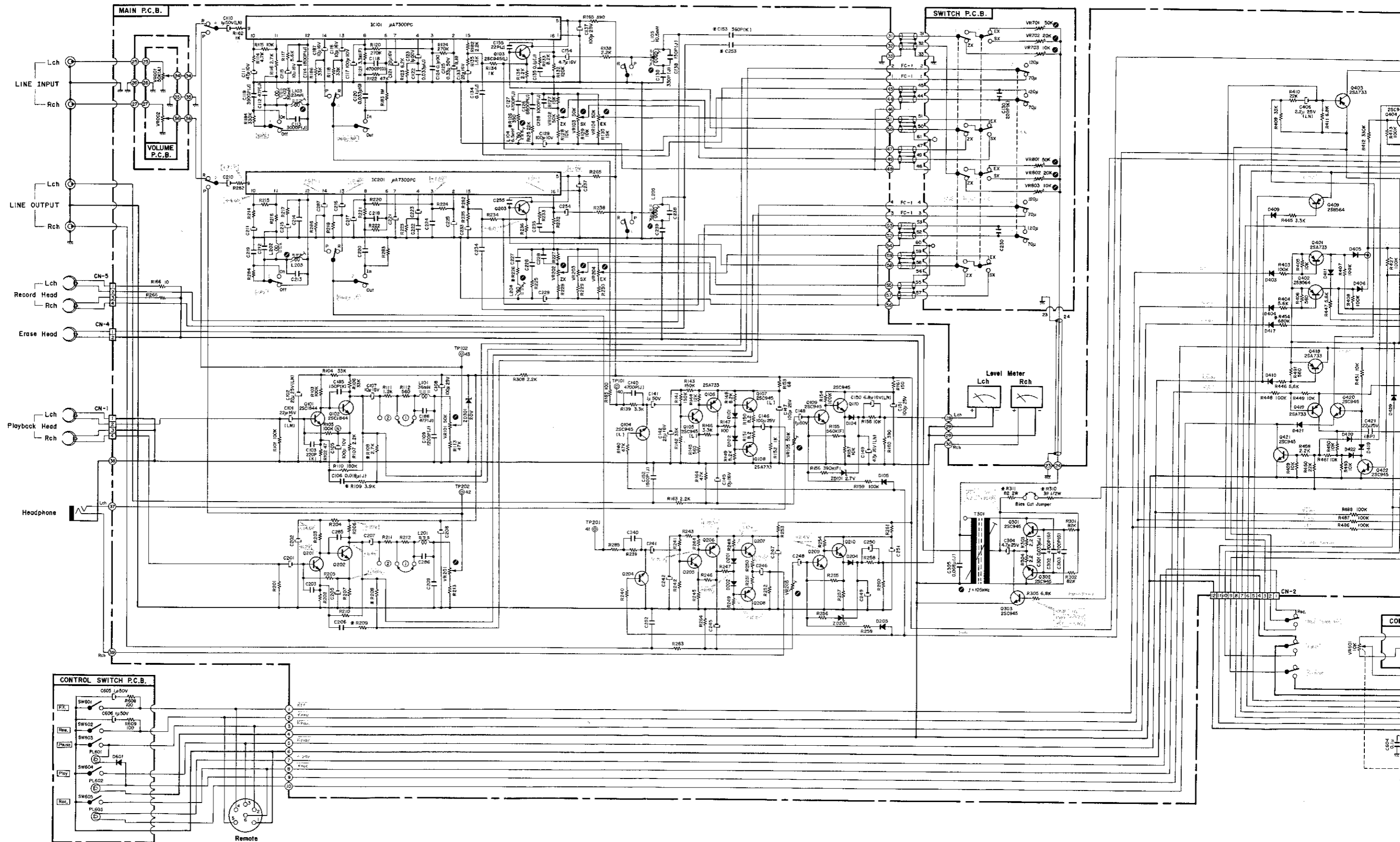
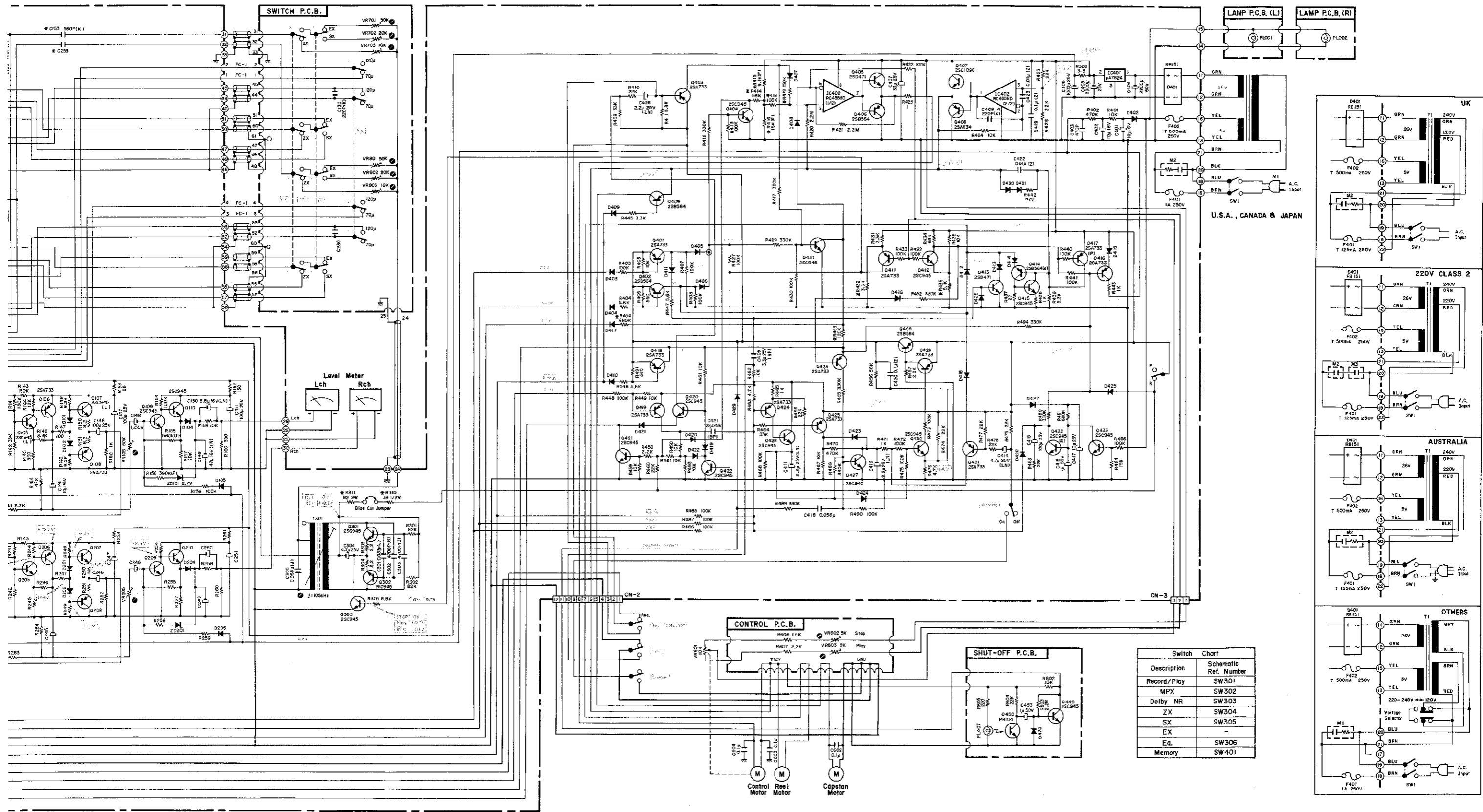

Fig. 14.3.1 Serial No.: A30605220 --



Switch Chart	
Description	Schematic Ref. Number
Record/Play	SW301
MPX	SW302
Dolby NR	SW303
ZX	SW304
SX	SW305
Eq.	SW306
Memory	SW401

Fig. 14.3.1 Serial No.: A30605220 -

Notes: 1. Diode is 1S553, 1S953, or 1S1555 unless otherwise specified.
 2. Resistor and capacitor marked with * show typical value.

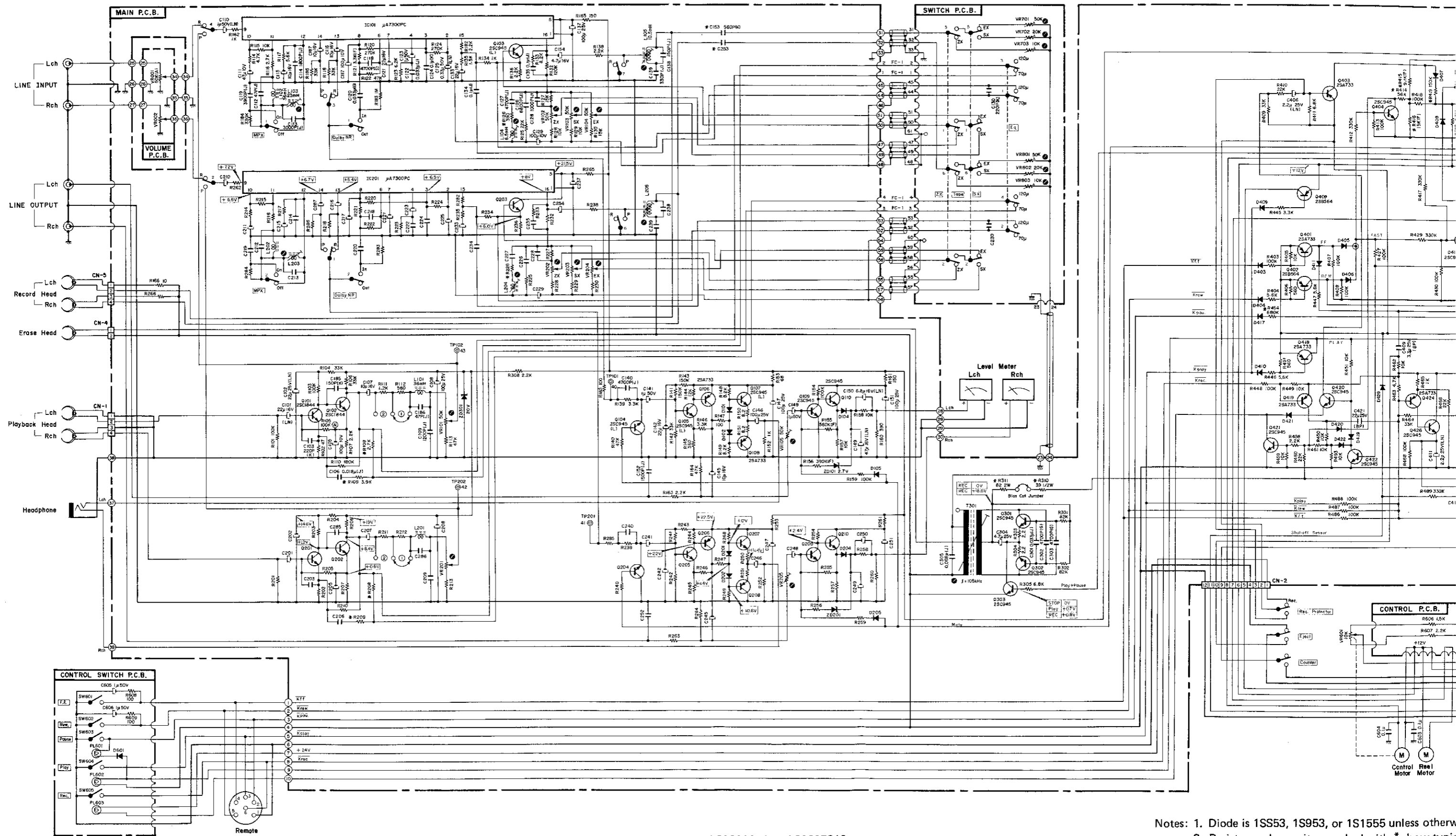
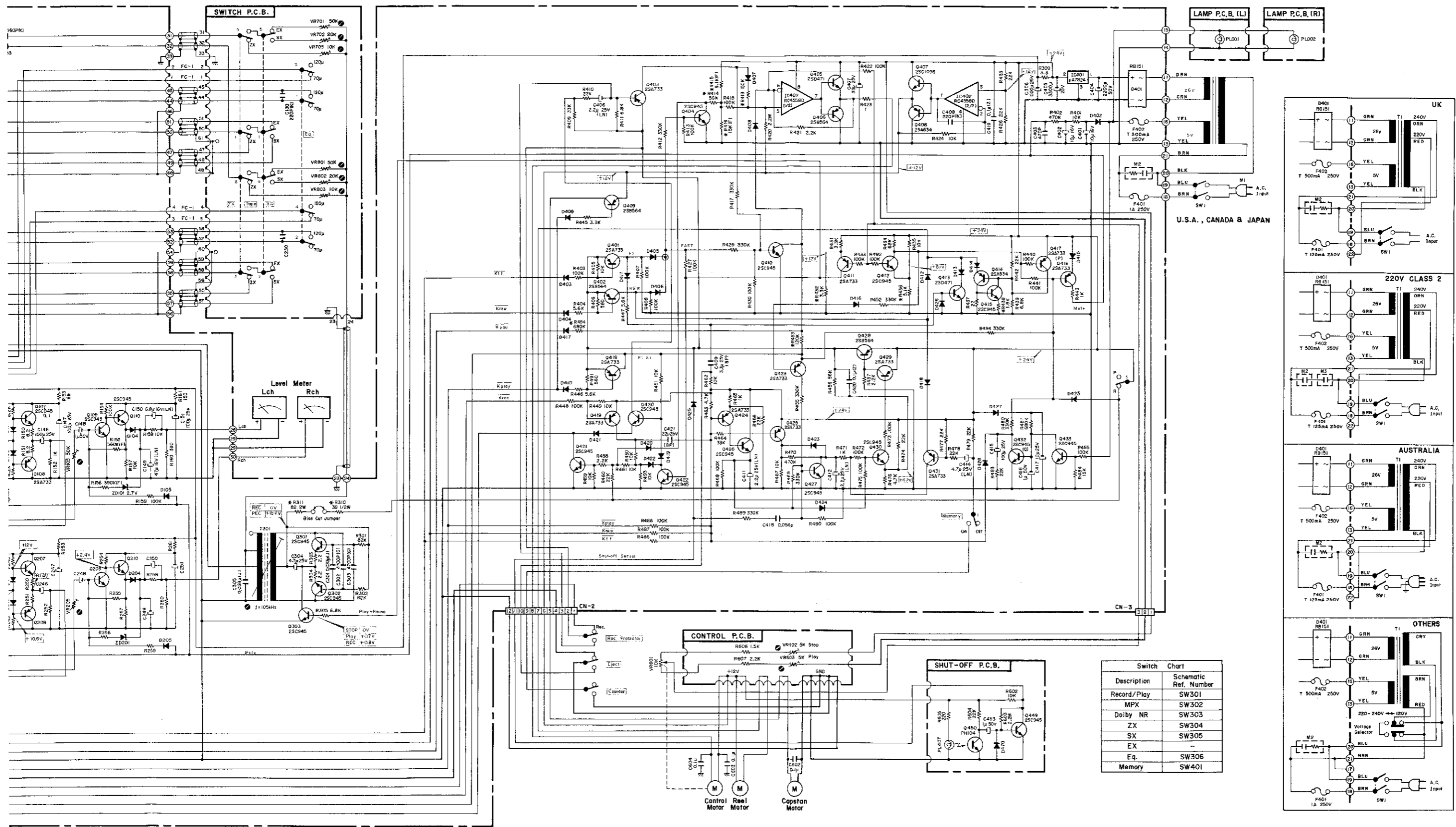

Fig. 14.3.2 Serial Nos.: A30601001 – A30605219

Notes: 1. Diode is 1S553, 1S953, or 1S1555 unless otherw
 2. Resistor and capacitor marked with * show typic



Switch Chart	
Description	Schematic Ref. Number
Record/Play	SW301
MPX	SW302
Doiby NR	SW303
ZX	SW304
SX	SW305
EX	-
Eq.	SW306
Memory	SW401

Notes: 1. Diode is 1S53, 1S953, or 1S1555 unless otherwise specified.
 2. Resistor and capacitor marked with * show typical value.

15. SPECIFICATIONS

Power Source	100, 120, 120/220–240, 220 or 240 V; 50/60 Hz (according to country of sale)
Power Consumption	23 W Max.
Tape Speed	1-7/8 ips. (4.8 cm/sec.)
Wow-and-Flutter	Less than 0.12% WTD Peak, 0.06% WTD rms
Frequency Response	20–18,000 Hz \pm 4 dB (–20dB Rec. Level)
Signal-to-Noise Ratio	Better than 63 dB at 400 Hz 3% THD, WTD rms (Dolby NR In, 70 μ s)
Total Harmonic Distortion	Less than 0.9% at 400 Hz, 0 dB (ZX Tape) Less than 1.0% at 400 Hz, 0 dB (SX, EXII Tapes)
Erasure	Better than 60 dB below saturation level at 1 kHz
Separation	Better than 36 dB at 1 kHz, 0 dB
Crosstalk	Better than 60 dB at 1 kHz, 0 dB
Bias Frequency	105 kHz
Input	50 mV, 30 k ohms
Output Level	600 mV (400 Hz, 0 dB) 2.2 k ohms
Headphone	10 mW (400 Hz 0 dB) 8 ohms
Dimensions	450(W) x 135(H) x 289(D) m/m 17-23/32(W) x 5-5/16(H) x 11-3/8(D) inches
Approximate Weight	6.4 kg, 14 lb

- Specifications and appearance design are subject to change for further improvement without notice.
- Dolby NR under license from Dolby Laboratories.
- The word "DOLBY" and the Double-D-Symbol are trademarks of Dolby Laboratories.