

SERVICE MANUAL

AE-2 CHASSIS

MODEL	COMMANDER	DEST.	CHASSIS NO.	MODEL	COMMANDER	DEST.	CHASSIS NO.
<i>KV-S3411A</i>	<i>RM-832</i>	<i>Italian</i>	<i>SCC-F18K-A</i>	<i>KV-S3413E</i>	<i>RM-832</i>	<i>Spanish</i>	<i>SCC-F33K-A</i>
<i>KV-S3411B</i>	<i>RM-832</i>	<i>French</i>	<i>SCC-F32K-A</i>	<i>KV-S3411K</i>	<i>RM-832</i>	<i>OIRT</i>	<i>SCC-F72K-A</i>
<i>KV-S3411D</i>	<i>RM-832</i>	<i>AEP</i>	<i>SCC-F26 K-A</i>	<i>KV-S3412U</i>	<i>RM-832</i>	<i>UK</i>	<i>SCC-F25J-A</i>

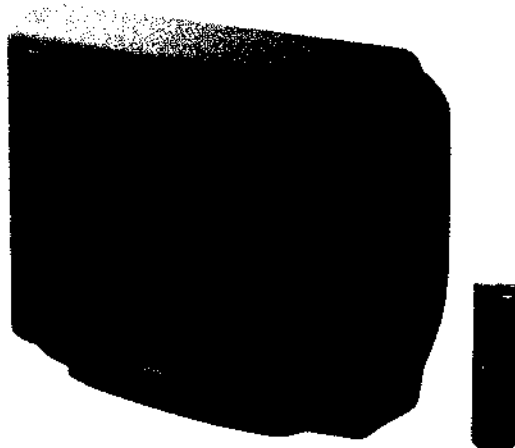

TRINITRON® COLOR TV
SONY®



ITEM	MODEL	Television system	Stereo system	Channel coverage	Color system
Italian		B/G/H, D/K	GERMAN Stereo	ITALIA VHF:A-H2 (C) UHF:21-69 PAL B/G/H VHF:E2-E12 UHF:E21-E69 CABLE TV (1):S1-S41 CABLE TV (2):S01-S05, M1-M10, U1-U10 D/K VHF:R01-R12 UHF:R21-R69	PAL, SECAM NTSC 4.43, NTSC 3.58 (VIDEO IN)
French		B/G/H, D/K L, I	GERMAN Stereo	L VHF:F02-F10 UHF:F21-F60 CABLE:B-Q B/G/H VHF:E2-E12 UHF:E21-E69 CABLE TV (1):S1-S41 CABLE TV (2):S01-S05, M1-M10, U1-U10 ITALIA VHF:A-H2 (C) UHF:21-69 D/K VHF:R01-R12 UHF:R21-R69 I UHF:B21-B69	PAL, SECAM NTSC 4.43, NTSC 3.58 (VIDEO IN)
AEP		B/G/H, D/K	GERMAN Stereo	PAL B/G/H VHF:E2-E12 UHF:E21-E69 CABLE TV (1):S1-S41 CABLE TV (2):S01-S05, M1-M10, U1-U10 ITALIA VHF:A-H2 (C) UHF:21-69 D/K VHF:R01-R12 UHF:R21-R69	PAL, SECAM NTSC 4.43, NTSC 3.58 (VIDEO IN)
Spanish		B/G/H, D/K	GERMAN/NICAM Stereo	PAL B/G VHF:E2-E12 UHF:E21-E69 CABLE TV (1):S1-S41 CABLE TV (2):S01-S05, M1-M10, U1-U10 ITALIA VHF:A-H2 (C) UHF:21-69 D/K VHF:R01-R12 UHF:R21-R69	PAL, SECAM NTSC 4.43, NTSC 3.58 (VIDEO IN)
OIRT		B/G/H, D/K	GERMAN Stereo	B/G/H VHF:E2-E12 UHF:E21-E69 CABLE TV (1):S1-S41 D/K VHF:R1-R12 UHF:R21-R60	PAL, SECAM NTSC 4.43, NTSC 3.58 (VIDEO IN)
UK		I	NICAM Stereo	UHF:B21-B69	PAL SECAM, NTSC 4.43 NTSC 3.58 (VIDEO IN)

MODEL	Italian	French	AEP	Spanish	OIRT	UK
Power consumption	130Wh	136Wh	150Wh	154Wh	136Wh	228Wh

SPECIFICATIONS

- ⊗ 1 21-pin Euro connector (CENELEC standard)
 - inputs for audio and video signals
 - inputs for RGB
 - outputs of TV video and audio signals
- ⊗ 2/⊗ 2 21-pin Euri connector
 - inputs for audio and video signals
 - inputs for S video
 - outputs for audio and video signals (selectable)
- ⊗ 4/⊗ 21-pin Euro connector
 - inputs for audio and video signals
 - inputs for S video
 - outputs for audio and video signals (monitor out)
- ⊗ 2, /⊗ 4 S video inputs
 - 4-pin DIN
- ⊗ Audio inputs (L, R) phono jacks
- ⊗ S video output-4pin DIN
- ⊗ Audio outputs - phono jacks
- ⊗ Audio outputs (variable) - phono jacks
- External speaker terminals : 2-pin DIN

[FRONT]

- ⊗ 3 Video input - phono jack
- ⊗ Audio inputs - phono jacks
- ⊗ 3 S video input 4-pin DIN
- ⊗ Headphone jacks : Stereo minijack

- Sound output 2 × 15 (RMS)
2 × 35 (Music)
- Power requirement 220-240V
- Dimensions Approx. 813 × 648 × 596 mm
- Weight Approx. 79kg
- Supplied accessories RM-832 Remote Commander(1)
IEC designation R6 batteries(2)
- Other features NICAM, FASTTEXT

[RM-832]

- Remote control system infrared control
- Power requirements 3V dc
2 batteries IEC designation
R6 (size AA)
- Dimensions Approx. 65 × 222 × 21 mm (w/h/d)
- Weight Approx. 157kg
(Not including Batteries)

Design and specifications are subject to change without notice.

	KV-S3411A	KV-S3411B	KV-S3411D	KV-S3413E	KV-S3411K	KV-S3412U
Pal Comb	ON	ON	ON	ON	ON	ON
P i P	ON	ON	ON	ON	ON	ON
RGB Priority	ON	OFF	ON	ON	ON	ON
Woofers Box	OFF	OFF	OFF	OFF	OFF	OFF
Scart 1	ON	ON	ON	ON	ON	ON
Scart 2	ON	ON	ON	ON	ON	ON
Front In (3)	ON	ON	ON	ON	ON	ON
Scart 4	ON	ON	ON	ON	ON	ON
Dyn. Convergence	ON	ON	ON	ON	ON	ON
Projector	OFF	OFF	OFF	OFF	OFF	OFF
AKB in 16:9 mode	ON	ON	ON	ON	ON	ON
Norm B/G	ON	ON	ON	ON	ON	OFF
Norm 1	OFF	ON	OFF	OFF	OFF	ON
Norm D/K	ON	ON	ON	ON	ON	OFF
Norm AUS	OFF	OFF	OFF	OFF	OFF	OFF
Norm L	OFF	ON	OFF	OFF	OFF	OFF
Norm SAT	OFF	OFF	OFF	OFF	OFF	OFF
Norm M	OFF	OFF	OFF	OFF	OFF	OFF
Language Preset	italiano	Francais	Deutsch	Espanol	English	English

WARNING KV-S3412U only

The flexible mains lead is supplied to connected a B.S. 1363 fused plug having a fuse of 5 amp capacity. Should the fuse need to be replaced, use a 5 AMP FUSE approved by ASTA to BS 1362, ie carries the  mark.

If the plug supplied with this appliance is not suitable for your socket outlets in your home, it should be cut off and an appropriate plug fitted.

The plug severed from the mains lead must be destroyed as a plug with bared wires is dangerous if engaged in a live socket outlet.

When an alternative type of plug is used it should be fitted with a 5 AMP FUSE, otherwise the circuit should be protected by a 5 AMP FUSE at the distribution board.

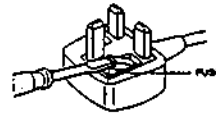

How to replace the fuse

Open the fuse compartment with the blade screwdriver, and replace the fuse.

21 pin connector (1 2/ 4)

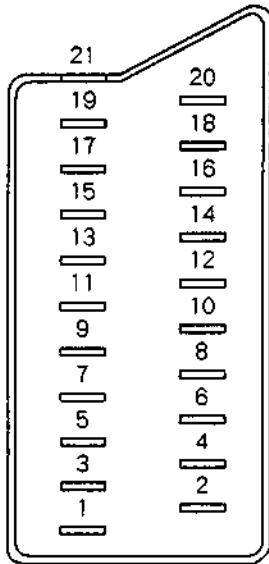
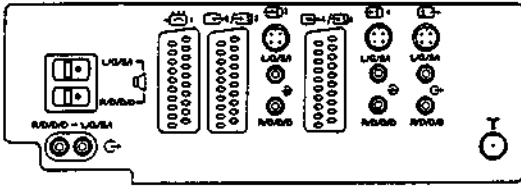

Pin No	1	2	4	Signal	Signal level
1	○	○	○	Audio output B (right)	Standard level : 0.5Vrms Output impedance : Less than 1kohm *
2	○	○	○	Audio input B (right)	Standard level : 0.5Vrms Input impedance : More than 10kohms *
3	○	○	○	Audio output A (left)	Standard level : 0.5Vrms Output impedance : Less than 1kohm *
4	○	○	○	Ground (audio)	
5	○	○	○	Ground (blue)	
6	○	○	○	Audio input A (left)	Standard level : 0.5Vrms Input impedance : More than 10kohms *
7	○	●	●	Blue input	0.7 ± 3dB, 75ohms, positive
8	○	○	○	Function select (AV control)	High state (9.5 - 12V) : Part mode Low state (0 - 2V) : TV mode Input impedance : More than 10kohms Input capacitance : Less than 2nF
9	○	○	○	Ground (green)	
10	○	○	○	Open	
11	○	●	●	Green	Green signal : 0.7V ± 3dB, 75ohms, positive
12	○	○	○	Open	
13	○	○	○	Ground (red)	
14	○	○	○	Ground (blanking)	
15	○	-	-	Red input	0.7V ± 3dB, 75ohms, positive
	-	○	○	(S signal) chroma input	0.3V ± 3dB, 75ohms, positive
16	○	●	●	Blanking input (Ys signal)	High state (1 - 3V) Low state (0 - 0.4V) Input impedance : 75ohms
17	○	○	○	Ground (video output)	
18	○	○	○	Ground (video input)	
19	○	○	○	Video output	1V ± 3dB, 75ohms, positive Sync : 0.3V (-3, +
20	○	-	-	Video input	1V ± 3dB, 75ohms, positive Sync : 0.3V (-3, +
	-	○	○	Video Input/Y (S signal)	1V ± 3dB, 75ohms, positive Sync : 0.3V (-3, + 10dB)
21	○	○	○	Common ground (plug, shield)	

○ Connected ● unconnected (open) * at 20Hz - 20kHz

4 Pin connector (3)

Pin No	Signal	Signal level
1	Ground	
2	Ground	
3	Y (S signal) input	1V ± 3dB 75ohm, positive Sync 0.3V \pm 3 dB
4	C (S signal) input	0.3V ± 3dB 75ohm, positive

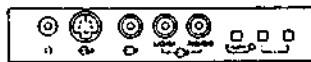

TABLE OF CONTENTS

<u>Section</u>	<u>Title</u>	<u>Page</u>	<u>Section</u>	<u>Title</u>	<u>Page</u>
1. GENERAL			4. CIRCUIT ADJUSTMENTS		
1-1.	Overview	6	4-1.	Electrical Adjustments	30
1-2.	Step 3 Tuning in to TV stations	7	4-2.	Volume Electrical Adjustments	34
1-3.	Additional Presetting Functions	8	4-3.	Test Mode 2 :	35
1-4.	Watching the TV	10	4-4.	Error Message	36
1-5.	Adjusting and Setting the TV Using the Menu	11	4-5.	Error II C Bus Diagnosis System in AE2 Chassis	36
1-6.	PIP (Picture-In-Picture)	12	5. DIAGRAMS		
1-7.	Teletext	12	5-1.	Block Diagram (1)	37
1-8.	Connecting and Operating optional Equipment	14	5-2.	Block Diagram (2)	41
1-9.	For Your Information	16	5-3.	Circuit Boards Location	45
2. DISASSEMBLY			5-4.	Schematic Diagrams and Printed Wiring Boards	45
2-1.	Rear Cover Removal	17	• H1 Board	46	
2-2.	Speaker Removal	17	• H2 Board	46	
2-3.	Chassis Assy Removal	18	• F2 Board	47	
2-4.	Service Position	18	• F1 Board	47	
2-5.	M, V and A1 Boards Removal	19	• J Board	50	
2-6.	D2 and B1 Boards Removal	19	• A Board	55	
2-7.	Extension Board	20	• M Board	62	
2-8.	F Bracket Removal	20	• D Board	67	
2-9.	J Board Removal	21	• V Board	71	
2-10.	P Board Removal	21	• P Board	73	
2-11-1.	Wire Rod	22	• B Board	73	
2-11-2.	Wire Rod	22	• D1 Board	80	
2-12.	Degaussing Coil Removal	23	• A1 Board	83	
2-13.	Picture Tube Removal	24	• VM Board	86	
3. SET-UP ADJUSTMENTS			• C Board	87	
3-1.	Beam Landing	25	• IF Board	90	
3-2.	Convergence	26	5-5.	Schematic Diagram of Tuner	97
3-3.	Focus	29	5-6.	Semiconductors	98
3-4.	White Balance	29	6. EXPLODED VIEWS		
			6-1.	Chassis	100
			6-2.	Picture Tube	101
			7. ELECTRICAL PARTS LIST		102

CAUTION

SHORT CIRCUIT THE ANODE OF THE PICTURE TUBE AND THE ANODE CAP TO THE METAL CHASSIS, CRT SHIELD, OR CARBON PAINTED ON THE CRT, AFTER REMOVING THE ANODE.

WARNING !!

AN ISOLATION TRANSFORMER SHOULD BE USED DURING ANY SERVICE TO AVOID POSSIBLE SHOCK HAZARD, BECAUSE OF LIVE CHASSIS. THE CHASSIS OF THIS RECEIVER IS DIRECTLY CONNECTED TO THE AC POWER LINE.

SAFETY-RELATED COMPONENT WARNING!!

COMPONENTS IDENTIFIED BY SHADING AND MARK Δ ON THE SCHEMATIC DIAGRAMS, EXPLODED VIEWS AND, IN THE PARTS LIST ARE CRITICAL FOR SAFE OPERATION. REPLACE THESE COMPONENTS WITH SONY PARTS WHOSE PART NUMBERS APPEAR AS SHOWN IN THIS MANUAL OR IN SUPPLEMENTS PUBLISHED BY SONY.

ATTENTION

APRES AVOIR DECONNECTE LE CAP DE L'ANODE, COURT-CIRCUITER L'ANODE DU TUBE CATHODIQUE ET CELUI DE L'ANODE DU CAP AU CHASSIS METALLIQUE DE L'APPAREIL, OU AU COUCHE DE CARBONE PEINTE SUR LE TUBE CATHODIQUE OU AU BLINDAGE DU TUBE CATHODIQUE.

ATTENTION!!

AFIN D'EVITER TOUT RISQUE D'ELECTROCUTION PROVENANT D'UN CHASSIS SOUS TENSION, UN TRANSFORMATEUR D'ISOLEMENT DOIT ETRE UTILISE LORS DE TOUT DEPANNAGE. LE CHASSIS DE CE RECEPTEUR EST DIRECTEMENT RACCORDE A L'ALIMENTATION SECTEUR.

ATTENTION AUX COMPOSANTS RELATIFS A LA SECURITE!!

LES COMPOSANTS IDENTIFIES PAR UNE TRAME ET PAR UNE MARQUE Δ SUR LES SCHEMAS DE PRINCIPE, LES VUES EXPLOSEES ET LES LISTES DE PIECES SONT D'UNE IMPORTANCE CRITIQUE POUR LA SECURITE DU FONCTIONNEMENT. NE LES REMPLACER QUE PAR DES COMPOSANTS SONY DONT LE NUMERO DE PIECE EST INDIQUE DANS LE PRESENT MANUEL OU DANS DES SUPPLEMENTS PUBLIES PAR SONY.

1-1. OVERVIEW

SECTION 1 GENERAL

The operating instructions mentioned here are partial abstracts from the Operating Instruction Manual. The page numbers of the Operating Instruction Manual remain as in the manual.

This section briefly describes the buttons and controls on the TV set and on the Remote Commander. For more information, refer to the pages given next to each description.

TV set-front

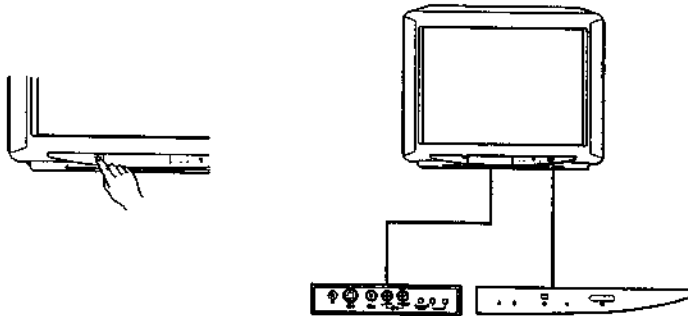

Symbol	Name	Refer to page
⊕	Main power switch	14
○	Standby indicator	14
A-B	Stereo A/B indicators	16
📻	Headphones jack	22
⊕, ⊖, ⊕, ⊖	Input jacks (S video/video/audio)	22
⏪, ⏩, ⊕, ⊖	Function selector (Programme/volume/input)	15
↔	Adjustment buttons for function selector	15

Remote commander RM-832

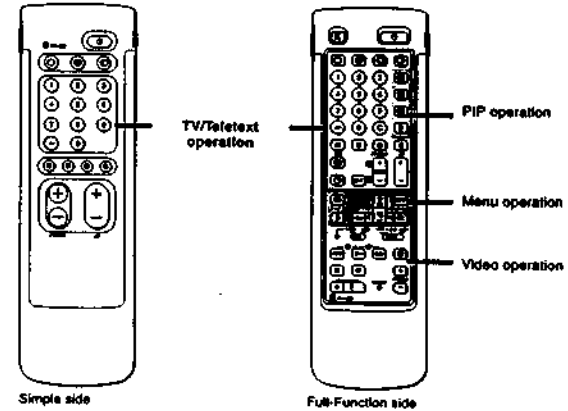

Note
The SAT button does not operate with this TV.

TV/Teletext operation

Symbol	Name	Refer to page
⏻	Muting on/off button	15
⊕	Standby button	14
⊕	TV power on/TV mode selector button	14
⊕	Teletext button	15
⊕	Input mode selector	15
⊕	Output mode selector	23
1,2,3,4,5,6,7,8,9 and 0	Number buttons	14
↵	Double-digit entering button	14
C	Direct channel entering button	13
Δ/±	Volume control button	14
PROGR +/-	Programme selectors	14
⊕	Teletext page access buttons	19
⊕	Picture adjustment button	16
f	Sound adjustment button	18
⊕	On-screen display button	15
⊕	Teletext hold button	19
⊕	Time display button	15
⊕	Fastext buttons	19

PIP (Picture-in-Picture) operation

Symbol	Name	Refer to page
⊕	PIP on / off button	18
↑	PIP source selector	18
⊕	Swap button	18
⊕	PIP position changing button	18

Menu operation

Symbol	Name	Refer to page
MENU	Menu on / off button	8
Δ+/V-	Select buttons	8
OK	OK (confirming) button	8
←	Back button	8

Video operation

Symbol	Name	Refer to page
MEM USE	MEM/USE switch	25
MEM	MEM indicator	25
VTR 1/2/3, MDP	Video equipment selector	25
⏪, ⏩, ⊕, ⊖	Video equipment operation buttons	25
PROGR +/-	RESET button	25

1-2. STEP 3 – TUNING IN TO TV STATIONS

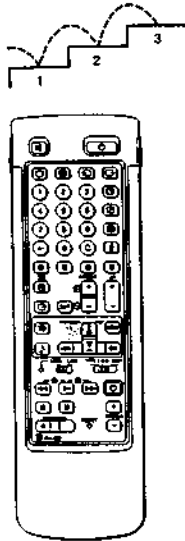

Once you have set up the TV, you can choose the language of the menu. Then you should preset the channels (up to 100 channels) by choosing either the automatic or manual method.

The automatic method is easier if you want to preset all receivable channels at once. Use the manual method if you only have a few channels and want to preset channels one by one. The manual method is also convenient for allocating programme numbers to various video input sources.

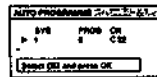

Auto Menu

PROG	SYS	CH	SEARCH	LABEL	APT
1	1	CH1	00	---	---
2	1	CH2	00	---	---
3	1	CH3	00	---	---
4	1	CH4	00	---	---
5	1	CH5	00	---	---
6	1	CH6	00	---	---
7	1	CH7	00	---	---
8	1	CH8	00	---	---
9	1	CH9	00	---	---

Manual Menu

Before you begin

- Check that the Full-Function side of the Remote Commander is visible.
- Locate Menu operation buttons on the Remote Commander. They are shaded in the illustration at the left.

1 Display the Menu

- 1 Depress **0** on the TV. The TV will switch on. If the standby indicator on the TV is lit, press **0** or a number button on the Remote Commander. Press the MENU button. The main menu appears. (See Fig. 1.)



2 Choose a language

- 1 Select «Language» with the **Δ** or **∇** button and press the OK button. The LANGUAGE menu appears. (See Fig. 2.)
- 2 Select the language you want with **Δ** or **∇** and press OK, then press **←**.

Now, choose one of the following methods
 «Preset Channels Automatically»
 or
 «Preset Channels Manually».

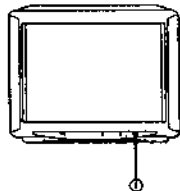

To go back to main menu
 Keep pressing **←**

To go back to the normal TV picture
 Press MENU.

Note on the DEMO function
 If you choose «Demo» on the main menu, you can see a sequential demonstration on the menu functions.



Fig. 1.



Fig. 2.

With this method, you can preset all receivable channels at once.

To stop automatic channel presetting Press **←** on the Remote Commander.

Notes
 • After presetting the channels automatically, you can check which channels are stored on which programme positions. For details, see «Using the Programme Table» on page 16.

• You can exchange the programme positions to have them appear on screen in the order you like. For details, see «Exchanging the Programme Positions» on page 10.

Use this method if there are only a few channels in your area to preset or if you want to preset channels one by one. You may also allocate programme numbers to various video input sources.

If you have made a mistake Press **←** to go back to the previous position. To go back to main menu Keep pressing **←**. To go back to the normal TV picture Press MENU.

3 Preset channels automatically

- 1 Select «Preset» with **Δ** or **∇** and press OK. The PRESET menu appears. (See Fig. 3.)
- 2 Select «Auto Programme» with **Δ** or **∇** and press OK. The AUTO PROGRAMME menu appears. (See Fig. 4.)
- 3 Press OK repeatedly until the first element of the «PROG» number is highlighted.
- 4 Select the programme (number button) from which you want to start presetting. Select the first element of the double-digit number with **Δ** or **∇** or the number buttons (e.g. For «04», select «0» here) and press OK. The second element of «PROG» will be highlighted.
- 5 Select the second element of the double-digit number with **Δ** or **∇** or the number buttons (e.g. For «04», select «4» here) (See Fig. 5.) and press OK.
- 6 Press OK. The automatic channel presetting starts.

When presetting is finished, the preset menu reappears. All available channels are now stored on successive number buttons.



Fig. 3.

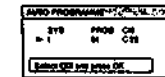

Fig. 4.

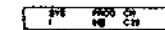

Fig. 5.

3 Preset channels manually

- 1 Select «Preset» with **Δ** or **∇** and press OK. The PRESET menu appears. (See Fig. 6.)
- 2 Select «Manual Programme Preset» with **Δ** or **∇** and press OK. The MANUAL PROGRAMME PRESET menu appears. (See Fig. 7.)

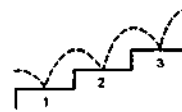

Fig. 6.

PROG	SYS	CH	SEARCH	LABEL	APT
1	1	CH1	00	---	---
2	1	CH2	00	---	---
3	1	CH3	00	---	---
4	1	CH4	00	---	---
5	1	CH5	00	---	---
6	1	CH6	00	---	---
7	1	CH7	00	---	---
8	1	CH8	00	---	---
9	1	CH9	00	---	---

Fig. 7.

1-3. ADDITIONAL PRESETTING FUNCTIONS



To tune in a channel by frequency
After selecting F in step 5, enter three digits using the number buttons.

- 3 Using Δ + or ∇ -, select the programme position (number button) to which you want to preset a channel, and press OK.
- 4 Select if necessary, a video input source (EXT) with Δ + or ∇ -. Then press OK. The CH position will be highlighted. (See Fig. 8.)
- 5 Using Δ + or ∇ -, select C (to preset a regular channel) or F (to tune in by frequency) and press OK. The first element of the »CH« number will be highlighted. If you have selected EXT in step 4, select the video input source with Δ + or ∇ -. (See Fig. 9.)

There are two ways to preset channels. If you know the channel number, go to step »6-Manual«, or
if you don't know the channel number, go to step »6-Search«.

6 Manual

- a Select the first element of the »CH« number with Δ + or ∇ - or the number buttons and press OK. The second element of the »CH« number will be highlighted.
- b Select the second element of the number with Δ + or ∇ - or the number buttons. The selected number appears. (See Fig. 10.)
- c Press OK. The »SEARCH« position is highlighted and the selected channel is now stored. (See Fig. 11.)
- d Press OK until the cursor appears by the next programme position.
- e Repeat steps 3 to 6 to preset other channels.

6 Search

- a Press OK repeatedly until the colour of the SEARCH position changes.
- b Start searching for the channel with Δ + (up) or ∇ - (down). The CH position changes colour. (See Fig. 12.) The CH number starts counting up or downwards. When a channel is found, it stops. (See Fig. 13.)
- c Press OK if you want to store this channel. If not, press Δ + or ∇ - to continue channel searching.
- d Press OK until the cursor appears by the next programme position.
- e Repeat steps 3 to 6 to preset other channels.

If you have made a mistake
Press \leftarrow to go back to the previous position.
To go back to main menu
Keep pressing \leftarrow .
To go back to the normal TV picture
Press MENU.



Fig. 8.

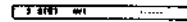

Fig. 9.



Fig. 10.



Fig. 11.

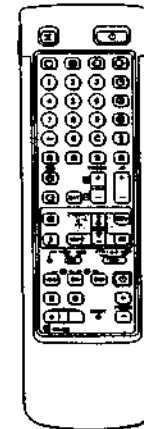

Fig. 12.



Fig. 13.

PROGRAMME EXCHANGE



For programme positions beyond 15
The display scrolls automatically.

If you have made a mistake
Press \leftarrow to go back to the previous position.

To go back to main menu
Keep pressing \leftarrow .

To go back to the normal TV picture
Press MENU.

This section shows you additional presetting functions such as exchanging or skipping programme positions, captioning a station name, manual fine-tuning, and using the parental lock.

Before you begin

- Check that the Full Function side of the Remote Commander is visible.
- Locate the Menu operation buttons.

Exchanging Programme Positions

With this function, you can exchange the programme positions to a preferable order.

- 1 Press MENU to display the main menu.
- 2 Select »Preset« with Δ + or ∇ - and press OK. The PRESET menu appears.
- 3 Select »Programme Exchange« with Δ + or ∇ - and press OK. The PROGRAMME EXCHANGE menu appears. (See Fig. 14.)
- 4 Using Δ + or ∇ -, select the programme position you want to exchange with another and press OK. The colour of the selected position changes. (See Fig. 15.)
- 5 Using Δ + or ∇ -, select the programme position to be exchanged and press OK. Now the two programme positions have been exchanged. (See Fig. 16.)
- 6 Repeat steps 4 and 5 to exchange other programme positions.

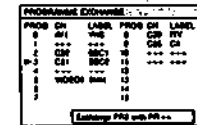

Fig. 14.



Fig. 15.

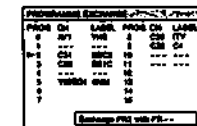

Fig. 16.

Tuning in a Channel Temporarily

You can tune in a channel temporarily, even when it has not been preset. Use the buttons on the Full-Function side of the Remote Commander.

- 1 Press C on the Remote Commander. The indication »C« appears on the screen.
- 2 Enter the double-digit channel number using the number buttons (e.g. for channel 4, first press 0, then 4). The channel appears. However, the channel will not be stored.



MANUAL PROGRAMME PRESET

Skipping Programme Positions

You can skip unused programme positions when selecting programmes with the PROGR +/- buttons. However, the skipped programmes may still be called up when you use the number buttons.

- 1 Press MENU to display the main menu.
- 2 Select »Preset« with Δ + or ▽ - and press OK. The PRESET menu appears.
- 3 Select »Manual Programme Preset« with Δ + or ▽ - and press OK. The MANUAL PROGRAMME PRESET menu appears. (See Fig. 17.)
- 4 Using Δ + or ▽ -, select the programme position which you want to skip and press OK. The »SYS« position changes colour.
- 5 Press Δ + or ▽ - until «----» appears in the SYSTEM position. (See Fig. 18.)
- 6 Press OK. (See Fig. 19.) When you select programmes using the PROGR +/- buttons, the programme position will be skipped.
- 7 Repeat steps 4 to 6 to skip other programme positions.



PROG	SYS	CH	SEARCH	LABEL	AFT
1	1	CH1	01	01	000
2	1	CH2	02	02	000
3	1	CH3	03	03	000
4	1	CH4	04	04	000
5	1	CH5	05	05	000
6	1	CH6	06	06	000
7	1	CH7	07	07	000
8	1	CH8	08	08	000
9	1	CH9	09	09	000
10	1	CH10	10	10	000

Fig. 17.

3	---
---	-----

Fig. 18.

2	---
---	-----

Fig. 19.

Captioning a Station Name

You can »name« a channel or an input video source using up to five characters (letters or numbers) to be displayed on the TV screen (e.g. BBC1). Using this function, you can easily identify which channel or video source you are watching.

- 1 Press MENU to display the main menu.
- 2 Select »Preset« with Δ + or ▽ - and press OK. The PRESET menu appears.
- 3 Select »Manual Programme Preset« with Δ + or ▽ - and press OK. The MANUAL PROGRAMME PRESET menu appears. (See Fig. 20.)
- 4 Using Δ + or ▽ -, select the programme position you want to caption and press OK repeatedly until the first element of the LABEL position is highlighted.
- 5 Select a letter or number with Δ + or ▽ - and press OK. The next element will be highlighted. Select other characters in the same way. If you want to leave an element blank, select - and press OK. (See Fig. 22.)
- 6 After selecting all the characters, press OK repeatedly until the cursor appears by the next programme position (at the left margin). Now the caption you chose is stored. (See Fig. 21.)
- 7 Repeat steps 5 and 6 to caption names for other channels.

PROG	SYS	CH	SEARCH	LABEL	AFT
1	1	CH1	01	01	000
2	1	CH2	02	02	000
3	1	CH3	03	03	000
4	1	CH4	04	04	000
5	1	CH5	05	05	000
6	1	CH6	06	06	000
7	1	CH7	07	07	000
8	1	CH8	08	08	000
9	1	CH9	09	09	000
10	1	CH10	10	10	000

Fig. 20.

1	1	CH1	01	01	000
---	---	-----	----	----	-----

Fig. 21.

1	1	CH1	01	01	000
---	---	-----	----	----	-----

Fig. 22.

MANUAL PROGRAMME PRESET

If you have made a mistake
Press ← to go back to the previous position.

To go back to main menu
Keep pressing ←.

To go back to the normal TV picture
Press MENU.

MANUAL PROGRAMME PRESET

Manual Fine-Tuning

Normally, the AFT (automatic fine-tuning) is already operating. However, if the picture is distorted, you can use the manual fine-tuning function to obtain better picture reception.

- 1 Press MENU to display the main menu.
- 2 Select »Preset« with Δ + or ▽ - and press OK. The PRESET menu appears.
- 3 Select »Manual Programme Preset« with Δ + or ▽ - and press OK. The MANUAL PROGRAMME PRESET menu appears. (See Fig. 23.)
- 4 Using Δ + or ▽ -, select the programme position corresponding to the channel which you want to manually fine-tune, and press OK repeatedly until the AFT position changes colour.
- 5 Fine-tune the channel with Δ + or ▽ - so that you get the best TV reception. As you press the cursor buttons, the frequency changes from -15 to +15. (See Fig. 24.)
- 6 After fine-tuning, press OK. The cursor appears beside the next programme position (at the left margin). (See Fig. 25.) Now the line-tuned level is stored.
- 7 Repeat steps 4 to 6 to fine-tune other channels.

PROG	SYS	CH	SEARCH	LABEL	AFT
1	1	CH1	01	01	000
2	1	CH2	02	02	000
3	1	CH3	03	03	000
4	1	CH4	04	04	000
5	1	CH5	05	05	000
6	1	CH6	06	06	000
7	1	CH7	07	07	000
8	1	CH8	08	08	000
9	1	CH9	09	09	000
10	1	CH10	10	10	000

Fig. 24.

2	1	CH2	02	02	000
---	---	-----	----	----	-----

Fig. 25.

1	1	CH1	01	01	000
---	---	-----	----	----	-----

Fig. 26.

PARENTAL LOCK

Parental Lock

You can prevent undesirable broadcasts from appearing on the screen. We suggest you use this function to prevent children from watching programmes which you consider unsuitable.

- 1 Press MENU to display the main menu.
- 2 Select »Preset« with Δ + or ▽ - and press OK. The PRESET menu appears.
- 3 Select »Parental Lock« with Δ + or ▽ - and press OK. The PARENTAL LOCK menu appears. (See Fig. 26.)
- 4 Using Δ + or ▽ -, select the programme position you want to block and press OK. The selected PROG number, CH and LABEL change colour indicating that this programme is now blocked. (See Fig. 27.)
- 5 Repeat step 4 to block other programme positions.

PROG	CH	LABEL	PROG	CH	LABEL
1	001	001	1	001	001
2	002	002	2	002	002
3	003	003	3	003	003
4	004	004	4	004	004
5	005	005	5	005	005
6	006	006	6	006	006
7	007	007	7	007	007

Fig. 26.

PROG	CH	LABEL	PROG	CH	LABEL
1	001	001	1	001	001
2	002	002	2	002	002
3	003	003	3	003	003

Fig. 27.

Cancelling blocking

- 1 On the PARENTAL LOCK menu, select the programme position you want to unblock with Δ + or ▽ -.
- 2 Press OK. The selected PROG number, CH and LABEL change colour to normal colour indicating that the blocking has been cancelled.

If you try to select a programme that has been blocked
The message «-LOCKED-» appears on the blank TV screen.

operation Instructions

1-4. WATCHING THE TV

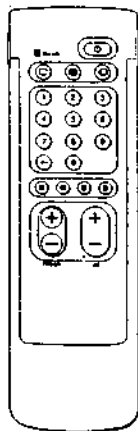

If no picture appears when you depress \odot on the TV and if the standby indicator on the TV is lit, the TV is in standby mode. Press \square or one of the number buttons to switch it on.

This section explains the basic functions you use while watching TV. Most of the operations can be done using the simple side of the Remote Commander.

Switching the TV on and off

Switching on

Depress \odot on the TV.

Switching off temporarily

Press \odot on the Remote Commander.

The TV enters standby mode and the standby indicator on the front of the TV lights up.

To switch on again:

Press \square , **PROGR +/-**, or one of the number buttons on the Remote Commander.

Switching off completely

Depress \odot on the TV.

Selecting TV Programmes

Press **PROGR +/-** or press number buttons.

To select a double-digit number

Press **-/-**, then the numbers.

For example, if you want to choose 23, press **-/-**, 2 and 3.

Adjusting the Volume

Press Δ **+/-**.

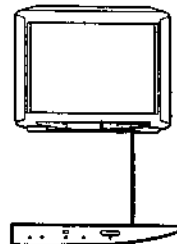

For details of the teletext operation, refer to page 18.

For details of the video input picture, refer to page 22.

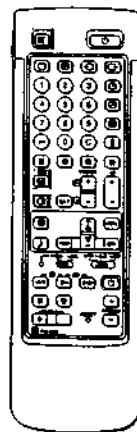

Operating the TV Using the Buttons on the TV

With the buttons on the TV, you can select programmes, adjust the volume, and select video input sources.

- Press **P** Δ \rightarrow \rightarrow \odot button repeatedly until the programme number, Δ (for volume), or \odot (for video input picture) appears. Then adjust with the **+/-** buttons.
- Press **-/+** buttons to switch on the TV from the standby mode.
- Press **-/+** simultaneously to reset picture and sound controls to the factory preset level (RESET function).

Watching Teletext or Video Input

Watching teletext

- Press \odot to view the teletext.
- Press three number buttons to select a page.
- Press one of the coloured buttons for fasttext operation.
- Press \ominus (PAGE +) or \oplus (PAGE -) for the next or preceding page.
- To go back to the normal TV picture, press \square .

Watching a video input picture

Press \odot repeatedly until the desired video input appears. To go back to the normal TV picture, press \square .

More Convenient Functions

Use the Full-Function side of the Remote Commander.

Displaying the on screen indications

- Press \square once to display all the indications. They will disappear after some seconds.
- Press \square twice to have the programme number and label stay on screen. Press twice again to make indications disappear.

Muting the sound

- Press \llcorner .
- To resume normal sound, press \llcorner again.

Displaying the time

- Press \odot . This function is available only when teletext is broadcast.
- To make the time display disappear, press \odot again.

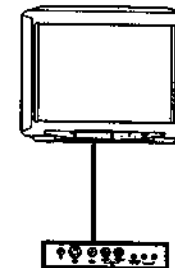

1-5. ADJUSTING AND SETTING THE TV USING THE MENU

PICTURE CONTROL SOUND CONTROL

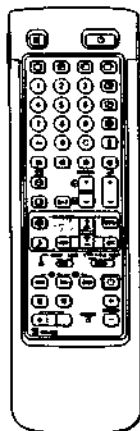

Adjusting the Picture and Sound

Although the picture and sound are adjusted at the factory, you can adjust them to suit your own taste. In addition, you can change the aspect ratio of the TV display for wide screen effect, or set the resolution to obtain a higher quality picture. You can also select dual sound (bilingual) programmes when available or adjust the sound for listening with the headphones.

- 1 Press **MENU** (for picture) or **SOUND** (for sound) on the Remote Commander.

or

Press **MENU** and select "Picture Control" or "Sound Control", then press **OK**.
The PICTURE CONTROL or SOUND CONTROL menu appears. (See Fig. 28 or Fig. 29.)

- 2 Using Δ + or ∇ -, select the item you want to adjust and press **OK**. The selected item changes colour. (See Fig. 30.)
- 3 Adjust the setting with Δ + or ∇ - and press **OK**. The cursor appears beside the next item (at the left margin). (See Fig. 31.)
For the effect of each control, see the table below.
- 4 Repeat steps 2 and 3 to adjust other items.

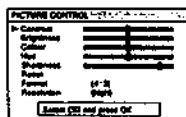

Fig. 28.

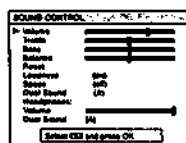

Fig. 29.

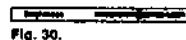

Fig. 30.



Fig. 31.

Effect of each control

PICTURE CONTROL	Effect
Contrast	Less \longleftarrow \longrightarrow More
Brightness	Darker \longleftarrow \longrightarrow Brighter
Colour	Less \longleftarrow \longrightarrow More
Hue	Greenish \longleftarrow \longrightarrow Reddish
Sharpness	Softer \longleftarrow \longrightarrow Sharper
Reset	Resets picture to the factory preset levels
Format	4:3: Normal 16:9: Wide screen effect
Resolution	Normal High: Obtain a higher quality picture

SOUND CONTROL	Effect
Volume	Less \longleftarrow \longrightarrow More
Treble	Less \longleftarrow \longrightarrow More
Bass	Less \longleftarrow \longrightarrow More
Balance	None left \longleftarrow \longrightarrow More right
Reset	Resets sound to the factory preset levels
Loudness	off: Normal on: When listening to low volume sound
Space	off: Normal on: Obtain acoustic sound effect
Dual Sound	A: left channel B: right channel stereo mono The selected mode of the A-C-D-B indicator on the TV lights up (for NICAM broadcasts see next page)
Headphones	
Volume	Less \longleftarrow \longrightarrow More
Dual Sound	A: left channel B: right channel stereo mono

If you have made a mistake
Press \leftarrow to go back to the previous position.

To go back to the main menu
Keep pressing \leftarrow .

To go back to the normal TV picture
Press **MENU**.

Note:
HUE is only available for NTSC colour system and RESOLUTION does not work for SECAM colour system.

Note on LINE OUT
The auto level and the dual sound mode output from the G-jack on the rear correspond to the Headphone VOLUME and DUAL SOUND settings.

When watching stereo, head & centre, SOUND to ch. the screen.

Selecting Nicam Broadcasts*

This Sony TV has been designed to select Nicam broadcasts when available. Whenever a Nicam broadcast is received, "NICAM" appears briefly on the screen. When the Nicam programme ends, or you switch channels to one without Nicam, the A-C-D-B indicators, on the TV will switch off.

Nicam programmes can be broadcast in two ways. You may select the sound you want to hear in either of these by first following the instructions explained on page 16.

Service Being Broadcast	Action	Effect	Indication on the TV A-C-D-B
Stereo	Press Δ + or ∇ -	Stereo Nicam (Mono 2-Channel) mono	A^* B^* C^* D^*
Press Δ + or ∇ - again to return to stereo Nicam (mono 2-channel)			
Bilingual	press Δ + or ∇ -	Channel A Nicam Channel B Nicam mono	A^* B^* C^* D^*
Press Δ + or ∇ - again to return to channel A Nicam			

* Depending on availability of service.

Using the Programme Table

On this table, you can see which channel is preset to which programme position. You can also select programmes using this table.

From the main menu, select "Programme Table" with Δ + or ∇ - and press **OK**. The PROGRAMME TABLE menu appears. (See Fig. 32.)

To scroll to higher programme numbers, press Δ -.

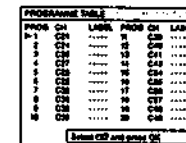

Fig. 32.

Using the Sleep Timer

You can select a time period after which the TV automatically switches into standby mode.

- 1 From the main menu, select "Timer" with Δ + or ∇ - and press **OK**. The TIMER menu appears. (See Fig. 33.)
- 2 Press **OK**. The time period option changes colour.
- 3 Select the time period with Δ + or ∇ -. The time period (in minutes) changes as follows:
10 \rightarrow 20 \rightarrow 30 \rightarrow 40 \rightarrow 50 \rightarrow 60 \rightarrow 70 \rightarrow 80 \rightarrow 90
OFF
- 4 After selecting the time period, press **OK**. The cursor moves back to the left margin and the timer starts counting. One minute before the TV switches into standby mode, a message is displayed on the screen.

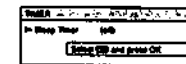
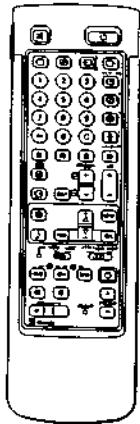

Fig. 33.

1-6. PIP (PICTURE-IN-PICTURE)



Note
RGB input source
cannot be displayed
in PIP.

With this function you can display a "PIP screen" (small picture) within the main TV picture. In this way you can watch or monitor the video output from any connected equipment (for example from a VTR) while watching TV or vice versa. For information about connection of other equipment, refer to page 21.

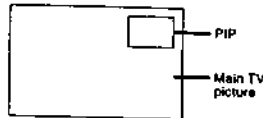

Switching PIP on and off

Press **Q**.

The PIP screen will be displayed. The PIP picture will come from the source chosen when the TV was last used.

To switch PIP off

Press **Q** again.

Selecting a PIP source

Press **I**.

The symbol **I** will be displayed at the bottom, left-hand corner of the screen.

Press **Q** repeatedly until the desired source is indicated (e.g. TV, AV 1, AV 2, YC2, AV 3, YC3, AV 4, YC4).

Note

If no video source has been connected, the PIP picture will be noisy.

Swapping screens

Press **Q**.

The main screen will switch the picture with the PIP screen.

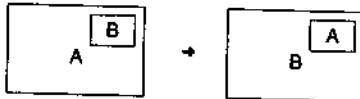

Note

If a TV programme is on the PIP screen and a video source on the main picture, and you want to change channels, first press **I** and then the programme buttons or **PROGR** \leftarrow .

Changing the position of the PIP

Press **@** repeatedly to change the position of the PIP screen within the main screen. There are four different positions available.

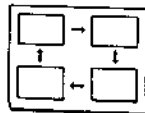

1-7. TELETEXT

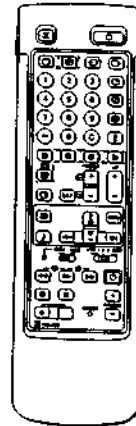

Note
Teletext errors may occur if the broadcasting signals are weak.

With the simple side of the Remote Commander

You can switch teletext on and off, operate Fastext, and directly select page numbers.

Note

Fastext operation is only possible, if the TV station broadcasts Fastext signals.

TV stations broadcast an information service called Teletext via the TV channels. Teletext service allows you to receive various information pages such as weather reports or news at any time you want. For advanced teletext operation, use the buttons on the Full-Function side of the Remote Commander.

Direct Access Functions

Switching Teletext on and off

1 Select the TV channel which carries the teletext broadcast you want to watch.

2 Press **@** to switch on teletext.

A teletext page will be displayed (usually the index page).

If there is no teletext broadcast, "No text available" is displayed on the information line of the screen.

To switch teletext off

Press **Q**.

Selecting a teletext page

With direct page selection

Use the number buttons to input the three digits of the chosen page number.

If you have made a mistake, type in any three digits. Then re-enter the correct page number.

With page-catching

1 Select a teletext page with a page overview (e.g. index page).

2 Press **@** twice. "Page catching" will be displayed on the information line. The last digit of the first displayed page number flashes.

3 Using Δ + ∇ , select the desired page and press **OK**. The requested page will appear in a few seconds.

Accessing next or preceding page

Press **@** (PAGE +) or **@** (PAGE -).

The next or preceding page appears.

Superimposing the teletext display on the TV programme

• Press **@** once in teletext mode or twice in TV mode.

• Press **@** again to resume normal teletext reception.

Preventing a teletext page from being updated

• Press **@** (HOLD). The HOLD symbol -@- is displayed on the information line.

• Press **@** to resume normal teletext reception.

Using Fastext

With Fastext you can access pages with one key stroke.

When a Fastext page is broadcast, a colour-coded menu will appear at the bottom of the screen. The colours of this menu correspond to the red, green, yellow and blue buttons on the Remote Commander.

Press the corresponding coloured button on the Remote Commander which corresponds to the colour-coded menu. The page will be displayed after some seconds.

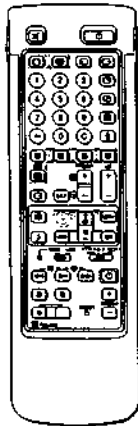

Note
Some of the features
may not be available
depending on the
Teletext service.

Using the Teletext Menu

This TV is provided with a menu-guided teletext system. When teletext is switched in, you can use the menu buttons to operate the teletext menu. Select the teletext menu functions in the following way:

- 1 Press MENU. The menu will be superimposed on the teletext display. (See Fig. 34.)
- 2 Using Δ + ∇ -, select the teletext function you want and press OK. (See Fig. 35.)

USER PAGES/PRESET USER PAGES

See page 20 for information about presetting and operating the user pages.

INDEX

The index will give you an overview of the contents of the teletext and the page numbers.

TOP/BOTTOM/FULL

For convenient reading of a teletext page, you can enlarge the teletext display. After having selected the function, an information line TOP/BOTTOM/FULL will be displayed. (See Fig. 36.)

Press Δ + \rightarrow "Top" to enlarge the upper half, ∇ - for "Bottom" to enlarge the lower one and OK for "Full" to resume the normal size.

Press OK to resume normal teletext reception.

TEXT CLEAR

After having selected the function, you can watch a TV programme while waiting for a teletext page to be displayed. (See Fig. 37.)

Press OK to resume normal teletext mode.

REVEAL

Sometimes pages contain concealed information, such as answers to a quiz. The reveal option lets you disclose the information. After having selected the function, an information line "REVEAL ON/OFF" will be displayed. (See Fig. 38.)

Using Δ + ∇ -, select ON to reveal the information or OFF to conceal it again.

Press OK to resume normal teletext reception.

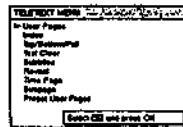

Fig. 34.

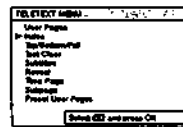

Fig. 35.

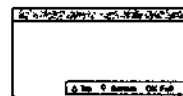

Fig. 36.



Fig. 37.



Fig. 38.

To cancel the request
Select "OFF" for the
SUBPAGE setting and
press OK.

If two broadcasting
stations use the
same Teletext
You can preset one
bank to 2 different
programme positions.

SUBPAGE

You may want to select a particular teletext page from several subpages which are rotated automatically. If you want to select one subpage, follow the operations below:

- 1 Using Δ + ∇ -, select ON for the SUBPAGE setting and press OK.
- 2 To select the desired subpage, enter four digits using PROG \rightarrow /- or the number buttons. (e.g. enter 0002 for the second page of a sequence).

User Page Bank System

You can store up to 30 pages in the "Teletext page bank system". In this way you have quick access to the pages you watch frequently.

Storing pages

There are 5 "banks" (A to E) for 5 teletext stations. In each bank you can store 6 preferred pages (1P to 6P).

- 1 Press OK (if Teletext is not on already) and MENU to show the TELETEXT MENU display.
- 2 Select PRESET USER PAGES with Δ + ∇ - and press OK.
- 3 Select the desired bank with Δ + ∇ - and press OK. The cursor will go to the first position (P1) of the preferred pages.
- 4 Input the three digits of your first preferred page with the number buttons and press OK. The cursor will go to the second position.
- 5 Repeat step 4 for the other 5 page numbers you want to preset. If you do not want to preset all 6 page numbers available, press OK without inserting any number.
- 6 Select "Allocate Bank" with Δ + ∇ - and press OK.
- 7 Select the programme position for which you have preset pages with Δ + ∇ - and press OK. (See Fig. 39).
- 8 Select the desired bank with Δ + ∇ - (Banks A to E are available) and press OK.
- 9 Repeat steps 3 to 8 for the other 4 banks available.

Displaying User Pages

- 1 Select MENU.
- 2 Select "USER PAGES" with Δ + ∇ - and press OK. A table of the stored preferred pages will be displayed. (See Fig. 40.)
- 3 Select the desired page with Δ + ∇ - and press OK. The page will be displayed after some seconds.

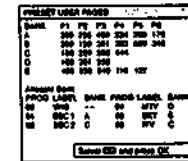

Fig. 39.



Fig. 40.

1-8. CONNECTING AND OPERATING OPTIONAL EQUIPMENT

Connecting Optional Equipment

You can connect optional audio-video equipment to this TV such as VTRs, video disc players, and stereo systems.

To connect a VTR using the **T** terminal
Connect the aerial output of the VTR to the aerial terminal **T** of the TV.
We recommend that you tune in the video signal to programme number **00**. For details see **Pre-set channels manually** on page 9.

If the picture or the sound is distorted
Move the VTR away from the TV.

Note:
After having connected all optional equipment to the TV, attach the supplied cover onto the rear panel (See illustration at the right).

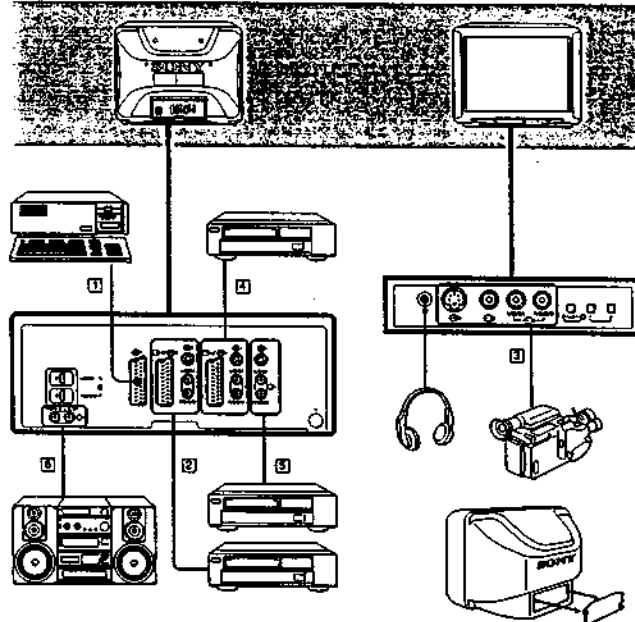

S video Input (Y/C input)
Video signals may be separated into Y (luminance or brightness) and C (chrominance) signals. Separating the Y and C signals prevents them from interfering with one another, and therefore improves picture quality (especially luminance).
This TV is equipped with 3 S Video input jacks through which these separated signals can be input directly.

When connecting a monaural VTR
Connect only the white **⊖** jack to both the TV and VTR.

Acceptable input signal	Available output signal
1 Normal audio/video and RGB signal	Video/audio from TV tuner
2 Normal audio/video and S video signal	Video/audio from selected source
3 Normal audio/video and S video signal	No outputs
4 Normal audio/video and S video signal	Video/audio displayed on TV screen (monitor out)
5 No inputs	S video/audio signal (displayed on TV screen (monitor out))
6 No inputs	Audio signal (variable)

Selecting input with **PROGR +/-** or number buttons
You can preset video input sources to the programme positions so that you can select them with **PROGR +/-** or number buttons. For details, see **Pre-set channels manually** on page 9.

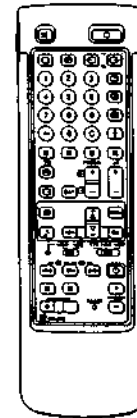

Selecting input and output

This section explains how to view the video input picture (of the video source connected to your TV), and how to select the output signal using direct access buttons or the menu system.

Selecting input

Press **⊖** repeatedly to select the input source.
The symbol of the selected input source will appear.

To go back to the normal TV picture

Press **⊖**.

Input modes

Symbol	Input signal
⊖ 1	Audio/video input through the ⊖ 1 connector
⊖ 2	RGB input through the ⊖ 1 connector
⊖ 2	Audio/video input through the ⊖ 2 / ⊖ 2 connector
⊖ 2	S video input through the ⊖ 2 / ⊖ 2 or ⊖ 2 connector
⊖ 3	Audio/video input through ⊖ 3 and ⊖ on the front
⊖ 3	S video input through the ⊖ 3 connectors on the front (4-pin connector)
⊖ 4	Audio/video input through the ⊖ 4 / ⊖ 4 connector
⊖ 4	S video input through the ⊖ 4 / ⊖ 4 or ⊖ 4 connector (4-pin connector)

You can also select the input mode using the **F**, **Δ**, **→**, **←** and **-/+** buttons on the TV.

In this case, first select **⊖**, and then press **-/+** buttons to select the input.

Selecting the output

The **⊖ 2 / ⊖ 2** connector outputs the source input from the other connectors.

Press **⊖** repeatedly to select the output.
The symbol of the selected output source appears.

Output modes

Symbol	⊖ 2 / ⊖ 2 connector outputs
1 ⊖	The audio/video signal from the ⊖ 1 connector
2 ⊖	The audio/video signal from the ⊖ 2 / ⊖ 2 connector
2 ⊖	The audio/S video signal from the ⊖ 2 / ⊖ 2 connector
3 ⊖	The audio/video signal from the ⊖ 3 and ⊖ 3 connectors
3 ⊖	The audio/S video signal from the ⊖ 3 and ⊖ 3 connectors
4 ⊖	The audio/video signal from the ⊖ 4 / ⊖ 4 connector
4 ⊖	The audio/S video signal from the ⊖ 4 / ⊖ 4 connector
TV ⊖	The audio/video signal from the T aerial terminal

Checking and selecting the input and output sources using the menu

You can display the menu to see which input sources are selected for the TV screen and PIP screen, and which output source is selected. You can also select them on the menu display.

- 1 Select «Video Connection» with $\Delta + \circ \nabla$ and press OK. The VIDEO CONNECTION menu appears. (See Fig. 41). You can see which source is selected for the TV and PIP input, and for the output. If you want to select the input and output on this menu, go on to the next step.
- 2 Select TV screen (input source for the TV screen), PIP (input source for the PIP screen), or Output (output source) with $\Delta + \circ \nabla$ and press OK. One of the source items changes colour. (See Fig. 42.)
- 3 Select the desired source with $\Delta + \circ \nabla$. (See Fig. 43.) For details about each source, see the table on page 22.
- 4 Press OK. The selected source is confirmed, and the cursor appears. (See Fig. 44.)
- 5 Repeat steps 2 to 4 to select the sources for other inputs or outputs.

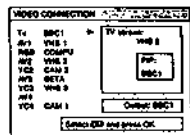

Fig. 41.



Fig. 42.

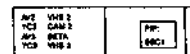

Fig. 43.

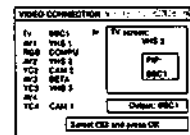
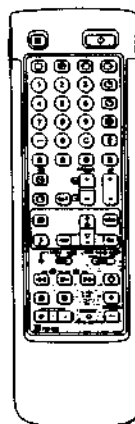

Fig. 44.



When recording
When you use the RECORD (record) button, make sure to press this button and the one to the right of it simultaneously.

- Do not move the Remote Commanders during programming.
- After programming, check to see if all the programmed functions work. It may be the case, that a function cannot be programmed.
- When you want to operate the audio or video equipment Make sure that the VTR 1/2/3 MDP selector is set to the position you used during programming.
- When you replace the Remote Commander batteries, the programmed functions remain stored for 30 minutes without a battery.
- When the memory of the programmable Remote Commander is full, the MEM indicator lights up.

Remote Control of Other Equipment

You can use the TV Remote Commander to control other remote-controlled equipment. The buttons for video operation have been factory-set to control most of Sony video equipment, such as: Beta, 8mm or VHS VTRs or video disc players. Additionally you can programme these buttons to control also audio and video equipment of other manufacturers.

Tuning the Remote Commander to Sony equipment

- 1 Set the VTR 1/2/3 MDP selector according to the equipment you want to control:
VTR 1: Beta or ED Beta VTR
VTR 2: 8mm VTR
VTR 3: VHS VTR
MDP: Video disc player
- 2 Use the buttons indicated in the illustration to operate the additional equipment. If your video equipment is furnished with a COMMAND MODE selector set this selector to the same position as the VTR 1/2/3 MDP selector on the TV Remote Commander. If the equipment does not have a certain function, the corresponding button on the Remote Commander will not operate.

Tuning the Remote Commander to audio or video equipment of other manufacturers

Your TV Remote Commander is a programmable Remote Commander. This means that you can programme the buttons indicated in the illustration with functions of other Remote Commanders. A function can be stored on any of the buttons and on all four levels of the VTR 1/2/3 MDP selector.

Programming a function

- 1 Set the MEM/USE switch to MEM (memorize).
- 2 Set the VTR 1/2/3 MDP selector to the desired position.
- 3 Position the two Commanders head to head (see illustration).
- 4 First press the button on the TV Remote Commander onto which you want to programme a function. Now the MEM indicator on the Remote Commander lights up.
- 5 Then press the button on the other Remote Commander, the function of which you want to programme. As soon as the MEM indicator goes out, the function is stored.
- 6 Repeat steps 4 and 5 for all other functions you want to programme. When you have programmed all buttons on one level of the VTR 1/2/3 MDP selector, select another level.
- 7 When you have finished programming, set the MEM/USE switch to USE.

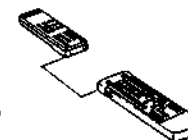

Clearing programmed functions

- 1 Set the MEM/USE switch to MEM.
- 2 Set the VTR 1/2/3 selector to the level of functions you want to clear.
- 3 Press any of the programmable buttons. Now the MEM indicator lights up.
- 4 Keep the RESET button pressed, using the tip of a pen, until the MEM indicator has flashed four times. Now all programmed functions on this level are cleared.
- 5 Reset the MEM/USE switch to USE.

1-9. FOR YOUR INFORMATION

Troubleshooting

Here are some simple solutions to problems which may affect the picture and sound.

Problem	Solution
No picture (screen is dark), no sound	<ul style="list-style-type: none"> • Plug the TV in. • Press 0 on the TV. (If 0 indicator is on, press 0 or a programme number on the Remote Commander.) • Check the aerial connection. • Check if the selected video source is on. • Turn the TV off for 3 or 4 seconds and then turn it on again using 0.
Poor or no picture (screen is dark), but good sound	<ul style="list-style-type: none"> • Press 1 to enter the PICTURE CONTROL menu and adjust «Brightness», «Contrast» and «Colour».
Good picture but no sound	<ul style="list-style-type: none"> • Press 3 + +. • If 4K is displayed on the screen, press 4K.
No colour for colour programmes	<ul style="list-style-type: none"> • Press 1 to enter the PICTURE CONTROL menu, select «Reset», then press OK.
Remote Commander does not function	<ul style="list-style-type: none"> • The batteries are weak. • Set the MEM/USE switch to USE.

If you continue to have problems, have your TV serviced by qualified personnel. Never open the casing yourself.

Television Channel Number Guide

Only the main transmitters are listed. Information regarding the regional sub-relay channel numbers can be obtained by contacting The BBC Engineering Information Dept. (081) 752 5040.

MAIN TRANSMITTERS	BBC1	BBC2	ITV	CH4
London & South East				
Bluebell Hill	40	46	43	65
Crystal Palace	26	33	23	30
Dover	50	56	66	53
Heathfield	49	52	64	67
Oxford	57	63	60	53
South-West				
Beacon Hill	57	63	60	53
Caradon Hill	22	28	25	32
Hunishaw Cross	55	62	59	65
Redruth	51	44	41	47
Stockland Hill	33	26	23	29
Channel Islands				
Fremont Point	51	44	41	47
South				
Hannington	39	45	42	68
Midhurst	61	55	58	68
Rowridge	31	24	27	21
West				
Mendip	58	64	61	54
East				
Sandy Heath	31	27	24	21
Sudbury	51	44	41	47
Tacoineson	62	55	59	65
Midlands				
Ridge Hill	22	28	25	32
Sutton Coldfield	46	40	43	50
The Wrekin	26	33	23	29
Wakham	56	64	61	54
Northern Ireland				
Brougher Mountain	22	28	25	32
Divis	31	27	24	21
Limavady	55	62	59	65
North				
Belmont	22	29	25	32
Emley Moor	44	51	47	41
North-West				
Winter Hill	55	62	59	65
Douglas (IOM)	68	66	46	56
North-East				
Bilsdale West Moor	33	26	29	23
Caldbeck	30	34	28	32
Chalton	39	45	49	42
Ponkop Pike	56	64	61	54
Laxey (IOM)	58	64	61	54
Scotland				
Angus	57	63	60	53
Black Hill	40	46	43	50
Sandale	22	-	-	-
Caldbeck	-	34	28	32
Craigkelly	31	27	24	21
Darvel	33	26	23	29
Durris	22	28	25	32
Eilshaf	33	26	23	29
Keelhang Hill	40	46	43	50
Knock More	33	26	23	29
Rosemarkie	39	45	49	42
Rumster Forest	31	27	24	21
Selkirk	55	62	59	65
Wales				
Blaenphwyf	31	27	24	21
Carmel	57	63	60	53
Llanddona	57	63	60	53
Maely-Parc	52	45	49	42
Presely	46	40	43	50
Wenvoe	44	51	41	47

SECTION 2 DISASSEMBLY

2-1. REAR COVER REMOVAL

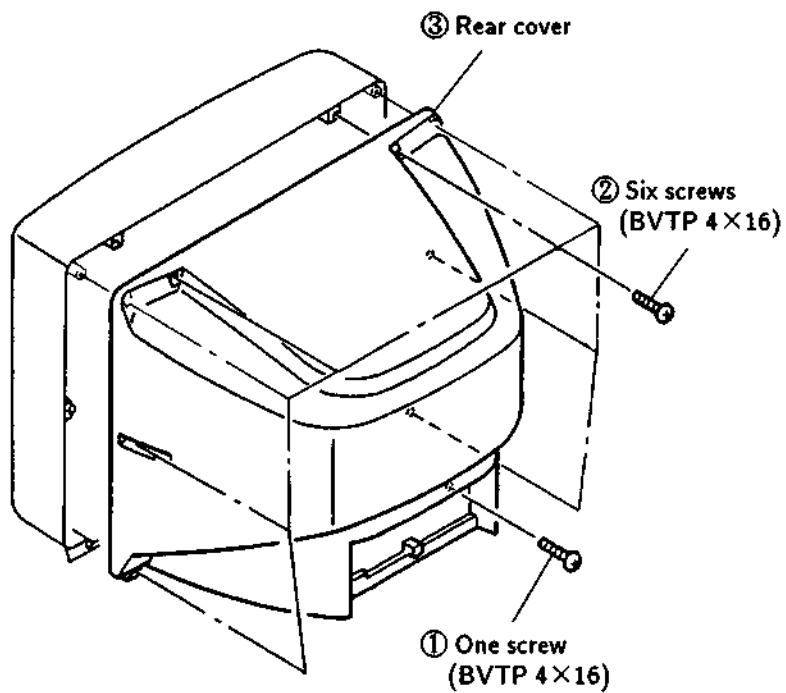

2-2. SPEAKER REMOVAL

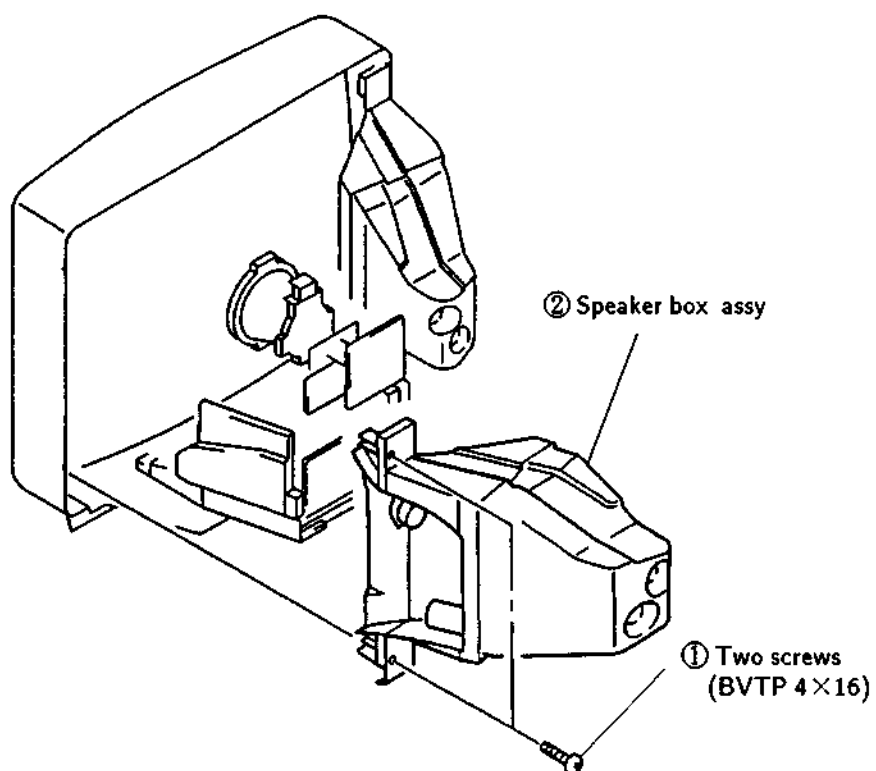

2-3. CHASSIS ASSY REMOVAL

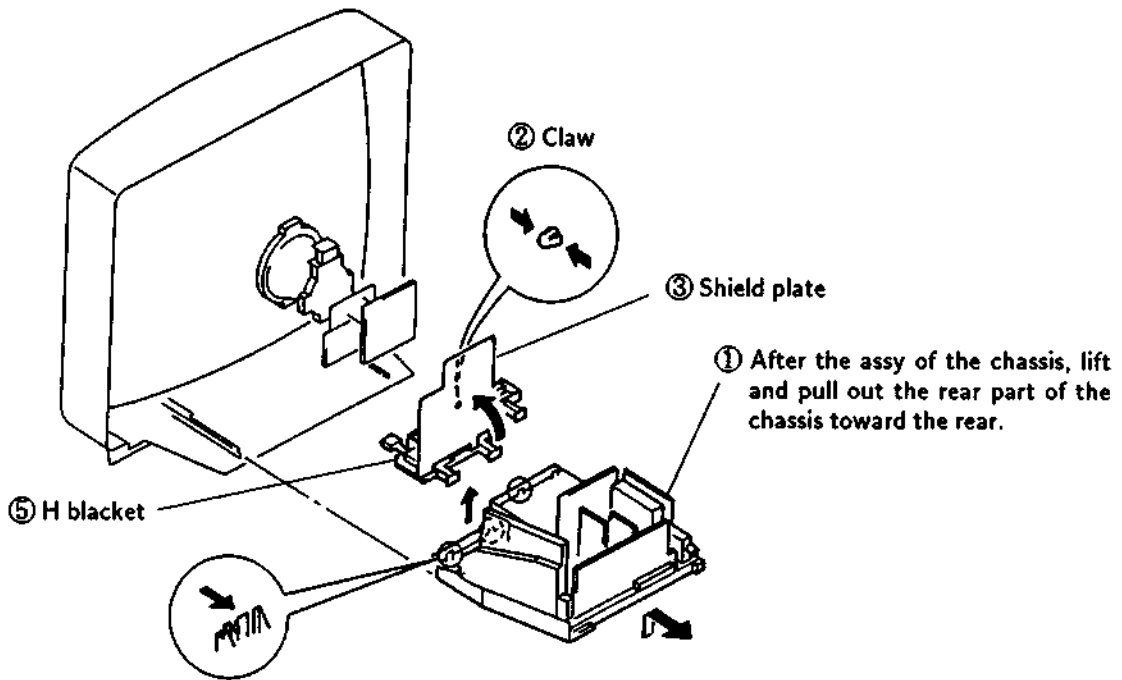

④ Push the three claws of the chassis in the direction of the arrow and remove the H bracket upwards.

2-4. SERVICE POSITION

- ※ Remove the H bracket from the chassis assy and then perform the following servicing.
(Refer to 2-3. CHASSIS ASSY REMOVAL)

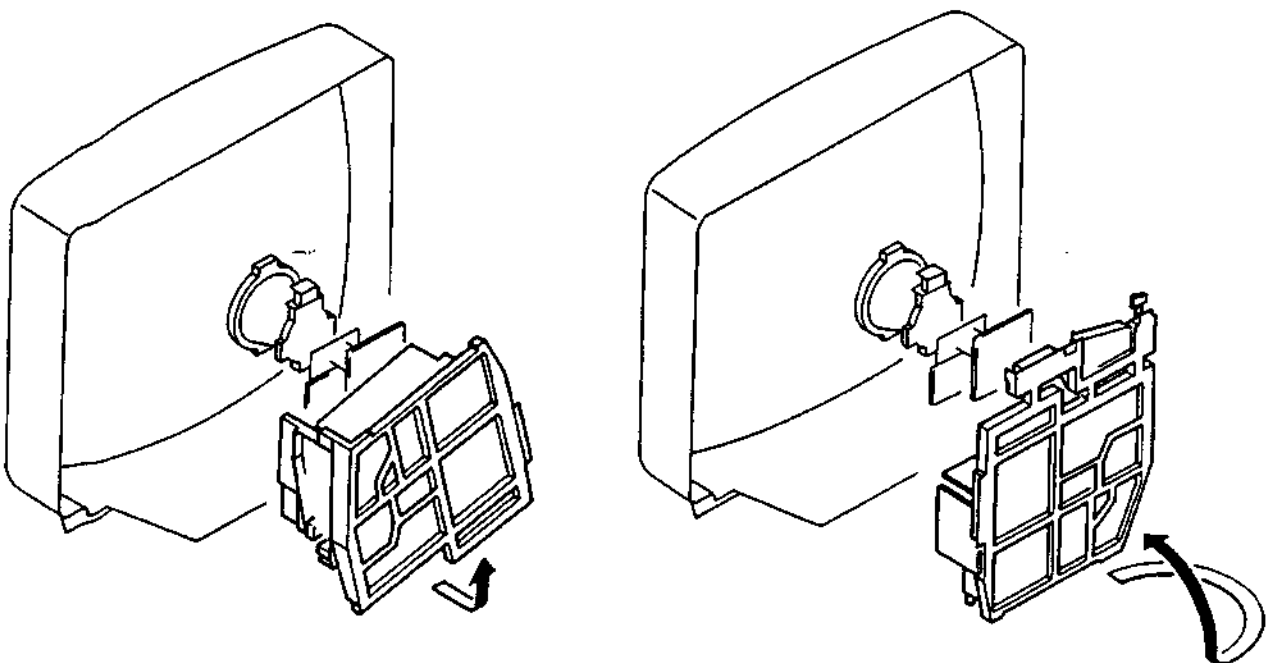

2-5. M, V AND A 1 BOARDS REMOVAL

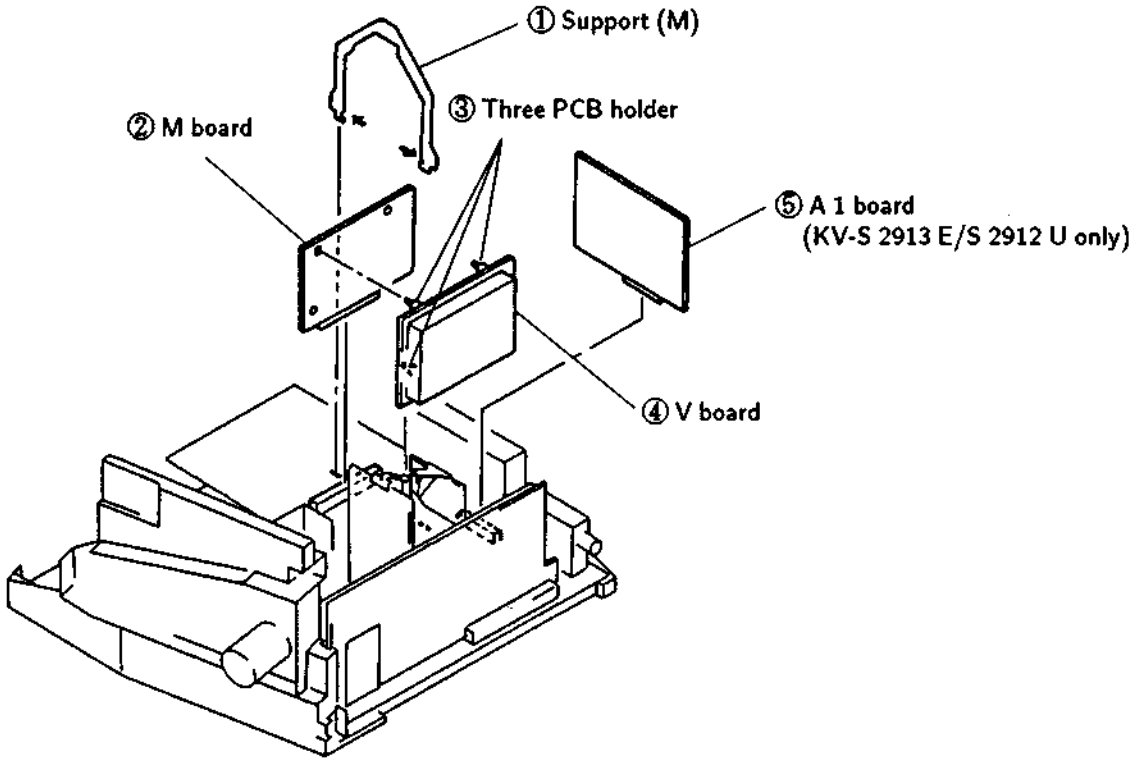

2-6. D 2 AND B 1 BOARDS REMOVAL

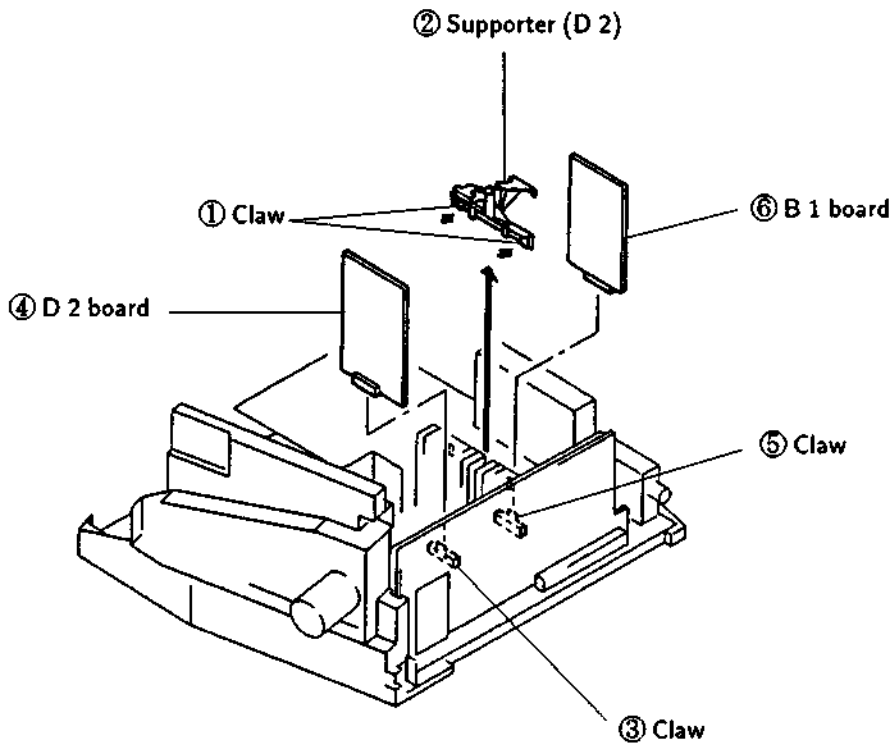

2-7. EXTENSION BOARD

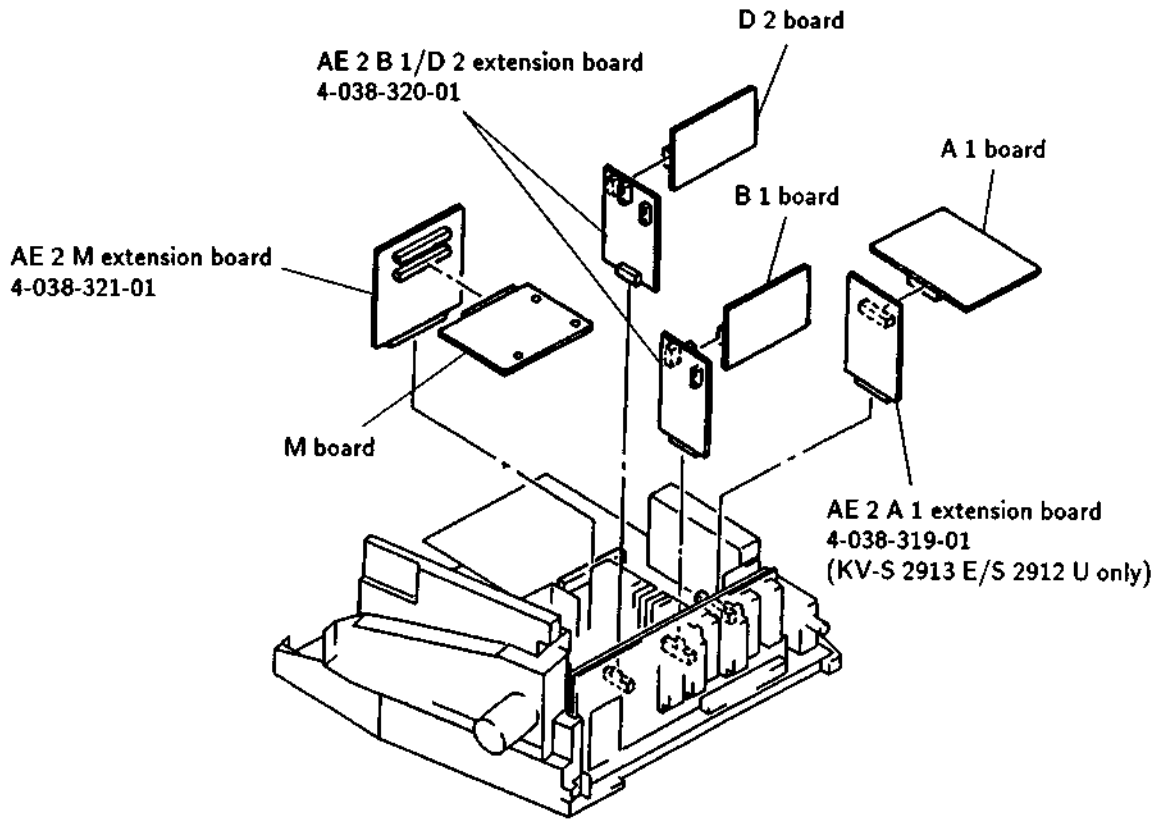

2-8. F BRACKET REMOVAL

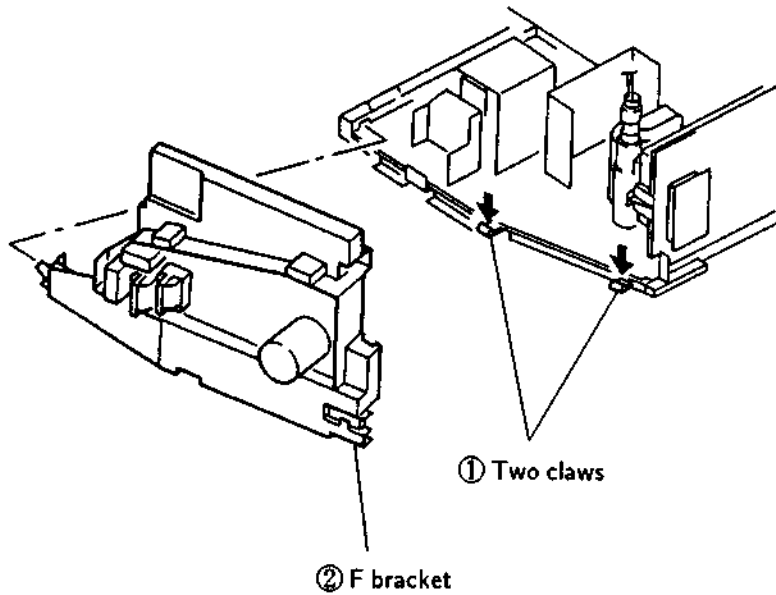

2-9. J BOARD REMOVAL

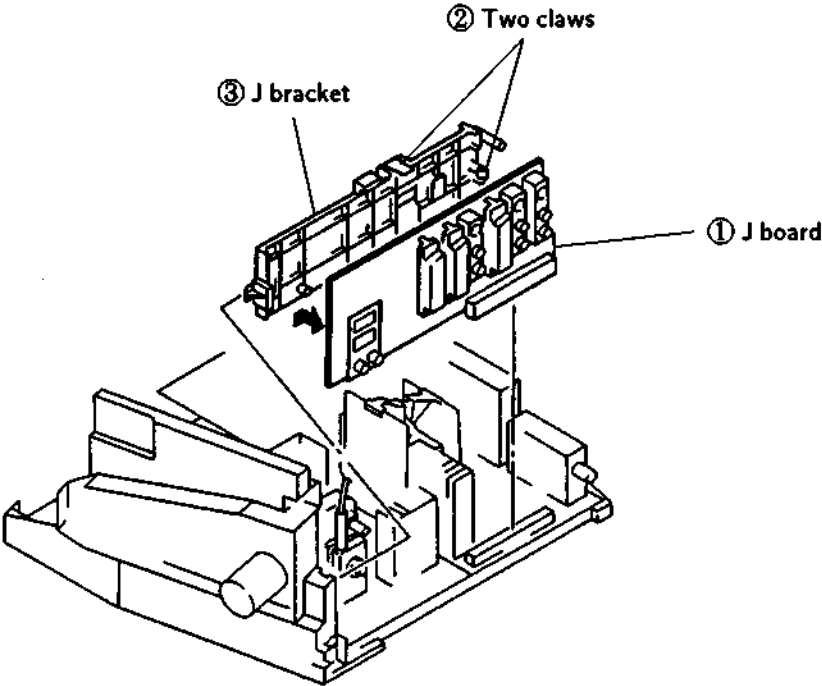

2-10. P BOARD REMOVAL

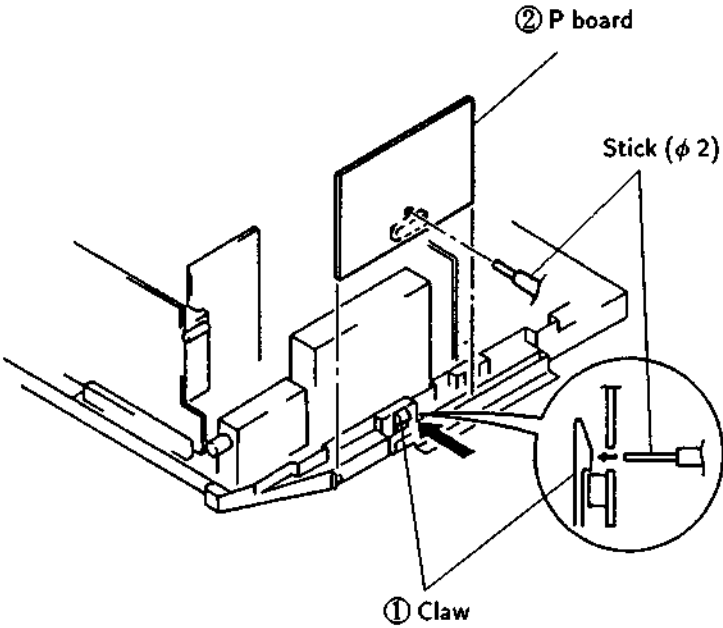

2-11-1. WIRE ROD

※ Keep distance between ① and ②

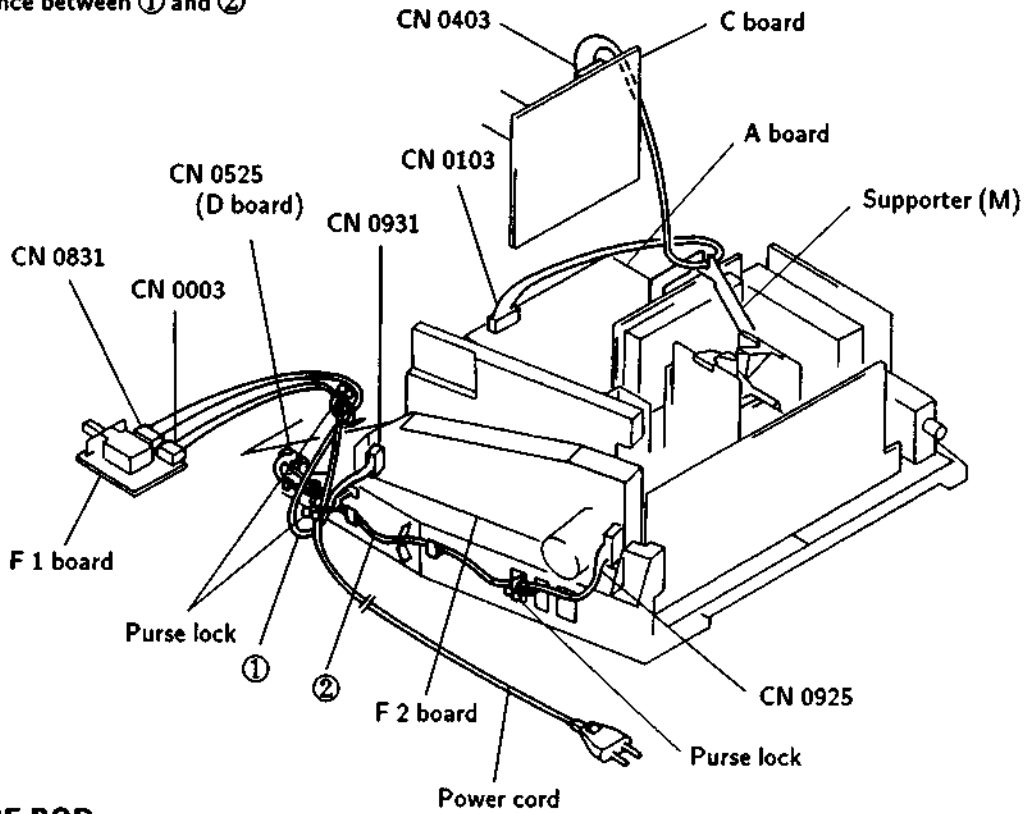

2-11-2. WIRE ROD

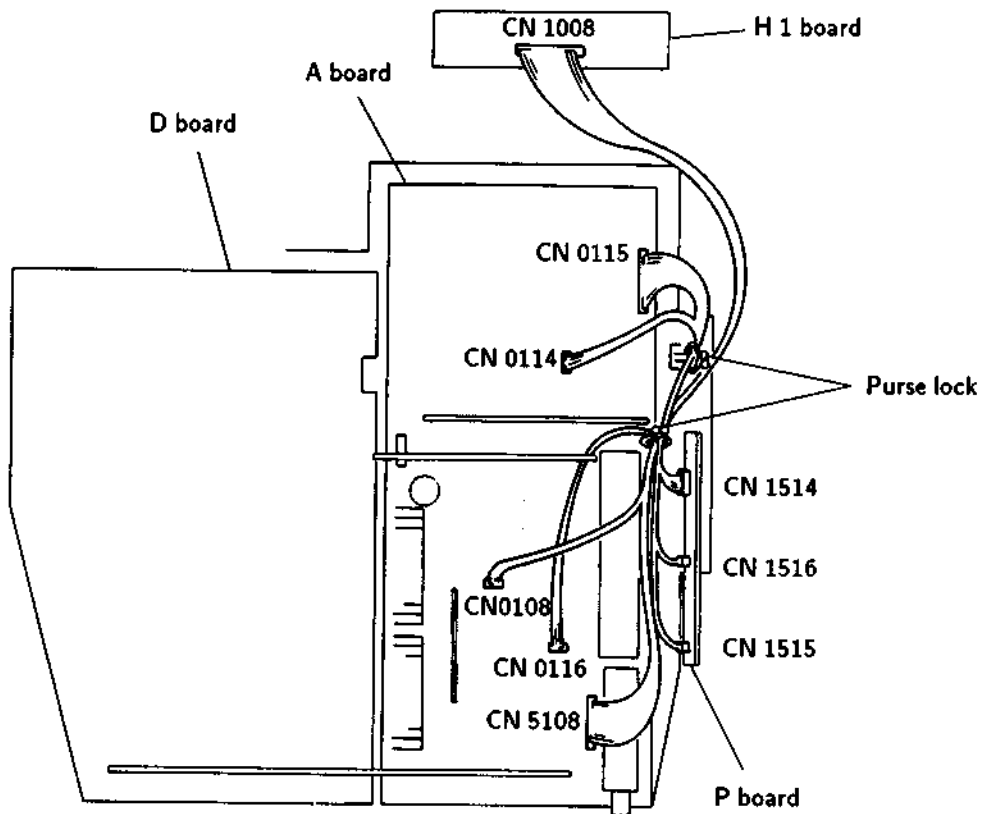

2-12. DEGAUSSING COIL REMOVAL

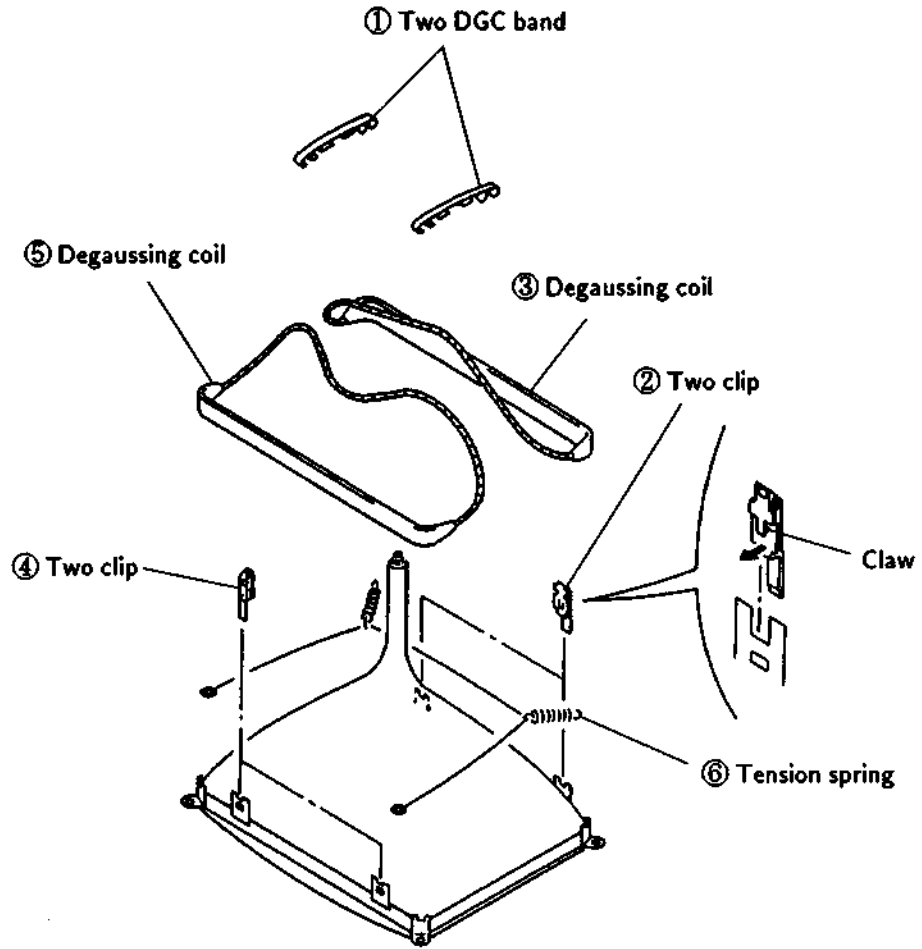

2-13. PICTURE TUBE REMOVAL

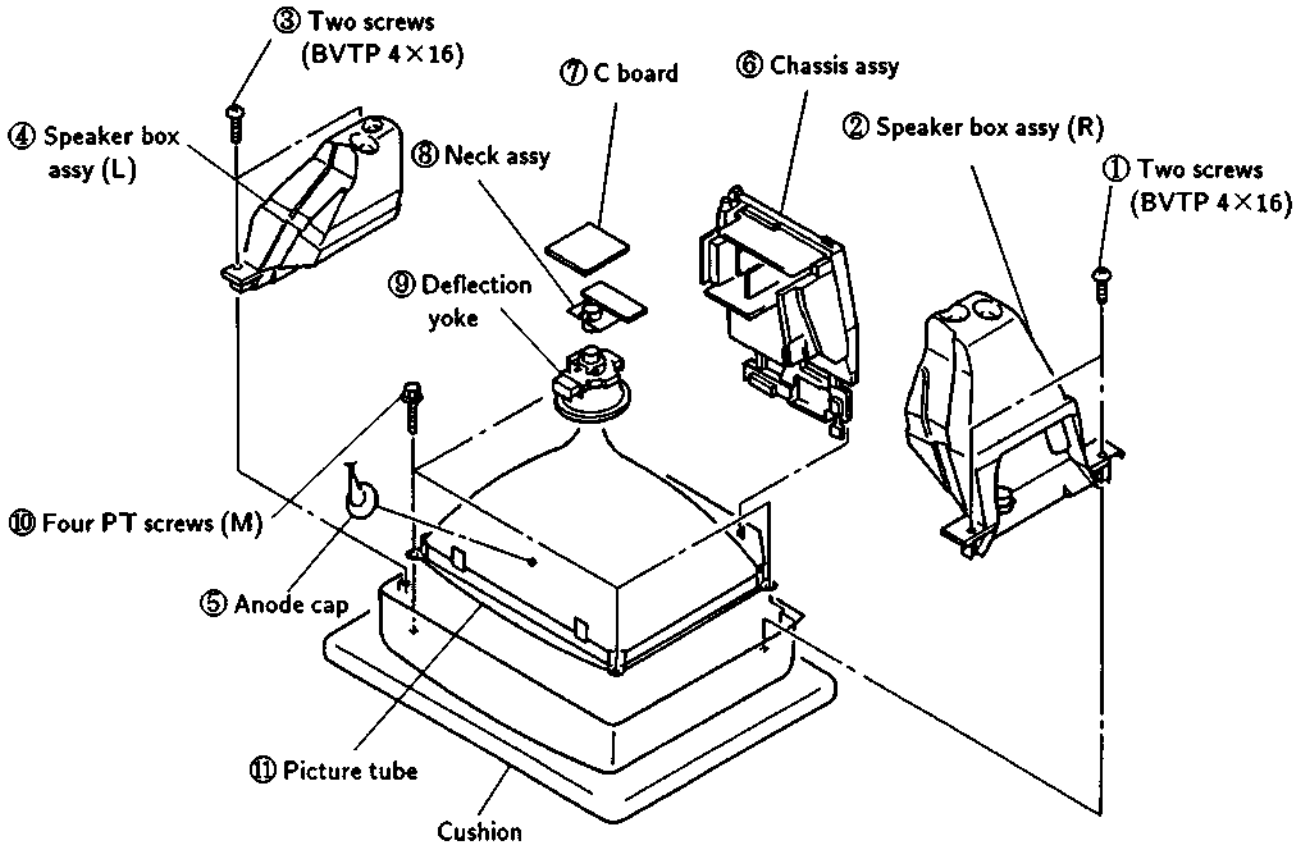

• REMOVAL OF ANODE-CAP

NOTE : Short circuit the anode of the picture tube and the anode cap to the metal chassis, CRT shield or carbon painted on the CRT, after removing the anode.

• REMOVING PROCEDURES

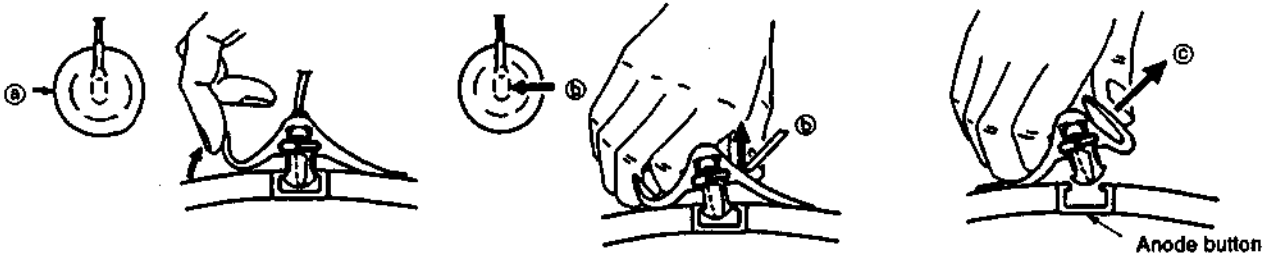

① Turn up one side of the rubber cap in the direction indicated by the arrow ①.

② Using a thumb pull up the rubber cap firmly in the direction indicated by the arrow ②.

③ When one side of the rubber cap is separated from the anode button, the anode-cap can be removed by turning up the rubber cap and pulling up it in the direction of the arrow ③.

• HOW TO HANDLE AN ANODE-CAP

- ① Don't hurt the surface of anode-caps with sharp shaped material!
- ② Don't press the rubber hardly not to hurt inside of anode-caps!
A material fitting called as shatter-hook terminal is built in the rubber.
- ③ Don't turn the foot of rubber over hardly!
The shatter-hook terminal will stick out or hurt the rubber.

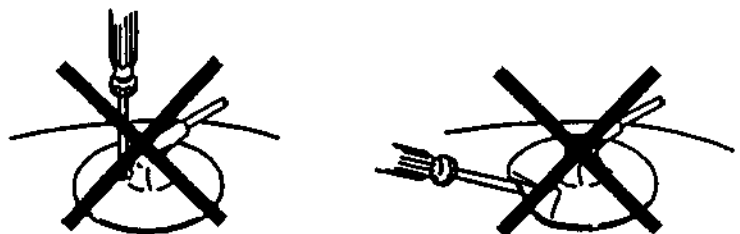

SECTION 3 SET-UP ADJUSTMENTS

- When complete readjustment is necessary or a new picture tube is installed, carry out the following adjustments.
- Unless there is specific instruction to the contrary, carry out these adjustments with the rated power supply.
- Unless there is specific instruction to the contrary, set the controls and switches this way :

● Contrast 80% (or remote control normal)

⚙ Brightness 50%

Preparations :

- In order to reduce the influence of geomagnetism on the set's picture tube face it east or west.
- Switch on the set's power and degauss with the degausser.

3-1. BEAM LANDING

1. Input the white signal with the pattern generator.

Contrast	}	normal
Brightness		
2. Position neck assy as shown in Fig.3-2.
3. Set the pattern generator raster signal to red.
4. Move the deflection yoke to the rear and adjust with the purity control so that the red is at the center and the blue and the green take up equally sized areas on each side. (See Fig.3-1 - 3-3)
5. Move the deflection yoke forward and adjust so that entire screen is red. (See Fig.3-1)
6. Switch the raster signal to blue, then to green and verify the condition.
7. When the position of the deflection yoke has been decided, fasten the deflection yoke with the screws.
8. If the beam does not land correctly in all the corners, use a magnet to adjust it. (See Fig.3-4)

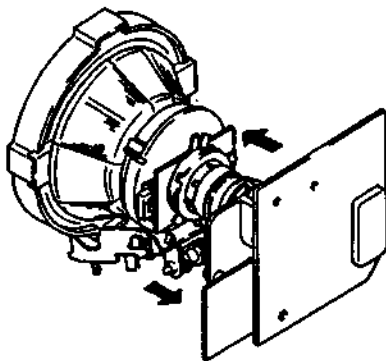

Fig.3-1

- Carry out the following adjustments in this order :

1. Beam landing
2. Convergence
3. Focus
4. White balance

Note: Testing equipment required.

1. Color bar/pattern generator
2. Degausser
3. DC power supply
4. Digital multimeter
5. Oscilloscope

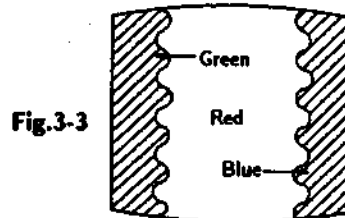
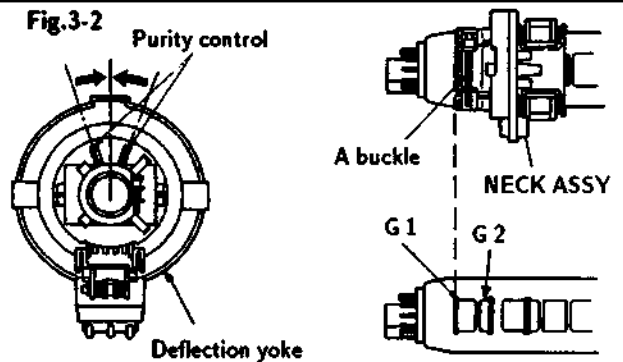

Fig.3-3

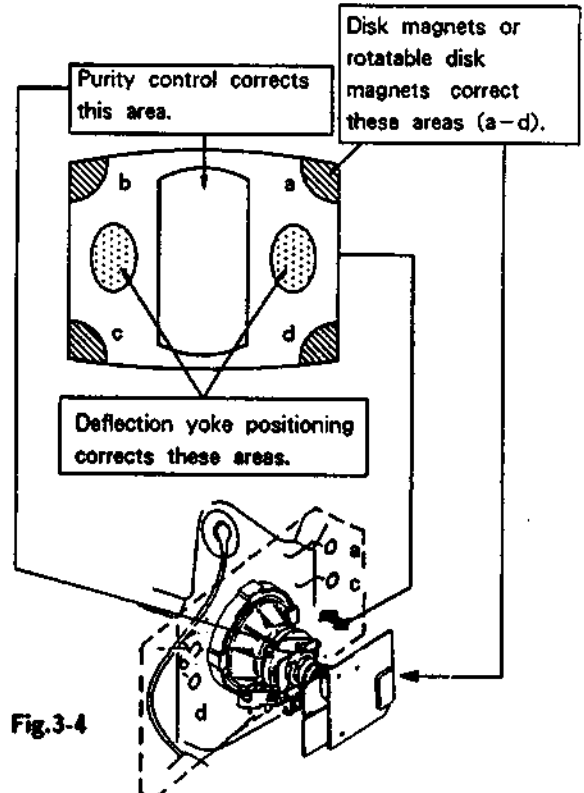

Fig.3-4

3-2. CONVERGENCE

Preparations :

- Before starting this adjustment, adjust the focus, horizontal size, and vertical size.
- Minimize the brightness setting.
- Provide dot pattern.

(1) Horizontal and vertical static convergence

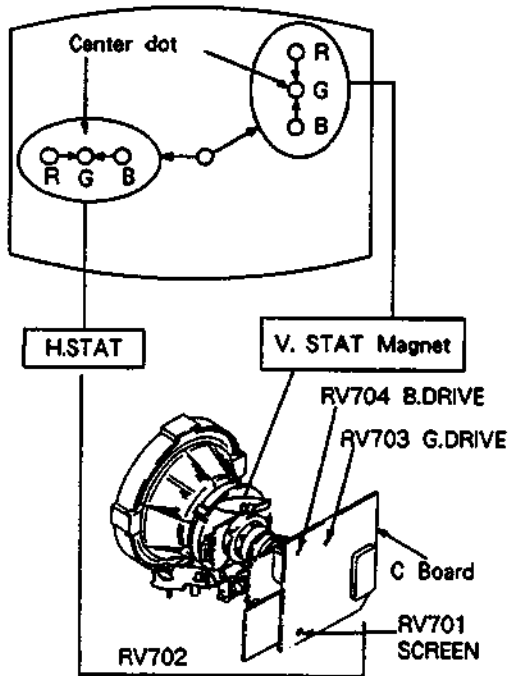

1. (Moving horizontally), adjust the H.STAT control so that the red, green, and blue points are on top of each other at the center of the screen.
2. (Moving vertically), adjust the V.STAT magnet so that the red, green, and blue points are on top of each other at the center of the screen.
3. If the H.STAT variable resistor cannot bring the red, green, and blue points together at the center of the screen, adjust the horizontal convergence with the H.STAT variable resistor and the V. STAT magnet in the manner given below. (In this case, the H.STAT variable resistor and the V. STAT magnet influence each other)

- Tilt the V.STAT magnet and adjust the static convergence by opening or closing the V.STAT magnet.

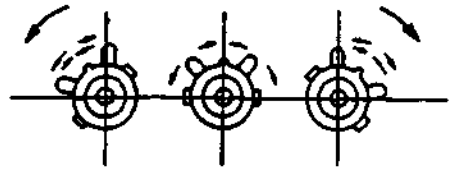

4. If the V.STAT magnet is moved in the direction of the (a) and (b) arrows, the red, green, and blue points move as shown below.

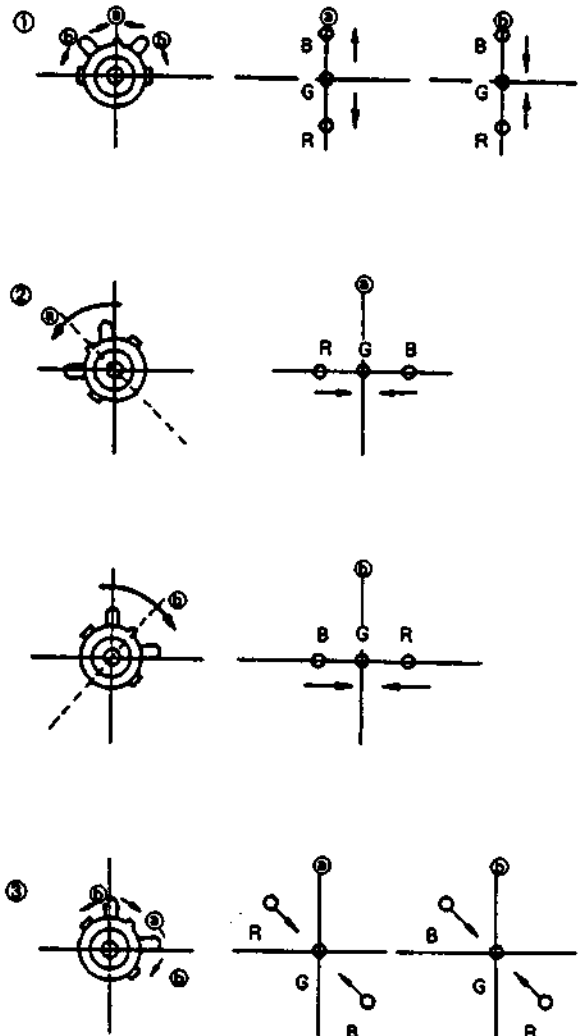

- Operation of BMC (Hexapole) Magnet

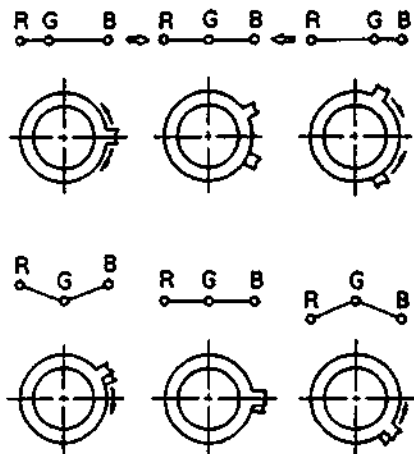

- The respective dot positions resulting from moving each magnet interact, so be sure to perform adjustment while tracking.
Use the H.STAT VR to adjust the red, green, and blue dots so they coincide at the center of screen (by moving the dots in the horizontal direction).

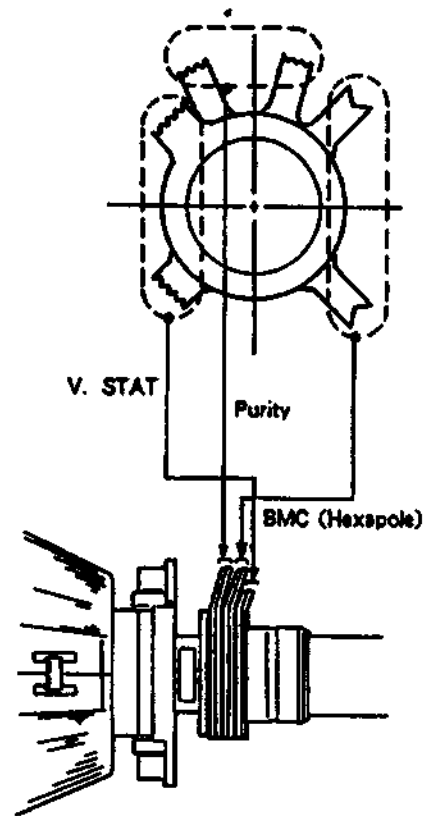

(2)Dynamic convergence adjustment

1. Adjust horizontal convergence located at the center position of the screen with H STAT VR.
2. Enter into service mode. (Refer to the section 2 “Electrical Adjustment” on how to enter service mode.)
3. Select CXA 1526 on menu.
4. Select each item and adjust them so that each item attains optimal convergence.
5. Press **OK** button to write the data.

CXA 1526

Item No.	Adjustment item	Data Amout
01	DC SHIFT	32
02	UPPER Y BOW	4
03	LOWER Y BOW	5
04	H AMP	48
05	H TILT	29
06	UPPER COR BOW	32
07	UPPER TILT	
08	LOWER COR BOW	32
09	LOWER TILT	32

R.G.B.dots movement on the screen of the set

The diagrams illustrate the movement of R.G.B. dots on the screen for each adjustment item. Each diagram shows a rectangular screen with three vertical lines representing the R, G, and B channels. The dots are positioned at the top and bottom of these lines. The adjustments are as follows:

- DC SHIFT:** Fine adjustment of H STAT. Shows three dots moving horizontally towards the center.
- UPPER Y BOW:** Adjustment of Y BOW of the upper section of the screen. Shows the top dots moving inward.
- LOWER Y BOW:** Adjustment of Y BOW of the lower section of the screen. Shows the bottom dots moving inward. An arrow labeled "important" points to the bottom dots.
- H AMP:** H AMP adjustment. Shows the dots moving vertically towards the center.
- H TILT:** H TILT adjustment. Shows the dots moving vertically towards the center.
- UPPER COR BOW:** Adjustment of C BOW of the upper section of the screen. Shows the top dots moving inward.
- UPPER TILT:** Adjustment of TILT of the upper section of the screen. Shows the top dots moving inward.
- LOWER COR BOW:** Adjustment of C BOW of the lower section of the screen. Shows the bottom dots moving inward.
- LOWER TILT:** Adjustment of TILT of the lower section of the screen. Shows the bottom dots moving inward.

At this time, H.TILT, H.AMP, UPPER TILT, UPPER COR, BOW, LOWER TILT, and LOWER COR, BOW look like all the same, but the movement of the right and left dots are reverse in all the TILT system. (Pay attention to the dotted lines.)

(4) Screen corner convergence

If you cannot adjust corner convergence properly, correct them with permalloy.

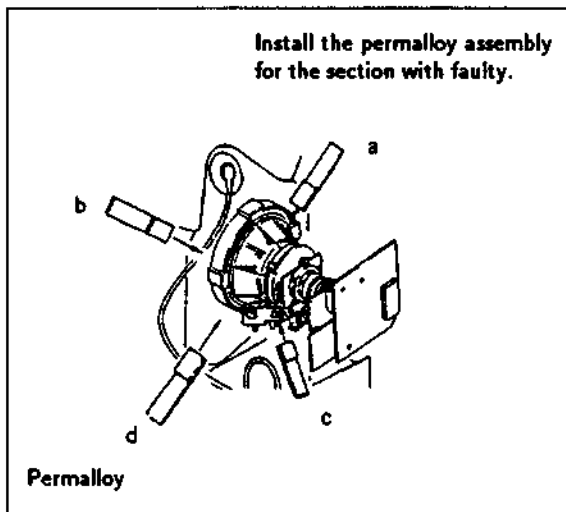
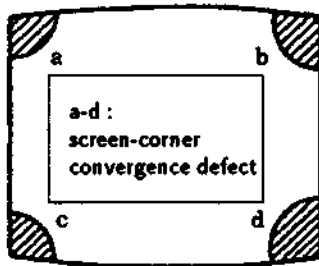
**3-3. FOCUS**

Adjust the focus to optimize the screen.

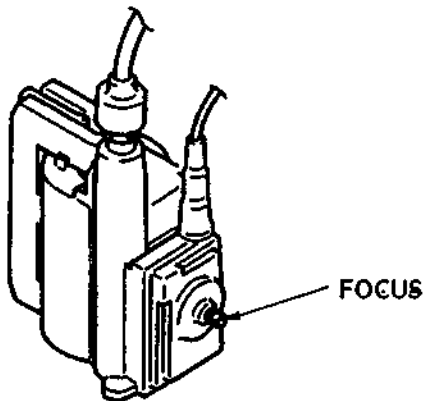
**3-4. WHITE BALANCE****Screen G2 Setting**

1. Input the dot signal from the pattern generator.
2. Set the picture brightness control to its lowest level.
3. Apply 180V DC to the R,G, and B cathodes with an external power supply.
4. While watching the picture, adjust G 2 control RV 701 (Screen) to the point just before the return lines disappear.

White balance adjustment

1. Receive all-white signal.
2. Enter into service mode. (Refer to the section 4 "Electrical Adjustment" to how to enter service mode.)
3. Select CXA 1587S on menu.

CXA 1587S

Item No.	Adjustment item	Data amount
09	SUB BRIGHT	ADJ.
10	SUB HUE	7
11	VM LEVEL	2
12	NR LEVEL	0
13	ABL MODE	0
14	G-DRIVE	ADJ.
15	B-DRIVE	ADJ.
16	G-AUTO CUT OFF	ADJ.
17	B-AUTO CUT OFF	ADJ.
18	R-MANUAL CUT OFF	ADJ.
19	G-MANUAL CUT OFF	ADJ.
20	B-MANUAL CUT OFF	ADJ.

4. Set picture to MAX.
5. Adjust G-DRIVE B-DRIVE with , buttons so that the white balance becomes optimum.
6. Press button to write the data for each item.
7. Set picture to MIN.
8. Adjust G-AUTO CUT OFF, B-AUTO CUT OFF, R-MANUAL CUT OFF, G-MANUAL CUT OFF and B-MANUAL CUT OFF with , buttons so that the white balance becomes optimum.
9. Press button to write the data for each item.

SECTION 4 CIRCUIT ADJUSTMENTS

4-1. ELECTRICAL ADJUSTMENTS

Service adjustment to this model can be performed with the supplied remote commander, RM-832.

HOW TO ENTER INTO SERVICE MODE

1. Turn on the main power switch of the set while pressing any two buttons on the front panel.

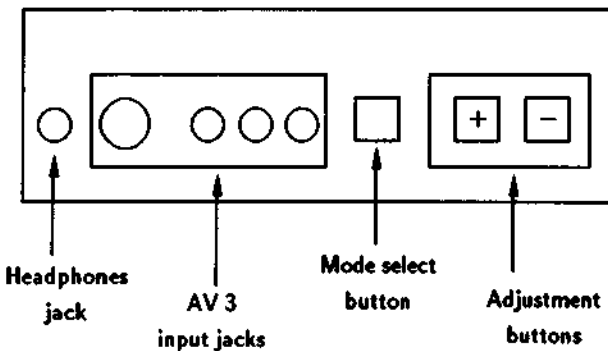

Fig.4-1

2. "TT" will appear on the upper right corner of the screen.

Command operation in service mode

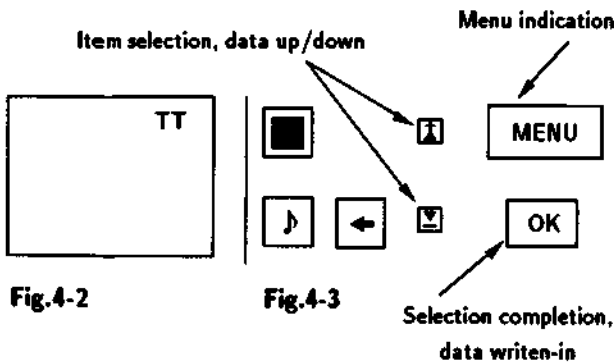

Fig.4-2

Fig.4-3

3. Press the **MENU** button of the commander to get the menu on screen.

MAIN MENU	
Programme Table	
Video Connection	
Timer	
Preset	
Picture Control	
Sound Control	
Language	
> DEMO	
Select [Left] [Right] and press OK	

Fig.4-4

4. Press the **[Left]** and **[Right]** buttons of the commander and move > to DEMO.
5. Press **OK** button to proceed to the next menu.
6. The menu of fig.4-5 will appear on screen. Select **DEVICE** corresponding to the adjustment item from the table on next page.

DEVICES	
Initialize	
> CXA1587S	
CXD 2018	
TDA 9145	
CXA 1526	
TDA 6612	
CX 7948 A	
P/P SERVICE	
Select [Left] [Right] and press OK	

Fig.4-5

7. If adjustment item is CXA1587S, press the **[Right]** button and move > to CXA1587S.

CXA 1587 S

Item No.	Adjustment item	Data Amout
01	PICTURE	53
02	COLOR	31
03	BRIGHT	31
04	HUE	31
05	SHARPNESS	7
06	RGB PICTURE	13
07	SUB CONTRAST	ADJ.
08	SUB COLOR	ADJ.
09	SUB BRIGHT	ADJ.
10	SUB HUE	7
11	VM LEVEL	2
12	NR LEVEL	0
13	ABL MODE	0
14	G-DRIVE	ADJ.
15	B-DRIVE	ADJ.

8. Press **OK** button to get the next selection menu.
9. Press **[Right]** button and move > to the adjustment item and press **OK** button.
10. Press the **[Left]** and **[Right]** buttons to change the data in order to comply each standard.
11. Press **OK** button to write data.
12. Turn off the power to quit service mode when completing the adjustment.

CXA 1587 S

Item No.	Adjustment item	Data Amount
01	PICTURE	53
02	COLOR	31
03	BRIGHT	31
04	HUE	31
05	SHARPNESS	7
06	RGB PICTURE	13
07	SUB CONTRAST	ADJ.
08	SUB COLOR	ADJ.
09	SUB BRIGHT	ADJ.
10	SUB HUE	7
11	VM LEVEL	2
12	NR LEVEL	0
13	ABL MODE	0
14	G-DRIVE	ADJ.
15	B-DRIVE	ADJ.
16	G-AUTO CUT OFF	ADJ.
17	B-AUTO CUT OFF	ADJ.
18	R-MANUAL CUT OFF	ADJ.
19	G-MANUAL CUT OFF	ADJ.
20	B-MANUAL CUT OFF	ADJ.
21	GAMMA LEVEL	0
22	DC TRANSFER RATIO	3
23	DINAMIC PICTURE	0
24	Y FILTER ADJ	ADJ.
25	Y DELAY TIME	15
26	Y DELAY SWITCH 1	0
27	Y DELAY SWITCH 2	1
28	SHARPNESS LIMIT	ON
29	ALL BLK	OFF
30	H SHIFT	32
31	DAC TEST	ON
32	PRE/OVER SHOOT	7
33	SHARPNESS FO	2
34	SUB SHARPNESS	3
35	R MUTE	OFF
36	G MUTE	OFF
37	B MUTE	OFF

CXA 1526

Item No.	Adjustment item	Data Amount
01	DC SHIFT	32
02	UPPER Y BOW	4
03	LOWER Y BOW	5
04	H.AMP	48
05	H TILT	29
06	UPPER COR BOW	32
07	UPPER TILT	32
08	LOWER COR BOW	32
09	LOWER TILT	32

38	AGING 1	OFF
39	AGING 2	OFF
40	AKB OFF	ON
41	INHIBIT RGB	OFF
42	FORCED RGB	OFF
43	V/2 V	OFF
44	AXIS	PAL
45	HUE SW	OFF
46	V EXTENTION	OFF
47	AFC 1	1
48	AFC 2	0
49	AFC OFF	ON
50	REF.POSITION	0

CXD 2018

Item No.	Adjustment item	Data Amount
01	V SIZE	ADJ.
02	V SHIFT	ADJ.
03	S CORRECTION	ADJ.
04	V LINEARITY	ADJ.
05	H SIZE	ADJ.
06	PIN AMP	ADJ.
07	TILT	ADJ.
08	UPPER CORNER	ADJ.
09	LOWER CORNER	ADJ.
10	V BOW	ADJ.
11	ANGLE	ADJ.
12	HV COMP.V	13
13	HV COMP.H	8
14	FRAME SHIFT	OFF
15	FREE RUN 60 Hz	OFF
16	SYSTEM 60 Hz	OFF
17	ASPECT WIDE	OFF
18	DOUBLE SCAN	OFF
19	INTERLACE	ON
20	H SHIFT	32
21	N/S CORRECTION	ADJ.

Typical Value (OSD based)when receiving PAL Philips pattern.

TDA 6612

Adjustment item	Data Amount
Stereo-Separation	30

Should be adjusted twice 4 : 3 and 16 : 9 mode.

Y FILTER ADJUSTMENT

1. Input PAL RED pattern.
2. Connect an oscilloscope to CN 0403 ① pin (R OUT) on the C board.
3. Enter into service mode and press 3, 8.
4. Adjust data by Δ or ∇ to minimize the chroma element of CN 0403 ① pin.

SUB BRIGHTNESS ADJUSTMENT

1. Input Phillips pattern.
2. Enter into service mode and press 23.
3. Adjust data so that 0-IRE of the grey scale and CUT -OFF 20-IRE glitter slightly.

SUB CONTRAST ADJUSTMENT

1. Input a video that contains small 100% area on the Black Back ground.
2. Enter into service mode and press 01 to have PIC max followed by 21.
3. Adjust data so that 2.5 Vp-p can be obtained at ① CN 0403 (R out).

SUB COLOR ADJUSTMENT

1. Input PAL color bar.
2. Connect an oscilloscope to CN 0403 ③ pin (B OUT) on the C board.
3. Enter into service mode and press 22 of CXA1587S, 8 SUB COLOR.
4. Adjust data so that the right sides of the waveform will be the same.

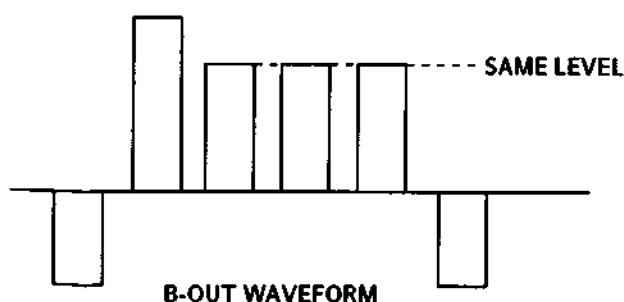
**STEREO-SEPARATION ADJUSTMENT**

1. Input 1 kHz stereo signal to the L-ch and 400 Hz stereo signal to the R-ch.
2. Enter into service mode and press 19.
3. Adjust data so that sound does not leak to the R-ch and the L-ch.

DRIVE AND CUT OFF

See direct test mode list attached and refer to sub brightness or such for adjustment method.

DEFLECTION SYSTEM ADJUSTMENT

1. Enter into service mode and select CXD 2018.
2. Select and adjust each item in order to get an optimum image.

CXD 2018

Item No.	Adjustment item	Data Amount
01	V SIZE	ADJ.
02	V SHIFT	ADJ.
03	S CORRECTION	ADJ.
04	V LINEARITY	ADJ.
05	H SIZE	ADJ.
06	PIN AMP	ADJ.
07	TILT	ADJ.
08	UPPER CORNER	ADJ.
09	LOWER CORNER	ADJ.
10	V BOW	ADJ.
11	ANGLE	ADJ.
12	HV COMP.V	13
13	HV COMP.H	8
14	FRAME SHIFT	OFF
15	FREE RUN 60 Hz	OFF
16	SYSTEM 60 Hz	OFF
17	ASPECT WIDE	OFF
18	DOUBLE SCAM	OFF
19	NON INTERLACE	ON
20	H SHIFT	32
21	N/S CORRECTION	ADJ.

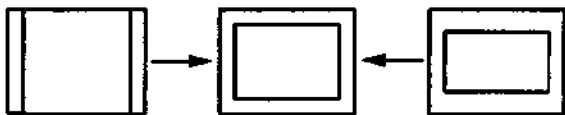
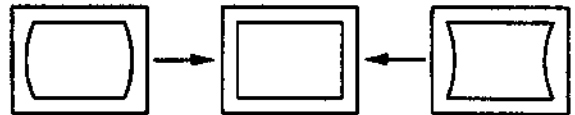
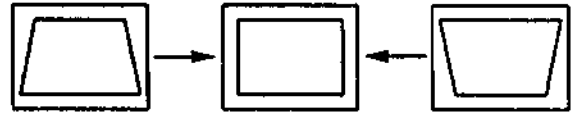
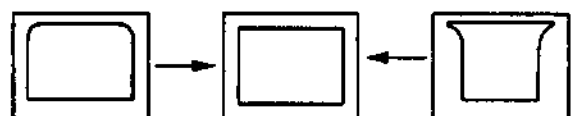
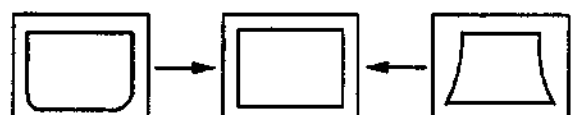
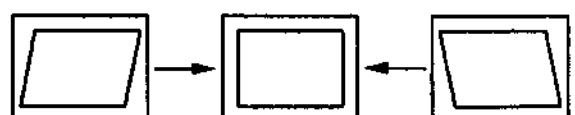
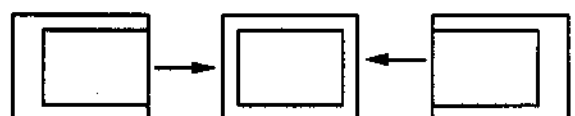
V SIZE**V SHIFT****S CORRECTION****V LINEARITY****H SIZE****PIN AMP****TILT****UPPER CORNER PIN****LOWER CORNER PIN****V BOW****ANGLE****H SHIFT****N/S CORRECTION**

3. Press **OK** button to write the data.

If menu display may disturb the adjustment press **✕** to clear, to resume it, press **✕** again.

4-2. VOLUME ELECTRICAL ADJUSTMENTS

+B (+135 V) ADJUSTMENT (RV 601)

D BOARD

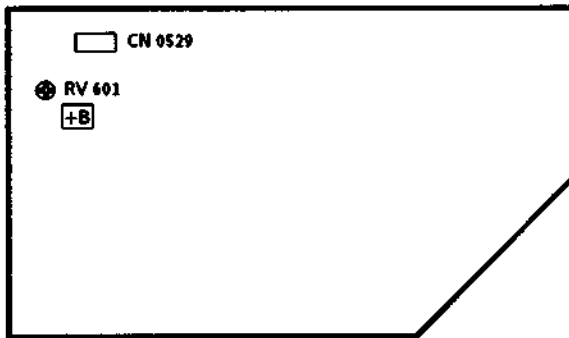

1. Turn on the power of the TV set.
2. Connect a digital multi-meter to ① pin of CN 0529 on D board.
3. Adjust RV 601 on D board to $+135 \pm 0.5$ V.

H.FREQ ADJUSTMENT (RV 506)

M BOARD

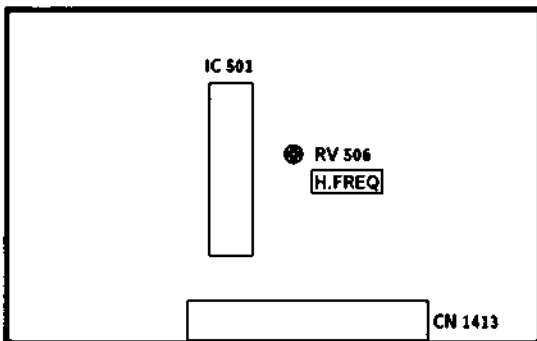

1. Connect GND to ⑫ pin of IC 501 on M board.
2. Connect a frequency counter to ④ pin of IC 501.
3. Adjust RV 506 on M board to $15,625 \text{ kHz} \pm 10 \text{ Hz}$.
4. Remove ⑫ pin of IC 501 from GND.

PLS WDTN

D 2 BOARD

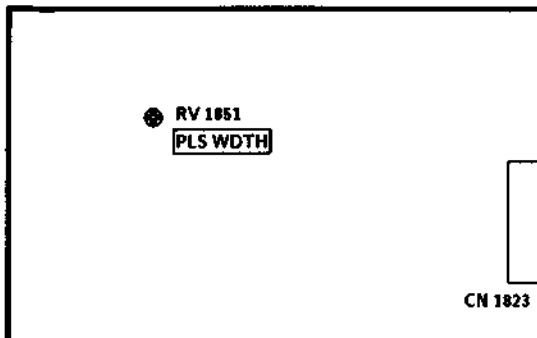

DRIVE PULSE PHASE ADJUSTMENT (RV 1851)

- 1) While measuring the voltage V 1 at both edges of C 1859, rotate RV 1851 so that it becomes minimum. The adjusting range is from (the voltage at which V 1 becomes minimum) V 1 MIN to 3 V, which means, adjust to between V 1 MIN to V 1 MIN + 3 V.

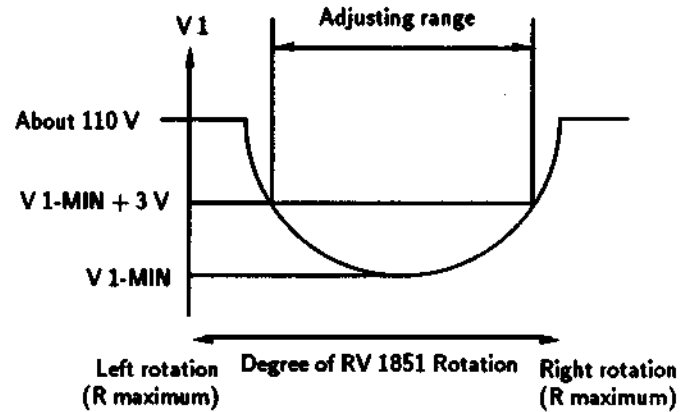

TEXT CLOCK ADJUSTMENT (CT 01)

V BOARD

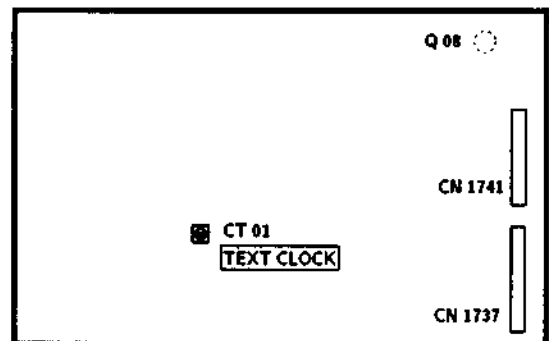

1. Get TEXT MENU on screen.
2. Connect GND and the base of Q 08 on V board.
3. Adjust CT 01 on V board so that the MENU stands still as much as possible.

AGC ADJUSTMENT (IF BLOCK)

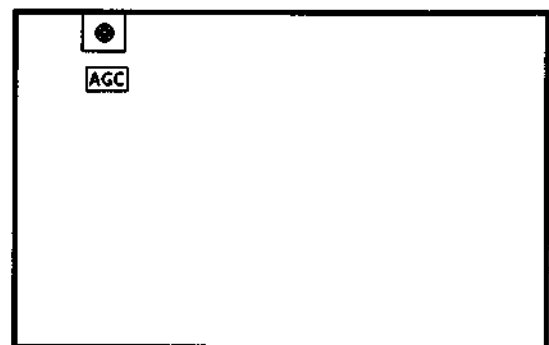

1. Receive off-air signal.
2. Adjust AGC VR so that there is no snow noise and cross-modulation.
3. Change receiving channel and confirm status.

4-3. TEST MODE 2 :

Is available by pressing Test button two times, OSD "TT" appears. The functions described bellow are available by pressing the two numbers. To release the Test Mode 2, press two times 0, or switch TV in Standby Mode.

00	switch Test Mode 2 off
01	picture maximum
02	picture minimum
03	Volume 35%
04	Volume 50%
05	Volume 65%
06	Volume 80%
07	Aging Condition (Volumin., Picture max., Brightness max., Aging 2 Mode of CXA 1587S, TDA 2595 is locked to CXA 1587S via PIN 34 of μ -Con.)
08	Shipping Condition (Analog Values are RESET due to factory setting, Prog 1 is selected, TT Mode is switched off)
09	dummy
10	Tenth entry is deleted
11	Balance
12	Hue
13-14	dummy
15	Read factory setting from NVM Reads Volume, Balance, Treble, Bass, Brightness, Contrast, Hue, Sharpness, Colour values from ROM to the actual used values (Last Power Memory)
16	Save actual used values as RESET values Memorize actual used values Balance, Treble, Bass, Hue, Sharpness at RESET position in NVM
17	Preset Level for AV Sources
18	dummy
19	Stereo Separation
20	Tenth entry is deleted
21	Sub Contrast
22	Sub Colour
23	Sub Brightness
24-29	dummy

30	Tenth entry is deleted
31	Green Drive
32	Blue Drive
33	Green Cut Off (Auto Cut Off)
34	Blue Cut Off (Auto Cut Off)
35	Red Cut Off (Manual Cut Off) (Auto Cut Off is switched off)
36	Green Cut Off (Manual Cut Off) (Auto Cut Off is switched off)
37	Blue Cut Off (Manual Cut Off) (Auto Cut Off is switched off)
38	Y-Filter adjustment (Trap is switched off and TDA 9145 is switched in forced NTSC Mode)
39	dummy
40	Tenth entry is deleted
41	Default setting of CXA 1587, ^S (Only in Plog 99 available)
42	Default setting of CXA 2018 (Only in Plog 99 available)
43	Default setting of CXA 1526 (Only in Plog 99 available)
44	(all Port High) Not yet
45	(all Port High) Not yet
46-48	dummy
49	Erase the NVM Testbyte (this byte detects already stored NMV's) After selecting this function, switch TV Off and On → the NVM will be preset by μ -Controller. (Not the channel data)

Note : For No. 35, 36, 37 and 38 special pressing (AKB, forced Color Mode, Trap) is selected. After selecting a new Test Mode Number, the AKB is switched ON, the Trap is switched On and TDA 9145 is switched to Auto Search Mode.

In Test Mode 2 the Menu display is switchable by Speaker-Off button.

4-4. ERROR MESSAGE

Self diagnos system can operates as follows.

- When MP can't get the acknowledge back from the device, LED starts flashing according to the table as attached.

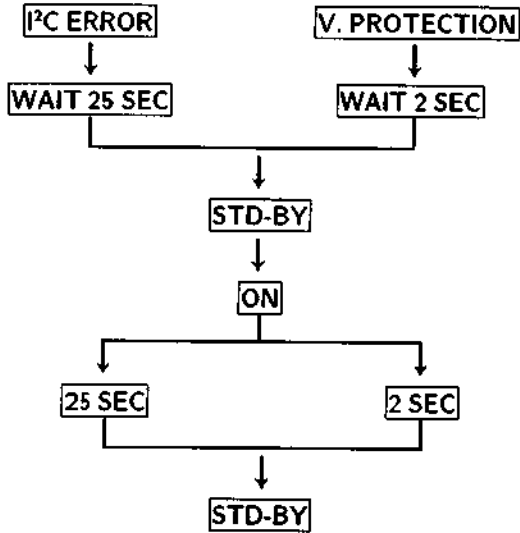

In case of more errors in parallel, the blinking error shows max. Priority according to the error number (e.g. error 2 and error 5 appears together, then LEDs shows error 2) .

TABLE OF ERRORS

ERROR COUNT	IC TYPE	FUNCTION
1	I ² C BUS	SDA low
2	X 24 C 16	EEPROM
3	SDA 3202	Tuner PII
4	TDA 9145	Colour decoder
5	CXA 15875	RGB/Jungle
6	TDA 6612	Sound processor
7	CXD 2018	V deflection
8	CXA 1545	AV switch
11	SDA 5248	Text
13		V protection

Stand by LED blinking

No IK return

4-5. ERROR I²C BUS DIAGNOSIS SYSTEM IN AE 2 CHASSIS

For all ICs in AE 2 chassis which are necessary to get picture and sound there is a built in error I²C Bus diagnosis system.

In case of no acknowledge bit, LED A and LED B starts blinking as shown.

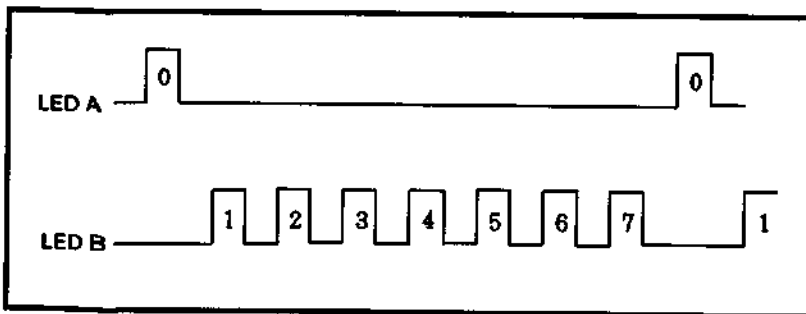

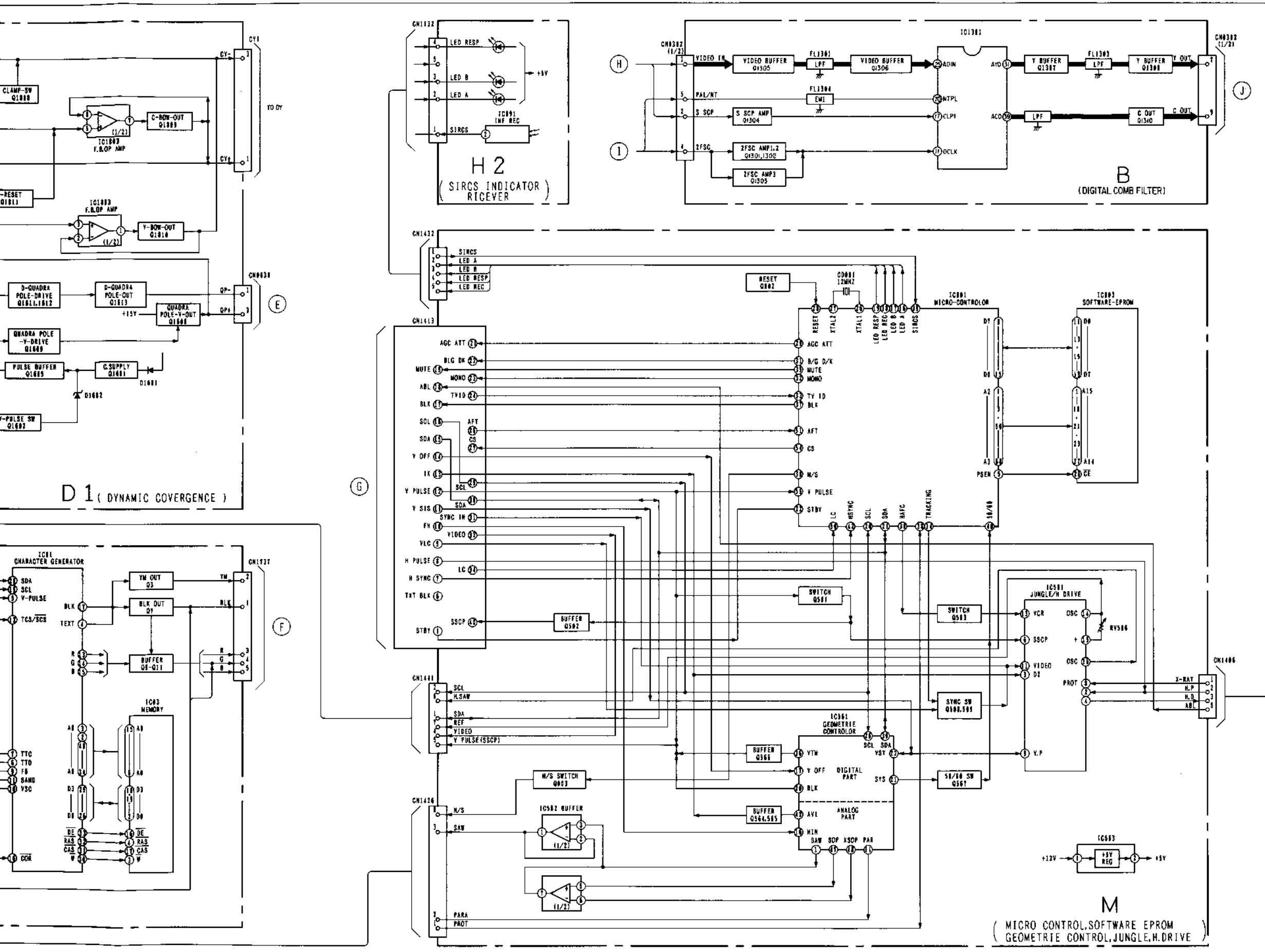

5-2. BLOCK DIAGRAM (2)

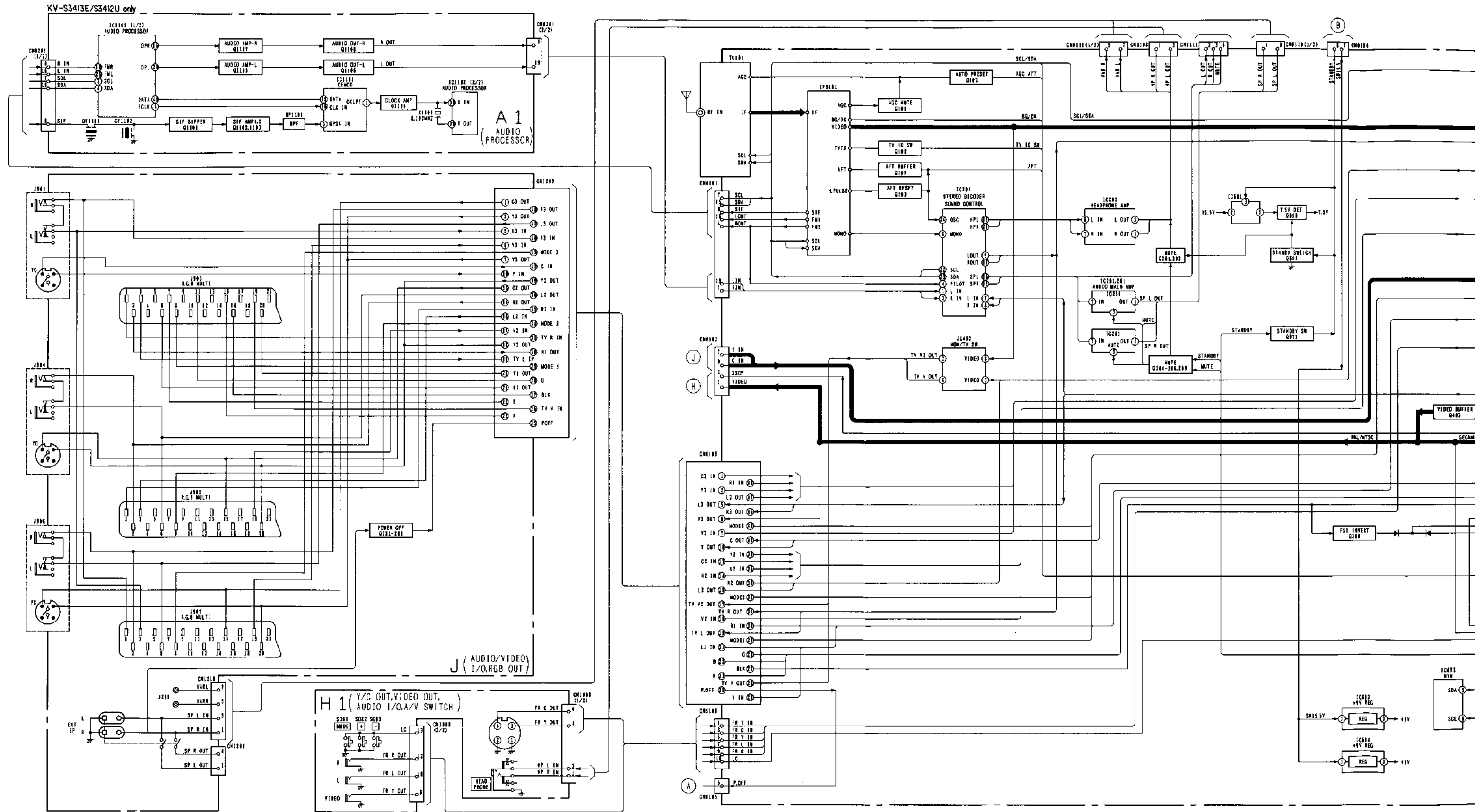

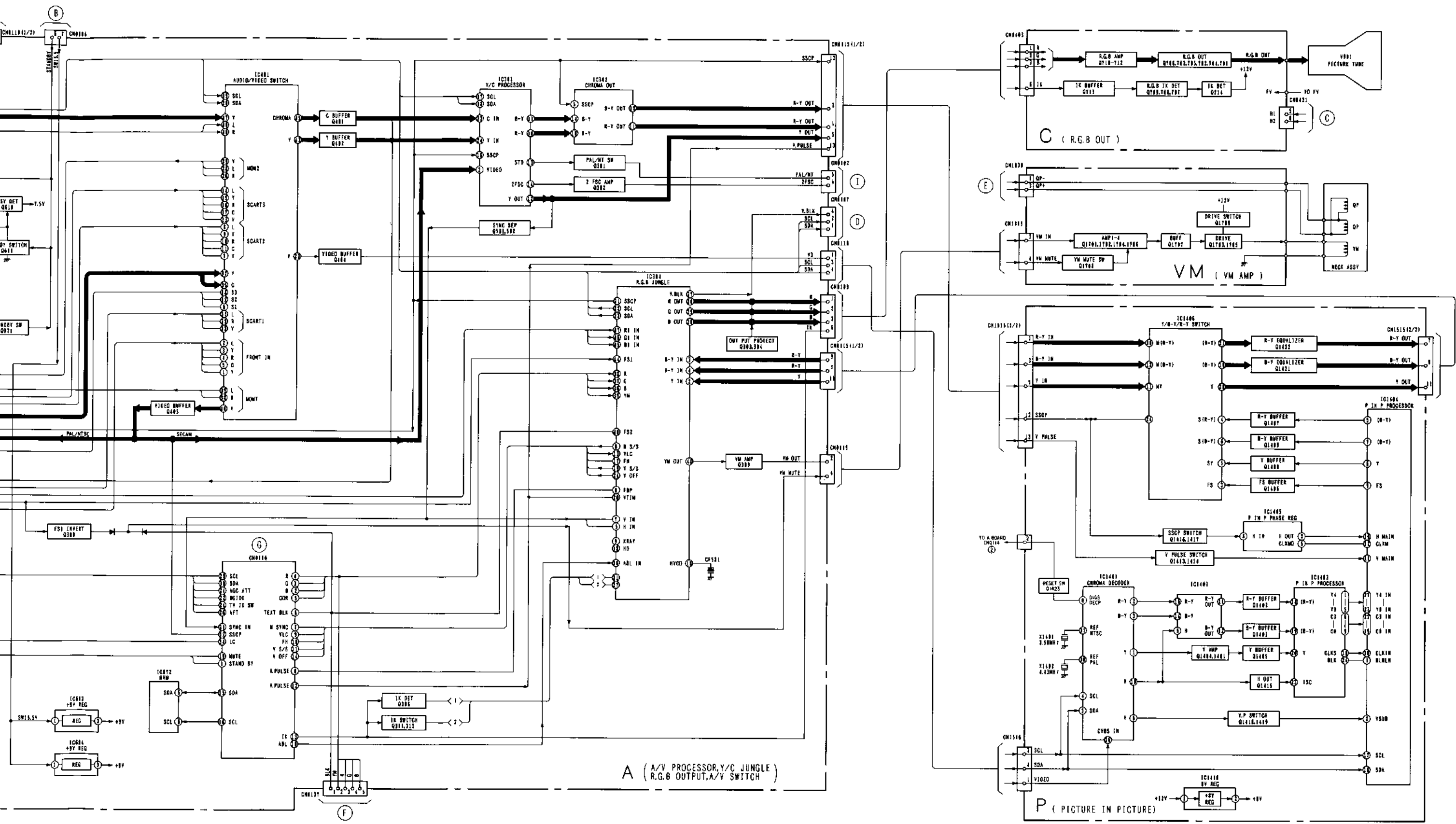

5-3. CIRCUIT BOARDS LOCATION

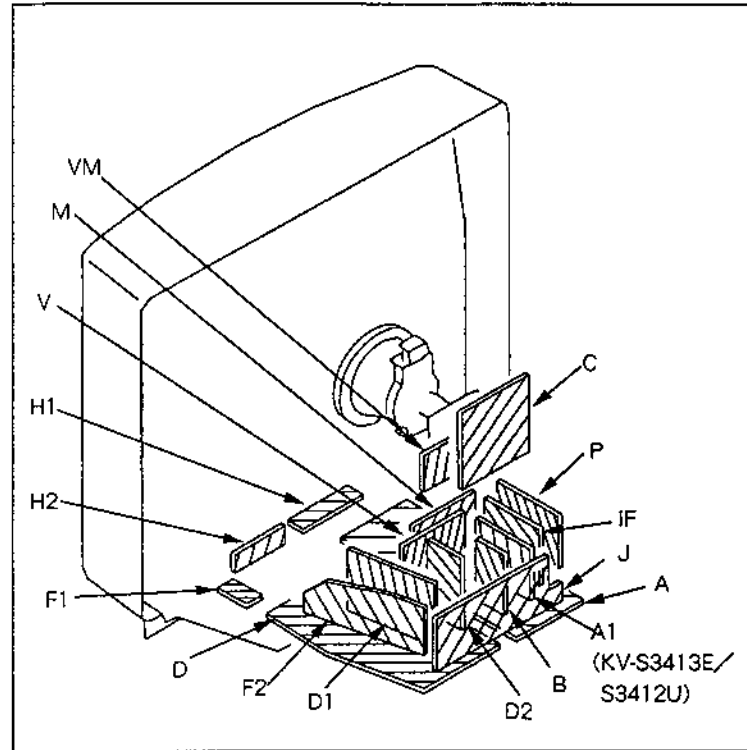

Reference information

RESISTOR	RN	: METAL FILM
	RC	: SOLID
	FPRD	: NONFLAMMABLE CARBON
	FUSE	: NONFLAMMABLE FUSIBLE
	RS	: NONFLAMMABLE METAL OXIDE
	RB	: NONFLAMMABLE CEMENT
	RW	: NONFLAMMABLE WIREWOUND
	*	: ADJUSTMENT RESISTOR
COIL	LF-8L	: MICRO INDUCTOR
CAPACITOR	TA	: TANTALUM
	PS	: STYROL
	PP	: POLYPROPYLENE
	PT	: MYLAR
	MPS	: METALIZED POLYESTER
	MPP	: METALIZED POLYPROPYLENE
	ALB	: BIPOLAR
	ALT	: HIGH TEMPERATURE
	ALR	: HIGH RIPPLE

Note: The components identified by shading and mark are critical for safety. Replace only with part number specified.

Note: Les composants identifiés par une trame et par une marque sont d'une importance critique pour la sécurité. Ne les remplacer que par des pièces de numéro spécifié.

5-4. SCHEMATIC DIAGRAMS AND PRINTED WIRING BOARDS

Note :

- All capacitors are in μF unless otherwise noted. pF : $\mu \mu F$ 50WV or less are not indicated except for electrolytic.
- Indication of resistance, which dose not have one for rating electrical power, is as follows.

Pitch : 5mm
Rating electrical power : 1/4W

- Chip resistor is in 1/10W.
- All resistors are in ohms. $k\Omega = 1000\Omega$, $M\Omega = 1000K\Omega$
- : nonflammable resistor.
- : fusible resistor.
- Δ : internal component.
- : panel designation or adjustment for repair.
- All variable and adjustable resistors have characteristic curve B, unless otherwise noted.
- \perp : earth - ground
- \perp (with diagonal line) : earth - chassis
- All voltages are in V.
- Readings are taken with a 10M Ω digital multimeter.
- Readings are taken with a color-bar signal input.
- Voltage variations may be noted due to normal production tolerances.
- : B+ bus.
- : B- bus.
- : signal path.(RF)

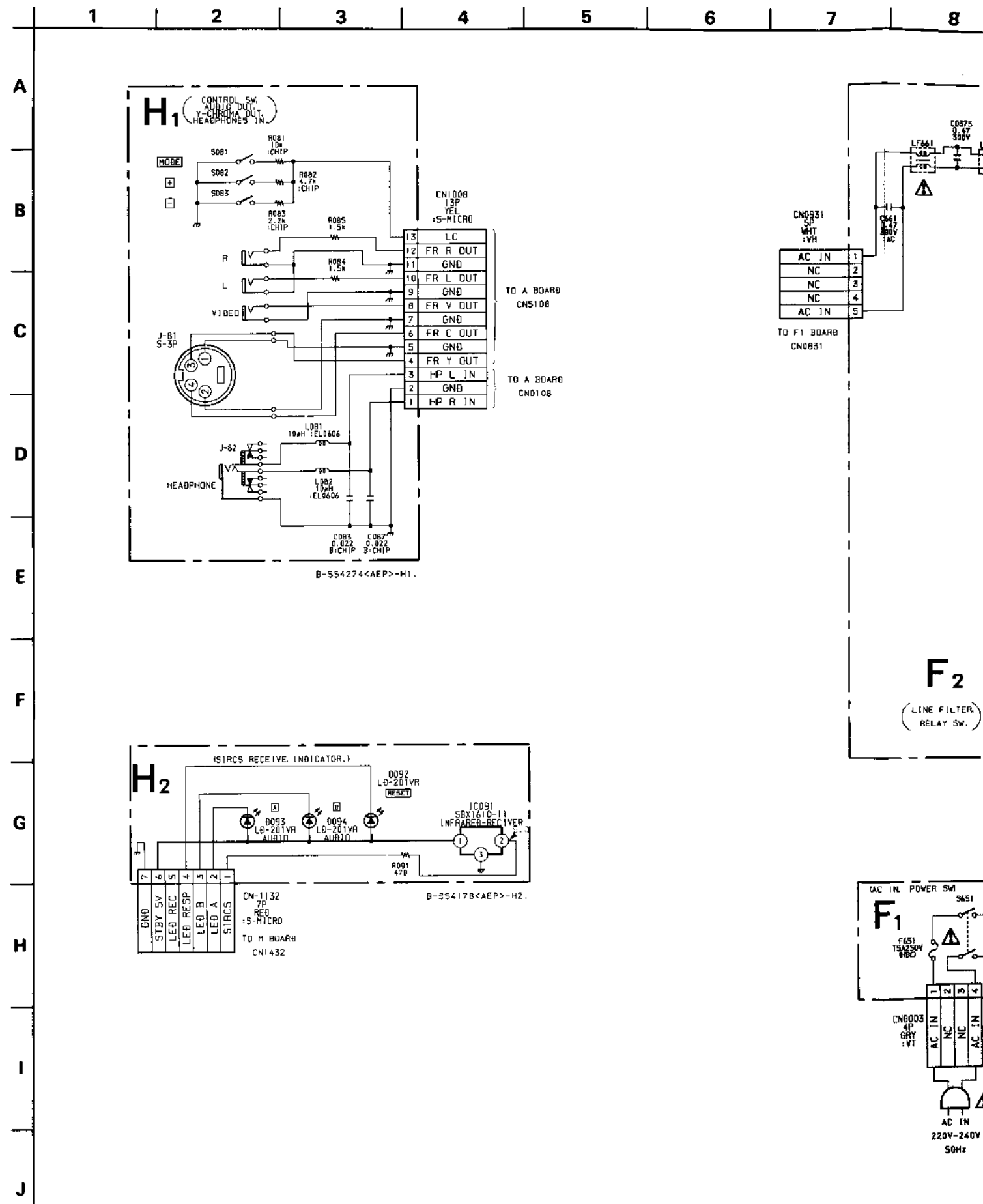

1 2 3 4 5 6 7 8 9 10 11 12 13 14

A B C D E F G H I J

J AUDIO IN/OUT
Y-CHROMA IN/OUT
VIDEO IN/OUT

- J BOARD -

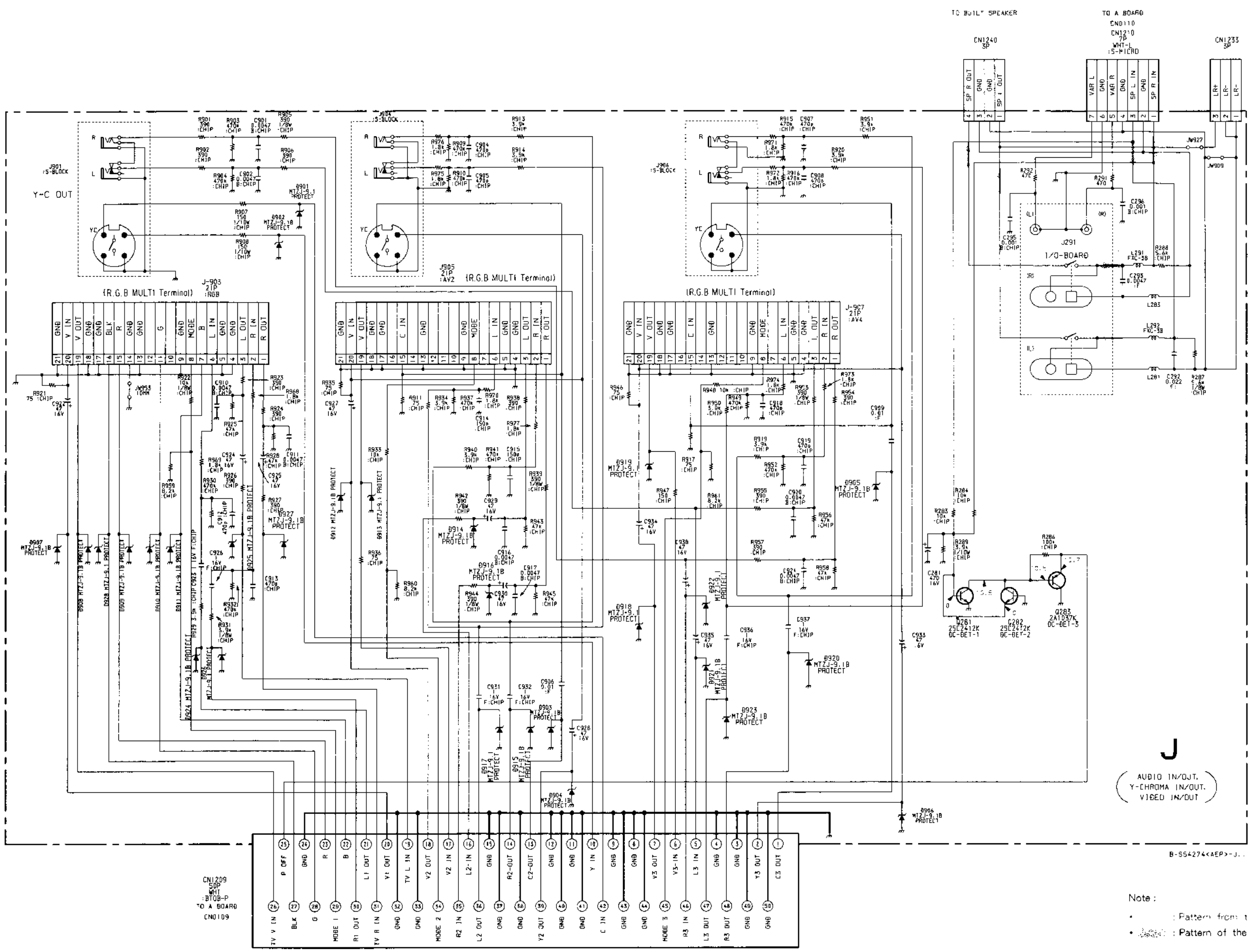

J
AUDIO IN/OUT,
Y-CHROMA IN/OUT,
VIDEO IN/OUT

Note:
• : Pattern from the side which enables seeing.
• : Pattern of the rear side.



12 13 14

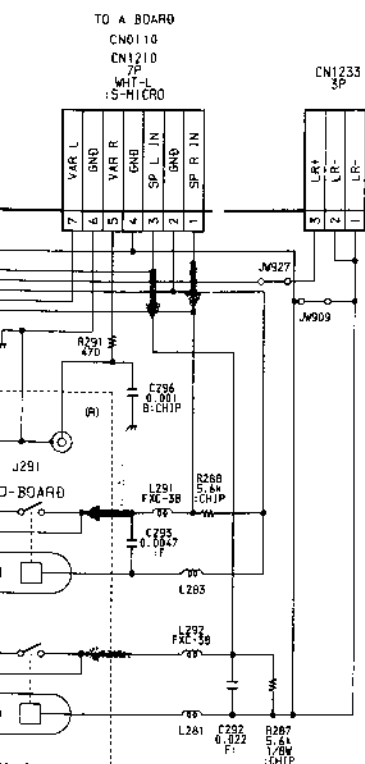

J [AUDIO IN/OUT, Y-CHROMA IN/OUT, VIDEO IN/OUT]

A [TUNER, AUDIO, CONTROL, AUDIO AMP, AV SWITCH, RGB JUNGLE, Y/C PROCESSOR]

- J BOARD -

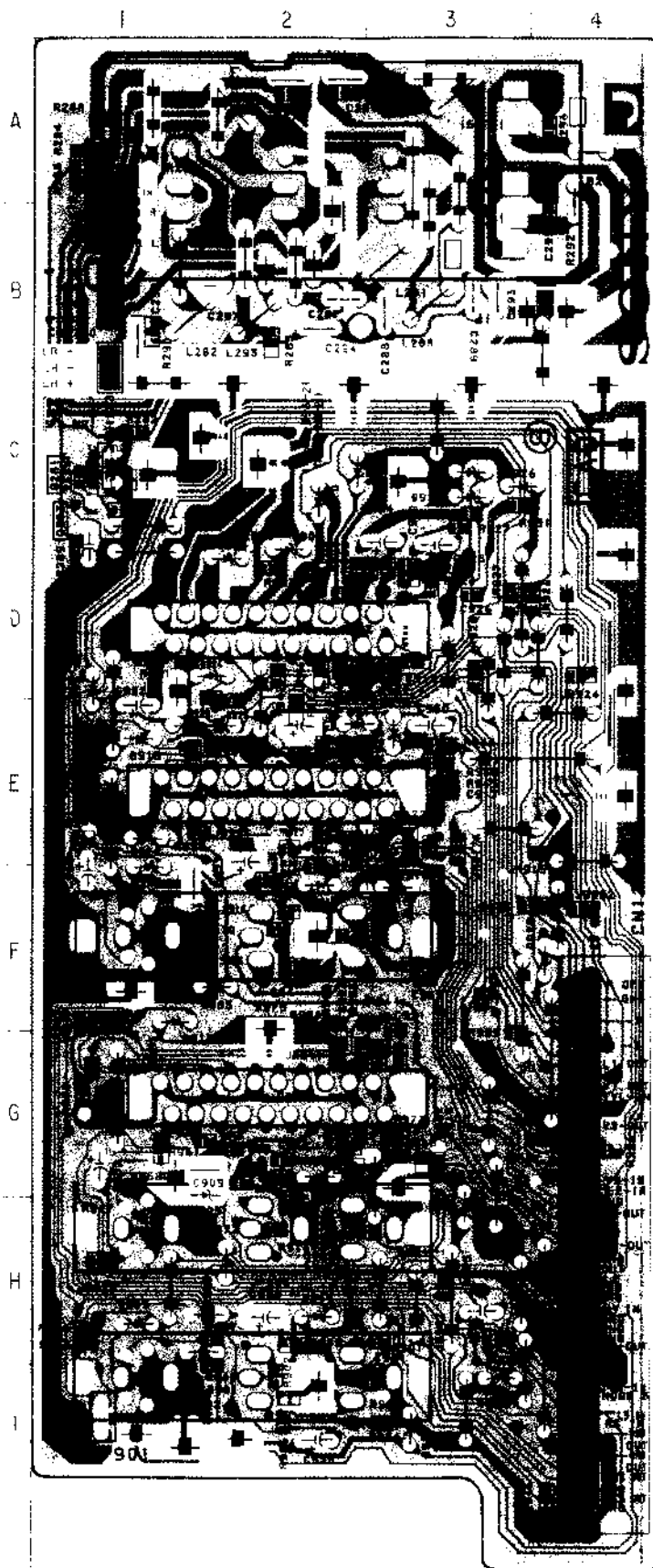

- A BOARD -

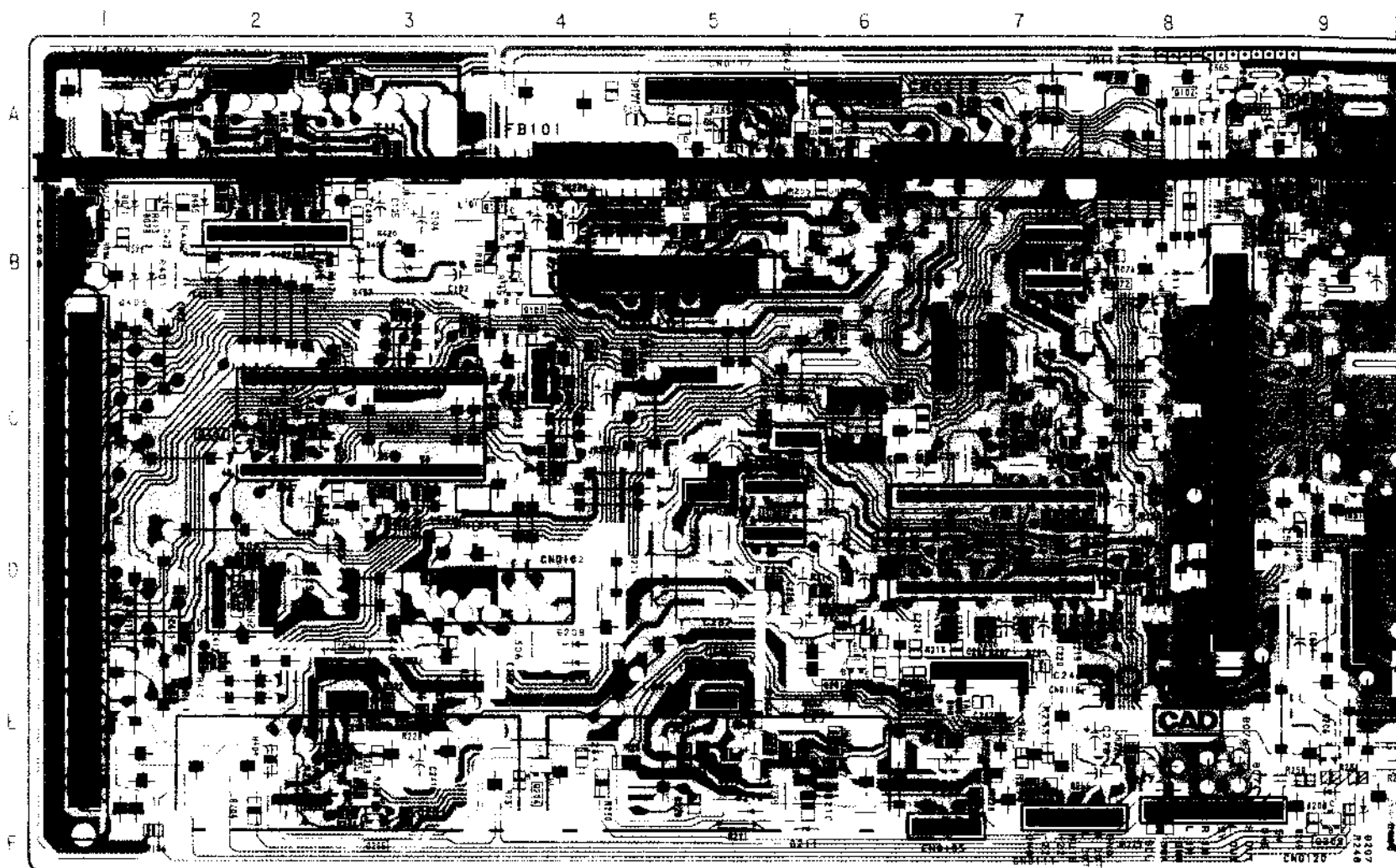

TRANSISTOR			
Q281	C-1	D912	E-1
Q282	C-1	D913	E-1
		D914	F-2
		D915	F-3
		D916	E-3
		D917	F-2
		D918	I-3
		D919	F-1
		D920	H-3
		D921	I-3
		D922	H-2
		D923	G-2
		D924	D-2
		D925	C-3
		D926	C-3
		D927	C-3
		D928	F-4
DIODE			
D901	H-2		
D902	H-1		
D903	F-2		
D904	F-1		
D905	G-2		
D906	H-2		
D907	D-1		
D908	D-2		
D909	D-2		
D910	C-2		
D911	C-2		

J
AUDIO IN/OUT,
Y-CHROMA IN/OUT,
VIDEO IN/OUT

B-554274<<AEP>>-J...

Note:
 • : Pattern from the side which enables seeing.
 • : Pattern of the rear side.

AUDIO, CONTROL, AUDIO AMP
TCH, RGB JUNGLE,
PROCESSOR

- A BOARD -

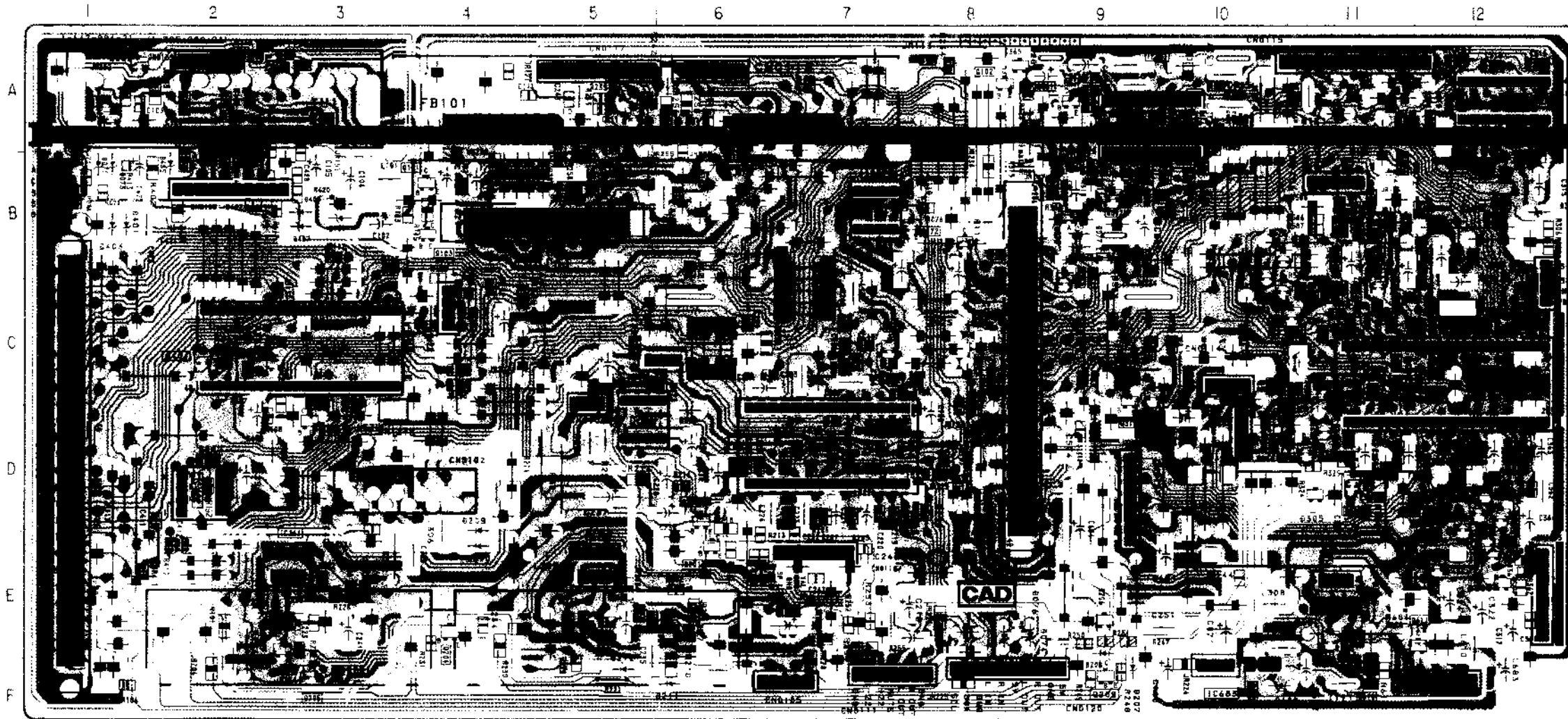

IC		Q404	C-4
IC072	B-7	Q581	C-11
IC201	D-7	Q582	C-10
IC202	D-5	Q610	F-11
IC251	E-5	Q611	E-12
IC261	E-3	Q683	F-10
IC301	A-9	DIODE	
IC302	A-12		
IC304	C-12	D068	B-9
IC401	C-3	D069	A-1
IC402	D-2	D071	B-1
IC681	E-11	D073	B-1
IC683	F-10	D075	A-1
IC684	C-6	D077	B-9
TRANSISTOR		D078	B-9
Q071	E-11	D079	B-9
Q101	B-4	D101	B-3
Q102	A-8	D206	E-9
Q103	B-4	D207	F-9
Q201	E-6	D208	E-9
Q202	D-6	D209	E-4
Q203	A-5	D210	E-4
Q204	E-4	D211	F-6
Q205	F-3	D212	F-5
Q206	E-3	D213	E-7
Q207	B-8	D301	B-10
Q209	F-9	D302	A-11
Q210		D304	B-12
Q301	A-9	D305	D-11
Q302	B-9	D306	D-12
Q303	D-12	D307	E-12
Q304	D-12	D308	E-12
Q305	A-10	D311	D-11
Q306	E-12	D381	C-10
Q308	D-11	D401	B-1
Q309	D-11	D403	B-1
Q311	C-9	D405	B-2
Q312	C-9	D406	B-3
Q313		D407	B-3
Q401	C-2	D571	C-11
Q402	C-2	D682	F-10
Q403	D-3		

Note:

• : Pattern of the rear side.

TRANSISTOR		D912	E-1
Q281	C-1	D913	E-1
Q282	C-1	D914	F-2
DIODE		D915	F-3
D901	H-2	D916	E-3
D902	H-1	D917	F-2
D903	F-2	D918	I-3
D904	F-1	D919	F-1
D905	G-2	D920	H-3
D906	H-2	D921	I-3
D907	D-1	D922	H-2
D908	D-2	D923	G-2
D909	D-2	D924	D-2
D910	C-2	D925	C-3
D911	C-2	D926	C-3
		D927	C-3
		D928	F-4

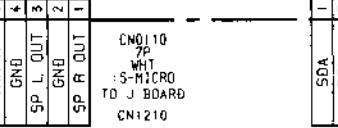
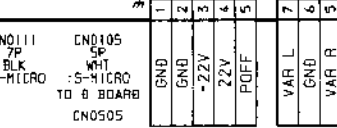
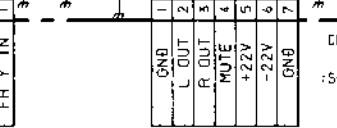
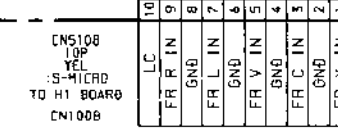
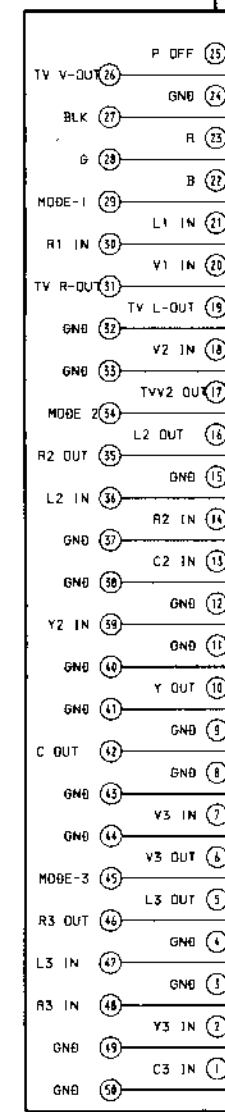
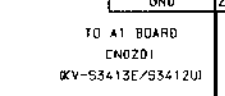
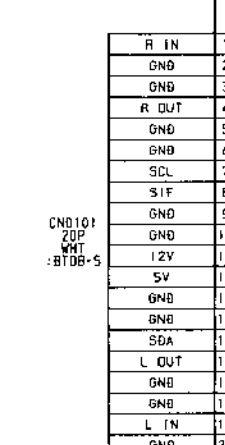
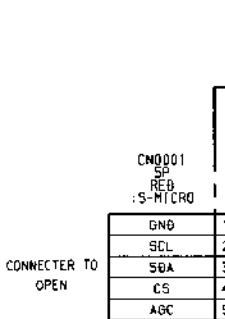
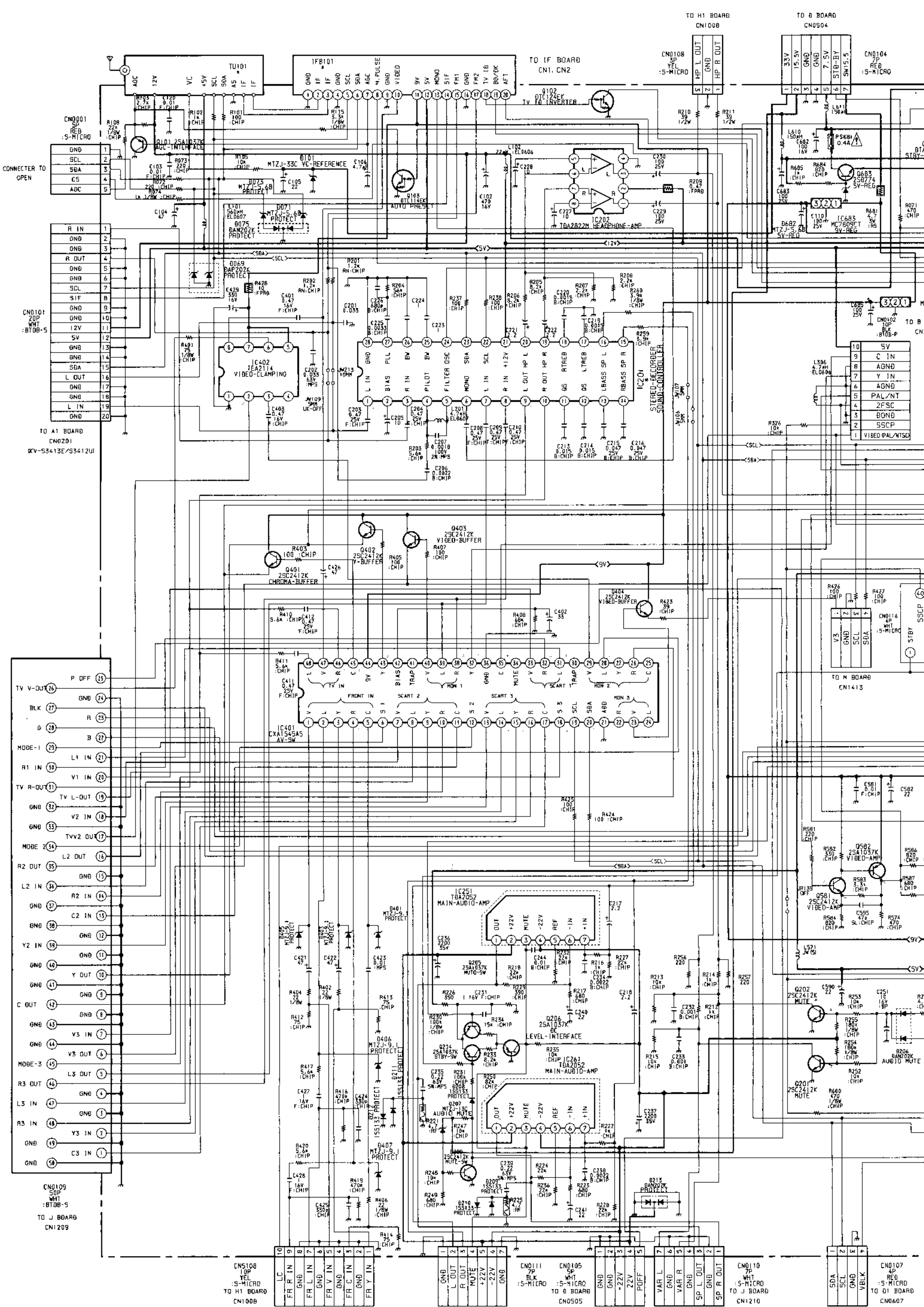

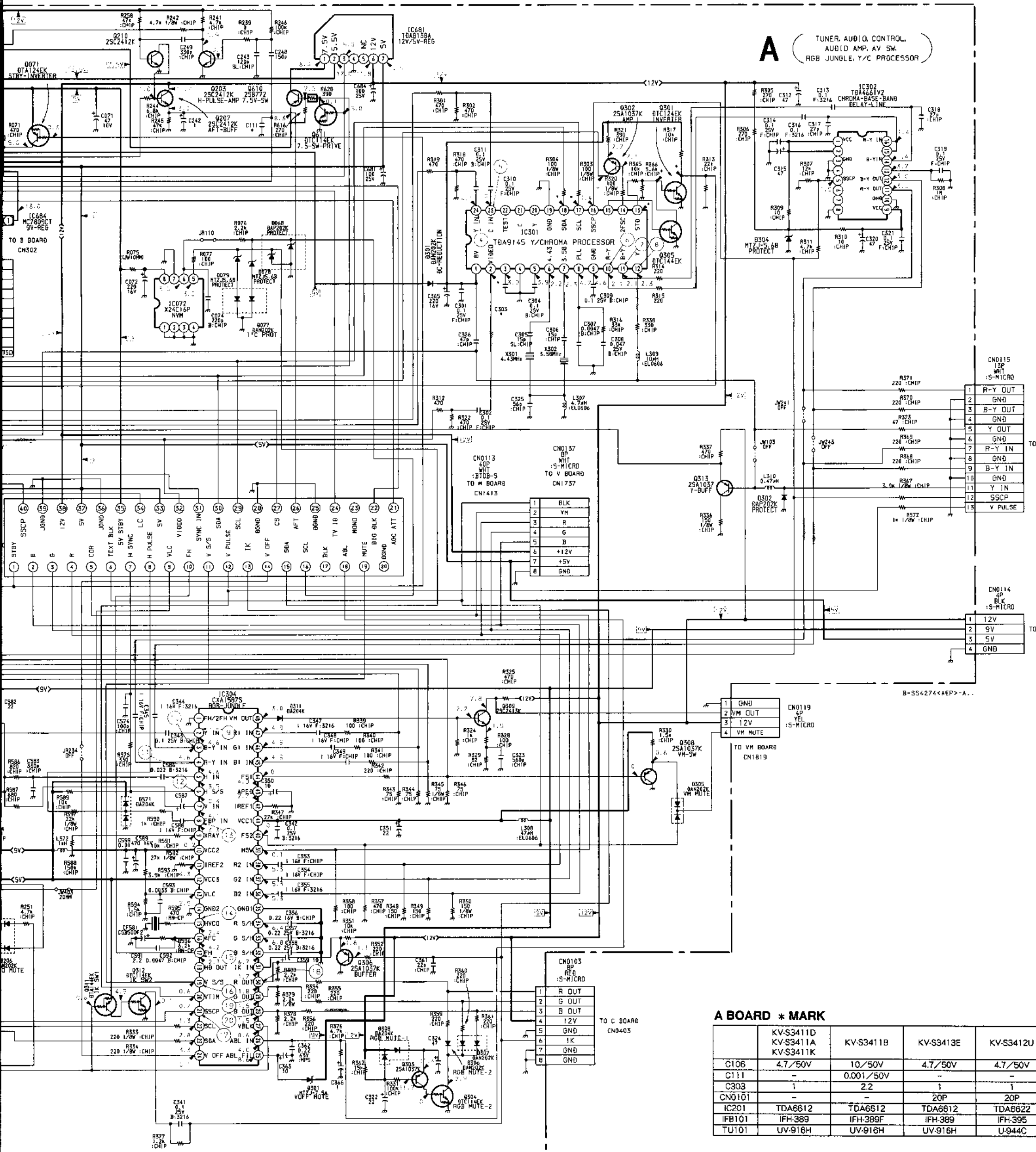

A (TUNER, AUDIO, CONTROL, AUDIO AMP, AV SW, RGB JUNGLE, Y/C PROCESSOR)

A BOARD * MARK

	KV-S3411D KV-S3411A KV-S3411K	KV-S3411B	KV-S3413E	KV-S3412U
C106	4.7/50V	10/50V	4.7/50V	4.7/50V
C111	-	0.001/50V	-	-
C303	-	2.2	1	1
CN0101	-	-	20P	20P
IC201	TDA6612	TDA6612	TDA6612	TDA6622
IFB101	IFH-389	IFH-389F	IFH-389	IFH-395
TU101	UV-916H	UV-916H	UV-916H	U-944C

IC301	PAL	SECAM	NTSC4.43	NTSC3.58
②	4.0	4.0	4.0	4.8
③	0	0	4.9	4.9
④	3.1	2.8	2.5	2.5
⑤	3.1	3.1	2.8	2.8
⑥	0	0	1.6	1.6
(C)	4.4	4.4	0.1	0.1

• A BOARD IC201 TDA6612

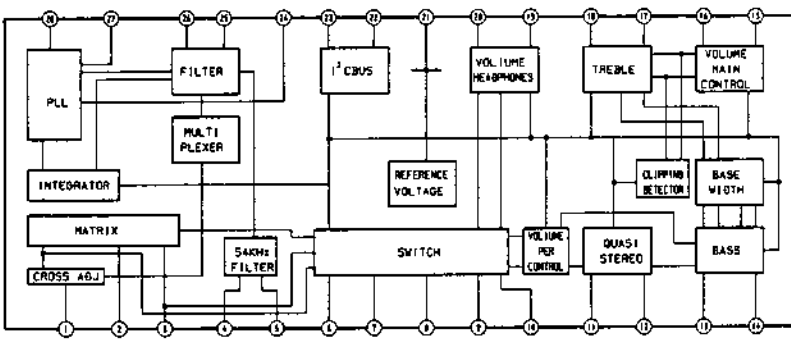

• A BOARD IC201 TDA6622 (UK Model only)

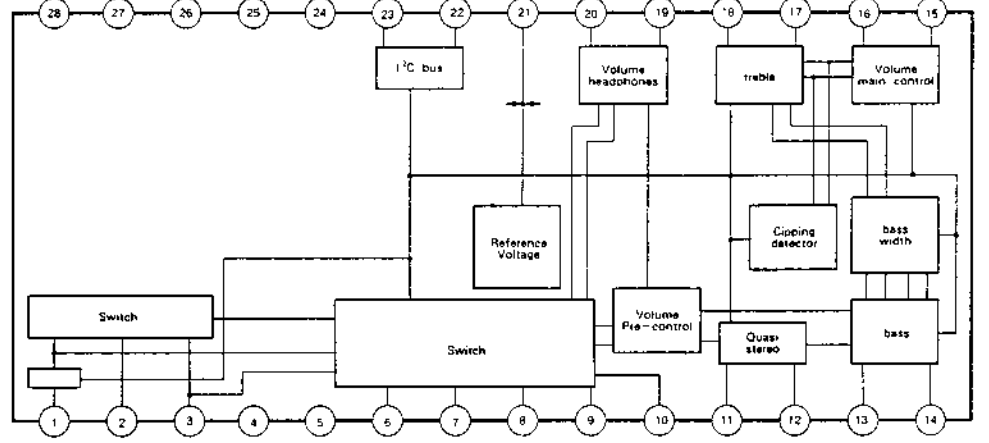

• A BOARD IC251/261 TDA2052

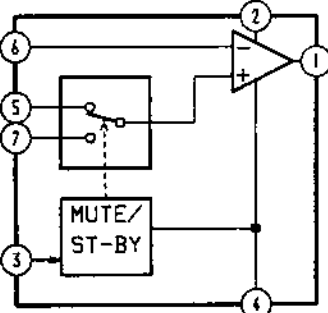

• A BOARD IC301 TDA9145

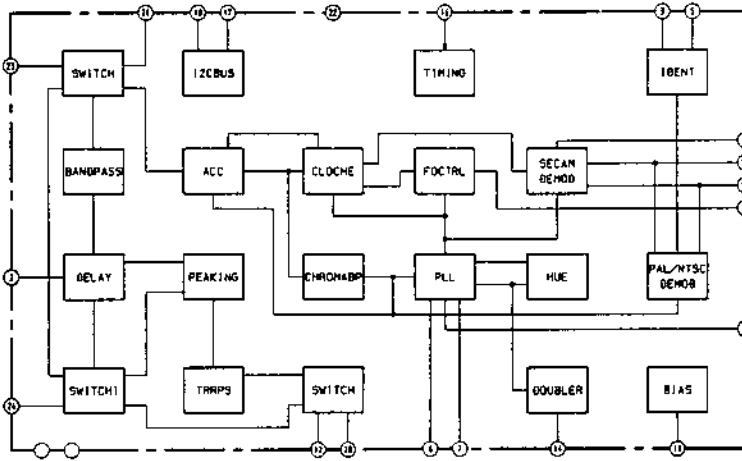

• A BOARD IC402 TEA2114

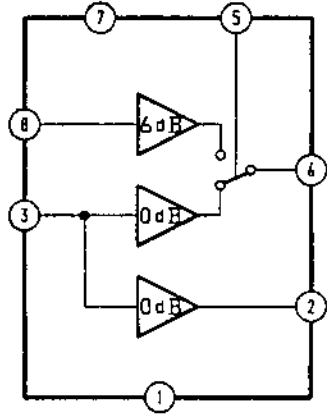

• A BOARD IC304 CXA1587S

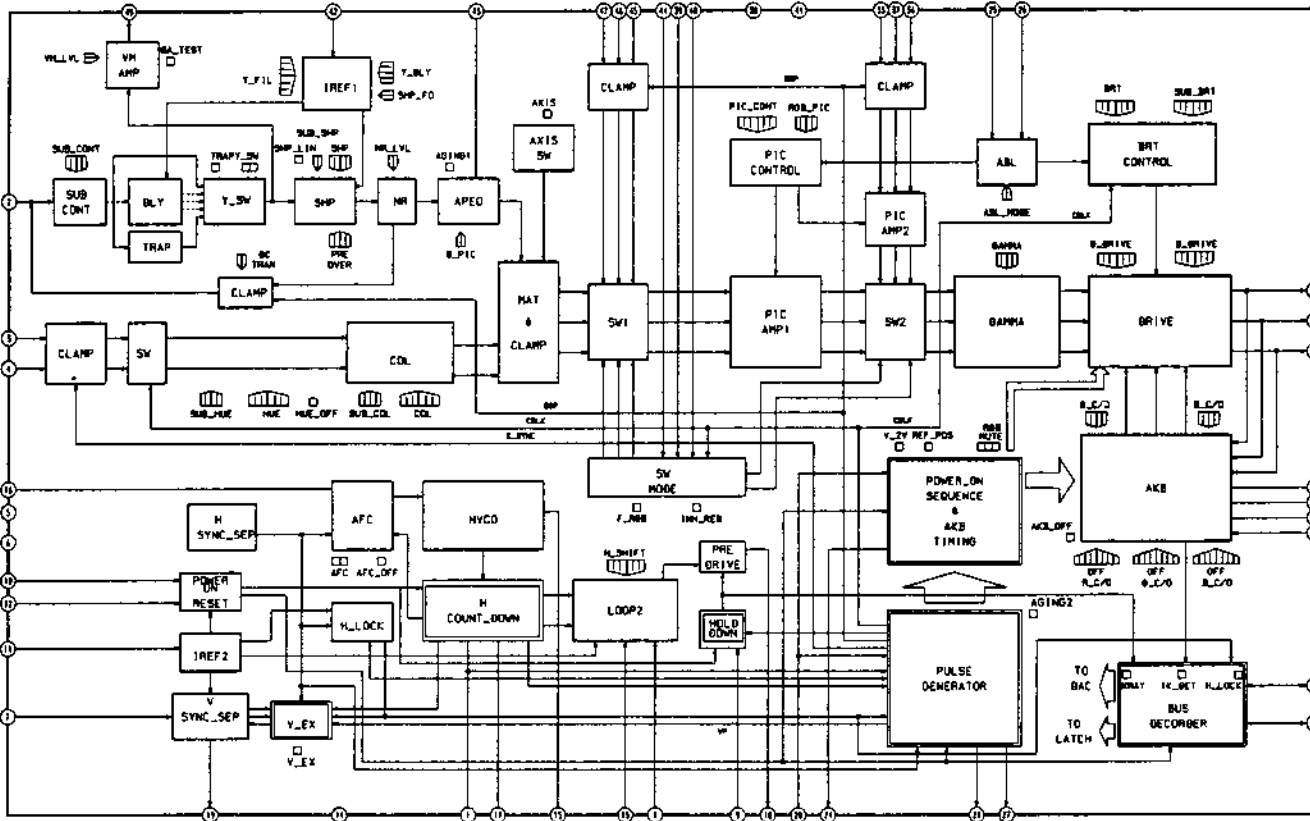

• A BOARD IC681 TDA8138

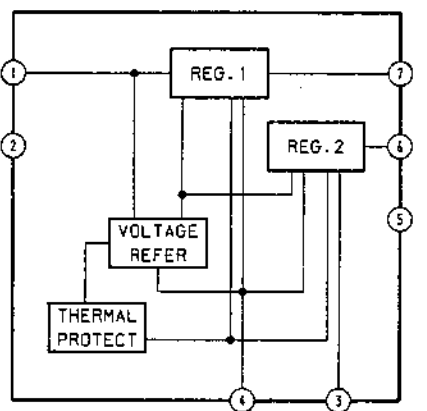

• WAVEFORMS A BOARD

① PAL 1.0Vp-p (H)	① SECAM 1.0Vp-p (H)	① NTSC 1.0Vp-p (H)	② PAL 1.4Vp-p (H)	② SECAM 0.7 Vp-p (H)	② NTSC 0.75Vp-p (H)	③ PAL 1.7 Vp-p (H)
③ SECAM 1.8Vp-p (H)	③ NTSC 1.8Vp-p (H)	④ PAL 1.0Vp-p (H)	④ SECAM 1.1Vp-p (H)	④ NTSC 1.3 Vp-p (H)	⑤ PAL 0.7 Vp-p (H)	⑤ SECAM 0.4Vp-p (H)
⑤ NTSC 0.36Vp-p (H)	⑥ PAL, NTSC 0.7Vp-p (H)	⑥ SECAM 1.1Vp-p (H)	⑦ PAL 1.0 Vp-p (H)	⑦ SECAM 1.6Vp-p (H)	⑦ NTSC 0.85Vp-p (H)	⑧ PAL 0.4Vp-p (H)
⑧ SECAM 0.5Vp-p (H)	⑧ NTSC 0.48Vp-p (H)	⑨ 0.4 Vp-p (H)	⑩ 1.9Vp-p (H)	⑪ 1.4 Vp-p (H)	⑫ 4.8 Vp-p (H)	⑬ 6.4Vp-p (H)
⑭ 0.1Vp-p (500KHZ)	⑮ 4.3 Vp-p (H)	⑯ 4.3 Vp-p (V)	⑰ 8.0Vp-p (H)	⑱ 2.8 Vp-p (H)	⑲ 2.4Vp-p (H)	⑳ 2.3Vp-p (H)

CN015
3P
WHT
S-MICRO
R-Y OUT
GND
B-Y OUT
GND
Y OUT
GND
R-Y IN
GND
B-Y IN
GND
Y IN
SSCP
V PULSE
TO P BOARD
CN1515

CN014
4P
BLK
S-MICRO
12V
9V
5V
GND
TO P BOARD
CN1514

KV-S3412U
4.7/50V
-
1
20P
TDA6622
IFH395
U-944C

1	
A	
B	CN1426 6P VEL :S-MICRO
	PROT
	PARA
	SAW+
	GND
	+5V
	N/S
	TO D BOARD CN0526

1	
E	
F	
G	
H	
I	
J	
K	
L	
M	
N	
O	
	CN1441 8P REF :S-MICRO
	SDA
	SCL
	GND
	VIDEO
	SSCP
	H.SAW
	REF
	GND
	TO V BOARD CN1741

• M BOARD IC561 CXD2018Q

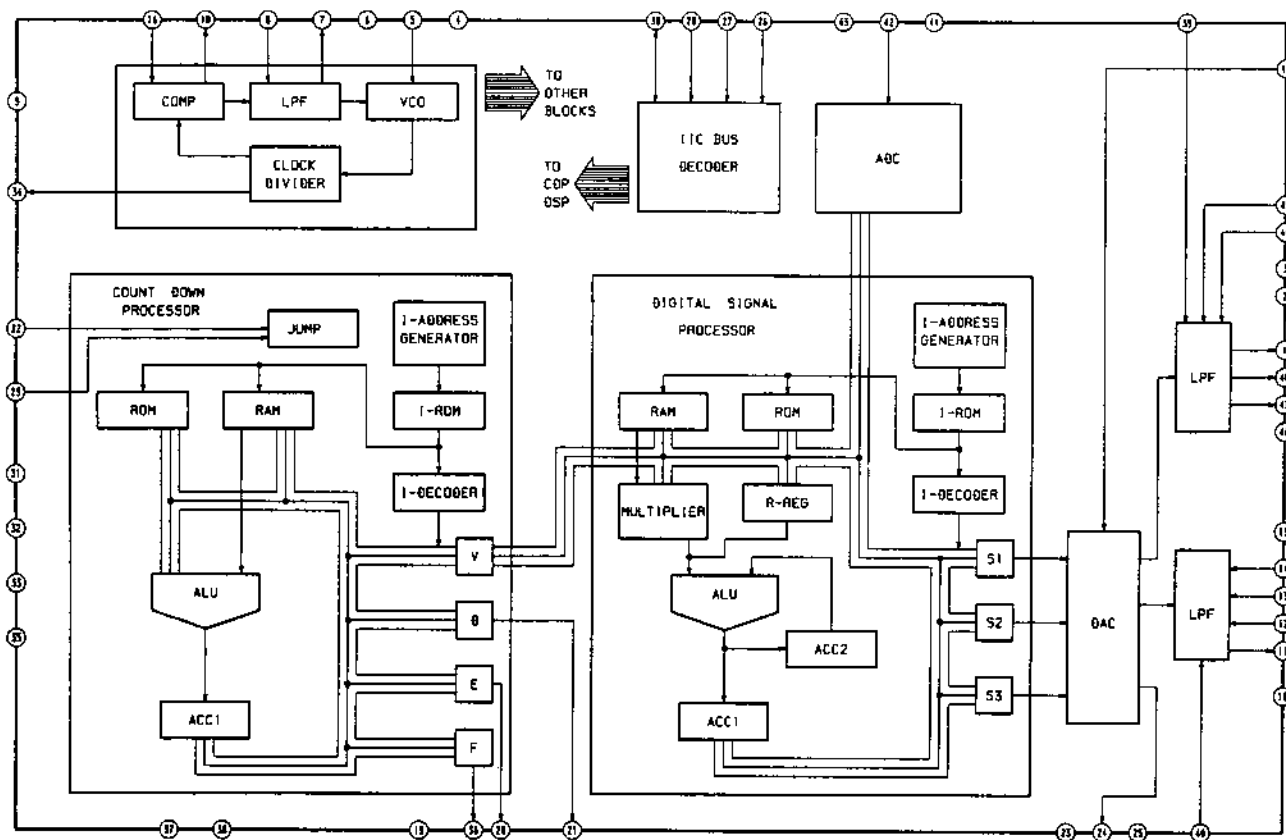

• M BOARD IC501 TDA2595-V9

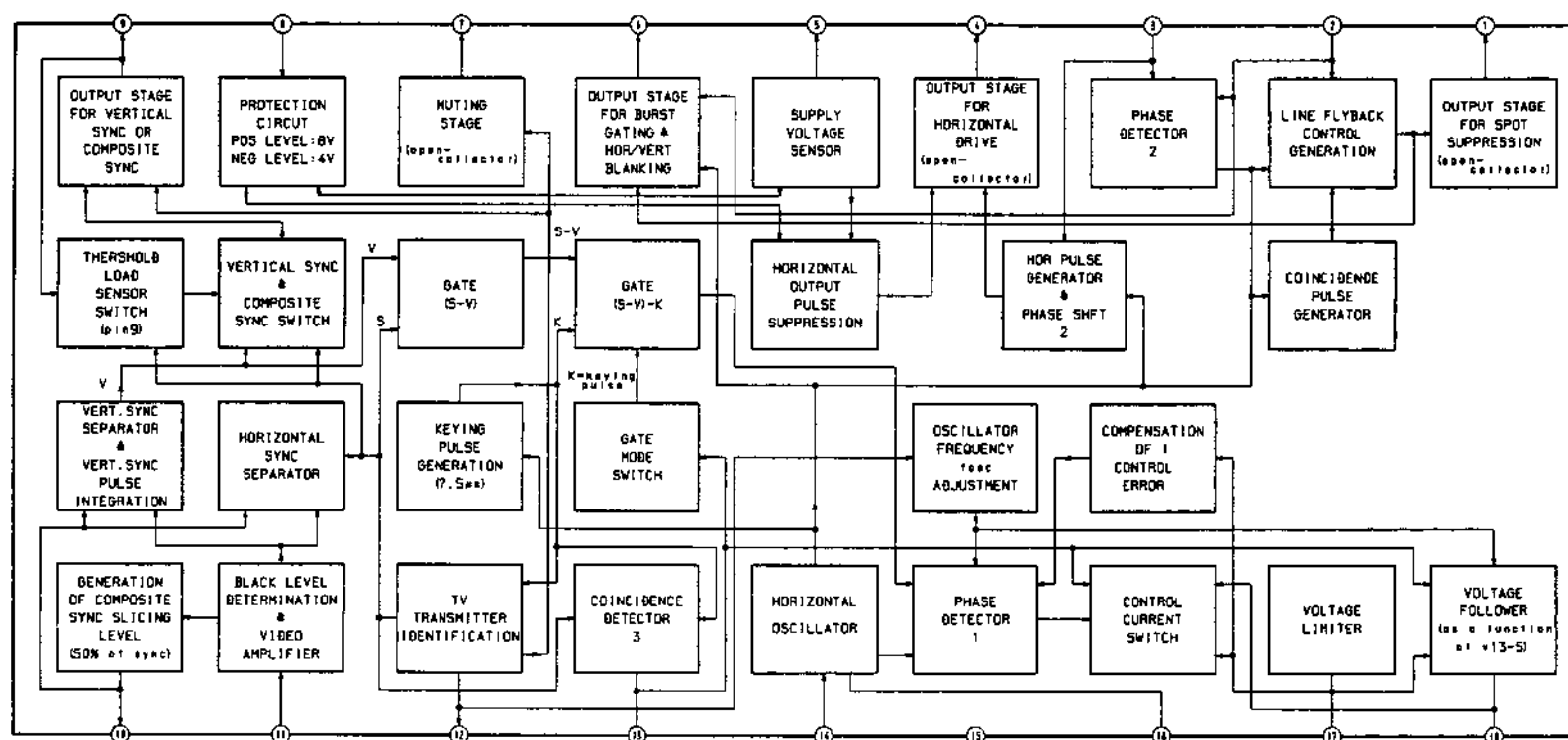

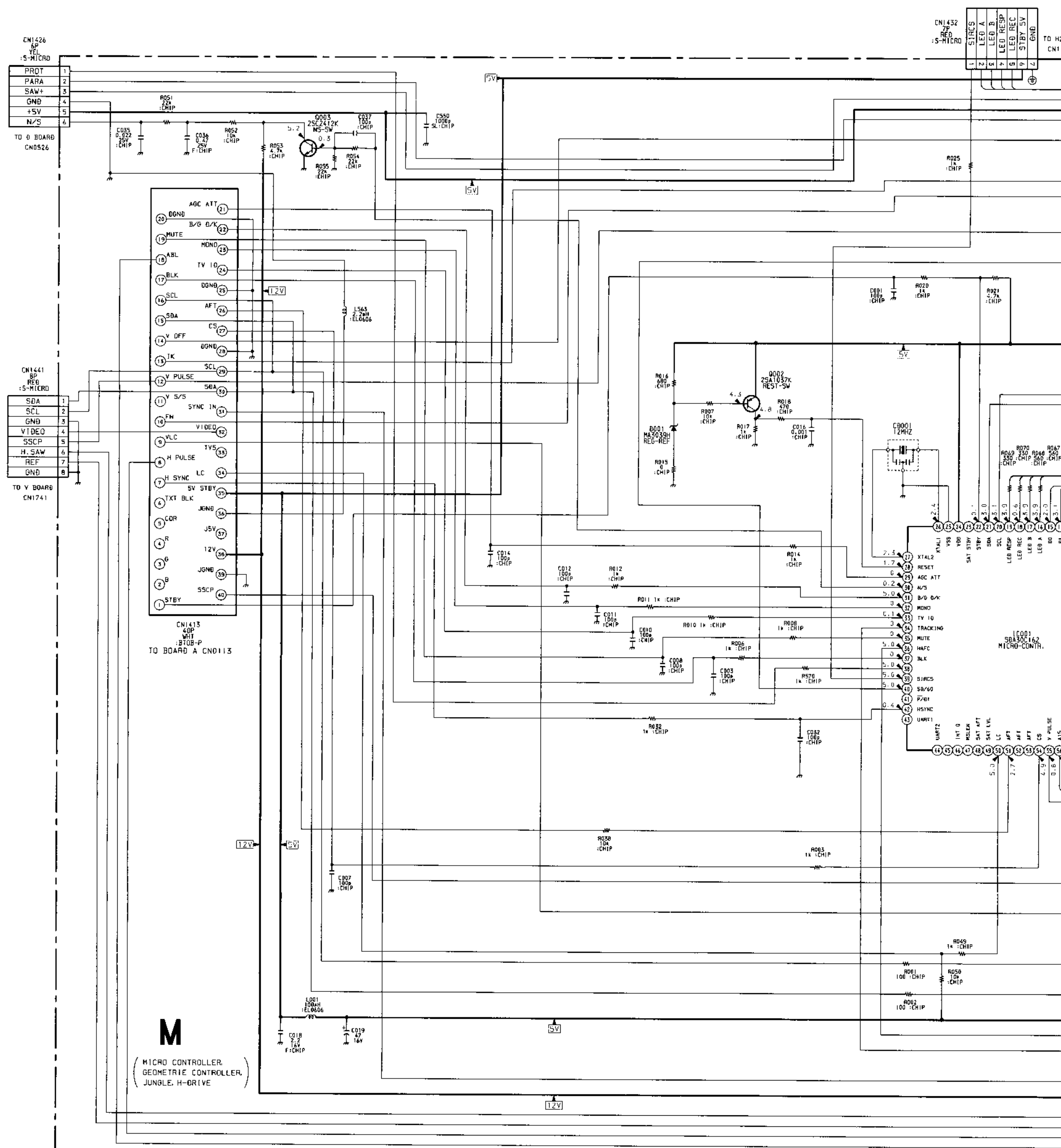

M
 MICRO CONTROLLER,
 GEOMETRIC CONTROLLER,
 JUNGLE, H-DRIVE

LED RESP
LED REC
STBY 5V
GND

TO H2 BOARD
CN1132

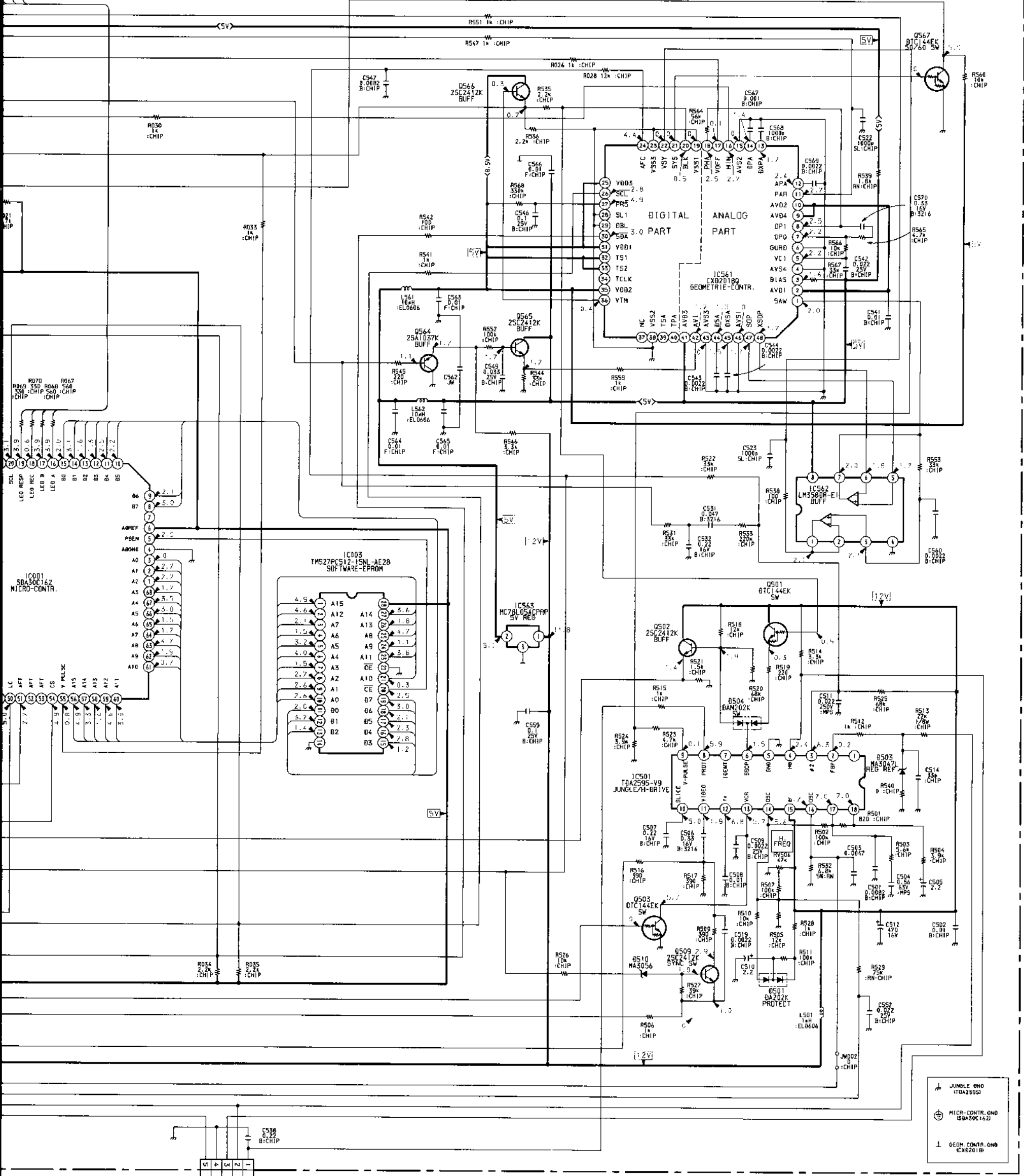

TO D BOARD
CN0506

ABL
GND
HB
H-PULSE
X-RAY

CN1406
SP
BLK
S-MICRO

- JUNGLE GND (TQA2595)
- MICR-CONTR. GND (SBA30C162)
- GEOM. CONTR. GND (CX820180)

M MICRO CONTROLLER,
GEOMETRIE CONTROLLER
JUNGLE, H-DRIVE

D H/V OUT, PIN OUT,
POWER SUPPLY

- M BOARD -

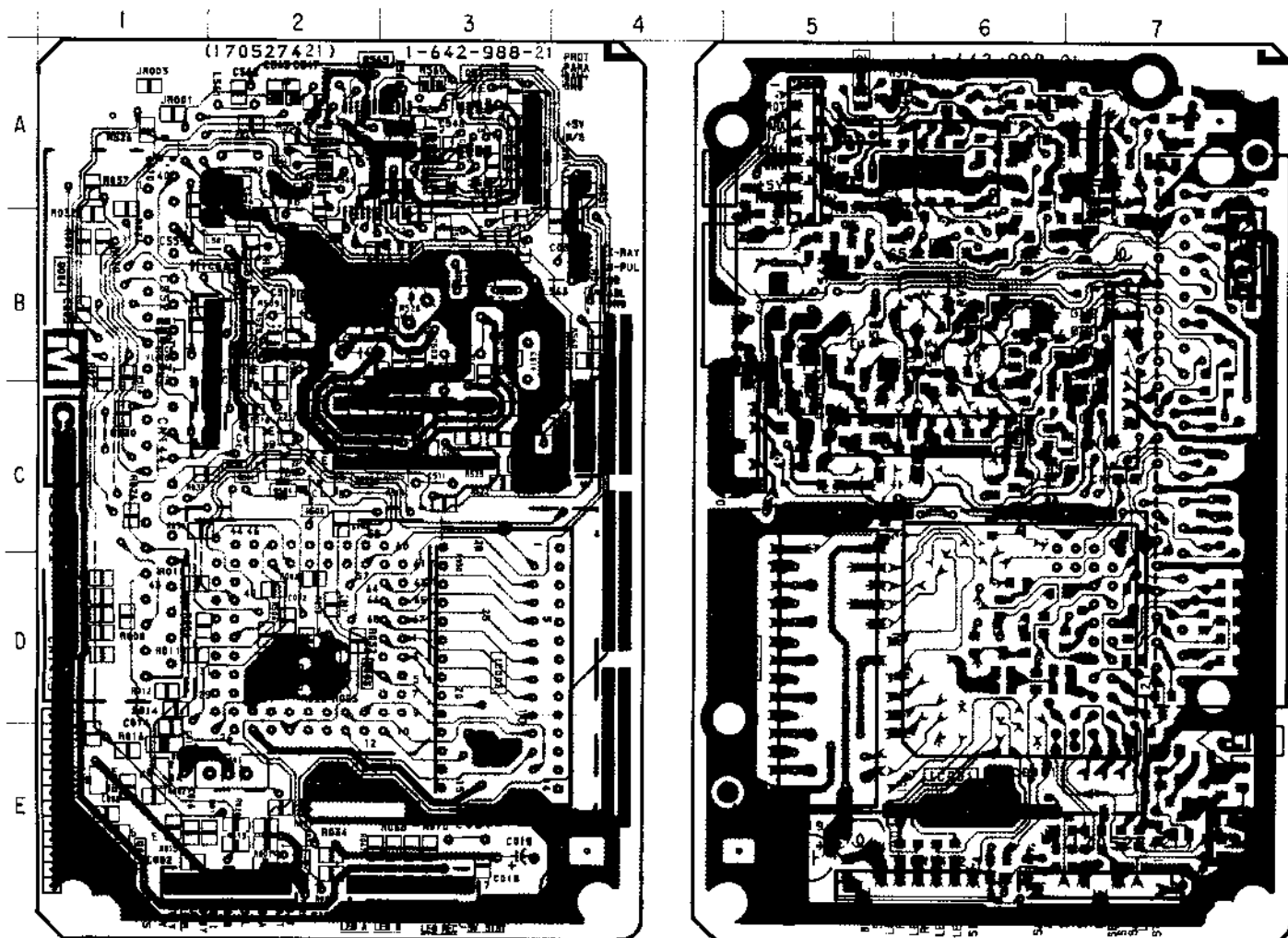

IC		DIODE	
IC001	D-2	D001	E-1
IC003	D-3	D501	B-2
IC501	C-3	D503	C-4
IC561	A-6	D504	C-2
IC562	A-5	D510	A-1
IC563	A-7		
TRANSISTOR		VARIABLE RESISTOR	
Q002	E-1	RV506	B-3
Q003	D-2		
Q501	C-2		
Q502	B-2		
Q503	C-2		
Q508	C-2		
Q509	B-2		
Q564	A-2		
Q565	A-2		
Q566	B-3		
Q567	A-3		

Note :

- : Pattern from the side which enables seeing.
- : Pattern of the rear side.

- D BOARD -

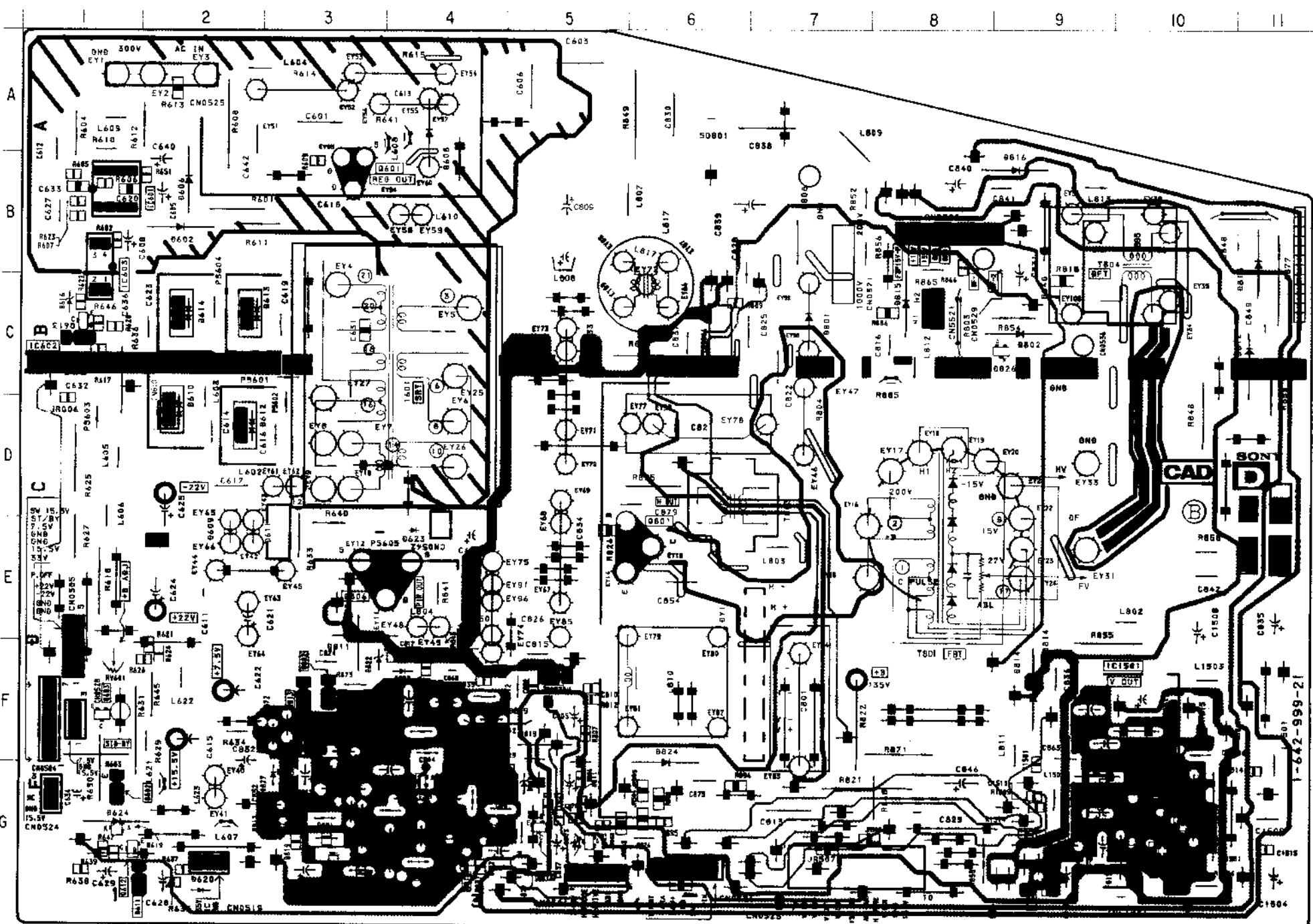

IC	
IC601	
IC602	
IC603	
IC801	
IC802	
IC803	
IC1501	
TRANS	
Q601	
Q602	
Q603	
Q611	
Q612	
Q613	
Q801	
Q802	
Q804	
Q805	
Q806	
Q807	
Q812	
Q813	
Q818	
Q1501	
Q1502	
Q1503	
Q1504	
DIO	
D602	
D606	
D608	
D609	
D610	
D611	

Note :

- : Pattern from the side which enables seeing.
- : Pattern of the rear side.

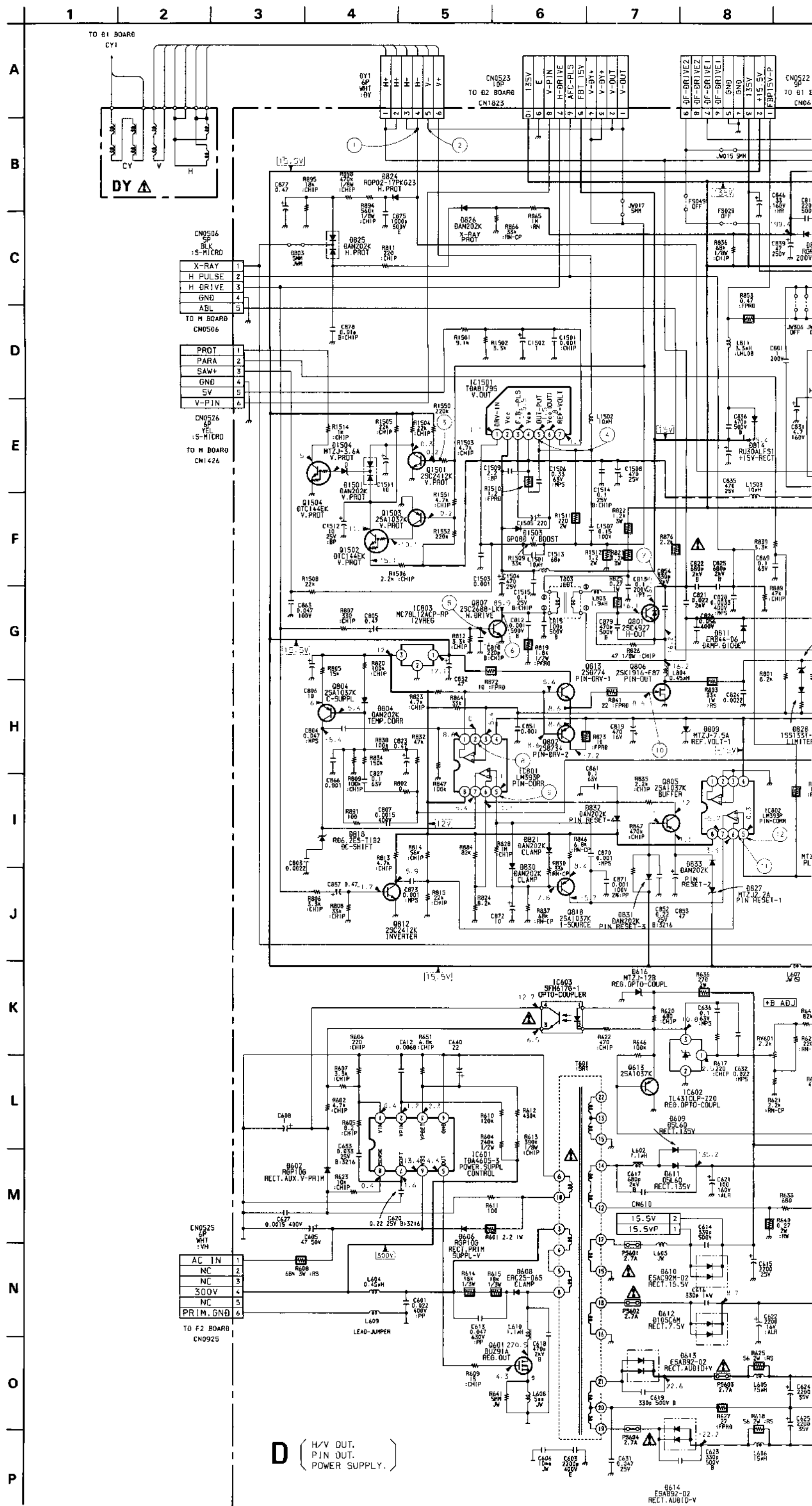

CN0506
5P
BLK
:S-MICRD

X-RAY	1
H PULSE	2
H DRIVE	3
GND	4
ABL	5

TO H BOARD
CN0506

CN0526
6P
YEL
:S-MICRD

PROT	1
PARA	2
SAW+	3
GND	4
5V	5
V-PIN	6

TO H BOARD
CN1426

CN0525
6P
WHT
:VH

AC IN	1
NC	2
NC	3
300V	4
NC	5
PRIM. GND	6

TO F2 BOARD
CN0925

IC	D612	D-2
IC601	B-1	C-2
IC602	C-1	B-1
IC603	B-1	G-1
IC801	F-3	G-2
IC802	F-4	G-1
IC803	F-3	C-7
IC1501	F-10	C-9
	D804	G-4
	D808	G-5
	D809	F-4
	D811	E-3
	D812	C-11
	D813	B-11
	D814	F-9
	D815	C-8
	D816	B-9
	D818	G-4
	D821	G-4
	D822	F-3
	D824	F-6
	D825	G-5
	D826	C-9
	D827	G-3
	D828	F-4
	D830	G-4
	D831	G-3
	D832	F-3
	D833	G-3
	D1501	G-9
	D1503	G-10
	D1504	G-9

TRANSISTOR		
Q601	B-3	
Q602	G-1	
Q603	F-1	
Q611	G-2	
Q612	G-1	
Q613	C-1	
Q801	E-6	
Q802	F-3	
Q804	G-4	
Q805	G-3	
Q806	E-3	
Q807	F-5	
Q812	G-5	
Q813	F-3	
Q818	G-4	
Q1501	G-10	
Q1502	G-10	
Q1503	G-10	
Q1504	G-9	

DIODE		
D602	B-2	
D606	B-2	
D608	A-4	
D609	E-2	
D610	D-2	
D611	E-2	

VARIABLE RESISTOR		
RV601	F-1	

D (H/V OUT, PIN OUT, POWER SUPPLY.)

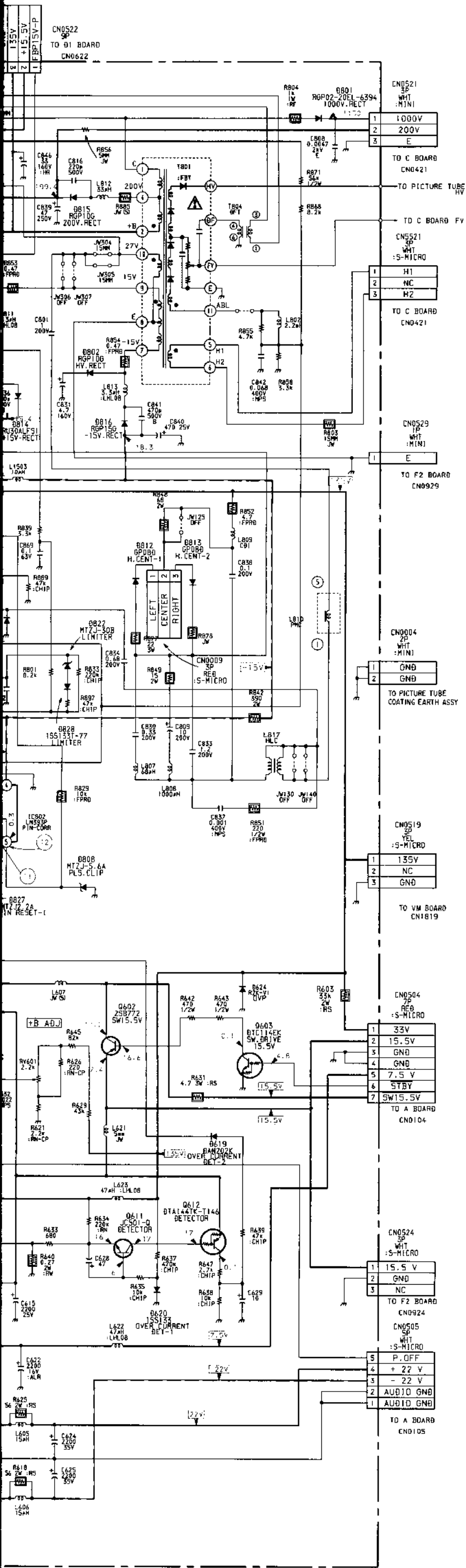

• WAVEFORMS D BOARD

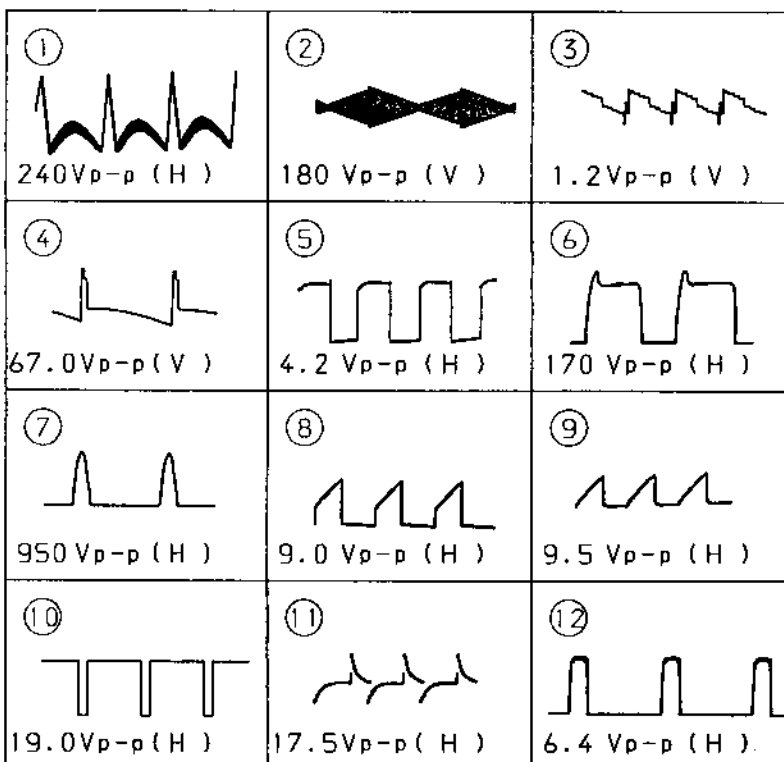

• D BOARD IC601 TDA4605-3

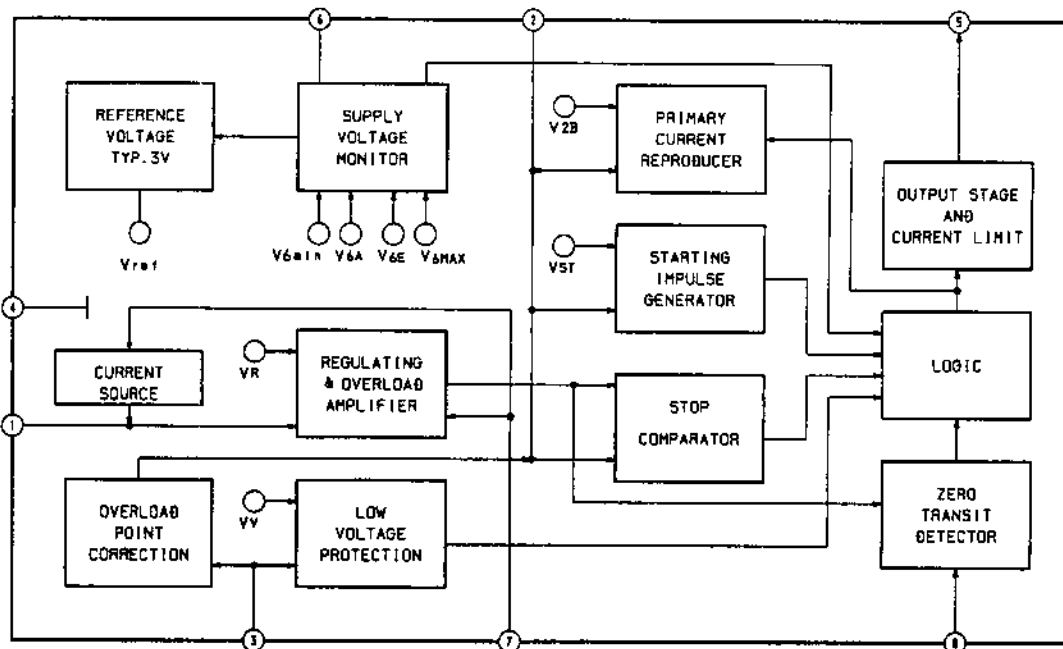

A
B
C
D
E
F
G
H
I
J
K
L
M
N
O
P

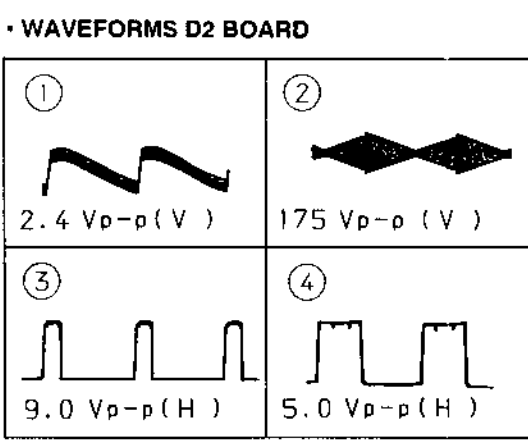
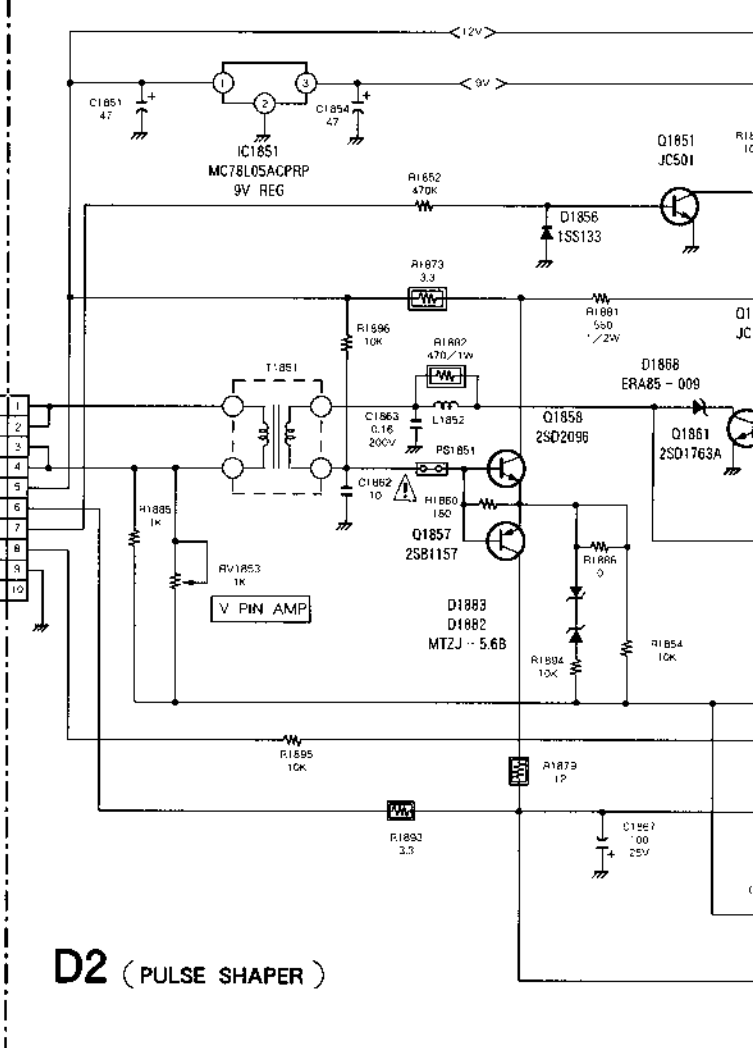
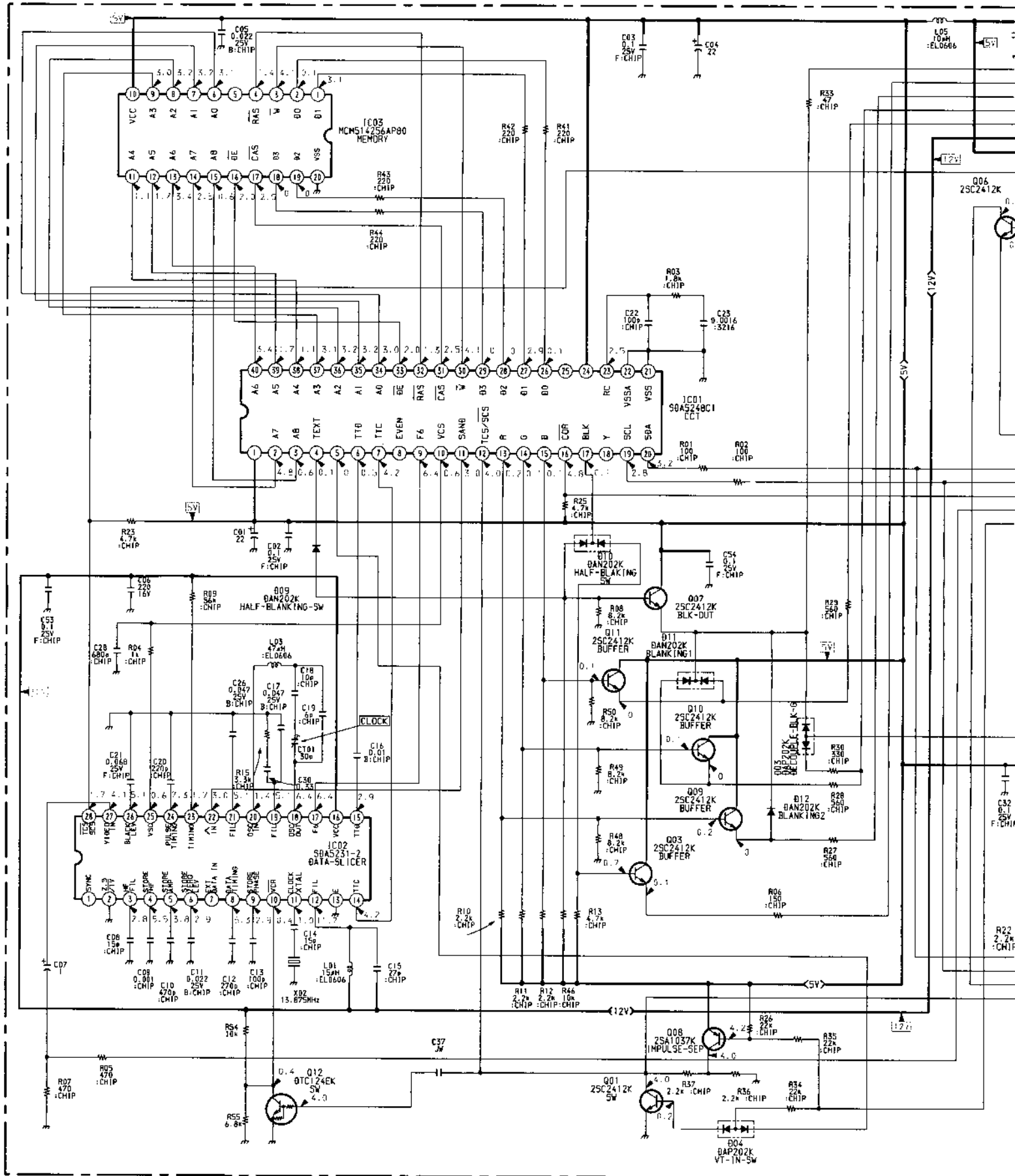

VP - OUT + 1
VP - OUT + 2 2
VP - OUT - 3
VP - OUT - 4
12V 5
FRT - 15 6
H - DRIVE 7
H - TPA2 8
GND 9
135V 10

CN1823 10P
TO D BOARD CN0523

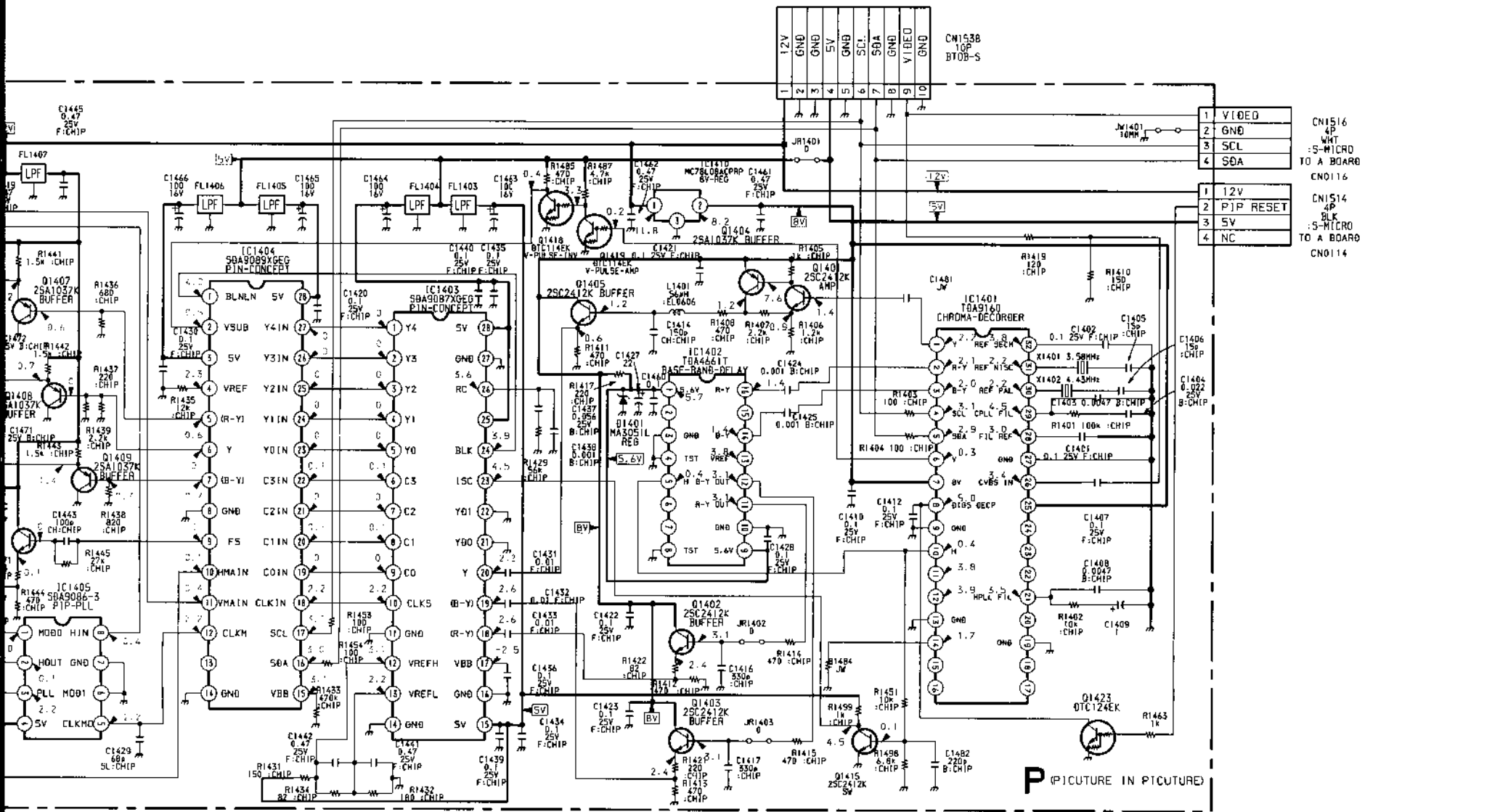

B-554274<AEP>-P..

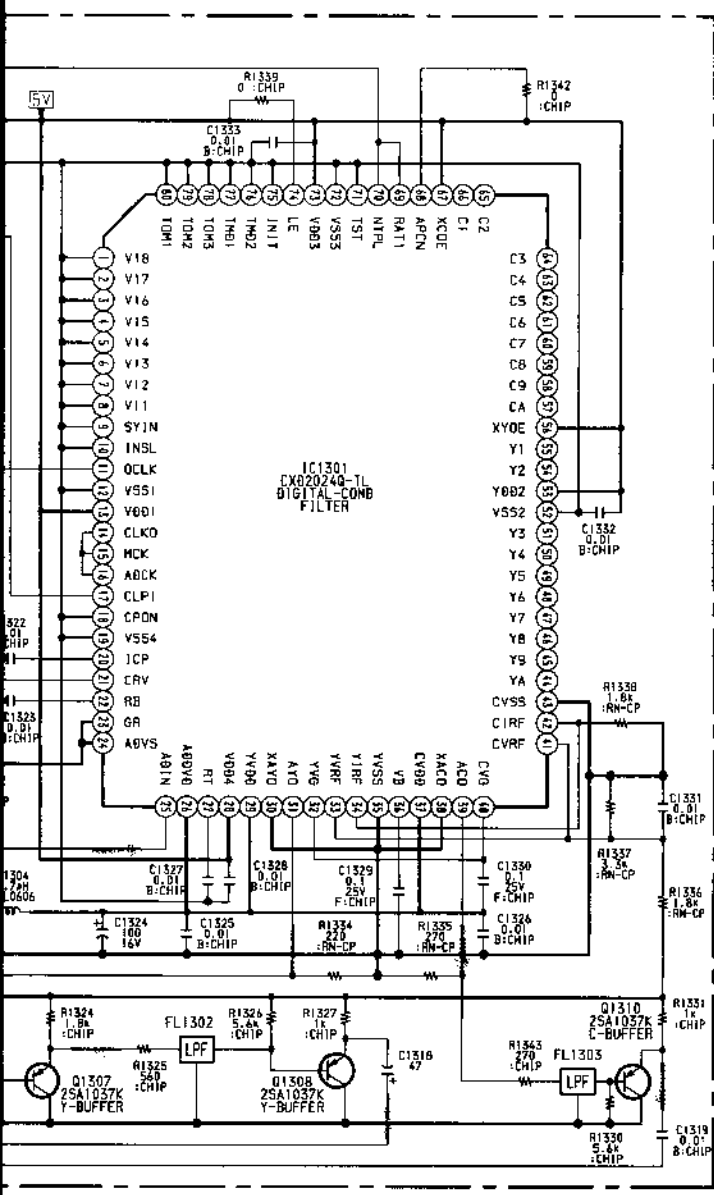

B-554274<AEP>-B..

• P BOARD IC1406 TDA8443A

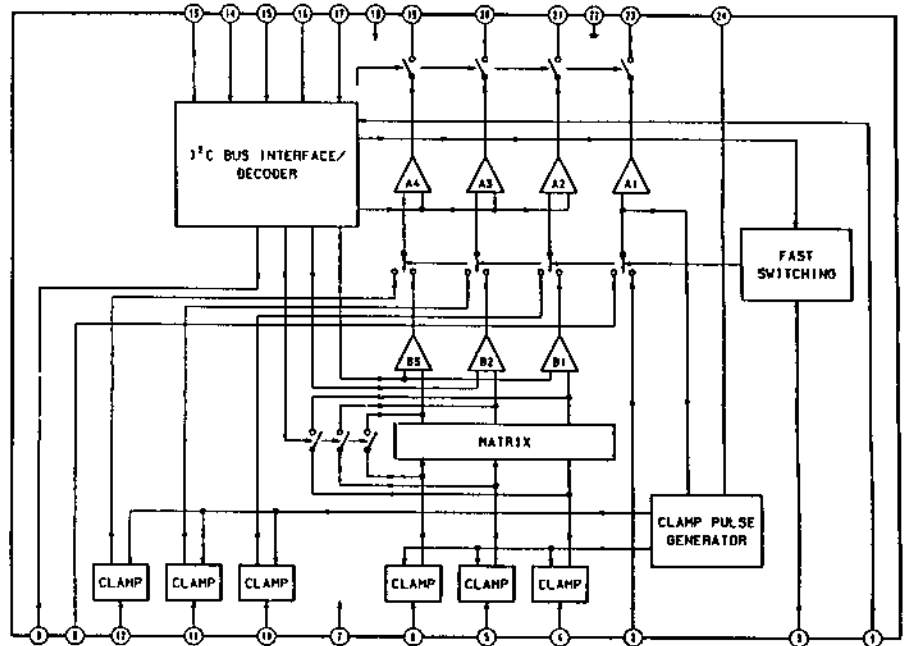

• P BOARD IC1402 TDA4660T

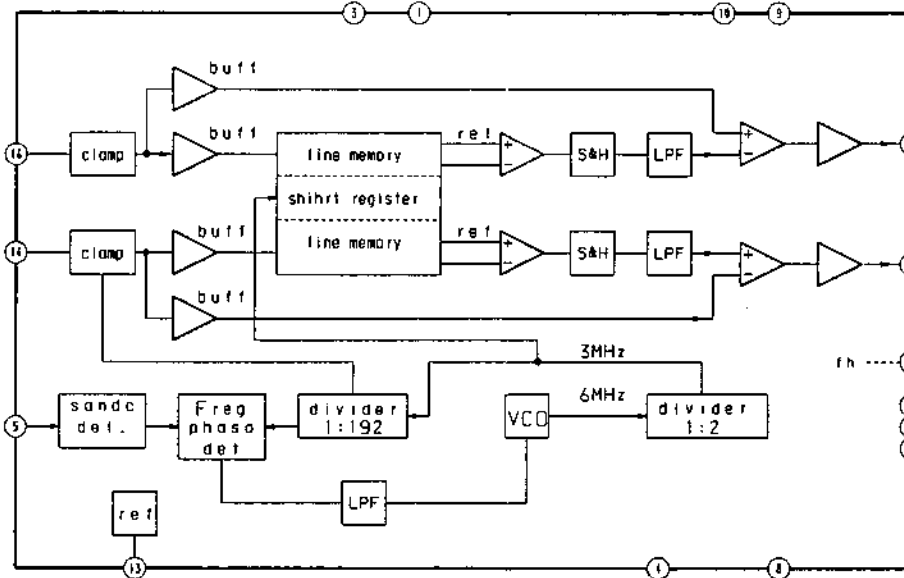

V [TEXT] **D2** [PULSE SHAPER] **P** [PICTURE IN PICTURE] **B** [DIGITAL COMB FILTER]

- V BOARD -

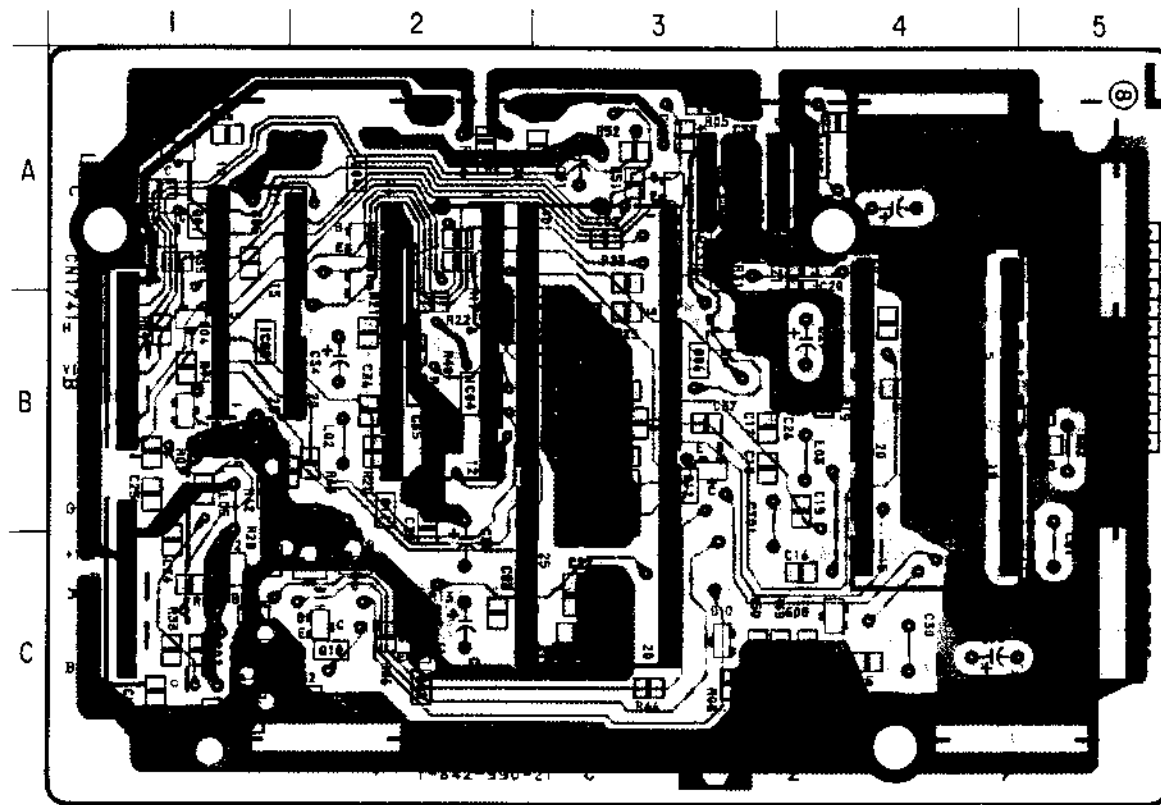

Note:

- : Pattern from the side which enables seeing.
- : Pattern of the rear side.

- D2 BOARD -

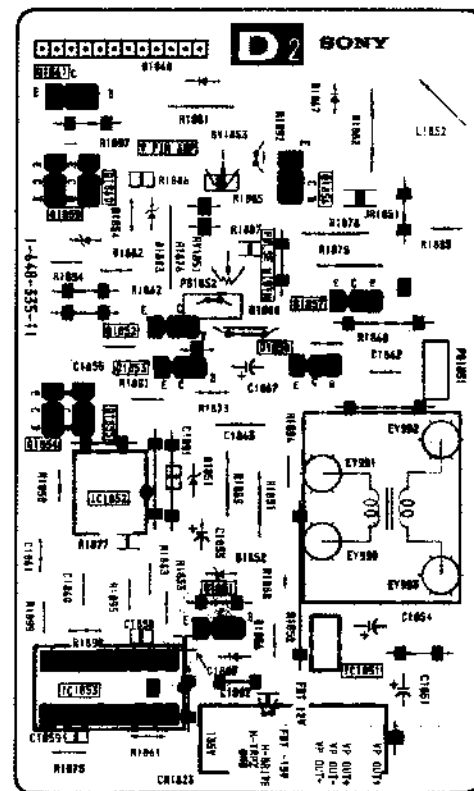

IC		DIODE	
IC01	B-3	D01	A-2
IC02	B-4	D03	B-1
IC03	B-1	D04	B-1
IC04	B-2	D09	C-4
IC05	A-4	D010	C-3
		D011	C-2
		D012	C-1
TRANSISTOR		TRIMMER	
Q01	A-1	CT01	B-3
Q03	C-2		
Q04	A-2		
Q06	B-3		
Q07	C-1		
Q08	A-1		
Q09	C-1		
Q010	C-2		
Q011	B-2		
Q012	B-3		

- P BOARD -

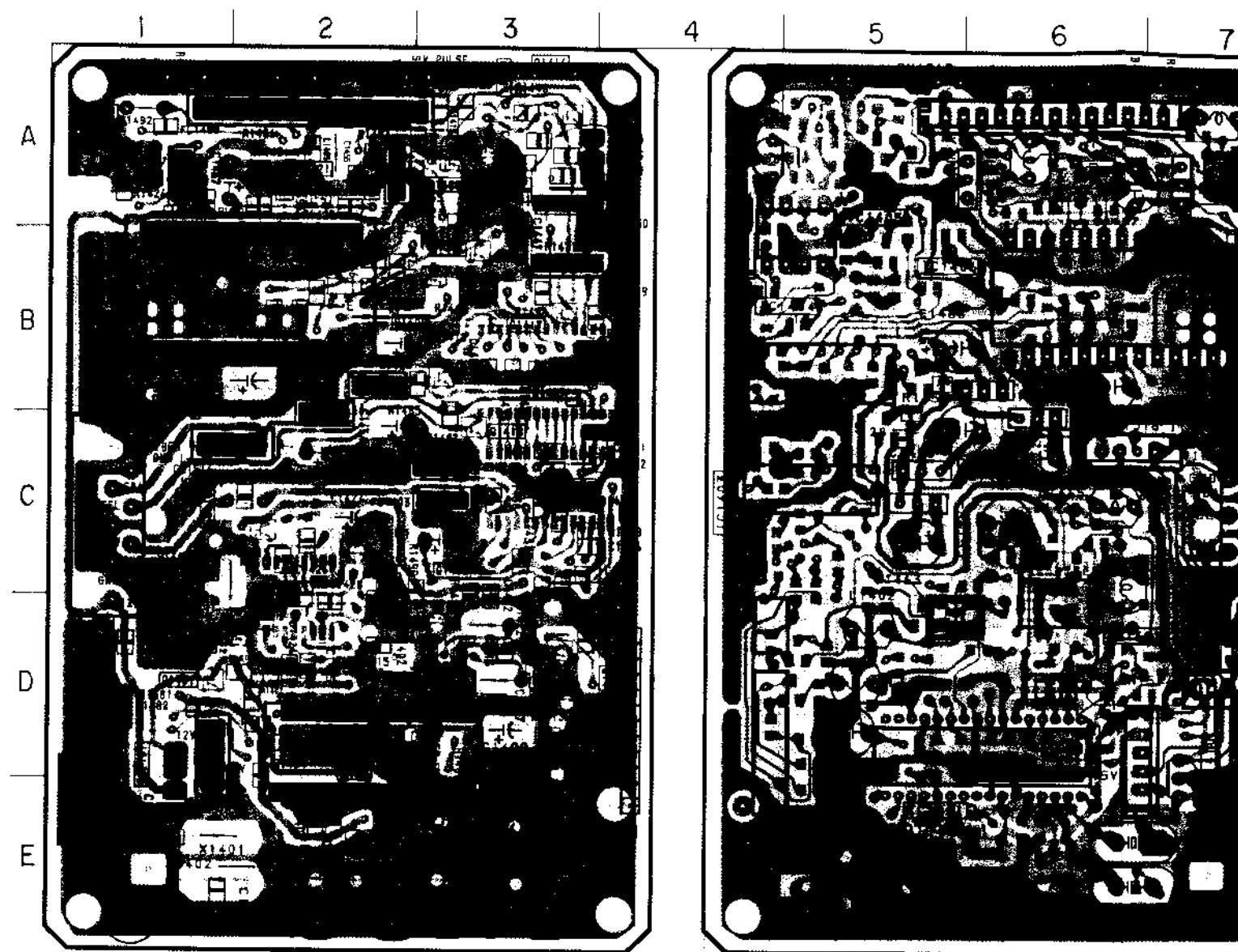

Note:

- : Pattern from the side which enables seeing.
- : Pattern of the rear side.

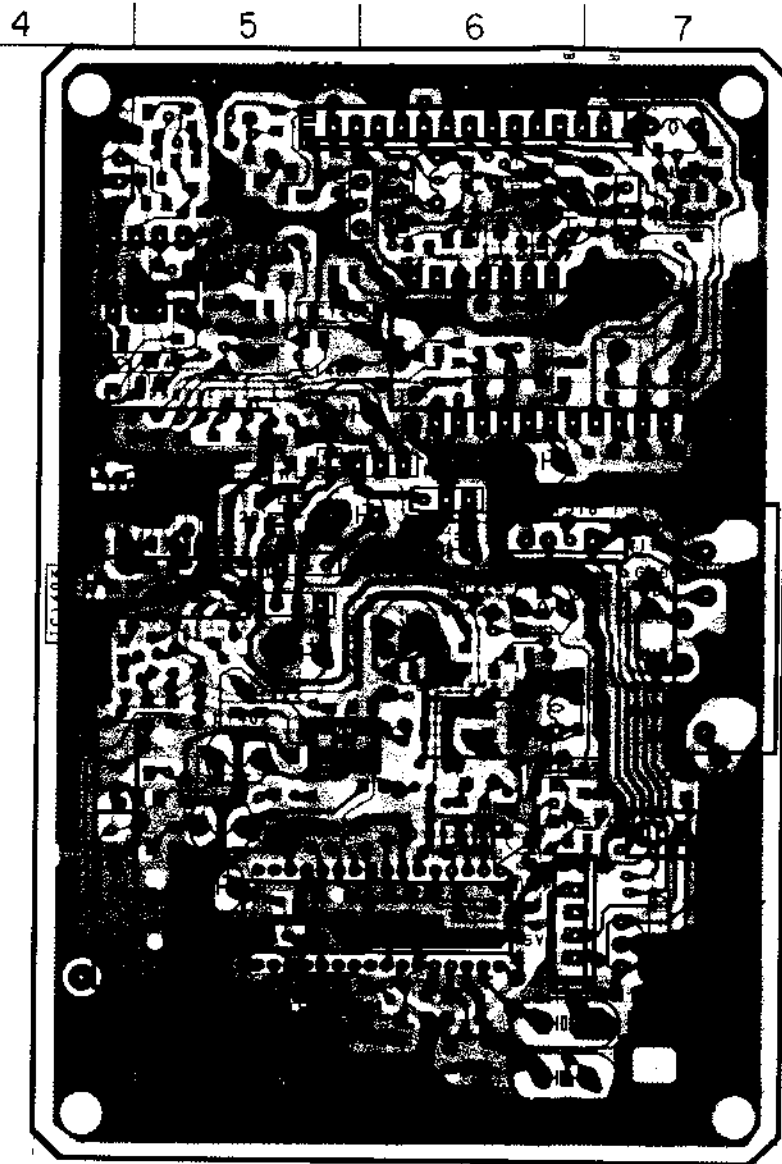

IC	
IC1401	D-2
IC1402	D-6
IC1403	C-5
IC1404	B-5
IC1405	B-3
IC1406	B-2
IC1410	D-1
IC1411	A-3
TRANSISTOR	
Q1401	D-1
Q1402	D-3
Q1403	D-3
Q1404	D-2
Q1405	C-2
Q1406	B-3
Q1407	A-2
Q1408	A-3
Q1409	B-3
Q1413	A-3
Q1414	A-3
Q1415	D-3
Q1416	A-3
Q1417	B-3
Q1418	B-3
Q1419	C-3
Q1421	A-2
Q1422	A-1
DIODED	
D1401	C-2

Note :

- : Pattern from the side which enables seeing.
- : Pattern of the rear side.

- B BOARD -

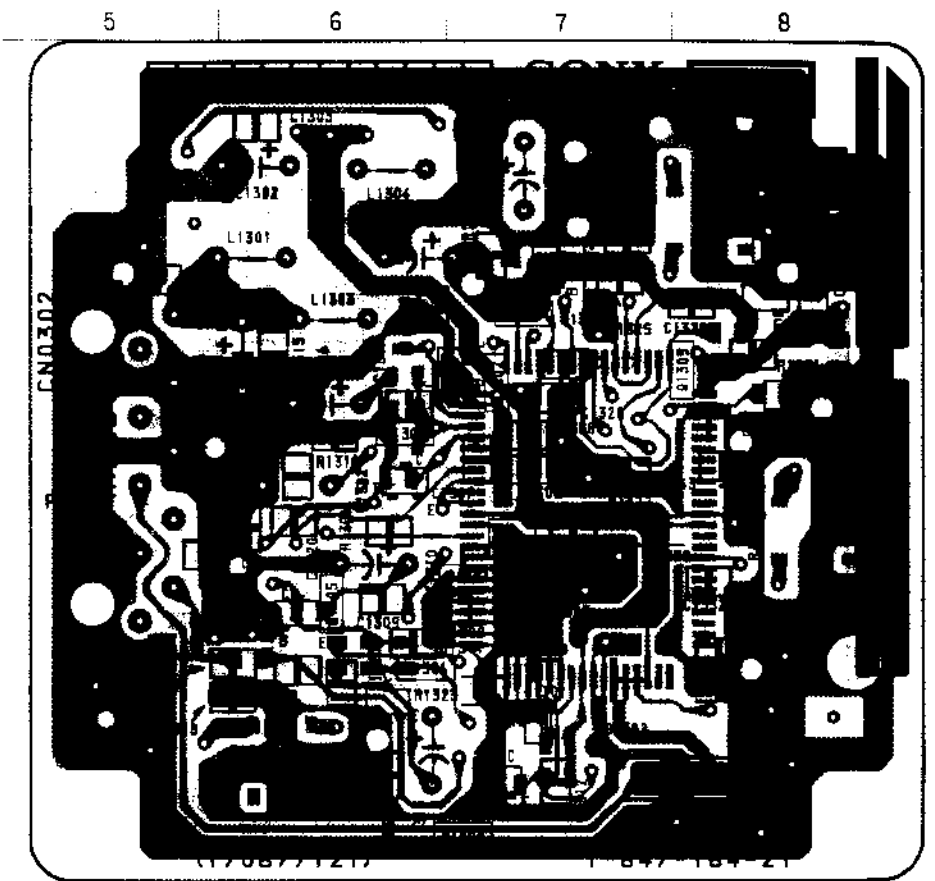
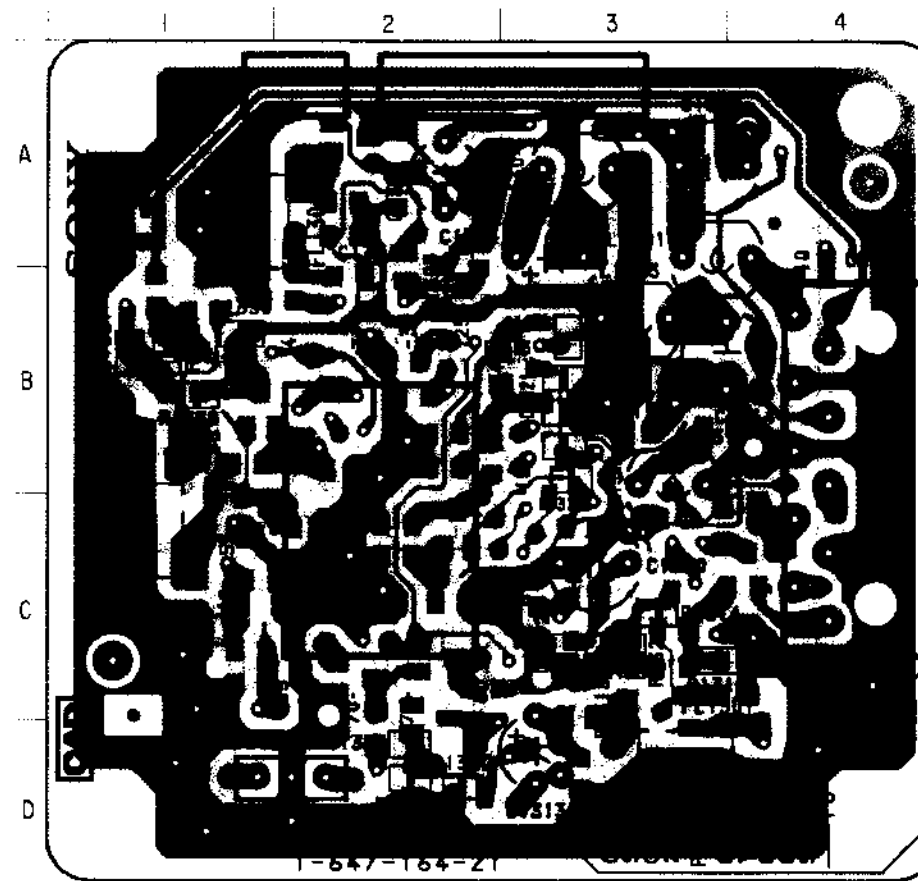

IC130	
Q1301	
Q1302	
Q1303	
Q1304	
Q1305	
Q1306	
Q1307	
Q1308	
Q1309	
Q1310	
D130	
D1301	

Note :

- : Pattern from the side which enables seeing.
- : Pattern of the rear side.

- B BOARD -

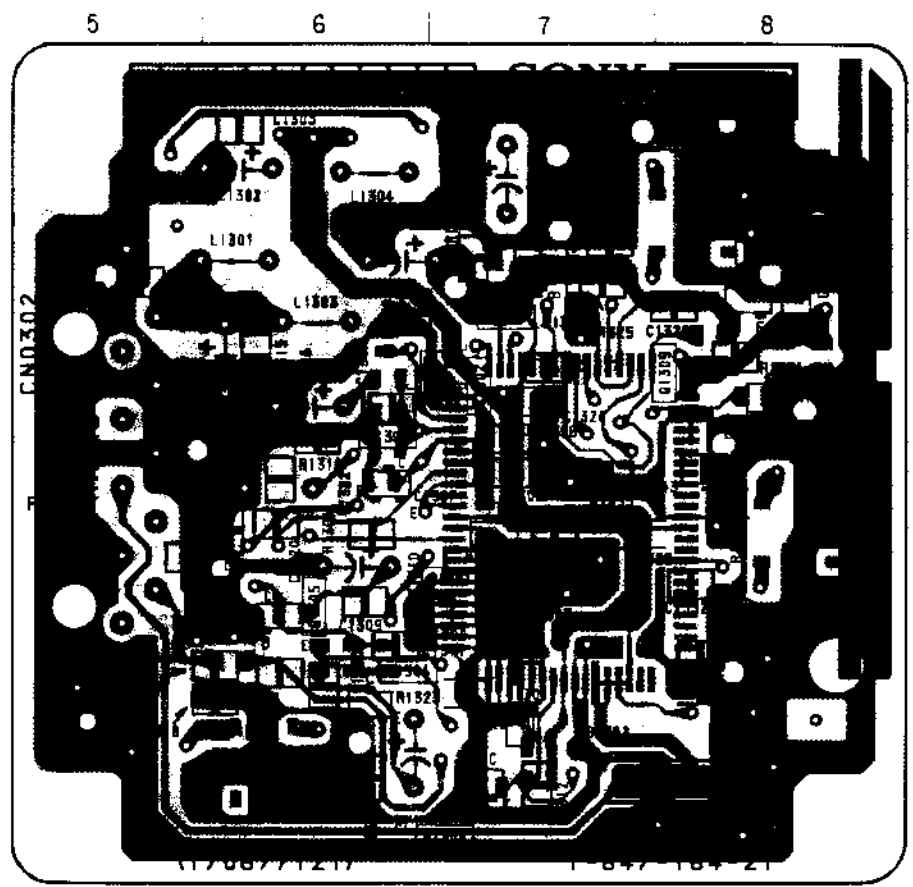
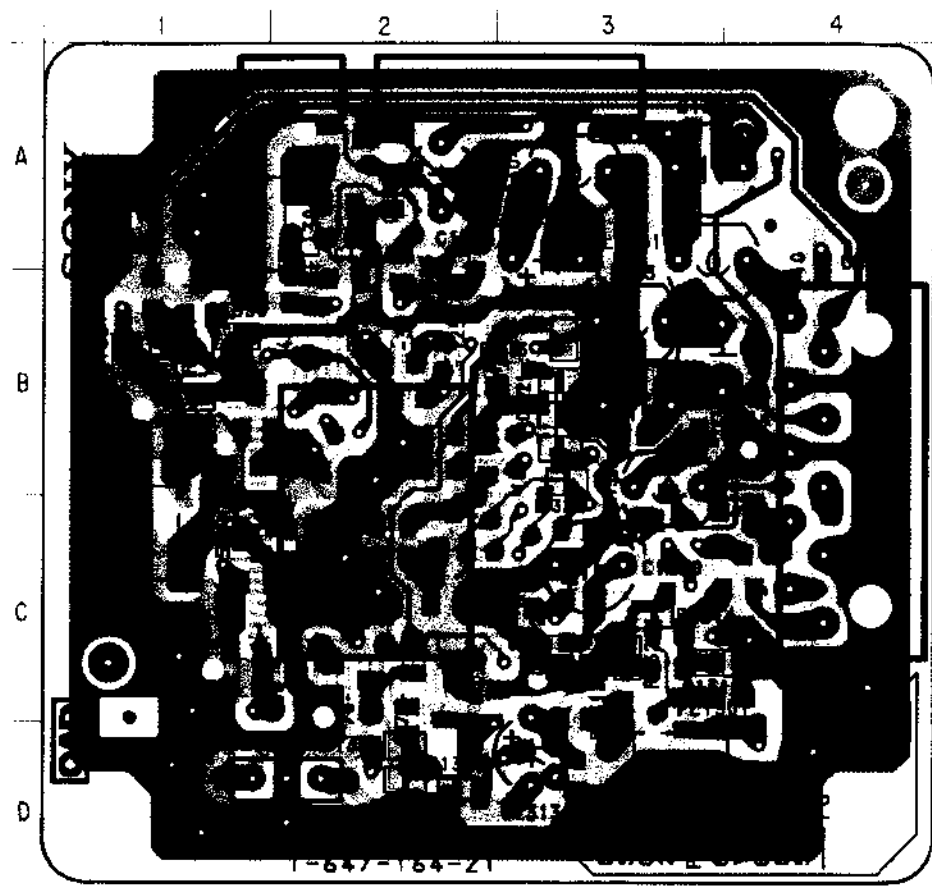

IC	
IC1301	C-2
TRANSISTOR	
Q1301	C-7
Q1302	B-7
Q1303	B-6
Q1304	D-7
Q1305	C-6
Q1306	C-6
Q1307	B-7
Q1308	A-7
Q1310	B-8
DIODE	
D1301	C-7

Note :

- : Pattern from the side which enables seeing.
- : Pattern of the rear side.

1 2 3 4 5 6 7 8 9 10 11 12 13 14 15 16

A
B
C
D
E
F
G
H
I
J

• A1 E
INC
ONK
CLKLPP
CLKESC
• A1 E
1
2
3
4
5
6
7
8
9

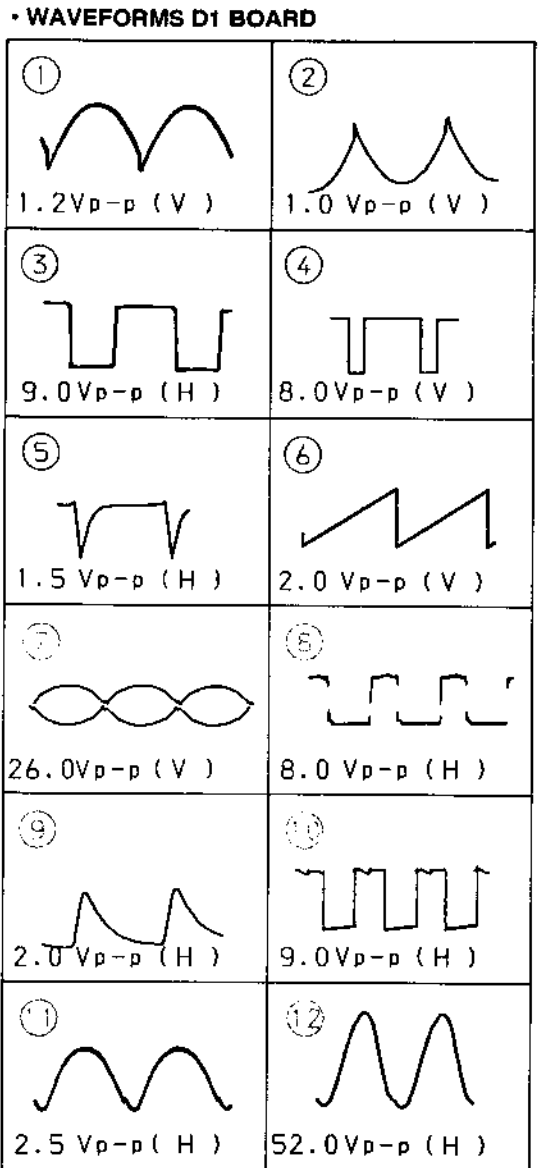
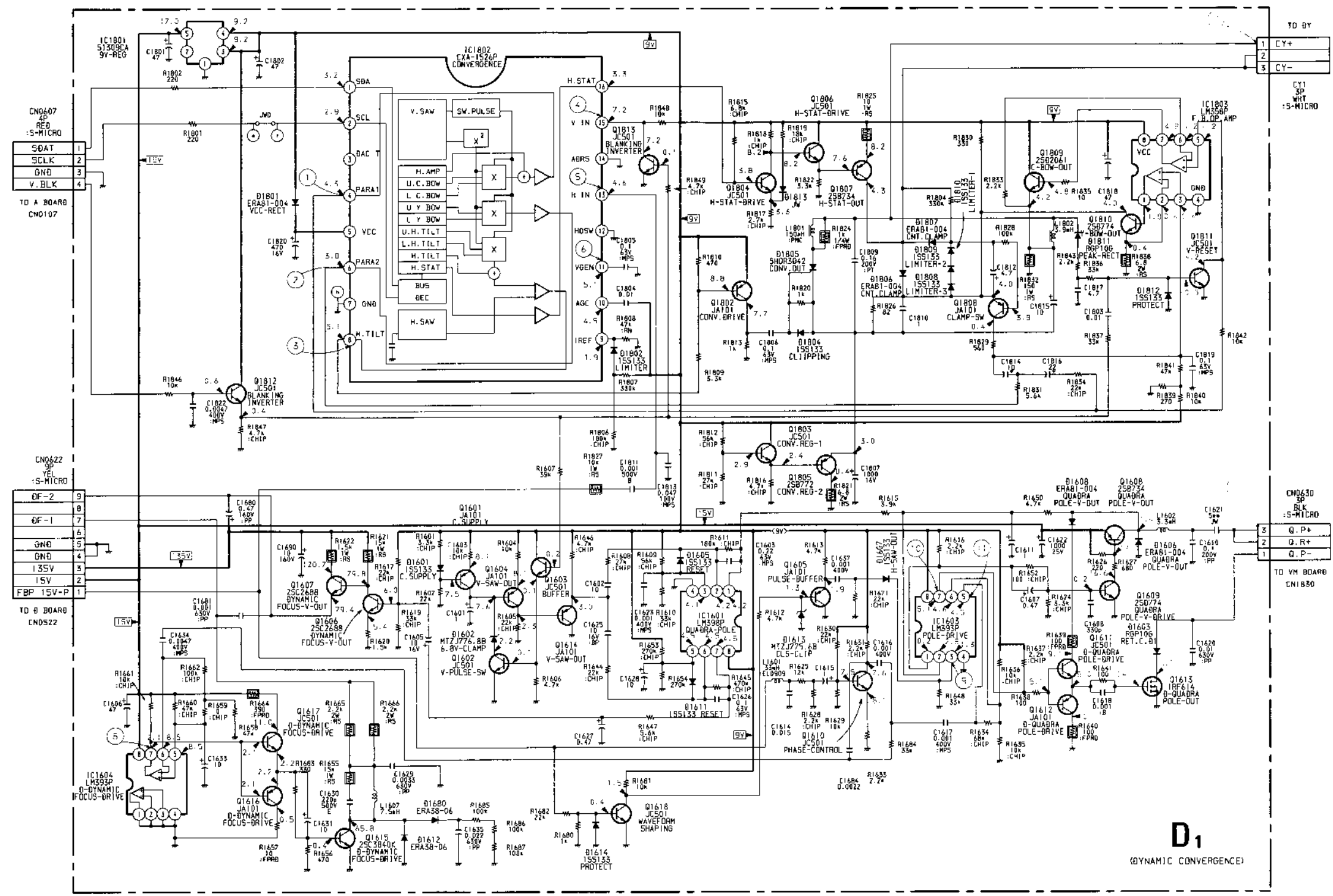

TO BY
CY+
CY-
CY1
3P
WHT
:S-MICRO

• WAVEFORMS D1 BOARD

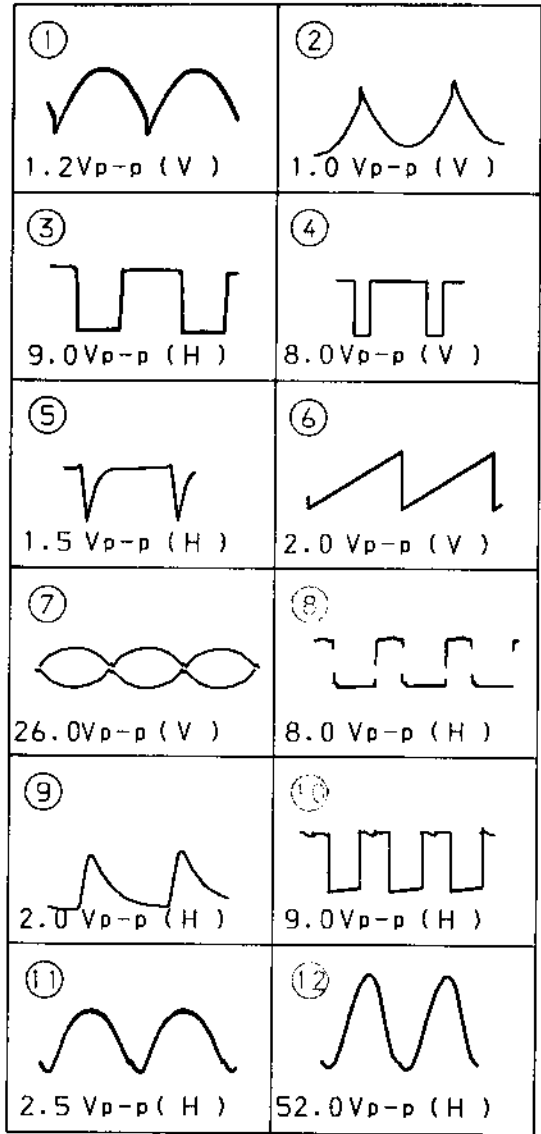

CN0630
3P
BLK
:S-MICRO
Q.P+
Q.R+
Q.P-
TO VM BOARD
CN1850

• A1 BOARD IC1101 TDA8732

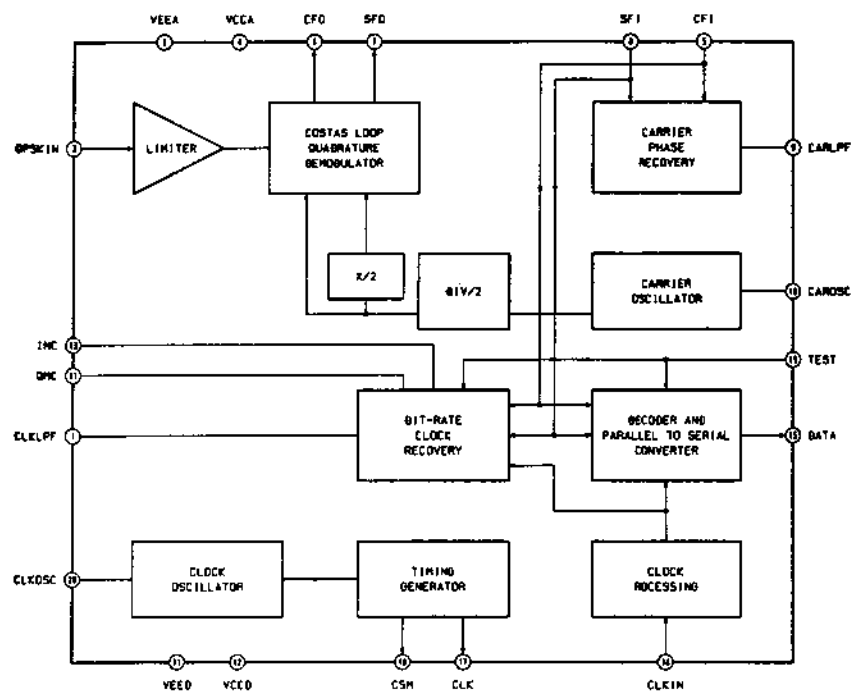

• A1 BOARD IC1102 SAA7282P

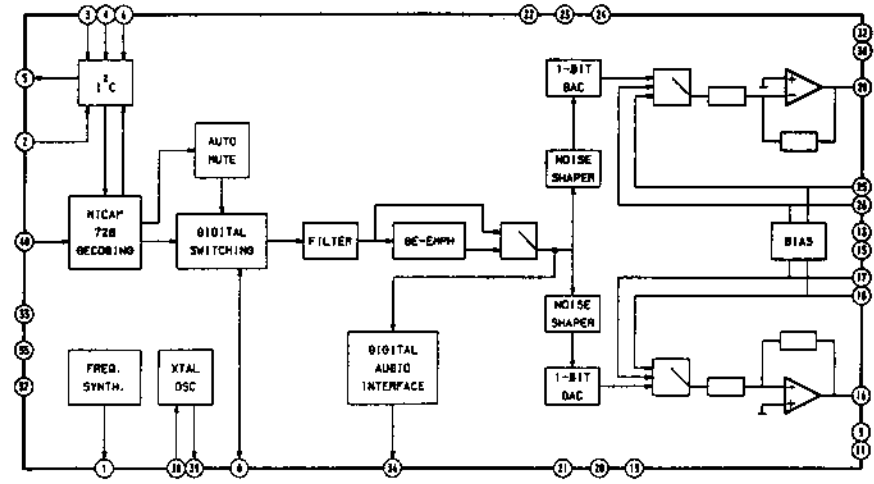

A1 BOARD * MARK

	KV-S3413E	KV-S3412U
BP1101	5.850MHz	6.552MHz
C1159	-	47P : CHIP
CF1101	-	6.0MHz
CF1102	5.5MHz	-
JR1101	0 : CHIP	-
L1105	-	15 μH
X1102	11.700MHz	13.104MHz

KV-S3412U/S3413E only

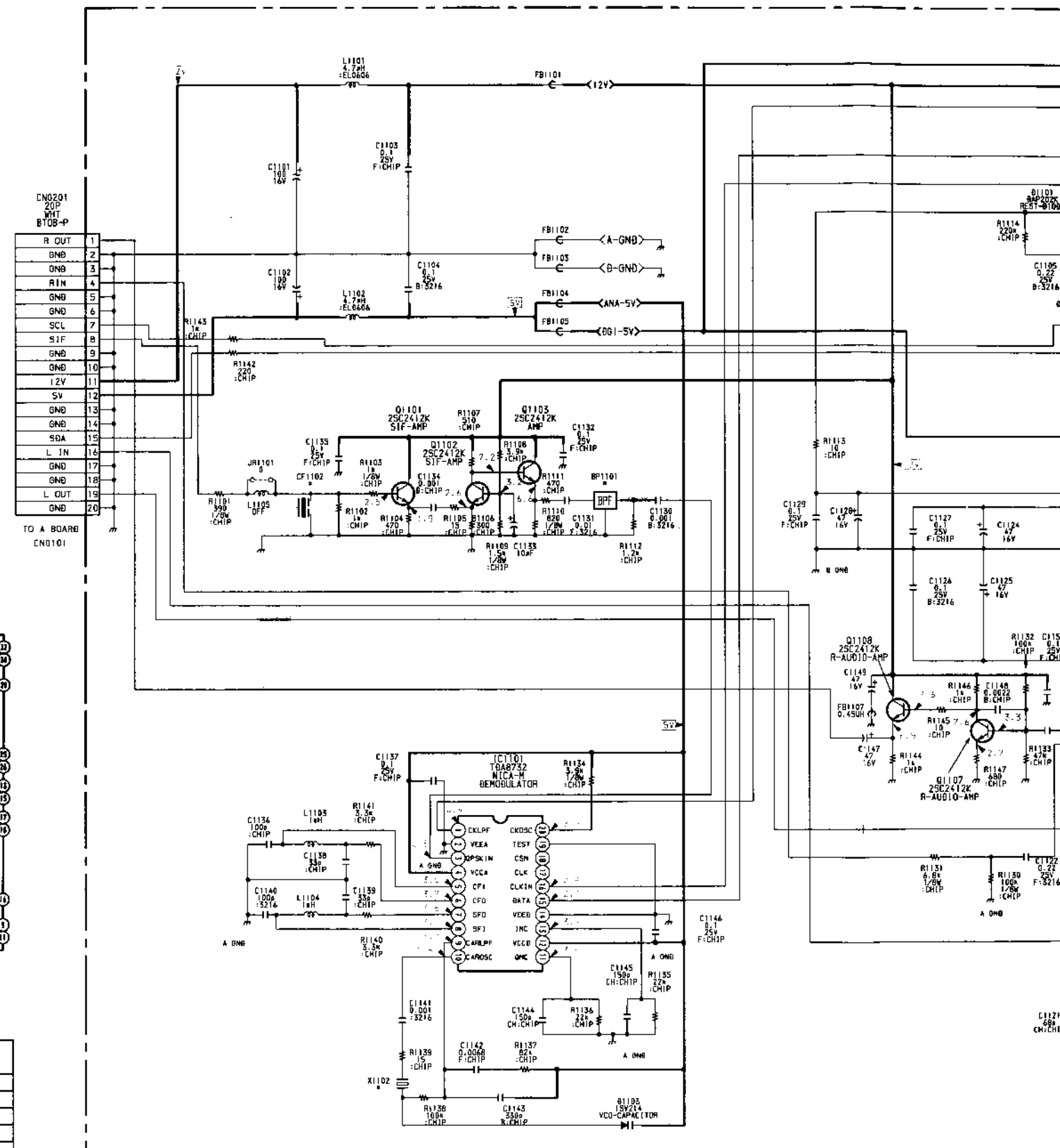

KV-S3412U/S3413E only

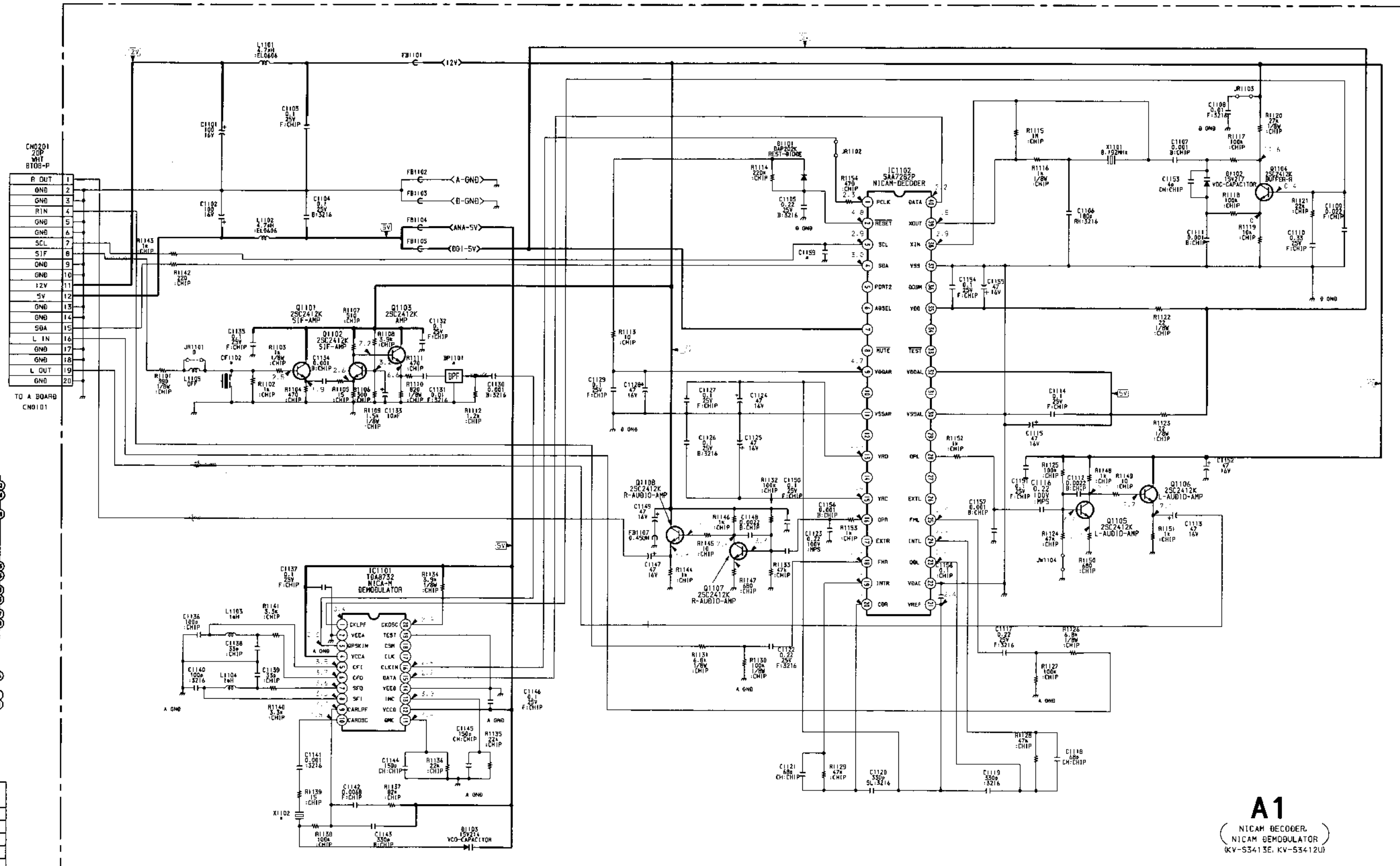
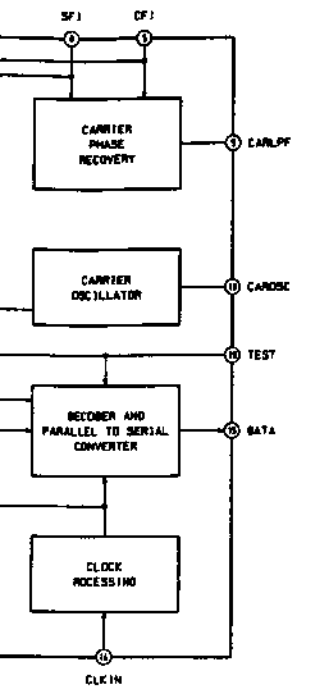

ARD * MARK

KV-S3413E	KV-S3412U
5.850MHz	6.552MHz
-	47P : CHIP
5.5MHz	6.0MHz
0 : CHIP	-
-	15 μ H
11.700MHz	13.104MHz

A1
 (NICAM DECODER,
 NICAM DEMODULATOR)
 (KV-S3413E, KV-S3412U)

D1 [DYNAMIC CONVERGENCE] **A1** [NICAM DECODER, NICAM DEMODULATOR] KV-S3412U/S3413E only

- D1 BOARD -

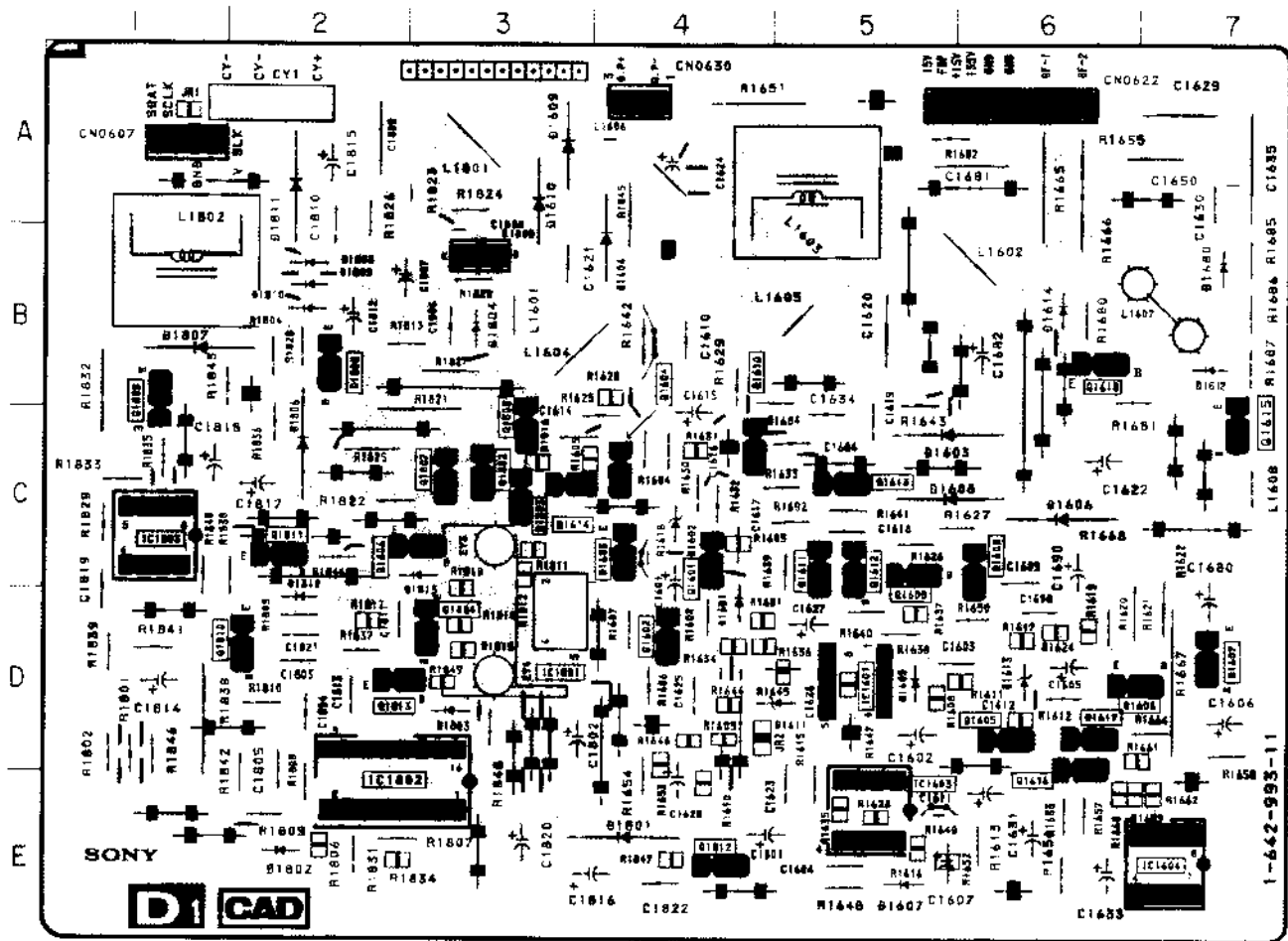

IC	Q1807	C-3
	Q1808	B-2
	Q1809	B-1
	Q1810	D-2
	Q1811	C-2
	Q1812	E-4
	Q1813	D-2
	DIODE	
	D1601	D-4
	D1602	C-4
	D1603	C-5
	D1605	D-5
	D1606	C-6
	D1607	D-5
	D1608	C-5
	D1611	D-5
	D1612	B-7
	D1613	D-6
	D1614	B-6
	D1680	B-7
	D1801	E-4
	D1802	E-2
	D1804	B-3
	D1805	B-3
	D1806	C-2
	D1807	B-1
	D1808	B-2
	D1809	B-2
	D1810	B-2
	D1811	A-2
	D1812	D-2
	D1813	C-3
	TRANSISTOR	
Q1601	C-4	
Q1602	D-4	
Q1603	C-4	
Q1604	C-4	
Q1605	D-6	
Q1606	D-6	
Q1607	D-7	
Q1608	C-5	
Q1609	C-6	
Q1610	C-4	
Q1611	C-5	
Q1612	C-5	
Q1614	C-3	
Q1615	C-7	
Q1616	D-6	
Q1617	D-6	
Q1618	B-6	
Q1802	C-3	
Q1803	C-3	
Q1804	D-3	
Q1805	C-3	
Q1806	C-3	

- A1 BOARD - (KV-S3412U/S3413E only)

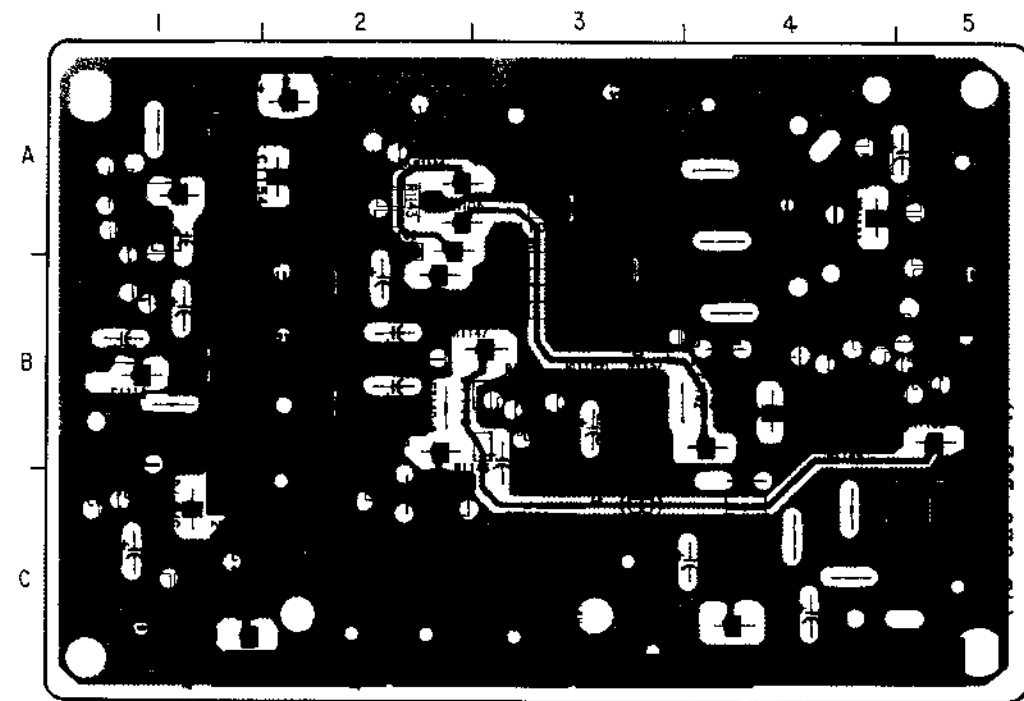

IC	IC1101	A-3
	IC1102	B-2
	TRANSISTOR	
Q1101	B-4	
Q1102	B-5	
Q1103	B-5	
Q1104	A-1	
Q1105	B-1	
Q1106	C-1	
Q1107	B-3	
Q1108	B-3	
	DIODE	
D1101	A-2	
D1102	A-1	
D1103	B-4	

Note:

- : Pattern from the side which enables seeing.
- : Pattern of the rear side.

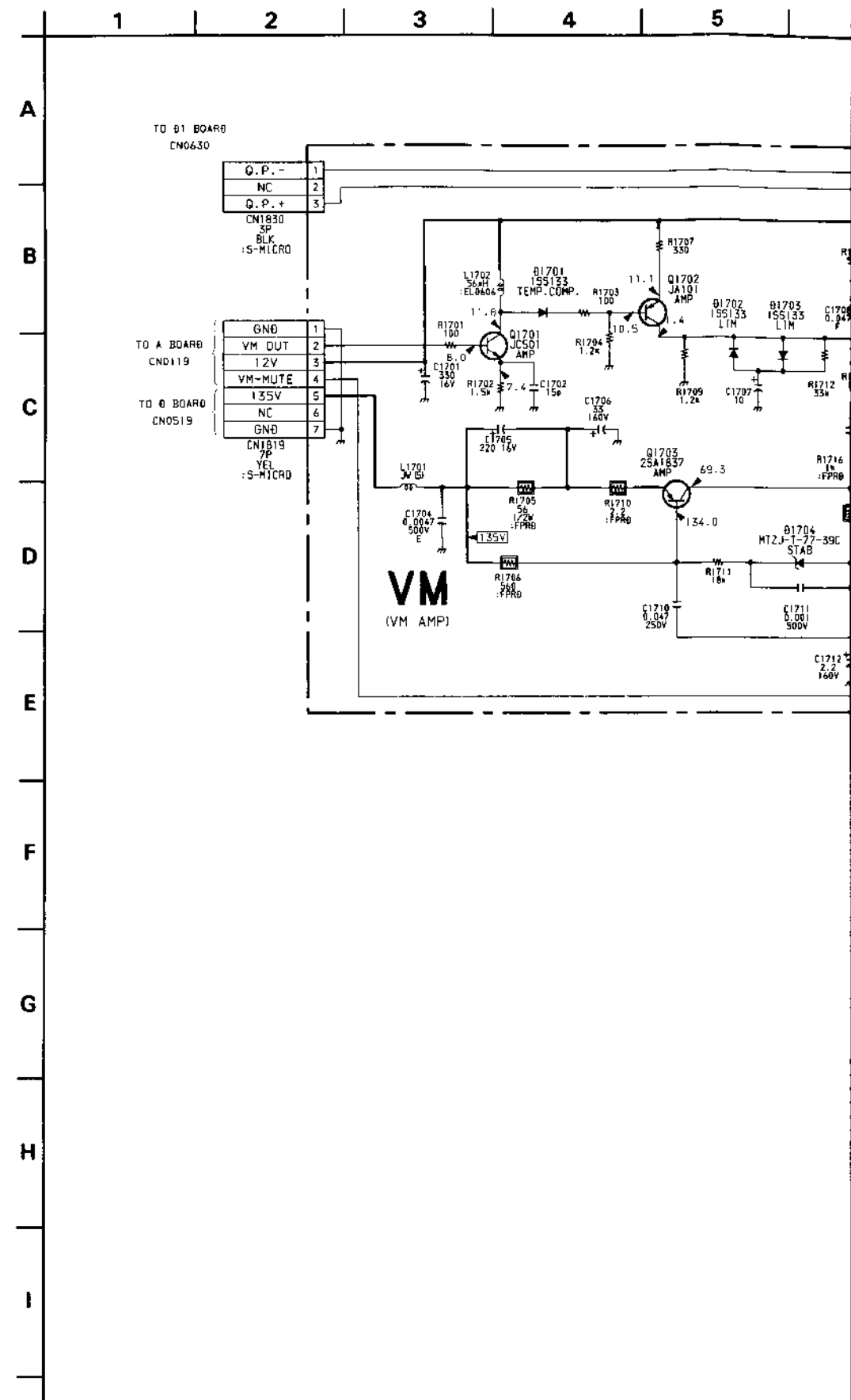

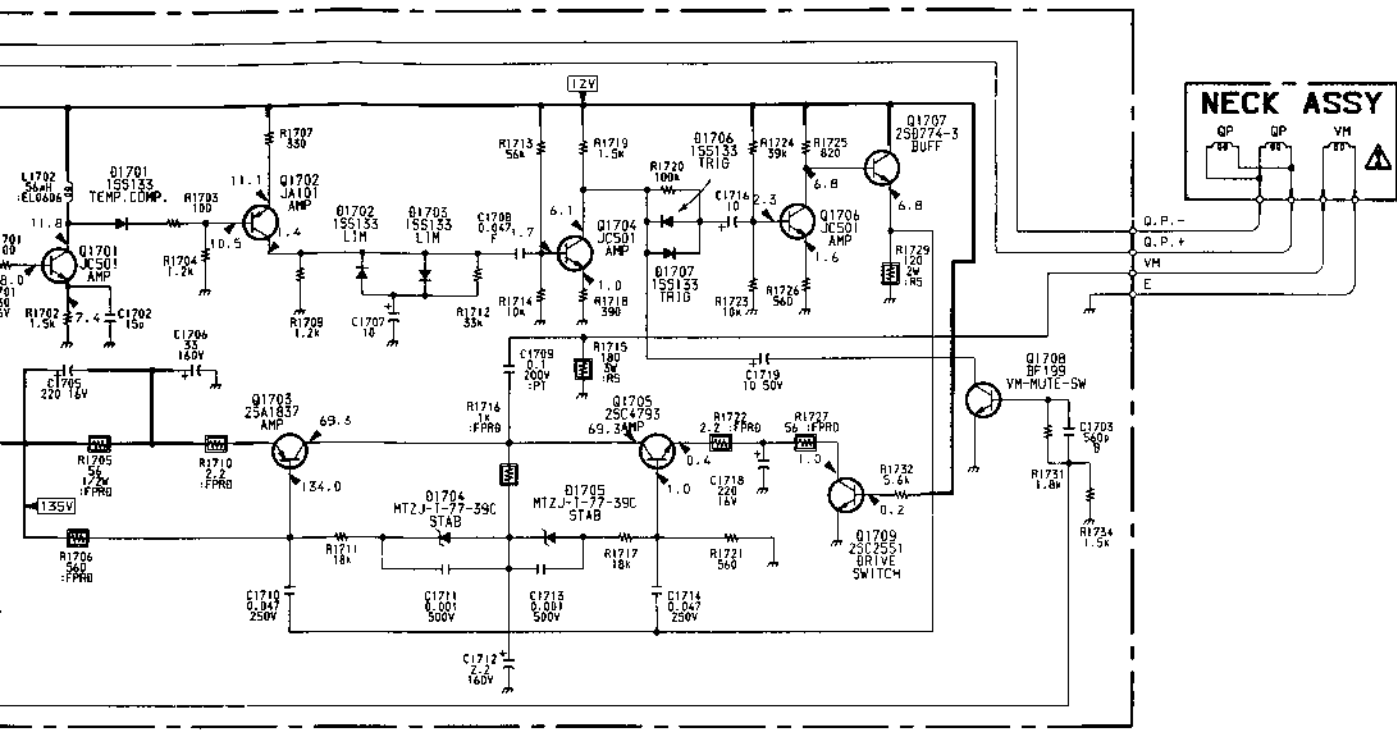

B-SS4274<AEP>-VM.

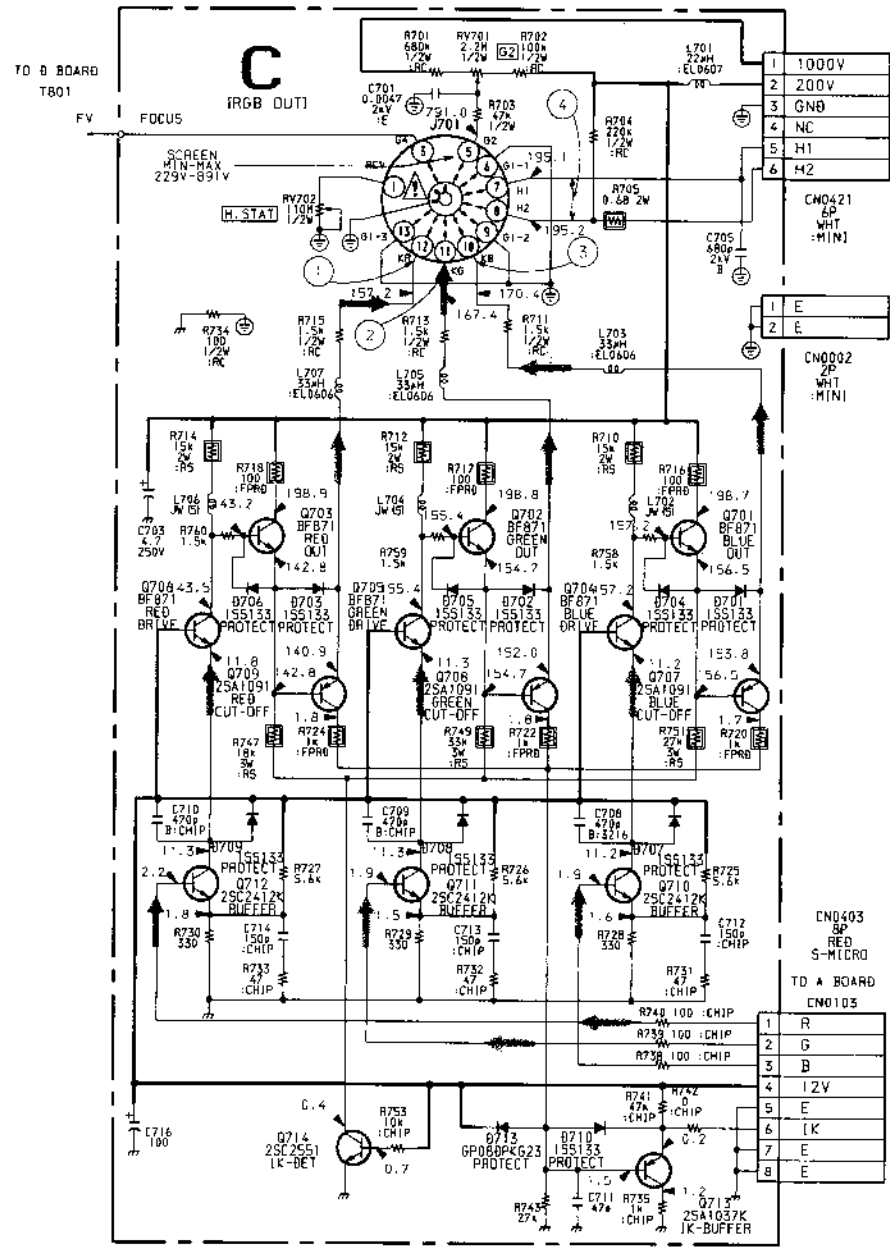

B-SS4274<AEP>-C.

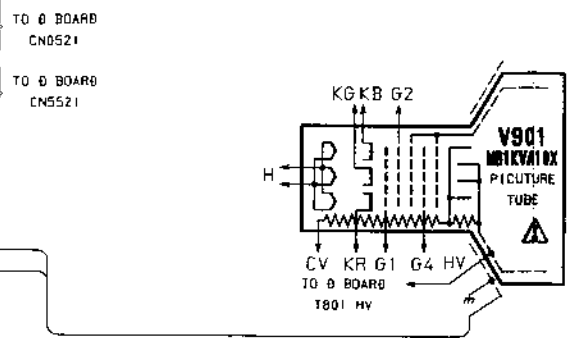

• WAVEFORMS C BOARD

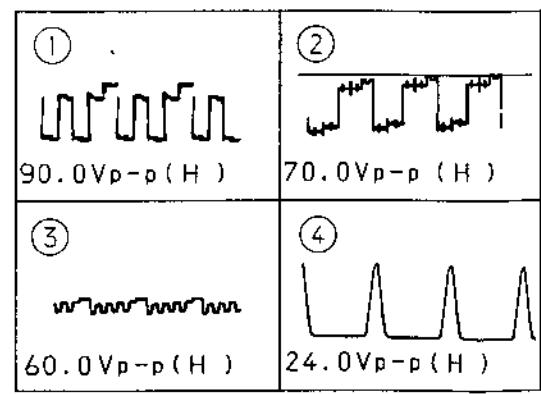

IFH395 (KV-S3411D/S3413E only)

IFH395 (KV-S3411B only)

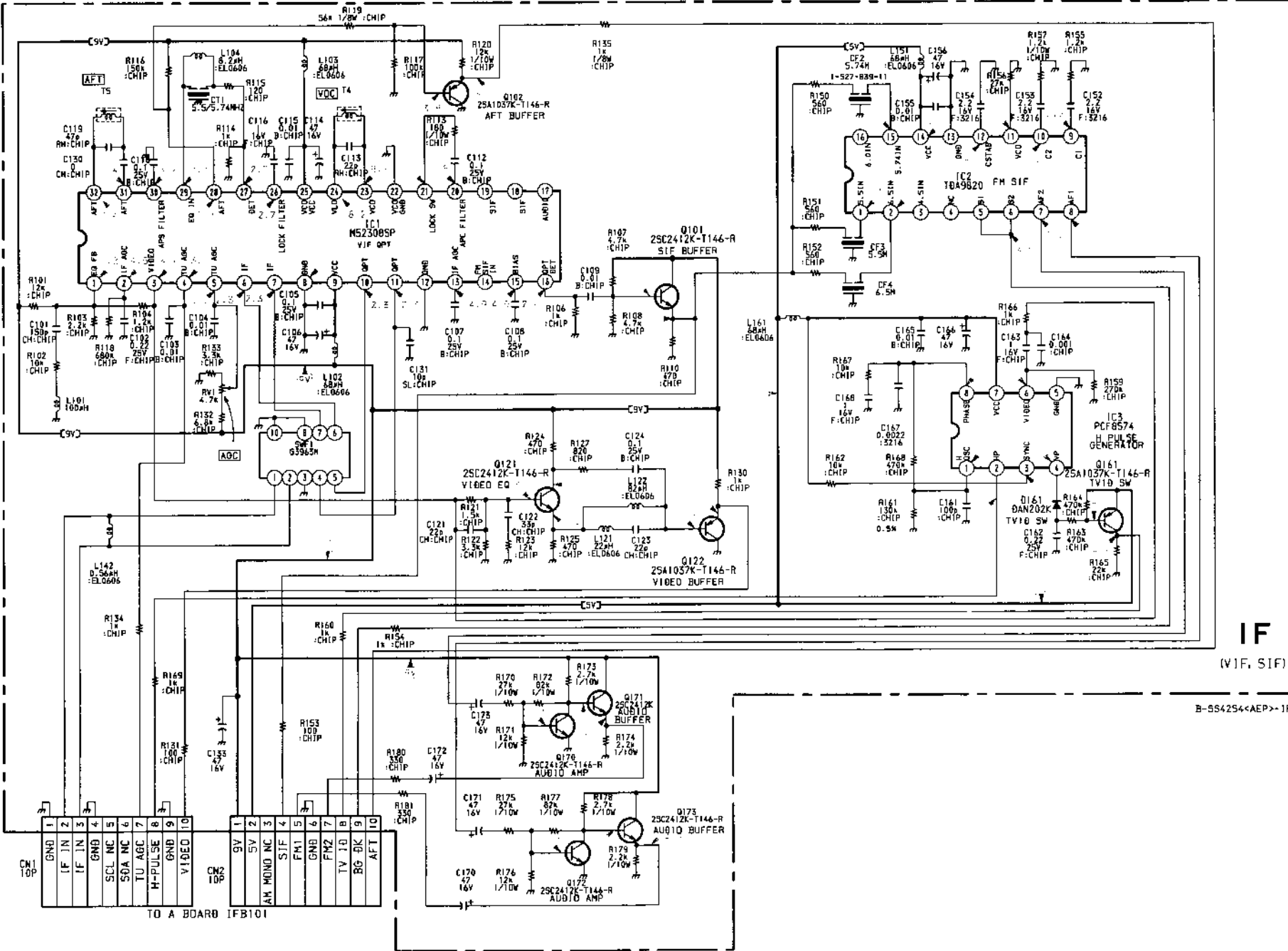

B-S34254(AEP)-1F.

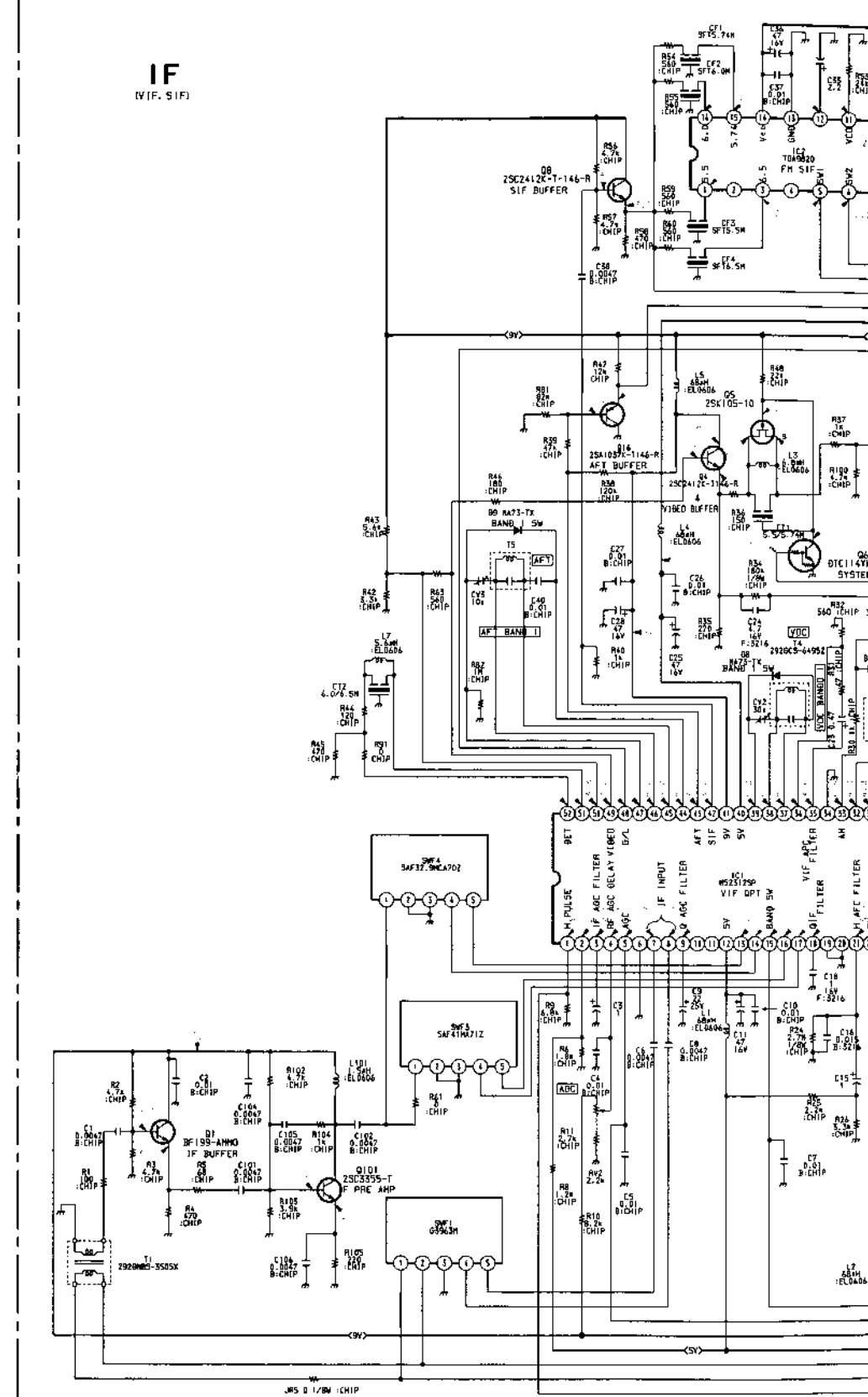

J5 1/2W CHIP

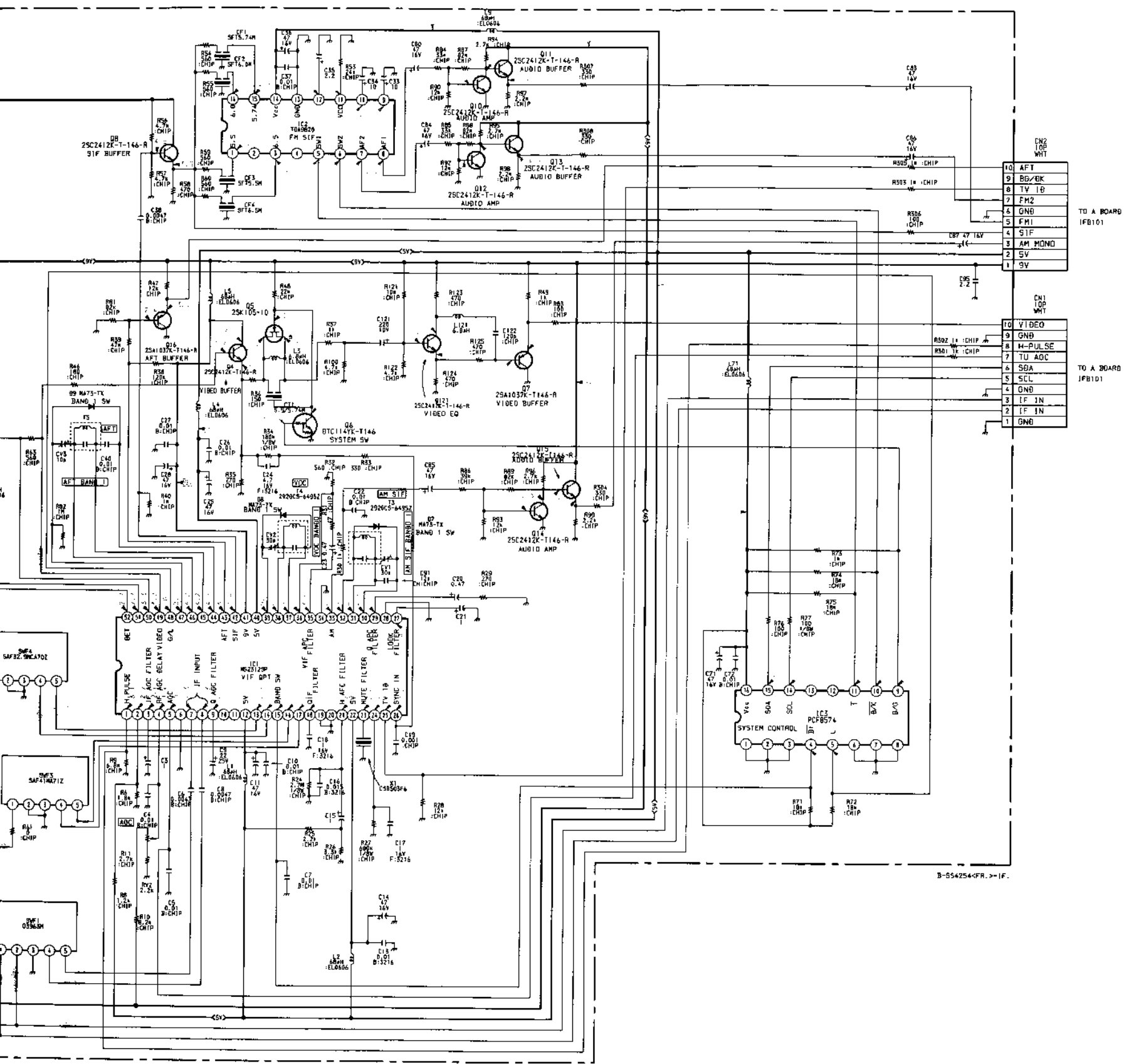

• IF BOARD IC2 TDA9820 (KV-S3411D/S3413E)

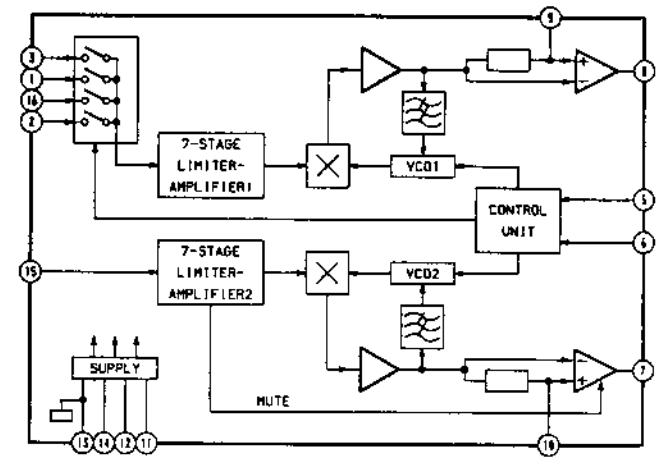

• IF BOARD IC3 BA7046 (KV-S3411D/S3413E)

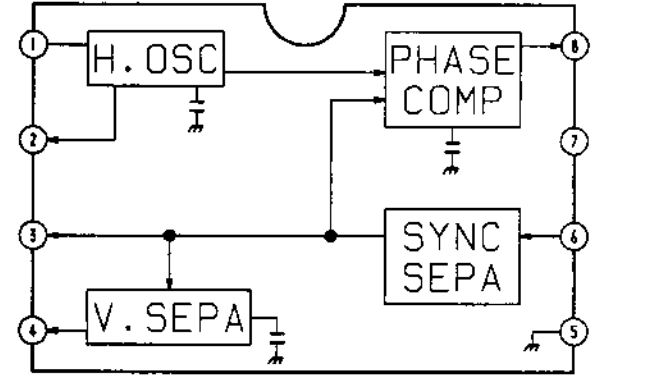

• IF BOARD IC3 PCF8574 (KV-S3411B)

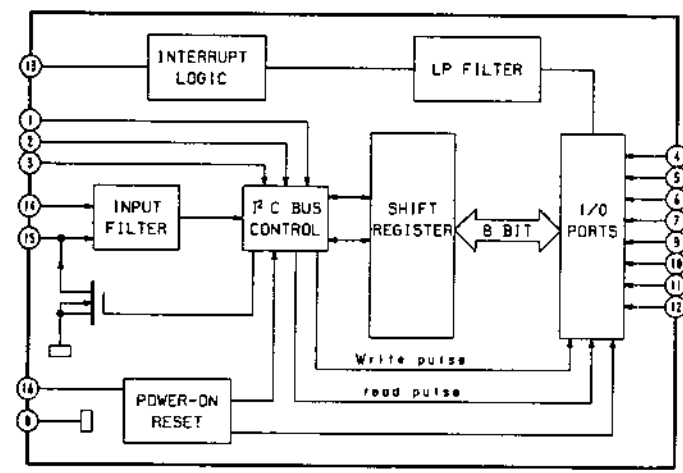

- IF BOARD - (KV-S3411D/S3413E)

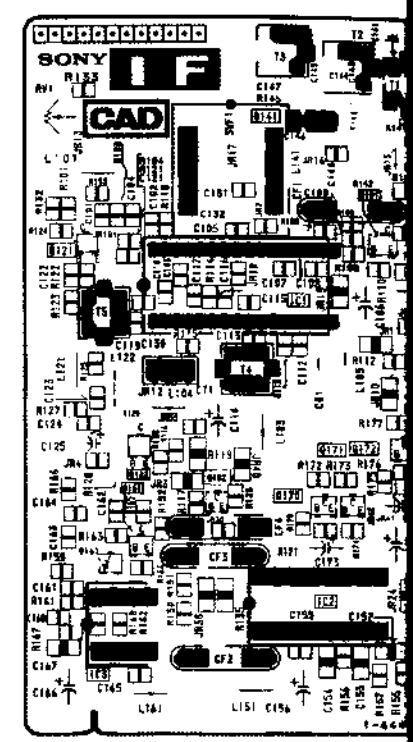

IF [VIF, SIF]

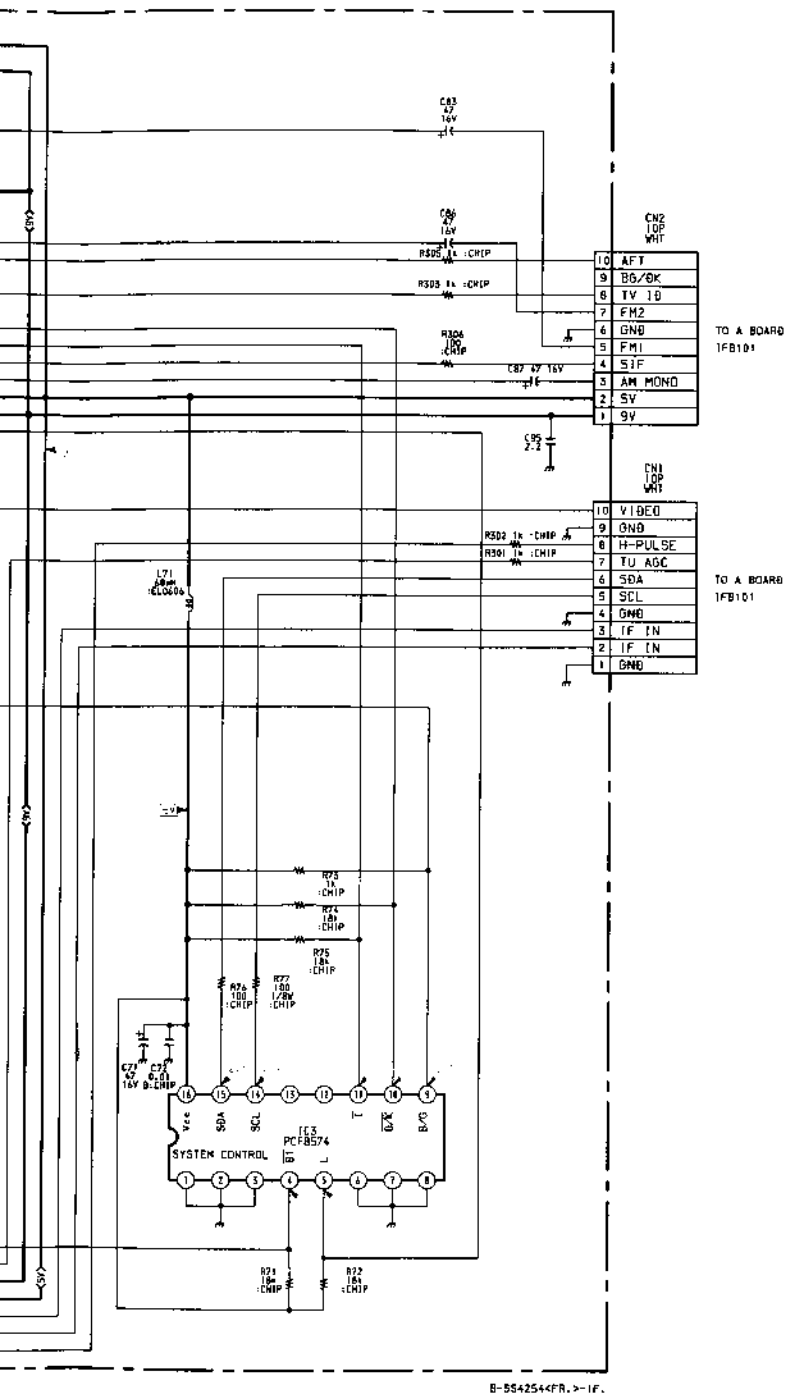

B-554254FR. >-IF.

• IF BOARD IC2 TDA9820 (KV-S3411D/S3413E)

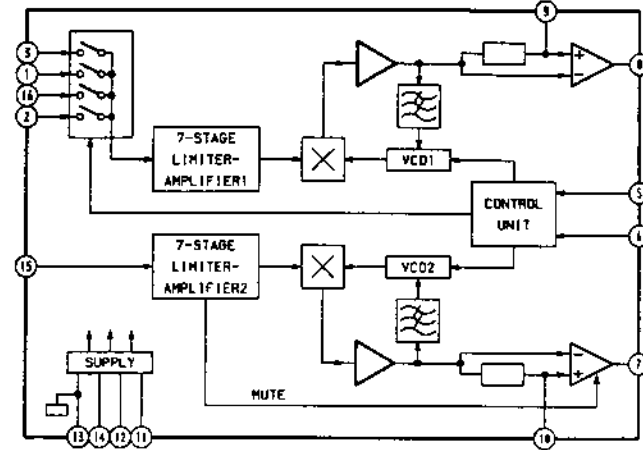

• IF BOARD IC3 BA7046 (KV-S3411D/S3413E)

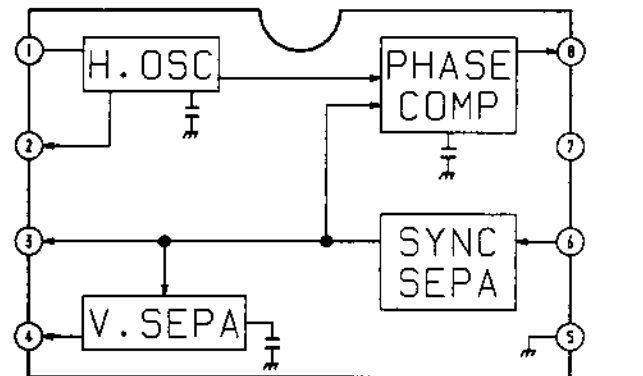

• IF BOARD IC3 PCF8574 (KV-S3411B)

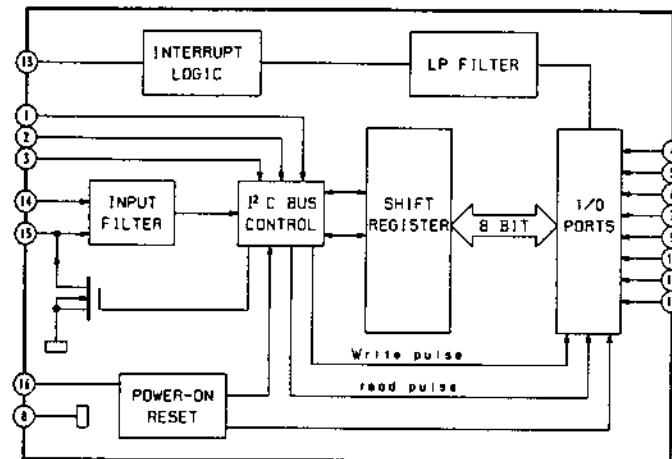

- IF BOARD - (KV-S3411D/S3413E only)

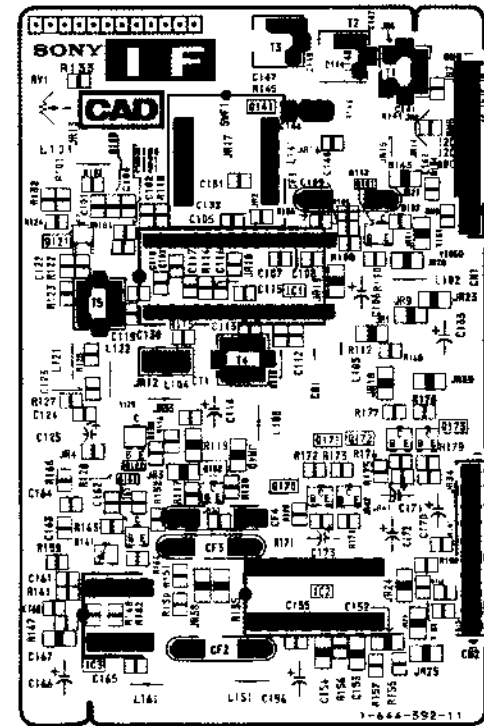

- IF BOARD - (KV-S3411B Only)

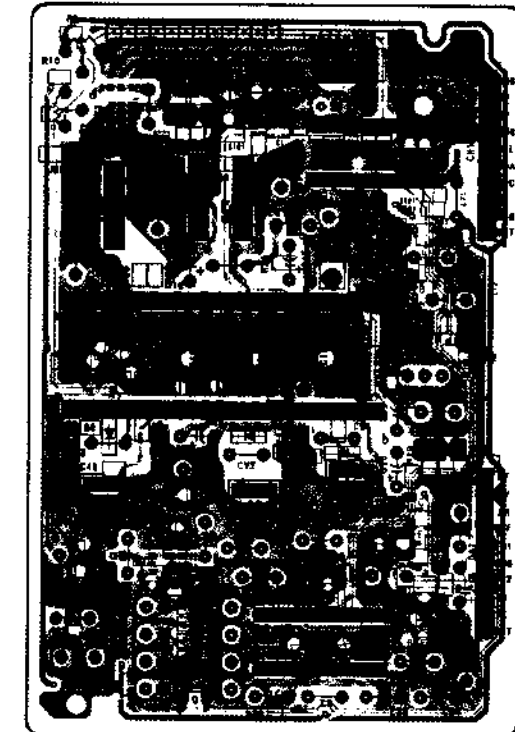

Note :

- : Pattern from the side which enables seeing.
- : Pattern of the rear side.

IFH395 (KV-S3412U only)

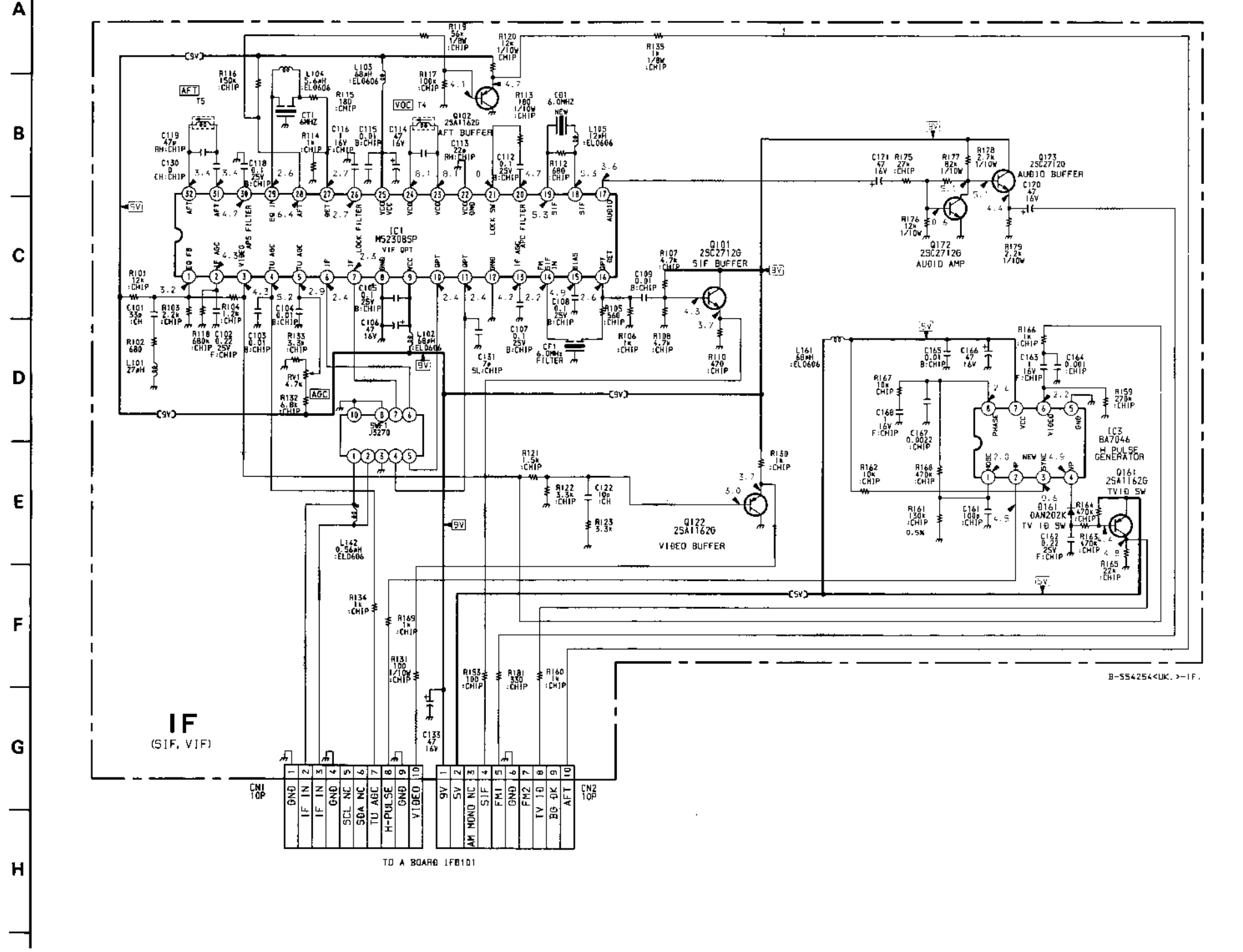

- IF BOARD - (KV-S3412U only)

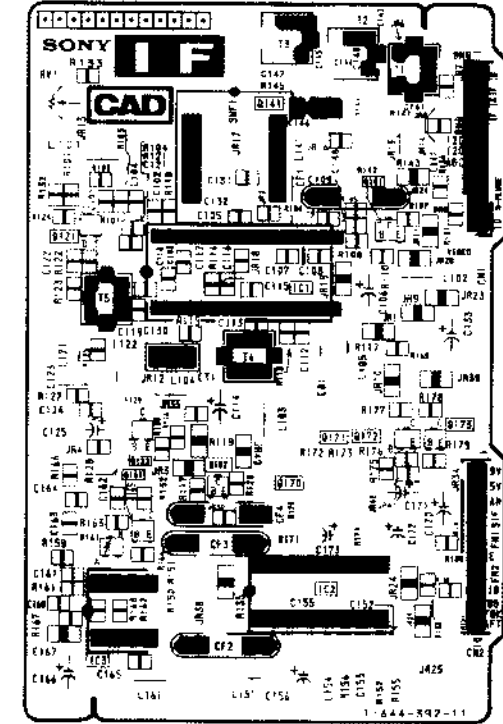

7 8 9 10

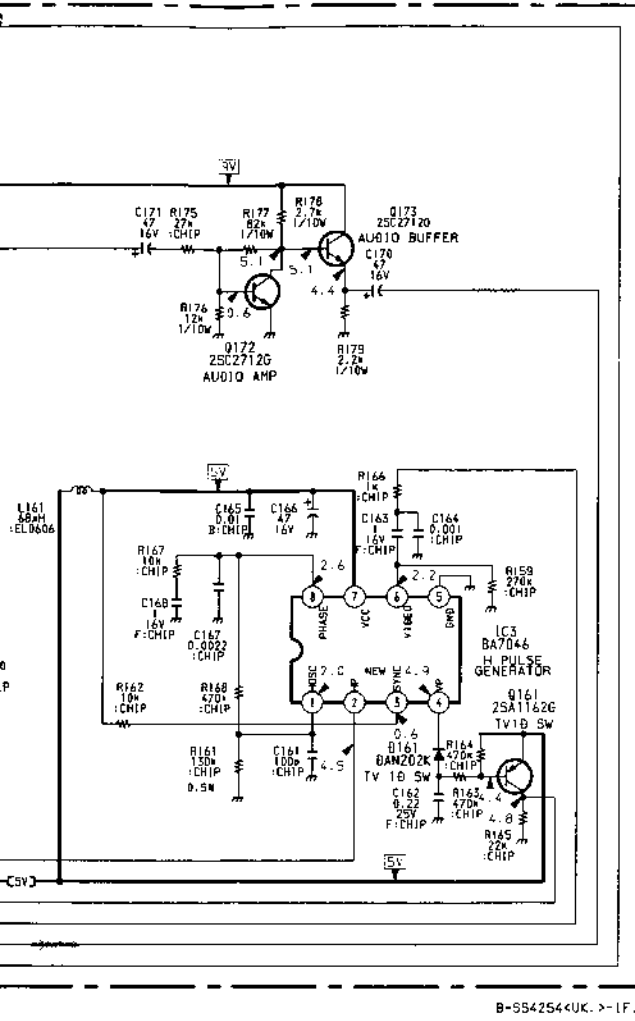

B-5S4254<UK> - IF.

- IF BOARD - (KV-S3412U only)

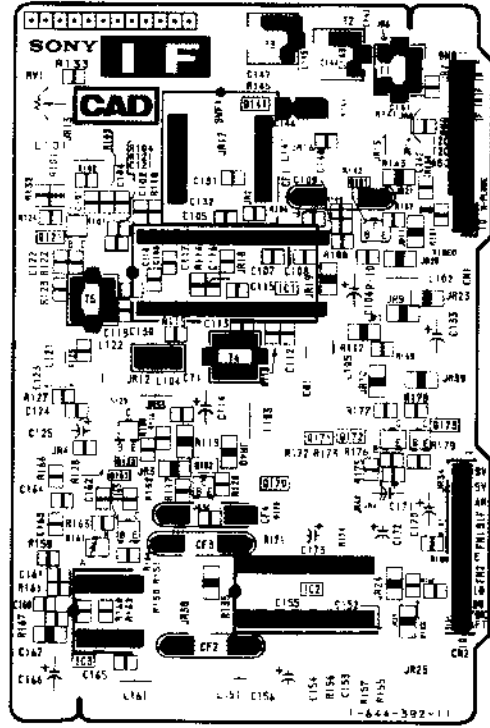

5-5. SCHEMATIC DIAGRAM OF TUNER
A BOARD TU101 UV916H

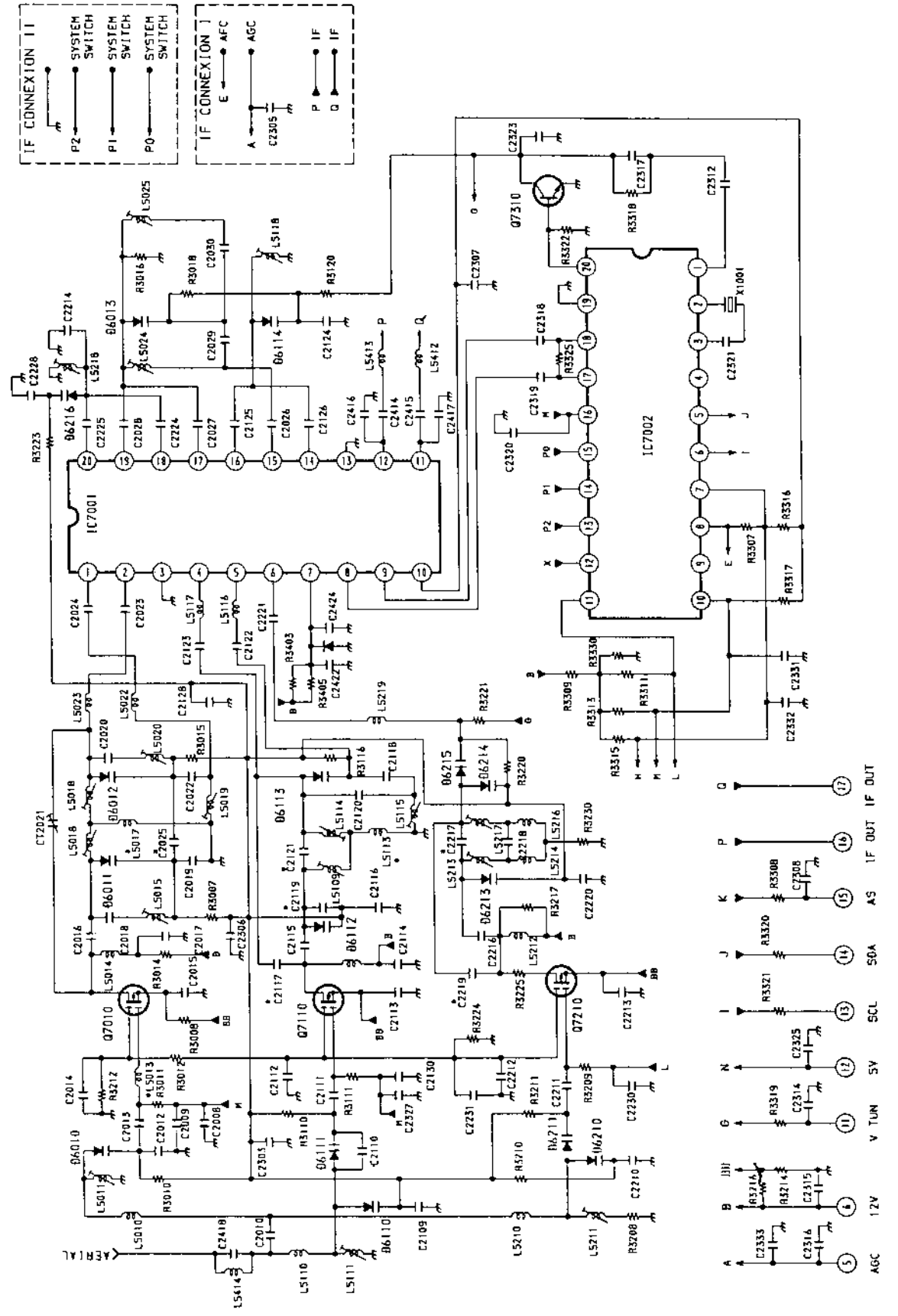

5-6. SEMICONDUCTORS

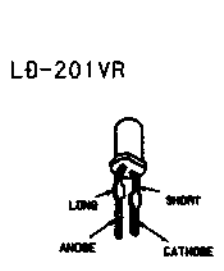
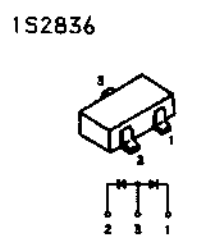
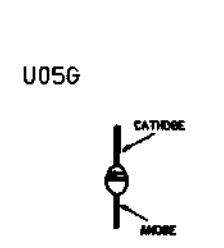
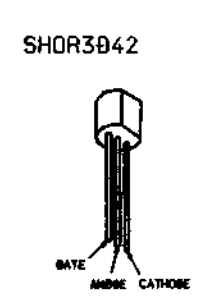
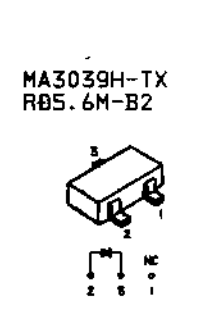
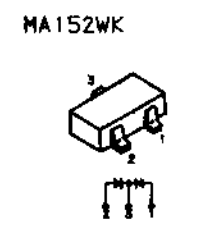
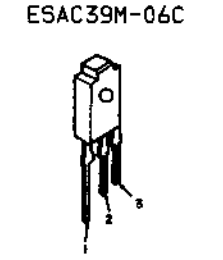
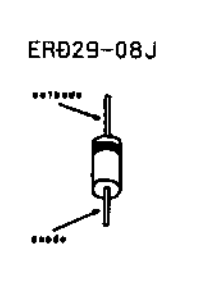
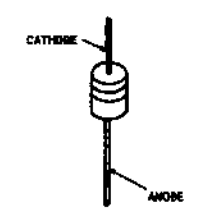
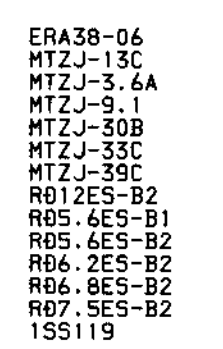
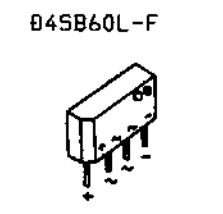
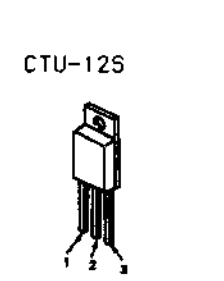
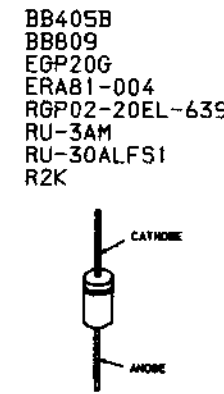
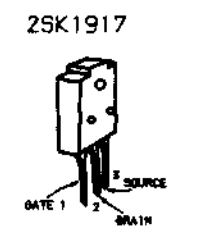
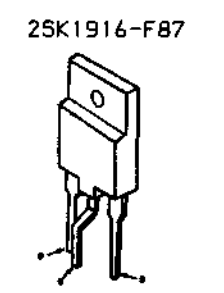
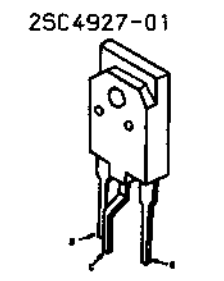
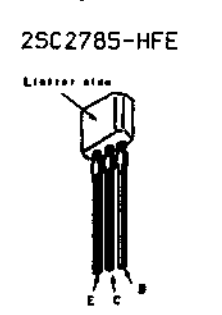
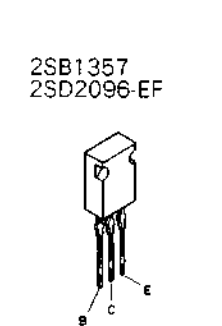
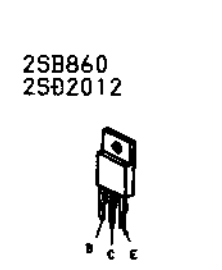
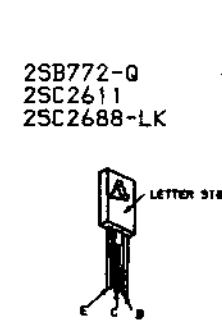
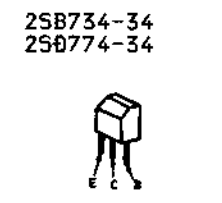
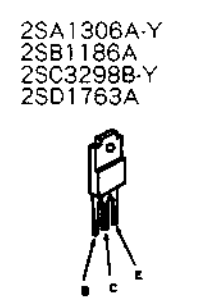
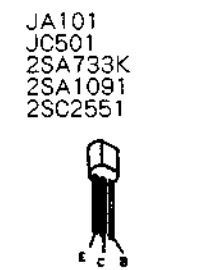
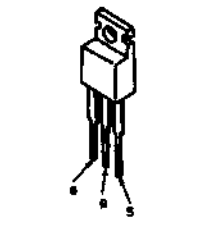
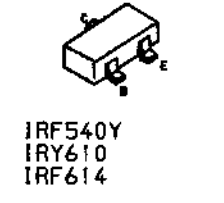
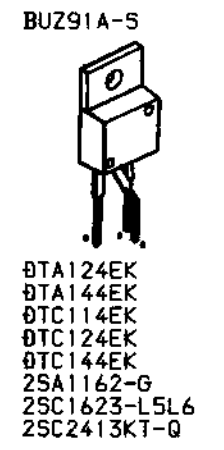
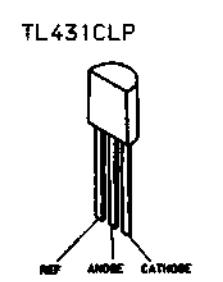
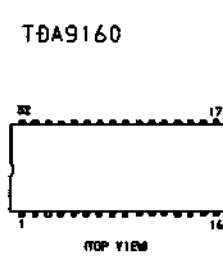
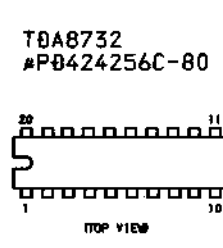
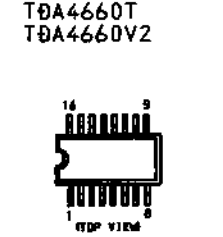
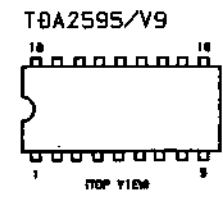
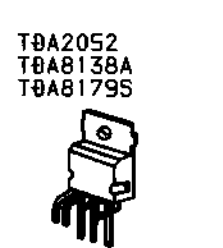
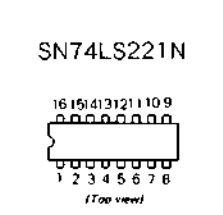
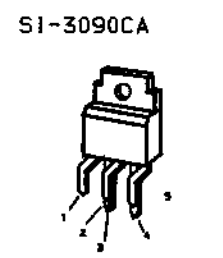
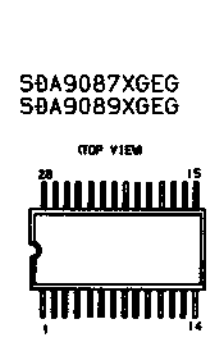
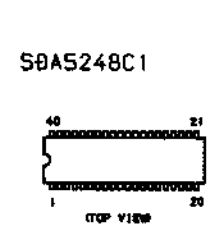
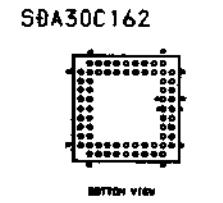
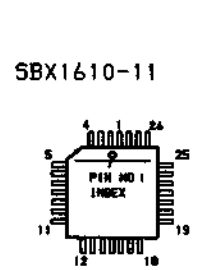
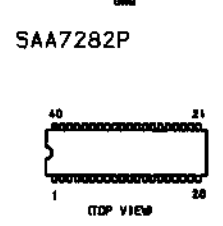
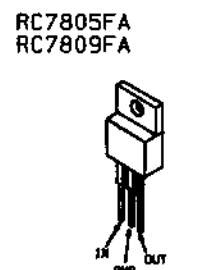
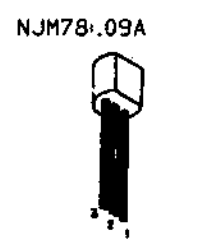
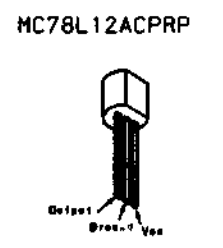
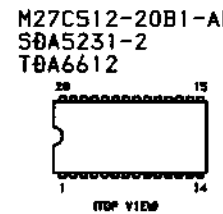
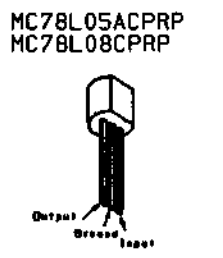
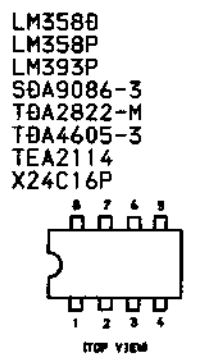
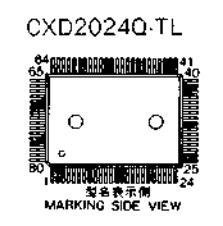
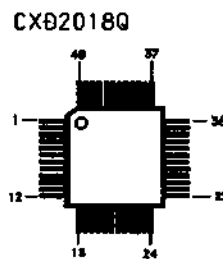
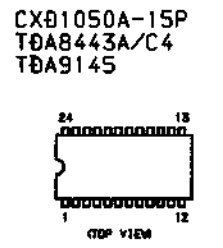
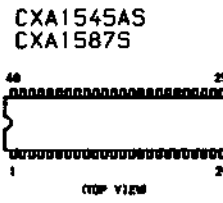
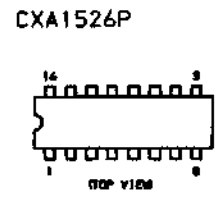

NOTE: Items with description are selected. The component number. Items marked with a service when or

6-1. CHAS ●: BV ■: BV

REF. NO.	PART
1	*1-6
2	*1-6
3	4-2
4	Δ 1-3
5	*A-1
6	Δ 4-4
7	Δ 1-3
	Δ 1-3
8	*A-1
9	*4-2
10	*A-1
11	*4-2
12	*A-1
13	Δ 1-3
14	*A-1
15	*A-1
	*A-1
	*A-1

SECTION 6
EXPLODED VIEWS

2SB734-34
2SB774-34



2SC4927-01



Ø4SB60L-F



MA152WK



1S2836

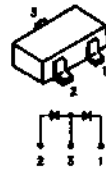

2SB772-0
2SC2611
2SC2688-LK



2SK1916-F87

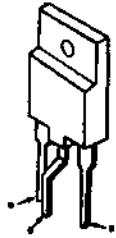

ERA38-06
MTZJ-13C
MTZJ-3.6A
MTZJ-9.1
MTZJ-30B
MTZJ-33C
MTZJ-39C
RØ12ES-B2
RØ5.6ES-B1
RØ5.6ES-B2
RØ6.2ES-B2
RØ6.8ES-B2
RØ7.5ES-B2
ISS119

MA3039H-TX
RØ5.6M-B2



LD-201VR

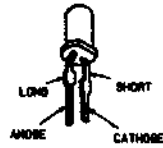

2SB860
2SD2012



2SK1917

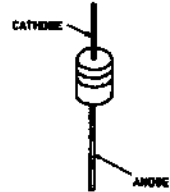
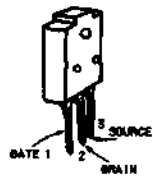

SHØR3Ø42



2SB1357
2SD2096-EF



BB405B
BB809
EGP20G
ERA81-004
RGPØ2-2ØEL-6394
RU-3AM
RU-3ØALFS1
R2K

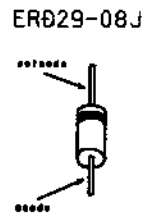

UØ5G

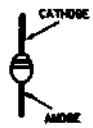

2SC2785-HFE

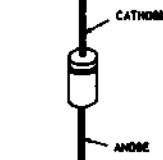
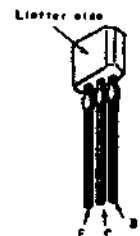

ESAC39M-Ø6C



ISS226

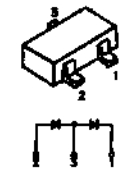

2SC3840K



CTU-125



NOTE:

- Items with no part number and no description are not stocked because they are seldom required for routine service.
- The construction parts of an assembled part are indicated with a collation number in the remark column.
- Items marked " * " are not stocked since they are seldom required for routine service. Some delay should be anticipated when ordering these items.

The components identified by shading and mark Δ are critical for safety. Replace only with part number specified.

Les composants identifiés par une trame et une marque Δ sont critiques pour la sécurité. Ne les remplacer que par une pièce portant le numéro spécifié.

6-1. CHASSIS

- : BVTP3 x 12 7-685-648-71
- : BVTP4 x 16 7-685-663-79

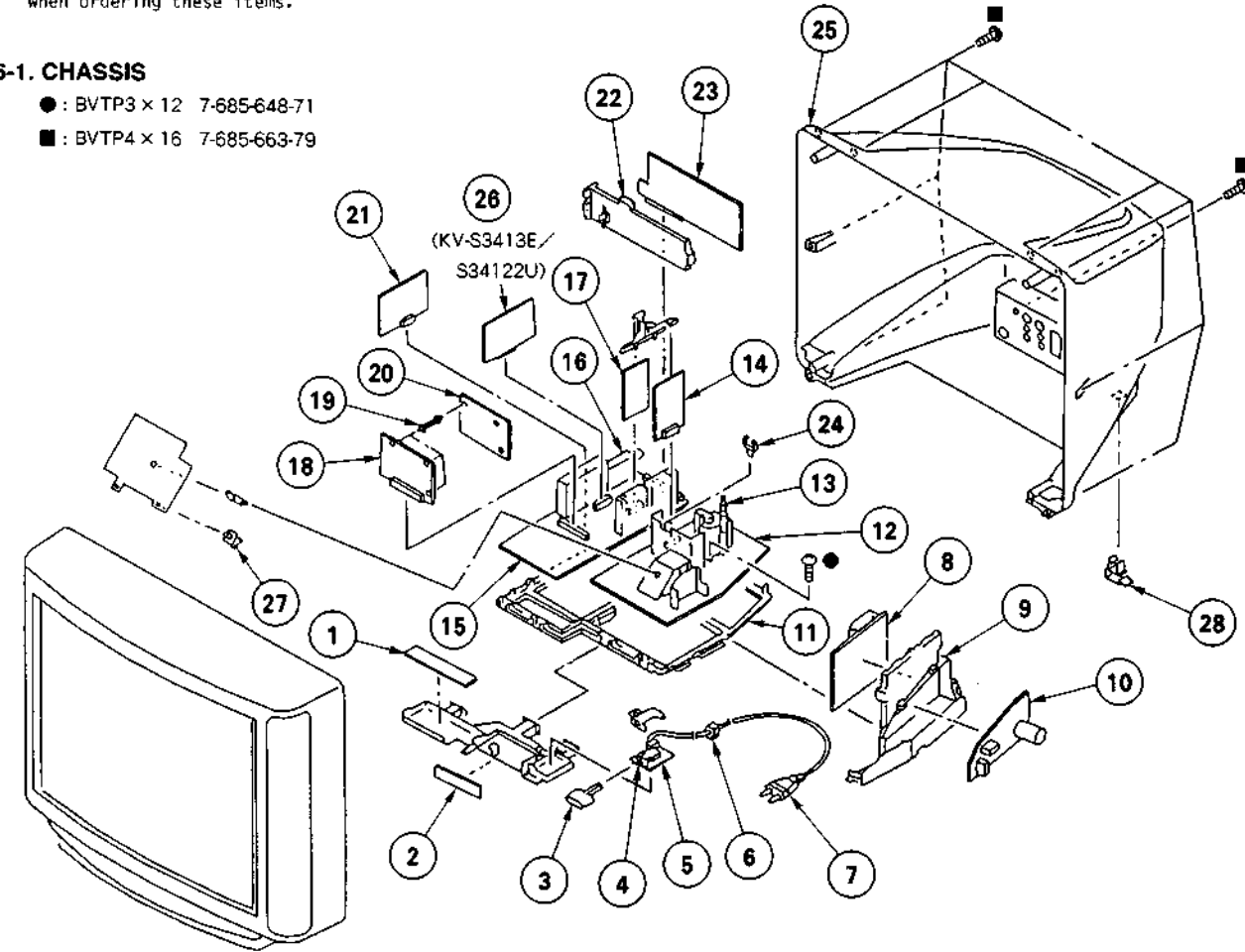

REF. NO.	PART NO.	DESCRIPTION	REMARK	REF. NO.	PART NO.	DESCRIPTION	REMARK
1	*1-643-004-21	H1 BOARD		16	Δ 1-693-185-11	TUNER (UV916H)	
2	*1-642-997-11	H2 BOARD				(KV-S3411A, S3411B, S3411D, S3413E)	
3	4-202-124-01	BUTTON, POWER		17	Δ 1-693-184-11	TUNER (U944C) (KV-S3412U)	
4	Δ 1-571-433-12	SWITCH, PUSH (AC POWER)		18	*A-1620-049-A	B BOARD, COMPLETE	
5	*A-1241-086-A	F1 BOARD, COMPLETE			*A-1635-001-A	M BOARD, COMPLETE	
6	Δ 4-389-201-04	HOLDER, AC CORD		19	*3-682-419-01	HOLDER, P.C.B	
7	Δ 1-590-501-11	CORD, POWER (WITH NOISE FILTER)		20	*A-1347-069-A	V BOARD, COMPLETE	
		(KV-S3411A, S3411B, S3411D, S3413E)		21	*A-1622-005-A	P BOARD, COMPLETE	
	Δ 1-590-762-11	CORD, POWER (WITH PLUG) (KV-S3412U)		22	*4-202-135-01	BRACKET, J	
8	*A-1640-098-A	D1 BOARD, COMPLETE		23	*A-1388-145-A	J BOARD, COMPLETE	
9	*4-202-140-01	BRACKET, F		24	*3-646-071-00	HOLDER, WIRE	
10	*A-1624-017-A	F2 BOARD, COMPLETE		25	4-039-608-01	COVER, REAR	
11	*4-202-141-01	BRACKET, MAIN		26	*A-1292-247-A	A1 BOARD, COMPLETE (KV-S3412U)	
12	*A-1642-095-A	D BOARD, COMPLETE			*A-1292-248-A	A1 BOARD, COMPLETE (KV-S3413E)	
13	Δ 1-453-126-11	TRANSFORMER ASSY, FLYBACK (NX-3000A3)		27	*4-313-732-00	CLIP, HINGE, CIRCUIT BOARD	
14	*A-1640-106-A	D2 BOARD, COMPLETE		28	Δ 4-038-615-01	HOLDER, AC CORD	
15	*A-1297-008-A	A BOARD, COMPLETE				(KV-S3411A, S3411D, S3413E)	
		*A-1297-007-A	A BOARD, COMPLETE (KV-S3411B)				
		*A-1297-012-A	A BOARD, COMPLETE (KV-S3412U)				

6-2. PICTURE TUBE

- : BVTP3 × 12 7-685-648-71
- : BVTP4 × 16 7-685-663-79

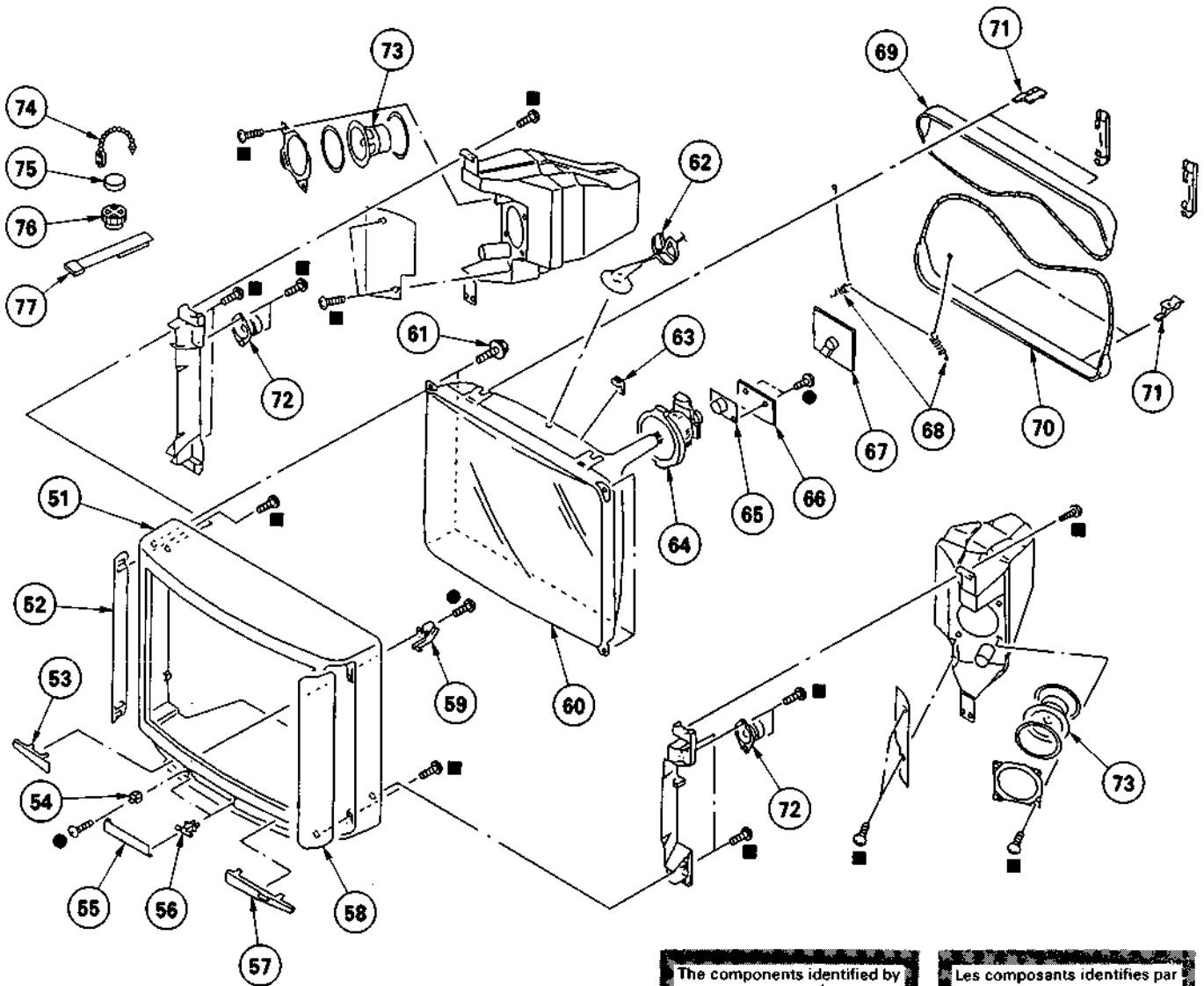

The components identified by shading and mark Δ are critical for safety. Replace only with part number specified.

Les composants identifiés par une trame et une marque Δ sont critiques pour la sécurité. Ne les remplacer que par une pièce portant le numéro spécifié.

REF. NO.	PART NO.	DESCRIPTION	REMARK	REF. NO.	PART NO.	DESCRIPTION	REMARK
51	X-4030-985-1	CABINET ASSY (WITH BEZEL ASSY)		64	Δ 1-451-393-11	DEFLECTION YOKE (Y346XA)	
52	X-4030-983-1	GRILLE (LEFT) ASSY, SPEAKER		65	Δ 1-452-616-13	NECK ASSY, PICTURE TUBE (NA323)	
53	4-202-127-01	PLATE, ORNAMENTAL		66	*A-1342-189-A	VK BOARD, COMPLETE	
	4-202-127-11	PLATE, ORNAMENTAL (KV-S3411A, S3411B, S3411D)		67	*A-1638-033-A	C BOARD, COMPLETE	
		(KV-S3411A, S3411B, S3411D)		68	4-369-318-00	SPRING, TENSION	
		(KV-S3412U, S3413E)		69	Δ 1-406-701-11	COIL, DEMAGNETIZATION	
54	4-036-881-01	LOCK ASSY, DOOR		70	Δ 1-406-702-11	COIL, DEMAGNETIZATION	
55	4-202-125-01	DOOR		71	4-033-744-01	CLIP	
56	3-703-035-11	SHAFT, LID		72	1-504-121-21	SPEAKER (SQUAWKER) (5CM)	
57	4-202-123-01	WINDOW, ORNAMENTAL		73	1-504-145-11	SPEAKER (12CM)	
58	X-4030-984-1	GRILLE (RIGHT) ASSY, SPEAKER		74	4-308-870-00	CLIP, LEAD WIRE	
59	X-4030-459-1	DAMPER ASSY		75	1-452-032-00	MAGNET, DISK; 10MM ϕ	
60	Δ 8-733-731-05	PICTURE TUBE (NB1KYA10X)		76	1-452-094-00	MAGNET, ROTATABLE DISK; 15MM ϕ	
61	4-036-188-01	SCREW (M), PT		77	X-4306-312-0	PERMALLOY ASSY, CONVERGENCE	
62	*3-704-372-01	HOLDER, HV CABLE					
63	3-704-495-01	SPACER, DY					

SECTION 7
ELECTRICAL PARTS LIST

F1 A1

NOTE:

The components identified by shading and mark Δ are critical for safety. Replace only with part number specified.

Les composants identifiés par une trame et une marque Δ sont critiques pour la sécurité. Ne les remplacer que par une pièce portant le numéro spécifié.

- Items marked " * " are not stocked since they are seldom required for routine service. Some delay should be anticipated when ordering these items.
- All variable and adjustable resistors have characteristic curve B, unless otherwise noted.

When indicating parts by reference number, please include the board name.

CAPACITORS
• MF : μ F, PF : μ F • COILS
• MMH : mH, UH : μ H

- RESISTORS
- All resistors are in ohms
 - F : nonflammable

REF. NO.	PART NO.	DESCRIPTION	REMARK	REF. NO.	PART NO.	DESCRIPTION	REMARK
*A-1241-086-A	F1 BOARD, COMPLETE	*****		C1120	1-163-193-00	CERAMIC CHIP 330PF	5% 50V
1-533-230-11	HOLDER, FUSE			C1121	1-163-113-00	CERAMIC CHIP 68PF	5% 50V
	<CONNECTOR>			C1122	1-163-081-00	CERAMIC CHIP 0.22MF	25V
CN0003A	*1-580-844-11 PIN, CONNECTOR (POWER)			C1123	1-106-228-00	MYLAR 0.22MF	10% 100V
CN0831A	*1-695-292-11 PIN, CONNECTOR (POWER)			C1124	1-124-477-11	ELECT 47MF	20% 16V
	<FUSE>			C1125	1-124-477-11	ELECT 47MF	20% 16V
F651	Δ 1-576-232-21 FUSE (H.B.C.) 5A/250V			C1126	1-163-077-00	CERAMIC CHIP 0.1MF	10% 25V
	<SWITCH>			C1127	1-163-038-00	CERAMIC CHIP 0.1MF	25V
S651	Δ 1-571-433-12 SWITCH, PUSH (AC POWER)			C1128	1-124-477-11	ELECT 47MF	20% 16V
*****				C1129	1-163-038-00	CERAMIC CHIP 0.1MF	25V
*A-1292-247-A	A1 BOARD, COMPLETE (KV-S3412U)	*****		C1130	1-163-205-00	CERAMIC CHIP 0.001MF	10% 50V
*A-1292-248-A	A1 BOARD, COMPLETE (KV-S3413E)	*****		C1131	1-163-059-00	CERAMIC CHIP 0.01MF	50V
	<FILTER>			C1132	1-163-038-00	CERAMIC CHIP 0.1MF	25V
BP1101	1-236-238-11 FILTER, BAND PASS (KV-S3412U)			C1133	1-124-907-11	ELECT 10MF	20% 50V
	1-239-047-11 FILTER, BAND PASS (KV-S3413E)			C1134	1-163-009-11	CERAMIC CHIP 0.001MF	10% 50V
CF1101	1-409-333-00 TRAP, CERAMIC (6.0MHZ) (KV-S3412U)			C1135	1-163-038-00	CERAMIC CHIP 0.1MF	25V
CF1102	1-404-134-00 TRAP, CERAMIC (5.5MHZ) (KV-S3413E)			C1136	1-163-117-00	CERAMIC CHIP 100PF	5% 50V
	<CAPACITOR>			C1137	1-163-038-00	CERAMIC CHIP 0.1MF	25V
C1101	1-126-101-11 ELECT 100MF 20% 16V			C1138	1-163-105-00	CERAMIC CHIP 33PF	5% 50V
C1102	1-126-101-11 ELECT 100MF 20% 16V			C1139	1-163-105-00	CERAMIC CHIP 33PF	5% 50V
C1103	1-163-038-00 CERAMIC CHIP 0.1MF 25V			C1140	1-163-181-00	CERAMIC CHIP 100PF	5% 50V
C1104	1-163-077-00 CERAMIC CHIP 0.1MF 10% 25V			C1141	1-163-205-00	CERAMIC CHIP 0.001MF	5% 50V
C1105	1-164-489-11 CERAMIC CHIP 0.22MF 10% 16V			C1142	1-163-019-00	CERAMIC CHIP 0.0068MF	50V
C1106	1-163-187-00 CERAMIC CHIP 180PF 5% 50V			C1143	1-163-003-11	CERAMIC CHIP 330PF	10% 50V
C1107	1-163-009-11 CERAMIC CHIP 0.001MF 10% 50V			C1144	1-163-121-00	CERAMIC CHIP 150PF	5% 50V
C1108	1-163-059-00 CERAMIC CHIP 0.01MF 50V			C1145	1-163-121-00	CERAMIC CHIP 150PF	5% 50V
C1109	1-163-033-00 CERAMIC CHIP 0.022MF 50V			C1146	1-163-038-00	CERAMIC CHIP 0.1MF	25V
C1110	1-164-336-11 CERAMIC CHIP 0.33MF 25V			C1147	1-124-477-11	ELECT 47MF	20% 16V
C1111	1-163-009-11 CERAMIC CHIP 0.001MF 10% 50V			C1148	1-164-161-11	CERAMIC CHIP 0.0022MF	10% 50V
C1112	1-164-161-11 CERAMIC CHIP 0.0022MF 10% 50V			C1149	1-124-477-11	ELECT 47MF	20% 16V
C1113	1-124-477-11 ELECT 47MF 20% 16V			C1150	1-163-038-00	CERAMIC CHIP 0.1MF	25V
C1114	1-163-038-00 CERAMIC CHIP 0.1MF 25V			C1151	1-163-038-00	CERAMIC CHIP 0.1MF	25V
C1115	1-124-477-11 ELECT 47MF 20% 16V			C1152	1-124-477-11	ELECT 47MF	20% 16V
C1116	1-106-228-00 MYLAR 0.22MF 10% 100V			C1153	1-163-087-00	CERAMIC CHIP 4PF	0.25PF 50V
C1117	1-163-081-00 CERAMIC CHIP 0.22MF 25V			C1154	1-163-038-00	CERAMIC CHIP 0.1MF	25V
C1118	1-163-113-00 CERAMIC CHIP 68PF 5% 50V			C1155	1-124-477-11	ELECT 47MF	20% 16V
C1119	1-163-193-00 CERAMIC CHIP 330PF 5% 50V			C1156	1-163-009-11	CERAMIC CHIP 0.001MF	10% 50V
				C1157	1-163-009-11	CERAMIC CHIP 0.001MF	10% 50V
				C1158	1-163-038-00	CERAMIC CHIP 0.1MF	25V
				C1159	1-163-243-11	CERAMIC CHIP 47PF	5% 50V
							(KV-S3412U)
						<CONNECTOR>	
				CN0201	1-695-300-11	CONNECTOR, BOARD TO BOARD 20P	
						<DIODE>	
				D1101	8-719-104-34	DIODE 1S2836	
				D1102	8-719-027-70	DIODE 1SV217-TPH3	
				D1103	8-719-820-71	DIODE 1SV214	

A1 A

REF. NO.	PART NO.	DESCRIPTION	REMARK	REF. NO.	PART NO.	DESCRIPTION	REMARK
<FERRITE BEAD>				R1124	1-216-089-00	METAL GLAZE 47K 5%	1/10W
FB1101	1-410-396-41	FERRITE BEAD INDUCTOR		R1125	1-216-097-00	METAL GLAZE 100K 5%	1/10W
FB1102	1-410-396-41	FERRITE BEAD INDUCTOR		R1126	1-216-218-00	METAL GLAZE 6.8K 5%	1/8W
FB1103	1-410-396-41	FERRITE BEAD INDUCTOR		R1127	1-216-097-00	METAL GLAZE 100K 5%	1/10W
FB1104	1-410-396-41	FERRITE BEAD INDUCTOR		R1128	1-216-089-00	METAL GLAZE 47K 5%	1/10W
FB1105	1-410-396-41	FERRITE BEAD INDUCTOR		R1129	1-216-089-00	METAL GLAZE 47K 5%	1/10W
FB1107	1-410-396-41	FERRITE BEAD INDUCTOR		R1130	1-216-246-00	METAL GLAZE 100K 5%	1/8W
<IC>				R1131	1-216-218-00	METAL GLAZE 6.8K 5%	1/8W
IC1101	8-759-511-88	IC TDA8732		R1132	1-216-097-00	METAL GLAZE 100K 5%	1/10W
IC1102	8-759-073-17	IC SAA7282P		R1133	1-216-089-00	METAL GLAZE 47K 5%	1/10W
<COIL>				R1134	1-216-212-00	METAL GLAZE 3.9K 5%	1/8W
L1101	1-408-405-00	INDUCTOR 4.7UH		R1135	1-216-081-00	METAL GLAZE 22K 5%	1/10W
L1102	1-408-405-00	INDUCTOR 4.7UH		R1136	1-216-081-00	METAL GLAZE 22K 5%	1/10W
L1103	1-410-119-11	INDUCTOR 1MH		R1137	1-216-095-00	METAL GLAZE 82K 5%	1/10W
L1104	1-410-119-11	INDUCTOR 1MH		R1138	1-216-097-00	METAL GLAZE 100K 5%	1/10W
L1105	1-408-411-00	INDUCTOR 15UH (KV-S3412U)		R1139	1-216-005-00	METAL GLAZE 15 5%	1/10W
<TRANSISTOR>				R1140	1-216-061-00	METAL GLAZE 3.3K 5%	1/10W
Q1101	8-729-901-81	TRANSISTOR 2SC2412K-T-146-R		R1141	1-216-061-00	METAL GLAZE 3.3K 5%	1/10W
Q1102	8-729-901-81	TRANSISTOR 2SC2412K-T-146-R		R1142	1-216-033-00	METAL GLAZE 220 5%	1/10W
Q1103	8-729-901-81	TRANSISTOR 2SC2412K-T-146-R		R1143	1-216-049-00	METAL GLAZE 1K 5%	1/10W
Q1104	8-729-901-81	TRANSISTOR 2SC2412K-T-146-R		R1144	1-216-049-00	METAL GLAZE 1K 5%	1/10W
Q1105	8-729-901-81	TRANSISTOR 2SC2412K-T-146-R		R1145	1-216-001-00	METAL GLAZE 10 5%	1/10W
Q1106	8-729-901-81	TRANSISTOR 2SC2412K-T-146-R		R1146	1-216-049-00	METAL GLAZE 1K 5%	1/10W
Q1107	8-729-901-81	TRANSISTOR 2SC2412K-T-146-R		R1147	1-216-045-00	METAL GLAZE 680 5%	1/10W
Q1108	8-729-901-81	TRANSISTOR 2SC2412K-T-146-R		R1148	1-216-049-00	METAL GLAZE 1K 5%	1/10W
<RESISTOR>				R1149	1-216-001-00	METAL GLAZE 10 5%	1/10W
JR1101	1-216-296-00	METAL GLAZE 0 5%	1/8W (KV-S3413E)	R1150	1-216-045-00	METAL GLAZE 680 5%	1/10W
JR1102	1-216-296-00	METAL GLAZE 0 5%	1/8W	R1151	1-216-049-00	METAL GLAZE 1K 5%	1/10W
JR1103	1-216-296-00	METAL GLAZE 0 5%	1/8W	R1152	1-216-049-00	METAL GLAZE 1K 5%	1/10W
JR1104	1-216-295-00	METAL GLAZE 0 5%	1/10W	R1153	1-216-049-00	METAL GLAZE 1K 5%	1/10W
R1101	1-216-188-00	METAL GLAZE 390 5%	1/8W	R1154	1-216-041-00	METAL GLAZE 470 5%	1/10W
R1102	1-216-049-00	METAL GLAZE 1K 5%	1/10W	<CRYSTAL>			
R1103	1-216-198-00	METAL GLAZE 1K 5%	1/8W	X1101	1-579-689-21	VIBRATOR, CRYSTAL	
R1104	1-216-041-00	METAL GLAZE 470 5%	1/10W	X1102	1-579-283-11	VIBRATOR, CRYSTAL (KV-S3412U)	
R1105	1-216-005-00	METAL GLAZE 15 5%	1/10W		1-579-282-21	VIBRATOR, CRYSTAL (KV-S3413E)	
R1106	1-216-036-00	METAL GLAZE 300 5%	1/10W	*****			
R1107	1-216-042-00	METAL GLAZE 510 5%	1/10W	*A-1297-008-A	A BOARD, COMPLETE		
R1108	1-216-063-00	METAL GLAZE 3.9K 5%	1/10W		*****		
R1109	1-216-202-00	METAL GLAZE 1.5K 5%	1/8W		(KV-S3411A, S3411D, S3413E)		
R1110	1-216-196-00	METAL GLAZE 820 5%	1/8W	*A-1297-007-A	A BOARD, COMPLETE (KV-S3411B)		
R1111	1-216-041-00	METAL GLAZE 470 5%	1/10W		*****		
R1112	1-216-051-00	METAL GLAZE 1.2K 5%	1/10W	*A-1297-012-A	A BOARD, COMPLETE (KV-S3412U)		
R1113	1-216-001-00	METAL GLAZE 10 5%	1/10W		*****		
R1114	1-216-105-00	METAL GLAZE 220K 5%	1/10W		4-200-001-01 HOLDER, IC		
R1115	1-216-121-00	METAL GLAZE 1K 5%	1/10W		4-201-023-01 SPACER, INSULATING		
R1116	1-216-049-00	METAL GLAZE 1K 5%	1/10W		4-812-134-00 RIVET NYLON, 3.5		
R1117	1-216-097-00	METAL GLAZE 100K 5%	1/10W	<CAPACITOR>			
R1118	1-216-097-00	METAL GLAZE 100K 5%	1/10W	C071	1-124-126-00	ELECT 47MF	20% 10V
R1119	1-216-073-00	METAL GLAZE 10K 5%	1/10W	C072	1-124-120-11	ELECT 220MF	20% 16V
R1120	1-216-232-00	METAL GLAZE 27K 5%	1/8W	C074	1-163-001-11	CERAMIC CHIP 220PF	10% 50V
R1121	1-216-081-00	METAL GLAZE 22K 5%	1/10W	C102	1-126-103-11	ELECT 470MF	20% 16V
R1122	1-216-158-00	METAL GLAZE 22 5%	1/8W	C103	1-163-031-11	CERAMIC CHIP 0.01MF	50V
R1123	1-216-158-00	METAL GLAZE 22 5%	1/8W	C104	1-124-910-11	ELECT 47MF	20% 50V
				C105	1-124-916-11	ELECT 22MF	20% 50V
				C106	1-124-927-11	ELECT 4.7MF	20% 50V
							(KV-S3411A, S3411D, S3412U, S3413E)
				C106	1-124-907-11	ELECT 10MF	20% 50V
							(KV-S3411B)
				C110	1-124-478-11	ELECT 100MF	20% 25V

A

REF. NO.	PART NO.	DESCRIPTION	REMARK	REF. NO.	PART NO.	DESCRIPTION	REMARK
C120	1-163-031-11	CERAMIC CHIP 0.01MF	50V	C318	1-163-103-00	CERAMIC CHIP 27PF	5% 50V
C201	1-130-489-00	FILM 0.033MF	5% 50V	C319	1-163-038-00	CERAMIC CHIP 0.1MF	25V
C202	1-130-489-00	FILM 0.033MF	5% 50V	C320	1-124-910-11	ELECT 47MF	20% 50V
C203	1-164-005-11	CERAMIC CHIP 0.47MF	25V	C321	1-163-038-00	CERAMIC CHIP 0.1MF	25V
C204	1-164-005-11	CERAMIC CHIP 0.47MF	25V	C322	1-124-916-11	ELECT 22MF	20% 50V
C205	1-124-907-11	ELECT 10MF	20% 50V	C323	1-163-135-00	CERAMIC CHIP 560PF	5% 50V
C206	1-164-161-11	CERAMIC CHIP 0.0022MF	10% 50V	C324	1-124-910-11	ELECT 47MF	20% 50V
C207	1-137-613-11	FILM 0.0018MF	2% 100V	C325	1-163-111-00	CERAMIC CHIP 56PF	5% 50V
C208	1-164-005-11	CERAMIC CHIP 0.47MF	25V	C341	1-163-077-00	CERAMIC CHIP 0.1MF	10% 25V
C209	1-164-005-11	CERAMIC CHIP 0.47MF	25V	C342	1-163-077-00	CERAMIC CHIP 0.1MF	10% 25V
C210	1-164-005-11	CERAMIC CHIP 0.47MF	25V	C343	1-164-004-11	CERAMIC CHIP 0.1MF	10% 25V
C213	1-163-023-00	CERAMIC CHIP 0.015MF	10% 50V	C344	1-162-638-11	CERAMIC CHIP 1MF	16V
C214	1-163-023-00	CERAMIC CHIP 0.015MF	10% 50V	C345	1-164-346-11	CERAMIC CHIP 1MF	16V
C215	1-163-809-11	CERAMIC CHIP 0.047MF	10% 25V	C347	1-162-638-11	CERAMIC CHIP 1MF	16V
C216	1-163-809-11	CERAMIC CHIP 0.047MF	10% 25V	C348	1-164-346-11	CERAMIC CHIP 1MF	16V
C217	1-124-925-11	ELECT 2.2MF	20% 50V	C349	1-164-346-11	CERAMIC CHIP 1MF	16V
C218	1-124-925-11	ELECT 2.2MF	20% 50V	C350	1-124-907-11	ELECT 10MF	20% 50V
C219	1-163-011-11	CERAMIC CHIP 0.0015MF	10% 50V	C351	1-124-916-11	ELECT 22MF	20% 50V
C220	1-163-011-11	CERAMIC CHIP 0.0015MF	10% 50V	C353	1-164-346-11	CERAMIC CHIP 1MF	16V
C221	1-124-925-11	ELECT 2.2MF	20% 50V	C354	1-164-346-11	CERAMIC CHIP 1MF	16V
C222	1-124-925-11	ELECT 2.2MF	20% 50V	C355	1-162-638-11	CERAMIC CHIP 1MF	16V
C223	1-136-177-00	FILM 1MF	5% 50V	C356	1-164-489-11	CERAMIC CHIP 0.22MF	10% 16V
C224	1-136-177-00	FILM 1MF	5% 50V	C357	1-164-299-11	CERAMIC CHIP 0.22MF	10% 25V
C225	1-164-182-11	CERAMIC CHIP 0.0033MF	10% 50V	C358	1-164-299-11	CERAMIC CHIP 0.22MF	10% 25V
C226	1-163-007-11	CERAMIC CHIP 680PF	10% 50V	C359	1-124-907-11	ELECT 10MF	20% 50V
C227	1-124-907-11	ELECT 10MF	20% 50V	C361	1-163-101-00	CERAMIC CHIP 22PF	5% 50V
C228	1-124-907-11	ELECT 10MF	20% 50V	C362	1-130-772-00	FILM 0.22MF	5% 63V
C229	1-124-478-11	ELECT 100MF	20% 25V	C363	1-124-907-11	ELECT 10MF	20% 50V
C230	1-124-478-11	ELECT 100MF	20% 25V	C365	1-124-120-11	ELECT 220MF	20% 16V
C231	1-164-346-11	CERAMIC CHIP 1MF	16V	C366	1-124-903-11	ELECT 1MF	20% 50V
C232	1-163-009-11	CERAMIC CHIP 0.001MF	10% 50V	C401	1-164-005-11	CERAMIC CHIP 0.47MF	16V
C233	1-163-009-11	CERAMIC CHIP 0.001MF	10% 50V	C402	1-124-917-11	ELECT 33MF	20% 50V
C234	1-164-161-11	CERAMIC CHIP 0.0022MF	10% 50V	C403	1-162-637-11	CERAMIC CHIP 0.47MF	16V
C235	1-130-772-00	FILM 0.22MF	5% 63V	C411	1-164-005-11	CERAMIC CHIP 0.47MF	25V
C236	1-124-618-11	ELECT 2200MF	20% 35V	C412	1-164-005-11	CERAMIC CHIP 0.47MF	25V
C237	1-124-618-11	ELECT 2200MF	20% 35V	C421	1-124-910-11	ELECT 47MF	20% 50V
C238	1-164-161-11	CERAMIC CHIP 0.0022MF	10% 50V	C422	1-124-910-11	ELECT 47MF	20% 50V
C239	1-130-772-00	FILM 0.22MF	5% 63V	C423	1-101-004-00	CERAMIC 0.01MF	50V
C240	1-124-916-11	ELECT 22MF	20% 50V	C424	1-163-129-00	CERAMIC CHIP 330PF	5% 50V
C241	1-124-916-11	ELECT 22MF	20% 50V	C425	1-163-129-00	CERAMIC CHIP 330PF	5% 50V
C242	1-124-903-11	ELECT 1MF	20% 50V	C426	1-124-910-11	ELECT 47MF	20% 50V
C244	1-164-232-11	CERAMIC CHIP 0.01MF	10% 50V	C427	1-164-346-11	CERAMIC CHIP 1MF	16V
C248	1-163-185-00	CERAMIC CHIP 150PF	5% 50V	C428	1-164-346-11	CERAMIC CHIP 1MF	16V
C249	1-163-129-00	CERAMIC CHIP 330PF	5% 50V	C429	1-124-119-00	ELECT 330MF	20% 16V
C251	1-126-320-11	ELECT 10MF	20% 16V	C574	1-163-117-00	CERAMIC CHIP 100PF	5% 50V
C301	1-163-038-00	CERAMIC CHIP 0.1MF	25V	C581	1-163-031-11	CERAMIC CHIP 0.01MF	50V
C302	1-163-038-00	CERAMIC CHIP 0.1MF	25V	C582	1-124-916-11	ELECT 22MF	20% 50V
C303	1-164-337-11	CERAMIC CHIP 2.2MF	16V	C583	1-163-129-00	CERAMIC CHIP 330PF	5% 50V
C303A	1-124-903-11	ELECT 1MF	20% 50V	C586	1-163-063-00	CERAMIC CHIP 0.022MF	10% 50V
C304	1-164-004-11	CERAMIC CHIP 0.1MF	10% 25V	C587	1-124-903-11	ELECT 1MF	20% 50V
C305	1-163-097-00	CERAMIC CHIP 15PF	5% 50V	C588	1-164-346-11	CERAMIC CHIP 1MF	16V
C306	1-163-097-00	CERAMIC CHIP 15PF	5% 50V	C589	1-126-103-11	ELECT 470MF	20% 16V
C307	1-163-017-00	CERAMIC CHIP 0.0047MF	10% 50V	C590	1-124-916-11	ELECT 22MF	20% 50V
C308	1-163-809-11	CERAMIC CHIP 0.047MF	10% 25V	C591	1-124-925-11	ELECT 2.2MF	20% 50V
C309	1-164-004-11	CERAMIC CHIP 0.1MF	10% 25V	C592	1-163-017-00	CERAMIC CHIP 0.0047MF	10% 50V
C310	1-163-038-00	CERAMIC CHIP 0.1MF	25V	C593	1-164-182-11	CERAMIC CHIP 0.0033MF	10% 50V
C311	1-163-038-00	CERAMIC CHIP 0.1MF	25V	C595	1-163-109-00	CERAMIC CHIP 47PF	5% 50V
C312	1-124-910-11	ELECT 47MF	20% 50V	C599	1-164-232-11	CERAMIC CHIP 0.01MF	10% 50V
C313	1-163-077-00	CERAMIC CHIP 0.1MF	50V	C681	1-124-478-11	ELECT 100MF	20% 25V
C314	1-163-038-00	CERAMIC CHIP 0.1MF	25V	C682	1-126-101-11	ELECT 100MF	20% 16V
C315	1-124-910-11	ELECT 47MF	20% 50V	C683	1-124-478-11	ELECT 100MF	20% 25V
C316	1-163-077-00	CERAMIC CHIP 0.1MF	50V	C684	1-124-478-11	ELECT 100MF	20% 25V
C317	1-163-103-00	CERAMIC CHIP 27PF	5% 50V	C685	1-124-478-11	ELECT 100MF	20% 25V

(KV-S341IB)

The components identified by shading and mark Δ are critical for safety. Replace only with part number specified.

Les composants identifiés par une trame et une marque Δ sont critiques pour la sécurité. Ne les remplacer que par une pièce portant le numéro spécifié.

A

REF. NO.	PART NO.	DESCRIPTION	REMARK	REF. NO.	PART NO.	DESCRIPTION	REMARK
		<FILTER>				<IC>	
CF581	1-577-611-11	OSCILATOR, CERAMIC		IC072	8-759-073-14	IC X24C16P	
		<CONNECTOR>		IC201	8-759-073-30	IC TDA6612	
CN0001*	1-568-880-51	PIN, CONNECTOR 5P			8-759-073-31	IC TDA6622 (KV-S3411A, S3411B, S3411D, S3413E)	
CN0101	1-695-297-11	CONNECTOR, BOARD TO BOARD 20P (KV-S3411A, S3411D, S3412U, S3413E)		IC202	8-759-502-21	IC TDA2822M	
CN0102	1-573-296-11	CONNECTOR, BOARD TO BOARD 10P		IC251	8-759-072-99	IC TDA2052	
CN0103*	1-564-511-31	PLUG, CONNECTOR 8P		IC261	8-759-072-99	IC TDA2052	
CN0104*	1-568-882-51	PIN, CONNECTOR 7P		IC301	8-759-073-15	IC TDA9145/N1	
CN0105*	1-568-880-51	PIN, CONNECTOR 5P		IC302	8-759-084-91	IC TDA4661/V2	
CN0107*	1-568-879-51	PIN, CONNECTOR 4P		IC304	8-752-056-54	IC CXA15875	
CN0108*	1-568-878-51	PIN, CONNECTOR 3P		IC401	8-752-062-86	IC CXA1545AS	
CN0109	1-695-299-11	CONNECTOR, BOARD TO BOARD 50P		IC402	8-759-073-00	IC TEA2114	
CN0110*	1-568-882-51	PIN, CONNECTOR 7P		IC681	8-759-072-98	IC TDA8138A	
CN0111	1-568-882-51	PIN, CONNECTOR 7P		IC683	8-759-982-10	IC RC7809FA	
CN0113	1-695-298-11	CONNECTOR, BOARD TO BOARD 40P		IC684	8-759-982-10	IC RC7809FA	
CN0114*	1-568-879-51	PIN, CONNECTOR 4P				<IF BLOCK>	
CN0115*	1-564-516-11	PLUG, CONNECTOR 13P		IFB101	1-466-733-11	IF BLOCK (1FH-389) (KV-S3411A, S3411D, S3413E)	
CN0116*	1-568-879-11	PIN, CONNECTOR 4P			1-466-735-11	IF BLOCK (1FH-389F) (KV-S3411B)	
CN0119*	1-568-879-11	PIN, CONNECTOR 4P			1-466-734-11	IF BLOCK (1FH-395) (KV-S3412U)	
CN0137*	1-564-511-11	PLUG, CONNECTOR 8P				<COIL>	
CN5108*	1-564-513-41	PLUG, CONNECTOR 10P		L101	1-412-546-41	INDUCTOR 560UH	
		<DIODE>		L102	1-408-413-00	INDUCTOR 22UH	
D068	8-719-104-34	DIODE 1S2836		L201	1-407-500-00	INDUCTOR 4.7MMH	
D069	8-719-104-34	DIODE 1S2836		L306	1-408-405-00	INDUCTOR 4.7UH	
D071	8-719-109-89	DIODE RD5.6ES-B2		L307	1-408-405-00	INDUCTOR 4.7UH	
D073	8-719-109-89	DIODE RD5.6ES-B2		L308	1-408-417-00	INDUCTOR 47UH	
D075	8-719-400-18	DIODE MA152WK		L309	1-408-411-00	INDUCTOR 15UH	
D077	8-719-400-18	DIODE MA152WK		L310	1-410-396-41	INDUCTOR 0.45UH	
D078	8-719-109-89	DIODE RD5.6ES-B2		L572	1-410-119-11	INDUCTOR 1MMH	
D079	8-719-109-89	DIODE RD5.6ES-B2		L610	1-412-539-41	INDUCTOR 150UH	
D101	8-719-982-27	DIODE MTZJ-33C		L611	1-412-539-41	INDUCTOR 150UH	
D206	8-719-400-18	DIODE MA152WK				<IC LINK>	
D207	8-719-921-89	DIODE MTZJ-13C		PS681A	1-532-605-91	LINK IC 0.4A	
D208	8-719-911-19	DIODE 1SS119				<TRANSISTOR>	
D209	8-719-911-19	DIODE 1SS119		Q071	8-729-901-05	TRANSISTOR DTA124EK	
D210	8-719-911-19	DIODE 1SS119		Q101	8-729-216-22	TRANSISTOR 2SA1162-G	
D211	8-719-911-19	DIODE 1SS119		Q102	8-729-901-00	TRANSISTOR DTC124EK	
D212	8-719-911-19	DIODE 1SS119		Q103	8-729-900-53	TRANSISTOR DTC114EK	
D213	8-719-400-18	DIODE MA152WK		Q201	8-729-901-81	TRANSISTOR 2SC2412K-T-146-R	
D301	8-719-400-18	DIODE MA152WK		Q202	8-729-901-81	TRANSISTOR 2SC2412K-T-146-R	
D302	8-719-104-34	DIODE 1S2836		Q203	8-729-901-81	TRANSISTOR 2SC2412K-T-146-R	
D304	8-719-109-89	DIODE RD5.6ES-B2		Q204	8-729-216-22	TRANSISTOR 2SA1162-G	
D305	8-719-400-18	DIODE MA152WK		Q205	8-729-216-22	TRANSISTOR 2SA1162-G	
D306	8-719-400-18	DIODE MA152WK		Q206	8-729-216-22	TRANSISTOR 2SA1162-G	
D307	8-719-400-18	DIODE MA152WK		Q207	8-729-901-81	TRANSISTOR 2SC2412K-T-146-R	
D308	8-719-800-76	DIODE 1SS226		Q209	8-729-901-81	TRANSISTOR 2SC2412K-T-146-R	
D311	8-719-800-76	DIODE 1SS226		Q210	8-729-901-81	TRANSISTOR 2SC2412K-T-146-R	
D381	8-719-110-03	DIODE RD7.5ES-B2		Q301	8-729-901-00	TRANSISTOR DTC124EK	
D401	8-719-921-69	DIODE MTZJ-9.1		Q302	8-729-216-22	TRANSISTOR 2SA1162-G	
D403	8-719-921-69	DIODE MTZJ-9.1		Q303	8-729-216-22	TRANSISTOR 2SA1162-G	
D405	8-719-921-69	DIODE MTZJ-9.1		Q304	8-729-900-53	TRANSISTOR DTC114EK	
D406	8-719-921-69	DIODE MTZJ-9.1		Q305	8-729-901-01	TRANSISTOR DTC144EK	
D407	8-719-921-69	DIODE MTZJ-9.1		Q306	8-729-216-22	TRANSISTOR 2SA1162-G	
D571	8-719-800-76	DIODE 1SS226		Q308	8-729-216-22	TRANSISTOR 2SA1162-G	
D682	8-719-109-89	DIODE RD5.6ES-B2					

A

REF. NO.	PART NO.	DESCRIPTION	REMARK	REF. NO.	PART NO.	DESCRIPTION	REMARK
Q309	8-729-931-02	TRANSISTOR 2SC2413KQ		JR213	1-216-296-00	METAL GLAZE 0 5% 1/8W	
Q311	8-729-901-06	TRANSISTOR DTA144EK-T146		JR214	1-216-296-00	METAL GLAZE 0 5% 1/8W	
Q312	8-729-900-53	TRANSISTOR DTC114EK					
Q313	8-729-216-22	TRANSISTOR 2SA1162-G		JR215	1-216-296-00	METAL GLAZE 0 5% 1/8W	
Q401	8-729-901-81	TRANSISTOR 2SC2412K-T-146-R		JR216	1-216-296-00	METAL GLAZE 0 5% 1/8W	
Q402	8-729-901-81	TRANSISTOR 2SC2412K-T-146-R		JR217	1-216-296-00	METAL GLAZE 0 5% 1/8W	
Q403	8-729-901-81	TRANSISTOR 2SC2412K-T-146-R		JR218	1-216-296-00	METAL GLAZE 0 5% 1/8W	
Q404	8-729-901-81	TRANSISTOR 2SC2412K-T-146-R		JR219	1-216-296-00	METAL GLAZE 0 5% 1/8W	
Q581	8-729-901-81	TRANSISTOR 2SC2412K-T-146-R		JR220	1-216-296-00	METAL GLAZE 0 5% 1/8W	
Q582	8-729-216-22	TRANSISTOR 2SA1162-G		JR221	1-216-296-00	METAL GLAZE 0 5% 1/8W	
Q610	8-729-177-22	TRANSISTOR 2SB772-Q		JR222	1-216-296-00	METAL GLAZE 0 5% 1/8W	
Q611	8-729-900-53	TRANSISTOR DTC114EK		JR223	1-216-296-00	METAL GLAZE 0 5% 1/8W	
Q683	8-729-140-96	TRANSISTOR 2SD774-34		JR225	1-216-296-00	METAL GLAZE 0 5% 1/8W	
<RESISTOR>				JR226	1-216-296-00	METAL GLAZE 0 5% 1/8W	
JR101	1-216-295-00	METAL GLAZE 0 5% 1/10W		JR227	1-216-296-00	METAL GLAZE 0 5% 1/8W	
JR102	1-216-295-00	METAL GLAZE 0 5% 1/10W		JR228	1-216-296-00	METAL GLAZE 0 5% 1/8W	
JR104	1-216-295-00	METAL GLAZE 0 5% 1/10W		JR229	1-216-296-00	METAL GLAZE 0 5% 1/8W	
JR105	1-216-295-00	METAL GLAZE 0 5% 1/10W		JR230	1-216-296-00	METAL GLAZE 0 5% 1/8W	
JR107	1-216-295-00	METAL GLAZE 0 5% 1/10W		JR231	1-216-296-00	METAL GLAZE 0 5% 1/8W	
JR110	1-216-295-00	METAL GLAZE 0 5% 1/10W		JR232	1-216-296-00	METAL GLAZE 0 5% 1/8W	
JR111	1-216-295-00	METAL GLAZE 0 5% 1/10W		JR233	1-216-296-00	METAL GLAZE 0 5% 1/8W	
JR112	1-216-295-00	METAL GLAZE 0 5% 1/10W		JR234	1-216-296-00	METAL GLAZE 0 5% 1/8W	
JR113	1-216-295-00	METAL GLAZE 0 5% 1/10W		JR235	1-216-296-00	METAL GLAZE 0 5% 1/8W	
JR114	1-216-295-00	METAL GLAZE 0 5% 1/10W		JR236	1-216-296-00	METAL GLAZE 0 5% 1/8W	
JR115	1-216-295-00	METAL GLAZE 0 5% 1/10W		JR237	1-216-296-00	METAL GLAZE 0 5% 1/8W	
JR116	1-216-295-00	METAL GLAZE 0 5% 1/10W		JR238	1-216-296-00	METAL GLAZE 0 5% 1/8W	
JR117	1-216-295-00	METAL GLAZE 0 5% 1/10W		JR239	1-216-296-00	METAL GLAZE 0 5% 1/8W	
JR118	1-216-295-00	METAL GLAZE 0 5% 1/10W		JR240	1-216-296-00	METAL GLAZE 0 5% 1/8W	
JR119	1-216-295-00	METAL GLAZE 0 5% 1/10W		JR241	1-216-296-00	METAL GLAZE 0 5% 1/8W	
JR120	1-216-295-00	METAL GLAZE 0 5% 1/10W		JR242	1-216-296-00	METAL GLAZE 0 5% 1/8W	
JR121	1-216-295-00	METAL GLAZE 0 5% 1/10W		JR243	1-216-296-00	METAL GLAZE 0 5% 1/8W	
JR122	1-216-295-00	METAL GLAZE 0 5% 1/10W		JR245	1-216-296-00	METAL GLAZE 0 5% 1/8W	
JR123	1-216-295-00	METAL GLAZE 0 5% 1/10W		JR247	1-216-296-00	METAL GLAZE 0 5% 1/8W	
JR125	1-216-295-00	METAL GLAZE 0 5% 1/10W		JR248	1-216-296-00	METAL GLAZE 0 5% 1/8W	
JR127	1-216-295-00	METAL GLAZE 0 5% 1/10W		JR250	1-216-296-00	METAL GLAZE 0 5% 1/8W	
JR129	1-216-295-00	METAL GLAZE 0 5% 1/10W		JR251	1-216-296-00	METAL GLAZE 0 5% 1/8W	
JR131	1-216-295-00	METAL GLAZE 0 5% 1/10W		JR252	1-216-296-00	METAL GLAZE 0 5% 1/8W	
JR132	1-216-295-00	METAL GLAZE 0 5% 1/10W		JR253	1-216-296-00	METAL GLAZE 0 5% 1/8W	
JR133	1-216-295-00	METAL GLAZE 0 5% 1/10W		JR254	1-216-296-00	METAL GLAZE 0 5% 1/8W	
JR134	1-216-296-00	METAL GLAZE 0 5% 1/8W		JR255	1-216-295-00	METAL GLAZE 0 5% 1/10W	
JR136	1-216-295-00	METAL GLAZE 0 5% 1/10W		JR256	1-216-296-00	METAL GLAZE 0 5% 1/8W	
JR137	1-216-295-00	METAL GLAZE 0 5% 1/10W		JR257	1-216-295-00	METAL GLAZE 0 5% 1/10W	
JR138	1-216-295-00	METAL GLAZE 0 5% 1/10W		JR258	1-216-296-00	METAL GLAZE 0 5% 1/8W	
JR140	1-216-295-00	METAL GLAZE 0 5% 1/10W		JR270	1-216-295-00	METAL GLAZE 0 5% 1/10W	
JR141	1-216-295-00	METAL GLAZE 0 5% 1/10W		JR272	1-216-295-00	METAL GLAZE 0 5% 1/10W	
JR142	1-216-295-00	METAL GLAZE 0 5% 1/10W		R071	1-216-041-00	METAL GLAZE 470 5% 1/10W	
JR143	1-216-295-00	METAL GLAZE 0 5% 1/10W		R072	1-216-033-00	METAL GLAZE 220 5% 1/10W	
JR144	1-216-295-00	METAL GLAZE 0 5% 1/10W		R073	1-216-033-00	METAL GLAZE 220 5% 1/10W	
JR150	1-216-295-00	METAL GLAZE 0 5% 1/10W		R074	1-216-198-00	METAL GLAZE 1K 5% 1/8W	
JR152	1-216-295-00	METAL GLAZE 0 5% 1/10W		R076	1-216-057-00	METAL GLAZE 2.2K 5% 1/10W	
JR201A	1-216-296-00	METAL GLAZE 0 5% 1/8W		R077	1-216-025-00	METAL GLAZE 100 5% 1/10W	
JR202	1-216-296-00	METAL GLAZE 0 5% 1/8W		R101	1-216-025-00	METAL GLAZE 100 5% 1/10W	
JR203	1-216-296-00	METAL GLAZE 0 5% 1/8W		R102	1-216-049-00	METAL GLAZE 1K 5% 1/10W	
JR204	1-216-296-00	METAL GLAZE 0 5% 1/8W		R103	1-216-059-00	METAL GLAZE 2.7K 5% 1/10W	
JR205	1-216-296-00	METAL GLAZE 0 5% 1/8W		R105	1-216-073-00	METAL GLAZE 10K 5% 1/10W	
JR206	1-216-296-00	METAL GLAZE 0 5% 1/8W		R108	1-216-230-00	METAL GLAZE 22K 5% 1/8W	
JR207	1-216-296-00	METAL GLAZE 0 5% 1/8W		R115	1-216-210-00	METAL GLAZE 3.3K 5% 1/8W	
JR208	1-216-296-00	METAL GLAZE 0 5% 1/8W		R201	1-216-653-11	METAL CHIP 1.2K 0.50% 1/10W	
JR209	1-216-296-00	METAL GLAZE 0 5% 1/8W		R202	1-216-653-11	METAL CHIP 1.2K 0.50% 1/10W	
JR210	1-216-296-00	METAL GLAZE 0 5% 1/8W		R203	1-216-067-00	METAL GLAZE 5.6K 5% 1/10W	
JR211	1-216-296-00	METAL GLAZE 0 5% 1/8W		R204	1-216-091-00	METAL GLAZE 56K 5% 1/10W	
JR212	1-216-296-00	METAL GLAZE 0 5% 1/8W		R205	1-216-071-00	METAL GLAZE 8.2K 5% 1/10W	
				R206	1-216-071-00	METAL GLAZE 8.2K 5% 1/10W	
				R207	1-216-057-00	METAL GLAZE 2.2K 5% 1/10W	

REF. NO.	PART NO.	DESCRIPTION	REMARK	REF. NO.	PART NO.	DESCRIPTION	REMARK
R208	1-216-057-00	METAL GLAZE	2.2K 5% 1/10W	R316	1-216-085-00	METAL GLAZE	33K 5% 1/10W
R209	1-249-377-11	CARBON	0.47 5% 1/4W F	R317	1-216-073-00	METAL GLAZE	10K 5% 1/10W
R210	1-247-734-11	CARBON	39 5% 1/2W	R318	1-216-041-00	METAL GLAZE	470 5% 1/10W
R211	1-247-734-11	CARBON	39 5% 1/2W	R319	1-249-413-11	CARBON	470 5% 1/4W
R212	1-216-049-00	METAL GLAZE	1K 5% 1/10W	R320	1-216-174-00	METAL GLAZE	100 5% 1/8W
R213	1-216-073-00	METAL GLAZE	10K 5% 1/10W	R321	1-216-039-00	METAL GLAZE	390 5% 1/10W
R214	1-216-049-00	METAL GLAZE	1K 5% 1/10W	R322	1-216-041-00	METAL GLAZE	470 5% 1/10W
R215	1-216-073-00	METAL GLAZE	10K 5% 1/10W	R324	1-216-049-00	METAL GLAZE	1K 5% 1/10W
R216	1-216-049-00	METAL GLAZE	1K 5% 1/10W	R325	1-216-041-00	METAL GLAZE	470 5% 1/10W
R217	1-216-045-00	METAL GLAZE	680 5% 1/10W	R326	1-216-073-00	METAL GLAZE	10K 5% 1/10W
R218	1-216-081-00	METAL GLAZE	22K 5% 1/10W	R328	1-216-025-00	METAL GLAZE	100 5% 1/10W
R221	1-212-849-00	FUSIBLE	4.7 5% 1/4W F	R329	1-216-023-00	METAL GLAZE	82 5% 1/10W
R222	1-216-049-00	METAL GLAZE	1K 5% 1/10W	R330	1-216-053-00	METAL GLAZE	1.5K 5% 1/10W
R223	1-216-045-00	METAL GLAZE	680 5% 1/10W	R331	1-216-097-00	METAL GLAZE	100K 5% 1/10W
R224	1-249-433-11	CARBON	22K 5% 1/4W	R333	1-216-182-00	METAL GLAZE	220 5% 1/8W
R225	1-212-849-00	FUSIBLE	4.7 5% 1/4W F	R334	1-216-182-00	METAL GLAZE	220 5% 1/8W
R226	1-249-412-11	CARBON	390 5% 1/4W	R336	1-216-178-00	METAL GLAZE	150 5% 1/8W
R227	1-216-081-00	METAL GLAZE	22K 5% 1/10W	R337	1-216-041-00	METAL GLAZE	470 5% 1/10W
R228	1-216-081-00	METAL GLAZE	22K 5% 1/10W	R338	1-216-035-00	METAL GLAZE	270 5% 1/10W
R229	1-216-039-00	METAL GLAZE	390 5% 1/10W	R339	1-216-025-00	METAL GLAZE	100 5% 1/10W
R230	1-216-246-00	METAL GLAZE	100K 5% 1/8W	R340	1-216-025-00	METAL GLAZE	100 5% 1/10W
R231	1-216-097-00	METAL GLAZE	100K 5% 1/10W	R341	1-216-025-00	METAL GLAZE	100 5% 1/10W
R232	1-216-081-00	METAL GLAZE	22K 5% 1/10W	R342	1-216-033-00	METAL GLAZE	220 5% 1/10W
R233	1-216-071-00	METAL GLAZE	8.2K 5% 1/10W	R343	1-216-022-00	METAL GLAZE	75 5% 1/10W
R234	1-216-077-00	METAL GLAZE	15K 5% 1/10W	R344	1-216-022-00	METAL GLAZE	75 5% 1/10W
R235	1-216-073-00	METAL GLAZE	10K 5% 1/10W	R345	1-216-171-00	METAL GLAZE	75 5% 1/8W
R236	1-216-081-00	METAL GLAZE	22K 5% 1/10W	R346	1-216-022-00	METAL GLAZE	75 5% 1/10W
R237	1-216-025-00	METAL GLAZE	100 5% 1/10W	R347	1-216-083-00	METAL GLAZE	27K 5% 1/10W
R238	1-216-025-00	METAL GLAZE	100 5% 1/10W	R348	1-216-029-00	METAL GLAZE	150 5% 1/10W
R239	1-216-295-00	METAL GLAZE	0 5% 1/10W	R349	1-216-029-00	METAL GLAZE	150 5% 1/10W
R241	1-216-065-00	METAL GLAZE	4.7K 5% 1/10W	R350	1-216-178-00	METAL GLAZE	150 5% 1/8W
R242	1-216-214-00	METAL GLAZE	4.7K 5% 1/8W	R351	1-216-073-00	METAL GLAZE	10K 5% 1/10W
R244	1-216-069-00	METAL GLAZE	6.8K 5% 1/10W	R352	1-216-033-00	METAL GLAZE	220 5% 1/10W
R245	1-216-089-00	METAL GLAZE	47K 5% 1/10W	R354	1-216-033-00	METAL GLAZE	220 5% 1/10W
R246	1-216-097-00	METAL GLAZE	100K 5% 1/10W	R355	1-216-033-00	METAL GLAZE	220 5% 1/10W
R247	1-216-073-00	METAL GLAZE	10K 5% 1/10W	R356	1-216-033-00	METAL GLAZE	220 5% 1/10W
R248	1-216-073-00	METAL GLAZE	10K 5% 1/10W	R357	1-216-041-00	METAL GLAZE	470 5% 1/10W
R249	1-216-045-00	METAL GLAZE	680 5% 1/10W	R358	1-216-031-00	METAL GLAZE	180 5% 1/10W
R250	1-216-095-00	METAL GLAZE	82K 5% 1/10W	R359	1-216-033-00	METAL GLAZE	220 5% 1/10W
R251	1-216-065-00	METAL GLAZE	4.7K 5% 1/10W	R360	1-216-033-00	METAL GLAZE	220 5% 1/10W
R252	1-216-073-00	METAL GLAZE	10K 5% 1/10W	R361	1-216-033-00	METAL GLAZE	220 5% 1/10W
R253	1-216-073-00	METAL GLAZE	10K 5% 1/10W	R362	1-216-077-00	METAL GLAZE	15K 5% 1/10W
R254	1-216-252-00	METAL GLAZE	180K 5% 1/8W	R365	1-216-073-00	METAL GLAZE	10K 5% 1/10W
R255	1-216-252-00	METAL GLAZE	180K 5% 1/8W	R366	1-216-067-00	METAL GLAZE	5.6K 5% 1/10W
R256	1-249-409-11	CARBON	220 5% 1/4W	R367	1-216-212-00	METAL GLAZE	3.9K 5% 1/8W
R257	1-249-409-11	CARBON	220 5% 1/4W	R368	1-216-033-00	METAL GLAZE	220 5% 1/10W
R258	1-216-089-00	METAL GLAZE	47K 5% 1/10W	R369	1-216-033-00	METAL GLAZE	220 5% 1/10W
R259	1-216-063-00	METAL GLAZE	3.9K 5% 1/10W	R370	1-216-033-00	METAL GLAZE	220 5% 1/10W
R260	1-216-212-00	METAL GLAZE	3.9K 5% 1/8W	R371	1-216-033-00	METAL GLAZE	220 5% 1/10W
R301	1-216-041-00	METAL GLAZE	470 5% 1/10W	R373	1-216-017-00	METAL GLAZE	47 5% 1/10W
R302	1-216-041-00	METAL GLAZE	470 5% 1/10W	R376	1-216-065-00	METAL GLAZE	4.7K 5% 1/10W
R303	1-216-174-00	METAL GLAZE	100 5% 1/8W	R377	1-216-051-00	METAL GLAZE	1.2K 5% 1/10W
R304	1-216-174-00	METAL GLAZE	100 5% 1/8W	R378	1-216-057-00	METAL GLAZE	2.2K 5% 1/10W
R305	1-216-035-00	METAL GLAZE	270 5% 1/10W	R379	1-216-206-00	METAL GLAZE	2.2K 5% 1/8W
R306	1-216-035-00	METAL GLAZE	270 5% 1/10W	R380	1-216-057-00	METAL GLAZE	2.2K 5% 1/10W
R307	1-216-075-00	METAL GLAZE	12K 5% 1/10W	R381	1-216-164-00	METAL GLAZE	39 5% 1/8W
R308	1-216-121-00	METAL GLAZE	1M 5% 1/10W	R382	1-216-164-00	METAL GLAZE	39 5% 1/8W
R309	1-216-001-00	METAL GLAZE	10 5% 1/10W	R383	1-216-164-00	METAL GLAZE	39 5% 1/8W
R310	1-216-001-00	METAL GLAZE	10 5% 1/10W	R401	1-216-171-00	METAL GLAZE	75 5% 1/8W
R311	1-216-065-00	METAL GLAZE	4.7K 5% 1/10W	R402	1-216-158-00	METAL GLAZE	22 5% 1/8W
R312	1-249-413-11	CARBON	470 5% 1/4W	R403	1-216-025-00	METAL GLAZE	100 5% 1/10W
R313	1-216-081-00	METAL GLAZE	22K 5% 1/10W	R404	1-216-158-00	METAL GLAZE	22 5% 1/8W
R314	1-249-409-11	CARBON	220 5% 1/4W	R405	1-216-025-00	METAL GLAZE	100 5% 1/10W
R315	1-249-409-11	CARBON	220 5% 1/4W				

IF (KV-S3411A/S3411D)
S3413F

IF (KV-S3411B)

REF. NO.	PART NO.	DESCRIPTION	REMARK	REF. NO.	PART NO.	DESCRIPTION	REMARK
<COIL>				R120	1-216-075-00	METAL GLAZE 12K 5%	1/10W
L101	1-408-421-00	INDUCTOR 100UH		R121	1-216-053-00	METAL GLAZE 1.5K 5%	1/10W
L102	1-408-419-00	INDUCTOR 68UH		R122	1-216-061-00	METAL GLAZE 3.3K 5%	1/10W
L103	1-408-419-00	INDUCTOR 68UH		R123	1-216-075-00	METAL GLAZE 12K 5%	1/10W
L104	1-408-408-00	INDUCTOR 8.2UH		R124	1-216-041-00	METAL GLAZE 470 5%	1/10W
L121	1-408-413-00	INDUCTOR 22UH		R125	1-216-041-00	METAL GLAZE 470 5%	1/10W
L122	1-408-420-00	INDUCTOR 82UH		R127	1-216-047-00	METAL GLAZE 820 5%	1/10W
L142	1-410-790-41	INDUCTOR 0.56UH		R130	1-216-049-00	METAL GLAZE 1K 5%	1/10W
L151	1-408-419-00	INDUCTOR 68UH		R131	1-216-025-00	METAL GLAZE 100 5%	1/10W
L161	1-408-419-00	INDUCTOR 68UH		R132	1-216-069-00	METAL GLAZE 6.8K 5%	1/10W
<TRANSISTOR>				R133	1-216-061-00	METAL GLAZE 3.3K 5%	1/10W
Q101	8-729-120-28	TRANSISTOR 2SC1623-L5L6		R134	1-216-049-00	METAL GLAZE 1K 5%	1/10W
Q102	8-729-216-22	TRANSISTOR 2SA1162-G		R135	1-216-198-00	METAL GLAZE 1K 5%	1/8W
Q121	8-729-120-28	TRANSISTOR 2SC1623-L5L6		R150	1-216-043-00	METAL GLAZE 560 5%	1/10W
Q122	8-729-216-22	TRANSISTOR 2SA1162-G		R151	1-216-043-00	METAL GLAZE 560 5%	1/10W
Q161	8-729-216-22	TRANSISTOR 2SA1162-G		R152	1-216-043-00	METAL GLAZE 560 5%	1/10W
Q170	8-729-120-28	TRANSISTOR 2SC1623-L5L6		R153	1-216-025-00	METAL GLAZE 100 5%	1/10W
Q171	8-729-120-28	TRANSISTOR 2SC1623-L5L6		R154	1-216-049-00	METAL GLAZE 1K 5%	1/10W
Q172	8-729-120-28	TRANSISTOR 2SC1623-L5L6		R155	1-216-051-00	METAL GLAZE 1.2K 5%	1/10W
Q173	8-729-120-28	TRANSISTOR 2SC1623-L5L6		R156	1-216-083-00	METAL GLAZE 27K 5%	1/10W
<RESISTOR>				R157	1-216-051-00	METAL GLAZE 1.2K 5%	1/10W
JR2	1-216-295-00	METAL GLAZE 0 5%	1/10W	R159	1-216-107-00	METAL GLAZE 270K 5%	1/10W
JR3	1-216-296-00	METAL GLAZE 0 5%	1/8W	R160	1-216-049-00	METAL GLAZE 1K 5%	1/10W
JR4	1-216-295-00	METAL GLAZE 0 5%	1/10W	R161	1-218-755-11	METAL CHIP 130K 0.50%	1/10W
JR7	1-216-295-00	METAL GLAZE 0 5%	1/10W	R162	1-216-073-00	METAL GLAZE 10K 5%	1/10W
JR8	1-216-295-00	METAL GLAZE 0 5%	1/10W	R163	1-216-113-00	METAL GLAZE 470K 5%	1/10W
JR9	1-216-296-00	METAL GLAZE 0 5%	1/8W	R164	1-216-113-00	METAL GLAZE 470K 5%	1/10W
JR11	1-216-296-00	METAL GLAZE 0 5%	1/8W	R165	1-216-081-00	METAL GLAZE 22K 5%	1/10W
JR14	1-216-296-00	METAL GLAZE 0 5%	1/8W	R166	1-216-049-00	METAL GLAZE 1K 5%	1/10W
JR16	1-216-295-00	METAL GLAZE 0 5%	1/10W	R167	1-216-073-00	METAL GLAZE 10K 5%	1/10W
JR18	1-216-295-00	METAL GLAZE 0 5%	1/10W	R168	1-216-113-00	METAL GLAZE 470K 5%	1/10W
JR19	1-216-296-00	METAL GLAZE 0 5%	1/8W	R169	1-216-049-00	METAL GLAZE 1K 5%	1/10W
JR20	1-216-296-00	METAL GLAZE 0 5%	1/8W	R170	1-216-083-00	METAL GLAZE 27K 5%	1/10W
JR21	1-216-296-00	METAL GLAZE 0 5%	1/8W	R171	1-216-075-00	METAL GLAZE 12K 5%	1/10W
JR23	1-216-296-00	METAL GLAZE 0 5%	1/8W	R172	1-216-095-00	METAL GLAZE 82K 5%	1/10W
JR24	1-216-296-00	METAL GLAZE 0 5%	1/8W	R173	1-216-059-00	METAL GLAZE 2.7K 5%	1/10W
JR25	1-216-296-00	METAL GLAZE 0 5%	1/8W	R174	1-216-057-00	METAL GLAZE 2.2K 5%	1/10W
JR29	1-216-296-00	METAL GLAZE 0 5%	1/8W	R175	1-216-083-00	METAL GLAZE 27K 5%	1/10W
JR30	1-216-295-00	METAL GLAZE 0 5%	1/10W	R176	1-216-075-00	METAL GLAZE 12K 5%	1/10W
JR33	1-216-295-00	METAL GLAZE 0 5%	1/10W	R177	1-216-095-00	METAL GLAZE 82K 5%	1/10W
JR38	1-216-296-00	METAL GLAZE 0 5%	1/8W	R178	1-216-059-00	METAL GLAZE 2.7K 5%	1/10W
JR39	1-216-296-00	METAL GLAZE 0 5%	1/8W	R179	1-216-057-00	METAL GLAZE 2.2K 5%	1/10W
JR40	1-216-296-00	METAL GLAZE 0 5%	1/8W	R180	1-216-037-00	METAL GLAZE 330 5%	1/10W
R101	1-216-075-00	METAL GLAZE 12K 5%	1/10W	R181	1-216-037-00	METAL GLAZE 330 5%	1/10W
R102	1-216-073-00	METAL GLAZE 10K 5%	1/10W	<VARIABLE RESISTOR>			
R103	1-216-057-00	METAL GLAZE 2.2K 5%	1/10W	RV1	1-241-121-11	RES, ADJ. CARBON 4.7K	
R104	1-216-051-00	METAL GLAZE 1.2K 5%	1/10W	<TRANSFORMER>			
R106	1-216-049-00	METAL GLAZE 1K 5%	1/10W	T4	1-416-017-21	COIL	
R107	1-216-065-00	METAL GLAZE 4.7K 5%	1/10W	T5	1-416-018-21	COIL	
R108	1-216-065-00	METAL GLAZE 4.7K 5%	1/10W	*****			
R110	1-216-041-00	METAL GLAZE 470 5%	1/10W		1-466-735-11	IF BLOCK (1FH-389F) (KV-S3411B)	
R113	1-216-031-00	METAL GLAZE 180 5%	1/10W	*****			
R114	1-216-049-00	METAL GLAZE 1K 5%	1/10W	<CAPACITOR>			
R115	1-216-027-00	METAL GLAZE 120 5%	1/10W	C1	1-163-017-00	CERAMIC CHIP 0.0047MF	10% 50V
R116	1-216-101-00	METAL GLAZE 150K 5%	1/10W	C2	1-164-232-11	CERAMIC CHIP 0.01MF	10% 50V
R117	1-216-097-00	METAL GLAZE 100K 5%	1/10W	C3	1-124-903-11	ELECT 1MF	20% 50V
R118	1-216-117-00	METAL GLAZE 680K 5%	1/10W				
R119	1-216-240-00	METAL GLAZE 56K 5%	1/8W				

IF (KV-S3411B)

REF. NO.	PART NO.	DESCRIPTION	REMARK	REF. NO.	PART NO.	DESCRIPTION	REMARK
C4	1-164-232-11	CERAMIC CHIP 0.01MF	10% 50V				
C5	1-164-232-11	CERAMIC CHIP 0.01MF	10% 50V				
C6	1-163-017-00	CERAMIC CHIP 0.0047MF	10% 50V				
C7	1-164-232-11	CERAMIC CHIP 0.01MF	10% 50V				
C8	1-163-017-00	CERAMIC CHIP 0.0047MF	10% 50V				
C9	1-124-916-11	ELECT 22MF	20% 25V				
C10	1-164-232-11	CERAMIC CHIP 0.01MF	10% 50V				
C11	1-124-477-11	ELECT 47MF	20% 16V				
C13	1-163-059-00	CERAMIC CHIP 0.01MF	10% 50V				
C14	1-124-477-11	ELECT 47MF	20% 16V				
C15	1-124-903-11	ELECT 1MF	20% 50V				
C16	1-163-061-00	CERAMIC CHIP 0.015MF	10% 50V				
C17	1-162-638-11	CERAMIC CHIP 1MF	16V				
C18	1-162-638-11	CERAMIC CHIP 1MF	16V				
C19	1-163-141-00	CERAMIC CHIP 0.001MF	5% 50V				
C20	1-124-902-00	ELECT 0.47MF	20% 50V				
C21	1-124-903-11	ELECT 1MF	20% 50V				
C22	1-164-232-11	CERAMIC CHIP 0.01MF	10% 50V				
C23	1-124-902-00	ELECT 0.47MF	20% 50V				
C24	1-164-506-11	CERAMIC CHIP 4.7MF	16V				
C25	1-124-477-11	ELECT 47MF	20% 16V				
C26	1-164-232-11	CERAMIC CHIP 0.01MF	10% 50V				
C27	1-164-232-11	CERAMIC CHIP 0.01MF	10% 50V				
C28	1-124-477-11	ELECT 47MF	20% 16V				
C33	1-124-907-11	ELECT 10MF	20% 50V				
C34	1-124-907-11	ELECT 10MF	20% 50V				
C35	1-124-925-11	ELECT 2.2MF	20% 50V				
C36	1-124-477-11	ELECT 47MF	20% 16V				
C37	1-164-232-11	CERAMIC CHIP 0.01MF	10% 50V				
C38	1-163-017-00	CERAMIC CHIP 0.0047MF	10% 50V				
C40	1-164-232-11	CERAMIC CHIP 0.01MF	10% 50V				
C71	1-124-477-11	ELECT 47MF	20% 16V				
C72	1-164-232-11	CERAMIC CHIP 0.01MF	10% 50V				
C80	1-124-477-11	ELECT 47MF	20% 16V				
C83	1-124-477-11	ELECT 47MF	20% 16V				
C84	1-124-477-11	ELECT 47MF	20% 16V				
C85	1-124-477-11	ELECT 47MF	20% 16V				
C86	1-124-477-11	ELECT 47MF	20% 16V				
C87	1-124-477-11	ELECT 47MF	20% 16V				
C91	1-163-229-11	CERAMIC CHIP 12PF	5% 50V				
C95	1-164-337-11	CERAMIC CHIP 2.2MF	16V				
C101	1-163-017-00	CERAMIC CHIP 0.0047MF	10% 50V				
C102	1-163-017-00	CERAMIC CHIP 0.0047MF	10% 50V				
C104	1-163-017-00	CERAMIC CHIP 0.0047MF	10% 50V				
C105	1-163-017-00	CERAMIC CHIP 0.0047MF	10% 50V				
C106	1-163-017-00	CERAMIC CHIP 0.0047MF	10% 50V				
C121	1-126-176-11	ELECT 220MF	20% 10V				
C122	1-163-119-00	CERAMIC CHIP 120PF	5% 50V				
C131	1-126-099-11	ELECT 2.2MF	20% 35V				
<FILTER>							
CF1	1-527-839-00	FILTER, CERAMIC					
CF2	1-567-569-11	FILTER, CERAMIC					
CF3	1-527-840-00	FILTER, CERAMIC					
CF4	1-567-570-11	FILTER, CERAMIC					
SWF1	1-579-662-11	FILTER, SURFACE WAVE					
SWF3	1-404-711-11	SAWF					
SWF4	1-579-660-11	FILTER, SAWTOOTH WAVE					
<CONNECTOR>							
CN1	1-750-173-11	PIN, CONNECTOR (PC BOARD)	10P				
CN2	1-750-173-11	PIN, CONNECTOR (PC BOARD)	10P				
<TRIMMER>							
CT1	1-404-801-11	TRAP, CERAMIC					
CT2	1-409-429-11	TRAP, CERAMIC					
CV1	1-141-245-00	CAP, TRIMMER					
CV2	1-141-245-00	CAP, TRIMMER					
CV3	1-141-304-21	TRIMMER, CERAMIC					
<DIODE>							
D7	8-719-421-57	DIODE MA73-TX					
D8	8-719-421-57	DIODE MA73-TX					
D9	8-719-421-57	DIODE MA73-TX					
<IC>							
IC1	8-759-070-75	IC M52312SP					
IC2	8-759-070-71	IC TDA9820					
IC3	8-759-979-62	IC PCF8574					
<COIL>							
L1	1-408-419-00	INDUCTOR	680H				
L2	1-408-419-00	INDUCTOR	680H				
L3	1-408-407-00	INDUCTOR	6.80H				
L4	1-408-419-00	INDUCTOR	680H				
L5	1-408-419-00	INDUCTOR	680H				
L7	1-408-406-00	INDUCTOR	5.60H				
L9	1-408-419-00	INDUCTOR	680H				
L71	1-408-419-00	INDUCTOR	680H				
L101	1-408-399-00	INDUCTOR	1.50H				
L121	1-408-407-00	INDUCTOR	6.80H				
<TRANSISTOR>							
Q1	8-729-907-06	TRANSISTOR BF199-AMMO					
Q4	8-729-120-28	TRANSISTOR 2SC1623-L5L6					
Q5	8-729-115-10	TRANSISTOR 2SK105A-10					
Q6	8-729-900-52	TRANSISTOR DTC114YK					
Q7	8-729-216-22	TRANSISTOR 2SA1162-G					
Q8	8-729-120-28	TRANSISTOR 2SC1623-L5L6					
Q10	8-729-120-28	TRANSISTOR 2SC1623-L5L6					
Q11	8-729-120-28	TRANSISTOR 2SC1623-L5L6					
Q12	8-729-120-28	TRANSISTOR 2SC1623-L5L6					
Q13	8-729-120-28	TRANSISTOR 2SC1623-L5L6					
Q14	8-729-120-28	TRANSISTOR 2SC1623-L5L6					
Q15	8-729-120-28	TRANSISTOR 2SC1623-L5L6					
Q16	8-729-216-22	TRANSISTOR 2SA1162-G					
Q101	8-729-104-80	TRANSISTOR 2SC3355					
Q121	8-729-120-28	TRANSISTOR 2SC1623-L5L6					
<RESISTOR>							
JR2	1-216-295-00	METAL GLAZE	0 5%	1/10W			
JR3	1-216-296-00	METAL GLAZE	0 5%	1/8W			
JR5	1-216-296-00	METAL GLAZE	0 5%	1/8W			
R1	1-216-025-00	METAL GLAZE	100 5%	1/10W			
R2	1-216-065-00	METAL GLAZE	4.7K 5%	1/10W			
R3	1-216-065-00	METAL GLAZE	4.7K 5%	1/10W			
R4	1-216-041-00	METAL GLAZE	470 5%	1/10W			
R5	1-216-021-00	METAL GLAZE	68 5%	1/10W			
R6	1-216-055-00	METAL GLAZE	1.8K 5%	1/10W			
R8	1-216-051-00	METAL GLAZE	1.2K 5%	1/10W			
R9	1-216-069-00	METAL GLAZE	6.8K 5%	1/10W			

IF (KV-S3411B)

IF (KV-S3412U)

REF. NO.	PART NO.	DESCRIPTION	REMARK	REF. NO.	PART NO.	DESCRIPTION	REMARK
R10	1-216-071-00	METAL GLAZE	8.2K 5% 1/10W	R102	1-216-065-00	METAL GLAZE	4.7K 5% 1/10W
R11	1-216-059-00	METAL GLAZE	2.7K 5% 1/10W	R103	1-216-063-00	METAL GLAZE	3.9K 5% 1/10W
R24	1-216-280-00	METAL GLAZE	2.7M 5% 1/8W	R104	1-216-049-00	METAL GLAZE	1K 5% 1/10W
R25	1-216-057-00	METAL GLAZE	2.2K 5% 1/10W	R105	1-216-033-00	METAL GLAZE	220 5% 1/10W
R26	1-216-061-00	METAL GLAZE	3.3K 5% 1/10W	R121	1-216-073-00	METAL GLAZE	10K 5% 1/10W
R27	1-216-266-00	METAL GLAZE	680K 5% 1/8W	R122	1-216-065-00	METAL GLAZE	4.7K 5% 1/10W
R28	1-216-075-00	METAL GLAZE	12K 5% 1/10W	R123	1-216-041-00	METAL GLAZE	470 5% 1/10W
R29	1-216-035-00	METAL GLAZE	270 5% 1/10W	R124	1-216-041-00	METAL GLAZE	470 5% 1/10W
R30	1-216-049-00	METAL GLAZE	1K 5% 1/10W	R125	1-216-041-00	METAL GLAZE	470 5% 1/10W
R31	1-216-017-00	METAL GLAZE	47 5% 1/10W	R301	1-216-049-00	METAL GLAZE	1K 5% 1/10W
R32	1-216-043-00	METAL GLAZE	560 5% 1/10W	R302	1-216-049-00	METAL GLAZE	1K 5% 1/10W
R33	1-216-037-00	METAL GLAZE	330 5% 1/10W	R303	1-216-049-00	METAL GLAZE	1K 5% 1/10W
R34	1-216-252-00	METAL GLAZE	180K 5% 1/8W	R304	1-216-037-00	METAL GLAZE	330 5% 1/10W
R35	1-216-035-00	METAL GLAZE	270 5% 1/10W	R305	1-216-049-00	METAL GLAZE	1K 5% 1/10W
R36	1-216-029-00	METAL GLAZE	150 5% 1/10W	R306	1-216-025-00	METAL GLAZE	100 5% 1/10W
R37	1-216-049-00	METAL GLAZE	1K 5% 1/10W	R307	1-216-037-00	METAL GLAZE	330 5% 1/10W
R38	1-216-099-00	METAL GLAZE	120K 5% 1/10W	R308	1-216-037-00	METAL GLAZE	330 5% 1/10W
R39	1-216-089-00	METAL GLAZE	47K 5% 1/10W			<VARIABLE RESISTOR>	
R40	1-216-049-00	METAL GLAZE	1K 5% 1/10W	RV2	1-241-120-11	RES, ADJ, CARBON	2.2K
R42	1-216-061-00	METAL GLAZE	3.3K 5% 1/10W			<TRANSFORMER>	
R43	1-216-067-00	METAL GLAZE	5.6K 5% 1/10W	T1	1-404-806-21	COIL	
R44	1-216-027-00	METAL GLAZE	120 5% 1/10W	T3	1-416-012-11	COIL	
R45	1-216-041-00	METAL GLAZE	470 5% 1/10W	T4	1-416-012-11	COIL	
R46	1-216-031-00	METAL GLAZE	180 5% 1/10W	T5	1-402-720-11	COIL	
R47	1-216-075-00	METAL GLAZE	12K 5% 1/10W			<CRYSTAL>	
R48	1-216-081-00	METAL GLAZE	22K 5% 1/10W	X1	1-579-648-21	VIBRATOR, CERAMIC	
R49	1-216-049-00	METAL GLAZE	1K 5% 1/10W			*****	
R53	1-216-082-00	METAL GLAZE	24K 5% 1/10W			1-466-734-11	IF BLOCK (IFH-395) (KV-S3412U)
R54	1-216-043-00	METAL GLAZE	560 5% 1/10W			*****	
R55	1-216-043-00	METAL GLAZE	560 5% 1/10W			<CAPACITOR>	
R56	1-216-065-00	METAL GLAZE	4.7K 5% 1/10W	C101	1-163-239-11	CERAMIC CHIP	33PF 5% 50V
R57	1-216-065-00	METAL GLAZE	4.7K 5% 1/10W	C102	1-164-222-11	CERAMIC CHIP	0.22MF 25V
R58	1-216-041-00	METAL GLAZE	470 5% 1/10W	C103	1-164-232-11	CERAMIC CHIP	0.01MF 10% 50V
R59	1-216-043-00	METAL GLAZE	560 5% 1/10W	C104	1-164-232-11	CERAMIC CHIP	0.01MF 10% 50V
R60	1-216-043-00	METAL GLAZE	560 5% 1/10W	C105	1-164-004-11	CERAMIC CHIP	0.1MF 10% 25V
R61	1-216-295-00	METAL GLAZE	0 5% 1/10W	C106	1-124-477-11	ELECT	47MF 20% 16V
R63	1-216-043-00	METAL GLAZE	560 5% 1/10W	C107	1-164-004-11	CERAMIC CHIP	0.1MF 10% 25V
R71	1-216-079-00	METAL GLAZE	18K 5% 1/10W	C108	1-164-004-11	CERAMIC CHIP	0.1MF 10% 25V
R72	1-216-079-00	METAL GLAZE	18K 5% 1/10W	C109	1-164-232-11	CERAMIC CHIP	0.01MF 10% 50V
R73	1-216-049-00	METAL GLAZE	1K 5% 1/10W	C112	1-164-004-11	CERAMIC CHIP	0.1MF 10% 25V
R74	1-216-079-00	METAL GLAZE	18K 5% 1/10W	C113	1-163-101-00	CERAMIC CHIP	22PF 5% 50V
R75	1-216-079-00	METAL GLAZE	18K 5% 1/10W	C114	1-124-477-11	ELECT	47MF 20% 16V
R76	1-216-025-00	METAL GLAZE	100 5% 1/10W	C115	1-164-232-11	CERAMIC CHIP	0.01MF 10% 50V
R77	1-216-174-00	METAL GLAZE	100 5% 1/8W	C116	1-164-346-11	CERAMIC CHIP	1MF 16V
R81	1-216-095-00	METAL GLAZE	82K 5% 1/10W	C118	1-164-004-11	CERAMIC CHIP	0.1MF 10% 25V
R82	1-216-121-00	METAL GLAZE	1M 5% 1/10W	C119	1-163-369-11	CERAMIC CHIP	47PF 5% 50V
R83	1-216-025-00	METAL GLAZE	100 5% 1/10W	C122	1-163-093-00	CERAMIC CHIP	10PF 5% 50V
R84	1-216-085-00	METAL GLAZE	33K 5% 1/10W	C130	1-216-295-00	METAL GLAZE	0 5% 1/10W
R85	1-216-085-00	METAL GLAZE	33K 5% 1/10W	C131	1-163-224-11	CERAMIC CHIP	7PF 0.25PF 50V
R86	1-216-689-11	METAL GLAZE	39K 5% 1/10W	C133	1-124-477-11	ELECT	47MF 20% 16V
R87	1-216-095-00	METAL GLAZE	82K 5% 1/10W	C161	1-163-117-00	CERAMIC CHIP	100PF 5% 50V
R88	1-216-095-00	METAL GLAZE	82K 5% 1/10W	C162	1-164-222-11	CERAMIC CHIP	0.22MF 25V
R89	1-216-095-00	METAL GLAZE	82K 5% 1/10W	C163	1-164-346-11	CERAMIC CHIP	1MF 16V
R90	1-216-075-00	METAL GLAZE	12K 5% 1/10W	C164	1-163-141-00	CERAMIC CHIP	0.001MF 5% 50V
R91	1-216-295-00	METAL GLAZE	0 5% 1/10W				
R92	1-216-075-00	METAL GLAZE	12K 5% 1/10W				
R93	1-216-075-00	METAL GLAZE	12K 5% 1/10W				
R94	1-216-059-00	METAL GLAZE	2.7K 5% 1/10W				
R95	1-216-059-00	METAL GLAZE	2.7K 5% 1/10W				
R96	1-216-059-00	METAL GLAZE	2.7K 5% 1/10W				
R97	1-216-057-00	METAL GLAZE	2.2K 5% 1/10W				
R98	1-216-057-00	METAL GLAZE	2.2K 5% 1/10W				
R99	1-216-057-00	METAL GLAZE	2.2K 5% 1/10W				
R100	1-216-065-00	METAL GLAZE	4.7K 5% 1/10W				

IF (KV-S3412U)

REF. NO.	PART NO.	DESCRIPTION	REMARK	REF. NO.	PART NO.	DESCRIPTION	REMARK
C165	1-164-232-11	CERAMIC CHIP 0.01MF	10% 50V	JR14	1-216-296-00	METAL GLAZE 0 5% 1/8W	
C166	1-124-477-11	ELECT 47MF	20% 16V	JR16	1-216-295-00	METAL GLAZE 0 5% 1/10W	
C167	1-163-213-00	CERAMIC CHIP 0.0022MF	5% 50V	JR18	1-216-295-00	METAL GLAZE 0 5% 1/10W	
C168	1-164-346-11	CERAMIC CHIP 1MF	16V	JR19	1-216-296-00	METAL GLAZE 0 5% 1/8W	
C170	1-124-477-11	ELECT 47MF	20% 16V	JR20	1-216-296-00	METAL GLAZE 0 5% 1/8W	
C171	1-124-477-11	ELECT 47MF	20% 16V	JR21	1-216-296-00	METAL GLAZE 0 5% 1/8W	
<FILTER>				JR23	1-216-296-00	METAL GLAZE 0 5% 1/8W	
CD1	1-579-657-21	DISCRIMINATOR, CERAMIC		JR24	1-216-296-00	METAL GLAZE 0 5% 1/8W	
CF1	1-567-569-11	FILTER, CERAMIC		JR25	1-216-296-00	METAL GLAZE 0 5% 1/8W	
SWF1	1-579-659-11	FILTER, SAWTOOTH WAVE		JR29	1-216-296-00	METAL GLAZE 0 5% 1/8W	
<CONNECTOR>				JR30	1-216-295-00	METAL GLAZE 0 5% 1/10W	
CN1	1-750-173-11	PIN, CONNECTOR (PC BOARD) 10P		JR33	1-216-295-00	METAL GLAZE 0 5% 1/10W	
CN2	1-750-173-11	PIN, CONNECTOR (PC BOARD) 10P		JR38	1-216-296-00	METAL GLAZE 0 5% 1/8W	
<TRIMMER>				JR39	1-216-296-00	METAL GLAZE 0 5% 1/8W	
CT1	1-409-333-00	TRAP, CERAMIC (6.0MHZ)		JR40	1-216-296-00	METAL GLAZE 0 5% 1/8W	
<DIODE>				JR41	1-216-295-00	METAL GLAZE 0 5% 1/10W	
D161	8-719-400-18	DIODE MA152WK		JR42	1-216-295-00	METAL GLAZE 0 5% 1/10W	
<IC>				JR101	1-216-295-00	METAL GLAZE 0 5% 1/10W	
IC1	8-759-070-76	IC M52308SP		R101	1-216-075-00	METAL GLAZE 12K 5% 1/10W	
IC3	8-759-514-54	IC BA7046		R102	1-216-045-00	METAL GLAZE 680 5% 1/10W	
<COIL>				R103	1-216-057-00	METAL GLAZE 2.2K 5% 1/10W	
L101	1-408-414-00	INDUCTOR 27UH		R104	1-216-051-00	METAL GLAZE 1.2K 5% 1/10W	
L102	1-408-419-00	INDUCTOR 68UH		R105	1-216-043-00	METAL GLAZE 560 5% 1/10W	
L103	1-408-419-00	INDUCTOR 68UH		R106	1-216-049-00	METAL GLAZE 1K 5% 1/10W	
L104	1-408-406-00	INDUCTOR 5.6UH		R107	1-216-065-00	METAL GLAZE 4.7K 5% 1/10W	
L105	1-408-410-00	INDUCTOR 12UH		R108	1-216-065-00	METAL GLAZE 4.7K 5% 1/10W	
L142	1-410-790-41	INDUCTOR 0.56UH		R110	1-216-041-00	METAL GLAZE 470 5% 1/10W	
L161	1-408-419-00	INDUCTOR 68UH		R112	1-216-045-00	METAL GLAZE 680 5% 1/10W	
<TRANSISTOR>				R113	1-216-031-00	METAL GLAZE 180 5% 1/10W	
Q101	8-729-120-28	TRANSISTOR 2SC1623-L5L6		R114	1-216-049-00	METAL GLAZE 1K 5% 1/10W	
Q102	8-729-216-22	TRANSISTOR 2SA1162-G		R115	1-216-031-00	METAL GLAZE 180 5% 1/10W	
Q122	8-729-216-22	TRANSISTOR 2SA1162-G		R116	1-216-101-00	METAL GLAZE 150K 5% 1/10W	
Q161	8-729-216-22	TRANSISTOR 2SA1162-G		R117	1-216-097-00	METAL GLAZE 100K 5% 1/10W	
Q172	8-729-120-28	TRANSISTOR 2SC1623-L5L6		R118	1-216-117-00	METAL GLAZE 680K 5% 1/10W	
Q173	8-729-120-28	TRANSISTOR 2SC1623-L5L6		R119	1-216-240-00	METAL GLAZE 56K 5% 1/8W	
<RESISTOR>				R120	1-216-075-00	METAL GLAZE 12K 5% 1/10W	
JR1	1-216-296-00	METAL GLAZE 0 5% 1/8W		R121	1-216-053-00	METAL GLAZE 1.5K 5% 1/10W	
JR2	1-216-295-00	METAL GLAZE 0 5% 1/10W		R122	1-216-061-00	METAL GLAZE 3.3K 5% 1/10W	
JR3	1-216-296-00	METAL GLAZE 0 5% 1/8W		R123	1-216-061-00	METAL GLAZE 3.3K 5% 1/10W	
JR4	1-216-295-00	METAL GLAZE 0 5% 1/10W		R130	1-216-049-00	METAL GLAZE 1K 5% 1/10W	
JR7	1-216-295-00	METAL GLAZE 0 5% 1/10W		R131	1-216-025-00	METAL GLAZE 100 5% 1/10W	
JR8	1-216-295-00	METAL GLAZE 0 5% 1/10W		R132	1-216-069-00	METAL GLAZE 6.8K 5% 1/10W	
JR9	1-216-296-00	METAL GLAZE 0 5% 1/8W		R133	1-216-061-00	METAL GLAZE 3.3K 5% 1/10W	
JR10	1-216-296-00	METAL GLAZE 0 5% 1/8W		R134	1-216-049-00	METAL GLAZE 1K 5% 1/10W	
JR11	1-216-296-00	METAL GLAZE 0 5% 1/8W		R135	1-216-198-00	METAL GLAZE 1K 5% 1/8W	
JR12	1-216-295-00	METAL GLAZE 0 5% 1/10W		R153	1-216-025-00	METAL GLAZE 100 5% 1/10W	
JR13	1-163-093-00	CERAMIC CHIP 10PF	5% 50V	R159	1-216-107-00	METAL GLAZE 270K 5% 1/10W	
				R160	1-216-049-00	METAL GLAZE 1K 5% 1/10W	
				R161	1-218-755-11	METAL CHIP 130K 0.50% 1/10W	
				R162	1-216-073-00	METAL GLAZE 10K 5% 1/10W	
				R163	1-216-113-00	METAL GLAZE 470K 5% 1/10W	
				R164	1-216-113-00	METAL GLAZE 470K 5% 1/10W	
				R165	1-216-081-00	METAL GLAZE 22K 5% 1/10W	
				R166	1-216-049-00	METAL GLAZE 1K 5% 1/10W	
				R167	1-216-073-00	METAL GLAZE 10K 5% 1/10W	
				R168	1-216-113-00	METAL GLAZE 470K 5% 1/10W	
				R169	1-216-049-00	METAL GLAZE 1K 5% 1/10W	
				R175	1-216-083-00	METAL GLAZE 27K 5% 1/10W	
				R176	1-216-075-00	METAL GLAZE 12K 5% 1/10W	
				R177	1-216-095-00	METAL GLAZE 82K 5% 1/10W	
				R178	1-216-059-00	METAL GLAZE 2.7K 5% 1/10W	
				R179	1-216-057-00	METAL GLAZE 2.2K 5% 1/10W	
				R181	1-216-037-00	METAL GLAZE 330 5% 1/10W	

IF (KV-S3412U)

VW

V

REF. NO.	PART NO.	DESCRIPTION	REMARK	REF. NO.	PART NO.	DESCRIPTION	REMARK
<VARIABLE RESISTOR>				Q1708	8-729-901-59	TRANSISTOR BF199	
RV1	1-241-121-11	RES, ADJ, CARBON 4.7K		Q1709	8-729-255-12	TRANSISTOR 2SC2551-0	
<TRANSFORMER>				<RESISTOR>			
T4	1-416-017-21	COIL		R1701	1-249-405-11	CARBON	100 5% 1/4W
T5	1-416-018-21	COIL		R1702	1-249-419-11	CARBON	1.5K 5% 1/4W
*****				R1703	1-249-405-11	CARBON	100 5% 1/4W
*A-1342-189-A	VM BOARD, COMPLETE	*****		R1704	1-249-418-11	CARBON	1.2K 5% 1/4W
4-382-854-11	SCREW (M3X10), P, SW (+)			R1705	1-247-736-11	CARBON	56 5% 1/2W F
<CAPACITOR>				R1706	1-249-414-11	CARBON	560 5% 1/4W F
C1701	1-124-119-00	ELECT	330MF 20% 16V	R1707	1-249-411-11	CARBON	330 5% 1/4W
C1702	1-102-951-00	CERAMIC	15PF 5% 50V	R1709	1-249-418-11	CARBON	1.2K 5% 1/4W
C1703	1-102-115-00	CERAMIC	560PF 10% 50V	R1710	1-249-385-11	CARBON	2.2 5% 1/4W F
C1704	1-161-830-00	CERAMIC	0.0047MF 500V	R1711	1-249-432-11	CARBON	18K 5% 1/4W
C1705	1-124-120-11	ELECT	220MF 20% 16V	R1712	1-249-435-11	CARBON	33K 5% 1/4W
C1706	1-123-935-00	ELECT	33MF 20% 160V	R1713	1-249-438-11	CARBON	56K 5% 1/4W
C1707	1-124-907-11	ELECT	10MF 20% 50V	R1714	1-249-429-11	CARBON	10K 5% 1/4W
C1708	1-101-006-00	CERAMIC	0.047MF 50V	R1715	1-216-476-11	METAL OXIDE	180 5% 3W F
C1709	1-108-704-11	MYLAR	0.1MF 10% 200V	R1716	1-249-417-11	CARBON	1K 5% 1/4W F
C1710	1-104-721-91	FILM	0.047MF 10% 250V	R1717	1-249-432-11	CARBON	18K 5% 1/4W
C1711	1-162-318-11	CERAMIC	0.001MF 10% 500V	R1718	1-249-412-11	CARBON	390 5% 1/4W
C1712	1-124-799-11	ELECT	2.2MF 20% 160V	R1719	1-249-419-11	CARBON	1.5K 5% 1/4W
C1713	1-162-318-11	CERAMIC	0.001MF 10% 500V	R1720	1-249-441-11	CARBON	100K 5% 1/4W
C1714	1-104-721-91	FILM	0.047MF 10% 250V	R1721	1-249-414-11	CARBON	560 5% 1/4W
C1716	1-124-907-11	ELECT	10MF 20% 50V	R1722	1-249-385-11	CARBON	2.2 5% 1/4W F
C1718	1-124-120-11	ELECT	220MF 20% 16V	R1723	1-249-429-11	CARBON	10K 5% 1/4W
C1719	1-124-907-11	ELECT	10MF 20% 50V	R1724	1-249-436-11	CARBON	39K 5% 1/4W
<CONNECTOR>				R1725	1-249-416-11	CARBON	820 5% 1/4W
CN1819*1-568-882-51	PIN, CONNECTOR 7P			R1726	1-249-414-11	CARBON	560 5% 1/4W
CN1830*1-568-878-51	PIN, CONNECTOR 3P			R1727	1-249-402-11	CARBON	56 5% 1/4W F
<DIODE>				R1729	1-216-451-11	METAL OXIDE	120 5% 2W F
D1701	8-719-911-19	DIODE 1SS119		R1731	1-249-420-11	CARBON	1.8K 5% 1/4W
D1702	8-719-911-19	DIODE 1SS119		R1732	1-249-426-11	CARBON	5.6K 5% 1/4W
D1703	8-719-911-19	DIODE 1SS119		R1734	1-249-419-11	CARBON	1.5K 5% 1/4W
D1704	8-719-982-37	DIODE MTZJ-39C		*****			
D1705	8-719-982-37	DIODE MTZJ-39C		*A-1347-069-A	V BOARD, COMPLETE	*****	
D1706	8-719-911-19	DIODE 1SS119		<CAPACITOR>			
D1707	8-719-911-19	DIODE 1SS119		C01	1-124-916-11	ELECT	22MF 20% 50V
<COIL>				C02	1-163-038-00	CERAMIC CHIP	0.1MF 25V
L1702	1-408-418-00	INDUCTOR	56UH	C03	1-163-038-00	CERAMIC CHIP	0.1MF 25V
<TRANSISTOR>				C04	1-124-916-11	ELECT	22MF 20% 50V
Q1701	8-729-119-78	TRANSISTOR 2SC2785-HFE		C05	1-163-037-11	CERAMIC CHIP	0.022MF 10% 25V
Q1702	8-729-173-38	TRANSISTOR 2SA733-K		C06	1-124-120-11	ELECT	220MF 20% 16V
Q1703	8-729-017-05	TRANSISTOR 2SA1837		C07	1-124-903-11	ELECT	1MF 20% 50V
Q1704	8-729-119-78	TRANSISTOR 2SC2785-HFE		C08	1-163-097-00	CERAMIC CHIP	15PF 5% 50V
Q1705	8-729-017-06	TRANSISTOR 2SC4793		C09	1-163-141-00	CERAMIC CHIP	0.001MF 5% 50V
Q1706	8-729-119-78	TRANSISTOR 2SC2785-HFE		C10	1-163-133-00	CERAMIC CHIP	470PF 5% 50V
Q1707	8-729-140-96	TRANSISTOR 2SD774-34		C11	1-163-037-11	CERAMIC CHIP	0.022MF 10% 25V
				C12	1-163-127-00	CERAMIC CHIP	270PF 5% 50V
				C13	1-163-117-00	CERAMIC CHIP	100PF 5% 50V
				C14	1-163-097-00	CERAMIC CHIP	15PF 5% 50V
				C15	1-163-103-00	CERAMIC CHIP	27PF 5% 50V
				C16	1-164-232-11	CERAMIC CHIP	0.01MF 10% 50V
				C17	1-163-809-11	CERAMIC CHIP	0.047MF 10% 25V
				C18	1-163-093-00	CERAMIC CHIP	10PF 5% 50V
				C19	1-163-089-00	CERAMIC CHIP	6PF 0.25PF 50V
				C20	1-163-125-00	CERAMIC CHIP	220PF 5% 50V
				C21	1-163-833-00	CERAMIC CHIP	0.068MF 25V
				C22	1-163-117-00	CERAMIC CHIP	100PF 5% 50V



REF. NO.	PART NO.	DESCRIPTION	REMARK	REF. NO.	PART NO.	DESCRIPTION	REMARK
C23	1-163-210-00	CERAMIC CHIP 0.0016MF	5%				
C24	1-164-505-11	CERAMIC CHIP 2.2MF					
C25	1-164-505-11	CERAMIC CHIP 2.2MF					
C26	1-163-809-11	CERAMIC CHIP 0.047MF	10%				
C28	1-163-137-00	CERAMIC CHIP 680PF	5%				
C30	1-136-171-00	FILM 0.33MF	5%				
C32	1-163-038-00	CERAMIC CHIP 0.1MF					
C33	1-124-910-11	ELECT 47MF	20%				
C34	1-124-907-11	ELECT 10MF	20%				
C35	1-163-243-11	CERAMIC CHIP 47PF	5%				
C36	1-163-239-11	CERAMIC CHIP 33PF	5%				
C37	1-216-295-00	METAL GLAZE 0	5%				1/10W
C39	1-163-135-00	CERAMIC CHIP 560PF	5%				
C40	1-163-263-11	CERAMIC CHIP 330PF	5%				
C53	1-163-038-00	CERAMIC CHIP 0.1MF					
C54	1-163-038-00	CERAMIC CHIP 0.1MF					25V
<CONNECTOR>							
CN1737*	1-564-511-11	PLUG, CONNECTOR 8P					
CN1741*	1-564-511-31	PLUG, CONNECTOR 8P					
<TRIMMER>							
CT01	1-141-418-11	CAP, ADJ					
<DIODE>							
D01	8-719-400-18	DIODE MA152WK					
D03	8-719-104-34	DIODE 1S2836					
D04	8-719-104-34	DIODE 1S2836					
D09	8-719-400-18	DIODE MA152WK					
D10	8-719-400-18	DIODE MA152WK					
D11	8-719-400-18	DIODE MA152WK					
D12	8-719-400-18	DIODE MA152WK					
<IC>							
IC01	8-759-166-41	IC SDA5248-2C1					
IC02	8-759-037-64	IC SDA5231-2					
IC03	8-759-035-39	IC MCM514256AP80					
IC04	8-752-353-39	IC CXD1050A-15P					
IC05	8-759-987-16	IC LM393P					
<COIL>							
L01	1-408-411-00	INDUCTOR 15UH					
L02	1-408-414-00	INDUCTOR 27UH					
L03	1-408-417-00	INDUCTOR 47UH					
L04	1-408-413-00	INDUCTOR 22UH					
L05	1-408-409-00	INDUCTOR 10UH					
<TRANSISTOR>							
Q01	8-729-901-81	TRANSISTOR 2SC2412K-T-146-R					
Q03	8-729-901-81	TRANSISTOR 2SC2412K-T-146-R					
Q04	8-729-901-81	TRANSISTOR 2SC2412K-T-146-R					
Q06	8-729-901-81	TRANSISTOR 2SC2412K-T-146-R					
Q07	8-729-901-81	TRANSISTOR 2SC2412K-T-146-R					
Q08	8-729-216-22	TRANSISTOR 2SA1162-G					
Q09	8-729-901-81	TRANSISTOR 2SC2412K-T-146-R					
Q10	8-729-901-81	TRANSISTOR 2SC2412K-T-146-R					
Q11	8-729-901-81	TRANSISTOR 2SC2412K-T-146-R					
Q12	8-729-901-00	TRANSISTOR DTC124EK					
<RESISTOR>							
JR02	1-216-295-00	METAL GLAZE 0	5%				1/10W
R01	1-216-025-00	METAL GLAZE 100	5%				1/10W
R02	1-216-025-00	METAL GLAZE 100	5%				1/10W
R03	1-216-055-00	METAL GLAZE 1.8K	5%				1/10W
R04	1-216-049-00	METAL GLAZE 1K	5%				1/10W
R05	1-216-041-00	METAL GLAZE 470	5%				1/10W
R06	1-216-029-00	METAL GLAZE 150	5%				1/10W
R07	1-216-041-00	METAL GLAZE 470	5%				1/10W
R08	1-216-071-00	METAL GLAZE 8.2K	5%				1/10W
R09	1-216-091-00	METAL GLAZE 56K	5%				1/10W
R10	1-216-057-00	METAL GLAZE 2.2K	5%				1/10W
R11	1-216-057-00	METAL GLAZE 2.2K	5%				1/10W
R12	1-216-057-00	METAL GLAZE 2.2K	5%				1/10W
R13	1-216-065-00	METAL GLAZE 4.7K	5%				1/10W
R15	1-216-061-00	METAL GLAZE 3.3K	5%				1/10W
R16	1-216-033-00	METAL GLAZE 220	5%				1/10W
R17	1-216-033-00	METAL GLAZE 220	5%				1/10W
R20	1-216-049-00	METAL GLAZE 1K	5%				1/10W
R21	1-216-049-00	METAL GLAZE 1K	5%				1/10W
R22	1-216-057-00	METAL GLAZE 2.2K	5%				1/10W
R23	1-216-065-00	METAL GLAZE 4.7K	5%				1/10W
R24	1-216-091-00	METAL GLAZE 56K	5%				1/10W
R25	1-216-065-00	METAL GLAZE 4.7K	5%				1/10W
R26	1-216-081-00	METAL GLAZE 22K	5%				1/10W
R27	1-216-043-00	METAL GLAZE 560	5%				1/10W
R28	1-216-043-00	METAL GLAZE 560	5%				1/10W
R29	1-216-043-00	METAL GLAZE 560	5%				1/10W
R30	1-216-037-00	METAL GLAZE 330	5%				1/10W
R31	1-216-061-00	METAL GLAZE 3.3K	5%				1/10W
R32	1-216-073-00	METAL GLAZE 10K	5%				1/10W
R33	1-216-017-00	METAL GLAZE 47	5%				1/10W
R34	1-216-081-00	METAL GLAZE 22K	5%				1/10W
R35	1-216-081-00	METAL GLAZE 22K	5%				1/10W
R36	1-216-057-00	METAL GLAZE 2.2K	5%				1/10W
R37	1-216-057-00	METAL GLAZE 2.2K	5%				1/10W
R38	1-218-773-11	METAL CHIP 750K	0.50%				1/10W
R39	1-218-758-11	METAL CHIP 180K	0.50%				1/10W
R40	1-216-043-00	METAL GLAZE 560	5%				1/10W
R41	1-216-033-00	METAL GLAZE 220	5%				1/10W
R42	1-216-033-00	METAL GLAZE 220	5%				1/10W
R43	1-216-033-00	METAL GLAZE 220	5%				1/10W
R44	1-216-033-00	METAL GLAZE 220	5%				1/10W
R46	1-216-073-00	METAL GLAZE 10K	5%				1/10W
R47	1-216-057-00	METAL GLAZE 2.2K	5%				1/10W
R48	1-216-071-00	METAL GLAZE 8.2K	5%				1/10W
R49	1-216-071-00	METAL GLAZE 8.2K	5%				1/10W
R50	1-216-071-00	METAL GLAZE 8.2K	5%				1/10W
R54	1-216-073-00	METAL GLAZE 10K	5%				1/10W
R55	1-216-069-00	METAL GLAZE 6.8K	5%				1/10W
<CRYSTAL>							
X02	1-567-495-11	OSCILLATOR, CRYSTAL					

	*1-643-004-21	H1 BOARD					

<CAPACITOR>							
C083	1-163-037-11	CERAMIC CHIP 0.022MF	10%				25V

REF. NO.	PART NO.	DESCRIPTION	REMARK	REF. NO.	PART NO.	DESCRIPTION	REMARK
R951	1-216-063-00	METAL GLAZE	3.9K 5% 1/10W			<CONNECTOR>	
R952	1-216-113-00	METAL GLAZE	470K 5% 1/10W				
R953	1-216-188-00	METAL GLAZE	390 5% 1/8W				
R954	1-216-039-00	METAL GLAZE	390 5% 1/10W				
R955	1-216-039-00	METAL GLAZE	390 5% 1/10W				
R956	1-216-089-00	METAL GLAZE	47K 5% 1/10W				
R957	1-216-039-00	METAL GLAZE	390 5% 1/10W				
R958	1-216-089-00	METAL GLAZE	47K 5% 1/10W				
R959	1-216-071-00	METAL GLAZE	8.2K 5% 1/10W				
R960	1-216-071-00	METAL GLAZE	8.2K 5% 1/10W				
R961	1-216-071-00	METAL GLAZE	8.2K 5% 1/10W				
R965	1-216-029-00	METAL GLAZE	150 5% 1/10W				
R966	1-216-029-00	METAL GLAZE	150 5% 1/10W				
R967	1-216-029-00	METAL GLAZE	150 5% 1/10W				
R968	1-216-055-00	METAL GLAZE	1.8K 5% 1/10W				
R969	1-216-055-00	METAL GLAZE	1.8K 5% 1/10W				
R970	1-216-055-00	METAL GLAZE	1.8K 5% 1/10W				
R971	1-216-055-00	METAL GLAZE	1.8K 5% 1/10W				
R972	1-216-055-00	METAL GLAZE	1.8K 5% 1/10W				
R973	1-216-055-00	METAL GLAZE	1.8K 5% 1/10W				
R974	1-216-055-00	METAL GLAZE	1.8K 5% 1/10W				
R975	1-216-055-00	METAL GLAZE	1.8K 5% 1/10W				
R976	1-216-055-00	METAL GLAZE	1.8K 5% 1/10W				
R977	1-216-055-00	METAL GLAZE	1.8K 5% 1/10W				

*A-1620-049-A		B BOARD, COMPLETE		*****			
<CAPACITOR>							
C1301	1-164-232-11	CERAMIC CHIP	0.01MF 10% 50V				
C1302	1-126-101-11	ELECT	100MF 20% 16V				
C1303	1-164-232-11	CERAMIC CHIP	0.01MF 10% 50V				
C1304	1-164-232-11	CERAMIC CHIP	0.01MF 10% 50V				
C1305	1-163-105-00	CERAMIC CHIP	33PF 5% 50V				
C1306	1-163-109-00	CERAMIC CHIP	47PF 5% 50V				
C1307	1-164-232-11	CERAMIC CHIP	0.01MF 10% 50V				
C1308	1-163-101-00	CERAMIC CHIP	22PF 5% 50V				
C1309	1-163-101-00	CERAMIC CHIP	22PF 5% 50V				
C1310	1-126-101-11	ELECT	100MF 20% 16V				
C1311	1-163-038-00	CERAMIC CHIP	0.1MF 25V				
C1312	1-163-133-00	CERAMIC CHIP	470PF 5% 50V				
C1313	1-124-917-11	ELECT	33MF 20% 50V				
C1314	1-126-101-11	ELECT	100MF 20% 16V				
C1315	1-164-232-11	CERAMIC CHIP	0.01MF 10% 50V				
C1316	1-126-101-11	ELECT	100MF 20% 16V				
C1317	1-164-232-11	CERAMIC CHIP	0.01MF 10% 50V				
C1318	1-124-910-11	ELECT	47MF 20% 50V				
C1319	1-164-232-11	CERAMIC CHIP	0.01MF 10% 50V				
C1320	1-163-141-00	CERAMIC CHIP	0.001MF 5% 50V				
C1321	1-164-232-11	CERAMIC CHIP	0.01MF 10% 50V				
C1322	1-164-232-11	CERAMIC CHIP	0.01MF 10% 50V				
C1323	1-164-232-11	CERAMIC CHIP	0.01MF 10% 50V				
C1324	1-126-101-11	ELECT	100MF 20% 16V				
C1325	1-164-232-11	CERAMIC CHIP	0.01MF 10% 50V				
C1326	1-164-232-11	CERAMIC CHIP	0.01MF 10% 50V				
C1327	1-164-232-11	CERAMIC CHIP	0.01MF 10% 50V				
C1328	1-164-232-11	CERAMIC CHIP	0.01MF 10% 50V				
C1329	1-163-038-00	CERAMIC CHIP	0.1MF 25V				
C1330	1-163-038-00	CERAMIC CHIP	0.1MF 25V				
C1331	1-164-232-11	CERAMIC CHIP	0.01MF 10% 50V				
C1332	1-164-232-11	CERAMIC CHIP	0.01MF 10% 50V				
C1333	1-164-232-11	CERAMIC CHIP	0.01MF 10% 50V				
						<CONNECTOR>	
				CN0302*	1-573-299-11	CONNECTOR, BOARD TO BOARD 10P	
						<DIODE>	
				D1301	8-719-400-18	DIODE MA152WK	
						<FILTER>	
				FL1301	1-239-550-41	FILTER, LOW PASS	
				FL1302	1-239-550-41	FILTER, LOW PASS	
				FL1303	1-239-550-41	FILTER, LOW PASS	
				FL1304	1-236-164-11	ENCAPSULATED COMPONENT	
						<IC>	
				IC1301	8-752-357-88	IC CXD2024Q-TL	
						<COIL>	
				L1301	1-408-405-00	INDUCTOR 4.7UH	
				L1302	1-408-403-00	INDUCTOR 3.3UH	
				L1303	1-408-405-00	INDUCTOR 4.7UH	
				L1304	1-408-405-00	INDUCTOR 4.7UH	
						<TRANSISTOR>	
				Q1301	8-729-216-22	TRANSISTOR 2SA1162-G	
				Q1302	8-729-216-22	TRANSISTOR 2SA1162-G	
				Q1303	8-729-216-22	TRANSISTOR 2SA1162-G	
				Q1304	8-729-901-81	TRANSISTOR 2SC2412K-T-146-R	
				Q1305	8-729-901-81	TRANSISTOR 2SC2412K-T-146-R	
				Q1306	8-729-901-81	TRANSISTOR 2SC2412K-T-146-R	
				Q1307	8-729-216-22	TRANSISTOR 2SA1162-G	
				Q1308	8-729-216-22	TRANSISTOR 2SA1162-G	
				Q1310	8-729-216-22	TRANSISTOR 2SA1162-G	
						<RESISTOR>	
				R1301	1-216-053-00	METAL GLAZE 1.5K 5% 1/10W	
				R1302	1-216-059-00	METAL GLAZE 2.7K 5% 1/10W	
				R1303	1-216-043-00	METAL GLAZE 560 5% 1/10W	
				R1304	1-216-043-00	METAL GLAZE 560 5% 1/10W	
				R1305	1-216-067-00	METAL GLAZE 5.6K 5% 1/10W	
				R1306	1-216-073-00	METAL GLAZE 10K 5% 1/10W	
				R1307	1-216-069-00	METAL GLAZE 6.8K 5% 1/10W	
				R1308	1-216-069-00	METAL GLAZE 6.8K 5% 1/10W	
				R1309	1-216-055-00	METAL GLAZE 1.8K 5% 1/10W	
				R1310	1-216-295-00	METAL GLAZE 0 5% 1/10W	
				R1311	1-216-073-00	METAL GLAZE 10K 5% 1/10W	
				R1312	1-216-057-00	METAL GLAZE 2.2K 5% 1/10W	
				R1313	1-216-089-00	METAL GLAZE 47K 5% 1/10W	
				R1314	1-216-065-00	METAL GLAZE 4.7K 5% 1/10W	
				R1315	1-216-049-00	METAL GLAZE 1K 5% 1/10W	
				R1316	1-216-071-00	METAL GLAZE 8.2K 5% 1/10W	
				R1317	1-216-083-00	METAL GLAZE 27K 5% 1/10W	
				R1318	1-216-051-00	METAL GLAZE 1.2K 5% 1/10W	
				R1319	1-216-043-00	METAL GLAZE 560 5% 1/10W	
				R1320	1-216-067-00	METAL GLAZE 5.6K 5% 1/10W	
				R1321	1-216-049-00	METAL GLAZE 1K 5% 1/10W	
				R1322	1-216-025-00	METAL GLAZE 100 5% 1/10W	
				R1324	1-216-055-00	METAL GLAZE 1.8K 5% 1/10W	

REF. NO.	PART NO.	DESCRIPTION	REMARK	REF. NO.	PART NO.	DESCRIPTION	REMARK
R1325	1-216-043-00	METAL GLAZE 560 5% 1/10W		C1448	1-164-222-11	CERAMIC CHIP 0.22MF	25V
R1326	1-216-067-00	METAL GLAZE 5.6K 5% 1/10W		C1449	1-163-257-11	CERAMIC CHIP 180PF	5% 50V
R1327	1-216-049-00	METAL GLAZE 1K 5% 1/10W		C1450	1-164-005-11	CERAMIC CHIP 0.47MF	25V
R1330	1-216-067-00	METAL GLAZE 5.6K 5% 1/10W		C1452	1-163-038-00	CERAMIC CHIP 0.1MF	25V
R1331	1-216-049-00	METAL GLAZE 1K 5% 1/10W		C1453	1-163-038-00	CERAMIC CHIP 0.1MF	25V
R1332	1-216-653-11	METAL CHIP 1.2K 0.50% 1/10W		C1454	1-163-038-00	CERAMIC CHIP 0.1MF	25V
R1333	1-216-666-11	METAL CHIP 4.3K 0.50% 1/10W		C1455	1-163-133-00	CERAMIC CHIP 470PF	5% 50V
R1334	1-216-635-11	METAL CHIP 220 0.50% 1/10W		C1456	1-163-133-00	CERAMIC CHIP 470PF	5% 50V
R1335	1-216-637-11	METAL CHIP 270 0.50% 1/10W		C1457	1-164-005-11	CERAMIC CHIP 0.47MF	25V
R1336	1-216-657-11	METAL CHIP 1.8K 0.50% 1/10W		C1460	1-163-038-00	CERAMIC CHIP 0.1MF	25V
R1337	1-216-663-11	METAL CHIP 3.3K 0.50% 1/10W		C1461	1-164-005-11	CERAMIC CHIP 0.47MF	25V
R1338	1-216-657-11	METAL CHIP 1.8K 0.50% 1/10W		C1462	1-164-005-11	CERAMIC CHIP 0.47MF	25V
R1339	1-216-295-00	METAL GLAZE 0 5% 1/10W		C1463	1-126-101-11	ELECT 100NF	20% 16V
R1342	1-216-295-00	METAL GLAZE 0 5% 1/10W		C1464	1-126-101-11	ELECT 100NF	20% 16V
R1343	1-216-035-00	METAL GLAZE 270 5% 1/10W		C1465	1-126-101-11	ELECT 100NF	20% 16V

*A-1622-005-A P BOARD, COMPLETE							

<CAPACITOR>							
C1401	1-163-038-00	CERAMIC CHIP 0.1MF	25V	C1472	1-164-004-11	CERAMIC CHIP 0.1MF	10% 25V
C1402	1-163-038-00	CERAMIC CHIP 0.1MF	25V	C1473	1-164-004-11	CERAMIC CHIP 0.1MF	10% 25V
C1403	1-163-017-00	CERAMIC CHIP 0.0047MF	10% 50V	C1481	1-216-295-00	METAL GLAZE 0	5% 1/10W
C1404	1-163-037-11	CERAMIC CHIP 0.022MF	10% 25V	C1482	1-163-001-11	CERAMIC CHIP 220PF	10% 50V
C1405	1-163-097-00	CERAMIC CHIP 15PF	5% 50V	C1491	1-124-907-11	ELECT 10NF	20% 50V
C1406	1-163-097-00	CERAMIC CHIP 15PF	5% 50V	<CONNECTOR>			
C1407	1-163-038-00	CERAMIC CHIP 0.1MF	25V	CN1514*	1-568-879-51	PIN, CONNECTOR 4P	
C1408	1-163-017-00	CERAMIC CHIP 0.0047MF	10% 50V	CN1515*	1-564-516-11	PLUG, CONNECTOR 13P	
C1409	1-124-903-11	ELECT 1MF	20% 50V	CN1516*	1-568-879-11	PIN, CONNECTOR 4P	
C1410	1-163-038-00	CERAMIC CHIP 0.1MF	25V	CN1538*	1-573-299-11	CONNECTOR, BOARD TO BOARD 10P	
C1412	1-163-038-00	CERAMIC CHIP 0.1MF	25V	<DIODE>			
C1414	1-163-121-00	CERAMIC CHIP 150PF	5% 50V	D1401	8-719-401-41	DIODE MA3051L-TX	
C1416	1-163-129-00	CERAMIC CHIP 330PF	5% 50V	<FILTER>			
C1417	1-163-129-00	CERAMIC CHIP 330PF	5% 50V	FL1403	1-236-071-11	ENCAPSULATED COMPONENT	
C1419	1-164-005-11	CERAMIC CHIP 0.47MF	25V	FL1404	1-236-071-11	ENCAPSULATED COMPONENT	
C1420	1-163-038-00	CERAMIC CHIP 0.1MF	25V	FL1405	1-236-071-11	ENCAPSULATED COMPONENT	
C1421	1-163-038-00	CERAMIC CHIP 0.1MF	25V	FL1406	1-236-071-11	ENCAPSULATED COMPONENT	
C1422	1-163-038-00	CERAMIC CHIP 0.1MF	25V	FL1407	1-236-071-11	ENCAPSULATED COMPONENT	
C1423	1-163-038-00	CERAMIC CHIP 0.1MF	25V	FL1408	1-236-071-11	ENCAPSULATED COMPONENT	
C1424	1-163-009-11	CERAMIC CHIP 0.001MF	10% 50V	<IC>			
C1425	1-163-009-11	CERAMIC CHIP 0.001MF	10% 50V	IC1401	8-759-073-16	IC TDA9160/N2	
C1427	1-124-916-11	ELECT 22MF	20% 50V	IC1402	8-759-086-97	IC TDA4661T/V2	
C1428	1-163-038-00	CERAMIC CHIP 0.1MF	25V	IC1403	8-759-055-51	IC SDA9087XGEG	
C1429	1-163-113-00	CERAMIC CHIP 68PF	5% 50V	IC1404	8-759-055-52	IC SDA9089XGEG	
C1430	1-163-038-00	CERAMIC CHIP 0.1MF	25V	IC1405	8-759-046-27	IC SDA9086-3	
C1431	1-163-031-11	CERAMIC CHIP 0.01MF	50V	IC1406	8-759-504-21	IC TDA8443A/C4	
C1432	1-163-031-11	CERAMIC CHIP 0.01MF	50V	IC1410	8-759-037-45	IC MC78L08ACPRP	
C1433	1-163-031-11	CERAMIC CHIP 0.01MF	50V	IC1411	8-759-081-30	IC MC78L05ACPRP	
C1434	1-163-038-00	CERAMIC CHIP 0.1MF	25V	<COIL>			
C1435	1-163-038-00	CERAMIC CHIP 0.1MF	25V	L1401	1-408-418-00	INDUCTOR 56UH	
C1436	1-163-038-00	CERAMIC CHIP 0.1MF	25V	L1405	1-408-407-00	INDUCTOR 6.8UH	
C1437	1-164-343-11	CERAMIC CHIP 0.056MF	10% 25V	L1406	1-408-407-00	INDUCTOR 6.8UH	
C1438	1-163-139-00	CERAMIC CHIP 820PF	10% 50V	<TRANSISTOR>			
C1439	1-163-038-00	CERAMIC CHIP 0.1MF	25V	Q1401	8-729-901-81	TRANSISTOR 2SC2412K-T-146-R	
C1440	1-163-038-00	CERAMIC CHIP 0.1MF	25V				
C1441	1-164-005-11	CERAMIC CHIP 0.47MF	25V				
C1442	1-164-005-11	CERAMIC CHIP 0.47MF	25V				
C1443	1-163-251-11	CERAMIC CHIP 100PF	5% 50V				
C1444	1-164-005-11	CERAMIC CHIP 0.47MF	25V				
C1445	1-164-005-11	CERAMIC CHIP 0.47MF	25V				
C1446	1-164-005-11	CERAMIC CHIP 0.47MF	25V				
C1447	1-163-038-00	CERAMIC CHIP 0.1MF	25V				

H1	H2	J
----	----	---

REF. NO.	PART NO.	DESCRIPTION	REMARK	REF. NO.	PART NO.	DESCRIPTION	REMARK
C087	1-163-037-11	CERAMIC CHIP 0.022MF	10% 25V	C291	1-101-005-00	CERAMIC 0.022MF	50V
		<CONNECTOR>		C292	1-101-005-00	CERAMIC 0.022MF	50V
CN1008*	1-564-516-11	PLUG, CONNECTOR 13P		C293	1-101-003-00	CERAMIC 0.0047MF	50V
		<JACK>		C294	1-101-003-00	CERAMIC 0.0047MF	50V
J81	1-568-678-11	TERMINAL BLOCK, S 3P		C295	1-163-009-11	CERAMIC CHIP 0.001MF	10% 50V
J82	1-562-837-11	JACK		C296	1-163-009-11	CERAMIC CHIP 0.001MF	10% 50V
		<COIL>		C901	1-163-017-00	CERAMIC CHIP 0.0047MF	10% 50V
L081	1-408-409-00	INDUCTOR 10UH		C902	1-163-017-00	CERAMIC CHIP 0.0047MF	10% 50V
L082	1-408-409-00	INDUCTOR 10UH		C904	1-163-133-00	CERAMIC CHIP 470PF	5% 50V
		<RESISTOR>		C905	1-163-133-00	CERAMIC CHIP 470PF	5% 50V
JR021	1-216-295-00	METAL GLAZE 0 5% 1/10W		C906	1-101-004-00	CERAMIC 0.01MF	50V
R081	1-216-073-00	METAL GLAZE 10K 5% 1/10W		C907	1-163-133-00	CERAMIC CHIP 470PF	5% 50V
R082	1-216-065-00	METAL GLAZE 4.7K 5% 1/10W		C908	1-163-133-00	CERAMIC CHIP 470PF	5% 50V
R083	1-216-057-00	METAL GLAZE 2.2K 5% 1/10W		C909	1-101-004-00	CERAMIC 0.01MF	50V
R084	1-216-202-00	METAL GLAZE 1.5K 5% 1/8W		C910	1-163-017-00	CERAMIC CHIP 0.0047MF	10% 50V
R085	1-216-202-00	METAL GLAZE 1.5K 5% 1/8W		C911	1-163-017-00	CERAMIC CHIP 0.0047MF	10% 50V
		<SWITCH>		C912	1-163-133-00	CERAMIC CHIP 470PF	5% 50V
S081	1-571-532-21	SWITCH, TACTIL		C913	1-163-133-00	CERAMIC CHIP 470PF	5% 50V
S082	1-571-532-21	SWITCH, TACTIL		C914	1-163-121-00	CERAMIC CHIP 150PF	5% 50V
S083	1-571-532-21	SWITCH, TACTIL		C915	1-163-121-00	CERAMIC CHIP 150PF	5% 50V
		*****		C916	1-163-017-00	CERAMIC CHIP 0.0047MF	10% 50V
	*1-642-997-11	H2 BOARD		C917	1-163-017-00	CERAMIC CHIP 0.0047MF	10% 50V
		*****		C918	1-163-133-00	CERAMIC CHIP 470PF	5% 50V
	*4-201-076-01	HOLDER, LED		C919	1-163-133-00	CERAMIC CHIP 470PF	5% 50V
	*4-374-987-01	GUIDE, LIGHT		C920	1-163-017-00	CERAMIC CHIP 0.0047MF	10% 50V
	4-381-686-01	BRACKET (B), LIGHT GUIDE		C921	1-163-017-00	CERAMIC CHIP 0.0047MF	10% 50V
		<CONNECTOR>		C922	1-124-477-11	ELECT 47MF	20% 16V
CN1132*	1-568-882-51	PIN, CONNECTOR 7P		C923	1-164-346-11	CERAMIC CHIP 1MF	16V
		<DIODE>		C924	1-124-477-11	ELECT 47MF	20% 16V
D092	8-719-948-31	DIODE LD-201VR		C925	1-124-477-11	ELECT 47MF	20% 16V
D093	8-719-948-31	DIODE LD-201VR		C926	1-164-346-11	CERAMIC CHIP 1MF	16V
D094	8-719-948-31	DIODE LD-201VR		C927	1-124-477-11	ELECT 47MF	20% 16V
		<IC>		C928	1-124-477-11	ELECT 47MF	20% 16V
IC091	8-741-101-75	IC SBX1610-11		C929	1-124-477-11	ELECT 47MF	20% 16V
		<RESISTOR>		C930	1-124-477-11	ELECT 47MF	20% 16V
R091	1-249-413-11	CARBON 470 5% 1/4W		C931	1-164-346-11	CERAMIC CHIP 1MF	16V
		*****		C932	1-164-346-11	CERAMIC CHIP 1MF	16V
	*A-1388-145-A	J BOARD, COMPLETE		C933	1-124-477-11	ELECT 47MF	20% 16V
		*****		C934	1-124-477-11	ELECT 47MF	20% 16V
		<CAPACITOR>		C935	1-124-477-11	ELECT 47MF	20% 16V
C281	1-126-103-11	ELECT 470MF 20% 16V		C936	1-164-346-11	CERAMIC CHIP 1MF	16V
				C937	1-164-346-11	CERAMIC CHIP 1MF	16V
				C938	1-124-477-11	ELECT 47MF	20% 16V
						<CONNECTOR>	
				CN1209	1-695-302-11	CONNECTOR, BOARD TO BOARD 50P	
				CN1210*	1-564-522-11	PLUG, CONNECTOR 7P	
				CN1233*	1-564-518-11	PLUG, CONNECTOR 3P	
				CN1240*	1-564-518-11	PLUG, CONNECTOR 3P	
						<DIODE>	
				D901	8-719-921-69	DIODE MTZJ-9.1	
				D902	8-719-921-69	DIODE MTZJ-9.1	
				D903	8-719-921-69	DIODE MTZJ-9.1	
				D904	8-719-921-69	DIODE MTZJ-9.1	
				D905	8-719-921-69	DIODE MTZJ-9.1	
				D906	8-719-921-69	DIODE MTZJ-9.1	
				D907	8-719-921-69	DIODE MTZJ-9.1	
				D908	8-719-921-69	DIODE MTZJ-9.1	
				D909	8-719-921-69	DIODE MTZJ-9.1	
				D910	8-719-921-69	DIODE MTZJ-9.1	

The components identified by shading and mark **▲** are critical for safety. Replace only with part number specified.

Les composants identifiés par une trame et une marque **▲** sont critiques pour la sécurité. Ne les remplacer que par une pièce portant le numéro spécifié.

P F2

REF. NO.	PART NO.	DESCRIPTION	REMARK	REF. NO.	PART NO.	DESCRIPTION	REMARK
Q1402	8-729-901-81	TRANSISTOR 2SC2412K-T-146-R		R1449	1-216-033-00	METAL GLAZE 220 5%	1/10W
Q1403	8-729-901-81	TRANSISTOR 2SC2412K-T-146-R		R1450	1-216-033-00	METAL GLAZE 220 5%	1/10W
Q1404	8-729-216-22	TRANSISTOR 2SA1162-G		R1451	1-216-073-00	METAL GLAZE 10K 5%	1/10W
Q1405	8-729-901-81	TRANSISTOR 2SC2412K-T-146-R		R1453	1-216-025-00	METAL GLAZE 100 5%	1/10W
Q1406	8-729-901-81	TRANSISTOR 2SC2412K-T-146-R		R1454	1-216-025-00	METAL GLAZE 100 5%	1/10W
Q1407	8-729-216-22	TRANSISTOR 2SA1162-G		R1455	1-216-081-00	METAL GLAZE 22K 5%	1/10W
Q1408	8-729-216-22	TRANSISTOR 2SA1162-G		R1456	1-216-081-00	METAL GLAZE 22K 5%	1/10W
Q1409	8-729-216-22	TRANSISTOR 2SA1162-G		R1458	1-216-041-00	METAL GLAZE 470 5%	1/10W
Q1413	8-729-216-22	TRANSISTOR 2SA1162-G		R1461	1-216-059-00	METAL GLAZE 2.7K 5%	1/10W
Q1414	8-729-900-53	TRANSISTOR DTC114EK		R1462	1-216-059-00	METAL GLAZE 2.7K 5%	1/10W
Q1415	8-729-901-81	TRANSISTOR 2SC2412K-T-146-R		R1463	1-216-049-00	METAL GLAZE 1K 5%	1/10W
Q1416	8-729-901-81	TRANSISTOR 2SC2412K-T-146-R		R1465	1-216-198-00	METAL GLAZE 1K 5%	1/8W
Q1417	8-729-900-53	TRANSISTOR DTC114EK		R1471	1-216-037-00	METAL GLAZE 330 5%	1/10W
Q1418	8-729-900-53	TRANSISTOR DTC114EK		R1484	1-216-295-00	METAL GLAZE 0 5%	1/10W
Q1419	8-729-900-53	TRANSISTOR DTC114EK		R1485	1-216-041-00	METAL GLAZE 470 5%	1/10W
Q1421	8-729-901-81	TRANSISTOR 2SC2412K-T-146-R		R1486	1-216-033-00	METAL GLAZE 220 5%	1/10W
Q1422	8-729-901-81	TRANSISTOR 2SC2412K-T-146-R		R1487	1-216-065-00	METAL GLAZE 4.7K 5%	1/10W
Q1423	8-729-901-00	TRANSISTOR DTC124EK		R1488	1-216-025-00	METAL GLAZE 100 5%	1/10W
Q1424	8-729-901-81	TRANSISTOR 2SC2412K-T-146-R		R1492	1-216-033-00	METAL GLAZE 220 5%	1/10W
<RESISTOR>				R1493	1-216-073-00	METAL GLAZE 10K 5%	1/10W
JR1401	1-216-295-00	METAL GLAZE 0 5%	1/10W	R1494	1-216-174-00	METAL GLAZE 100 5%	1/8W
JR1402	1-216-295-00	METAL GLAZE 0 5%	1/10W	R1495	1-216-053-00	METAL GLAZE 1.5K 5%	1/10W
JR1403	1-216-295-00	METAL GLAZE 0 5%	1/10W	R1496	1-216-065-00	METAL GLAZE 4.7K 5%	1/10W
JR1405	1-216-295-00	METAL GLAZE 0 5%	1/10W	R1497	1-216-041-00	METAL GLAZE 470 5%	1/10W
R1401	1-216-097-00	METAL GLAZE 100K 5%	1/10W	R1498	1-216-069-00	METAL GLAZE 6.8K 5%	1/10W
R1402	1-216-073-00	METAL GLAZE 10K 5%	1/10W	R1499	1-216-049-00	METAL GLAZE 1K 5%	1/10W
R1403	1-216-025-00	METAL GLAZE 100 5%	1/10W	<CRYSTAL>			
R1404	1-216-025-00	METAL GLAZE 100 5%	1/10W	X1401	1-567-505-11	OSCILLATOR, CRYSTAL	
R1405	1-216-049-00	METAL GLAZE 1K 5%	1/10W	X1402	1-567-504-11	OSCILLATOR, CRYSTAL	
R1406	1-216-051-00	METAL GLAZE 1.2K 5%	1/10W	*****			
R1407	1-216-057-00	METAL GLAZE 2.2K 5%	1/10W	*A-1624-017-A F2 BOARD, COMPLETE			
R1408	1-216-041-00	METAL GLAZE 470 5%	1/10W	*****			
R1410	1-216-029-00	METAL GLAZE 150 5%	1/10W	<CAPACITOR>			
R1411	1-216-041-00	METAL GLAZE 470 5%	1/10W	C661 ▲	1-136-519-11	FILM 0.47MF	20% 300V
R1412	1-216-041-00	METAL GLAZE 470 5%	1/10W	C662 ▲	1-136-518-11	FILM 0.33MF	20% 300V
R1413	1-216-041-00	METAL GLAZE 470 5%	1/10W	C664 ▲	1-164-246-61	CERAMIC 0.0022MF	20% 400V
R1414	1-216-041-00	METAL GLAZE 470 5%	1/10W	C666	1-124-120-11	ELECT 220MF	20% 25V
R1415	1-216-041-00	METAL GLAZE 470 5%	1/10W	C667	1-126-233-11	ELECT 22MF	20% 50V
R1417	1-216-033-00	METAL GLAZE 220 5%	1/10W	C672 ▲	1-161-964-91	CERAMIC 0.0047MF	250V
R1419	1-216-027-00	METAL GLAZE 120 5%	1/10W	C673 ▲	1-161-964-91	CERAMIC 0.0047MF	250V
R1421	1-216-033-00	METAL GLAZE 220 5%	1/10W	C674	1-125-555-11	ELECT 330MF	20% 400V
R1422	1-216-023-00	METAL GLAZE 82 5%	1/10W	C675	1-136-527-12	FILM 0.47MF	20% 300V
R1424	1-216-041-00	METAL GLAZE 470 5%	1/10W	<CONNECTOR>			
R1425	1-216-041-00	METAL GLAZE 470 5%	1/10W	CN0005	*1-508-765-00	PIN, CONNECTOR (5MM PITCH) 3P	
R1426	1-216-041-00	METAL GLAZE 470 5%	1/10W	CN0006	*1-508-765-00	PIN, CONNECTOR (5MM PITCH) 3P	
R1427	1-216-041-00	METAL GLAZE 470 5%	1/10W	CN0007	*1-508-786-00	PIN, CONNECTOR (5MM PITCH) 2P	
R1429	1-216-091-00	METAL GLAZE 56K 5%	1/10W	CN0924	*1-568-878-51	PIN, CONNECTOR 3P	
R1431	1-216-029-00	METAL GLAZE 150 5%	1/10W	CN0925	*1-695-294-11	PIN, CONNECTOR (PC BOARD) 6P	
R1432	1-216-031-00	METAL GLAZE 180 5%	1/10W	CN0929	*1-508-784-00	PIN, CONNECTOR (5MM PITCH) 1P	
R1433	1-216-113-00	METAL GLAZE 470K 5%	1/10W	CN0931▲	*1-691-291-11	PIN, CONNECTOR (PC BOARD) 5P	
R1434	1-216-023-00	METAL GLAZE 82 5%	1/10W	<DIODE>			
R1435	1-216-075-00	METAL GLAZE 12K 5%	1/10W	D661	8-719-911-19	DIODE 1SS119	
R1436	1-216-045-00	METAL GLAZE 680 5%	1/10W	D662	8-719-400-18	DIODE MA152WK	
R1437	1-216-033-00	METAL GLAZE 220 5%	1/10W	D663	8-719-510-63	DIODE D4S860L-F	
R1438	1-216-047-00	METAL GLAZE 820 5%	1/10W	D664	8-719-921-69	DIODE NTZJ-9.1	
R1439	1-216-057-00	METAL GLAZE 2.2K 5%	1/10W				
R1441	1-216-053-00	METAL GLAZE 1.5K 5%	1/10W				
R1442	1-216-053-00	METAL GLAZE 1.5K 5%	1/10W				
R1443	1-216-053-00	METAL GLAZE 1.5K 5%	1/10W				
R1444	1-216-041-00	METAL GLAZE 470 5%	1/10W				
R1445	1-216-083-00	METAL GLAZE 27K 5%	1/10W				
R1446	1-216-079-00	METAL GLAZE 18K 5%	1/10W				

Les composants identifiés par une trame et une marque Δ sont critiques pour la sécurité. Ne les remplacer que par une pièce portant le numéro spécifique.

The components identified by shading and mark Δ are critical for safety. Replace only with part number specified.

REF. NO.	PART NO.	DESCRIPTION	REMARK	REF. NO.	PART NO.	DESCRIPTION	REMARK
<TRANSFORMER>							
LF661A	1-424-436-11	TRANSFORMER, LINE FILTER		C512	1-126-103-11	ELECT 470MF	20% 16V
LF662A	1-424-436-11	TRANSFORMER, LINE FILTER		C514	1-163-105-00	CERAMIC CHIP 33PF	5% 50V
LF663A	1-421-862-11	LFT		C519	1-164-161-11	CERAMIC CHIP 0.0022MF	10% 50V
<TRANSISTOR>							
Q661	8-729-901-81	TRANSISTOR 2SC2412K-T-146-R		C522	1-163-141-00	CERAMIC CHIP 0.001MF	5% 50V
<RESISTOR>							
R663	Δ 1-244-945-91	CARBON 1M	5% 1/2W	C523	1-163-141-00	CERAMIC CHIP 0.001MF	5% 50V
R664	Δ 1-205-998-11	WIREWOUND 1	5% 10W	C531	1-164-493-11	CERAMIC CHIP 0.047MF	10% 50V
R665	Δ 1-218-265-91	METAL GLAZE 8.2M	5% 1W	C532	1-164-489-11	CERAMIC CHIP 0.22MF	10% 16V
R666	1-249-405-11	CARBON 100	5% 1/4W F	C538	1-164-489-11	CERAMIC CHIP 0.22MF	10% 16V
R667	1-249-430-11	CARBON 12K	5% 1/4W	C541	1-164-232-11	CERAMIC CHIP 0.01MF	10% 50V
R668	1-249-434-11	CARBON 27K	5% 1/4W	C542	1-163-037-11	CERAMIC CHIP 0.022MF	10% 25V
R669	Δ 1-202-968-11	WIREWOUND 1.2	5% 10W	C543	1-164-161-11	CERAMIC CHIP 0.0022MF	10% 50V
R670	Δ 1-205-998-11	WIREWOUND 1	5% 10W	C544	1-164-161-11	CERAMIC CHIP 0.0022MF	10% 50V
R671	1-249-415-11	CARBON 680	5% 1/4W F	C546	1-164-004-11	CERAMIC CHIP 0.1MF	10% 25V
<RELAY>							
RY661A	1-515-720-31	RELAY		C547	1-163-020-00	CERAMIC CHIP 0.0082MF	10% 50V
<THERMISTOR>							
TRP661A	1-809-827-11	THERMISTOR, POSITIVE		C549	1-163-989-11	CERAMIC CHIP 0.033MF	10% 25V
*****				C550	1-163-141-00	CERAMIC CHIP 0.001MF	5% 50V
*A-1635-001-A M BOARD, COMPLETE				C552	1-163-037-11	CERAMIC CHIP 0.022MF	10% 25V
*****				C559	1-164-004-11	CERAMIC CHIP 0.1MF	10% 25V
<CAPACITOR>				C560	1-164-161-11	CERAMIC CHIP 0.0022MF	10% 50V
C001	1-163-117-00	CERAMIC CHIP 100PF	5% 50V	C562	1-216-295-00	METAL GLAZE 0	5% 1/10W
C003	1-163-117-00	CERAMIC CHIP 100PF	5% 50V	C563	1-163-031-11	CERAMIC CHIP 0.01MF	50V
C007	1-163-117-00	CERAMIC CHIP 100PF	5% 50V	C564	1-163-031-11	CERAMIC CHIP 0.01MF	50V
C008	1-163-117-00	CERAMIC CHIP 100PF	5% 50V	C565	1-163-031-11	CERAMIC CHIP 0.01MF	50V
C010	1-163-117-00	CERAMIC CHIP 100PF	5% 50V	C566	1-163-031-11	CERAMIC CHIP 0.01MF	50V
C011	1-163-117-00	CERAMIC CHIP 100PF	5% 50V	C567	1-163-009-11	CERAMIC CHIP 0.001MF	10% 50V
C012	1-163-117-00	CERAMIC CHIP 100PF	5% 50V	C568	1-163-009-11	CERAMIC CHIP 0.001MF	10% 50V
C014	1-163-117-00	CERAMIC CHIP 100PF	5% 50V	C569	1-164-161-11	CERAMIC CHIP 0.0022MF	10% 50V
C016	1-163-141-00	CERAMIC CHIP 0.001MF	5% 50V	C570	1-162-568-11	CERAMIC CHIP 0.33MF	10% 16V
C018	1-164-505-11	CERAMIC CHIP 2.2MF	16V	<FILTER>			
C019	1-124-477-11	ELECT 47MF	20% 16V	CD001	1-577-364-11	VIBRATOR, CERAMIC	
C032	1-163-117-00	CERAMIC CHIP 100PF	5% 50V	<CONNECTOR>			
C035	1-163-037-11	CERAMIC CHIP 0.022MF	10% 25V	CN1406	*1-568-880-51	PIN, CONNECTOR 5P	
C036	1-164-005-11	CERAMIC CHIP 0.47MF	25V	CN1413	1-695-301-11	CONNECTOR, BOARD TO BOARD 40P	
C037	1-163-117-00	CERAMIC CHIP 100PF	5% 50V	CN1426	*1-568-881-51	PIN, CONNECTOR 6P	
C501	1-163-020-00	CERAMIC CHIP 0.0082MF	10% 50V	CN1432	*1-568-882-51	PIN, CONNECTOR 7P	
C502	1-164-232-11	CERAMIC CHIP 0.01MF	10% 50V	CN1441	*1-564-511-31	PLUG, CONNECTOR 8P	
C503	1-104-825-91	FILM 0.0047MF	5% 50V	<DIODE>			
C504	1-130-831-21	MYLAR 0.56MF	10% 63V	D001	8-719-027-82	DIODE MA3039H-TX	
C505	1-124-925-11	ELECT 2.2MF	20% 50V	D501	8-719-800-76	DIODE 1SS226	
C506	1-162-568-11	CERAMIC CHIP 0.33MF	10% 16V	D503	8-719-401-31	DIODE MA3047L-TX	
C507	1-164-489-11	CERAMIC CHIP 0.22MF	10% 16V	D504	8-719-400-18	DIODE MA152WK	
C508	1-164-232-11	CERAMIC CHIP 0.01MF	10% 50V	D510	8-719-105-91	DIODE RD5.6M-B2	
C509	1-164-161-11	CERAMIC CHIP 0.0022MF	10% 50V	<IC>			
C510	1-124-925-11	ELECT 2.2MF	20% 50V	IC001	8-759-072-93	IC SDA30C162	
C511	1-106-375-12	MYLAR 0.022MF	10% 250V		*1-540-123-11	SOCKET, IC 68P; IC001	
				IC003	8-759-160-87	IC M27C512-20B1-AE27	
				IC501	8-759-513-48	IC TDA2595/V9	
				IC561	8-752-347-92	IC CXD2018Q	
				IC562	8-759-998-98	IC LM358D	
				IC563	8-759-081-30	IC MC78L05ACPRP	
<COIL>							
				L001	1-408-421-00	INDUCTOR 100UH	
				L501	1-410-119-11	INDUCTOR 1MHM	
				L561	1-408-409-00	INDUCTOR 10UH	



REF. NO.	PART NO.	DESCRIPTION	REMARK	REF. NO.	PART NO.	DESCRIPTION	REMARK
L562	1-408-409-00	INDUCTOR	10UH	R510	1-216-073-00	METAL GLAZE	10K 5% 1/10W
L563	1-408-947-00	INDUCTOR	2.2MMH	R511	1-216-097-00	METAL GLAZE	100K 5% 1/10W
<TRANSISTOR>				R512	1-216-049-00	METAL GLAZE	1K 5% 1/10W
Q002	8-729-216-22	TRANSISTOR	2SA1162-G	R513	1-216-230-00	METAL GLAZE	22K 5% 1/8W
Q003	8-729-901-81	TRANSISTOR	2SC2412K-T-146-R	R514	1-216-061-00	METAL GLAZE	3.3K 5% 1/10W
Q501	8-729-901-01	TRANSISTOR	DTC144EK	R515	1-216-049-00	METAL GLAZE	1K 5% 1/10W
Q502	8-729-901-81	TRANSISTOR	2SC2412K-T-146-R	R516	1-216-039-00	METAL GLAZE	390 5% 1/10W
Q503	8-729-901-01	TRANSISTOR	DTC144EK	R517	1-216-039-00	METAL GLAZE	390 5% 1/10W
Q508	8-729-901-01	TRANSISTOR	DTC144EK	R518	1-216-075-00	METAL GLAZE	12K 5% 1/10W
Q509	8-729-901-81	TRANSISTOR	2SC2412K-T-146-R	R519	1-216-033-00	METAL GLAZE	220 5% 1/10W
Q564	8-729-216-22	TRANSISTOR	2SA1162-G	R520	1-216-093-00	METAL GLAZE	68K 5% 1/10W
Q565	8-729-901-81	TRANSISTOR	2SC2412K-T-146-R	R521	1-216-053-00	METAL GLAZE	1.5K 5% 1/10W
Q566	8-729-901-81	TRANSISTOR	2SC2412K-T-146-R	R522	1-216-085-00	METAL GLAZE	33K 5% 1/10W
Q567	8-729-901-01	TRANSISTOR	DTC144EK	R523	1-216-065-00	METAL GLAZE	4.7K 5% 1/10W
<RESISTOR>				R524	1-216-063-00	METAL GLAZE	3.9K 5% 1/10W
JR540	1-216-295-00	METAL GLAZE	0 5% 1/10W	R525	1-216-093-00	METAL GLAZE	68K 5% 1/10W
R001	1-216-025-00	METAL GLAZE	100 5% 1/10W	R526	1-216-073-00	METAL GLAZE	10K 5% 1/10W
R002	1-216-025-00	METAL GLAZE	100 5% 1/10W	R527	1-216-689-11	METAL GLAZE	39K 5% 1/10W
R003	1-216-049-00	METAL GLAZE	1K 5% 1/10W	R528	1-216-049-00	METAL GLAZE	1K 5% 1/10W
R006	1-216-049-00	METAL GLAZE	1K 5% 1/10W	R529	1-216-696-11	METAL CHIP	75K 0.50% 1/10W
R007	1-216-073-00	METAL GLAZE	10K 5% 1/10W	R531	1-216-085-00	METAL GLAZE	33K 5% 1/10W
R008	1-216-049-00	METAL GLAZE	1K 5% 1/10W	R532	1-216-671-11	METAL CHIP	6.8K 0.50% 1/10W
R010	1-216-049-00	METAL GLAZE	1K 5% 1/10W	R533	1-216-105-00	METAL GLAZE	220K 5% 1/10W
R011	1-216-049-00	METAL GLAZE	1K 5% 1/10W	R535	1-216-057-00	METAL GLAZE	2.2K 5% 1/10W
R012	1-216-049-00	METAL GLAZE	1K 5% 1/10W	R536	1-216-057-00	METAL GLAZE	2.2K 5% 1/10W
R014	1-216-049-00	METAL GLAZE	1K 5% 1/10W	R538	1-216-025-00	METAL GLAZE	100 5% 1/10W
R015	1-216-296-00	METAL GLAZE	0 5% 1/8W	R539	1-216-657-11	METAL CHIP	1.8K 0.50% 1/10W
R016	1-216-045-00	METAL GLAZE	680 5% 1/10W	R541	1-216-049-00	METAL GLAZE	1K 5% 1/10W
R017	1-216-049-00	METAL GLAZE	1K 5% 1/10W	R542	1-216-025-00	METAL GLAZE	100 5% 1/10W
R018	1-216-041-00	METAL GLAZE	470 5% 1/10W	R544	1-216-085-00	METAL GLAZE	33K 5% 1/10W
R020	1-216-049-00	METAL GLAZE	1K 5% 1/10W	R545	1-216-033-00	METAL GLAZE	220 5% 1/10W
R021	1-216-065-00	METAL GLAZE	4.7K 5% 1/10W	R546	1-216-061-00	METAL GLAZE	3.3K 5% 1/10W
R025	1-216-049-00	METAL GLAZE	1K 5% 1/10W	R547	1-216-049-00	METAL GLAZE	1K 5% 1/10W
R026	1-216-049-00	METAL GLAZE	1K 5% 1/10W	R551	1-216-049-00	METAL GLAZE	1K 5% 1/10W
R028	1-216-075-00	METAL GLAZE	12K 5% 1/10W	R552	1-216-097-00	METAL GLAZE	100K 5% 1/10W
R030	1-216-049-00	METAL GLAZE	1K 5% 1/10W	R553	1-216-085-00	METAL GLAZE	33K 5% 1/10W
R032	1-216-049-00	METAL GLAZE	1K 5% 1/10W	R559	1-216-049-00	METAL GLAZE	1K 5% 1/10W
R033	1-216-049-00	METAL GLAZE	1K 5% 1/10W	R560	1-216-073-00	METAL GLAZE	10K 5% 1/10W
R034	1-216-057-00	METAL GLAZE	2.2K 5% 1/10W	R564	1-216-091-00	METAL GLAZE	56K 5% 1/10W
R035	1-216-057-00	METAL GLAZE	2.2K 5% 1/10W	R565	1-216-065-00	METAL GLAZE	4.7K 5% 1/10W
R038	1-216-073-00	METAL GLAZE	10K 5% 1/10W	R566	1-216-073-00	METAL GLAZE	10K 5% 1/10W
R049	1-216-049-00	METAL GLAZE	1K 5% 1/10W	R567	1-216-085-00	METAL GLAZE	33K 5% 1/10W
R050	1-216-073-00	METAL GLAZE	10K 5% 1/10W	R568	1-216-109-00	METAL GLAZE	330K 5% 1/10W
R051	1-216-081-00	METAL GLAZE	22K 5% 1/10W	R570	1-216-049-00	METAL GLAZE	1K 5% 1/10W
R052	1-216-073-00	METAL GLAZE	10K 5% 1/10W	<VARIABLE RESISTOR>			
R053	1-216-065-00	METAL GLAZE	4.7K 5% 1/10W	RV506	1-241-766-11	RES. ADJ. CERMET 47K	
R054	1-216-081-00	METAL GLAZE	22K 5% 1/10W	*****			
R055	1-216-081-00	METAL GLAZE	22K 5% 1/10W	*A-1638-033-A C BOARD, COMPLETE			
R067	1-216-043-00	METAL GLAZE	560 5% 1/10W	*****			
R068	1-216-043-00	METAL GLAZE	560 5% 1/10W	<CAPACITOR>			
R069	1-216-037-00	METAL GLAZE	330 5% 1/10W	C701	1-162-114-00	CERAMIC	0.0047MF 2KV
R070	1-216-037-00	METAL GLAZE	330 5% 1/10W	C703	1-123-946-00	ELECT	4.7MF 20% 250V
R501	1-216-047-00	METAL GLAZE	820 5% 1/10W	C705	1-162-116-00	CERAMIC	680PF 10% 2KV
R502	1-216-097-00	METAL GLAZE	100K 5% 1/10W	C708	1-163-197-00	CERAMIC CHIP	470PF 10% 50V
R503	1-216-067-00	METAL GLAZE	5.6K 5% 1/10W	C709	1-163-005-11	CERAMIC CHIP	470PF 10% 50V
R504	1-216-063-00	METAL GLAZE	3.9K 5% 1/10W	C710	1-163-005-11	CERAMIC CHIP	470PF 10% 50V
R505	1-216-075-00	METAL GLAZE	12K 5% 1/10W	C711	1-101-880-00	CERAMIC	47PF 5% 50V
R506	1-216-049-00	METAL GLAZE	1K 5% 1/10W	C712	1-163-121-00	CERAMIC CHIP	150PF 5% 50V
R507	1-216-097-00	METAL GLAZE	100K 5% 1/10W				
R509	1-216-039-00	METAL GLAZE	390 5% 1/10W				

C D1

Les composants identifiés par une trame et une marque Δ sont critiques pour la sécurité. Ne les remplacer que par une pièce portant le numéro spécifique.

The components identified by shading and mark Δ are critical for safety. Replace only with part number specified.

REF. NO.	PART NO.	DESCRIPTION	REMARK
C713	1-163-121-00	CERAMIC CHIP 150PF	5% 50V
C714	1-163-121-00	CERAMIC CHIP 150PF	5% 50V
C716	1-124-122-11	ELECT 100MF	20% 50V
<CONNECTOR>			
CN0002*	1-508-786-00	PIN, CONNECTOR (5MM PITCH) 2P	
CN0403*	1-564-511-31	PLUG, CONNECTOR 8P	
CN0421*	1-508-768-00	PIN, CONNECTOR (5MM PITCH) 6P	
<DIODE>			
D701	8-719-911-19	DIODE 1SS119	
D702	8-719-911-19	DIODE 1SS119	
D703	8-719-911-19	DIODE 1SS119	
D704	8-719-911-19	DIODE 1SS119	
D705	8-719-911-19	DIODE 1SS119	
D706	8-719-911-19	DIODE 1SS119	
D707	8-719-911-19	DIODE 1SS119	
D708	8-719-911-19	DIODE 1SS119	
D709	8-719-911-19	DIODE 1SS119	
D710	8-719-911-19	DIODE 1SS119	
D713	8-719-908-03	DIODE GP08D	
<JACK>			
J701	Δ 1-540-223-11	SOCKET, PICTURE TUBE	
<COIL>			
L701	1-410-667-31	INDUCTOR 22UH	
L703	1-408-609-41	INDUCTOR 33UH	
L705	1-408-609-41	INDUCTOR 33UH	
L707	1-408-609-41	INDUCTOR 33UH	
<TRANSISTOR>			
Q701	8-729-906-70	TRANSISTOR BF871	
Q702	8-729-906-70	TRANSISTOR BF871	
Q703	8-729-906-70	TRANSISTOR BF871	
Q704	8-729-906-70	TRANSISTOR BF871	
Q705	8-729-906-70	TRANSISTOR BF871	
Q706	8-729-906-70	TRANSISTOR BF871	
Q707	8-729-200-17	TRANSISTOR 2SA1091-0	
Q708	8-729-200-17	TRANSISTOR 2SA1091-0	
Q709	8-729-200-17	TRANSISTOR 2SA1091-0	
Q710	8-729-901-81	TRANSISTOR 2SC2412K-T-146-R	
Q711	8-729-901-81	TRANSISTOR 2SC2412K-T-146-R	
Q712	8-729-901-81	TRANSISTOR 2SC2412K-T-146-R	
Q713	8-729-216-22	TRANSISTOR 2SA1162-G	
Q714	8-729-255-12	TRANSISTOR 2SC2551-0	
<RESISTOR>			
JR701	1-216-296-00	METAL GLAZE 0 5% 1/8W	
JR703	1-216-296-00	METAL GLAZE 0 5% 1/8W	
R701	1-202-848-00	SOLID 680K 10% 1/2W	
R702	1-202-838-00	SOLID 100K 20% 1/2W	
R703	1-202-815-11	SOLID 47K 20% 1/2W	
R704	1-202-842-11	SOLID 220K 10% 1/2W	
R705	1-216-367-11	METAL OXIDE 0.68 5% 2W	F
R707	1-249-421-11	CARBON 2.2K 5% 1/4W	
R708	1-249-421-11	CARBON 2.2K 5% 1/4W	
R709	1-249-421-11	CARBON 2.2K 5% 1/4W	

REF. NO.	PART NO.	DESCRIPTION	REMARK
R710	1-215-899-11	METAL OXIDE 15K 5% 2W	F
R711	1-202-820-11	SOLID 1.5K 20% 1/2W	
R712	1-215-899-11	METAL OXIDE 15K 5% 2W	F
R713	1-202-820-11	SOLID 1.5K 20% 1/2W	
R714	1-215-899-11	METAL OXIDE 15K 5% 2W	F
R715	1-202-820-11	SOLID 1.5K 20% 1/2W	
R716	1-247-700-11	CARBON 100 5% 1/4W	F
R717	1-249-405-11	CARBON 100 5% 1/4W	F
R718	1-247-700-11	CARBON 100 5% 1/4W	F
R720	1-249-417-11	CARBON 1K 5% 1/4W	F
R722	1-247-713-11	CARBON 1K 5% 1/4W	F
R724	1-249-417-11	CARBON 1K 5% 1/4W	F
R725	1-216-067-00	METAL GLAZE 5.6K 5% 1/10W	
R726	1-216-067-00	METAL GLAZE 5.6K 5% 1/10W	
R727	1-216-067-00	METAL GLAZE 5.6K 5% 1/10W	
R728	1-216-037-00	METAL GLAZE 330 5% 1/10W	
R729	1-216-037-00	METAL GLAZE 330 5% 1/10W	
R730	1-216-037-00	METAL GLAZE 330 5% 1/10W	
R731	1-216-017-00	METAL GLAZE 47 5% 1/10W	
R732	1-216-017-00	METAL GLAZE 47 5% 1/10W	
R733	1-216-017-00	METAL GLAZE 47 5% 1/10W	
R734	1-202-549-00	SOLID 100 20% 1/2W	
R735	1-216-049-00	METAL GLAZE 1K 5% 1/10W	
R738	1-216-025-00	METAL GLAZE 100 5% 1/10W	
R739	1-216-025-00	METAL GLAZE 100 5% 1/10W	
R740	1-216-025-00	METAL GLAZE 100 5% 1/10W	
R741	1-216-089-00	METAL GLAZE 47K 5% 1/10W	
R742	1-216-295-00	METAL GLAZE 0 5% 1/10W	
R743	1-249-434-11	CARBON 27K 5% 1/4W	
R747	1-216-489-11	METAL OXIDE 27K 5% 3W	F
R749	1-216-490-11	METAL OXIDE 39K 5% 3W	F
R751	1-215-926-00	METAL OXIDE 33K 5% 3W	F
R753	1-216-073-00	METAL GLAZE 10K 5% 1/10W	
R755	1-216-065-00	METAL GLAZE 4.7K 5% 1/10W	
R756	1-216-065-00	METAL GLAZE 4.7K 5% 1/10W	
R757	1-216-065-00	METAL GLAZE 4.7K 5% 1/10W	
R758	1-249-419-11	CARBON 1.5K 5% 1/4W	
R759	1-249-419-11	CARBON 1.5K 5% 1/4W	
R760	1-249-419-11	CARBON 1.5K 5% 1/4W	
<VARIABLE RESISTOR>			
RV701	1-230-641-11	RES, ADJ, METAL GLAZE 2.2M	
RV702	1-241-714-11	RES, ADJ, METAL FILM 110M	

*A-1640-098-A D1 BOARD, COMPLETE			

4-382-854-11 SCREW (M3X10), P, SW (+)			
<CAPACITOR>			
C1601	1-124-903-11	ELECT 1MF 20% 50V	
C1602	1-136-177-00	FILM 1MF 5% 50V	
C1603	1-130-772-00	FILM 0.22MF 5% 63V	
C1605	1-126-320-11	ELECT 10MF 20% 16V	
C1606	1-124-910-11	ELECT 47MF 20% 50V	
C1607	1-124-902-00	ELECT 0.47MF 20% 50V	
C1608	1-102-112-00	CERAMIC 330PF 10% 50V	
C1610	1-136-103-00	FILM 0.1MF 5% 200V	
C1611	1-124-903-11	ELECT 1MF 20% 50V	
C1614	1-137-371-11	FILM 0.015MF 5% 50V	
C1615	1-124-903-11	ELECT 1MF 20% 50V	

REF. NO.	PART NO.	DESCRIPTION	REMARK	REF. NO.	PART NO.	DESCRIPTION	REMARK
C1616	1-129-702-00	FILM	0.001MF 10%	400V	D1802	8-719-911-19	DIODE 1SS119
C1617	1-129-702-00	FILM	0.001MF 10%	400V	D1804	8-719-911-19	DIODE 1SS119
C1618	1-102-074-00	CERAMIC	0.001MF 10%	50V	D1805	8-719-801-35	THYRISTOR SHOR3D42(TPE2)
C1620	1-136-601-11	FILM	0.01MF 5%	630V	D1806	8-719-980-78	DIODE ERA83-006
C1622	1-124-557-11	ELECT	1000NF 20%	25V	D1807	8-719-980-78	DIODE ERA83-006
C1623	1-129-702-00	FILM	0.001MF 10%	400V	D1808	8-719-911-19	DIODE 1SS119
C1625	1-126-320-11	ELECT	10MF 20%	16V	D1809	8-719-911-19	DIODE 1SS119
C1626	1-130-777-00	FILM	0.1MF 5%	63V	D1810	8-719-911-19	DIODE 1SS119
C1627	1-136-173-00	FILM	0.47MF 5%	50V	D1811	8-719-936-84	DIODE RGP10GPKG3
C1628	1-124-907-11	ELECT	10MF 20%	50V	D1812	8-719-911-19	DIODE 1SS119
C1629	1-136-557-11	FILM	0.0033MF 10%	630V			
C1630	1-102-244-00	CERAMIC	220PF 10%	500V		<IC>	
C1631	1-124-907-11	ELECT	10MF 20%	50V	IC1601	8-759-135-80	IC UPC358C
C1633	1-124-907-11	ELECT	10MF 20%	50V	IC1603	8-759-987-16	IC LM393P
C1634	1-136-559-11	MYLAR	0.0047MF 10%	400V	IC1604	8-759-987-16	IC LM393P
C1635	1-129-718-00	FILM	0.022MF 10%	630V	IC1801	8-749-920-58	IC SI-3090CA
C1637	1-129-702-00	FILM	0.001MF 10%	400V	IC1802	8-752-052-88	IC CXA1526P
C1680	1-124-797-11	ELECT	0.47MF 20%	160V	IC1803	8-759-135-80	IC UPC358C
C1681	1-129-702-00	FILM	0.001MF 10%	630V		<COIL>	
C1684	1-137-366-11	FILM	0.0022MF 5%	50V	L1601	1-410-093-11	INDUCTOR 33MMH
C1690	1-124-046-00	ELECT	10MF 20%	160V	L1602	1-459-075-00	COIL, DYNAMIC CONVERSION CHOKE
C1801	1-124-910-11	ELECT	47MF 20%	50V	L1607	1-459-148-00	COIL
C1802	1-124-910-11	ELECT	47MF 20%	50V	L1801	1-459-592-11	COIL (WITH CORE) (PMC)
C1803	1-137-370-11	FILM	0.01MF 5%	50V	L1802	1-459-087-00	COIL, HCC DUST CORE 3.9MMH
C1804	1-137-370-11	FILM	0.01MF 5%	50V		<TRANSISTOR>	
C1805	1-130-777-00	FILM	0.1MF 5%	63V	Q1601	8-729-173-38	TRANSISTOR 2SA733-K
C1806	1-130-777-00	FILM	0.1MF 5%	63V	Q1602	8-729-119-78	TRANSISTOR 2SC2785-HFE
C1807	1-124-360-00	ELECT	1000NF 20%	16V	Q1603	8-729-119-78	TRANSISTOR 2SC2785-HFE
C1809	1-136-104-00	FILM	0.16MF 5%	200V	Q1604	8-729-173-38	TRANSISTOR 2SA733-K
C1810	1-136-177-00	FILM	1MF 5%	50V	Q1605	8-729-173-38	TRANSISTOR 2SA733-K
C1811	1-162-318-11	CERAMIC	0.001MF 10%	500V	Q1606	8-729-119-80	TRANSISTOR 2SC2688-LK
C1812	1-124-927-11	ELECT	4.7MF 20%	50V	Q1607	8-729-119-80	TRANSISTOR 2SC2688-LK
C1813	1-106-383-00	MYLAR	0.047MF 10%	100V	Q1608	8-729-140-97	TRANSISTOR 2SB734-34
C1814	1-124-907-11	ELECT	10MF 20%	50V	Q1609	8-729-140-96	TRANSISTOR 2SD774-34
C1815	1-124-907-11	ELECT	10MF 20%	50V	Q1610	8-729-119-78	TRANSISTOR 2SC2785-HFE
C1816	1-124-916-11	ELECT	22MF 20%	50V	Q1611	8-729-119-78	TRANSISTOR 2SC2785-HFE
C1817	1-124-927-11	ELECT	4.7MF 20%	50V	Q1612	8-729-173-38	TRANSISTOR 2SA733-K
C1818	1-124-910-11	ELECT	47MF 20%	50V	Q1613	8-729-931-45	TRANSISTOR 1RF614
C1819	1-130-777-00	FILM	0.1MF 5%	63V	Q1614	8-729-173-38	TRANSISTOR 2SA733-K
C1820	1-126-103-11	ELECT	470MF 20%	16V	Q1615	8-729-011-06	TRANSISTOR 2SC3840K
C1822	1-136-559-11	MYLAR	0.0047MF 10%	400V	Q1616	8-729-173-38	TRANSISTOR 2SA733-K
		<CONNECTOR>			Q1617	8-729-119-78	TRANSISTOR 2SC2785-HFE
CW0607*1-568-879-51		PIN, CONNECTOR 4P			Q1618	8-729-119-78	TRANSISTOR 2SC2785-HFE
CW0622*1-564-512-41		PLUG, CONNECTOR 9P			Q1802	8-729-173-38	TRANSISTOR 2SA733-K
CW0630*1-568-878-51		PIN, CONNECTOR 3P			Q1803	8-729-119-78	TRANSISTOR 2SC2785-HFE
CY1 *1-508-765-00		PIN, CONNECTOR (5MM PITCH) 3P			Q1804	8-729-119-78	TRANSISTOR 2SC2785-HFE
		<DIODE>			Q1805	8-729-177-22	TRANSISTOR 2SB772-Q
D1601	8-719-911-19	DIODE 1SS119			Q1806	8-729-119-78	TRANSISTOR 2SC2785-HFE
D1602	8-719-109-97	DIODE RD6.8ES-B2			Q1807	8-729-140-97	TRANSISTOR 2SB734-34
D1603	8-719-936-84	DIODE RGP10GPKG3			Q1808	8-729-173-38	TRANSISTOR 2SA733-K
D1605	8-719-911-19	DIODE 1SS119			Q1809	8-729-209-15	TRANSISTOR 2SD2012
D1606	8-719-980-78	DIODE ERA83-006			Q1810	8-729-140-96	TRANSISTOR 2SD774-34
D1607	8-719-911-19	DIODE 1SS119			Q1811	8-729-119-78	TRANSISTOR 2SC2785-HFE
D1608	8-719-980-78	DIODE ERA83-006			Q1812	8-729-119-78	TRANSISTOR 2SC2785-HFE
D1611	8-719-911-19	DIODE 1SS119			Q1813	8-729-119-78	TRANSISTOR 2SC2785-HFE
D1612	8-719-970-87	DIODE ERA38-06				<RESISTOR>	
D1613	8-719-109-89	DIODE RD5.6ES-B2			JR1	1-216-295-00	METAL GLAZE 0 5% 1/10W
D1614	8-719-911-19	DIODE 1SS119					
D1680	8-719-970-87	DIODE ERA38-06					
D1801	8-719-980-78	DIODE ERA83-006					

D1 **D2**

REF. NO.	PART NO.	DESCRIPTION	REMARK	REF. NO.	PART NO.	DESCRIPTION	REMARK		
JR2	1-216-296-00	METAL GLAZE	0 5% 1/8W	R1685	1-249-441-11	CARBON	100K 5% 1/4W		
R1601	1-216-061-00	METAL GLAZE	3.3K 5% 1/10W	R1686	1-249-441-11	CARBON	100K 5% 1/4W		
R1602	1-249-433-11	CARBON	22K 5% 1/4W	R1687	1-249-441-11	CARBON	100K 5% 1/4W		
R1603	1-216-073-00	METAL GLAZE	10K 5% 1/10W	R1801	1-249-409-11	CARBON	220 5% 1/4W		
R1604	1-249-429-11	CARBON	10K 5% 1/4W	R1802	1-249-409-11	CARBON	220 5% 1/4W		
R1605	1-216-081-00	METAL GLAZE	22K 5% 1/10W	R1804	1-247-891-00	CARBON	330K 5% 1/4W		
R1606	1-249-425-11	CARBON	4.7K 5% 1/4W	R1806	1-216-103-00	METAL GLAZE	180K 5% 1/10W		
R1607	1-249-436-11	CARBON	39K 5% 1/4W	R1807	1-247-891-00	CARBON	330K 5% 1/4W		
R1608	1-216-685-11	METAL CHIP	27K 0.50% 1/10W	R1808	1-215-461-00	METAL	47K 1% 1/4W		
R1609	1-216-693-11	METAL CHIP	56K 0.50% 1/10W	R1809	1-249-423-11	CARBON	3.3K 5% 1/4W		
R1610	1-216-687-11	METAL CHIP	33K 0.50% 1/10W	R1810	1-249-413-11	CARBON	470 5% 1/4W		
R1611	1-218-758-11	METAL CHIP	180K 0.50% 1/10W	R1811	1-216-083-00	METAL GLAZE	27K 5% 1/10W		
R1612	1-249-425-11	CARBON	4.7K 5% 1/4W	R1812	1-216-091-00	METAL GLAZE	56K 5% 1/10W		
R1613	1-249-425-11	CARBON	4.7K 5% 1/4W	R1813	1-249-417-11	CARBON	1K 5% 1/4W		
R1615	1-249-424-11	CARBON	3.9K 5% 1/4W	R1815	1-216-069-00	METAL GLAZE	6.8K 5% 1/10W		
R1616	1-216-057-00	METAL GLAZE	2.2K 5% 1/10W	R1816	1-216-065-00	METAL GLAZE	4.7K 5% 1/10W		
R1617	1-216-081-00	METAL GLAZE	22K 5% 1/10W	R1817	1-216-059-00	METAL GLAZE	2.7K 5% 1/10W		
R1619	1-216-085-00	METAL GLAZE	33K 5% 1/10W	R1818	1-216-049-00	METAL GLAZE	1K 5% 1/10W		
R1620	1-249-419-11	CARBON	1.5K 5% 1/4W	R1819	1-216-079-00	METAL GLAZE	18K 5% 1/10W		
R1621	1-215-876-00	METAL OXIDE	15K 5% 1W F	R1820	1-249-417-11	CARBON	1K 5% 1/4W		
R1622	1-215-870-11	METAL OXIDE	1.5K 5% 1W F	R1821	1-216-379-11	METAL OXIDE	6.8 5% 2W F		
R1624	1-216-061-00	METAL GLAZE	3.3K 5% 1/10W	R1822	1-249-423-11	CARBON	3.3K 5% 1/4W		
R1625	1-249-430-11	CARBON	12K 5% 1/4W	R1824	1-249-417-11	CARBON	1K 5% 1/4W F		
R1626	1-249-409-11	CARBON	220 5% 1/4W	R1825	1-215-857-11	METAL OXIDE	10 5% 1W F		
R1627	1-249-415-11	CARBON	680 5% 1/4W	R1826	1-249-404-00	CARBON	82 5% 1/4W		
R1628	1-216-057-00	METAL GLAZE	2.2K 5% 1/10W	R1827	1-215-875-11	METAL OXIDE	10K 5% 1W F		
R1629	1-249-429-11	CARBON	10K 5% 1/4W	R1828	1-249-441-11	CARBON	100K 5% 1/4W		
R1630	1-249-433-11	CARBON	22K 5% 1/4W	R1829	1-249-414-11	CARBON	560 5% 1/4W		
R1631	1-216-057-00	METAL GLAZE	2.2K 5% 1/10W	R1830	1-249-411-11	CARBON	330 5% 1/4W		
R1633	1-249-421-11	CARBON	2.2K 5% 1/4W	R1831	1-249-426-11	CARBON	5.6K 5% 1/4W		
R1634	1-216-093-00	METAL GLAZE	68K 5% 1/10W	R1832	1-215-864-00	METAL OXIDE	150 5% 1W F		
R1635	1-216-073-00	METAL GLAZE	10K 5% 1/10W	R1833	1-249-421-11	CARBON	2.2K 5% 1/4W		
R1636	1-216-073-00	METAL GLAZE	10K 5% 1/10W	R1834	1-216-081-00	METAL GLAZE	22K 5% 1/10W		
R1637	1-216-057-00	METAL GLAZE	2.2K 5% 1/10W	R1835	1-249-393-11	CARBON	10 5% 1/4W		
R1638	1-249-405-11	CARBON	100 5% 1/4W	R1836	1-249-435-11	CARBON	33K 5% 1/4W		
R1639	1-249-405-11	CARBON	100 5% 1/4W F	R1837	1-249-435-11	CARBON	33K 5% 1/4W		
R1640	1-249-405-11	CARBON	100 5% 1/4W F	R1838	1-216-379-11	METAL OXIDE	6.8 5% 2W F		
R1641	1-249-405-11	CARBON	100 5% 1/4W	R1839	1-249-410-11	CARBON	270 5% 1/4W		
R1644	1-216-081-00	METAL GLAZE	22K 5% 1/10W	R1840	1-249-429-11	CARBON	10K 5% 1/4W		
R1645	1-216-113-00	METAL GLAZE	470K 5% 1/10W	R1841	1-249-437-11	CARBON	47K 5% 1/4W		
R1646	1-216-065-00	METAL GLAZE	4.7K 5% 1/10W	R1842	1-249-429-11	CARBON	10K 5% 1/4W		
R1647	1-216-067-00	METAL GLAZE	5.6K 5% 1/10W	R1843	1-249-421-11	CARBON	2.2K 5% 1/4W		
R1648	1-249-435-11	CARBON	33K 5% 1/4W	R1846	1-249-429-11	CARBON	10K 5% 1/4W		
R1650	1-249-425-11	CARBON	4.7K 5% 1/4W	R1847	1-216-065-00	METAL GLAZE	4.7K 5% 1/10W		
R1652	1-216-025-00	METAL GLAZE	100 5% 1/10W	R1848	1-249-429-11	CARBON	10K 5% 1/4W		
R1653	1-216-107-00	METAL GLAZE	270K 5% 1/10W	R1849	1-216-065-00	METAL GLAZE	4.7K 5% 1/10W		
R1654	1-247-889-00	CARBON	270K 5% 1/4W	R1850	1-249-415-11	CARBON	680 5% 1/4W		
R1655	1-215-876-00	METAL OXIDE	15K 5% 1W F	*****					
R1656	1-249-413-11	CARBON	470 5% 1/4W	*A-1640-106-A D2 BOARD, COMPLETE					
R1657	1-249-393-11	CARBON	10 5% 1/4W F	*****					
R1658	1-249-437-11	CARBON	47K 5% 1/4W	<CAPACITOR>					
R1659	1-216-295-00	METAL GLAZE	0 5% 1/10W	C1851	1-124-910-11	ELECT	47NF	20%	50V
R1660	1-216-089-00	METAL GLAZE	47K 5% 1/10W	C1853	1-124-907-11	ELECT	10MF	20%	50V
R1661	1-216-073-00	METAL GLAZE	10K 5% 1/10W	C1854	1-124-910-11	ELECT	47MF	20%	50V
R1662	1-216-097-00	METAL GLAZE	100K 5% 1/10W	C1855	1-137-047-11	FILM	0.01MF	10%	400V
R1664	1-249-412-11	CARBON	390 5% 1/4W F	C1858	1-163-275-11	CERAMIC CHIP	0.001MF	5%	50V
R1665	1-218-078-51	METAL OXIDE	2.2K 5% 2W	C1859	1-163-275-11	CERAMIC CHIP	0.001MF	5%	50V
R1666	1-218-078-51	METAL OXIDE	2.2K 5% 2W	C1860	1-137-104-11	FILM	0.033MF	10%	250V
R1671	1-216-081-00	METAL GLAZE	22K 5% 1/10W	C1861	1-137-104-11	FILM	0.033MF	10%	250V
R1680	1-249-417-11	CARBON	1K 5% 1/4W	C1862	1-124-657-00	ELECT	10MF	20%	50V
R1681	1-249-429-11	CARBON	10K 5% 1/4W						
R1682	1-249-433-11	CARBON	22K 5% 1/4W						
R1683	1-249-411-11	CARBON	330 5% 1/4W						
R1684	1-249-435-11	CARBON	33K 5% 1/4W						

D

Les composants identifiés par une trame et une marque Δ sont critiques pour la sécurité. Ne les remplacer que par une pièce portant le numéro spécifique.

The components identified by shading and mark Δ are critical for safety. Replace only with part number specified.

REF. NO.	PART NO.	DESCRIPTION	REMARK	REF. NO.	PART NO.	DESCRIPTION	REMARK
C807	1-136-553-11	FILM 0.0015MF	10%	400V	<CONNECTOR>		
C808	1-162-114-00	CERAMIC 0.0047MF		2KV	CN0004*1-508-786-00	PIN, CONNECTOR (5MM PITCH) 2P	
C809	1-124-808-51	ELECT 10MF	20%	200V	CN0009 1-568-878-51	PIN, CONNECTOR 3P	
C810	1-163-001-11	CERAMIC CHIP 220PF	10%	50V	CN0504*1-568-882-51	PIN, CONNECTOR 7P	
C812	1-162-318-11	CERAMIC 0.001MF	10%	500V	CN0505*1-568-880-51	PIN, CONNECTOR 5P	
C813	1-108-704-11	MYLAR 0.1MF	10%	200V	CN0506*1-568-880-51	PIN, CONNECTOR 5P	
C815	1-162-117-00	CERAMIC 100PF	10%	500V	CN0519*1-568-878-51	PIN, CONNECTOR 3P	
C816	1-102-244-00	CERAMIC 220PF	10%	500V	CN0521*1-568-765-00	PIN, CONNECTOR (5MM PITCH) 3P	
C819	1-126-103-11	ELECT 470MF	20%	16V	CN0522*1-564-512-41	PLUG, CONNECTOR 9P	
C821	Δ 1-137-347-11	FILM 0.022MF	3%	2KV	CN0523 1-573-296-11	CONNECTOR, BOARD TO BOARD 10P	
C822	Δ 1-162-116-91	CERAMIC 680PF	10%	2KV	CN0524*1-568-878-51	PIN, CONNECTOR 3P	
C823	1-124-902-00	ELECT 0.47MF	20%	50V	CN0525*1-695-294-11	PIN, CONNECTOR (PC BOARD) 6P	
C824	1-137-366-11	FILM 0.0022MF	5%	50V	CN0526*1-568-881-51	PIN, CONNECTOR 6P	
C825	Δ 1-162-116-91	CERAMIC 680PF	10%	2KV	CN0529*1-508-784-00	PIN, CONNECTOR (5MM PITCH) 1P	
C826	Δ 1-137-515-61	FILM 0.056MF	3%	400V	CN5521*1-568-878-51	PIN, CONNECTOR 3P	
C827	1-130-777-00	FILM 0.1MF	5%	63V	DY1 *1-580-798-11	CONNECTOR PIN (DY) 6P	
C828	1-136-557-11	FILM 0.0033MF	10%	400V	<DIODE>		
C830	1-136-105-00	FILM 0.33MF	5%	200V	D602 8-719-936-84	DIODE RGP10GPKG3	
C831	1-123-932-00	ELECT 4.7MF	20%	160V	D606 8-719-936-84	DIODE RGP10GPKG3	
C832	1-124-910-11	ELECT 47MF	20%	50V	D608 8-719-300-33	DIODE RU-3AM	
C833	1-137-516-11	FILM 1.2MF	5%	200V	D609 8-719-029-04	DIODE D5L60	
C834	1-137-114-11	FILM 0.68MF	5%	200V	D610 8-719-970-39	DIODE ESAC92M-02	
C835	1-124-480-11	ELECT 470MF	20%	25V	D611 8-719-029-04	DIODE D5L60	
C836	1-102-228-00	CERAMIC 470PF	10%	500V	D612 8-719-510-09	DIODE D10SC6M	
C837	1-129-702-00	FILM 0.001MF	10%	400V	D613 8-719-920-68	DIODE ESAB92-02	
C838	1-108-704-11	MYLAR 0.1MF	10%	200V	D614 8-719-920-68	DIODE ESAB92-02	
C839	1-123-950-00	ELECT 47MF	20%	250V	D616 8-719-110-31	DIODE RD12ES-B2	
C840	1-124-480-11	ELECT 470MF	20%	25V	D619 8-719-400-18	DIODE MA152WK	
C841	1-102-228-00	CERAMIC 470PF	10%	500V	D620 8-719-911-19	DIODE 1SS119	
C842	1-104-722-91	FILM 0.068MF	10%	250V	D624 8-719-312-40	DIODE R2K	
C846	1-123-024-21	ELECT 33MF		160V	D801 8-719-018-82	DIODE RGP02-20EL-6394	
C851	1-137-364-91	FILM 0.001MF	5%	50V	D802 8-719-936-84	DIODE RGP10GPKG3	
C852	1-164-299-11	CERAMIC CHIP 0.22MF	10%	25V	D804 8-719-400-18	DIODE MA152WK	
C853	1-124-910-11	ELECT 47MF	20%	50V	D808 8-719-109-88	DIODE RD5.6ES-B1	
C854	Δ 1-162-115-91	CERAMIC 330PF	10%	2KV	D809 8-719-110-03	DIODE RD7.5ES-B2	
C857	1-124-902-00	ELECT 0.47MF	20%	50V	D811 8-719-300-33	DIODE RU-3AM	
C861	1-130-777-00	FILM 0.1MF	5%	63V	D812 8-719-908-03	DIODE GPO8D	
C863	1-106-383-00	MYLAR 0.047MF	10%	100V	D813 8-719-908-03	DIODE GPO8D	
C866	1-137-364-91	FILM 0.001MF	5%	50V	D814 8-719-028-29	DIODE RU30ALFS1	
C869	1-130-777-00	FILM 0.1MF	5%	63V	D815 8-719-936-84	DIODE RGP10GPKG3	
C870	1-137-364-91	FILM 0.001MF	5%	50V	D816 8-719-979-85	DIODE EGP20G	
C871	1-130-651-00	FILM 0.001MF	2%	100V	D818 8-719-109-93	DIODE RD6.2ES-B2	
C872	1-124-907-11	ELECT 10MF	20%	50V	D821 8-719-400-18	DIODE MA152WK	
C873	1-137-364-91	FILM 0.001MF	5%	50V	D822 8-719-982-20	DIODE WTZJ-30B	
C875	1-102-038-00	CERAMIC 0.001MF		500V	D824 8-719-976-64	DIODE RGP02-17	
C877	1-124-902-00	ELECT 0.47MF	20%	50V	D825 8-719-400-18	DIODE MA152WK	
C878	1-164-232-11	CERAMIC CHIP 0.01MF	10%	50V	D826 8-719-400-18	DIODE MA152WK	
C879	1-102-228-00	CERAMIC 470PF	10%	500V	D827 8-719-982-96	DIODE MTZJ-T-77-2.2A	
C1501	1-163-141-00	CERAMIC CHIP 0.001MF	5%	50V	D828 8-719-911-19	DIODE 1SS119	
C1502	1-124-903-11	ELECT 1MF	20%	50V	D830 8-719-400-18	DIODE MA152WK	
C1503	1-163-141-00	CERAMIC CHIP 0.001MF	5%	50V	D831 8-719-400-18	DIODE MA152WK	
C1504	1-124-480-11	ELECT 470MF	20%	25V	D832 8-719-400-18	DIODE MA152WK	
C1505	1-124-911-11	ELECT 220MF	20%	50V	D833 8-719-400-18	DIODE MA152WK	
C1506	1-136-202-11	FILM 0.33MF	5%	63V	D1501 8-719-400-18	DIODE MA152WK	
C1507	1-106-224-00	MYLAR 0.15MF	10%	100V	D1503 8-719-908-03	DIODE GPO8D	
C1508	1-124-480-11	ELECT 470MF	20%	25V	D1504 8-719-982-03	DIODE MTZJ-3.6A	
C1509	1-124-767-00	ELECT 2.2MF	20%	50V	<IC>		
C1511	1-124-907-11	ELECT 10MF	20%	50V	IC601 8-759-073-29	IC TDA4605-3	
C1512	1-124-006-11	ELECT 10MF	20%	25V	IC602 8-759-908-15	IC TL431CLP-Z20	
C1513	1-163-113-00	CERAMIC CHIP 68PF	5%	50V	IC603 Δ 8-749-923-44	IC SFN617G-1	
C1514	1-164-004-11	CERAMIC CHIP 0.1MF	10%	25V			
C1515	1-164-004-11	CERAMIC CHIP 0.1MF	10%	25V			

SONY SERVICE MANUAL

AE-2 CHASSIS

MODEL	COMMANDER	DEST.	CHASSIS NO.	MODEL	COMMANDER	DEST.	CHASSIS NO.
<i>KV-S3411A</i>	<i>RM-832</i>	<i>Italian</i>	<i>SCC-F18K-A</i>	<i>KV-S3413E</i>	<i>RM-832</i>	<i>Spanish</i>	<i>SCC-F33K-A</i>
<i>KV-S3411B</i>	<i>RM-832</i>	<i>French</i>	<i>SCC-F32K-A</i>	<i>KV-S3412U</i>	<i>RM-832</i>	<i>UK</i>	<i>SCC-F25J-A</i>
<i>KV-S3411D</i>	<i>RM-832</i>	<i>AEP</i>	<i>SCC-F26K-A</i>				

CORRECTION-1

SUBJECT: CORRECTED CIRCUIT DIAGRAM

File this correction with the service manual.



SECTION 5 DIAGRAMS
5-4. SCHEMATIC DIAGRAMS AND PRINTED WIRING BOARDS
E1 BOARD (KV-S3411B only)

- A BOARD -

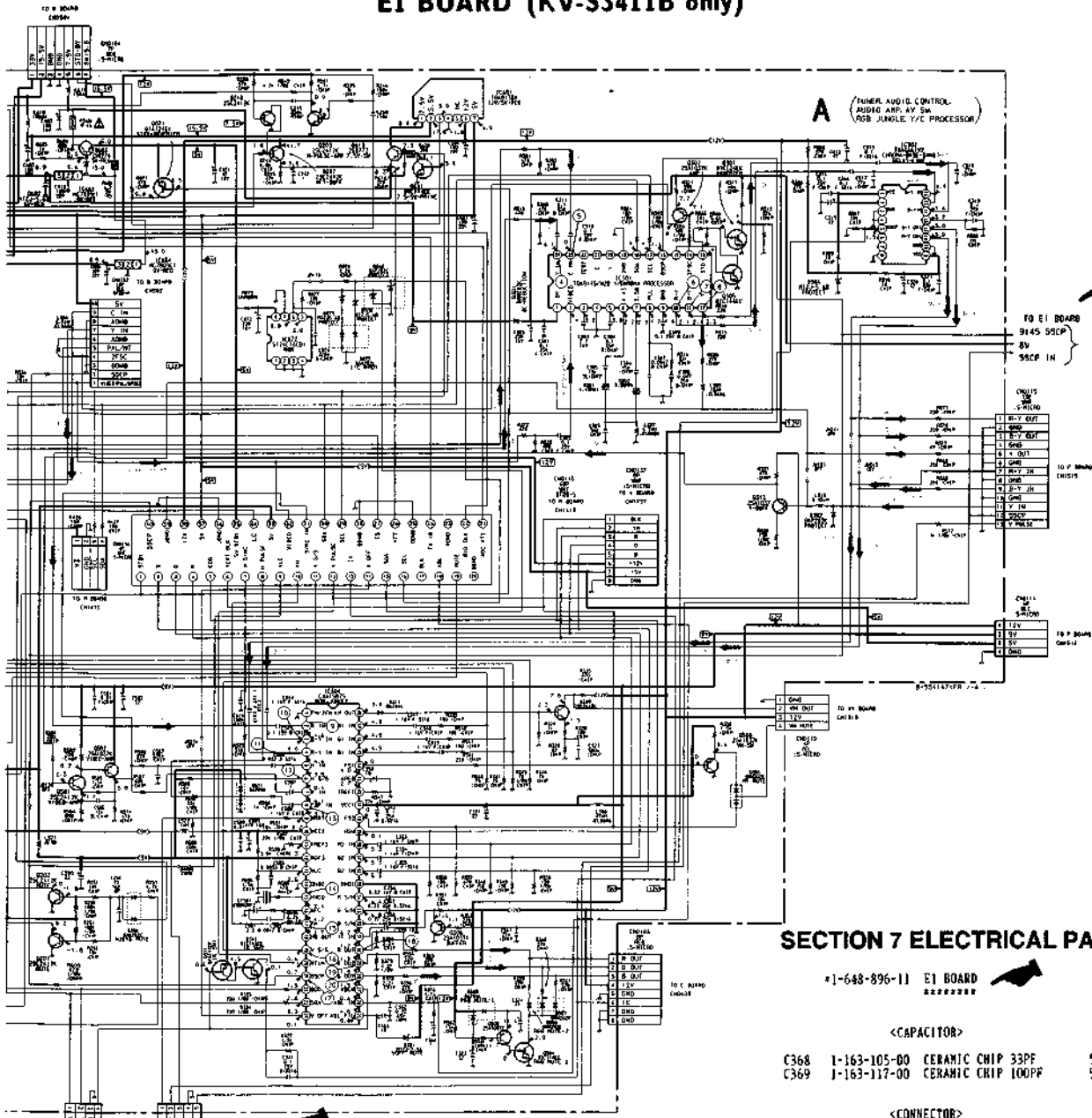

- E1 BOARD -

- E1 BOARD -

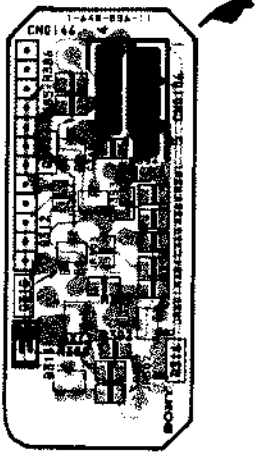
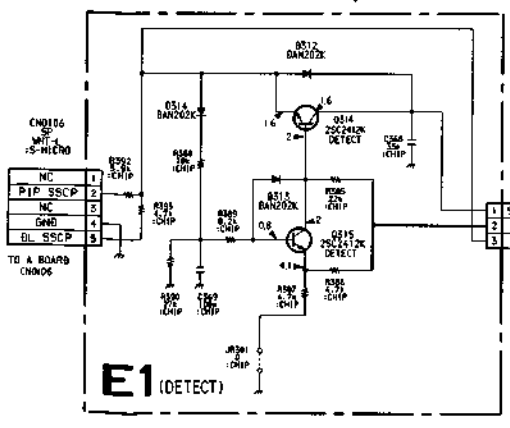

SECTION 7 ELECTRICAL PARTS LIST

*1-648-896-11 E1 BOARD

<CAPACITOR>

C368	1-163-105-00	CERAMIC CHIP 33PF	5X	50V
C369	1-163-117-00	CERAMIC CHIP 100PF	5X	50V

<CONNECTOR>

CN106*	1-564-291-00	PIN, CONNECTOR (L TYPE) 5P
CN104*	1-568-878-51	PIN, CONNECTOR 3P

<DIODE>

D312	8-719-914-43	DIODE DAN202K
D313	8-719-914-43	DIODE DAN202K
D314	8-719-914-43	DIODE DAN202K

<TRANSISTOR>

Q314	8-729-920-74	TRANSISTOR 2SC2412K-QR
Q315	8-729-920-74	TRANSISTOR 2SC2412K-QR

<RESISTOR>

JR301	1-216-295-91	METAL GLAZE	0	5X	1/10W
JR303	1-216-295-91	METAL GLAZE	0	5X	1/10W
JR304	1-216-295-91	METAL GLAZE	0	5X	1/10W
R385	1-216-081-00	METAL GLAZE	22K	5X	1/10W
R386	1-216-065-00	METAL GLAZE	4.7K	5X	1/10W
R387	1-216-065-00	METAL GLAZE	4.7K	5X	1/10W
R388	1-216-073-00	METAL GLAZE	10K	5X	1/10W
R389	1-216-071-00	METAL GLAZE	8.2K	5X	1/10W
R390	1-216-083-00	METAL GLAZE	27K	5X	1/10W
R392	1-216-063-00	METAL GLAZE	3.9K	5X	1/10W
R393	1-216-065-00	METAL GLAZE	4.7K	5X	1/10W

The components identified by shading and mark Δ are critical for safety. Replace only with part number specified.

Les composants identifiés par une trame et une marque Δ sont critiques pour la sécurité. Ne les remplacer que par une pièce portant le numéro spécifié.

REF. NO.	PART NO.	DESCRIPTION	REMARK	REF. NO.	PART NO.	DESCRIPTION	REMARK
IC801	8-759-987-16	IC LM393P		JR005	1-216-295-00	METAL GLAZE	0 5% 1/10W
IC802	8-759-987-16	IC LM393P		JR006	1-216-295-00	METAL GLAZE	0 5% 1/10W
IC803	8-759-081-31	IC MCT8L12ACPRP		JR500	1-216-296-00	METAL GLAZE	0 5% 1/8W
IC1501	8-759-506-46	IC TDA8179S		JR501	1-216-296-00	METAL GLAZE	0 5% 1/8W
<COIL>				JR502	1-216-296-00	METAL GLAZE	0 5% 1/8W
L602	1-410-397-21	FERRITE BEAD INDUCTOR		JR503	1-216-296-00	METAL GLAZE	0 5% 1/8W
L603	1-410-396-41	FERRITE BEAD INDUCTOR		JR504	1-216-296-00	METAL GLAZE	0 5% 1/8W
L604	1-410-396-41	FERRITE BEAD INDUCTOR		JR505	1-216-296-00	METAL GLAZE	0 5% 1/8W
L605	1-459-442-00	COIL (WITH CORE)		JR506	1-216-296-00	METAL GLAZE	0 5% 1/8W
L606	1-459-442-00	COIL (WITH CORE)		JR507	1-216-296-00	METAL GLAZE	0 5% 1/8W
L610	1-410-397-21	FERRITE BEAD INDUCTOR		JR508	1-216-296-00	METAL GLAZE	0 5% 1/8W
L622	1-412-533-21	INDUCTOR 47UH		JR509	1-216-296-00	METAL GLAZE	0 5% 1/8W
L623	1-412-533-21	INDUCTOR 47UH		JR510	1-216-296-00	METAL GLAZE	0 5% 1/8W
L802	1-408-947-00	INDUCTOR 2.2MMH		JR511	1-216-296-00	METAL GLAZE	0 5% 1/8W
L803	1-420-872-00	COIL, AIR CORE		R601	1-216-353-00	METAL OXIDE	2.2 5% 1W F
L804	1-410-396-41	FERRITE BEAD INDUCTOR		R602	1-216-065-00	METAL GLAZE	4.7K 5% 1/10W
L807	1-459-483-00	COIL (WITH CORE)		R603	1-215-901-00	METAL OXIDE	33K 5% 2W F
J08	1-421-541-00	COIL, CHOKE 1000UH		R604	1-260-200-11	CARBON	240K 5% 1/2W
L809	1-459-104-00	COIL, WITH CORE		R605	1-216-313-00	METAL GLAZE	8.2 5% 1/10W
L810	1-460-197-21	COIL, FERRITE (PMC)		R606	1-216-033-00	METAL GLAZE	220 5% 1/10W
L811	1-412-519-11	INDUCTOR 3.3UH		R607	1-216-061-00	METAL GLAZE	3.3K 5% 1/10W
L812	1-412-531-31	INDUCTOR 33UH		R608	1-215-928-11	METAL OXIDE	68K 5% 3W F
L813	1-412-519-11	INDUCTOR 3.3UH		R609	1-216-005-00	METAL GLAZE	15 5% 1/10W
L817	1-423-374-11	TRANSFORMER, LINEARITY (HLT)		R610	1-247-881-00	CARBON	120K 5% 1/4W
L1501	1-412-525-21	INDUCTOR 10UH		R611	1-249-405-11	CARBON	100 5% 1/4W
L1502	1-412-525-21	INDUCTOR 10UH		R612	1-247-894-11	CARBON	430K 5% 1/4W
L1503	1-412-525-21	INDUCTOR 10UH		R613	1-216-260-00	METAL GLAZE	390K 5% 1/8W
<IC LINK>				R614	1-216-488-11	METAL OXIDE	18K 5% 3W F
PS601A	1-532-686-91	LINK, IC 2.7A		R615	1-216-488-11	METAL OXIDE	18K 5% 3W F
PS602A	1-532-686-91	LINK, IC 2.7A		R617	1-216-033-00	METAL GLAZE	220 5% 1/10W
PS603A	1-532-686-91	LINK, IC 2.7A		R618	1-216-449-11	METAL OXIDE	56 5% 2W F
PS604A	1-532-686-91	LINK, IC 2.7A		R620	1-216-045-00	METAL GLAZE	680 5% 1/10W
<TRANSISTOR>				R621	1-216-659-11	METAL CHIP	2.2K 0.50% 1/10W
Q601	8-729-016-14	TRANSISTOR BUZ91A-E3155		R622	1-216-041-00	METAL GLAZE	470 5% 1/10W
Q602	8-729-177-22	TRANSISTOR 2SB772-Q		R623	1-216-073-00	METAL GLAZE	10K 5% 1/10W
Q603	8-729-900-53	TRANSISTOR DTC114EK		R625	1-216-449-11	METAL OXIDE	56 5% 2W F
Q611	8-729-119-78	TRANSISTOR 2SC2785-HFE		R626	1-216-635-11	METAL CHIP	220 0.50% 1/10W
Q612	8-729-903-29	TRANSISTOR DTA144TK		R627	1-249-398-11	CARBON	27 5% 1/4W F
Q613	8-729-216-22	TRANSISTOR 2SA1162-G		R629	1-215-460-00	METAL	43K 1% 1/4W
Q801	8-729-016-32	TRANSISTOR 2SC4927-01		R630	1-260-100-11	CARBON	1.2K 5% 1/2W
Q802	8-729-140-97	TRANSISTOR 2SB734-34		R631	1-216-397-11	METAL OXIDE	4.7 5% 3W F
Q804	8-729-216-22	TRANSISTOR 2SA1162-G		R633	1-249-415-11	CARBON	680 5% 1/4W
Q805	8-729-216-22	TRANSISTOR 2SA1162-G		R634	1-215-477-00	METAL	220K 1% 1/4W
Q806	8-729-019-71	TRANSISTOR 2SK1916-53-F50		R635	1-216-073-00	METAL GLAZE	10K 5% 1/10W
Q807	8-729-119-80	TRANSISTOR 2SC2688-LK		R636	1-216-453-00	METAL OXIDE	270 5% 2W F
Q812	8-729-901-81	TRANSISTOR 2SC2412K-T-146-R		R637	1-216-113-00	METAL GLAZE	470K 5% 1/10W
Q813	8-729-140-96	TRANSISTOR 2SD774-34		R638	1-216-073-00	METAL GLAZE	10K 5% 1/10W
Q818	8-729-216-22	TRANSISTOR 2SA1162-G		R639	1-216-089-00	METAL GLAZE	47K 5% 1/10W
Q1501	8-729-901-81	TRANSISTOR 2SC2412K-T-146-R		R640	1-207-905-00	WIREWOUND	0.27 10% 2W F
Q1502	8-729-901-01	TRANSISTOR DTC144EK		R645	1-214-775-00	METAL	82K 1% 1/4W
Q1503	8-729-216-22	TRANSISTOR 2SA1162-G		R646	1-216-097-00	METAL GLAZE	100K 5% 1/10W
Q1504	8-729-901-01	TRANSISTOR DTC144EK		R647	1-216-059-00	METAL GLAZE	2.7K 5% 1/10W
<RESISTOR>				R651	1-216-069-00	METAL GLAZE	6.8K 5% 1/10W
JR001	1-216-295-00	METAL GLAZE	0 5% 1/10W	R801	1-216-071-00	METAL GLAZE	8.2K 5% 1/10W
JR002	1-216-295-00	METAL GLAZE	0 5% 1/10W	R802	1-216-295-00	METAL GLAZE	0 5% 1/10W
JR003	1-216-295-00	METAL GLAZE	0 5% 1/10W	R804	1-217-778-11	FUSIBLE	1K 5% 1W F
JR004	1-216-295-00	METAL GLAZE	0 5% 1/10W	R805	1-216-679-11	METAL CHIP	15K 0.50% 1/10W
				R806	1-216-061-00	METAL GLAZE	3.3K 5% 1/10W
				R807	1-216-037-00	METAL GLAZE	330 5% 1/10W
				R808	1-216-085-00	METAL GLAZE	33K 5% 1/10W
				R809	1-216-097-00	METAL GLAZE	100K 5% 1/10W
				R811	1-216-033-00	METAL GLAZE	220 5% 1/10W
				R812	1-216-061-00	METAL GLAZE	3.3K 5% 1/10W

D

Les composants identifiés par une trame et une marque Δ sont critiques pour la sécurité. Ne les remplacer que par une pièce portant le numéro spécifique.

The components identified by shading and mark Δ are critical for safety. Replace only with part number specified.

REF. NO.	PART NO.	DESCRIPTION	REMARK	REF. NO.	PART NO.	DESCRIPTION	REMARK
R813	1-216-065-00	METAL GLAZE	4.7K 5% 1/10W	R1550	1-216-105-00	METAL GLAZE	220K 5% 1/10W
R814	1-216-091-00	METAL GLAZE	56K 5% 1/10W	R1551	1-216-065-00	METAL GLAZE	4.7K 5% 1/10W
R815	1-216-081-00	METAL GLAZE	22K 5% 1/10W	R1552	1-216-105-00	METAL GLAZE	220K 5% 1/10W
R819	1-247-755-11	CARBON	1.8K 5% 1/2W F			<VARIABLE RESISTOR>	
R820	1-216-097-00	METAL GLAZE	100K 5% 1/10W	RV601	1-241-628-11	RES, ADJ, CARBON 2.2K	
R821	1-216-481-11	METAL OXIDE	1.2K 5% 3W F			<TRANSFORMER>	
R822	1-216-481-11	METAL OXIDE	1.2K 5% 3W F	T601	Δ 1-697-001-11	S.R.T (SMT89)	
R823	1-216-065-00	METAL GLAZE	4.7K 5% 1/10W	T801	Δ 1-453-126-11	TRANSFORMER ASSY. FLYBACK (MX-3000A3)	
R824	1-216-673-11	METAL CHIP	8.2K 0.50% 1/10W	T803	1-437-090-00	HDT	
R825	1-216-342-11	METAL OXIDE	0.27 5% 1W F	T804	1-424-584-11	TRANSFORMER, DYNAMIC FOCUS	
R826	1-216-166-00	METAL GLAZE	47 5% 1/8W			*****	
R828	1-216-121-00	METAL GLAZE	1M 5% 1/10W			MISCELLANEOUS	
R829	1-249-429-11	CARBON	10K 5% 1/4W F			*****	
R830	1-216-687-11	METAL CHIP	33K 0.50% 1/10W	Δ 1-406-701-11	COIL, DEMAGNETIZATION		
R832	1-216-089-00	METAL GLAZE	47K 5% 1/10W	Δ 1-406-702-11	COIL, DEMAGNETIZATION		
R833	1-216-105-00	METAL GLAZE	220K 5% 1/10W	Δ 1-451-393-11	DEFLECTION YOKS (Y34EXA)		
R834	1-216-101-00	METAL GLAZE	150K 5% 1/10W	1-452-032-00	MAGNET, DISK; 10MM ϕ		
R835	1-216-057-00	METAL GLAZE	2.2K 5% 1/10W	1-452-094-00	MAGNET, ROTATABLE DISK; 15MM ϕ		
R836	1-216-242-00	METAL GLAZE	68K 5% 1/8W			*****	
R837	1-216-695-11	METAL CHIP	68K 0.50% 1/10W	Δ 1-452-616-13	NECK ASSY, PICTURE TUBE (NA323)		
R838	1-216-097-00	METAL GLAZE	100K 5% 1/10W	1-504-121-21	SPEAKER (SQUAWKER) (5CM)		
R839	1-216-061-00	METAL GLAZE	3.3K 5% 1/10W	1-504-145-11	SPEAKER (12CM)		
R841	1-249-397-11	CARBON	22 5% 1/4W F	Δ 1-590-501-11	CORD, POWER (WITH NOISE FILTER)		
R842	1-216-454-11	METAL OXIDE	390 5% 2W F			(KV-S3411A, S3411B, S3411D, S3413E)	
R846	1-216-671-11	METAL CHIP	6.8K 0.50% 1/10W	Δ 1-590-762-11	CORD, POWER (WITH PLUG) (KV-S3412U)		
R847	1-216-097-00	METAL GLAZE	100K 5% 1/10W			*****	
R848	1-215-885-00	METAL OXIDE	68 5% 2W F	V901	Δ 8-733-731-05	PICTURE TUBE (M81KVA10X)	
R849	1-215-881-11	METAL OXIDE	15 5% 2W F			*****	
R851	1-247-743-11	CARBON	220 5% 1/2W F			ACCESSORIES AND PACKING MATERIALS	
R852	1-249-389-11	CARBON	4.7 5% 1/4W F			*****	
R853	1-249-443-11	CARBON	0.47 5% 1/4W F	4-202-091-41	MANUAL, INSTRUCTION (KV-S3411A)		
R854	1-249-443-11	CARBON	0.47 5% 1/4W F	4-202-091-51	MANUAL, INSTRUCTION (KV-S3411B)		
R855	1-202-826-00	SOLID	4.7K 20% 1/2W	4-202-091-11	MANUAL, INSTRUCTION (KV-S3411D)		
R858	1-249-423-11	CARBON	3.3K 5% 1/4W	4-202-091-61	MANUAL, INSTRUCTION (KV-S3412U)		
R864	1-216-687-11	METAL CHIP	33K 0.50% 1/10W	4-202-091-71	MANUAL, INSTRUCTION (KV-S3413E)		
R865	1-215-493-00	METAL	1M 1% 1/4W	4-202-091-82	MANUAL, INSTRUCTION (KV-S3413E)		
R866	1-216-687-11	METAL CHIP	33K 0.50% 1/10W	4-202-137-01	DOOR, REAR		
R867	1-216-113-00	METAL GLAZE	470K 5% 1/10W	*4-202-248-01	BAG, PROTECTION		
R868	1-249-428-11	CARBON	8.2K 5% 1/4W	*4-202-271-01	CUSHION (UPPER) (ASSY)		
R871	1-249-493-11	CARBON	56K 5% 1/2W	*4-202-272-01	CUSHION (LOWER) (ASSY)		
R872	1-249-393-11	CARBON	10 5% 1/4W F	*4-202-273-01	TRAY		
R873	1-249-393-11	CARBON	10 5% 1/4W F	*4-202-274-01	INDIVIDUAL CARTON		
R876	1-249-421-11	CARBON	2.2K 5% 1/4W	*4-202-279-01	PALLET		
R877	1-215-907-11	METAL OXIDE	22 5% 3W F	*4-396-077-01	JOINT		
R884	1-216-697-11	METAL CHIP	82K 0.50% 1/10W			REMOTE COMMANDER	
R889	1-216-089-00	METAL GLAZE	47K 5% 1/10W	1-466-804-11	REMOTE COMMANDER (RM-832)		
R891	1-216-025-00	METAL GLAZE	100 5% 1/10W	9-903-466-01	COVER, POCKET (FOR RM-832)		
R893	1-215-878-00	METAL OXIDE	33K 5% 1W F				
R894	1-216-264-00	METAL GLAZE	560K 5% 1/8W				
R895	1-216-079-00	METAL GLAZE	18K 5% 1/10W				
R897	1-216-089-00	METAL GLAZE	47K 5% 1/10W				
R898	1-216-262-00	METAL GLAZE	470K 5% 1/8W				
R1501	1-216-674-11	METAL CHIP	9.1K 0.50% 1/10W				
R1502	1-216-663-11	METAL CHIP	3.3K 0.50% 1/10W				
R1503	1-216-065-00	METAL GLAZE	4.7K 5% 1/10W				
R1504	1-216-081-00	METAL GLAZE	22K 5% 1/10W				
R1505	1-216-081-00	METAL GLAZE	22K 5% 1/10W				
R1506	1-216-057-00	METAL GLAZE	2.2K 5% 1/10W				
R1508	1-216-683-11	METAL CHIP	22K 0.50% 1/10W				
R1509	1-216-085-00	METAL GLAZE	33K 5% 1/10W				
R1510	1-249-382-11	CARBON	1.2 5% 1/4W F				
R1511	1-215-888-00	METAL OXIDE	220 5% 2W F				
R1512	1-216-370-11	METAL OXIDE	1.2 5% 2W F				
R1514	1-216-049-00	METAL GLAZE	1K 5% 1/10W				