

AKAI SERVICE MANUAL

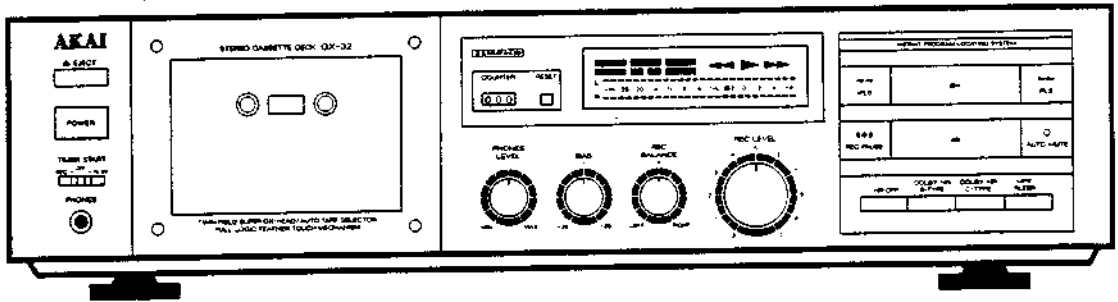

STEREO CASSETTE DECK

MODEL GX-32

SPECIFICATIONS

Track system	4 track 2 channel stereo	Input sensitivity/Impedances	
Heads	Twin field super GX head for recording and playback × 1 Erase head × 1	LINE	70 mV/47 k ohms
Motors	Electronically speed controlled DC motor for capstan drive × 1	Output sensitivity/Impedance	
Wow & flutter	0.05% WRMS (JIS), 0.09% (DIN)	LINE	388 mV/20 k ohms
S/N (Metal)	59 dB (Measured via tape with 3% THD recording level)	HEADPHONES ..	1.3 mW/8 ohms
	Dolby B type NR switch ON: Improves up to 5 dB at 1 kHz, 10 dB above 5 kHz	Power requirements ..	120 V, 60 Hz for USA & Canada 220 V, 50 Hz for Europe except UK 240 V, 50 Hz for UK and Australia 110 V/120 V/220 V/240 V, 50/60 Hz convertible for other countries
	Dolby C type NR switch ON: Improves up to 15 dB at 500 Hz, 20 dB at 1 kHz to 10 kHz	Dimensions	425 (W) × 112 (H) × 352 (D) mm (16.7 × 4.4 × 13.9 inches)
T.H.D. (Metal)	Less than 0.9%	Weight	5.4 kg (11.9 lbs)
Frequency response			
Normal	25 Hz to 17,000 Hz ±3 dB	Standard accessories	
CrO ₂	25 Hz to 18,000 Hz ±3 dB	Connection cord	× 2
Metal	25 Hz to 20,000 Hz ±3 dB		

* For improvement purposes, specifications and design are subject to change without notice.
 * Noise reduction manufactured under license from Dolby Laboratories Licensing Corporation. "Dolby" and double-D symbol are trade marks of Dolby Laboratories Licensing Corporation.

★ SAFETY INSTRUCTIONS

PRECAUTIONS DURING SERVICING

1. Parts identified by the Δ (*) symbol parts are critical for safety. Replace only with parts number specified.
2. In addition to safety, other parts and assemblies are specified for conformance with such regulations as those applying to spurious radiation.
These must also be replaced only with specified replacements.
Examples: RF converters, tuner units, antenna selector switches, RF cables, noise blocking capacitors, noise blocking filters, etc.
3. Use specified internal wiring. Note especially:
 - 1) Wires covered with PVC tubing
 - 2) Double insulated wires
 - 3) High voltage leads
4. Use specified insulating materials for hazardous live parts. Note especially:
 - 1) Insulation Tape
 - 2) PVC tubing
 - 3) Spacers (Insulating Barriers)
 - 4) Insulation sheets for transistors
 - 5) Plastic screws for fixing microswitch (especially in turntable)
5. When replacing AC primary side components (transformers, power cords, noise blocking capacitors, etc.), wrap ends of wires securely about the terminals before soldering.

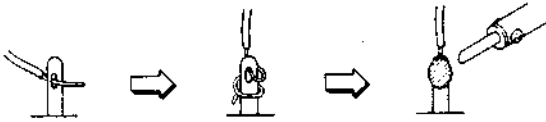

6. Observe that wires do not contact heat producing parts (heatsinks, oxide metal film resistors, fusible resistors, etc.).

7. Check that replaced wires do not contact sharp edged or pointed parts.
8. Also check areas surrounding repaired locations.
9. Use care that foreign objects (screws, solder droplets, etc.) do not remain inside the set.

SAFETY CHECK AFTER SERVICING

Confirm the specified insulation resistance between power cord plug prongs and externally exposed parts of the set is greater than 10 M ohms, but for equipment with external antenna terminals (tuner, receiver, etc.) and is intended for C or A, specified insulation resistance should be headphone jacks line-in-out jacks etc. more than 2.2 M ohms (ground terminals, microphone jacks).

★ INFORMATION

SYMBOLS FOR PRIMARY DESTINATION

Alphabet indicates the destination of the units as listed below.

Symbols	Principal Destinations
A	USA
B	UK
C	Canada
E	Europe (except UK)
J	Japan
S	Australia
V	W. Germany only
U	Universal Area
Y	Custom version

VOLTAGE CONVERSION (U Model only)

Before connecting the power cord, SET the VOLTAGE SELECTOR located on the rear panel with a screwdriver so that the correct voltage is indicated.

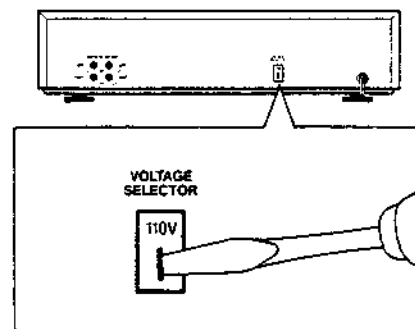

I. CONTROLS

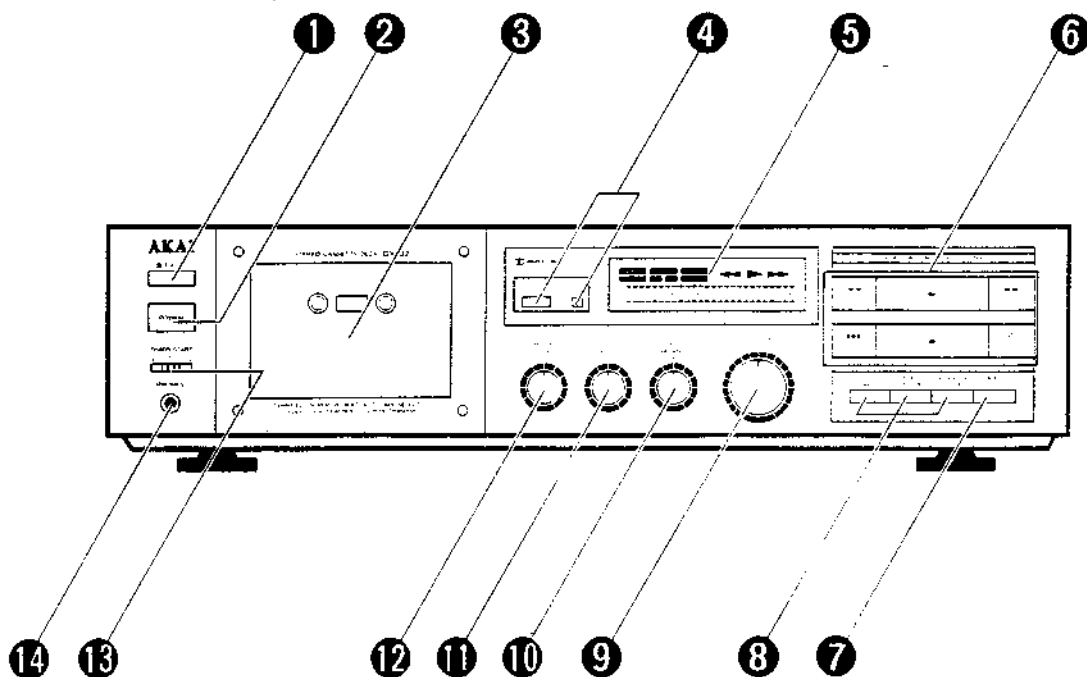

① **EJECT Button**
To open the cassette holder.

② **POWER Button**
To turn the power on and off.

③ **Cassette Holder and Lid**
Load a cassette tape here.

④ **Tape COUNTER and RESET Button**
Tells you how much tape has run during playback or recording. Use the RESET button to reset the tape COUNTER to "000".

⑤ **FL (Fluorescent) Display**
Tells you what the cassette deck is doing.

⑥ **Operation Buttons** (◀◀: Rewind button, ▶: Play button, ▶▶: Fast forward button, ⏸: REC PAUSE button, ■: STOP button, ○: AUTO MUTE button)
For recording, playback and tape winding operations.

⑦ **MPX FILTER Switch**
To turn the multiplex filter on and off.

⑧ **Noise Reduction Selector (NR OFF, DOLBY B-TYPE, DOLBY C-TYPE)**
To select the noise reduction system for recording and playback purposes.

⑨ **REC LEVEL Control**
To set the recording input level. Right and left channel levels are adjusted equally.

⑩ **REC BALANCE Control**
To set the recording level balance of the left and right channels. Set the control to its center click position for stereo recording.

⑪ **BIAS Control**
To set the recording bias current. The bias adjustment range is between -20% and +20% of the proper bias current for Normal and CrO₂ position tapes. Normally set the control to the center click "0" position.

⑫ **PHONES LEVEL Control**
To adjust the output level of the PHONES jack.

⑬ **TIMER START Switch (REC/OFF/PLAY)**
To select operation of the timer start function when the power is turned on.

⑭ **PHONES Jack**
For headphone connection.

FL (Fluorescent) Display

FILTER and Dolby B and C indicators

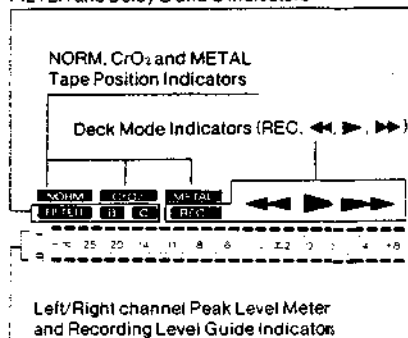

Left/Right channel Peak Level Meter and Recording Level Guide Indicators

II. DISASSEMBLY

In case of trouble, etc. necessitating dismantling, please dismantle in the order shown in the photographs. Reassemble in reverse order.

1. Removal of UPPER COVER

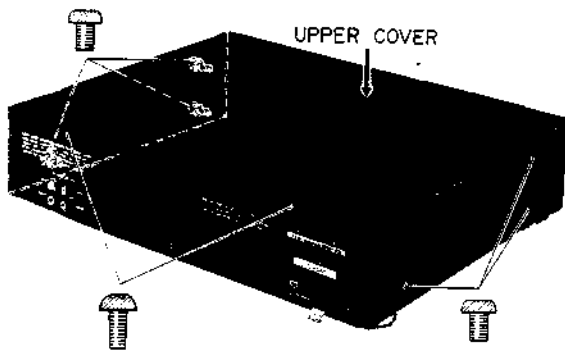

2. Removal of LID PANEL and FRONT PANEL

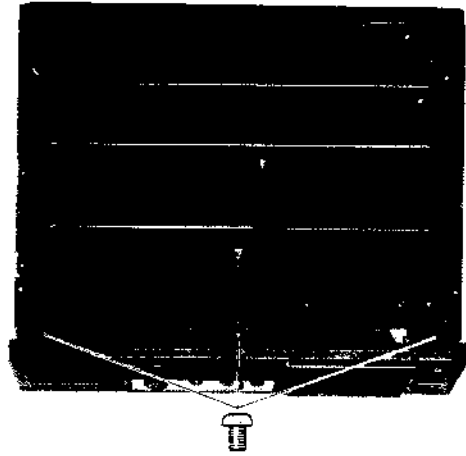

3.

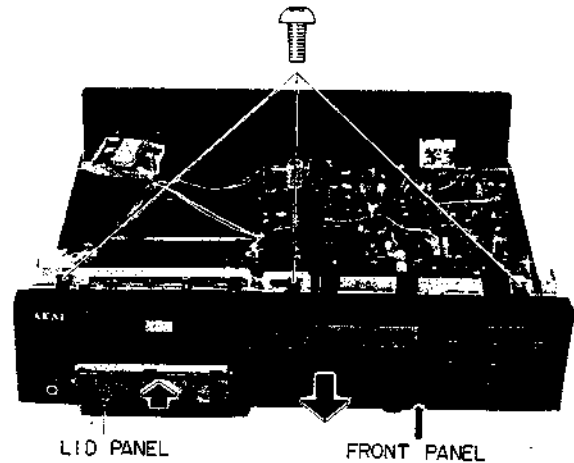

X REMOVE THE CASSETTE LID, THEN REMOVE FRONT PANEL.

III. PRINCIPAL PARTS LOCATION

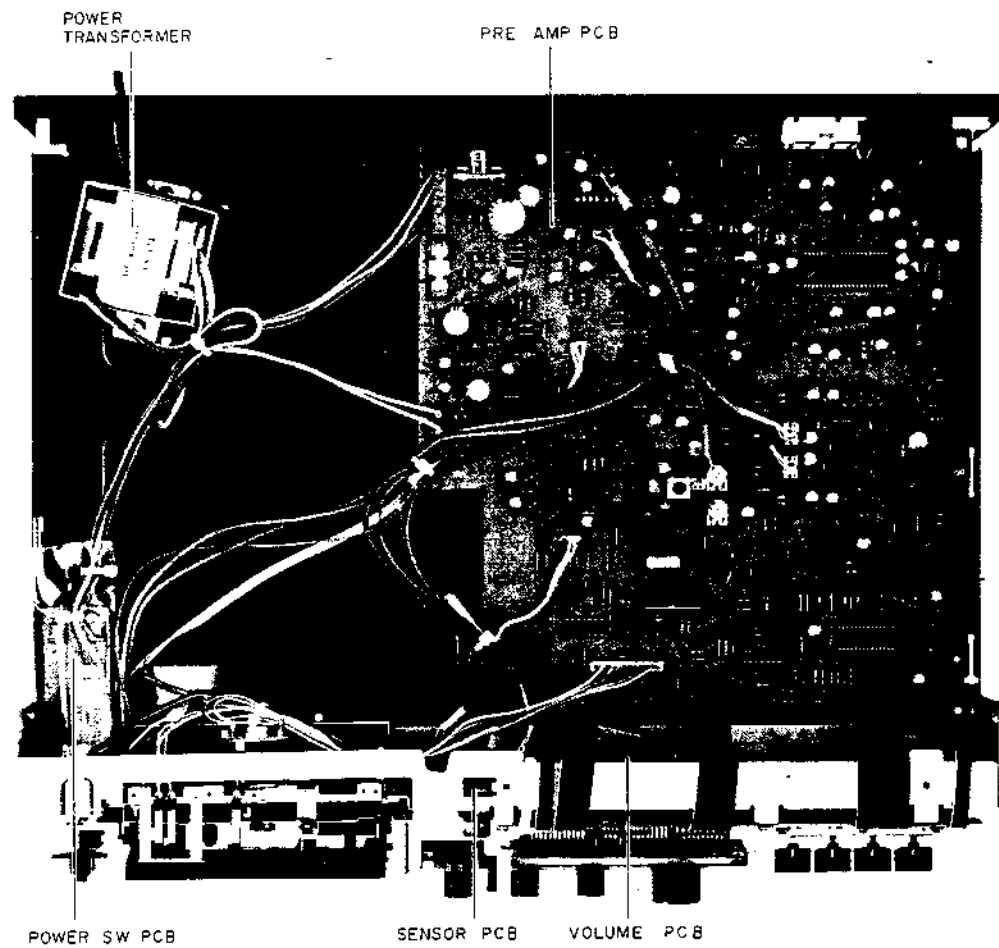

Fig. 3-1. Top View

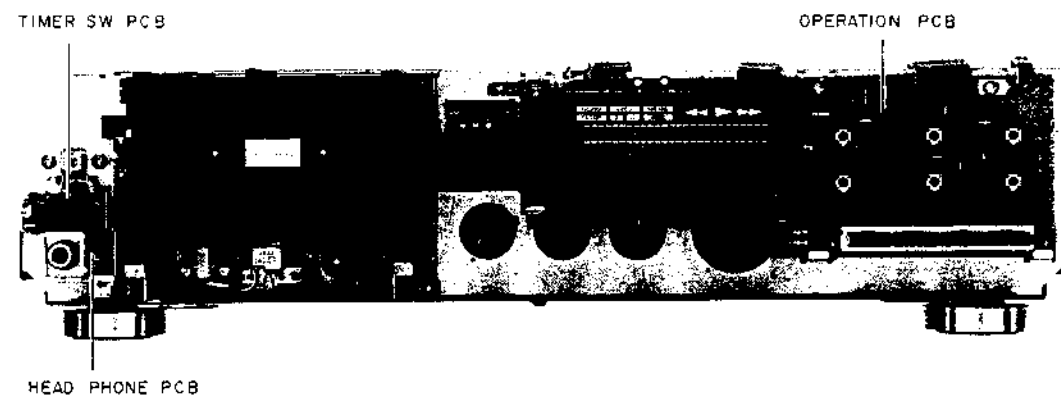

Fig. 3-2. Front View

IV. MECHANICAL ADJUSTMENT

4-1. ADJUSTMENT OF REC/PB HEAD AZIMUTH ALIGNMENT

- 1) Connect AC milli-volt meter and oscilloscope to LINE OUT of LEFT and RIGHT channels.
- 2) Play back a 10 kHz, -15 dB Test Tape (AT-750778) and adjust SCREW (A) so that the waveforms on the oscilloscope are in the same phase at maximum output level.

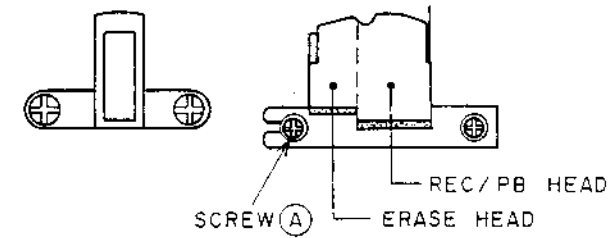

Fig. 4-1

4-2. TAPE SPEED ADJUSTMENT

- 1) Connect a frequency counter to LINE OUT.
- 2) Play back a 3.150 Hz, 0 dB Test Tape (AT-751263), and adjust TAPE SPEED CONTROL in the CAPSTAN MOTOR so that the reading on the Frequency counter is 3.150 ± 5 Hz.

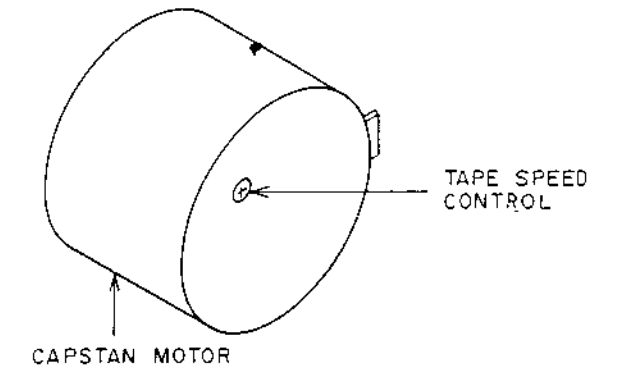

Fig. 4-2

V. ELECTRICAL ADJUSTMENTS

NOTE 1. All adjustments are adjusted without DOLBY, and MPX FILTER.
2. Use the following cassette measuring tape.

NORMAL Tape : MAXELL UD-I C-60
CrO₂ Tape : TDK SA C-60
METAL Tape : TDK MA C-60

STEP	ADJUSTMENT ITEM
1.	Test Tape/Input Signal
2.	Mode
3.	Adjustment Part
4.	Result and Remarks

ADJ. Part →

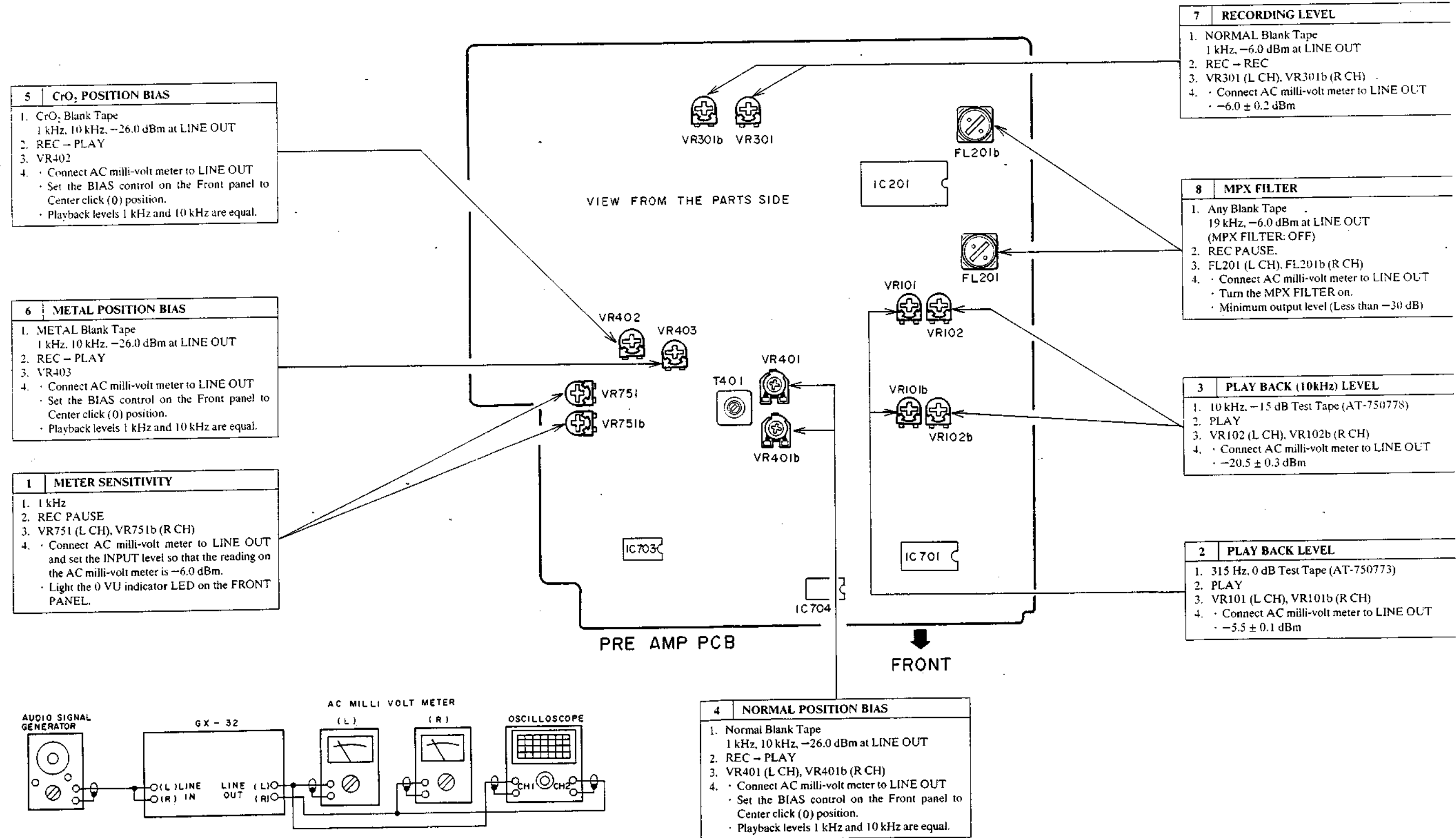

Fig. 5-1 INSTRUMENTS CONNECTION

VI. PARTS LIST

ATTENTION

1. When placing an order for parts, be sure to list Part No., Model No. and the description of each part. Otherwise, the non-delivery of the part or the delivery of a wrong part may result.
2. Please make sure that Part No. is correct when ordering. If not, a part different from the one you ordered may be delivered.
3. Since the parts shown in Parts List of Preliminary Service Manual may have been the subject of changes, please use this Parts List for all future reference.

HOW TO USE THIS PARTS LIST

1. This Parts List lists those parts which are considered necessary for repairs. Other common parts, such as resistors and capacitors, are listed in the "Common List for Service Parts" from which these parts should be selected and stocked.
2. The Recommended Spare Parts List shows those parts in the Parts List which are considered particularly important for service.
3. Parts not shown in the Parts List and "Common List for Service Parts" will not in principle be supplied.
4. How to read the Parts List.

a) Mechanism Block

b) PC Board

2. HEAD BASE BLOCK

REF. NO.	PART NO.	DESCRIPTION
2-1x	BH-T2023A320A	HEAD BASE BLOCK
2-2	HP-H2206A010A	HEAD R/P PR4-8FU C
2-3	ZS-477876	PAN20x03STL CMT
2-4	ZS-536488	BID20x08STL CMT
2-5	ZG-402895	SP CS ANGLE ADJUST

- SP (Service Parts) Classification
- A small "x" indicates that this part is not shown in the Photo or Illustration.
- This number corresponds with the individual parts index number in that figure.
- This number corresponds with the Figure Number.

6. MAIN PC BOARD

REF. NO.	PART NO.	DESCRIPTION
6-IC1	EI-324536	IC HD14049BP
6-IC2	EI-336801	IC MB8841-564M
6-C1A	EC-338399	C MMY V 223M 250AC [U,E,B,S]
6-C1B	EC-350949	C MMY V 223M 250DC [J]
6-C1C	EC-338397	C MMY V 223M 125AC [C,A]
6-X1	EI-318384	OSC X'TAL NC-18C

- Symbols for primary destination
- [A]: AAL(U.S.A.) [S]: SAA(Australia)
- [B]: BEAB(England) [U]: U/T(Universal Area)
- [C]: CSA(Canada) [V]: VDE(W. Germany)
- [E]: CEE(Europe) [Y]: Custom Version
- [J]: JPN(Japan)
- SP (Service Parts) Classification
- These reference symbols correspond with component symbols in the Schematic Diagrams.

The available PC Board Blocks are listed separately.

5. When Part No. is known, Parts Index at end of Parts List can be used to locate where that part is shown in Parts List by its Reference No. listed at right of Part No.

WARNING

△ (*) INDICATES SAFETY CRITICAL COMPONENTS. FOR CONTINUED SAFETY, REPLACE SAFETY CRITICAL COMPONENTS ONLY WITH MANUFACTURE'S RECOMMENDED PARTS.

AVERTISSEMENT

△ (*) IL INDIQUE LES COMPOSANTS CRITIQUES DE SÉCURITÉ. POUR MAINTENIR LE DEGRÉ DE SÉCURITÉ DE L'APPAREIL, NE REMPLACER QUE DES PIÈCES RECOMMANDÉES PAR LE FABRICANT.

1. RECOMMENDED SPARE PARTS

Ref. No.	Part No.	Description
1	BB-T2108A050A	MECHA BLK GX-32 [INCL. 1 TO 90]
2	BF-725588J	FLYWHEEL ASSY (J)
3	BL-715968	PINCH ROLLER ASSY(R)
4	BM-718512	MOTOR BLK W/GEAR RFS 10T-12620 [REEL MOTOR]
5	BM-725446J	MOTOR BLK W/PULLEY EG500AD-2B [CAPSTAN MOTOR]
6	*BT-379933J	TRANS POW T2108(A,C) [A,C] [T901]
7	*BT-379936J	TRANS POW T2108(B) [B] [T901]
8	*BT-379935J	TRANS POW T2108(E) [E] [T901]
9.	*BT-379932J	TRANS POW T2108(U) [U] [T901]
10	ED-307572	D SILICON H 1S5131
11	ED-624903	D SILICON H 1S2473
12	ED-330622	D SILICON 1SR35A-100 100/1.0A
13	*ED-346618	D ZENER H HZ15 1
14	*ED-346599	D ZENER H HZ4 C3
15	ED-337265	D ZENER H HZ6 C2
16	*ED-331667	D ZENER H HZ7 A1
17	*ED-378763J	D ZENER V HZ15LS7 3
18	*ED-348002	D ZENER V HZ2B-2S7
19	*EF-355226	FUSE BET T 250V 1.00A [B]
20	*EF-358974	FUSE BET T 250V 630MA [B]
21	*EF-623103	FUSE SEMKO T 250V 1.00A [E]
22	*EF-601942	FUSE SEMKO T 250V 630MA [E]
23	*EF-309387	FUSE TSC A 250V 1.00A [U]
24	*EF-306124	FUSE TSC A 250V 630MA [U]
25	*EF-310229	FUSE TSC 125V 1.00A [A,C]
26	*EF-305703	FUSE TSC 125V 630MA [A,C]
27	EH-370972	FILTER LC LP 370972
28	*EI-330352	IC BA6109
29	EI-359985	IC CX20187
30	EI-356327	IC HA12067NT
31	EI-337013	IC LB1290
32	EI-353867	IC LC4077B
33	EI-358774	IC LM6413E-542
34	EI-357498	IC M51143AL
35	EI-346071	IC M5218L-21
36	EI-348785	IC M5220L
37	EI-306726	IC TC4069UBP
38	EM-379954J	IND FL FIP26AW15YS
39	EP-715946	SOLENOID SS-066-701C
40	*ER-348272	R FUSE H S10 ERD2FC 1/4W 12ROG
41	*ER-349424	R FUSE H S10 ERD2FC 1/4W 18ROG
42	ES-725367J	SW LEAF LSA1120YN
43	ES-725366J	SW LEAF MSW1537-N
44	ES-373380	SW PUSH ESB-68630 4 THROW N [DOLBY NR]
45	*ES-377828J	SW PUSH ES88296V 01-1 [POWER SW]
46	*ES-359606	SW SELECTOR JUH1420-0201 01-4 [U] [SW902]
47	ES-370965	SW SLIDE \$\$\$U02 1-01-03N [TIMER SW]
48	ES-360576	SW TACT SKHHPM [PLAY]
49	ET-378849J	DETECTOR GP1552
50	ET-369248	TR DTA114YS
51	ET-353897	TR DTC114ES
52	ET-354385	TR DTC114YS
53	ET-373485	TR DTC123JS
54	ET-354364	TR DTC143TS
55	ET-354414	TR DTC144ES
56	ET-370310	TR DTC144TS

Ref. No.	Part No.	Description
57	ET-352726	TR 2SA1392 T,U
58	ET-308977	TR 2SC2274K F F05
59	*ET-349272	TR 2SC3242A E,F F05
60	ET-349081	TR 2SC3383 S,T
61	ET-379239	TR 2SD1380 Q,R
62	EV-373387	VR ROTARY RK16312A0 A104X2 [REC LEVEL]
63	EV-373385	VR ROTARY RK1631210 M104 N104 [REC BALANCE]
64	EV-370008	VR ROTARY T2094 8202 [BIAS ADJ]
65	EV-370005	VR ROTARY T2094 2 THROW A503 [HEADPHONE LEVEL]
66	HP-H2507A010A	HEAD COMB EPR4-13TG2
67	MB-715967	BELT CAPSTAN(A)
68	MB-379843J	BELT COUNTER
69	MC-357702	COUNTER MK395-057
70	MI-715949	IDLER ARM ASSY
71	MT-715957	REEL TABLE
72	MZ-715952	GEAR IDLER
73	MZ-725353J	GEAR MOTOR
74	MZ-715962	GEAR PLAY

2. MECHA BLOCK

Ref. No.	Part No.	Description
4	ZG-715954	SP CASSETTE HOLDER
6	MZ-725348J	PROTECTOR SW (B)
8	MZ-725349J	ARM LOCK EJECT
11	SZ-725350J	SHIELD PLATE
14	MZ-725351J	COLLAR SHIFT ARM
15	MZ-725352J	COLLAR LOCK ARM
17	MI-715949	IDLER ARM ASSY
18	MZ-715952	GEAR IDLER
19	MZ-725353J	GEAR MOTOR
20	MZ-725354J	BASE IDLER
21	TC-725355J	GUIDE CASSETTE
22	TC-725356J	GUIDE CASSETTE (L)
23	TC-725357J	GUIDE CASSETTE (R)
24	MT-715957	REEL TABLE
25	HZ-715959	BASE HEAD
26	MZ-715962	GEAR PLAY
27	ML-725358J	ARM PLANGER
28	BF-725588J	FLYWHEEL ASSY (J)
29	ZW-715966	SPACER CAPSTAN
30	MR-725359J	PULLEY MOTOR (A)
31	BL-715968	PINCH ROLLER ASSY(R)
32	ML-715970	STOPPER CASSETTE
33	ML-715971	EJECTOR
34	TC-715976	HOLDER CASSETTE
35	ZG-712816	CLAMP CASSETTE

MECHA BLOCK

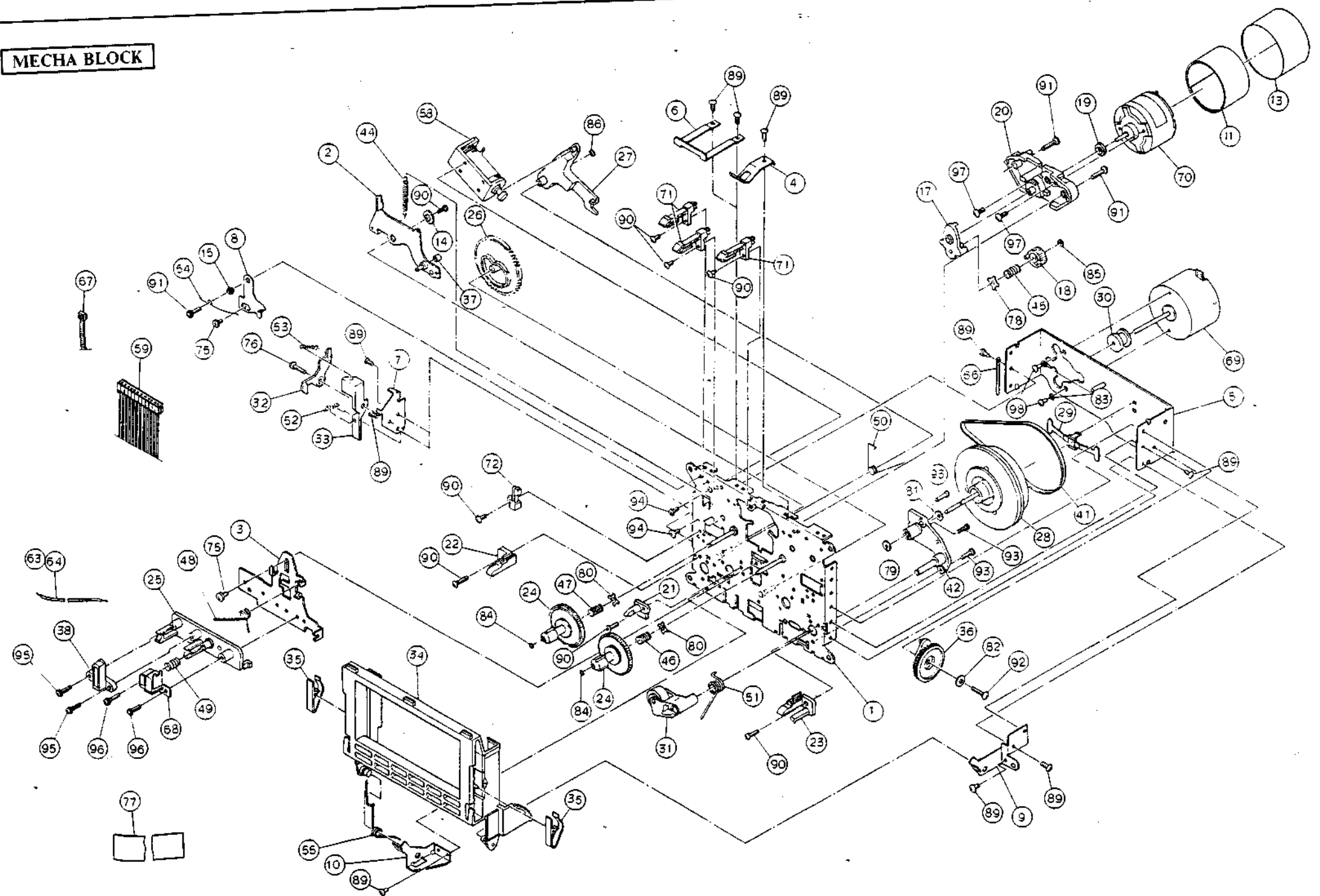

Ref. No.	Part No.	Description	Ref. No.	Part No.	Description	Ref. No.	Part No.	Description
36	TC-715979	DAMPER ASSY	58	EP-715946	SOLENOID SS-066-701C	85	ZW-718513	PW17X035X050PSL
37	MZ-725360J	COLLAR SHIFT ARM	68	HP-H2507A010A	HEAD COMB EPR4-13TG2	86	ZW-725375J	PSW21X040X050
38	MS-715941	TAPE GUIDE	69	BM-725446J	MOTOR BLK W/PULLEY EG500AD-2B [CAPSTAN MOTOR]	90	ZS-725376J	T2PAN20X05
41	MB-715967	BELT CAPSTAN(A)	70	BM-718512	MOTOR BLK W/GEAR RF510T-12620 [REEL MOTOR]	91	ZS-725377J	T2PAN20X08
42	MZ-715947	HOUSING ASSY (R)	71	ES-725366J	SW LEAF MSW1537-N	92	ZS-725378J	T2PAN20X10
44	ZG-725361J	SP SHIFT ARM	72	ES-725367J	SW LEAF LSA1120YN	93	ZS-725379J	T2BID20X04
45	ZG-725362J	SP CLUTCH (B)	75	ZS-725368J	SCREW	95	ZS-725380J	BID20X11
46	ZG-725363J	SP REEL (T)	76	ZS-715982	SCREWB)	96	ZS-725381J	WS PAN20X10
47	ZG-725364J	SP REEL (S)	78	ZW-725589J	PSW16X060X050	97	ZS-725382J	SCREW 26X04
48	ZG-718509	SP HEAD CHASSIS (F)	79	ZW-725370J	WASHER 21X040X050	98	ZS-725383J	PAN26X03
49	ZG-749268	SP HEAD	80	ZW-725371J	WASHER	100	BB-T2108A050A	MECHA BLK GX-32 [INCL 1 TO 98]
50	ZG-715984	SP ARM PL	81	ZW-725370J	WASHER 21X040X050			
51	ZG-715969	SP PINCH ROLLER(R)	82	ZW-725372J	PW			
52	ZG-715973	SP EJECT (A)	83	ZW-725373J	TW28			
53	ZG-715974	SP EJECT (B)	84	ZW-725374J	PSW10X035X050			
54	ZG-725365J	SP LOCK ARM						
55	ZG-715978	SP TORSION						

PARTS LIST

NOTE:
Parts will not be supplied if they are not listed in the parts list, even if they appear on the assembling illustrations with reference No.

3. P.C BOARD BLOCK

Ref. No.	Part No.	Description
1	BA-T2108A020A	PC(##) PRE AMP BLK GX-32

PC(##) PRE-AMP BLK CONSISTS OF FOLLOWING P.C BOARD.

- PRE-AMP P.C BOARD
- OPERATION P.C BOARD
- VR P.C BOARD
- POWER SW P.C BOARD
- HEADPHONE P.C BOARD
- SENSOR P.C BOARD
- TIMER P.C BOARD

4. PRE-AMP P.C BOARD

Ref. No.	Part No.	Description
VR102	EV-356583	R S-FIX H RH0615C 0.10W 332
VR301	EV-358829	R S-FIX H RH0615C 0.10W 223
VR401	EV-330531	R S-FIX H TM8KV2-1S 0.50W503
VR402	EV-356575	R S-FIX H RH0615C 0.10W 222
VR403	EV-356579	R S-FIX H RH0615C 0.10W 102
VR751	EV-356582	R S-FIX H RH0615C 0.10W 473
F1A	*EF-309387	FUSE TSC A 250V 1.00A [U]
F2A	*EF-306124	FUSE TSC A 250V 630MA [U]
F1B	*EF-310229	FUSE TSC 125V 1.00A [A.C]
F2B	*EF-305703	FUSE TSC 125V 630MA [A.C]
F1C	*EF-623103	FUSE SEMKO T 250V 1.00A [E]
F2C	*EF-601942	FUSE SEMKO T 250V 630MA [E]
F1D	*EF-355226	FUSE BET T 250V 1.00A [B]
F2D	*EF-358974	FUSE BET T 250V 630MA [B]

5. OPERATION P.C BOARD

Ref. No.	Part No.	Description
D751	ED-624903	D SILICON H 1S2473
D752	ED-624903	D SILICON H 1S2473
D753	ED-624903	D SILICON H 1S2473
D754	ED-624903	D SILICON H 1S2473
D755	ED-624903	D SILICON H 1S2473
D756	ED-624903	D SILICON H 1S2473
D757	ED-624903	D SILICON H 1S2473
D758	ED-624903	D SILICON H 1S2473
D759	ED-624903	D SILICON H 1S2473
D760	ED-307572	D SILICON H 1S5131
IC751	EI-356327	IC HA12067NT
IC752	EI-337013	IC LB1290
IN701	EM-379954J	IND FL FIP26AW15YS
SW751	ES-373380	SW PUSH ES8-68630 4 THROW N [DOLBY NR]
SW752	ES-360576	SW TACT SKHHPM [PLAY]
SW753	ES-360576	SW TACT SKHHPM [STOP]
SW754	ES-360576	SW TACT SKHHPM [REW]
SW755	ES-360576	SW TACT SKHHPM [FF]
SW756	ES-360576	SW TACT SKHHPM [REC]
SW757	ES-360576	SW TACT SKHHPM [AUTO MUTE]

6. VR P.C BOARD

Ref. No.	Part No.	Description
VR302	EV-373387	VR ROTARY RK16312A0 A104X2 [REC LEVEL]
VR303	EV-373385	VR ROTARY RK1631210 M104 N104 [REC BALANCE]
VR404	EV-370008	VR ROTARY T2094 B202 [BIAS ADJ]
VR601	EV-370005	VR ROTARY T2094 2 THROW A503 [HEADPHONE LEVEL]

7. POWER SW P.C BOARD

Ref. No.	Part No.	Description
C810	*EC-338411	C CE V FZ 103P 400AC
SW801	*ES-377828J	SW PUSH ES88296V 01-1 [POWER SW]

8. HEADPHONE P.C BOARD

Ref. No.	Part No.	Description
J601	EJ-369995	PHONE J 3P HLJ0540-410 GP 6.3 [HEADPHONE]

9. SENSOR P.C BOARD

Ref. No.	Part No.	Description
PH701	ET-378849J	DETECTOR GP1S52

10. TIMER P.C BOARD

Ref. No.	Part No.	Description
SW758	ES-370965	SW SLIDE SSSU02 1-01-03N [TIMER SW]

11. FINAL ASSEMBLY BLOCK

Ref. No.	Part No.	Description
1	SA-379375	FOOT(N)
2	ZS-354055	ST BR30X125TL CMT
3	MC-357702	COUNTER MK395-057
4	MB-379843J	BELT COUNTER
5A	*BT-379932J	TRANS POW T2108(U) [U] [T901]
5B	*BT-379933J	TRANS POW T2108(A,C) [A.C] [T901]

Ref. No.	Part No.	Description
5C	*BT-379935J	TRANS POW T2108(E) [E] [T901]
5D	*BT-379936J	TRANS POW T2108(B) [B] [T901]
6	ZS-313796	ST BID40X06STL CMT
7	*ES-359606	SW SELECTOR JUH1420-0201 01-4 [U] [SW902]
8	ZS-352133	ST BR30X10STL CMT
9A	SP-379937J	PANEL REAR GX-32(U) [U]
9B	SP-379938J	PANEL REAR GX-32(A,C) [A.C]
9C	SP-379939J	PANEL REAR GX-32(E) [E]
9D	SP-379940J	PANEL REAR GX-32(B) [B]
10	ZS-354403	ST BR30X08STL BNI
11	ZS-350934	PT BR30X08STL BNI
12A	*EW-363654	AC CORD 200 0129AVFF B300 A U/ [U]
12B	*EW-363629	AC CORD200 0238ASPT2 B300 A UC [A.C]
12C	*EW-363667	AC CORD 200 0364 LCFL B300 A E [E]
12D	*EW-363679	AC CORD 200 LCFL B300 A B [B]
13A	*SZ-374024J1	INSULATOR TUBE [U.E.B]
13B	*SZ-380876J	INSULATOR TUBE(U,L) [A.C]
14-B	BD-T2108A030A	PANEL FRONT BLK GX-32-B
14-G	BD-T2108A030B	PANEL FRONT BLK GX-32-G
15-B	SE-379847J	ESCUTCHEON(R) B
15-G	SE-379848J	ESCUTCHEON(R) G
16	SZ-379842J	LEVER EJECT
17-B	SK-358066B	KNOB SLIDE-BLACK
17-G	SK-358066E	KNOB SLIDE(G)
18-B	SK-373334A	KNOB VRI(A)-BLACK
18-G	SK-373334B	KNOB VRI(A)-GOLD
19-B	SK-373335A	KNOB VRI(B)-BLACK
19-G	SK-373335B	KNOB VRI(B)-GOLD
20-B	SK-373340A	KNOB PUSH-BLACK
20-G	SK-373340B	KNOB PUSH-GOLD
21-B	SK-373236B	KNOB POWER-B
21-G	SK-373236A	KNOB POWER-G
22-B	SK-379859J	KNOB EJECT B
22-G	SK-379860J	KNOB EJECT G
23-B	SK-373336A	KNOB OPERATION(A) STOP-BLACK
23-G	SK-373336B	KNOB OPERATION(A) STOP-GOLD
24-B	SK-373336C	KNOB OPERATION(A) PLAY-BLACK
24-G	SK-373336D	KNOB OPERATION(A) PLAY-GOLD
25-B	SK-373337A	KNOB OPERATION(B) FF-BLACK
25-G	SK-373337B	KNOB OPERATION(B) FF-GOLD
26-B	SK-373337C	KNOB OPERATION(B) REW-BLACK
26-G	SK-373337D	KNOB OPERATION(B) REW-GOLD
27-B	SK-373337E	KNOB OPERATION(B) PAUSE-BLACK
27-G	SK-373337F	KNOB OPERATION(B) PAUSE-GOLD
28-B	SK-373337G	KNOB OPERATION(B) MUTE B
28-G	SK-373337H	KNOB OPERATION(B) MUTE-GOLD
29	ZS-342001	ST BR30X06STL NI3
30	ZS-305827	ST B1030X06STL BNI
31	TC-379861J	LID DECORATION PLATE
32	ZS-345272	ST BR30X06STL BNI
33	SZ-357722	REFLECTOR
34-B	BD-T2108A040A	LID PANEL BLK GX-32-B
34-G	BD-T2108A040B	LID PANEL BLK GX-32-G
35-B	SP-373343A	COVER UPPER-BLACK
35-G	SP-373343B	COVER UPPER-GOLD
36-B	ZS-341960	ST BID40X06STL BNI
36-G	ZS-341959	ST BID40X06STL NI3

NOTE:

Parts will not be supplied if they are not listed in the parts list, even if they appear on the assembling illustrations with reference No.

FINAL ASSEMBLY BLOCK

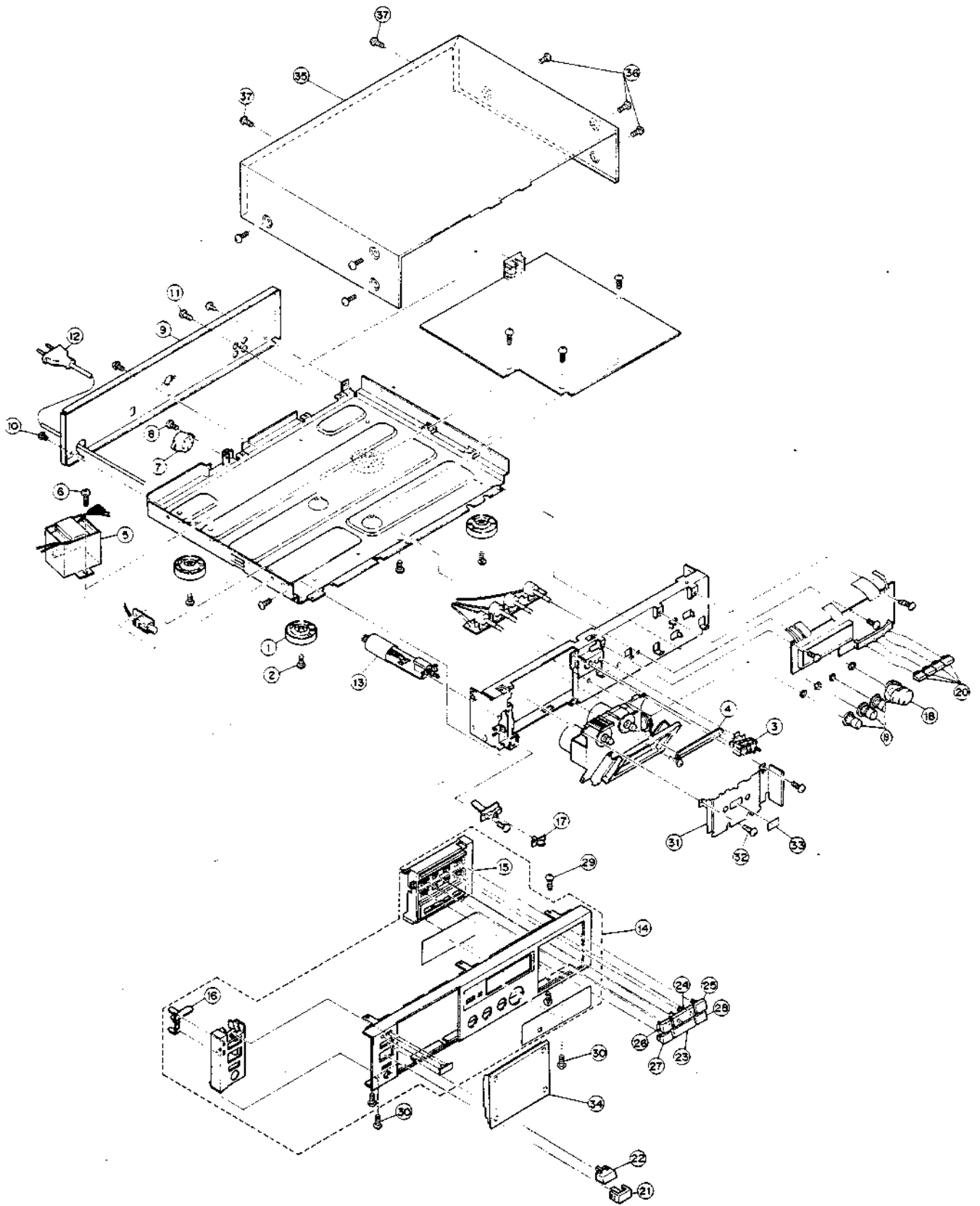

PARTS LIST

INDEX

Part No.	Ref. No.	Part No.	Ref. No.	Part No.	Ref. No.	Part No.	Ref. No.
BA-T2108A020A	3-1	EF-310229	4-F1B	ET-349081	-4-TR304	MI-715949	2-17
BB-T2108A050A	1-1	EF-355226	1-19	ET-349081	4-TR305	ML-715970	2-32
BB-T2108A050A	2-100	EF-355226	4-F1D	ET-349081	4-TR306	ML-715971	2-33
BD-T2108A030A	11-14-B	EF-358974	1-20	ET-349081	4-TR406	ML-725358J	2-27
BD-T2108A030B	11-14-G	EF-358974	4-F2D	ET-349081	4-TR412	MR-725359J	2-30
BD-T2108A040A	11-34-B	EF-601942	1-22	ET-349081	4-TR422	MS-715941	2-38
BD-T2108A040B	11-34-G	EF-601942	4-F2C	ET-349081	4-TR712	MT-715957	1-71
BF-725588J	1-2	EF-623103	1-21	ET-349081	4-TR713	MT-715957	2-24
BF-725588J	2-28	EF-623103	4-F1C	ET-349081	4-TR802	MZ-715947	2-42
BL-715968	1-3	EH-370972	1-27	ET-349081	4-TR804	MZ-715952	1-72
BL-715968	2-31	EH-370972	4-FL201	ET-349272	1-59	MZ-715952	2-18
BM-718512	1-4	EI-306726	1-37	ET-349272	4-TR701	MZ-715962	1-74
BM-718512	2-70	EI-306726	4-IC704	ET-349272	4-TR709	MZ-715962	2-26
BM-725446J	1-5	EI-330352	1-28	ET-349272	4-TR710	MZ-725348J	2-6
BM-725446J	2-69	EI-330352	4-IC702	ET-349272	4-TR722	MZ-725349J	2-8
BT-379932J	1-9	EI-337013	1-31	ET-352726	1-57	MZ-725351J	2-14
BT-379932J	11-5A	EI-337013	5-IC752	ET-352726	4-TR408	MZ-725352J	2-15
BT-379933J	1-6	EI-346071	1-35	ET-352726	4-TR801	MZ-725353J	1-73
BT-379933J	11-5B	EI-346071	4-IC301	ET-353897	1-51	MZ-725353J	2-19
BT-379935J	1-8	EI-346071	4-IC601	ET-353897	4-TR407	MZ-725354J	2-20
BT-379935J	11-5C	EI-348785	1-36	ET-354364	1-54	MZ-725360J	2-37
BT-379936J	1-7	EI-348785	4-IC101	ET-354364	4-TR705	SA-379375	11-1
BT-379936J	11-5D	EI-353867	1-32	ET-354365	1-52	SE-379847J	11-15-B
EC-338411	7-C810	EI-353867	4-IC703	ET-354365	4-TR711	SE-379848J	11-15-G
EC-347247	4-C401	EI-356327	1-30	ET-354365	4-TR721	SK-358066B	11-17-B
ED-307572	1-10	EI-356327	5-IC751	ET-354414	1-55	SK-358066E	11-17-G
ED-307572	4-D703	EI-357498	1-34	ET-354414	4-TR409	SK-373236A	11-21-G
ED-307572	4-D712	EI-357498	4-IC501	ET-354414	4-TR410	SK-373236B	11-21-B
ED-307572	5-D760	EI-358774	1-33	ET-354414	4-TR411	SK-373334A	11-18-B
ED-330622	1-12	EI-358774	4-IC701	ET-354414	4-TR702	SK-373334B	11-18-G
ED-330622	4-D704	EI-359985	1-29	ET-354414	4-TR703	SK-373335A	11-19-B
ED-330622	4-D802	EI-359985	4-IC201	ET-369248	1-50	SK-373335B	11-19-G
ED-330622	4-D803	EJ-336905	4-J101	ET-369248	4-TR706	SK-373336A	11-23-B
ED-330622	4-D804	EJ-369995	8-J601	ET-369248	4-TR707	SK-373336B	11-23-G
ED-330622	4-D805	EM-379954J	1-38	ET-369248	4-TR708	SK-373336C	11-24-B
ED-330622	4-D806	EM-379954J	5-IN701	ET-369248	4-TR715	SK-373336D	11-24-G
ED-330622	4-D810	EO-323982	4-FL301	ET-369248	4-TR716	SK-373337A	11-25-B
ED-330622	4-D811	EO-345881	4-L401	ET-369248	4-TR718	SK-373337B	11-25-G
ED-330622	4-D812	EO-378848J	4-T401	ET-369248	4-TR719	SK-373337C	11-26-B
ED-330622	4-D813	EO-379950J	4-L201	ET-369248	4-TR720	SK-373337D	11-26-G
ED-331667	1-16	EO-379951J	4-L301	ET-370310	1-56	SK-373337E	11-27-B
ED-331667	4-D701	EP-715946	1-39	ET-370310	4-TR404	SK-373337F	11-27-G
ED-331667	4-D809	EP-715946	2-58	ET-370310	4-TR413	SK-373337G	11-28-B
ED-337265	1-15	ER-348272	1-40	ET-373485	1-53	SK-373337H	11-28-G
ED-337265	4-D707	ER-348272	4-FR701	ET-373485	4-TR704	SK-373340A	11-20-B
ED-346599	1-14	ER-349424	1-41	ET-378849J	1-49	SK-373340B	11-20-G
ED-346599	4-D706	ER-349424	4-FR601	ET-378849J	9-PH701	SK-379859J	11-22-B
ED-346618	1-13	ER-379952J	4-R714	ET-379239	1-61	SK-379860J	11-22-G
ED-346618	4-D815	ES-359606	1-46	ET-379239	4-TR405	SP-373343A	11-35-B
ED-348002	1-18	ES-359606	1-17	ET-379239	4-TR803	SP-373343B	11-35-G
ED-348002	4-D801	ES-360576	1-48	ET-379239	4-TR805	SP-379937J	11-9A
ED-378763J	1-17	ES-360576	5-SW752	EV-330531	4-VR401	SP-379938J	11-9B
ED-378763J	4-D814	ES-360576	5-SW753	EV-356575	4-VR402	SP-379939J	11-9C
ED-624903	1-11	ES-360576	5-SW754	EV-356579	4-VR403	SP-379940J	11-9D
ED-624903	4-D401	ES-360576	5-SW755	EV-356581	4-VR101	SZ-357722	11-33
ED-624903	4-D702	ES-360576	5-SW756	EV-356582	4-VR751	SZ-374024J1	11-13A
ED-624903	4-D705	ES-360576	5-SW757	EV-356583	4-VR102	SZ-379842J	11-16
ED-624903	4-D710	ES-370965	1-47	EV-358829	4-VR301	SZ-380876J	11-13B
ED-624903	4-D711	ES-370965	10-SW758	EV-370005	1-65	SZ-725350J	2-11
ED-624903	4-D713	ES-373380	1-44	EV-370005	6-VR601	TC-379861J	11-31
ED-624903	4-D714	ES-373380	5-SW751	EV-370008	1-64	TC-715976	2-34
ED-624903	4-D715	ES-377828J	1-45	EV-370008	6-VR404	TC-715979	2-36
ED-624903	4-D807	ES-377828J	7-SW801	EV-373385	1-63	TC-725355J	2-21
ED-624903	4-D808	ES-725366J	1-43	EV-373385	6-VR303	TC-725356J	2-22
ED-624903	5-D751	ES-725366J	2-71	EV-373387	1-62	TC-725357J	2-23
ED-624903	5-D752	ES-725367J	1-42	EV-373387	6-VR302	ZG-712816	2-35
ED-624903	5-D753	ES-725367J	2-72	EW-363629	11-12B	ZG-715954	2-4
ED-624903	5-D754	ET-308977	1-58	EW-363654	11-12A	ZG-715964	2-50
ED-624903	5-D755	ET-308977	4-TR401	EW-363667	11-12C	ZG-715969	2-51
ED-624903	5-D756	ET-308977	4-TR402	EW-363679	11-12D	ZG-715973	2-52
ED-624903	5-D757	ET-349081	1-80	HP-H2507A010A	1-66	ZG-715974	2-53
ED-624903	5-D758	ET-349081	4-TR101	HP-H2507A010A	2-68	ZG-715978	2-55
ED-624903	5-D759	ET-349081	4-TR102	HZ-715959	2-25	ZG-718509	2-48
EF-305703	1-26	ET-349081	4-TR103	MB-379843J	1-68	ZG-725361J	2-44
EF-305703	4-F2B	ET-349081	4-TR104	MB-379843J	11-4	ZG-725362J	2-45
EF-306124	1-24	ET-349081	4-TR201	MB-715967	1-67	ZG-725363J	2-46
EF-306124	4-F2A	ET-349081	4-TR202	MB-715967	2-41	ZG-725364J	2-47
EF-309387	1-23	ET-349081	4-TR301	MC-357702	1-69	ZG-725365J	2-54
EF-309387	4-F1A	ET-349081	4-TR302	MC-357702	11-3	ZG-749268	2-49
EF-310229	1-25	ET-349081	4-TR303	MI-715949	1-70	ZS-305827	11-30

INDEX

Part No.	Ref. No.	Part No.	Ref. No.	Part No.	Ref. No.	Part No.	Ref. No.
ZS-313796	11-6						
ZS-341959	11-36-G						
ZS-341960	11-36-B						
ZS-342001	11-29						
ZS-345272	11-32						
ZS-350934	11-11						
ZS-352133	11-8						
ZS-354055	11-2						
ZS-354403	11-10						
ZS-715962	2-76						
ZS-725368J	2-75						
ZS-725376J	2-90						
ZS-725377J	2-91						
ZS-725378J	2-92						
ZS-725379J	2-93						
ZS-725380J	2-95						
ZS-725381J	2-96						
ZS-725382J	2-97						
ZS-725383J	2-98						
ZW-715966	2-29						
ZW-718513	2-85						
ZW-725370J	2-79						
ZW-725370J	2-81						
ZW-725371J	2-80						
ZW-725372J	2-82						
ZW-725373J	2-83						
ZW-725374J	2-84						
ZW-725375J	2-86						
ZW-725589J	2-78						

ABBREVIATIONS FOR SERVICE MANUAL (CASSETTE)

Abbreviation	Explanation	Abbreviation	Explanation
AC	Alternating Current	MIN	MINute
A/D	Analog/Digital	MML	Maximum Modulation Level
AF	Auto Fader	MOL	Maximum Output Level
AMP	AMPlifier	MPX	Multi PleX
AR	Anti Recording	NC	Not Connected (No Connection)
AT BIAS	Auto Tuning BIAS	NFB	Negative Feed Back
ATT	ATTenuator	NORM	NORMAl
BAL	BALance	NR	Noise Reduction
BEF	Band Elimination Filter	OSC	OSCillator (OSCillation)
BSS	Blank Search System	P	Pulse
CAP M	CAPsTan Motor	PB	Play Back
CH	CHannel	QMSS	Quick Memory Search System
COMP	COMParator	QR	Quick Reverse
CONT	CONTinuance	R CH	Right CHannel
CRLP	Computer Recording Level Process- ing	REC	RECord (RECording)
CS	Chip Select	REV	REVerse
D/A	Digital/Analog	ROT	ROTation
DC	Direct Current	REW	REWind
DET	DETECTOR	SEC	SECOnd
DISCRI	DISCRIminator	SELE	SELEctor
DUB	DUBbing	SENS	SENSitivity
EQ	EQualizer	SEPP	Single Ended Push Pull
FF(or F.FWD)	Fast Forward	SIG	SIGnal
FLD	FLuorescent Display	SPECT	SPECTrum
FREQ	FREQUency	STD	STANdard
FWD	ForWarD	SW	SWitch
GND	GrouND	SYSCON	SYStem CONtrol
H	High	TP	Test Point
HPF	High Pass Filter	TRIG	TRIGa
IND	INDicator	VCA	Voltage Control Attenuator
IPLS	Instant Program Location System	VOL	VOLume
L	Low	VOLT	VOLTage
L CH	Left CHannel	VR	Variable Resistor
LED	Light Emitting Diode	X'TAL	cysTAL
MEMO	MEMOry	X1	Normal speed
MICOM	MicroCOMputer	X2	Dubble speed

AKAI ELECTRIC CO., LTD.

12-14, 2-Chome, Higashi-Kojiya, Ohta-Ku, Tokyo, Japan
SERVICE DEPARTMENT TEL: Tokyo(745)9884 TELEX: J26261

Printed No. 880310-11-2500

Printed Date: March 30, 1988
350 Printed in Japan

AKAI

MODEL GX-32

SCHEMATIC DIAGRAM AND PC BOARDS

TABLE OF CONTENTS

1. ICs	2
2. BLOCK DIAGRAM	3
3. SCHEMATIC DIAGRAM	4
4. PRE AMP PC BOARD.....	5
5. OTHER PC BOARDS	6

HA12067 (2 CHANNEL 12 POINT BAR DISPLAY DRIVER)

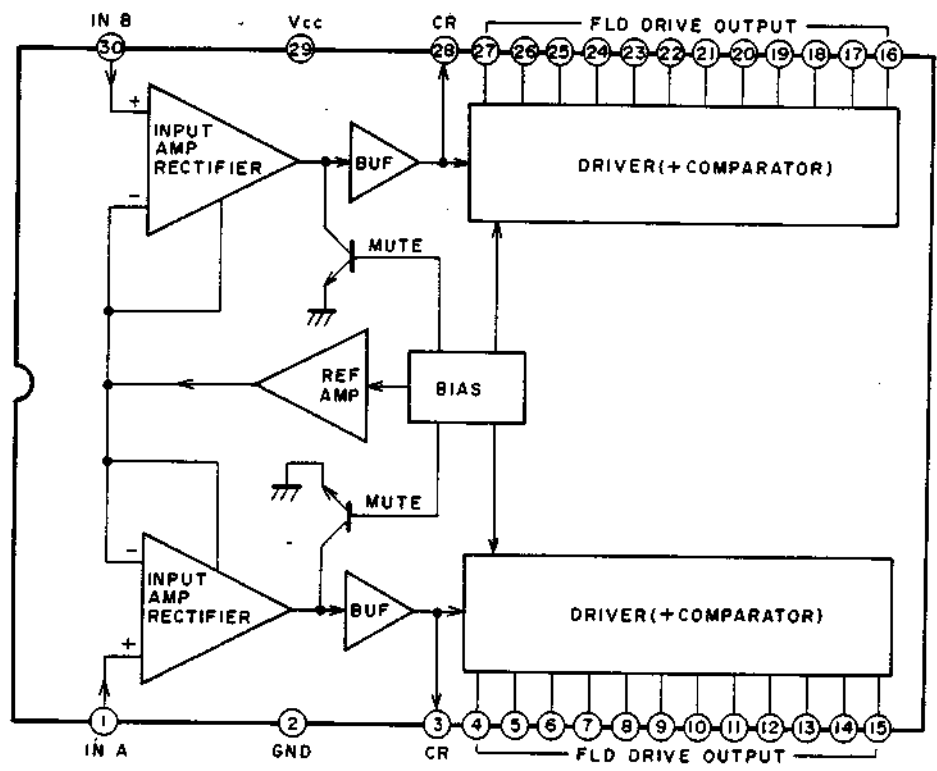

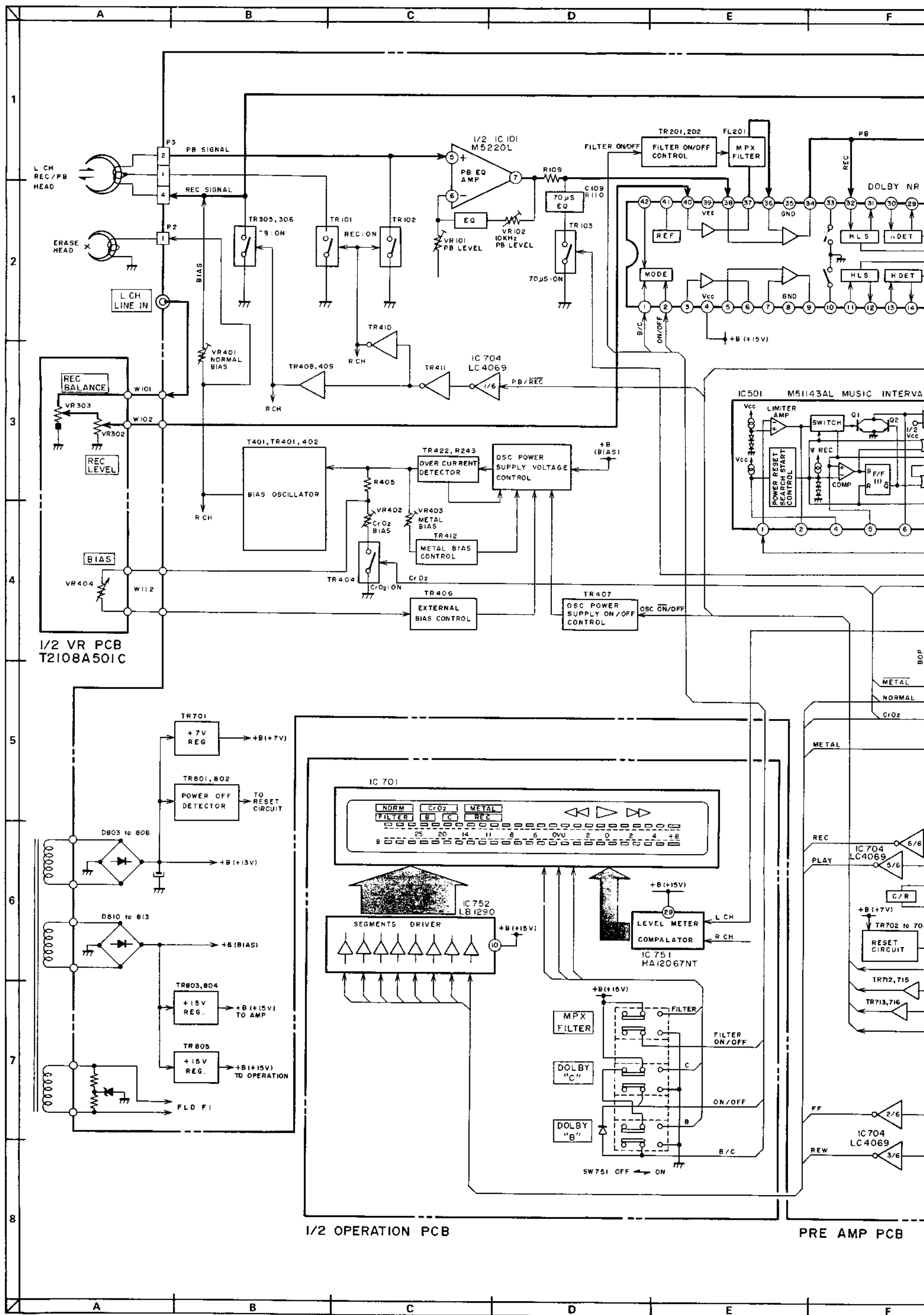

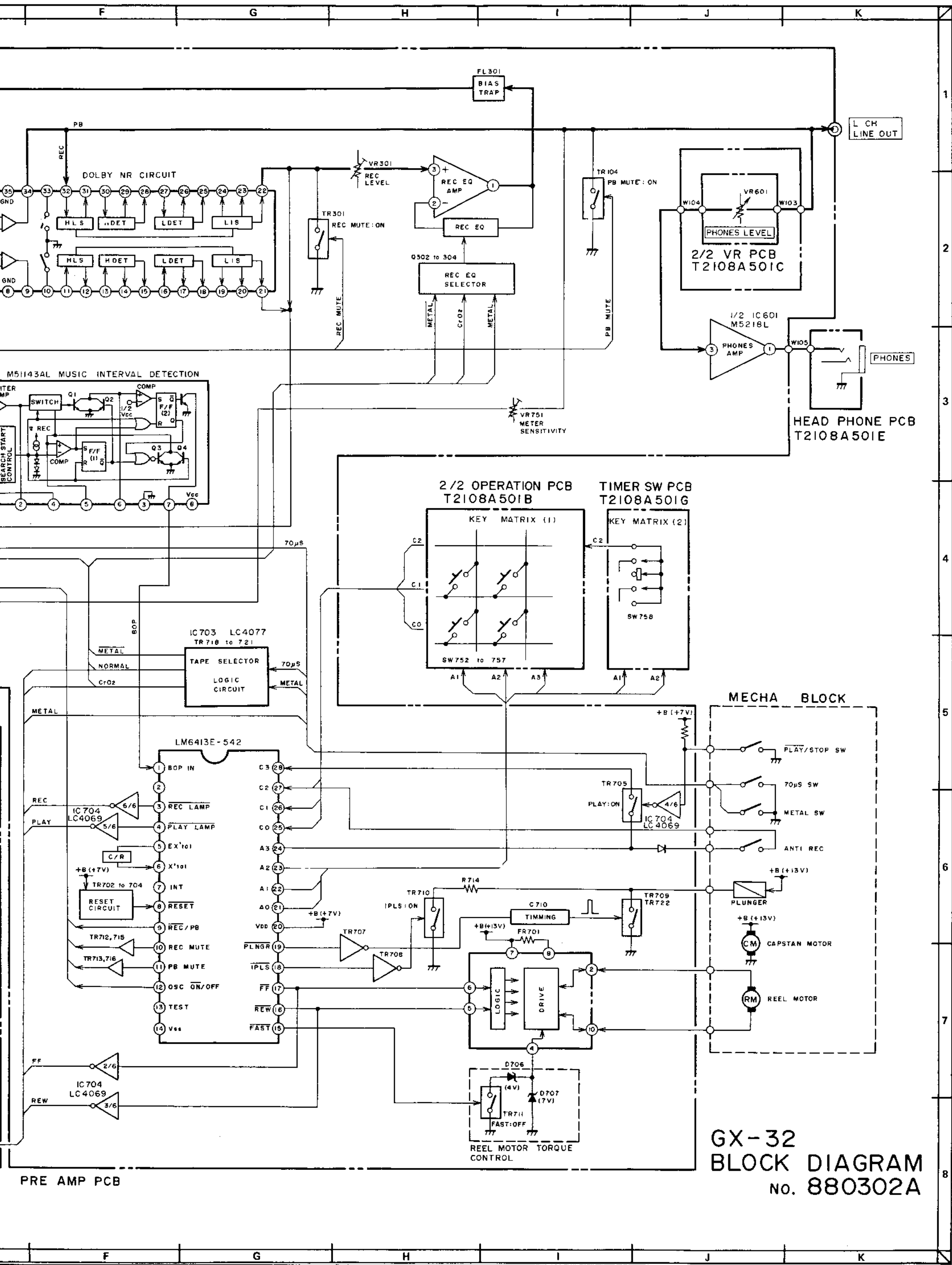

GX-32
BLOCK DIAGRAM
 No. 880302A

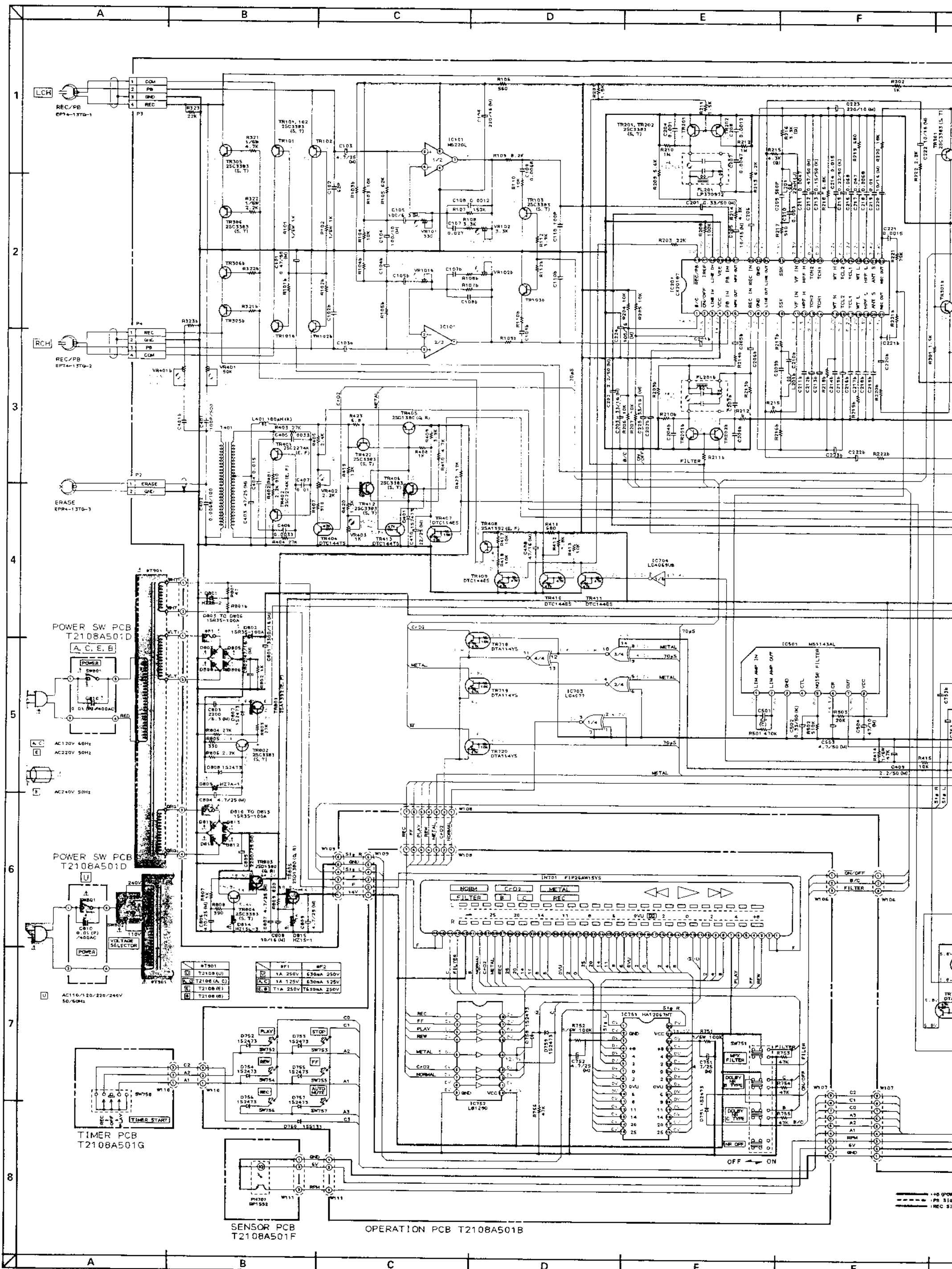

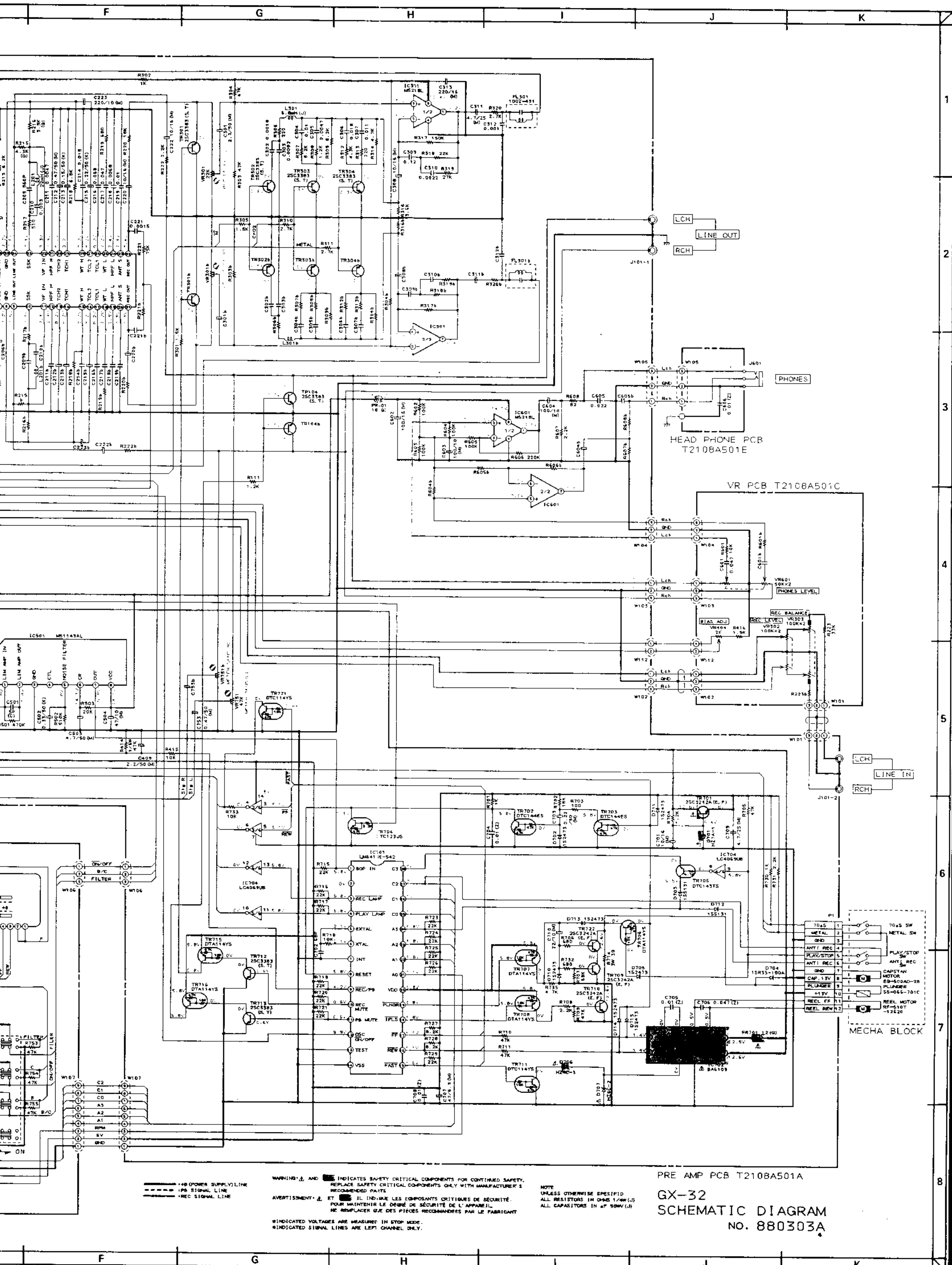

-+ (POWER SUPPLY) LINE
 - (SIGNAL) LINE
 - (REC SIGNAL) LINE

WARNING: ⚠ AND ■ INDICATES SAFETY CRITICAL COMPONENTS FOR CONTINUED SAFETY.
 REPLACE SAFETY CRITICAL COMPONENTS ONLY WITH MANUFACTURER'S RECOMMENDED PARTS.
 AVERTISSEMENT: ⚠ ET ■ INDIQUE LES COMPOSANTS CRITIQUES DE SECURITE.
 POUR MAINTENIR LE DEGRE DE SECURITE DE L'APPAREIL, NE REMPLACER QUE DES PIECES RECOMMENDEES PAR LE FABRICANT.

■ INDICATED VOLTAGES ARE MEASURED IN STOP MODE.
 ■ INDICATED SIGNAL LINES ARE LEFT CHANNEL ONLY.

NOTE
 UNLESS OTHERWISE SPECIFIED
 ALL RESISTORS IN OHMS 1/4W (1/2)
 ALL CAPACITORS IN μF 50V (1/2)

PRE AMP PCB T2108A501A
 GX-32
 SCHEMATIC DIAGRAM
 NO. 880303A

MECHA BLOCK

- 706S SW
- METAL SW
- ANT REC 4
- PLAY/STOP SW
- ANT REC 6
- CAPSTAN MOTOR EQ-800AD-2B
- PLUNGER SS-065-701C
- REEL FF 11
- REEL REV 12

C	IC101	E5	TR303	F3	TR711	C4
IC201	E5	TR303b	F4	TR712	C5	
IC301	E5	TR304	G3	TR713	D4	
IC501	F4	TR304b	G4	TR715	D5	
IC601	H2	TR401	E3	TR716	D4	
IC701	E6	TR402	E3	TR718	D2	
C702	C3	TR404	F2	TR719	D2	
C703	C2	TR405	D3	TR720	C2	
C704	C4	TR406	E2	TR721	C6	
		TR407	E2	TR722	J3	
TRANSISTOR		TR408	D5	TR801	H2	
TR201	E5	TR409	D5	TR803	H2	
TR201b	D5	TR410	D6	TR804	H2	
TR202	F5	TR411	D6	TR805	C2	
TR202b	D5	TR412	E3			
TR203	E5	TR413	E2	CONNECTOR		
TR204	F4	TR422	D3	B1	C4	
TR204b	F4	TR701	F1	B2	C4	
TR201	F3	TR702	D6	B3	C4	
TR201b	F6	TR704	D5	B4	C4	
TR202	F6	TR705	D6	B5	C4	
TR202b	F6	TR706	C4	B6	C4	
TR301	H3	TR707	C4	B7	C4	
TR301b	H4	TR708	C5	B8	C4	
TR302	C3	TR709	D3	B9	C4	
TR302b	C4	TR710	D4	B10	C4	

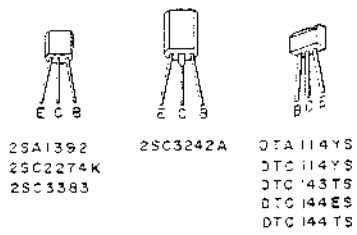
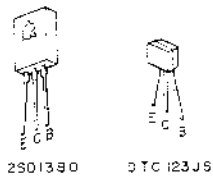

••••• = NPN TRANSISTOR
 ••••• = PNP TRANSISTOR

WARNING: Δ INDICATES SAFETY CRITICAL COMPONENTS FOR CONTINUED SAFETY. REPLACE SAFETY CRITICAL COMPONENTS ONLY WITH MANUFACTURER'S RECOMMENDED PARTS.
 AVERTISSEMENT: Δ IL INDIQUE LES COMPOSANTS CRITIQUES DE SÉCURITÉ. POUR MAINTENIR LE DEGRÉ DE SÉCURITÉ DE L'APPAREIL, NE REMPLACER QUE DES PIÈCES RECOMMANDÉES PAR LE FABRICANT.

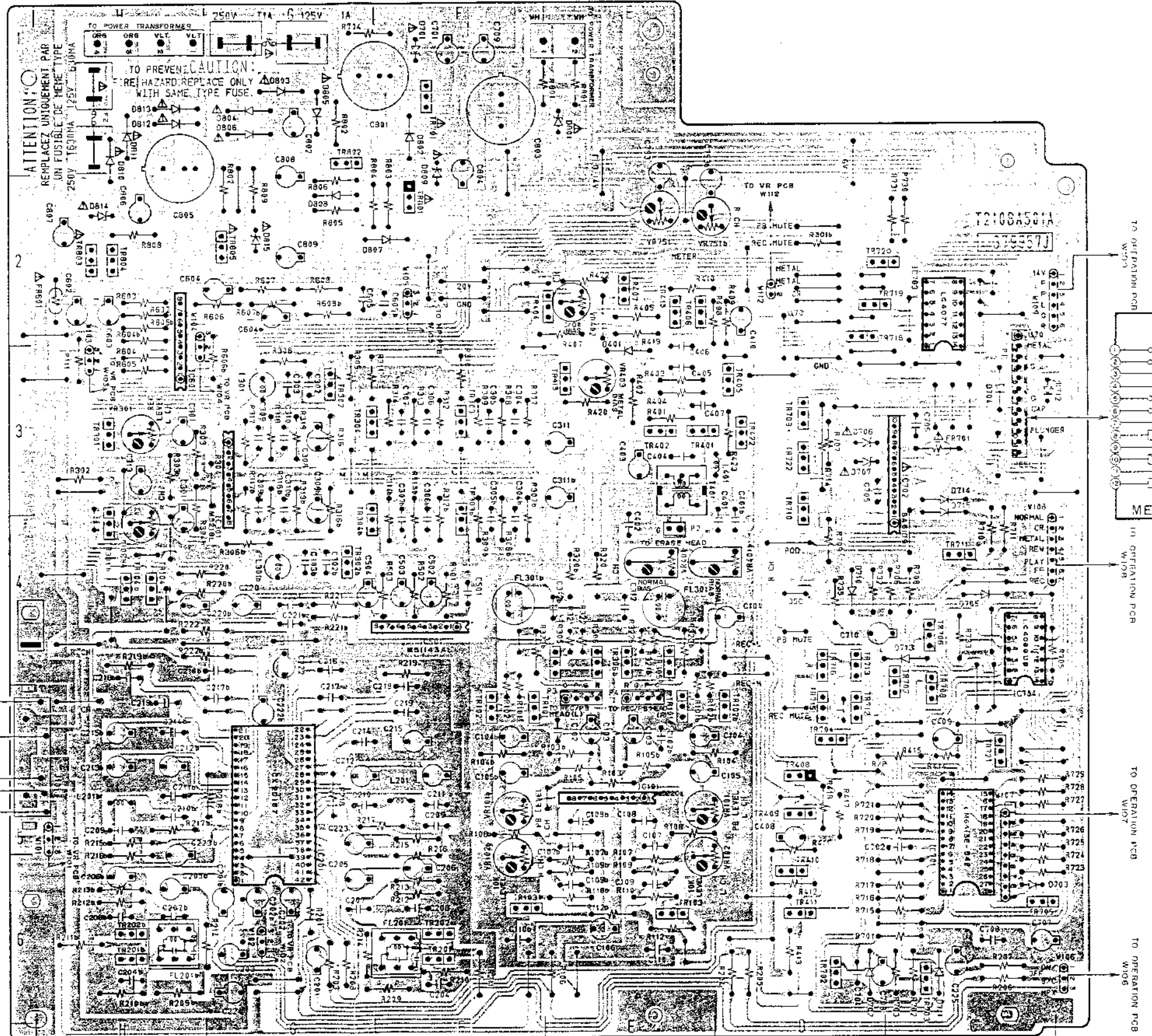
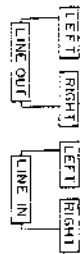

PRE AMP PCB T2108A501A

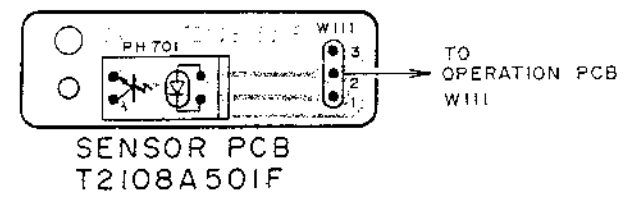
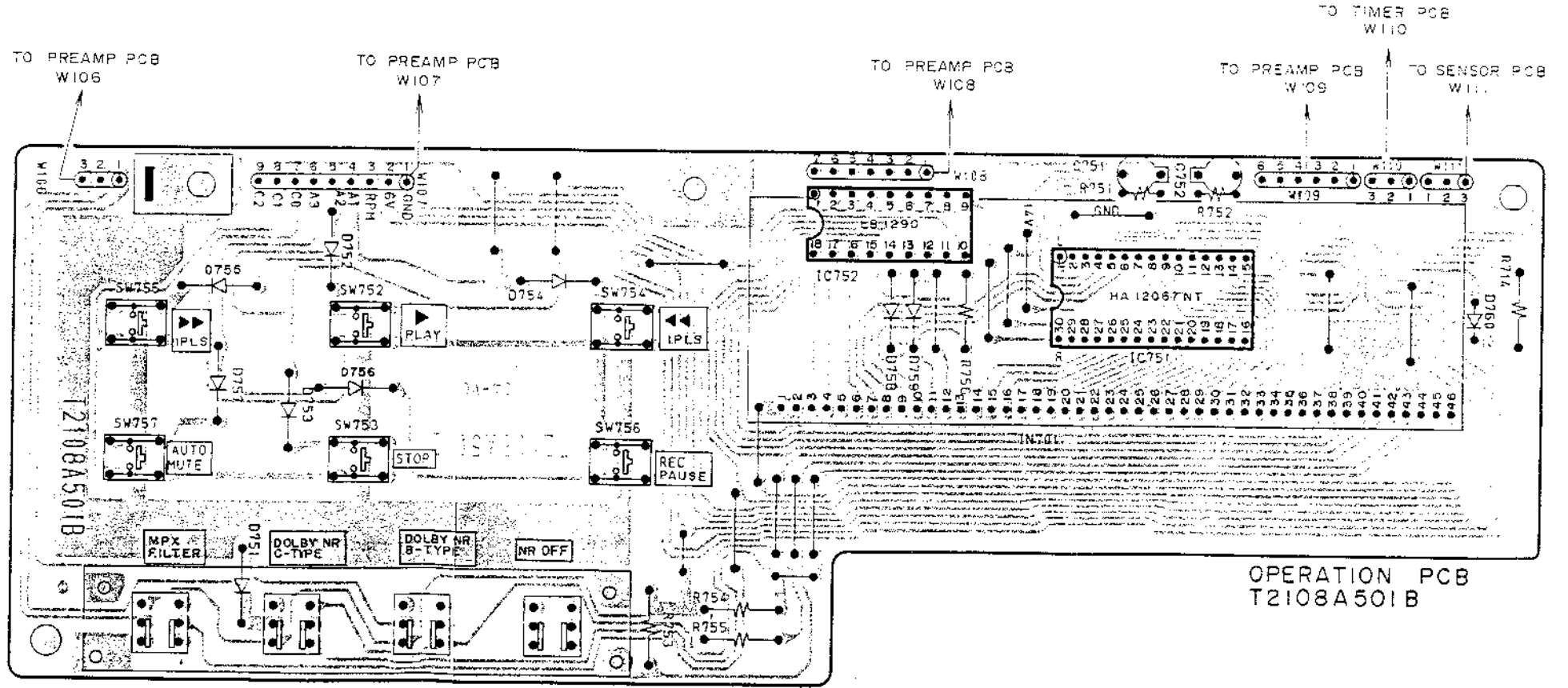
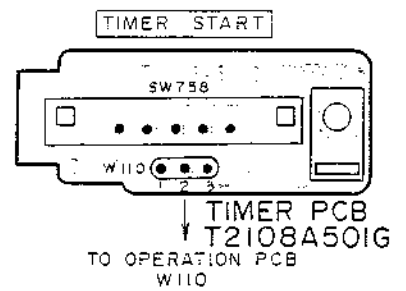
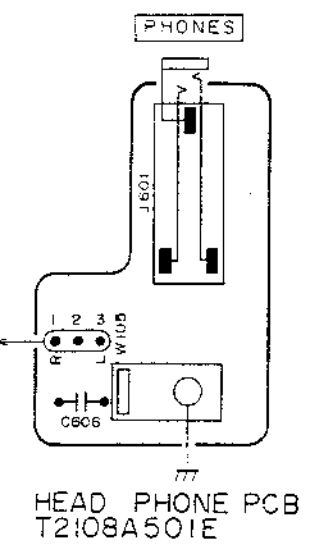
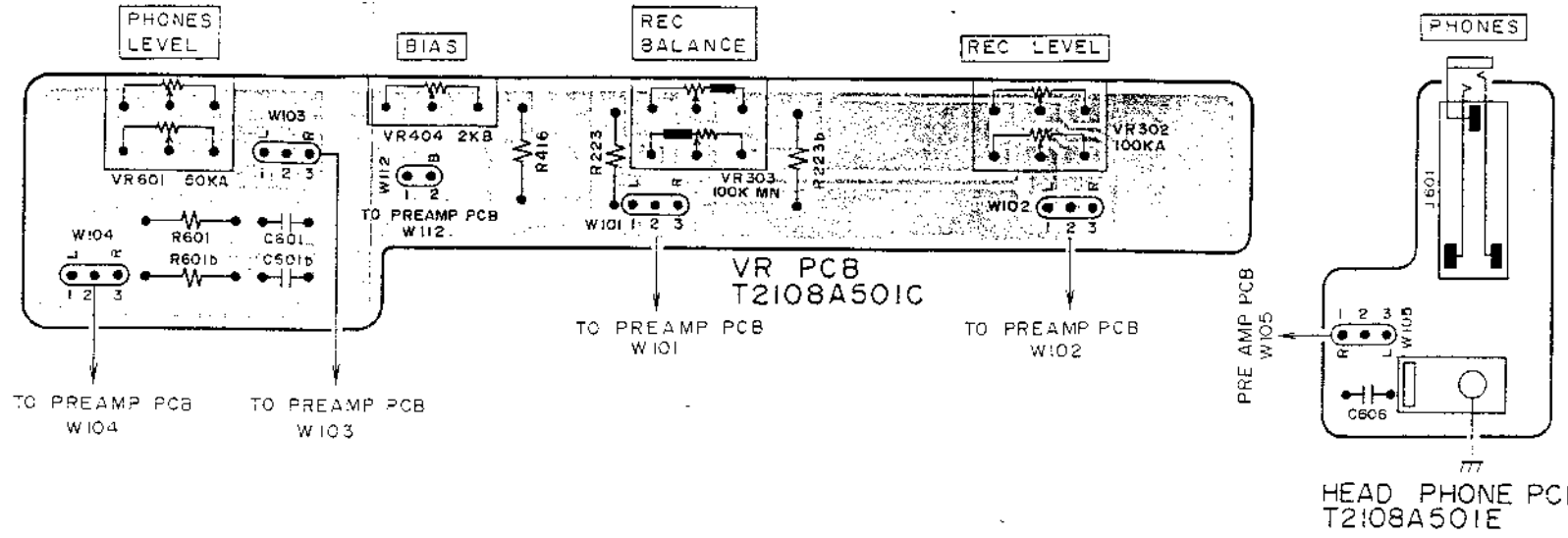
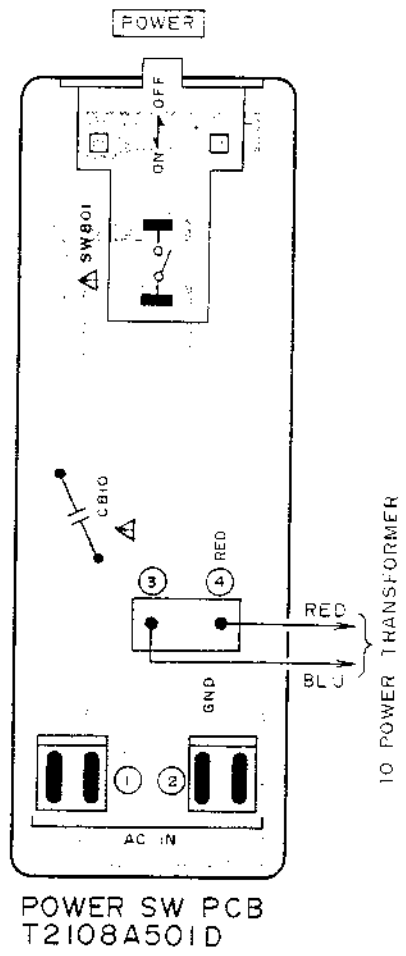

WARNING Δ INDICATES SAFETY CRITICAL COMPONENTS FOR CONTINUED SAFETY.
REPLACE SAFETY CRITICAL COMPONENTS ONLY WITH MANUFACTURER'S
RECOMMENDED PARTS.

AVERTISSEMENT Δ IL INDIQUE LES COMPOSANTS CRITIQUES DE SÉCURITÉ.
POUR MAINTENIR LE DEGRÉ DE SÉCURITÉ DE L'APPAREIL
NE REMPLACER QUE DES PIÈCES RECOMMANDÉES PAR LE FABRICANT.