



Service Manual

Nakamichi MR-1

Discrete Head
Professional Cassette Deck

CONTENTS

1. General	2
2. Test Tapes and Gauges	2
3. Mechanical Adjustments	2
3.1. Record Head and Playback Head Tilt Adjustment	2
3.2. Head Base Stroke Check	3
3.3. Erase Head Stroke Adjustment and Tape Guide Height Check	4
3.4. Erase Head Height and Tilt Adjustment	4
3.5. Playback Head and Record Head Height Adjustment and Azimuth Alignment	5
3.6. Pressure Adjustment of Take-up Pressure Roller	6
3.7. Tape Travelling Check	6
3.8. Eject Damper Adjustment	6
3.9. Reel Motor Speed Adjustment in Play Mode	6
3.10. Tape Speed Adjustment	7
3.11. Lubrication	7
4. Parts Location for Electrical Adjustment	8
5. Electrical Adjustments	9
5.1. Adjustment Instructions	9
5.2. Playback Frequency Response Adjustment	12
6. Mechanism Ass'y and Parts List	13
6.1. Synthesis	13
6.2. Front Panel Ass'y (A01)	13
6.3. Synthesis Mechanism Ass'y (A02)	15
6.4. Front Chassis Ass'y (B01)	16
6.5. Cover Plate Ass'y (B02)	16
6.6. Mechanism Ass'y (B03)	17
6.7. Rear Panel Ass'y (B04)	19
7. Mounting Diagrams and Parts List of ICs and Semiconductors	19
7.1. Power Switch P.C.B. Ass'y	19
7.2. Shut-off P.C.B. Ass'y	19
7.3. Tape LED P.C.B. Ass'y	19
7.4. MPX Filter P.C.B. Ass'y	19
7.5. Headphone Volume P.C.B. Ass'y	19
7.6. Volume P.C.B. Ass'y	20
7.7. Input Bal. Amp. A P.C.B. Ass'y	20
7.8. Input Bal. Amp. B P.C.B. Ass'y	20
7.9. Unbal. Input P.C.B. Ass'y	20
7.10. Unbal. Output P.C.B. Ass'y	20
7.11. Output Bal. Amp. P.C.B. Ass'y	20
7.12. Ext. NR P.C.B. Ass'y	21
7.13. Meter Amp. P.C.B. Ass'y	21
7.14. Dolby NR Switch P.C.B. Ass'y	21
7.15. Control Switch P.C.B. Ass'y	22
7.16. Counter P.C.B. Ass'y	22
7.17. Tape Switch P.C.B. Ass'y	23
7.18. Fuse P.C.B. Ass'y	23
7.19. Main P.C.B. Ass'y	24
8. Schematic Diagram	26
8.1. Schematic Diagram	26
8.2. IC Block Diagrams	27
9. Timing Chart and Eq. Amp. Frequency Response	27
10. Block Diagrams	29
10.1. Amplifier Section	29
10.2. Mechanism Control Section	30

1. GENERAL

1.1. Introduction

This Service Manual is prepared for U.S.A. and Canada versions. For Australia, Others (220V fixed) and 220V Class 2 versions, refer to the separate-volume supplement. Further, parts list of mounting diagrams and wiring diagram are included in the supplement. This Service Manual applies to the Models bearing serial Nos. A12802010 and greater.

1.2. Packing Materials and Owner's Manual

<u>Part No.</u>	<u>Description</u>	<u>Q'ty</u>
0F03847A	Carton Box	1
0F03859A	Packing	2
0F03670A	Polyethylene Sheet	1
0D04506A	Owner's Manual	1

2. TEST TAPES AND GAUGES

- (1) 400 Hz Level Tape (DA09005B)
- (2) 1 kHz Track Alignment Tape (DA09007B)
- (3) 10 kHz PB Frequency Response Tape (DA09003B)
- (4) 15 kHz PB Frequency Response Tape (DA09002B)
- (5) 20 kHz PB Frequency Response Tape (DA09001B)
- (6) 15 kHz Azimuth Tape (DA09004B)
- (7) 3 kHz Speed and Wow/Flutter Tape (DA09006C)
- (8) Tape Travelling Cassette (DA09071A)
- (9) Reference EXII Tape (DA09066B) for Normal Position
- (10) Reference SX Tape (DA09025B) for High Position
- (11) Reference ZX Tape (DA09037B) for Metal Position
- (12) EH Tilt Check Gauge S (DA09088A)
- (13) Stroke Check Gauge S (DA09090A)
- (14) Tape Guide Height Check Gauge S (DA09091A)
- (15) Tilt Check Gauge (DA09039B)

3. MECHANICAL ADJUSTMENTS

3.1. Record Head and Playback Head Tilt Adjustment

Remove the Cover Plate Ass'y by loosening two screws. Refer to Fig. 3.1.

- (1) Remove the pad lifter from the playback head.
- (2) Load a Tilt Check Gauge in the cassette deck.
- (3) Clip the grounding terminal of the Tilt Check Gauge with one end of the cord with clip, and the chassis of the cassette deck with the other end.
- (4) Remove both of the Height Gears.
- (5) Set the cassette deck in Play mode. Check to insure whether the Beacons Playback Head "Upper" or "Lower" and Record Head "Upper" or "Lower" are illuminating. In order not to give damages onto the head surfaces, push both of slide knobs of the Gauge to away from the heads, then return them to their original places to be in contact with record head and playback head surfaces after Play mode is securely locked.
- (6) Beacon Playback Head "Lower" will light on when height adjustment screw (PH) turned counterclockwise but Playback Head "Upper" when clockwise. Adjust so that both "Upper" and "Lower" will light on even when you move the slide knob away from the head and then return it to the original place.
- (7) Same procedures will apply to the Beacons Record Head "Upper" and "Lower", except for the height adjustment screw (RH).
- (8) Set the cassette deck in Stop mode and fit both of the serrated Height Gears. Then set the cassette deck again in Play mode and insure all of the 4 Beacons are illuminating. If not, (4) through (7) will have to be repeated till satisfactory results are obtained.
- (9) Mount the pad lifter on the playback head.

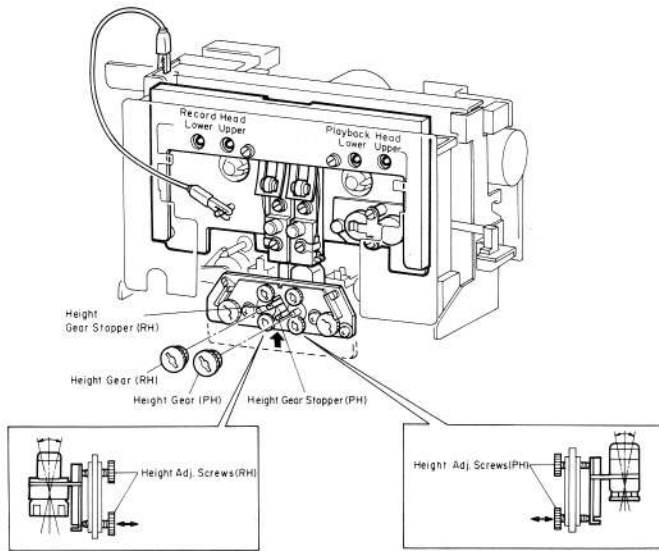

Fig. 3.1

3.2. Head Base Stroke Check

Remove the Cover Plate Ass'y. Refer to Fig. 3.2.

Note: Before you conduct this adjustment, adjust with a "Tilt Check Gauge" to insure freedom from tilt on the playback head and record head.

- (1) Load a Stroke Check Gauge S in the cassette deck.
- (2) Move Record Head Indicator and Playback Head Indicator to the direction of arrow mark "A" with your finger tip and then set the cassette deck in Play mode.

Then slowly release the Indicators and insure whether each of the Indicators is in contact with record and playback heads.

- (3) Check to insure whether the line "P" on the Playback Head Indicator meets the central line on the Indicator Plate.
- (4) Check to insure whether the line "P" on the Playback Head Indicator locates between the 2 lines on the Record Head Indicator, thus check can be made on record head stroke.

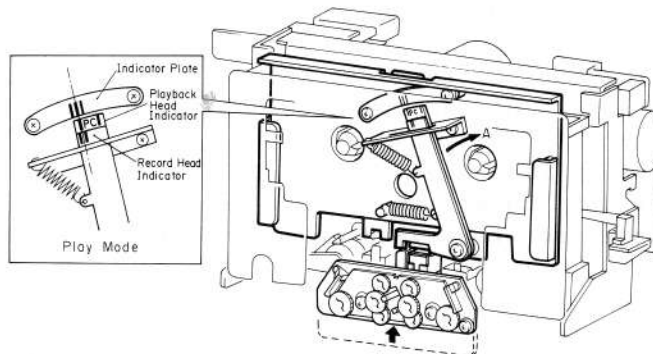

Fig. 3.2

3.3. Erase Head Stroke Adjustment and Tape Guide Height Check

Remove the Head Mount Base Ass'y and the Cover Plate Ass'y. Refer to Fig. 3.3.

(1) Erase Head Stroke Adjustment

- (a) Load a Tape Guide Height Check Gauge S in the cassette deck.
- (b) Set the cassette deck in Play mode, thus check can be made on erase head stroke through the EH Stroke Indicator.
- (c) Check to insure whether the erase head surface is aligned with red line on the EH Stroke Indicator. If not, adjust the erase head stroke by loosening screw A that assembles erase head with erase head plate.
- (d) After completion of adjustment, screw A shall be locked with lock tight paint.

(2) Supply Tape Guide Height Check

- (a) Load a Tape Guide Height Check Gauge S in the cassette deck.
- (b) Set the cassette deck in Play mode.
- (c) Slide the Supply Tape Guide Check Bar down against the supply tape guide, and check to insure that the Supply Tape Guide Check Bar is accepted by the supply tape guide.

(3) Take-up Tape Guide Height Check

- (a) Load a Tape Guide Height Check Gauge S in the cassette deck.
- (b) Set the cassette deck in Play mode.
- (c) Set the Take-up Tape Guide Check Bar down against the take-up tape guide, and check to insure that the Take-up Tape Guide Check Bar is accepted by the take-up tape guide.

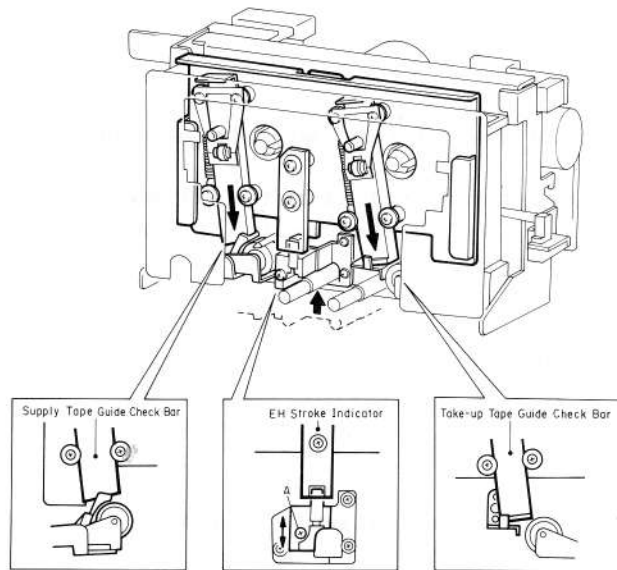

Fig. 3.3

3.4. Erase Head Height and Tilt Adjustment

Refer to Fig. 3.4.

- (1) Remove the Cassette Case Ass'y, Head Mount Base Ass'y and Cover Plate Ass'y.
- (2) Load an EH Tilt Check Gauge S in the cassette deck.
- (3) Set the cassette deck in Stop mode.
- (4) Check to insure whether one of the 3 Beacons is illuminating. Look down the mirror and slowly turn the Screw "Height" counterclockwise (or clockwise) so that the two horizontal lines on the mirror will become superposed on the line (in different color) of the erase head, and check to insure whether the first Beacon is illuminating.
- (5) Turn Screw "Tilt" counterclockwise (or clockwise) to light on the second Beacon. Excessive turning will cause the first Beacon to light off.

Adjustment of Screw "Tilt" will therefore be conducted till both of the first and the second Beacons illuminate.

- (6) Turn Screw "Azimuth" counterclockwise (or clockwise) to light on the third Beacon. Excessive turning will cause either the first or the second Beacon to light off, and therefore adjust Screw "Azimuth" until all of the 3 Beacons illuminate.
- (7) Check to insure whether the horizontal line on the mirror corresponds to that on the erase head. If not, (4) through (6) will have to be repeated till satisfactory results are obtained.
- (8) After completion of adjustment, 3 pcs. of screws shall be locked with lock tight paint.

Note: Before use of this gauge, check to insure freedom from dust or dirt, or overflow in the groove of the erase head surface.

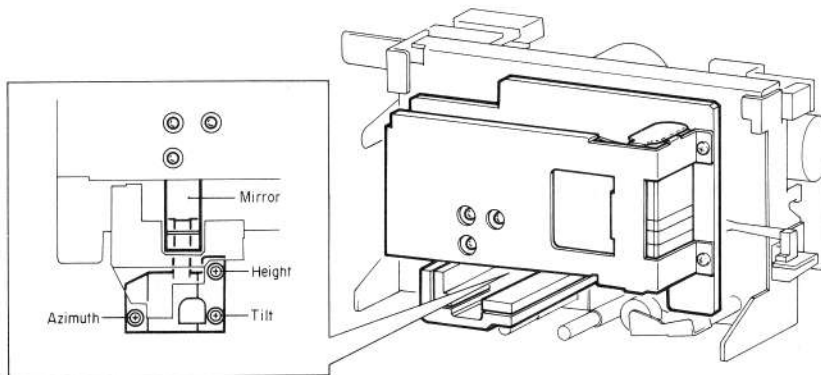

Fig. 3.4

3.5. Playback Head and Record Head Height Adjustment and Azimuth Alignment

Refer to Fig. 3.5.

(1) Playback Head Height Adjustment and Azimuth Alignment

- (a) Set the Monitor switch to Tape and connect a VTVM to the Output Jacks.
- (b) Load a 1 kHz Track Alignment B Tape and set the cassette deck in Play mode.
- (c) Turn the PH Height Gear until the outputs of both channels become minimum.
- (d) Load a 15 kHz Azimuth Tape and set the cassette deck in Play mode.
- (e) Turn the PH Azimuth Alignment Screw until the outputs of both channels become maximum.
- (f) Repeat above steps (b) through (e) one or two times to obtain optimum performance.

(2) Record Head Height Adjustment and Azimuth Alignment

- (a) Set the cassette deck in Stop mode.
- (b) Set the Monitor switch to Tape, Eq. switch to 70 μ s and Tape Selector switch to Metal.
- (c) Load a reference ZX tape and connect a VTVM to Output Jacks (Unbalanced).
- (d) Feed in 400 Hz (-10 dBV) to the Input Jacks.
- (e) Set the cassette deck in Record and Play mode and turn the RH Height Gear until the outputs of both channels become maximum.
- (f) Feed in 15 kHz (-30 dBV) to the Input Jacks and turn the RH Azimuth Alignment Screw until the outputs of both channels become maximum.
- (g) Repeat (d) through (f) one or two times to obtain optimum performance.

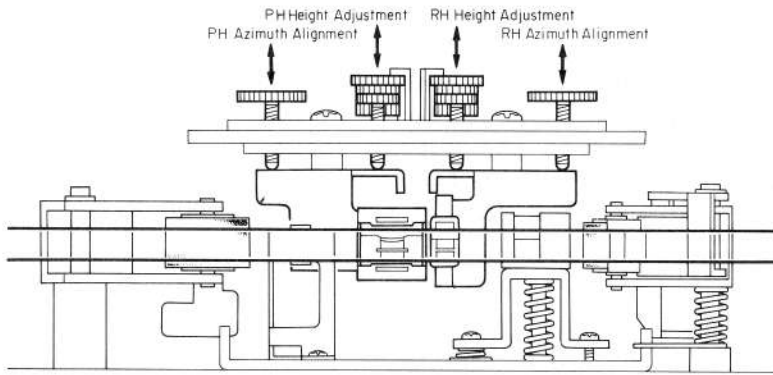

Fig. 3.5

3.6. Pressure Adjustment of Take-up Pressure Roller

Refer to Fig. 3.6.

- (1) Set the cassette deck in Play mode.
- (2) Measure the torque of the Take-up Pressure Roller and check whether the torque is in a range of 320 ± 50 g-cm.
- (3) If torque is out of the range, correct it by changing the installation point of the Pressure Roller Spring.

3.7. Tape Travelling Check

Load and playback a Tape Travelling Cassette and check the following:

Refer to Fig. 3.7.

- (1) Tape is in contact with heads sufficiently.
- (2) Tape waviness is small on the heads and pressure rollers.
- (3) Tape is free from waviness or slippage from the tape guides.

3.8. Eject Damper Adjustment

Refer to Fig. 3.8. Load a cassette tape and, with opening the Cassette Case by pressing the Eject button and closing it by hand, adjust the speed of damper action by the Damper Adjustment Screw.

3.9. Reel Motor Speed Adjustment in Play Mode

- (1) To warm-up the cassette deck, load a C-60 cassette tape and play it back.
- (2) After more than four minutes, load a torque meter TW-211 (made by Sony) and set the cassette deck in Play mode.
- (3) Adjust VR601 on the Main P.C.B. Ass'y to obtain exactly 50 g-cm on the torque meter.

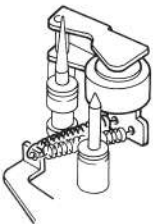

Fig. 3.6



Fig. 3.7

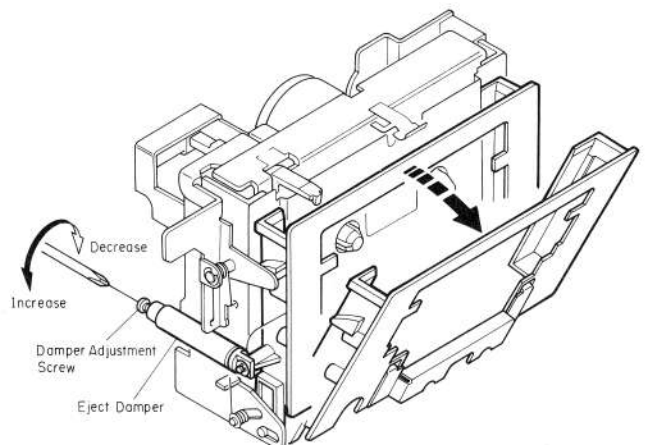

Fig. 3.8

3.10. Tape Speed Adjustment

Refer to Fig. 3.9.

- (1) Set the Pitch Control Knob on the Front Panel to its mechanical center position.
- (2) Connect a frequency counter to the Output Jacks.
- (3) Load a 3 kHz Speed and Wow/Flutter Tape and play it back.
- (4) Adjust VR101 on the Motor P.C.B. Ass'y to obtain 3,000 Hz on the frequency counter.
CCW: Motor runs fast.
CW: Motor runs slowly.

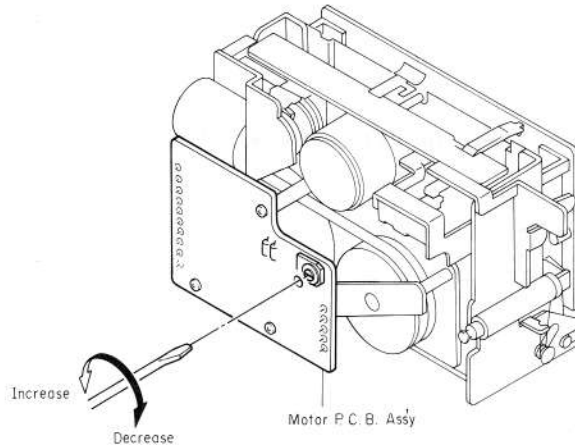

Fig. 3.9

3.11. Lubrication

The tape transport mechanism is of a lubrication-free type. However, when the following parts are replaced, apply the specified lubricant.

- (1) Molykote [®] Grease (X5-6020)
Cam Motor Pulley
Thrust portion on the Capstan Shaft
- (2) FLOIL GB-TS-1
Washer between Reel Hub Ass'y and Back Tension Spring
- (3) Diamond Oil (EP56)
Reel Hub Shaft
- (4) Anderol 456
Capstan Shaft

Note: We suggest that you use the above specified lubricant or equivalent type. The company dealing in the above lubricant is as follows:

- (a) Molykote [®] Grease (X5-6020)
Dowcorning Co., Ltd., 1-15-1 Nishishinbashi, Minato-ku, Tokyo, Japan
- (b) FLOIL GB-TS-1
Kanto Chemicals Co., Ltd., 2-7 Kanda Sakuma-cho, Chiyoda-ku, Tokyo, Japan
- (c) Diamond Oil (EP-56)
Mitsubishi Oil Co., Ltd., 1-2-4 Toranomom, Minato-ku, Tokyo, Japan
- (d) Anderol 456
Toyo Kokusai Oil Co., Ltd., 3-3-5 Hatchobori, Chuo-ku, Tokyo, Japan

4. PARTS LOCATION FOR ELECTRICAL ADJUSTMENT

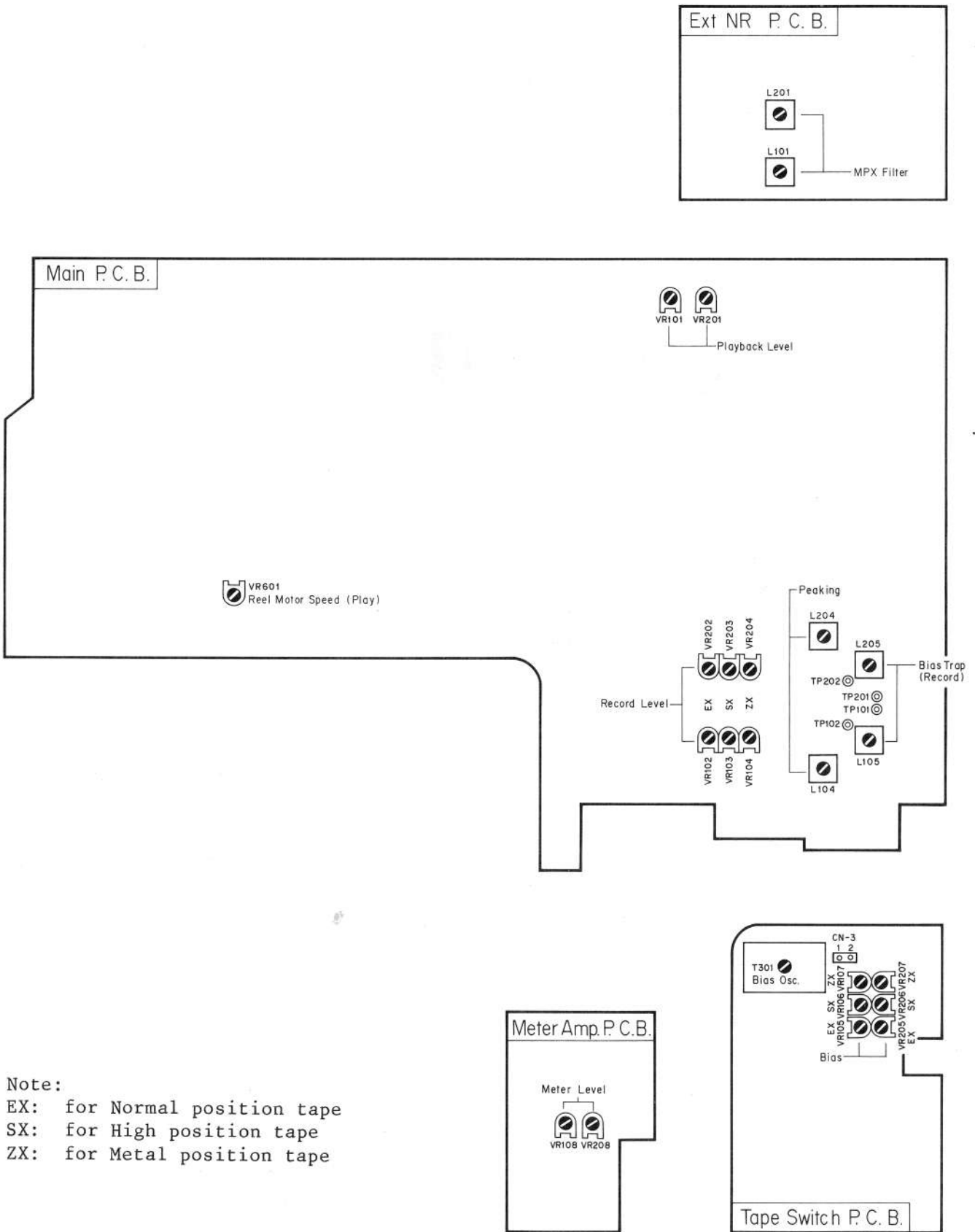

Note:

- EX: for Normal position tape
- SX: for High position tape
- ZX: for Metal position tape

Fig. 4

5. ELECTRICAL ADJUSTMENTS

5.1. Adjustment Instructions

- Notes: 1. Electrical adjustment should be performed after mechanical adjustment is completed.
2. Before adjustment, set the Pitch Control on the Front Panel to its mechanical center position.
3. Adjustment can be made by way of either the XLR Line Input/Output Jacks (Balanced) or the 1/4-Inch Line Input/Output Jacks (Unbalanced). However, when the former Jacks are used, a balanced type transformer must be connected between the Jacks and measurement instruments to be used as shown in Fig. 5.1.

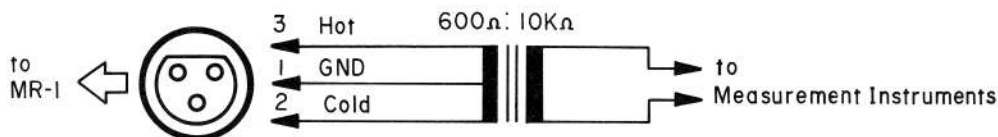

Fig. 5.1

STEP	ITEM	SIGNAL SOURCE	OUTPUT CONNECTION	MODE	ADJUSTMENT	REMARKS
1	Tape Speed Adjustment	3 kHz Speed and Wow/Flutter Tape	Frequency Counter to Output Jacks	Playback Eq. - 70 μ s	Motor P.C.B. VR101	1. Set the Pitch Control to its mechanical center position. 2. Adjust VR101 to obtain 3 kHz $\pm 0.5\%$ on the frequency counter.
2	Meter Level Calibration	400 Hz to Input Jacks	VTVM to Output Jacks (Unbalanced)	Monitor - Source	Meter Amp. P.C.B. VR108 VR208	1. Set the Output Level control to max. 2. Feed in 400 Hz and adjust the Input Level controls to obtain -12 dBV on the VTVM. 3. Adjust VR108 (VR208) so that the 0 dB segment of the level meter starts illuminating. 4. Adjust the Input Level controls to obtain -8 dBV on the VTVM and check to insure that the upper segment of the 0 dB segment starts illuminating.
3	MPX Filter Adjustment	19 kHz ± 100 Hz to Input Jacks	VTVM to Output Jacks (Unbalanced)	Monitor - Source NR Selector - Ext. MPX - ON	Ext. NR P.C.B. L101 L201	1. Set the Output Level control to max. 2. Adjust the Input Level controls to obtain -10 dBV (316 mV) on the VTVM. 3. Set the MPX Filter switch to ON and adjust L101 (L201) to obtain minimum reading on the VTVM (the minimum reading will be less than -40 dBV (10 mV).
4	Playback Head Track Alignment	1 kHz Track Alignment B Tape	VTVM to Output Jacks	Playback Monitor - Tape NR Selector - Ext. MPX - OFF	PH Height Gear	Adjust the PH Height Gear to obtain minimum readings for both channels on the VTVM. Refer to "Playback Head Height Adjustment and Azimuth Alignment" in item 3.5.

STEP	ITEM	SIGNAL SOURCE	OUTPUT CONNECTION	MODE	ADJUSTMENT	REMARKS
5	Playback Head Azimuth Alignment	15 kHz Azimuth Tape	VTVM to Output Jacks	Playback Monitor - Tape NR Selector - Ext. MPX - OFF	Playback Head Azimuth Alignment Screw	Adjust the Playback Head Azimuth Alignment Screw to obtain maximum readings for both channels on the VTVM. Refer to item 3.5. Note: Repeat steps 4 and 5 one or two times to obtain optimum performance.
6	Playback Level Calibration	400 Hz Level Tape	VTVM to Output Jacks of "To Encoder"	Same as above	Main P.C.B. VR101 VR201	Adjust VR101 (VR201) to obtain 350 mV on the VTVM.
7	Playback Frequency Response Adjustment	400 Hz Level Tape 10 kHz PB Frequency Response Tape 15 kHz PB Frequency Response Tape 20 kHz PB Frequency Response Tape	VTVM to Output Jacks (Unbalanced)	Playback Monitor - Tape Tape Selector - High Eq. - 70 μ s NR Selector - Ext. MPX - OFF	Main P.C.B. R109 R209 R110 R210	<ol style="list-style-type: none"> 1. Load a 400 Hz level tape and play it back. Adjust the Output Level control to a certain level (-10 dB for example). 2. Load 10 kHz, 15 kHz and 20 kHz PB frequency response tapes and align the playback head azimuth to obtain maximum levels on the VTVM with each tape. Short R109 (R209) and/or R110 (R210) to obtain the following levels against the level for the 400 Hz level tape. 10 kHz: -20 dB -3 to +1 dB 15 kHz: -20 dB -5 to 0 dB 20 kHz: -20 dB -7 to -1 dB Refer to "Playback Frequency Response Adjustment in item 5.2. 3. Conduct step 5 "Playback Head Azimuth Alignment".
8	Bias Oscillation Frequency and Erase Current Adjustment		VTVM across an additional 0.1 ohm resistor and Frequency Counter to CN3-1 on Tape Switch P.C.B.	Record, Pause Monitor - Source Tape Selector - Metal Eq. - 70 μ s NR Selector - Ext. MPX - OFF	Tape Switch P.C.B. T301 R301 R302	<ol style="list-style-type: none"> 1. Connect an additional resistor in series to the Erase Head and connect a VTVM across the resistor. 2. Adjust T301 to obtain 105 kHz on the frequency counter. 3. Check the erase current by the VTVM. Erase current will be in a range of 310 mA to 400 mA (typically approx. 350 mA). If erase current is not sufficient, increase it by shorting either R301 or R302. 4. After completion of the erase current adjustment, re-check the bias oscillation frequency. 5. Remove the additional 0.1 ohm resistor.
9	Record Amplifier Equalizer Adjustment	400 Hz and 23 kHz to Input Jacks	VTVM to TP101, TP201 on Main P.C.B. and Output Jacks (Unbalanced)	Same as above	Main P.C.B. L104 L204	<ol style="list-style-type: none"> 1. Remove the bias-cut jumper on the dip side of the Tape Switch P.C.B. Ass'y. 2. Feed in 400 Hz to the Input Jacks and adjust the Input Level controls to obtain -10 dBV (316 mV) on the VTVM at the Output Jacks (Unbalanced). 3. Note the readings on the VTVM at TP101 (TP201). 4. Feed in 23 kHz and adjust the Input Level controls to obtain -26 dBV on the VTVM at the output Jacks (Unbalanced). 5. Adjust L104 (L204) to obtain the same readings as in 3 at TP101 (TP201). 6. Mount the bias-cut jumper.

STEP	ITEM	SIGNAL SOURCE	OUTPUT CONNECTION	MODE	ADJUSTMENT	REMARKS
10	Bias Trap Adjustment (Record Amp.)	Remove input signals	VTVM to TP102, TP202 on Main P.C.B.	Record, Pause Monitor - Source Tape Selector - Metal Eq. - 70 μ s NR Selector - Ext. MPX - OFF	Main P.C.B. L105 L205	Adjust L105 (L205) to obtain minimum reading on the VTVM.
11	Record Head Height Adjustment	400 Hz to Input Jacks	VTVM to Output Jacks	Record, Playback Monitor - Tape Tape Selector - Metal Eq. - 70 μ s NR Selector - Ext. MPX - OFF	RH Height Gear	Adjust the RH Height Gear to obtain maximum readings for both channels on the VTVM. Refer to "Record Head Height Adjustment and Azimuth Alignment" in item 3.5.
12	Record Head Azimuth Alignment	15 kHz to Input Jacks	VTVM to Output Jacks	Same as above	Record Head Azimuth Alignment Screw	Adjust the Record Head Azimuth Alignment Screw to obtain maximum readings for both channels on the VTVM. Refer to item 3.5. Note: Repeat steps 11 and 12 one or two times to obtain optimum performance.
13	Record Level Calibration and Recording Bias Current Adjustment	400 Hz (-10 dBV) and 15 kHz (-30 dBV) to Input Jacks	VTVM and Distortion Meter to Output Jacks (Unbalanced)	Record, Playback Monitor - Source/Tape Tape Selector - Metal High/Normal Eq. - 70 μ s (Metal/High) 120 μ s (Normal) NR Selector - Ext. MPX - OFF	Main P.C.B. (Level) Metal: VR104 VR204 High: VR103 VR203 Normal: VR102 VR202 Tape Switch P.C.B. (Bias) Metal VR107 VR207 High: VR106 VR206 Normal: VR105 VR205	Adjustment should be made in the order of Metal, High and Normal. 1. Set the Monitor switch to Source. 2. Feed in 400 Hz and adjust the Input Level Control to obtain -10 dBV (316 mV) on the VTVM. 3. Set the Monitor switch to Tape. 4. Load a reference ZX tape, reference SX tape and reference EXII tape, and set the MR-1 in Record/Play mode. 5. Adjust Record Level Cal. VR104 (VR204) for ZX tape, VR103 (VR203) for SX tape and VR102 (VR202) for EXII tape to their center positions. 6. Feed in 15 kHz (-30 dBV: 31.6 mV) and adjust Bias VR107, (VR207) for ZX tape, VR106 (VR206) for SX tape and VR105 (VR205) for EXII tape to obtain the same readings as source monitor levels on the VTVM. 7. Feed in 400 Hz (-10 dBV: 316 mV) and adjust Record Level Cal. VR104 (VR204), VR103 (VR203) and VR102 (VR202) to obtain -10 dBV (316 mV) on the VTVM. 8. Repeat above 6 and 7 two or three times to obtain optimum performance. 9. Check to insure whether the total harmonic distortion is less than 0.9% for ZX tape and 1.0% for SX and EXII tapes. 10. If above is not sufficient, repeat 2 to 9 till satisfactory results are obtained.

STEP	ITEM	SIGNAL SOURCE	OUTPUT CONNECTION	MODE	ADJUSTMENT	REMARKS
14	Overall Frequency Response Adjustment	400 Hz (-10 dBV) and 20 Hz to 20 kHz (-30 dBV) to Input Jacks	VTVM to Output Jacks (Unbalanced)	Record, Playback Monitor - Source/Tape Tape Selector - Metal/High/Normal Eq. - 70 μ s (Metal/High) 120 μ s (Normal) NR Selector - Ext. MPX - OFF	Main P.C.B. L104 L204	<ol style="list-style-type: none"> Set the Monitor switch to Source. Feed in 400 Hz and adjust the Input Level controls to obtain -10 dBV (316 mV) on the VTVM. Switch the Generator output level to -30 dBV (31.6 mV). Set the Monitor switch to Tape. Load a reference ZX tape, reference SX tape and EXII tape, and record and play them back. Feed in 20 Hz to 20 kHz (-30 dBV: 31.6 mV) and check to insure whether the output levels are within -30 dBV (31.6 mV) +3 dB. If above is not sufficient, adjust L104 (L204) to obtain approx. -30 dBV (31.6 mV) on the VTVM at 20 kHz. Conduct step 13 "Record Level Calibration and Recording Bias Current Adjustment". If above is not sufficient, precise re-adjustment of step 7 "Playback Frequency Response", replacement of Playback Head or Record Head, or check on item 3.7 "Tape Travelling Check" will be required.

5.2. Playback Frequency Response Adjustment

Figs. 5.2 and 5.3 show the playback amp. circuit for adjustment and the playback equalization curve.

This adjustment will be required if playback level is not sufficient during playing back a 20 kHz PB frequency response tape.

The peaking portion of the equalization curve compensates the gap loss of the playback head. Peaking level is varied by the shortcircuit of R109 (R209) and/or R110 (R210) on the Main P.C.B. Ass'y.

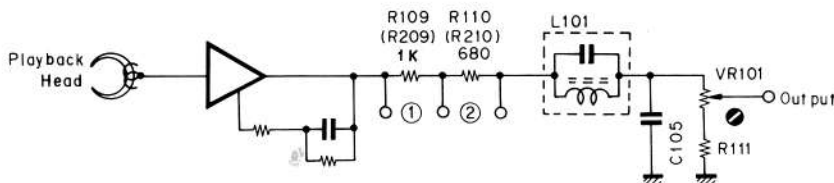

Fig. 5.2

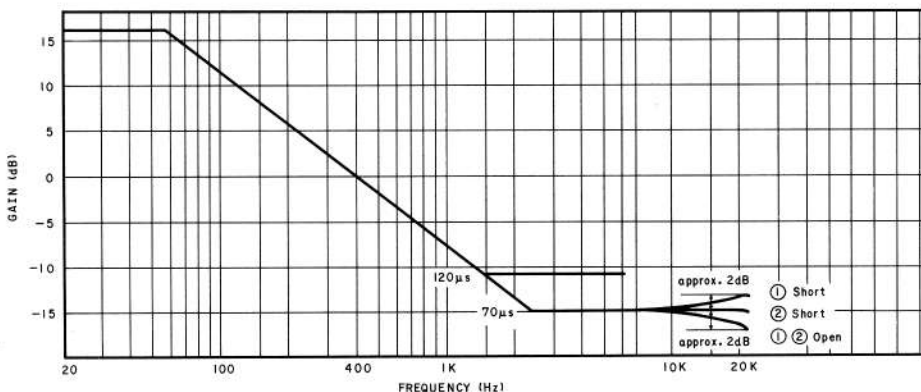

Fig. 5.3

6. MECHANISM ASS'Y AND PARTS LIST

6.1. Synthesis

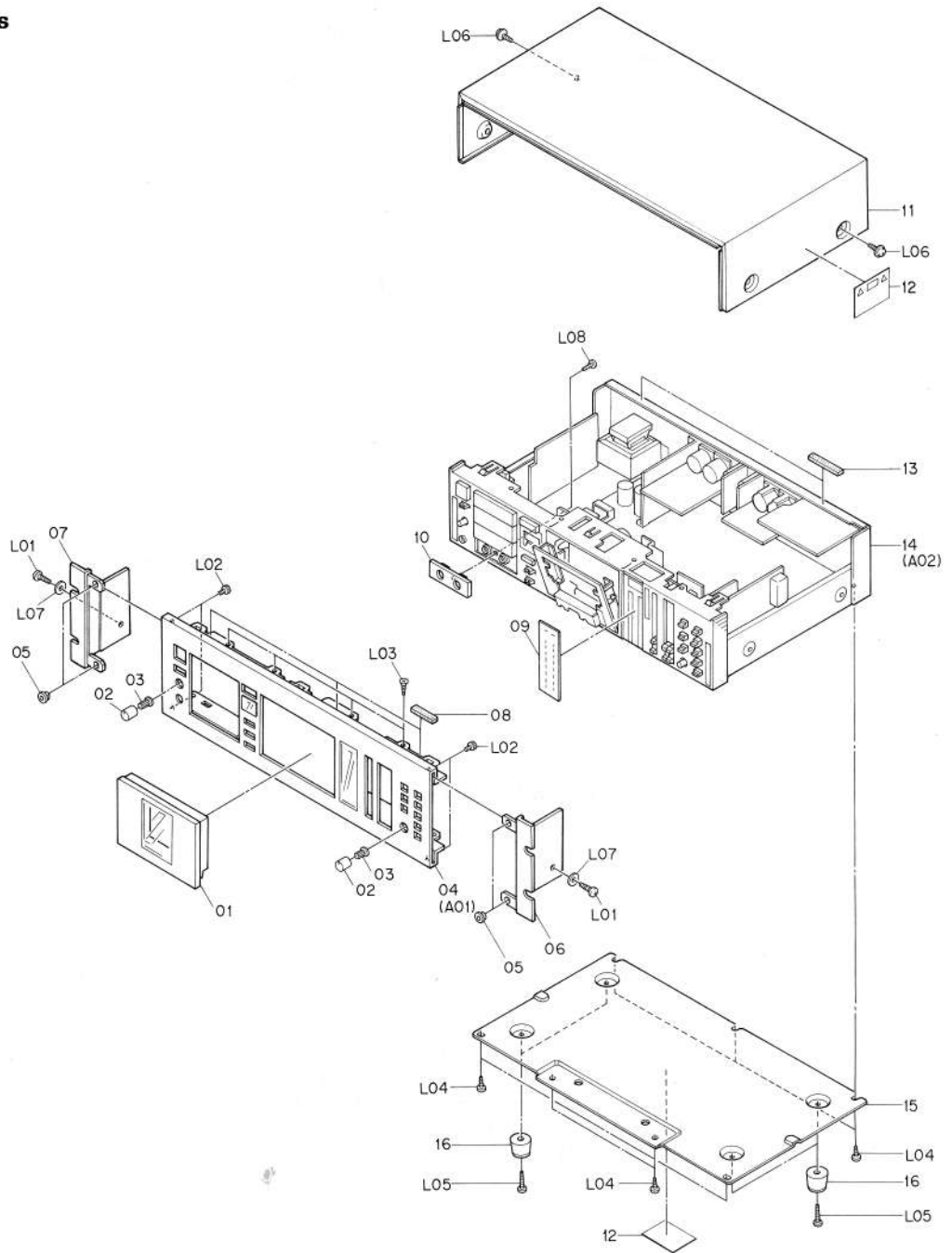

Fig. 6.1

6.2. Front Panel Ass'y (A01)

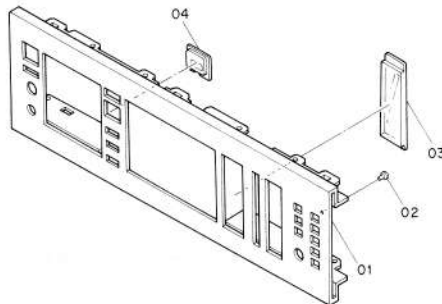

Fig. 6.2

<u>Ref. No.</u>	<u>Part No.</u>	<u>Description</u>	<u>Q'ty</u>
		Synthesis	
01	HA04787A	Lid Ass'y	1
02	OH04596A	Volume Knob	2
03	OH03737A	Volume Knob Base	2
04	HA04728A	Front Panel Ass'y	1
05	OJ04982A	Side Stopper	4
06	OH04605A	Side Panel R	1
07	OH04606A	Side Panel L	1
08	OJ04628A	Top Cover Cushion (Front)	3
09	OH04592A	Meter Scale	1
10	OH04604B	Input Jack Cover	1
11	OH04156B	Top Cover	1
12	OM04377B	Caution Label	1
13	OJ04629A	Top Cover Cushion (Back)	2
14	-	Synthesis Mechanism Ass'y	1
15	OJ04762A	Bottom Cover	1
16	OJ04980A	Leg	4
-	OJ04581A	Counter Cushion	3
-	OJ05014A	Line Mold Cushion	2
L01	OE00944A	BT4x15 Philips Binding (Black Chromate)	2
L02	OE00996A	M3x6 Hex. Socket Head (Black Chromate)	4
L03	OE03054A	BT3x8 Philips Countersunk	4
L04	OE00868A	BT3x8 Philips Binding	7
L05	OE03136A	BT3x16 Philips Binding (Black Chromate)	4
L06	OE03032A	BT4x8 Philips Pan Washer-faced (Black Chromate)	2
L07	OE00914A	Washer 4x8x0.5	2
L08	OE00854A	BT2.6x4 Philips Binding	1

<u>Ref. No.</u>	<u>Part No.</u>	<u>Description</u>	<u>Q'ty</u>
A01	HA04728A	Front Panel Ass'y	1
01	OH04523A	Front Panel	1
02	OH04240A	LED Lens	1
03	OH04251C	Meter Lens	1
04	OH04607A	Counter Cover	1

6.3. Synthesis Mechanism Ass'y (A02)

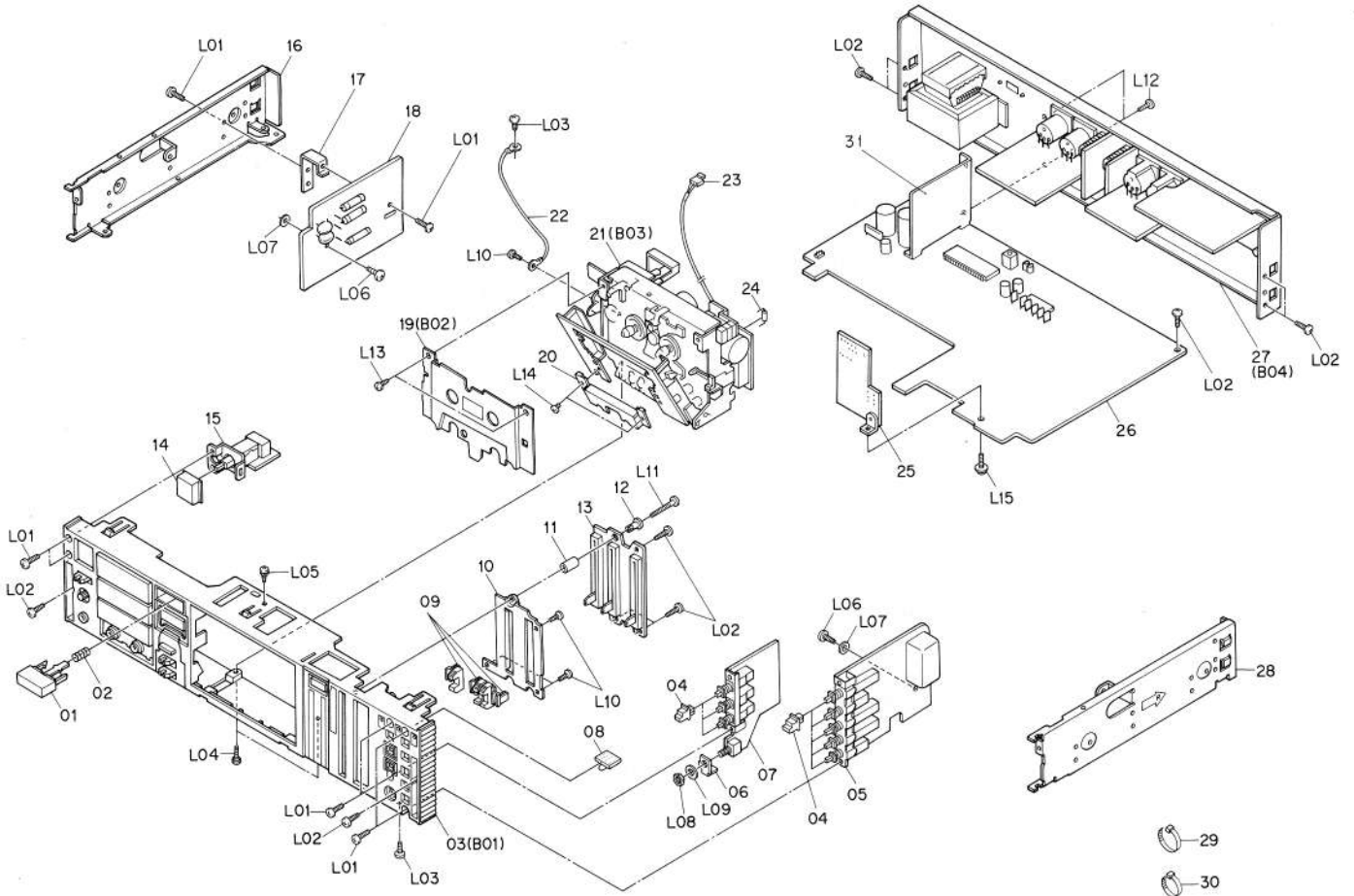

Fig. 6.3

6.4. Front Chassis Ass'y (B01)

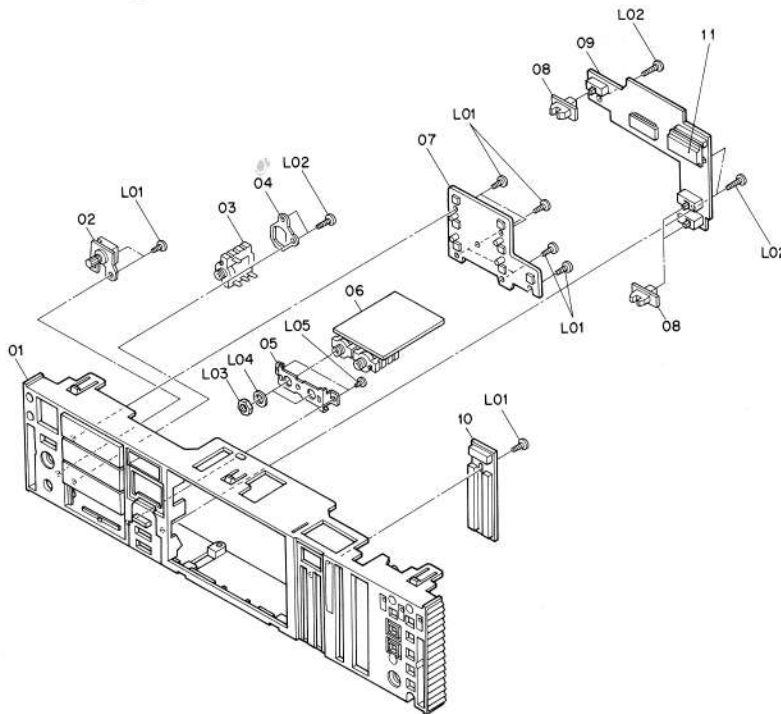

Fig. 6.4

Ref. No.	Part No.	Description	Q'ty
A02	-	Synthesis Mechanism Ass'y	1
01	HA04786A	Eject Button Ass'y	1
02	OJ04765A	Spring	1
03	HA04727A	Front Chassis Ass'y	1
04	OH04248A	Push Switch Button	8
05	BA05530A	Tape Switch P.C.B. Ass'y	1
06	OJ04838A	Volume Holder	1
07	BA05529B	Dolby NR Switch P.C.B. Ass'y	1
08	BA05649A	Tape LED P.C.B. Ass'y	1
09	OH04601A	Slide Volume Knob	3
10	OH04598A	Slide Volume Plate	1
11	OJ04703A	P.C.B. Spacer A	1
12	OJ04704A	P.C.B. Spacer B	1
13	BA05544A	Volume P.C.B. Ass'y	1
14	OH04602A	Power Switch Knob	1
15	BA05540A	Power Switch P.C.B. Ass'y	1
16	OJ04841B	Side Chassis (L)	1
17	OJ04839A	P.C.B. Holder	1
18	BA05546B	Fuse P.C.B. Ass'y	1
19	HA04793A	Cover Plate Ass'y	1
20	OH04415A	Cover Plate	1
21	CA08650A	Mechanism Ass'y	1
22	BA05400A	Earth Wire Ass'y	1
23	OB82311A	3P-H Connector	1
24	OB09685A	Carbon Resistor 2.2 k-ohm 1/6W J	1
25	BA05525A	Meter Amp. P.C.B. Ass'y	1
26	BA05517A	Main P.C.B. Ass'y	1
27	HA04722A	Rear Panel Ass'y (U.S.A.)	1
	HA04730A	Rear Panel Ass'y (Canada)	1
28	OJ04773D	Side Chassis (R)	1
29	OB08515A	Insu-Lock BK-1	8
30	OB90012A	Insu-Lock 140 mm	5
31	BA05548A	Heat Sink Ass'y (consists of the followings)	1
	(OB06452A)	(Transistor 2SD1406 (Y))	(1)
	(OB06451A)	(Transistor 2SB1015 (Y))	(1)
	(OB90067A)	(Heat Sink)	(1)
	(OE00507A)	(Nut Hex. M3)	(2)
	(OE00510A)	(M3x8 Philips Pan (2A))	(2)
-	OJ04890A	P.C.B. Holder	1
-	OJ05023A	P.C.B. Shield Plate	1
-	OB08525A	Fuse 2A	2
-	OB08374A	Fuse 1A	1
L01	OE00766A	M3x8 Philips Binding	8
L02	OE00868A	BT3x8 Philips Binding	10
L03	OE00857A	BT3x6 Philips Binding	2
L04	OE03074A	BT2.6x8 Philips Binding with Toothed-Lock Washer	2
L05	OE03212A	BT2.6x6 Philips Binding with Toothed-Lock Washer	1
L06	OE03217A	BT4x8 Philips Binding	2
L07	OE03238A	Fiber Washer 4x10x1	2
L08	-	Nut	(1)
L09	-	Washer	(1)
L10	OE00859A	BT2.6x6 Philips Binding	4
L11	OE00835A	BT3x25 Philips Pan	1

Ref. No.	Part No.	Description	Q'ty
L12	OE00921A	BT3x8 Philips Binding (Black Chromate)	2
L13	OE00824A	BT2.6x6 Philips Pan (Black Chromate)	2
L14	OE03202A	M2.6x3 Philips Binding (Black Chromate)	2
L15	OE00607A	M3x8 Philips Binding (3A)	1
B01	HA04727A	Front Chassis	1
01	HA04720A	Front Chassis Sub Ass'y	1
02	BA05547A	Headphone Volume P.C.B. Ass'y	1
03	OB08511A	Headphone Jack	1
04	OJ04611A	Headphone Plate	1
05	OJ04983B	Input Jack Holder	1
06	BA05646A	Input Bal. Amp. B P.C.B. Ass'y	1
07	BA05542A	Control Switch P.C.B. Ass'y	1
08	OH04603A	Slide Switch Knob	3
09	BA05543A	Counter P.C.B. Ass'y	1
10	BA05545A	Level Indicator Ass'y	1
11	OB12098A	Counter LED	1
-	OJ05106A	Counter Himelon	1
L01	OE00857A	BT3x6 Philips Binding	9
L02	OE00868A	BT3x8 Philips Binding	5
L03	-	Nut	(1)
L04	-	Washer	(1)
L05	OE00869A	BT2.6x4 Philips Binding	2

6.5. Cover Plate Ass'y (B02)

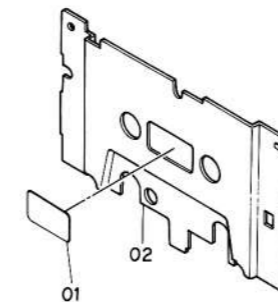

Fig. 6.5

Ref. No.	Part No.	Description	Q'ty
B02	HA04793A	Cover Plate Ass'y	1
01	OM04196A	Cassette Label (Silver)	1
02	OH04437B	Cover Plate	1

6.6. Mechanism Ass'y (B03)

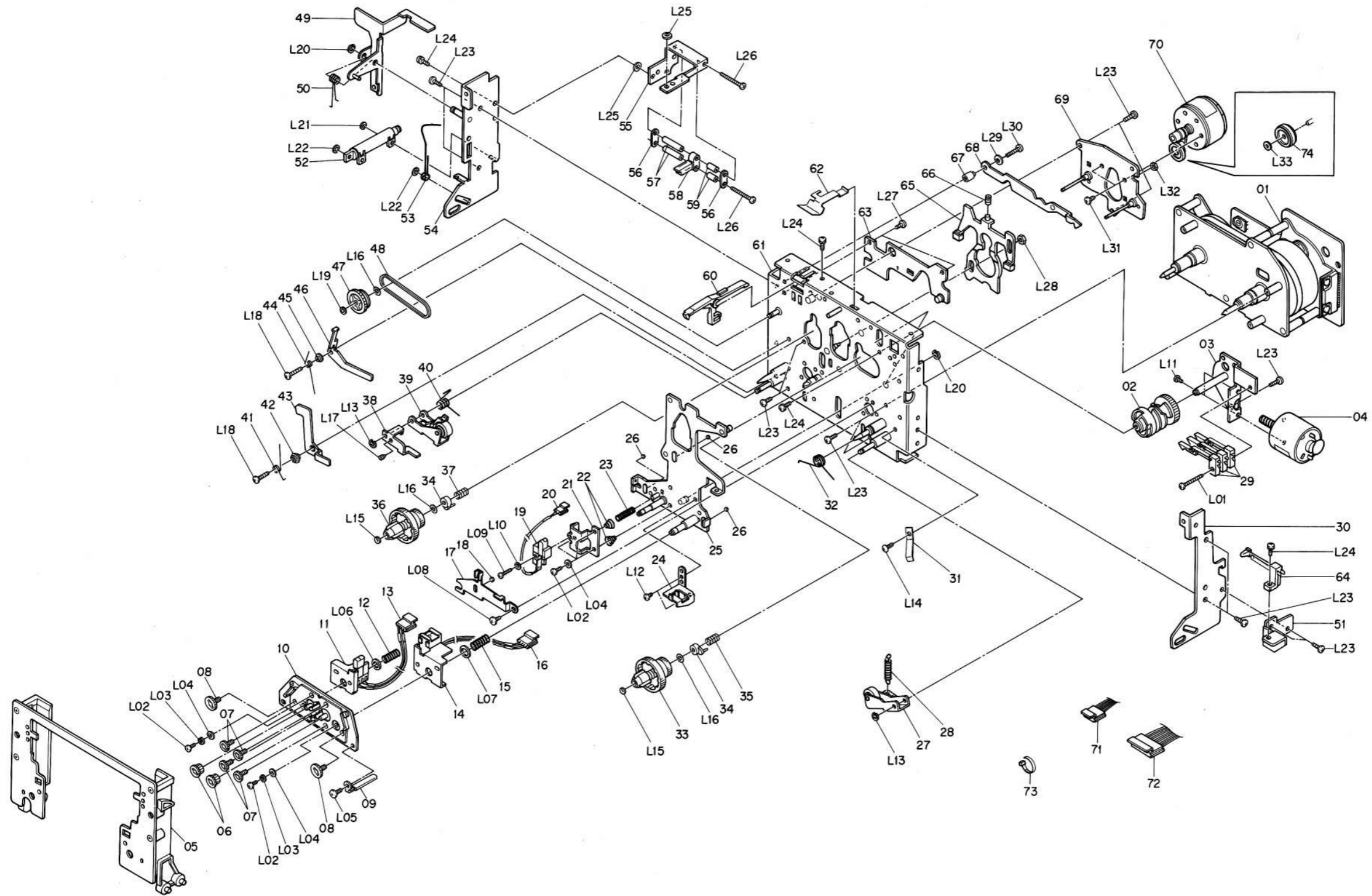

Fig. 6.6

Ref. No.	Part No.	Description	Q'ty
B03	CA08650A	Mechanism Ass'y	1
01	CA80206A	D.D. Motor Ass'y	1
02	OC80026A	Cam	1
03	OC80028A	Control Motor Holder	1
04	CA80007A	Control Motor Ass'y	1
05	CA80200A	Cassette Case Ass'y	1
06	OC08762A	Head Height Adjustment Gear	2
07	OC08761A	Head Height Adjustment Screw	4
08	OC08763A	Azimuth Alignment Screw	2
09	OC80605A	Wire Clamper	1
10	CA08637A	Head Mount Base Sub Ass'y	1
11	CA08659B	R-3L Record Head Ass'y	1
12	OC08776A	Head Plate Spring (L)	1
13	OC80606A	4P-H Connector	1
14	CA08658B	P2H-3L Playback Head Ass'y	1
15	OC08775A	Head Plate Spring (R)	1
16	OC80607A	4P-H Connector	1
17	OC80003A	Head Base Hold Plate	1
18	OC80004A	Steel Ball 3mm	1
19	GA02201A	E-4F Erase Head	1
20	OC80608A	2P-H Connector	1
21	OC08768A	Erase Head Hold Plate	1
22	OC08889A	Erase Head Hold Plate Tapering Spring	2
23	OC08886A	Erase Head Hold Plate Spring	1
24	OC08771A	Tape Guide Plate	1
25	CA08638A	Head Base Sub Ass'y	1
26	OC80007A	Steel Ball 2mm	3
27	CA80005A	Take-up Pressure Roller Arm Ass'y	1
28	OC80609A	Take-up Pressure Roller Arm Spring	1
29	OC80027A	Mode Switch	1
30	OC80010C	Cassette Case Holder R	1
31	OC80610A	Cassette Case Spring	1
32	OC80611A	Head Base Spring	1
33	CA80201A	Take-up Reel Hub Ass'y	1
34	OC80612A	Spring Holder	2
35	OC80613A	Take-up Reel Hub Spring	1
36	CA80202A	Supply Reel Hub Ass'y	1
37	OC80614A	Supply Reel Hub Spring	1
38	OC80615A	Pressure Roller Plate	1
39	CA80203A	Supply Pressure Roller Arm Ass'y	1
40	OC80616A	Supply Pressure Roller Arm Spring	1
41	OC80013A	Lock Lever Spring	1
42	OC80014A	Lock Lever Collar	1
43	OC80015A	Lock Lever	1
44	OC80617A	Back Tension Arm Spring	1
45	OC80618A	Back Tension Arm Collar	1
46	OC80619A	Back Tension Arm	1
47	OC80620A	Back Tension Pulley	1
48	OC80621A	Back Tension Belt	1
49	OC80021A	Eject Lever	1
50	OC80020A	Eject Lever Spring	1
51	OC80011A	Eject Sensor Holder	1
52	CA80006A	Pneumatic Damper Ass'y	1
53	OC80019A	Eject Spring	1
54	OC80018A	Cassette Case Holder L	1

Ref. No.	Part No.	Description	Q'ty
55	OC80622A	Switch Hold Plate	1
56	OC80623A	Switch Plate	2
57	OC80624A	Switch Collar A	2
58	OC80626A	Leaf Switch	1
59	OC80625A	Switch Collar B	2
60	OC80017A	Record Protect Lever	1
61	OC80627A	Mechanism Chassis	1
62	OC80022A	Cassette Hold Spring	1
63	CA80011A	Shut-off P.C.B. Ass'y	1
64	OC80012A	Eject Sensor	1
65	CA80204A	Brake Ass'y	1
66	OC80628A	Brake Spring B	1
67	OC80630A	Brake Arm Collar	1
68	OC80629A	Brake Arm	1
69	OC80030A	Reel Motor Holder	1
70	CA80205A	Reel Motor Ass'y	1
71	OC80631A	5P-H Connector	1
72	OC80632A	9P-H Connector	1
73	OC80037A	Insu-Lock	3
74	OC80635B	Ider Pulley	1
-	OC80634A	Capstan Belt	1
L01	OE03044A	FT2.5x20 Philips Pan	1
L02	OE00976A	M2x5 Philips Binding	5
L03	OE00025A	Spring Washer 2mm	2
L04	OE00117A	Washer 2x4.3x0.4	5
L05	OE00866A	M2.6x4 Philips Binding	1
L06	OC08774A	Plate Washer L	1
L07	OC08773A	Plate Washer R	1
L08	OE03228A	FT3x4 Philips Pan	1
L09	OE03232A	M1.7x7 Philips Pan	1
L10	OE03222A	Washer 1.8x3.8x0.3	1
L11	OE03234A	M2x3 Philips Pan (Chromate)	2
L12	OE00691A	M2x3 Philips Pan (Nickel)	2
L13	OE00222A	E-Ring 2mm	2
L14	OE03035A	M2x3.2 Philips Truss	1
L15	OE03049A	Washer 1.8x3.2x0.5	2
L16	OE03226A	Washer 2.1x4.5x0.1	3
L17	OE00224A	M2x3 Cup Point	1
L18	OE03043A	FT2.5x10 Philips Pan	2
L19	OE03225A	Washer 1.8x3.8x0.5	1
L20	OE00181A	E-Ring 3mm	1
L21	OE03235A	Mylar Washer 2x5x0.25	1
L22	OE03052A	CS Stopper Ring 2.4mm	2
L23	OE03229A	FT2.5x6 Philips Pan	13
L24	OE03236A	M2x5 Philips Pan (2A)	4
L25	OE03227A	Washer 2.7x5.0.5	2
L26	OE03231A	M2x30 Philips Pan	2
L27	OE03041A	FT2.5x4 Philips Pan	2
L28	OE03237A	Nut Hex. M2.6	1
L29	OE03233A	Washer 2.6x8xl	1
L30	OE03230A	ST2.6x12 Philips Pan	1
L31	OE03045A	M2.6x3 Philips Binding	2
L32	OE00694A	Nut Hex. M2	1
L33	OE03245A	Mylar Washer 1.3x3.3x0.3	1

7. MOUNTING DIAGRAMS AND PARTS LIST FOR ICS AND SEMICONDUCTORS

6.7. Rear Panel Ass'y (B04)

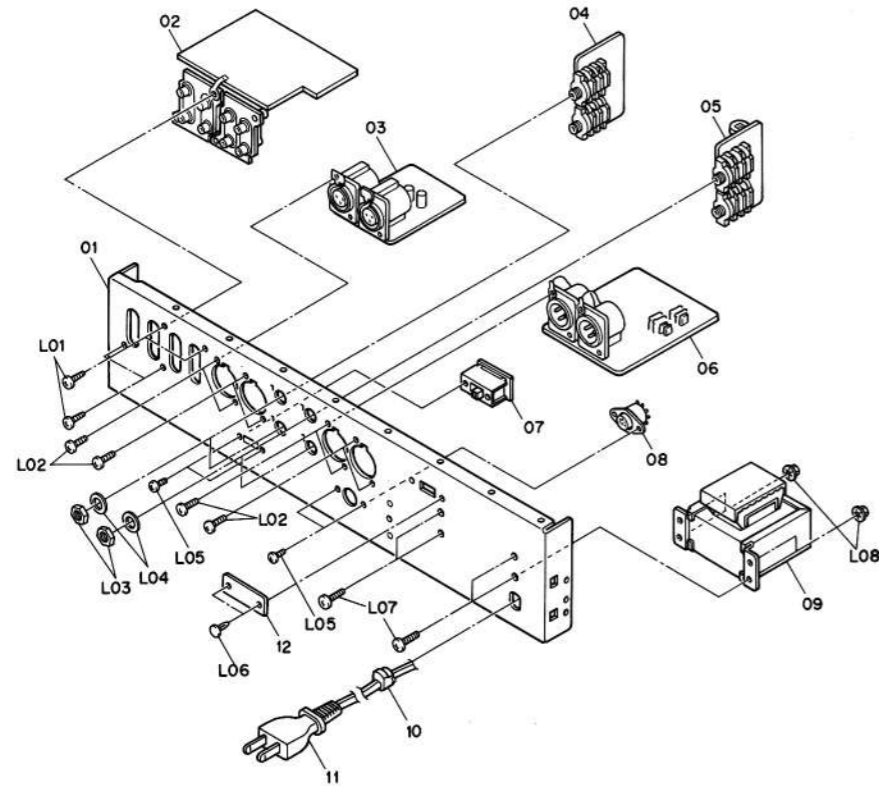

Fig. 6.7

Ref. No.	Part No.	Description	Q'ty
B04	HA04722A	Rear Panel Ass'y (U.S.A.)	1
	HA04730A	Rear Panel Ass'y (Canada)	1
01	OH04520B	Rear Panel	1
02	BA05645A	Ext. NR P.C.B. Ass'y	1
03	BA05644A	Input Bal. Amp. A P.C.B. Ass'y	1
04	BA05647A	Unbal. Input P.C.B. Ass'y	1
05	BA05648A	Unbal. Output P.C.B. Ass'y	1
06	BA05643A	Output Bal. Amp. P.C.B. Ass'y	1
07	BA05650A	MPX Filter Switch P.C.B. Ass'y	1
08	BA05734A	8P DIN Socket Ass'y (consisting of the followings)	1
	(OB08584A)	(8P DIN Socket)	(1)
	(OB82402A)	(SCN-S Connector 8P 150mm)	(1)
09	OB50037B	Power Transformer 120V	1
10	OB08037U	Cord Bushing C 4P-4 (U.S.A.)	1
	OB08351A	Cord Bushing 4K-4 (Canada)	1
11	OB08533A	Power Cord (U.S.A.)	1
	OB08504A	Power Cord (Canada)	1
12	OJ04601B	Switch Cover	1
L01	OE00921A	BT3x8 Philips Binding (Black Chromate)	4
L02	OE00818A	M3x8 Philips Binding (Black Chromate)	8
L03	-	Nut	2
L04	-	Washer	2
L05	OE00824A	M2.6x6 Philips Pan (Black Chromate)	4
L06	OB08583A	Plastic Rivet	2
L07	OE03058A	M4x8 Philips Binding (Black Chromate)	2
L08	OE00928A	Nut Hex. M4 Washer-faced	4

- Note: 1. Mounting diagram shows a dip side view of the printed circuit board.
 2. Diode is 1SS176, 1SS53, or 1S1555 unless otherwise specified.
 3. Following transistors are interchangeable with each other.
 a. 2SA733, 2SA608SP, 2SA1048, 2SA1175
 b. 2SC945, 2SC536SP, 2SC2458, 2SC2785
 4. Abbreviation for part name:
 TR - Transistor, SiD - Silicon Diode, ZD - Zener Diode

7.1. Power Switch P.C.B. Ass'y

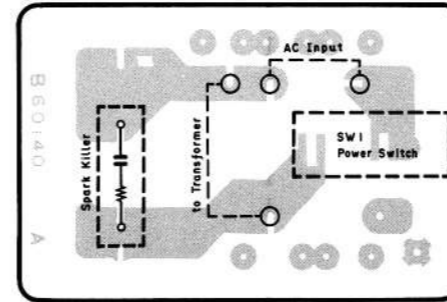

Fig. 7.1

7.2. Shut-off P.C.B. Ass'y

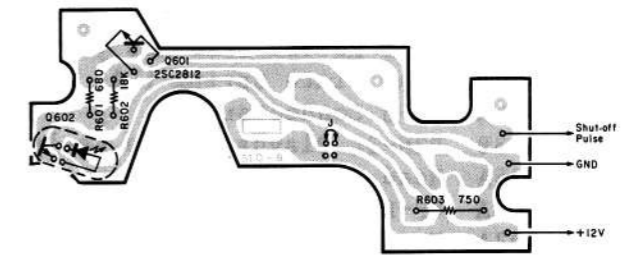

Fig. 7.2

7.3. Tape LED P.C.B. Ass'y

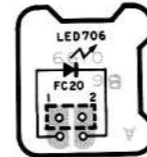

Fig. 7.3

7.6. Volume P.C.B. Ass'y

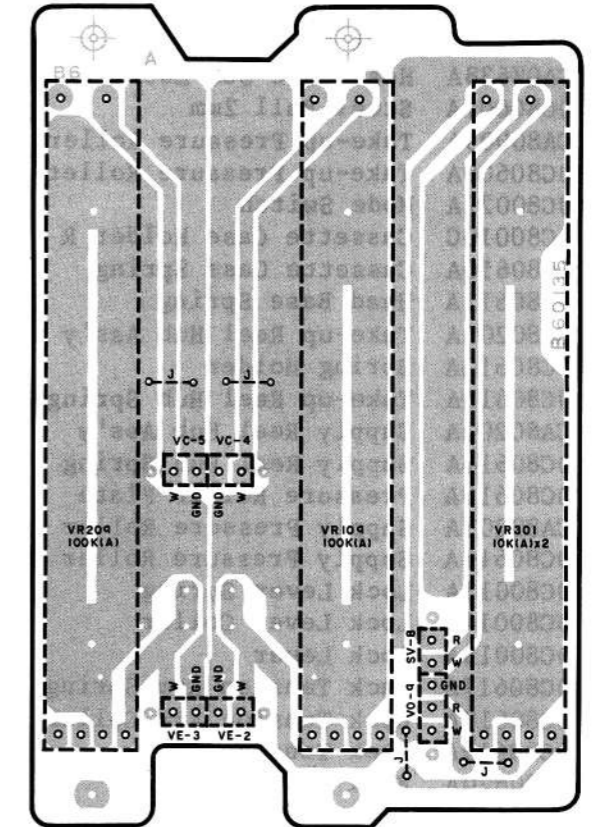

Fig. 7.6

7.4. MPX Filter P.C.B. Ass'y

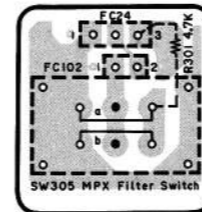

Fig. 7.4

7.5. Headphone Volume P.C.B. Ass'y

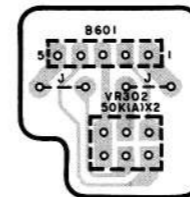

Fig. 7.5

7.7. Input Bal. Amp. A P.C.B. Ass'y

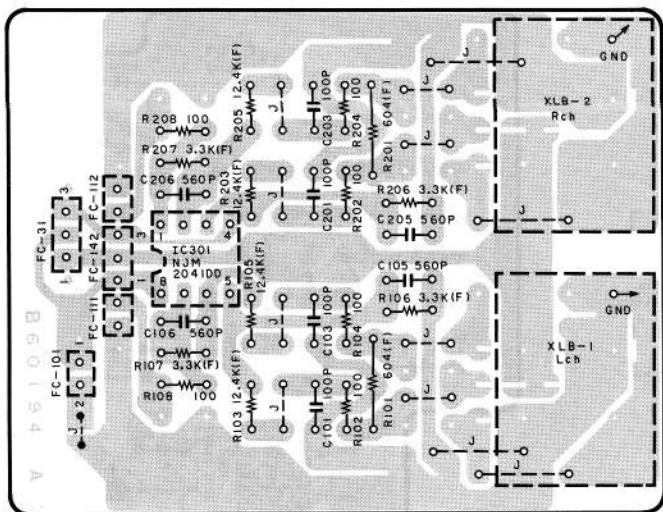

Fig. 7.7

7.8. Input Bal. Amp. B P.C.B. Ass'y

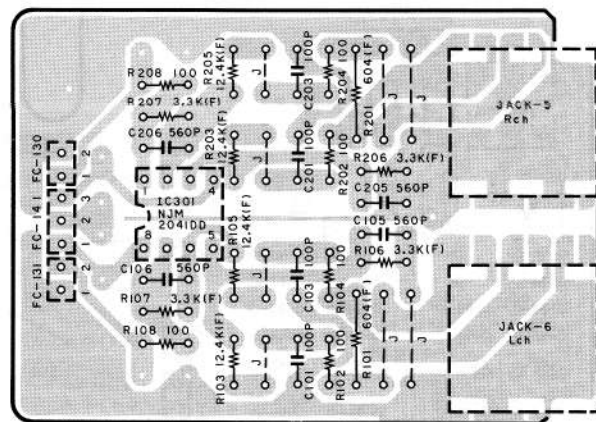

Fig. 7.8

7.9. Unbal. Input P.C.B. Ass'y

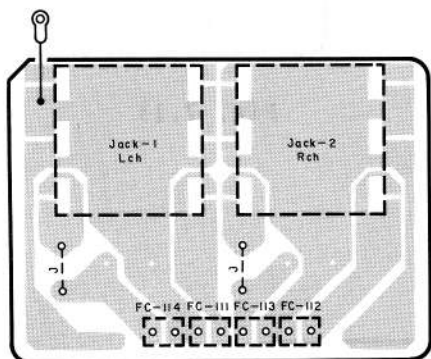

Fig. 7.9

7.10. Unbal. Output P.C.B. Ass'y

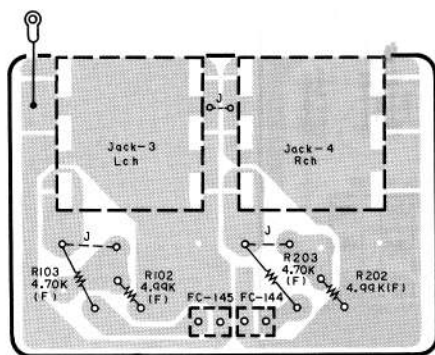

Fig. 7.10

7.11. Output Bal. Amp. P.C.B. Ass'y

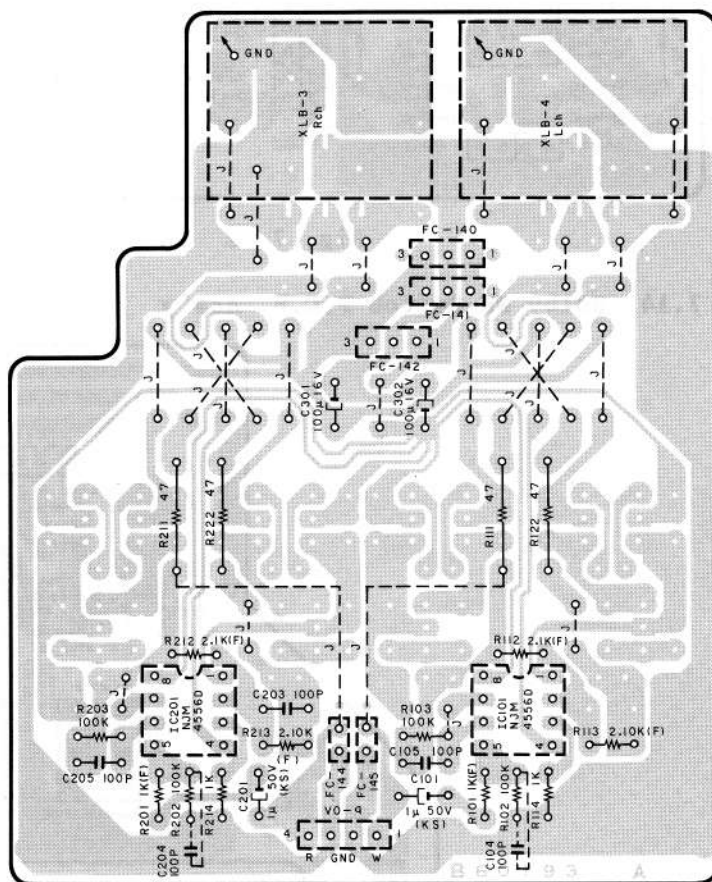

Fig. 7.11

7.12. Ext. NR P.C.B. Ass'y

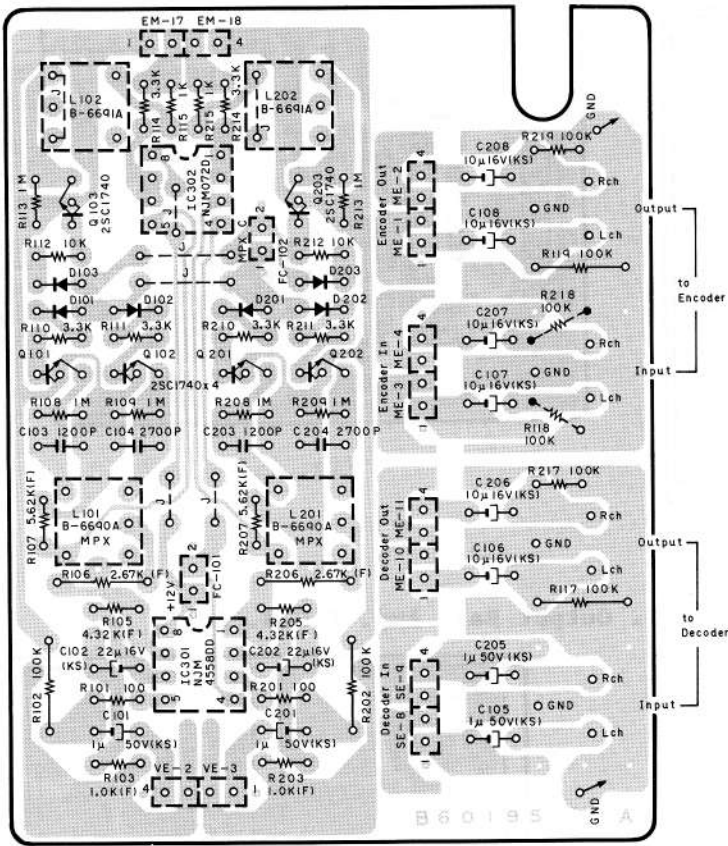

Fig. 7.12

7.13. Meter Amp. P.C.B. Ass'y

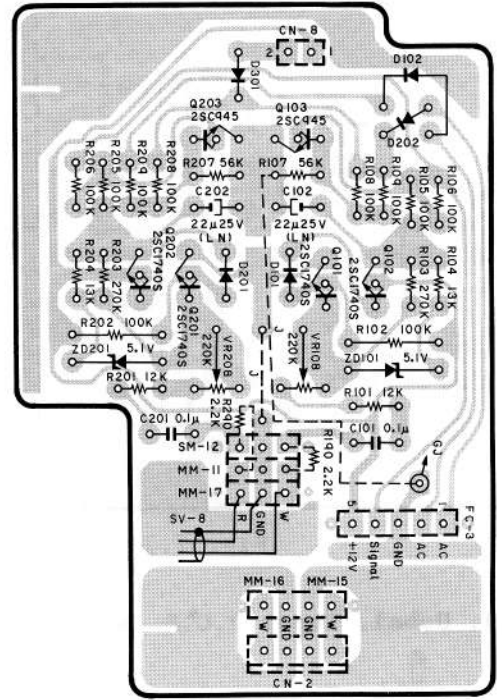

Fig. 7.13

7.14. Dolby NR Switch P.C.B. Ass'y

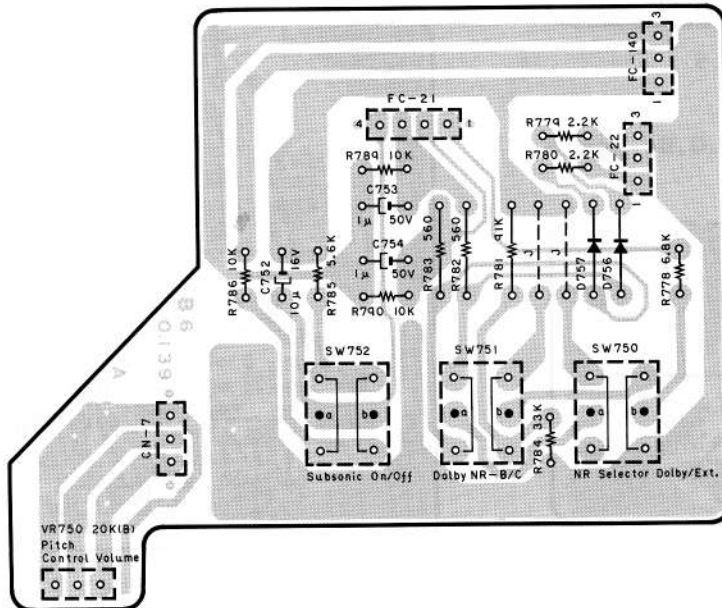

Fig. 7.14

7.15. Control Switch P.C.B. Ass'y

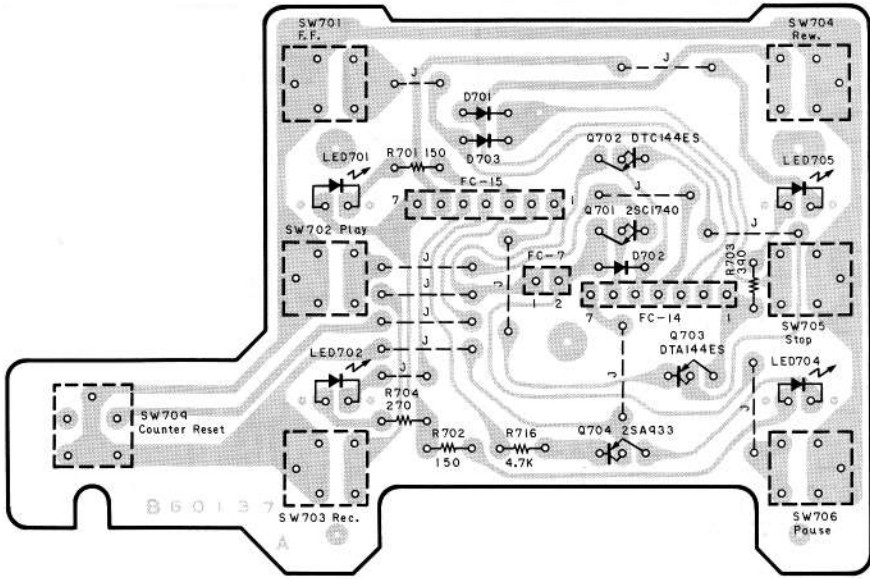

Fig. 7.15

7.16. Counter P.C.B. Ass'y

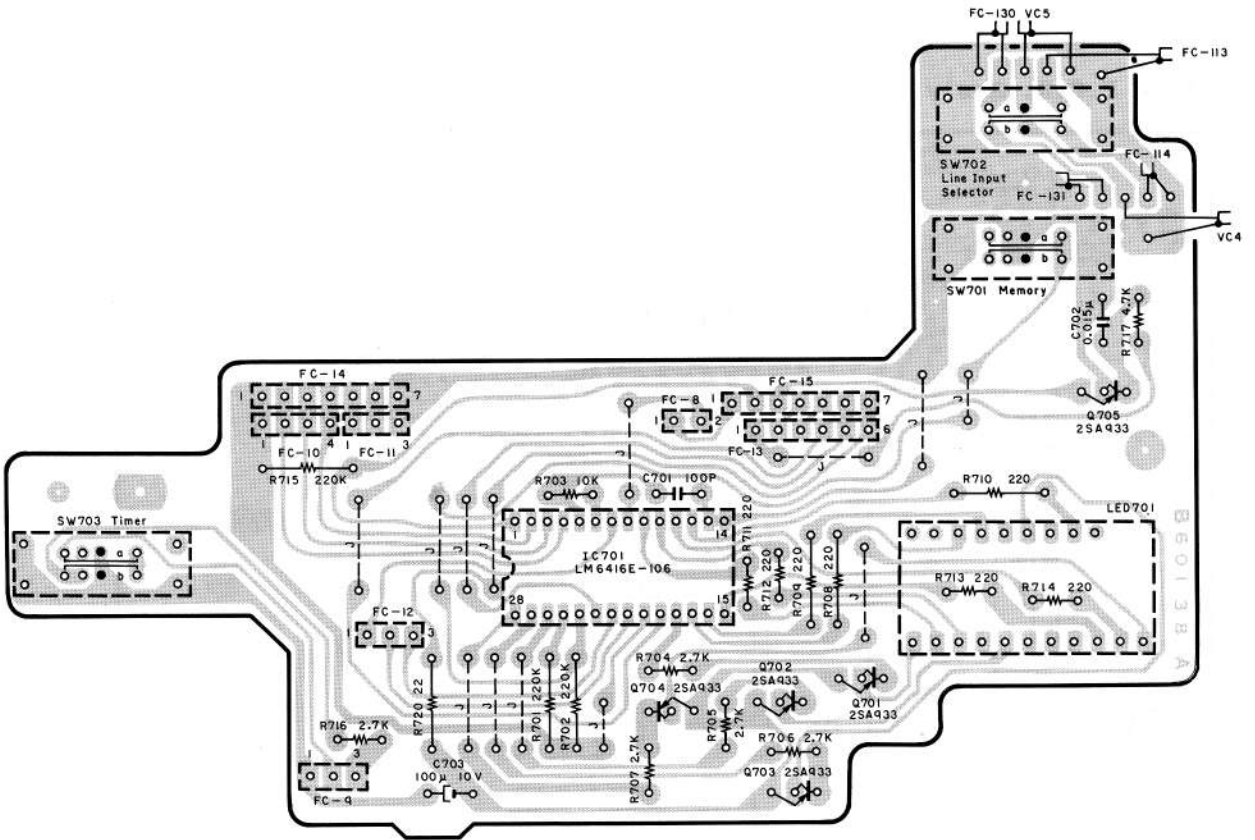

Fig. 7.16

7.17. Tape Switch P.C.B. Ass'y

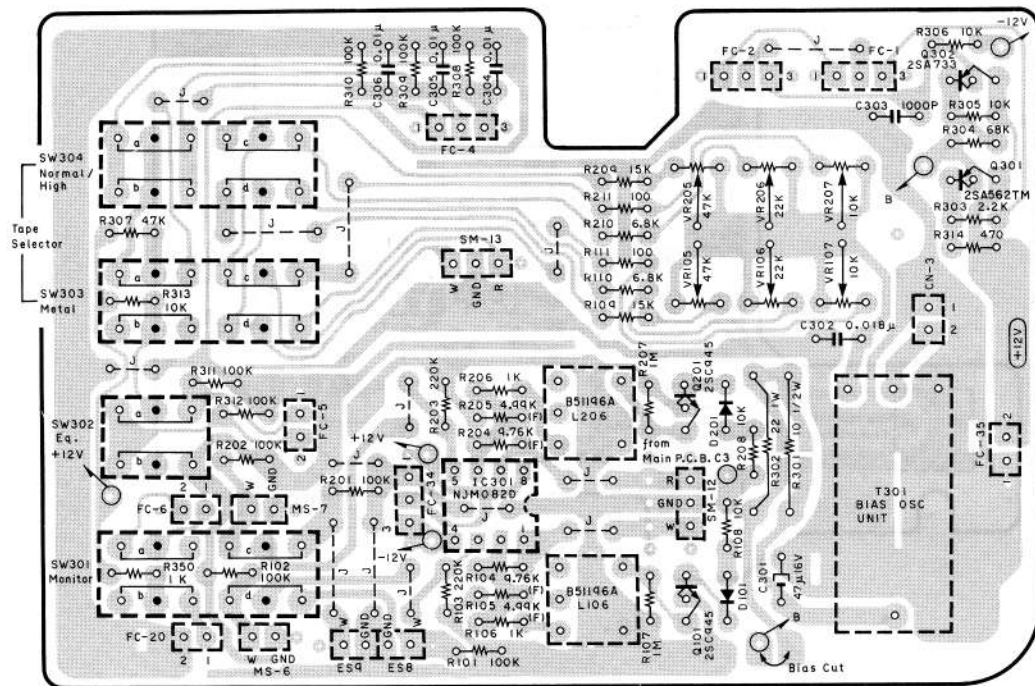

Fig. 7.17

7.18. Fuse P.C.B. Ass'y

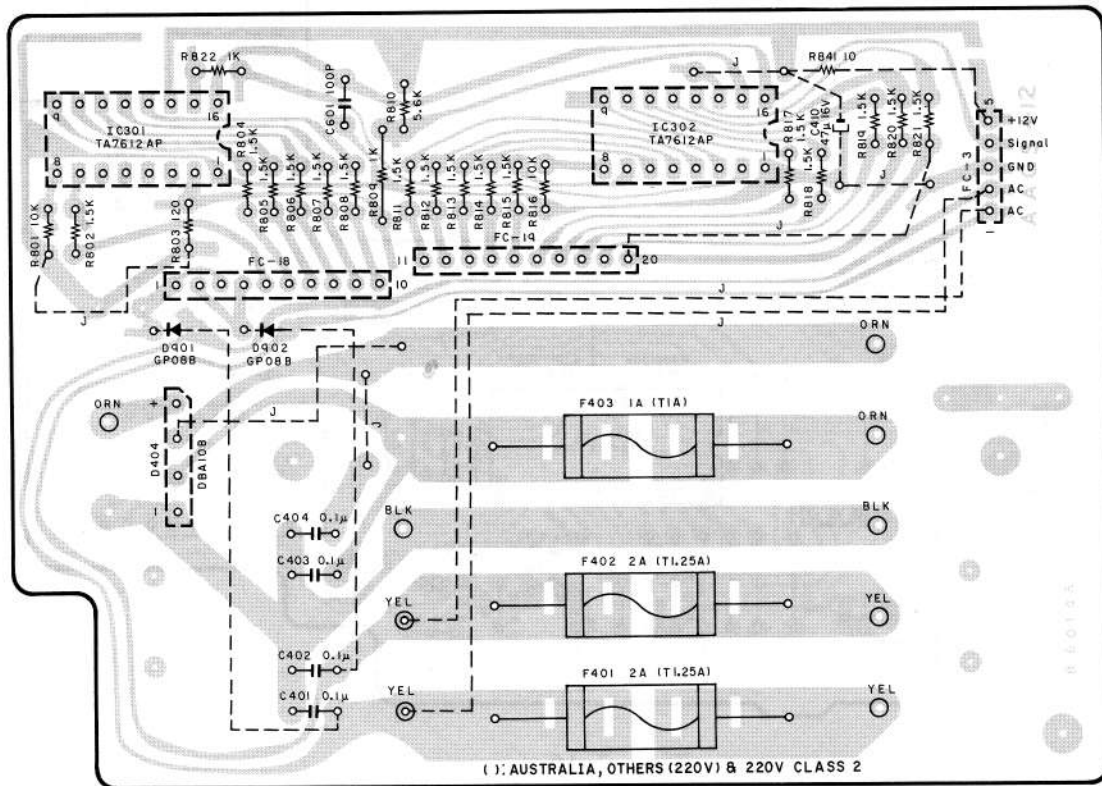

Fig. 7.18

7.19. Main P.C.B. Ass'y

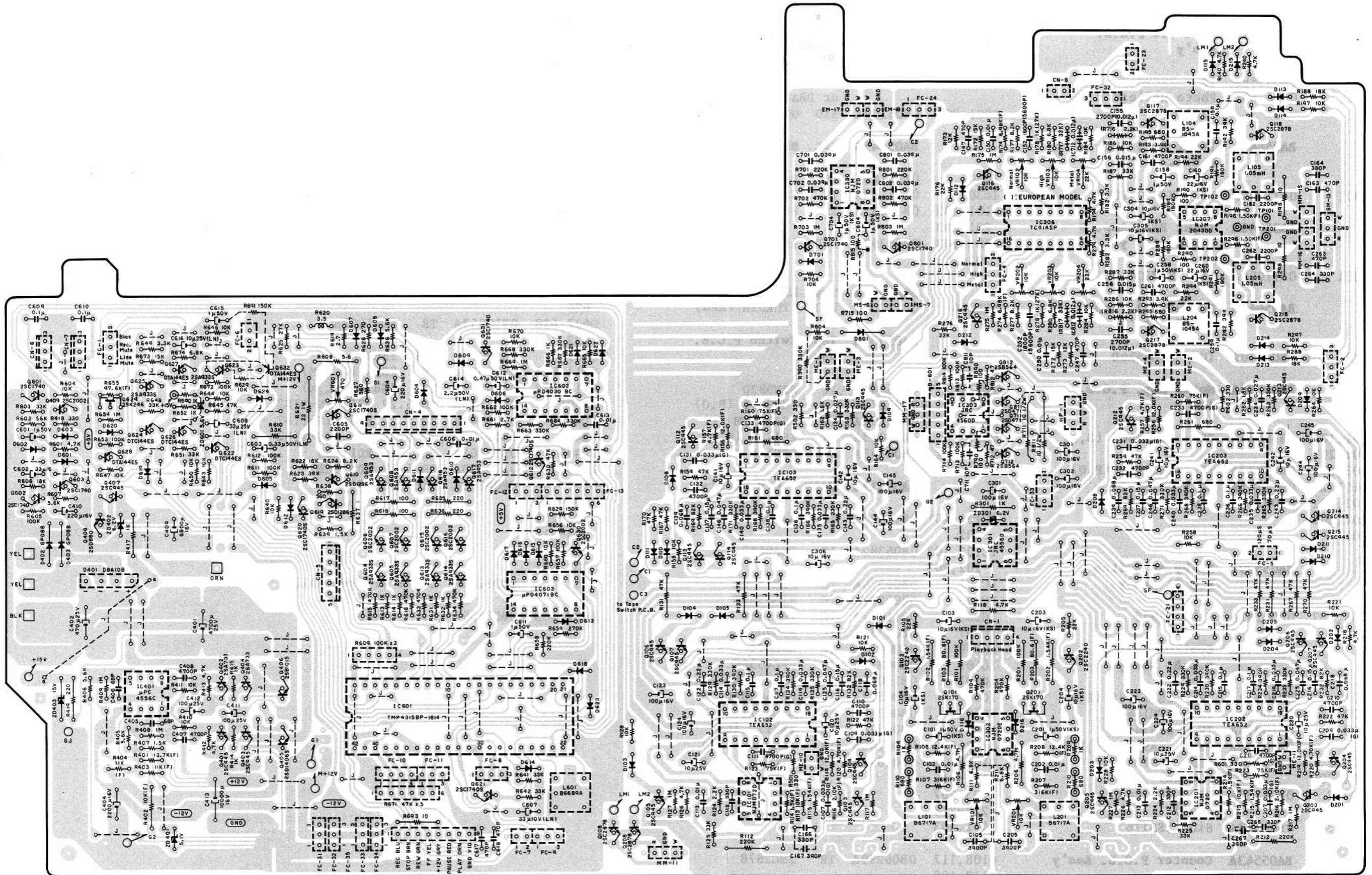

Fig. 7.19

8. SCHEMATIC DIAGRAM

8.1. Schematic Diagram

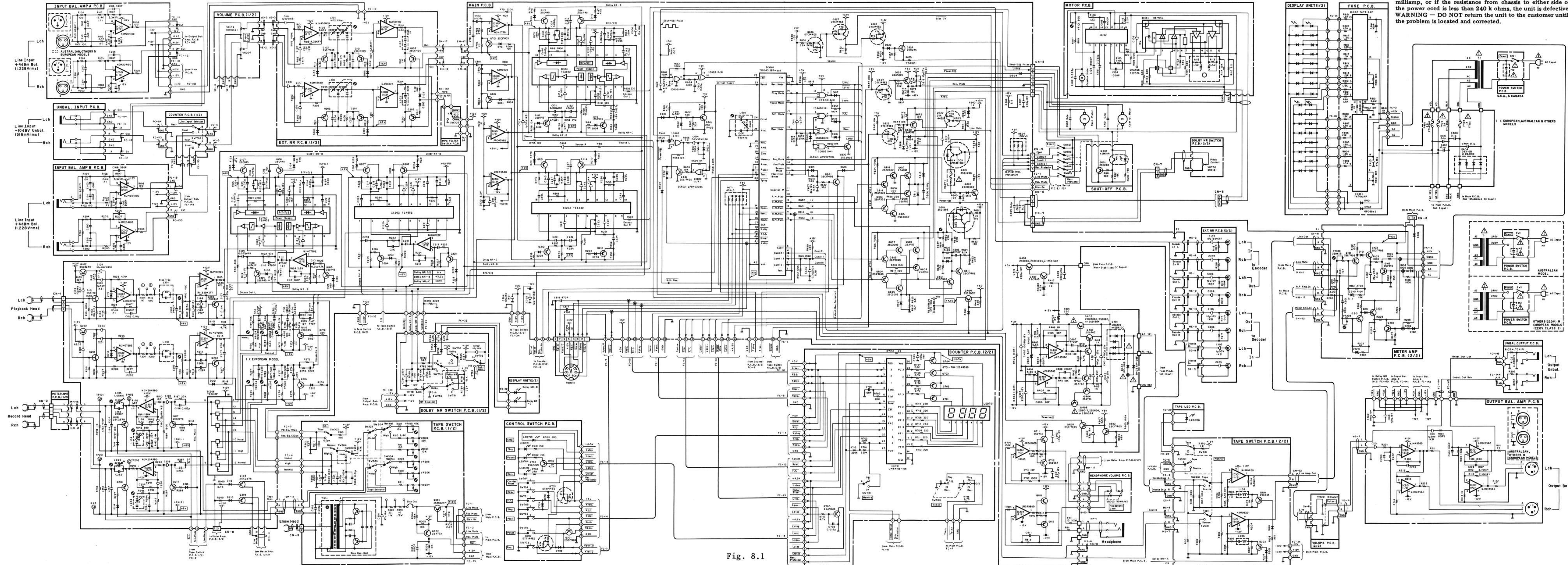



Fig. 8.1

Warning:
Parts marked with the symbol  have critical characteristics. Use ONLY replacement parts recommended by the manufacturer.

It is recommended that the unit be operated from a suitable DC supply or batteries during initial check-out procedure.

Caution:
Before returning the unit to the customer, make sure you make either (1) a leakage current check or (2) a line to chassis resistance check. If the leakage current exceeds 0.5 milliamp, or if the resistance from chassis to either side of the power cord is less than 240 k ohms, the unit is defective. **WARNING - DO NOT** return the unit to the customer until the problem is located and corrected.

- Notes:
1. Diode is 1SS53, 1S1555, or 1SS176 unless otherwise specified.
 2. 2SA733, 2SA608SP, 2SA1048 and 2SA1175 are interchangeable with each other.
 3. 2SC945, 2SC536SP, 2SC2458 and 2SC2785 are interchangeable with each other.

8.2. IC Block Diagrams

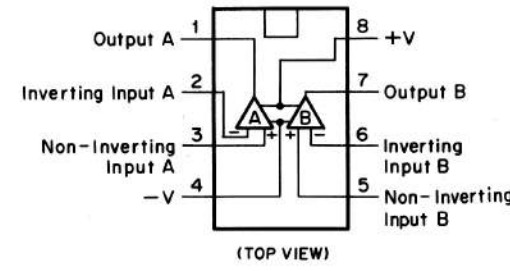

Fig. 8.1.1 Operational Amp. IC 4558DD, 072D, 072DE, 4556D, 4556C, 4560D, 2041DD, 2043DD, 082D

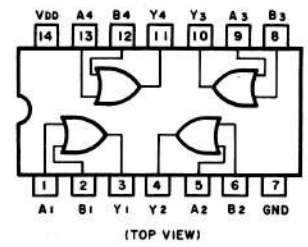

Fig. 8.1.2 OR Gate C-MOS IC μPD4071BC

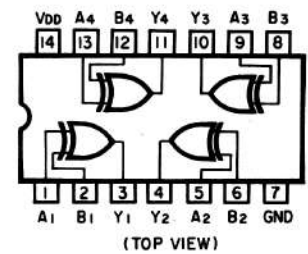

Fig. 8.1.3 Exclusive OR Gate C-MOS IC μPD4030BC

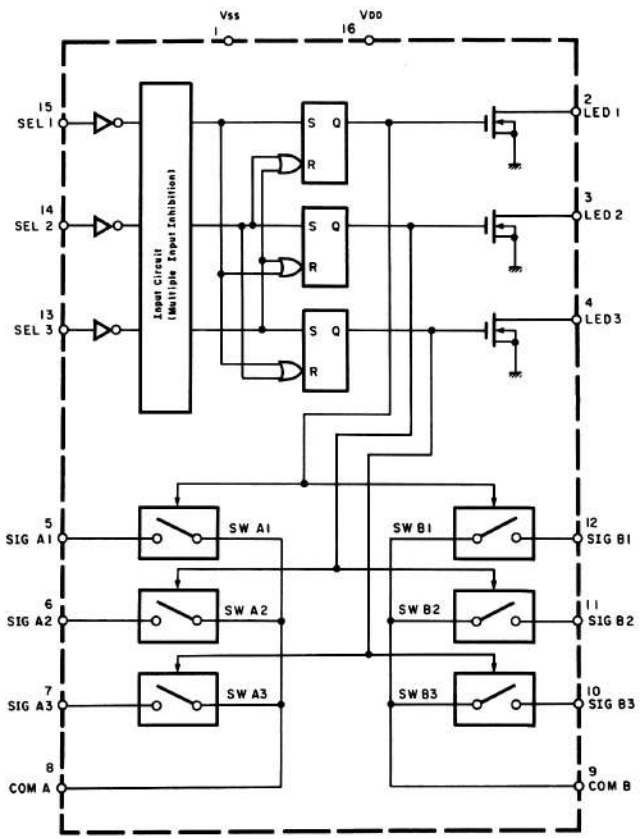

Fig. 8.1.4 Analog Switch Selector TC9145P

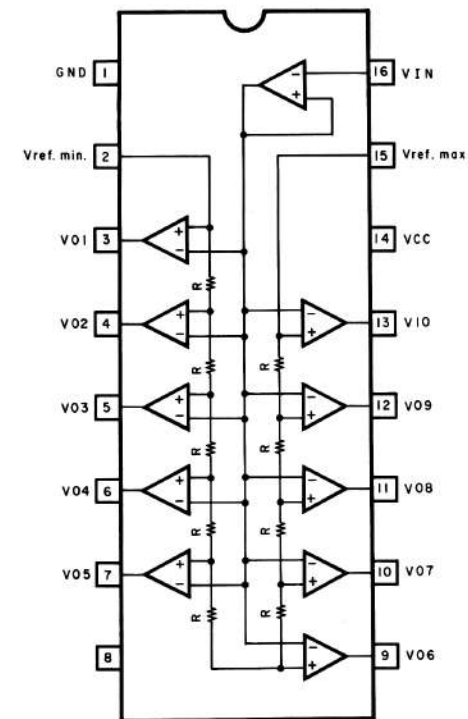

Fig. 8.1.5 Level Meter Driver TA7612AP

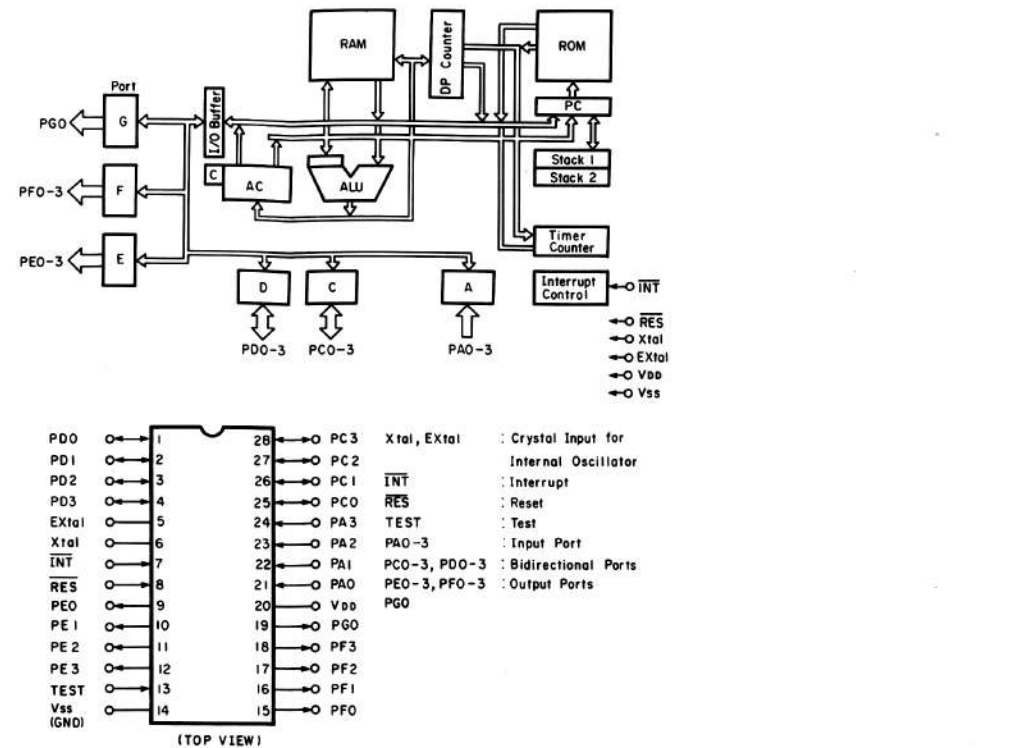

Fig. 8.1.6 4-Bit Micro-processing Unit LM6416E-106

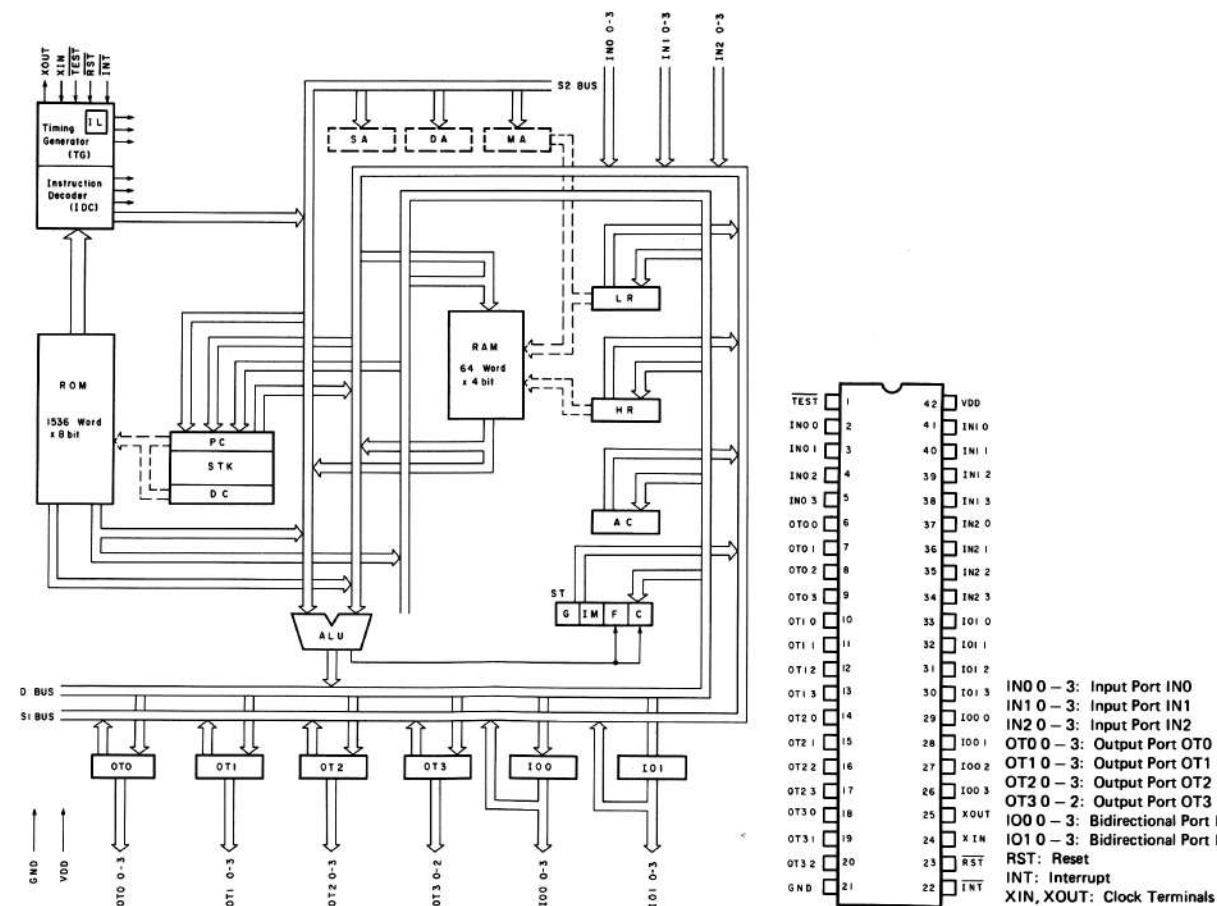

Fig. 8.1.7 4-Bit Micro-processing Unit TMP4315BP-1814

9. TIMING CHART AND EQ. AMP. FREQUENCY RESPONSE

9.1. Timing Chart

(1) Overall Timing Chart

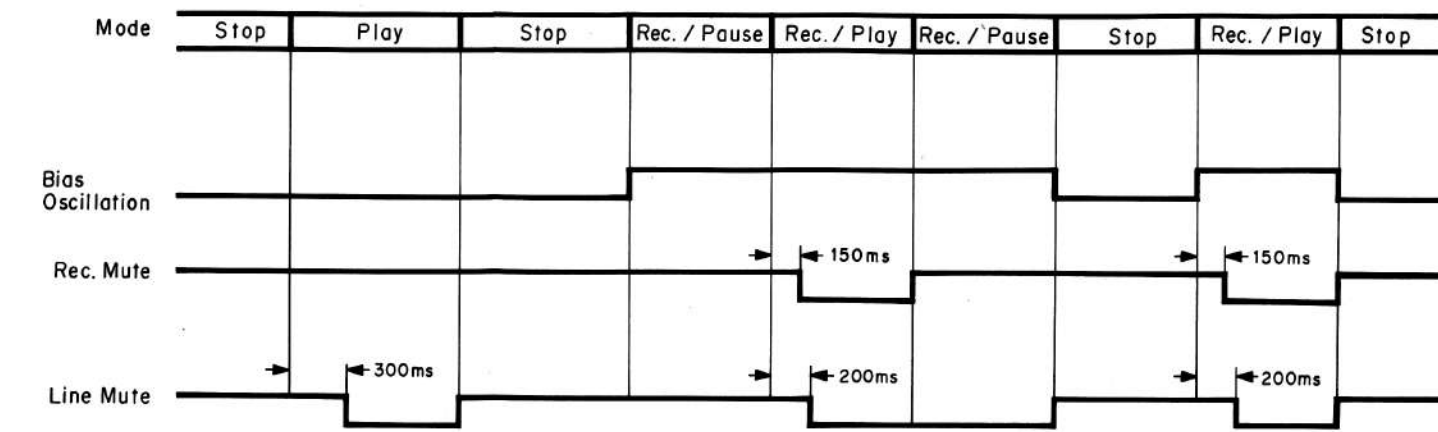

Fig. 9.1.1

(2) Mechanism Control Timing Chart

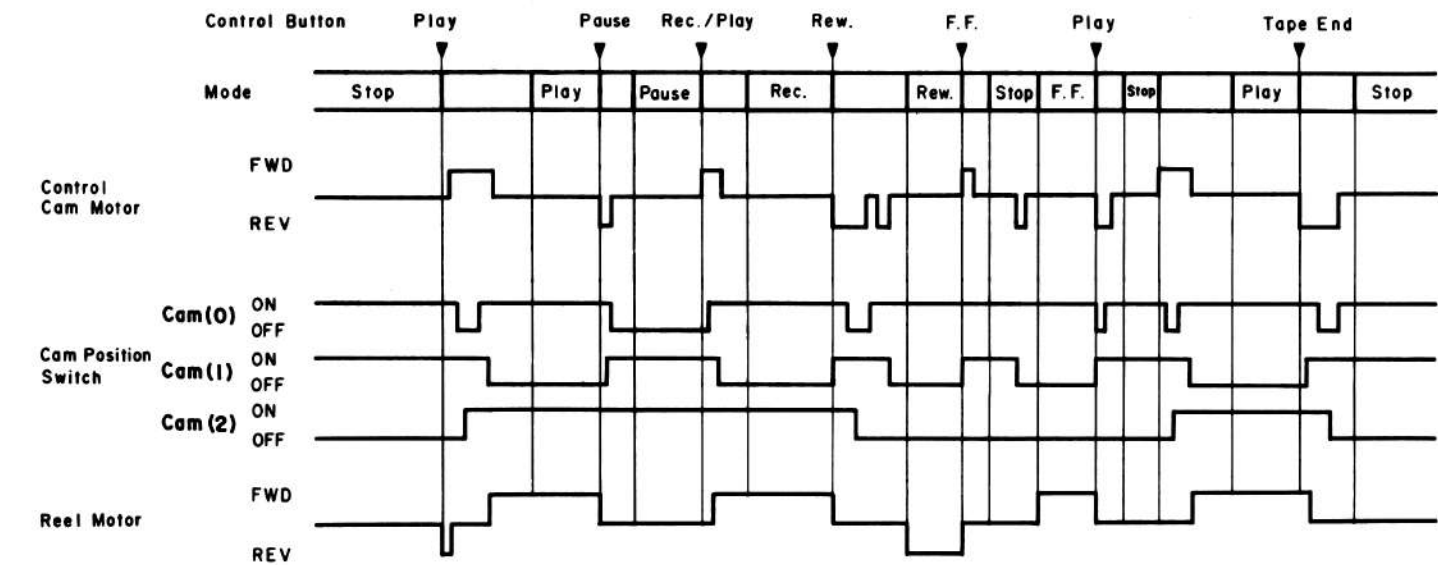

Fig. 9.1.2

9.2. Eq. Amp. Frequency Response
(1) Playback Frequency Response

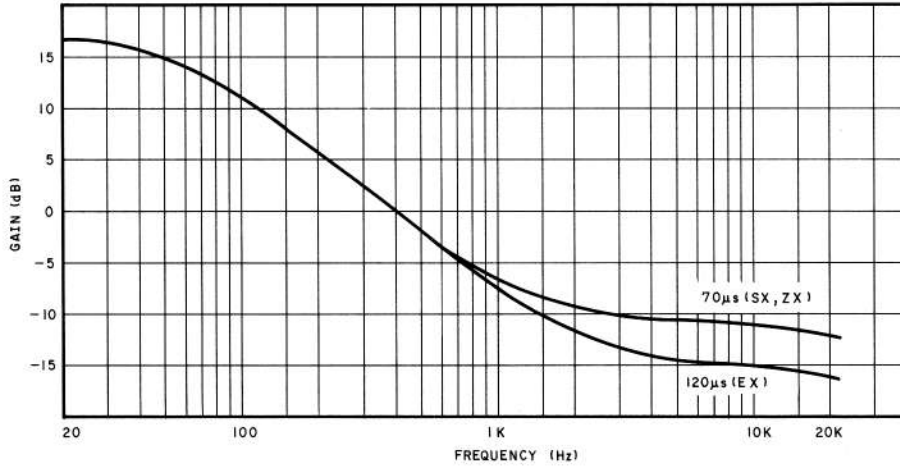

Fig. 9.2.1

(2) Record Current Frequency Response

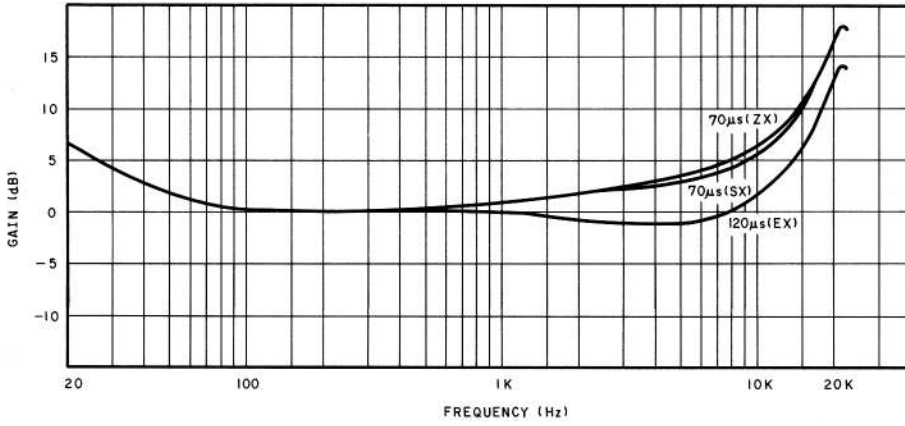

Fig. 9.2.2

10. BLOCK DIAGRAMS

10.1. Amplifier Section

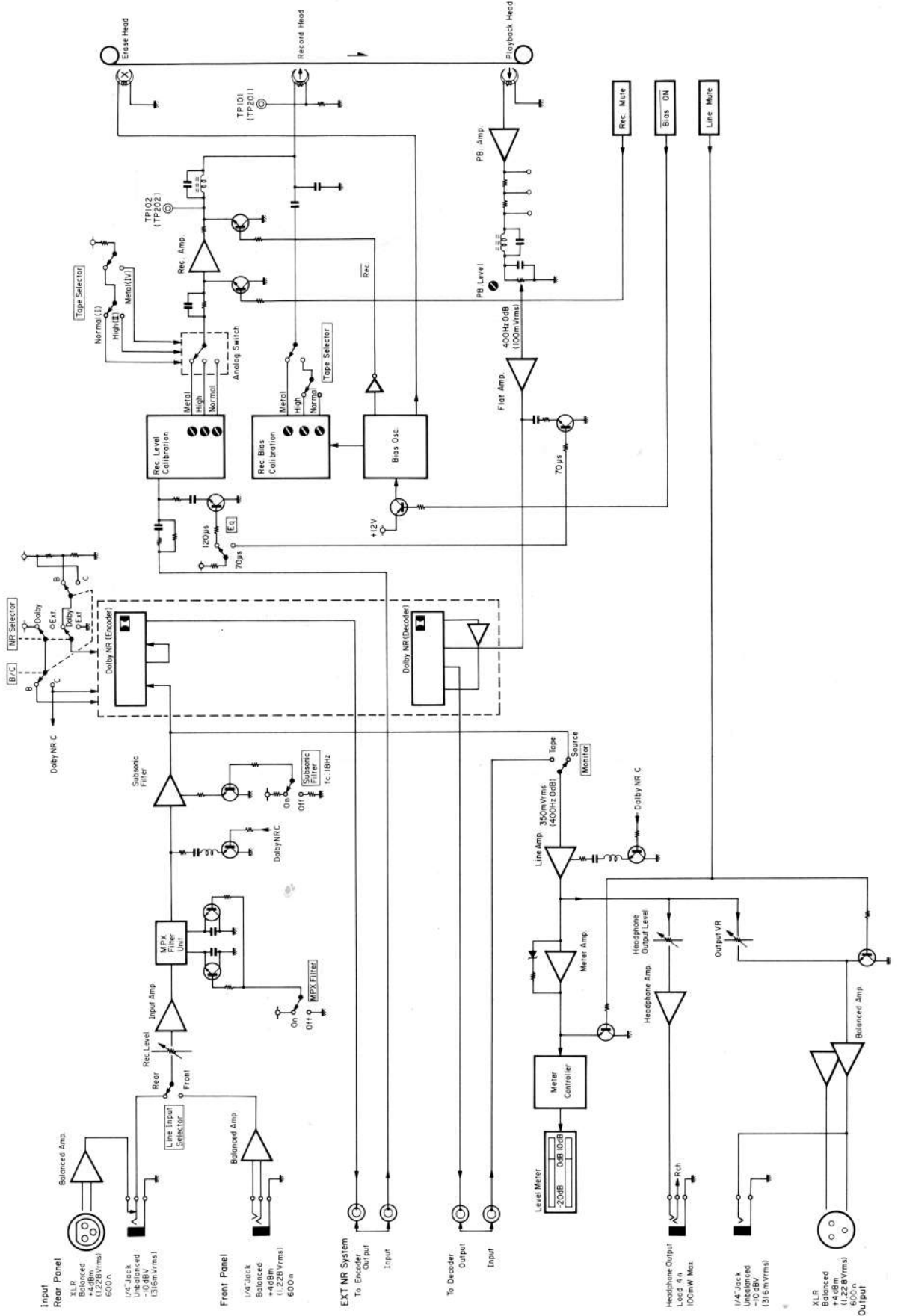

Fig. 10.1

10.2. Mechanism Control Section

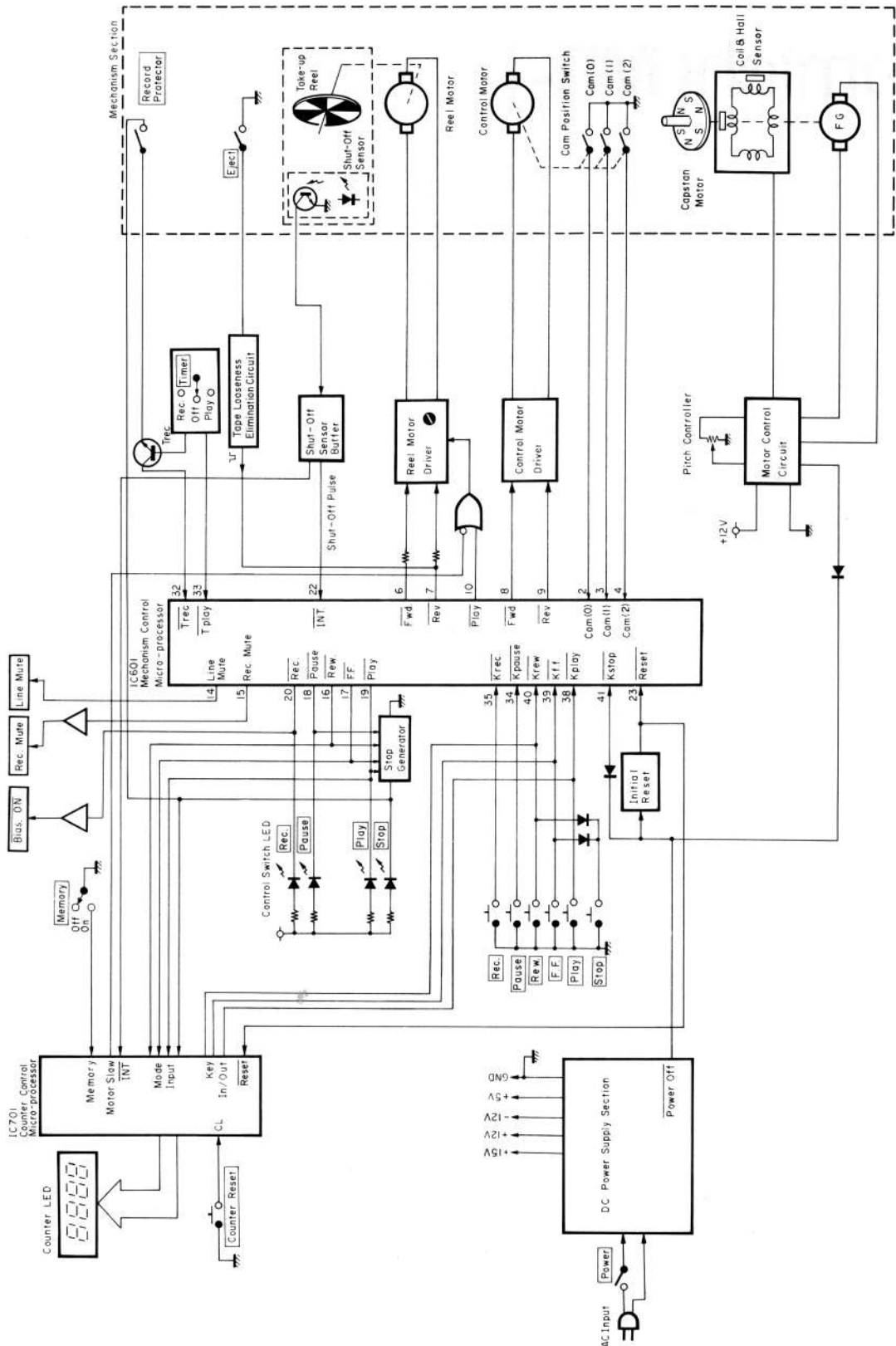

Fig. 10.2

- Notes: 1. Noise Reduction System manufactured under license from Dolby Laboratories Licensing Corporation.
 2. The word "DOLBY" and the Double-D-Symbol are trademarks of Dolby Laboratories Licensing Corporation.

This page intentionally left blank.

Model Nakamichi MR-1 (Discrete Head
Professional Cassette Deck)

Subject Service Manual Supplement



Date 12 July 1985

1. Introduction

This supplement consists of the following items:

- o Information about Australia, Others (220V fixed) and 220V Class 2 Versions
- o Parts list of electrical components on P.C.B. ass'y
- o Wiring diagram

2. Information about Australia, Others (220 V fixed) and 220V Class 2 Versions

As the separate-volume Service Manual is prepared for only U.S.A. and Canada versions, this supplement is issued to inform about Australia, Others (220V fixed) and 220V Class 2 versions.

However, refer to the Service Manual together with this supplement as only differences from U.S.A. and Canada versions are stated in this supplement.

2.1. Packing Materials and Owner's Manual

Refer to the Service Manual. The following is added:

<u>Part No.</u>	<u>Description</u>	<u>Q'ty</u>
OD04574A	Owner's Manual Supplement	1

2.2. Test Tapes and Gauges

Refer to the Service Manual. The following is required for 220V Class 2 version.

- o Reference SX-E Tape (DA09086A) for High position

2.3. Mechanical Adjustments

Refer to the Service Manual.

2.4. Parts Location for Electrical Adjustment

Refer to the Service Manual.

2.5. Electrical Adjustments

Refer to the Service Manual. However, use a reference SX-E tape instead of a reference SX tape for 220V Class 2 version.

2.6. Mechanism Ass'y and Parts List

Refer to the Service Manual. The following parts are different from U.S.A. and Canada versions.

(1) Synthesis

Stays the same.

(2) Front Panel Ass'y (A01)

Stays the same.

(3) Synthesis Mechanism Ass'y (A02)

<u>Ref. No.</u>	<u>Part No.</u>	<u>Description</u>	<u>Q'ty</u>
15	BA05541A	Power Switch P.C.B. Ass'y	1
26	BA05517A	Main P.C.B. Ass'y (Australia & Others)	1
	BA05517A-E	Main P.C.B. Ass'y (220V Class 2)	1
27	HA04725A	Rear Panel Ass'y (Australia)	1
	HA04726A	Rear Panel Ass'y (220V Class 2 & Others)	1
-	OB02240A	Fuse T1.25A	2
-	OB08347U	Fuse T1A	1
-	OB08349B	Fuse Clip	6

(4) Front Chassis Ass'y (B01)

Stays the same.

(5) Cover Plate Ass'y (B02)

Stays the same.

(6) Mechanism Ass'y (B03)

Stays the same.

(7) Rear Panel Ass'y (B04)

<u>Ref. No.</u>	<u>Part No.</u>	<u>Description</u>	<u>Q'ty</u>
B04	HA04725A	Rear Panel Ass'y (Australia)	1
	HA04726A	Rear Panel Ass'y (220V Class 2 & Others)	1
03	BA05842A	Input Bal. Amp. A P.C.B. Ass'y	1
06	BA05841A	Output Bal. Amp. P.C.B. Ass'y	1
09	OB50036B	Power Transformer 220/240V	1
10	OB08037U	Cord Bushing C 4P-4	1
11	OB05241A	Power Cord (Australia)	1
	OB08093U	Power Cord (220V Class 2 & Others)	1

2.7. Mounting Diagrams

Refer to the Service Manual.

2.8. Schematic Diagram

Refer to the Service Manual.

2.9. Timing Chart and Eq. Amp. Frequency Response

Refer to the Service Manual.

2.10. Block Diagram

Refer to the Service Manual.

3. Parts List of Electrical Components on P.C.B. Ass'y

Notes:

1. Diode is 1SS53, 1S1555, or 1SS176 unless otherwise specified.
2. Following transistors are interchangeable with each other.
 - a. 2SA733, 2SA608SP, 2SA1048, 2SA1175
 - b. 2SC945, 2SC536SP, 2SC2458, 2SC2785
3. Abbreviation for part name:

TR - Transistor, SiD - Silicon Diode, ZD - Zener Diode
 RK - Carbon Resistor, RM - Metal Film Resistor, RF - Fail Safe Type Resistor
 CE - Electrolytic Capacitor, CM - Mylar Capacitor, CC - Ceramic Capacitor,
 CP - PP Capacitor, CT - Tantalum Capacitor, CF - Film Capacitor,

Schematic Ref. No.	Part No.	Description	Schematic Ref. No.	Part No.	Description	Schematic Ref. No.	Part No.	Description
	BA05537A	Set-A P.C.B. Ass'y (U.S.A., Canada, Australia & Others)		BA05540A	Power Switch P.C.B. Ass'y (U.S.A. & Canada)		BA05544A	Volume P.C.B. Ass'y
	BA05517A	Main P.C.B. Ass'y	SW1 M2	OB60140A	Power Switch P.C.B.	VR109,209 VR301	OB60135A	Volume P.C.B.
	BA05525A	Meter Amp. P.C.B. Ass'y		OB70002A	Power Switch		OB31002A	VR 100K (A)
	BA05530A	Tape Switch P.C.B. Ass'y		OB08342A	Spark Killer		OB31001A	VR 10K (A)x2
	BA05544A	Volume P.C.B. Ass'y		OJ04763A	Power Switch Holder (1)		OB81011A	Dip Mate 4P (1)
	BA05649A	Tape LED P.C.B. Ass'y		OE00752A	Eyelet 2x3 (2)		OB81012A	Dip Mate 5P (1)
	BA05650A	MPX Filter Switch P.C.B. Ass'y		OE00612A	M3x6 ⊕ Pan (2A) (2)		OB02349A	JP Connector 4P (1)
	BA05537A-E	Set-A P.C.B. Ass'y (220V Class 2)		BA05541A	Power Switch P.C.B. Ass'y (Australia, 220V Class 2 & Others)		BA05644A	Input Bal. Amp. A P.C.B. Ass'y (U.S.A. & Canada)
	BA05517A-E	Main P.C.B. Ass'y	SW1 M2	OB60140A	Power Switch P.C.B.	IC301 R101,201 R102,104 108,202 204,208 R103,105 203,205 R106,107 206,207 C101,103 201,203 C105,106 205,206	OB11004A	IC NJM2041DD
	BA05525A	Meter Amp. P.C.B. Ass'y		OB70002A	Power Switch		OB22630A	RM 604 1/4W F
	BA05530A	Tape Switch P.C.B. Ass'y		OB08445A	Spark Killer		OB09653A	RK 100 1/6W J
	BA05544A	Volume P.C.B. Ass'y		OJ04763A	Power Switch Holder (1)		OB22353A	RM 12.4K 1/6W F
	BA05649A	Tape LED P.C.B. Ass'y		OB90059A	Spark Killer Cover (1)		OB22286A	RM 3.3K 1/6W F
	BA05650A	MPX Filter Switch P.C.B. Ass'y		OE00752A	Eyelet 2x3 (2)		OB41386A	CP 100P 50V J
			OE00612A	M3x6 ⊕ Pan (2A) (2)	OB09323A	CP 560P 100V J		
	BA05538A	Set-B P.C.B. Ass'y		CA80011A	Shut-off P.C.B. Ass'y		OB02348A	JP Connector 3P (1)
	BA05529B	Dolby NR Switch P.C.B. Ass'y	Q601 Q602	OC80047A	Shut-off P.C.B. TR 2SC2812		OB81002A	Dip Mate 2P (1)
	BA05645A	Ext. NR P.C.B. Ass'y		OB06388A	Photo Reflector NJM5141		OB81014A	Dip Mate 7P (1)
	BA05546B	Fuse P.C.B. Ass'y	R601 R602 R603	OB09840A	RK 680		OB81343A	Connector XLB-3-31PCV (2)
				OB09841A	RK 18K		OE00792A	M2.6x6 ⊕ Pan (4)
				OC81330A	RM 750			
				BA05649A	Tape LED P.C.B. Ass'y		BA05842A	Input Bal. Amp. A P.C.B. Ass'y (Australia, 220V Class 2 & Others)
			LED706 FC20	OB60199A	Tape LED P.C.B.	IC301 R101,201 R102,104 108,202 204,208 R103,105 203,205 R106,107 206,207 C101,103 201,203 C105,106 205,206	OB60194A	Input Bal. Amp. A P.C.B.
				OB12258A	LED Red TLR102A		OB11004A	IC NJM2041DD
				OB81065A	Wire Mate 2P		OB22630A	RM 604 1/4W F
				BA05650A	MPX Filter Switch P.C.B. Ass'y		OB09653A	RK 100 1/6W J
			R301 SW305 FC24 FC102	OB60200A	MPX Filter Switch P.C.B.		OB22353A	RM 12.4K 1/6W F
				OB09693A	RK 4.7K 1/6W J		OB22286A	RM 3.3K 1/6W F
				OB70039A	Slide Switch	OB41386A	CP 100P 50V J	
				OB81010A	Dip Mate 3P	OB09323A	CP 560P 100V J	
				OB81002A	Dip Mate 2P		OB02348A	JP Connector 3P (1)
				BA05547A	Headphone Volume P.C.B. Ass'y		OB81002A	Dip Mate 2P (1)
				OB60202A	Headphone Volume P.C.B.		OB81014A	Dip Mate 7P (1)
				OB30020A	Volume 50K (A)x2		OB81344A	Connector XLB-3-32PCV (2)
				OJ04842C	Holder (1)		OE00792A	M2.6x6 ⊕ Pan (4)

Schematic Ref. No.	Part No.	Description	Schematic Ref. No.	Part No.	Description	Schematic Ref. No.	Part No.	Description
IC301 R101,201 R102,104 108,202 204,208 R103,105 203,205 R106,107 206,207 C101,103 201,203 C105,106 205,206 FC130,131 141	BA05646A	Input Bal. Amp. B P.C.B. Ass'y	IC101,201 R101,201 R102,103 202,203 R111,122 211,222 R112,113 212,213 R114,214 C101,201 C104,105 204,205 C301,302 FC144,145	BA05841A	Output Bal. Amp. P.C.B. Ass'y (Australia, 220V Class 2 & Others)	Q101,102 201,202 Q103,203 ZD101,201 D101,102 201,202 303 VR108,208 R101,201 R102,202 R103,203 R104,204 R105,106 108,109 205,206 208,209 R107,207 R190,290 C101,201 C102,202 CN2 CN8 FC3 MM15/16	BA05525A	Meter Amp. P.C.B. Ass'y
	OB60196A	Input Bal. Amp. B P.C.B.		OB60193A	Output Bal. Amp. P.C.B.		OB60136A	Meter Amp. P.C.B.
	OB11004A	IC NJM2041DD		OB06370A	IC NJM4556D		OB10039A	TR 2SC1740S (S,E)
	OB22630A	RM 604 1/4W F		OB22229A	RM 1K 1/6W F		OB01872A	TR 2SC945L (P,Q)
	OB09653A	RK 100 1/6W J		OB09725A	RK 100K 1/6W J		OB12101A	ZD 5V 5C-1
	OB22353A	RM 12.4K 1/6W F		OB05923A	RF 47 1/4W J		OB06398A	SiD 1SS176
	OB22286A	RM 3.3K 1/6W F		OB22263A	RM 2.1K 1/6W F		OB32026A	Semi-fixed VR 220K
	OB41386A	CP 100P 50V J		OB09677A	RK 1K 1/6W J		OB09703A	RK 12K 1/6W J
	OB09323A	CP 560P 100V J		OB09814A	CE 1μ 50V (KS)		OB01889A	RK 100K 1/4W J
	OB81014A	Dip Mate 7P (1)		OB41386A	CP 100P 50V J		OB09735A	RK 270K 1/6W J
OB81289A	1/4 Inch Jack (2)	OB01400A	CE 100μ 16V	OB09704A	RK 13K 1/6W J			
FC111-114	BA05647A	Unbal. Input P.C.B. Ass'y	OE00792A	OB02349A	JP Connector 4P (1)	OB09725A	RK 100K 1/6W J	
	OB60197A	Unbal. Input P.C.B. JP Connector 8P (1)		OB02348A	JP Connector 3P (1)	OB09685A	RK 2.2K 1/6W J	
	OB81396A	1/4 Inch Jack (2)		OB81002A	Dip Mate 2P (2)	OB09868A	CF 0.1μ 50V J	
	OB81289A	1/4 Inch Jack (2)		OB81010A	Dip Mate 3P (2)	OB09137A	CE 22μ 25V (LN)	
R102,202 R103,203 FC144,145	BA05648A	Unbal. Output P.C.B. Ass'y	BA05645A	Ext. NR P.C.B. Ass'y	D756,757 VR750 R778 R779,780 R781 R782,783 R784 R785 R786,789 790 C752 C753,754 SW751-753	BA05529B	Dolby NR Switch P.C.B. Ass'y	
	OB60198A	Unbal. Output P.C.B. RM 4.99K 1/6W F		OB60195A		Ext. NR P.C.B.	OB60139A	Dolby NR Switch P.C.B.
	OB22308A	RM 4.7K 1/6W F		OB06146A		IC NJM4558DD	OB06181A	SiD 1SS53
	OB22305A	RM 4.7K 1/6W F		OB06457A		IC NJM072	OB30019A	VR 20K (B)
OB81011A	Dip Mate 4P (1)	OB10033A	TR 2SC1740S (S)	OB09697A	RK 6.8K 1/6W J			
OB81289A	1/4 Inch Jack (2)	OB06398A	SiD 1SS176	OB09685A	RK 2.2K 1/6W J			
IC101,201 R101,201 R102,103 202,203 R111,122 211,222 R112,113 212,213 R114,214 C101,201 C104,105 204,205 C301,302 FC144/145	BA05643A	Output Bal. Amp. P.C.B. Ass'y (U.S.A. & Canada)	IC301 IC302 Q101-103 201-203 D101-103 201-203 L101,201 L102,202 R101,201 R102,202 R103,203 R105,205 R106,206 R107,207 R108,109 113,208 209,213 R110,111 114,210 211,214 R112,212 R115,215 R117,118 119,217 218,219 C101,105 201,205 C102,202 C103,203 C104,204 C106,107 108,206 207,208	OB06690A	L-C Block (Blue)	FC21	BA05542A	Control Switch P.C.B. Ass'y
	OB60193A	Output Bal. Amp. P.C.B.		OB06691A	L-C Block (Yellow)		OB60137A	Control Switch P.C.B.
	OB06370A	IC NJM4556D		OB09653A	RK 100 1/6W J		OB10039A	TR 2SC1740S (S,E)
	OB22229A	RM 1K 1/6W F		OB09725A	RK 100K 1/6W J		OB10062A	TR DTC144ES
	OB09725A	RK 100K 1/6W J		OB22229A	RM 1K 1/6W F		OB10053A	TR DTA144ES
	OB05923A	RF 47 1/4W J		OB22301A	RM 4.32K 1/6W F		OB10026A	TR 2SA933S (Q,R,S)
	OB22263A	RM 2.1K 1/6W F		OB22275A	RM 2.67K 1/6W F		OB06334A	LED Green TLG124A
	OB09677A	RK 1K 1/6W J		OB22315A	RM 5.62K 1/6W F		OB06333A	LED Red TLR124A
	OB09814A	CE 1μ 50V (KS)		OB09749A	RK 1M 1/6W J		OB12101A	SiD 1SS176
	OB41386A	CP 100P 50V J		OB09689A	RK 3.3K 1/6W J		OB05795A	RK 150 1/4W J
OB01400A	CE 100μ 16V	OB09701A	RK 10K 1/6W J	OB09657A	RK 150 1/6W J			
OB02349A	JP Connector 4P (1)	OB09677A	RK 1K 1/6W J	OB09667A	RK 390 1/6W J			
OB02348A	JP Connector 3P (1)	OB01889A	RK 100K 1/4W J	OB09663A	RK 270 1/6W J			
OB81002A	Dip Mate 2P (2)	OB09814A	CE 1μ 50V (KS)	OB09693A	RK 4.7K 1/6W J			
OB81010A	Dip Mate 3P (2)	OB09932A	CE 22μ 16V (KS)	OB70004A	Touch Switch			
OB81344A	Connector XLB-3-32PCV (2)	OB05687A	CM 1200P 50V J	OJ04744B	LED Reflector (4)			
OE00792A	M2.6x6 ⊕Pan (4)	OB09189A	CM 2700P 50V J					
		C106,107	CE 10μ 16V (KS)					
		108,206	JP Connector 4P (6)					
		207,208	Wire Trap 2P (2)					
			4P Pin Jack (2)					

Schematic Ref. No.	Part No.	Description	Schematic Ref. No.	Part No.	Description
	BA05543A	Counter P.C.B. Ass'y		BA05546B	Fuse P.C.B. Ass'y
IC701	OB60138A	Counter P.C.B.	IC301,302	OB60141A	Fuse P.C.B.
Q701-705	OB06368A	IC LM6416E-106	D404	OB06369A	IC TA7612AP
R701,702	OB05625A	TR 2SA933S	D901,902	OB06282A	Diode Bridge DBA10
715		(Q,R,S)	R801,816	OB06109A	SiD GP08B
R703	OB09701A	RK 220K 1/4W J	R802	OB09701A	RK 10K 1/6W J
R704-707	OB09687A	RK 10K 1/6W J	804-808	OB09681A	RK 1.5K 1/6W J
R708,709	OB09661A	RK 2.7K 1/6W J	811-815		(16)
710		(5)	817-821		
R711,712	OB01933A	RK 220 1/6W J	R803	OB09655A	RK 120 1/6W J
713,714			R809,822	OB09677A	RK 1K 1/6W J
R717	OB09693A	RK 220 1/4W J	R810	OB09695A	RK 5.6K 1/6W J
R720	OB05579A	RK 22 1/4W J	R841	OB05936A	RK 10 1/4W J
C701	OB09282A	CC 4.7K 1/6W J	C401-404	OB09292A	CC 0.1μ 50V Z
C702	OB05557A	RK 22 1/4W J	C410	OB09218A	CE 47μ 16V (LN)
C703	OB05885A	CC 100P 50V K	C601	OB09282A	CC 100P 50V K
SW701,702	OB70010A	CM 0.015μ 50V J	FC3	OB02350A	JP Connector 5P
SW703	OB07437A	CE 100μ 10V	FC18,19	OB02355A	JP Connector 10P
		Slide Switch			
		Slide Switch			
		Socket 9P (1)			
		Socket 11P (1)			
	BA05530A	Tape Switch P.C.B. Ass'y			
IC301	OB60134A	Tape Switch P.C.B.			
Q101,201	OB06443A	IC NJM082D			
Q301	OB01872A	TR 2SC945L (P,Q)			
Q302	OB06202A	TR 2SA562TM (Y)			
D101,201	OB06013A	TR 2SA733 (P,Q)			
T301	OB06398A	SiD 1SS176			
L106,206	OB51047A	Bias Osc. Unit			
VR105,205	OB51196A	L-C Block			
VR106,206	OB32010A	Semi-fixed VR 47K			
VR107,207	OB32009A	Semi-fixed VR 22K			
R101,102	OB32008A	Semi-fixed VR 10K			
201,202	OB09725A	RK 100K 1/6W J			
308-312		(9)			
R103,203	OB09733A	RK 220K 1/6W J			
R104,204	OB22342A	RM 9.76K 1/6W F			
R105,205	OB22308A	RM 4.99K 1/6W F			
R106,206	OB09677A	RK 1K 1/6W J			
350					
R107,207	OB09749A	RK 1M 1/6W J			
R108,208	OB09701A	RK 10K 1/6W J			
305,306					
313					
R109,209	OB09705A	RK 15K 1/6W J			
R110,210	OB09697A	RK 6.8K 1/6W J			
R111,211	OB09653A	RK 100 1/6W J			
R301	OB09936A	RF 10 1/2W J			
R302	OB09831A	RF 22 1W J			
R303	OB09685A	RK 2.2K 1/6W J			
R304	OB09721A	RK 68K 1/6W J			
R307	OB09717A	RK 47K 1/6W J			
R314	OB09669A	RK 470 1/6W J			
C301	OB01403A	CE 47μ 16V			
C302	OB09538A	CP 0.018μ 100V G			
C303	OB09844A	CM 1000P 50V J			
C304,305	OB05681A	CM 0.01μ 50V J			
306					
SW301-304	OB70030A	Push Switch 5-Key			
CN3	OB81051A	(1)			
FC1,2,4,34	OB81010A	2P-S Post			
SM12,13		Dip Mate 3P (6)			
FC5,35	OB81002A	Dip Mate 2P (2)			
FC6/MS7	OB81012A	Dip Mate 5P (2)			
FC20/MS6					
ES8/9	OB81011A	Dip Mate 4P (1)			
	OJ04768B	Earth Plate A (1)			

4. Wiring Diagram

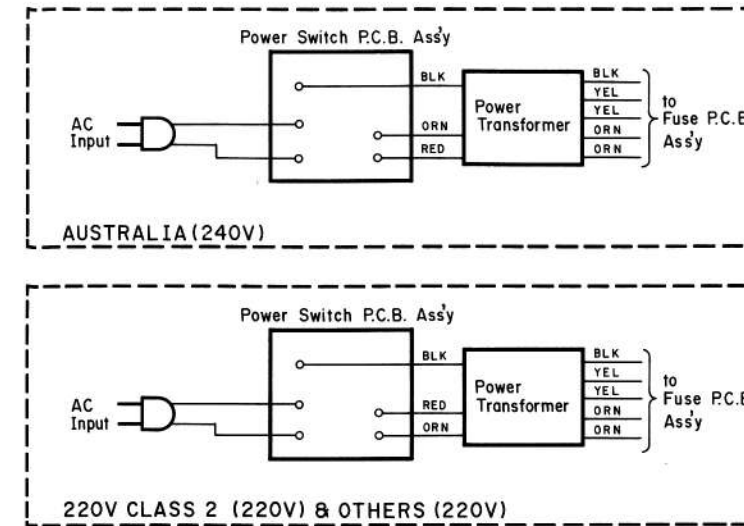

Fig. 1

- Notes: 1. Table of wire colors
 BRN - Brown BLU - Blue
 RED - Red VIO - Violet
 ORN - Orange GRY - Gray
 YEL - Yellow WHT - White
 GRN - Green BLK - Black
2. Component side view of the P.C.B. is illustrated unless otherwise specified.
3. Wire tube color is shown in ().

Schematic Ref. No.	Part No.	Description	Schematic Ref. No.	Part No.	Description
R613,614 631,632 652,666 690	OB09677A	RK 1K 1/6W J	C409 C410 C411,412	OB09798A OB40079A OB01272A	CE 6800μ 16V CE 220μ 16V CE 100μ 25V
R615,616 633,634	OB09741A	RK 470K 1/6W J	- Miscellaneous -		
R617,618	OB01679A	RK 100 1/4W J	OB60133A	Main P.C.B. (8)	
R619	OB05836A	RK 2.7 1/4W J	OB81002A	Dip Mate 2P (8)	
R620	OB06706A	R Coil 3.5	OB81011A	Dip Mate 4P (3)	
R621	OB09831A	RF 22 1W J	OB02349A	JP Connector 4P (1)	
R623	OB09715A	RK 39K 1/6W J	OB02350A	JP Connector 5P (1)	
R624	OB09699A	RK 8.2K 1/6W J	OB08584A	8P DIN Socket (1)	
R625	OB09711A	RK 27K 1/6W J	OB82402A	SCN-S Connector 8P 150mm (1)	
R627,638	OB09671A	RK 560 1/6W J	OB02348A	JP Connector 3P (1)	
R628	OB09663A	RK 270 1/6W J	OB81010A	Dip Mate 3P (13)	
R629,691	OB09729A	RK 150K 1/6W J	BA05517A-E	Main P.C.B. Ass'y (220V Class 2)	
R630,645	OB09717A	RK 47K 1/6W J	Contents is the same as for U.S.A., Canada, Australia and Others versions except for the following section.		
R635,636	OB01933A	RK 220 1/4W J	- Rec. Cal. -		
R637	OB24023A	R Fuse 1	IC306	OB11027A	IC TC9145P
R639	OB09681A	RK 1.5K 1/6W J	Q116,216	OB01872A	TR 2SC945L (P,Q)
R649	OB09689A	RK 3.3K 1/6W J	D112,212	OB06398A	SiD 1SS176
R654,669	OB09749A	RK 1M 1/6W J	VR102,103	OB32008A	Semi-fixed VR 10K
R655	OB22456A	RM 97.6K 1/6W F	VR104,204	OB32009A	Semi-fixed VR 22K
R658	OB09733A	RK 220K 1/6W J	R172,272	OB09705A	RK 15K 1/6W J
R659	OB09735A	RK 270K 1/6W J	R173,273	OB09703A	RK 12K 1/6W J
R661	OB09687A	RK 2.7K 1/6W J	R174,274	OB22326A	RM 6.98K 1/6W F
R663,664 667,668	OB09737A	RK 330K 1/6W J	R175,275	OB09749A	RK 1M 1/6W J
R671	OB09803A	R-Network 47Kx5	R176,276	OB09709A	RK 22K 1/6W J
R673	OB09705A	RK 15K 1/6W J	R177,277	OB09699A	RK 8.2K 1/6W J
R674	OB09697A	RK 6.8K 1/6W J	R178,278	OB09711A	RK 27K 1/6W J
R693	OB09216A	RF 10 1/4W J	R179,279	OB09693A	RK 4.7K 1/6W J
C601,611 615	OB01405A	CE 1μ 50V	R180,280	OB09697A	RK 6.8K 1/6W J
C602	OB40011A	CE 33μ 16V	R182,282	OB09689A	RK 3.3K 1/6W J
C603	OB40024A	CE 0.33μ 50V	R184,186	OB09701A	RK 10K 1/6W J
C604	OB40079A	CE 220μ 16V	284,286	OB09713A	RK 33K 1/6W J
C605	OB01802A	CM 2200P 50V J	R187,287	OB09685A	RK 2.2K 1/6W J
C606,613	OB09290A	CC 0.01μ 50V Z	717,817	OB09270A	CP 470P 100V J
C607	OB09817A	CE 33μ 10V (KS)	R716,816	OB05681A	CM 0.01μ 50V J
C608	OB09150A	CE 33μ 25V (LN)	C147,247	OB05659A	CM 5600P 50V J
C609,610	OB09292A	CC 0.1μ 50V Z	C150,250	OB05843A	CM 0.012μ 50V J
C612	OB40178A	CE 0.47μ 50V	C152,252		
C614	OB09332A	CE 2.2μ 50V (LN)	C155,255		
C616	OB09148A	CE 10μ 25V (LN)	712,812		
C617,618	OB09286A	CC 470P 50V K	C156,256	OB41096A	CM 0.015μ 50V J
CN4	OB02245A	9P-T Post			
CN5	OB02243A	5P-T Post			
CN6	OB08185A	3P-T Post			
CN7	OB08653A	3P-T Post			
FC7/9	OB02350A	JP Connector 5P (1)			
FC8	OB81163A	Wire Trap 2P (1)			
FC10/11	OB02352A	JP Connector 7P (1)			
FC12/13	OB02354A	JP Connector 9P (1)			
	OB90134A	Heat Sink BX			
- DC Power Supply -					
IC401	OB06216A	IC μPC4556C			
Q401,403 407	OB01872A	TR 2SC945L (P,Q)			
Q402,404 Q408	OB06013A	TR 2SA733 (P,Q)			
Q409	OB06255A	TR 2SD880 (Y)			
ZD401	OB06322A	TR 2SC2002 (K,L)			
ZD402	OB12147A	ZD 5.1V RD5.1JS-T1B2			
ZD403	OB12153A	ZD 6.2V RD6.2JS-T1B2			
D401	OB12104A	ZD 15V RD15EB3			
D402,403	OB06282A	Diode Bridge DBA10			
R401	OB06109A	SiD GP08B			
R402	OB22357A	RM 13.7K 1/6W F			
R403,404	OB09203A	RM 10K 1/4W F			
R405,406	OB22347A	RM 11K 1/6W F			
R407	OB09695A	RK 5.6K 1/6W J			
R408,409	OB09681A	RK 1.5K 1/6W J			
R410,411	OB09749A	RK 1M 1/6W J			
R412,413	OB09701A	RK 10K 1/6W J			
R414,415	OB09693A	RK 4.7K 1/6W J			
R417	OB09677A	RK 1K 1/6W J			
R418	OB01857A	RK 1K 1/4W J			
R419	OB09665A	RK 330 1/6W J			
C401	OB01933A	RK 220 1/4W J			
C402	OB40197A	CE 4700μ 25V			
C403	OB40094A	CE 470μ 25V			
C404	OB40196A	CE 10000μ 16V			
C405,406	OB40180A	CE 2200μ 16V			
C407,408	OB09393A	CC 68P 50V J			
	OB05652A	CM 4700P 50V J			

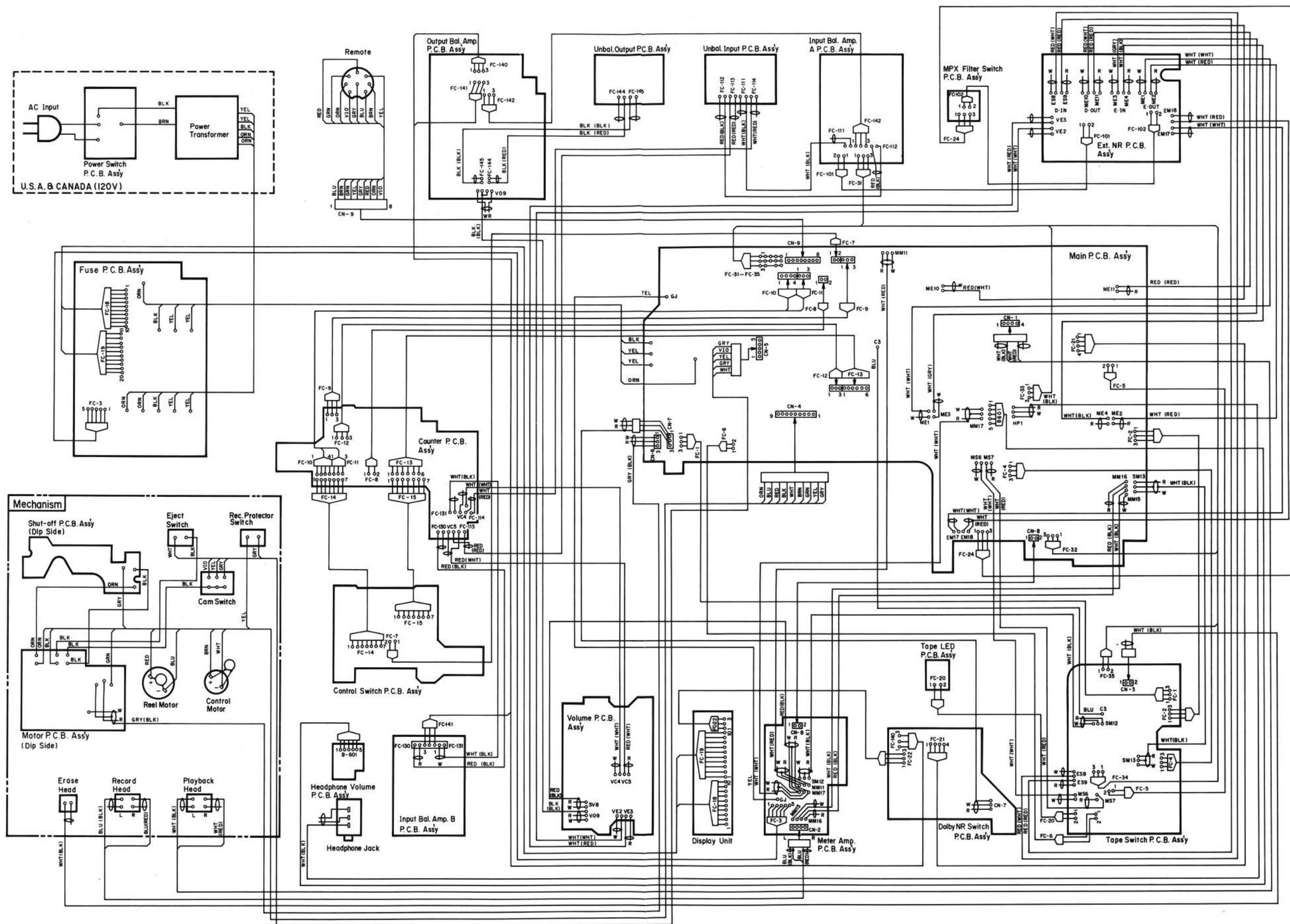

Fig. 2

- Notes: 1. Noise Reduction System manufactured under license from Dolby Laboratories Licensing Corporation.
 2. The word "DOLBY" and the Double-D-symbol are trademarks of Dolby Laboratories Licensing Corporation.

Service Information

(608) 255-1538
430 State Street
Madison, WI 53703



Nakamichi

Model BX-100, BX-125, BX-150, BX-1, BX-2,
MR-2, RX-202/CR-7, CR-5, BX-300, MR-1

Serial No. from -

Subject How to Change Take-up/Supply Reel Hub Ass'y and
Reel Motor Ass'y from Pulley Type to Gear Type

No. OOD-SI-3117 (1/5)
Date 27 January 1989

1. Introduction

This Service Information is prepared to inform you of the way how to change the Take-up Reel Hub Ass'y, Supply Reel Hub Ass'y and Reel Motor Ass'y from current pulley type to gear type.

This change applies to the following models:

- o 2 Head Cassette Decks (See 2.1.)
BX-100, BX-125, BX-150, BX-1, BX-2, MR-2, RX-202
- o 3 Head Cassette Decks (See 2.2.)
CR-7, CR-5, BX-300, MR-1

2. Replacement Procedures

2.1. For 2 Head Cassette Decks

2.1.1. Parts Required

<u>Ref. No.</u>	<u>Current Part No.</u>	<u>New Part No.</u>	<u>New Description</u>	<u>Q'ty</u>
12 (14)	CA80003B	CA80725A	Take-up Reel Hub Ass'y	1
13 (15)	CA80004B	CA80726A	Supply Reel Hub Ass'y	1
41 (38)	OC80030A	OC82722A	Reel Motor Holder B	1
42 (39)	CA80008B	CA80728A	Reel Motor Ass'y	1
L07 (L08)	OE03049A	OE03049A	Washer 1.8x3.2x0.5	2
L08 (L09)	OE03050A	OE03226A	Washer 2.1x4.5x0.1	2
	-	OC80613A	Reel Hub Spring	2
	-	OC80612A	Spring Holder	2

(): for RX-202 Only.

2.1.2. Replacement Procedures

Refer to Fig. 1. (Although Fig. 1 shows the exploded view of the BX-125's Mechanism Ass'y, parts to be replaced are common to all models.)

- (1) Remove the Top Cover, Bottom Cover and Cassette Case Cover Ass'y.
- (2) Remove the Mechanism Ass'y.
- (3) Remove the Cover Plate from the Mechanism Ass'y.
- (4) Change the Reel Motor Ass'y, Take-up Reel Hub Ass'y and Supply Reel Hub Ass'y from the current pulley type to gear type.
 - (a) Remove L07 (2 pcs.) and pull out the Take-up Reel Hub Ass'y (12) and Supply Reel Hub Ass'y (13).
 - (b) Remove L08 (2 pcs.) and the Back Tension Springs (40; 2 pcs.).
 - (c) Unsolder the signal wires (RED ⊕ and BLK ⊖) of the Reel Motor Ass'y (42).
 - (d) Loosen L06 (3 pcs.) and remove the Reel Motor Holder (41) from the Mechanism Ass'y.
 - (e) Loosen L18 (2 pcs.), remove the Reel Motor Ass'y (42), and replace with a new gear type Reel Motor Ass'y.
 - (f) Install a new Reel Motor Holder (41) on the Mechanism Ass'y.
Note: Make sure that the Cassette Hold Spring (31) is in place, as it falls easily.
 - (g) Solder the signal wires (RED ⊕ and BLK ⊖) to the new Reel Motor Ass'y (42).
 - (h) Install the Back Tension Springs (40; 2 pcs.).
 - (i) Install Reel Hub Springs (2 pcs.), Spring Holders (2 pcs.) and Washers 2.1x4.5x0.1 (2 pcs.) on the Reel Hub Shafts in that order.
Note: When installing the Spring Holder, insert its pin into the hole in the Mechanism Chassis (32).
 - (j) Install a new gear type Take-up Reel Hub Ass'y and Supply Reel Hub Ass'y, and then Washers 1.8x3.2x0.5 (2 pcs.).
Note: Check that there is a play in the Reel Hub Ass'y.
- (5) Install the Cover Plate on the Mechanism Ass'y.
- (6) Install the Mechanism Ass'y on the Cassette Deck.
- (7) Check for correct mechanical operations and make sure that the torque in Play mode is within 35 g-cm to 40 g-cm.
- (8) Install the Cover Plate, Cassette Case Cover Ass'y, Bottom Cover, and Top Cover.

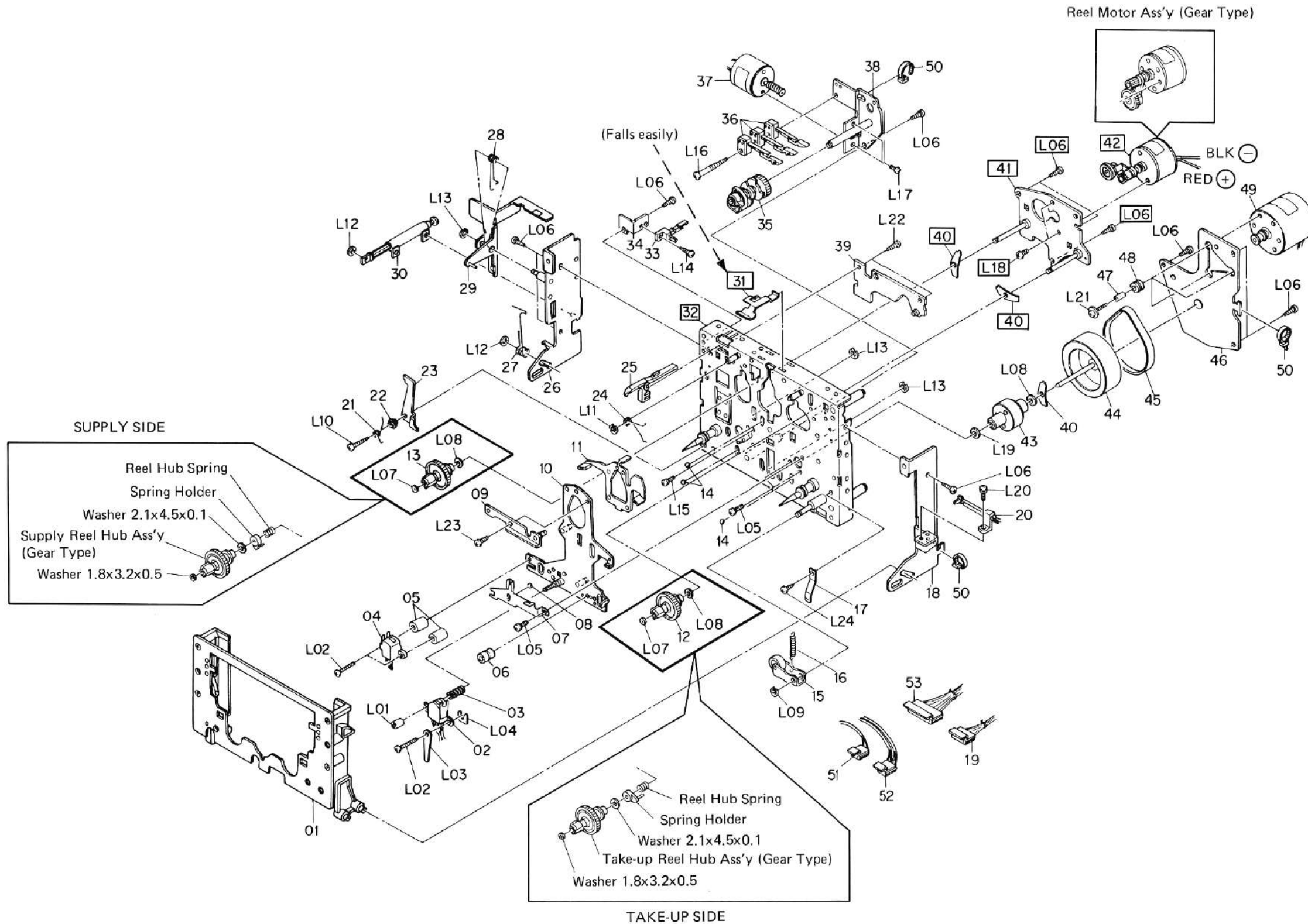

Fig. 1 2 Head Cassette Deck (In case of BX-125)

MEMO

Lined writing area with horizontal dotted lines.

MEMO

Lined writing area with horizontal dotted lines.

2.2. For 3 Head Cassette Decks

2.2.1. Parts Required

(1) For CR-7

<u>Ref. No.</u>	<u>Current Part No.</u>	<u>New Part No.</u>	<u>New Description</u>	<u>Q'ty</u>
21	CA80201A	CA80725A	*Take-up Reel Hub Ass'y	2
72	CA80205A	CA80730A	Reel Motor Ass'y	1
L10	OE03049A	OE03049A	Washer 1.8x3.2x0.5	2

*: Take-up Reel Hub Ass'y is used for both take-up side and supply side.

(2) For CR-5/BX-300/MR-1

<u>Part No.</u>	<u>Current Part No.</u>	<u>New Part No.</u>	<u>New Description</u>	<u>Q'ty</u>
CA80201A	CA80201A	CA80725A	Take-up Reel Hub Ass'y	1
CA80202A	CA80202A	CA80726A	Supply Reel Hub Ass'y	1
CA80205A	CA80205A	CA80730A	Reel Motor Ass'y	1
OE03049A	OE03049A	OE03049A	Washer 1.8x3.2x0.5	2

2. Replacement Procedures

Refer to Fig. 2. (Although Fig. 2 shows the exploded view of the CR-7's Mechanism Ass'y, parts to be replaced are common to all models.)

- (1) Remove the Top Cover, Bottom Cover and Cassette Case Cover Ass'y.
- (2) Remove the Mechanism Ass'y.
- (3) Remove the Cover Plate from the Mechanism Ass'y.
- (4) Change the Reel Motor Ass'y, Take-up Reel Hub Ass'y and Supply Reel Hub Ass'y from the current pulley type to gear type.
 - (a) Disengage the Back Tension Belt (13) from the Supply Reel Hub Ass'y (21).
 - (b) Remove L10 (2 pcs.), and pull out the Take-up Reel Hub Ass'y (21) and Supply Reel Hub Ass'y (21).
 - (c) On the take-up side, remove the Washer L08, Spring Holder (22) and Take-up Reel Hub Spring (51).
Note: Keep these take-up side parts as one set.
 - (d) On the supply side, remove the Washer L08, Spring Holder (22) and Supply Reel Hub Spring (23).
Note: Keep these supply side parts as one set. Distinguish this set from the take-up side one.
 - (e) Loosen the Screw (43), unhook L15, and remove the Azimuth Alignment Plate (45). (For CR-7 only)
 - (f) Unsolder two signal wires (RED ⊕ and BLK ⊖) of the Reel Motor Ass'y (72).
 - (g) Unsolder two signal wires (BLK from the Eject Switch and BLK from the Cam Switch) of the D.D. Motor P.C.B. Ass'y.
 - (h) Remove the D.D. Motor Ass'y (73) as follows:
Note: Use a smaller philips screwdriver.
 - 1) Open the Cassette Case Ass'y (24) and loosen the upper side Screws L01-1 (2 pcs.)
 - 2) Push the Head Mount Plate (28) to slide it, and loosen the lower side Screws L01-1 (2 pcs.)
Note: The Screw L01 on the bottom left is under the Lock Lever (16). So, when loosening it, pay attention so as not to bend the Lock Lever (16).
 - 3) Remove the D.D. Motor Ass'y (73) gently from the Mechanism Chassis (62) so as not to give damages to the capstan shafts.
 - (i) Loosen L01-2 (2 pcs.) and nut L32, and remove the Reel Motor Holder (70).

Note: Remember the original positions of the nut L30 on the Brake Ass'y (66) and the Cassette Hold Spring (63), as they come off when removing the Reel Motor Holder (70).

- (j) Loosen L31 (2 pcs.), remove the current Reel Motor Ass'y (72), and replace with a new gear type Reel Motor Ass'y.
- (k) Install the new gear type Reel Motor Ass'y on the Reel Motor Holder (70), and the Reel Motor Holder (70) on the Mechanism Chassis (62).

Note: Before installing the Reel Motor Holder (70), put the nut L30 and Cassette Hold Spring (63) in place. Then slide the Brake Ass'y (66) with your finger to check for smooth movement. If not, re-check the positions of the nut L30 and Cassette Hold Spring (63).

- (l) Install the D.D. Motor Ass'y (73) by fastening L01-1 (4 pcs.).

Note: Carefully install the D.D. Motor Ass'y (73) as the D.D. Motor P.C.B. Ass'y can be damaged.

- (m) Solder two signal wires (RED ⊕ and BLK ⊖) to the new Reel Motor Ass'y and two signal wires (BLK) to the D.D. Motor P.C.B. Ass'y.

- (n) Install the Take-up Reel Hub Ass'y as follows:

- 1) Use the take-up side parts removed in (c). Install the Take-up Reel Hub Spring (51), Spring Holder (22) and Washer L08 on the Take-up Reel Hub Shaft in that order.

Note: When installing the Spring Holder (22), insert its pin into the hole in the Mechanism Chassis (62).

- 2) Install a new gear type Take-up Reel Hub Ass'y and a Washer 1.8x3.2x0.5.

Note: Check that there is a play in the Take-up Reel Hub Ass'y.

- (o) Install the Supply Reel Hub Ass'y as follows:

- 1) Use the supply side parts removed in (d). Install the Supply Reel Hub Spring (23), Spring Holder (22) and Washer L08 on the Supply Reel Hub Shaft in that order.

Note: When installing the Spring Holder (22), insert its pin into the hole in the Mechanism Chassis (62).

- 2) Install a new gear type Supply Reel Hub Ass'y and a Washer 1.8x3.2x0.5.

Note: Check that there is a play in the Supply Reel Hub Ass'y.

- (p) Engage the Back Tension Belt (13) with the Supply Reel Hub Ass'y (21).

- (q) Install the Azimuth Alignment Plate (45). (CR-7 only)

- (5) Install the Mechanism Ass'y on the Cassette Deck.

- (6) Check for correct mechanical operations and make sure that the torque in Play mode is within 35 g-cm to 40 g-cm.

- (7) Install the Cover Plate, Cassette Case Cover Ass'y, Bottom Cover, and Top Cover.

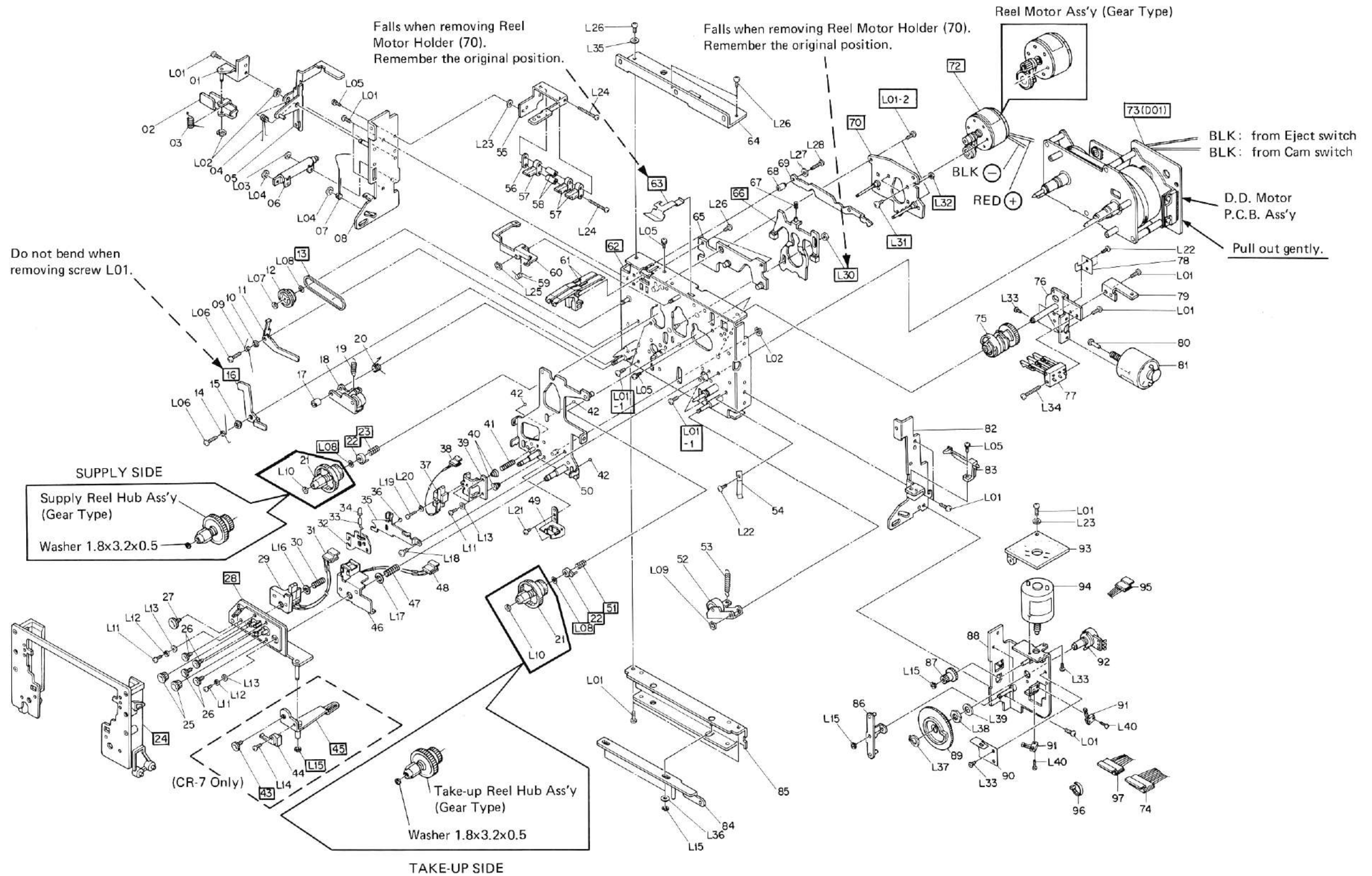

Fig. 2 3 Head Cassette Deck (In case of CR-7)

MEMO

Lined area for writing on the left page.

MEMO

Lined area for writing on the right page.

Service Manual

Nakamichi MR-1

Nakamichi Corporation/Tokyo Office
Nakamichi America Corporation
Nakamichi Canada
Nakamichi Australia
Nakamichi GmbH

Shinjuku Daiichi Seimei Bldg., 2-7-1 Nishishinjuku, Shinjuku-ku, Tokyo 163 Phone: (03) 3342-4461 Telex: 2324721 (NAKAM J)
19701 South Vermont Ave., Torrance, CA 90502 Phone: (213) 538-8150
276 South West, Marine Drive, Vancouver, B.C. V5X 2R4 Phone: (604) 324-7535
Level 2, 61A Dunning Ave., Rosebery, N.S.W. 2018 Phone: (02) 313-7071/7090
Praunheimer Landstraße 32, 6000 Frankfurt Main 90 Phone: (069) 768-2021 (Office), 2025 (Service)