

AKAI SERVICE MANUAL

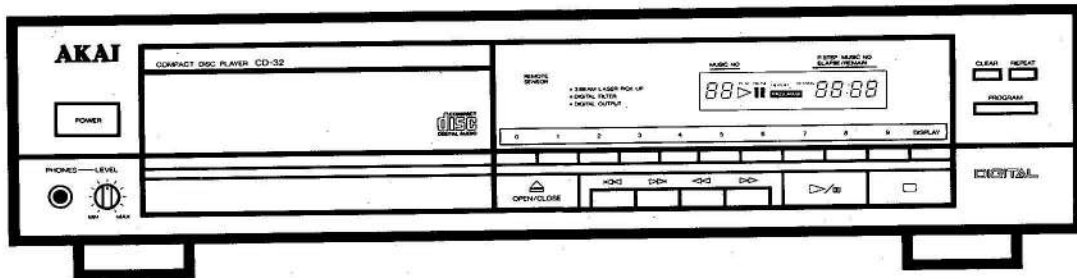

COMPACT DISC PLAYER

MODEL CD-32



SPECIFICATIONS

System.....	Compact disc player
Pick-up system	3 beam Laser pick up
Sampling frequency	44.1 kHz
Digital filter	16 bit, 2 times over sampling
D/A converter	16 bit linear
Error correction system	Cross Interleave Reed Solomon
Number of channels	2 channels (Stereo)
Frequency response	5 Hz to 20 kHz ± 0.5 dB
Dynamic range	90 dB or more
S/N.....	98 dB or more
Total harmonic distortion.....	0.005% or less
Wow & Flutter	Less than measurable limits
Analogue output level	2 V (0 dB)
Digital output level/Impedance	0.5 Vp-p/75 ohms
Headphone output level/Impedance	28 mW/32 ohms
Power requirements	120 V, 60 Hz for USA and Canada 220 V, 50 Hz for Europe except UK 240 V, 50 Hz for UK and Australia 110 V—120 V/220 V—240 V, 50 Hz/60 Hz convertible for other countries
Dimensions	425 (W) \times 98 (H) \times 330 (D) mm (16.7 \times 3.9 \times 13.0 inches)
Weight.....	4.3 kg (9.5 lbs)

* For improvement purposes, specifications and design are subject to change without notice.

★ SAFETY INSTRUCTIONS

PRECAUTIONS DURING SERVICING

1. Parts identified by the (*) symbol parts are critical for safety. Replace only with parts number specified.
2. In addition to safety, other parts and assemblies are specified for conformance with such regulations as those applying to spurious radiation.
These must also be replaced only with specified replacements.
Examples: RF converters, tuner units, antenna selector switches, RF cables, noise blocking capacitors, noise blocking filters, etc.
3. Use specified internal wiring. Note especially:
 - 1) Wires covered with PVC tubing
 - 2) Double insulated wires
 - 3) High voltage leads
4. Use specified insulating materials for hazardous live parts. Note especially:
 - 1) Insulation Tape
 - 2) PVC tubing
 - 3) Spacers (Insulating Barriers)
 - 4) Insulation sheets for transistors
 - 5) Plastic screws for fixing microswitch (especially in turntable)
5. When replacing AC primary side components (transformers, power cords, noise blocking capacitors, etc.), wrap ends of wires securely about the terminals before soldering.

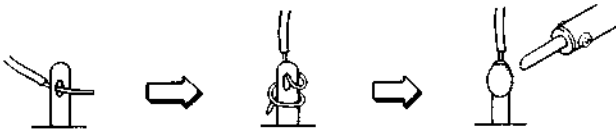

6. Observe that wires do not contact heat producing parts (heatsinks, oxide metal film resistors, fusible resistors, etc.).

7. Check that replaced wires do not contact sharp edged or pointed parts.
8. Also check areas surrounding repaired locations.
9. Use care that foreign objects (screws, solder droplets, etc.) do not remain inside the set.

SAFETY CHECK AFTER SERVICING

Confirm the specified insulation resistance between power cord plug prongs and externally exposed parts of the set is greater than 10 M ohms. but for equipment with external antenna terminals (tuner, receiver, etc.) and is intended for [C] or [A], specified insulation resistance should be headphone jacks line-in-out jacks etc. more than 2.2 M ohms (ground terminals, microphone jacks).

★ INFORMATION

SYMBOLS FOR PRIMARY DESTINATION

Alphabet indicates the destination of the units as listed below.

Symbols	Principal Destinations
[A]	USA
[B]	UK
[C]	Canada
[E]	Europe (except UK)
[J]	Japan
[S]	Australia
[V]	W. Germany only
[U]	Universal Area
[Y*]	Custom version

VOLTAGE CONVERSION ([U] Model only)

Before connecting the power cord. SET the VOLTAGE SELECTOR located on the rear panel with a screwdriver so that the correct voltage is indicated.

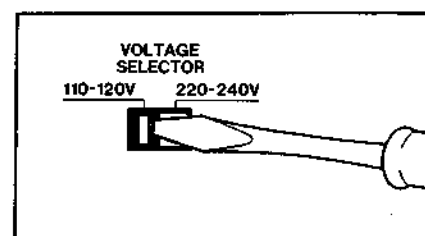

PRECAUTIONS IN REPAIRING

When repairing or adjusting the unit, please note the following points.

1. Do not put excessive pressure on the mechanical part (operation part), including the pick-up block, as extremely high mechanical precision is required in these parts.
2. When the base is removed for repair or adjustment, make sure that there are no metal objects in the narrow gap between the P.C board or the mecha parts and the base.
3. The Micro-Computer and the CD signal processing ICs can be damaged by static electricity or leakage from a soldering iron during repairing. While soldering, please take the precautions against leakage as in the illustration below.

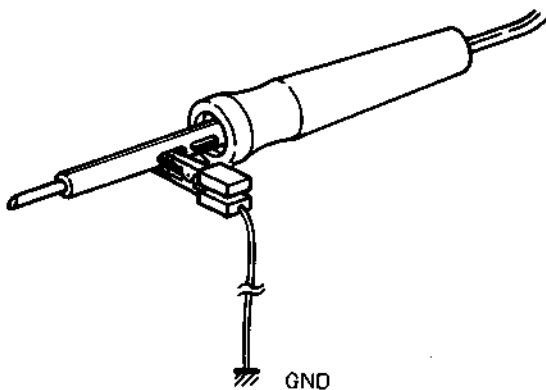

4. Do not loosen any screws in the pick-up block. When handling the Pick-up block, please refer to the points to NOTE when replacing the pick-up block.
5. Keep safety from hazardous invisible Laser Radiation, DO NOT watch the Laser Beam (objective Lens) Directly.
6. Models for the same countries, Laser Warning Labels are affixed on the unit and inside of the unit, as shown below. Read it carefully for your safety, when repairing or adjusting the unit.

[DENMARK and UK]

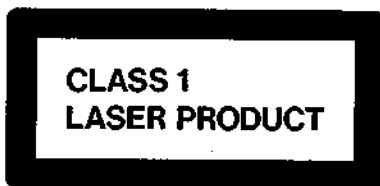

A Label affixed on the Rear Panel of the unit

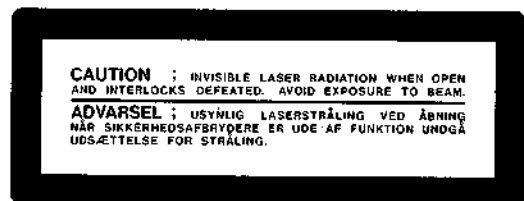

A Label affixed on the Disc clamber inside of the unit

[USA]



A Label Printed on the Rear Panel of the unit

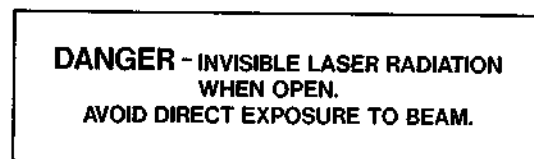

A Label affixed on the Disc clamber inside of the unit

I. CONTROLS

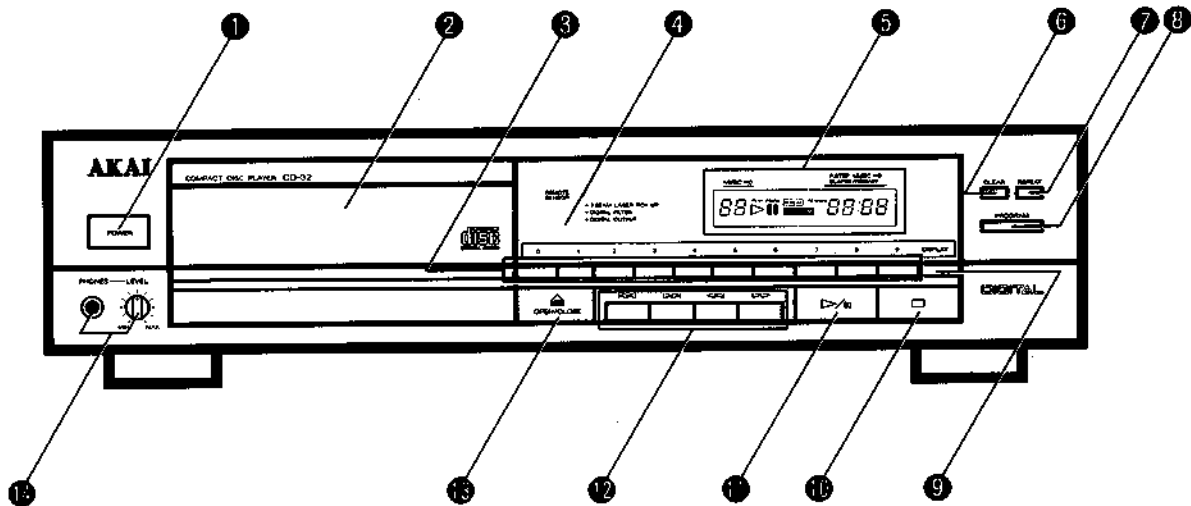

- 1 POWER Button**
To turn the power on and off.
- 2 Disc Drawer**
Load a compact disc here.
- 3 Numeric Buttons (0 to 9)**
For direct search of the track you wish to playback and for programming for random program playback.
- 4 REMOTE SENSOR Window**
For reception of the remote control signal.
Keep away from strong light and direct sunlight as this will interfere with the remote control function.
- 5 FL (Fluorescent) Display**
Tells you what the Akai CD player is doing.
- 6 CLEAR Button**
To cancel all the programmed tracks for random program playback.
- 7 REPEAT Button**
For repeat playback of all the tracks or the random program.
- 8 PROGRAM Button**
For random program playback.
- 9 DISPLAY Button**
To switch between the remaining playback time display and the elapsed playback time display.
- 10 STOP Button**
To stop playback.
- 11 ▷ / ⏸ PLAY/PAUSE Button**
To start and stop playback temporarily.
- 12 ◀◀ / ▶▶ and ◀◀ / ▶▶ Search Buttons**
◀◀ / ▶▶ Buttons
For manual search during playback.
◀◀ / ▶▶ Buttons
To skip tracks during playback.
- 13 △ OPEN/CLOSE Button**
To open and close the disc drawer.
- 13 PHONES Jack and LEVEL Control**
For headphone listening.

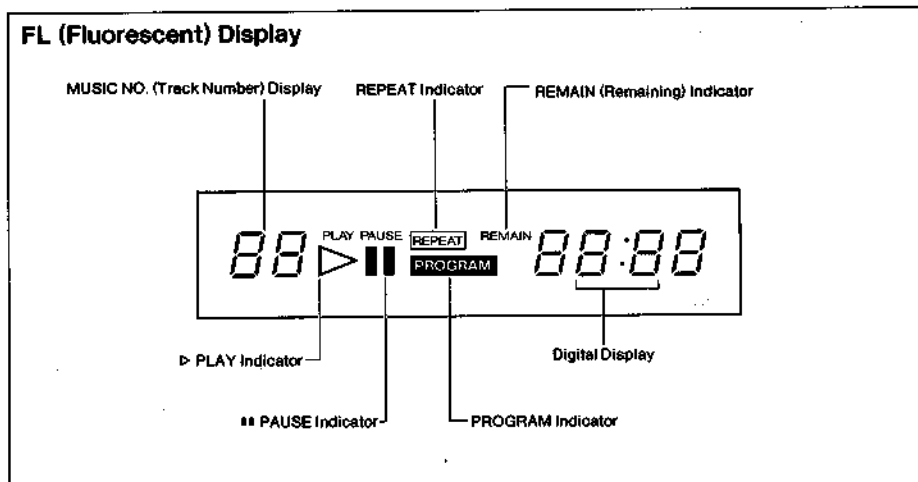

II. DISASSEMBLY

In case of trouble, etc. necessitating dismantling, please dismantle in the order shown in the photographs. Reassemble in reverse order.

1. Removal of Upper Cover

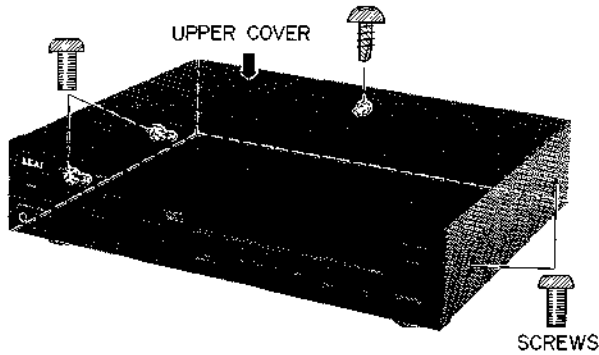

2. Removal of Front Panel

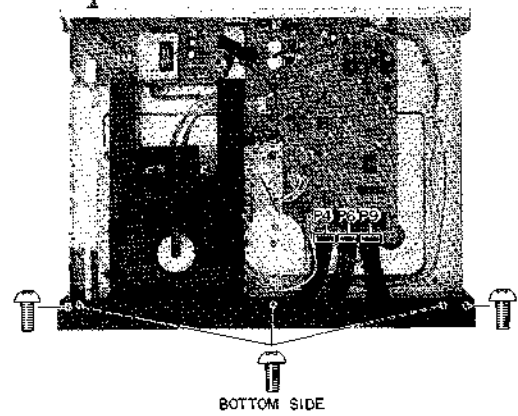

* Before remove the FRONT PANEL, disconnect the connectors P4, P6 and P9. (While disconnecting the wire from the connector, press upper side of connector.)

III. PRINCIPAL PARTS LOCATION

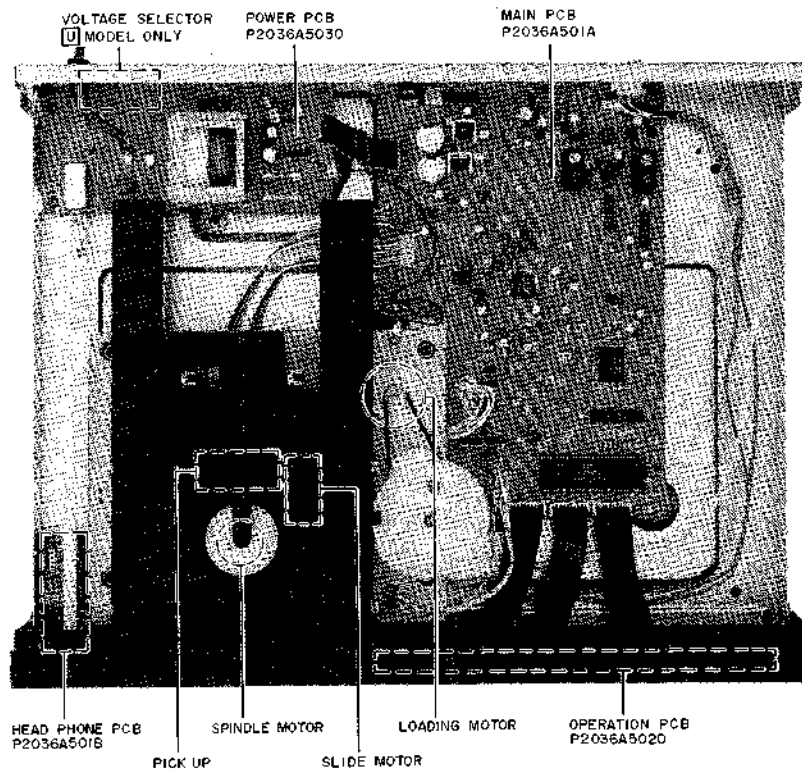

IV. REMOVAL OF THE MAIN PCB AND DISC CLAMPER

NOTE:

Keep your safety from hazardous invisible Laser Radiation. Make sure that the Power switch is OFF, when removing the disc clasper.

4-1. REMOVAL OF THE MAIN PCB

- 1) Disconnect the connectors P1, P2, P3, P4, P6 and P9. (P4, P6 and P9, refer to II. DISASSEMBLY)
- 2) Remove the MAIN PCB fixing screws (A), (B), (C), (D) and (E), also resolder (F) and (G), then remove the MAIN PCB. (Refer to Fig. 4-1)

4-2. REMOVAL OF THE DISC CLAMPER

- 1) Turn the LOADING CAM GEAR to counterclockwise, then open the DISC TRAY.
 - 2) Remove the SPRING from between MECHA CHASSIS and DISC CLAMPER.
 - 3) Move the DISC CLAMPER (→ direction), then remove the DISC CLAMPER.
- * Reassemble in reverse order. (Refer to Fig. 4-1)

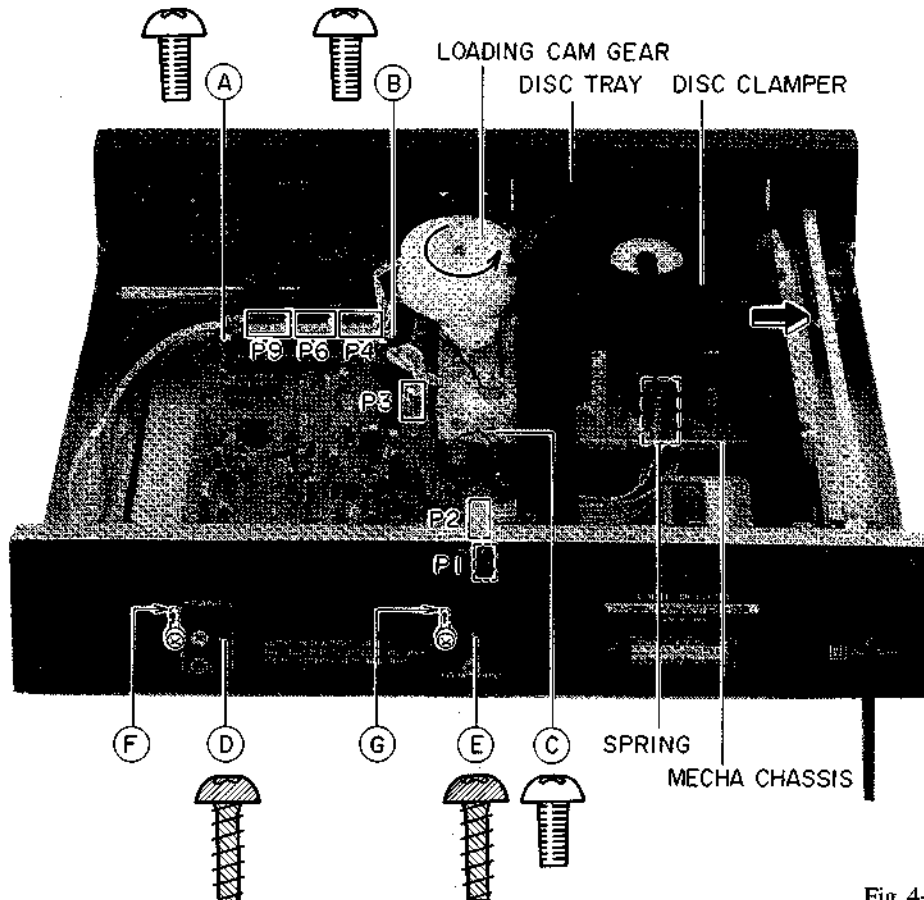

Fig. 4-1

V. REPLACEMENT OF PICK-UP BLOCK

5-1. PRECAUTION, WHEN REPLACING THE PICK-UP BLOCK

*Note: When connecting or disconnecting the connectors, make sure that the P.C. Board (on the Pick-Up Block) has to be shorted circuit as shown in Fig. 5-1. Do not turn the electricity "ON" while it remains shorted-circuited.

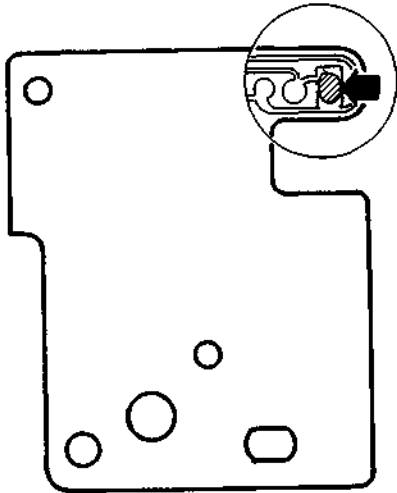

Fig. 5-1

5-2. REMOVAL OF THE MECHANICAL BLOCK

- 1) Turn off the power.
- 2) Disconnect the connectors P1, P2, P3 and P5 on the MAIN PCB.
- 3) Remove screws (A), (B), (C) and (D). (Refer to Fig. 5-2)
- 4) Remove the MECHANICAL BLOCK from the main chassis.

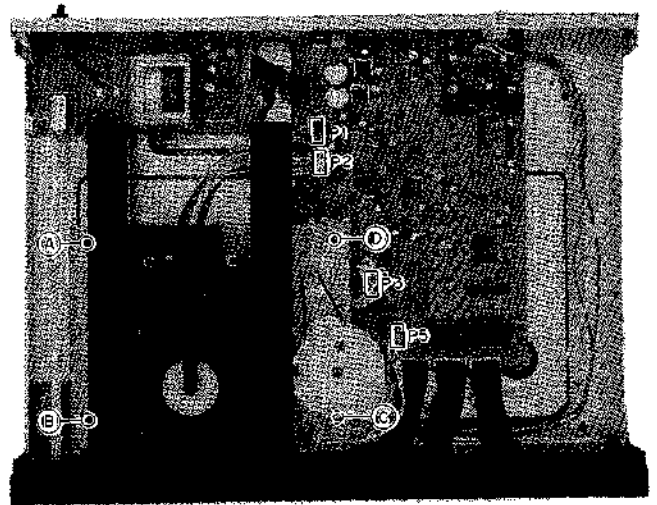

Fig. 5-2

5-3. REMOVAL OF THE PICK-UP BLOCK

- 1) Open the disc tray and disconnect the connectors on the pick-up block. (Refer to Fig. 5-3)
- 2) Push the (A) part in a ← direction, at the same time, push the (B) part (shaft) in a ← direction, then remove the PICK-UP BLOCK. (Refer to Fig. 5-3)
- 3) Reassemble in reverse order. (Refer to Fig. 5-3)

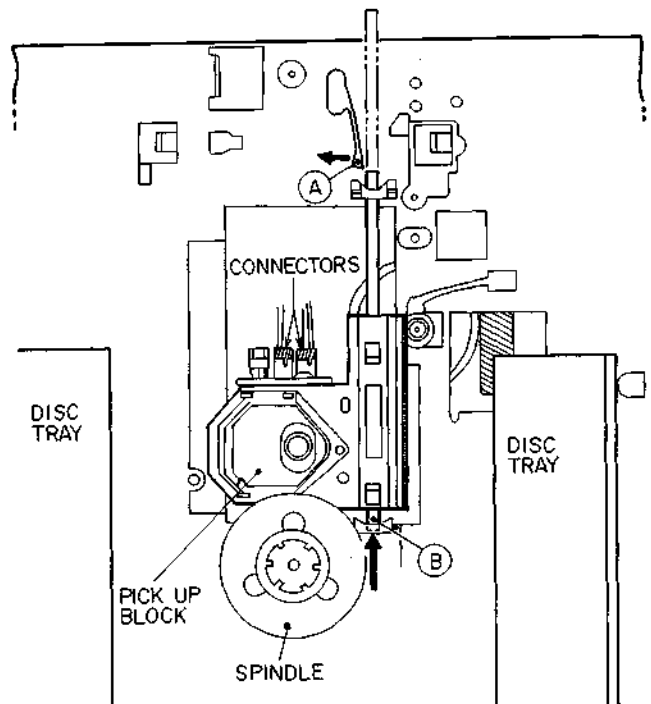

Fig. 5-3

VI. REPLACEMENT OF MOTORS

6-1. Replacement of the LOADING MOTOR

- 1) Remove the loading belt from loading motor.
- 2) Extend motor holders ©, at the same time, push the loading motor from pulley side, then remove the loading motor. (Fig. 6-1)
- 3) Reassemble, just push in the loading motor.

6-2. Replacement of the SLIDE MOTOR

- 1) Turn the motor lock lever Ⓑ clockwise.
- 2) Pull out the slide motor. (Fig. 6-1)
- 3) Reassemble in reverse order.

6-3. Replacement of the SPINDLE MOTOR

- 1) Turn the gear hold lever Ⓐ counterclockwise. (Fig. 6-1)
- 2) Pull out the slide gear.
- 3) Move the pick-up block to opposite from the spindle motor.
- 4) Turn the turntable so that the screw peep through the turntable. (Refer to Fig. 6-2)
- 5) Use small screwdriver. Remove the screws through into the turntable, then remove the SPINDLE MOTOR.

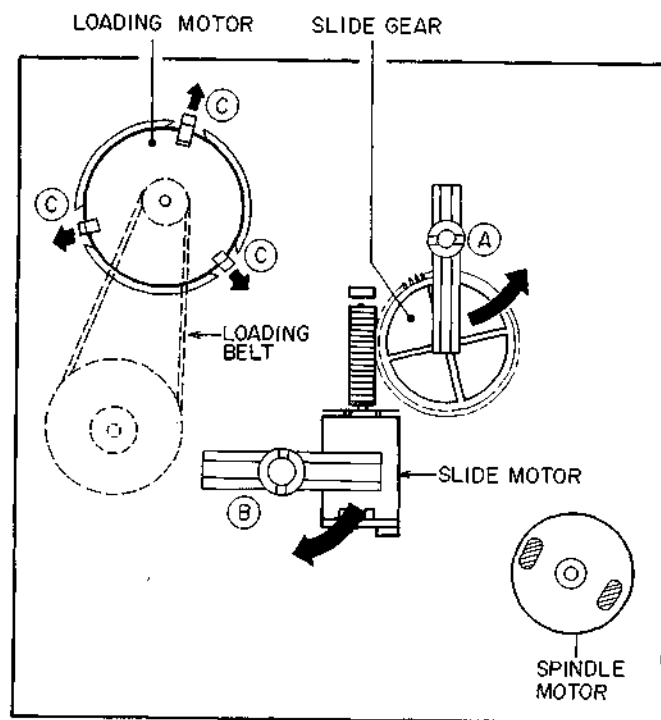

Fig. 6-1

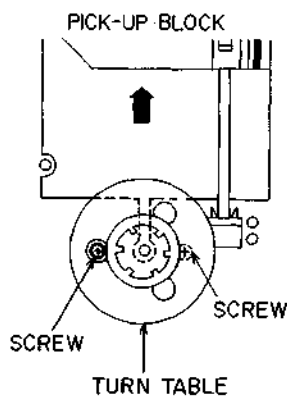

Fig. 6-2

AKAI

MODEL CD-32

SCHEMATIC DIAGRAM AND PC BOARDS

BA6019 REVERSIBLE MOTOR DRIVER

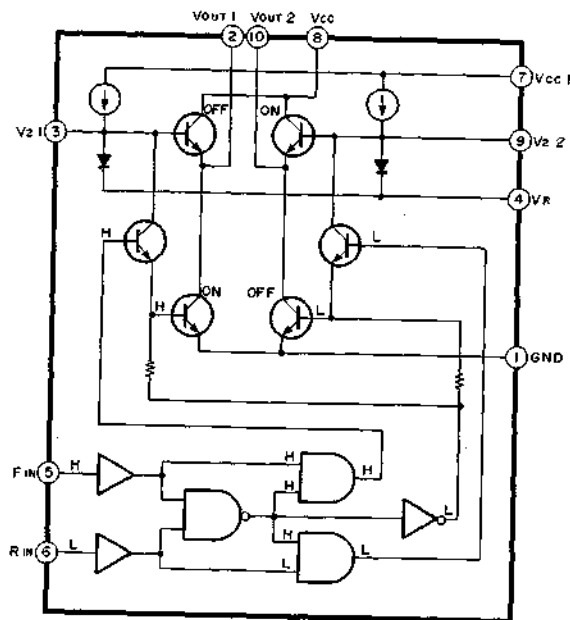

FIN	RIN	Vout1	Vout2
1	1	L	L
0	1	L	H
1	0	H	L
0	0	L	L

1 = More than 2.0V
0 = Less than 0.7V

CXA1081 RF AMPLIFIER

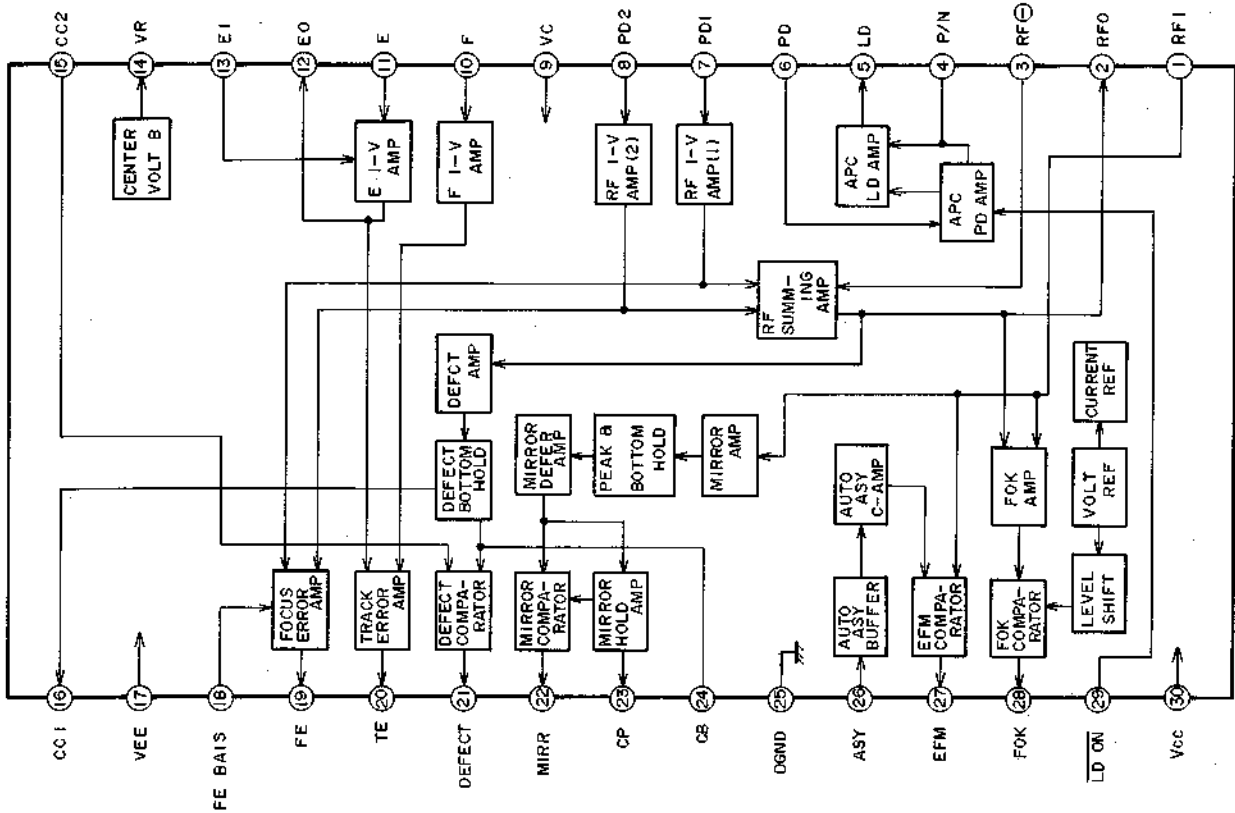

CXA1081

PIN NO.	SYMBOL	I/O	FUNCTION
1	RF1	I	RF SIGNAL FROM SUMMING AMP
2	RF0	O	RF SIGNAL OUT (EYE PATTERN CHECK POINT)
3	RFΘ	I	FEED BACK TO SUMMING AMP
4	P/N	-	NC
5	LD	O	AUTO POWER CONTROL OUT (TO LASER DIODE)
6	PD	I	AUTO POWER CONTROL IN (FROM PILOT DIODE)
7	PD1	I	A+C SIGNAL RF I-V AMP IN
8	PD2	I	B+D SIGNAL RF I-V AMP IN
9	VC	-	GND
10	F	I	TRACKING DIODE SIGNAL RF I-V AMP IN (F)
11	E	I	TRACKING DIODE SIGNAL RF I-V AMP IN (E)
12	E0	O	RF I-V AMP (E) OUT
13	E1	I	FEED BACK TO RF I-V AMP (E)
14	VR	-	NC
15	CC2	I	DEFECT BOTTOM HOLD IN
16	CC1	O	DEFECT BOTTOM HOLD OUT
17	VEE	-	-B
18	F·EBLAS	I	FOCUS OFF-SET VOLTAGE IN
19	FE	O	FOCUS ERROR OUT
20	TE	O	TRACKING ERROR OUT
21	DEFECT	O	DEFECT COMPALATOR OUT
22	MIRR	O	MIRROR COMPALATOR OUT
23	CP	I	CONNECT MIRROR HOLD CONDENSER
24	CB	I	CONNECT BOTTOM HOLD CONDENSER
25	DGND	-	GND
26	ASY	I	AUTO ASYMMETRY SIGNAL IN
27	EFM	O	EFM COMPALATOR OUT
28	FOK	O	FOCUS OK COMPALATOR OUT
29	LDON	I	LASER DIODE ON/OFF CONTROL IN
30	VCC	-	+B

CXA1082A SERVO SIGNAL PROCESOR

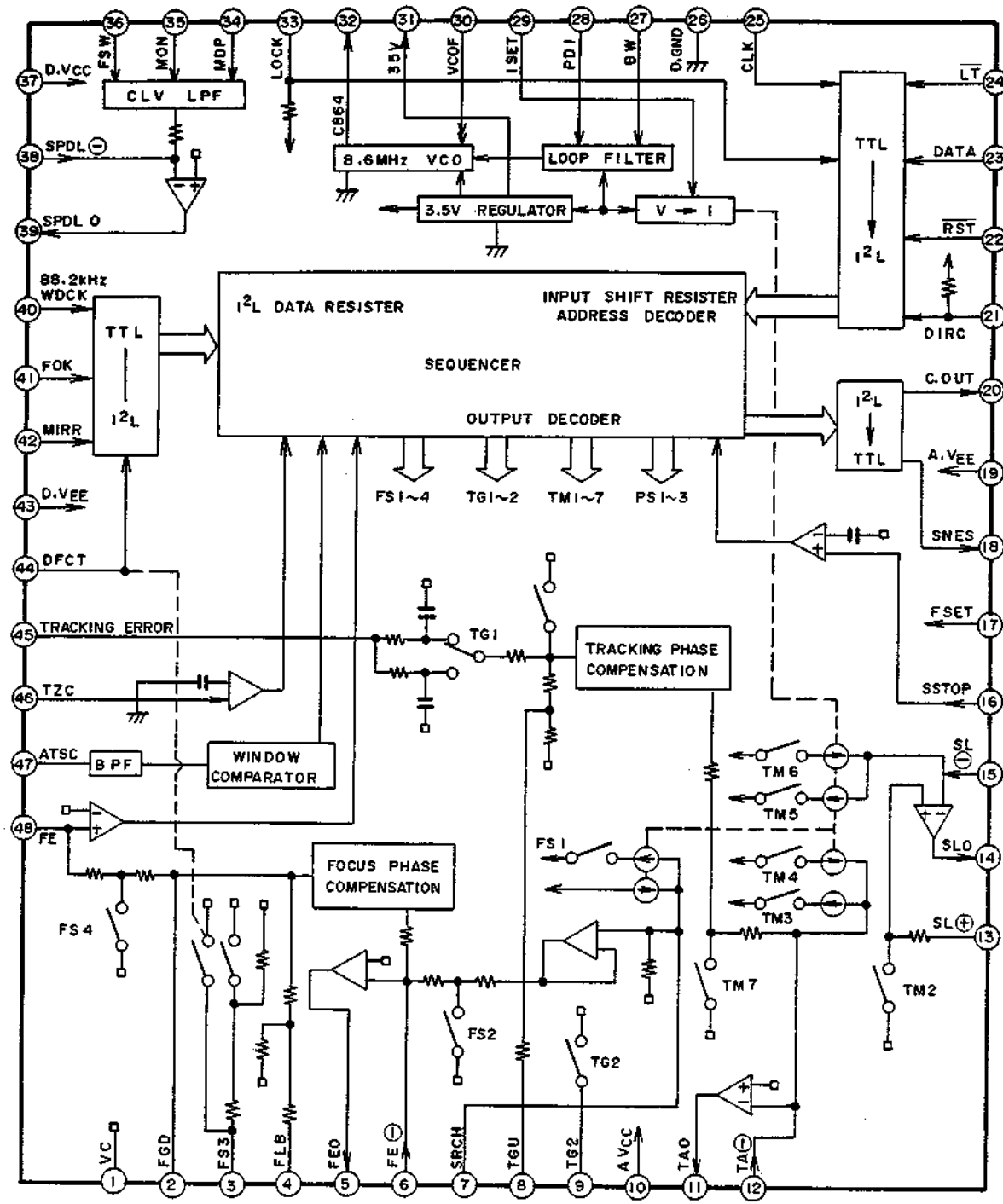

CXA 1082A

PIN NO.	SYMBOL	I/O	DESCRIPTION
1	VC	—	GND (0V)
2	FGD	—	Connect condenser for Focus servo gain control.
3	FS3	—	Focus servo gain select.
4	FLB	—	Connect condenser for Focus servo correction.
5	FE0	O	Focus drive output.
6	FE ⊖	I	FOCUS AMP. Inverting input.
7	SRCH	—	Connect condenser for Focus search wave.
8	TGU	—	Connect condenser for Tracking gain select.
9	TG2	—	Connect condenser for Tracking gain select.

PIN NO.	SYMBOL	I/O	DESCRIPTION
10	A.VCC	—	+5V
11	TA0	O	Tracking drive output.
12	TA ⊖	I	Tracking AMP. Inverting input.
13	SL ⊕	I	Slide motor non-inverting input
14	SLO	O	Slide motor drive output.
15	SL ⊖	I	Slide AMP. inverting input.
16	SSTOP	I	Not use (Holed "H" level).
17	FSET	I	Focus, Tracking compensation and CLV. LPF set up.
18	SENS	O	FZC. AS. TZC. SSTOP and $\overline{\text{BUSY}}$ output.
19	A. VEE	—	-5V.
20	C.OUT	O	Track count signal output.
21	DIRC	—	Not used
22	RST	I	RESET Input.
23	DATA	I	Data signal input from CPU.
24	LT	I	Lutch signal input from CPU.
25	CLK	I	Clock signal input from CPU.
26	D.GND	—	GND (0V).
27	BW	I	Connect condenser for Loop filter.
28	PDI	I	PDO signal from IC3 CXD1135Q (Pin 11).
29	ISET	I	Focus search, Track jump and slide kick current input.
30	VCOF	I	Connect register for VCO frequency.
31	3.5V	O	+3.5V REG. output.
32	C864	O	8.64 MHz VCO output.
33	LOCK	I	LOCK signal from IC3 CXD1135Q (Pin 7)
34	MDP	I	MDP signal from IC3 CXD1135Q (Pin 3)
35	MON	I	MON signal from IC3 CXD1135Q (Pin 2)
36	FSW	I	Connect condenser for CLV servo error signal LPF.
37	DVcc	—	+5V
38	SPDL ⊖	I	Spindle drive AMP. inverting input.
39	SPDLO	I	Spindle drive output.
40	WDCK	I	Auto sequence clock signal input (88.2 kHz)
41	FOK	I	Focus OK signal input.
42	MIRR	I	MIRR signal input.
43	DVEE	—	-5V
44	DFCT	I	Defect signal input "H" active.
45	TE	I	Tracking error signal input.
46	TZC	I	Tracking zero cross comparator input.
47	ATSC	I	ATSC detect window comparator input.
48	FE	I	Focus error signal input.

CXD1135Q DIGITAL SIGNAL PROCESOR

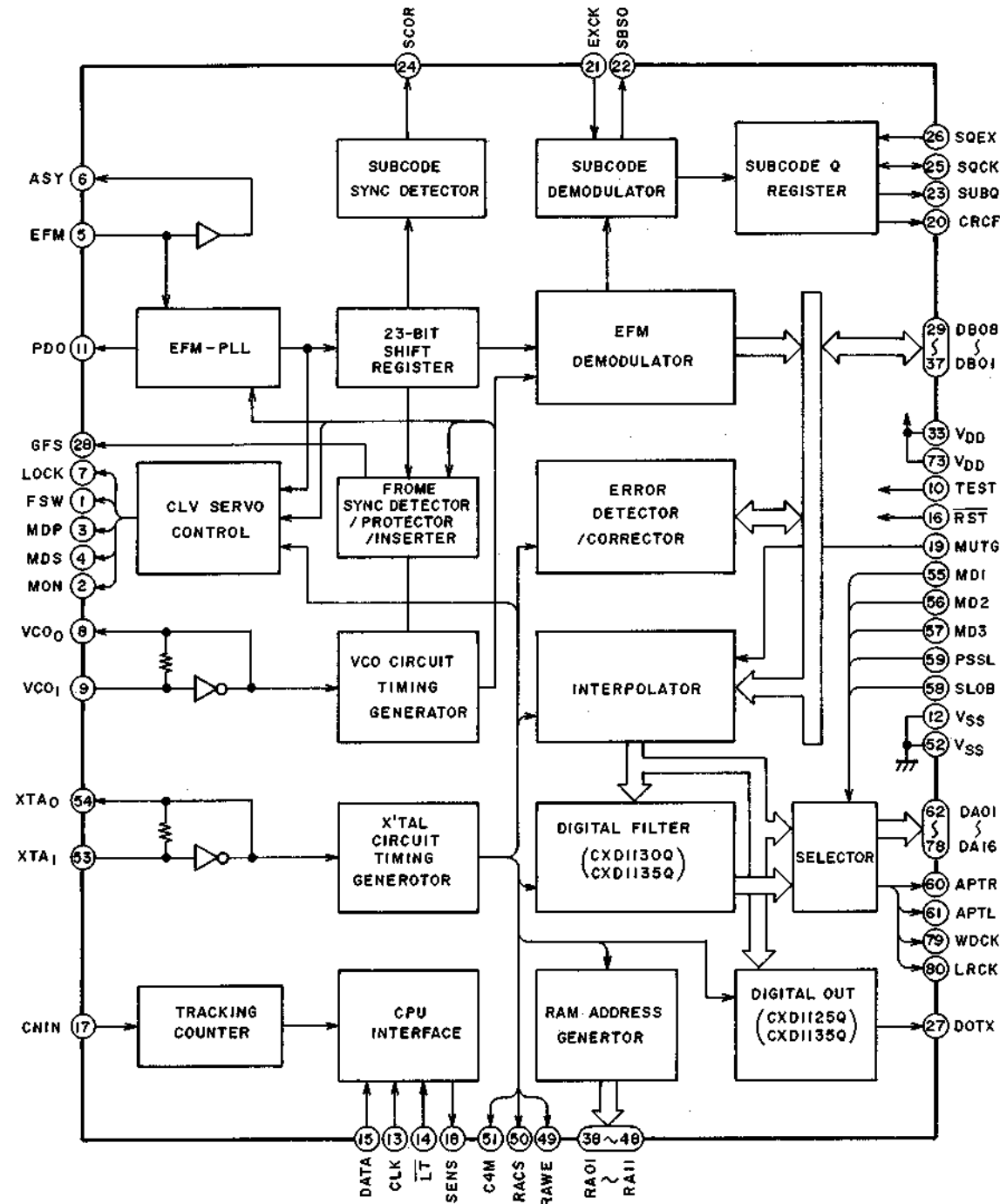

CXD1135Q

No.	Symbol	I/O	Description
1	FSW	O	Spindle motor filter switching control
2	MON	O	Spindle motor ON/OFF control
3	MPD	O	Spindle motor speed and phase control
4	MDS	O	Spindle motor speed control
5	EFM	I	EFM signal input
6	ASY	O	EFM signal slice level control
7	LOCK	O	Slide motor over reach guard signal output
8	VCOO	O	VCO output f=8.6436 MHz
9	VCOI	I	VCO input
10	TEST	I	OV (GND)
11	PDO	O	Phase comp.output
12	VSS	—	GND (OV)
13	CLK	I	Clock signal from CPU
14	LT	I	Lutch signal from CPU
15	DATA	I	Serial data from CPU
16	RST	I	RESET input "L" reset
17	CNIN	I	Tracking pulse input (5V)
18	SENS	O	Output of CPU interface
19	MUTG	I	Mute control signal input
20	CRCF	O	CRC check output of the subcode Q "L" detect error
21	EXCK	I	NOT USE
22	SBSO	O	NOT USE
23	SUBQ	O	Subcode Q output
24	SCOR	O	Subcode sync detection output
25	SQCK	I/O	Clock signal for subcode Q
26	SQEX	I	Select input of CQCK (+5V)
27	DOTX	O	Digital output
28	GFS	O	"H" frame sync lock "L" frame sync unlock
29	DB08	I/O	Data 8 (MSB) Data Bus line for the EXT.RAM (LC3517AS-15)
30	DB07	I/O	Data 7 Data bus line for the EXT.RAM (LC3517AS-15)
31	DB06	I/O	Data 6 Data Bus line for the EXT.RAM (LC3517AS-15)
32	DB05	I/O	Data 5 Data Bus line for the EXT.RAM (LC3517AS-15)
33	VDD	—	+5V
34	DB04	I/O	Data 4 Data Bus line for the EXT.RAM (LC3517AS-15)
35	DB03	I/O	Data 3 Data Bus line for the EXT.RAM (LC3517AS-15)
36	DB02	I/O	Data 2 Data Bus line for the EXT.RAM (LC3517AS-15)
37	DB01	I/O	Data 1 (LSB) Data Bus line for the EXT.RAM (LC3517AS-15)
38	RA01	O	ADDR01 (LSB) Address signal output for the EXT. RAM (LC3517AS-15)
39	RA02	O	ADDR02 Address signal output for the EXT. RAM (LC3517AS-15)
40	RA03	O	ADDR03 Address signal output for the EXT. RAM (LC3517AS-15)

No.	Symbol	I/O	Description
41	RA04	O	ADDR04 Address signal output for the EXT. RAM (LC3517AS-15)
42	RA05	O	ADDR05 Address signal output for the EXT. RAM (LC3517AS-15)
43	RA06	O	ADDR06 Address signal output for the EXT. RAM (LC3517AS-15)
44	RA07	O	ADDR07 Address signal output for the EXT. RAM (LC3517AS-15)
45	RA08	O	ADDR08 Address signal output for the EXT. RAM (LC3517AS-15)
46	RA09	O	ADDR09 Address signal output for the EXT. RAM (LC3517AS-15)
47	RA10	O	ADDR10 Address signal output for the EXT. RAM (LC3517AS-15)
48	RA11	O	ADDR11 (MSB) Address signal output for the EXT. RAM (LC3517AS-15)
49	RAWE	O	Write enable signal output "L" active
50	RACS	O	Chip select signal output "L" active
51	C4M	O	1/4X'tal OSC.output (f=4.2336MHz)
52	Vss	—	GND(0V)
53	XTAI	I	X'tal OSC. input (f=16.9344MHz)
54	XTAO	O	X'tal OSC.output (f=16.9344MHz)
55	MD1	I	Mode select input 1 0V (GND)
56	MD2	I	Mode select input 2 0V (GND)
57	MD3	I	Mode select input 3 0V (GND)
58	SLOB	I	0V (GND)
59	PSSL	I	0V (GND)
60	APTR	O	Aperture correction signal output "H" R-channel
61	APTL	O	Aperture correction signal output "H" L-channel
62	C1F1	O	NOT USE
63	C1F2	O	TP-C1F2
64	C2F1	O	NOT USE
65	C2F2	O	NOT USE
66	C2FL	O	TP-CSFL
67	C2P0	O	NOT USE
68	RFCK	O	NOT USE
69	WFCK	O	TP-WFCK
70	PLCK	O	NOT USE
71	UGFS	O	NOT USE
72	GTOP	O	NOT USE
73	VDD	—	+5V
74	RA0V	O	NOT USE
75	4CLR	O	NOT USE
76	C210	O	C210 INV.C210 (Pin 77) f=2.1168MHz
77	C210	O	NOT USE
78	DATA	O	Data output
79	WDCK	O	Word clock output 88.2kHz strobe
80	LRCK	O	NOT USE (L-ch, R-ch clock output)

CXP5016-260S

PIN NO.	SYMBOL	I/O	FUNCTION
1	EMP	O	EMPHASIS CODE OUTPUT
2	SYNCP	—	GND
3	RMT	I	REMOTE CONTROL DATA INPUT
4	SOCK	I/O	SUB CODE Q CLOCK
5			
6			
7	SUBQ	I	SUB CODE Q SIGNAL INPUT
8	PD0	O	KEY STROBE SIGNAL OUTPUT
9	PD1	O	
10	PD2	O	
11	PD3	O	
12	PC0	I	KEY RETURN SIGNAL INPUT
13	PC1	I	
14	PC2	I	
15	PC3	I	
16	PF0	I	
17	PF1	I	
18	LDIN	O	LOADING MOTOR FWD
19	LDOUT	O	LOADING MOTOR REV
20	CLSW	I	DISC TRAY CLOSE SWITCH
21	OPSW	I	DISC TRAY OPEN SWITCH
22	INSW	I	PICKUP IN SWITCH
23	LOK	I	LASER (FOCUS) OK SIGNAL INPUT
24	LSW	O	LASER ON/OFF CONTROL
25	GFS	I	FRAME SYNC LOCK SIGNAL INPUT
26	MUT	O	MUTE SIGNAL OUTPUT "H" MUTE ON
27	SENS	I	SENS SIGNAL INPUT FROM IC3
28	DATA	O	SERIAL DATA OUT
29	LT	O	LATCH SIGNAL OUT
30	CLK	O	CLOCK SIGNAL OUT
31	RST	I	RESET SIGNAL INPUT
32	GND	—	GND
33	S0	O	FLD SEGMENT DRIVER OUT
34	S1	O	
35	S2	O	
36	S3	O	
37	S4	O	
38	S5	O	
39	S6	O	
40	S7	O	
41 to 49			NOT USE
50	G7	O	FLD GRID DRIVER OUT
51	G6	O	
52	G5	O	
53	G4	O	
54	G3	O	
55	G2	O	
56	G1	O	
57	VP	I	FLD DRIVE POWER INPUT
58	—		NOT USE
59	SCOR	I	SUB CODE DETECTION SIGNAL INPUT
60	—		NOT USE
61	EXTAL	I	CLOCK INPUT
62	RST	I	RESET SIGNAL INPUT
63	SYNCR		NOT USE
64	VCC	I	+5V

LC3517AS-15 16KBIT RAM

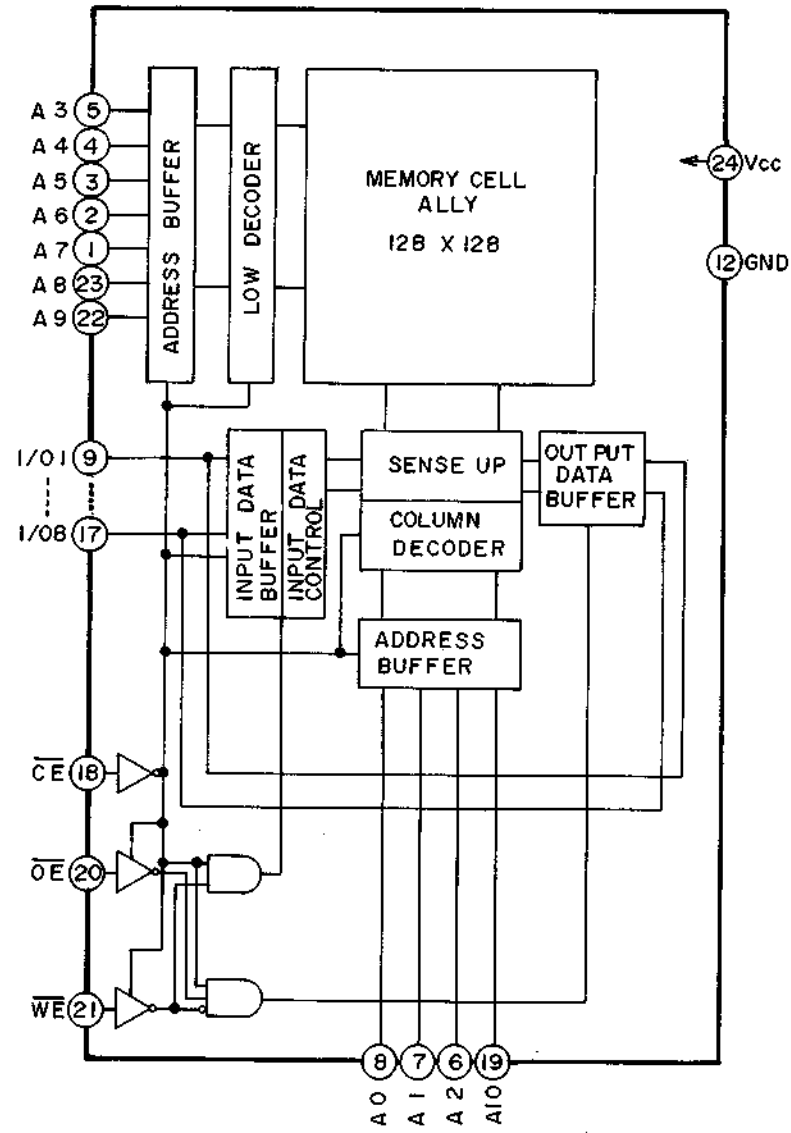

TRUTH TABLE

MODE	CE	OE	WE	I/O
READ CYCLE	L	L	H	DATA OUT
WRITE CYCLE	L	*	L	DATA IN
OUTPUT DISABLE	L	H	*	HIGH IMPEDANCE
INHIBIT	H	*	*	HIGH IMPEDANCE

PCM-56P 16BIT D/A CONVERTER

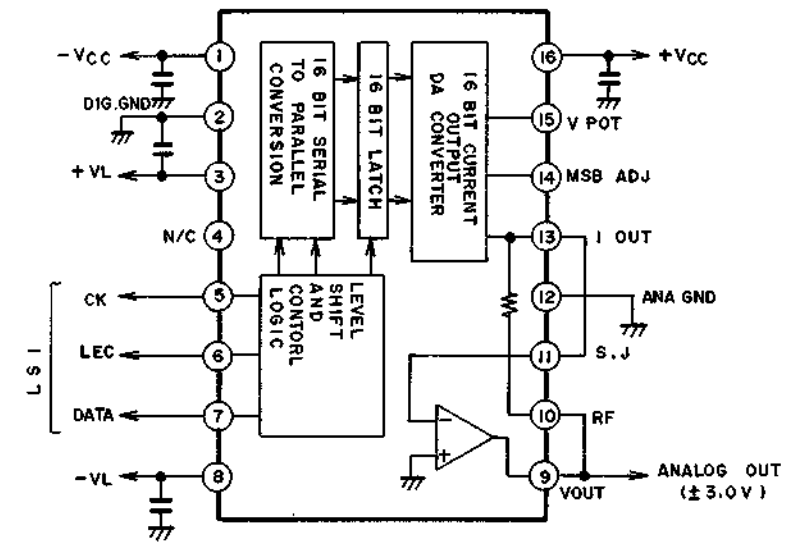

PIN NO.	FUNCTION	PIN NO.	FUNCTION
1	-Vcc	16	+Vcc
2	DIG. GND	15	VPOT
3	+VL	14	MSB ADJ
4	N/C	13	I OUT
5	CK	12	ANA GND
6	LEC	11	S.J
7	DATA	10	RF
8	-VL	9	Vout

TC4052BP MULTI PLEXER

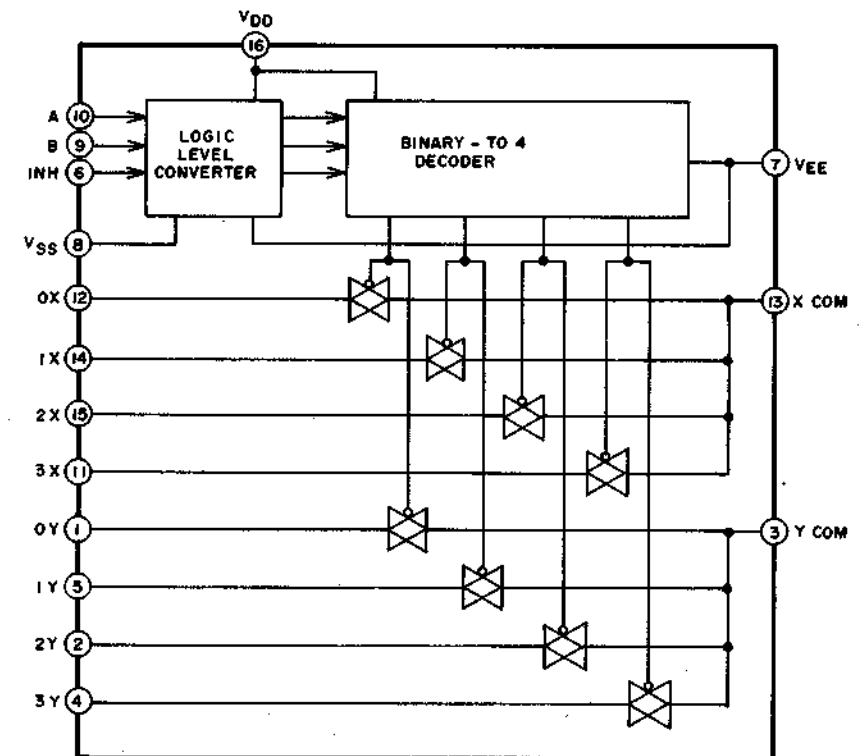

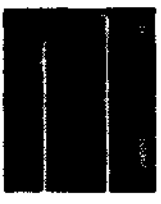
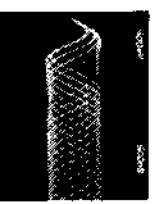
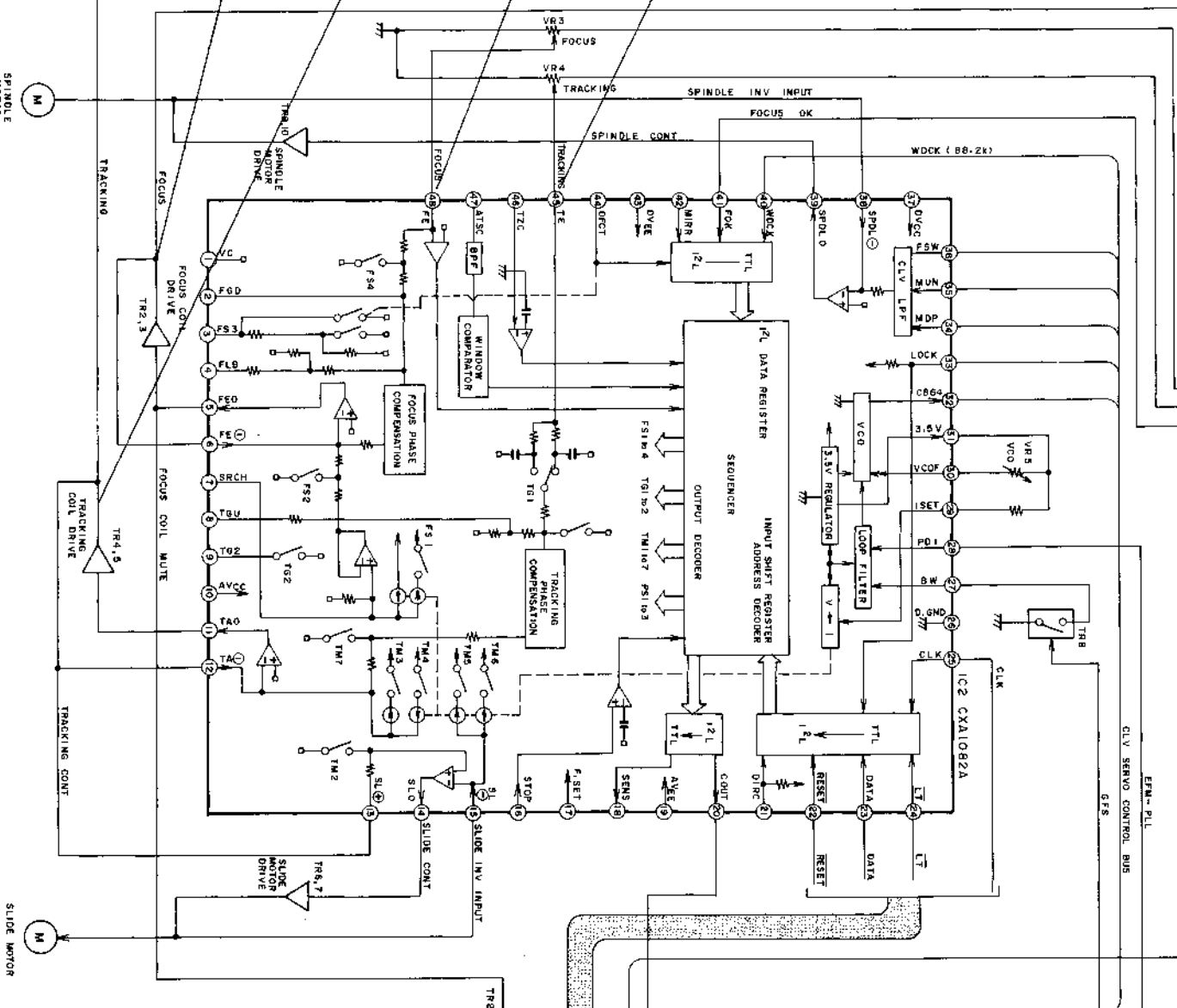
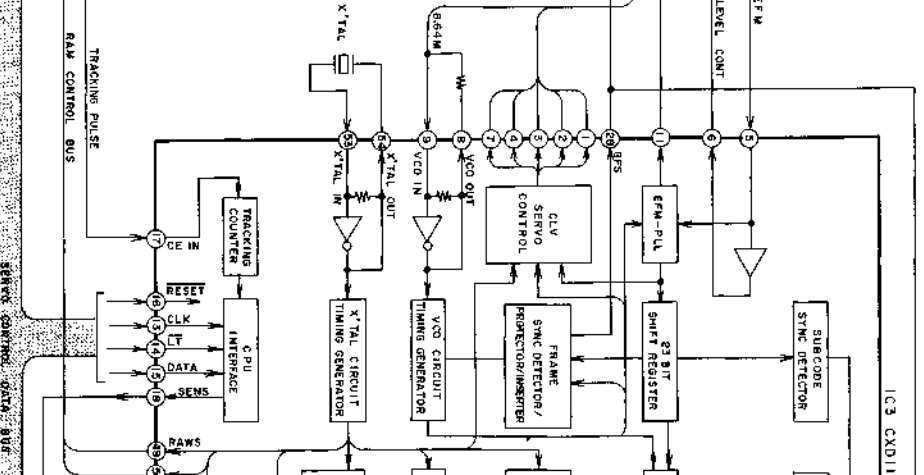
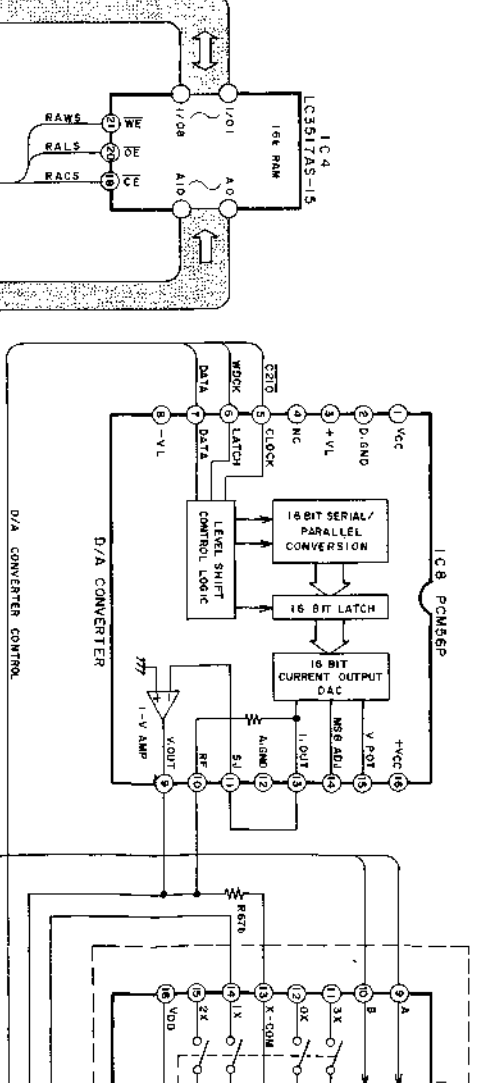
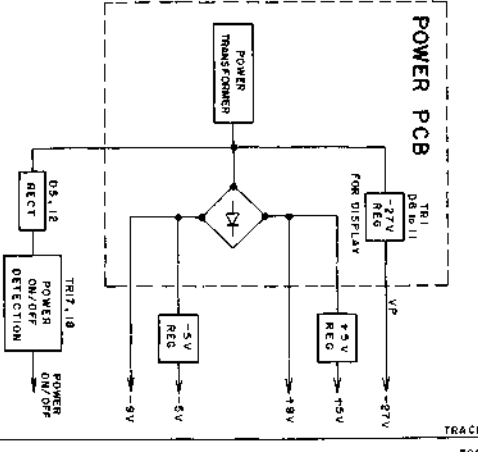
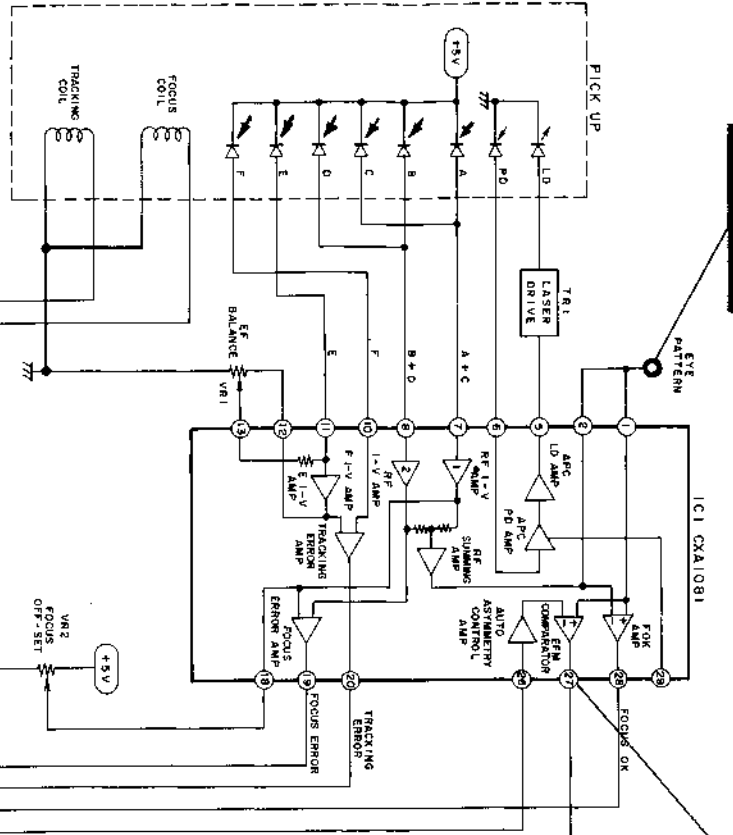
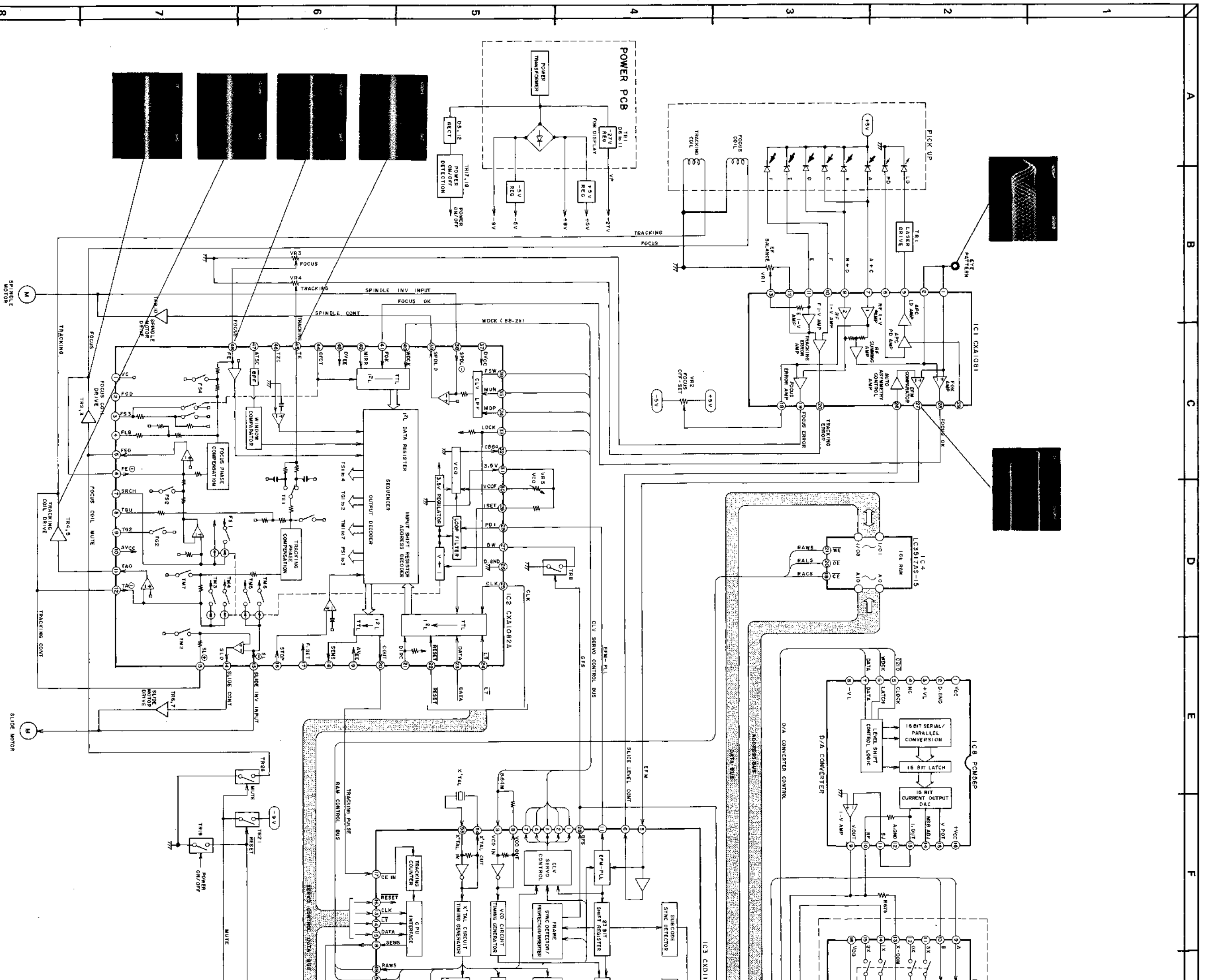

A B C D E F

8

7

6

5

4

3

2

1

SPINDLE MOTOR

SLIDE MOTOR

MUTE

RESET

POWER ON/OFF

TR19

TR18

TR17

TR16

TR15

TR14

TR13

TR12

TR11

TR10

TR9

TR8

TR7

TR6

TR5

TR4

TR3

TR2

TR1

TR0

TR-1

TR-2

TR-3

TR-4

TR-5

TR-6

TR-7

TR-8

TR-9

TR-10

TR-11

TR-12

TR-13

TR-14

TR-15

TR-16

TR-17

TR-18

TR-19

TR-20

TR-21

TR-22

TR-23

TR-24

TR-25

TR-26

TR-27

TR-28

TR-29

TR-30

TR-31

TR-32

TR-33

TR-34

TR-35

TR-36

TR-37

TR-38

TR-39

TR-40

TR-41

TR-42

TR-43

TR-44

TR-45

TR-46

TR-47

TR-48

TR-49

TR-50

TR-51

TR-52

TR-53

TR-54

TR-55

TR-56

TR-57

TR-58

TR-59

TR-60

TR-61

TR-62

TR-63

TR-64

TR-65

TR-66

TR-67

TR-68

TR-69

TR-70

TR-71

TR-72

TR-73

TR-74

TR-75

TR-76

TR-77

TR-78

TR-79

TR-80

TR-81

TR-82

TR-83

TR-84

TR-85

TR-86

TR-87

TR-88

TR-89

TR-90

TR-91

TR-92

TR-93

TR-94

TR-95

TR-96

TR-97

TR-98

TR-99

TR-100

CD-32
BLOCK DIAGRAM
NO. 871208A

STEREO SIGNAL LINE IS INDICATED
L-CHANNEL ONLY

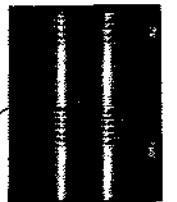
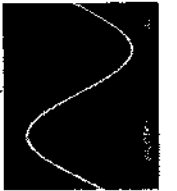
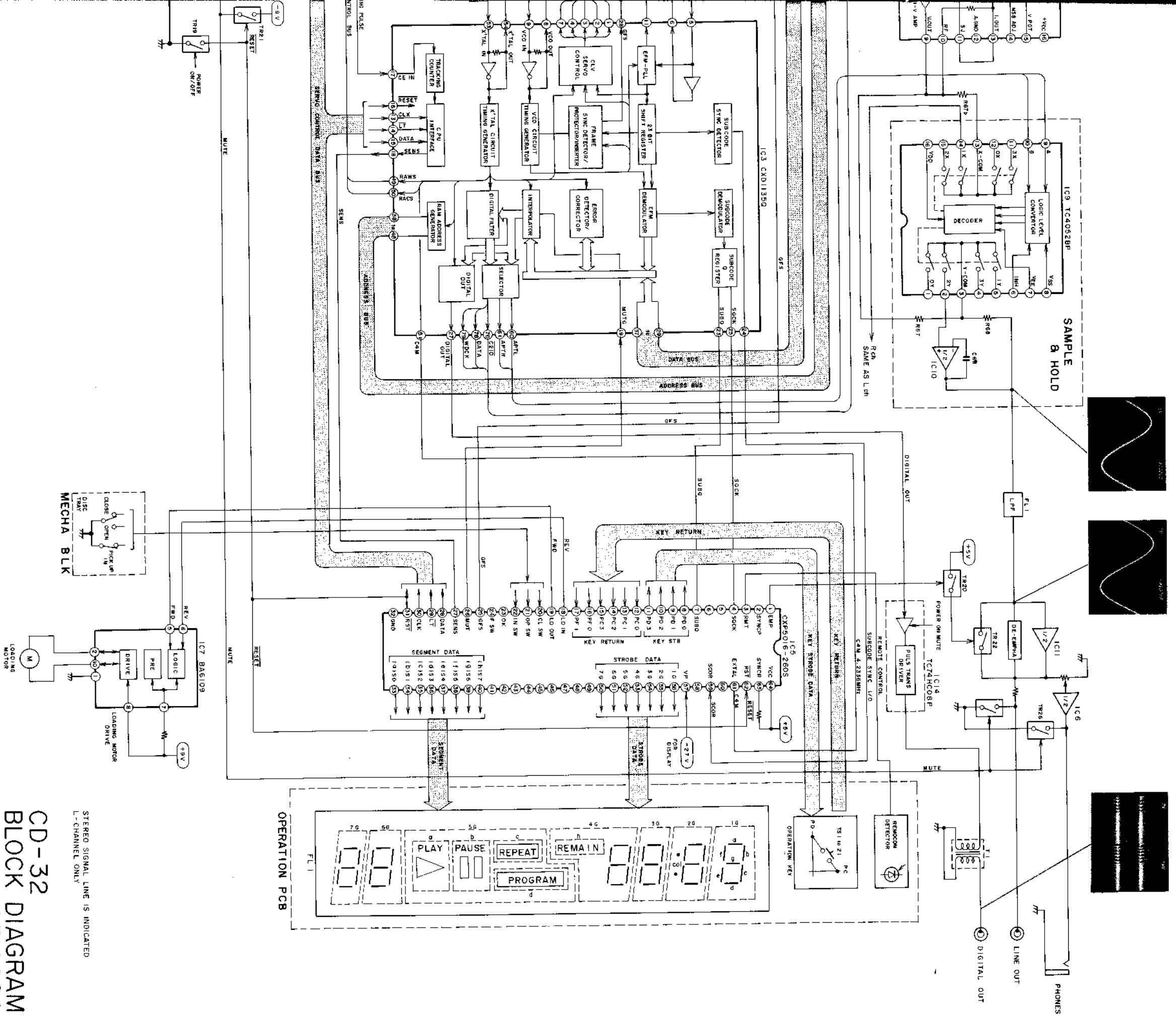

F G H I J K 7 8

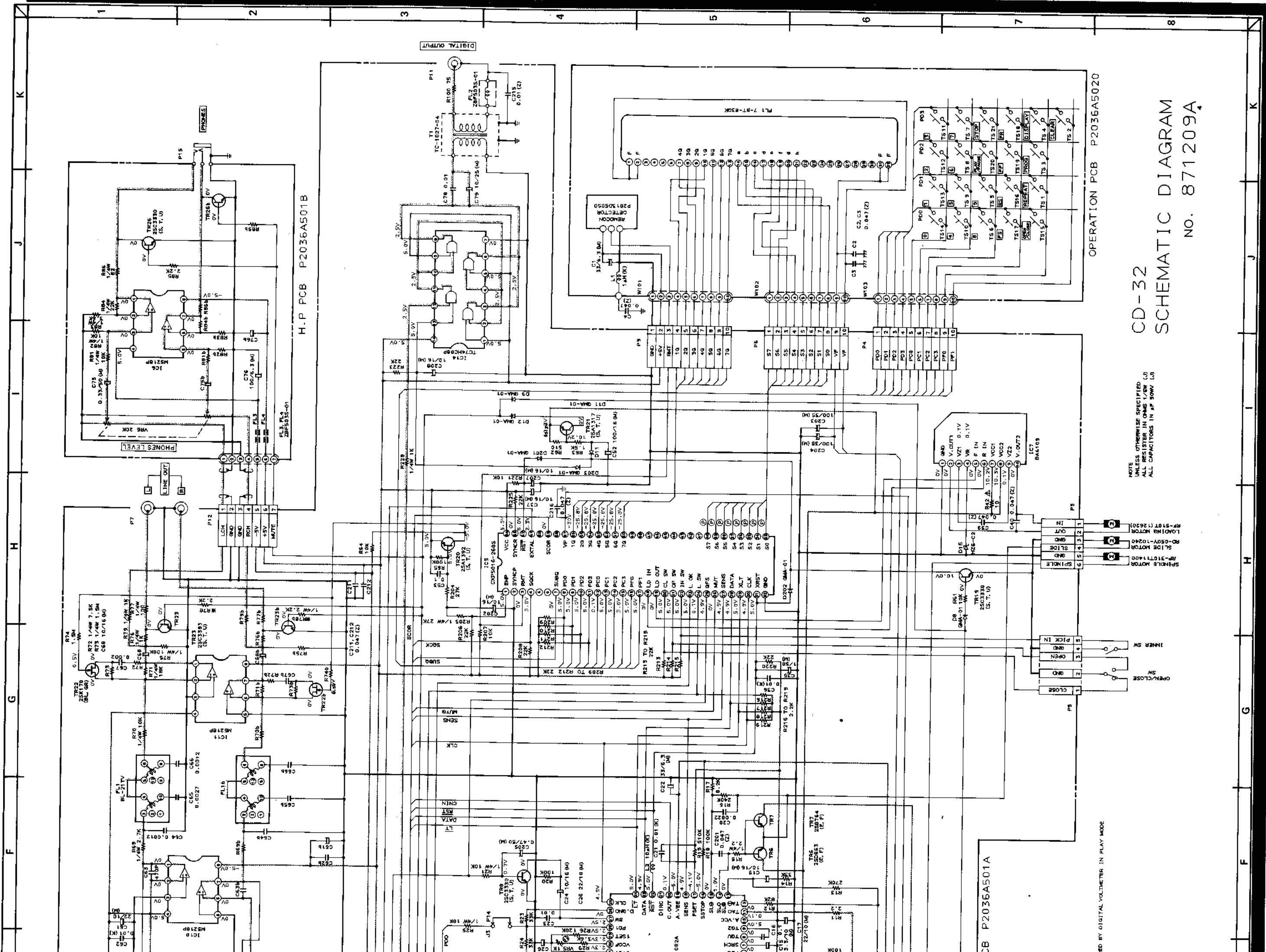

DESIGNED BY DIGITAL VOLTMETER IN PLAY MODE

NOTE
UNLESS OTHERWISE SPECIFIED
ALL RESISTORS IN OHMS 1/4W (J)
ALL CAPACITORS IN PF 50WV (J)

CD-32
SCHEMATIC DIAGRAM
NO. 871209A

OPERATION PCB P2036A5020

H.P. PCB P2036A501B

ICB P2036A501A

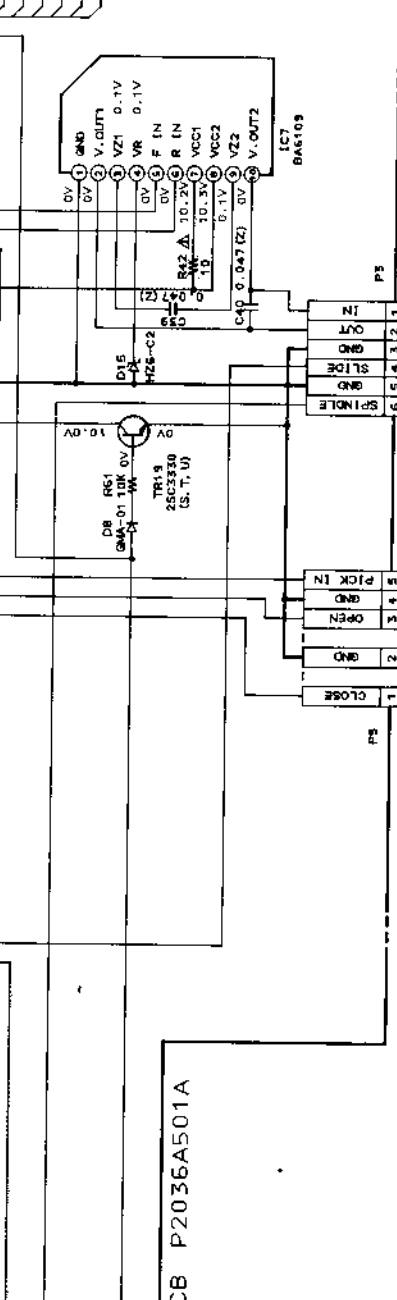
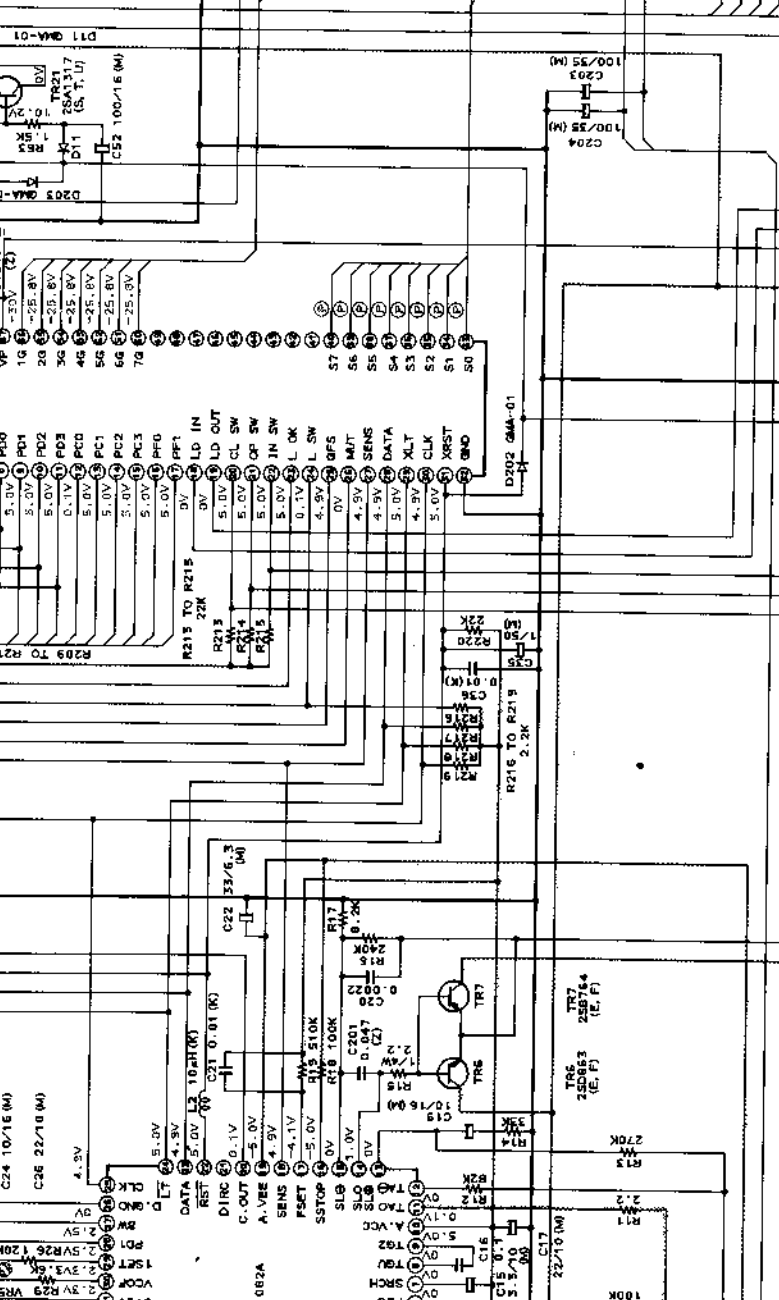
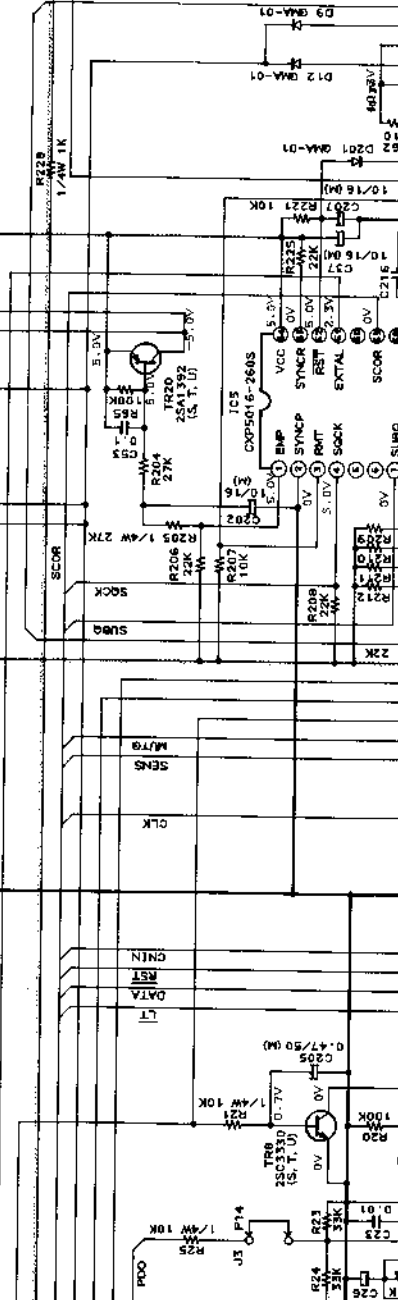
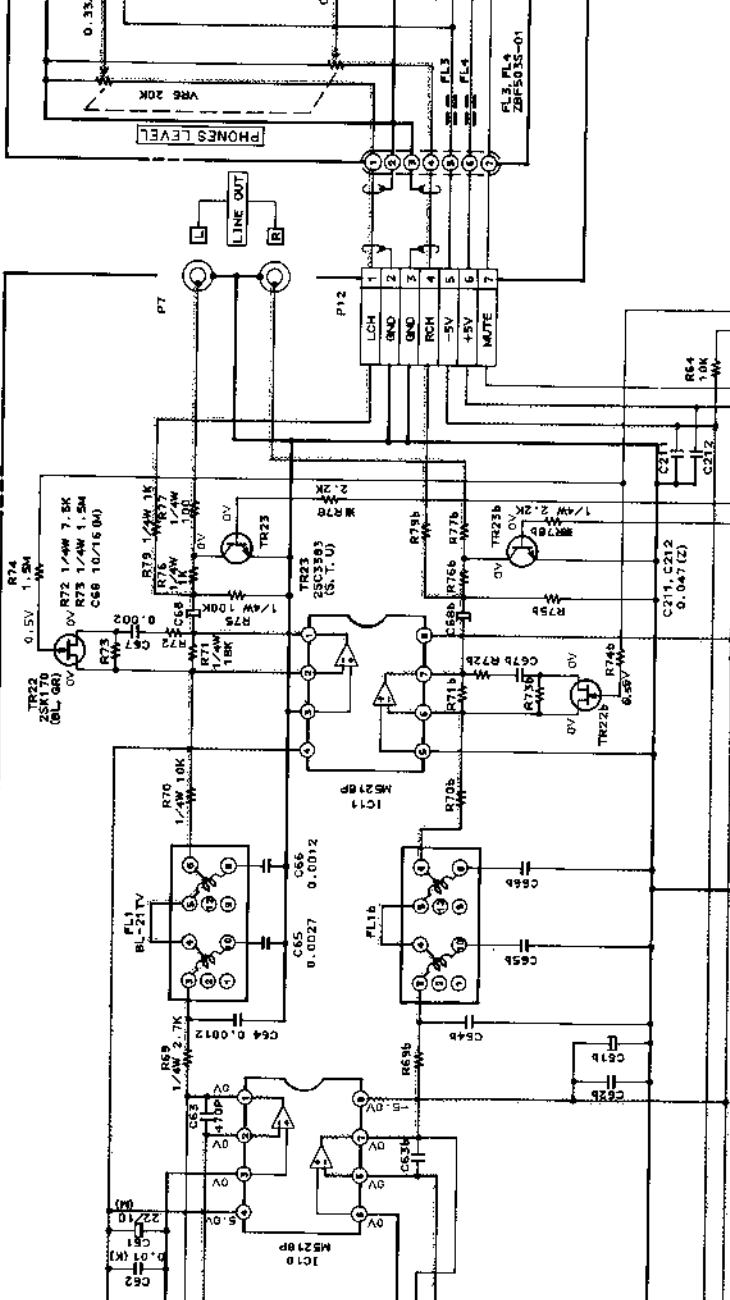
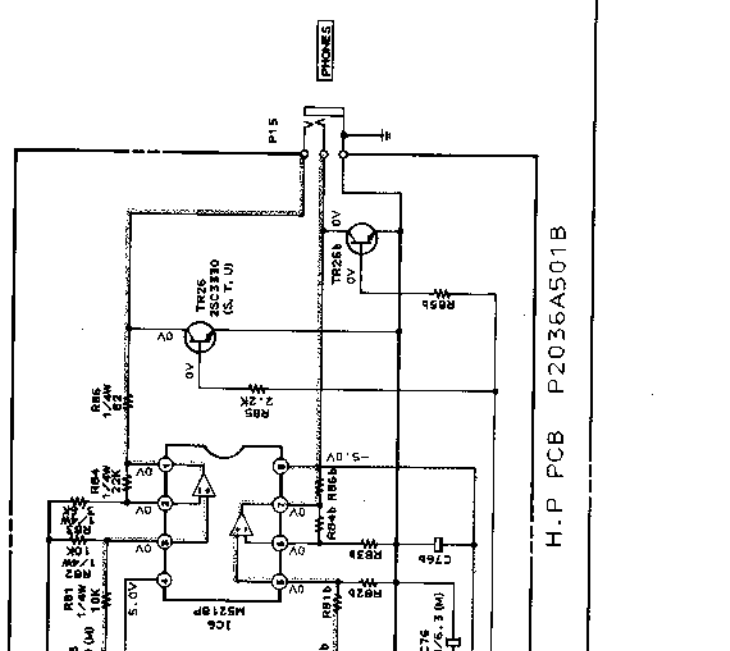
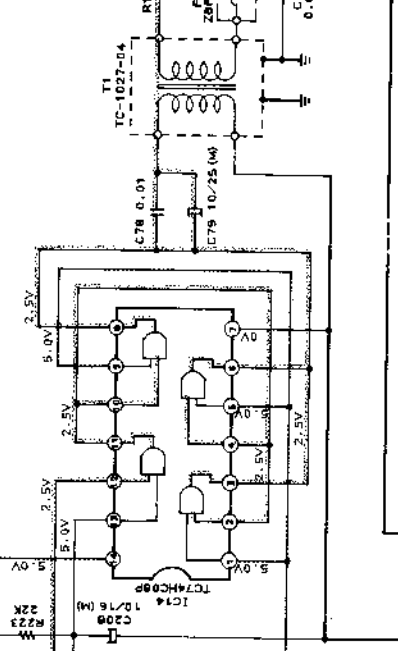
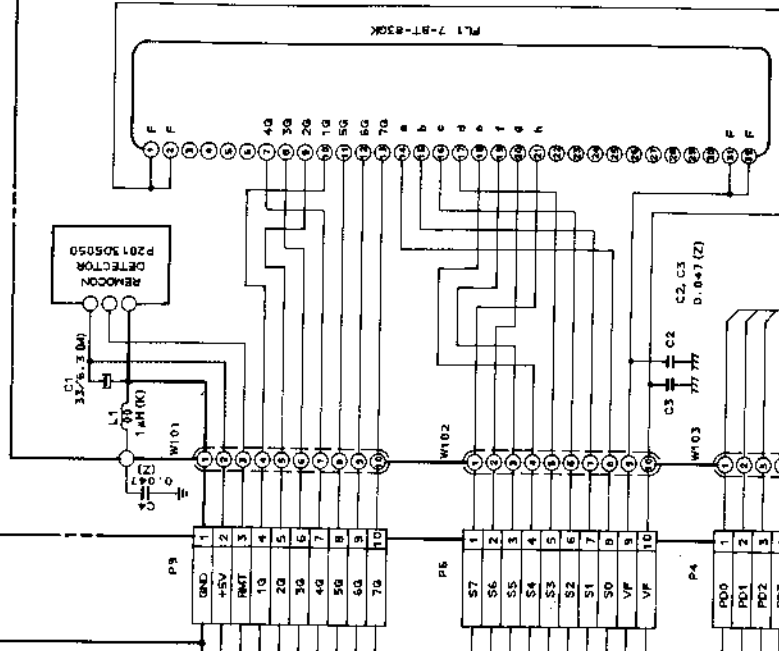
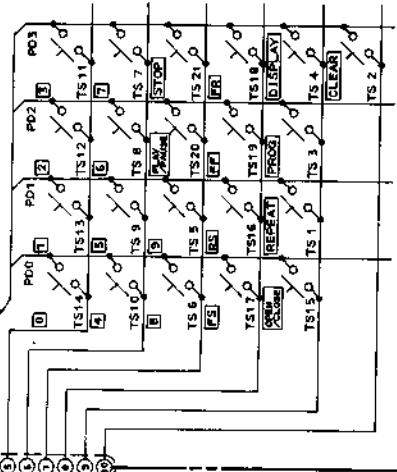
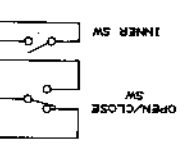

F G H J K

1 2 3 4 5 6 7 8

PHONES LEVEL

LINE OUT

PHONES

DIGITAL OUTPUT

SPINDLE MOTOR

SLIDE MOTOR

LINE OUT

INNER SW

OPEN/CLOSE SW

LOADING MOTOR

RD-650V-10240

RF-310T1400

RF-518T12620

ICB P2036A501A

OPERATION PCB P2036A5020

H.P. PCB P2036A501B

CD-32

SCHEMATIC DIAGRAM

NO. 871209A

NOTE

UNLESS OTHERWISE SPECIFIED

ALL RESISTORS IN OHMS 1/4W (J)

ALL CAPACITORS IN PF 50WV (J)

DESIGNED BY DIGITAL VOLTMETER IN PLAY MODE

ICB P2036A501A

OPERATION PCB P2036A5020

H.P. PCB P2036A501B

CD-32

SCHEMATIC DIAGRAM

NO. 871209A

NOTE

UNLESS OTHERWISE SPECIFIED

ALL RESISTORS IN OHMS 1/4W (J)

ALL CAPACITORS IN PF 50WV (J)

DESIGNED BY DIGITAL VOLTMETER IN PLAY MODE

ICB P2036A501A

OPERATION PCB P2036A5020

H.P. PCB P2036A501B

CD-32

SCHEMATIC DIAGRAM

NO. 871209A

NOTE

UNLESS OTHERWISE SPECIFIED

ALL RESISTORS IN OHMS 1/4W (J)

ALL CAPACITORS IN PF 50WV (J)

DESIGNED BY DIGITAL VOLTMETER IN PLAY MODE

ICB P2036A501A

OPERATION PCB P2036A5020

H.P. PCB P2036A501B

CD-32

SCHEMATIC DIAGRAM

NO. 871209A

NOTE

UNLESS OTHERWISE SPECIFIED

ALL RESISTORS IN OHMS 1/4W (J)

ALL CAPACITORS IN PF 50WV (J)

DESIGNED BY DIGITAL VOLTMETER IN PLAY MODE

ICB P2036A501A

OPERATION PCB P2036A5020

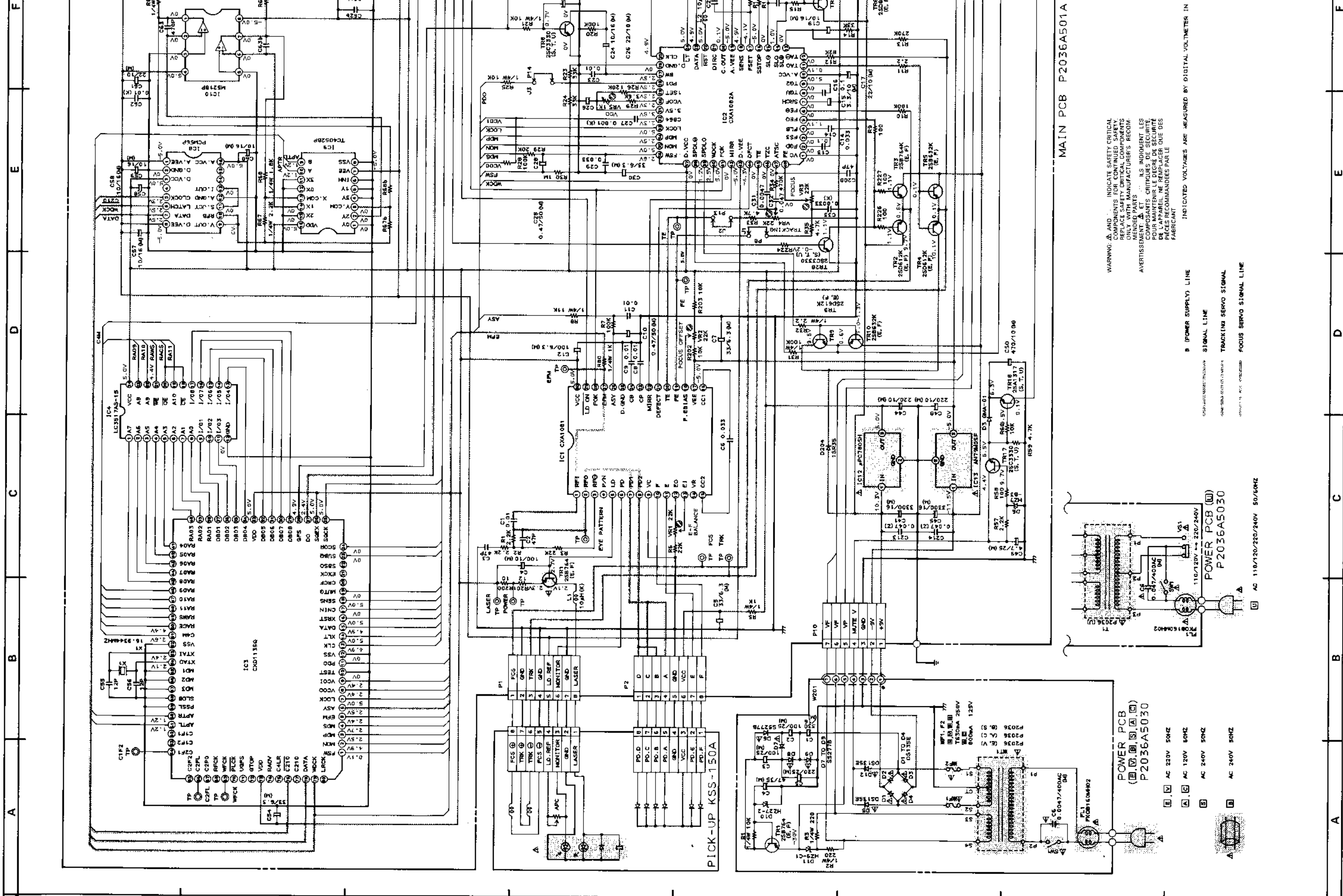

MAIN PCB P2036A501A

WARNING: Δ AND ∇ INDICATE SAFETY CRITICAL COMPONENTS. ONLY WITH MANUFACTURER'S RECOMMENDATIONS. AVERTISSEMENT: Δ ET ∇ INDICENT LES COMPOSANTS CRITIQUES DE SECURITE. POUR MANUTENIR LE DEGRE DE SECURITE DE L'APPAREIL, NE REMPLACER QUE DES PIÈCES RECOMMANDÉES PAR LE FABRICANT.

INDICATED VOLTAGES ARE MEASURED BY DIGITAL VOLTMETER IN PLAY MODE

□ B (POWER SUPPLY) LINE
 ○ SIGNAL LINE
 ○ TRACKING SERVO SIGNAL
 ○ FOCUS SERVO SIGNAL

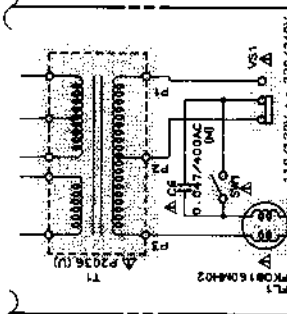

POWER PCB P2036A5030

- AC 220V 50HZ
- AC 120V 60HZ
- AC 240V 50HZ
- AC 240V 50HZ

AC 110/120/220/240V 50/60HZ

Parts Locations

Transistors

- TR1. B4
- TR2. C3
- TR3. D4
- TR4~7. . . . E3
- TR8. D2
- TR9, 10. . . . C3
- TR17~19. . . . A2
- TR20. D1
- TR21. A2
- TR22, 23. . . . A2
- TR22b, 23b. . . . A1

IC's

- IC1, 2. C3
- IC3. D1
- IC4. E1
- IC5. F1
- IC8. C1
- IC9, 10. . . . B1
- IC11. A1
- IC12. B3
- IC13, 14. . . . A3

Connectors

- P1. B4
- P2. C4
- P3. E3
- P4. F2
- P5. F3
- P6. F2
- P7. A1
- P8. C3
- P9. F1
- P10. B4
- P11. A4
- P12. A1
- P13. C3
- P14. D2

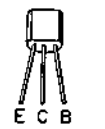

2SA13192
2SC3383

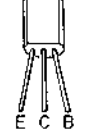

2SB764
2SD863

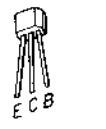

2SA1317
2SC3330

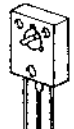

2SB632K
2SD612K

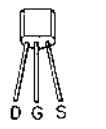

2SK170

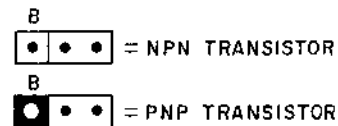

WARNING: ▲ INDICATES SAFETY CRITICAL COMPONENTS. FOR CONTINUED SAFETY, REPLACE SAFETY CRITICAL COMPONENTS ONLY WITH MANUFACTURER'S RECOMMENDED PARTS.

AVERTISSEMENT: ▲ ILL INDIQUE LES COMPOSANTS CRITIQUES DE SÉCURITÉ. POUR MAINTENIR LE DEGRÉ DE SÉCURITÉ DE L'APPAREIL, NE REMPLACER QUE DES PIÈCES RECOMMANDÉES PAR LE FABRICANT.

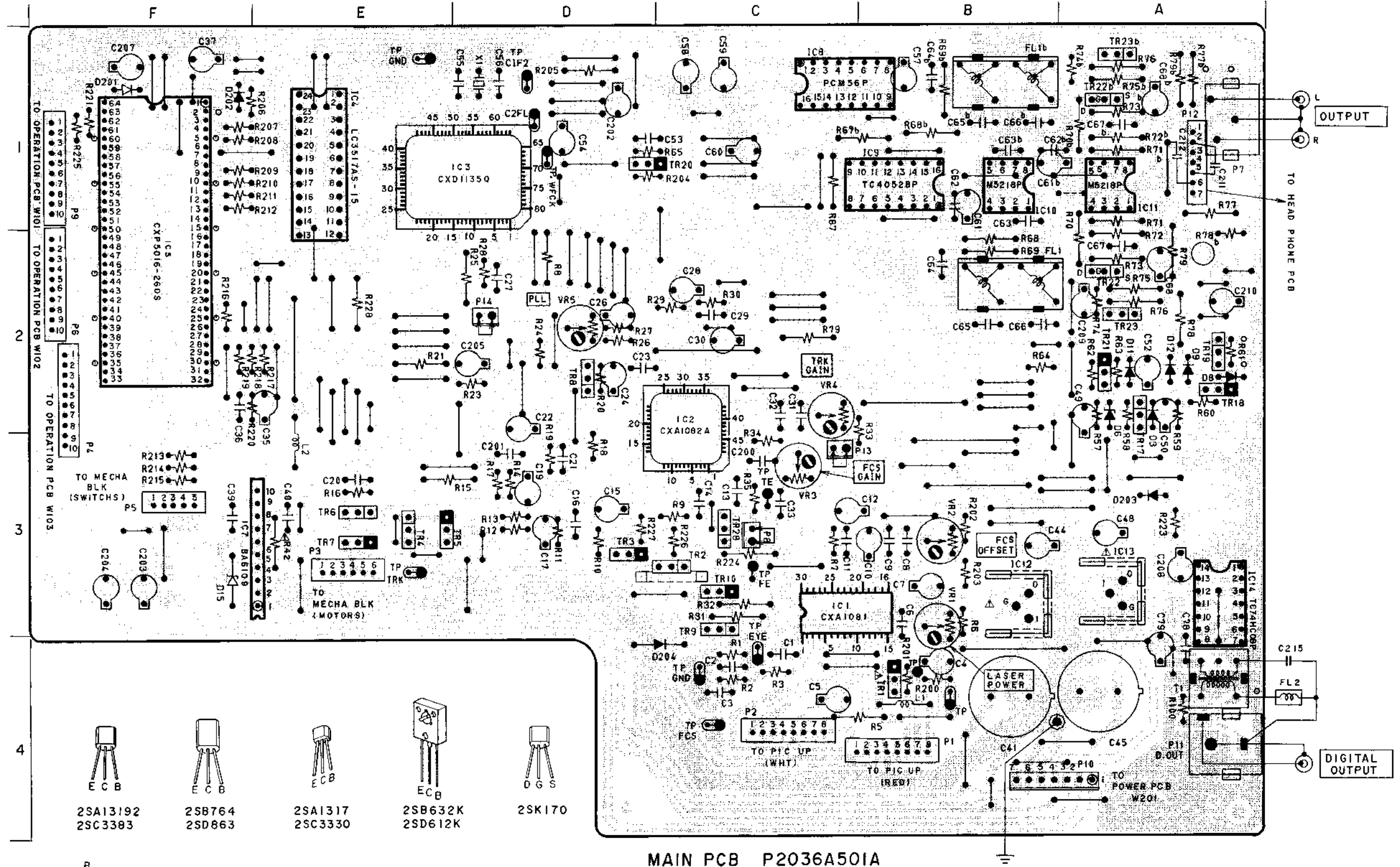

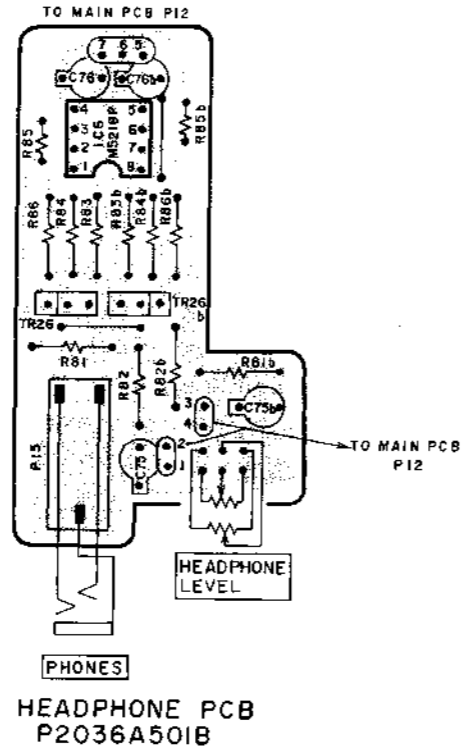

HEADPHONE PCB
P2036A501B

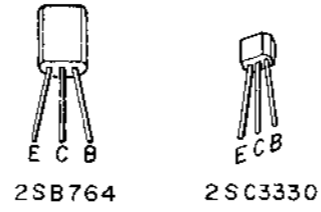

2SB764 2SC3330

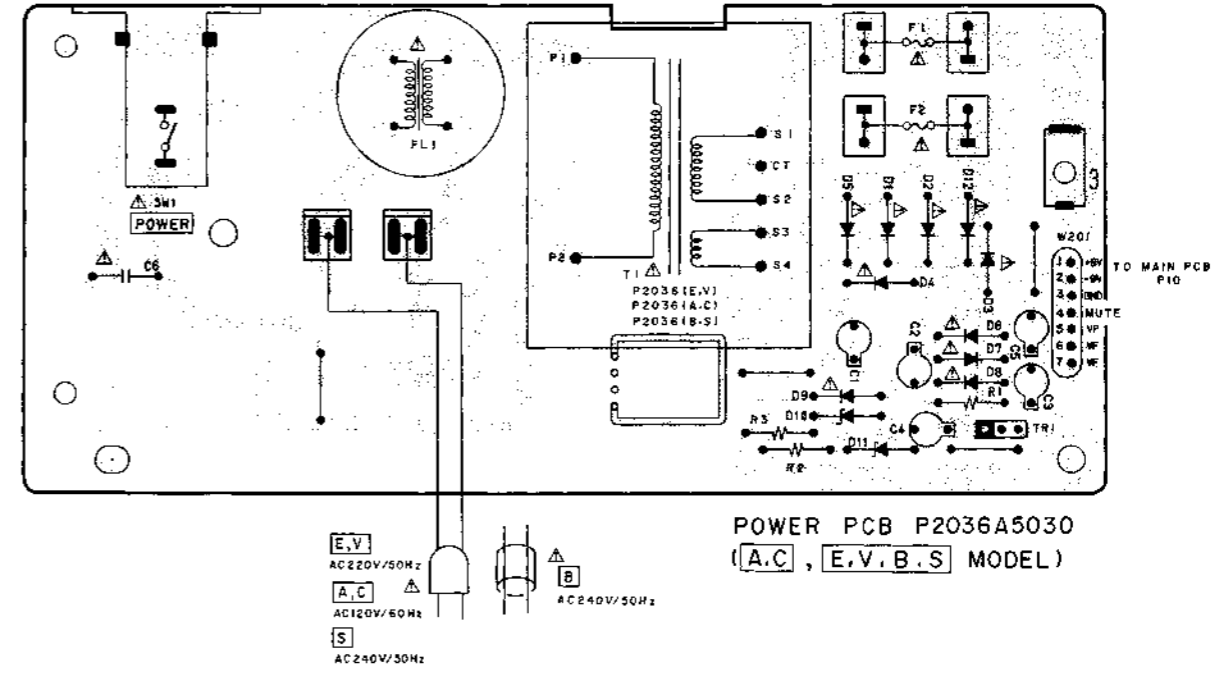
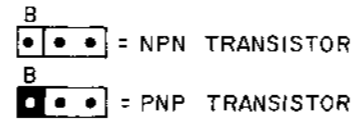

POWER PCB P2036A5030
(A.C., E.V., B.S. MODEL)

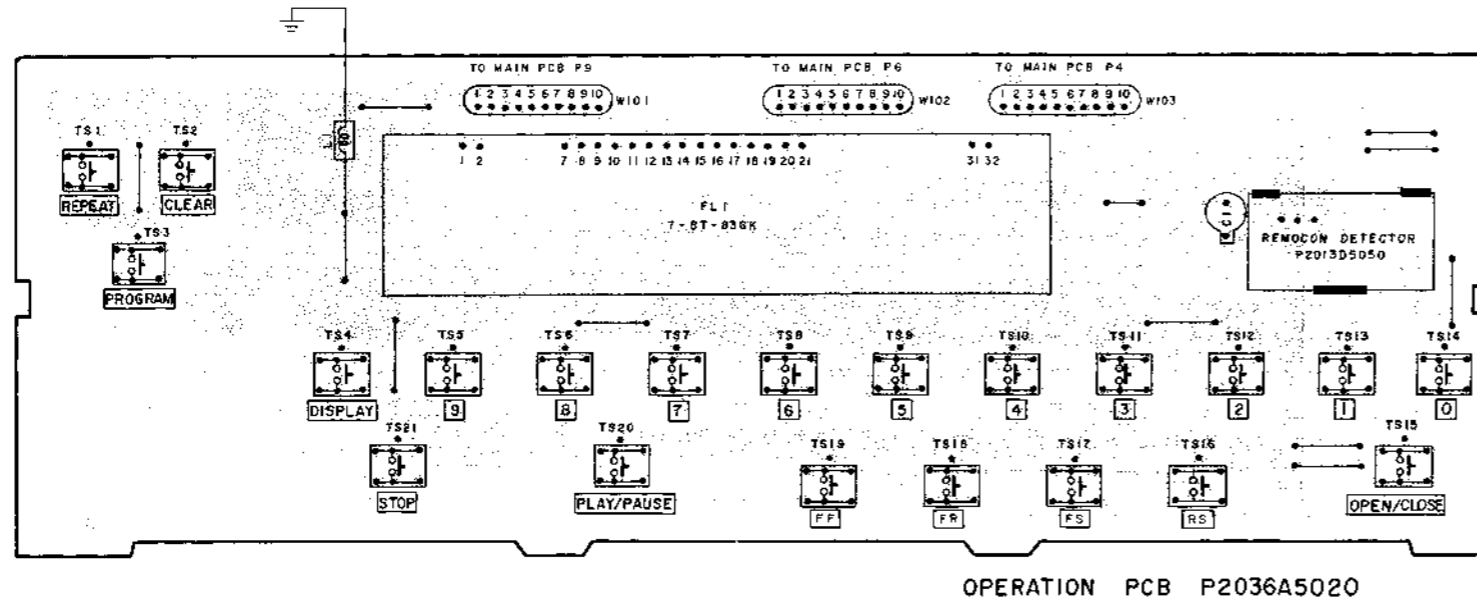

OPERATION PCB P2036A5020

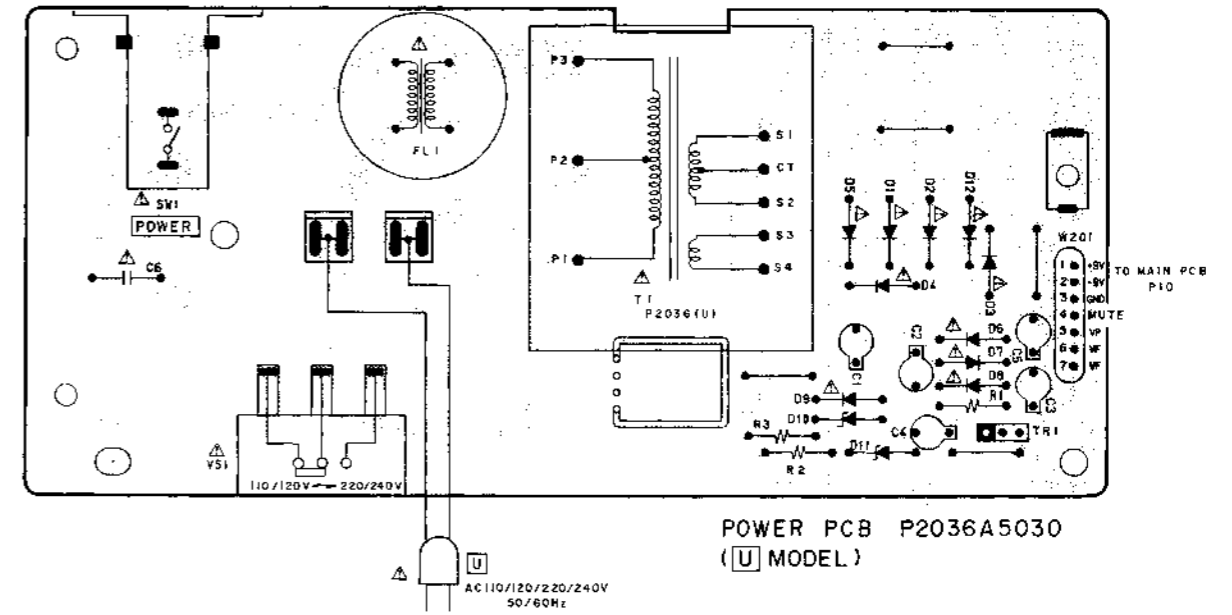

POWER PCB P2036A5030
(U MODEL)





WARNING: INDICATES SAFETY CRITICAL COMPONENTS. FOR CONTINUED SAFETY, REPLACE SAFETY CRITICAL COMPONENTS ONLY WITH MANUFACTURER'S RECOMMENDED PARTS.
 AVERTISSEMENT: IL INDIQUE LES COMPOSANTS CRITIQUES DE SÉCURITÉ. POUR MAINTENIR LE DEGRÉ DE SÉCURITÉ DE L'APPAREIL, NE REMPLACER QUE DES PIÈCES RECOMMANDÉES PAR LE FABRICANT.

VII. ELECTRICAL ADJUSTMENT (SERVO)

ABOUT THE TEST MODE

- This test mode is used for the adjustment or check.
- Turn on the power while pressing the 0, 1 and 2 key switches on the FRONT PANEL, then machine set to the TEST MODE.
- Indication of the FRONT PANEL is "0 ES:-0" when TEST MODE.
- When change the TEST MODE number, press the  key switch on the FRONT PANEL.
- When press the STOP key switch, TEST MODE number return to "0 ES:-0".
- When release from test mode, turn the power off.

TEST MODE OPERATION, DISPLAY AND FUNCTION

OPERATION	DISPLAY	FUNCTION
POWER OR STOP	0 ES:-0	LASER OFF ALL SERVO OFF
FS 	1 ES:-1	LASER ON
FS 	2 ES:-2	FOCUS SERVO ON
FS 	3 ES:-3	SPINDLE MOTOR ON AUDIO MUTE OFF*
FS 	4 ES:-4	TRACKING SERVO ON SLIDE SERVO ON

* This function activated only Focus ok (Focus servo ok)

STEP	ADJUSTMENT ITEM
1.	Test Disc
2.	Mode
3.	Test Point & Adj. Part
4.	Result & Remarks



3 E-F BALANCE

1. Test Disc 5A (AT-751330)
2. Test mode 3.
3. Connect an Oscilloscope between TP (TE) and GND.
4. VR1
5. A = B (DC Range)

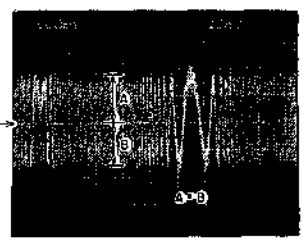

5 TRACKING SERVO GAIN

1. Test Disc 5A (AT-751330)
2. Disc play
3. Connect an Oscilloscope between TP (TRK) and GND.
4. VR4
5. 800mV~1.2VP-P



1 PLL FREQUENCY

1. —
2. Power ON
3. Connect a Frequency Counter between TP (WFCK) and GND. Disconnect a short connector P14.
4. VR5
5. 6350±10Hz

* Connect a short connector P14 after this adjustment.

2 FOCUS OFF-SET

1. Test Disc 5A (AT-751330)
2. Test mode 2 and 0
3. Connect a Digital Voltmeter between TP (FE) and GND. Check the voltage A. (Test mode 2)
4. VR2
5. Press STOP key. And adjustment voltage B so that the voltage same as voltage A. (Test mode 0)

* Confirm while test mode 2. Creaky noise from pick up, when turn the compact disc by finger.

4 FOCUS SERVO GAIN

1. Test Disc 5A (AT-751330)
2. Disc play.
3. Connect an Oscilloscope between TP (FCS) and GND.
4. VR3
5. 1.0mV~1.4mVP-P

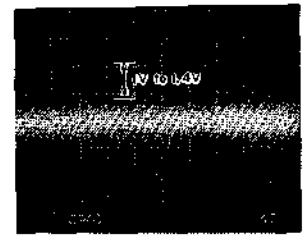
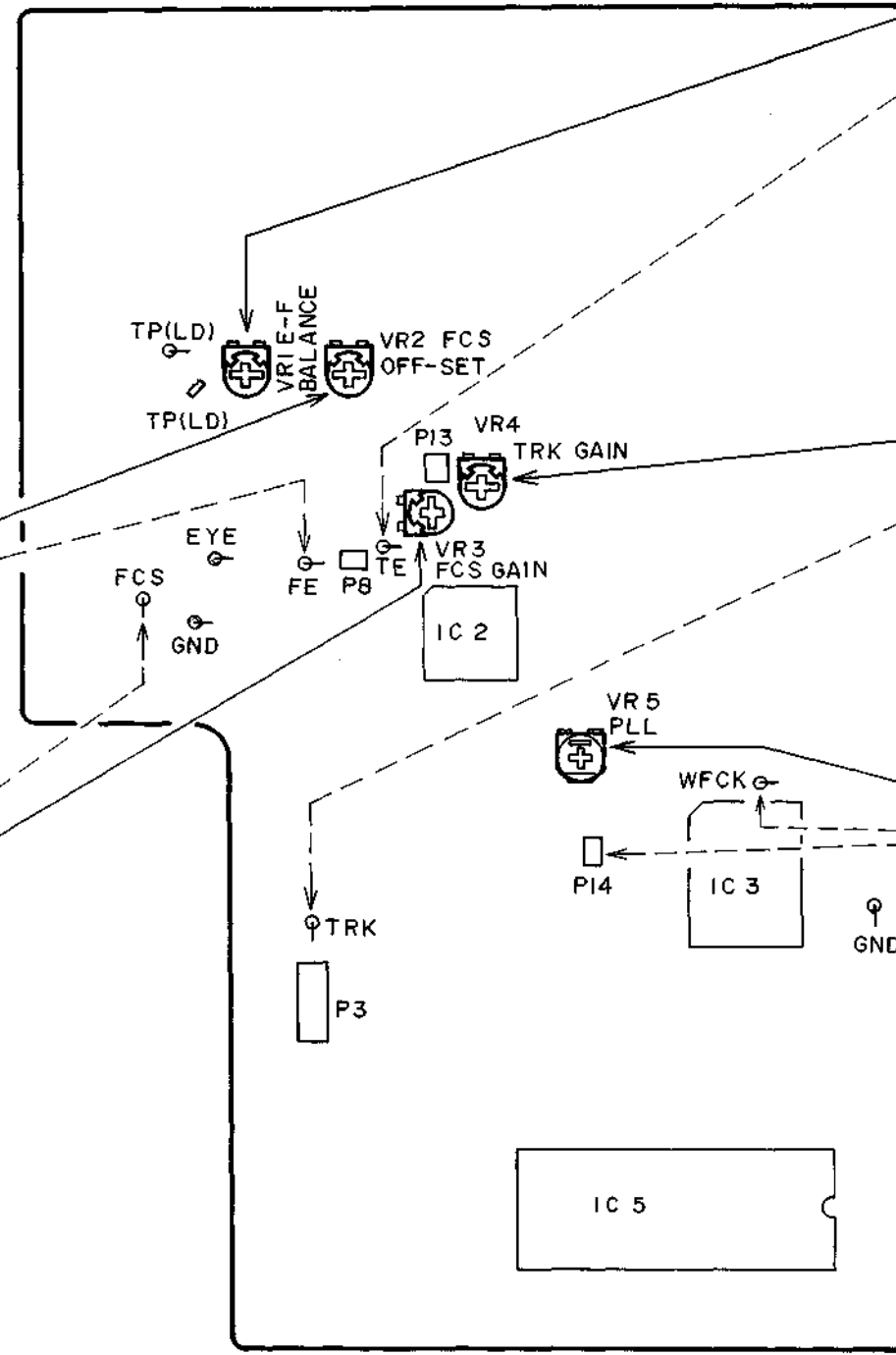
MAIN PCB

VIII. PARTS LIST

ATTENTION

- When placing an order for parts, be sure to list Part No., Model No. and the description of each part. Otherwise, the non-delivery of the part or the delivery of a wrong part may result.
- Please make sure that Part No. is correct when ordering. If not, a part different from the one you ordered may be delivered.
- Since the parts shown in Parts List of Preliminary Service Manual may have been the subject of changes, please use this Parts List for all future reference.

HOW TO USE THIS PARTS LIST

- This Parts List lists those parts which are considered necessary for repairs. Other common parts, such as resistors and capacitors, are listed in the "Common List for Service Parts" from which these parts should be selected and stocked.
- The Recommended Spare Parts List shows those parts in the Parts List which are considered particularly important for service.
- Parts not shown in the Parts List and "Common List for Service Parts" will not in principle be supplied.
- How to read the Parts List.

a) Mechanism Block

2. HEAD BASE BLOCK

REF. NO.	PART NO.	DESCRIPTION
2-1x	BH-T2023A320A	HEAD BASE BLOCK
2-2	HP-H2206A010A	HEAD R/P PR4-8FU C
2-3	ZS-477876	PAN20x03STL CMT
2-4	ZS-536488	BID20x08STL CMT
2-5	ZG-402895	SP CS ANGLE ADJUST

SP (Service Parts) Classification

A small "x" indicates that this part is not shown in the Photo or Illustration.

This number corresponds with the individual parts index number in that figure.

This number corresponds with the Figure Number.

b) PC Board

6. MAIN PC BOARD

REF. NO.	PART NO.	DESCRIPTION
6-IC1	EI-324536	IC HD14049BP
6-IC2	EI-336801	IC MB8841-564M
6-C1A	EC-338399	C MMY V 223M 250AC [U,E,B,S]
6-C1B	EC-350949	C MMY V 223M 250DC [J]
6-C1C	EC-338397	C MMY V 223M 125AC [C,A]
6-X1	EI-318384	OSC X'TAL NC-18C

Symbols for primary destination

[A]: AAL(U.S.A.) [S]: SAA(Australia)
 [B]: BEAB(England) [U]: U/T(Universal Area)
 [C]: CSA(Canada) [V]: VDE(W. Germany)
 [E]: CEE(Europe) [Y]: Custom Version
 [J]: JPN(Japan)

SP (Service Parts) Classification

These reference symbols correspond with component symbols in the Schematic Diagrams.

The available PC Board Blocks are listed separately.

- When Part No. is known, Parts Index at end of Parts List can be used to locate where that part is shown in Parts List by its Reference No. listed at right of Part No.

WARNING

⚠ (*) INDICATES SAFETY CRITICAL COMPONENTS. FOR CONTINUED SAFETY, REPLACE SAFETY CRITICAL COMPONENTS ONLY WITH MANUFACTURE'S RECOMMENDED PARTS.

AVERTISSEMENT

⚠ (*) IL INDIQUE LES COMPOSANTS CRITIQUES DE SÉCURITÉ. POUR MAINTENIR LE DEGRÉ DE SÉCURITÉ DE L'APPAREIL, NE REMPLACER QUE DES PIÈCES RECOMMANDÉES PAR LE FABRICANT.

1. RECOMMENDED SPARE PARTS

Ref. No.	Part No.	Description
1	BB-P2036A060A	MECHA BLK CD-32
2	BM-B328441X1	SC MOTOR LOADING PART [LOADING MOTOR]
3	BM-B371552X1	SC MOTOR SLIDE PART [SLIDE MOTOR]
4	BM-B372237X1	SC MOTOR SPINDLE PART [SPINDLE MOTOR]
5	BO-368598	PICK UP KSS-150A
6	*BT-378169	TRANS POW P2036(A,C) [C.A]
7	*BT-378171	TRANS POW P2036(B,S) [B.S]
8	*BT-378170	TRANS POW P2036(E,V) [E.V]
9	*BT-378168	TRANS POW P2036(U) [U]
10	BT-368261	TRANS PULSE TC-1027-04
11	ED-360409	D PHOTO PN323B
12	ED-344280	D SILICON H GMA-01-FY2 F05
13	*ED-330622	D SILICON 1SR35-100VL 100/1.0A
14	ED-346620	D ZENER H HZ27 2
15	ED-346529	D ZENER H HZ6L C2
16	ED-305706	D ZENER H HZ7 B3
17	ED-346609	D ZENER H HZ9 C1
18	*EF-358974	FUSE BET T 250V 630MA [B.S]
19	*EF-601942	FUSE SEMKO T 250V 630MA [E.V]
20	*EF-309391	FUSE TSC 125V 800MA [A.C]
21	EH-380185J	FILTER EMI ZBF503S-01
22	EH-380561J	FILTER LC LP BL-21TV 20KHZ
23	EI-330352	IC BA6109
24	EI-368608	IC CXA1081
25	EI-368609	IC CXA1082A
26	EI-368610	IC CXD1135Q
27	EI-379885J	IC CXP5016H-260S CUSTOM
28	EI-368611	IC LC3517AS-15
29	EI-349719	IC M5218P
30	EI-368612	IC PCM56P
31	EI-332259	IC TC4052BP
32	EI-360039	IC TC74HC08P
33	EI-367271	IC UPC1490HA
34	*EI-371572	IC UPC7805H
35	*EI-377246	IC UPC79M05HF
36	EI-374176	OSC X'TAL AT-51 16.9344MHZ
37	EM-374177	IND FL 7-BT-83GK
38	*EO-338409	COIL LF FK0B160MH02 250UH
39	*ER-328278	R FUSE H ERD2FC 1/4W 10R0G
40	ES-368603	SW LEAF MSW-1585 [OPEN/CLOSE SW]
41	*ES-371104	SW PUSH SDDL1082A 01-1 [POWER SW]
42	ES-355842	SW SLIDE SSCTP1026A 1-01-02S [INNER SW]
43	*ES-349464	SW SLIDE 00120319 01-2 [U][VOLTAGE SELECTOR]
44	ES-373381	SW TACT SKHHP
45	ET-354897	TR FET 2SK170 BL,GR,V
46	ET-353899	TR 2SA1317 S.T.U
47	ET-352726	TR 2SA1392 T.U
48	ET-322598	TR 2SB832K E,F
49	ET-318237	TR 2SB764 E,F
50	ET-360067	TR 2SC3330 T.U F05
51	ET-378524J	TR 2SC3383 S.T.U
52	ET-310148	TR 2SD612K E,F
53	ET-200986	TR 2SD863-V8 F
54	EV-378175	VR ROTARY RK0971220 B203X2 [HEADPHONE LEVEL]
55	MB-368590	BELT LOADING
56	MZ-374138	CAM GEAR LOADING
57	MZ-368349	GEAR WORM WHEEL

2. MECHA BLOCK

Ref. No.	Part No.	Description
2	BO-368598	PICK UP KSS-150A
3	EW-368599	WIRE ASSY OT-M1 PU1 8P
4	EW-368600	WIRE ASSY OT-M1 PU2 8P
5	MS-368348	SHAFT
6	BM-B372237X1	SC MOTOR SPINDLE PART [SPINDLE MOTOR]
7	ZS-367463	PAN20X025STL CMT
8	MB-368350	CUSHION RUBBER
9	BM-B328441X1	SC MOTOR LOADING PART [LOADING MOTOR]
10	MZ-368349	GEAR WORM WHEEL
11	BM-B371552X1	SC MOTOR SLIDE PART [SLIDE MOTOR]
12	ES-368603	SW LEAF MSW-1585 [OPEN/CLOSE SW]
13	ES-355842	SW SLIDE SSCTP1026A 1-01-02S [INNER SW]
14	ZS-536488	BID20X08STL CMT
15	ZS-343082	PT BR 26X08STL CMT
16	MR-374137	PULLEY GEAR
17	MB-368590	BELT LOADING
18	MZ-374138	CAM GEAR LOADING
19	ZS-365391	PT BR30X08STL CMT C080
20	MZ-368347	CLAMPER
21	SZ-374136J1	HOLDER CLAMPER
22	ZG-368591	SP PUSH CLAMP
23	SC-B374139	DISK TRAY PART
24	MB-377975	STOPPER RUBBER
25	MB-378827J	STOPPER RUBBER(B)
26	ZS-378395	SD 30X20STL CMT L=11
27	MZ-378828J	ANGLE TRAY
28	ZS-432843	PAN26X04STL CMT

3. P.C BOARD BLOCK

Ref. No.	Part No.	Description
1A	BA-P2036A030A	PC(★) MAIN BLK CD-32(U) [U,C,A,E,B,S]
1B	BA-P2036A030B	PC(★) MAIN BLK CD-32(V) [V]

NOTE: PC(★) MAIN BLK CONSISTS OF FOLLOWING P.C BOARD
 • MAIN P.C BOARD
 • HEADPHONE P.C BOARD

MECHA BLOCK

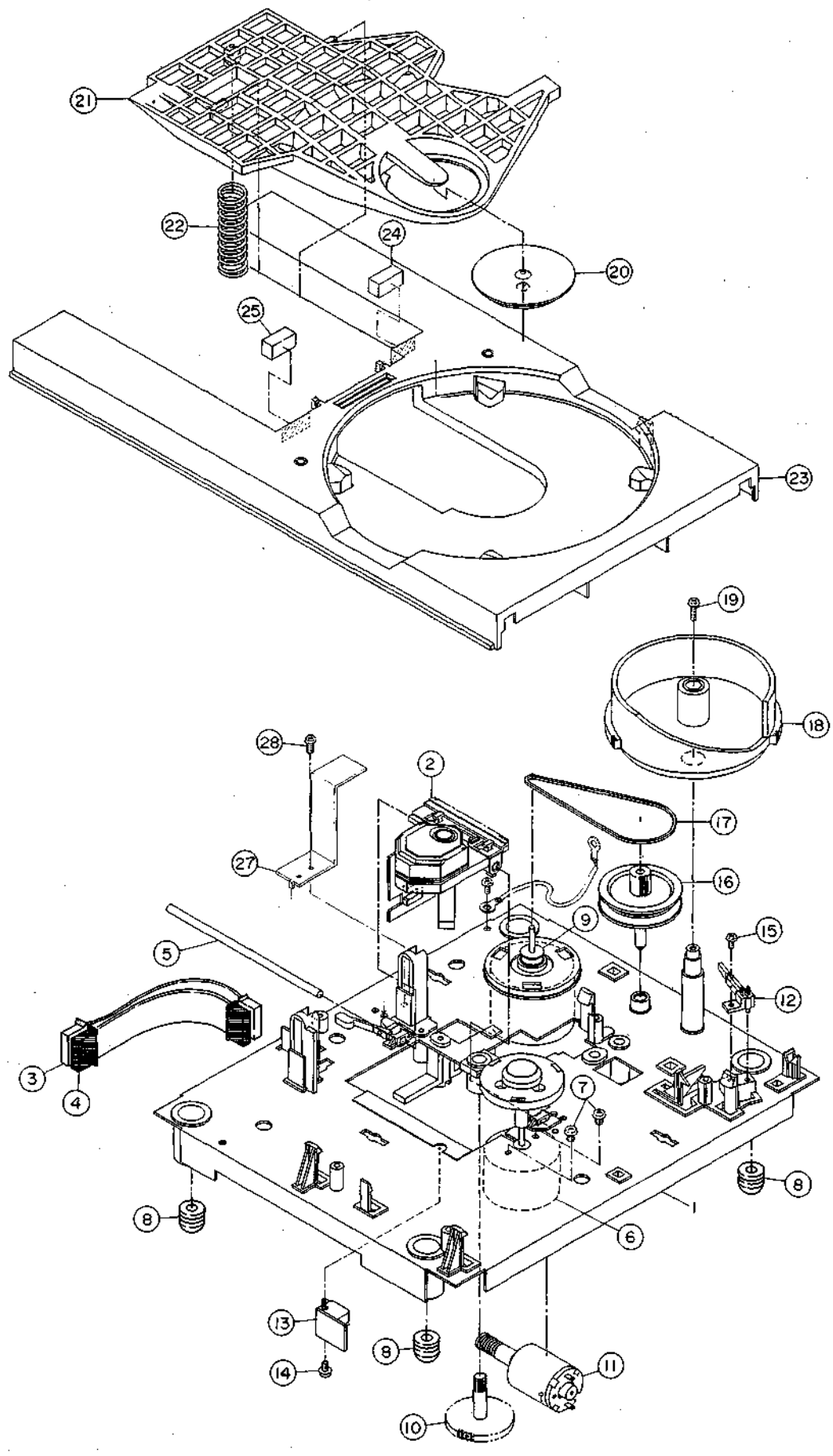

PARTS LIST

4. MAIN P.C BOARD

Ref. No.	Part No.	Description
D3	ED-344280	D SILICON H GMA-01-FY2 F05
D6	ED-305706	D ZENER H HZ7 B3
D8	ED-344280	D SILICON H GMA-01-FY2 F05
D9	ED-344280	D SILICON H GMA-01-FY2 F05
D11	ED-344280	D SILICON H GMA-01-FY2 F05
D12	ED-344280	D SILICON H GMA-01-FY2 F05
D15	ED-346529	D ZENER H HZ6L C2
D201	ED-344280	D SILICON H GMA-01-FY2 F05
D202	ED-344280	D SILICON H GMA-01-FY2 F05
D203	ED-344280	D SILICON H GMA-01-FY2 F05
D204	ED-330622	D SILICON 1SR35-100VL 100/1.0A
FL1	EH-380561J	FILTER LC LP BL-21TV 20KHZ
FL2	EH-380185J	FILTER EMI ZBF503S-01
IC1	EI-368608	IC CXA1081
IC2	EI-368609	IC CXA1082A
IC3	EI-368610	IC CXD1135Q
IC4	EI-368611	IC LC3517AS-15
IC5	EI-379865J	IC CXP5016H-260S CUSTOM
IC7	EI-330362	IC BA6109
IC8	EI-368612	IC PGM56P
IC9	EI-332259	IC TC4052BP
IC10	EI-349719	IC M5218P
IC11	EI-349719	IC M5218P
IC12	*EI-371572	IC UPC7805H
IC13	*EI-377246	IC UPC79M05HF
IC14	EI-360039	IC TC74HC08P
L1	EO-345913	COIL FIX 1 LAL03KH 100K
L2	EO-345913	COIL FIX 1 LAL03KH 100K
P7	EJ-337424	PIN J AJC-034-ABB P 2P [LINE OUT]
P11	EJ-376482	PIN J YKB11-0422 1P [DIGITAL OUT]
R42	*ER-328278	R FUSE H ERD2FC 1/4W 10ROG
TR1	ET-318237	TR 2SB764 E.F
TR2	ET-310148	TR 2SD612K E.F
TR3	ET-318237	TR 2SB764 E.F
TR4	ET-310148	TR 2SD612K E.F
TR5	ET-322598	TR 2SB632K E.F
TR6	ET-200986	TR 2SD863-V8 F
TR7	ET-318237	TR 2SB764 E.F
TR8	ET-360067	TR 2SC3330 T,U F05
TR9	ET-310148	TR 2SD612K E.F
TR10	ET-322598	TR 2SB632K E.F
TR17	ET-360067	TR 2SC3330 T,U F05
TR18	ET-353899	TR 2SA1317 S,T,U
TR19	ET-360067	TR 2SC3330 T,U F05
TR20	ET-352726	TR 2SA1392 T,U
TR21	*ET-353899	TR 2SA1317 S,T,U
TR22	ET-354897	TR FET 2SK170 BL.GR.V
TR23	ET-378524J	TR 2SC3383 S,T,U
TR28	ET-360067	TR 2SC3330 T,U F05
T1	BT-368261	TRANS PULSE TC-1027-04
VR1	EV-358829	R S-FIX H RH0615C 0.10W 223
VR2	EV-358829	R S-FIX H RH0615C 0.10W 223
VR3	EV-358829	R S-FIX H RH0615C 0.10W 223
VR4	EV-358829	R S-FIX H RH0615C 0.10W 223
VR5	EV-371279	R S-FIX H VM6CKPVB 0.30W 102
X1	EI-374176	OSC X'TAL AT-51 16.9344MHZ

5. HEADPHONE P.C BOARD

Ref. No.	Part No.	Description
IC6	EI-349719	IC M5218P
P15	EJ-380297J	PHONE J 3P HLJ0540-410 GP 6.3 [HEADPHONE]
TR26	ET-360067	TR 2SC3330 T,U F05
VR6	EV-378175	VR ROTARY RK0971220 B203X2 [HEADPHONE LEVEL]

6. OPERATION P.C BOARD

Ref. No.	Part No.	Description
FL1	EM-374177	IND FL 7-BT-83GK
L1	EO-345902	COIL FIX 1 LAL03KH 1ROM
TS1	ES-373381	SW TACT SKHHPP
TS2	ES-373381	SW TACT SKHHPP
TS3	ES-373381	SW TACT SKHHPP
TS4	ES-373381	SW TACT SKHHPP
TS5	ES-373381	SW TACT SKHHPP
TS6	ES-373381	SW TACT SKHHPP
TS7	ES-373381	SW TACT SKHHPP
TS8	ES-373381	SW TACT SKHHPP
TS9	ES-373381	SW TACT SKHHPP
TS10	ES-373381	SW TACT SKHHPP
TS11	ES-373381	SW TACT SKHHPP
TS12	ES-373381	SW TACT SKHHPP
TS13	ES-373381	SW TACT SKHHPP
TS14	ES-373381	SW TACT SKHHPP
TS15	ES-373381	SW TACT SKHHPP
TS16	ES-373381	SW TACT SKHHPP
TS17	ES-373381	SW TACT SKHHPP
TS18	ES-373381	SW TACT SKHHPP
TS19	ES-373381	SW TACT SKHHPP
TS20	ES-373381	SW TACT SKHHPP
TS21	ES-373381	SW TACT SKHHPP

7. SENSOR C P.C BOARD

Ref. No.	Part No.	Description
D1	ED-360409	D PHOTO PN323B
IC1	EI-367271	IC UPC1490HA

8. POWER SUPPLY P.C BOARD

Ref. No.	Part No.	Description
C6	*EC-338496	C CE V FZ 472P 400AC
D1	*ED-330622	D SILICON 1SR35-100VL 100/1.0A
D2	*ED-330622	D SILICON 1SR35-100VL 100/1.0A
D3	*ED-330622	D SILICON 1SR35-100VL 100/1.0A
D4	*ED-330622	D SILICON 1SR35-100VL 100/1.0A
D5	*ED-330622	D SILICON 1SR35-100VL 100/1.0A
D6	*ED-330622	D SILICON 1SR35-100VL 100/1.0A
D7	*ED-330622	D SILICON 1SR35-100VL 100/1.0A
D8	*ED-330622	D SILICON 1SR35-100VL 100/1.0A
D9	*ED-330622	D SILICON 1SR35-100VL 100/1.0A
D10	ED-346620	D ZENER H HZ27 2
D11	ED-346609	D ZENER H HZ9 C1
D12	*ED-330622	D SILICON 1SR35-100VL 100/1.0A
SW1	*ES-371104	SW PUSH SDDL1082A 01-1 [POWER SW]
TR1	ET-318237	TR 2SB764 E.F
VS1	*ES-349464	SW SLIDE 00120319 01-2 [U] [VOLTAGE SELECTOR]
T1A	*BT-378168	TRANS POW P2036(U) [U]
T1B	*BT-378169	TRANS POW P2036(A,C) [C,A]
T1C	*BT-378170	TRANS POW P2036(E,V) [E,V]
T1D	*BT-378171	TRANS POW P2036(B,S) [B,S]
FL1	*EO-338409	COIL LF FK0B160MH02 250UH
F1A	*EF-309391	FUSE TSC 125V 800MA [A,C]
F2A	*EF-309391	FUSE TSC 125V 800MA [A,C]
F1B	*EF-601942	FUSE SEMKO T 250V 630MA [E,V]
F2B	*EF-601942	FUSE SEMKO T 250V 630MA [E,V]
F1C	*EF-358974	FUSE BET T 250V 630MA [B,S]
F2B	*EF-358974	FUSE BET T 250V 630MA [B,S]

FINAL ASSEMBLY BLOCK

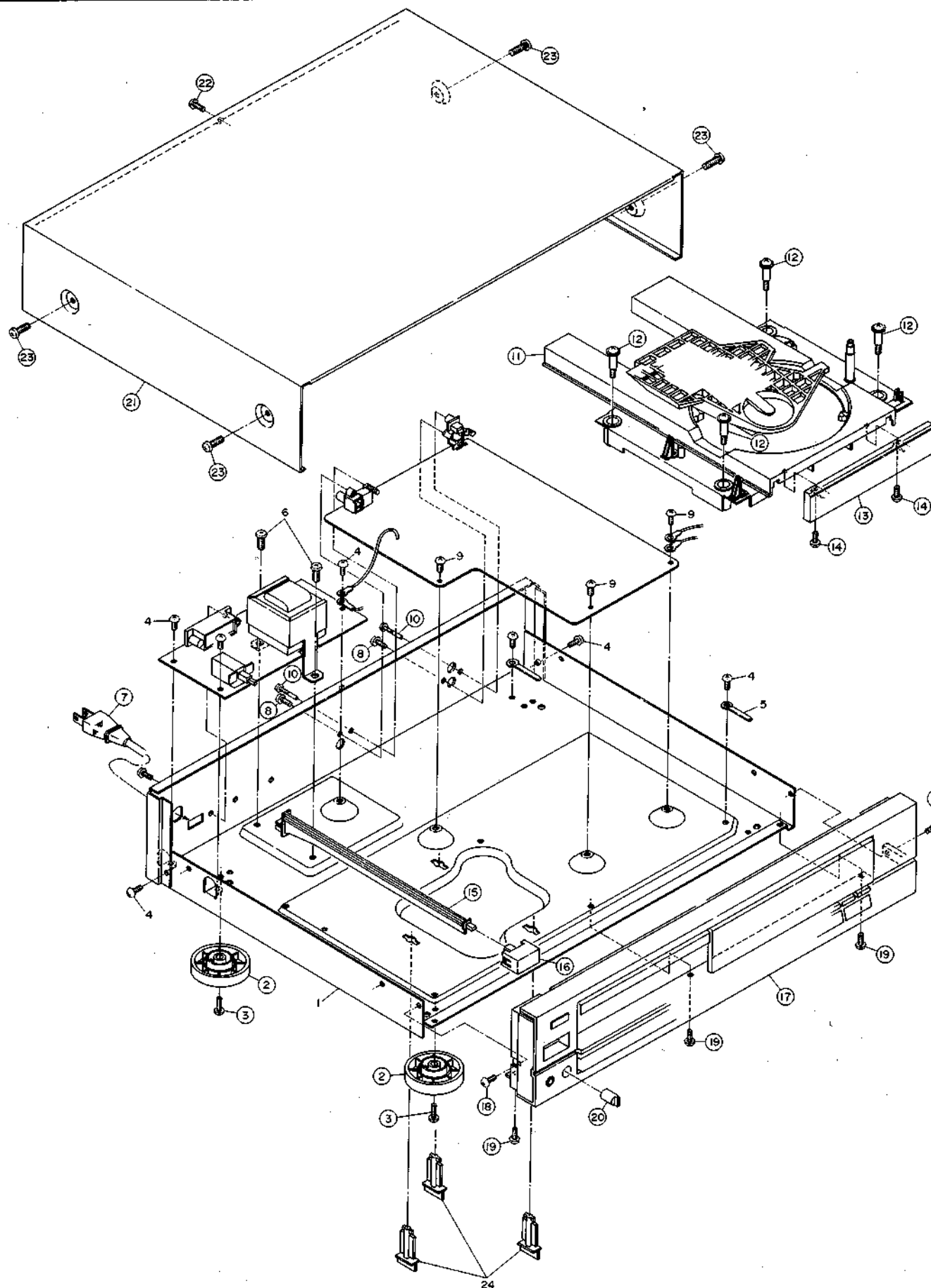

9. FINAL ASSEMBLY BLOCK

Ref. No.	Part No.	Description
2	SA-379375	FOOT(N)
3	ZS-352133	ST BR30X10STL CMT
4	ZS-320906	ST BR30X06STL CMT
5	EZ-323793	CORD RETAINER 32X41
6	ZS-313796	ST BD40X06STL CMT
7A	*EW-363658	AC CORD 200 0129AVFF B100 A U/ [U]
7B	*EW-363621	AC CORD200 0238 SPT1 B100 A UC [C.A]
7C	*EW-363671	AC CORD 200 0364 LCFL B100 A E [E.V]
7D	*EW-363683	AC CORD 200 LCFL B100 A B [B]
7E	*EW-363697	AC CORD 200 0436 LCFL B100 A S [S]
8	ZS-350934	PT BR30X08STL BNI
9	ZS-342001	ST BR30X06STL NI3
10	ZS-308673	T2PAN30X20STL NI3 GUIDE
11	BB-P2036A060A	MECHA BLK CD-32
12	ZS-378163	SCREW GRADUATED
13-B	SP-378153	PANRL TRAY B
13-G	SP-379922J	PANEL TRAY G
14	ZS-351204	PT BR30X06STL BNI
15	MZ-378144	JOINT POW
16-B	SK-373236B	KNOB POWER-B
16-G	SK-373236A	KNOB POWER-G
17-B	BD-P2036A020A	PANEL FRONT BLK CD-32-B
17-G	BD-P2036A020B	PANEL FRONT BLK CD-32-G
18	ZS-354403	ST BR30X08STL BNI
19	ZS-365759	CT BR30X08STL BZN PROJECTION
20-B	SK-377733	KNOB VOL B
20-G	SK-379924J	KNOB VOL G
21-B	SP-378157	COVER UPPER B
21-G	SP-379925J	COVER UPPER G
22	ZS-365759	CT BR30X08STL BZN PROJECTION
23-B	ZS-341960	ST BD40X06STL BNI
23-G	ZS-341959	ST BD40X06STL NI3
25	MZ-379921J	HOLDER PANEL TRAY

10. ACESARY

Ref. No.	Part No.	Description
1	EW-344151	CORD RR-61A PINX2-PINX2
2	AX-380250J	REMOCON RC-C32 WIRELESS T

INDEX

Part No.	Ref. No.	Part No.	Ref. No.	Part No.	Ref. No.	Part No.	Ref. No.
AX-380250J	2	EI-367271	33	ET-353899	TR21		
BA-P2036A030A	1A	EI-367271	IC1	ET-354897	45		
BA-P2036A030B	1B	EI-368608	24	ET-354897	TR22		
BB-P2036A060A	1	EI-368608	IC1	ET-360067	50		
BB-P2036A060A	11	EI-368609	25	ET-360067	TR8		
BD-P2036A020A	17-B	EI-368609	IC2	ET-360067	TR17		
BD-P2036A020B	17-G	EI-368610	26	ET-360067	TR19		
BM-B328441X1	2	EI-368610	IC3	ET-360067	TR28		
BM-B328441X1	9	EI-368611	28	ET-360067	TR26		
BM-B371552X1	3	EI-368611	IC4	ET-378524J	51		
BM-B371552X1	11	EI-368612	30	ET-378524J	TR23		
BM-B372237X1	4	EI-368612	IC8	EV-358829	VR1		
BM-B372237X1	6	EI-371572	34	EV-358829	VR2		
BO-368598	5	EI-371572	IC12	EV-358829	VR3		
BO-368598	2	EI-374176	38	EV-358829	VR4		
BT-368261	10	EI-374176	X1	EV-371279	VR5		
BT-368261	T1	EI-377246	35	EV-378175	54		
BT-378168	9	EI-377246	IC13	EV-378175	VR6		
BT-378168	T1A	EI-379865J	27	EW-344151	1		
BT-378169	6	EI-379865J	IC5	EW-363821	7B		
BT-378169	T1B	EJ-337424	P7	EW-363858	7A		
BT-378170	8	EJ-376482	P11	EW-363871	7C		
BT-378170	T1C	EJ-380297J	P15	EW-363883	7D		
BT-378171	7	EM-374177	37	EW-363897	7E		
BT-378171	T1D	EM-374177	FL1	EW-368599	3		
EC-338496	C6	EO-338409	38	EW-368600	4		
ED-305706	16	EO-338409	FL1	EZ-323793	5		
ED-305706	D8	EO-345902	L1	MB-368350	8		
ED-330622	13	EO-345913	L1	MB-368590	55		
ED-330622	D204	EO-345913	L2	MB-368590	17		
ED-330622	D1	ER-328278	39	MB-377975	24		
ED-330622	D2	ER-328278	R42	MB-378827J	25		
ED-330622	D3	ES-349464	43	MR-374137	16		
ED-330622	D4	ES-349464	VS1	MS-368348	5		
ED-330622	D5	ES-355842	42	MZ-368347	20		
ED-330622	D6	ES-355842	13	MZ-368349	57		
ED-330622	D7	ES-368603	40	MZ-368349	10		
ED-330622	D8	ES-368603	12	MZ-374138	58		
ED-330622	D9	ES-371104	41	MZ-374138	18		
ED-330622	D12	ES-371104	SW1	MZ-378144	15		
ED-344280	12	ES-373381	44	MZ-378828J	27		
ED-344280	D3	ES-373381	TS1	MZ-379921J	25		
ED-344280	D8	ES-373381	TS2	SA-379375	2		
ED-344280	D9	ES-373381	TS3	SC-B374139	23		
ED-344280	D11	ES-373381	TS4	SK-373236A	16-G		
ED-344280	D12	ES-373381	TS5	SK-373236B	16-B		
ED-344280	D201	ES-373381	TS6	SK-377733	20-B		
ED-344280	D202	ES-373381	TS7	SK-379924J	20-G		
ED-344280	D203	ES-373381	TS8	SP-378153	13-B		
ED-348529	15	ES-373381	TS9	SP-378157	21-B		
ED-348529	D15	ES-373381	TS10	SP-379922J	13-G		
ED-348609	17	ES-373381	TS11	SP-379925J	21-G		
ED-348609	D11	ES-373381	TS12	SZ-374136J1	21		
ED-348620	14	ES-373381	TS13	ZG-368591	22		
ED-348620	D10	ES-373381	TS14	ZS-308673	10		
ED-360409	11	ES-373381	TS15	ZS-313796	6		
ED-360409	D1	ES-373381	TS16	ZS-320906	4		

ABBREVIATIONS (COMPACT DISC)

ABBREVIATION	EXPLANATION	ABBREVIATION	EXPLANATION
A-D	Analog to Digital (Convertor)	Mb	Mega Bits
ADC	Analog to Digital (Convertor)	MDA	Motor Drive Amplifier
BCD	Binary Code Decimal	MFM	Modified Frequency Modulation
BPI	Bits per Inch	MM	Mono-stable Multivibrator
CD	Compact Disc	M ² FM	Modified Modified Frequency Modulation
CIRC	Cross Interleaving & Reed Solomon Coding	MOD2	Modulo 2 (Addition)
CLV	Constant Linear Velocity	MP	Microprocessor
CP	Clock Pulses	MSB	Most Significant Bit
CRCC	Cyclic Redundancy Check Codes	NA	Numerical Aperture
D Level	Decision Level	NRZ	Non Return to Zero
D-A	Digital to Analog (Convertor)	NRZ-1	Non Return to Zero Inverted
DAC	Digital to Analog (Convertor)	P	Parity Data
DAD	Digital Audio Disc	PAM	Pulse Amplitude Modulation
DEM	Dynamic Element Matching	PCM	Pulse Code Modulation
DPD	Differential Phase Detection	PD	Phase Detector
DSV	Digital Sum Value	PE	Phase Encode
EFM	Eight to fourteen Modulation	PLL	Phase Locked Loop
EX-OR	EXclusive OR	PNM	Pulse Number Modulation
FCI	Flux Chnnges per Inch	PPM	Pulse Phase Modulation
FIR	Finite Impulse Response	PWM	Pulse Width Modulation
FP	Front Pulse	Q	Parity Data
FPG	Front Pulse Gate	R,R ₁ ,R ₂ , etc.	Data for Right Channel
f	Frequency of Sampling	RAM	Random Access Memory
GF	Galois Field	RPG	Rear Pulse Gate
H&V (Parity)	Horizontal & Vertical	SCOOP	Self Coupled Optical Pick-up
IIR	Infinite Impulse Response	S&H	Sample & Hold
kb	Kilo Bits	S/N	Signal to Noise Ratio
L,L ₁ ,L ₂ , etc.	Data for Left Channel	SSG	Standard Signal Generator
LPF	Low Pass Filter	SYS CON	SYStem CONtrol
LSB	Least Significant Bit		