

AKAI SERVICE MANUAL

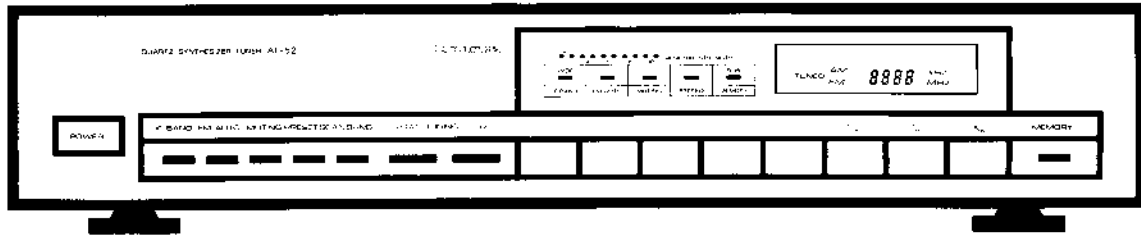

QUARTZ SYNTHESIZER TUNER

MODEL AT-52/L

SPECIFICATIONS

FM Tuner section	AM tuner section (MW & LW for AT-52L)			
Tuning frequency range	87.5 MHz to 108.0 MHz	AM tuner Section (MW for AT-52L)	LW tuner Section (for AT-52L)	
Usable sensitivity	11.2 dBf	Tuning frequency range	531kHz to 1,602 kHz	160 kHz to 340 kHz
Quieting sensitivity (S/N = 50 dB)	16.2 dBf (Mono)/37.2 dBf (Stereo)	Usable sensitivity (Loop antenna)	400 μ V/m	800 μ V/m
Capture ratio	1.5 dB	Selectivity	50 dB	50 dB
Selectivity		Image rejection	40 dB	40 dB
Narrow	90 dB	IF rejection	30 dB	30 dB
Wide	60 dB	S/N	40 dB	35 dB
Image rejection	78 dB	T.H.D.	1.0%	2.0%
IF rejection ratio	85 dB	Output level		
Spurious rejection	90 dB	FM	700 mV (100% Mod.)	
AM suppression	60 dB	AM (MW for AT-52L) ...	250 mV (30% mod.)	
Sub carrier suppression	60 dB	Power requirements	220V, 50 Hz for Europe	
S/N (IHF)	75 dB (Mono)/65 dB (Stereo)	Except UK	240V, 50 Hz for UK	
T.H.D. (1 kHz)		110 - 120V/220 - 240V,	50/60 Hz convertible for other countries	
Narrow	0.15% (Mono)/0.35% (Stereo)	Dimensions	425(W) \times 85(H) \times 335(D) mm	
Wide	0.08% (Mono)/0.20% (Stereo)	(16.7 \times 3.4 \times 13.2 inches)		
Stereo separation (1 kHz)		Weight	4.0 kg (8.8 lbs)	
Narrow	45 dB			
Wide	50 dB			
Frequency response	30 Hz to 15 kHz \pm 1.0 dB			

* For improvement purposes, specifications and design are subject to change without notice.

★ SAFETY INSTRUCTIONS

PRECAUTIONS DURING SERVICING

1. Parts identified by the Δ symbol are critical for safety. Replace only with parts number specified.
2. In addition to safety, other parts and assemblies are specified for conformance with such regulations as those applying to spurious radiation. These must also be replaced only with specified replacements.
Examples: RF converters, tuner units, antenna selector switches, RF cables, noise blocking capacitors, noise blocking filters, etc.
3. Use specified internal wiring. Note especially:
 - 1) Wires covered with PVC tubing
 - 2) Double insulated wires
 - 3) High voltage leads
4. Use specified insulating materials for hazardous live parts. Note especially:
 - 1) Insulation Tape
 - 2) PVC tubing
 - 3) Spacers (Insulating Barriers)
 - 4) Insulation sheets for transistors
 - 5) Plastic screws for fixing microswitch (especially in turntable)
5. When replacing AC primary side components (transformers, power cords, noise blocking capacitors, etc.), wrap ends of wires securely about the terminals before soldering.

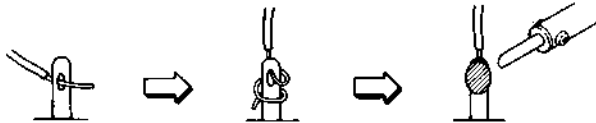

6. Observe that wires do not contact heat producing parts (heatsinks, oxide metal film resistors, fusible resistors, etc.).

7. Check that replaced wires do not contact sharp edged or pointed parts.
8. Also check areas surrounding repaired locations.
9. Use care that foreign objects (screws, solder droplets, etc.) do not remain inside the set.

SAFETY CHECK AFTER SERVICING

Confirm the specified insulation resistance between power cord plug prongs and externally exposed parts of the set is greater than 10 M ohms, but for equipment with external antenna terminals (tuner, receiver, etc.) and is intended for [C] or [A], specified insulation resistance should be head-phone jacks, line-in-out jacks, etc. more than 2.2 M ohms (ground terminals, microphone jacks).

PRECAUTION FOR THE LITHIUM BATTERY

The lithium battery may explode when heated excessively. [OBSERVE THE FOLLOWING WHEN REPLACING]

- Replace with the same make and type only.
- Use soldering iron in "recommended way" only.
- Place battery in correct polarity.
- Do not short the terminals.
- Do not recharge battery.
- Do not dispose of battery in fire.

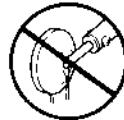

[DANGER]



[RECOMMENDED WAY]

★ INFORMATION

SYMBOL FOR PRIMARY DESTINATION

Alphabet indicates the destination of the units as listed below.

Symbols	Principal Destinations
[A]	USA
[B]	UK
[C]	Canada
[E]	Europe (except UK)
[J]	Japan
[S]	Australia
[V]	W. Germany only
[U]	Universal Area
[Y*]	Custom version

VOLTAGE CONVERSION ([U] Model only)

Before connecting the power cord, SET the VOLTAGE SELECTOR located on the rear panel with a screwdriver so that the correct voltage is indicated.

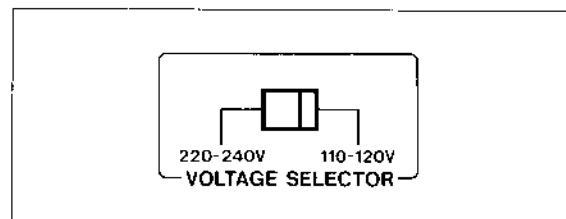

ABBREVIATIONS (TUNER)

Abbreviation	Explanation	Abbreviation	Explanation
AFC	Auto Frequency Control	MEMO	MEMOry
AGC	Auto Gain Control	MI-COM	Micro-COMputer
ALC	Auto Level Control	MIN	MINimum
AM	Amplitude Modulation	MIX	MIXing
AMP	AMPLifier	MPX	Multi PleX
ANT	ANTenna	MW	Medium Wave (frequency)
BATT	BATTery	NC	No Connection
BLK	BLock	NFB	Negative Feed Back
BUFF	BUFFer	OSC	OSCillator
COMP	COMParator	PCB	Printed Circuit Board
DET	DETECT (DETECTor)	PLL	Phase Locked Loop
FLD		Q.D	Quadrature Detector
FM	Frequency Modulation	Rch	Right channel
FREQ	FREQUENCY	REF	REFerence
GND	GrouND	REG	REGulator
H	High	RF	Radio Frequency
HPF	High Pass Filter	SEG	SEGment
IF	Intermediate Frequency	SELE	SELEctor
IHF	Institut of High Fidelity	SENS	SENSitivity
IND	INDicator	SIG	SIGnal
I/O	In/Out	S/N	Signal to Noise Ratio
JW	Jumper Wire	SSG	Standard Signal Generator
L	Low	STD	STanDard
LCD	Liquid Crystal Display	SW	SWitch : Short Wave (frequency)
Lch	Left channel	THD	Total Harmonic Distortion
LED	Light Emitting Diode	TP	Test Point
LPF	Low Pass Filter	VCO	Voltage Controlled Oscillator
LW	Long Wave (Frequency)	VR	Variable Resistor
		X'TAL	Crystal

I. CONTROLS

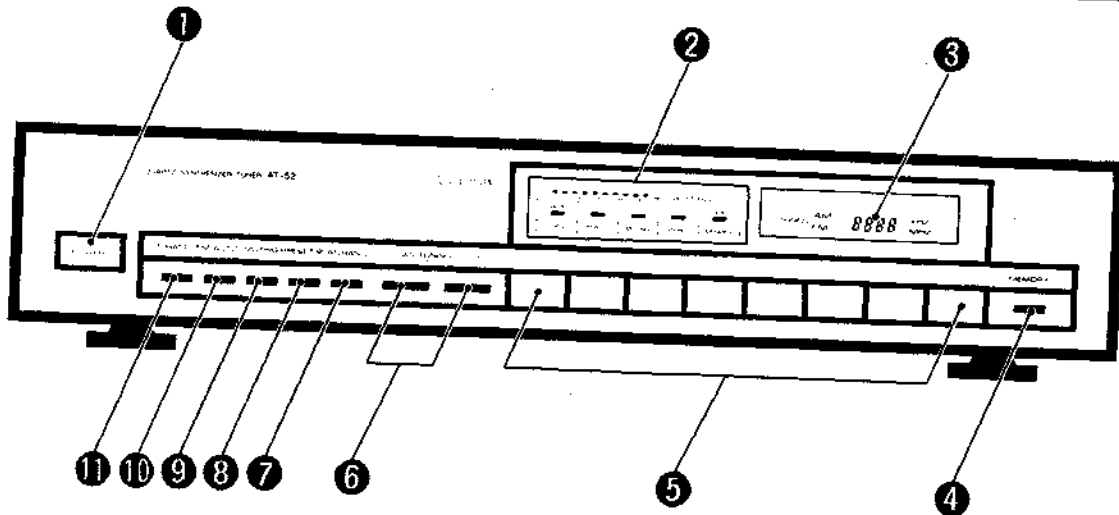

- 1 POWER Switch**
To turn the power on and off.
- 2 LED (Light Emitting Diode) Indicators**
Tells you which mode the tuner is in.
- 3 FL (Fluorescent) Display**
Shows tuning information.
- 4 MEMORY button**
To memorize preset stations. Press the button once to preset station numbers 1 to 8. Press the button twice to preset station numbers 9 to 16.
- 5 Preset Station Buttons (1 to 16)**
To memorize preset stations and tune in memorized stations.
- 6 TUNING Control buttons (UP/DOWN)**
To tune in a station manually.
- 7 BAND Button**
To select the band.
- 8 PRESET SCAN Button**
To select the preset scanning mode of the tuner.
- 9 MUTING button**
To cut interstation noise during FM station tuning.
- 10 FM AUTO button**
To select FM AUTO or monoaural mode.
- 11 IF BAND Select button**
To select the wide or narrow FM IF (Intermediate Frequency) band.

LED Indicators

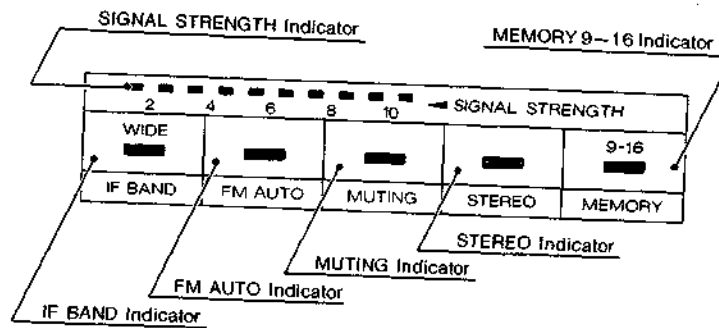

SIGNAL STRENGTH Indicators
Tells you the strength of the tuned in station's signal.

WIDE Indicator
Tells you the IF band of the tuner is set to WIDE.

MUTING Indicator
Tells you the muting system is engaged.

STEREO Indicator
Tells you the received FM broadcast program is in the stereo mode.

MEMORY 9-16 Indicator
Tells you the preset station number is between 9 and 16.

II. DISASSEMBLY

In case of trouble, etc, necessitating dismantling, please dismantle in the order shown in the photographs.
Reassemble in reverse order.

1. REMOVAL OF UPPER COVER

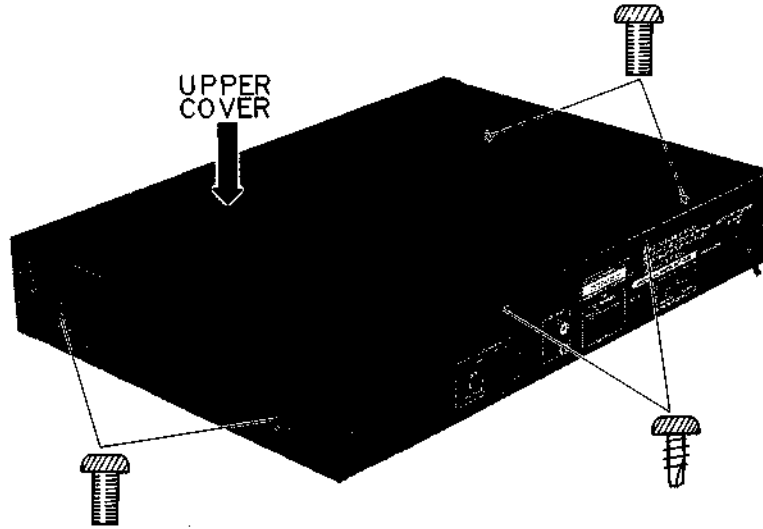

2. REMOVAL OF FRONT PANEL

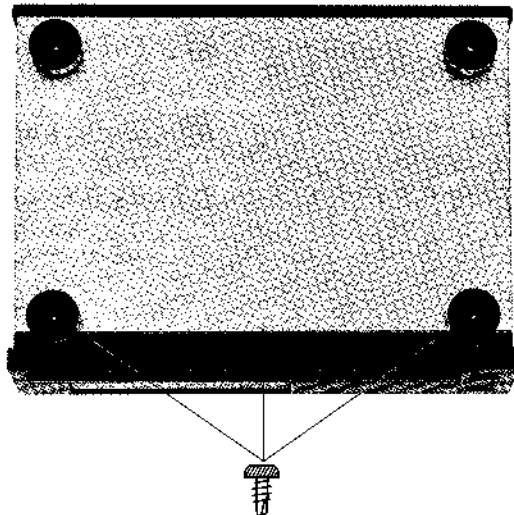

3.

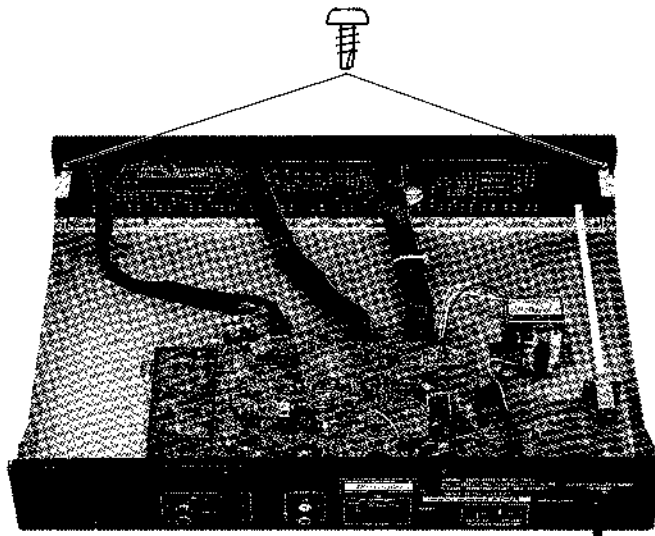

IV. ADJUSTMENT

4-1. INSTRUMENT CONNECTIONS

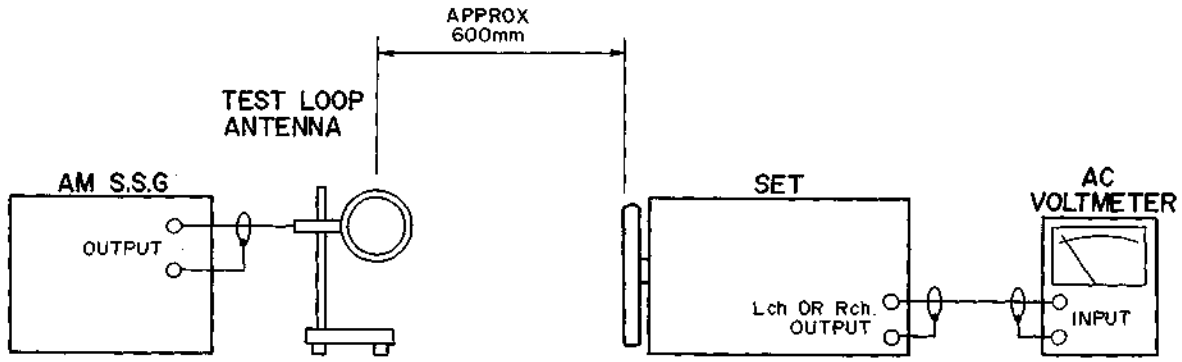

Fig. 4-1 Instrument Connection of AM Adjustment

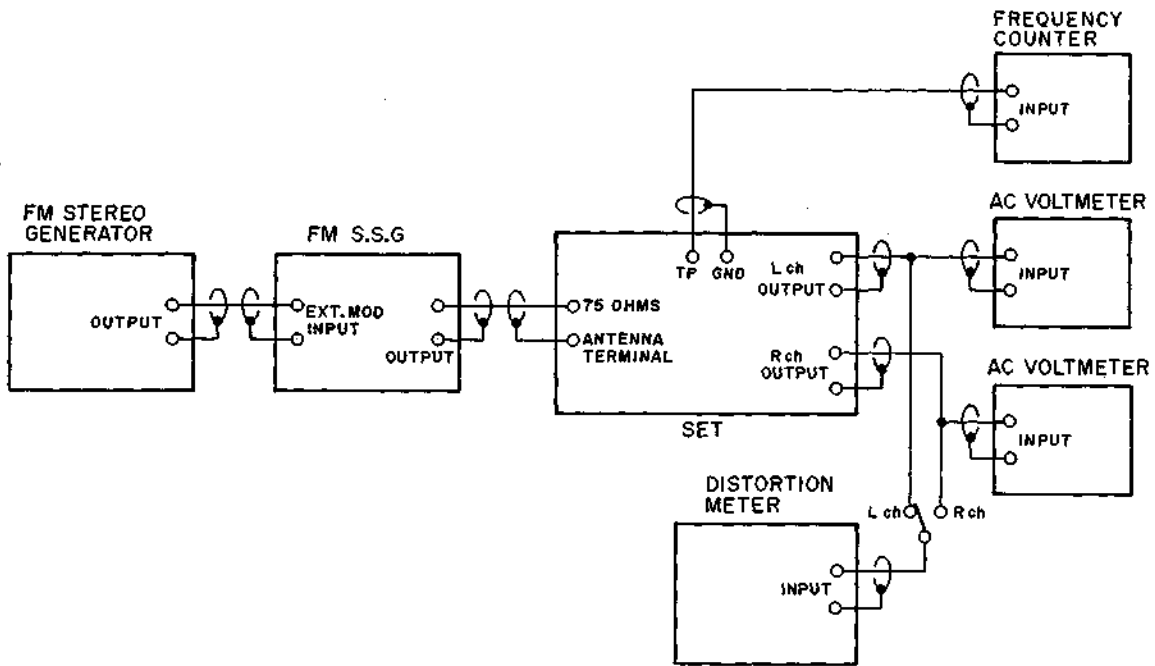

Fig. 4-2 Instrument Connection of FM Adjustment

4-2. HOW TO CALL THE PRESET FREQUENCY FOR THE ADJUSTMENT

Press the RESET SW on the REAR PANEL. The internal frequency preset memory is set as below.

	CH1	CH2	CH3	CH4	CH5	CH6	CH7	CH8
AT-52 [U] (10 kHz step)	AM 600 kHz	AM 1000 kHz	AM 1400 kHz	AM 1610 kHz	FM	FM	FM	FM
AT-52 [E] [V] (9 kHz step)	AM	AM	AM	AM	90.0 MHz	98.0 MHz	106.0 MHz	108.0 MHz
AT-52L [E] [B] (9 kHz step)	603 kHz	999 kHz	1404 kHz	1602 kHz				

	CH9	CH10	CH11	CH12	CH13	CH14	CH15	CH16
FM	FM	FM	FM	FM	FM	FM	FM	FM
87.5 MHz	87.5 MHz	87.5 MHz	87.5 MHz	87.5 MHz	87.5 MHz	87.5 MHz	87.5 MHz	87.5 MHz
	AM 160 kHz	AM 200 kHz	AM 300 kHz					

4-3. ADJUSTMENT

NOTE: 1. Set the SSG to 1 KHz, 75 KHz deviation for [U] model, 1 KHz, 40 KHz deviation for [B], [E] or [V] model.
 2. Set the MUTE SW to OFF and IF Band SW to WIDE without notice.
 3. Confirm that the Sensitivity margin between Low and High range sensitivities is within 3 dB, otherwise readjust Low and High range sensitivity.

STEP	ADJUSTMENT ITEM
1.	SSG FREQ. & OUTPUT LEVEL
2.	SET Tuning FREQ.
3.	Test Point & ADJ. Part
4.	Result & Remarks

Adjustment Part
 Test Point

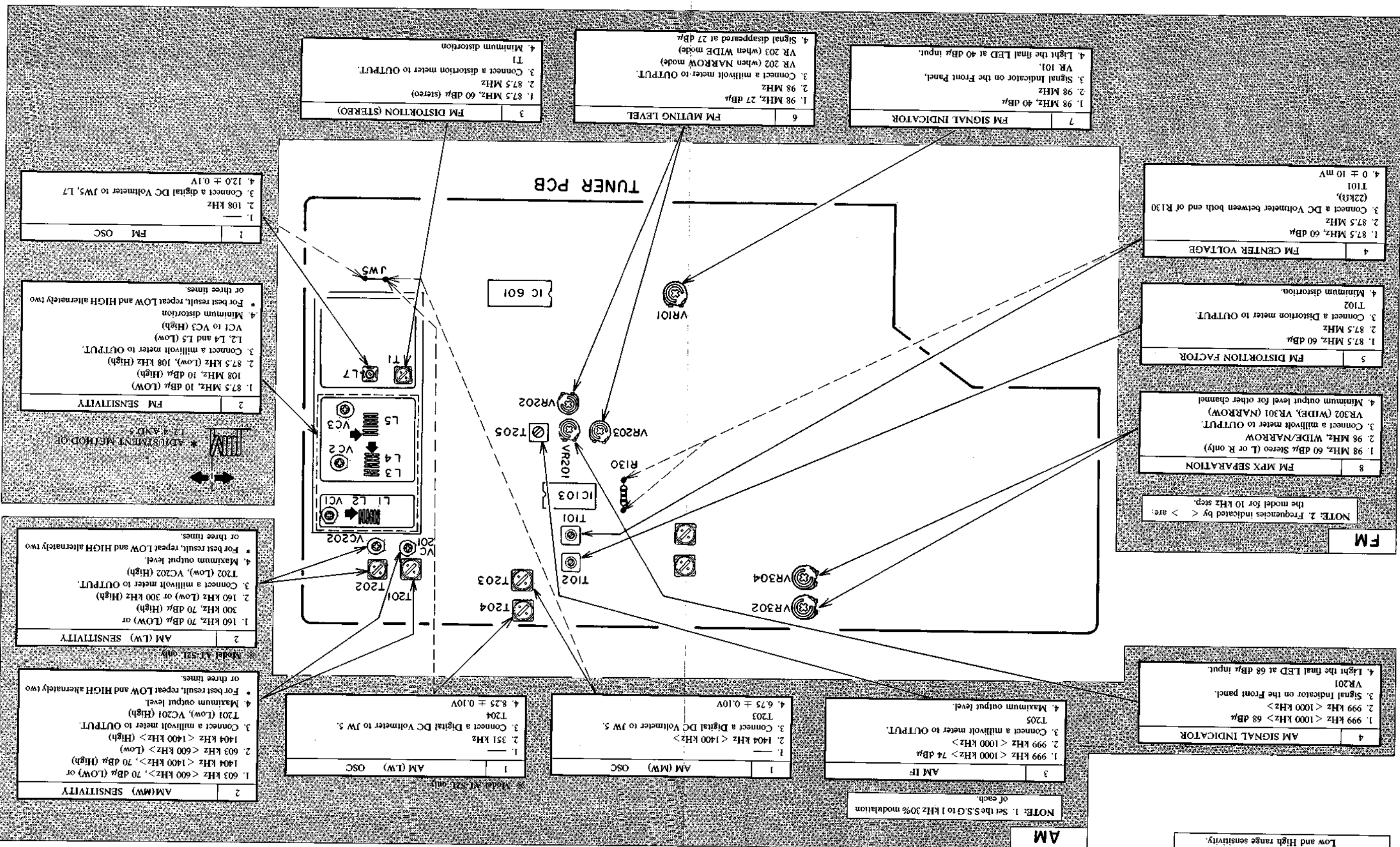

AM

NOTE: 1. Set the SSG to 1 KHz 30% modulation of each.

1.	999 KHz < 1000 KHz > 74 dBμ
2.	999 KHz < 1000 KHz >
3.	Connect a millivolt meter to OUTPUT.
4.	Maximum output level.

AM IF

1.	1404 KHz < 1400 KHz >
2.	351 KHz
3.	Connect a Digital DC Voltmeter to JW 5.
4.	8.25 ± 0.10V

AM (MW) OSC

1.	603 KHz < 600 KHz >, 70 dBμ (LOW) or 1404 KHz < 1400 KHz >, 70 dBμ (High)
2.	603 KHz < 600 KHz > (Low)
3.	Connect a millivolt meter to OUTPUT.
4.	Maximum output level.

AM (MW) SENSITIVITY

Model A1-S2L only

1.	160 KHz, 70 dBμ (Low) or 300 KHz, 70 dBμ (High)
2.	160 KHz (Low) or 300 KHz (High)
3.	Connect a millivolt meter to OUTPUT.
4.	Maximum output level.

AM (LW) SENSITIVITY

Model A1-S2L only

ADJUSTMENT METHOD OF L2, L4 AND L5

1.	87.5 MHz, 10 dBμ (LOW)
2.	87.5 MHz (Low), 108 KHz (High)
3.	Connect a millivolt meter to OUTPUT.
4.	Minimum distortion

FM SENSITIVITY

ADJUSTMENT METHOD OF L7 AND L7

1.	87.5 MHz, 10 dBμ (LOW)
2.	87.5 MHz (Low), 108 KHz (High)
3.	Connect a millivolt meter to OUTPUT.
4.	Minimum distortion

FM SENSITIVITY

1.	FM OSC
2.	108 KHz
3.	Connect a digital DC Voltmeter to JW5, L7
4.	12.0 ± 0.1V

1.	87.5 MHz, 60 dBμ (stereo)
2.	87.5 MHz
3.	Connect a distortion meter to OUTPUT.
4.	Minimum distortion

FM DISTORTION (STEREO)

1.	98 MHz, 27 dBμ
2.	98 MHz
3.	Connect a millivolt meter to OUTPUT.
4.	Signal disappeared at 27 dBμ

FM MUTE LEVEL

1.	98 MHz, 40 dBμ
2.	98 MHz, 40 dBμ
3.	Signal Indicator on the Front Panel.
4.	Light the final LED at 40 dBμ input.

FM SIGNAL INDICATOR

1.	87.5 MHz, 60 dBμ
2.	87.5 MHz
3.	Connect a Distortion meter to OUTPUT.
4.	Minimum distortion.

FM DISTORTION FACTOR

1.	98 MHz, 60 dBμ Stereo (L or R only)
2.	98 MHz, WIDE/NARROW
3.	Connect a millivolt meter to OUTPUT.
4.	Minimum output level for other channel.

FM MPX SEPARATION

1.	87.5 MHz, 60 dBμ
2.	87.5 MHz
3.	Connect a DC Voltmeter between both end of R130
4.	0 ± 10 mV

FM CENTER VOLTAGE

1.	98 MHz, 60 dBμ Stereo (L or R only)
2.	98 MHz, WIDE/NARROW
3.	Connect a millivolt meter to OUTPUT.
4.	Minimum output level for other channel.

FM MPX SEPARATION

NOTE: 2. Frequencies indicated by < > are: the model for 10 KHz step.

ATTENTION

- When placing an order for parts, be sure to list Part No., Model No. and the description of each part. Otherwise, the non-delivery of the part or the delivery of a wrong part may result.
- Please make sure that Part No. is correct when ordering. If not, a part different from the one you ordered may be delivered.
- Since the parts shown in Parts List of Preliminary Service Manual may have been the subject of changes, please use this Parts List for all future reference.

HOW TO USE THIS PARTS LIST

- This Parts List lists those parts which are considered necessary for repairs. Other common parts, such as resistors and capacitors, are listed in the "Common List for Service Parts" from which these parts should be selected and stocked.
- The Recommended Spare Parts List shows those parts in the Parts List which are considered particularly important for service.
- Parts not shown in the Parts List and "Common List for Service Parts" will not in principle be supplied.
- How to read the Parts List.

2. HEAD BASE BLOCK

REF. NO.	PART NO.	DESCRIPTION
2-1X	BH-T2023A20A	HEAD BASE BLOCK
2-2	HP-H2206A010A	HEAD R/P PR4-8FU C
2-3	ZS-477876	PAN20x03STL CMT
2-4	ZS-536488	BID20x08STL CMT
2-5	ZG-402895	SP CS ANGLE ADJUST

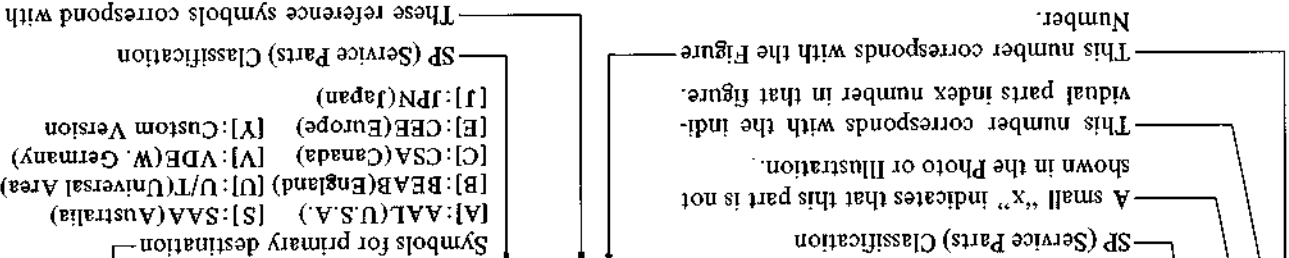

The available PC Board Blocks are listed separately. When Part No. is known, Parts Index at end of Parts List can be used to locate where that part is shown in Parts List by its Reference No. listed at right of Part No.

WARNING

△ (*) INDICATES SAFETY CRITICAL COMPONENTS. FOR CONTINUED SAFETY, REPLACEMENT PARTS MUST BE IDENTICAL TO ORIGINAL PARTS.

△ (*) IL INDIQUE LES COMPOSANTS CRITIQUES DE SECURITE. POUR MAINTENIR LE DEGRE DE SECURITE DE L'APPAREIL, NE REMPLACER QUE DES PIECES RECOMMANDEES PAR LE FABRICANT.

1. RECOMMENDED SPARE PARTS

Ref. No.	Part No.	Description
1	*BT-721687J	TRANS POWER AT-52 IU
2	*BT-721685J	TRANS POWER AT-52/L (B)
3	*BT-721684J	TRANS POWER AT-52/L(E,V)
4	ED-721694J	D LED MP6578X GRN
5	ED-723951J	D LED PR6524S RED
6	*ED-345555	D SILICON DBB10C 200/1.0A
7	*ED-357754	D SILICON DS135D 200/1.0A
8	ED-301911	D SILICON H DS448
9	ED-344280	D SILICON H GMA-01-FY2 F05
10	ED-371782	D SILICON H 1S2186
11	ED-336832-A	D VARIATOR SVC211SPA A,B,C,D,E
12	ED-353692-A	D VARIATOR SVC321SPA C,D DBL
13	ED-712926	D ZENER H GZA12 X
14	*ED-715992	D ZENER H GZA15 Y
15	ED-721696J	D ZENER H GZA22 X
16	ED-721695J	D ZENER H GZA22 X
17	ED-712000	D ZENER H GZA5.1 X
18	ED-708046	D ZENER H GZA5.1 Y
19	ED-712928	D ZENER H GZA5.6 X
20	ED-712927	D ZENER H GZA9.1 X
21	*EF-359342	FUSE BET T 250V 400MA (B,E,V)
22	*EF-309933	FUSE TSC A 250V 200MA (U)
23	EH-344434	FILTER CE BFU450CAN 0.450MHZ
24	EH-315407	FILTER CE SFE10.7MMKA 10.7MHZ
25	EH-706132	FILTER CE SFE10.7MMKA 10.7MHZ
26	EH-721705J	FILTER LP 42B-1083-03
27	EH-721706J	FILTER LP 42B-1083-03
28	EH-358818	IC A3048-714 AKAI COSTOM
29	EH-337964	IC BA401
30	EH-356457	IC BU4013B
31	EH-719341	IC LA1266
32	EH-349963	IC LA410
33	EH-345551	IC LB1403
34	EH-354951	IC LM7000N
35	EH-348409	O SC CE CSB400P 0.400000MHZ
36	EH-349970	O SC CE CSB456F11 0.456MHZ
37	EH-344222	O SC X TAL HC-18/U 7.200MHZ
38	EM-353670	IND FL 8-BT-29ZK CHARACTER
39	*ES-337902	SW PUSH SLDIF 01-1 (POWER)
40	*ES-349464	SW SLIDE 00120319 01-2
41	ES-344439	SW SLIDE 00420451 2-04-02 (U) (VOLTA GE SELECTOR)
42	ES-349367	SW TACT SKHAKK003A
43	ES-721688J	SW TACT SKHLD (RESET)
44	ET-363326	TR FET 2SK161 GR
45	ET-34449	TR FET 2SK161 O,Y
46	ET-337759	TR FET 2SK246 GR
47	ET-337743	TR FET 3SK107 EF AKAI
48	ET-353899	TR ZSA1317 S.T.U
49	ET-349718	TR ZSA1392 S.T
50	*ET-336997	TR ZSB808-V GH
51	ET-336869	TR ZSC2999 C,D
52	ET-353898	TR ZSC3330 F05
53	ET-349081	TR ZSC3383 S.T
54	ET-349592	TR ZSC3400 F05
55	ET-328265	TR ZSC930 F
56	ET-347961	TR ZSD1012-V G F05
57	*ET-349459	TR ZSD1406 O,Y GR
58	*EZ-358816	BATTERY LITHIUM BR2032-1HF

2. P.C BOARD BLOCK

Ref. No.	Part No.	Description
1A	BA-721701J	PC TUNER BLK AT-52(U)
1B	BA-721702J	PC TUNER BLK AT-52(E,B)
1C	BA-721700J	PC TUNER BLK AT-52(V)
1D	BA-721699J	PC TUNER BLK AT-52(E,B)
2	BA-722674J	PC CONTROL BLK AT-52 (E,B)
C801	*EC-320548	C CE V F 103Z 250AC (B,E,V)
C813	*EC-338496	C CE V F 472P 400AC (B,E,V)
C814	*EC-320548	C CE V F 103Z 250AC (B,E,V)

3. TUNER P.C BOARD

Ref. No.	Part No.	Description
D1	ED-336832-A	VARIATOR SVC211SPA A,B,C,D,E (U)
D2	ED-336832-A	VARIATOR SVC211SPA A,B,C,D,E
D3	ED-336832-A	VARIATOR SVC211SPA A,B,C,D,E
D4	ED-336832-A	VARIATOR SVC211SPA A,B,C,D,E
D101	ED-344280	D SILICON H GMA-01-FY2 F05
D102	ED-344280	D SILICON H GMA-01-FY2 F05
D103	ED-344280	D SILICON H GMA-01-FY2 F05
D104	ED-344280	D SILICON H GMA-01-FY2 F05
D105	ED-344280	D SILICON H GMA-01-FY2 F05
D106	ED-344280	D SILICON H GMA-01-FY2 F05
D107	ED-344280	D SILICON H GMA-01-FY2 F05
D108	ED-301911	D SILICON H DS448
D109	ED-344280	D SILICON H GMA-01-FY2 F05
D110	ED-344280	D SILICON H GMA-01-FY2 F05
D111	ED-344280	D SILICON H GMA-01-FY2 F05
D201	ED-371782	D SILICON H 1S2186
D202	ED-353692-A	VARIATOR SVC321SPA C,D DBL
D203	ED-353692-A	VARIATOR SVC321SPA C,D DBL
D204	ED-344280	D SILICON H GMA-01-FY2 F05
D205	ED-344280	D SILICON H GMA-01-FY2 F05
D301	ED-301911	D SILICON H DS448
D601	ED-344280	D SILICON H GMA-01-FY2 F05
D602	ED-712927	D ZENER H GZA9.1 X
D603	ED-344280	D SILICON H GMA-01-FY2 F05
D801	ED-344280	D SILICON H GMA-01-FY2 F05
D802	ED-344280	D SILICON H GMA-01-FY2 F05
D803	*ED-357754	D SILICON DS135D 200/1.0A
D804	*ED-345555	D SILICON DBB10C 200/1.0A
D805	ED-712926	D ZENER H GZA12 X
D806	ED-721695J	D ZENER H GZA22 X
D807	ED-712928	D ZENER H GZA5.6 X
D808	*ED-715992	D ZENER H GZA15 Y
D809	ED-715992	D ZENER H GZA15 Y
D810	ED-712000	D ZENER H GZA5.1 X
D811	ED-344280	D SILICON H GMA-01-FY2 F05
D812	ED-708046	D ZENER H GZA5.1 Y
D813	ED-344280	D SILICON H GMA-01-FY2 F05
D814	ED-344280	D SILICON H GMA-01-FY2 F05
D815	ED-344280	D SILICON H GMA-01-FY2 F05
FL101	EH-315407	FILTER CE SFE10.7MMKA 10.7MHZ
FL102	EH-315407	FILTER CE SFE10.7MMKA 10.7MHZ
FL103	EH-315407	FILTER CE SFE10.7MMKA 10.7MHZ
FL104	EH-315407	FILTER CE SFE10.7MMKA 10.7MHZ
FL201	EH-706132	FILTER CE SFE10.7MMKA 10.7MHZ
FL202	EH-344434	FILTER CE BFU450CAN 0.450MHZ
FL301	EH-721705J	FILTER LP 42B-1083-03
FL302	EH-721705J	FILTER LP 42B-1083-03
IC101	EH-337964	IC BA401
IC102	EH-337964	IC BA401
IC103	EH-337964	IC BA401
IC104	EH-337964	IC BA401
IC105	EH-337964	IC BA401
IC106	EH-337964	IC BA401
IC107	EH-337964	IC BA401
IC108	EH-337964	IC BA401
IC109	EH-337964	IC BA401
IC110	EH-337964	IC BA401
IC111	EH-337964	IC BA401
IC112	EH-337964	IC BA401
IC113	EH-337964	IC BA401
IC114	EH-337964	IC BA401
IC115	EH-337964	IC BA401
IC116	EH-337964	IC BA401
IC117	EH-337964	IC BA401
IC118	EH-337964	IC BA401
IC119	EH-337964	IC BA401
IC120	EH-337964	IC BA401
IC121	EH-337964	IC BA401
IC122	EH-337964	IC BA401
IC123	EH-337964	IC BA401
IC124	EH-337964	IC BA401
IC125	EH-337964	IC BA401
IC126	EH-337964	IC BA401
IC127	EH-337964	IC BA401
IC128	EH-337964	IC BA401
IC129	EH-337964	IC BA401
IC130	EH-337964	IC BA401
IC131	EH-337964	IC BA401
IC132	EH-337964	IC BA401
IC133	EH-337964	IC BA401
IC134	EH-337964	IC BA401
IC135	EH-337964	IC BA401
IC136	EH-337964	IC BA401
IC137	EH-337964	IC BA401
IC138	EH-337964	IC BA401
IC139	EH-337964	IC BA401
IC140	EH-337964	IC BA401
IC141	EH-337964	IC BA401
IC142	EH-337964	IC BA401
IC143	EH-337964	IC BA401
IC144	EH-337964	IC BA401
IC145	EH-337964	IC BA401
IC146	EH-337964	IC BA401
IC147	EH-337964	IC BA401
IC148	EH-337964	IC BA401
IC149	EH-337964	IC BA401
IC150	EH-337964	IC BA401
IC151	EH-337964	IC BA401
IC152	EH-337964	IC BA401
IC153	EH-337964	IC BA401
IC154	EH-337964	IC BA401
IC155	EH-337964	IC BA401
IC156	EH-337964	IC BA401
IC157	EH-337964	IC BA401
IC158	EH-337964	IC BA401
IC159	EH-337964	IC BA401
IC160	EH-337964	IC BA401
IC161	EH-337964	IC BA401
IC162	EH-337964	IC BA401
IC163	EH-337964	IC BA401
IC164	EH-337964	IC BA401
IC165	EH-337964	IC BA401
IC166	EH-337964	IC BA401
IC167	EH-337964	IC BA401
IC168	EH-337964	IC BA401
IC169	EH-337964	IC BA401
IC170	EH-337964	IC BA401
IC171	EH-337964	IC BA401
IC172	EH-337964	IC BA401
IC173	EH-337964	IC BA401
IC174	EH-337964	IC BA401
IC175	EH-337964	IC BA401
IC176	EH-337964	IC BA401
IC177	EH-337964	IC BA401
IC178	EH-337964	IC BA401
IC179	EH-337964	IC BA401
IC180	EH-337964	IC BA401
IC181	EH-337964	IC BA401
IC182	EH-337964	IC BA401
IC183	EH-337964	IC BA401
IC184	EH-337964	IC BA401
IC185	EH-337964	IC BA401
IC186	EH-337964	IC BA401
IC187	EH-337964	IC BA401
IC188	EH-337964	IC BA401
IC189	EH-337964	IC BA401
IC190	EH-337964	IC BA401
IC191	EH-337964	IC BA401
IC192	EH-337964	IC BA401
IC193	EH-337964	IC BA401
IC194	EH-337964	IC BA401
IC195	EH-337964	IC BA401
IC196	EH-337964	IC BA401
IC197	EH-337964	IC BA401
IC198	EH-337964	IC BA401
IC199	EH-337964	IC BA401
IC200	EH-337964	IC BA401

Ref. No.	Part No.	Description
IC601	EI-354951	IC LM7000N
J101	EJ-359031	TERMINAL LEVER YKD31-0215 P 2P [ANTENNA]
J301	EJ-719343	PIN J YKC21-0048A 2P [OUT PUT]
L1	EO-349461	COIL FIX 2 LINK
L2	EO-349462	COIL FIX 2 U147
L3	EO-349461	COIL FIX 2 LINK
L4	EO-349462	COIL FIX 2 U147
L5	EO-349462	COIL FIX 2 U147
L6	EO-721689J	COIL FIX 1 LF-75 2R2K
L7	EO-349446	COL OSC 2 TFE2-OSC-U
L801	EO-338409	COIL LF FKOB160MH02 250UH
R303	*ER-324337	R CB H S10 FS RDS 1/4W 560J
R304	*ER-324337	R CB H S10 FS RDS 1/4W 560J
R622	*ER-322757	R CB H S10 FS RDS 1/4W 100J
R624	*ER-306805	R CB H S15 FS RDS 1/2W 101J
R801	*ER-200940	R CB H S10 FS RDS 1/4W 561J
R806	*ER-324184	R CB H S10 FS RDS 1/4W 121J
R812	*ER-322421	R CB H S10 FS RDS 1/4W 820J
SW201	ES-721688J	SW TACT SKHHLQ [RESET]
SW202	ES-344439	SW SLIDE 00420451 2-04-02 [U] [DE-EMPHA/AM-STEP]
SW801	*ES-337902	SW PUSH SLDL1P 01-1 [POWER]
SW901	*ES-349464	SW SLIDE 00120319 01-2 [U] [VOLTAGE SELECTOR]
TR1	ET-337743	TR FET 3SK107 E.F AKAI
TR2	ET-336869	TR 2SC2999 C.D
TR3	ET-328265	TR 2SC930 F
TR4	ET-349449	TR FET 2SK161 O.Y
TR101	ET-328265	TR 2SC930 F
TR102	ET-349449	TR FET 2SK161 O.Y
TR103	ET-328265	TR 2SC930 F
TR104	ET-353898	TR 2SC3330 F05
TR105	ET-353898	TR 2SC3330 F05
TR106	ET-353898	TR 2SC3330 F05
TR107	ET-349081	TR 2SC3383 S.T
TR108	*ET-336997	TR 2SB808-V G.H
TR109	ET-349718	TR 2SA1392 S.T
TR110	ET-349081	TR 2SC3383 S.T
TR111	ET-353898	TR 2SC3330 F05
TR112	ET-353898	TR 2SC3330 F05
TR113	ET-349081	TR 2SC3383 S.T [V]
TR114	ET-353899	TR 2SA1317 S.T,U [U]
TR201	ET-363326	TR FET 2SK161 GR
TR202	ET-349081	TR 2SC3383 S.T
TR203	ET-353898	TR 2SC3330 F05
TR204	ET-353898	TR 2SC3330 F05
TR205	ET-353898	TR 2SC3330 F05
TR301	ET-353898	TR 2SC3330 F05
TR302	ET-353898	TR 2SC3330 F05
TR303	ET-347961	TR 2SD1012-V G F05
TR304	ET-347961	TR 2SD1012-V G F05
TR601	ET-336997	TR 2SB808-V G.H
TR602	ET-353898	TR 2SC3330 F05
TR603	ET-336997	TR 2SB808-V G.H
TR604	ET-353898	TR 2SC3330 F05
TR605	ET-349081	TR 2SC3383 S.T
TR606	ET-337759	TR FET 2SK246 GR
TR607	ET-353898	TR 2SC3330 F05
TR608	ET-353898	TR 2SC3330 F05
TR609	ET-336997	TR 2SB808-V G.H
TR610	ET-336997	TR 2SB808-V G.H
TR801	ET-349081	TR 2SC3383 S.T
TR802	ET-349718	TR 2SA1392 S.T
TR803	ET-337759	TR FET 2SK246 GR
TR804	*ET-349459	TR 2SD1406 O.Y,GR
TR805	ET-353899	TR 2SA1317 S.T,U
TR806	ET-353899	TR 2SA1317 S.T,U
T1	EO-337640	COIL IFT 119AC-15533X 10.7MHZ
T101	EO-721703J	COIL 78-5016-01
T102	EO-721704J	COIL 78-5017-01
T201	EO-337598	COIL VARI 2 25A-1353-01
T202	EO-337599	COIL VARI 2 25A-1354-03
T203	EO-721891J	COIL A7MRS-9857X

Ref. No.	Part No.	Description
T204	EO-352089	COIL OSC 2 7BRS-9098X 580.0UH
T205	EO-721692J	COIL AM 123060
VC1	EC-721690J	C TRIMER T203Z100FR169
VC2	EC-721690J	C TRIMER T203Z100FR169
VC3	EC-721690J	C TRIMER T203Z100FR169
VC201	EC-721707J	C TRIMER T203R300FR169
VC202	EC-721707J	C TRIMER T203R300FR169
VR101	EV-353425	R S-FIX H RVF6P01 0.10W 103
VR201	EV-353558	R S-FIX H RVF6P01 0.10W 203
VR202	EV-371224	R S-FIX H RVF6P01 0.10W 303
VR203	EV-371224	R S-FIX H RVF6P01 0.10W 303
VR301	EV-371227	R S-FIX H RVF6P01 0.10W 304
VR302	EV-371227	R S-FIX H RVF6P01 0.10W 304
X301	EI-349970	OSC CE CSB456F11 0.456MHZ
X601	EI-344422	OSC X'TAL HC-18/U 7.200MHZ
F801	*EF-359342	FUSE BET T 250V 400MA [B.E.V]
F802	*EF-359342	FUSE BET T 250V 400MA [B.E.V]
F803	*EF-359342	FUSE BET T 250V 400MA [B.E.V]
F901	*EF-308933	FUSE TSC A 250V 200MA [U]

4. CONTROL P.C BOARD

Ref. No.	Part No.	Description
BT501	*EZ-358816	BATTERY LITHIUM BR2032-1HF
D501	ED-721694J	D LED MPG576X GRN
D502	ED-721694J	D LED MPG576X GRN
D503	ED-721695J	D ZENER H GZA22 X
D505	ED-721694J	D LED MPG576X GRN
D506	ED-723951J	D LED PR5524S RED
D507	ED-723951J	D LED PR5524S RED
D509	ED-721696J	D ZENER H GZA2.2 X
D510	ED-301911	D SILICON H DS448
D511	ED-301911	D SILICON H DS448
D512	ED-301911	D SILICON H DS448
D513	ED-301911	D SILICON H DS448
D514	ED-344280	D SILICON H GMA-01-FY2 F05
D515	ED-344280	D SILICON H GMA-01-FY2 F05
D516	ED-344280	D SILICON H GMA-01-FY2 F05
D517	ED-344280	D SILICON H GMA-01-FY2 F05
D518	ED-344280	D SILICON H GMA-01-FY2 F05
D519	ED-344280	D SILICON H GMA-01-FY2 F05
D520	ED-344280	D SILICON H GMA-01-FY2 F05
D521	ED-344280	D SILICON H GMA-01-FY2 F05 [U]
D522	ED-721694J	D LED MPG576X GRN
D523	ED-721694J	D LED MPG576X GRN
D524	ED-721694J	D LED MPG576X GRN
D525	ED-721694J	D LED MPG576X GRN
D526	ED-721694J	D LED MPG576X GRN
IB501	EH-355260	COMP R RGLD12X104J
IB502	EH-359120	COMP R RGLD4X104J
IC501	EI-356457	IC BU4013B
IC502	EI-356457	IC BU4013B
IC503	EI-358818	IC A3048-714 AKAI COSTOM
IC504	EI-345551	IC LB1403
SW501	ES-349367	SW TACT SKHHAK003A
SW502	ES-349367	SW TACT SKHHAK003A
SW503	ES-349367	SW TACT SKHHAK003A
SW504	ES-349367	SW TACT SKHHAK003A
SW505	ES-349367	SW TACT SKHHAK003A
SW506	ES-349367	SW TACT SKHHAK003A
SW507	ES-349367	SW TACT SKHHAK003A
SW508	ES-349367	SW TACT SKHHAK003A
SW509	ES-349367	SW TACT SKHHAK003A
SW510	ES-349367	SW TACT SKHHAK003A
SW511	ES-349367	SW TACT SKHHAK003A
SW512	ES-349367	SW TACT SKHHAK003A
SW513	ES-349367	SW TACT SKHHAK003A
SW514	ES-349367	SW TACT SKHHAK003A

Ref. No.	Part No.	Description
SW515	ES-349367	SW TACT SKHHA003A
SW516	ES-349367	SW TACT SKHHA003A
TN501	EM-353670	ND FL 8-BT-29ZK CHARACTER
TR501	ET-353898	TR 2SC3330 F05
TR502	ET-349592	TR 2SC3400 F05
TR503	ET-353898	TR 2SC3330 F05
TR504	ET-349592	TR 2SC3400 F05
TR505	ET-353898	TR 2SC3330 F05
TR506	ET-353898	TR 2SC3330 F05
TR507	ET-349718	TR 2SA1392 S.T
TR508	ET-353898	TR 2SC3330 F05
TR509	ET-349718	TR 2SA1392 S.T
		[U]
X501	EI-348409	OSC CE CSB400P 0.400000MHZ

ASSEMBLY BLOCK

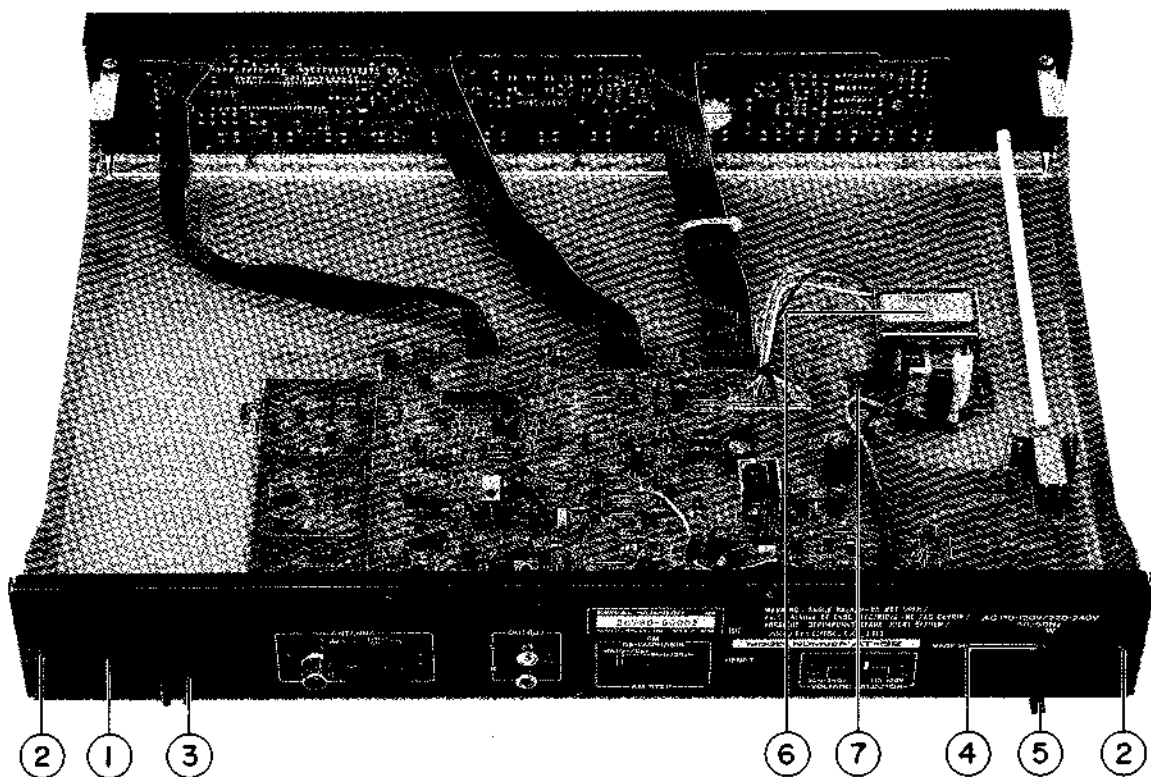

5. ASSEMBLY BLOCK

Ref. No.	Part No.	Description
1A	SP-721712J	PANEL REAR AT-52 (U)
1B	SP-721257	PANEL REAR AT-52(E,V)
1C	SP-721244	PANEL REAR AT-52L (B)
1D	SP-721256	PANEL REAR AT-52L (E)
2	ZS-308846	T2BR30X08STL BZN PROJECTION
3	SZ-362273	HOLDER ANTENNA (2)
4A	*EZ-345815	STOPPER CORD CM-22A
4B	*EZ-345816	STOPPER CORD CM-22B
4C	*EZ-357913	STOPPER CORD CM-22C

Ref. No.	Part No.	Description
5A	*EW-359448	AC CORD 2C KP700A,VFF-CB U/T
5C	*EW-355033	AC CORD 2 CORES KP-419C, LTCE-
5E	*EW-355034	AC CORD 2 CORES LTBS-2F-CB B
6A	*BT-721687J	TRANS POWER AT-52 (U)
6B	*BT-721684J	TRANS POWER AT-52/L(E,V)
6C	*BT-721685J	TRANS POWER AT-52/L (B)
7	ZS-315511	ST PAN30X06STL CMT CUP

PARTS LIST

FINAL ASSEMBLY BLOCK

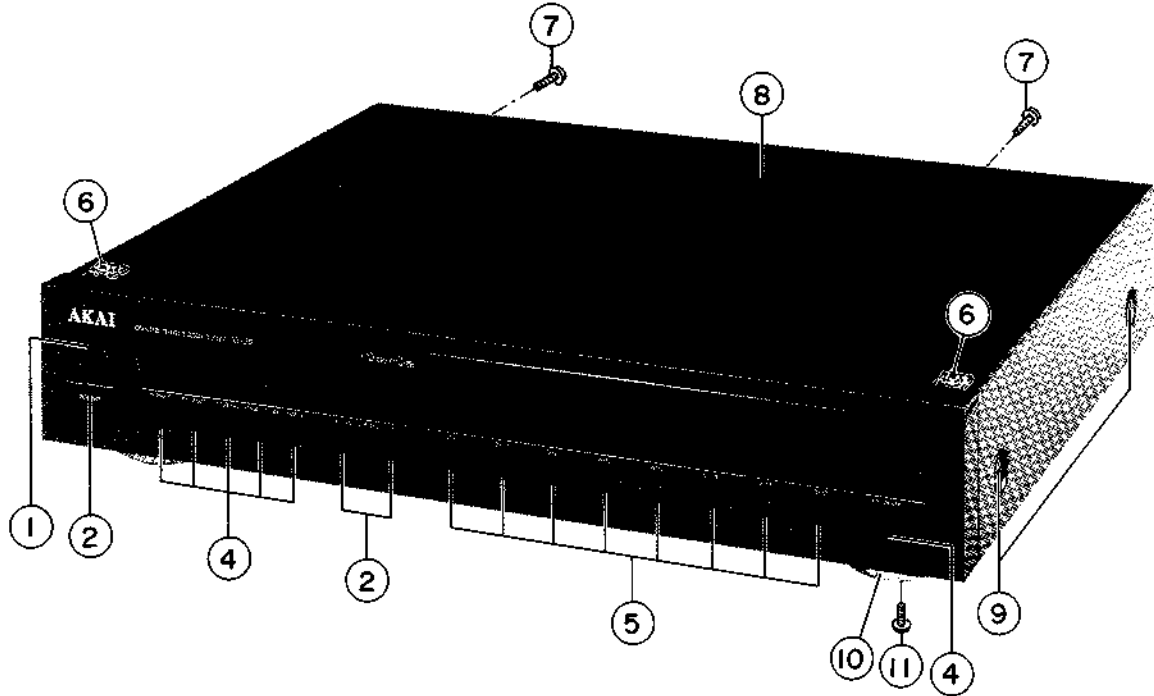

6. FINAL ASSEMBLY BLOCK

Ref. No.	Part No.	Description
1A-G	BD-721253	PANEL FRONT BLK AT-52-G
1A-B	BD-721252	PANEL FRONT BLK AT-52-B
1B-B	BD-721716J	PANEL FRONT BLK AT-52L-B
2-G	SK-373236A	KNOB POWER-G
2-B	SK-373236B	KNOB POWER-B
3-G	SK-721250	KNOB TUNING-G
3-B	SK-721249	KNOB TUNING-B
4-G	SK-368675A	KNOB BAND G
4-B	SK-368675B	KNOB BAND B
5-G	SK-721262	KNOB PUSH-G
5-B	SK-721261	KNOB PUSH-B
6	ZS-447840	T2BR30X08STL CMT
7	ZS-463353	T2BR30X08STL BNI
8-G	SP-368689A	COVER UPPER-G
8-B	SP-368689B	COVER UPPER-B
9-G	ZS-341959	ST BID40X06STL NIS
9-B	ZS-341960	ST BID40X06STL BNI
10	SA-379375	FOOT(N)
11	ZS-331567	T2BR30X08STL CMT C080

ACCESSORY

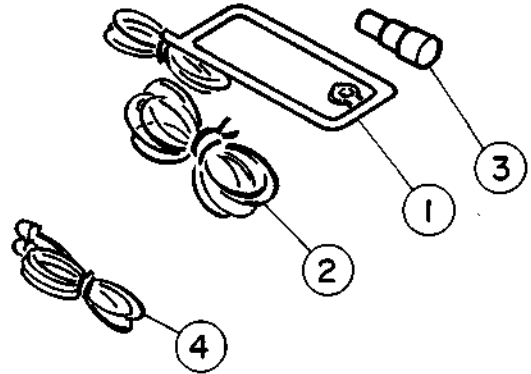

7. ACCESSORY

Ref. No.	Part No.	Description
1	EE-359265	ANT LOOP LA-200A-A
2	EE-315329	ANT DIPOLE SAE-010
3	EJ-352118	SOCKET COAX PAL B2-714P-900
4	EW-344151	CORD RR-61A PINX2-PINX2

INDEX

Part No.	Ref. No.	Part No.	Ref. No.	Part No.	Ref. No.	Part No.	Ref. No.
BA-721699J	1D	ED-712928	19	EO-349462	L2	ET-349718	TR509
BA-721700J	1C	ED-712928	D807	EO-349462	L4	ET-353898	52
BA-721701J	1A	ED-715992	14	EO-349462	L5	ET-353898	TR104
BA-721702J	1B	EO-715992	D808	EO-352089	T204	ET-353898	TR105
BA-722674J	2	ED-715992	D810	EO-721689J	L6	ET-353898	TR106
BD-721252	1A-B	ED-721694J	4	EO-721689J	T203	ET-353898	TR111
BD-721253	1A-G	ED-721694J	D501	EO-721692J	T205	ET-353898	TR112
BD-721716J	1B-B	ED-721694J	D502	EO-721703J	T101	ET-353898	TR203
BT-721684J	3	ED-721694J	D505	EO-721704J	T102	ET-353898	TR204
BT-721684J	6B	ED-721694J	D522	ER-200940	R801	ET-353898	TR205
BT-721685J	2	ED-721694J	D523	ER-306805	R624	ET-353898	TR301
BT-721685J	6C	ED-721694J	D524	ER-322421	R812	ET-353898	TR302
BT-721687J	1	ED-721694J	D525	ER-322787	R622	ET-353898	TR602
BT-721687J	6A	ED-721694J	D526	ER-324184	R806	ET-353898	TR604
EC-320548	C801	ED-721695J	16	ER-324337	R303	ET-353898	TR607
EC-320548	C814	ED-721695J	D808	ER-324337	R304	ET-353898	TR608
EC-338496	C813	ED-721695J	D503	ES-337902	39	ET-353898	TR501
EC-721690J	VC1	ED-721696J	15	ES-337902	SW801	ET-353898	TR503
EC-721690J	VC2	ED-721696J	D509	ES-344439	41	ET-353898	TR505
EC-721690J	VC3	ED-723951J	5	ES-344439	SW202	ET-353898	TR506
EC-721707J	VC201	ED-723951J	D506	ES-349367	42	ET-353898	TR508
EC-721707J	VC202	ED-723951J	D507	ES-349367	SW501	ET-353899	48
ED-301911	8	EE-315329	2	ES-349367	SW502	ET-353899	TR114
ED-301911	D108	EE-359265	1	ES-349367	SW503	ET-353899	TR805
ED-301911	D301	EF-308933	22	ES-349367	SW504	ET-353899	TR806
ED-301911	D510	EF-308933	F901	ES-349367	SW505	ET-363326	44
ED-301911	D511	EF-359342	21	ES-349367	SW506	ET-363326	TR201
ED-301911	D512	EF-359342	F801	ES-349367	SW507	EV-353425	VR101
ED-301911	D513	EF-359342	F802	ES-349367	SW508	EV-353558	VR201
ED-336832-A	11	EF-359342	F803	ES-349367	SW509	EV-371224	VR202
ED-336832-A	D1	EH-315407	24	ES-349367	SW510	EV-371224	VR203
ED-336832-A	D2	EH-315407	FL101	ES-349367	SW511	EV-371227	VR301
ED-336832-A	D3	EH-315407	FL102	ES-349367	SW512	EV-371227	VR302
ED-336832-A	D4	EH-315407	FL103	ES-349367	SW513	EW-344151	4
ED-344280	9	EH-315407	FL104	ES-349367	SW514	EW-355033	5C
ED-344280	D101	EH-344434	23	ES-349367	SW515	EW-355034	5E
ED-344280	D102	EH-344434	FL202	ES-349367	SW516	EW-359448	5A
ED-344280	D103	EH-355260	IB501	ES-349464	40	EZ-345815	4A
ED-344280	D104	EH-359120	IB502	ES-349464	SW901	EZ-345816	4B
ED-344280	D105	EH-706132	25	ES-721688J	43	EZ-357913	4C
ED-344280	D106	EH-706132	FL201	ES-721688J	SW201	EZ-358816	5B
ED-344280	D107	EH-721705J	26	ET-328265	55	EZ-358816	BT501
ED-344280	D109	EH-721705J	FL301	ET-328265	TR3	SA-379375	10
ED-344280	D110	EH-721705J	FL302	ET-328265	TR101	SK-368675A	4-G
ED-344280	D111	EH-721706J	27	ET-328265	TR103	SK-368675B	4-B
ED-344280	D204	EH-721706J	FL105	ET-336869	51	SK-373236A	2-G
ED-344280	D205	EI-337964	29	ET-336869	TR2	SK-373236B	2-B
ED-344280	D601	EI-337964	IC101	ET-336997	50	SK-721249	3-B
ED-344280	D603	EI-337964	IC102	ET-336997	TR108	SK-721250	3-G
ED-344280	D801	EI-344422	37	ET-336997	TR601	SK-721261	5-B
ED-344280	D802	EI-344422	X601	ET-336997	TR603	SK-721262	5-G
ED-344280	D811	EI-345551	33	ET-336997	TR609	SP-368689A	8-G
ED-344280	D813	EI-345551	IC504	ET-336997	TR610	SP-368689B	8-B
ED-344280	D814	EI-348409	35	ET-337743	47	SP-721244	1C
ED-344280	D815	EI-348409	X501	ET-337743	TR1	SP-721256	1D
ED-344280	D514	EI-349963	32	ET-337759	46	SP-721257	1B
ED-344280	D515	EI-349963	IC301	ET-337759	TR606	SP-721712J	1A
ED-344280	D616	EI-349970	36	ET-337759	TR803	SZ-362273	3
ED-344280	D517	EI-349970	X301	ET-347961	56	ZS-308846	2
ED-344280	D518	EI-354951	34	ET-347961	TR303	ZS-315511	7
ED-344280	D519	EI-354951	IC601	ET-347961	TR304	ZS-331567	11
ED-344280	D520	EI-356457	30	ET-349081	53	ZS-341959	9-G
ED-344280	D521	EI-356457	IC501	ET-349081	TR107	ZS-341960	9-B
ED-345555	6	EI-356457	IC502	ET-349081	TR110	ZS-447840	6
ED-345555	D804	EI-356818	28	ET-349081	TR113	ZS-463353	7
ED-353692-A	12	EI-356818	IC503	ET-349081	TR202		
ED-353692-A	D202	EI-719341	31	ET-349081	TR605		
ED-353692-A	D203	EI-719341	IC103	ET-349081	TR801		
ED-357754	7	EJ-352118	3	ET-349449	45		
ED-357754	D803	EJ-359031	J101	ET-349449	TR4		
ED-371782	10	EJ-719343	J301	ET-349449	TR102		
ED-371782	D201	EM-353670	38	ET-349459	57		
ED-708046	18	EM-353670	TN501	ET-349459	TR804		
ED-708046	D812	EO-337598	T201	ET-349592	54		
ED-712000	17	EO-337598	T202	ET-349592	TR502		
ED-712000	D809	EO-337640	T1	ET-349592	TR504		
ED-712926	13	EO-338409	LB01	ET-349718	49		
ED-712926	D805	EO-349446	L7	ET-349718	TR109		
ED-712927	20	EO-349461	L1	ET-349718	TR802		
ED-712927	D602	EO-349461	L3	ET-349718	TR507		

AKAI

MODEL AT-52/L

SCHEMATIC DIAGRAM AND PC BOARDS

TABLE OF CONTENTS

1. CONTROL P.C.B.	1
2. TUNER P.C.B.	2
3. SCHEMATIC DIAGRAM	5
4. BLOCK DIAGRAM	6

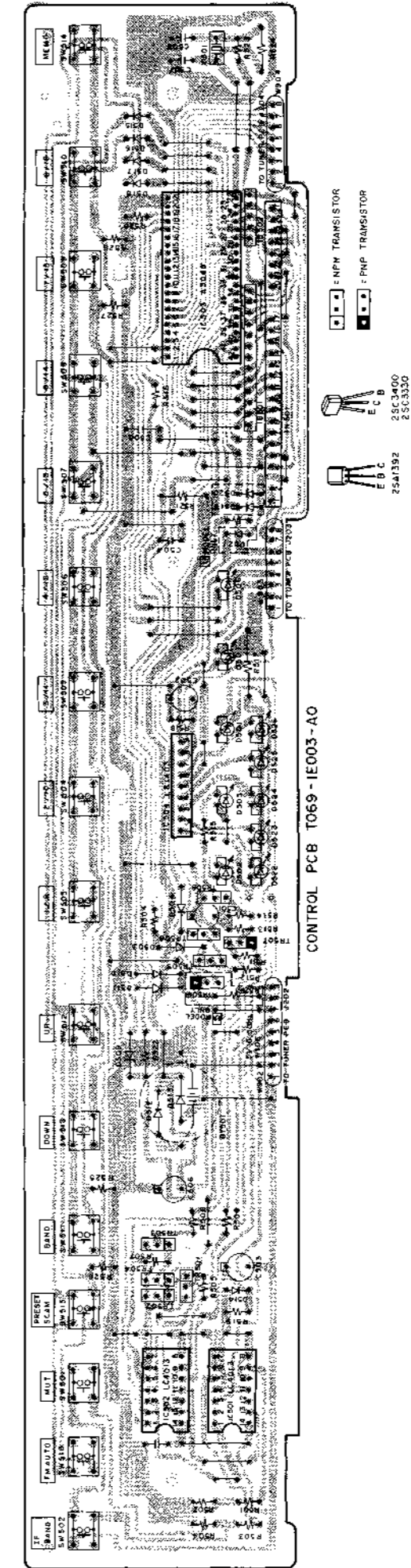

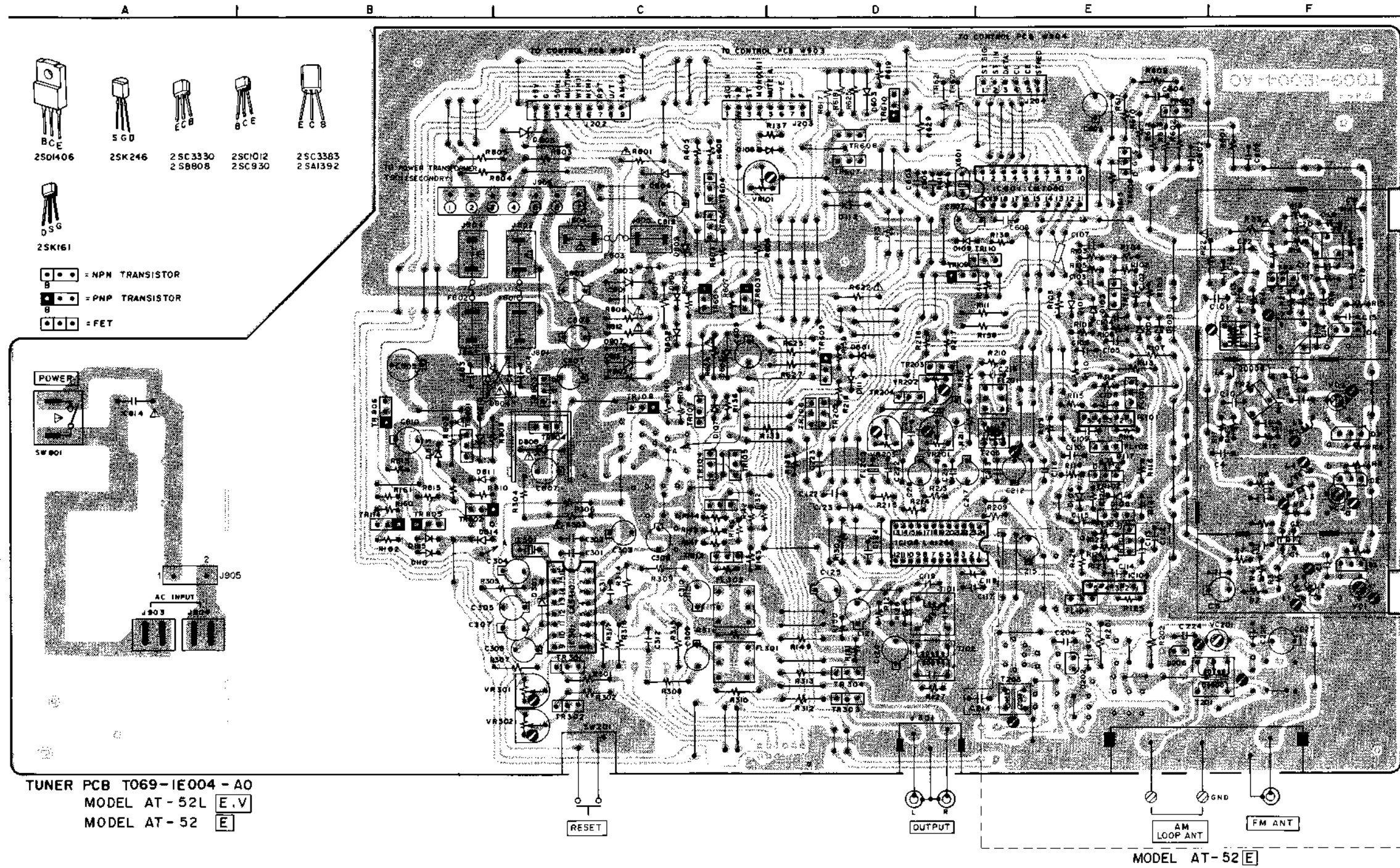

TUNER PCB T069-1E004-A0
 MODEL AT-52L [E,V]
 MODEL AT-52 [E]

- LOCATION OF COMPONENTS
- IC's
 IC101.....E3
 IC102.....E3
 IC103.....D3
 IC301.....C4
 IC601.....E1
- TRANSISTORS
 TR101.....E2
 TR102,103...E3
 TR104,105...C3
 TR106.....D2
 TR107,108...C3
 TR109.....D2
 TR110.....E2
 TR111,112...C3
 TR114.....B3
 TR201,202...B4
 TR302.....C4
 TR303,304...D4
 TR602.....C2
 TR603.....C2
 TR604.....C1
 TR605.....E1
 TR606.....E1
 TR607,608...D1
 TR610.....D1
 TR801.....B3
 TR802.....B3
 TR803.....C2
 TR804.....C2
 TR805.....B3
 TR806.....B3
- TERMINALS
 J202.....C1
 J203.....C1
 J204.....E1
- ADJUSTMENT POINTS
 L1.....FM LOW
 L2.....FM HIGH
 L4.....FM LOW
 L5.....FM LOW
 L7.....FM LOW
 VC1.....FM HIGH
 VC2.....FM HIGH
 VC3.....FM HIGH
 VC201...MW HIGH
 VC202...LW HIGH
 T1.....FM LOW
 T5.....AM IF
 T202...LW LOW
 T203...MW OSC
 T204...MW OSC
 VR202...FM MUTING
- NARROW
 VR203...FM MUTING
 WIDE
 VR301...MPX NARROW
 VR302...MPX WIDE
 VR101...FM SIGNAL
 INDICATOR

WARNING: ⚠ INDICATES SAFETY CRITICAL COMPONENTS FOR CONTINUED SAFETY.
 REPLACE SAFETY CRITICAL COMPONENTS ONLY WITH MANUFACTURER'S
 RECOMMENDED PARTS

AVERTISSEMENT: ⚠ IL INDIQUE LES COMPOSANTS CRITIQUES DE SÉCURITÉ.
 POUR MAINTENIR LE DEGRÉ DE SÉCURITÉ DE L'APPAREIL,
 NE REMPLACER QUE DES PIÈCES RECOMMANDÉES PAR LE FABRICANT

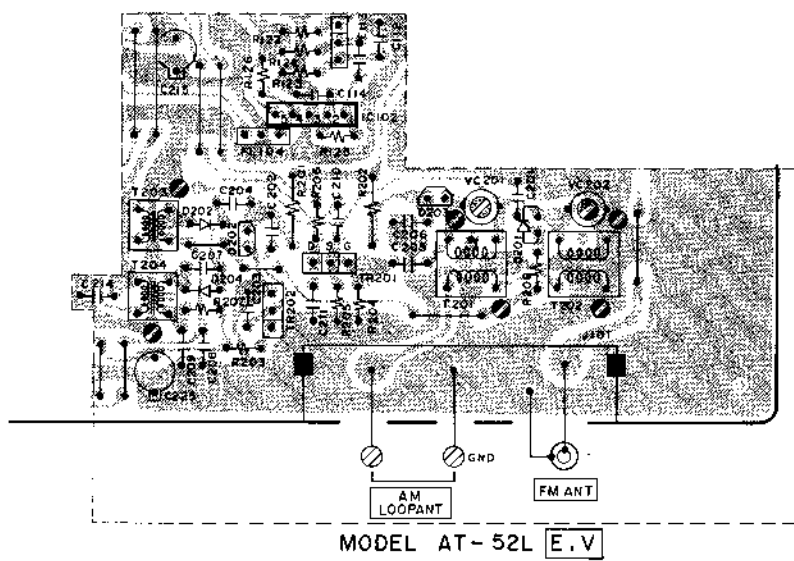

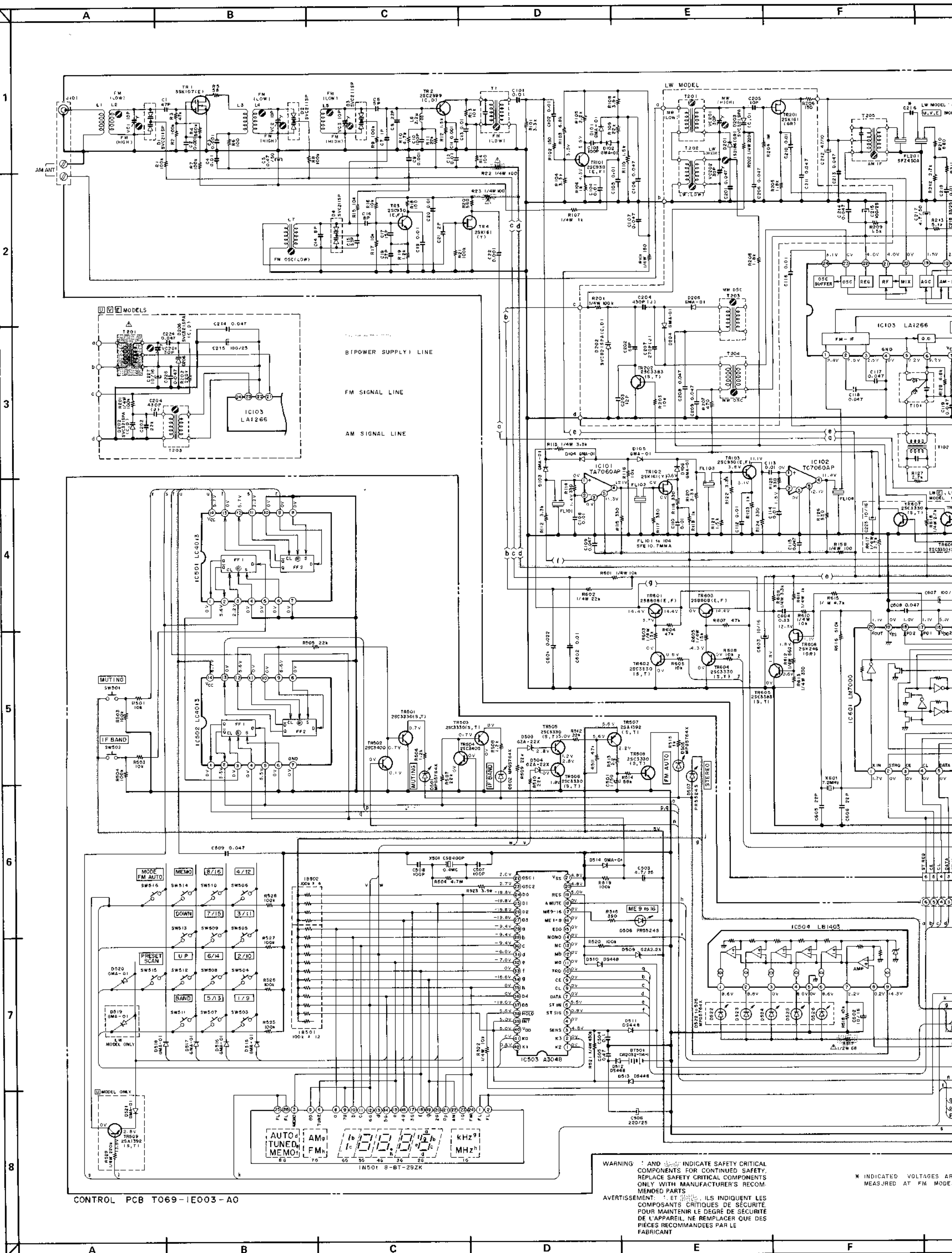

CONTROL PCB T069-1E003-A0

WARNING: ! AND * INDICATE SAFETY CRITICAL COMPONENTS FOR CONTINUED SAFETY. REPLACE SAFETY CRITICAL COMPONENTS ONLY WITH MANUFACTURER'S RECOMMENDED PARTS.

AVERTISSEMENT: ! ET * ILS INDICENT LES COMPOSANTS CRITIQUES DE SECURITE POUR MAINTENIR LE DEGRE DE SECURITE DE L'APPAREIL. NE REMPLACER QUE DES PIECES RECOMMANDEES PAR LE FABRICANT.

* INDICATED VOLTAGES ARE MEASURED AT FM MODE.

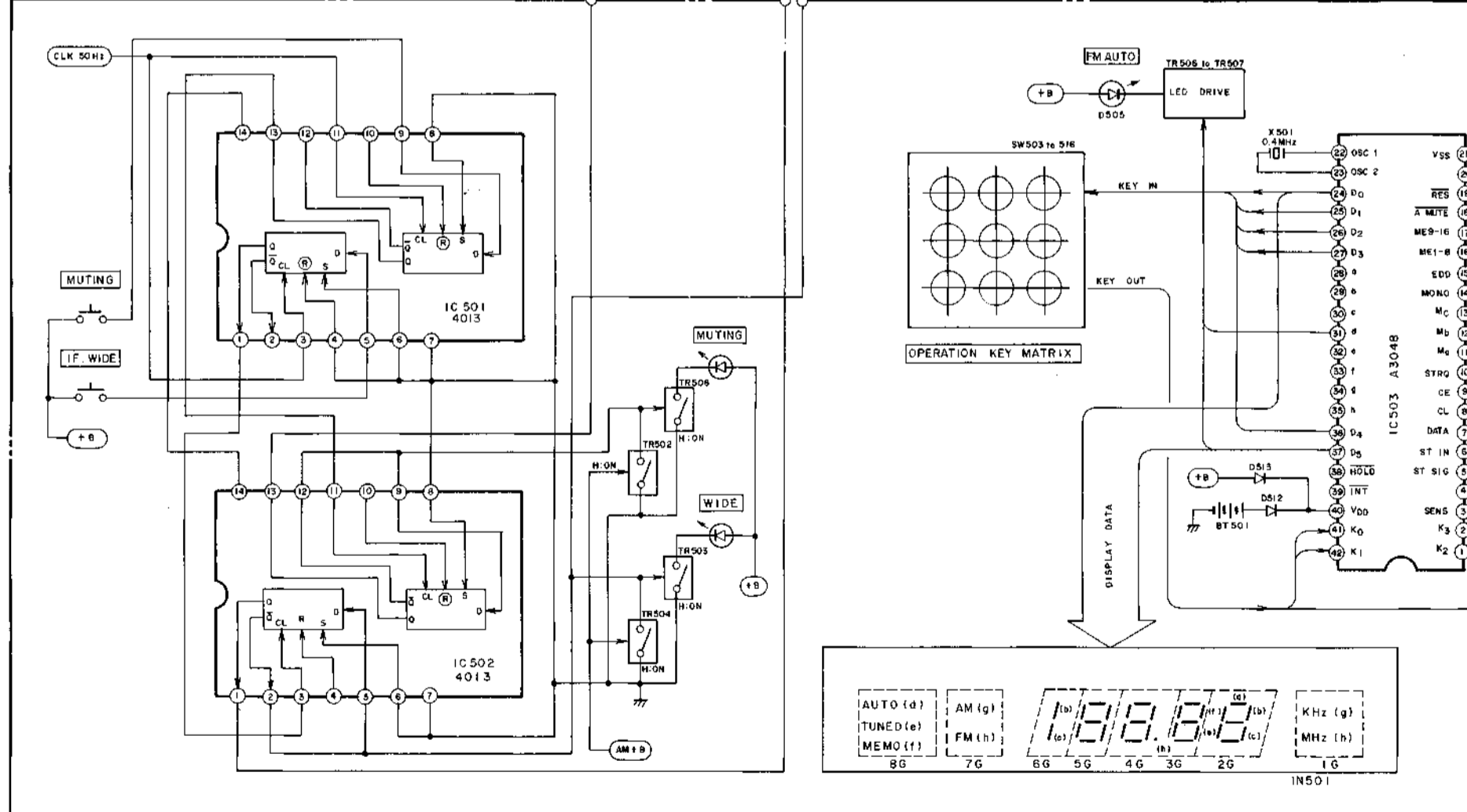
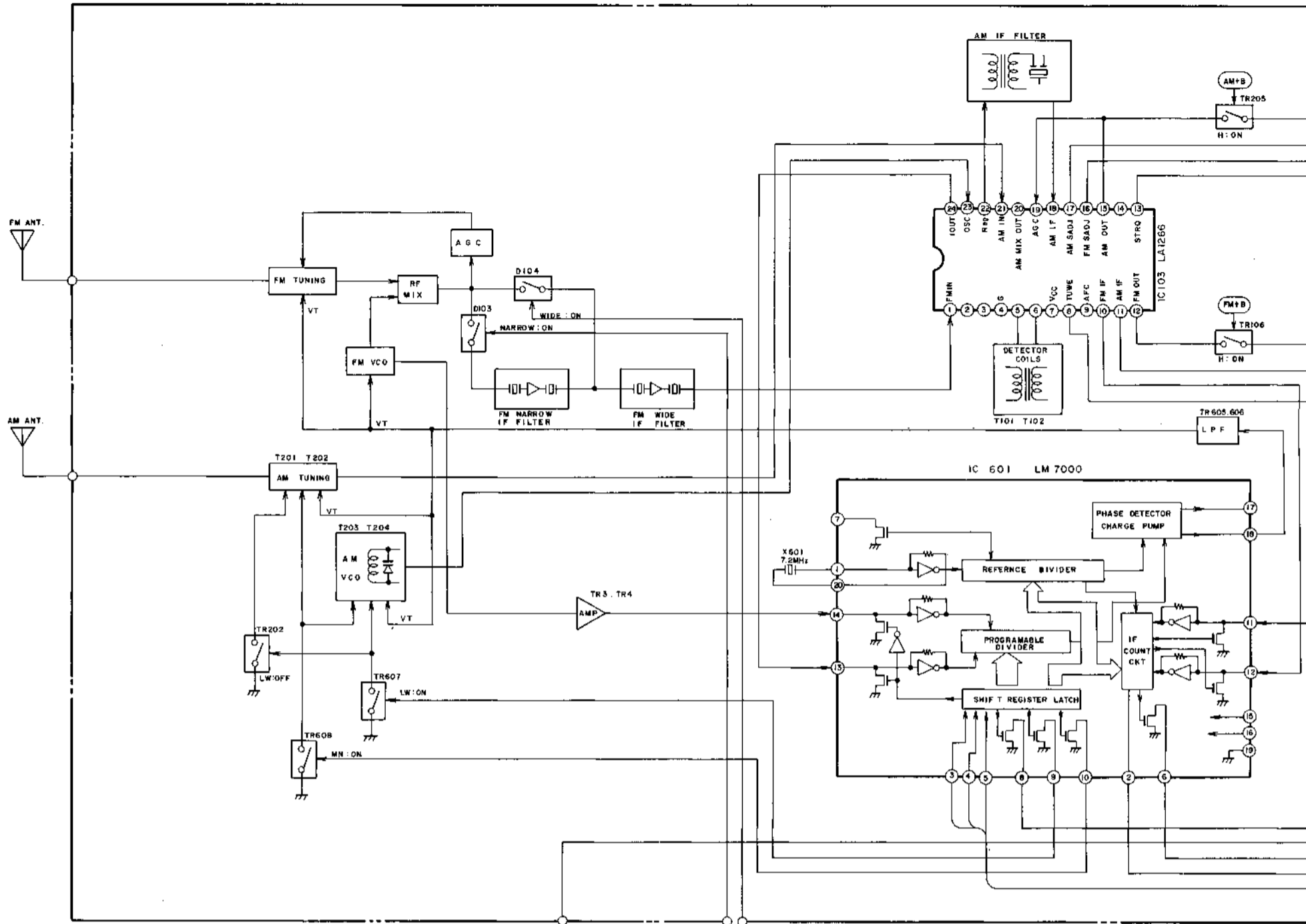

CONTROL BLOCK

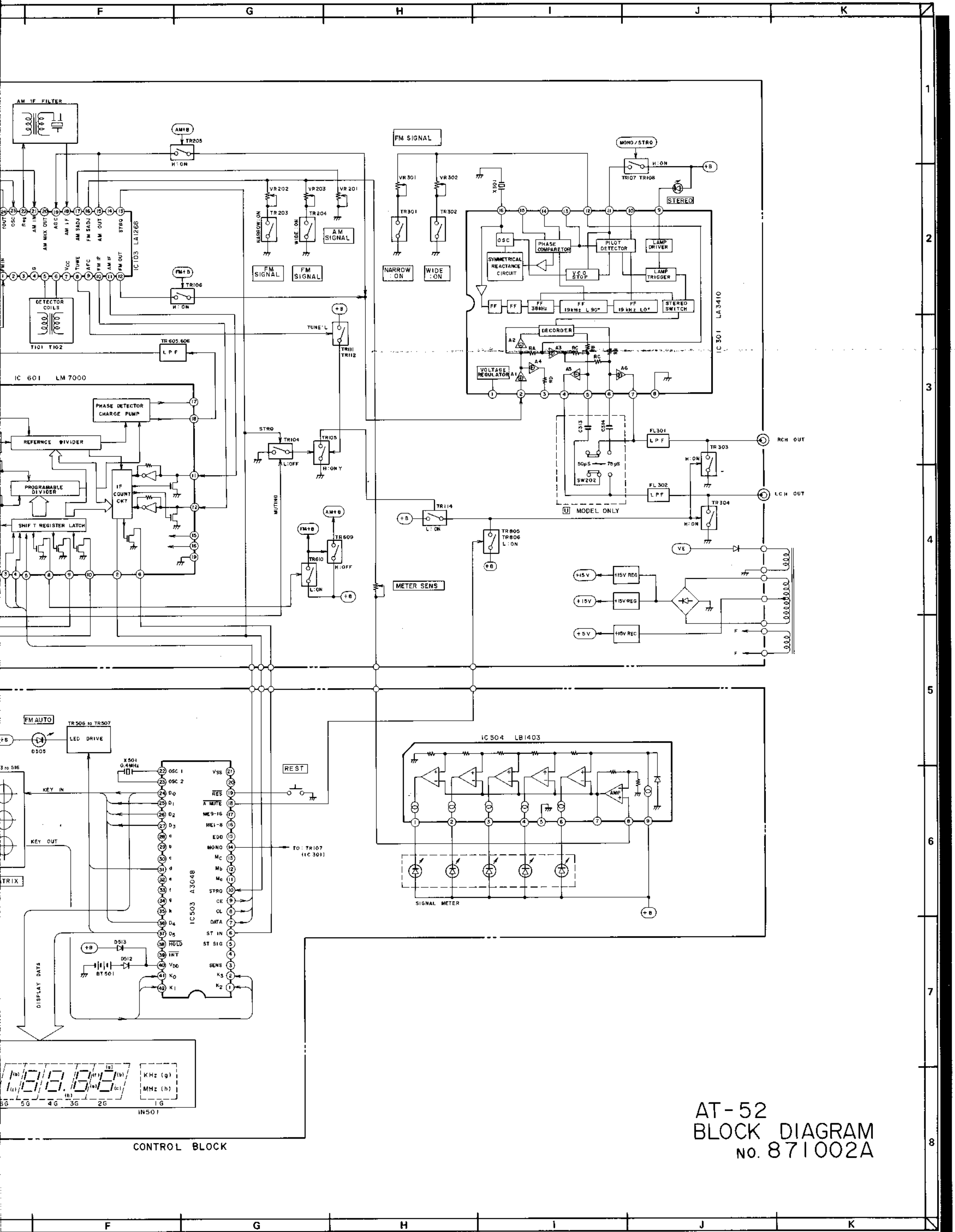

AT-52
BLOCK DIAGRAM
No. 871002A

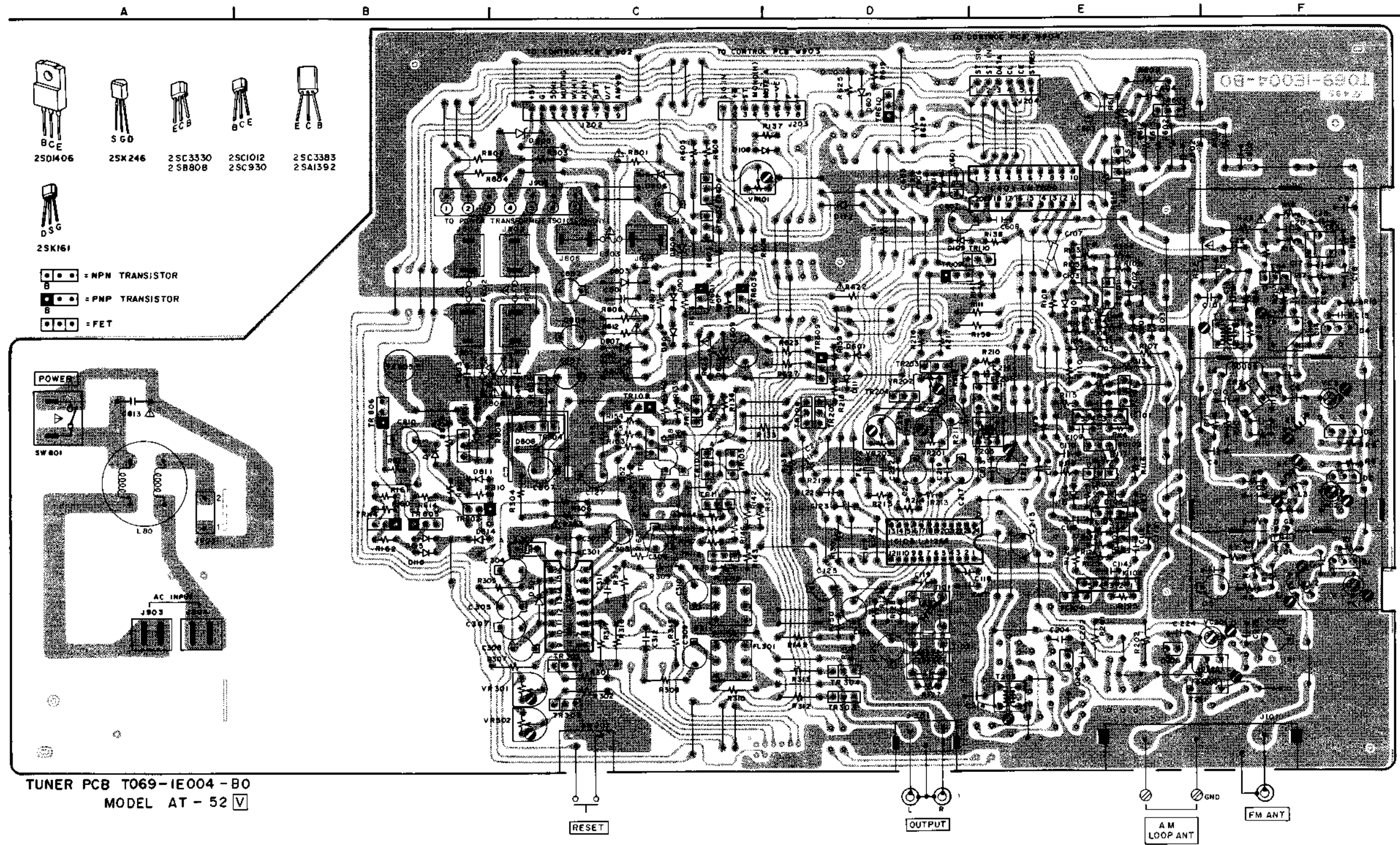

TUNER PCB T069-1E004-B0
MODEL AT-52

- LOCATION OF COMPONENTS
- IC's
 IC101.....E3
 IC102.....E3
 IC103.....D3
 IC301.....C4
 IC601.....B1
- TRANSISTORS
 TR101.....E2
 TR102, 103...E3
 TR104, 105...C3
 TR106.....D2
 TR107, 108...C3
 TR109.....D2
 TR110.....E2
 TR111, 112...C3
 TR113.....C3
 TR114.....B3
 TR302.....C4
 TR303, 304...D4
 TR602.....C2
 TR603.....C2
 TR604.....C1
 TR605.....E1
 TR606.....E1
 TR607, 608...D1
 TR610.....D1
 TR801.....B3
 TR802.....B3
 TR803.....C2
 TR804.....C2
 TR805.....B3
 TR806.....B3
- TERMINALS
 J202.....C1
 J203.....C1
 J204.....E1
- ADJUSTMENT POINTS
 L1.....FM LOW
 L2.....FM HIGH
 L4.....FM LOW
 L5.....FM LOW
 L7.....FM LOW
 VC1.....FM HIGH
 VC2.....FM HIGH
 VC3.....FM HIGH
 VC201...MW HIGH
 VC202...LW HIGH
 T1.....FM LOW
 T5.....AM IF
 VR202...FM MUTING
 NARROW
 VR203...FM MUTING
 WIDE
 VR301...MPX NARROW
 VR302...MPX WIDE
 VR101...FM SIGNAL
 INDICATOR

WARNING: Δ INDICATES SAFETY CRITICAL COMPONENTS. FOR CONTINUED SAFETY, REPLACE SAFETY CRITICAL COMPONENTS ONLY WITH MANUFACTURER'S RECOMMENDED PARTS.

AVERTISSEMENT: Δ IL INDIQUE LES COMPOSANTS CRITIQUES DE SÉCURITÉ. POUR MAINTENIR LE DEGRÉ DE SÉCURITÉ DE L'APPAREIL, NE REMPLACER QUE DES PIÈCES RECOMMANDÉES PAR LE FABRICANT.

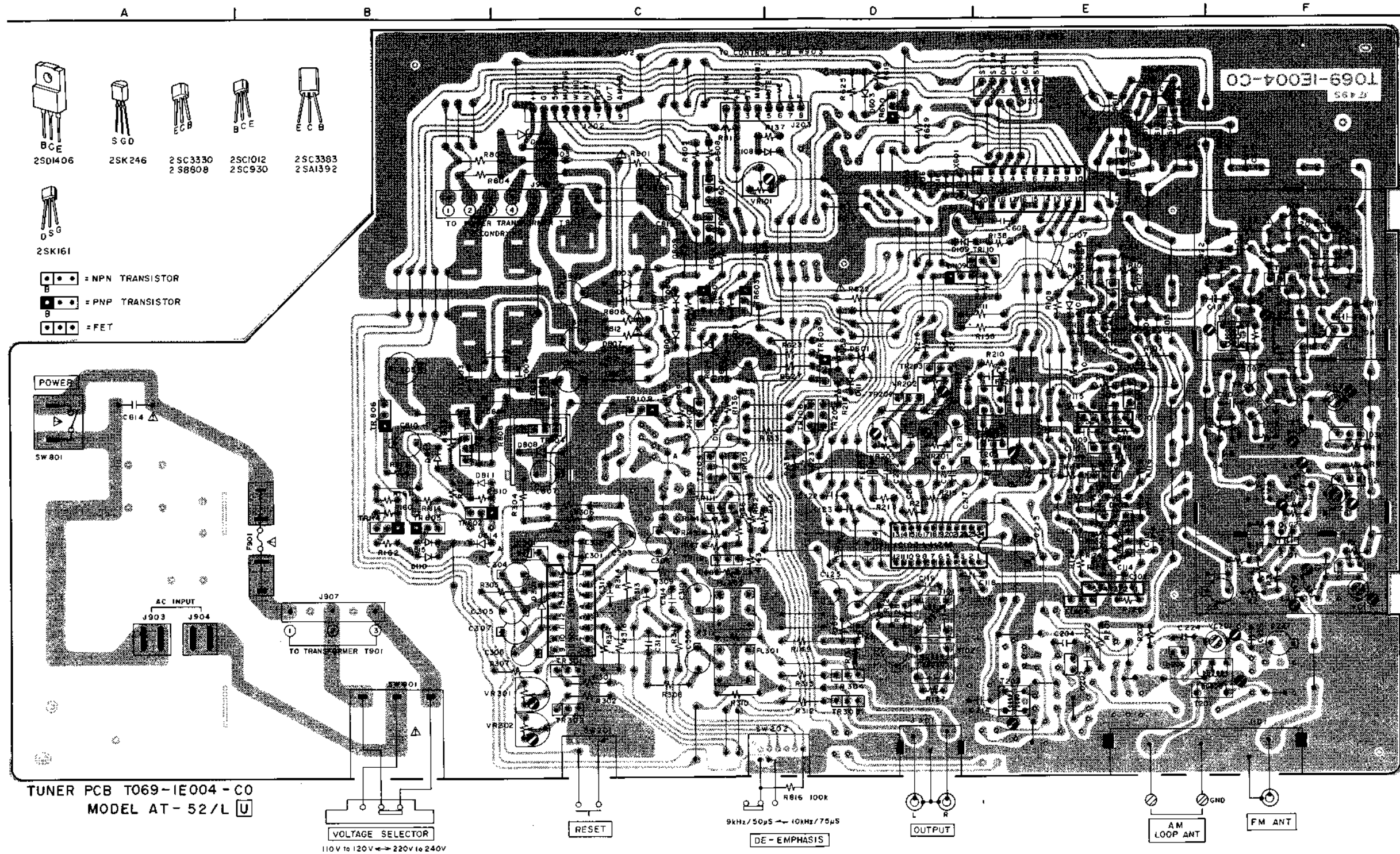

TUNER PCB T069-1E004-C0
MODEL AT-52/L U

LOCATION OF COMPONENTS
IC's
IC101.....E3
IC102.....E3
IC103.....D3
IC301.....C4
IC601.....E1

TRANSISTORS

TR101.....E2
TR102, 103...E3
TR104, 105...C3
TR106.....D2
TR107, 108...C3
TR109.....D2
TR110.....E2
TR111, 112...C3
TR114.....B3
TR302.....C4
TR303, 304...D4
TR602.....C2
TR603.....C2
TR604.....C1
TR605.....E1
TR606.....E1
TR610.....D1
TR801.....B3
TR802.....B3
TR803.....C2
TR804.....C2
TR805.....B3
TR806.....B3

TERMINALS

J202.....C1
J203.....C1
J204.....E1

ADJUSTMENT POINTS

L1.....FM LOW
L2.....FM HIGH
L4.....FM LOW
L5.....FM LOW
L7.....FM LOW
VC1.....FM HIGH
VC2.....FM HIGH
VC3.....FM HIGH
VC201...MW HIGH
VC202...LW HIGH
T1.....FM LOW
T5.....AM IF
T203...MW OSC
T204...MW OSC
VR202...FM MUTIONG
NARROW
VR203...FM MUTING
WIDE
VR301...MPX NARROW
VR302...MPX WIDE
VR101...FM SIGNAL
INDICATOR

WARNING: Δ INDICATES SAFETY CRITICAL COMPONENTS FOR CONTINUED SAFETY.
REPLACE SAFETY CRITICAL COMPONENTS ONLY WITH MANUFACTURER'S
RECOMMENDED PARTS

AVERTISSEMENT: Δ IL INDIQUE LES COMPOSANTS CRITIQUES DE SÉCURITÉ.
POUR MAINTENIR LE DEGRÉ DE SÉCURITÉ DE L'APPAREIL,
NE REMPLACER QUE DES PIÈCES RECOMMANDÉES PAR LE FABRICANT