

SERVICE MANUAL

PARTS LIST

AKAI STEREO TAPE RECORDER

1721W

NOTE: ALSO APPLICABLE TO MODEL TET-1721W

IV. OPEN REEL MECHANISM ADJUSTMENTS

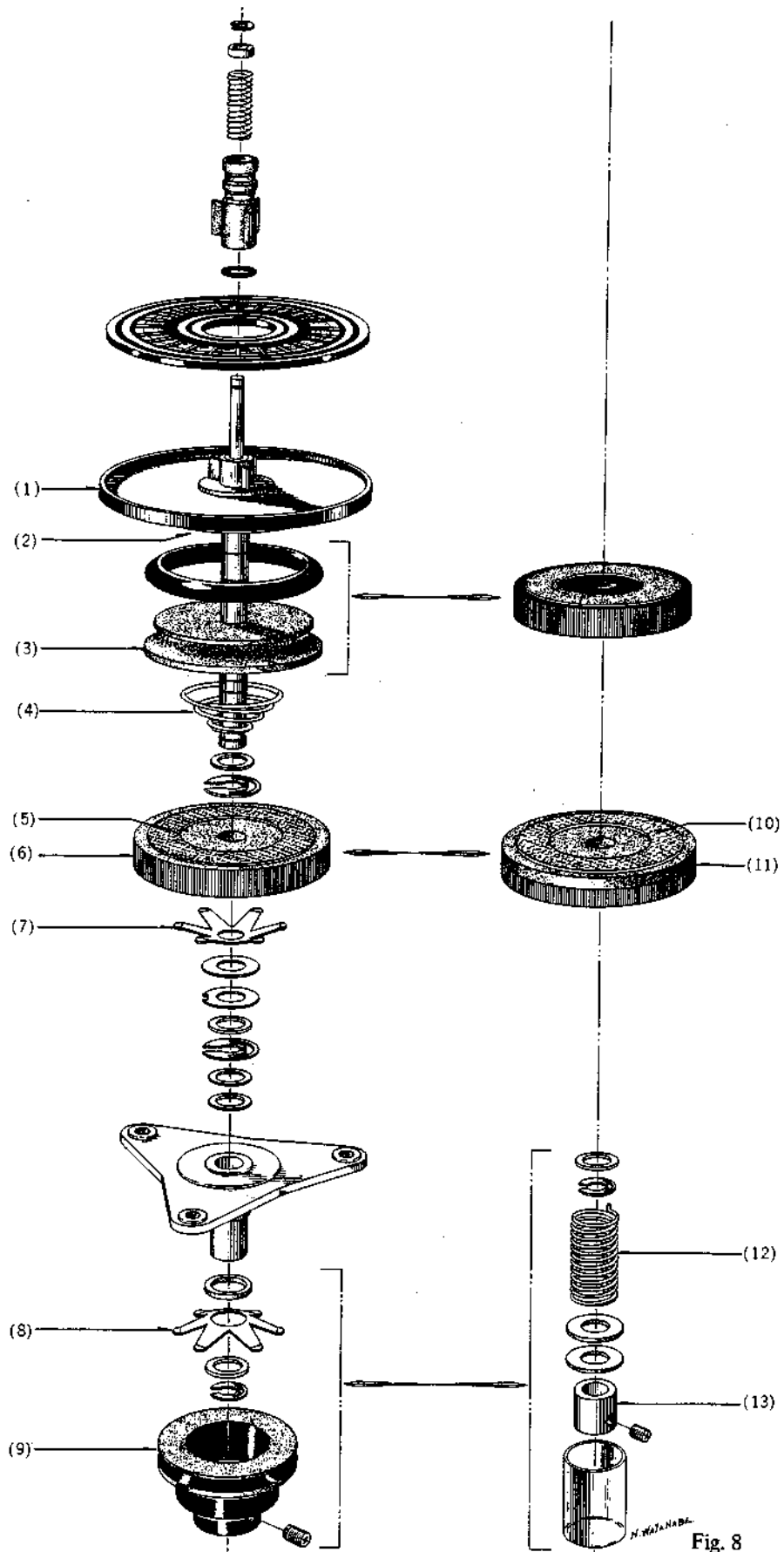

N. WATANABE
Fig. 8

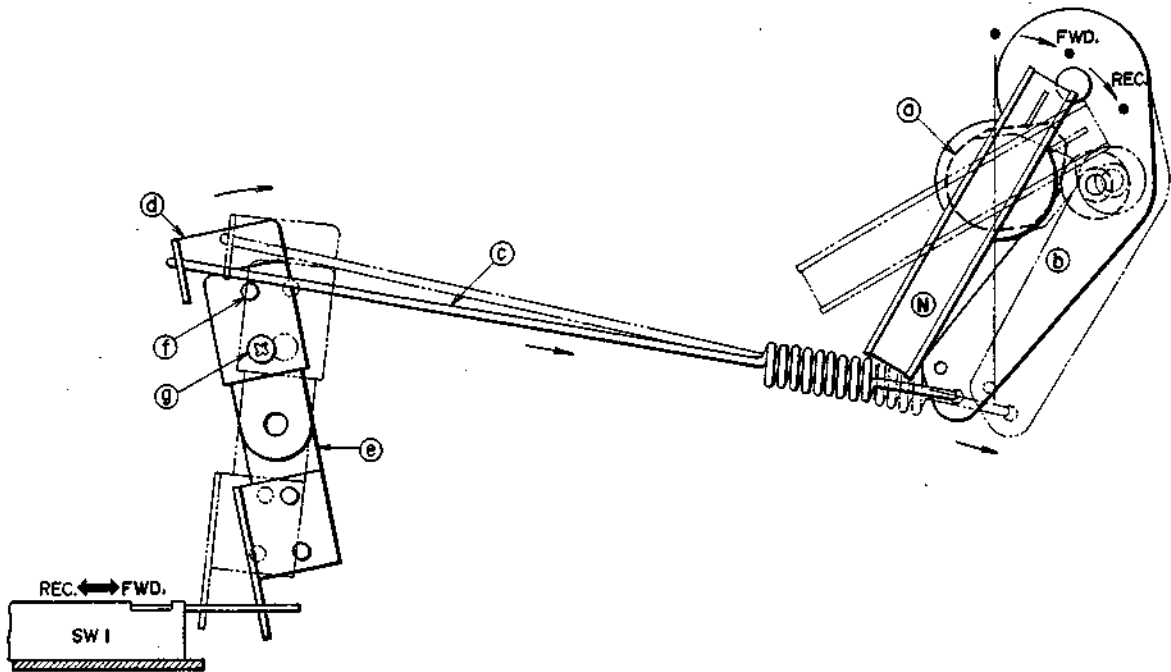

Fig. 9

1. PINCH WHEEL ADJUSTMENT

It is important that the pinch wheel shaft be kept in perfect alignment with the capstan shaft. Proper pinch wheel pressure is between 1,000 and 1,150 grams when the unit is operated at the tape speed of 7-1/2 ips. Any deviation from this specification will result in wow and flutter. Check pinch wheel pressure with a spring scale, and if necessary, adjust the pinch wheel load spring.

2. SUPPLY REEL SHAFT ASSEMBLY ADJUSTMENT (See Fig. 8 at left)

Felt clutch material (2) is used between the lower side of the reel table base plate (1) and the rewind pulley (3) to protect recording tape from excessive tension during rewind operation. To check the amount of friction of this part, install a 5-inch reel with a 60 mm diameter tape, and gently pull the end of the tape upward with a spring scale. Adjust the conical spring (4) so that the amount of tension is kept between 400 and 500 grams. Other felt clutch material (5) is attached to the supply roller (6) to provide proper slippage during FWD and REC operation. The procedure for checking friction of this part is the same as the foregoing, and between 80 and 100 grams of tension gives best result. Adjust the spring (7) just under the supply roller (6). When the unit is set to fast forward operation, the amount of friction will decrease to from 15 to 20 grams. Check to see whether this is satisfactory. If not, adjust the spring plate (8) and the pressure of the pulley (9).

3. TAKE-UP REEL SHAFT ASSEMBLY ADJUSTMENT (See Fig. 8 at right)

Felt clutch material (2) is attached to the bottom side of the reel table base plate (1) so that the recording tape will not stretch during fast forward operation due to excessive tension. To check the amount of friction of this part, install a 5-inch reel with a 60 mm diameter tape, and gently pull the end of tape upward with a spring scale. Adjust the conical spring (4) so that the amount of tension at this part is kept between 400 and 500 grams. Other felt clutch material (1) is attached to the take-up roller (11). This is to provide proper slippage during FWD or REC operation. The procedure for checking friction of this part is the same as the foregoing, and between 150 and 180 grams of friction provides the best results. Adjust the spring plate (7) just under the take-up roller (11). When the unit is set to rewind operation, the amount of friction of this part will decrease to from 15 to 20 grams. Check to see whether this is satisfactory. If not, adjust the spring (12) and the pressure of the set sleeve (13).

4. FWD/REC CHANGING MECHANISM

Turning Record Playback Lever (N) to REC position causes Cam (a) to push Arm (b) as illustrated by the dotted lines in the figure. Arm (b) in turn pulls Rod (c) which causes Arms (d) and (e) to press Slide Switch SW-1 to recording position. If Arms (b), (d) and (e) do not work properly, SW-1 does not operate properly causing abnormal oscillation or the inability to record. Arms (b), (d), and (e) can be adjusted with screws (f) and (g).

V. HEAD ADJUSTMENTS

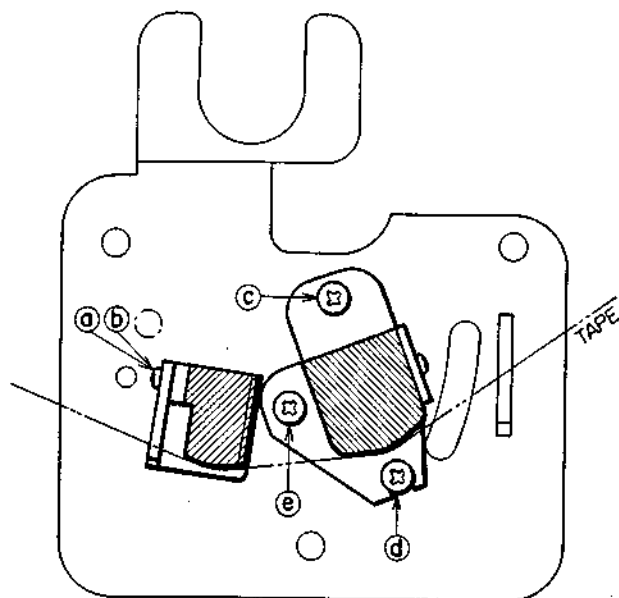

Fig. 10

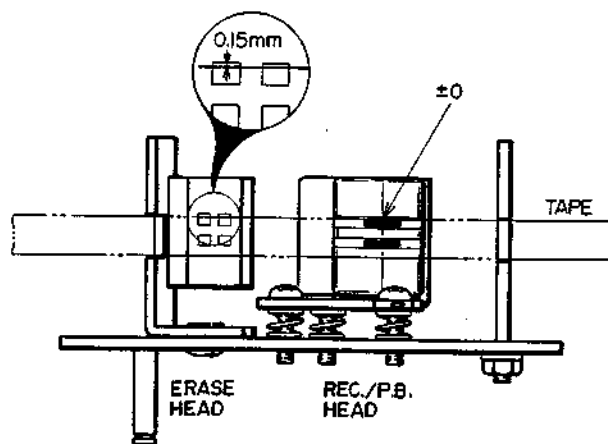

Fig. 11

Since adjustment of the Heads critically affects tape recorder performance, it is essential that Heads be carefully adjusted with precision measuring equipment.

1. HEAD HEIGHT ADJUSTMENTS

(See Figs. 10, 11)

a. Erase Head

Adjust the head height control screws (a) (b), so that the upper edge of the tape is 0.15 mm lower than the upper edge of the erase head core.

b. Recording/Playback Head

Adjust screws (c), (d) by turning to left and right until the width between the upper edge of channel 1 head core and the upper edge of the tape is equal.

2. HEAD SLANT ADJUSTMENT

(See Figs. 10, 11)

Adjust the screws (Head Height control screws) by turning to left and right so that the each head (Erase, Recording/Playback Head) contacts the tape surface at a right angle.

3. RECORDING/PLAYBACK HEAD AZIMUTH ALIGNMENT ADJUSTMENT

(See Figs. 10, 11)

Playback an Ampex Alignment test tape (8,000 Hz 3-3/4 ips) at 7-1/2 ips. Adjust screw (e) by turning to left and right until the various line outputs are maximum.

4. Repeat adjustment outlined in Items 1-b to 3 above, 2 or 3 times to obtain optimum adjusted condition.

VI. AMPLIFIER ADJUSTMENTS

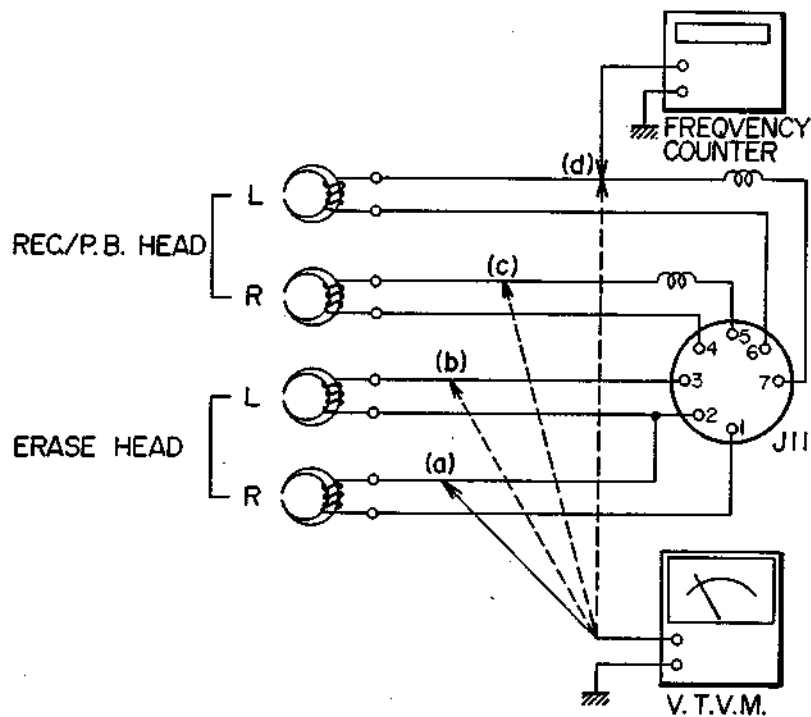

Fig. 12

1. RECORDING BIAS FREQUENCY ADJUSTMENT

- a. Set the recorder to "REC" mode.
- b. Connect a frequency counter to point (d) in Fig. 12 of the recording head and read the frequency indication.
- c. If the bias frequency is $63 \text{ kHz} \pm 8\%$, the bias frequency is correct.
- d. If the bias frequency is incorrect, it can be adjusted by changing the value of condenser C22 (5500 PF/500V) of the oscillator P.C. board (LS-5207).

2. RECORDING BIAS VOLTAGE (See Fig. 12)

Connect a V.T.V.M. to points (c), (d) and read the value of the V.T.V.M. The recording bias voltage is around 10V A.C. (31V A.C. for 1721W/L-H).

3. ERASE BIAS VOLTAGE (See Fig. 12)

Connect a V.T.V.M. to points (a), (b) and read the value of the V.T.V.M. The erase bias voltage is around 42V A.C. (27V A.C. for 1721W/L-H).

VII. COMPOSITE VIEWS OF COMPONENTS

PRE-AMP. P.C. BOARD (LS-5209) 1721W/L

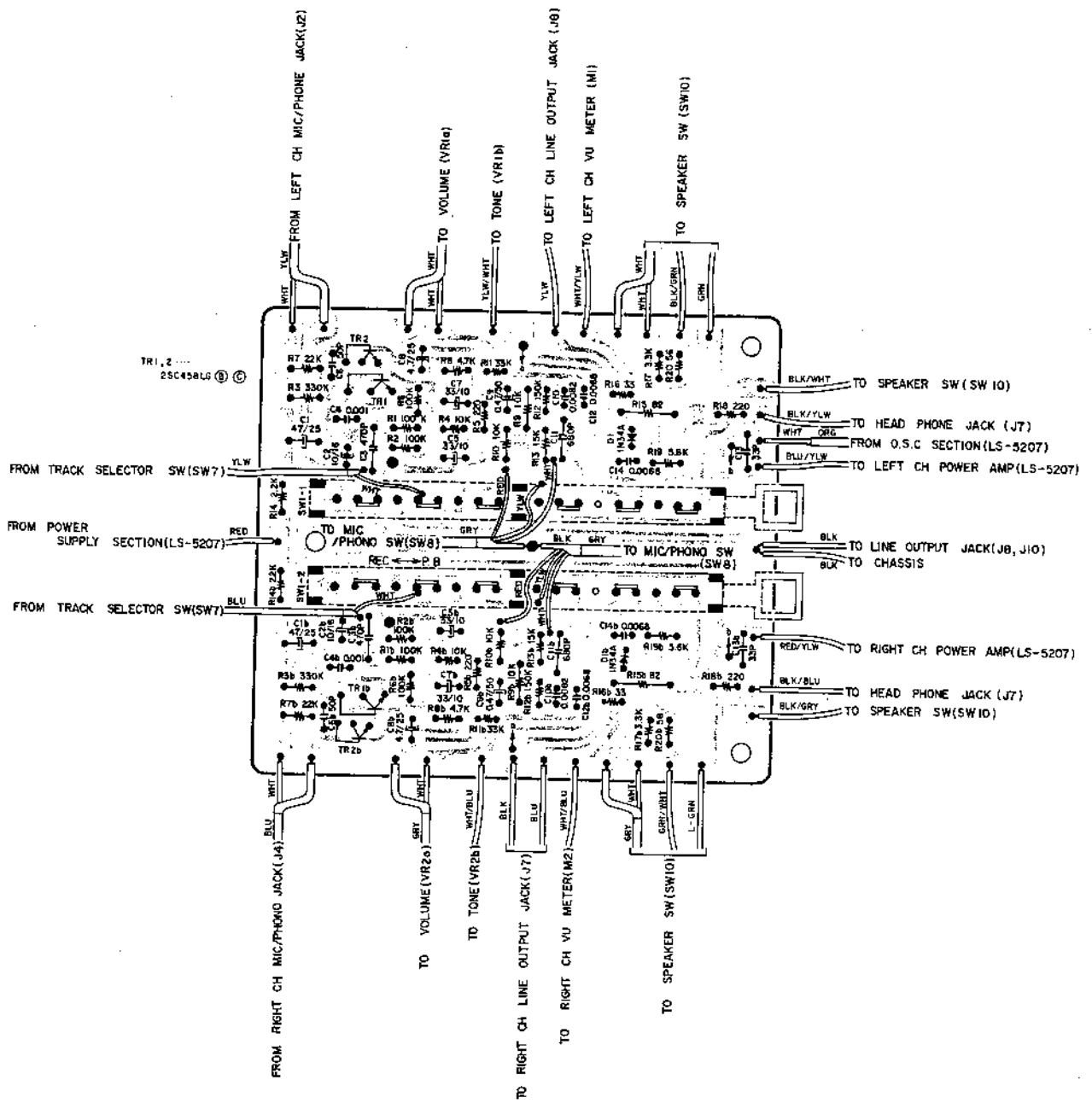

POWER SUPPLY P.C. BOARD (LS-5207) 1721W/L

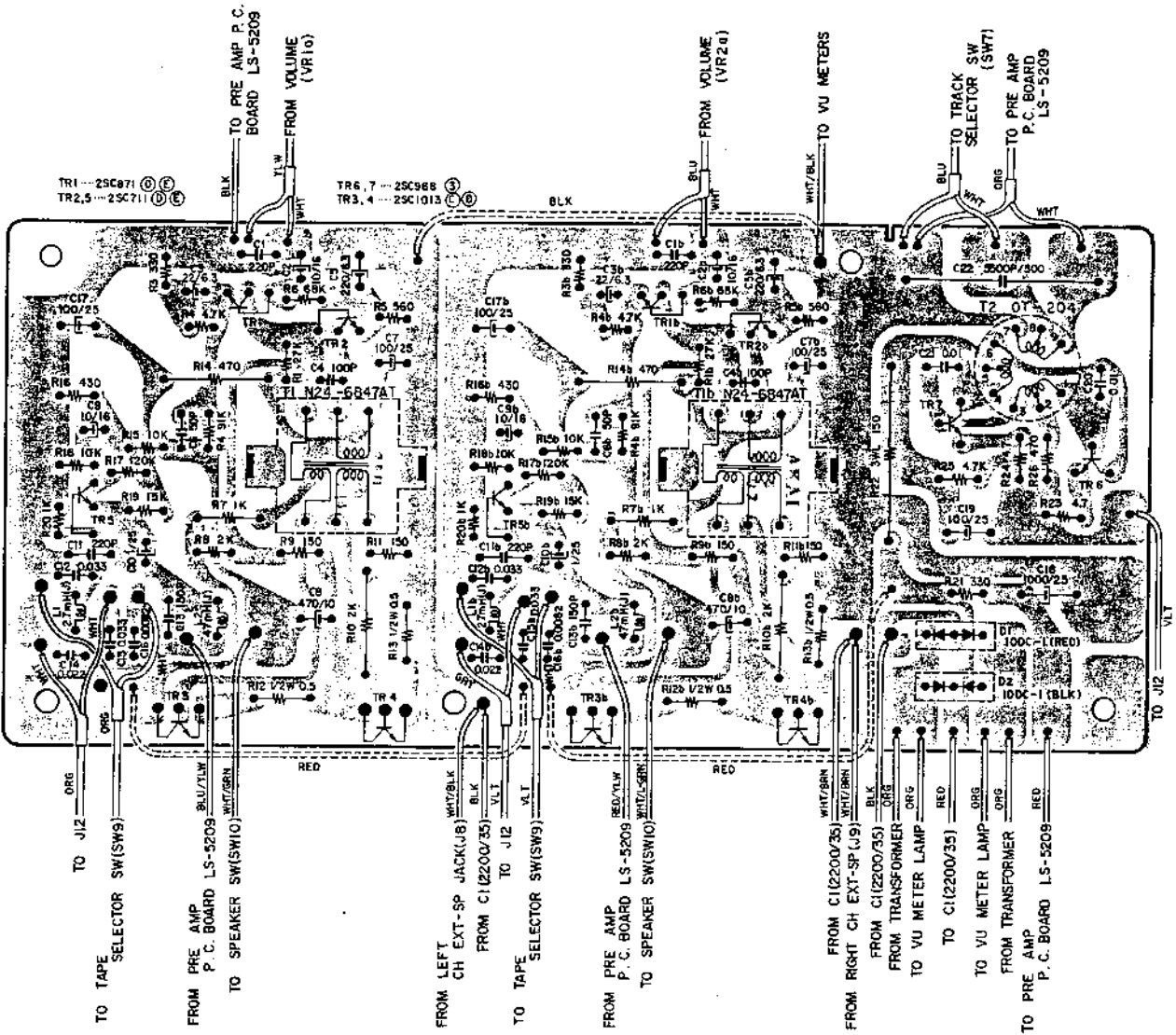

POWER SUPPLY P.C. BOARD (LS-5207) 1721W/L HALF TRACK

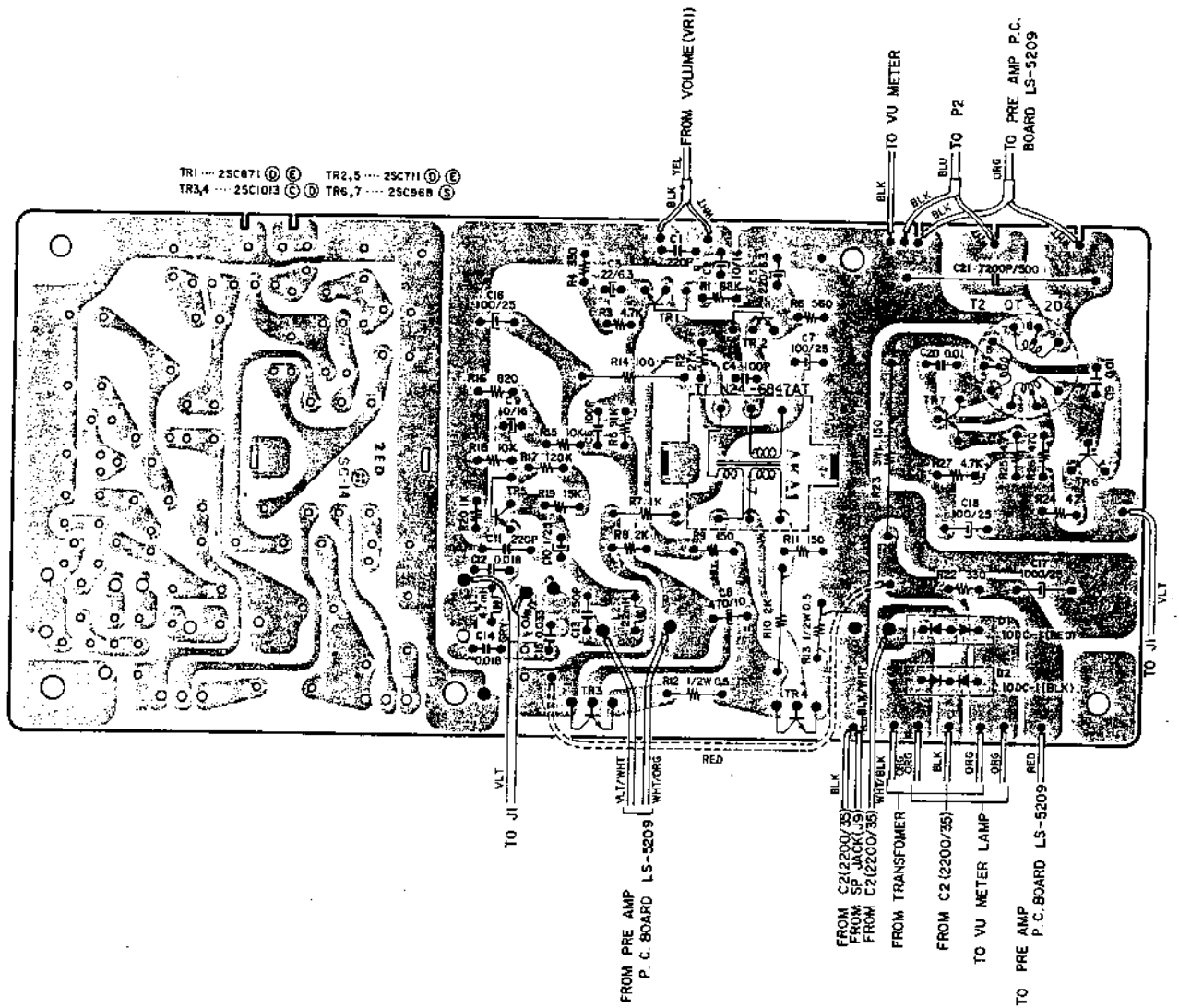

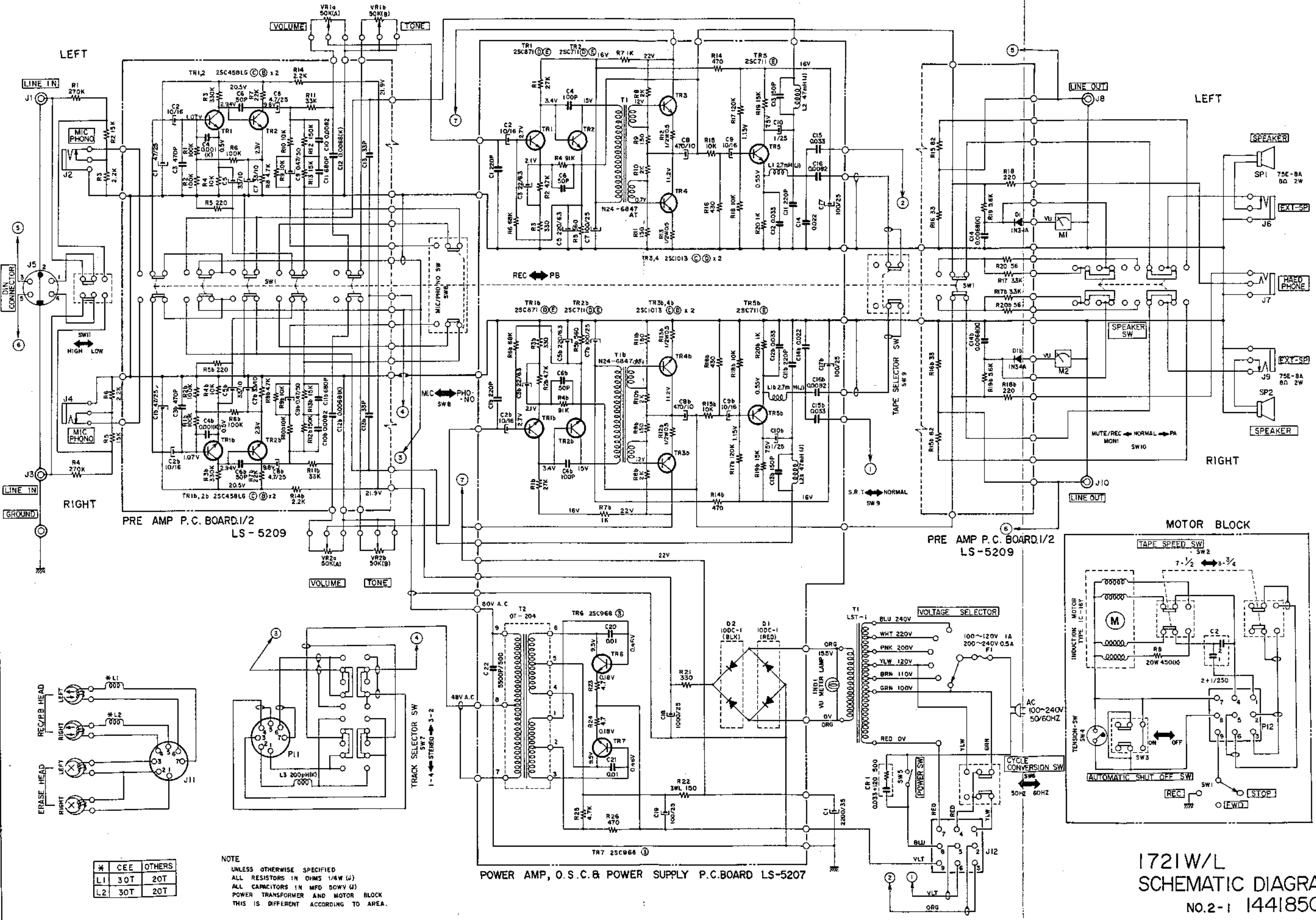

*	CEE	OTHERS
L1	30T	20T
L2	30T	20T

NOTE
 UNLESS OTHERWISE SPECIFIED
 ALL RESISTORS IN OHMS (1/4W (J))
 ALL CAPACITORS IN MFD (50WV (J))
 POWER TRANSFORMER AND MOTOR BLOCK
 THIS IS DIFFERENT ACCORDING TO AREA.

1721W/L
 SCHEMATIC DIAGRAM
 No.2-1 1441850A

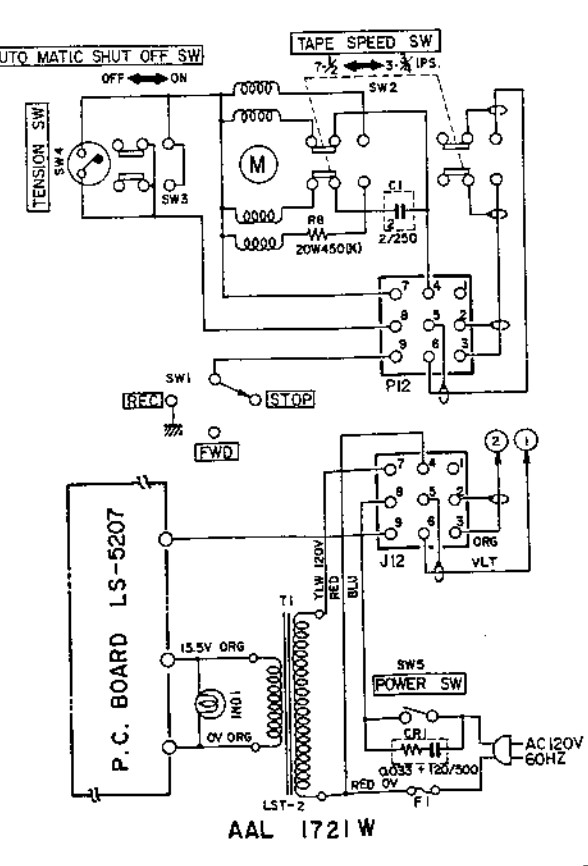
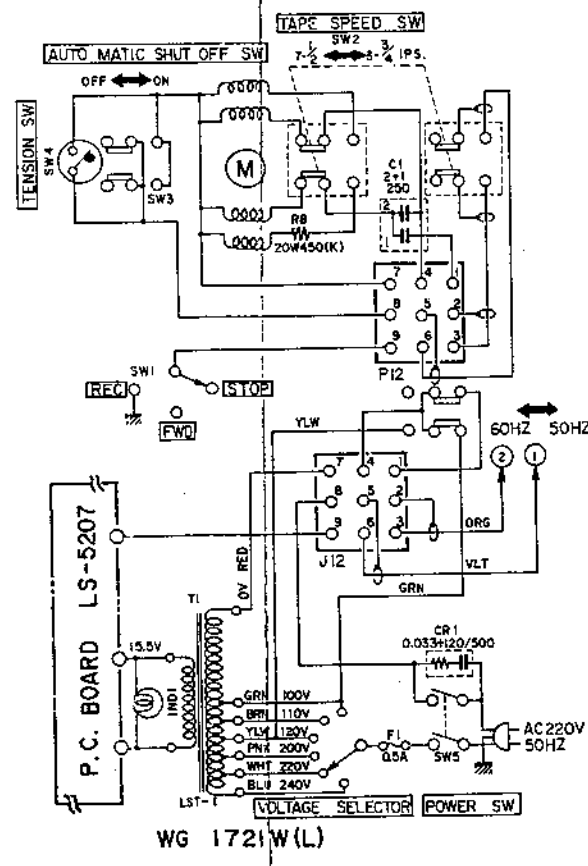
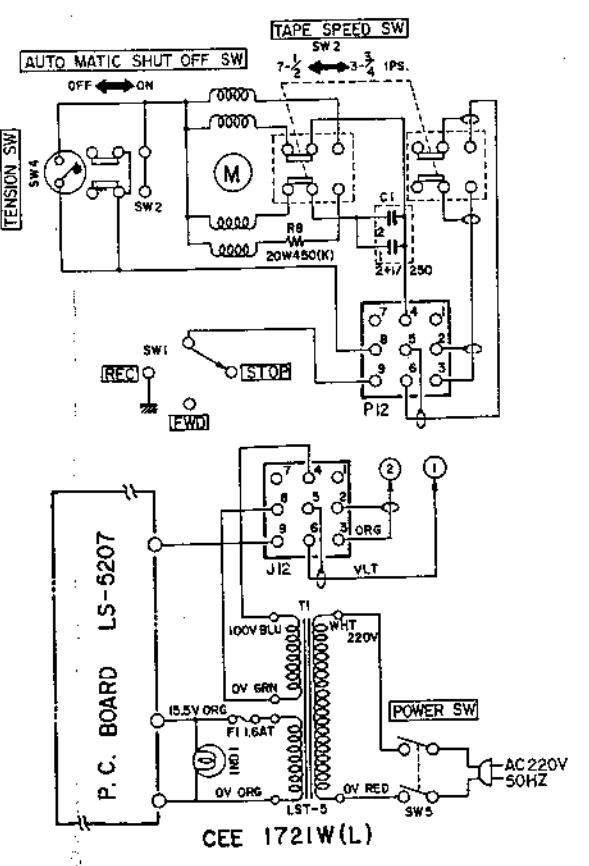
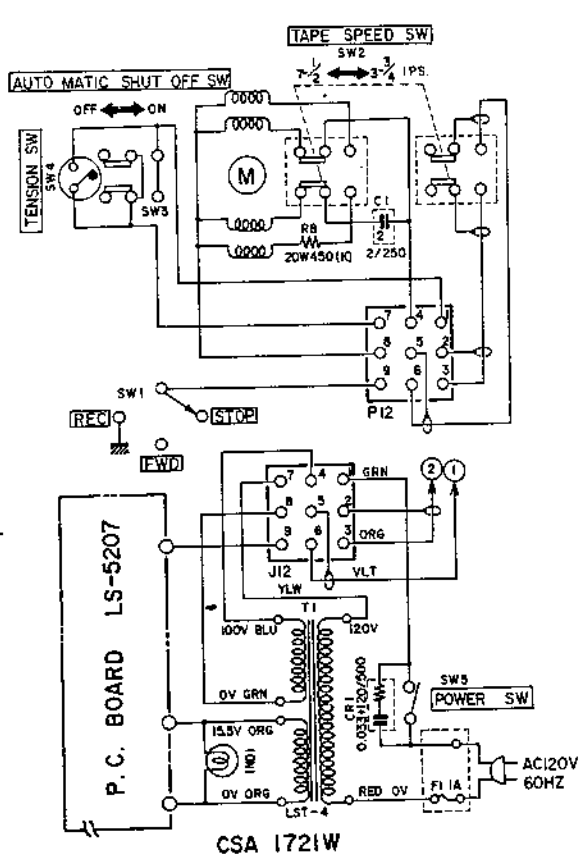
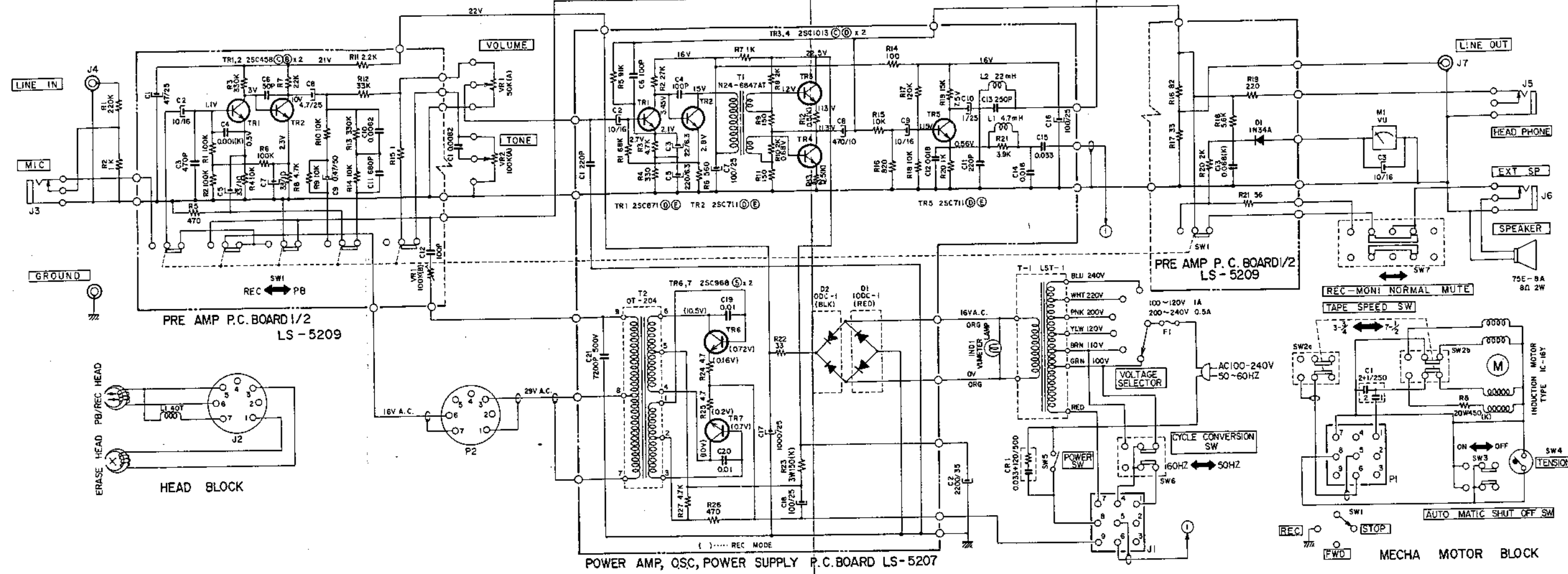

NOTE
UNLESS OTHERWISE SPECIFIED
ALL RESISTORS IN OHM (1/4W (J))
ALL CAPACITORS IN MFD 50WV (J)