

AKAI SERVICE MANUAL

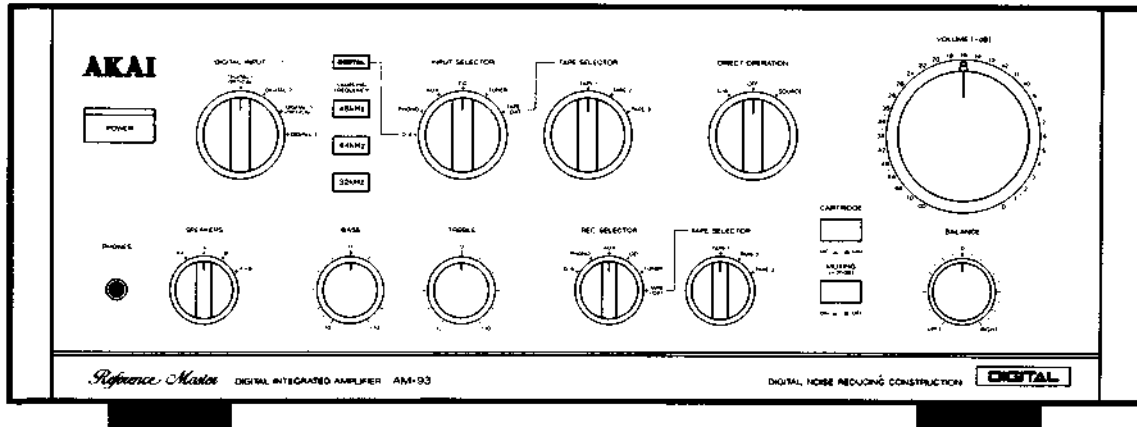

DIGITAL INTEGRATED AMPLIFIER

MODEL AM-93

SPECIFICATIONS

Power output.....	180 W + 180 W (DIN, 4 ohms) 130 W + 130 W (FTC, 8 ohms)	Channel separation.....	60 dB
Power band width.....	10 Hz to 60 kHz/0.1%	Audio mute	-20 dB
Total harmonic distortion	0.008% (1 kHz, 8 ohms)	Required speaker impedance	
Phone max. input level	200 mV (MM)	A or B	4 to 16 ohms
Frequency response	3 Hz to 100 kHz (+0 dB, -3 dB)	A and B.....	8 to 16 ohms
Tone control		Sampling frequency	32 kHz/44.1 kHz/48 kHz
TREBLE	±10 dB (10 kHz)	Digital filter	8 fs, 18 bit
BASS.....	±10 dB (100 Hz)	D/A converter	16 bit, 2 DAC
Input sensitivity/Impedance		Digital input level/Impedance	
PHONO (MM)	2.5 mV/47 kohms	COAXIAL	0.5 V _{p-p} /75 ohms
PHONO (MC).....	0.25 mV/100 ohms	OPTICAL	-14 to -23 dBm
TUNER, etc.	150 mV/47 kohms	Frequency response.....	5 Hz to 20 kHz (±0.3 dB)
Output level/Impedance		Dynamic range.....	95 dB
TAPE REC OUT....	150 mV/1 kohms	Total harmonic distortion.....	0.003%
Damping factor.....	30 (1 kHz)	Channel separation.....	115 dB
Residual noise	0.5 mV	Dimensions	461 (W) × 177 (H) × 452 (D) mm
S/N		Weight	20 kg (44 lbs)
PHONO (MM)	85 dB	Standard accessories	
PHONO (MC).....	67 dB	Operator's manual	1
TUNER, etc.	100 dB		

* For improvement purposes, specifications and design are subject to change without notice.

★ SAFETY INSTRUCTIONS

PRECAUTIONS DURING SERVICING

1. Parts identified by the Δ (*) symbol parts are critical for safety. Replace only with parts number specified.
2. In addition to safety, other parts and assemblies are specified for conformance with such regulations as those applying to spurious radiation. These must also be replaced only with specified replacements.
Examples: RF converters, tuner units, antenna selector switches, RF cables, noise blocking capacitors, noise blocking filters, etc.
3. Use specified internal wiring. Note especially:
 - 1) Wires covered with PVC tubing
 - 2) Double insulated wires
 - 3) High voltage leads
4. Use specified insulating materials for hazardous live parts. Note especially:
 - 1) Insulation Tape
 - 2) PVC tubing
 - 3) Spacers (Insulating Barriers)
 - 4) Insulation sheets for transistors
 - 5) Plastic screws for fixing microswitch (especially in turntable)
5. When replacing AC primary side components (transformers, power cords, noise blocking capacitors, etc.), wrap ends of wires securely about the terminals before soldering.
6. Observe that wires do not contact heat producing parts (heatsinks, oxide metal film resistors, fusible resistors, etc.).
7. Check that replaced wires do not contact sharp edged or pointed parts.
8. Also check areas surrounding repaired locations.
9. Use care that foreign objects (screws, solder droplets, etc.) do not remain inside the set.

SAFETY CHECK AFTER SERVICING

After servicing, make measurements of leakage-current or resistance in order to determine that exposed parts are acceptably insulated from the supply circuit.

The leakage-current measurement should be done between accessible metal parts (such as chassis, ground terminal, microphone jacks, signal-input/output connectors, etc.) and the earth ground through a resistor of 1500 ohms paralleled with a 0.15 μ F capacitor, under the unit's normal working conditions. The leakage-current should be less than 0.5 mA rms AC.

The resistance measurement should be done between accessible exposed metal parts and power cord plug prongs with the power switch (if included) "ON". The resistance should be more than 2.2 Mohms.



6. Observe that wires do not contact heat producing parts (heatsinks, oxide metal film resistors, fusible resistors, etc.).

★ INFORMATION

SYMBOLS FOR PRIMARY DESTINATION

Alphabet indicates the destination of the units as listed below.

Symbols	Principal Destinations
A	USA
B	UK
C	Canada
E	Europe (except UK)
J	Japan
S	Australia
V	W. Germany only
U	Universal Area
Y*	Custom version

VOLTAGE CONVERSION (U Model only)

Before connecting the power cord. Set the VOLTAGE SELECTOR located on the rear panel with a screwdriver so that the correct voltage is indicated.

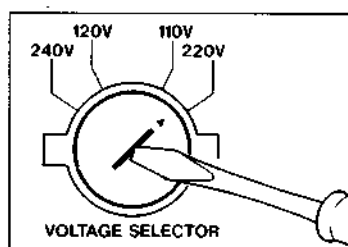

I. CONTROLS

1-1. FRONT PANEL

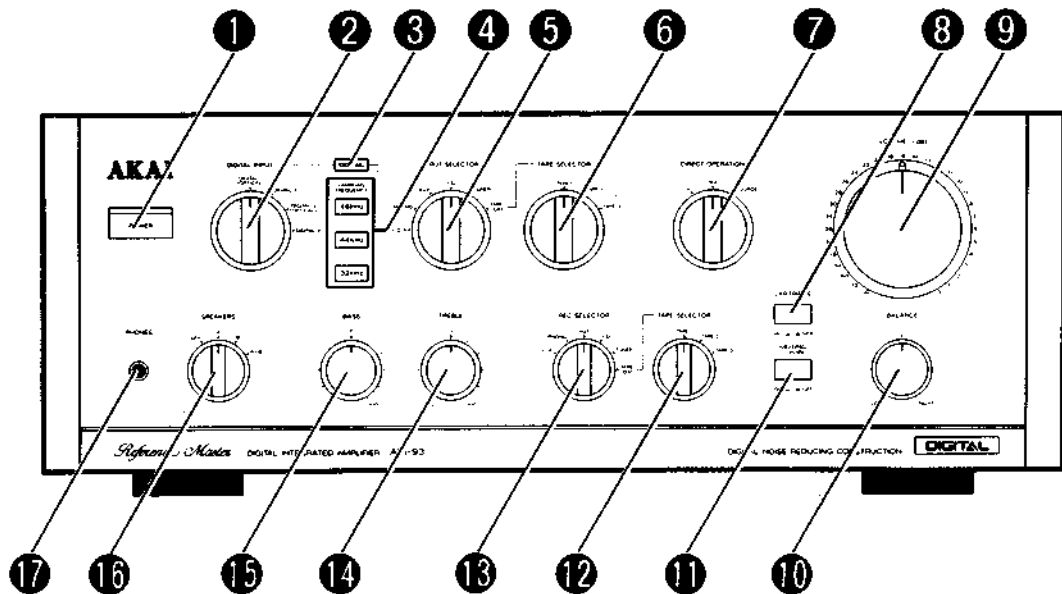

- ❶ POWER Button and Indicator**
To turn the power on and off. The indicator will flash on and off when the speaker protection circuit is engaged.
- ❷ DIGITAL INPUT Switch (DIGITAL 1 (OPTICAL), DIGITAL 2/3(OPTICAL)/4)**
To select the digital input source.
- ❸ DIGITAL Indicator**
Tells you the INPUT SELECTOR switch or the DIRECT OPERATION switch is set to D/A.
- ❹ SAMPLING FREQUENCY Indicators (32 kHz/44 kHz/48 kHz)**
Tells you the sampling frequency of the digital source being played back.
- ❺ INPUT SELECTOR Switch**
To select the playback source you wish to listen to.
- ❻ TAPE SELECTOR Switch**
To select the cassette deck or DAT deck being used for playback.
- ❼ DIRECT OPERATION Switch**
To select the playback operation mode. If you wish to use the BASS, TREBLE or BALANCE controls, set the switch to OFF.
- ❽ CARTRIDGE (— ON/ — OFF) Switch**
To set the phono amplifier's gain to high or low according to which type of cartridge (MC or MM) is being used with the connected turntable.
- ❾ VOLUME Control (—dB: minus decibel)**
To adjust the volume level. The 0 dB (zero decibel) position is the maximum volume output of the amplifier.
- ❿ BALANCE Control**
To adjust the left and right channel balance. Normally set the control to its center click position.
- ⓫ MUTING Switch (ON — /OFF —)**
To reduce the volume instantly during playback without using the VOLUME control.
- ⓬ TAPE SELECTOR Switch**
To select the cassette deck or DAT deck being used for recording.
- ⓭ REC SELECTOR Switch**
To select the playback source for recording.
- ⓮ TREBLE Tone Control**
To adjust the high note (treble) level. When set to 0, the control is ineffective.
- ⓯ BASS Tone Control**
To adjust the low note (bass) level. When set to 0, the control is ineffective.
- ⓰ SPEAKERS Switch**
To select the speaker system. For headphone listening, set the switch to OFF. When using two pairs of speaker systems at the same time, set the switch to A+B.
- ⓱ PHONES Jack**
For headphone listening. Connect the headphone plug to the jack.

1-2. REAR PANEL

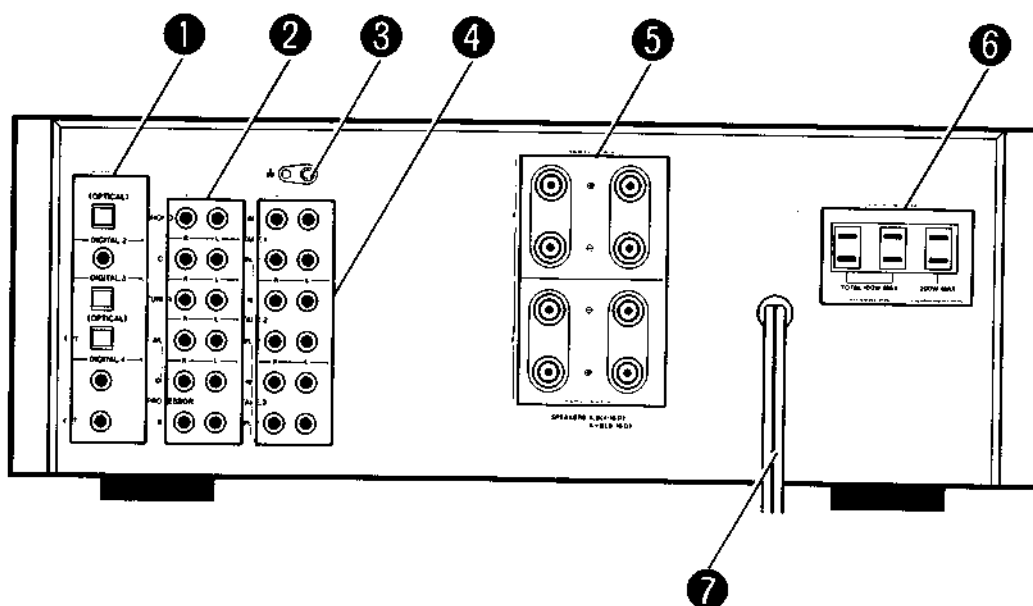

1 Digital Signal Connection Terminal and Jacks

For connection of components with DIGITAL INPUT or OUTPUT jacks.

DIGITAL.1 (OPTICAL) IN Terminal and terminal cap

Use this terminal when connecting a CD player or DAT deck that has an optical output terminal. (Use an optical fiber cable available in hi-fi stores for connections).

DIGITAL. 2 IN Jack

Use this jack when connecting a CD player or DAT deck that has a digital coaxial output jack. (Use a digital or video connection cable available in hi-fi stores for connections).

DIGITAL. 3 (OPTICAL) IN and OUT terminals and terminal caps.

DIGITAL. 4 IN and OUT Jacks
Use these jacks when connecting a DAT deck that has digital coaxial input and output jacks. (Use an optical, digital or video connection cable available in hi-fi stores for connections).

The DIGITAL OUT jack can be used for connection of a DAT deck for digital tape dubbing or a DSP (Digital Sound Processor).

2 Analog Connection Jacks

These jacks are for conventional signal (analog) connections. The white PIN-jacks are for left channel connections and the red PIN-jacks are for right channel connections.

PHONO Jacks

Connect the output PIN-plug cord of a turntable to these jacks.

CD Jacks

Connect the OUTPUT jacks of a CD player to these jacks with an audio PIN-plug cord.

TUNER Jacks

Connect the OUTPUT jacks of a tuner to these jacks with an audio PIN-plug cord.

AUX Jacks

Connect the OUTPUT jacks of an auxiliary source such as a cassette deck, DAT deck or CD player to these jacks with an audio PIN-plug cord.

PROCESSOR IN and OUT Jacks/Short pins

For connection of a graphic equalizer or surround processor with an audio PIN-plug cord.

Remove the two short pins from these jacks before connecting. Leave these pins in place when a graphic equalizer or surround processor is not connected to these jacks.

3 (Earth) Terminal

If your turntable has an earth wire, connect it to this terminal.

4 Analog Tape Connecting Jacks

For connection of cassette decks or DAT decks that have analog OUTPUT and INPUT jacks.

TAPE. 1, TAPE. 2 and TAPE. 3 Jacks (REC/PLAY)

Connect the INPUT jacks of a cassette deck or DAT deck to the REC jacks with an audio PIN-plug cord.

Connect the OUTPUT jacks of a cassette deck or DAT deck to the PLAY jacks with an audio PIN-plug cord.

5 SPEAKERS A, B Terminals

For speaker system connections. The A terminals correspond to the A position of the SPEAKERS switch and the B terminals correspond to the B position. Red terminals are the + (plus) terminals and black terminals are the - (minus) terminals.

6 AC OUTLETS (Not on all models)

For connection of audio equipment power cords (tuner, CD player, cassette deck, DAT deck etc.).

The maximum connected power consumption is 300 Watts. Do not exceed the maximum power consumption indicated on the rear panel of the amplifier.

The UNSWITCHED outlets supply power when the power cord of the amplifier is connected to a household AC outlet. The power to the SWITCHED outlet is turned on and off by the amplifier's POWER switch.

7 Power cord and plug

Connect to a household AC outlet. If you wish to use an audio timer, connect the power cord to the timer's AC outlet.

II. DISASSEMBLY

In case of trouble, etc. necessitating dismantling, please dismantle in the order shown in the photographs. Reassemble in reverse order.

1. Removal of UPPER COVER

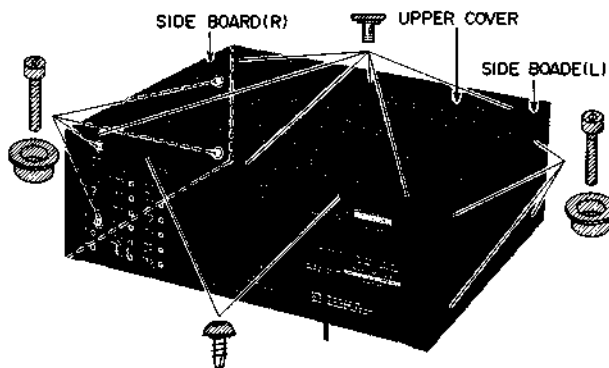

2. Removal of BOTTOM PLATE & FRONT PANEL

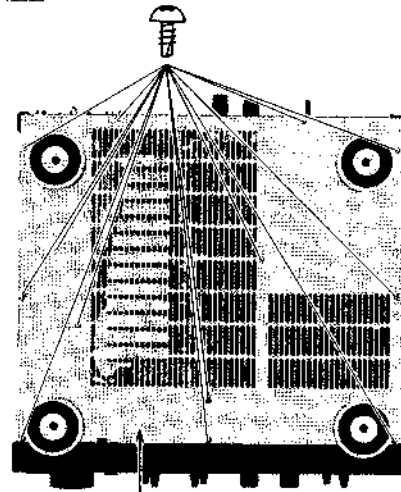

3.

CONNECTORS (J301, J302)

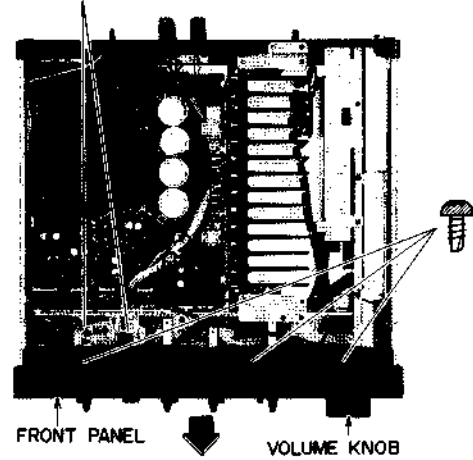

* Disconnect CONNECTORS (J301, J302) and remove VOLUME KNOB first, then remove FRONT PANEL next.

III. PRINCIPAL PARTS LOCATION

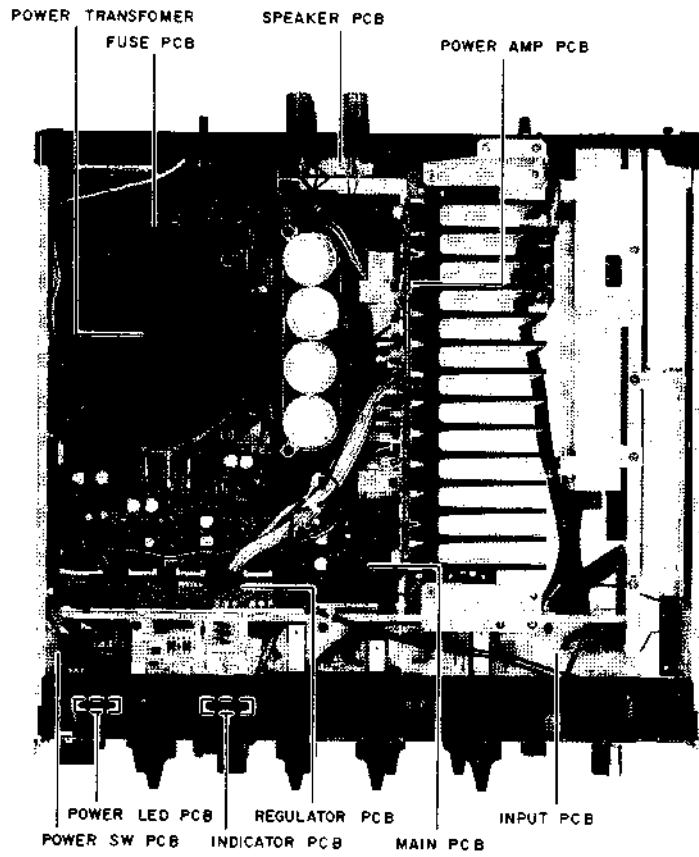

Fig. 3-1 Top View

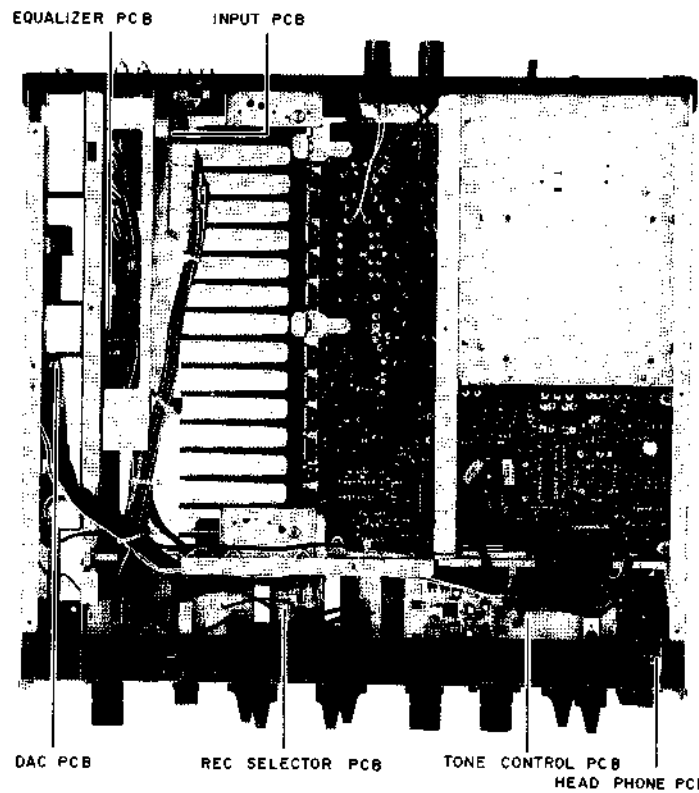

Fig. 3-2 Bottom View

IV. ELECTRICAL ADJUSTMENT

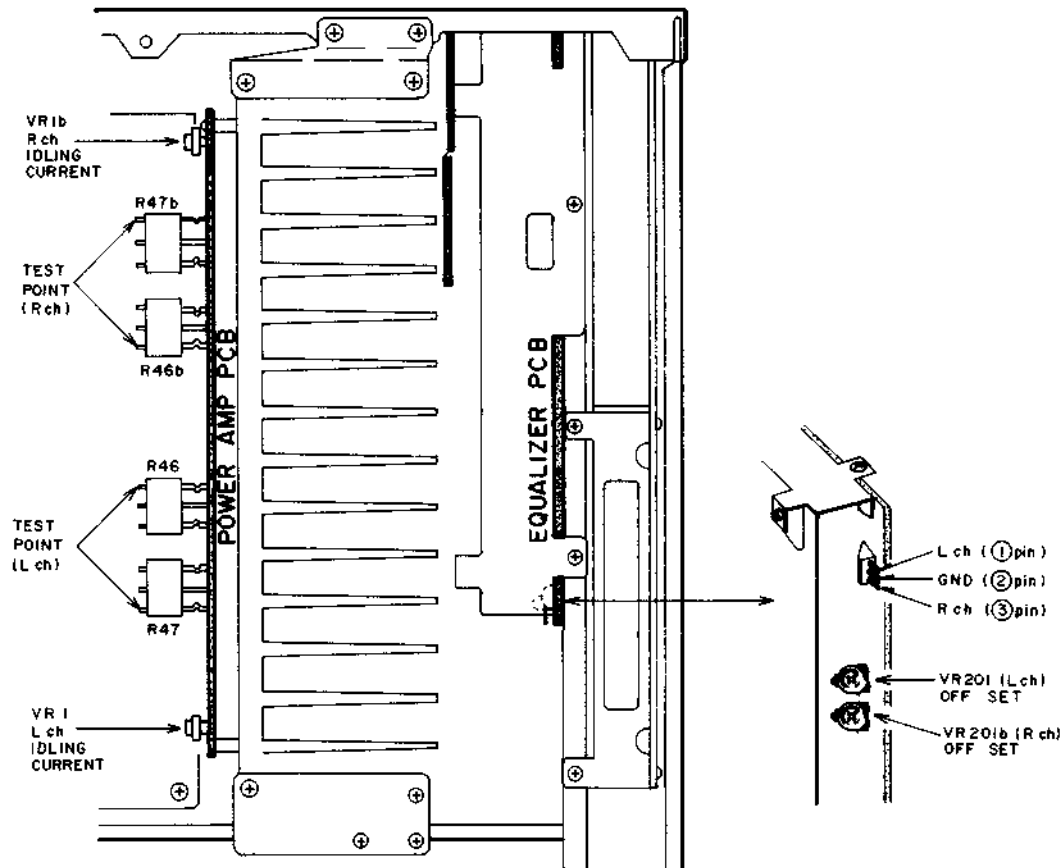

Fig. 4-1 Idling current OFF-SET adjustment parts and test points

4-1. IDLING CURRENT ADJUSTMENT (Refer to Fig. 4-1)

NOTE: This adjustment should be made immediately right after turning the power on.

- 1) Connect the digital DC voltmeter between both ends of cement type resistor R46 and R47 (L-CH), R46b and R47b (R-CH) on the POWER AMP PCB.
- 2) Adjust VR1 (L-CH), VR1b (R-CH) on the POWER AMP PCB so that the reading on the digital DC voltmis $20 \text{ mV} \pm 2 \text{ mV}$.

4-2. OFF-SET ADJUSTMENT OF PHONO AMPLIFIER (Refer to Fig. 4-1)

NOTE: This adjustment should be made after 5 minutes passed from turning the power on.

- 1) Connect the digital DC voltmeter between pin ①(L-CH) or pin ③(R-CH) and pin ②(GND) on the EQUALIZER PCB.
- 2) Set the selector switches on the front panel as follow.
INPUT SELECTOR: PHONO
CARTRIDGE: MC
- 3) Adjust VR201 (L-CH), VR201b (R-CH) on the EQUALIZER PCB, so that the reading on the digital DC voltmeter is 0 V.

4-3. DISTORTION ADJUSTMENT OF D/A CONVERTOR

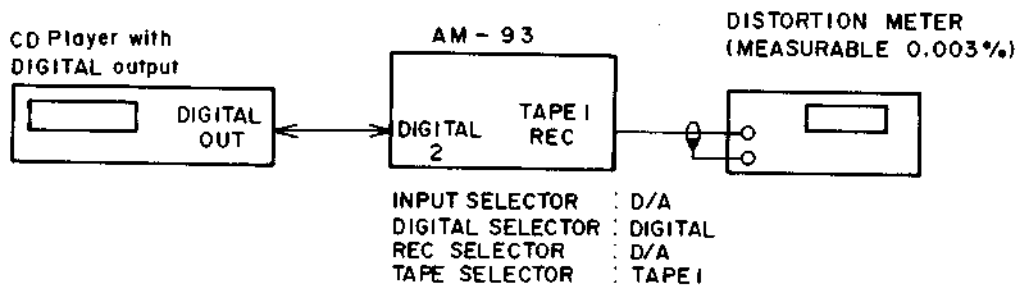

Fig. 4-2 Instrument connection

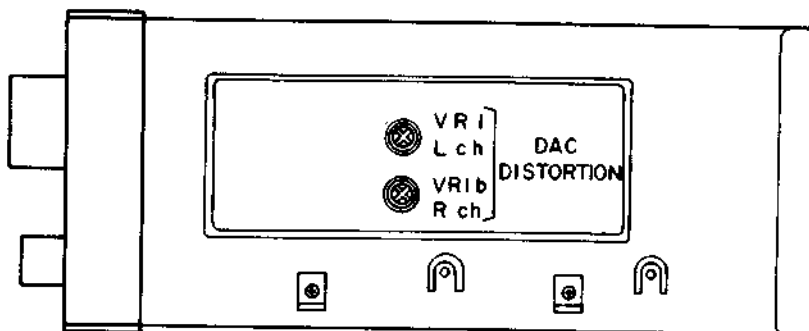

Fig. 4-3 Adjustment part of DAC PCB

- 1) Connect a CD player which has a digital output terminal to DIGITAL 2 IN, and connect distortion meter to TAPE 1 REC terminal.
- 2) Set the selector switches on the front panel as follow.

INPUT SELECTOR:	D/A
DIGITAL SELECTOR:	DIGITAL 2
REC SELECTOR:	D/A
TAPE SELECTOR:	TAPE 1
- 3) Insert a test disc TYPE III (AT-711881) into CD PLAYER and play it 1 kHz.
- 4) Adjust VR1 (L-CH), VR1b (R-CH) on the DAC PCB so that the reading on the distortion meter is at minimum (Less than 0.01%).

V. PARTS LIST

ATTENTION

1. When placing an order for parts, be sure to list Part No., Part No. and the description of each part. Otherwise, the availability of the part or the delivery of a wrong part may result.
2. Please make sure that Part No. is correct when ordering.
3. If not, a part different from the one you ordered may be supplied.
4. Since the parts shown in Parts List of Preliminary Service Manual may have been the subject of changes, please use this Parts List for all future reference.

HOW TO USE THIS PARTS LIST

1. This Parts List lists those parts which are considered necessary for repairs. Other common parts, such as resistors and capacitors, are listed in the "Common List for Service Parts" from which these parts should be selected and stocked.
2. The Recommended Spare Parts List shows those parts in the Parts List which are considered particularly important for service.
3. Parts not shown in the Parts List and "Common List for Service Parts" will not in principle be supplied.
4. How to read the Parts List.

a) Mechanism Block

2. HEAD BASE BLOCK

REF. NO.	PART NO.	DESCRIPTION
1	BH-T2023A320A	HEAD BASE BLOCK
2	HP-H2206A010A	HEAD R/P PR4-8FU C
3	ZS-477876	PAN20×03STL CMT
4	ZS-536488	BID20×08STL CMT
5	ZG-402895	SP CS ANGLE ADJUST

SP (Service Parts) Classification

This number corresponds with the individual parts index number in that figure.

b) PC Board

6. MAIN PC BOARD

REF. NO.	PART NO.	DESCRIPTION
IC1	EI-324536	IC HD14049BP
IC2	EI-336801	IC MB8841-564M
C1A	EC-338399	C MMY V 223M 250AC [U,E,B,S]
C1B	EC-350949	C MMY V 223M 250DC [J]
C1C	EC-338397	C MMY V 223M 125AC [C,A]
X1	EI-318384	OSC XTAL NC-18C

Symbols for primary destination

[A]: AAL (U.S.A) [S]: SAA (Australia)
 [B]: BEAB (England) [U]: U/T (Uni-versa Area)
 [C]: CSA (Canada) [V]: VDE (W. Germany)
 [J]: JPN (Japan) [Y]: Custom Version

SP (Service Parts) Classification

These reference symbols correspond with component symbols in the Schematic Diagrams.

The available PC Board Blocks are listed separately.

5. When Part No. is known, Parts Index at end of Parts List can be used to locate where that part is shown in Parts List by its Reference No. listed at right of Part No.

WARNING

⚠(*) INDICATES SAFETY CRITICAL COMPONENTS. FOR CONTINUED SAFETY, REPLACE SAFETY CRITICAL COMPONENTS ONLY WITH MANUFACTURER'S RECOMMENDED PARTS.

AVERTISSEMENT

⚠(*) IL INDIQUE LES COMPOSANTS CRITIQUES DE SECURITE. POUR MAINTENIR LE DEGRE DE SECURITE DE L'APPAREIL, NE REMPLACER QUE DES PIECES RECOMMANDEES PAR LE FABRICANT.

1. RECOMMENDED SPARE PARTS

We suggest you to stock the following Recommended Spare Part items listed below since they can cover most of the routine service.

Ref. No.	Part No.	Description
1	*BT-385573J	TRANS POW A2050(B) [B]
2	*BT-385570J	TRANS POW A2050(C,A) [C,A]
3	*BT-385572J	TRANS POW A2050(EV) [E,V]
4	*BT-385569J	TRANS POW A2050(U) [U]
5	BT-368261	TRANS PULSE TC-1027-04
6	ED-382620J	D LED PG5562X GREEN [DIGITAL]
7	ED-382611J	D LED PY5504S YELLOW
8	ED-361885	D LED SLP-384C-51 GREEN [POWER]
9	ED-383034J	D LED SLR-54PC3F L,M GREEN
10	*ED-379981J	D SILICON EG01LF-F4 F10 400/0.7A
11	ED-348990	D SILICON H DS446
12	ED-301911	D SILICON H DS448
13	ED-385575J	D SILICON H 1SS182FA F10
14	*ED-382668J	D SILICON PB-112F
15	ED-346560	D ZENER H HZ12B3L
16	ED-346564	D ZENER H HZ15-1L
17	ED-346570	D ZENER H HZ18-3L
18	ED-377933	D ZENER H HZ27-3LFA F10
19	ED-381270J	D ZENER H HZ33-1LFA F10
20	ED-343410	D ZENER H HZ6A1L
21	ED-346529	D ZENER H HZ6C2L
22	ED-351418	D ZENER H HZ7B1L
23	*EF-355226	FUSE BET T 250V 1.00A [B]
24	*EF-355399	FUSE BET T 250V 5.00A [B]
25	*EF-623103	FUSE SEMKO T 250V 1.00A [E,V]
26	*EF-242605	FUSE SEMKO T 250V 6.30A [E,V]
27	*EF-327103	FUSE TSC A 250V 500MA [U]
28	*EF-341260	FUSE TSC A 250V 8.00A [U]
29	*EF-309388	FUSE TSC A 250V 800MA [U]
30	*EF-385542J	FUSE TSC 125V 10.00A [C,A]
31	*EF-309390	FUSE TSC 125V 500MA [C,A]
32	*EF-309391	FUSE TSC 125V 800MA [C,A]
33	EH-383070J	FILTER EMI BL01RN1-A62
34	EI-345474	IC HA12002
35	EI-375346	IC MM74HCO4N
36	EI-344764	IC M5218P-21
37	EI-362587	IC M5238L
38	EI-362588	IC M5238P
39	EI-377191	IC NJM5632D-D
40	EI-368612	IC PCM56P
41	EI-360040	IC TC74HCU04P
42	EI-360037	IC TC74HC00P
43	EI-358049	IC TC74HC139P
44	EI-378921J	IC TC74HC151P
45	EI-386485J	IC YM3414
46	EI-379997J	IC YM3623B
47	EI-382925J	OSC XTAL NR-18 19.200MHZ
48	EQ-379982J	RELAY POW G5R-2282P 2NO 48V
49	EQ-348929	RELAY SIG G5A-237P 2TR 12V
50	*ER-338000	R FUSE H S10 ERD2FC 1/4W 2200G
51	*ES-355407	SW PUSH ESB-99713V TV-8 [POWER SW]
52	ES-378941J	SW PUSH SPUL12 2-04-02S [MUTE]

Ref. No.	Part No.	Description
53	ES-385552J	SW REMOTE S SSSR24 [CARTRIDGE MC/MM]
54	ES-379984J	SW ROTARY SRRZS4 2-04-04N [DIGITAL INPUT]
55	ES-379986J	SW ROTARY SRRZS6 2-06-06N [INPUT SELECTOR]
56	ES-379988J	SW ROTARY SRRZS8 2-08-03N [DIRECT OPERATION]
57	ET-360646	TR DTA143ES
58	ET-354371	TR DTC124ES
59	ET-364060	TR DTC143ES
60	ET-357162	TR FET 2SJ74 GR,BL,V
61	ET-354897	TR FET 2SK170 BL,GR,V
62	*ET-359827	TR FET 2SK246 BL
63	ET-308472	TR 2SA1115 E,F,G F05
64	ET-338244	TR 2SA1207 R,S
65	ET-345460	TR 2SA1208 R,S,T
66	ET-348829	TR 2SA1209 S,T
67	*ET-345626	TR 2SA1248 S,T
68	*ET-385577J	TR 2SA1306 Y
69	ET-352726	TR 2SA1392 T,U
70	*ET-368757	TR 2SA1490 P,Y
71	*ET-385561J	TR 2SA1492 P,Y
72	ET-354601	TR 2SB941 P,Q
73	ET-308141	TR 2SC2603 G F05
74	ET-348830	TR 2SC2909 S,T
75	ET-370038	TR 2SC2910 S,T
76	*ET-345625	TR 2SC3116 S,T
77	*ET-385557J	TR 2SC3298Y
78	ET-360067	TR 2SC3330 T,U F05
79	ET-349081	TR 2SC3383 S,T
80	*ET-368759	TR 2SC3854 P,Y
81	*ET-385559J	TR 2SC3856 P,Y
82	ET-371028	TR 2SD1266 P,Q
83	*ET-349459	TR 2SD1406 O,Y,GR
84	EV-379987J	SW ROTARY SRRZS6 2-06-03N [TAPE SELECTOR]
85	EV-379994J	VR ROTARY RK1631110 SPL W104 [BALANCE]
86	EV-379992J	VR ROTARY RK1631210 C104X2 [BASS CONTROL]
87	EV-379993J	VR ROTARY RK1631210 C104X2 [TREBLE CONTROL]
88	EV-379989J	VR ROTARY RK16314A0 A104X4 [MAIN VOLUME][FORMER]
89	EV-387948J	VR ROTARY RK18114A0 A104X4 [MAIN VOLUME][NEW]

10. POWER AMP P.C BOARD

Ref. No.	Part No.	Description
C1	EC-377960	C PP V F05 CSF3 101J 125DC
C3	EC-381267J	C PP V F05 CSF3 473J 125DC
C4	EC-381267J	C PP V F05 CSF3 473J 125DC
C5	EC-382572J	C PC MKC1862 334K 100DC
C10	EC-347375	C MC V F05 FE92 220J 500DC
C11	EC-347375	C MC V F05 FE92 220J 500DC
D1	ED-385575J	D SILICON H 1SS182FA F10
D2	ED-385575J	D SILICON H 1SS182FA F10
FL101	EH-383070J	FILTER EMI BL01RN1-A62
FL102	EH-383070J	FILTER EMI BL01RN1-A62
FL103	EH-383070J	FILTER EMI BL01RN1-A62
FL104	EH-383070J	FILTER EMI BL01RN1-A62
IC1	EI-362587	IC M5238L
R35	ER-378846J	R CB H S10 FS RDS 1/4W 102J
R37	ER-372991	R CB H S10 FS RDS 1/4W 101J
R38	ER-372991	R CB H S10 FS RDS 1/4W 101J
R39	ER-324186	R CB H S10 FS RDS 1/4W 681J
R40	ER-383007J	R OMF H S12 FS 1W 1R0J
R41	ER-383007J	R OMF H S12 FS 1W 1R0J
R42	ER-383007J	R OMF H S12 FS 1W 1R0J
R43	ER-383007J	R OMF H S12 FS 1W 1R0J
R44	ER-355214	R OMF H S15 FS 2W 151J
R46	ER-368226	R CT P R33+R33 5W
R47	ER-368226	R CT P R33+R33 5W
TR1	ET-354897	TR FET 2SK170 BL,GR,V
TR2	ET-357162	TR FET 2SJ74 GR,BL,V
TR3	ET-348830	TR 2SC2909 S,T
TR4	ET-338244	TR 2SA1207 R,S
TR5	ET-338244	TR 2SA1207 R,S
TR6	ET-348830	TR 2SC2909 S,T
TR7	ET-338244	TR 2SA1207 R,S
TR8	ET-338244	TR 2SA1207 R,S
TR9	ET-348830	TR 2SC2909 S,T
TR10	ET-348830	TR 2SC2909 S,T
TR11	ET-306141	TR 2SC2603 G F05
TR12	ET-348829	TR 2SA1209 S,T
TR13	ET-370038	TR 2SC2910 S,T
TR14	ET-345460	TR 2SA1208 R,S,T
TR15	*ET-385557J	TR 2SC3298 Y
TR16	*ET-385577J	TR 2SA1306 Y
TR17	*ET-385559J	TR 2SC3856 P,Y
TR18	*ET-385559J	TR 2SC3856 P,Y
TR19	*ET-385561J	TR 2SA1492 P,Y
TR20	*ET-385561J	TR 2SA1492 P,Y
VR1	EV-330369	R S-FIX H RH1051C 0.15W 222

11. FUSE P.C BOARD

Ref. No.	Part No.	Description
L301	EO-332116	COIL FIX 2 103AK-006A 2R2K
F1A	*EF-341260	FUSE TSC A 250V 8.00A [U]
F1B	*EF-385542J	FUSE TSC 125V 10.00A [C,A]
F1C	*EF-242605	FUSE SEMKO T 250V 6.30A [E,V]
F1D	*EF-355399	FUSE BET T 250V 5.00A [B]
F2	*EF-341260	FUSE TSC A 250V 8.00A [U]

12. POWER SW P.C BOARD

Ref. No.	Part No.	Description
C401A	*EC-320548	C CE V F 103Z 250AC [U]
C401B	*EC-338496	C CE V FZ 472P 400AC [C,A,E,B]
C401C	*EH-386991J	SPARK QUENCHER XE120033 [V]
SW1	*ES-355407	SW PUSH ESB-99713V TV-8 [POWER SW]

13. EQUALIZER P.C BOARD

Ref. No.	Part No.	Description
C150	EC-347408	C MC V F05 FE92 101J 500DC
C201	EC-382572J	C PC MKC1862 334K 100DC
C202	EC-381267J	C PP V F05 CSF3 473J 125DC
C203	EC-381267J	C PP V F05 CSF3 473J 125DC
D101	ED-301911	D SILICON H DS448
D102	ED-301911	D SILICON H DS448
D301	ED-346570	D ZENER H HZ18-3L
D302	ED-346570	D ZENER H HZ18-3L
FL101	EH-383070J	FILTER EMI BL01RN1-A62
FL102	EH-383070J	FILTER EMI BL01RN1-A62
IC201	EI-362588	IC M5238P
J101	EJ-336904	PIN J AJC-036ACB P 6P [PHONE,CD,TUNER]
J102	EJ-336904	PIN J AJC-036ACB P 6P [AUX,PROCESSOR IN/OUT]
L101	EO-353587	COIL FIX 1 LAP02 F05 220K
L102	EO-353587	COIL FIX 1 LAP02 F05 220K
R127	ER-382604J	R CB H S10 FS RDS 1/4W 390J
R128	ER-382604J	R CB H S10 FS RDS 1/4W 390J
R301	*ER-338000	R FUSE H S10 ERD2FC 1/4W 2200G
R302	*ER-338000	R FUSE H S10 ERD2FC 1/4W 2200G
SW101	ES-385552J	SW REMOTE S SSSR24 [CARTRIDGE MC/MM]
TR101	ET-354897	TR FET 2SK170 BL,GR,V
TR102	ET-357162	TR FET 2SJ74 GR,BL,V
TR103	ET-352726	TR 2SA1392 T,U
TR104	ET-349081	TR 2SC3383 S,T
TR105	ET-349081	TR 2SC3383 S,T
TR106	ET-349081	TR 2SC3383 S,T
TR201	ET-308472	TR 2SA1115 EF,G F05
TR202	ET-308141	TR 2SC2603 G F05
TR301	ET-371028	TR 2SD1266 P,Q
TR302	ET-354601	TR 2SB941 P,Q
VR201	EV-347942	R S-FIX V RVF8W01 0.10 502

14. INPUT P.C BOARD

Ref. No.	Part No.	Description
D1	ED-343410	D ZENER H HZ6A1L
SW301	ES-379986J	SW ROTARY SRRZS6 2-06-06N [INPUT SELECTOR]
SW302	EV-379987J	SW ROTARY SRRZS6 2-06-03N [TAPE SELECTOR]
SW303	ES-379988J	SW ROTARY SRRZS8 2-08-03N [DIRECT OPERATION]
SW304	ES-379984J	SW ROTARY SRRZS4 2-04-04N [DIGITAL INPUT]
TR1	ET-360646	TR DTA143ES
TR2	ET-360646	TR DTA143ES
TR3	ET-360646	TR DTA143ES
VR1	EV-379989J	VR ROTARY RK16314A A104X4 [MAIN VOLUME][FORMER]
VR1Z	EV-387949J	VR ROTARY RK18114A A104X4 [MAIN VOLUME][NEW]

15. TONE CONTROL P.C BOARD

Ref. No.	Part No.	Description
C101	EC-377960	C PP V F05 CSF3 101J 25DC
IC1	EI-344764	IC M5218P-21
SW1	ES-379984J	SW ROTARY SRRZS4 2-04-04N [SPEAKER SELECTOR]
VR1	EV-379992J	VR ROTARY RK1631211 C 104X2 [BASS CONTROL]
VR2	EV-379993J	VR ROTARY RK1631211 C 104X2 [TREBLE CONTROL]

16. REC SELECTOR P.C BOARD

Ref. No.	Part No.	Description
D1	ED-301911	D SILICON H DS448
SW1	ES-379986J	SW ROTARY SRRZS6 2-06-06N [REC SELECTOR]
SW2	ES-379988J	SW ROTARY SRRZS8 2-08-03N [TAPE SELECTOR]
SW3	ES-378941J	SW PUSH SPUL12 2-04-02S [MUTE]
VR1	EV-379994J	VR ROTARY RK1631110 SPL W104 [BALANCE]

17. DAC P.C BOARD

Ref. No.	Part No.	Description
C29	EC-380325J	C PP V MKP1841 104J 250DC
C33	EC-378457	C PP V F05 CSF3 681J 125DC
C34	EC-378457	C PP V F05 CSF3 681J 125DC
C36	EC-368036	C PP V F05 CSF3 103J 125DC
D1	ED-301911	D SILICON H DS448
D2	ED-301911	D SILICON H DS448
D3	ED-301911	D SILICON H DS448
D4	ED-301911	D SILICON H DS448
D5	ED-301911	D SILICON H DS448
FL1	EO-378920J	COIL VARI 1 25-5721-13
IC3	EI-360040	IC TC74HCU04P
IC4	EI-378921J	IC TC74HC151P
IC5	EI-360037	IC TC74HC00P
IC6	EI-360040	IC TC74HCU04P
IC7	EI-375346	IC MM74HCO4N
IC9	EI-379997J	IC YM3623B
IC10	EI-386485J	IC YM3414
IC11	EI-356049	IC TC74HC139P
IC12	EI-368612	IC PCM56P
IC13	EI-377191	IC NJM5532D-D
J3	EJ-377170	PIN J YKB11-0473 GP ORANGE 1P [DIGITAL 2 IN]
J4	EJ-377170	PIN J YKB11-0473 GP ORANGE 1P [DIGITAL 4 IN]
J5	EJ-377170	PIN J YKB11-0473 GP ORANGE 1P [DIGITAL 4 OUT]
J6	EJ-385272J	SOCKET OPTICAL TORX174 [DIGITAL 1 IN]
J7	EJ-385272J	SOCKET OPTICAL TORX174 [DIGITAL]
J8	EJ-383549J	SOCKET OPTICAL TORX174 [DIGITAL 3 OUT]
L1	EO-345913	COIL FIX 1 LAL03KH 100K
L2	EO-318379	COIL FIX 1 LAL04 101K
L3	EO-345909	COIL FIX 1 LAL03KH 4R7K
L4	EO-345909	COIL FIX 1 LAL03KH 4R7K
L5	EO-345909	COIL FIX 1 LAL03KH 4R7K
L6	EO-345909	COIL FIX 1 LAL03KH 4R7K
L7	EO-345909	COIL FIX 1 LAL03KH 4R7K
L8	EO-345909	COIL FIX 1 LAL03KH 4R7K
L9	EO-345909	COIL FIX 1 LAL03KH 4R7K
L10	EO-345909	COIL FIX 1 LAL03KH 4R7K
L11	EO-345909	COIL FIX 1 LAL03KH 4R7K
L12	EO-345909	COIL FIX 1 LAL03KH 4R7K
L13	EO-345909	COIL FIX 1 LAL03KH 4R7K
L14	EO-345922	COIL FIX 1 LAL03KH 470K
L15	EO-345922	COIL FIX 1 LAL03KH 470K
TR1	ET-354371	TR DTC124ES
TR2	ET-352726	TR 2SA1392 T,U
TR3	ET-354371	TR DTC124ES
TR4	ET-352726	TR 2SA1392 T,U
TR5	ET-349081	TR 2SC3383 S,T
TR6	ET-349081	TR 2SC3383 S,T
TR7	ET-364060	TR DTC143ES
T1	BT-368261	TRANS PULSE TC-1027-04
VR1	EV-337996	R S-FIX H RVF8P01 0.10W 104
X1	EI-382925J	OSC X-TAL NR-18 19.200MHZ

18. FINALASSEMBLY BLOCK

Ref. No.	Part No.	Description
5A	SP-379915J	PANEL REAR AM-93(U) [U]
5B	SP-379916J	PANEL REAR AM-93(A,C) [C,A]
5C	SP-379917J1	PANEL REAR AM-93(E,V) [E,V]
5D	SP-379918J1	PANEL REAR AM-93(B) [B]
6A	*EJ-337405	SOCKET OUT S2T733T164 JUC 3X2P [U]
6B	*EJ-352642	SOCKET OUTLET S2T733T114T [C,A]
7A	*EW-363658	AC CORD 200 0129AVFF B100 A U/ [U]
7B	*EW-363646	AC CORD 200 238APSPT2 B100 A U [C,A]
7C	*EW-363671	AC CORD 200 0364 LCFL B100 A E [E,V]
7D	*EW-363683	AC CORD 200 LCFL B100 A B [B]
8	*ES-349070	SW SELECTOR YKS11-0002 02-4 [U]
9	EJ-329610	TERMINAL W/SCREW UB-0067 L 1P
10	ZS-308846	T2BR30X08STL BZN PROJECTION
11	ZS-351886	PT BR30X10STL BNI
25	EZ-250356	INSULATOR BUSH AC311
26	ZW-383864J	WASHER INSULATE
27	ES-385553J	SW REMOTE O SPUR12
28	ES-385576J	SW REMOTE B SWWR10
32	EZ-200473	SILICON RUBBER SHEET TC-30
36	EZ-345459	TR SUPPORT BFG-20T0-3P
37	ZS-380046	PAN30X10STL CMT
38	ZS-419670	PAN30X12STL CMT
40	ZS-381181J	+6B40X060STL CMT
46A	*BT-385569J	TRANS POW A2050(U) [U]
46B	*BT-385570J	TRANS POW A2050(C,A) [C,A]
46C	*BT-385572J	TRANS POW A2050(EV) [E,V]
46D	*BT-385573J	TRANS POW A2050(B) [B]
47	ZS-365373	ST BID40X10STL CMT CUP
48	SZ-385531J	SHEET PREVENT SHAKING
49	ZW-385530J	BUSH TRANS
50	EJ-348218	PLUG SHORT PIN P2138
51	SK-379900J	KNOB MUTE
52	ZW-368205	FLEXIBLE RING 2414-0-0-086-01
53	BD-A2050A060A	PANEL FRONT BLK AM-95-B
67	ZS-308846	T2BR30X08STL BZN PROJECTION
68	ZS-463353	T2BR30X08STL BNI
69	ZS-565942	T2PAN40X08STL CMT
70	SC-379906J	COVER BOTTOM
71	SA-384387J	FOOT ROUND SHAPED(N)(2)
72	ZS-304021	ST BID40X12STL CMT
73	ZS-447840	T2BR30X08STL CMT
74	SK-379887J1	KNOB VR B PART
75	SK-379898J1	KNOB BALANCE PART
76	SK-379893J1	KNOB SELECTOR PART
77	SK-379896J1	KNOB SP PART
78	SK-373236B	KNOB POWER-B
79	ZW-381273J	SPACER
80A	SP-379905J	COVER UPPER(2) B [U,C,A]
80B	SP-381237J	COVER UPPER B [E,V,B]
83	SP-381364J	SIDE BOARD(L)
84	SP-381365J	SIDE BOARD(R)
85	ZW-376292	WASHER SIDE BOARD
86	ZS-376293	SCREW SIDE BOARD
87	ZS-308846	T2BR30X08STL BZN PROJECTION
88	ZS-381482J	SCREW TOP COVER(3) B OM
89	SZ-725384J	CAP OPTICAL PROTECTOR

NOTE:

Parts will not be supplied if they are not listed in the parts list, even if they appear on the assembling illustrations with reference No.

FANAL ASSEMBLY BLOCK

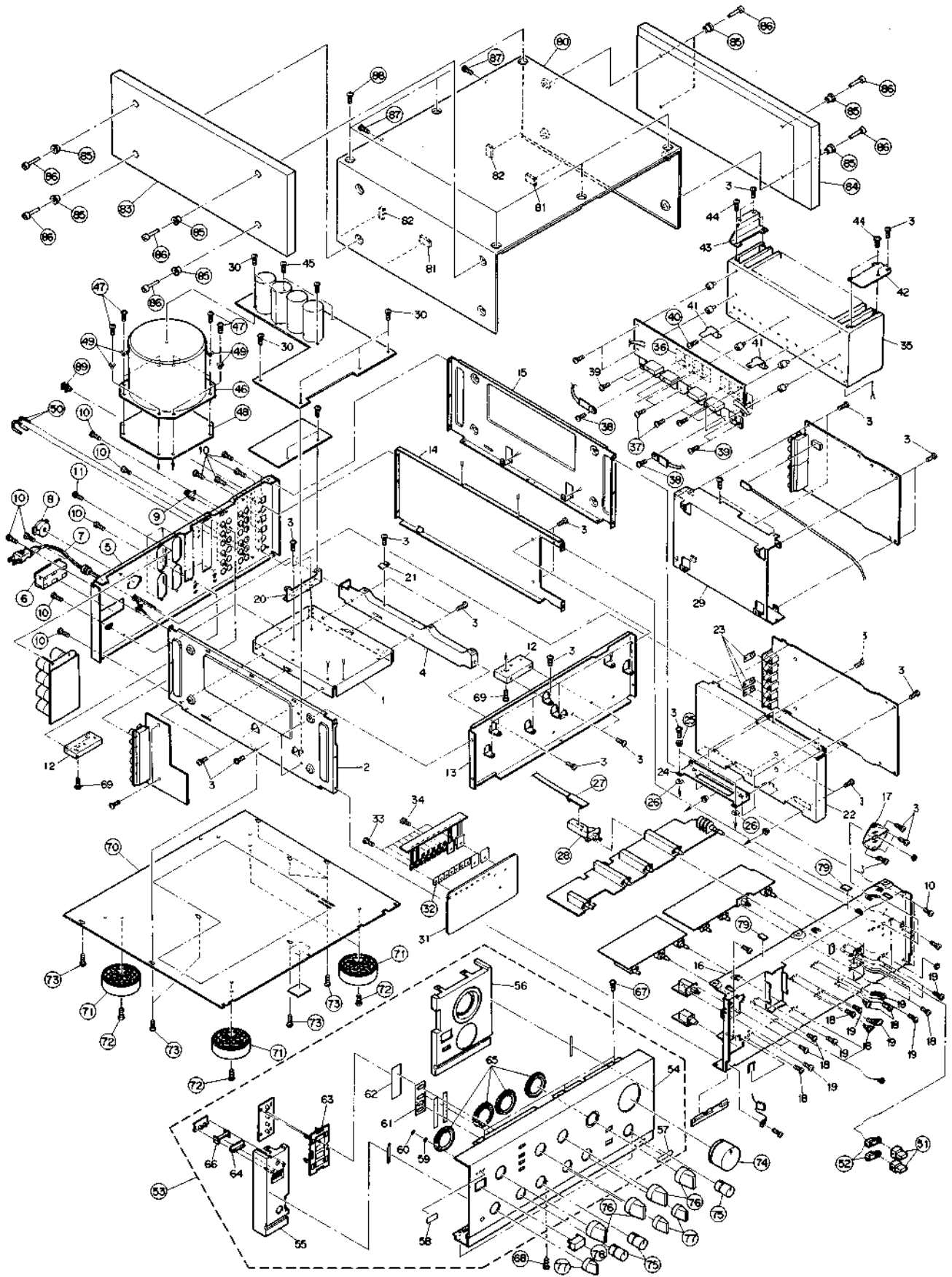

INDEX

Part No.	Ref. No.	Part No.	Ref. No.	Part No.	Ref. No.	Part No.	Ref. No.
BA-A2050A020A	2-1A	ED-348990	3-D6	EF-385542J	11-F1B	EQ-379982J	1-48
BA-A2050A020B	2-1B	ED-348990	3-D101	EF-623103	1-25	EQ-379982J	3-RL101
BA-A2050A020C	2-1C	ED-348990	3-D102	EF-623103	3-F3C	EQ-379982J	3-RL102
BA-A2050A020D	2-1D	ED-348990	3-D103	EF-623103	3-F4C	ER-324185	3-R43
BA-A2050A020E	2-1E	ED-348990	3-D104	EF-623103	3-F5C	ER-324185	3-R44
BA-A2050A050A	2-4	ED-351418	1-22	EH-383070J	1-33	ER-324185	3-R49
BA-A2050A070A	2-2A	ED-351418	3-D40	EH-383070J	10-FL101	ER-324185	3-R50
BA-A2050A070B	2-2B	ED-351418	3-D41	EH-383070J	10-FL102	ER-324186	10-R39
BA-A2050A070C	2-2C	ED-361885	1-8	EH-383070J	10-FL103	ER-333023	3-R101
BA-A2050A070D	2-2D	ED-361885	7-D601	EH-383070J	10-FL104	ER-333023	3-R102
BA-A2050A070E	2-2E	ED-361885	7-D602	EH-383070J	13-FL101	ER-338000	1-50
BA-A2057A040C	2-3A	ED-377933	1-18	EH-383070J	13-FL102	ER-338000	13-R301
BA-A2057A040D	2-3B	ED-377933	3-D16	EH-386991J	12-C401C	ER-338000	13-R302
BD-A2050A060A	18-53	ED-377933	3-D17	EI-344764	1-36	ER-355214	10-R44
BT-368261	1-5	ED-377933	3-D18	EI-344764	15-IC1	ER-368226	10-R46
BT-368261	17-T1	ED-377933	3-D19	EI-345474	1-34	ER-368226	10-R47
BT-385569J	1-4	ED-379981J	1-10	EI-345474	3-IC1	ER-372991	10-R37
BT-385569J	18-46A	ED-379981J	3-D10	EI-356049	1-43	ER-372991	10-R38
BT-385570J	1-2	ED-379981J	3-D11	EI-356049	17-IC11	ER-378499J	3-R22
BT-385570J	18-46B	ED-379981J	3-D12	EI-360037	1-42	ER-378846J	3-R45
BT-385572J	1-3	ED-379981J	3-D13	EI-360037	17-IC5	ER-378846J	10-R35
BT-385572J	18-46C	ED-379981J	3-D20	EI-360040	1-41	ER-381264J	3-R18
BT-385573J	1-1	ED-379981J	3-D21	EI-360040	17-IC3	ER-381265J	3-R51A
BT-385573J	18-46D	ED-379981J	3-D28	EI-360040	17-IC6	ER-381265J	3-R52A
EC-201636	3-C17	ED-379981J	3-D29	EI-362587	1-37	ER-381265J	3-R103
EC-201636	3-C18	ED-379981J	3-D34	EI-362587	10-IC1	ER-382604J	13-R127
EC-320548	12-C401A	ED-379981J	3-D35	EI-362588	1-38	ER-382604J	13-R128
EC-324074	3-C11	ED-379981J	3-D36	EI-362588	13-IC201	ER-382613J	3-R33
EC-324074	3-C12	ED-379981J	3-D37	EI-368612	1-40	ER-382613J	3-R34
EC-338496	12-C401B	ED-379981J	3-D44	EI-368612	17-IC12	ER-382613J	3-R39
EC-347375	10-C10	ED-379981J	3-D45	EI-375346	1-35	ER-382613J	3-R40
EC-347375	10-C11	ED-381270J	1-19	EI-375346	17-IC7	ER-382614J	3-R54
EC-347408	13-C150	ED-381270J	3-D24	EI-377191	1-39	ER-382614J	3-R55
EC-355434	3-C13	ED-381270J	3-D25	EI-377191	17-IC13	ER-382614J	3-R56
EC-355434	3-C14	ED-381270J	3-D26	EI-378921J	1-44	ER-382614J	3-R57
EC-368036	17-C36	ED-381270J	3-D27	EI-378921J	17-IC4	ER-382614J	3-R58
EC-368039	3-C30	ED-382611J	1-7	EI-379997J	1-46	ER-382614J	3-R59
EC-377960	10-C1	ED-382611J	3-D38	EI-379997J	17-IC9	ER-383007J	10-R40
EC-377960	15-C101	ED-382611J	3-D39	EI-382925J	1-47	ER-383007J	10-R41
EC-378457	17-C33	ED-382620J	1-6	EI-382925J	17-X1	ER-383007J	10-R42
EC-378457	17-C34	ED-382620J	6-D501	EI-386485J	1-45	ER-383007J	10-R43
EC-378515J	3-C28	ED-382620J	6-D502	EI-386485J	17-IC10	ER-387931J	3-R51B
EC-380325J	17-C29	ED-382620J	6-D503	EJ-329610	18-9	ER-387931J	3-R52B
EC-381267J	10-C3	ED-382620J	6-D504	EJ-336904	5-J1	ES-349070	18-8
EC-381267J	10-C4	ED-382668J	1-14	EJ-336904	5-J2	ES-355407	1-51
EC-381267J	13-C202	ED-382668J	3-D1	EJ-336904	13-J101	ES-355407	12-SW1
EC-381267J	13-C203	ED-383034J	1-9	EJ-336904	13-J102	ES-378941J	1-52
EC-382572J	10-C5	ED-383034J	3-D14	EJ-337405	18-6A	ES-378941J	16-SW3
EC-382572J	13-C201	ED-383034J	3-D15	EJ-348218	18-50	ES-379984J	1-54
EC-387907J	3-C1	ED-383034J	3-D22	EJ-352642	18-6B	ES-379984J	14-SW304
EC-387907J	3-C2	ED-383034J	3-D23	EJ-369995	8-J701	ES-379984J	15-SW1
ED-301911	1-12	ED-383034J	3-D30	EJ-377170	17-J3	ES-379986J	1-55
ED-301911	3-D7	ED-383034J	3-D31	EJ-377170	17-J4	ES-379986J	14-SW301
ED-301911	3-D8	ED-385575J	1-13	EJ-377170	17-J5	ES-379986J	16-SW1
ED-301911	3-D9	ED-385575J	3-D4	EJ-383549J	17-J8	ES-379988J	1-56
ED-301911	3-D46	ED-385575J	3-D5	EJ-385272J	17-J6	ES-379988J	14-SW303
ED-301911	3-D47	ED-385575J	10-D1	EJ-385272J	17-J7	ES-379988J	16-SW2
ED-301911	13-D101	ED-385575J	10-D2	EJ-385565J	4-TM901	ES-385552J	1-53
ED-301911	13-D102	EF-242605	1-26	EO-318379	17-L2	ES-385552J	13-SW101
ED-301911	16-D1	EF-242605	11-F1C	EO-332116	3-L101	ES-385553J	18-27
ED-301911	17-D1	EF-309388	1-29	EO-332116	11-L301	ES-385576J	18-28
ED-301911	17-D2	EF-309388	3-F5A	EO-345909	17-L3	ET-308141	1-73
ED-301911	17-D3	EF-309390	1-31	EO-345909	17-L4	ET-308141	10-TR11
ED-301911	17-D4	EF-309390	3-F3B	EO-345909	17-L5	ET-308141	13-TR202
ED-301911	17-D5	EF-309390	3-F4B	EO-345909	17-L6	ET-308472	1-63
ED-343410	1-20	EF-309391	1-32	EO-345909	17-L7	ET-308472	13-TR201
ED-343410	14-D1	EF-309391	3-F5B	EO-345909	17-L8	ET-338244	1-64
ED-346529	1-21	EF-327103	1-27	EO-345909	17-L9	ET-338244	3-TR3
ED-346529	3-D42	EF-327103	3-F3A	EO-345909	17-L10	ET-338244	3-TR6
ED-346560	1-15	EF-327103	3-F4A	EO-345909	17-L11	ET-338244	3-TR8
ED-346560	3-D43	EF-341260	1-28	EO-345909	17-L12	ET-338244	3-TR12
ED-346564	1-16	EF-341260	11-F1A	EO-345909	17-L13	ET-338244	10-TR4
ED-346564	3-D32	EF-341260	11-F2	EO-345913	17-L1	ET-338244	10-TR5
ED-346564	3-D33	EF-355226	1-23	EO-345922	17-L14	ET-338244	10-TR7
ED-346570	1-17	EF-355226	3-F3D	EO-345922	17-L15	ET-338244	10-TR8
ED-346570	13-D301	EF-355226	3-F4D	EO-353587	13-L101	ET-345460	1-65
ED-346570	13-D302	EF-355226	3-F5D	EO-353587	13-L102	ET-345460	10-TR14
ED-348990	1-11	EF-355399	1-24	EO-378920J	17-FL1	ET-345625	1-76
ED-348990	3-D2	EF-355399	11-F1D	EQ-348929	1-49	ET-345625	9-TR803
ED-348990	3-D3	EF-385542J	1-30	EQ-348929	3-RL103	ET-345625	9-TR805

PARTS LIST

INDEX

Part No.	Ref. No.	Part No.	Ref. No.	Part No.	Ref. No.	Part No.	Ref. No.
ET-345625	9-TR807	EV-379993J	1-87				
ET-345625	9-TR809	EV-379993J	15-VR2				
ET-345626	1-67	EV-379994J	1-85				
ET-345626	9-TR804	EV-379994J	16-VR1				
ET-345626	9-TR806	EV-387949J	1-89				
ET-345626	9-TR808	EV-387949J	14-VR1Z				
ET-348829	1-66	EW-363646	18-7B				
ET-348829	10-TR12	EW-363658	18-7A				
ET-348830	1-74	EW-363671	18-7C				
ET-348830	3-TR7	EW-363683	18-7D				
ET-348830	3-TR9	EZ-200473	18-32				
ET-348830	3-TR13	EZ-250356	18-25				
ET-348830	10-TR3	EZ-345459	18-36				
ET-348830	10-TR6	SA-384387J	18-71				
ET-348830	10-TR9	SC-379906J	18-70				
ET-348830	10-TR10	SK-373236B	18-78				
ET-349081	1-79	SK-379887J1	18-74				
ET-349081	3-TR1	SK-379893J1	18-76				
ET-349081	3-TR11	SK-379896J1	18-77				
ET-349081	13-TR104	SK-379898J1	18-75				
ET-349081	13-TR105	SK-379900J	18-51				
ET-349081	13-TR106	SP-379905J	18-80A				
ET-349081	17-TR5	SP-379915J	18-5A				
ET-349081	17-TR6	SP-379916J	18-5B				
ET-349459	1-83	SP-379917J1	18-5C				
ET-349459	3-TR15	SP-379918J1	18-5D				
ET-352726	1-69	SP-381237J	18-80B				
ET-352726	3-TR10	SP-381364J	18-83				
ET-352726	13-TR103	SP-381365J	18-84				
ET-352726	17-TR2	SZ-385531J	18-48				
ET-352726	17-TR4	SZ-725384J	18-89				
ET-354371	1-58	ZS-304021	18-72				
ET-354371	17-TR1	ZS-308846	18-10				
ET-354371	17-TR3	ZS-308846	18-67				
ET-354601	1-72	ZS-308846	18-87				
ET-354601	13-TR302	ZS-351886	18-11				
ET-354897	1-61	ZS-365373	18-47				
ET-354897	10-TR1	ZS-376293	18-86				
ET-354897	13-TR101	ZS-380046	18-37				
ET-357162	1-60	ZS-381181J	18-40				
ET-357162	10-TR2	ZS-381482J	18-88				
ET-357162	13-TR102	ZS-419670	18-38				
ET-359827	1-62	ZS-447840	18-73				
ET-359827	3-TR14	ZS-463353	18-68				
ET-360067	1-78	ZS-565942	18-69				
ET-360067	3-TR4	ZW-368205	18-52				
ET-360067	3-TR5	ZW-376292	18-85				
ET-360646	1-57	ZW-381273J	18-79				
ET-360646	14-TR1	ZW-383864J	18-26				
ET-360646	14-TR2	ZW-385530J	18-49				
ET-360646	14-TR3						
ET-364060	1-59						
ET-364060	17-TR7						
ET-368757	1-70						
ET-368757	9-TR802						
ET-368759	1-80						
ET-368759	9-TR801						
ET-370038	1-75						
ET-370038	10-TR13						
ET-371028	1-82						
ET-371028	13-TR301						
ET-385557J	1-77						
ET-385557J	10-TR15						
ET-385559J	1-81						
ET-385559J	10-TR17						
ET-385559J	10-TR18						
ET-385561J	1-71						
ET-385561J	10-TR19						
ET-385561J	10-TR20						
ET-385577J	1-68						
ET-385577J	10-TR16						
EV-330369	10-VR1						
EV-337996	17-VR1						
EV-347942	13-VR201						
EV-379987J	1-84						
EV-379987J	14-SW302						
EV-379989J	1-88						
EV-379989J	14-VR1						
EV-379992J	1-86						
EV-379992J	15-VR1						

ABBREVIATIONS (AMPLIFIER)

ABBREVIATIONS	EXPLANATION
A	Analog
AC	Alternating Current
AMP	AMPlifier
CD	Compact Disc
COM	COMMon
D	Digital
D/A	Digital to Analog
DAC	Digital to Analog Converter
DAT	Digital Audio Tape recorder
DC	Direct Current
GND	GrouND
L	Left
LED	Light Emitting Diode
MC	Moving Coil
MM	Moving Magnet
PCB	Printed Circuit Board
R	Right
REG.	REGulator
REC	RECord
TR	TRansistor
SW	SWitch
V.AMP	Voltage AMPlifier
V.DISC	Video DISC
VR	Variable Resistance
VTR	Video Tape Recorder

AKAI ELECTRIC CO., LTD.

12-14, 2-Chome, Higashi-Kojiya, Ohta-Ku, Tokyo, Japan
SERVICE DEPARTMENT TEL: Tokyo(745)9884 TOKYO TELEX: J26261
Printed No. 880921-A1-2200 Printed Date: October 27, 1988
350 Printed in Japan

AKAI

MODEL AM-93

SCHEMATIC DIAGRAM AND PC BOARDS

TABLE OF CONTENTS

1. IC's	2
2. FUSE AND OTHER PC BOARDS	3
3. MAIN, CONNECTOR AND REGULATOR PC BOARDS	4
4. CONNECTION DIAGRAM	5
5. POWER AMP SCHEMATIC DIAGRAM	6
6. POWER AMP PC BOARD	7
7. EQUALIZER SCHEMATIC DIAGRAM	8
8. EQUALIZER PC BOARD	9
9. DAC SCHEMATIC DIAGRAM	10
10. DAC PC BOARD	11
11. REC SELECTOR, TONE CONTROL, AND INPUT SCHEMATIC DIAGRAM	12
12. REC SELECTOR, TONE CONTROL, TAPE, AND INPUT PC BOARDS	13
13. BLOCK DIAGRAM	14

74HC139 (Dual 2 to 4 Demultiplexers)

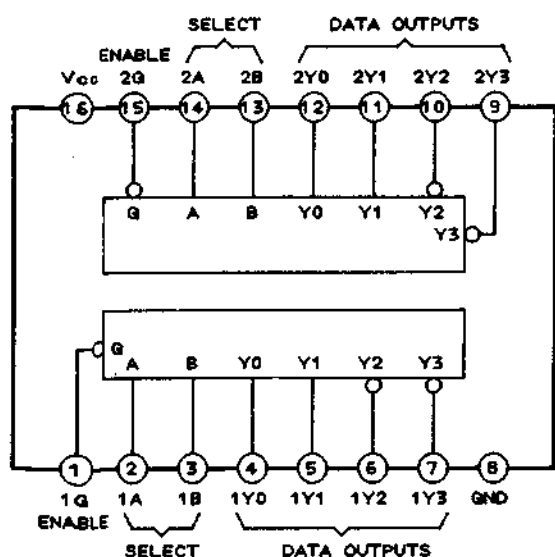

Function Table

INPUTS		OUTPUTS			
ENABLE	SELECT	Y0	Y1	Y2	Y3
H	X X	H	H	H	H
L	L L	L	H	H	H
L	L H	H	L	H	H
L	H L	H	H	L	H
L	H H	H	H	H	L

74HC151P (8 to 1 Data Selector)

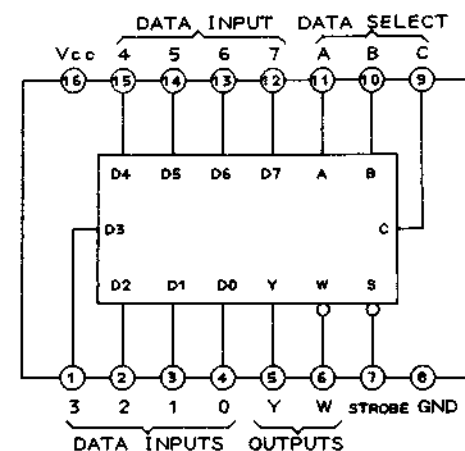

Function Table

INPUTS			OUTPUTS	
SELECT	STROBE		Y	W
C B A	S			
X X X	H		L	H
L L L	L		D0	$\overline{D0}$
L L H	L		D1	$\overline{D1}$
L H L	L		D2	$\overline{D2}$
L H H	L		D3	$\overline{D3}$
H L L	L		D4	$\overline{D4}$
H L H	L		D5	$\overline{D5}$
H H L	L		D6	$\overline{D6}$
H H H	L		D7	$\overline{D7}$

PCM56P (D/A Converter)

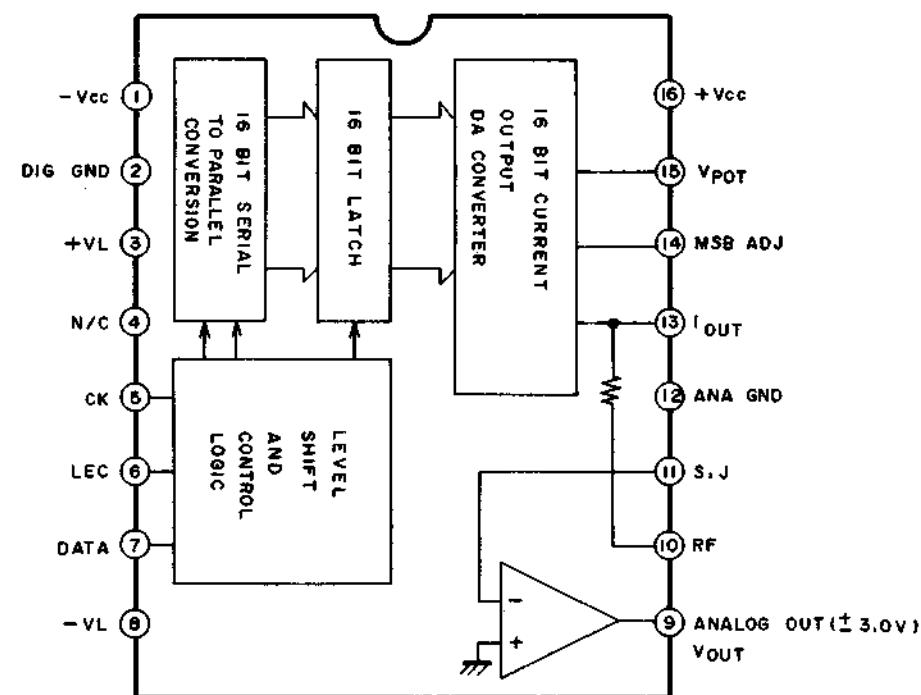

PIN NO.	SYMBOL	DESCRIPTION
1	-Vcc	Analog + power supply
2	DIG GND	Digital ground
3	+V1	Logic + power supply
4	N.C	
5	CK	Clock input
6	LEC	Latch enable control
7	DATA	Data input
8	-V1	Logic - power supply
9	Vout	Voltage output
10	RF	Terminal for feedback resistor
11	SJ	Summing junction (OP Amp input)
12	ANA GND	Analog ground
13	Iout	Current output
14	MSB ADJ	Terminal for MSB adjustment
15	Vpot	Terminal for potentiometer
16	+Vcc	Analog + power supply

(PU): Terminal pulled up inside of IC

ICIHA12002 (Power Amp Protector)

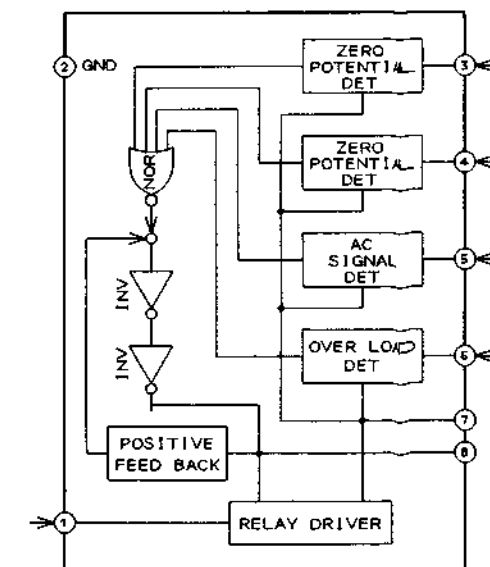

YM3623 (Digital Audio Interface Receiver)

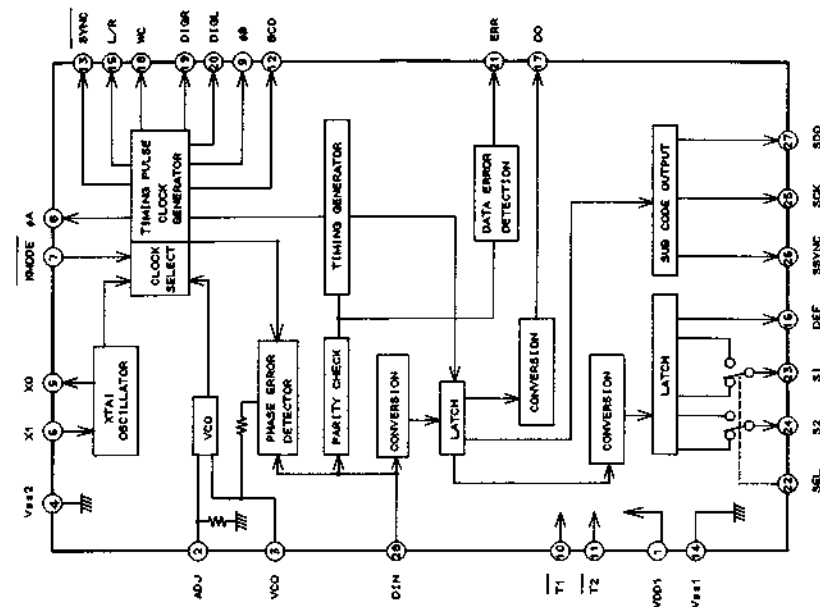

PIN NO.	SYMBOL	I/O	DESCRIPTION OF TERMINAL														
1	VDD1		+B (+5V) for System Section														
2	ADJ	I	No Connection														
3	VCO	I/O	External Capacitor Connection Terminal for VCO														
4	VSS2		GND for VCO Circuit														
5	XO	O	} X'tal Oscillator														
6	XI	I															
7	$\overline{\text{K MODE}}$	I(P)	H: When Data Input into DIN Terminal. Clock Signal Abstracted from Input Data by PLL Circuit. If No Data Input Data into DIN Clock Signal Use from X'tal OSC. L: Always Use X'tal Oscillation														
8	ϕA	O	<ul style="list-style-type: none"> When Using X'tal OSC = 16.934 MHz When Operating PLL Circuit = Changing the Frequency According to Input Data of DIN. (About 16.934 MHz at $f_s = 44.1$ kHz) 														
9	ϕB	O	<ul style="list-style-type: none"> When Using X'tal OSC = $\phi A/3$ When Operating PLL Circuit = Changing the Frequency According to Input Data. (About 5.6448 MHz at $f_s = 44.1$ kHz) 														
10	$\overline{T1}$	I(P)	} For Check of Internal Circuit														
11	$\overline{T2}$	I(P)															
12	BCO	O	Timing Clock for the Output Signal from DO														
13	SYNC	O	SYNCHRONOUS Signal Output														
14	VSS1	O	GND of System Section														
15	$\overline{\text{L/R}}$	O	Data Output Select from DO (H = L ch., L = R ch.)														
16	DEF	O	H = DE-EMPHASIS "ON", L = DE-EMPHASIS "OFF"														
17	DO	O	16 Bit Data Output														
18	WC	O	When Data is Output to DO = H														
19	DIGR	O	Signal Output for R ch. Deglitch														
20	DIGL	O	Signal Output for L ch. Deglitch														
21	ERR	O	H = Parity Error, L = NO ERROR														
22	SEL	I(P)	Function Select Signal of S1 and S2														
23	S1	O	<table border="1"> <tr> <td>SEL = L</td> <td></td> <td>NO</td> <td>YES</td> </tr> <tr> <td>(COPY)</td> <td>S1</td> <td>L</td> <td>H</td> </tr> <tr> <td></td> <td>S2</td> <td>L</td> <td>H</td> </tr> </table>	SEL = L		NO	YES	(COPY)	S1	L	H		S2	L	H		
SEL = L			NO	YES													
(COPY)	S1	L	H														
	S2	L	H														
24	S2	<table border="1"> <tr> <td>SEL = H</td> <td></td> <td>44.1 kHz</td> <td>48 kHz</td> <td>32 kHz</td> </tr> <tr> <td>(Sampling frequency)</td> <td>S1</td> <td>L</td> <td>L</td> <td>H</td> </tr> <tr> <td></td> <td>S2</td> <td>L</td> <td>H</td> <td>H</td> </tr> </table>	SEL = H		44.1 kHz	48 kHz	32 kHz	(Sampling frequency)	S1	L	L	H		S2	L	H	H
SEL = H		44.1 kHz	48 kHz	32 kHz													
(Sampling frequency)	S1	L	L	H													
	S2	L	H	H													
25	SCK	O	Clock Signal for Sub Code														
26	SSYNC	O	SYNC Signal for Sub Code														
27	SDO	O	Sub Code Data Output														
28	DIN	I	Data Input														

YM3414 (8fs Over Sampling Digital Filter)

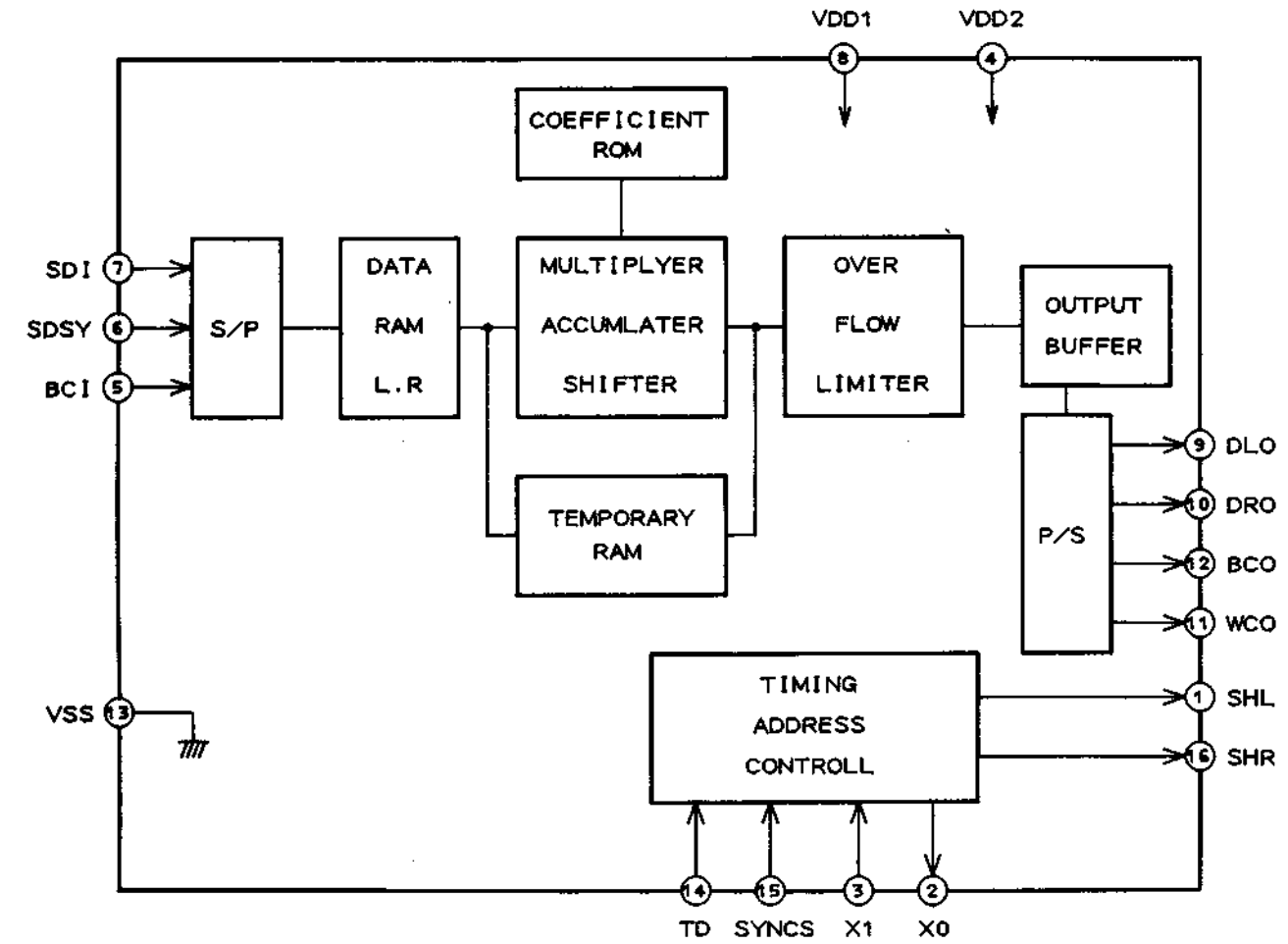

YM3414

Pin No.	Name	I/O	Contents
1	SHL	O	1 DAC (TD = "L"): Lch Deglitcher signal (at 4 times over sampling) 2 DAC (TD = "H"): L/Rch Deglitcher signal (at 8 times over sampling)
2	XO	O	Connect X'tal element between XI and XO
3	XI	I	XI clock = 384xfs (connection of EXT clock to XI clock is possible)
4	VDD2	-	+B (+5V) for X'tal OSC and Deglitcher signal circuit
5	BCI	I	Bit clock input for input data
6	SDSY	I	L/Rch division and input timing clock for input data
7	SDI	I	16 bit Serial Data input
8	VDD1	-	+B (+5V) for Digital signal circuit
9	DLO	O	1 DAC (TD = "L"): L.Rch Data output (at 4 times over sampling) 2 DAC (TD = "H"): Lch Data output (at 8 times over sampling)
10	DRO	O	Rch Data output
11	WCO	O	Word clock for DLO and RLO
12	BCO	O	Bit clock output for DLO and RLO
13	VSS	-	GND
14	TD	I	1 DAC/2 DAC Select input: 1 DAC (4 times over sampling) = "L" : 2 DAC (8 times over sampling) = "H"
15	SyncS	I	Sync signal for absorbing Jitter from asynchronous data (SyncS = "H": at synchronous data input to SDI) (SyncS = "L": at asynchronous data input to SDI)
16	SHR	O	Rch Deglitcher signal at 1 DAC

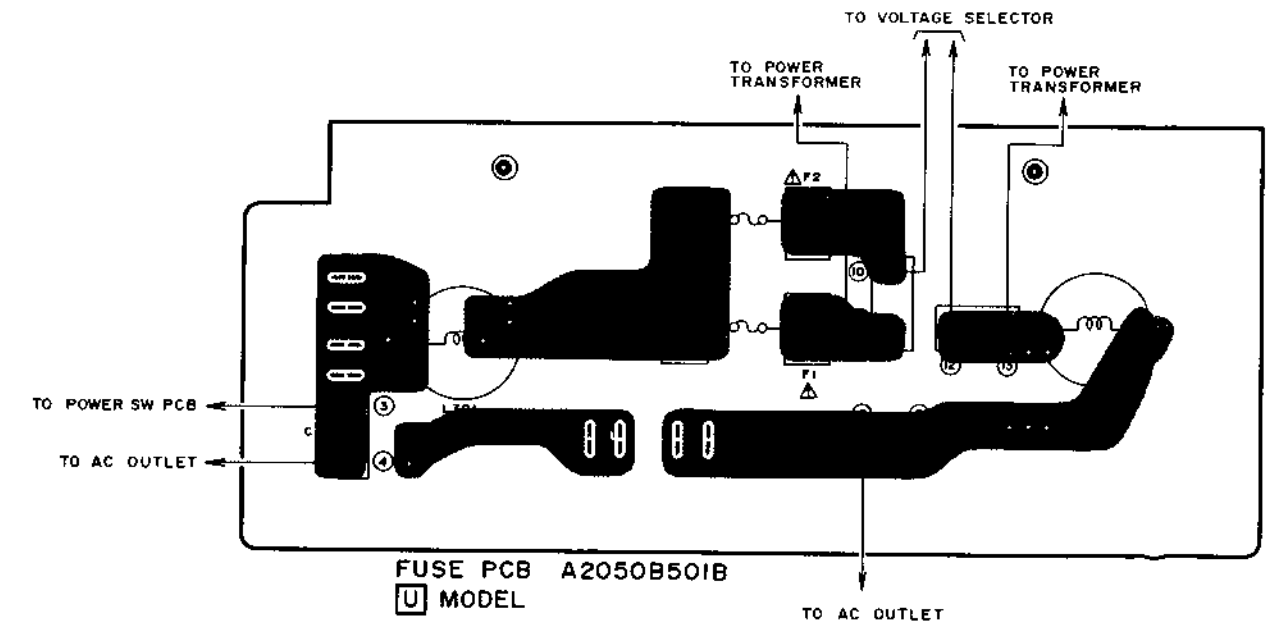
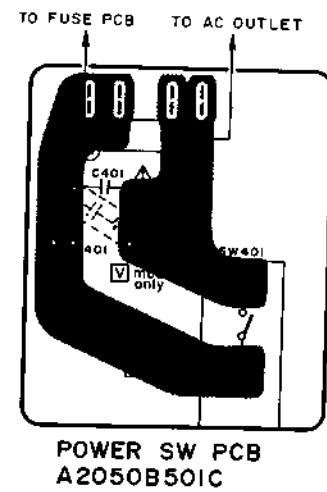
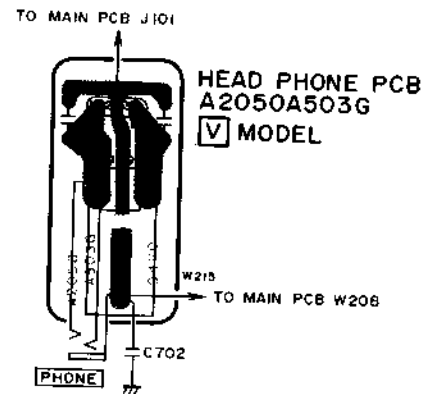
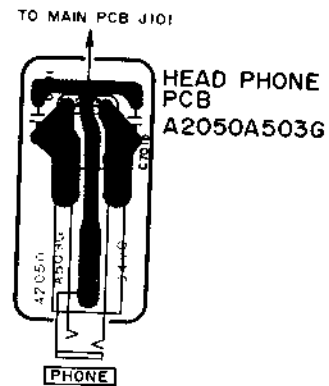
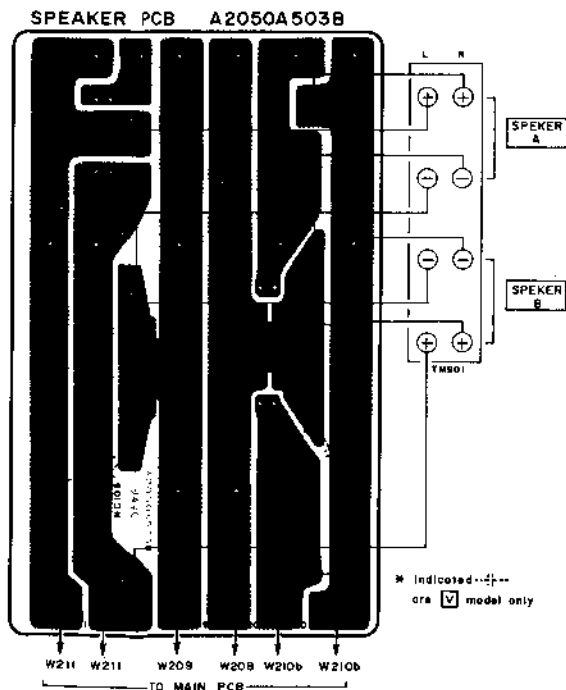
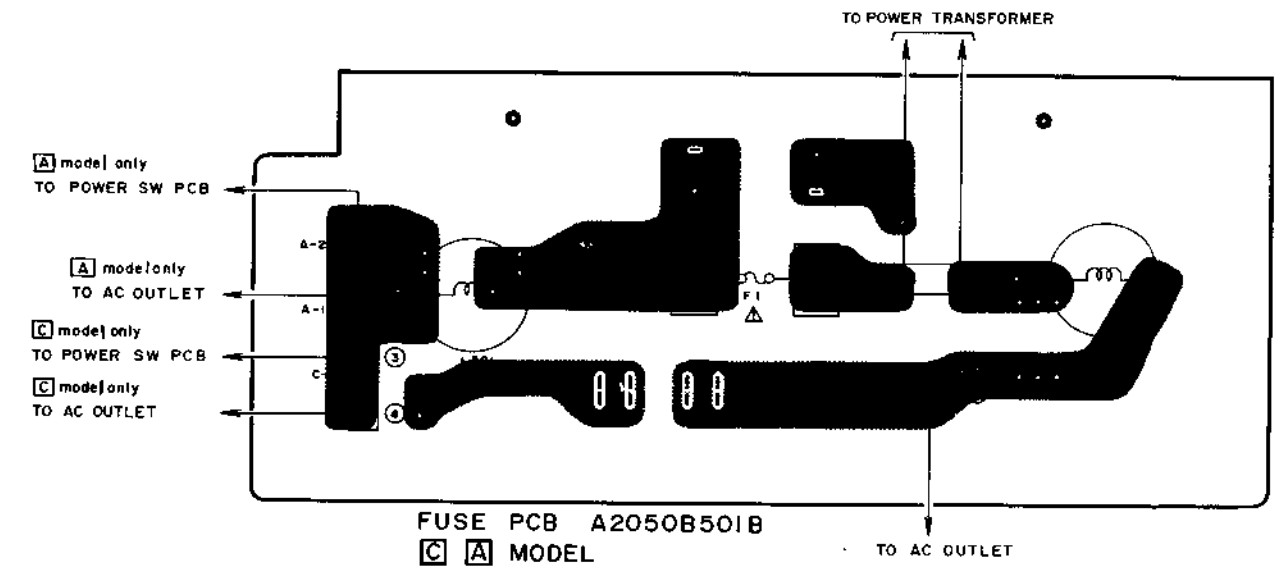
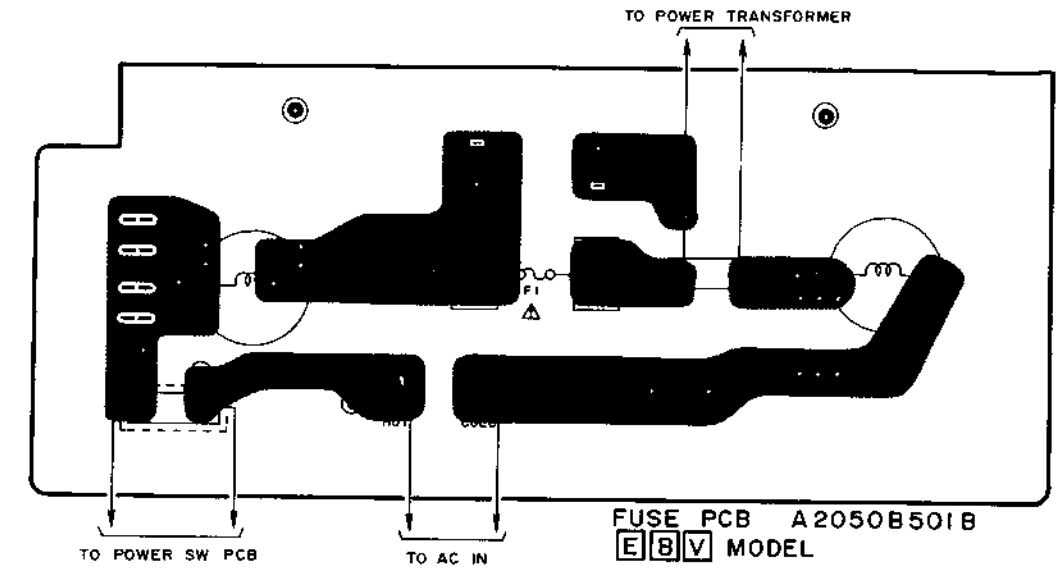
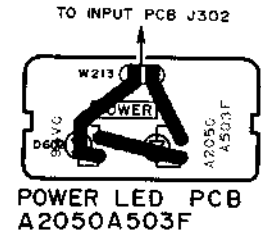
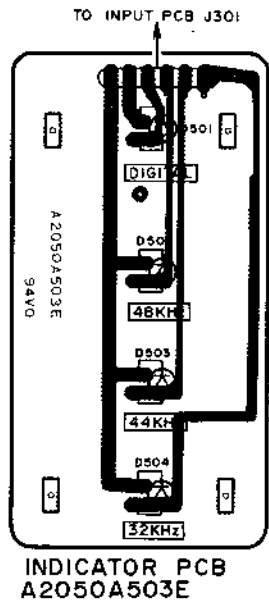

WARNING: Δ INDICATES SAFETY CRITICAL COMPONENTS. FOR CONTINUED SAFETY, REPLACE SAFETY CRITICAL COMPONENTS ONLY WITH MANUFACTURER'S RECOMMENDED PARTS.

AVERTISSEMENT: Δ IL INDIQUE LES COMPOSANTS CRITIQUES DE SÉCURITÉ. POUR MAINTENIR LE DEGRÉ DE SÉCURITÉ DE L'APPAREIL, NE REMPLACER QUE DES PIÈCES RECOMMANDÉES PAR LE FABRICANT.

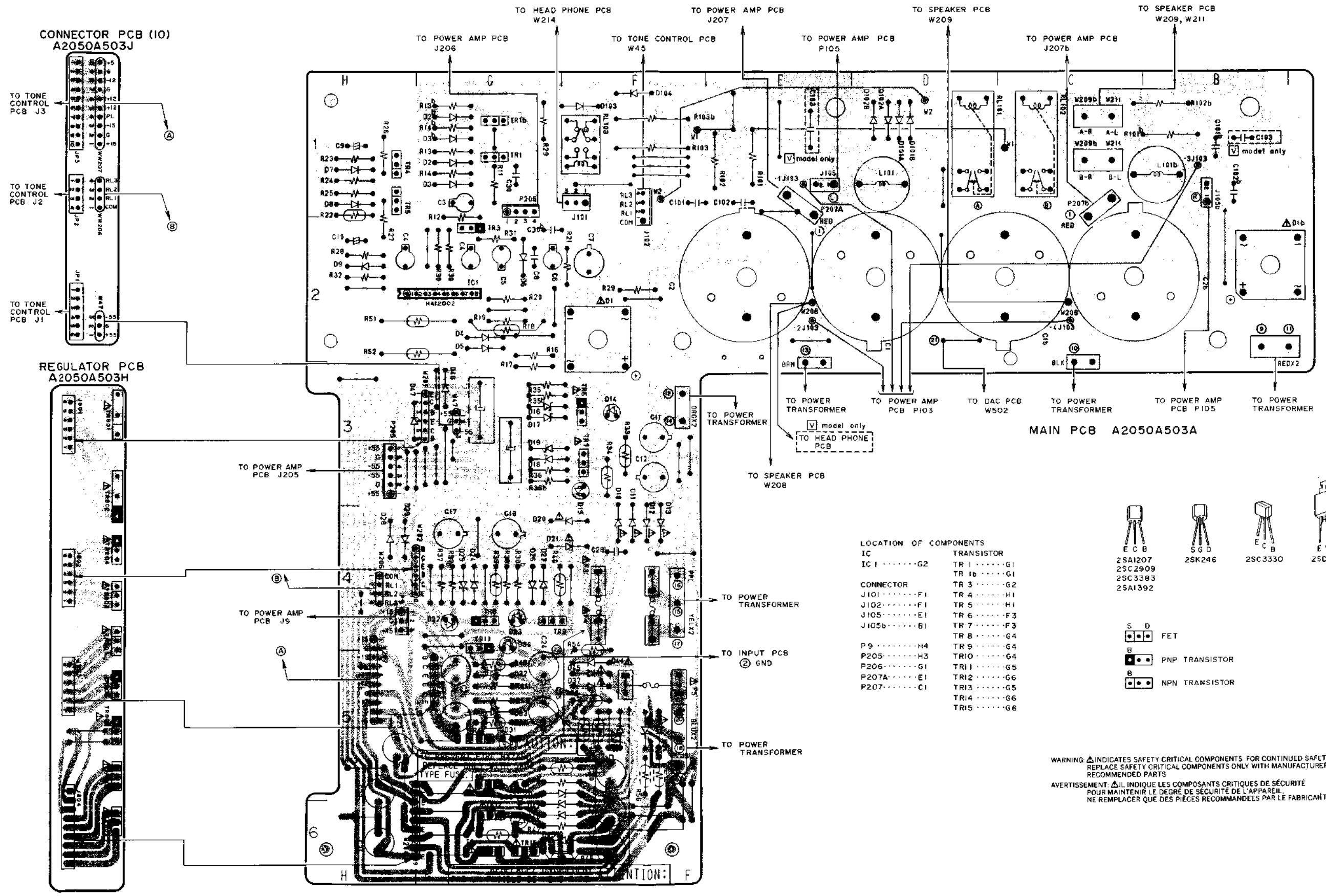

LOCATION OF COMPONENTS

IC	TRANSISTOR
IC 1	TR 1
	TR 1b
	TR 3
	TR 4
	TR 5
	TR 6
	TR 7
	TR 8
	TR 9
	TR 10
	TR 11
	TR 12
	TR 13
	TR 14
	TR 15

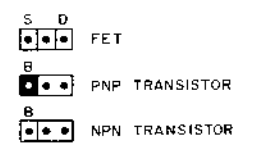
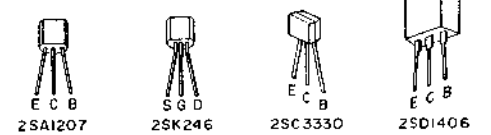

WARNING: Δ INDICATES SAFETY CRITICAL COMPONENTS FOR CONTINUED SAFETY. REPLACE SAFETY CRITICAL COMPONENTS ONLY WITH MANUFACTURER'S RECOMMENDED PARTS.

AVERTISSEMENT: Δ IL INDIQUE LES COMPOSANTS CRITIQUES DE SÉCURITÉ POUR MAINTENIR LE DEGRÉ DE SÉCURITÉ DE L'APPAREIL. NE REMPLACER QUE DES PIÈCES RECOMMANDÉES PAR LE FABRICANT.

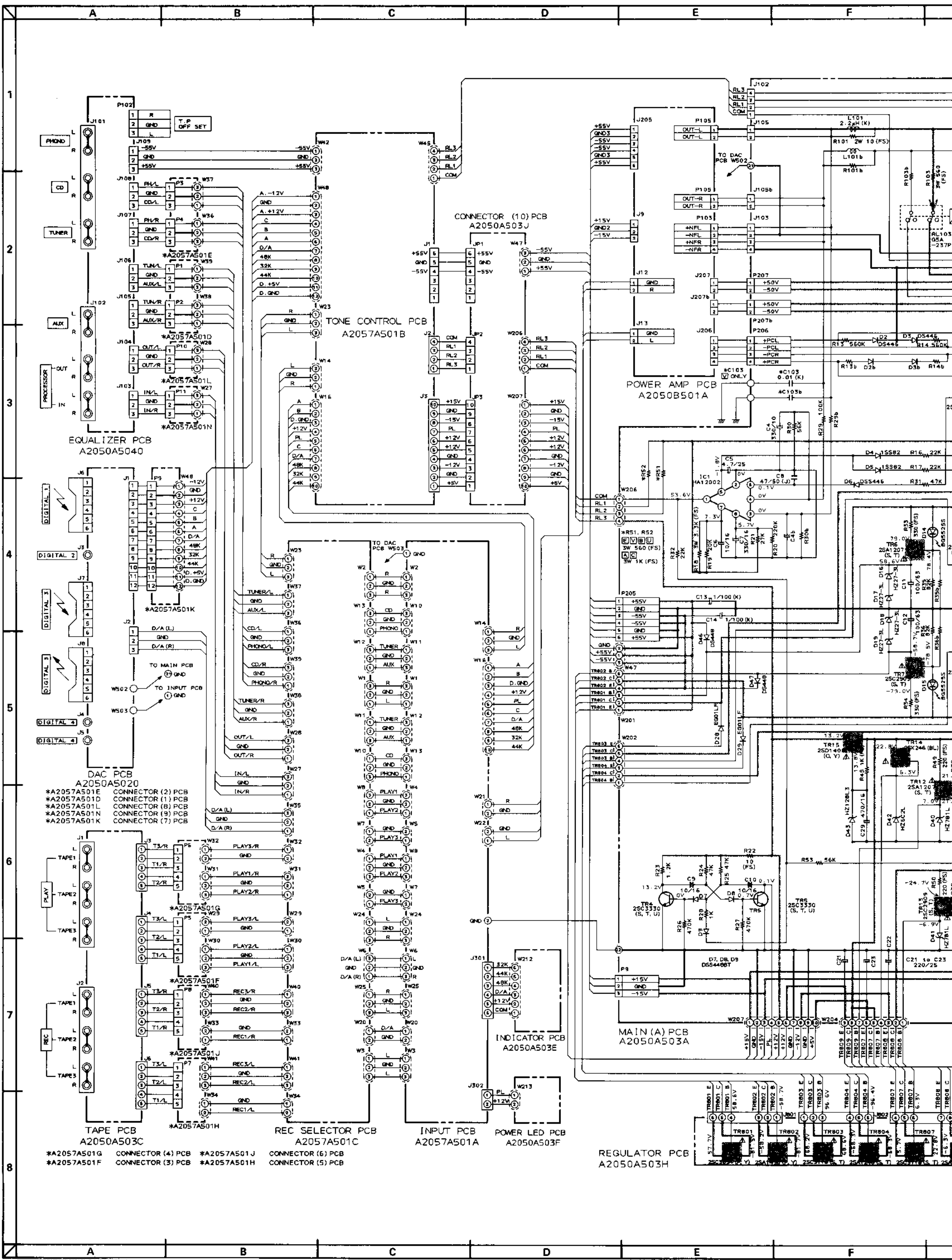

*A2057A501G CONNECTOR (4) PCB *A2057A501J CONNECTOR (6) PCB
 *A2057A501F CONNECTOR (3) PCB *A2057A501H CONNECTOR (5) PCB

REGULATOR PCB
 A2050A503H

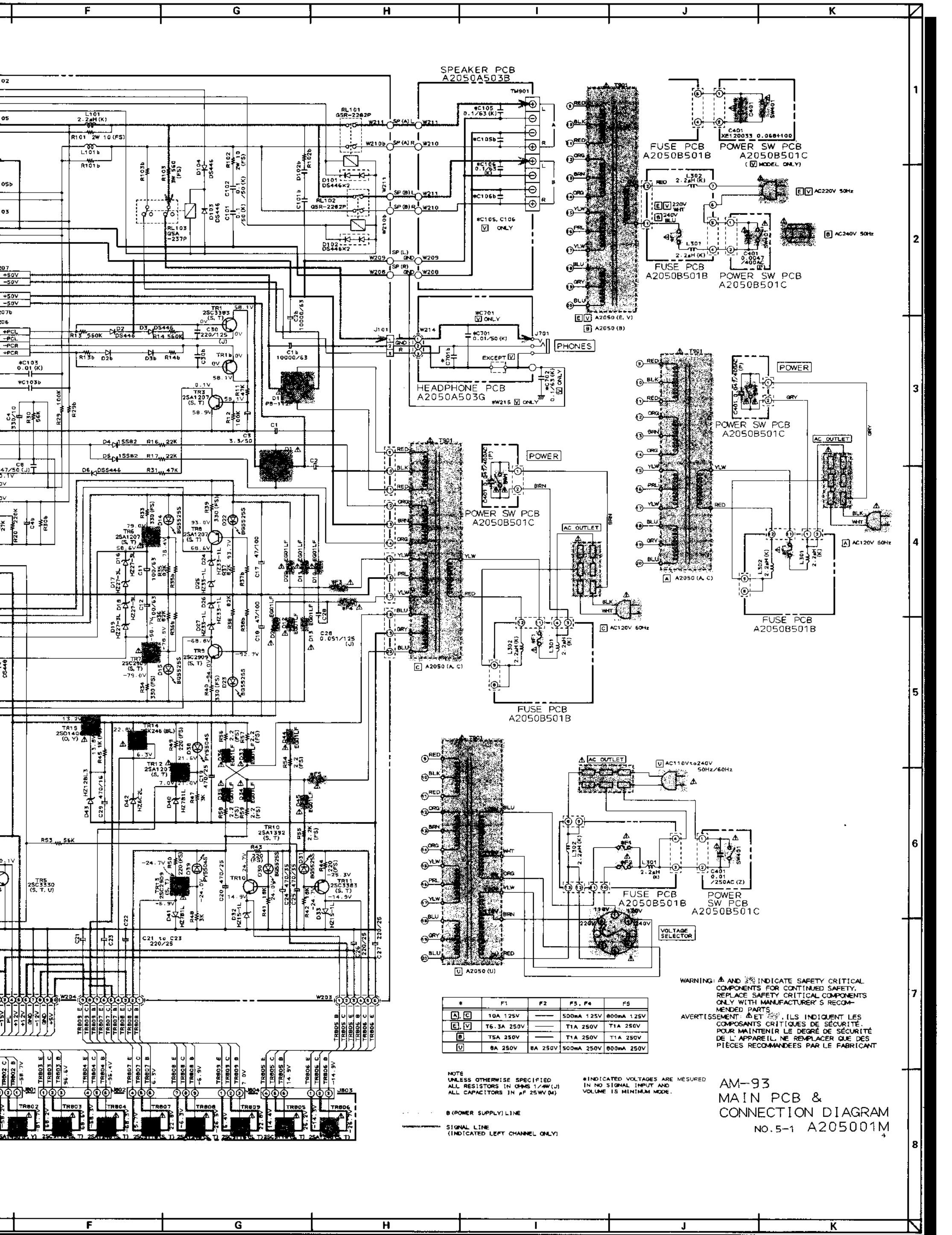

SPEAKER PCB
A2050A503B

HEADPHONE PCB
A2050A503G

FUSE PCB
A2050B501B

POWER SW PCB
A2050B501C

FUSE PCB
A2050B501B

POWER SW PCB
A2050B501C

POWER SW PCB
A2050B501C

FUSE PCB
A2050B501B

FUSE PCB
A2050B501B

POWER SW PCB
A2050B501C

*	F1	F2	F3, F4	F5
A, C	10A 125V	—	500mA 125V 800mA 125V	—
E, V	T6.3A 250V	—	T1A 250V T1A 250V	—
B	T5A 250V	—	T1A 250V T1A 250V	—
U	8A 250V	8A 250V	500mA 250V 800mA 250V	—

NOTE: UNLESS OTHERWISE SPECIFIED, ALL RESISTORS IN OHMS (Ω) OR IN OHMS PER WATT (Ω/W). ALL CAPACITORS IN μF (μF) OR IN PICO FARADS (pF).
* INDICATED VOLTAGES ARE MEASURED IN NO SIGNAL INPUT AND VOLUME IS MINIMUM MODE.

B (POWER SUPPLY) LINE
SIGNAL LINE (INDICATED LEFT CHANNEL ONLY)



WARNING: ⚠ AND ⚡ INDICATE SAFETY CRITICAL COMPONENTS FOR CONTINUED SAFETY. REPLACE SAFETY CRITICAL COMPONENTS ONLY WITH MANUFACTURER'S RECOMMENDED PARTS.
AVERTISSEMENT: ⚠ ET ⚡ ILS INDIQUENT LES COMPOSANTS CRITIQUES DE SÉCURITÉ. POUR MAINTENIR LE DEGRÉ DE SÉCURITÉ DE L'APPAREIL, NE REMPLACER QUE DES PIÈCES RECOMMANDÉES PAR LE FABRICANT.



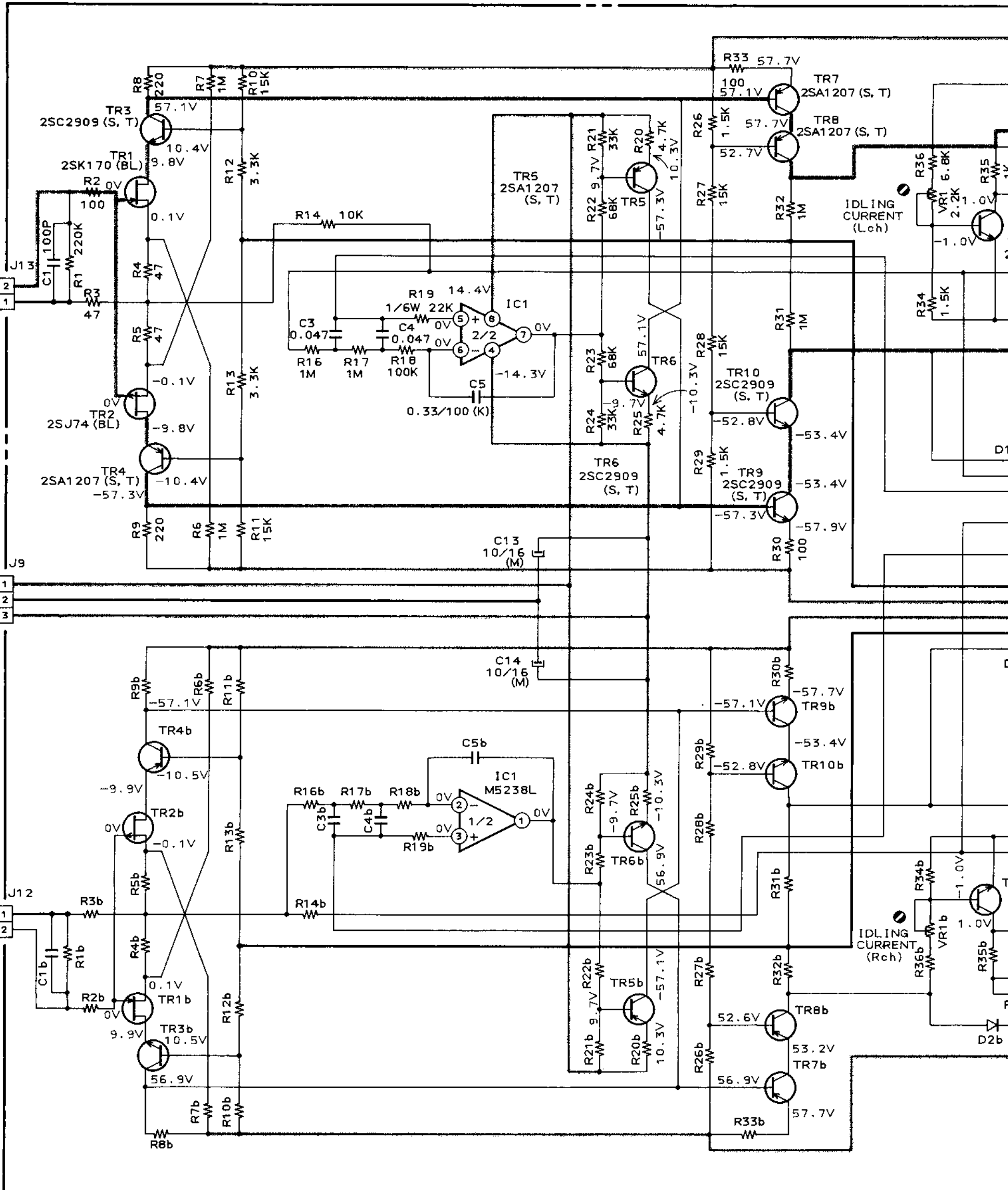

AM-93
MAIN PCB &
CONNECTION DIAGRAM
No. 5-1 A205001M

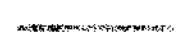
1
2
3
4
5
6
7
8



POWER AMP PCB A2050B501A

 B (POWER SUPPLY) LINE
 SIGNAL LINE
 (INDICATED LEFT CHANNEL ONLY)

WARNING:  AND  INDICATE SAFETY CRITICAL COMPONENTS FOR CONTINUED SAFETY, REPLACE SAFETY CRITICAL COMPONENTS ONLY WITH MANUFACTURER'S RECOMMENDED PARTS
 AVERTISSEMENT:  ET  , ILS INDIQUENT LES COMPOSTANTS CRITIQUES DE SÉCURITÉ, POUR MAINTENIR LE DEGRÉ DE SÉCURITÉ DE L'APPAREIL, NE REMPLACER QUE DES PIÈCES RECOMMANDÉES PAR LE FABRICANT

NOTE UNLESS ALL RE ALL CA

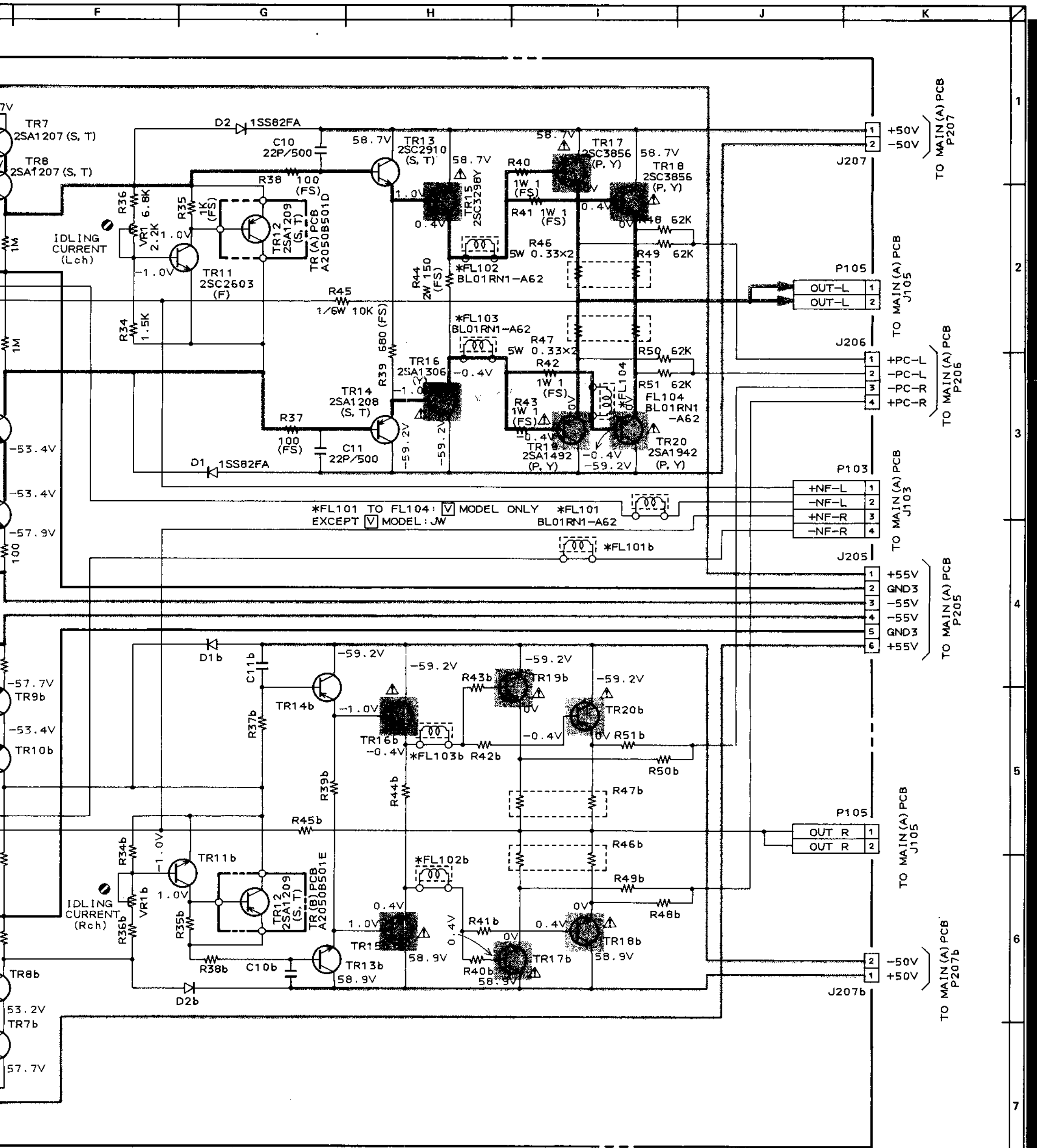

*FL101 TO FL104: MODEL ONLY *FL101 BL01RN1-A62
 EXCEPT MODEL: JW

NOTE
 UNLESS OTHERWISE SPECIFIED
 ALL RESISTORS IN OHMS 1/4W(J)
 ALL CAPACITORS IN μ F125W(J)

*INDICATED VOLTAGES ARE MESURED
 IN NO SIGNAL INPUT AND
 VOLUME IS MINIMUM MODE.

AM-93
 POWER AMP PCB
 SCHEMATIC DIAGRAM
 NO.5-2 A205002M

SAFETY CRITICAL
 REDUCED SAFETY,
 ALL COMPONENTS
 MUST BE RECOMMENDED

DIQUENT LES
 DE SÉCURITÉ.
 RÉ DE SÉCURITÉ
 ACER QUE DES
 PAR LE FABRICANT

1
 2
 3
 4
 5
 6
 7
 8

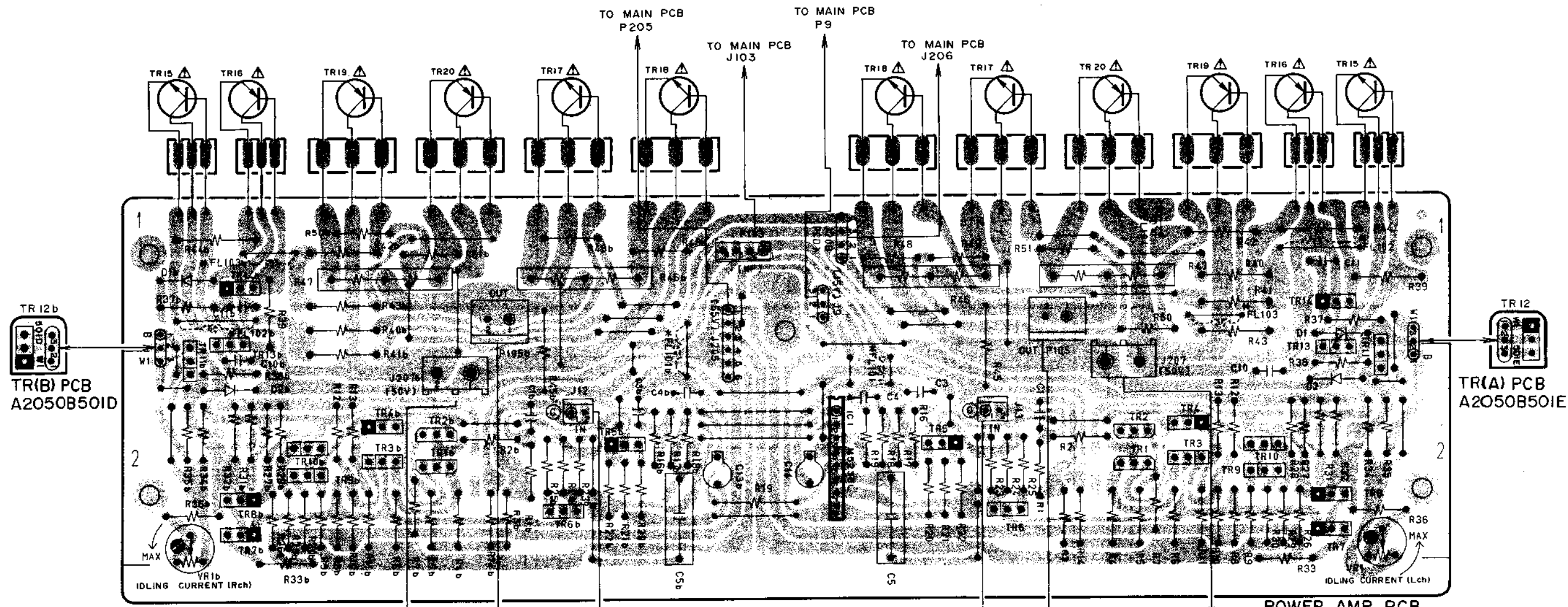

S D
 ● ● ● FET
 B ● ● PNP TRANSISTOR
 B ● ● NPN TRANSISTOR
 * Indicated $\sqrt{\square}$ are \square model only

LOCATION OF COMPONENTS

IC	TRANSISTOR	CONNECTOR
IC 1.....C2	TR1.....B2	J12b.....E2
IC 1.....C2	TR1b.....E2	J13.....C2
	TR2.....B2	J207.....B2
	TR2b.....E2	J207b.....E2
	TR3.....B2	P103.....D1
	TR3b.....E2	P105.....B1
	TR4.....B2	P105b.....E1
	TR4b.....E2	
	TR5.....C2	
	TR5b.....D2	
	TR6.....C2	
	TR6b.....E2	
	TR7.....A2	
	TR7b.....F2	
	TR8.....A2	
	TR8b.....F2	
	TR9.....A2	
	TR9b.....F2	
	TR10.....A2	
	TR10b.....F2	
	TR11.....A2	
	TR11b.....F2	
	TR13.....A2	
	TR13b.....F1	
	TR14.....A1	
	TR14b.....F1	
	TR15.....A1	
	TR15b.....F1	
	TR16.....A1	
	TR16b.....F1	
	TR17.....C1	
	TR17b.....D1	
	TR18.....C1	
	TR18b.....D1	
	TR19.....B1	
	TR19b.....E2	
	TR20.....B1	
	TR20b.....E2	

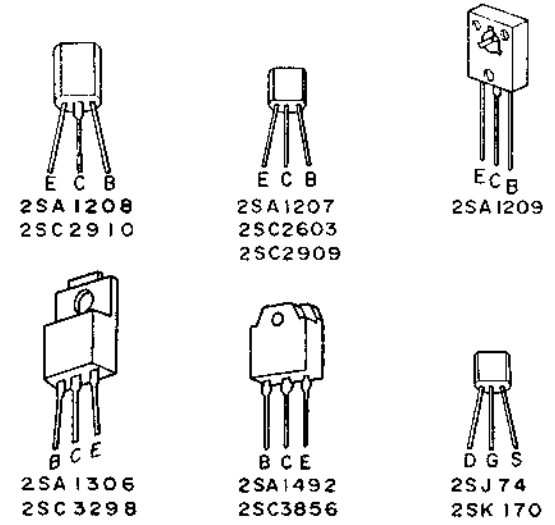

WARNING: Δ INDICATES SAFETY CRITICAL COMPONENTS. FOR CONTINUED SAFETY, REPLACE SAFETY CRITICAL COMPONENTS ONLY WITH MANUFACTURER'S RECOMMENDED PARTS.
 AVERTISSEMENT: Δ IL INDIQUE LES COMPOSANTS CRITIQUES DE SÉCURITÉ. POUR MAINTENIR LE DEGRÉ DE SÉCURITÉ DE L'APPAREIL, NE REMPLACER QUE DES PIÈCES RECOMMANDÉES PAR LE FABRICANT.

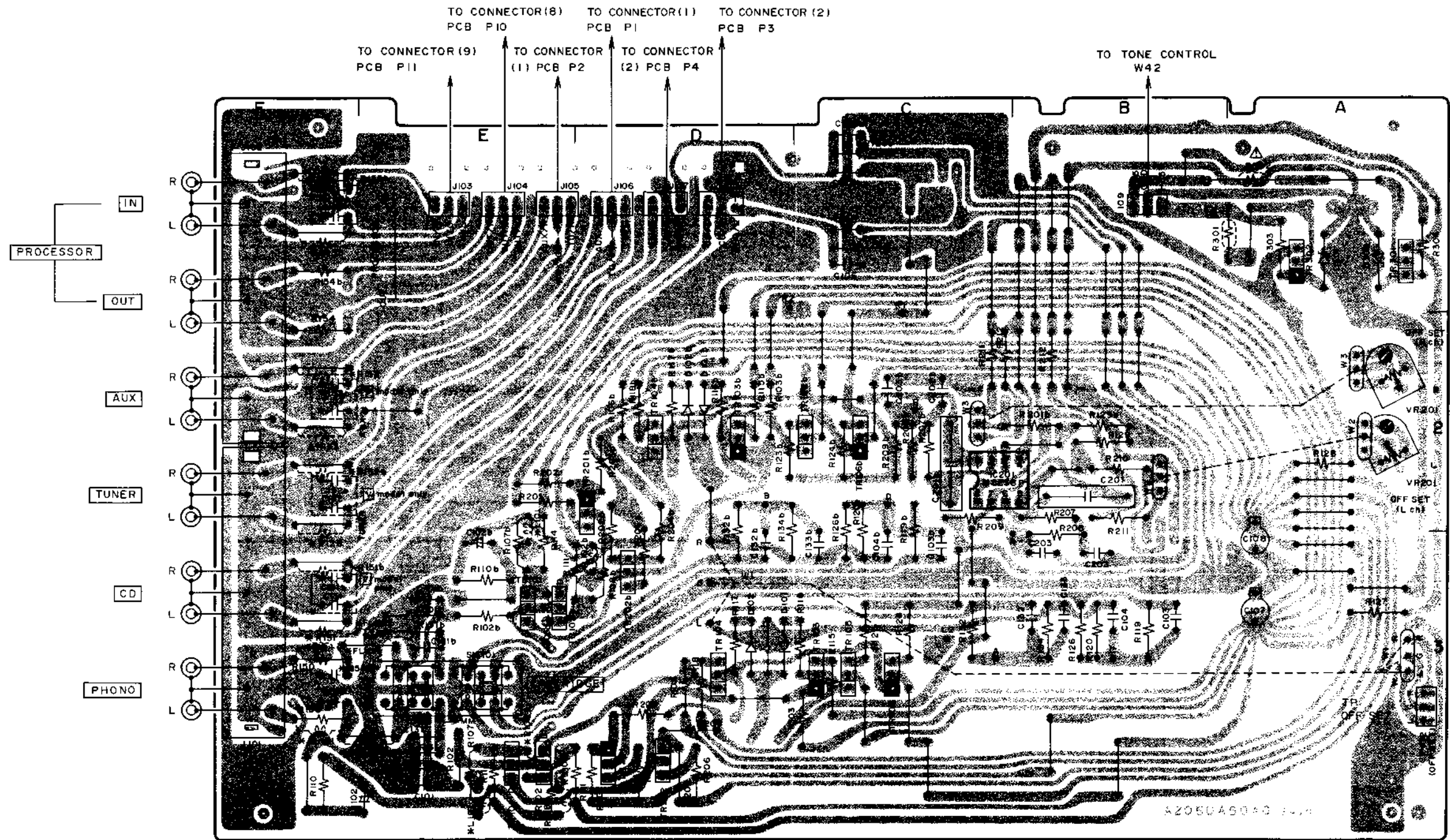

EQUALIZER PCB A2050A5040

* Indicated  are  model only

WARNING  INDICATES SAFETY CRITICAL COMPONENTS FOR CONTINUED SAFETY. REPLACE SAFETY CRITICAL COMPONENTS ONLY WITH MANUFACTURER'S RECOMMENDED PARTS.
 AVERTISSEMENT.  IL INDIQUE LES COMPOSANTS CRITIQUES DE SECURITE POUR MAINTENIR LE DEGRE DE SECURITE DE L'APPAREIL. NE REMPLACER QUE DES PIECES RECOMMANDEES PAR LE FABRICANT

LOCATION OF COMPONENTS

IC	CONNECTOR	TRANSISTOR
IC201.....C2	J101.....F3	TR 101.....E3
	J102.....F1	TR 101b.....E3
	J103.....E1	TR 102.....E3
	J104.....E1	TR 102b.....E3
	J105.....E1	TR 103.....C3
	J106.....D1	TR 103b.....D2
	J107.....D1	TR 104.....D3
	J108.....D1	TR 104b.....D2
	J109.....B1	TR 105.....C3
PI01.....C1	PI01.....C1	TR 105b.....C2
PI02.....A3	PI02.....A3	TR 106.....C3
		TR 106b.....C2
		TR 201.....D3
		TR 201b.....D2
		TR 202.....D3
		TR 202b.....D3
		TR 301.....A1
		TR 302.....A1

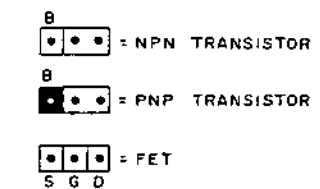
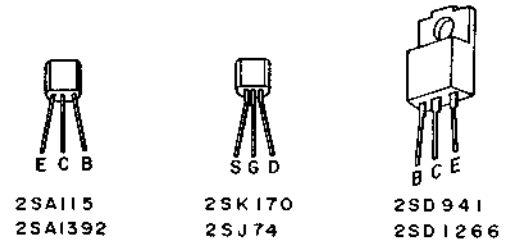

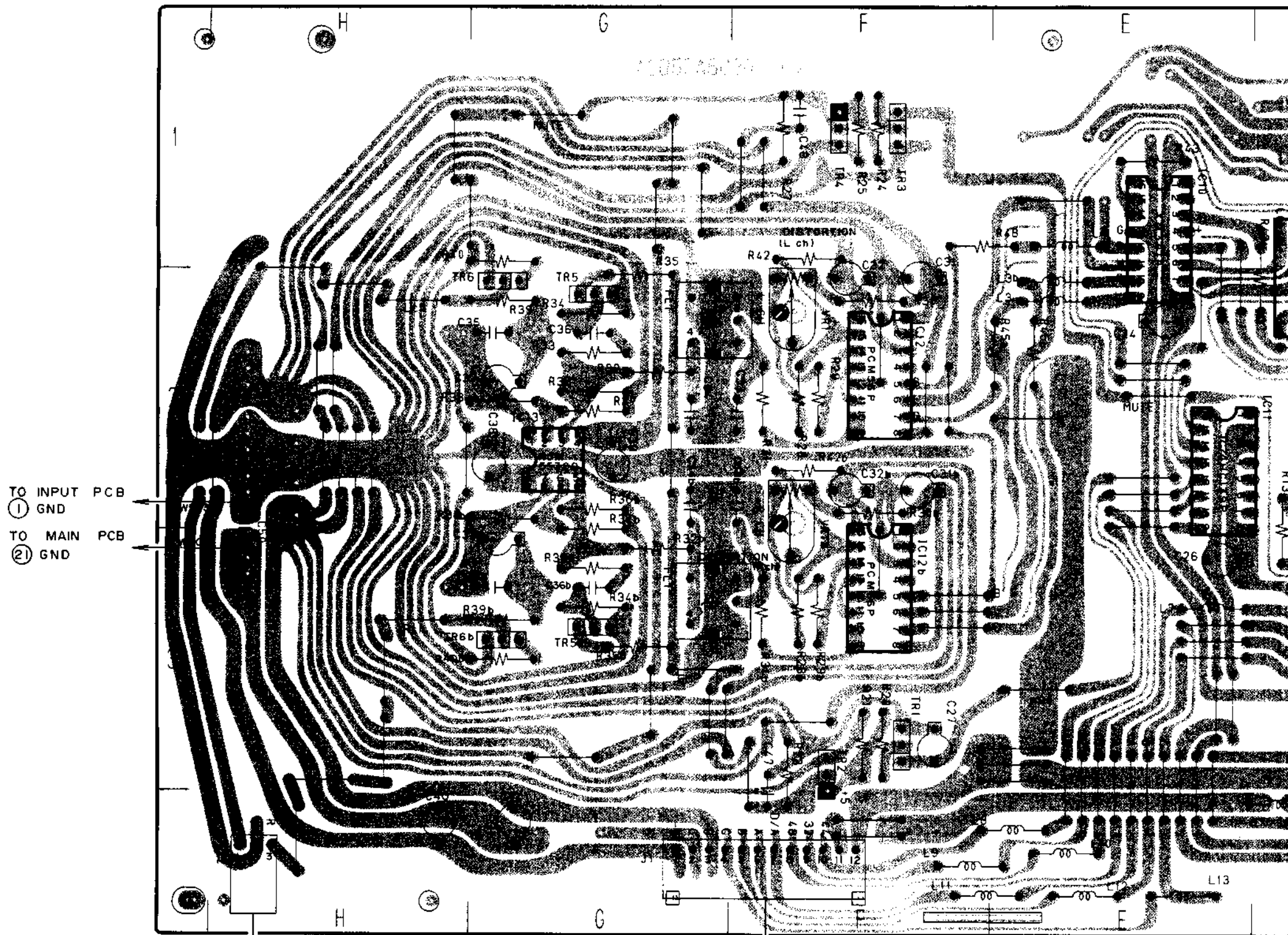

TO INPUT PCB
 ① GND
 TO MAIN PCB
 ② GND

TO REC SELECTOR PCB
 W35

TO CONNECTOR (7) PCB
 P9

LOCATION OF COMPONENTS

IC	CONNECTOR
IC3.....C2	J1.....
IC4.....C1	J2.....
IC5.....D3	J3.....
IC6.....C3	J4.....
IC7.....D2	J5.....
IC9.....D1	J6.....
IC10.....E1	J7.....
IC11.....E1	J8.....
IC12.....F2	
IC12b.....F3	
IC13.....G2	

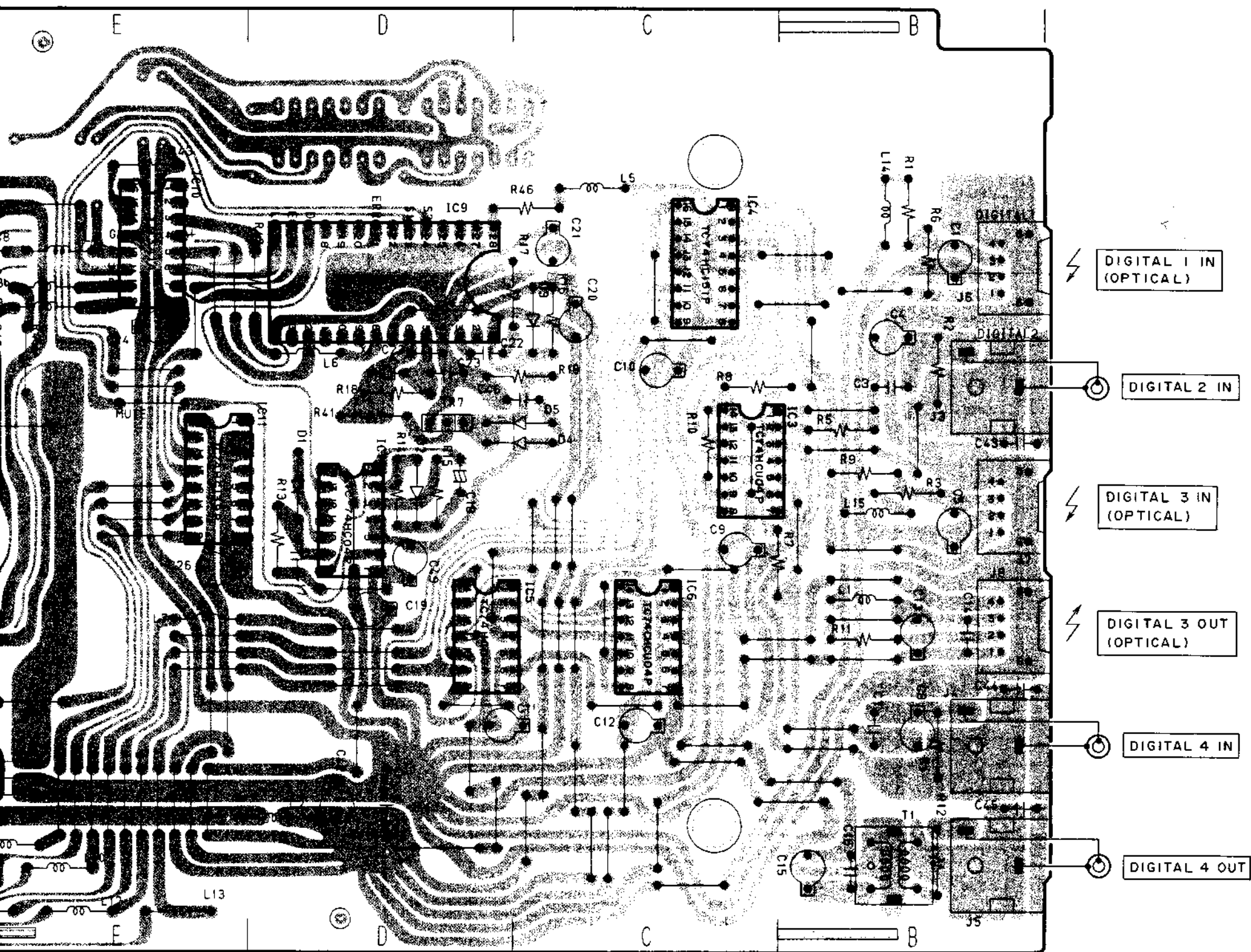

DAC PCB A2050A5020

LOCATION OF COMPONENTS

IC	CONNECTOR	TRANSISTOR
IC3.....C2	J1.....F3	TR1.....F3
IC4.....C1	J2.....H3	TR2.....F3
IC5.....D3	J3.....B2	TR3.....F1
IC6.....C3	J4.....B3	TR4.....F1
IC7.....D2	J5.....B3	TR5.....G2
IC9.....D1	J6.....B1	TR5b.....G3
IC10.....E1	J7.....B2	TR6.....G2
IC11.....E1	J8.....B3	TR6b.....G3
IC12.....F2		TR7.....D2
IC12b.....F3		
IC13.....G2		

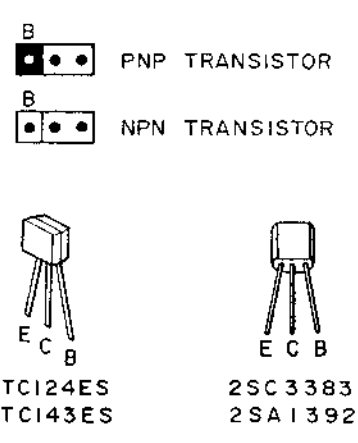

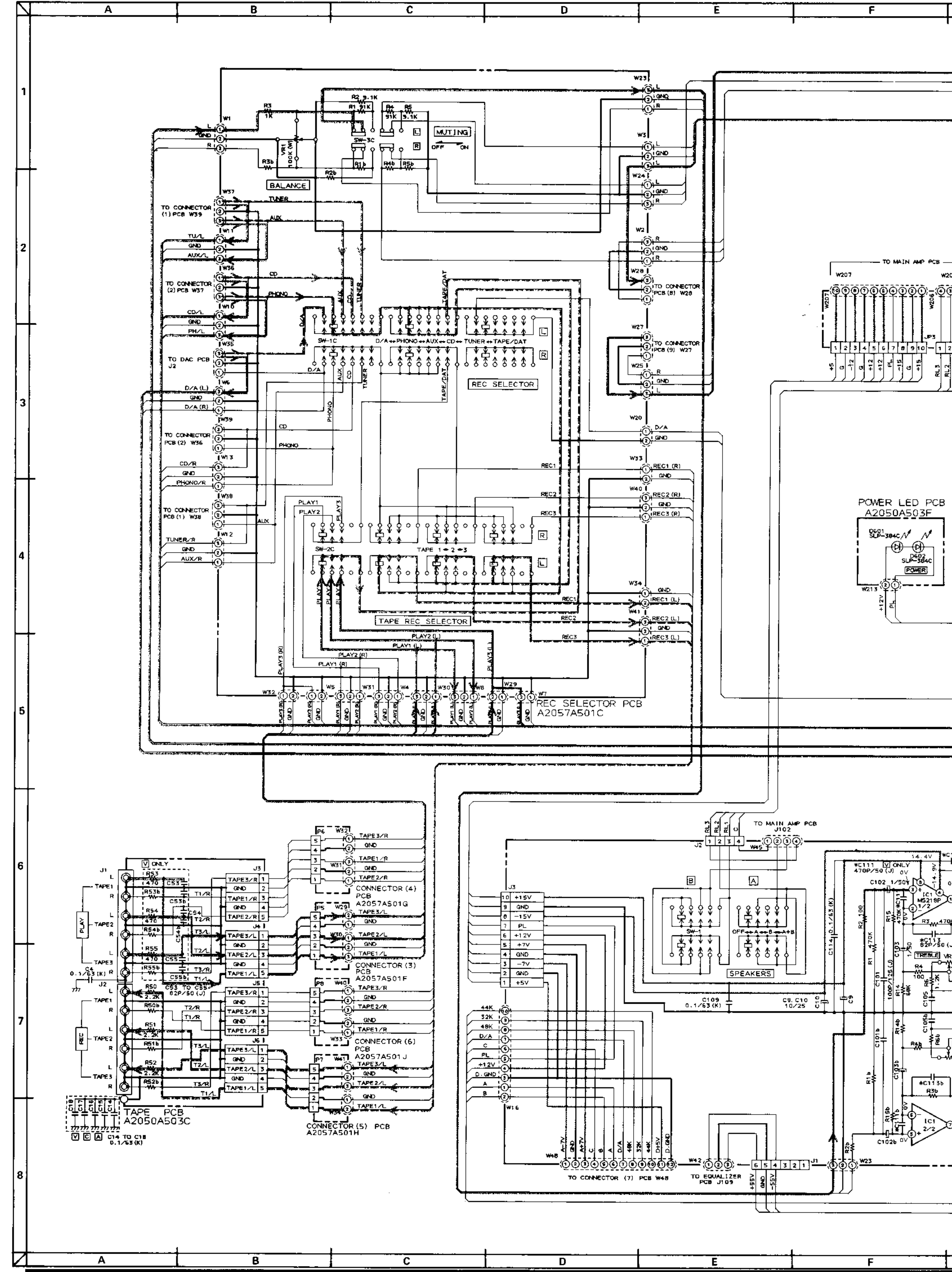

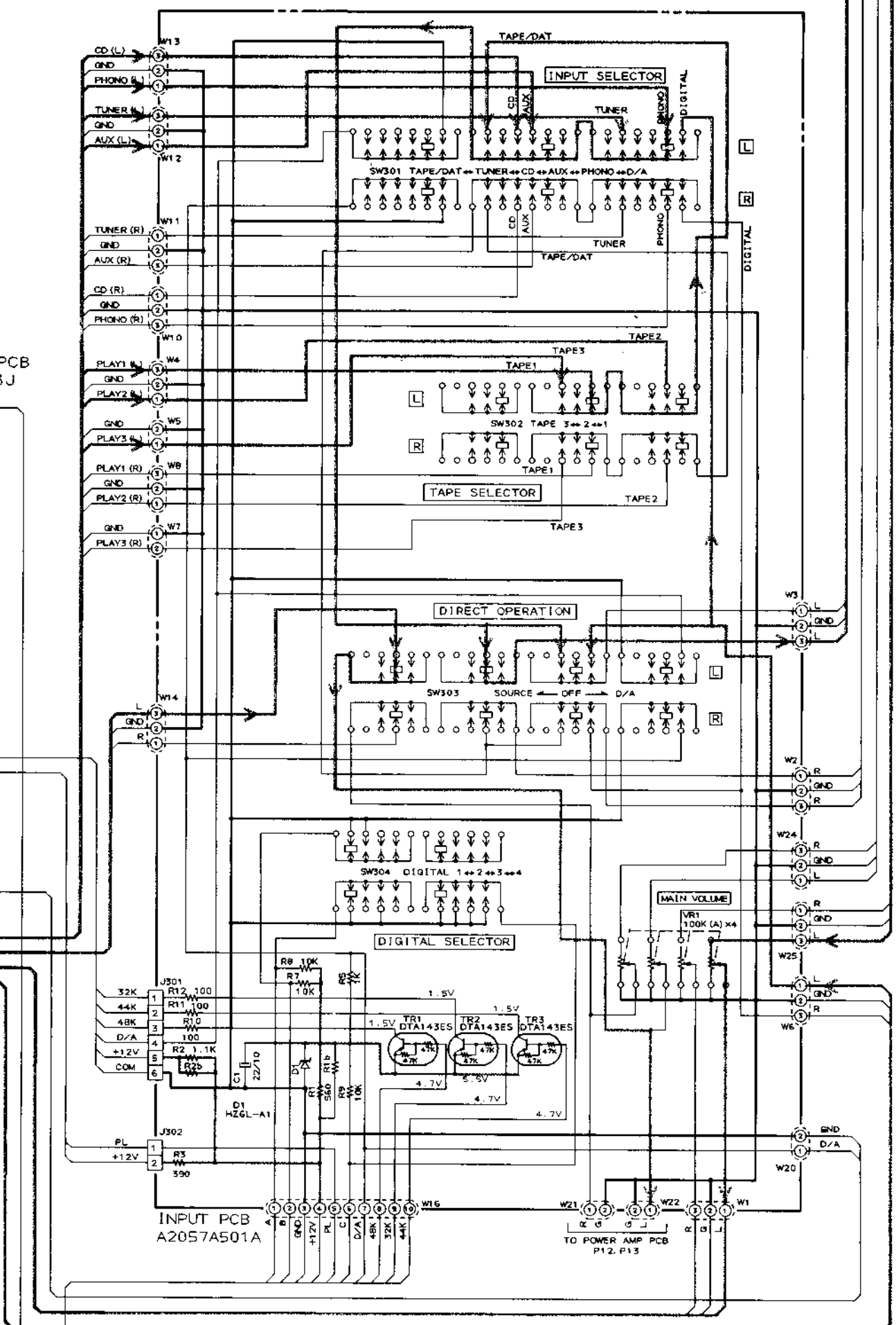
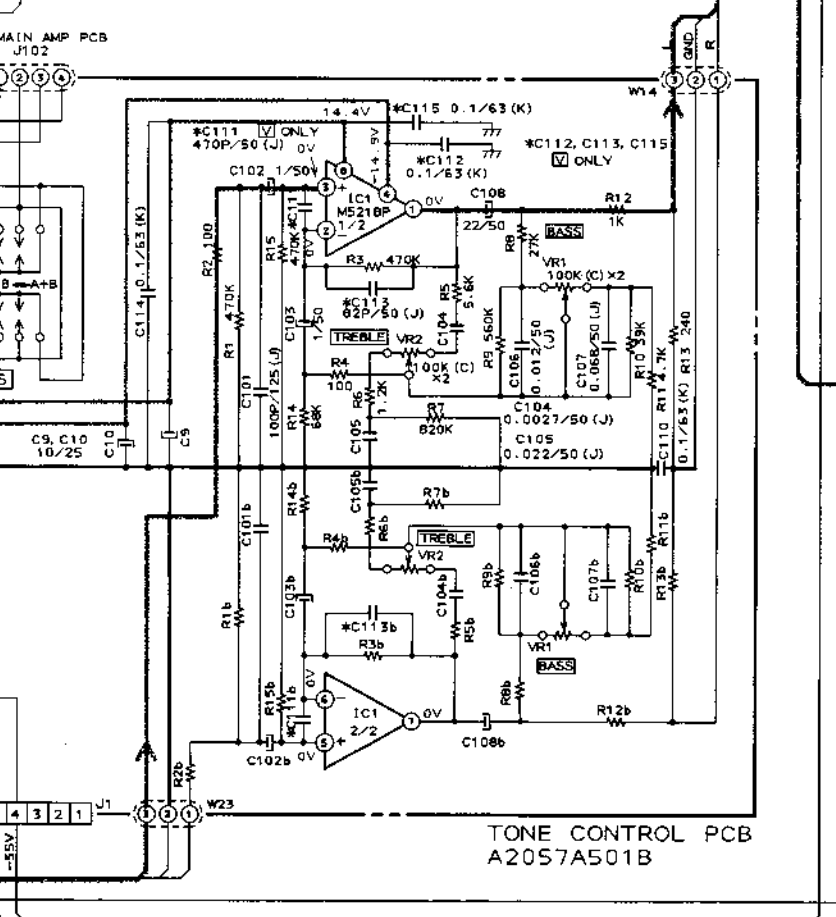
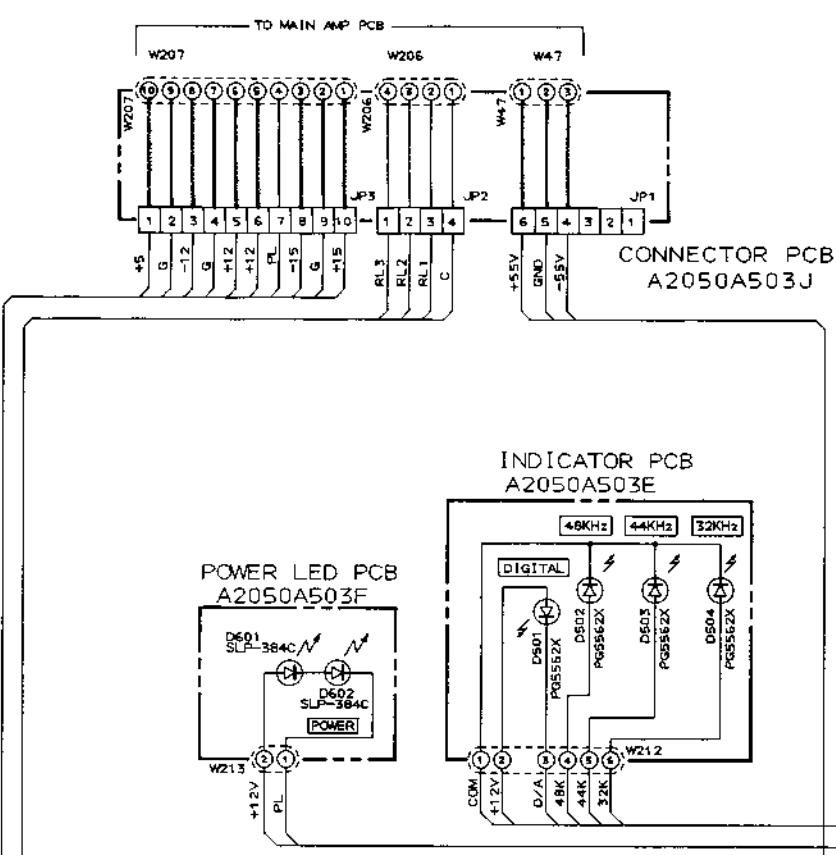

*INDICATED VOLTAGES ARE MESURED IN NO SIGNAL INPUT.

----- B (POWER SUPPLY) LINE

----- SIGNAL LINE

----- REC OUT SIGNAL LINE (INDICATED LEFT CHANNEL ONLY)

NOTE
UNLESS OTHERWISE SPECIFIED:
ALL RESISTORS IN OHMS 1/4W (J)
ALL CAPACITORS IN μF 25WV (M)

AM-93
REC SERECTOR &
INPUT & TONE PCB
SCHEMATIC DIAGRAM
NO.5-5 A205005M

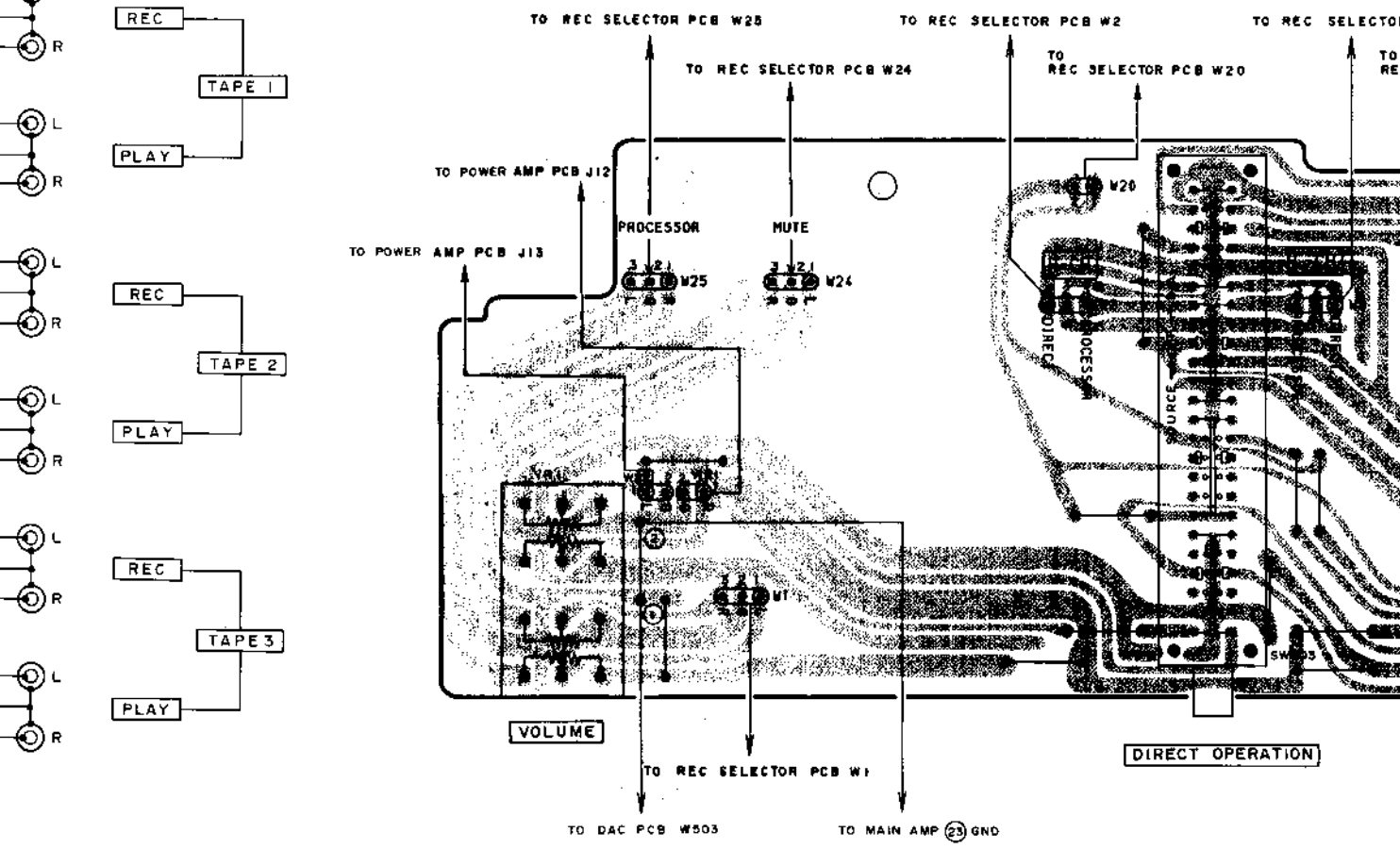
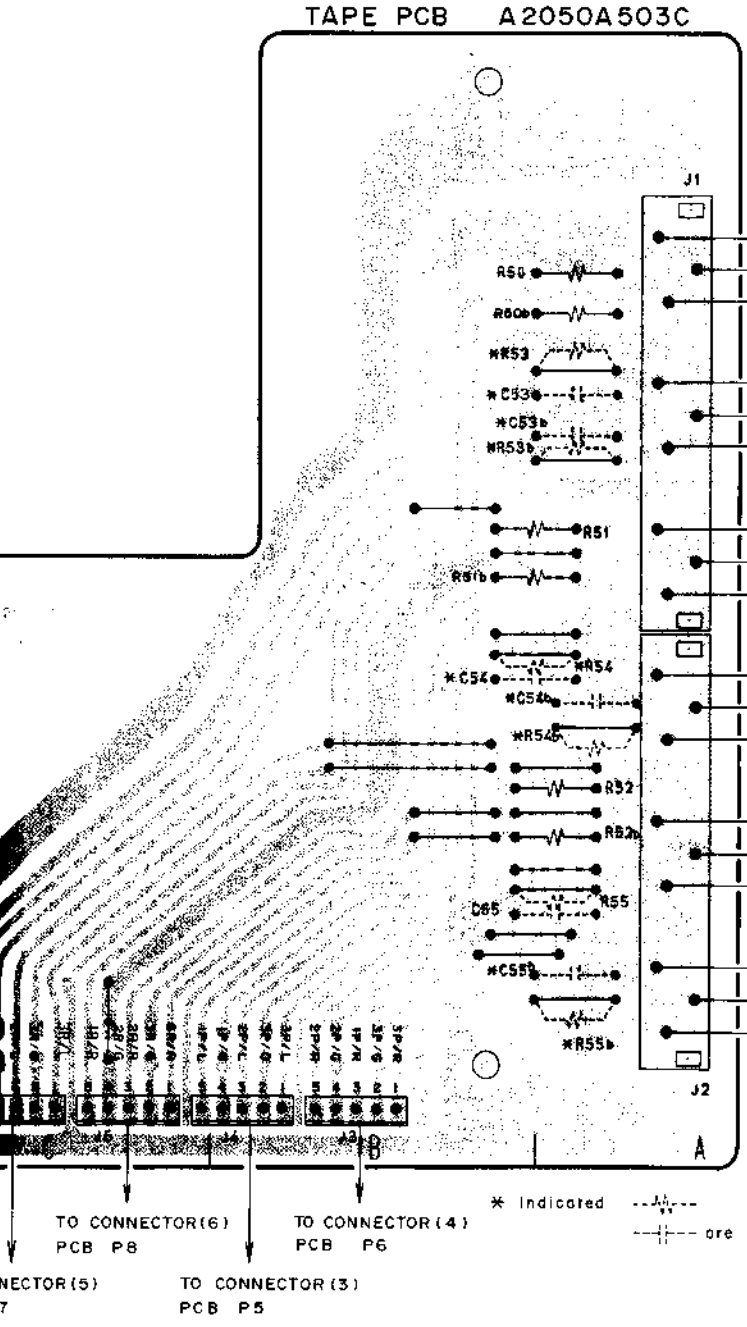
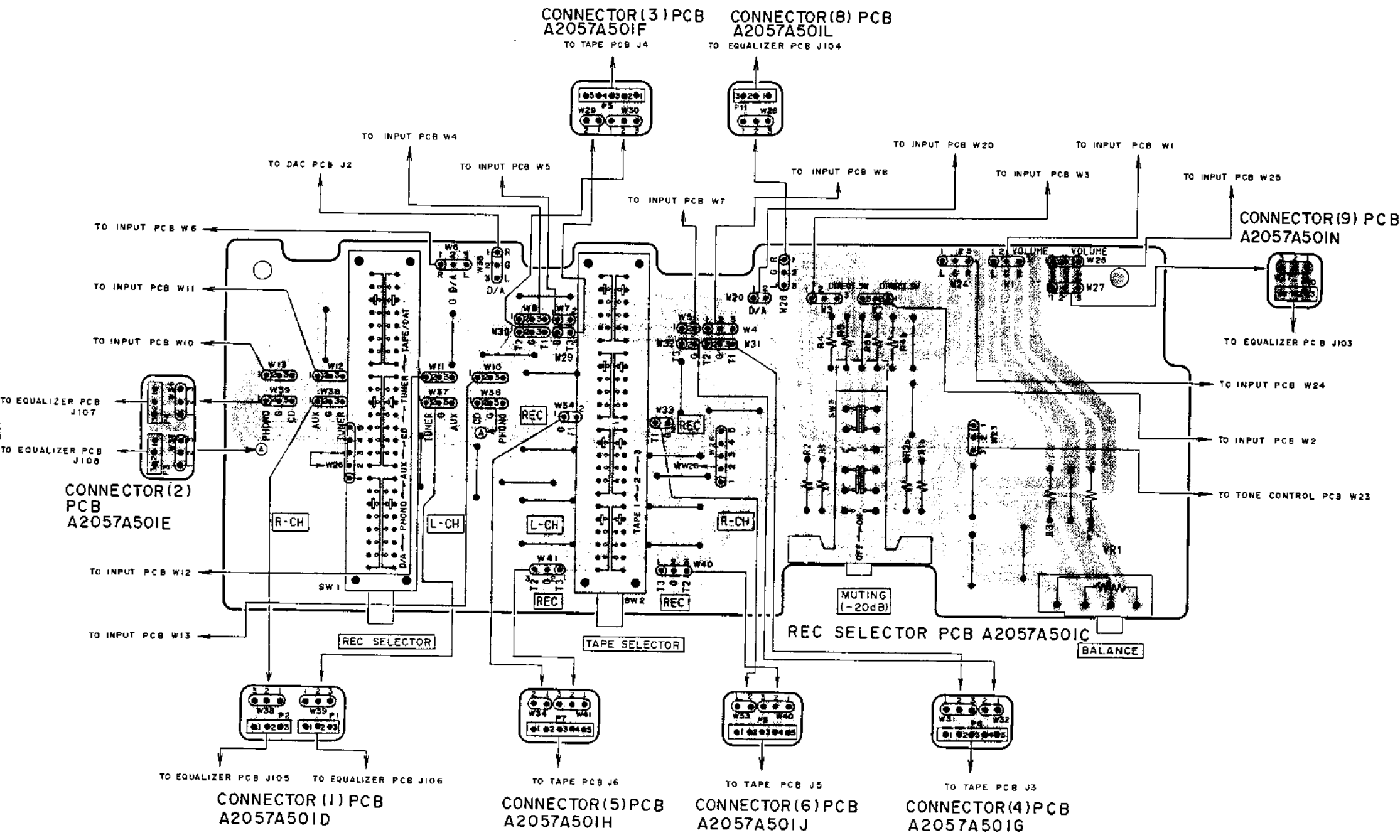

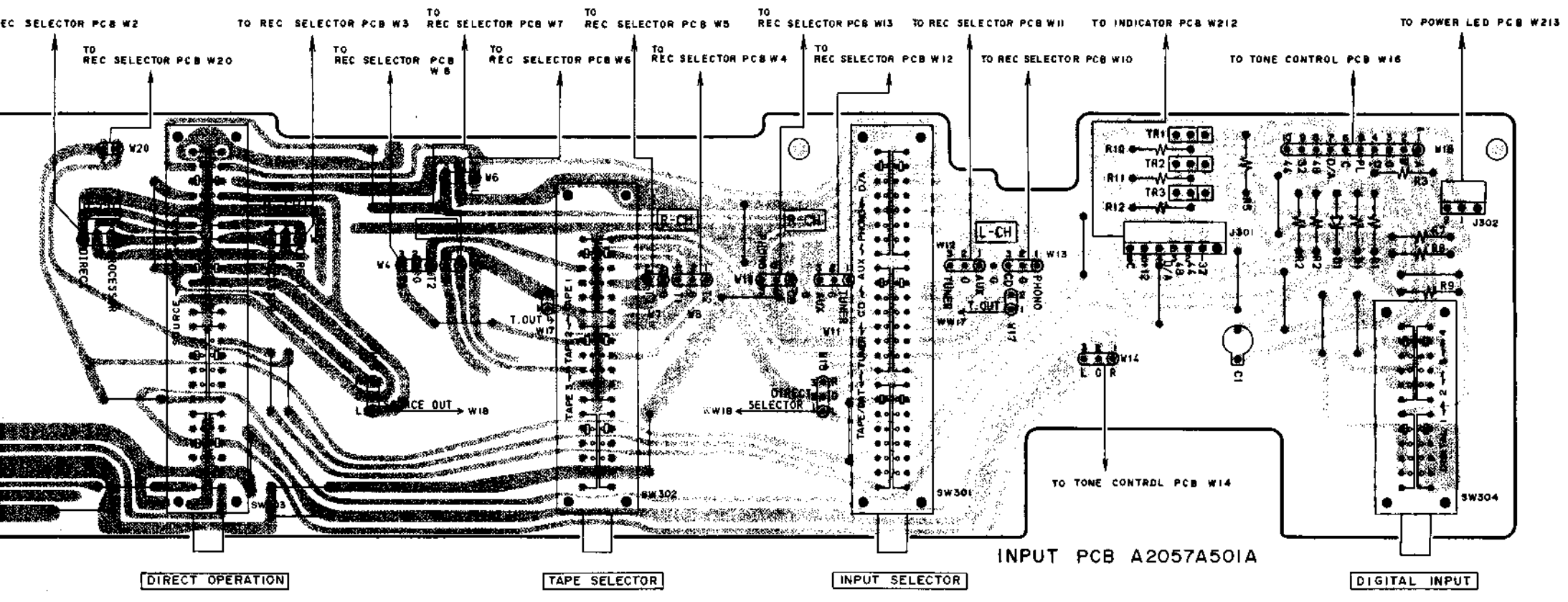
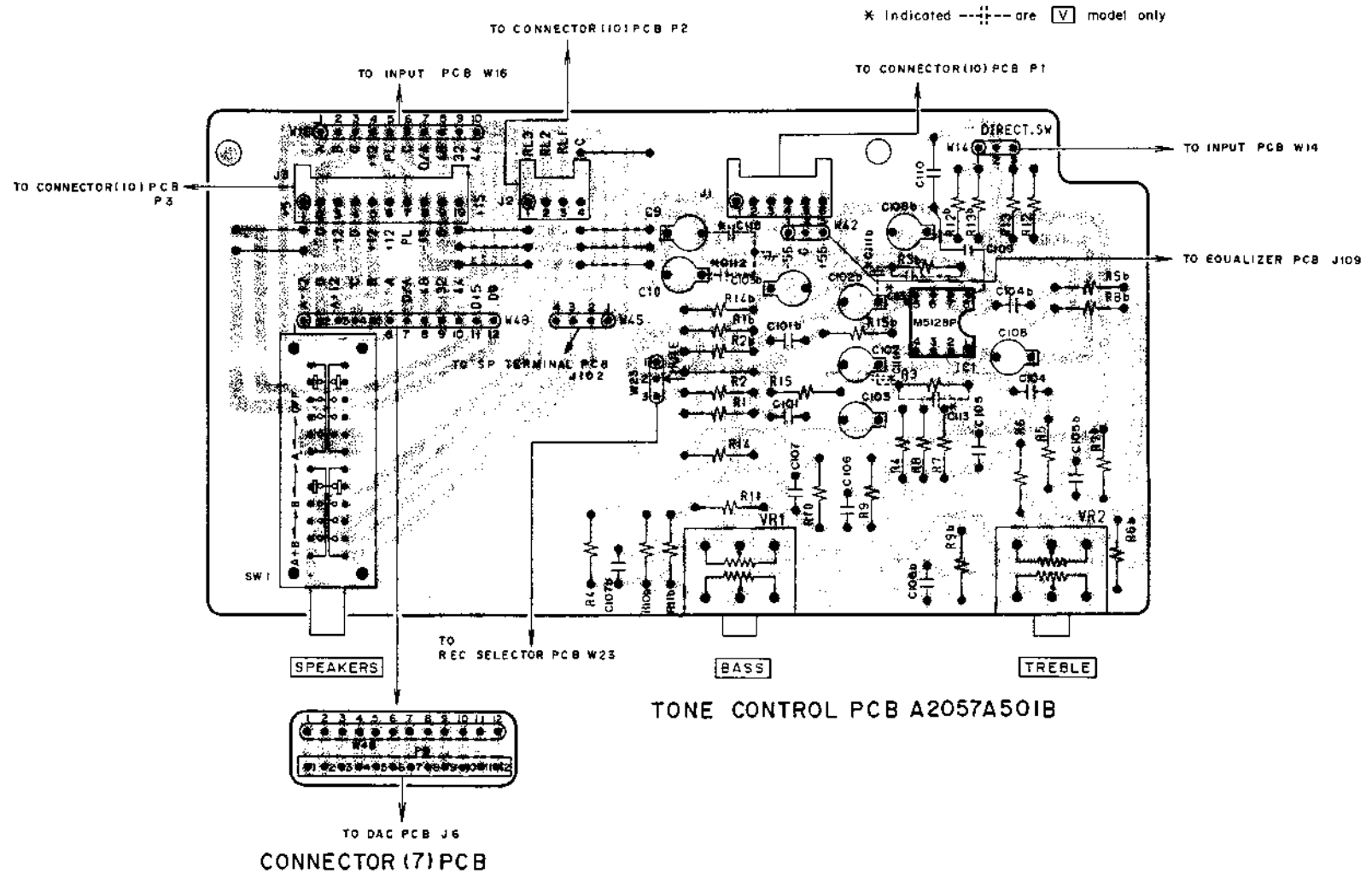
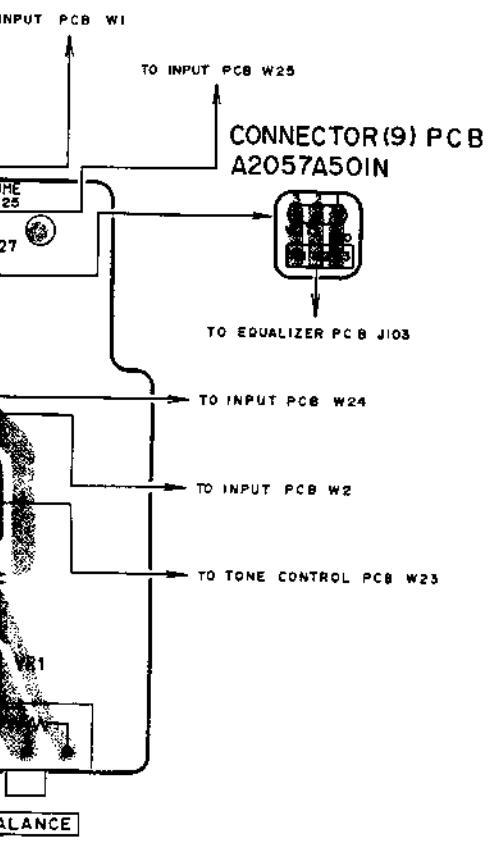

23 GND

••• = NPN TRANSISTOR



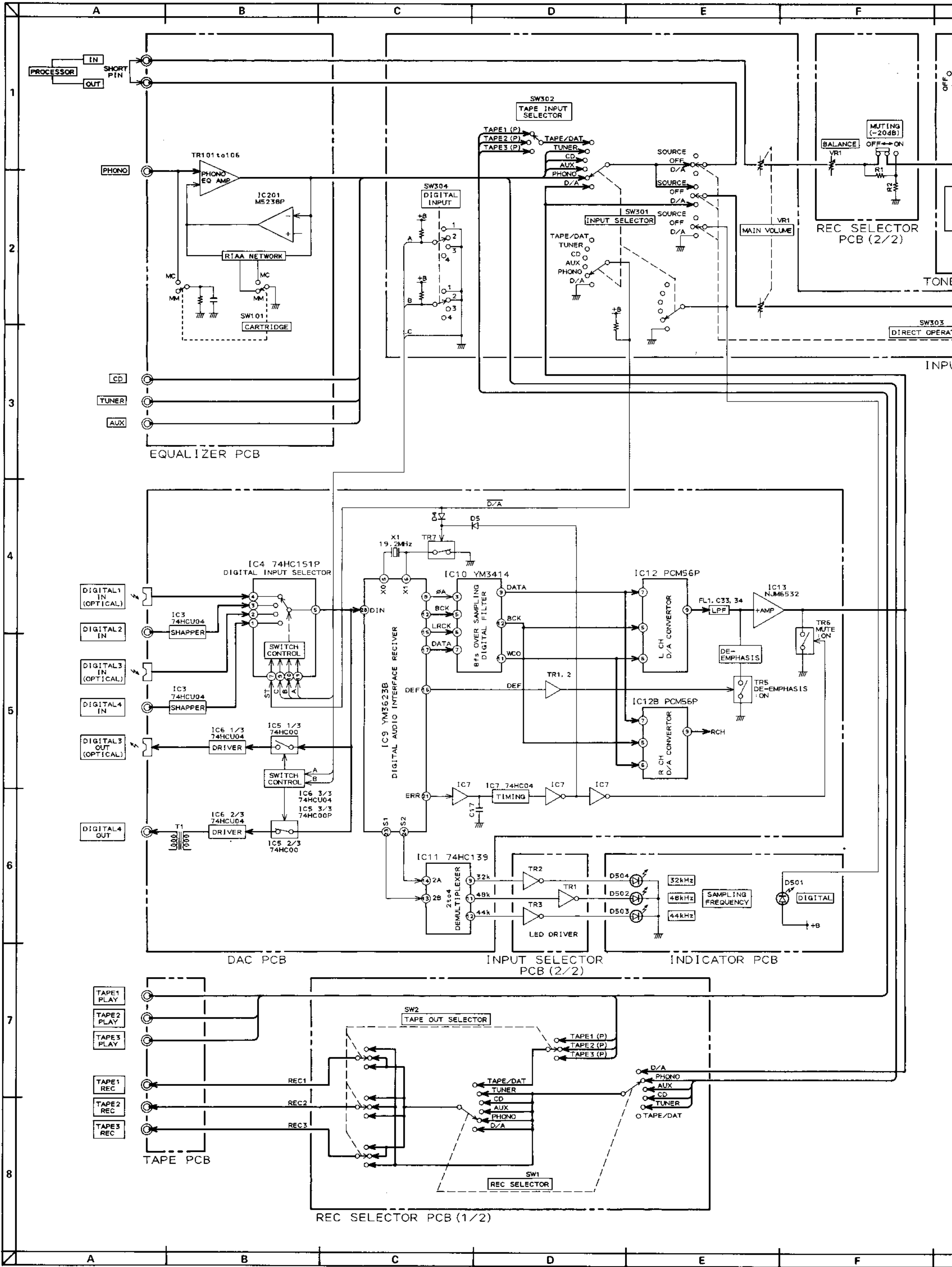

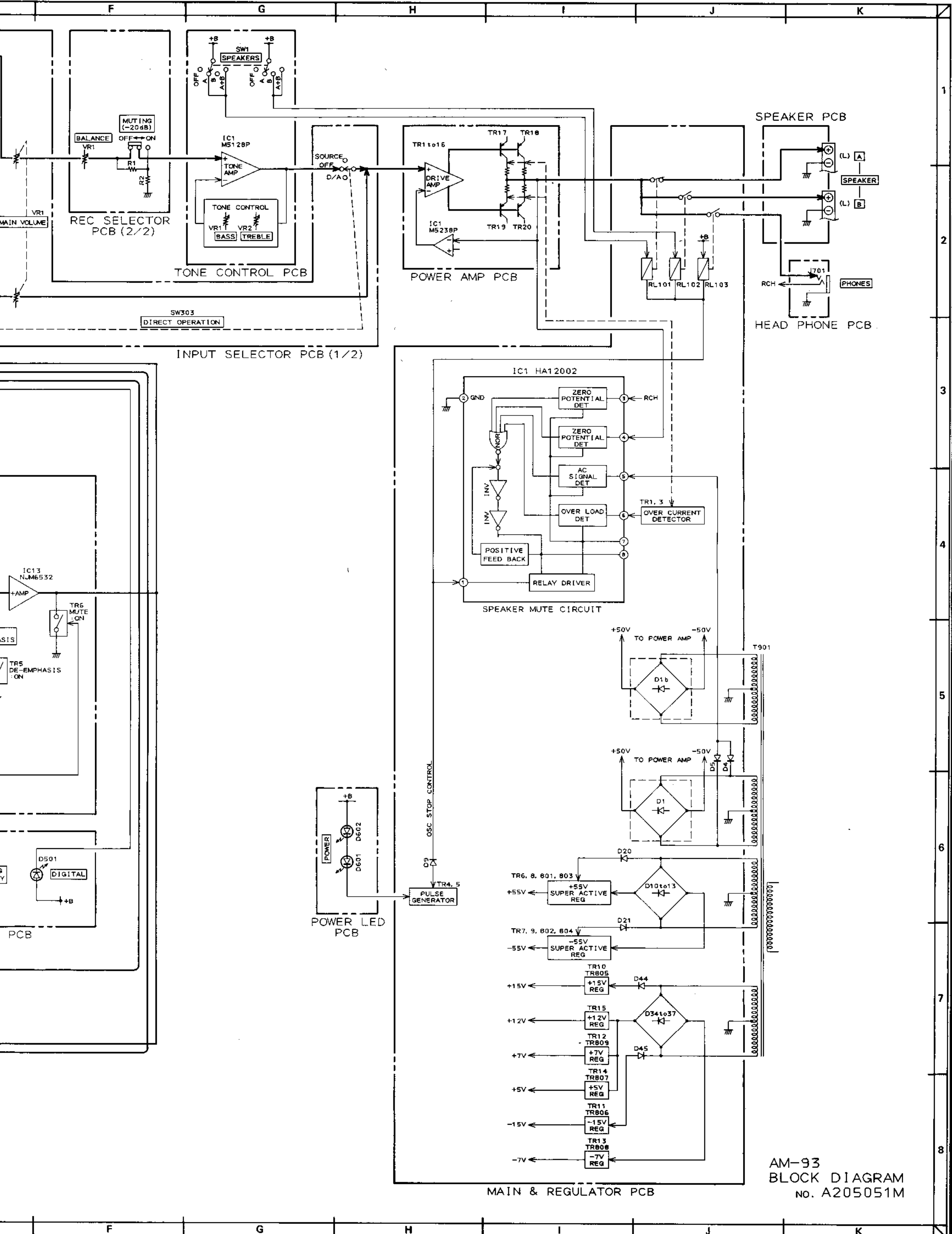

INPUT SELECTOR PCB (1/2)

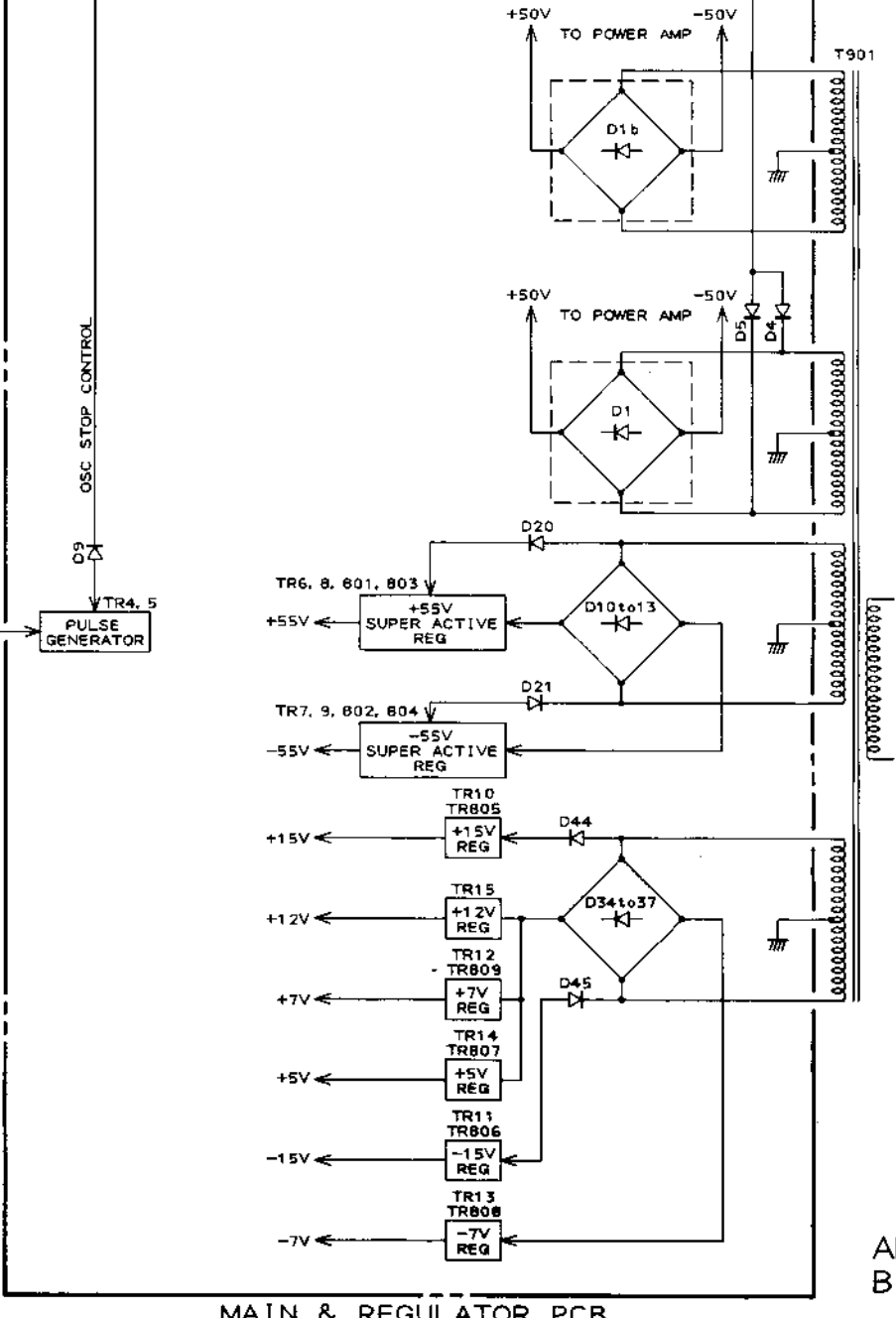
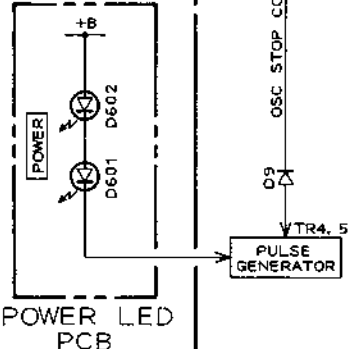
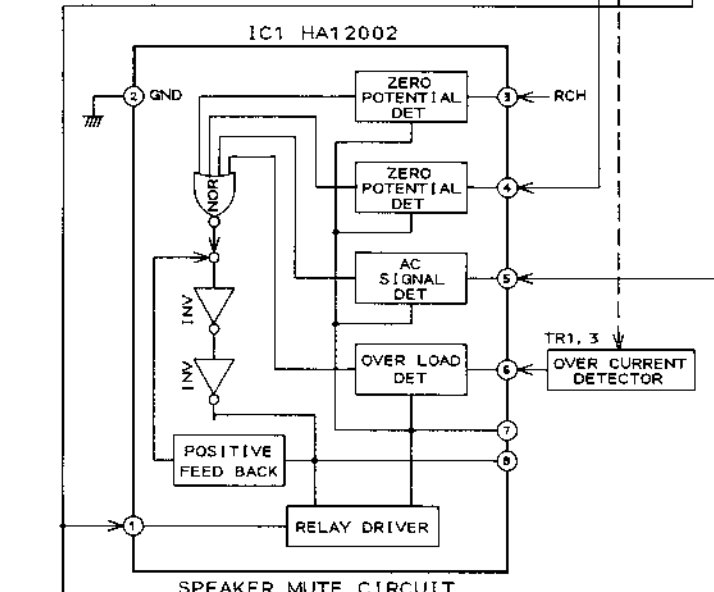

AM-93
BLOCK DIAGRAM
NO. A205051M