

AKAI SERVICE MANUAL

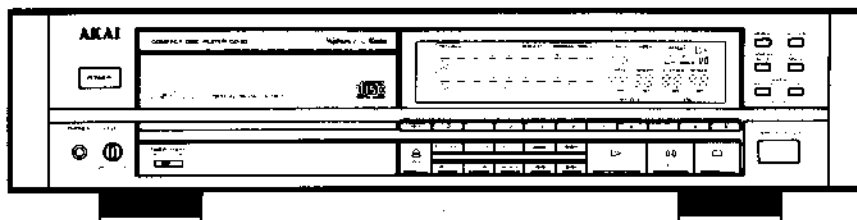

COMPACT DISC PLAYER MODEL CD-93



I. SPECIFICATIONS

System	Compact disc player	Headphone output level/	
Pick-up system	3 beam Laser pick up	Impedance	28 mW/32 ohms
Sampling frequency	44.1 kHz	Spindle motor	Brush-less D.D. motor
Digital filter	18 bit, 4 times over sampling	Power requirements	120 V, 60 Hz for USA & Canada
D/A converter	16 bit linear		220 V, 50 Hz for Europe except UK
Error correction system	Cross Interleave Reed Solomon		240 V, 50 Hz for UK & Australia
Number of channels	2 channels (Stereo)		110V-120V/220V-240V, 50 Hz/60 Hz convertible for other countries
Frequency response	2 Hz to 20 kHz \pm 0.3 dB	Dimensions	460 (W) \times 112 (H) \times 330 (D) mm (18.1 \times 4.4 \times 13.0 inches)
Dynamic range	97 dB or more	Weight	13.6 kg (30.0 lbs)
S/N	106 dB or more		
Total harmonic distortion	0.0025% or less		
Wow & Flutter	Less than measurable limits		
Analogue output level	2 V (0 dB)		
Digital output level/			
Impedance			
Coaxial	0.5 Vp-p/75 ohms		
Optical.....	Min. -20 dBm, Max. -15 dBm, wave length 660 nm		

* For improvement purposes, specifications and design are subject to change without notice.

★ SAFETY INSTRUCTIONS

PRECAUTIONS DURING SERVICING

- Parts identified by the \triangle symbols are critical for safety. Replace only with parts number specified.
- In addition to safety, other parts and assemblies are specified for conformance with such regulations as those applying to spurious radiation. These must also be replaced only with specified replacements.
Examples: RF converters, tuner units, antenna selector switches, RF cables, noise blocking capacitors, noise blocking filters, etc.
- Use specified internal wiring. Note especially:
 - Wires covered with PVC tubing
 - Double insulated wires
 - High voltage leads
- Use specified insulating materials for hazardous live parts. Note, especially:
 - Insulation Tape
 - PVC tubing
 - Spacers (Insulating Barriers)
 - Insulation sheets for transistors
 - Plastic screws for fixing microswitch (especially in turntable)
- When replacing AC primary side components (transformers, power cords, noise blocking capacitors, etc.), wrap ends of wires securely about the terminals before soldering.

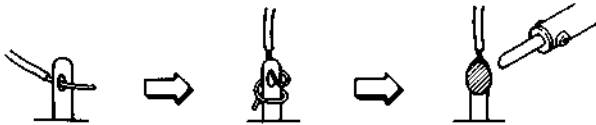

- Observe that wires do not contact heat producing parts (heatsinks, oxide metal film resistors, fusible resistors, etc.).

- Check that replaced wires do not contact sharp edged or pointed parts.
- Also check areas surrounding repaired locations.
- Use care that foreign objects (screws, solder droplets, etc.) do not remain inside the set.

SAFETY CHECK AFTER SERVICING

Confirm the specified insulation resistance between power cord plug prongs and externally exposed parts of the set is greater than 10 M ohms, but for equipment with external antenna terminals (tuner, receiver, etc.) and is intended for [C] or [A], specified insulation resistance should be headphone jacks, line-in-out jacks, etc. more than 2.2 M ohms (ground terminals, microphone jacks).

BEFORE USING THE CD PLAYER

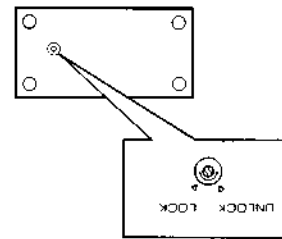

On the Transport Locking Lever

This CD player has a Transport Locking Lever located on the bottom panel. This lever locks the laser pick up mechanism to prevent vibration during transportation. Make sure to set this lever to the UNLOCK position before playback.

Raise the CD player as shown in the illustration (Front panel facing up), and then turn the Transport Locking Lever to the UNLOCK position.

When transporting the CD player

Make sure to remove the compact disc from the CD player, and reset the Transport Locking Lever to the LOCK position.

★ INFORMATION

SYMBOLS FOR PRIMARY DESTINATION

Alphabet indicates the destination of the units as listed below.

Symbols	Principal Destinations
[A]	USA
[B]	UK
[C]	Canada
[E]	Europe (except UK)
[J]	Japan
[S]	Australia
[V]	W. Germany only
[U]	Universal Area
[Y*]	Custom version

VOLTAGE CONVERSION ([U] Model only)

Before connecting the power cord, SET the VOLTAGE SELECTOR located on the rear panel with a screwdriver so that the correct voltage is indicated.

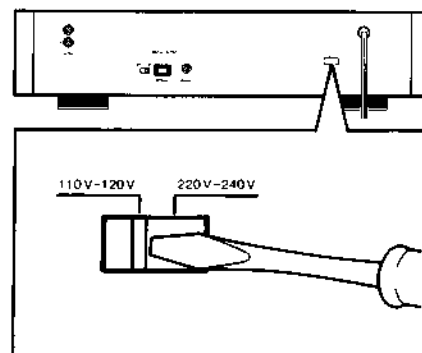

PRECAUTIONS IN REPAIRING

When repairing or adjusting the unit, please note the following points.

1. Do not put excessive pressure on the mechanical part (operation part), including the pick-up block, as extremely high mechanical precision is required in these parts.
2. When the base is removed for repair or adjustment, make sure that there are no metal objects in the narrow gap between the P.C. board or the mecha parts and the base.
3. The Micro-Computer and the CD signal processing ICs can be damaged by static electricity or leakage from a soldering iron during repairing.

While soldering, please take the precautions against leakage as in the illustration.

4. Do not loosen any screws in the pick-up block. When handling the pick-up block, please refer to the points to NOTE when replacing the pick-up block.
5. Keep safety from hazardous invisible Laser Radiation. DO NOT watch the Laser Beam (Objective Lens) directly.
6. Models for the same countries, Laser Warning Labels are affixed on the unit and inside of the unit, as shown below. Read it carefully for your safety, when repairing or adjusting the unit.

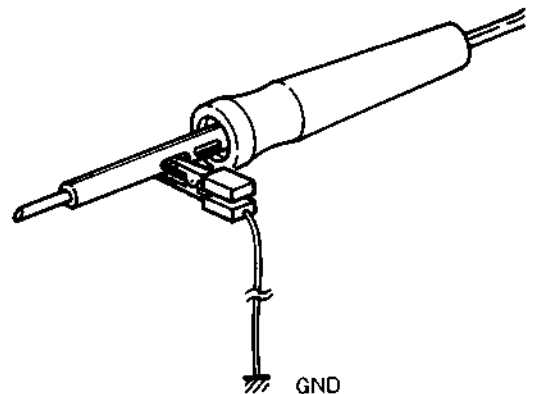

[DENMARK and U.K.]



A Label affixed on the Rear panel of the unit

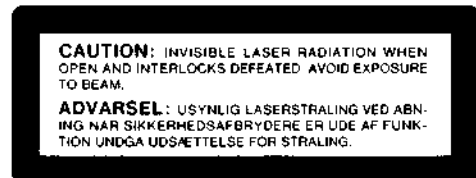

A Label affixed on the HOLDER STABILIZER the unit

[U.S.A.]

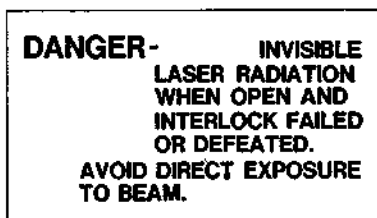

A Label printed on the Rear panel of the unit.

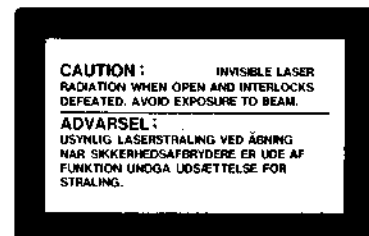

A Label affixed on the HOLDER STABILIZER the unit.

I. CONTROLS

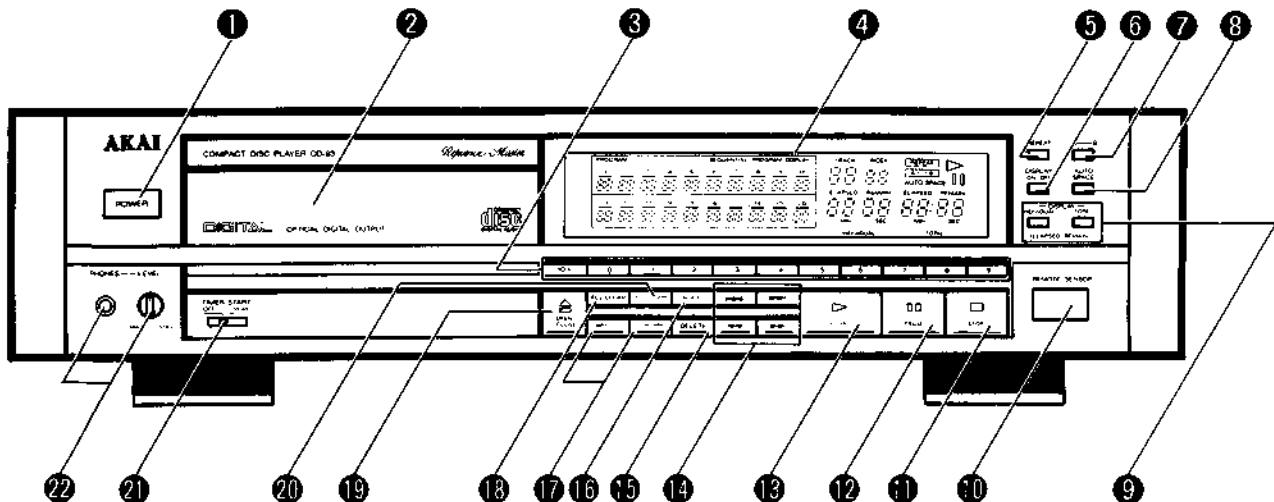

- ① **POWER Button**
To turn the power on and off.
- ② **Disc drawer**
Load a compact disc here.
- ③ **Numeric Buttons (10+ and 0 to 9)**
For direct search of the track you wish to play back and for programming for random program playback.
- ④ **FL (Fluorescent) display**
Tells you what the Akai CD player is doing.
- ⑤ **REPEAT Button**
For repeat playback of all the tracks or the random program.
- ⑥ **DISPLAY ON/OFF Button**
To turn the FL display on and off.
- ⑦ **A ↔ B Button**
For repeat playback of a specific section of the CD.
- ⑧ **AUTO SPACE Button**
To set the blank intervals between tracks to a specific time (approximately 4 seconds) for uniformity during playback.
- ⑨ **DISPLAY INDIVIDUAL and TOTAL Buttons**
To select between remaining time and elapsed time displays.
- ⑩ **REMOTE SENSOR Window**
For reception of the remote control signal.
Keep away from strong light and direct sunlight as this will interfere with the remote control function.
- ⑪ **□ STOP Button**
To stop playback.
- ⑫ **⏸ PAUSE Button**
To stop playback temporarily.
- ⑬ **▶ PLAY Button**
To start playback.
- ⑭ **Search Buttons (⏮ / ⏪ and ⏩ / ⏭)**
For manual search and to skip tracks during playback.
- ⑮ **DELETE Button**
To delete a programmed track.
- ⑯ **INDEX Button**
For index search playback.
- ⑰ **Cursor Control Buttons (← / →)**
To move the cursor during programming.
- ⑱ **ALL CLEAR Button**
To cancel all the programmed tracks.
- ⑲ **⏏ OPEN/CLOSE Button**
To open and close the disc drawer.
- ⑳ **PROGRAM Button**
For random program playback.
- ㉑ **TIMER START OFF/PLAY Switch**
For timed playback operation.
- ㉒ **PHONES Jack and LEVEL Control**
For headphone listening.

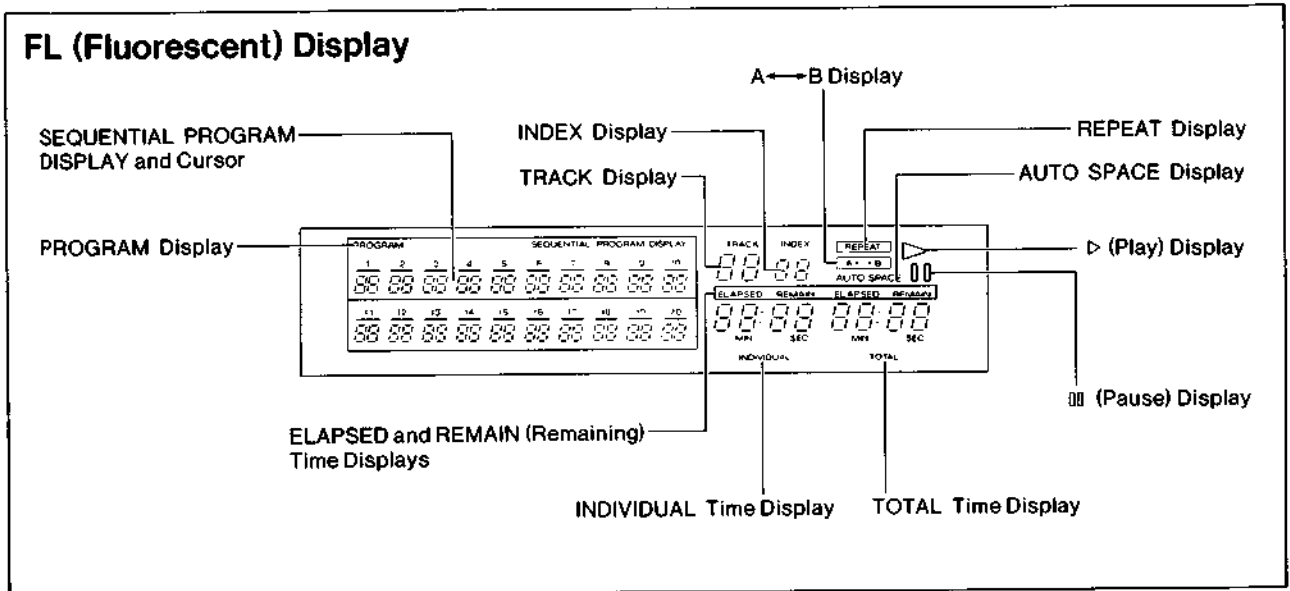

Control (CD player)

The operation buttons on the remote control unit are the same as those on the Akai CD player and can be used to conveniently control all the CD player's functions.

Transmitting window

⏏ (Open/Close) Button

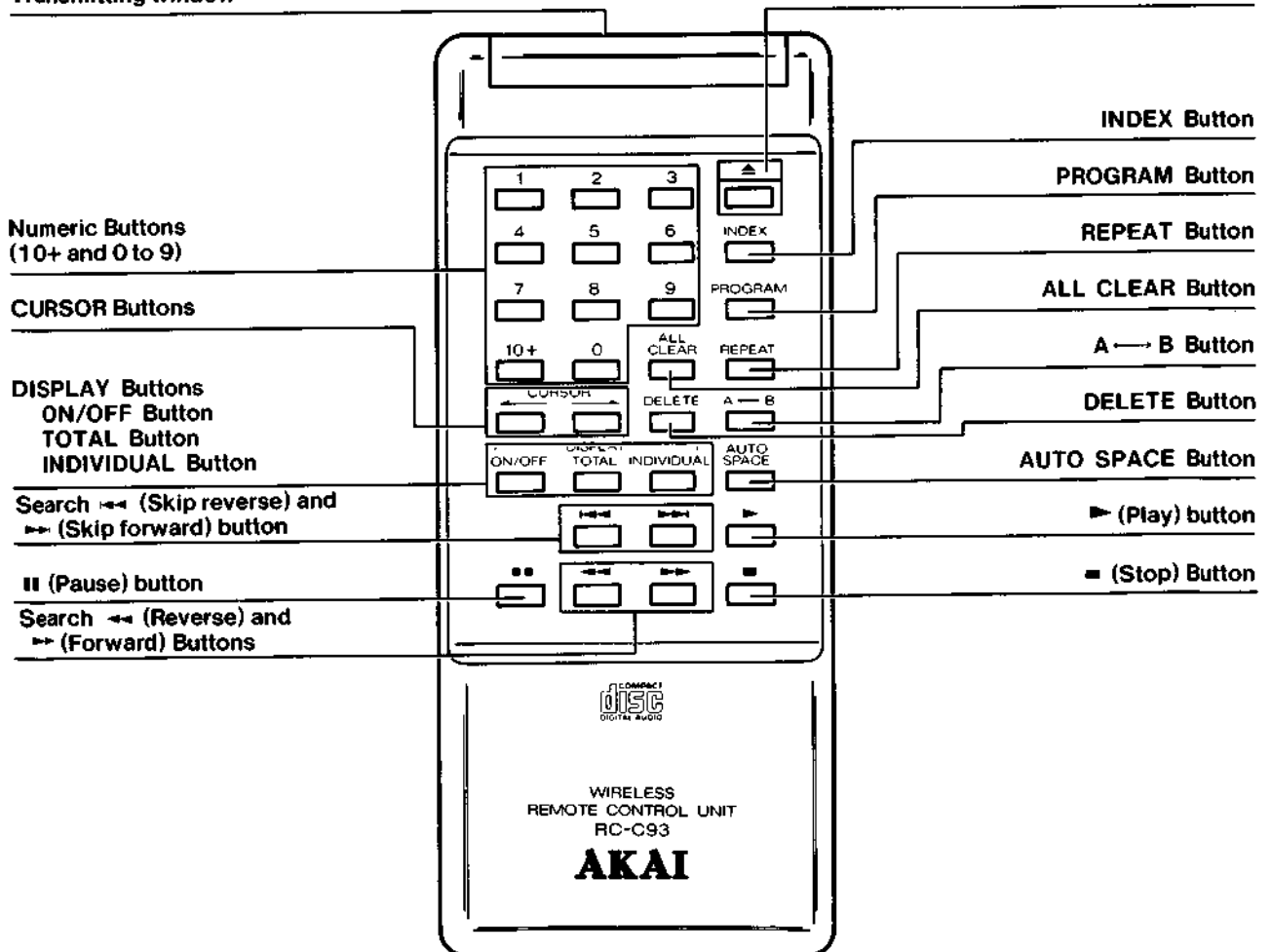

II. DISASSEMBLY

1. Removal of Upper Cover

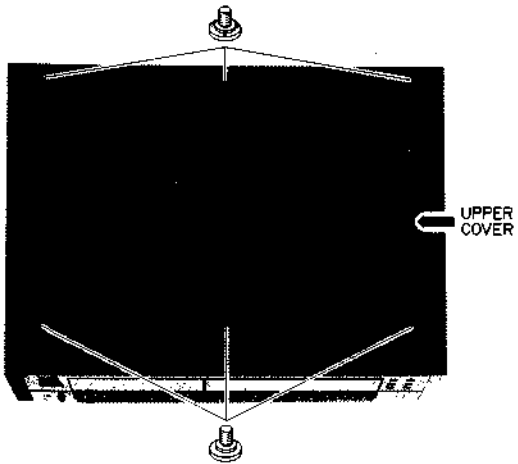

3.

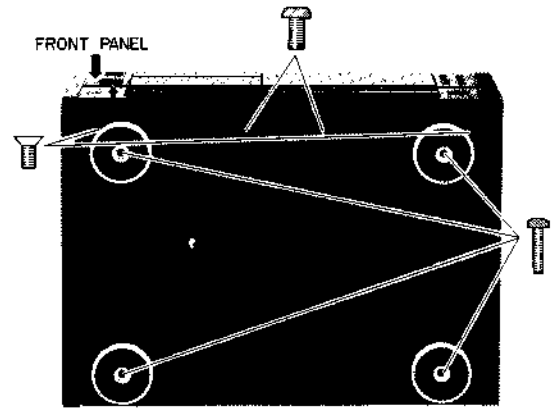

2. Removal of Front Panel

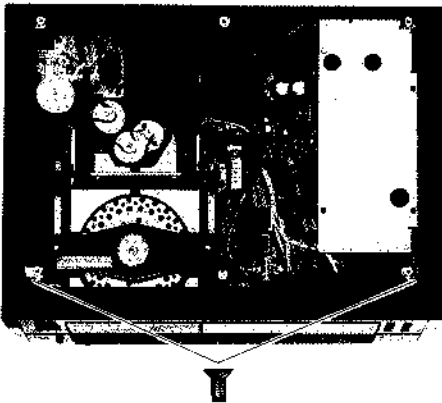

III. PRINCIPAL PARTS LOCATION

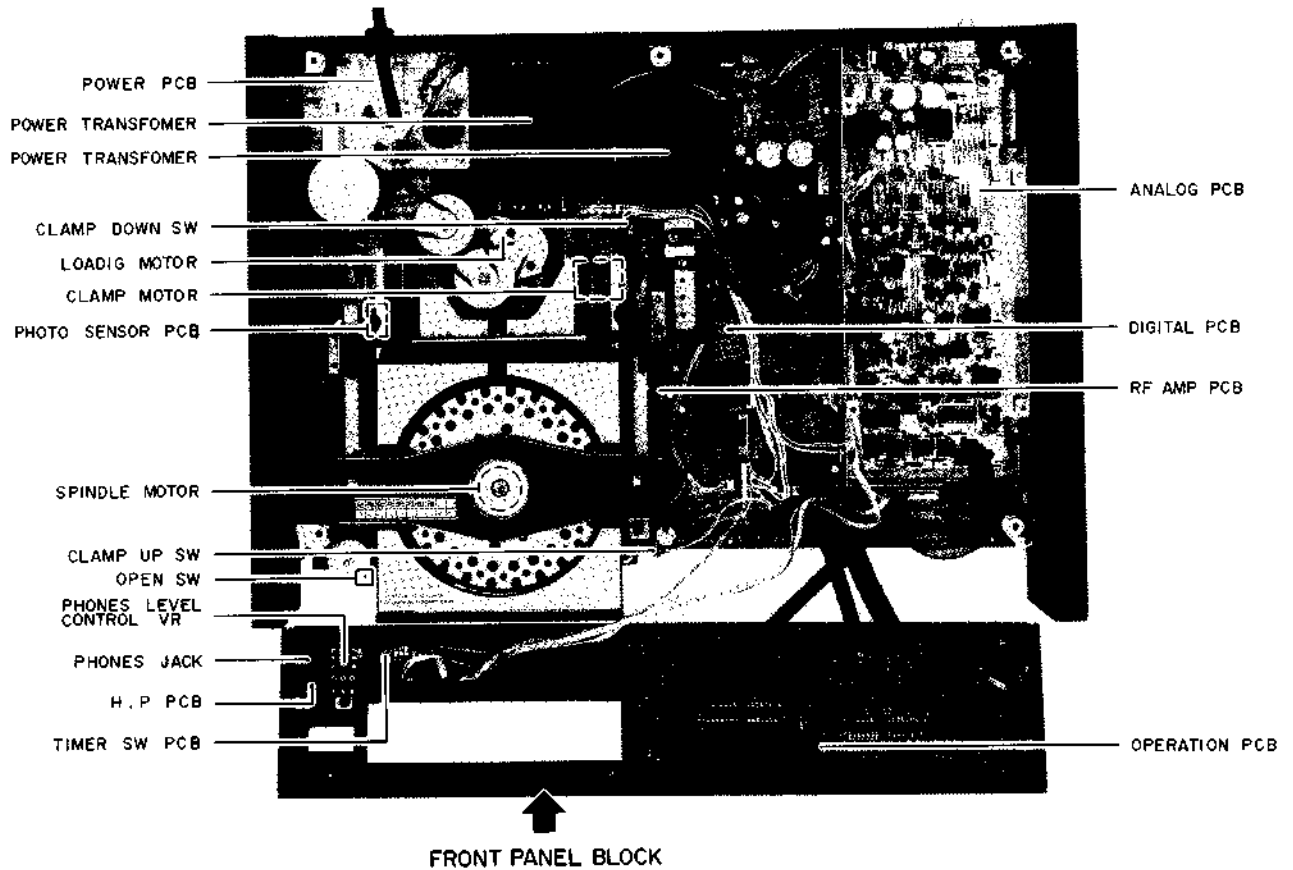

IV. REPLACEMENT OF THE PICK-UP BLOCK

PRECAUTIONS WHEN REPLACING THE PICK-UP BLOCK

- 1) The LD (Laser Diode) fixed on the pick-up block P.C. board can be damaged by static electricity or leakage from a soldering iron. Do not touch the P.C. board of the pick-up block, or use a tester to check if the electricity is on. When soldering, make sure that precautions are taken to prevent leakage from the soldering iron.
- 2) Avoid scratches, dirt or dust on the lens of the pick-up caused by touching with the fingers.
- 3) When connecting or disconnecting the RF AMP PCB (J201), make sure that the FLEXIBLE WIRING PCB is shorted circuit as shown in Fig. 4-1. Do not turn the electricity "ON" while it remains short-circuited.

- 4) For your safety from hazardous invisible Laser Radiation, replace only with pick-up block. Do not try to repair or the any adjustment.

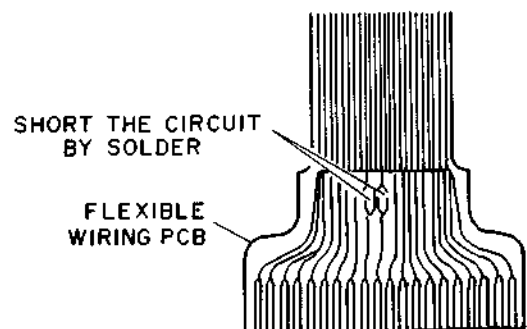

Fig. 4-1

4-1. REMOVAL OF THE DISC TRAY (Refer to Fig 4-2, and 4-3)

- 1) Remove the upper cover and the front panel and turn the power on. Depress the OPEN/CLOSE button to open the disc tray. Then turn the power OFF.
- 2) Remove E-RING A and B of the HOLDER STABILIZER BLOCK.
- 3) Remove the SCREWS C and D of the LEVER OUTSERT.
- 4) Remove the HOLDER STABILIZER BLOCK.
- 5) Remove the screws E to H and joint spring I. (Refer to Fig 4-3)

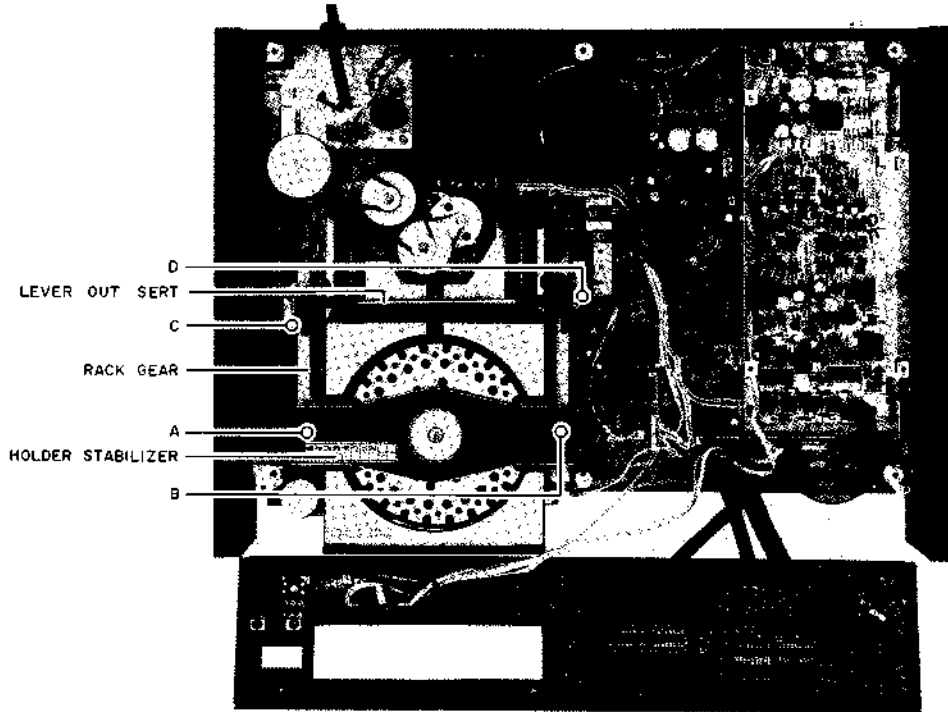

Fig. 4-2

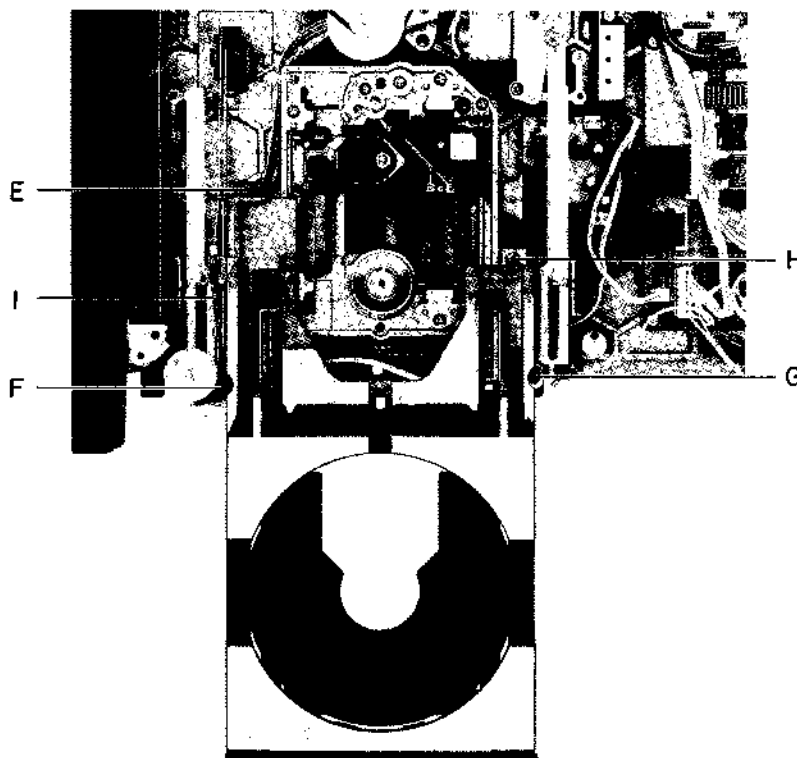

Fig. 4-3

4-2 REPLACING THE PICK-UP BLOCK (Refer to Fig 4-4)

- 1) Disconnect the connector J201 on the RF Amp PCB.
- 2) Unsolder the four terminals J and K of the coils on the PICK-UP BLOCK.
- 3) Remove the screws L to O of the GUIDE ARM and screws P, Q and R of the chassis, then remove the PICK-UP BLOCK.
- 4) Install the new PICK-UP BLOCK and assemble in reverse order.

- NOTE:**
1. After replaced PICK-UP BLOCK, DO NOT TURN THE POWER ON BEFORE RESOLDER THE SHORT CIRCUIT ON THE FLEXIBLE WIRING PCB.
 2. After replaced PICK-UP BLOCK, all the adjustments in VI. SERVO ADJUSTMENT are necessary.
 3. Semi-fixed resistor VR1 on the PICK-UP BLOCK is adjusted at the factory according to each character of the pick-up consequently "DO NOT TOUCH THIS VR1".

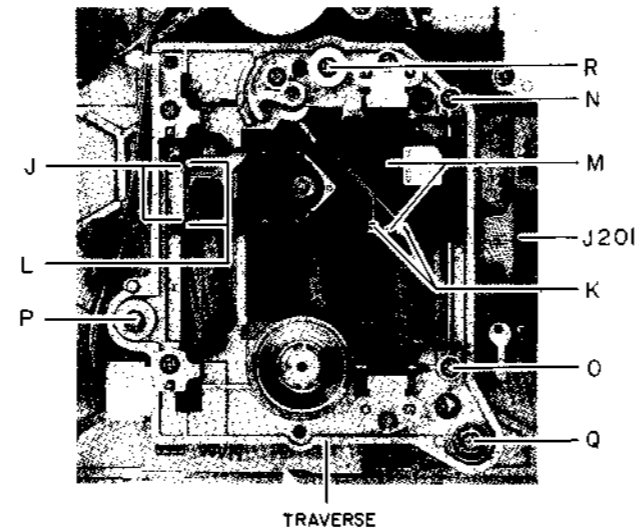

Fig. 4-4

V. REPLACEMENT OF THE SPINDLE MOTOR

- 1) Remove the SLIT WASHER and loosen the Hexagon set screw.
- 2) Pull out the TURN TABLE from the SPINDLE MOTOR.
- 3) Remove three SPINDLE MOTOR fixing screws.
- 4) Remove the connector on the SPINDLE MOTOR.
- 5) Put the new SPINDLE MOTOR on to the chassis with three screws.
- 6) Put the TURN TABLE on to the SPINDLE MOTOR shaft and adjust so that the height of the turn table from the chassis becomes 32 ± 0.1 mm as shown in Fig 5-2.

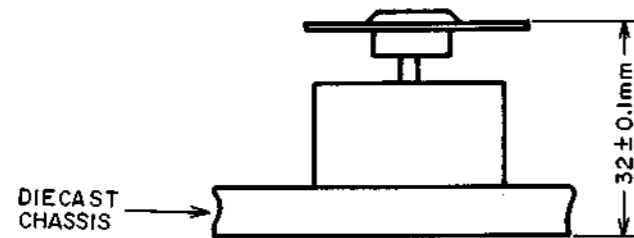

Fig. 5-2

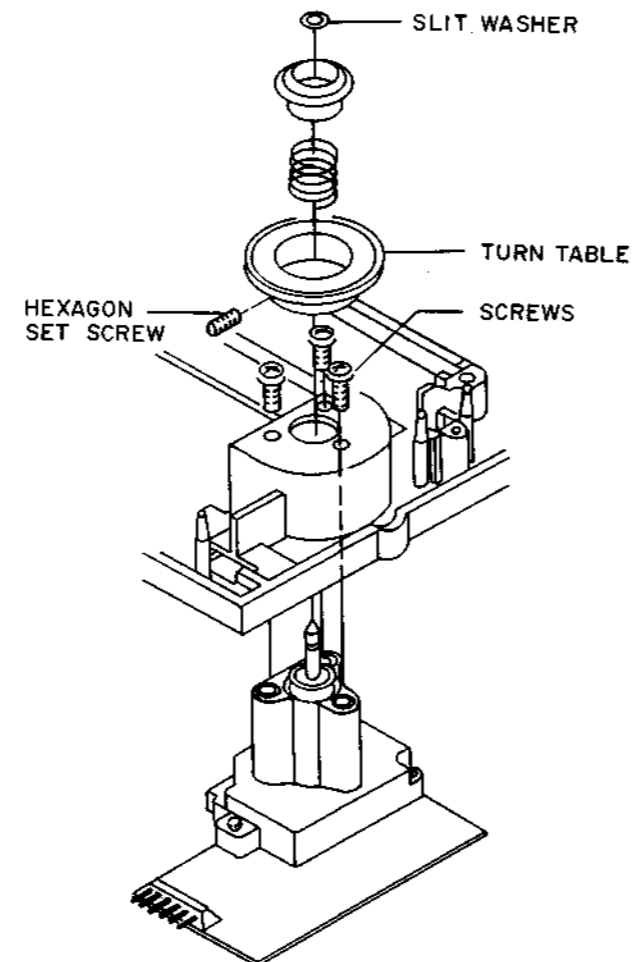

Fig. 5-1

VI. SERVO ADJUSTMENT

HOW TO USING THE TEST MODE

- While Power is on, short the pin ① and ② of the connector P3 on the DIGITAL PCB, a while, then machine set to the test mode.
- While in the test mode, following indication is indicated on the display.

90 00--93 A 00 01 B
 C 00 00 00 00 D

- A: Indicate the track number where the pick-up is locating.
 B: Indicate the test mode number.
 C: Indicate the individual time of the track.
 D: Indicate the total time.

* Indication A, C, and D are indicated only in the test mode 08, and 09.

- While in the test mode, the test mode can be advanced by pressing the **OPEN/CLOSE** button. At this time, indication B is indicated test mode number on the display.

OPERATION	INDICATION B	FUNCTION
1st push of OPEN/CLOSE Button	00 01	Pick-up lens down
2nd push of OPEN/CLOSE Button	00 02	Focus Search end
3rd push of OPEN/CLOSE Button	00 03	Focus Gain down
4th push of OPEN/CLOSE Button	00 04	CLV Kick
5th push of OPEN/CLOSE Button	00 05	CLV rough Servo "ON"
6th push of OPEN/CLOSE Button	00 06	Tracking Servo "ON"
7th push of OPEN/CLOSE Button	00 07	CLV & Sled Servo "ON"
8th push of OPEN/CLOSE Button	00 08	FOCUS & Tracking Gain normal, mute "OFF" Anti Shock "OFF", Emphasis "OFF".
9th push of OPEN/CLOSE Button	00 09	FOCUS & Tracking Gain normal, mute "OFF" Anti Shock "ON", Emphasis "OFF".
10th push of OPEN/CLOSE Button	Normal mode	Normal search

- The sled can be carrying forcedly by **FF** or **FR** button in the test modes 08 and 09.
- When push the **OPEN/CLOSE** button once from test mode 09, the machine releases from the test mode.
 * At this time, pins 1 and 2 of P3 to still shorted, the machine repeat the test mode 01 to 09 cyclically.

STEP	ADJUSTMENT ITEM	ADJ. Part	Test Point
1. Test Disc			
2. Mode			
3. Test Point & Adj. Part			
4. Result & Remarks			

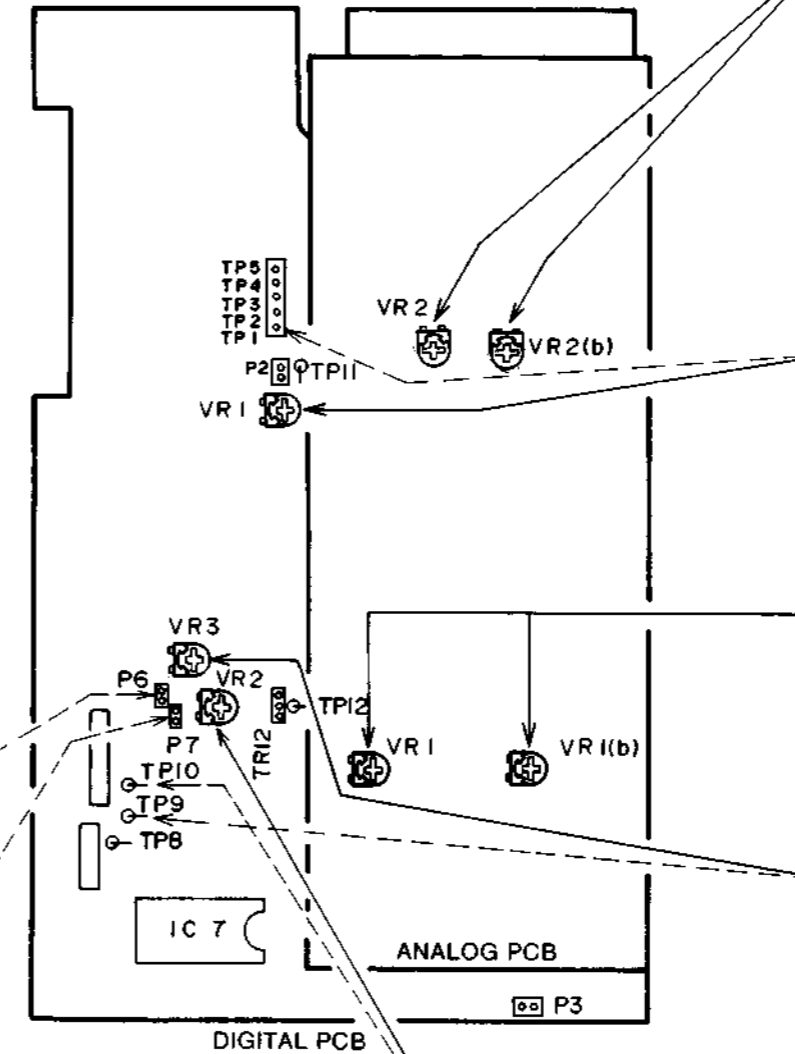

5	DC BALANCE
1.	TEST DISC TYPE III (AT-711881)
2.	PLAY
3.	• Connect a DIGITAL VOLTMETER to LINE OUT. • VR2 (L-CH) & VR2b (R-CH) on the ANALOG PCB.
4.	• Play back track No. 23 of the test disc. • 0V ± 0.1 mV

6	PLL Frequency
1.	TEST DISC TYPE III (AT-711881)
2.	PLAY
3.	• Connect a Frequency counter between TP1 and GND. • VR1
4.	Slightly turn the VR1 to clockwise so that the sound disappear, (PLL unlocked) then turn the VR1 counterclockwise and read the frequency on the frequency counter at the point sound appeared (f1), again turn the VR1 to counterclockwise so that the sound disappear then slightly turn the VR1 clockwise and read the frequency on the frequency counter at the point sound appeared (f2). Set the VR1 so that the frequency on the frequency counter is $\frac{f1 + f2}{2}$

7	Distortion Factor
1.	TEST DISC TYPE III (AT-711881)
2.	PLAY (Track No.1)
3.	• Connect the distortion meter to the LINE OUT. • VR1, VR1 (b)
4.	Minimum distortion

4	TRACKING SERVO CONTROL GAIN
1.	TEST DISC TYPE III (AT-711881)
2.	TEST MODE 8
3.	• Connect an oscilloscope between TP9 and GND. • VR3
4.	600 mV to 1Vp-p

2	E-F BALANCE
1.	TEST DISC TYPE III (AT-711881)
2.	TEST MODE 05
3.	• Connect an oscilloscope (DC Range) between P6 and GND. • VR202
4.	A = B (DC Range)

1	FOCUS SERVO OFF-SET
1.	TEST DISC TYPE III (AT-711881)
2.	TEST MODE 02
3.	• Connect a DIGITAL VOLTMETER between P7 and TP12 (GND) • VR201
4.	• Measure the voltage (A) between P7 and TP12 (GND) at the test mode 02, then turn the power is OFF and ON again. Measure the voltage (B) between P7 and TP12 (GND) and adjust VR201 so that the voltage (B) equal voltage (A).

3	FOCUS SERVO CONTROL GAIN
1.	TEST DISC TYPE III (AT-711881)
2.	TEST MODE 08
3.	• Connect an oscilloscope between TP10 and GND. • VR2
4.	1.0 to 1.4 Vp-p

VII. PARTS LIST

ATTENTION

1. When placing an order for parts, be sure to list Part No., Model No. and the description of each part. Otherwise, the non-delivery of the part or the delivery of a wrong part may result.
2. Please make sure that Part No. is correct when ordering.
If not, a part different from the one you ordered may be delivered.
3. Since the parts shown in Parts List of Preliminary Service Manual may have been the subject of changes, please use this Parts List for all future reference.

HOW TO USE THIS PARTS LIST

1. This Parts List lists those parts which are considered necessary for repairs. Other common parts, such as resistors and capacitors, are listed in the "Common List for Service Parts" from which these parts should be selected and stocked.
2. The Recommended Spare Parts List shows those parts in the Parts List which are considered particularly important for service.
3. Parts not shown in the Parts List and "Common List for Service Parts" will not in principle be supplied.
4. How to read the Parts List.

a) Mechanism Block

b) PC Board

2. HEAD BASE BLOCK

REF. NO.	PART NO.	DESCRIPTION
2-1x	BH-T2023A320A	HEAD BASE BLOCK
2-2	HP-H2206A010A	HEAD R/P PR4-8FU C
2-3	ZS-477876	PAN20x03STL CMT
2-4	ZS-536488	BID20x08STL CMT
2-5	ZG-402895	SP CS ANGLE ADJUST

SP (Service Parts) Classification

A small "x" indicates that this part is not shown in the Photo or Illustration.

This number corresponds with the individual parts index number in that figure.

This number corresponds with the Figure Number.

6. MAIN PC BOARD

REF. NO.	PART NO.	DESCRIPTION
6-IC1	EI-324536	IC HD14049BP
6-IC2	EI-336801	IC MB8841-564M
6-C1A	EC-338399	C MMY V 223M 250AC [U,E,B,S]
6-C1B	EC-350949	C MMY V 223M 250DC [J]
6-C1C	EC-338397	C MMY V 223M 125AC [C,A]
6-X1	EI-318384	OSC X'TAL NC-18C

Symbols for primary destination

[A]: AAL(U.S.A.) [S]: SAA(Australia)
 [B]: BEAB(England) [U]: U/T(Universal Area)
 [C]: CSA(Canada) [V]: VDE(W. Germany)
 [E]: CEE(Europe) [Y]: Custom Version
 [J]: JPN(Japan)

SP (Service Parts) Classification

These reference symbols correspond with component symbols in the Schematic Diagrams.

The available PC Board Blocks are listed separately.

5. When Part No. is known, Parts Index at end of Parts List can be used to locate where that part is shown in Parts List by its Reference No. listed at right of Part No.

WARNING

△ (*) INDICATES SAFETY CRITICAL COMPONENTS. FOR CONTINUED SAFETY, REPLACE SAFETY CRITICAL COMPONENTS ONLY WITH MANUFACTURE'S RECOMMENDED PARTS.

AVERTISSEMENT

△ (*) IL INDIQUE LES COMPOSANTS CRITIQUES DE SÉCURITÉ. POUR MAINTENIR LE DEGRÉ DE SÉCURITÉ DE L'APPAREIL, NE REMPLACER QUE DES PIÈCES RECOMMANDÉES PAR LE FABRICANT.

1. RECOMMENDED SPARE PARTS

Ref. No.	Part No.	Description
1	BM-377823	MOTOR BHR-2600C
2	BM-328441	MOTOR RF-510T(12620) [M903][LOADING MOTOR]
3	BO-377825	PICK UP KSS-151A
4	*BT-377813	TRANS POW P2026A(B,S) [B]
5	*BT-377811	TRANS POW P2026A(C,A) [C,A]
6	*BT-377812	TRANS POW P2026A(E,V) [E,V]
7	*BT-377809	TRANS POW P2026A(U) [U]
8	*BT-377808	TRANS POW P2026B(B,S) [B]
9	*BT-377805	TRANS POW P2026B(C,A) [C,A]
10	*BT-377806	TRANS POW P2026B(E,V) [E,V]
11	*BT-377803	TRANS POW P2026B(U) [U]
12	BT-368261	TRANS PULSE TC-1027-04
13	ED-377845	D LED BG5505S CLEAR
14	ED-356424	D LED BG5525S GREEN
15	ED-337413	D LED SLP-135B RED
16	ED-360409	D PHOTO PN323B
17	ED-301911	D SILICON H DS448
18	ED-344280	D SILICON H GMA-01-FY2 F05
19	*ED-379184	D SILICON HRP22 F10 50/1.0A
20	*ED-330622	D SILICON 1SR35-100VL 100/1.0A
21	ED-367576	D ZENER H HZS5.6J B2 F05
22	ED-346552	D ZENER H HZ11L C1
23	ED-346558	D ZENER H HZ12L B1
24	ED-346568	D ZENER H HZ16L 3
25	ED-346591	D ZENER H HZ36L 3
26	ED-330962	D ZENER H HZ4 C1
27	ED-338333	D ZENER H HZ5 B2
28	ED-343410	D ZENER H HZ6L A1
29	ED-346526	D ZENER H HZ6L B1
30	ED-346545	D ZENER H HZ9L C2
31	ED-377861	DETECTOR 6N137 (YHP)
32	*EF-355226	FUSE BET T 250V 1.00A [B]
33	*EF-358641	FUSE BET T 250V 800MA [B]
34	*EF-623103	FUSE SEMKO T 250V 1.00A [E,V]
35	*EF-258344	FUSE SEMKO T 250V 800MA [E,V]
36	*EF-309392	FUSE TSC 125V 1.25A [C,A]
37	*EF-308847	FUSE TSC 125V 1.60A [C,A]
38	EH-380185J	FILTER EMI ZBF503S-01
39	EI-377857	IC BA6247N
40	EI-368608	IC CXA1081
41	EI-368609	IC CXA1082A
42	EI-368610	IC CXD1135Q
43	EI-362975	IC HD6805S1PB18
44	EI-336794	IC LB1240
45	EI-368611	IC LC3617AS-15
46	EI-377767	IC LC6568H-3425 P2026 COSTOM
47	*EI-377860	IC M5F7805
48	EI-380319J	IC M50747-433SP AKAI-3 CUSTOM
49	EI-349719	IC M5218P
50	EI-362588	IC M5238P
51	EI-355115	IC M5240P
52	EI-377191	IC NJM5532D-D
53	EI-368612	IC PCM56P
54	EI-360040	IC TC74HC04P
55	EI-360039	IC TC74HC08P
56	EI-367271	IC UPC1490HA
57	*EI-377246	IC UPC79M05HF
58	EI-377855	IC YM3404B
59	EI-349372	OSC CE CSA4.00MG 4MHZ

Ref. No.	Part No.	Description
60	EI-374176	OSC X'TAL AT-51 16.9344MHZ
61	EM-377851	IND FL 14-BT-14GK CHARACTER
62	EQ-348929	RELAY SIG G5A-237P 2TR 12V
63	ES-344253	SW LEAF MSW-1418J 01-1 NO [OPEN SW]
64	ES-344257	SW LEAF MSW-1418L 01-1 NO [CLAMP DOWN SW]
65	*ES-377828J	SW PUSH ESB8296V 01-1 [POWER]
66	ES-377848	SW SLIDE SSSU01002A [TIMER SW]
67	ES-377867	SW SLIDE SSSU12002A [DIGITAL OUT ON/OFF]
68	*ES-349464	SW SLIDE 00120319 01-2 [U]
69	ES-349474	SW TACT SKHHAM004A
70	ET-379553J	DETECTOR PC827
71	ET-371075	TR DTA124XS
72	ET-370634	TR DTA143XS
73	ET-373485	TR DTC123JS
74	ET-337891	TR PHOTO PH101
75	ET-338244	TR 2SA1207 R,S
76	ET-348829	TR 2SA1209 S,T
77	ET-353899	TR 2SA1317 S,T,U
78	ET-349718	TR 2SA1392 S,T
79	ET-352726	TR 2SA1392 T,U
80	*ET-318237	TR 2SB764 E,F
81	ET-356817	TR 2SB891 Q,R
82	ET-348830	TR 2SC2909 S,T
83	ET-348831	TR 2SC2911 S,T
84	ET-360067	TR 2SC3330 T,U F05
85	ET-349081	TR 2SC3383 S,T
86	ET-354083	TR 2SD1189 Q,R
87	ET-365456	TR 2SD1468S Q,R,S
88	ET-370809	TR 2SD1468S R,S
89	*ET-310148	TR 2SD612K E,F
90	EV-378744J	VR ROTARY RK16312A0 B104X2 [HEADPHONE LEVEL]
91	MB-377660	BELT(A)
92	MB-377661	BELT(B)
93	MB-377790	BELT(C)
94	MZ-352143	GEAR WORM
95	MZ-377667	GEAR WORM WHEEL

2. MECHA BLOCK

Ref. No.	Part No.	Description
1	ZW-270101	RING E 300SUP CMT
2	ZS-355149	PT BID26X05STL CMT
3	MZ-377671	PLATE MAGNET
4	MZ-377826	MAGNET FM 30X17X5.2
5	SC-B377673	HOLDER STABILIZER PART
7	SC-P2026A060A	COVER DISC TRAY BLK CD-93
8	SC-377675	DISK TRAY CD-93
9	SZ-377682	SHUTTER
10	ZS-377929	BID30X03STL BNI
11	SP-377742	PANEL TRAY B
12	ZS-380701J	ST BID30X10STL M3 EARTH LOCK
13	ML-377647A	LEVER ELEVATION(L)
14	ML-380551J1	LEVER ELEVATION(R)
15	ZG-358111	SP T5-03.2/0.29-22.4 T5-065
16	SZ-377677	HOLDER DISK
17	ZS-355511	BID30X06STL BNI
18	MS-377649A	SHAFT TRAY(L)
19	MS-380550J1	SHAFT TRAY(R)
20	ML-377652	HOLDER SHAFT(L)
21	ML-377653	HOLDER SHAFT(R)
22	MB-378682J	CUSHION TRAY PART
23	ZW-376391	PW61X100X013PSL

MECHA BLOCK

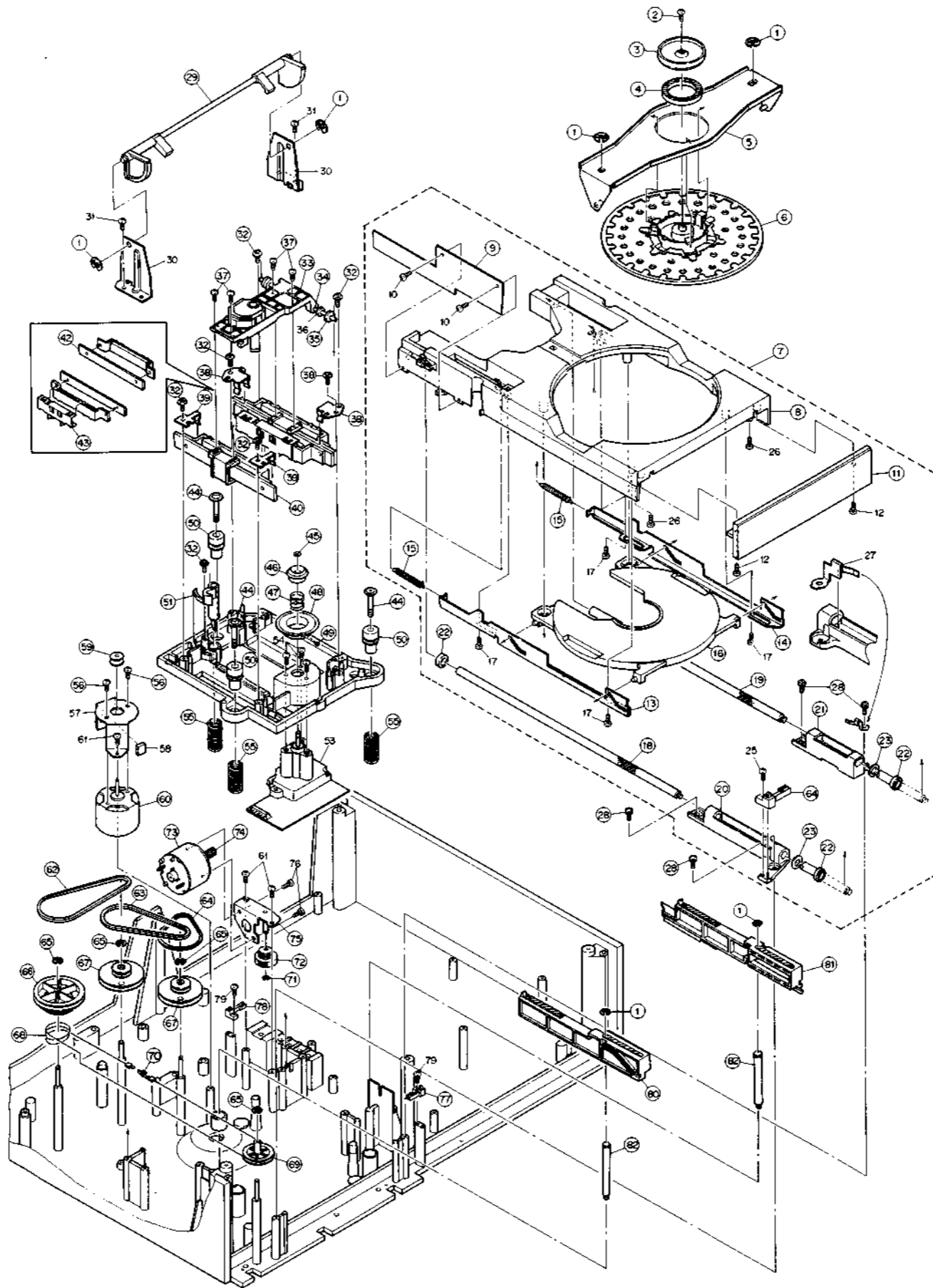

Ref. No.	Part No.	Description
24	ES-344253	SW LEAF MSW-1418J 01-1 NO [OPEN SW]
25	ZS-377928	PT BID20X08STL CMT
26	ZS-378743J	PAN30X06STL NI3 C080
27	ZG-379839J	SP PLATE SHAFT
28	ZS-378741J	PAN30X06STL NI3 PW080
29	ML-377668	LEVER OUTSERT
31	ZS-376365	BID30X06STL COP
32	ZS-377926	ST BR30X05STL BM C080
33	BO-377825	PICK UP KSS-151A
34	MS-375730	SHAFT P.U
35	MB-375732	CUSHION P.U
36	ZW-378397	PW30X080X013PSL
37	ZS-378680J	BT PAN17X04STL CMT
38	MZ-375728	HOLDER YOKE F
39	MZ-375729	HOLDER YOKE V
40	EO-B375725	COIL V PART
41	EO-B375723	COIL F PART
42	BV-B375720	MAGNET PART
44	ZS-377679	SCREW GRADUATED(B)
45	ZW-377824	SLIT W26X060X025LMN
46	MZ-377646	GUIDE DESK
47	ZG-381312J	SP PUSH T.T(2)
48	MZ-377645	TURN TABLE
49	ZS-378683J	6SET26X030SCM PKR WP
50	MB-375733	CUSHION RUBBER
53	BM-377823	MOTOR BHR-2600C
54	ZS-590128	BID26X06STL BNI
55	ZG-375734	SP PUSH CUSHION
56	ZS-377930	BID26X03STL BNI
59	MR-345182	PULLEY MOTOR
60	BM-328441	MOTOR RF-510T(12620) [M903][LOADING MOTOR]
61	ZS-376365	BID30X06STL COP
62	MB-377660	BELT(A)
63	MB-377661	BELT(B)
64	MB-377790	BELT(C)
65	ZW-270088	RING E190SUP CMT
66	MR-377657	PULLEY ROPE MAIN
67	BR-377659	PULLEY BELT
68	SZ-377791	JAINT WIRE
69	MR-377658	PULLEY ROPE SUB
70	ZG-377680	SP PULL ROPE
71	ZW-270101	RING E 300SUP CMT
72	MZ-377667	GEAR WORM WHEEL
73	BM-328441	MOTOR RF-510T(12620) [M904][CLAMP MOTOR]
74	MZ-352143	GEAR WORM
76	ZS-377930	BID26X03STL BNI
77	ES-344257	SW LEAF MSW-1418L 01-1 NO [CLAMP DOWN SW]
78	ES-344257	SW LEAF MSW-1418L 01-1 NO [CLAMP UP SW]
79	ZS-376576	BID20X06STL BNI
80	SC-377654	RACK GEAR(L)
81	SC-377655	RACK GEAR(R)
82	MZ-377656	PROP 9 M.SCREW RACK GEAR
83	ZG-381284J	SP PUSH CUSHION(2)
84	MV-368886	BALL 300STL
85	ZG-351817	SP PLATE THRUST
86	ZS-345319	ST BR26X05STL CMT

3. P.C BOARD BLOCK

Ref. No.	Part No.	Description
1A	BA-P2026A120A	PC(##) DIGITAL BLK CD-93(U) [U]
1B	BA-P2026A120B	PC(##) DIGITAL BLK CD-93(E) [E,V,B]
1C	BA-P2026A120E	PC(##) DIGITAL BLK CD-93(C) [C,A]
2A	BA-P2026A130A	PC ANALOG BLK CD-93(U) [U]
2B	BA-P2026A130B	PC ANALOG BLK CD-93(E) [C,A,E,V,B]
3	BA-P2026A150A	PC(##) OPERATION BLK CD-93

4. DIGITAL P.C BOARD

Ref. No.	Part No.	Description
D1	ED-346545	D ZENER H HZ9L C2
D2	*ED-379184	D SILICON HRP22 F10 50/1.0A
D3	ED-301911	D SILICON H DS448
D4	ED-344280	D SILICON H GMA-01-FY2 F05
D5	ED-344280	D SILICON H GMA-01-FY2 F05
D6	ED-330962	D ZENER H HZ4 C1
D7	ED-330962	D ZENER H HZ4 C1
D8	ED-301911	D SILICON H DS448
D9	ED-346591	D ZENER H HZ36L 3
D10	*ED-330622	D SILICON 1SR35-100VL 100/1.0A
D11	*ED-330622	D SILICON 1SR35-100VL 100/1.0A
D12	*ED-330622	D SILICON 1SR35-100VL 100/1.0A
D13	*ED-330622	D SILICON 1SR35-100VL 100/1.0A
D14	ED-344280	D SILICON H GMA-01-FY2 F05
D15	ED-344280	D SILICON H GMA-01-FY2 F05
D16	ED-367576	D ZENER H HZ5.6J B2 F05
D17	*ED-330622	D SILICON 1SR35-100VL 100/1.0A
D18	*ED-330622	D SILICON 1SR35-100VL 100/1.0A
D19	ED-338333	D ZENER H HZ5 B2
D20	ED-301911	D SILICON H DS448
D23	*ED-379184	D SILICON HRP22 F10 50/1.0A
D24	*ED-379184	D SILICON HRP22 F10 50/1.0A
D25	*ED-379184	D SILICON HRP22 F10 50/1.0A
FL901	EH-380185J	FILTER EMI ZBF503S-01
IB1	EH-352061	COMP R RKC1/888D 104J
IB2	EH-378669J	COMP R RKC5DS 104J
IB3	EH-364919	COMP R RKC8BS 473J
IB4	ER-371844	COMP R RKC3BS 472J
IB5	EH-348116	COMP R RKC1/8B3 473J
IB6	EH-348116	COMP R RKC1/8B3 473J
IC1	EI-368610	IC CXD1135Q
IC2	EI-368611	IC LC3517AS-15
IC3	EI-377855	IC YM3404B
IC4	EI-360040	IC TC74HC04P
IC5	EI-360039	IC TC74HC08P
IC6	EI-362975	IC HD6805S1PB18
IC7	EI-380319J	IC M50747-433SP AKAI-3 CUSTOM
IC8	EI-377857	IC BA6247N
IC9	EI-368609	IC CXA1082A
IC10	EI-349719	IC M5218P
IC11	EI-349719	IC M5218P
IC12	*EI-377860	IC M5F7805
IC13	*EI-377246	IC UPC79M05HF
J11	EJ-377834	PIN J P2026 ORANGE 1P [DIGITAL OUT]
L1	EO-345913	COIL FIX 1 LAL03KH 100K
P1	EJ-374191	SOCKET OPTICAL TOTX172 [OPTICAL OUT]
PT1	BT-368261	TRANS PULSE TC-1027-04
R71	*ER-322332	R CB H S10 FS RDS 1/4W 8R2J
SW1	ES-377867	SW SLIDE SSSU12002A [DIGITAL OUT ON/OFF]
TR1	ET-360067	TR 25C3330 T,U F05

Ref. No.	Part No.	Description
TR2	ET-365456	TR 25D1468S Q,R,S
TR3	ET-360067	TR 25C3330 T,U F05
TR4	ET-360067	TR 25C3330 T,U F05
TR5	ET-360067	TR 25C3330 T,U F05
TR6	ET-354083	TR 25D1189 Q,R
TR7	ET-356817	TR 25B891 Q,R
TR8	ET-354083	TR 25D1189 Q,R
TR9	ET-356817	TR 25B891 Q,R
TR10	ET-360067	TR 25C3330 T,U F05
TR11	ET-352726	TR 25A1392 T,U
TR12	ET-360067	TR 25C3330 T,U F05
TR14	ET-356817	TR 25B891 Q,R
TR17	ET-360067	TR 25C3330 T,U F05
TR18	ET-353899	TR 25A1317 S,T,U
TR19	*ET-349081	TR 25C3383 S,T
TR20	*ET-318237	TR 25B764 E,F
TR21	ET-360067	TR 25C3330 T,U F05
VR1	EV-380682J	R S-FIX H KVSF687A 0.30W 15Z
VR2	EV-358829	R S-FIX H RH0615C 0.10W 223
VR3	EV-358829	R S-FIX H RH0615C 0.10W 223
X1	EI-374176	OSC X'TAL AT-51 16.9344MHZ
X2	EI-349372	OSC CE CSA4.00MG 4MHZ
F1A	*EF-309392	FUSE TSC 125V 1.25A [C,A]
F2A	*EF-308847	FUSE TSC 125V 1.60A [C,A]
F1B	*EF-258344	FUSE SEMKO T 250V 800MA [E,V]
F2B	*EF-258344	FUSE SEMKO T 250V 800MA [E,V]
F1C	*EF-358641	FUSE BET T 250V 800MA [B]
F2C	*EF-358641	FUSE BET T 250V 800MA [B]

5. RF AMP P.C BOARD

Ref. No.	Part No.	Description
IC201	EI-368608	IC CXA1081
TR201	ET-349718	TR 25A1392 S,T
VR201	EV-356577	R S-FIX H RH0615C 0.10W 103
VR202	EV-358829	R S-FIX H RH0615C 0.10W 223

6. ANALOG P.C BOARD

Ref. No.	Part No.	Description
D1	ED-377845	D LED BG5505S CLEAR
D2	ED-377845	D LED BG5505S CLEAR
D3	ED-377845	D LED BG5505S CLEAR
D4	ED-377845	D LED BG5505S CLEAR
D5	ED-301911	D SILICON H DS448
D6	ED-301911	D SILICON H DS448
D7	ED-301911	D SILICON H DS448
D8	ED-343410	D ZENER H HZ6L A1
D9	ED-301911	D SILICON H DS448
D10	*ED-330622	D SILICON 1SR35-100VL 100/1.0A
D11	*ED-330622	D SILICON 1SR35-100VL 100/1.0A
D12	*ED-379184	D SILICON HRP22 F10 50/1.0A
D13	*ED-379184	D SILICON HRP22 F10 50/1.0A
D14	*ED-379184	D SILICON HRP22 F10 50/1.0A
D15	*ED-379184	D SILICON HRP22 F10 50/1.0A
D16	ED-346558	D ZENER H HZ12L B1
D17	ED-301911	D SILICON H DS448
D18	ED-346552	D ZENER H HZ11L C1

Ref. No.	Part No.	Description
D19	ED-346552	D ZENER H HZ11L C1
D20	ED-346552	D ZENER H HZ11L C1
D21	ED-346552	D ZENER H HZ11L C1
D22	ED-356424	D LED BG5525S GREEN
D23	ED-356424	D LED BG5525S GREEN
D24	ED-346568	D ZENER H HZ16L 3
D25	ED-346568	D ZENER H HZ16L 3
D26	ED-356424	D LED BG5525S GREEN
D27	ED-356424	D LED BG5525S GREEN
D28	ED-379184	D SILICON HRP22 F10 50/1.0A
D33	ED-379184	D SILICON HRP22 F10 50/1.0A
D34	ED-379184	D SILICON HRP22 F10 50/1.0A
D35	ED-346526	D ZENER H HZ6L B1
D36	ED-346526	D ZENER H HZ6L B1
FL1	EH-380185J	FILTER EMI ZBF503S-01
FL2	EH-380185J	FILTER EMI ZBF503S-01
FL3	EH-380185J	FILTER EMI ZBF503S-01
IC1	ED-377861	DETECTOR 6N137 (YHP)
IC2	ED-377861	DETECTOR 6N137 (YHP)
IC3	ED-377861	DETECTOR 6N137 (YHP)
IC4	EI-368612	IC PCM56P
IC5	EI-355115	IC M5240P
IC6	EI-377191	IC NUM5532D-D
IC8	EI-362588	IC M5238P
IC9	ET-379553J	DETECTOR PC827
J2	EJ-377869	PIN J YKC21-0299 GP 2P [LINE OUT]

Ref. No.	Part No.	Description
RL1	EQ-348929	RELAY SIG G5A-237P 2TR 12V
RL2	EQ-348929	RELAY SIG G5A-237P 2TR 12V
R59	ER-378672J	R OMF H S10 FS 1/2W 181J
R60	ER-378672J	R OMF H S10 FS 1/2W 181J
TR1	ET-352726	TR 25A1392 T,U
TR2	ET-338244	TR 25A1207 R,S
TR3	ET-348830	TR 25C2909 S,T
TR4	ET-349081	TR 25C3383 S,T
TR5	ET-348831	TR 25C2911 S,T
TR6	ET-348829	TR 25A1209 S,T
TR7	ET-352726	TR 25A1392 T,U
TR8	ET-338244	TR 25A1207 R,S
TR9	ET-348830	TR 25C2909 S,T
TR10	ET-349081	TR 25C3383 S,T
TR11	ET-348831	TR 25C2911 S,T
TR12	ET-348829	TR 25A1209 S,T
TR13	ET-371075	TR DTA124XS
TR14	ET-373485	TR DTC123JS
TR15	ET-370634	TR DTA143XS
TR16	*ET-349081	TR 25C3383 S,T
TR17	ET-352726	TR 25A1392 T,U
TR18	*ET-348831	TR 25C2911 S,T
TR19	*ET-348829	TR 25A1209 S,T
TR20	ET-352726	TR 25A1392 T,U
TR21	ET-349081	TR 25C3383 S,T
TR22	*ET-348831	TR 25C2911 S,T
TR23	*ET-348829	TR 25A1209 S,T
TR24	ET-352726	TR 25A1392 T,U
TR25	ET-349081	TR 25C3383 S,T
TR30	*ET-310148	TR 25D612K E,F
TR31	*ET-352726	TR 25A1392 T,U
VR1	EV-357619	R S-FIX H RH0615C 0.10W 104
VR2	EV-356582	R S-FIX H RH0615C 0.10W 473
F3A	*EF-308847	FUSE TSC 125V 1.60A [C,A]
F4A	*EF-308847	FUSE TSC 125V 1.60A [C,A]
F3B	*EF-623103	FUSE SEMKO T 250V 1.00A [E,V]
F4B	*EF-623103	FUSE SEMKO T 250V 1.00A [E,V]
F3C	*EF-355226	FUSE BET T 250V 1.00A [B]
F4C	*EF-355226	FUSE BET T 250V 1.00A [B]

7. OPERATION P.C BOARD

Ref. No.	Part No.	Description
IC1	EI-377767	IC LC8568H-3425 P2026 COSTOM
IC2	EI-336794	IC LB1240
IC3	EI-336794	IC LB1240
IC4	EI-336794	IC LB1240
IC5	EI-336794	IC LB1240
IN1	EM-377851	IND FL 14-BT-14GK CHARACTER
TS1	ES-349474	SW TACT SKHHAM004A
TS2	ES-349474	SW TACT SKHHAM004A
TS3	ES-349474	SW TACT SKHHAM004A
TS4	ES-349474	SW TACT SKHHAM004A
TS5	ES-349474	SW TACT SKHHAM004A
TS6	ES-349474	SW TACT SKHHAM004A
TS7	ES-349474	SW TACT SKHHAM004A
TS8	ES-349474	SW TACT SKHHAM004A
TS9	ES-349474	SW TACT SKHHAM004A
TS10	ES-349474	SW TACT SKHHAM004A
TS11	ES-349474	SW TACT SKHHAM004A
TS12	ES-349474	SW TACT SKHHAM004A
TS13	ES-349474	SW TACT SKHHAM004A
TS14	ES-349474	SW TACT SKHHAM004A
TS15	ES-349474	SW TACT SKHHAM004A
TS16	ES-349474	SW TACT SKHHAM004A
TS17	ES-349474	SW TACT SKHHAM004A
TS18	ES-349474	SW TACT SKHHAM004A
TS19	ES-349474	SW TACT SKHHAM004A
TS20	ES-349474	SW TACT SKHHAM004A
TS21	ES-349474	SW TACT SKHHAM004A
TS22	ES-349474	SW TACT SKHHAM004A
TS23	ES-349474	SW TACT SKHHAM004A
TS24	ES-349474	SW TACT SKHHAM004A
TS25	ES-349474	SW TACT SKHHAM004A
TS26	ES-349474	SW TACT SKHHAM004A
TS27	ES-349474	SW TACT SKHHAM004A
TS28	ES-349474	SW TACT SKHHAM004A
TS29	ES-349474	SW TACT SKHHAM004A
TS30	ES-349474	SW TACT SKHHAM004A
TS31	ES-349474	SW TACT SKHHAM004A

8. SENSOR C P.C BOARD

Ref. No.	Part No.	Description
D1	ED-360409	D PHOTO PN323B
IC1	EI-367271	IC UPC1490HA

9. HEADPHONE P.C BOARD

Ref. No.	Part No.	Description
FL101	EH-380185J	FILTER EMI ZBF503S-01
IC101	EI-362588	IC M5238P
J101	EJ-380560J	PHONE J 3P LG1212-0103 GP 6.3 [HEADPHONE]
TR101	ET-370809	TR 2SD1468S R,S
VR101	EV-378744J	VR ROTARY RK16312A0 B104X2 [HEADPHONE LEVEL]

10. TIMER SW P.C BOARD

Ref. No.	Part No.	Description
SW101	ES-377848	SW SLIDE SSSU01002A [TIMER SW]

11. POWER SUPPLY P.C BOARD

Ref. No.	Part No.	Description
C1A	*EC-320548	C CE V F 103Z 250AC [U]
C1B	*EC-338411	C CE V FZ 103P 400AC [C.A]
C1C	*EC-367928	C MMY V XE 103M 250AC [E.V.B]
C2A	*EC-320548	C CE V F 103Z 250AC [U]
C2B	*EC-338411	C CE V FZ 103P 400AC [C.A.E.V.B]
C3A	*EC-320548	C CE V F 103Z 250AC [U]
C3B	*EC-338411	C CE V FZ 103P 400AC [C.A.E.V.B]
L1	*EO-338409	COIL LF FK0B160MH02 250UH
SW1	*ES-377828J	SW PUSH ESB8296V 01-1 [POWER]
VS1	*ES-349464	SW SLIDE 00120319 01-2 [U]

12. LED P.C BOARD

Ref. No.	Part No.	Description
D301	ED-337413	D LED SLP-1358 RED

13. PHOTO SENSOR P.C BOARD

Ref. No.	Part No.	Description
PH401	ET-337891	TR PHOTO PH101
PH402	ET-337891	TR PHOTO PH101

14. TR P.C BOARD

Ref. No.	Part No.	Description
TR613	ET-354083	TR 2SD1189 Q,R

ASSEMBLY BLOCK

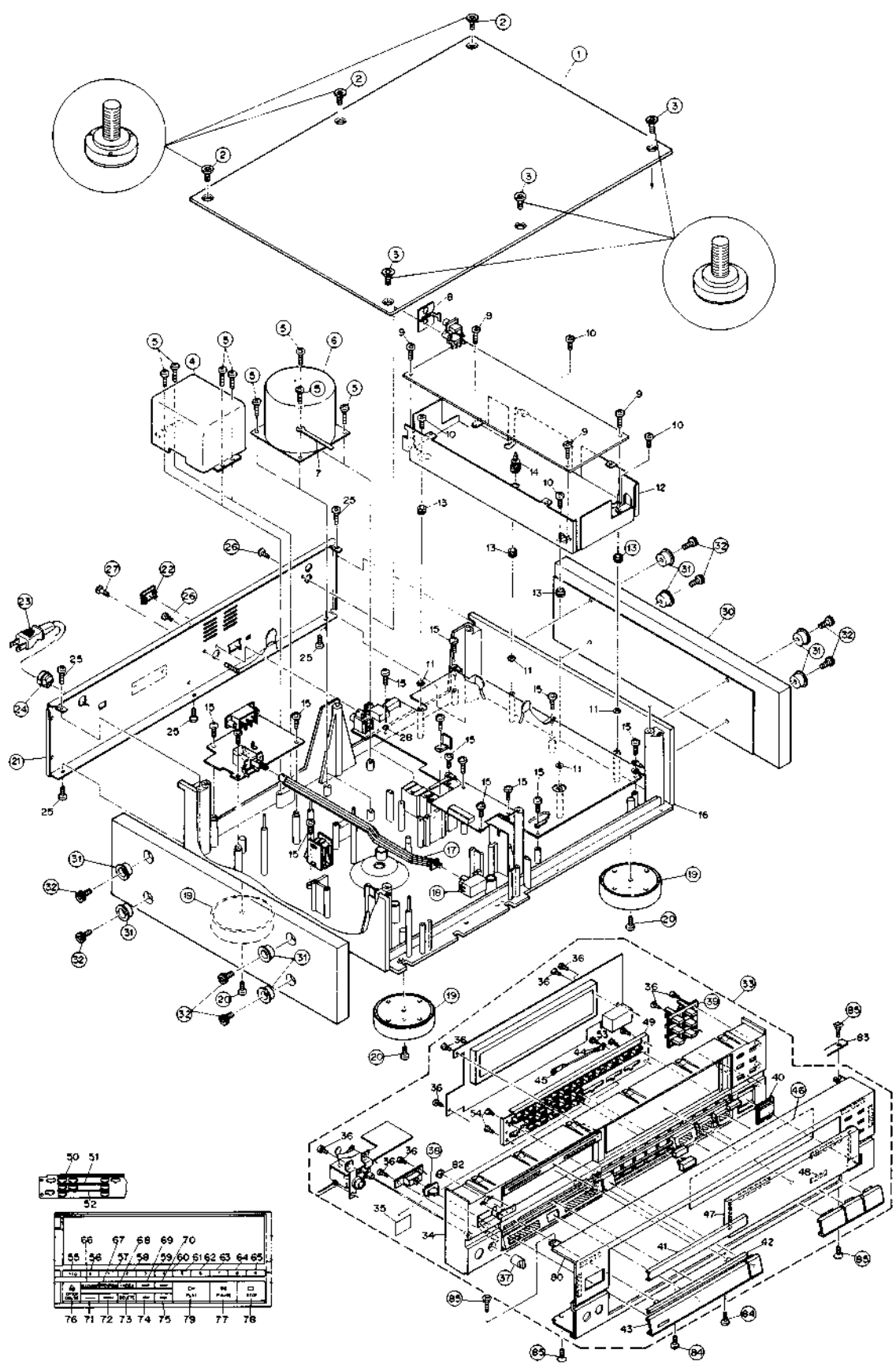

PARTS LIST

15. ASSEMBLY BLOCK

Ref. No.	Part No.	Description
1	SP-377745	COVER TOP B
2	ZS-378733J	SCREW TOP COVER B
3	ZS-377746	SCREW TOP COVER PROJECTION B
4A	*BT-377803	TRANS POW P2026B(U) [U]
4B	*BT-377805	TRANS POW P2026B(C,A) [C,A]
4C	*BT-377806	TRANS POW P2026B(E,V) [E,V]
4D	*BT-377808	TRANS POW P2026B(B,S) [B]
5	ZS-416687	BID40X08STL CMT
6A	*BT-377809	TRANS POW P2026A(U) [U]
6B	*BT-377811	TRANS POW P2026A(C,A) [C,A]
6C	*BT-377812	TRANS POW P2026A(E,V) [E,V]
6D	*BT-377813	TRANS POW P2026A(B,S) [B]
9	ZS-377153	ST BID30X06STL COP
10	ZS-377688	SCREW SHIELD
11	ZW-378813J	PW51X100X050PBR W/WF TAPE
15	ZS-376365	BID30X06STL COP
17	ML-377689	JOINT SW
18	SK-373236B	KNOB POWER-B
19	SA-8377816	FOOT PART
20	ZS-552824	BID40X18STL BNI
21A	SP-380716J2	PANEL REAR CD-93(U) [U]
21B	SP-380718J2	PANEL REAR CD-93(C,A) [C,A]
21C	SP-380719J2	PANEL REAR CD-93(E) [E]
21D	SP-380720J2	PANEL REAR CD-93(V) [V]
21E	SP-380721J2	PANEL REAR CD-93(B,S) [B]
22	SE-375348	ESCUICHEON
23A	*EW-363659	AC CORD 200 0129AVFF B070 A U [U]
23B	*EW-363634	AC CORD200 0238ASPT2 B070 A UC [C,A]
23C	*EW-363672	AC CORD 200 0364 LCFL B070 A EV [E,V]
23D	*EW-363684	AC CORD 200 LCFL B070 A B [B]
25	ZS-376523	ST BID30X06STL BNI EARTH LOCK
26	ZS-350934	PT BR30X08STL BNI
27	ZS-332468	T2BR30X20STL NI3 GUIDE
28	ZW-259503	PW31X080X050NYL
29	SP-377747	SIDE BOARD(L)
30	SP-377748	SIDE BOARD(R)
31	ZW-376292	WASHER SIDE BOARD
32	ZS-380284J	SCREW SIDE BOARD(2)
33	BD-P2026A140A	PANEL FRONT BLK CD-93-B
36	ZS-332009	PT BR30X06STL CMT
37	SK-377733	KNOB VOL B
38	SK-377734	KNOB TIMER B
39	SK-377735	KNOB REPEAT B
44	ZW-316800	EL30BRS TIN 5L
45	ZW-325519	EL30BRS TIN 8L BEND
46	SE-377737	FILTER DISPLAY
54	ZS-336613	PT PAN26X06STL CMT
55	SK-B377701A	KNOB PROGRAM(10+) B PART
56	SK-B377701B	KNOB PROGRAM(0) B PART
57	SK-B377701C	KNOB PROGRAM(1) B PART
58	SK-B377701D	KNOB PROGRAM(2) B PART
59	SK-B377701E	KNOB PROGRAM(3) B PART
60	SK-B377701F	KNOB PROGRAM(4) B PART
61	SK-B377701G	KNOB PROGRAM(5) B PART
62	SK-B377701H	KNOB PROGRAM(6) B PART
63	SK-B377701J	KNOB PROGRAM(7) B PART
64	SK-B377701K	KNOB PROGRAM(8) B PART

Ref. No.	Part No.	Description
65	SK-B377701L	KNOB PROGRAM(9) B PART
66	SK-B377703A	KNOB EDIT(1)(ALL CLEAR) B PART
67	SK-B377703B	KNOB EDIT(1)(PROGRAM) B PART
68	SK-B377703C	KNOB EDIT(1)(INDEX) B PART
69	SK-B377703D	KNOB EDIT(1)(B,S) B PART
70	SK-B377703E	KNOB EDIT(1)(F,S) B PART
71	SK-B377705A	KNOB EDIT(2)(L) B PART
72	SK-B377705B	KNOB EDIT(2)(R) B PART
73	SK-B377705C	KNOB EDIT(2)(DELETE) B PART
74	SK-B377705D	KNOB EDIT(2)(F,F) B PART
75	SK-B377705E	KNOB EDIT(2)(F,B) B PART
76	SK-377709	KNOB OPEN B
77	SK-377713A	KNOB PAUSE B
78	SK-377713B	KNOB STOP B
79	SK-377715	KNOB PLAY
81	SM-365756C	NAME PLATE AKA(K2)
82	ZW-653163	RING CS 280STL PKR
83	SE-378804J	MASK TOP
84	ZS-376523	ST BID30X06STL BNI EARTH LOCK
85	ZS-425992	CTS30X08STL BNI

16. ACCESSORY

Ref. No.	Part No.	Description
1	AX-377945	REMOCON RC-C93
2	EW-379713J	CORD OFC AU-P 1PCS
3	ZZ-374173	CORD *P2014

INDEX

Part No.	Ref. No.	Part No.	Ref. No.	Part No.	Ref. No.	Part No.	Ref. No.
AX-377945	1	ED-346552	D18	EI-355115	51	ES-349474	TS17
BA-P2026A120A	1A	ED-346552	D19	EI-355115	IC5	ES-349474	TS18
BA-P2026A120B	1B	ED-346552	D20	EI-360039	55	ES-349474	TS19
BA-P2026A120E	1C	ED-346552	D21	EI-360039	IC5	ES-349474	TS20
BA-P2026A130A	2A	ED-346558	23	EI-360040	54	ES-349474	TS21
BA-P2026A130B	2B	ED-346558	D16	EI-360040	IC4	ES-349474	TS22
BA-P2026A150A	3	ED-346568	24	EI-362588	50	ES-349474	TS23
BD-P2026A140A	33	ED-346568	D24	EI-362588	IC8	ES-349474	TS24
BM-328441	2	ED-346568	D25	EI-362588	IC101	ES-349474	TS25
BM-328441	60	ED-346591	25	EI-362975	43	ES-349474	TS26
BM-328441	73	ED-346591	D9	EI-362975	IC6	ES-349474	TS27
BM-377823	1	ED-356424	14	EI-367271	56	ES-349474	TS28
BM-377823	53	ED-356424	D22	EI-367271	IC1	ES-349474	TS29
BO-377825	3	ED-356424	D23	EI-368608	40	ES-349474	TS30
BO-377825	33	ED-356424	D26	EI-368608	IC201	ES-349474	TS31
BR-377659	67	ED-356424	D27	EI-368609	41	ES-377828J	65
BT-368261	12	ED-360409	16	EI-368609	IC9	ES-377828J	SW1
BT-368261	PT1	ED-360409	D1	EI-368610	42	ES-377848	66
BT-377803	11	ED-367576	21	EI-368610	IC1	ES-377848	SW101
BT-377803	4A	ED-367576	D16	EI-368611	45	ES-377867	67
BT-377805	9	ED-377845	13	EI-368611	IC2	ES-377867	SW1
BT-377805	4B	ED-377845	D1	EI-368612	53	ET-310148	89
BT-377806	10	ED-377845	D2	EI-368612	IC4	ET-310148	TR30
BT-377806	4C	ED-377845	D3	EI-374176	60	ET-318237	80
BT-377808	8	ED-377845	D4	EI-374176	X1	ET-318237	TR20
BT-377808	4D	ED-377861	31	EI-377191	52	ET-337891	74
BT-377809	7	ED-377861	IC1	EI-377191	IC6	ET-337891	PH401
BT-377809	6A	ED-377861	IC2	EI-377246	57	ET-337891	PH402
BT-377811	5	ED-377861	IC3	EI-377246	IC13	ET-338244	75
BT-377811	6B	ED-379184	19	EI-377767	46	ET-338244	TR2
BT-377812	6	ED-379184	D2	EI-377767	IC1	ET-338244	TR8
BT-377812	6C	ED-379184	D23	EI-377855	58	ET-348829	76
BT-377813	4	ED-379184	D24	EI-377855	IC3	ET-348829	TR6
BT-377813	6D	ED-379184	D25	EI-377857	39	ET-348829	TR12
BV-8375720	42	ED-379184	D12	EI-377857	IC8	ET-348829	TR19
EC-320548	C1A	ED-379184	D13	EI-377860	47	ET-348829	TR23
EC-320548	C2A	ED-379184	D14	EI-377860	IC12	ET-348830	82
EC-320548	C3A	ED-379184	D15	EI-380319J	48	ET-348830	TR3
EC-338411	C1B	ED-379184	D28	EI-380319J	IC7	ET-348830	TR9
EC-338411	C2B	ED-379184	D33	EJ-374191	P1	ET-348831	83
EC-338411	C3B	ED-379184	D34	EJ-377834	J11	ET-348831	TR5
EC-367928	C1C	EF-258344	35	EJ-377869	J2	ET-348831	TR11
ED-301911	17	EF-258344	F1B	EJ-380560J	J101	ET-348831	TR18
ED-301911	D3	EF-258344	F2B	EM-377851	61	ET-348831	TR22
ED-301911	D8	EF-308847	37	EM-377851	IN1	ET-349081	85
ED-301911	D20	EF-308847	F2A	EO-8375723	41	ET-349081	TR19
ED-301911	D5	EF-308847	F3A	EO-8375725	40	ET-349081	TR4
ED-301911	D6	EF-308847	F4A	EO-338409	L1	ET-349081	TR10
ED-301911	D7	EF-309392	36	EO-345913	L1	ET-349081	TR16
ED-301911	D9	EF-309392	F1A	EQ-348929	62	ET-349081	TR21
ED-301911	D17	EF-355226	32	EQ-348929	RL1	ET-349081	TR25
ED-330622	20	EF-355226	F3C	EQ-348929	RL2	ET-349718	78
ED-330622	D10	EF-355226	F4C	ER-322332	R71	ET-349718	TR201
ED-330622	D11	EF-358641	33	ER-371844	IB4	ET-352726	79
ED-330622	D12	EF-358641	F1C	ER-378672J	R59	ET-352726	TR11
ED-330622	D13	EF-358641	F2C	ER-378672J	R60	ET-352726	TR1
ED-330622	D17	EF-623103	34	ES-344253	63	ET-352726	TR7
ED-330622	D18	EF-623103	F3B	ES-344253	24	ET-352726	TR17
ED-330622	D10	EF-623103	F4B	ES-344257	64	ET-352726	TR20
ED-330622	D11	EH-348116	IB5	ES-344257	77	ET-352726	TR24
ED-330962	26	EH-348116	IB6	ES-344257	78	ET-352726	TR31
ED-330962	D6	EH-352061	IB1	ES-349464	68	ET-353899	77
ED-330962	D7	EH-364919	IB3	ES-349464	VS1	ET-353899	TR18
ED-337413	15	EH-378669J	IB2	ES-349474	69	ET-354083	86
ED-337413	D301	EH-380185J	38	ES-349474	TS1	ET-354083	TR6
ED-338333	27	EH-380185J	FL901	ES-349474	TS2	ET-354083	TR8
ED-338333	D19	EH-380185J	FL1	ES-349474	TS3	ET-354083	TR613
ED-343410	28	EH-380185J	FL2	ES-349474	TS4	ET-356817	81
ED-343410	D8	EH-380185J	FL3	ES-349474	TS5	ET-356817	TR7
ED-344280	18	EH-380185J	FL101	ES-349474	TS6	ET-356817	TR9
ED-344280	D4	EI-336794	44	ES-349474	TS7	ET-356817	TR14
ED-344280	D5	EI-336794	IC2	ES-349474	TS8	ET-360067	84
ED-344280	D14	EI-336794	IC3	ES-349474	TS9	ET-360067	TR1
ED-344280	D15	EI-336794	IC4	ES-349474	TS10	ET-360067	TR3
ED-346526	29	EI-336794	IC5	ES-349474	TS11	ET-360067	TR4
ED-346526	D35	EI-349372	59	ES-349474	TS12	ET-360067	TR5
ED-346526	D36	EI-349372	X2	ES-349474	TS13	ET-360067	TR10
ED-346545	30	EI-349719	49	ES-349474	TS14	ET-360067	TR12
ED-346545	D1	EI-349719	IC10	ES-349474	TS15	ET-360067	TR17
ED-346552	22	EI-349719	IC11	ES-349474	TS16	ET-360067	TR21

ABBREVIATIONS (COMPACT DISC)

ABBREVIATION	EXPLANATION	ABBREVIATION	EXPLANATION
A-D	Analog to Digital (Convertor)	Mb	Mega Bits
ADC	Analog to Digital (Convertor)	MDA	Modulation
BCD	Binary Code Decimal	MFM	Modified Frequency Modulation
BPI	Bits per Inch	MM	Mono-stable Multivibrator
CD	Compact Disc	M : FM	Modified Modified Frequency Modulation
CIRC	Cross Interleaving & Reed Solomon Coding	MOD 2	Module 2 (Addition)
CLV	Constant Linear Velocity	MP	Microprocessor
CP	Clock Pulses	MSB	Most Significant Bit
CRCC	Cyclic Redundancy Check Codes	NA	Numerical Aperture
D Level	Decision Level	NRZ	Non Return to Zero
D-A	Digital to Analog (Convertor)	NRZ-I	Non Return to Zero Inverted
DAC	Digital to Analog (Convertor)	P	Parity Data
DAD	Digital Audio Disk	PAM	Pulse Amplitude Modulation
DEM	Dynamic Element Matching	PCM	Pulse Code Modulation
DPD	Differential Phase Detection	PD	Phase Detector
DSV	Digital Sum Value	PE	PHASE Encode
EFM	Eight to Fourteen Modulation	PLL	Phase Locked Loop
EX-OR	EXclusive OR	PNM	Pulse Number Modulation
FIC	Flux Changes per Inch	PPM	Pulse Phase Modulation
FIR	Finite Impulse Response	PWM	Pulse Width Modulation
FP	Front Pulse	Q	Parity Data
FPG	Front Pulse Gate	R.R., R., etc	Data for Right Channel
f	Frequency of Sampling	RAM	Random Access Memory
GF	Galois Field	RPG	Rear Pulse Gate
H & V (Parity)	Horizontal & Vertical	SCOOP	Self Coupled Optical Pick-up
IIR	Infinte Impulse Response	S & H	Sample & Hold
kb	Kilo Bits	S/N	Signal to Noise Ratio
L.L ₁ , L ₂ , etc	Data for Left Channel	SSG	Standerd Signal Generator
LPF	Low Pass Filter	SYS CON	SYSTEM CONTROL
LSB	Least Significant Bit		

AKAI ELECTRIC CO., LTD.

12-14, 2-Chome, Higashi-Kojiya, Ohta-ku, Tokyo, Japan
 TEL: Tokyo (742) 5111 CABLE: HIFIAKAI TOKYO TELEX: J26261
 Printed No. 871221-G1-2400 Printed Date: February 2, 1988

350 Printed in Japan

Part No.	Ref. No.	Part No.	Ref. No.	Part No.	Ref. No.	Part No.	Ref. No.
ET-365456	87	SK-B377703B	67	ZW-378813J	11		
ET-365456	TR2	SK-B377703C	68	ZW-653163	82		
ET-370634	72	SK-B377703D	69	ZZ-374173	3		
ET-370634	TR15	SK-B377703E	70				
ET-370809	88	SK-B377705A	71				
ET-370809	TR101	SK-B377705B	72				
ET-371075	71	SK-B377705C	73				
ET-371075	TR13	SK-B377705D	74				
ET-373485	73	SK-B377705E	75				
ET-373485	TR14	SK-373236B	18				
ET-379553J	70	SK-377709	76				
ET-379553J	K9	SK-377713A	77				
EV-356577	VR201	SK-377713B	78				
EV-356582	VR2	SK-377715	79				
EV-357619	VR1	SK-377733	37				
EV-358829	VR2	SK-377734	38				
EV-358829	VR3	SK-377735	39				
EV-358829	VR202	SM-365756C	81				
EV-378744J	90	SP-377742	11				
EV-378744J	VR101	SP-377745	1				
EV-380682J	VR1	SP-377747	29				
EW-363634	23B	SP-377748	30				
EW-363659	23A	SP-380716J2	21A				
EW-363672	23C	SP-380718J2	21B				
EW-363684	23D	SP-380719J2	21C				
EW-379713J	2	SP-380720J2	21D				
MB-375732	35	SP-380721J2	21E				
MB-375733	50	SZ-377677	16				
MB-377660	91	SZ-377682	9				
MB-377660	62	SZ-377791	68				
MB-377661	92	ZG-351817	85				
MB-377661	63	ZG-358111	15				
MB-377790	93	ZG-375734	55				
MB-377790	64	ZG-377680	70				
MB-378682J	22	ZG-379839J	27				
ML-377647A	13	ZG-381284J	83				
ML-377652	20	ZG-381312J	47				
ML-377653	21	ZS-332009	36				
ML-377688	29	ZS-332468	27				
ML-377689	17	ZS-336613	54				
ML-380551J1	14	ZS-345319	86				
MR-345182	59	ZS-350934	26				
MR-377657	66	ZS-355149	2				
MR-377658	69	ZS-355511	17				
MS-375730	34	ZS-376365	31				
MS-377649A	18	ZS-376365	61				
MS-380550J1	19	ZS-376365	15				
MV-368886	84	ZS-376523	26				
MZ-352143	94	ZS-376523	84				
MZ-352143	74	ZS-376576	79				
MZ-375728	38	ZS-377153	9				
MZ-375729	39	ZS-377679	44				
MZ-377645	48	ZS-377688	10				
MZ-377646	46	ZS-377746	3				
MZ-377656	82	ZS-377926	32				
MZ-377667	95	ZS-377928	25				
MZ-377667	72	ZS-377929	10				
MZ-377671	3	ZS-377930	56				
MZ-377826	4	ZS-377930	76				
SA-B377816	19	ZS-378680J	37				
SC-B377673	5	ZS-378683J	49				
SC-P2026A060A	7	ZS-378733J	2				
SC-377654	80	ZS-378741J	28				
SC-377655	81	ZS-378743J	26				
SC-377675	8	ZS-380284J	32				
SE-375348	22	ZS-380701J	12				
SE-377737	46	ZS-416687	5				
SE-378804J	83	ZS-425992	85				
SK-B377701A	55	ZS-552824	20				
SK-B377701B	56	ZS-590128	54				
SK-B377701C	57	ZW-259503	28				
SK-B377701D	58	ZW-270088	65				
SK-B377701E	69	ZW-270101	1				
SK-B377701F	60	ZW-270101	71				
SK-B377701G	61	ZW-316800	44				
SK-B377701H	62	ZW-325519	45				
SK-B377701J	63	ZW-376292	31				
SK-B377701K	64	ZW-376391	23				
SK-B377701L	65	ZW-377824	45				
SK-B377703A	66	ZW-378397	36				

AKAI

MODEL CD-93

SCHEMATIC DIAGRAM AND PC BOARDS

TABLE OF CONTENTS

1. POWER AND HP PC BOARDS	2
2. CONNECTION DIAGRAM	3
3. DIGITAL SCHEMATIC DIAGRAM	4
4. DIGITAL AND OTHER PC BOARDS	5
5. ANALOG SCHEMATIC DIAGRAM	6
6. ANALOG PC BOARD	7
7. OPERATION SCHEMATIC DIAGRAM	8
8. OPERATION PC BOARD	9
9. ANALOG BLOCK DIAGRAM	10
10. BLOCK DIAGRAM	11
11. IC'S	12

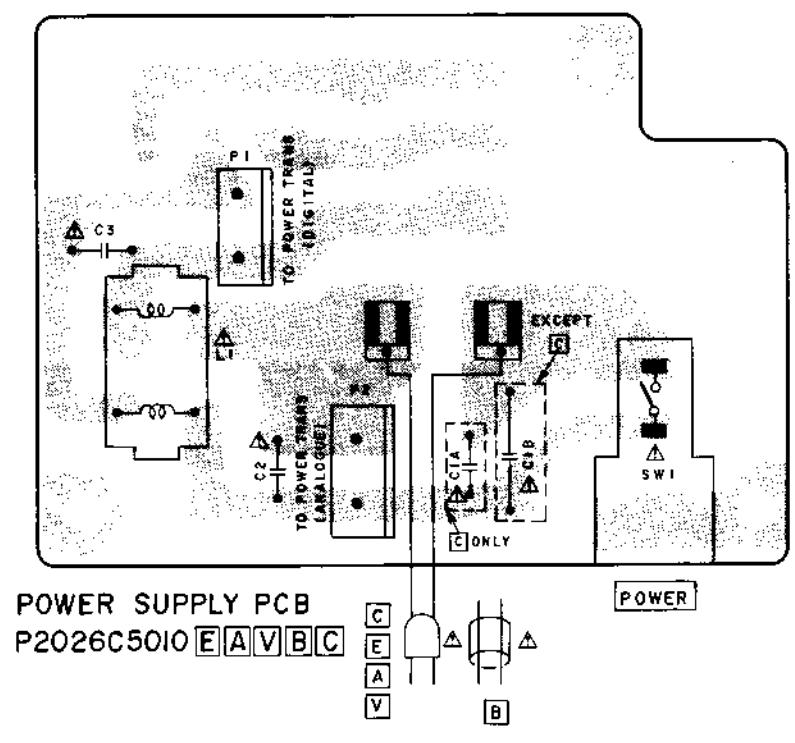
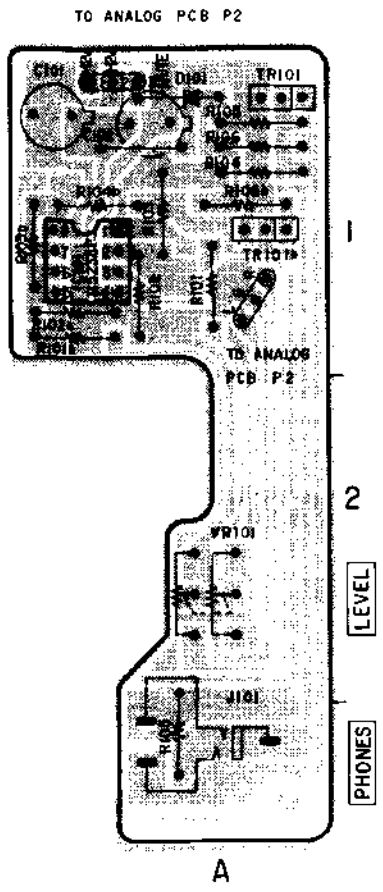

H.P PCB P2026A5038

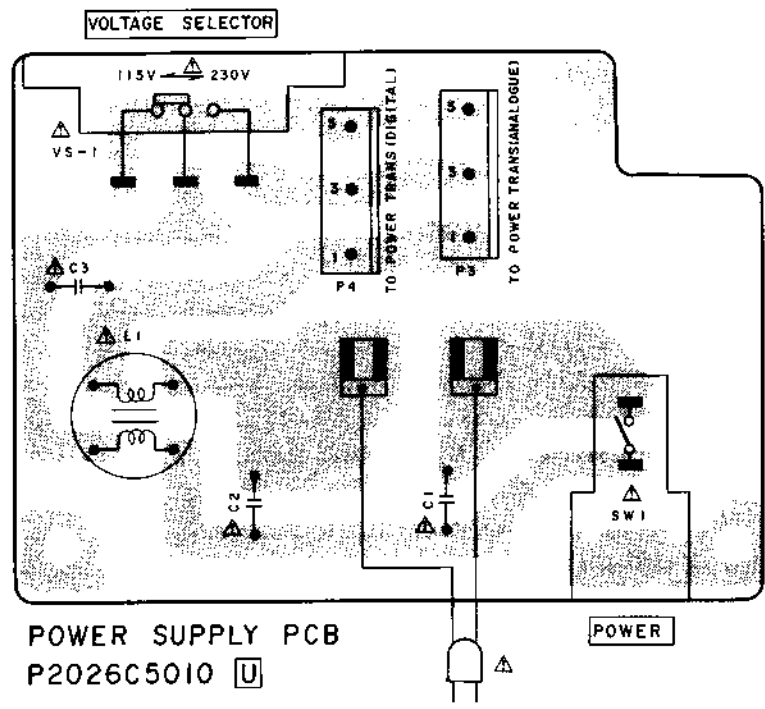

WARNING ⚠ INDICATES SAFETY CRITICAL COMPONENTS FOR CONTINUED SAFETY. REPLACE SAFETY CRITICAL COMPONENTS ONLY WITH MANUFACTURER'S RECOMMENDED PARTS

AVERTISSEMENT ⚠ IL INDIQUE LES COMPOSANTS CRITIQUES DE SÉCURITÉ POUR MAINTENIR LE DEGRÉ DE SÉCURITÉ DE L'APPAREIL. NE REMPLACER QUE DES PIÈCES RECOMMANDÉES PAR LE FABRICANT

A B C D E F

1

2

3

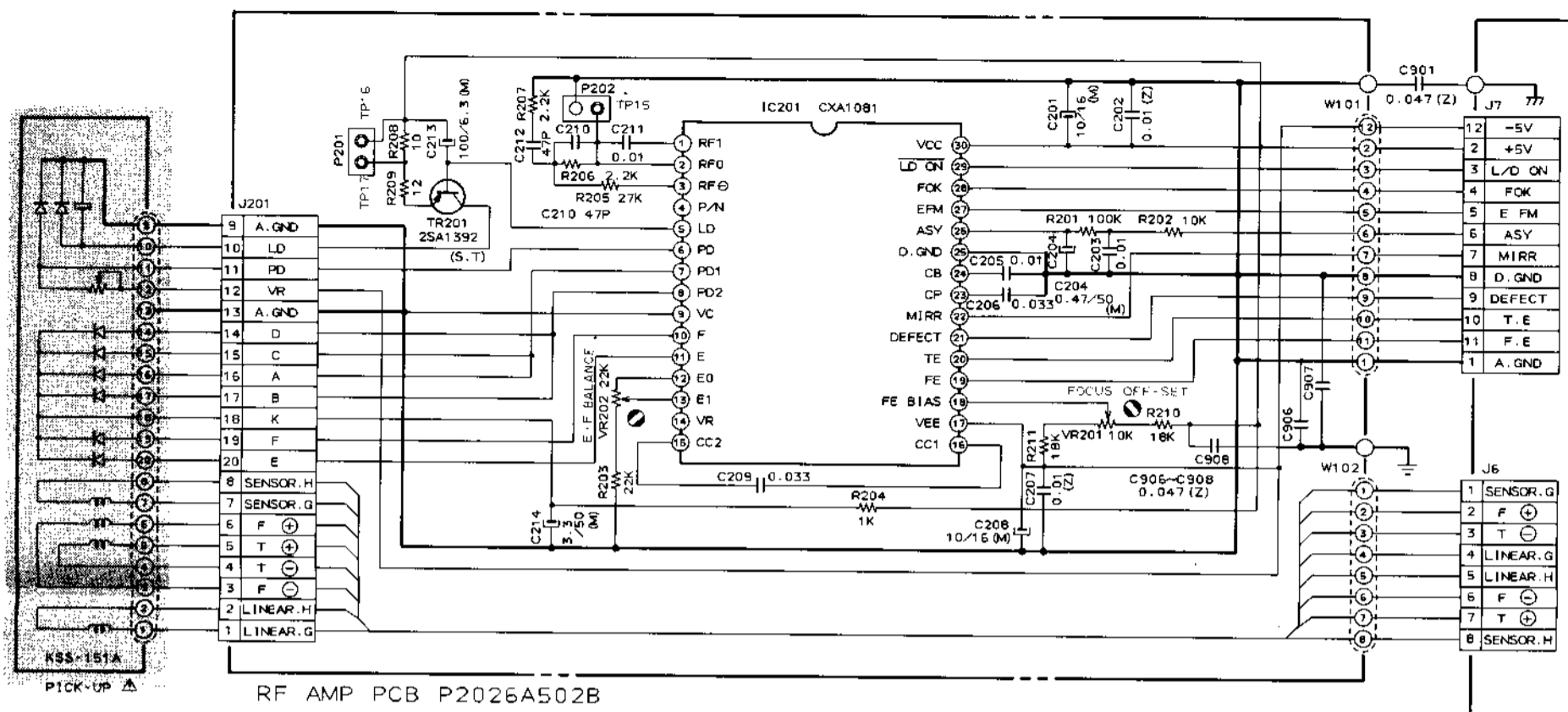

RF AMP PCB P2026A502B

4

5

6

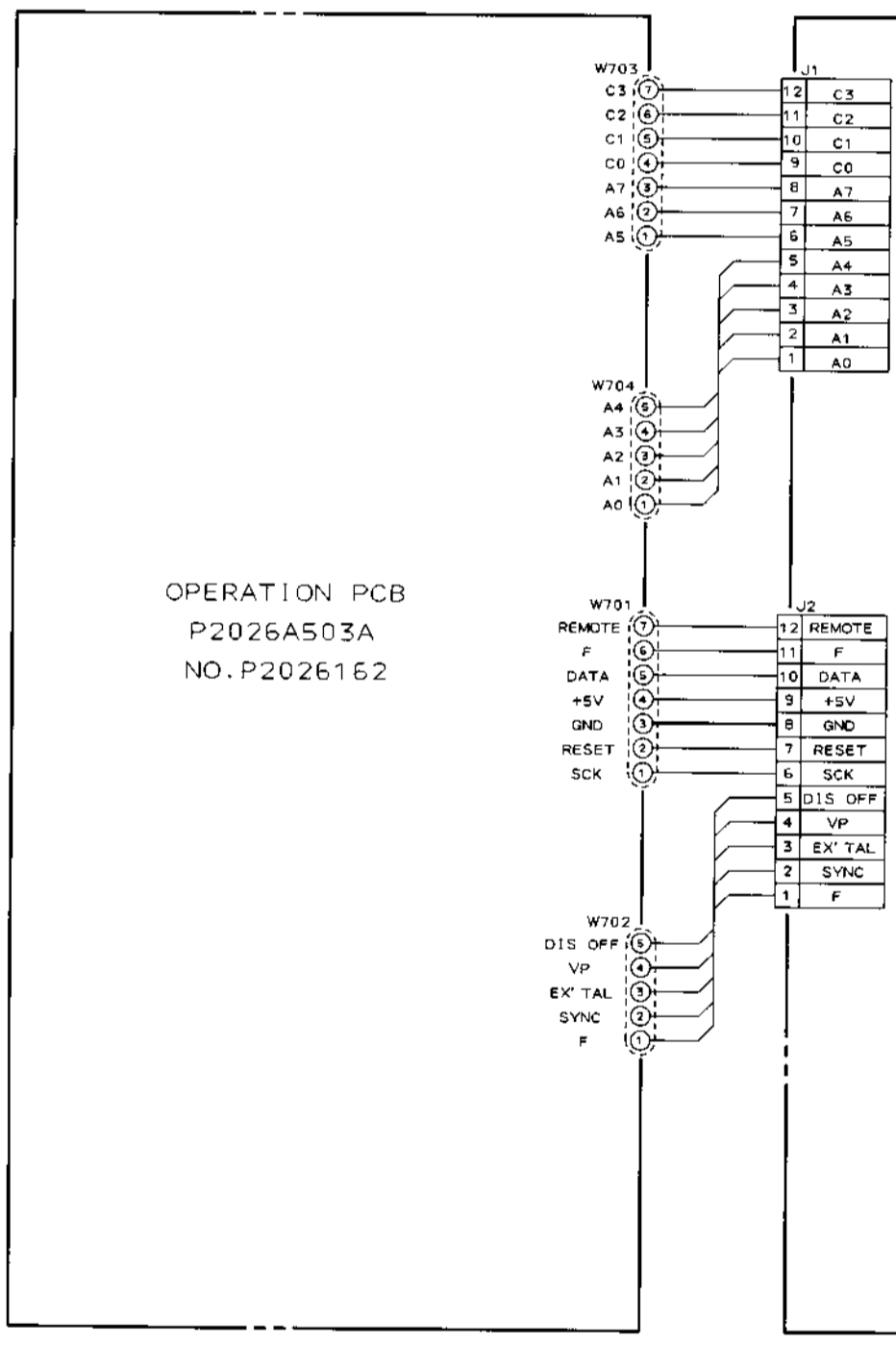

OPERATION PCB
P2026A503A
NO. P2026162

DIGITAL PCB
P2026A502A
NO. P2026161

7

8

WARNING AND INDICATE SAFETY CRITICAL COMPONENTS FOR CONTINUED SAFETY. REPLACE SAFETY CRITICAL COMPONENTS ONLY WITH MANUFACTURER'S RECOMMENDED PARTS.
AVERTISSEMENT: ET ILS INDIQUENT LES COMPOSANTS CRITIQUES DE SECURITE POUR MAINTENIR LE DEGRE DE SECURITE DE L'APPAREIL. NE REMPLACER QUE DES PIECES RECOMMANDEES PAR LE FABRICANT.

CLAMP MOTOR
RF-510T (12620)

LOADING MOTOR
RF-510T (12620)

SPINDLE MOTOR
BHR-2600C

TIMER SW
PCB
P2026A503C

PHOTO SEN.
IP2026A 503D
IP2026A 502C

A B C D E F

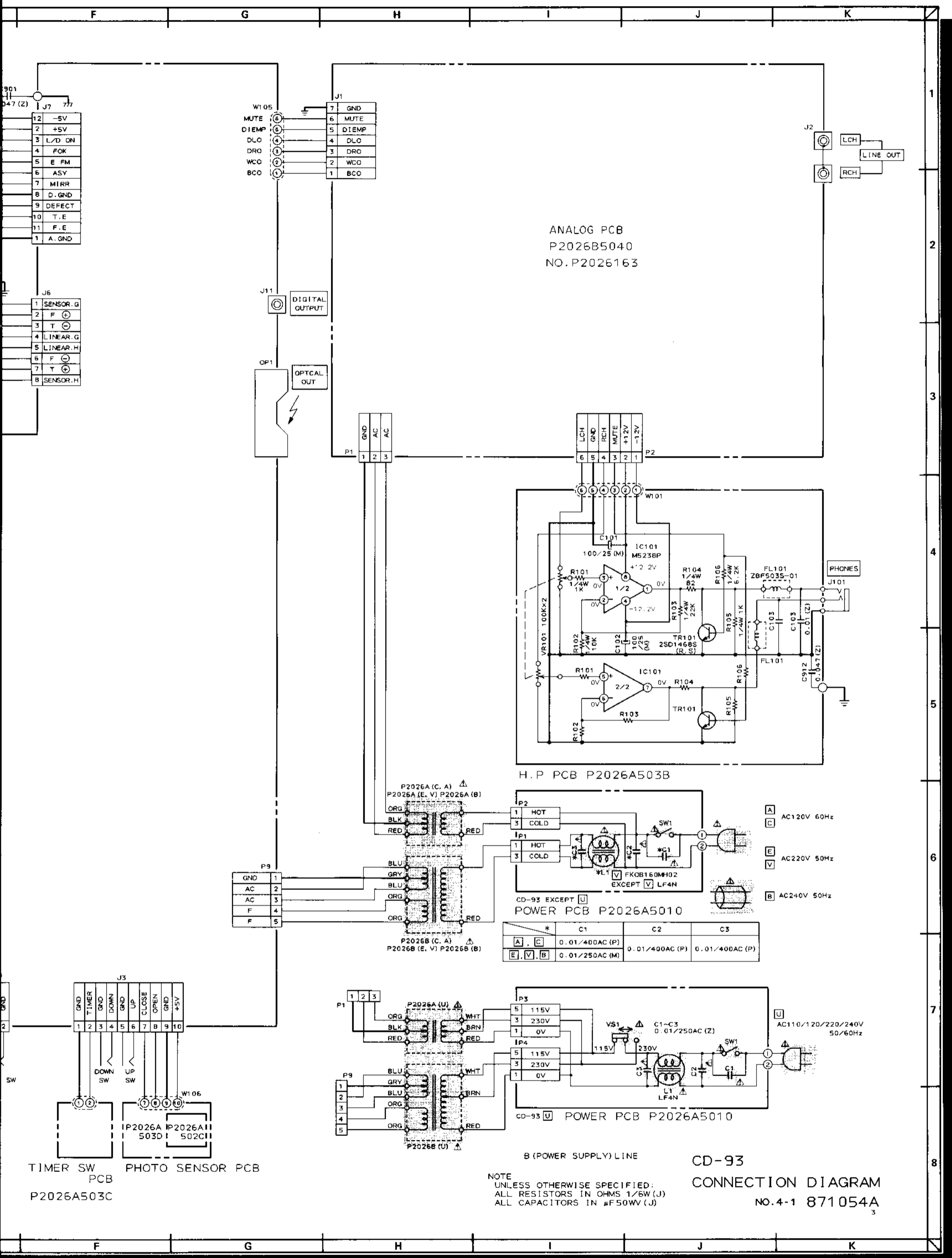

NOTE
UNLESS OTHERWISE SPECIFIED:
ALL RESISTORS IN OHMS 1/5W(J)
ALL CAPACITORS IN μ F50WV(J)

	C1	C2	C3
A, C	0.01/400AC (P)	0.01/400AC (P)	0.01/400AC (P)
E, V, B	0.01/250AC (M)		

- A AC120V 60Hz
- C AC220V 50Hz
- E AC240V 50Hz

U AC110/120/220/240V
50/60Hz

1
2
3
4
5
6
7
8

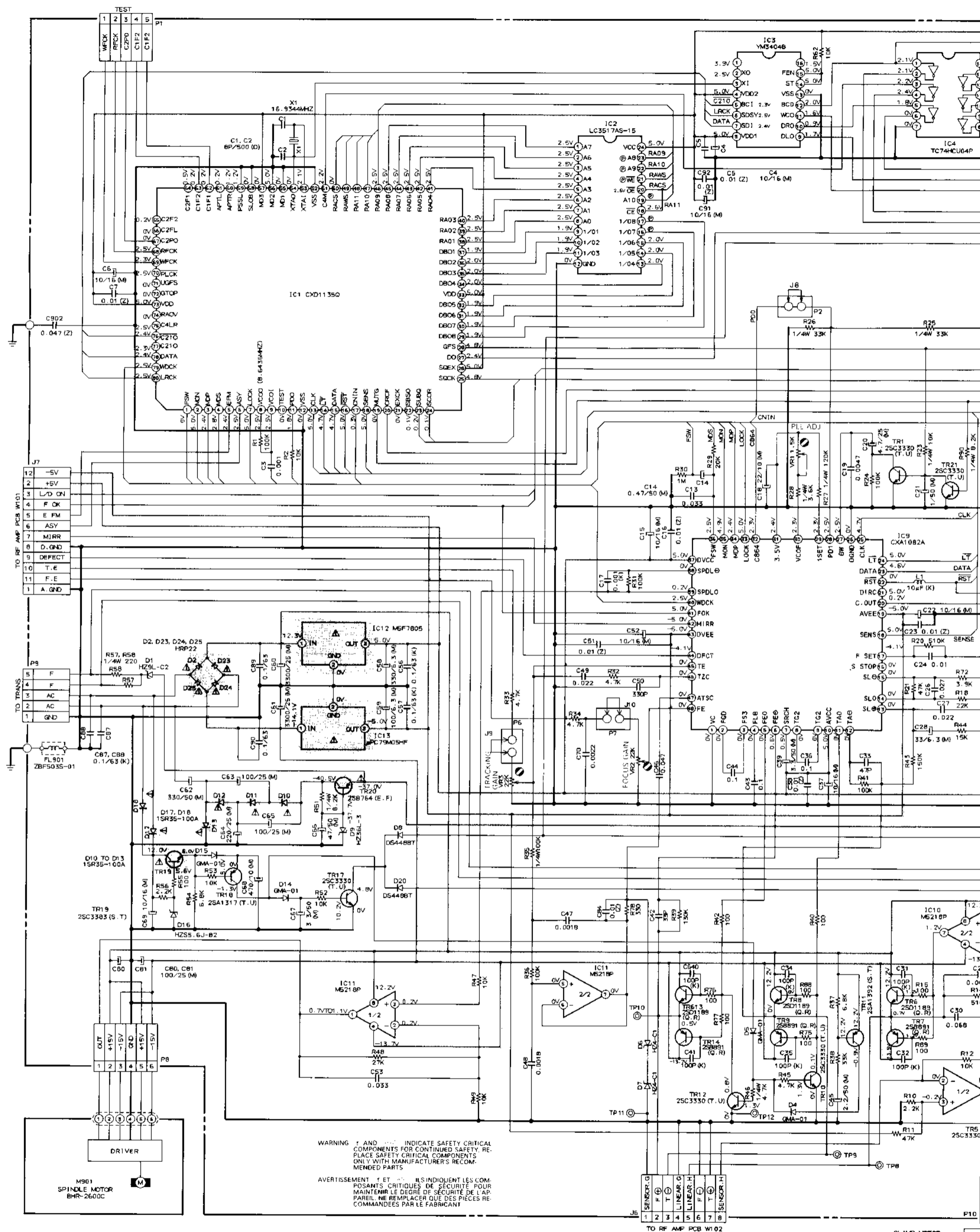

WARNING * AND * INDICATE SAFETY CRITICAL COMPONENTS FOR CONTINUED SAFETY. REPLACE SAFETY CRITICAL COMPONENTS ONLY WITH MANUFACTURER'S RECOMMENDED PARTS.

AVERTISSEMENT * ET * ILS INDICENT LES COMPOSANTS CRITIQUES DE SÉCURITÉ POUR MAINTENIR LE DEGRÉ DE SÉCURITÉ DE L'APPAREIL. NE REMPLACER QUE DES PIÈCES RECOMMANDÉES PAR LE FABRICANT.

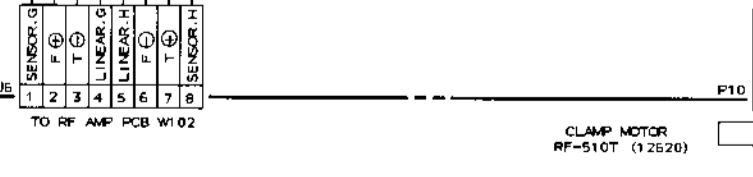

CLAMP MOTOR RF-510T (12520)

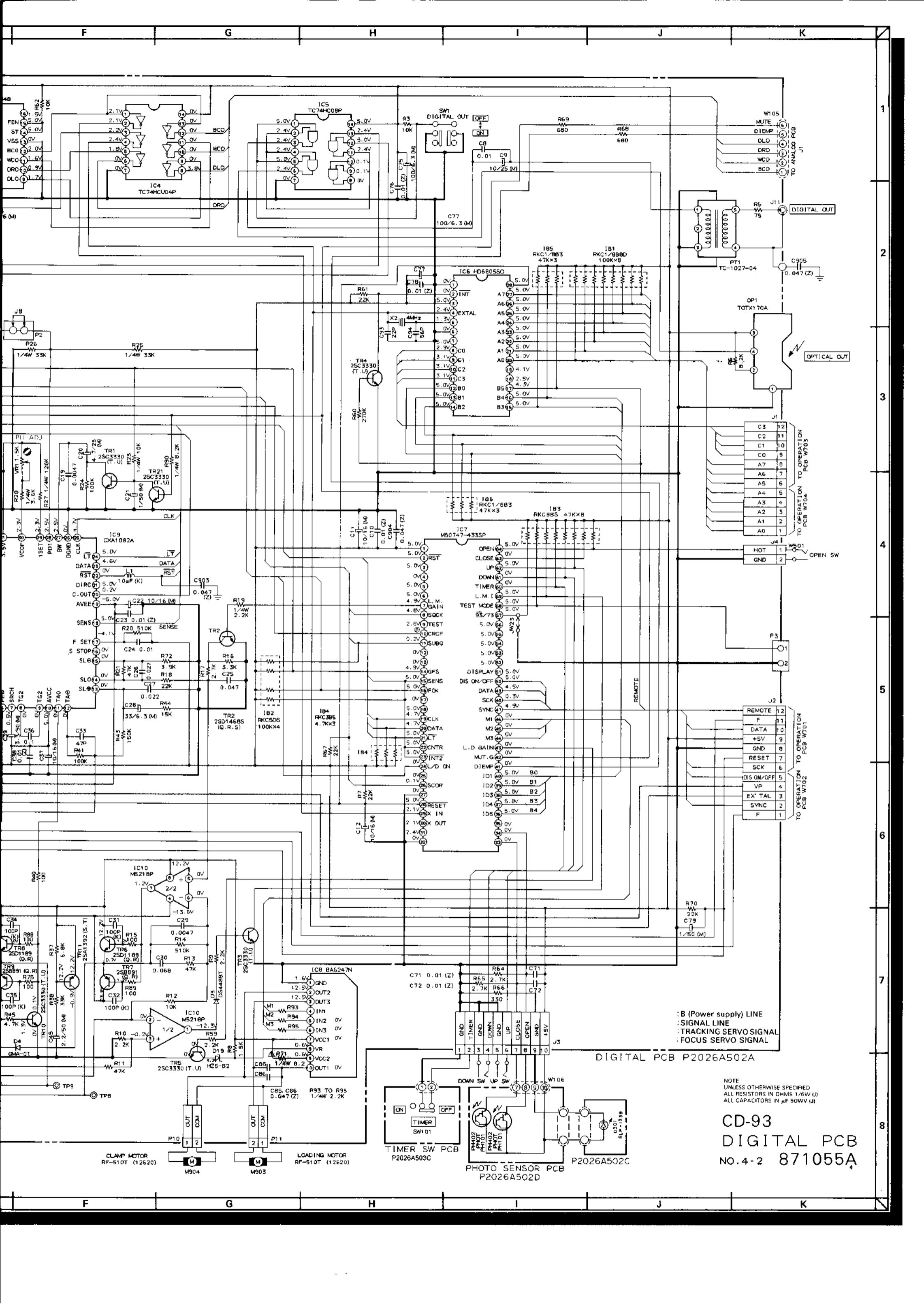

NOTE
UNLESS OTHERWISE SPECIFIED
ALL RESISTORS IN OHMS 1/6W (J)
ALL CAPACITORS IN μ F 50WV (J)

CD-93
DIGITAL PCB
No. 4-2 871055A

: B (Power supply) LINE
: SIGNAL LINE
: TRACKING SERVO SIGNAL
: FOCUS SERVO SIGNAL

DIGITAL PCB P2026A502A

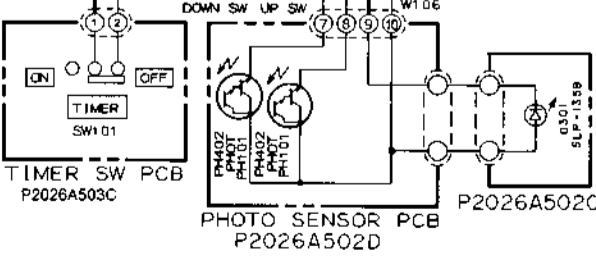

CLAMP MOTOR RF-510T (12620) M904
LOADING MOTOR RF-510T (12620) M903

1
2
3
4
5
6
7
8

F G H I J K

F G H I J K

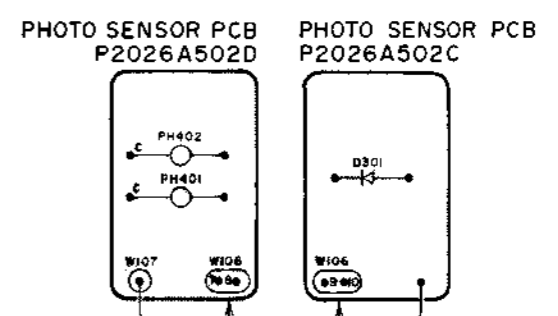
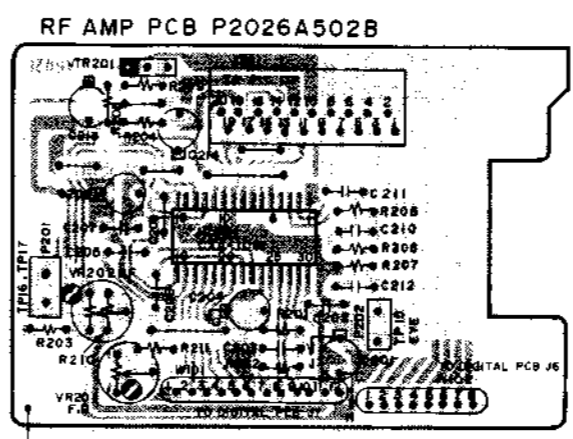
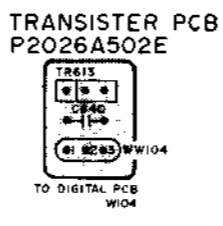
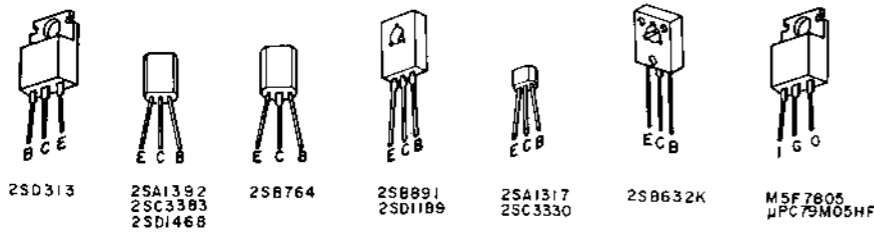

LOCATION OF COMPONENTS

- ICs
IC1...F4
IC2...G4
IC3...F4
IC4...B4
IC5...G3
IC6...A2
IC7...C3
IC8...B3
IC9...E4
IC10...C3
IC11...D2
IC12...E1
IC13...F2

- TRANSISTORS
TR1...F4
TR2...C4
TR3...B3
TR4...A1
TR5...B3
TR6...D3
TR7...D3
TR8...B2
TR9...B2
TR10...C2
TR11...F2
TR12...C2
TR13...C2
TR14...C1
TR15...E2
TR16...D2
TR17...F2
TR18...F3
TR19...F3
TR20...E1
TR21...E4

- CONNECTORS
J1...A2
J2...A3
J3...A1
J4...A1
J5...A1
J6...B1
J7...B1
J8...E2
J9...C1
J10...C1
J11...G1

- P1...F1
P2...E2
P3...A4
P6...C1
P7...C1
P8...D2
P9...G1
P10...B2
P11...C2
P12...E2
OP1...G1

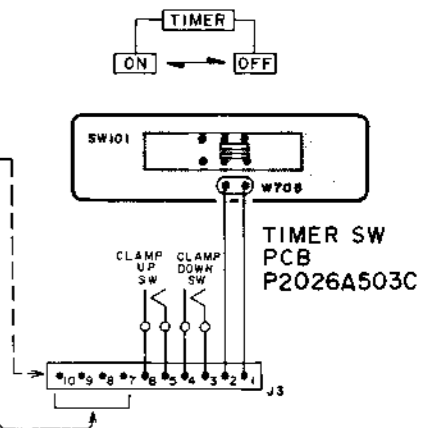
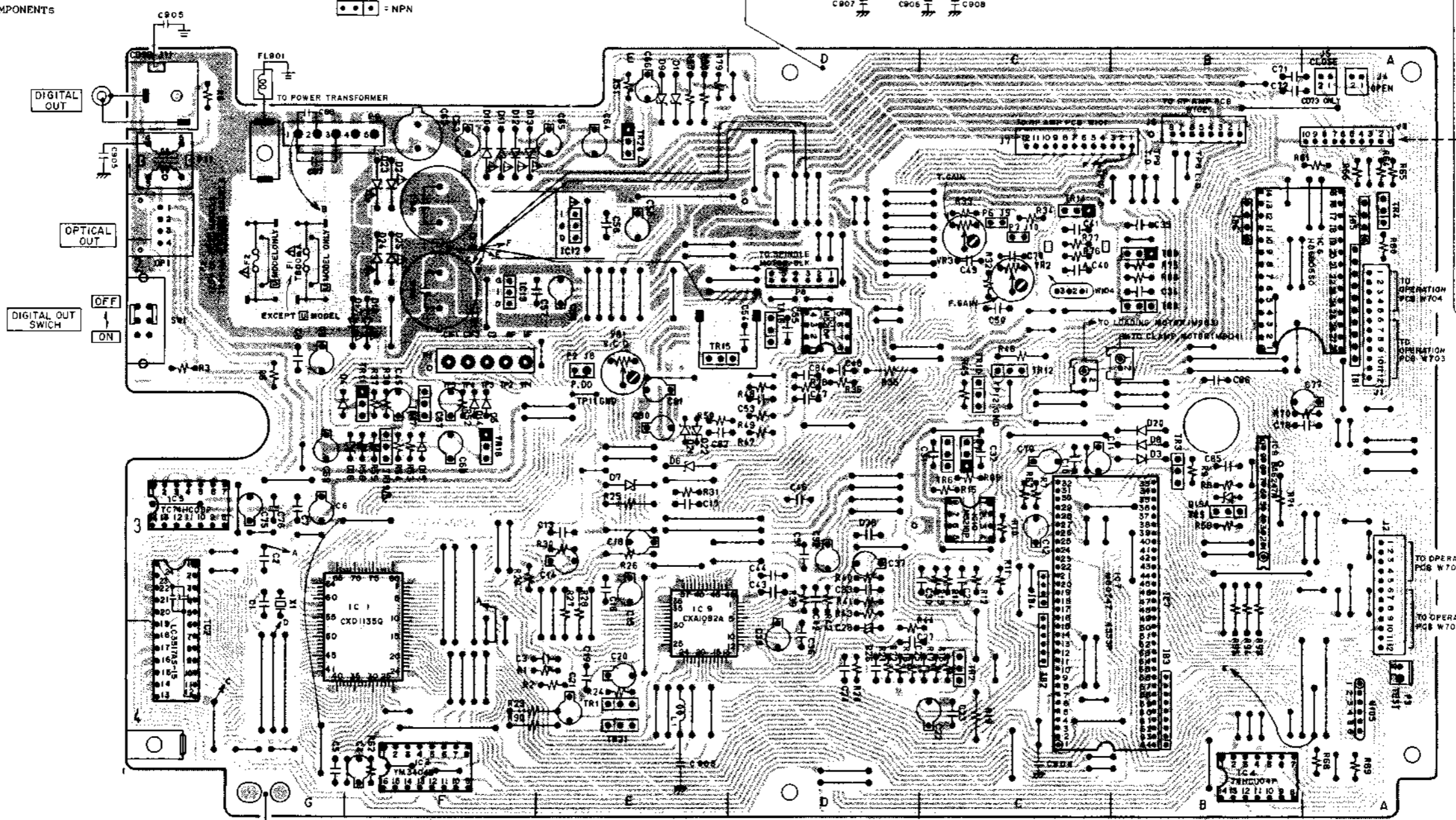

WARNING ⚠ INDICATES SAFETY CRITICAL COMPONENTS FOR CONTINUED SAFETY. REPLACE SAFETY CRITICAL COMPONENTS ONLY WITH MANUFACTURER'S RECOMMENDED PARTS.

AVERTISSEMENT ⚠ IL INDIQUE LES COMPOSANTS CRITIQUES DE SÉCURITÉ. POUR MAINTENIR LE DEGRÉ DE SÉCURITÉ DE L'APPAREIL, NE REMPLACER QUE DES PIÈCES RECOMMANDÉES PAR LE FABRICANT.

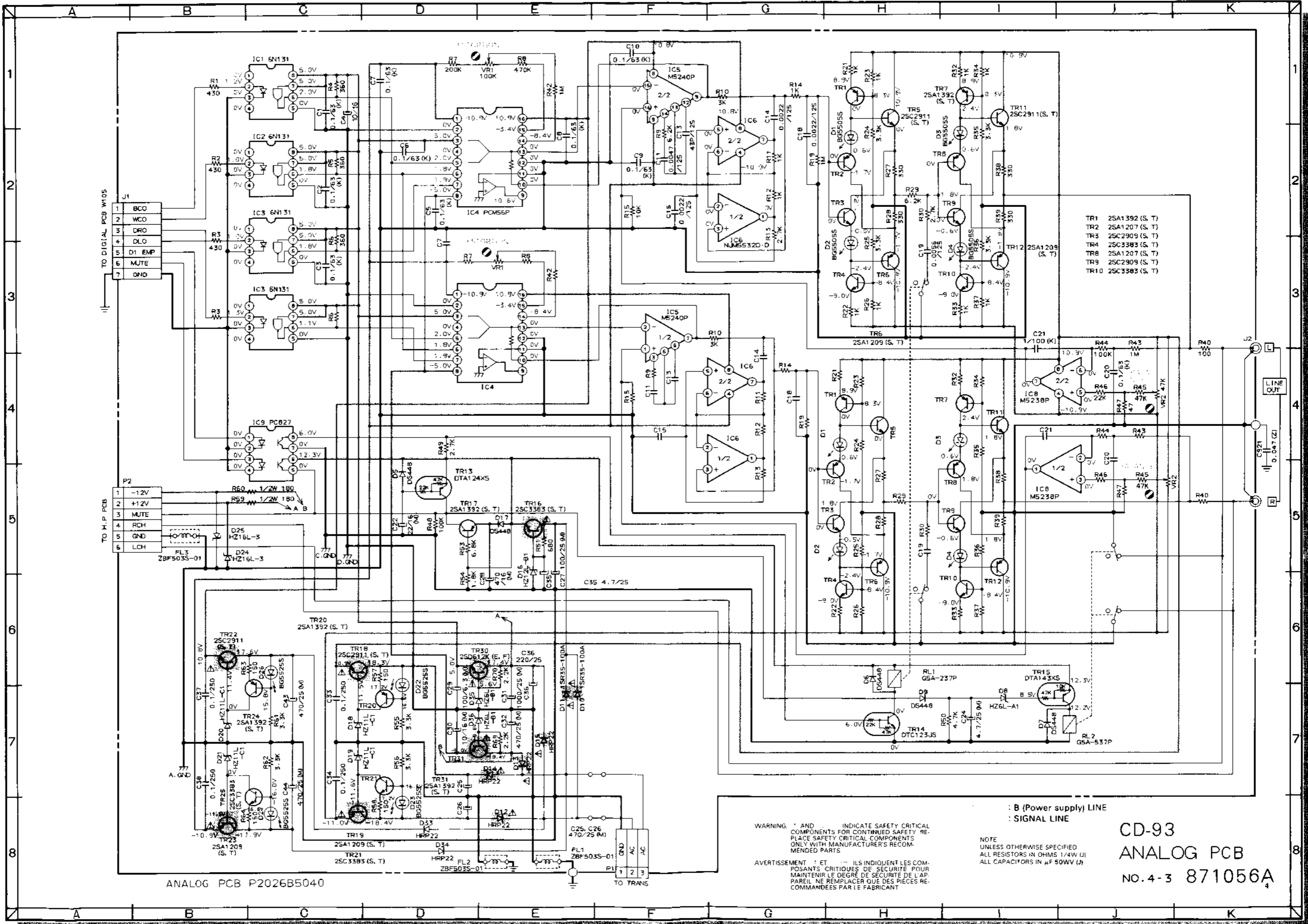

ANALOG PCB P2026B5040

WARNING: * AND * INDICATE SAFETY CRITICAL COMPONENTS FOR CONTINUED SAFETY. REPLACE SAFETY CRITICAL COMPONENTS ONLY WITH MANUFACTURER'S RECOMMENDED PARTS.

AVERTISSEMENT: * ET * ILS INDICENT LES COMPOSANTS CRITIQUES DE SECURITE POUR MAINTENIR LE DEGRE DE SECURITE DE L'APPAREIL. NE REMPLACER QUE DES PIECES RECOMMANDEES PAR LE FABRICANT.

: B (Power supply) LINE
: SIGNAL LINE

CD-93
ANALOG PCB
NO. 4-3 871056A

- TR1 2SA1392 (S, T)
- TR2 2SA1207 (S, T)
- TR3 25C2909 (S, T)
- TR4 25C3383 (S, T)
- TR8 2SA1207 (S, T)
- TR9 25C2909 (S, T)
- TR10 25C3383 (S, T)

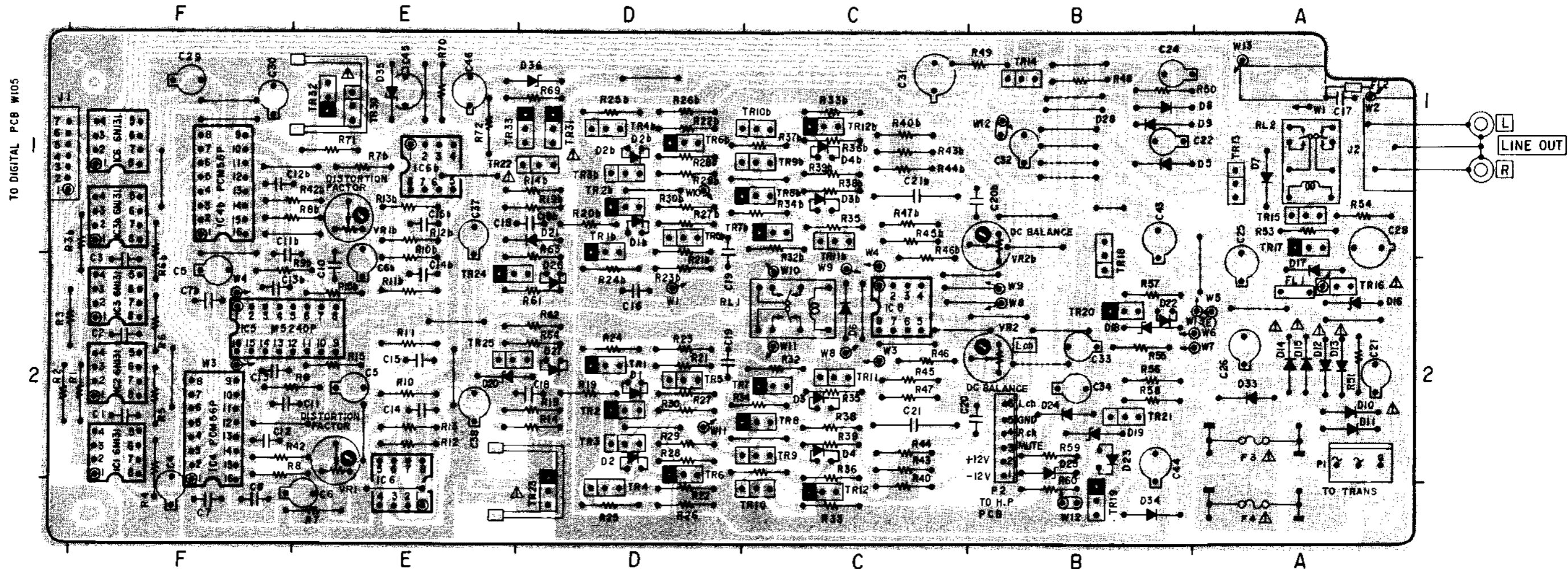

ANALOG PCB P2026B5040 (JI)

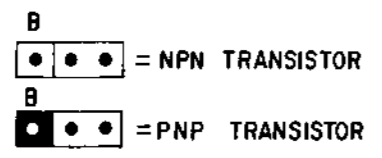

- TRANSISTOR
 TR1 ~ 6, 23 D2
 TR16 A2
 TR19 ~ 20 B2
 TR7 ~ 12 C2
 TR24, 25 E2
 TR1b ~ 6b D1
 TR7b ~ 11b C1
 TR14, 18 B1
 TR17 A1
 TR22, 31, 33 D1
 TR30, 32 E1

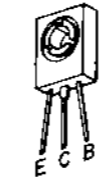

- 2SC2911 (S.T)
 2SA1209 (S.T)
 2SD6124 (E.T)

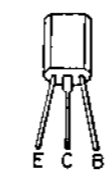

- 2SA1392 (S.T)
 2SC3383 (S.T)

	E	V	B	C	A
F3	T1A	250V	1.6A	125V	
F4	T1A	250V	1.6A	125V	

WARNING: Δ INDICATES SAFETY CRITICAL COMPONENTS. FOR CONTINUED SAFETY, REPLACE SAFETY CRITICAL COMPONENTS ONLY WITH MANUFACTURER'S RECOMMENDED PARTS.
 AVERTISSEMENT: Δ IL INDIQUE LES COMPOSANTS CRITIQUES DE SÉCURITÉ. POUR MAINTENIR LE DEGRÉ DE SÉCURITÉ DE L'APPAREIL, NE REMPLACER QUE DES PIÈCES RECOMMANDÉES PAR LE FABRICANT.

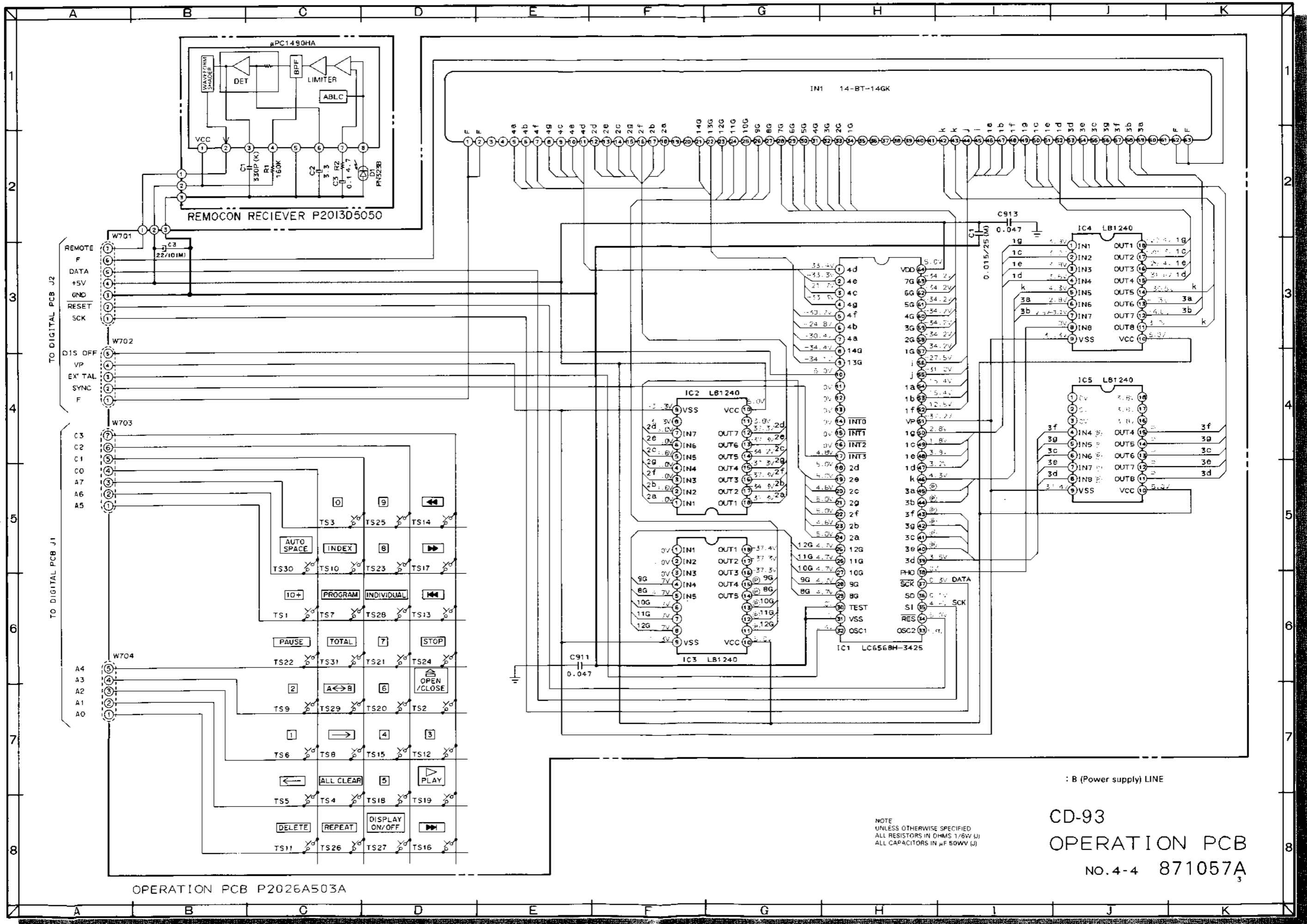

: B (Power supply) LINE

NOTE
UNLESS OTHERWISE SPECIFIED
ALL RESISTORS IN OHMS 1/8W (J)
ALL CAPACITORS IN uF 50WV (J)

CD-93
OPERATION PCB
NO. 4-4 871057A
3

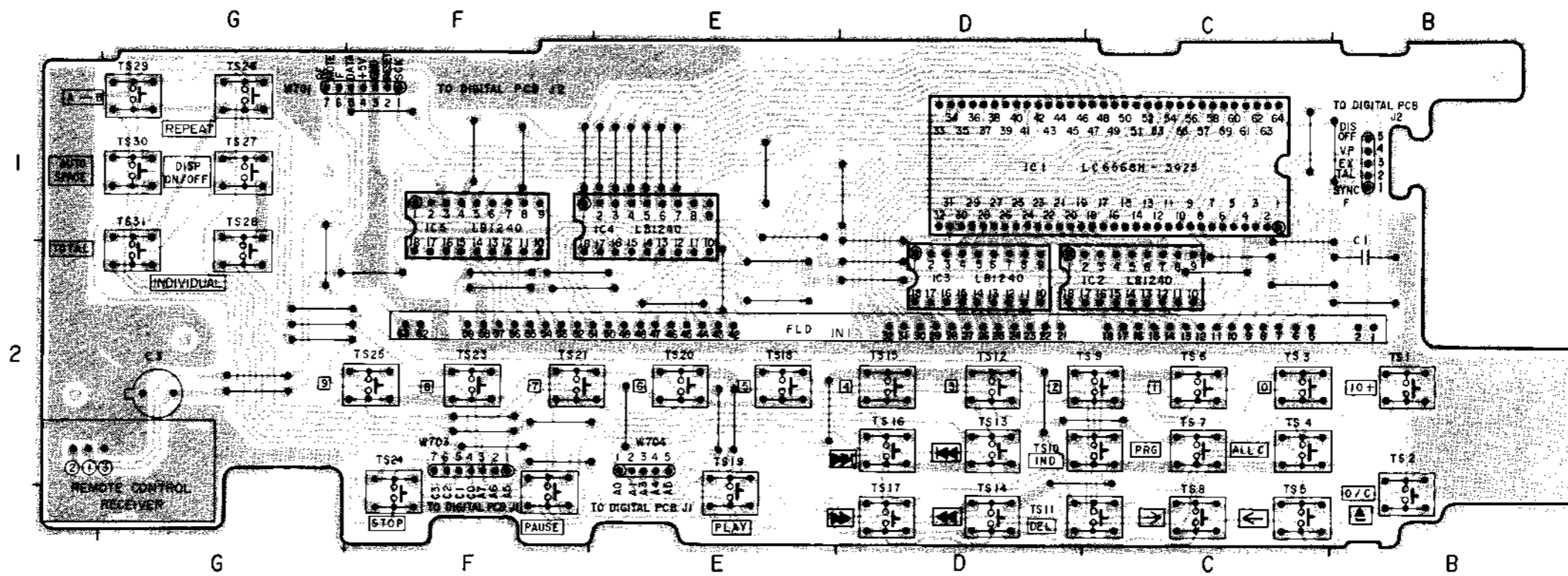

OPERATION PCB P2026A503A

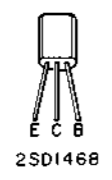

●●● = NPN TRANSISTOR

CD-93

When playing back a 1KHz
of the test disc TYPE III.

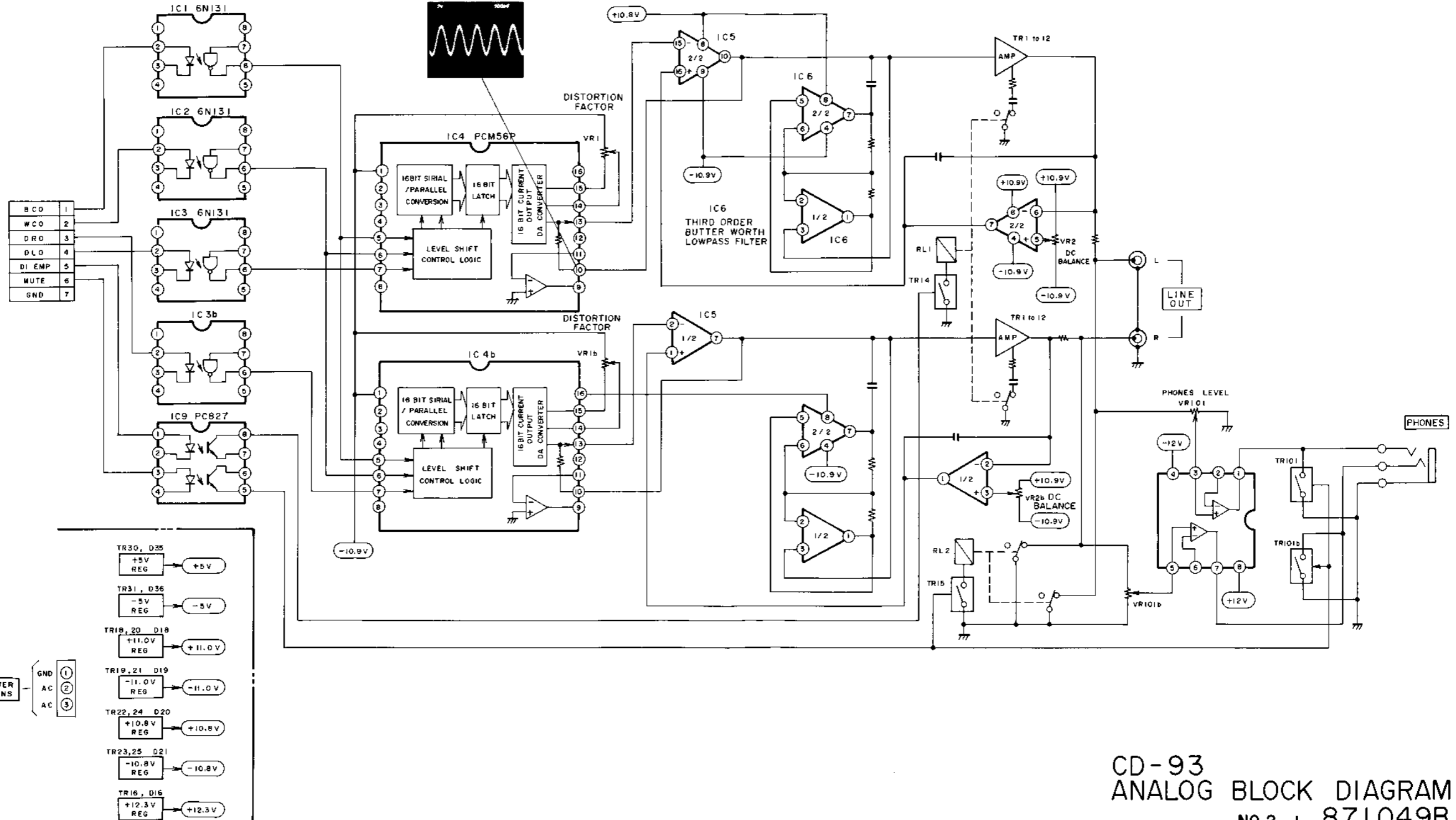

CD-93
ANALOG BLOCK DIAGRAM
NO.2-1 871049B

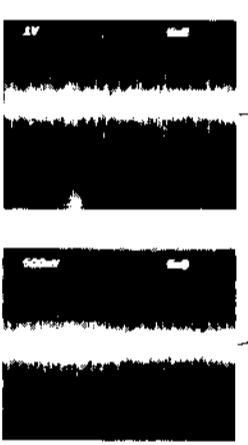
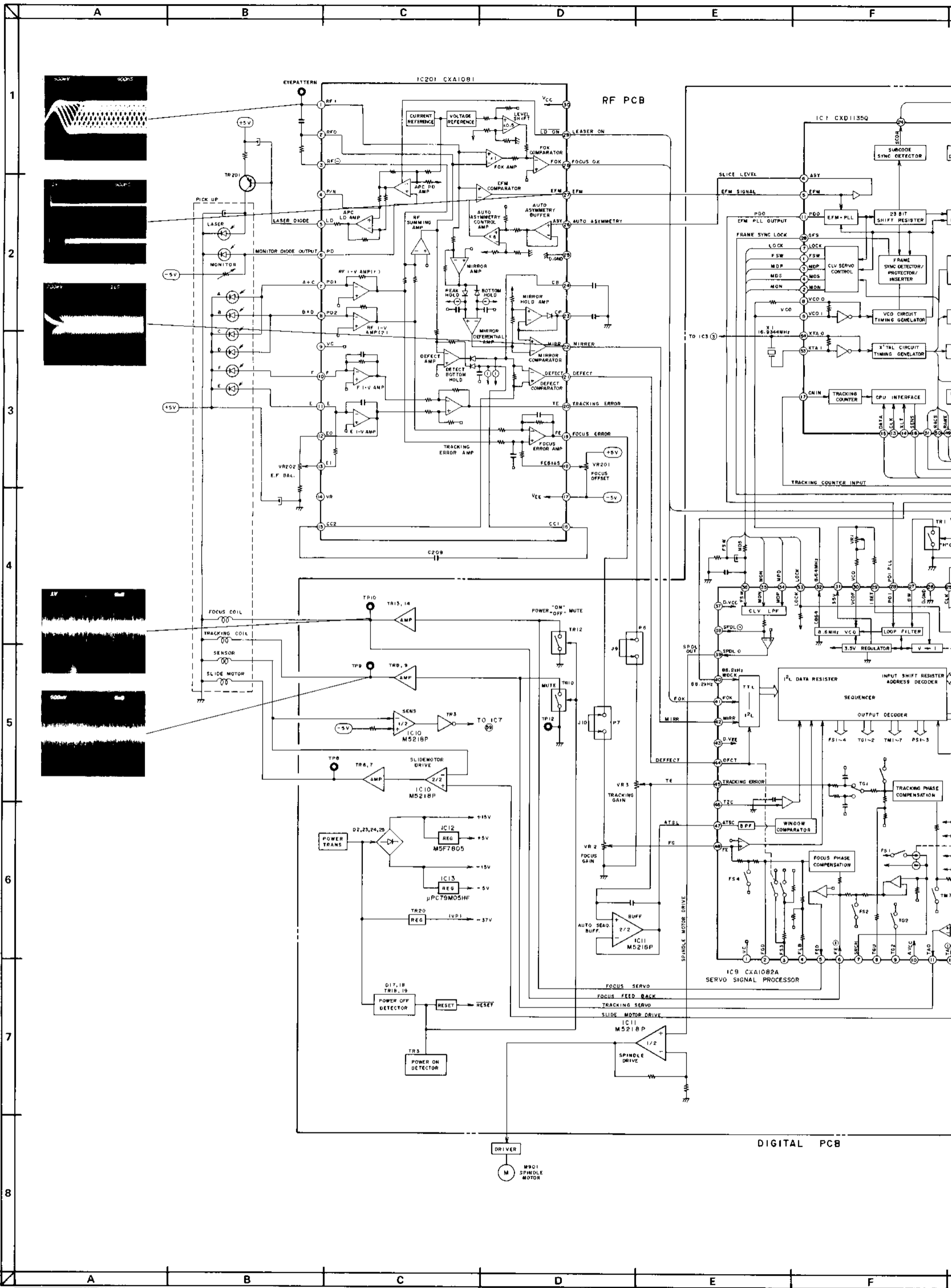

DIGITAL PCB

DRIVER

M901 SPINDLE MOTOR

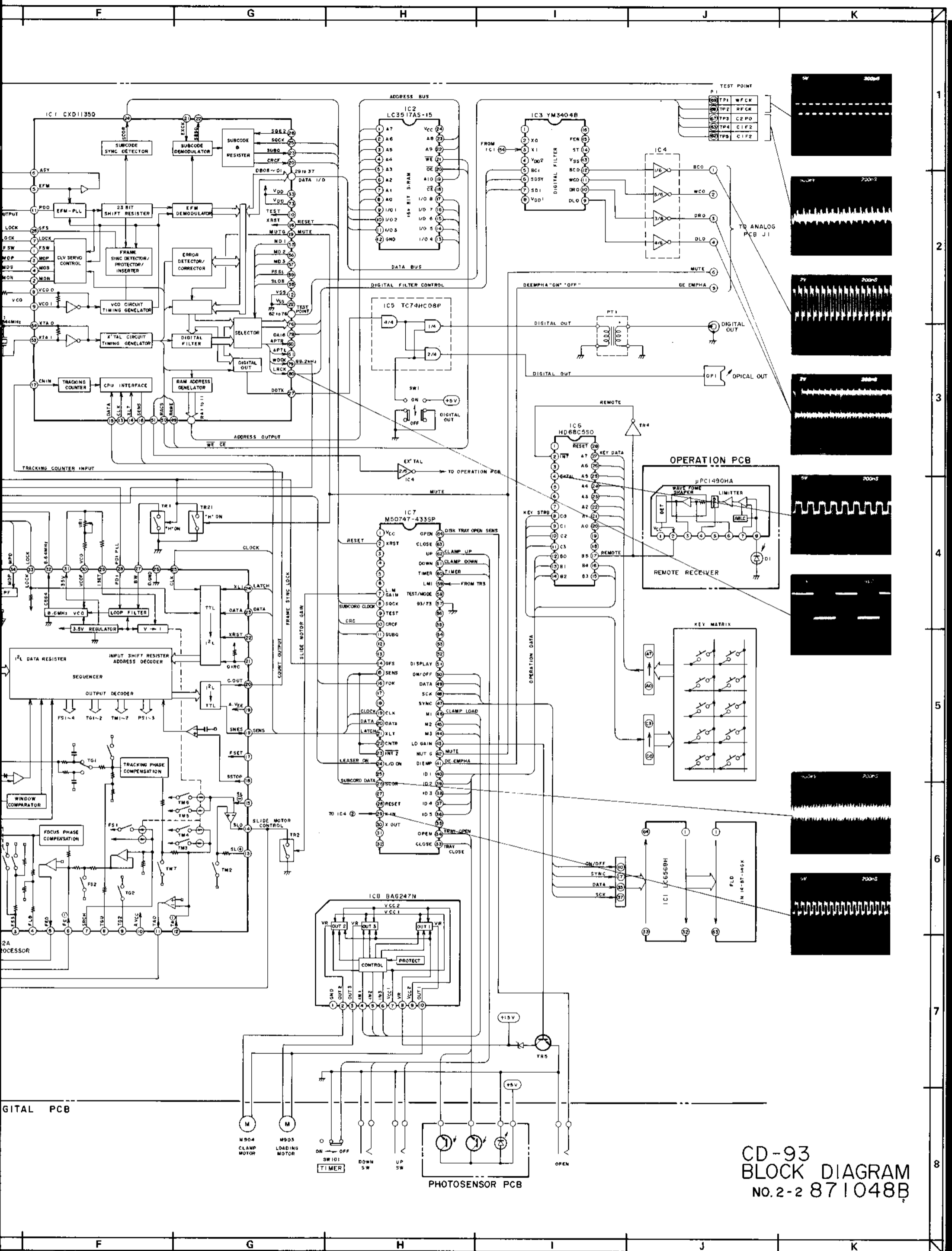

CD-93
BLOCK DIAGRAM
NO.2-2 871048B

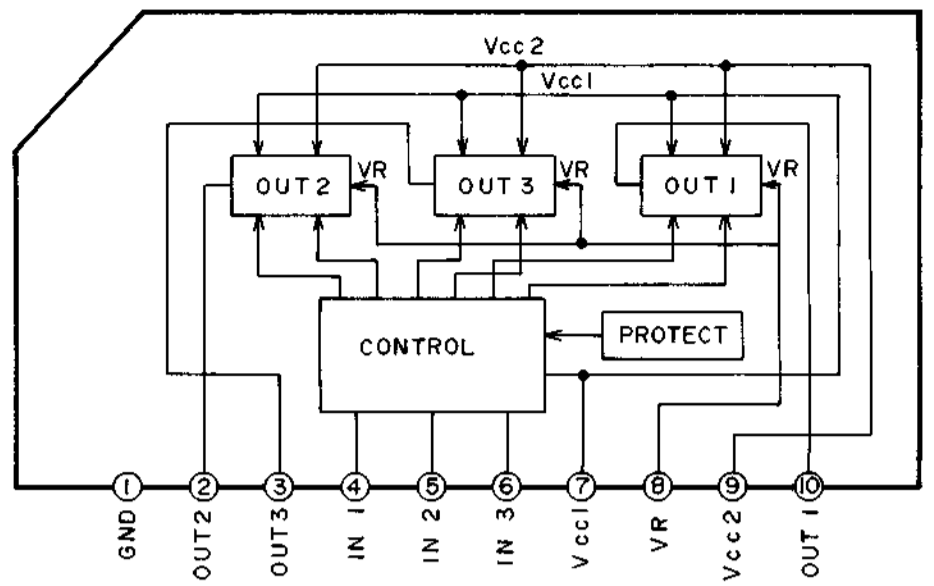

CXD1125Q/CXD1130Q/CXD1135Q

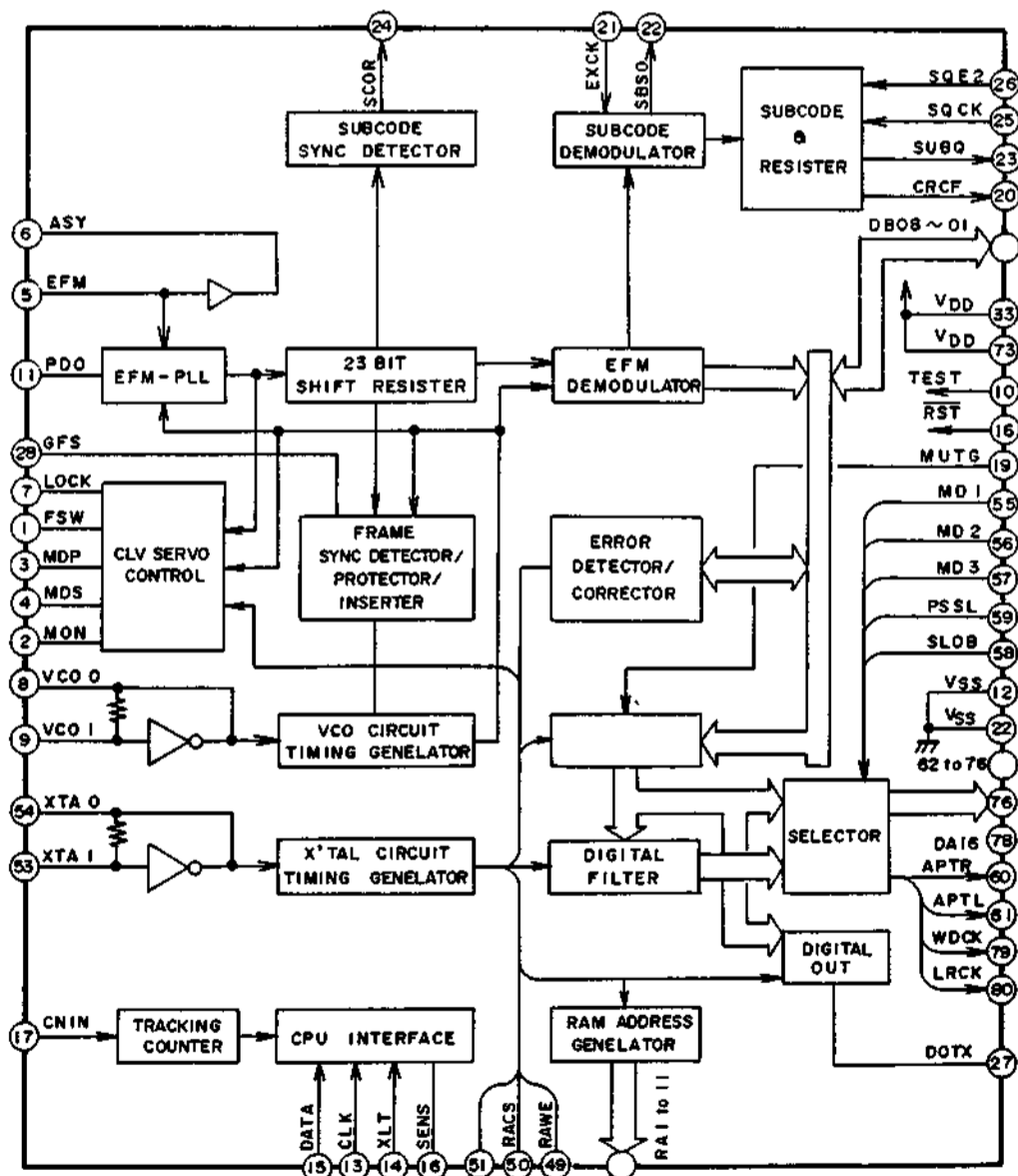

CXD1135Q

No.	Symbol	I/O	Description
1	FSW	O	Spindle motor filter switching control
2	MON	O	Spindle motor ON/OFF control
3	MPD	O	Spindle motor speed and phase control
4	MDS	O	Spindle motor speed control
5	EFM	I	EFM signal input
6	ASY	O	EFM signal slice level control
7	LOCK	O	Slide motor over reach guard signal output
8	VCOO	O	VCO output f=8.6436 MHz
9	VCOI	I	VCO input
10	TEST	I	OV (GND)
11	PDO	O	Phase comp.output
12	VSS	—	GND (OV)
13	CLK	I	Clock signal from CPU
14	XLT	I	Latch signal from CPU
15	DATA	I	Serial data from CPU
16	RST	I	RESET input "L" reset
17	CNIN	I	Tracking pulse input (5V)
18	SENS	O	Output of CPU interface
19	MUTG	I	Mute control signal input
20	CRCF	O	CRC check output of the subcode Q "L" detect error
21	EXCK	I	NOT USE
22	SBSO	O	NOT USE
23	SUBQ	O	Subcode Q output
24	SCOR	O	Subcode sync detection output
25	SQCK	I/O	Clock signal for subcode Q
26	SQEX	I	Select input of CQCK (+5V)
27	DOTX	O	Digital output
28	GFS	O	"H" frame sync lock "L" frame sync unlock
29	DB08	I/O	Data 8 (MSB) Data Bus line for the EXT.RAM (LC3)
30	DB07	I/O	Data 7 Data bus line for the EXT.RAM (LC3)
31	DB06	I/O	Data 6 Data Bus line for the EXT.RAM (LC3)
32	DB05	I/O	Data 5 Data Bus line for the EXT.RAM (LC3)
33	VDD	—	+5V
34	DB04	I/O	Data 4 Data Bus line for the EXT.RAM (LC3)
35	DB03	I/O	Data 3 Data Bus line for the EXT.RAM (LC3)
36	DB02	I/O	Data 2 Data Bus line for the EXT.RAM (LC3)
37	DB01	I/O	Data 1 (LSB) Data Bus line for the EXT.RAM (LC3)
38	RA01	O	ADDR01 (LSB) Address signal output for the EXT
39	RA02	O	ADDR02 Address signal output for the EXT
40	RA03	O	ADDR03 Address signal output for the EXT

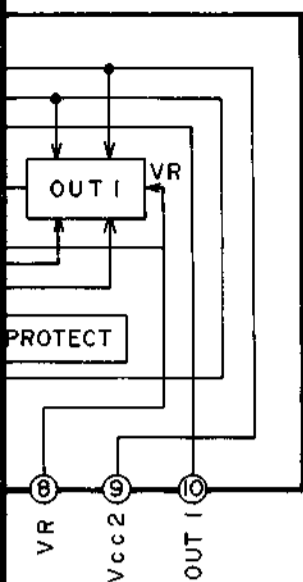

IN PUT			OUT PUT		
IN1	IN2	IN3	OUT1	OUT2	OUT3
L	L	L H	L	L	L
H	L	L	H	L	OPEN
H	L	H	L	H	OPEN
L	H	L	H	OPEN	L
L	H	H	L	OPEN	H
H	H	L H	L	L	L

Description
Motor filter switching control
Motor ON/OFF control
Motor speed and phase control
Motor speed control
Input
Motor slice level control
Motor over reach guard signal output
Output f=8.6436 MHz
Output
Output
Signal from CPU
Signal from CPU
Signal from CPU
Output "L" reset
Pulse input (5V)
CPU interface
Control signal input
Output of the subcode Q "L" detect error
Output
Motor detection output
Signal for subcode Q
Output of CQCK (+5V)
Output
Motor sync lock "L" frame sync unlock
(SB) Data Bus line for the EXT.RAM (LC3517AS-15)
Data bus line for the EXT.RAM (LC3517AS-15)
Data Bus line for the EXT.RAM (LC3517AS-15)
Data Bus line for the EXT.RAM (LC3517AS-15)
Data Bus line for the EXT.RAM (LC3517AS-15)
Data Bus line for the EXT.RAM (LC3517AS-15)
(SB) Data Bus line for the EXT.RAM (LC3517AS-15)
(LSB) Address signal output for the EXT. RAM (LC3517AS-15)
Address signal output for the EXT. RAM (LC3517AS-15)
Address signal output for the EXT. RAM (LC3517AS-15)

No.	Symbol	I/O	Description
41	RA04	O	ADDR04 Address signal output for the EXT. RAM (LC3517AS-15)
42	RA05	O	ADDR05 Address signal output for the EXT. RAM (LC3517AS-15)
43	RA06	O	ADDR06 Address signal output for the EXT. RAM (LC3517AS-15)
44	RA07	O	ADDR07 Address signal output for the EXT. RAM (LC3517AS-15)
45	RA08	O	ADDR08 Address signal output for the EXT. RAM (LC3517AS-15)
46	RA09	O	ADDR09 Address signal output for the EXT. RAM (LC3517AS-15)
47	RA10	O	ADDR10 Address signal output for the EXT. RAM (LC3517AS-15)
48	RA11	O	ADDR11 (MSB) Address signal output for the EXT. RAM (LC3517AS-15)
49	RAWE	O	Write enable signal output "L" active
50	RACS	O	Chip select signal output "L" active
51	C4M	O	1/4X'tal OSC.output (f=4.2336MHz)
52	Vss	—	GND(0V)
53	XTAI	I	X'tal OSC. input (f=16.9344MHz)
54	XTAO	O	X'tal OSC.output (f=16.9344MHz)
55	MD1	I	Mode select input 1 0V (GND)
56	MD2	I	Mode select input 2 0V (GND)
57	MD3	I	Mode select input 3 0V (GND)
58	SLOB	I	0V (GND)
59	PSSL	I	0V (GND)
60	APTR	O	Aperture correction signal output "H" R-channel
61	APTL	O	Aperture correction signal output "H" L-channel
62	C1F1	O	NOT USE
63	C1F2	O	TP-C1F2
64	C2F1	O	NOT USE
65	C2F2	O	NOT USE
66	C2FL	O	TP-CSFL
67	C2P0	O	NOT USE
68	RFCK	O	NOT USE
69	WFCK	O	TP-WFCK
70	PLCK	O	NOT USE
71	UGFS	O	NOT USE
72	GTOP	O	NOT USE
73	VDD	—	+5V
74	RA0V	O	NOT USE
75	4CLR	O	NOT USE
76	C210	O	C210 INV.C210 (Pin 77) f=2.1168MHz
77	C210	O	NOT USE
78	DATA	O	Data output
79	WDCK	O	Word clock output 88.2kHz strobe
80	LRCK	O	NOT USE (L-ch, R-ch clock output)

CXA1082A

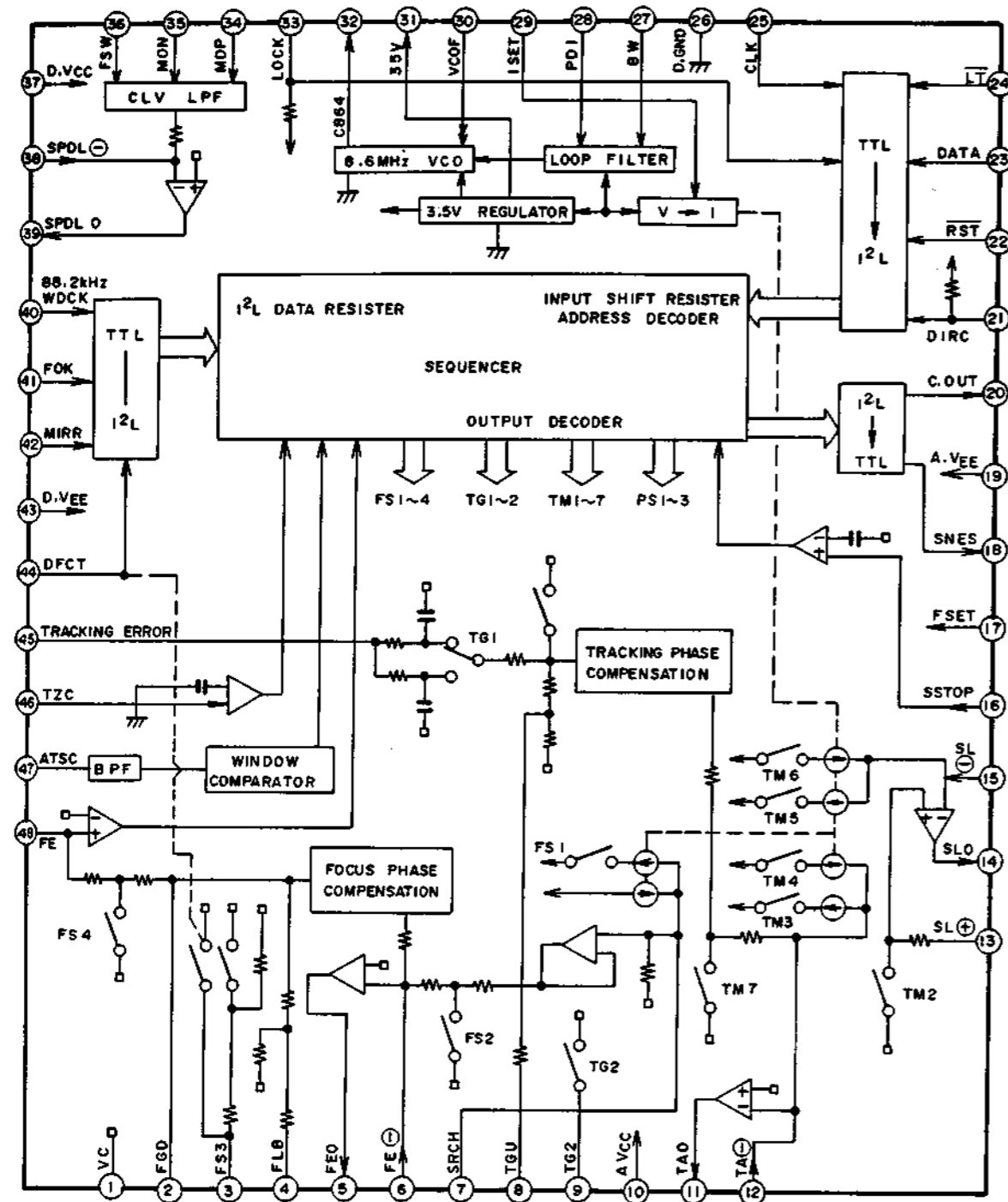

PIN NO.	SYMBOL	I/O	DESCRIPTION
1	VC	—	GND (0V)
2	FGD	—	Connect condenser for Focus servo gain control.
3	FS3	—	Focus servo gain select.
4	FLB	—	Connect condenser for Focus servo correction.
5	FE0	O	Focus drive output.
6	FE ⊖	I	FOCUS AMP. Inverting input.
7	SRCH	—	Connect condenser for Focus search wave.
8	TGU	—	Connect condenser for Tracking gain select.

PIN NO.	SYMBOL	I/O	DESCRIPTION
9	TG2	—	Connect condenser for Tracking gain select.
10	A.Vcc	—	+5V
11	TA0	O	Tracking drive output.
12	TA ⊖	I	Tracking AMP. Inverting input.
13	SL ⊕	I	Slide motor non-inverting input
14	SLO	O	Slide motor drive output.
15	SL ⊖	I	Slide AMP. inverting input.
16	SSTOP	I	Not use (Holed "H" level).
17	FSET	I	Focus, Tracking compensation and CLV. LPF set up.
18	SENS	O	FZC. AS. TZC. SSTOP and $\overline{\text{BUSY}}$ output.
19	A. VEE	—	-5V.
20	C.OUT	O	Track count signal output.
21	DIRC	—	Not used
22	$\overline{\text{RST}}$	I	RESET Input.
23	DATA	I	Data signal input from CPU.
24	$\overline{\text{LT}}$	I	Lutch signal input from CPU.
25	CLK	I	Clock signal input from CPU.
26	D.GND	—	GND (0V).
27	BW	I	Connect condenser for Loop filter.
28	PDI	I	PDO signal from IC3 CXD1135Q (Pin 11).
29	ISET	I	Focus search, Track jump and slide kick current input.
30	VCOF	I	Connect register for VCO frequency.
31	3.5V	O	+3.5V REG. output.
32	C864	O	8.64 MHz VCO output.
33	LOCK	I	LOCK signal from IC3 CXD1135Q (Pin 7)
34	MDP	I	MDP signal from IC3 CXD1135 (Pin 3)
35	MON	I	MON signal from IC3 CXD1135 (Pin 2)
36	FSW	I	Connect condenser for CLV servo error signal LPF.
37	DVcc	—	+5V
38	SPDL ⊖	I	Spindle drive AMP. inverting input.
39	SPDLO	I	Spindle drive output.
40	WDCK	I	Auto sequence clock signal input (88.2 kHz)
41	FOK	I	Focus OK signal input.
42	MIRR	I	MIRR signal input.
43	D.VEE	—	-5V
44	DFCT	I	Defect signal input "H" active.
45	TE	I	Tracking error signal input.
46	TZC	I	Tracking zero cross comparator input.
47	ATSC	I	ATSC detect window comparator input.
48	FE	I	Focus error signal input.

LB1240

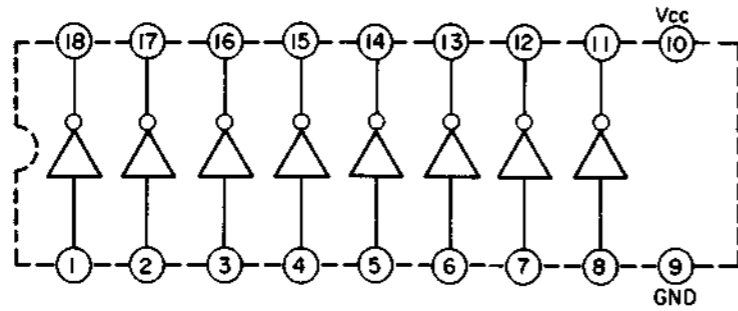

LC3517AS-15

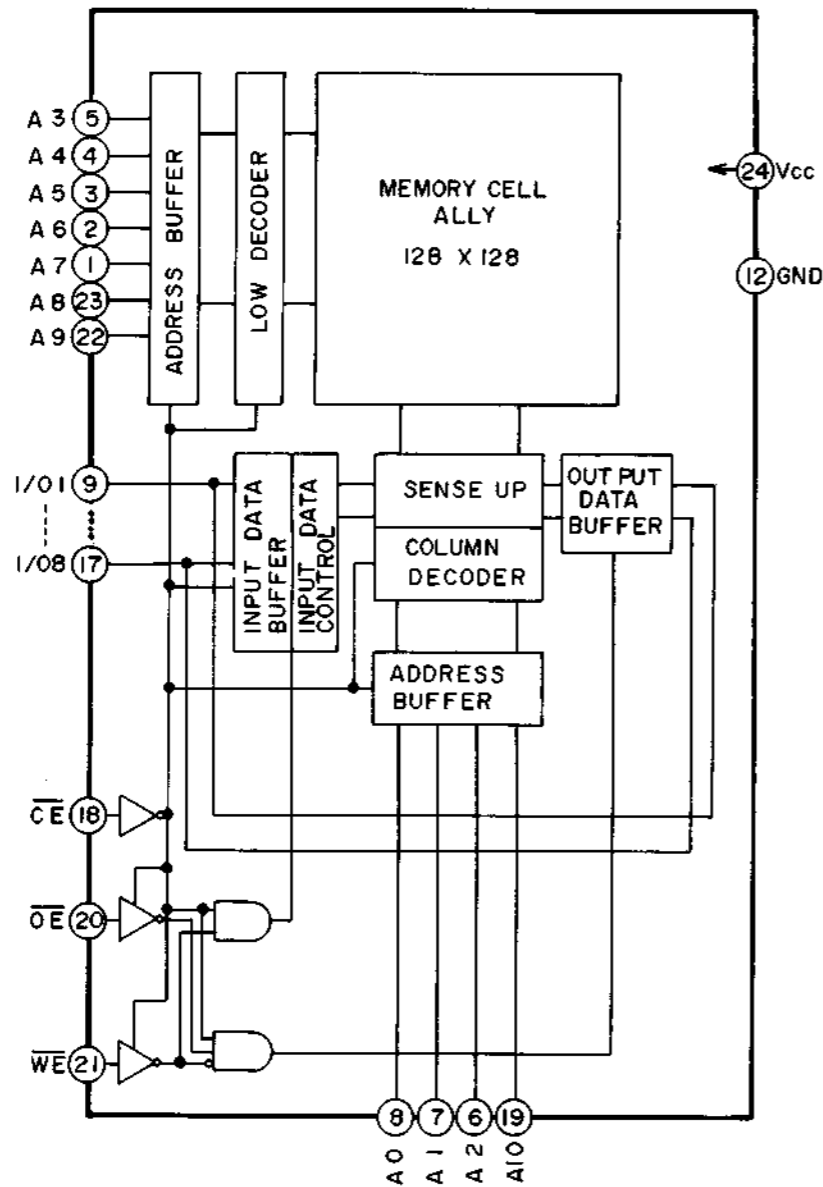

IC M50747-433SP

PIN NO.	SYMBOL	I/O	FUNCTION	
1	V _{cc}	—	+5V	
2	RST	O	Reset control for external LSI.	
3	—	—	Not used	
4	—	—	Not used	
5	—	—	Not used	
6	—	—	Not used	
7	L.M GAIN	O	Speed control when sled moving inward direction, "L" = Farst	
8	SQCK	O	Reading clock output for sub cord data.	
9	TEST	O	Test terminal	
10	CRCF	I	Error check data input of sub cord.	
11	SUBQ	I	Sub cord data input	
12	—	—	Not used	
13	—	—	Not used	
14	GFS	I	PLL Lock Detection input	H: PLL Lock
15	SENS	I	Auto sequence end detection input	H: Auto sequence end
16	FOK	—	Focus Lock Detection input	H: Focus Lock
17	—	—	Not used	
18	—	—	Not used	
19	CLK	O	Clock output for external LSI.	
20	DATA	O	Data output for external LSI	8 bit serial data.
21	LT	O	Latch output for external LSI.	
22	CNTR	I	For cut the 1/256 pulse of track, when sled moving largely.	
23	INT ₂	—	Not used	
24	L/D ON	O	Laser diode ON/OFF control.	
25	—	—	Not used	
26	SCOR	I	Input of sub cord sync. S0 + S1.	
27	CNV _{ss}	—	GND	
28	RESET	I	Reset input	
29	X IN	I	Clock input	8.4672 MHz
30	X OUT	O	Not used	
31	—	—	Not used	
32	V _{ss}	—	GND	
33	PH2	O	Tray Position Detect (1) input	
34	PH1	O	Tray Position Detect (2) input	
35	—	—	Not used	
36	ID5	I	} Key Data input from Input expander IC HD6805SO	
37	ID4	I		
38	ID3	I		
39	ID2	I		

PIN NO.	SYMBOL	I/O	FUNCTION	
40	ID1	I	Key Data input from Input expander IC HD6805SO	
41	DE EMP	O	De-emphasis ON/OFF control output	
42	MUTG.	O	Mute ON/OFF control output	
43	L.D GAIN	O	Loading motor speed control output (L = Normal speed, H: Low speed)	
44	M3	O	} Loading and clamp motor control logic output for IC BA6247N	
45	M2	O		
46	M1	O		
47	SYNC	O	Data (8 bit × 32) end ID output	} Display data transfer for Display MI-CON LC 6568H-3425
48	SCK	O	Display data clock	
49	DATA	O	Display data (8 bit × 32) serial data	
50	DISPLAY ON/OFF	O	Display ON/OFF control	
51	—	—	Not used	
52	—	—	Not used	
53	—	—	Not used	
54	—	—	Not used	
55	—	—	Not used	
56	—	—	Not used	
57	—	—	Not used	
58	TEST MODE	I	Test mode select input.	L: Test mode select.
59	L.M.I	I	Linear motor moving direction input	H: When moving to inward.
60	TIMER	I	Timer start select input	H: Timer start
61	DOWN	I	Clamper down detection input	L: Down
62	UP	I	Clamper up detection input	L: Up
63	—	—	Not used	
64	OPEN	I	Tray up detection input	L: Up

PCM-56PJ 16 BIT D/A CONVERTER

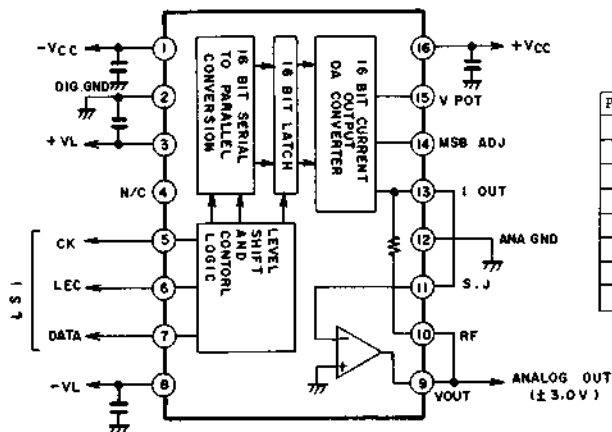

PIN NO	FUNCTION	PIN NO	FUNCTION
1	-Vcc ANALOG ⊕ B	16	+Vcc ANALOG ⊕ B
2	DIG GND DIGITAL GND	15	VPOT POTENTIAL METER
3	+VL LOGIC ⊕ B	14	MSB ADJ MSB ADJUSTMENT
4	N/C NO CONNECTION	13	Tout I OUT
5	CK CLOCK IN	12	ANA GND ANALOG GND
6	LEC LATCH ENABLE CONTROL IN	11	S J SUMMING JUNCTION
7	DATA DATA IN	10	RF FB REGISTER
8	-VL LOGIC ⊕ B	9	Vout V OUT

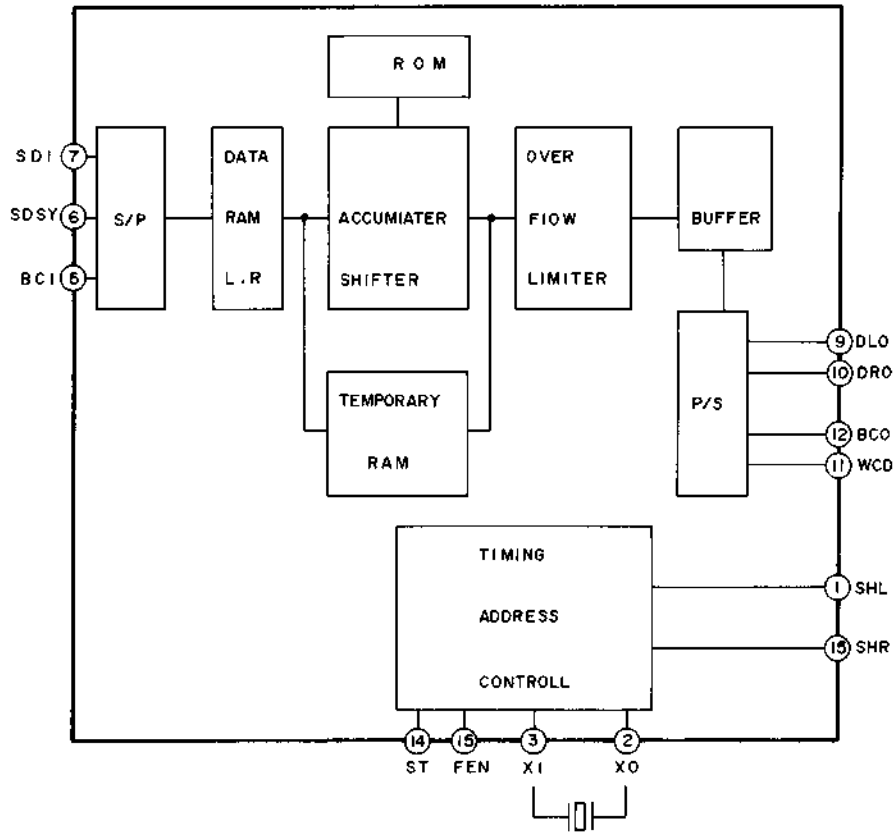

Pin No.	Symbol	I/O	Function
1	SHL	O	1 DAC (ST="L") use: L channel diglitcher signal output. 2 DAC (ST="H") use: L/R channels diglitcher signal output.
2	XO	O	Terminal for X'tal when using the internal clock osc.
3	XI	I	Terminal for X'tal when using the internal clock osc or Input terminal of external clock.
4	Vdd2		Power Supply (+5V) for X'tal OSC and Deglitcher.
5	BCI	I	Input the bit clock of the Input data.
6	SDSY	I	Difference Between L and R channel and provided input timing of data.
7	SDI	I	Data input terminal.
8	Vdd1		Power Supply (+5V) for digital signal.
9	DLO	O	1 DAC (ST="L") use: L, R channel data output 2 DAC (ST="H") use: L channel data output.
10	DRO	O	R channel data output.
11	WCO	O	Word clock of output data DLO and DRO.
12	BCO	O	Output terminal for bit clock of output data and system clock of SPC2,3.
13	Vss		Ground terminal
14	ST	I	Select control of 1DAC or 2DAC ("L"=1DAC, "H"=2DAC).
15	FEN	I	Select control of system clock ("L"=196fs, "H"=192fs)
16	SHR	O	Deglitcher signal of R channel when 1DAC is selected.