

AKAI SERVICE MANUAL

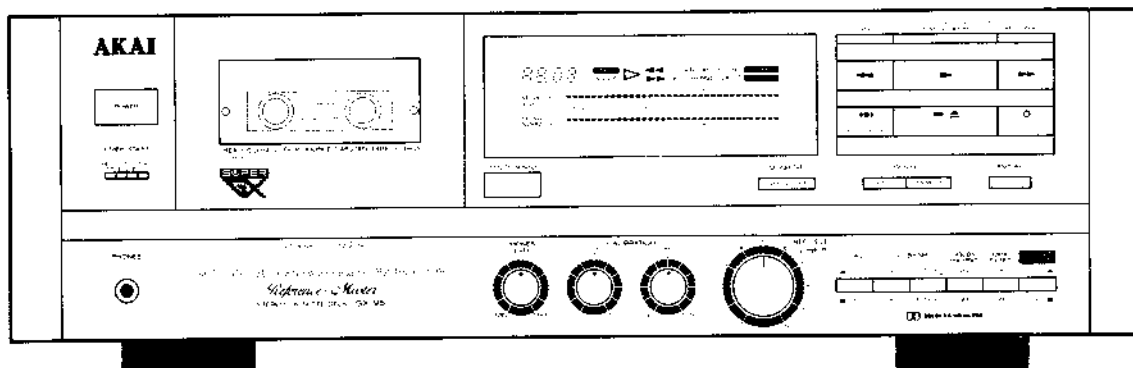

MODEL GX-95

STEREO CASSETTE DECK

MODEL **GX-75**

MODEL **GX-95**

SPECIFICATIONS

Track System	GX-95 4 track 2 channel stereo	GX-75 4 track 2 channel stereo
Heads	LC-OFC Super GX head for recording×1 LC-OFC Super GX head for playback×1 Erase head×1	LC-OFC Super GX head for recording×1 LC-OFC Super GX head for playback×1 Erase head×1
Motors	FG Servo D.D. Motor for capstan drive×1 DC motor for reel drive×1 DC motor for cam drive & tape eject/ loading×1	FG Servo D.D. Motor for capstan drive×1 DC motor for reel drive×1 DC motor for cam drive & tape eject/ loading×1
Wow & Flutter	0.025% (WRMS), 0.04% (DIN)	0.025% (WRMS), 0.04% (DIN)
S/N (Metal)	59dB (Measured via tape with peak recording level) Dolby B type NR switch ON: Improves up to 5dB at 1kHz, 10dB above 5kHz Dolby C type NR switch ON: Improves up to 15dB at 500Hz, 20dB at 1kHz to 10kHz	59dB (Measured via tape with peak recording level) Dolby B type NR switch ON: Improves up to 5dB at 1kHz, 10dB above 5kHz Dolby C type NR switch ON: Improves up to 15dB at 500Hz, 20dB at 1kHz to 10kHz
T.H.D.	less than 0.6% (Metal)	less than 0.6% (Metal)
Frequency response	Normal..... 20Hz to 19,000Hz ± 3dB CrO ₂ 20Hz to 20,000Hz ± 3dB Metal..... 20Hz to 21,000Hz ± 3dB	20Hz to 19,000Hz ± 3dB 20Hz to 20,000Hz ± 3dB 20Hz to 21,000Hz ± 3dB
Input sensitivity/Impedance		
Line	70mV/47kohms	70mV/47kohms
CD/DAT direct in	240mV/47kohms	240mV/47kohms
Output Level/Impedance		
Line	388mV/150 ohms	388mV/150 ohms
Headphones	1.3mW (8 ohms)	1.3mW (8 ohms)
Power requirements	220V, 50Hz for Europe except UK 240V, 50Hz for UK and Australia 110V/120V/220V/240V, 50Hz/60Hz convertible for other countries	220V, 50Hz
Dimensions	460(W)×154(H)×350(D)mm	425(W)×154(H)×350(D)mm
Weight	10.2kg	9.2kg
Standard accessories		
Connection cords	RCA pin cord×2	RCA pin cord×2
Remote Control Unit	×1	Operator's manual ×1
Dry Batteries	R6 (AA) size×2	
Operator's manual	×1	

* For improvement purposes, specifications and design are subject to change without notice.

★ SAFETY INSTRUCTIONS

PRECAUTIONS DURING SERVICING

1. Parts identified by the †(*) symbol parts are critical for safety. Replace only with parts number specified.
2. In addition to safety, other parts and assemblies are specified for conformance with such regulations as those applying to spurious radiation. These must also be replaced only with specified replacements.
Examples: RF converters, tuner units, antenna selector switches, RF cables, noise blocking capacitors, noise blocking filters, etc.
3. Use specified internal wiring. Note especially:
 - 1) Wires covered with PVC tubing
 - 2) Double insulated wires
 - 3) High voltage leads
4. Use specified insulating materials for hazardous live parts. Note especially:
 - 1) Insulation Tape
 - 2) PVC tubing
 - 3) Spacers (Insulating Barriers)
 - 4) Insulation sheets for transistors
 - 5) Plastic screws for fixing microswitch (especially in turntable)
5. When replacing AC primary side components (transformers, power cords, noise blocking capacitors, etc.), wrap ends of wires securely about the terminals before soldering.

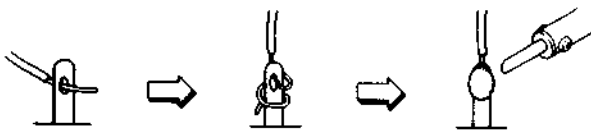

6. Observe that wires do not contact heat producing parts (heatsinks, oxide metal film resistors, fusible resistors, etc.).

7. Check that replaced wires do not contact sharp edged or pointed parts.
8. Also check areas surrounding repaired locations.
9. Use care that foreign objects (screws, solder droplets, etc.) do not remain inside the set.

SAFETY CHECK AFTER SERVICING

After servicing, make measurements of leakage-current or resistance in order to determine that exposed parts are acceptably insulated from the supply circuit.

The leakage-current measurement should be done between accessible metal parts (such as chassis, ground terminal, microphone jacks, signal-input/output connectors, etc.) and the earth ground through a resistor of 1500 ohms paralleled with a 0.15 μ F capacitor, under the unit's normal working conditions. The leakage-current should be less than 0.5 mA rms AC.

The resistance measurement should be done between accessible exposed metal parts and power cord plug prongs with the power switch (if included) "ON". The resistance should be more than 2.2 Mohms.

★ INFORMATION

SYMBOLS FOR PRIMARY DESTINATION

Alphabet indicates the destination of the units as listed below.

Symbols	Principal Destinations
A	USA
B	UK
C	Canada
E	Europe (except UK)
J	Japan
S	Australia
V	W. Germany only
U	Universal Area
Y*	Custom version

VOLTAGE CONVERSION

(U Model only)

Before connecting the power cord. Set the VOLTAGE SELECTOR located on the rear panel with a screwdriver so that the correct voltage is indicated.

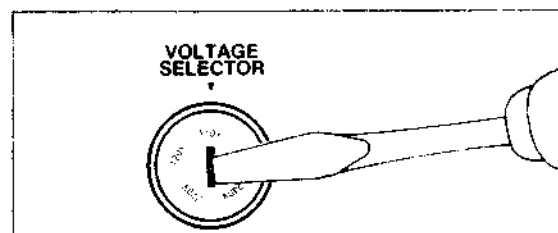

I. CONTROLS

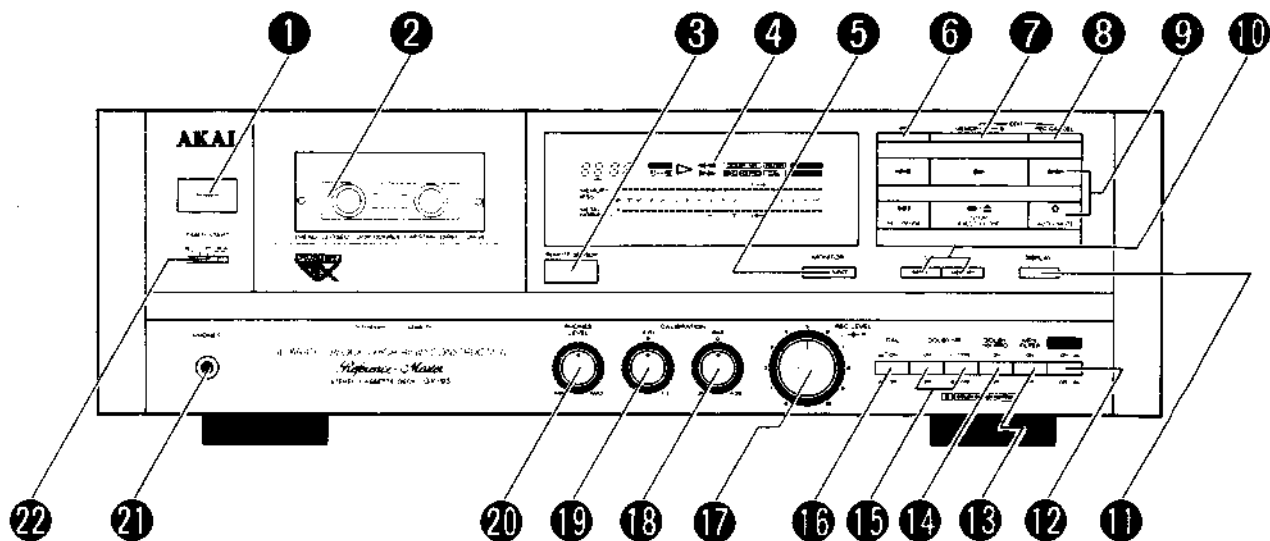

- 1 POWER button**
To turn the power on and off.
- 2 Cassette Lid and Holder**
Load a cassette tape here. To open and close the holder, press the button.
- 3 REMOTE SENSOR Window**
For reception of the remote control signal from the provided RC-G95 remote control unit. Keep away from strong light and direct sunlight as this will interfere with the remote control function.
- 4 FL Display**
Tells you what the cassette deck is doing.
- 5 MONITOR Button (TAPE/SOURCE)**
To select between TAPE and SOURCE monitor modes. This button is incorporated with an auto monitor system.
- 6 IPSS (Instant Program Searching System) Button**
To turn the IPSS on and off.
- 7 MEMORY A→B Button**
To memorize the repeat playback intervals for 2-point repeat playback or the erase intervals for the spot erase function.
- 8 REC CANCEL Button**
To erase the recorded program during recording or to cancel the memorized intervals for the spot erase function.
- 9 Operation Buttons (: Rewind button, : Play button, : Fast forward button, : REC PAUSE button, / : STOP EJECT/ CLOSE button, : AUTO MUTE button)**
To open and close the cassette holder, to start and stop recording and playback, to wind the tape and to engage the auto mute mode.
- 10 COUNTER RESET and MEMORY Buttons**
To reset the digital tape counter to the "00 min: 00 sec" position and to turn the memory system on and off.
- 11 DISPLAY Button**
To turn the FL display on and off.
- 12 CD/DAT DIRECT IN Switch (ON/ OFF)**
To select between input sources connected to the LINE IN or CD/DAT DIRECT IN jacks. For normal recording, set this button to .
- 13 MPX FILTER Switch (ON/ OFF)**
To turn the multiplex filter on and off.
- 14 DOLBY HX PRO Switch (ON/ OFF)**
To turn the Dolby HX PRO system on and off. The Dolby HX PRO system will affect recording only when the button is set to . Otherwise it is automatically defeated during playback.
- 15 DOLBY NR ON/OFF Switch and C-TYPE/B-TYPE Select Switch**
To turn the DOLBY NR system on and off and to select between B type or C type noise reduction for recording and playback purposes.
- 16 CAL (Calibration) Switch (ON/ OFF)**
To turn the recording calibration system on and off.
- 17 REC LEVEL Controls (LEFT → RIGHT)**
To set the recording input level. The outside knob is for left channel level control and the inside knob is for right channel level control. For normal stereo recording the red lines should be set to the same position.
- 18 BIAS CALIBRATION Control**
To adjust the recording bias current during recording calibration. The bias adjustment range is between -20% and +20% of the proper bias current for Normal, CrO₂ and Metal position tapes. Normally set the control to the center click "D" position.
- 19 LEVEL CALIBRATION Control**
To adjust the recording sensitivity level during recording calibration. The recording sensitivity level adjustment range is between -3% and +3% of the proper recording sensitivity level for Normal, CrO₂ and Metal position tapes. Normally set the control to the center click "0" position.
- 20 PHONES LEVEL Control**
To adjust the output level of the PHONES jack.
- 21 PHONES Jack**
For headphone connection.
- 22 TIMER START Switch (REC/OFF/PLAY)**
To select operation of the timer start function when the power is turned on.

II. DISASSEMBLY

In case of trouble, etc, necessitating dismantling, please dismantle in the order shown in the photographs. Reassemble in reverse order.

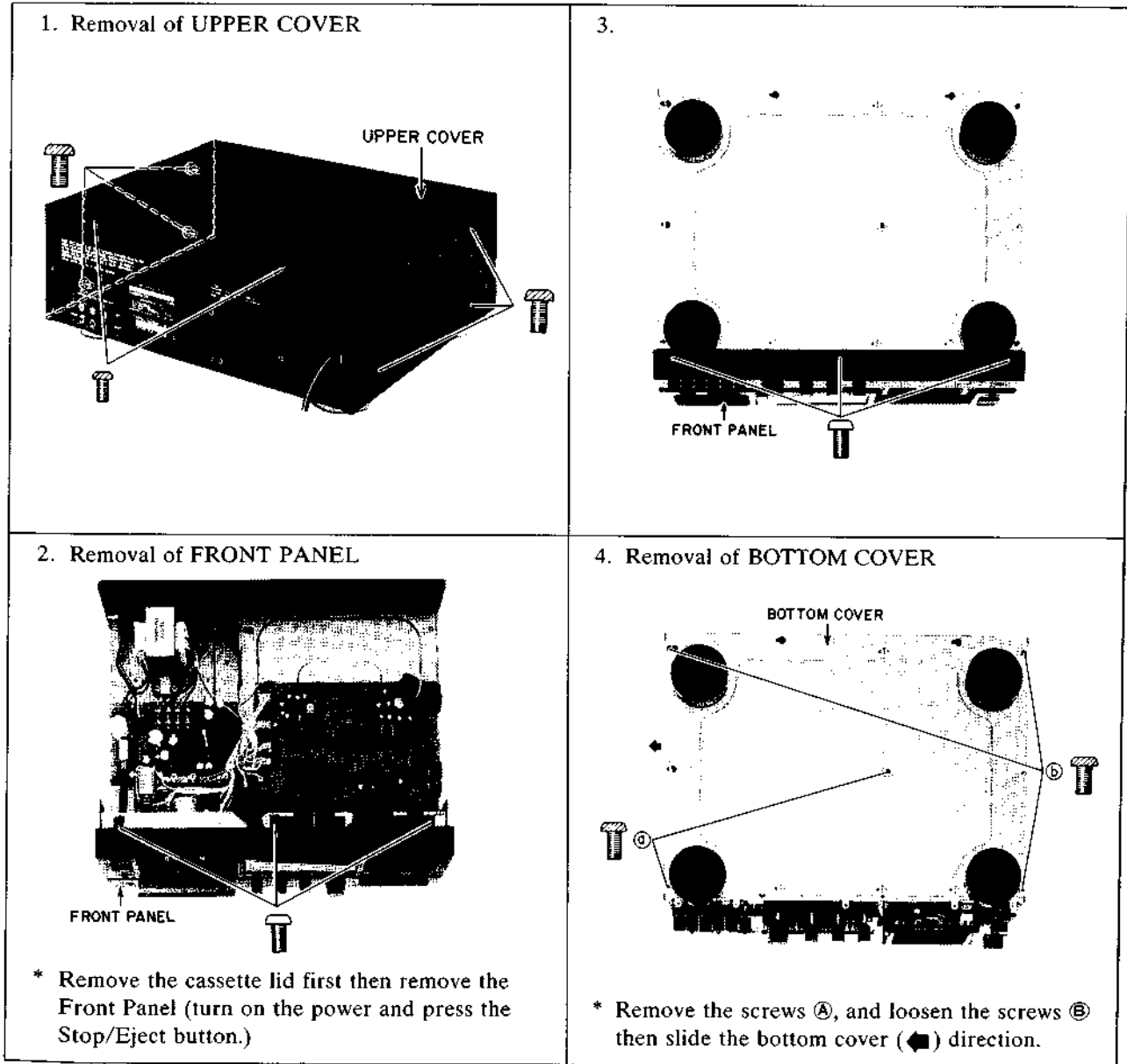

* Photographs employed here are of model GX-75.

III. PRINCIPAL PARTS LOCATION

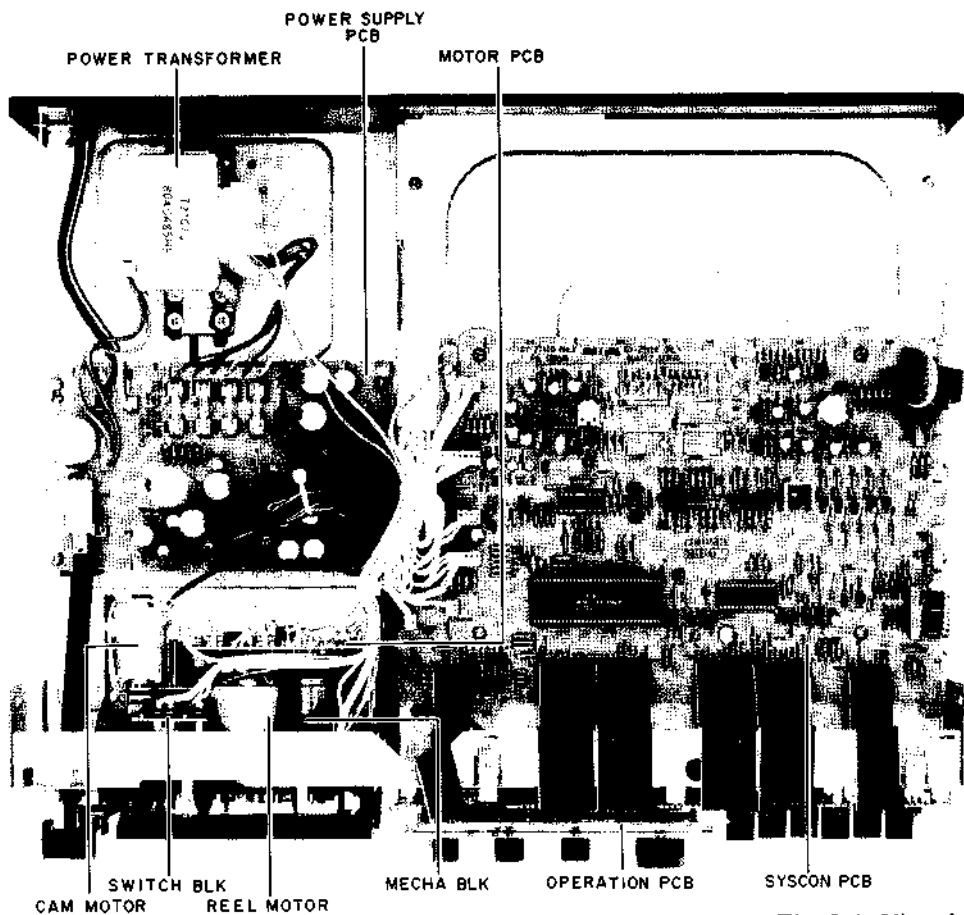

Fig. 3-1 View from upper side

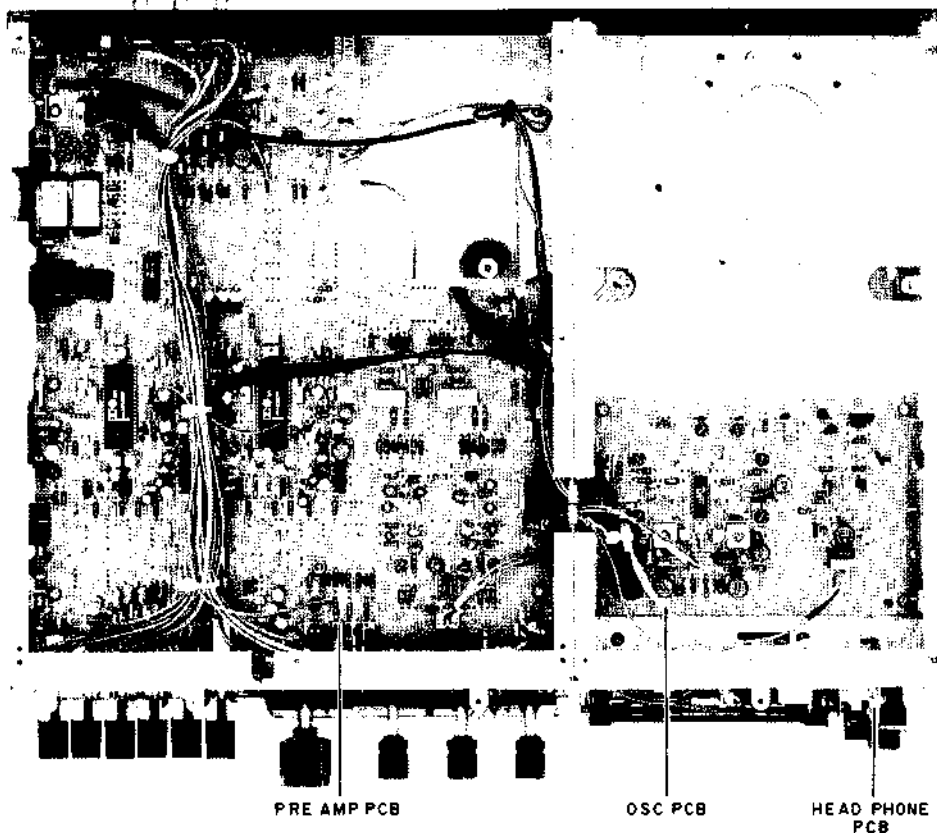

Fig. 3-2 View from bottom side

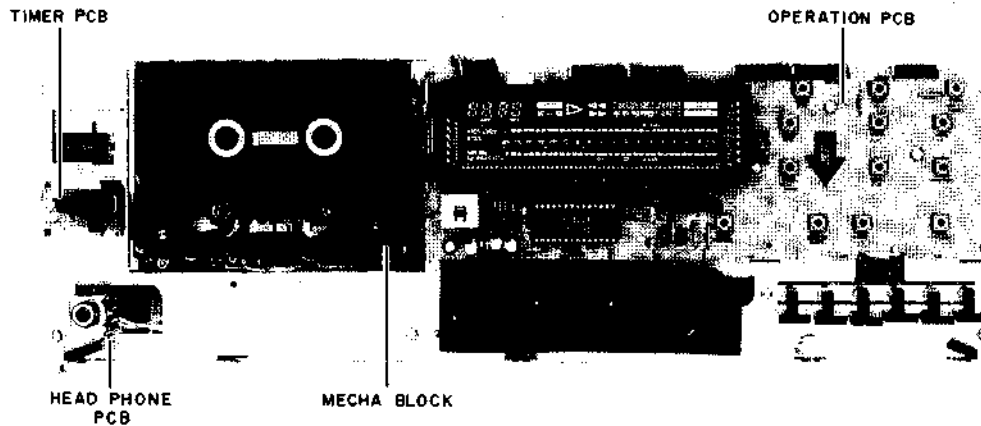

Fig. 3-3 View from bottom side

IV. DISASSEMBLY AND REASSEMBLY OF THE MECHANISM

4-1. REMOVING THE LID CASE AND LID DECORATION

- 1) Turn the power on and press the STOP/EJECT button. Remove the lid panel when the lid is in the eject position. Press the STOP/EJECT button a second time to close the lid. Turn the power off.
- 2) Remove the upper cover, front panel and bottom cover.
- 3) Turn the power on again and press the STOP/EJECT button. Turn the power off again with the lid in the eject position.
- 4) While pressing down on both sides of the lower part of the lid case with your hands, disengage the lid case from the right-hand lid collar and lid arm. Next, disengage the lid case from the left-hand lid collar, lid arm and oil clutch. (See Fig. 4-1.)
- 5) Next, while pressing up slightly on the decoration stopper on the upper right and left sides, move the lid decoration forward and down, disengaging it from the holders and guide shafts on the bottom left and right. (See Fig. 5-2.)
- 6) To reassemble, perform the above steps in reverse order.

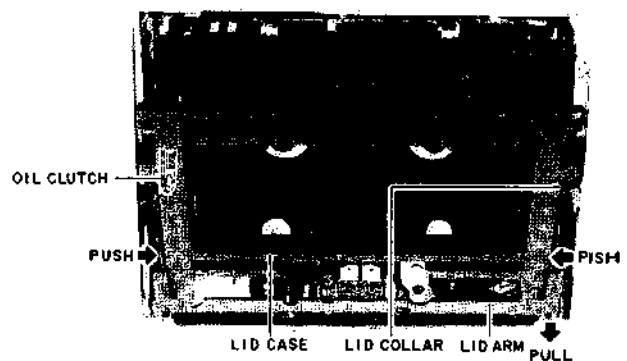

Fig. 4-1

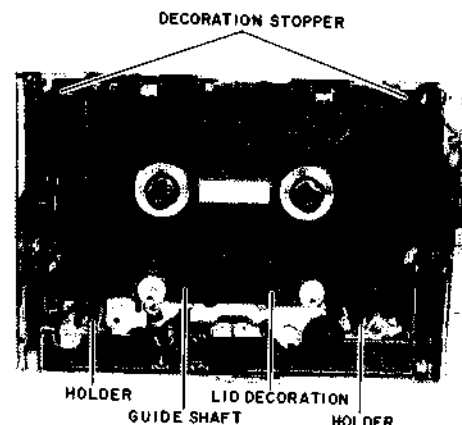

Fig. 4-2

4-2. REMOVING THE MECHANISM BLOCK

- 1) Remove connector J101 from the PRE AMP PCB and the J501 and J551 from the OSC PCB. Next, remove mechanism block securing screws ③ and ⑥. (See Fig. 4-3.)
- 2) Remove the six connectors P1—P6 from the SYS-CON PCB. Remove mechanism block securing screws ④ and ⑤. (See Fig. 4-4.)
- 3) Finally, lift the mechanism block upward to remove it.
- 4) To reassemble, perform the above steps in reverse order.

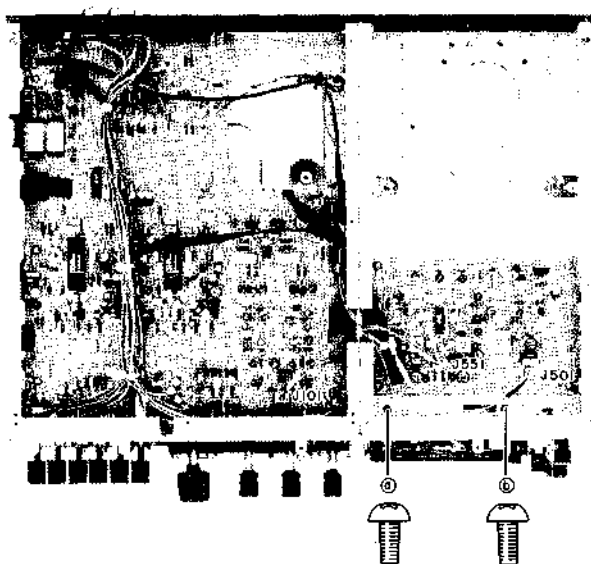

Fig. 4-3

4-3. REMOVING THE MOTOR BLOCK

- 1) First remove the lid case and lid decoration, then take the mechanism block out of the main unit.
- 2) Remove the MOTOR BLOCK securing screw from the left side panel of the mechanism block. (See Fig. 4-5.)
- 3) Remove motor block securing screws ②, ⑤ and ⑥ from the mechanism block front side. Remove the motor block from the mechanism block. (See Fig. 4-6.)
- 4) To reassemble, perform the above steps in reverse order.

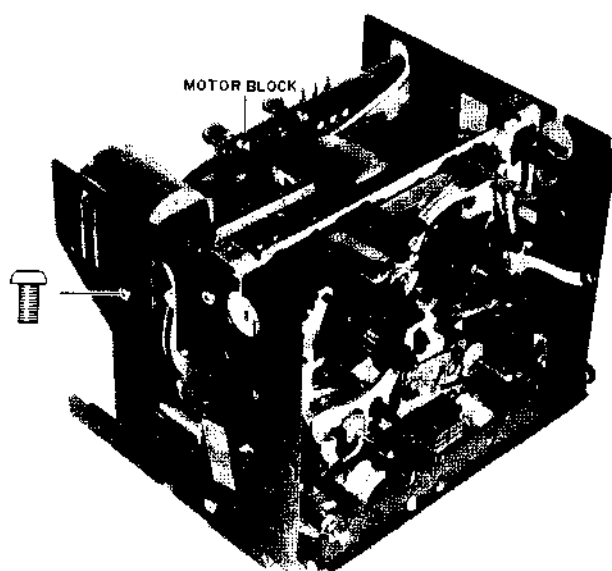

Fig. 4-5

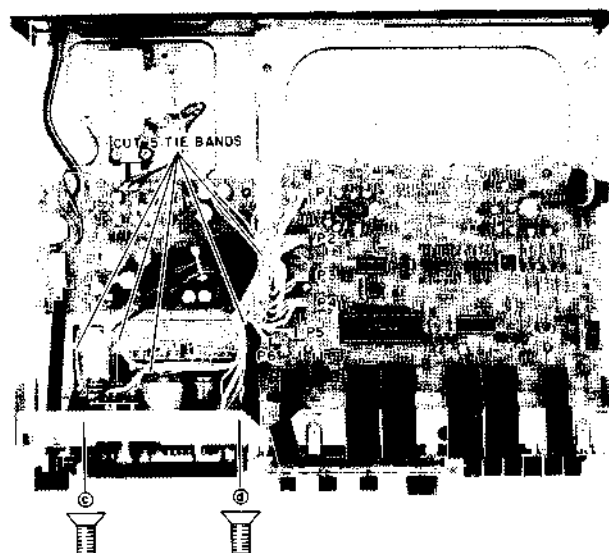

Fig. 4-4

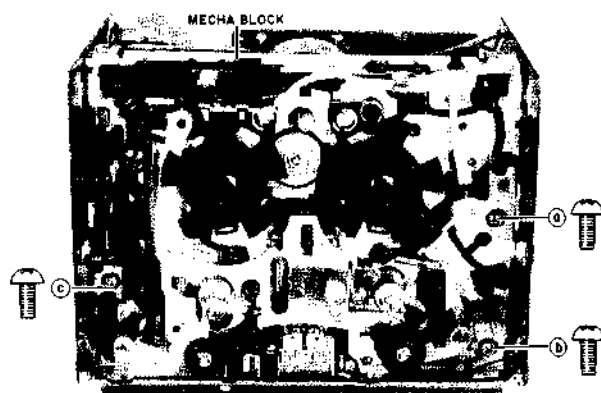

Fig. 4-6

4-4. REMOVING THE CAM MOTOR AND CAM BELT

- 1) Remove the motor block from the mechanism block. (See section 4-3, "Removing the motor block.")
- 2) Disconnect the two cam motor lead wires.
- 3) Remove cam motor base screws (a) and (b) from the motor block. (See Fig. 4-7.)
- 4) Remove the cam belt and operation pulley from the cam motor block which has just been removed.
- 5) Remove cam motor securing screws (c) and (d). (See Fig. 4-8.)
- 6) To reassemble, perform the above steps in reverse order.

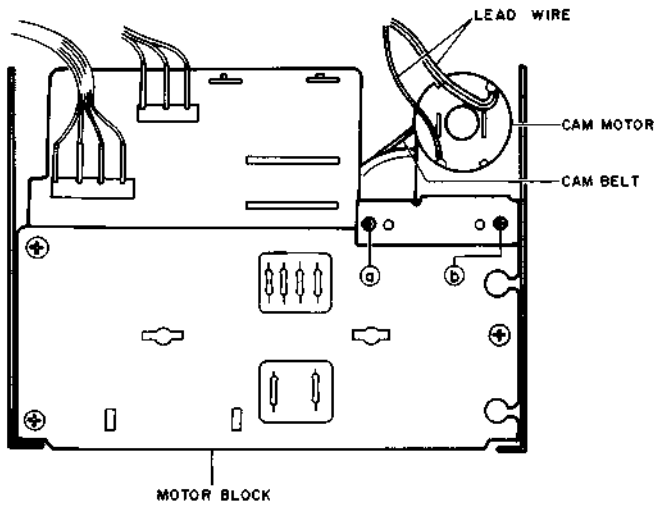

Fig.4-7

4-5. REPLACING THE HALL ELEMENT

- 1) Remove the motor block from the mechanism block. (See section 4-3, "Removing the motor block.")
- 2) Remove motor PCB block securing screws (a), (b) and (c) and take out the motor PCB block. (See Fig. 4-9.)
- 3) Remove the solder from the Hall element. Remove the Hall element from the motor circuit board.
- 4) When attaching a replacement, connect the protruding portion of the Hall element to the circuit board. (See Fig. 4-10.)
- 5) To reassemble, perform the above steps in reverse order.

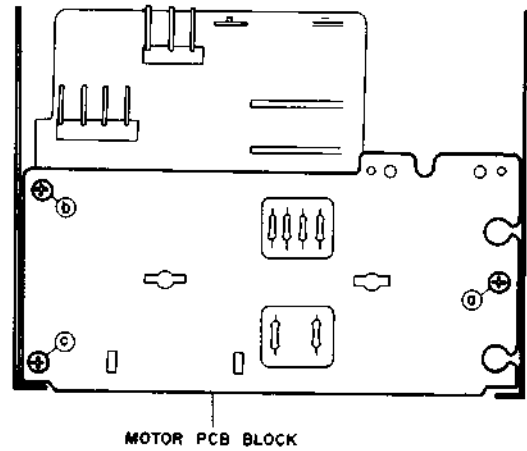

Fig. 4-9

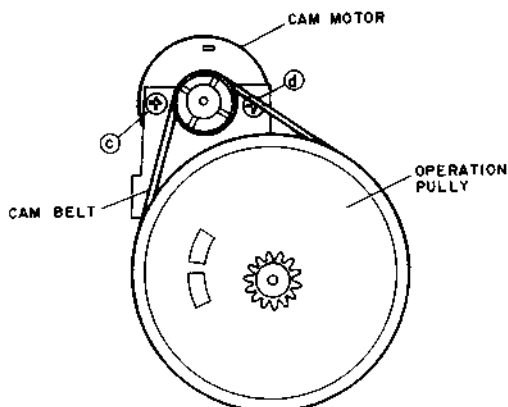

Fig. 4-8

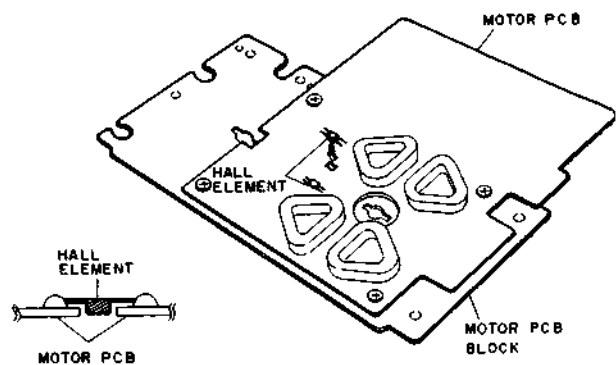

Fig. 4-10

4-6. REMOVING THE CAM WHEEL AND POSITION POTENTIOMETER

- 1) Remove the motor block from the mechanism block. (See section 4-3, "Removing the motor block.") Also remove the motor PCB, the capstan belt and the fly-wheel.
- 2) Remove the stopper ring from the capstan holder. Pull off the cam wheel. (See Fig. 4-11.)
- 3) Remove capstan holder securing screws (A), (B), (C) and (D). Remove the capstan holder. (See Fig. 4-12.)
- 4) Remove the potention gear. Unscrew the position potentiometer securing nut. (See Fig. 4-13.)
- 5) To reassemble, follow the directions in section 4-7, "Reassembling the cam wheel and position potentiometer," below.

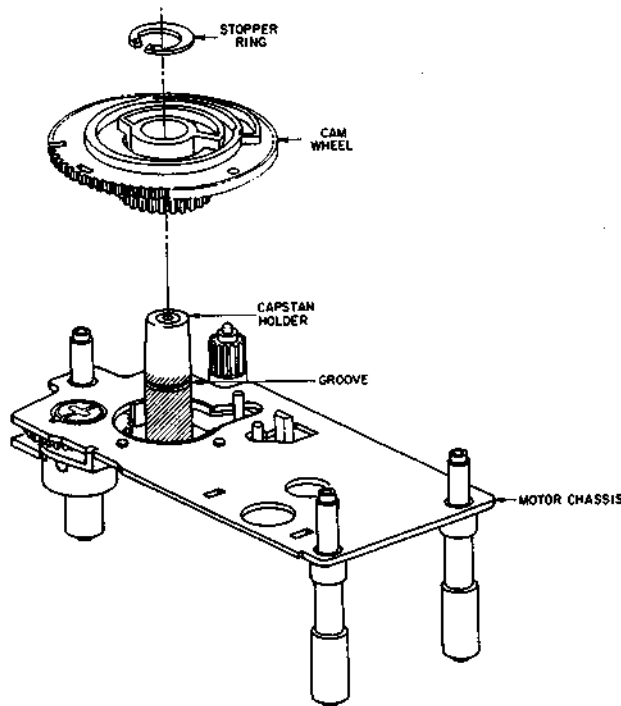

Fig. 4-11

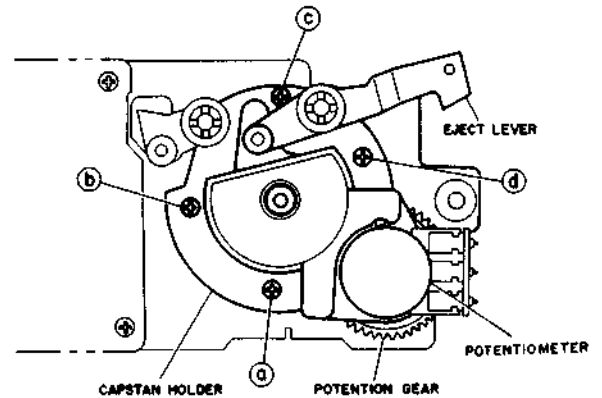

Fig. 4-12

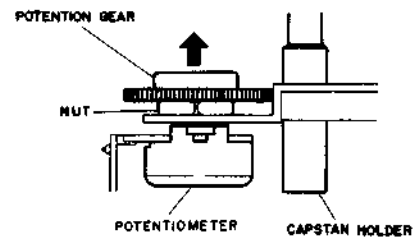

Fig. 4-13

4-7. REASSEMBLING THE CAM WHEEL AND POSITION POTENTIOMETER

- 1) Attach the position potentiometer to the capstan holder and attach the potention gear. Attach the capstan holder to the motor block and tighten the securing screws. Align the mark on the potention gear with the groove in the motor chassis as shown in Fig. 4-14.
- 2) Slide the cam wheel onto the capstan holder and position it so that the eject lever fits into the slot in the cam wheel and the center of the mark on the cam wheel aligns with the center of the chassis groove. Take care not to scratch the gear. When replacing with a new part, apply molybdenum grease to the portion of the capstan holder indicated by the slanted lines and the cam portion of the cam wheel before assembling.
- 3) After confirming that the positions of the marks on the potention gear and cam wheel are aligned with the groove in the motor chassis, attach the stopper ring.

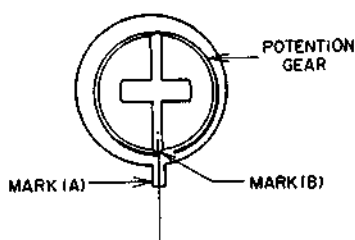

Fig. 4-14

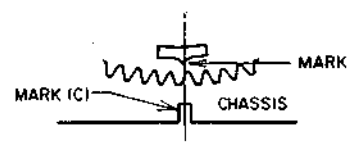

Fig. 4-15

V. MECHANICAL ADJUSTMENT

5-1. POTENTIOMETER PRESET VOLTAGE ADJUSTMENT (Refer to Fig. 5-3, 5-4)

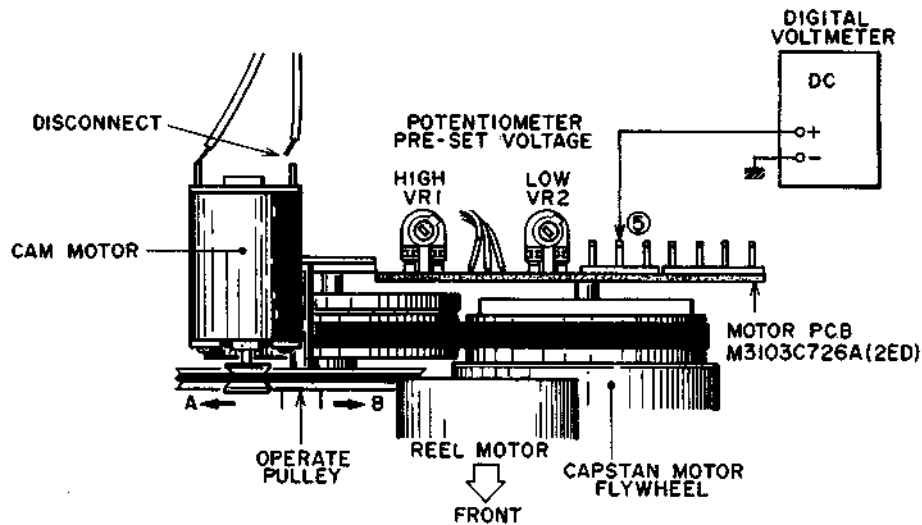

Fig. 5-1

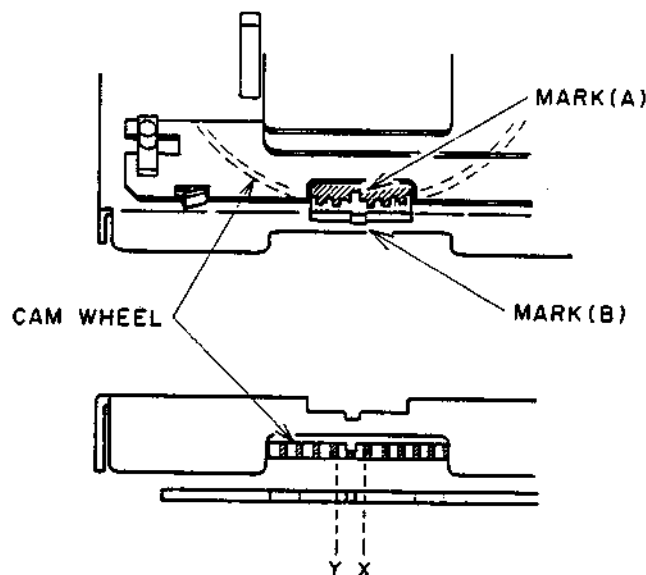

Fig. 5-2

1) LOW VOLTAGE ADJUSTMENT

- a. With power OFF, remove the connecting cord of the CAM MOTOR and turn the OPERATE PULLEY fully with your fingers in A direction. (EJECT DIRECTION)
- b. Connect the digital voltmeter as shown in Fig. 5-1.
- c. With power ON, adjust VR2 so that the reading voltage on the Digital DC Voltmeter is 1,145V.

2) HIGH VOLTAGE ADJUSTMENT

- a. With power OFF, turn the OPERATE PULLEY fully with your fingers in B direction. (PLAY DIRECTION)
- b. With power ON, adjust VR1 so that reading voltage on the Digital DC Voltmeter is 9.19V.

3) Repeat step 1) and 2).

4) With power OFF, connect the connecting cord of the CAM MOTOR.

5) Remove the Cassette lid, Front panel and Bottom cover. (Refer to I. DISASSEMBLY)

6) a. Set to power ON.

- b. Adjust VR1 slightly so that the center of marker (A) coincides with the center of marker (B) (should be within the range between X and Y) at STOP modes as shown on Fig. 5-2. (The marker (A) on the CAM WHEEL can be seen clearly by lighting it from the back.)

c. Set the IPLS switch to ON.

d. Turn the reel with fingers in STOP mode to check that the brake works sufficiently.

When the brake acts normally, the take-up reel does not turn clockwise while the supply reel does not rotate counterclockwise.

5-2. PINCH ROLLER PRESSURE MEASUREMENT (Refer to Fig. 5-3)

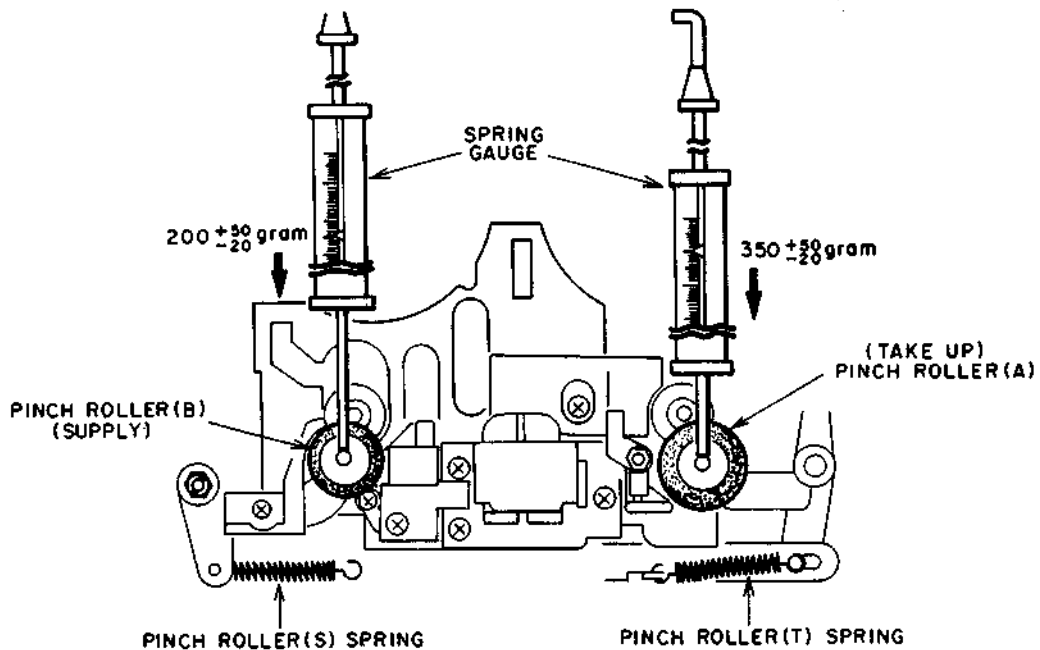

Fig. 5-3

Put in PLAY mode. Push pinch roller shaft down with the spring gauge, and push the pinch roller 1 to 2 mm away from the capstan and release slowly. Read the spring gauge at the moment the pinch roller touches the capstan and begins to rotate.

Specified pressure: 350 ⁺⁵⁰ gram (Take up)
200 ⁺⁵⁰/₋₂₀ gram (Supply)

If there is no measurement obtained, replace the pinch roller spring.

Note: Remove the cassette lid and cassette holder first. (Refer to Assembly and disassembly of the mechanism)

5-3. WINDING TORQUE MEASUREMENT IN EACH MODE (Refer to Fig. 5-4)

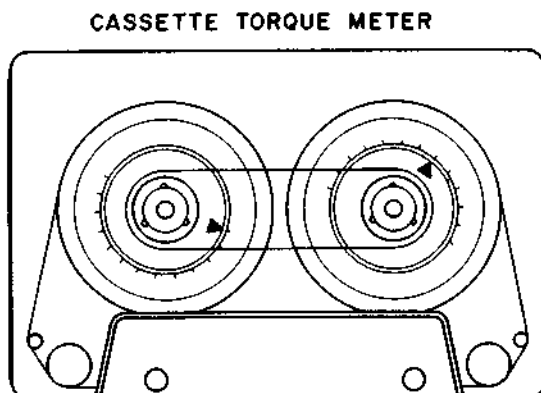

Fig. 5-4

Insert a cassette torque meter (AJ-751179) and measure in each mode. For Fast Forward and Rewind, measure at the end of the tape when the tape has stopped running.

PLAY mode

Take up Torque : 40 ⁺²⁰/₋₁₀ g-cm

Back tension torque : 10 ⁺¹⁰/₀ g-cm

FAST FORWARD, REWIND mode

Take up Torque : 120 ⁺¹³⁰/₃₀ g-cm

VI. HEAD ADJUSTMENT

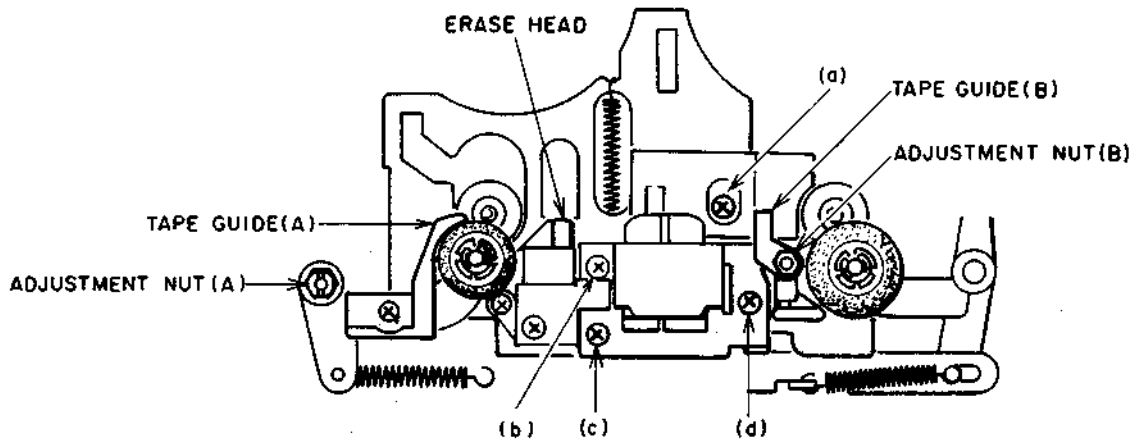

Fig. 6-1

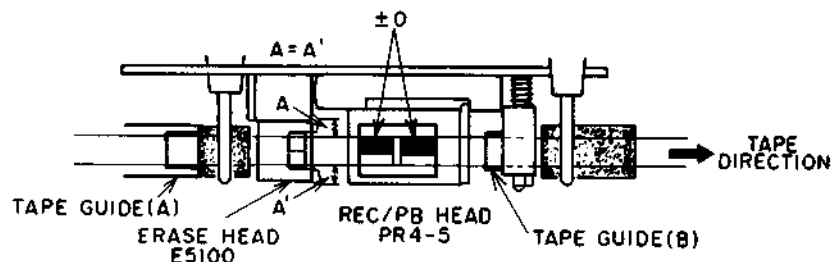

Fig. 6-2

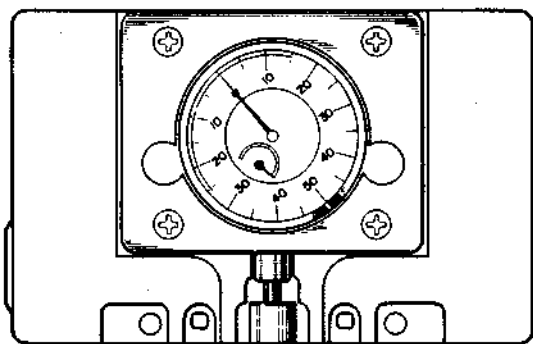

Fig. 6-3 Cassette Head Projection Gauge (AJ-751180)

6-1. REC/PB HEAD PROJECTION ADJUSTMENT

Take off the LID CASE and set the cassette head projection gauge (AJ-751180) and set to PLAY mode. Loosen the screw (a) and adjust so that the gauge indication at that time will be 3.2 ± 0.1 mm. After adjustment, apply paintlock on the screw (a).

6-2. TAPE GUIDE HEIGHT ADJUSTMENT

- 1) Set the mirror cassette tape (AJ-751178) and set to PLAY mode.
- 2) Adjust the tape guide (A) so that the parts of the erase head coming out of both sides of the tape (A and A' in Fig. 6-2) will be equal. For the adjustment, use the adjustment nut (A).
- 3) Adjust the tape guide (B) so that the tape runs smoothly and is not hitched by the tape guide. For the adjustment, use the adjustment nut (B).
- 4) After adjustment, paint-lock the adjustment nuts (A) and (B).

6-3. REC/PB HEAD HEIGHT ADJUSTMENT

- 1) Set the mirror cassette tape and set to PLAY mode.
- 2) Adjust the screws (b), (c) and (d) so that the upper edge of REC/PB head Lch core and the upper side of the tape is in alignment.
- 3) Playback the head height adjustment tape (4 Track 1,000Hz) (AT-750775), and fine-adjust the screws (b), (c) and (d) so that the largest output is obtained for both channels.

6-4. REC/PB HEAD AZIMUTH ALIGNMENT

ADJUSTMENT

- 1) Playback a 10kHz Head Azimuth Alignment Tape (AT-750778) and adjust the screw (d) until the output levels of both channels are at maximum.
- 2) Record a 10kHz, -26 dBm signal from the audio frequency oscillator.
- 3) Rewind and check for any fluctuation in the output level at playback.
- 4) After adjustment, paintlock the screws (b), (c) and (d).

- NOTES:
1. Be sure to clean the heads prior to head adjustment.
 2. Be careful not to use a magnetized driver or other magnetized tools in the vicinity of the heads.
 3. Be sure to demagnetize the heads with a Head Demagnetizer before and after head adjustment.

VI. PARTS LIST

ATTENTION

1. When placing an order for parts, be sure to list Part No., Model No. and the description of each part. Otherwise, the non-delivery of the part or the delivery of a wrong part may result.
2. Please make sure that Part No. is correct when ordering. If not, a part different from the one you ordered may be delivered.
3. Since the parts shown in Parts List of Preliminary Service Manual may have been the subject of changes, please use this Parts List for all future reference.

HOW TO USE THIS PARTS LIST

1. This Parts List lists those parts which are considered necessary for repairs. Other common parts, such as resistors and capacitors, are listed in the "Common List for Service Parts" from which these parts should be selected and stocked.
2. The Recommended Spare Parts List shows those parts in the Parts List which are considered particularly important for service.
3. Parts not shown in the Parts List and "Common List for Service Parts" will not in principle be supplied.
4. How to read the Parts List.

a) Mechanism Block

2. HEAD BASE BLOCK

REF. NO.	PART NO.	DESCRIPTION
1	BH-T2023A320A	HEAD BASE BLOCK
2	HP-H2206A010A	HEAD R/P PR4-8FU C
3	ZS-477876	PAN20×03STL CMT
4	ZS-536488	BID20×08STL CMT
5	ZG-402895	SP CS ANGLE ADJUST

SP (Service Parts) Classification

This number corresponds with the individual parts index number in that figure.

b) PC Board

6. MAIN PC BOARD

REF. NO.	PART NO.	DESCRIPTION
IC1	EI-324536	IC HD14049BP
IC2	EI-336801	IC MB8841-564M
C1A	EC-338399	C MMY V 223M 250AC [U,E,B,S]
C1B	EC-350949	C MMY V 223M 250DC [J]
C1C	EC-338397	C MMY V 223M 125AC [C,A]
X1	EI-318384	OSC X'TAL NC-18C

Symbols for primary destination

[A] : AAL (U.S.A) [S] : SAA (Australia)
 [B] : BEAB (England) [U] : U/T (Universa
 [C] : CSA (Canada) Area)
 [E] : CEE (Europe) [V] : VDE (W. Germany)
 [J] : JPN (Japan) [Y] : Custom Version

SP (Service Parts) Classification

These reference symbols correspond with component symbols in the Schematic Diagrams.

The available PC Board Blocks are listed separately.

5. When Part No. is known, Parts Index at end of Parts List can be used to locate where that part is shown in Parts List by its Reference No. listed at right of Part No.

WARNING

△(*) INDICATES SAFETY CRITICAL COMPONENTS. FOR CONTINUED SAFETY, REPLACE SAFETY CRITICAL COMPONENTS ONLY WITH MANUFACTURE'S RECOMMENDED PARTS.

AVERTISSEMENT

△(*) IL INDIQUE LES COMPOSANTS CRITIQUES DE SÉCURITÉ, POUR MAINTENIR LE Degré DE SÉCURITÉ DE L'APPAREIL, NE REMPLACER QUE DES PIÈCES RECOMMANDÉES PAR LE FABRICANT.

1. RECOMMENDED SPARE PARTS

We suggest you to stock the following Recommended Spare Part items listed below since they can cover most of the routine service.

Ref. No.	Part No.	Description
1	BM-B345196	MOTOR OPERATION (PULLEY) PART [M903 OPERATION MOTOR]
2	BR-T2069A360A	REEL TABLE BLK GX-9
3	BZ-T2030A110C	OIL CLUTCH BLK GX-6
4	ED-382895J	D LED LTZ-MR15 RED
5	ED-344244	D LED SLF-601C AMBER [D901 HOUSING LED]
6	ED-344280	D SILICON H GMA-01-FY2 F05
7	ED-624903	D SILICON H 1S2473
8	*ED-330622	D SILICON 1SR35A-100 100/1.0A
9	*ED-338322	D SILICON 10DF1 100/1.0A
10	ED-346611	D ZENER H HZ11 B3
11	ED-346549	D ZENER H HZ11B1L
12	ED-346558	D ZENER H HZ12B1L
13	ED-346567	D ZENER H HZ16-1L
14	ED-338561	D ZENER H HZ2B2FA F10
15	ED-332336	D ZENER H HZ20 3
16	ED-346594	D ZENER H HZ3 B3
17	ED-305655	D ZENER H HZ4 B3
18	ED-329058	D ZENER H HZ5 C1
19	ED-306316	D ZENER H HZ5 C2
20	ED-319167	D ZENER H HZ6 C3
21	ED-201581	D ZENER H HZ7 B1
22	ED-346609	D ZENER H HZ9 C1
23	ED-318859	D ZENER H HZ9 C2
24	ED-346538	D ZENER H HZ9A2L
25	ED-348008	D ZENER V HZ3A3S7
26	*EF-358974	FUSE BET T 250V 630MA [B]
27	*EF-601942	FUSE SEMKO T 250V 630MA [E,S]
28	*EF-306949	FUSE TSC A 250V 1.25A [U]
29	*EF-309388	FUSE TSC A 250V 800MA [U]
30	*EF-309392	FUSE TSC 125V 1.25A [C,A]
31	*EF-309391	FUSE TSC 125V 800MA [C,A]
32	EH-372101	FILTER DB 42B-5162-04
33	EI-337568	HOLE-E HE04MM07FAC
34	EI-373980	IC BA15218N
35	EI-370012	IC BA6805A
36	EI-384868J	IC BU4030B
37	EI-370022	IC HA12090NT
38	EI-355602	IC LB1649
39	EI-337006	IC LC7800
40	EI-384992J	IC M50754-106SP
41	EI-357498	IC M51143AL
42	EI-346071	IC M5218L-21
43	EI-349719	IC M5218P
44	EI-360043	IC M5220P
45	EI-362588	IC M5238P
46	EI-201940	IC NJM4558S
47	EI-336992	IC UPC1043C
48	EI-373383	IC UPC1297CA
49	EI-382875J	OSC CE CST4.00MGW 4MHZ
50	EM-384893J	IND FL BG-551GK DOUBLE
51	*EO-376998J	COIL LF LF-2C17-02
52	EO-384875J	COIL OSC 1 T2107(HX) 200KHZ
53	EO-370000	COIL OSC 1 25-2755-22 100.0KHZ
54	EQ-337067	RELAY LEAD LAB2NS 2NO 18V
55	*ER-326169	R FUSE H S10 ERD2FC 1/4W 22R0G
56	*ER-344161	R FUSE H S10 ERD2FC 1/4W 82R0G
57	ES-336990	SW LEAF BSW-169 01-1 NO [SW901 ANTI REC SW]
58	ES-337427	SW MICRO SS-01-E [SW904 LOADING SW]
59	*ES-371104	SW PUSH SODLD1082A 01-1 [POWER SW]
60	ES-384872J	SW PUSH SPUY62 6THROW [CAL/DOLBY/HX PRO/MPX]

Ref. No.	Part No.	Description
61	ES-370933	SW SLIDE SSSU 01-03N [TIMER SW]
62	ES-349474	SW TACT SKHAM004A [COUNTER RESET]
63	ET-381683J	DETECTOR A1QH3021H0
64	ET-345091	DETECTOR SPI-201-40 B,C [DET-R PCB PH1]
65	ET-356336	TR DTA114ES
66	ET-384905J	TR DTA124XF
67	ET-371075	TR DTA124XS
68	ET-370634	TR DTA143XS
69	ET-354415	TR DTA144ES
70	ET-353897	TR DTC114ES
71	ET-354365	TR DTC114YS
72	ET-382952J	TR DTC123ES
73	ET-370311	TR DTC143XS
74	ET-360824	TR DTC144EF
75	ET-354414	TR DTC144ES
76	ET-375780	TR FET 2SK381 E F05
77	ET-308472	TR 2SA1115 E,F,G F05
78	*ET-354841	TR 2SA1282A F,G F05
79	*ET-364093	TR 2SA1283 E,F F05
80	*ET-352726	TR 2SA1392 T,U
81	ET-328436	TR 2SA937 Q,R
82	ET-337760	TR 2SA984K F
83	ET-353067	TR 2SB744 P,Q,R
84	ET-328435	TR 2SC2021 R,S
85	ET-308977	TR 2SC2274K F F05
86	ET-308141	TR 2SC2603 G F05
87	*ET-365394	TR 2SC3242A E,F,G F05
88	*ET-349883	TR 2SC3243 D,E F05
89	*ET-349081	TR 2SC3383 S,T
90	ET-351123	TR 2SC3383 T
91	*ET-354083	TR 2SD1189 Q,R
92	ET-349879	TR 2SD794 P,Q,R
93	EV-384876J	VR ROTARY RK1612220 A254X2 [INPUT LEVEL]
94	EV-370008	VR ROTARY RK1631110 B202 [BIAS]
95	EV-384877J	VR ROTARY RK16312A0 B104X2 [CAL]
96	EV-373388	VR ROTARY RK16312A0 A104X2 [HEADPHONE LEVEL]
97	HE-372248	HEAD E E5100 [H902 ERASE HEAD]
98	HR-H2406A010A	HEAD COMB RP4-10HG2 [H901 REC/PB HEAD]
99	MB-336026	BELT CAPSTAN
100	MB-336021	BELT OPERATION
101	MP-336204	PINCH ROLLER (B)
102	MP-346329	PINCH ROLLER(C)
103	TC-336605	WIND IDLER ASSY

2. MECHA BLOCK

Ref. No.	Part No.	Description
4	BZ-T2030A110C	OIL CLUTCH BLK GX-6
7	ZG-341970	SP PULL OIL CLUTCH
8	ZW-270088	RING E190SUP CMT
9	ES-337427	SW MICRO SS-01-E [SW904 LOADING SW]
12	ET-345091	DETECTOR SPI-201-40 B,C [DET-R PCB PH1]
13	ET-345091	DETECTOR SPI-201-40 B,C [DET-L PCB PH1]
15	ES-336990	SW LEAF BSW-169 01-1 NO [SW901 ANTI REC SW]
16	ES-336990	SW LEAF BSW-169 01-1 NO [SW902 CRO2 DET SW]
17	ES-336990	SW LEAF BSW-169 01-1 NO [SW903 METAL DET SW]

MECHA BLOCK

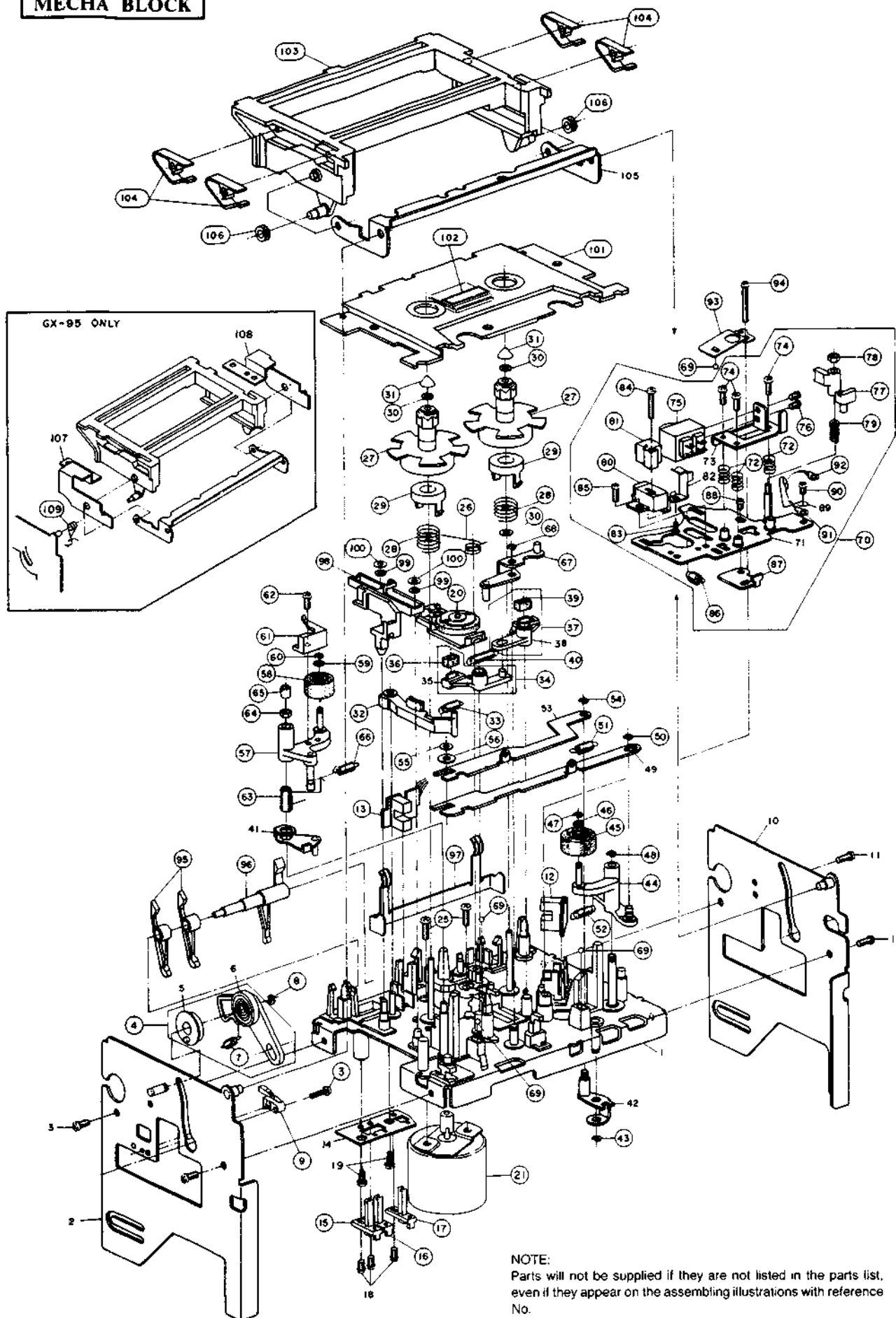

NOTE:

Parts will not be supplied if they are not listed in the parts list, even if they appear on the assembling illustrations with reference No.

Ref. No.	Part No.	Description
20	TC-336605	WIND IDLER ASSY
21	BM-T2030A120D	REEL MOTOR BLK GX-95 [M902]
25	ZS-563444	BID26X08STL CMT
26	ZG-336140	SP TORSION IDLER
27	BR-T2069A360A	REEL TABLE BLK GX-9
28	ZG-336141	SP PUSH BT
29	TC-336142	HOLDER BT SP
30	ZW-330073	PW21X040X020 TOUGH LIGHT NO440
31	MT-305793	REEL CAP
32	BL-B336196	LEVER BT PART
33	ZG-330078	SP T2-03.2/0.20-09.0 T2-038
34	BL-T2030A160A	LEVER BRAKE (A) BLK GX-F51
36	TC-336146	BRAKE RUBBER
37	BL-T2030A170A	LEVER BRAKE (B) BLK GX-F51
39	TC-336146	BRAKE RUBBER
40	ZG-312946	SP T1-03.2/0.29-16.0 T1-062
43	ZW-270088	RING E190SUP CMT
44	BL-B336150	ARM PINCH ROLLER (A) PART
45	MP-346329	PINCH ROLLER(C)
46	ZW-305546	PW21X040X025PSL
47	ZW-356657	RING E150SUP CMT
48	ZW-270088	RING E190SUP CMT
50	ZW-270088	RING E190SUP CMT
51	ZG-336175J1	SP PULL PINCH ROLLER (T)
52	ZG-321534	SP T2-03.2/0.29-12.5 T2-060
54	ZW-270088	RING E190SUP CMT
55	ZW-329422	RING CS 0300
56	ZW-306464	PW31X070X050STL CMT
57	BL-B336202	ARM PINCH ROLLER (B) PART
58	MP-336204	PINCH ROLLER (B)
59	ZW-381644	PW21X040X013PSL
60	ZW-356657	RING E150SUP CMT
61	HZ-387921J	GUIDE TAPE (B)(2)
62	ZS-608095	PAN20X05STL CMT
63	ZG-336206	SP TORSION RETURN
64	ZW-618884	N20STL CMT 1
65	ZW-356166	N
66	ZG-336206	SP PULL PINCH ROLLER (S)
67	BL-B336155	ARM HEAD SLIDE PART
68	ZW-270088	RING E190SUP CMT
69	MV-357208	BALL 200STL
70	BH-T2047A060E	HEAD BLK GX-95
72	ZG-336127	SP PUSH HEAD
74	ZS-608095	PAN20X05STL CMT
75	HR-H2406A010A	HEAD COMB RP4-10HG2 [H901 REC/PB HEAD]
76	ZS-477876	PAN20X03STL CMT
77	HZ-387920J	GUIDE TAPE(2)
78	ZW-618884	N20STL CMT 1
79	ZG-336130	SP PUSH GUIDE
80	HZ-343000	HOLDER E HEAD
81	HE-372248	HEAD E E5100 [H902 ERASE HEAD]
83	ZS-345613	T2PAN26X04STL CMT
84	ZS-365189	BT PAN26X14STL CMT
85	ZS-499331	PAN23X05STL CMT
86	ZG-341972	SP PULL HEAD RETURN
87	HZ-336132	ADJUST PLATE
88	ZS-201407	PAN23X03STL CMT
90	ZS-201407	PAN23X03STL CMT
91	ZW-305547	EL23BRS TIN 5L
92	ZW-316800	EL26BRS TIN 5L
93	ZG-336157	SP PLATE HEAD HOLD
94	ZS-342002	ST PAN26X16STL CMT
95	ML-336158	LEVER DETECTION (B)
96	ML-336159J2	LEVER DETECTOR(A)
97	ZG-336160	SP PLATE CASSETTE HOLDER (A)
98	TC-336161	SLIDE EJECT
99	ZW-306464	PW31X070X050STL CMT
100	ZW-329422	RING CS 0300
101	BD-B365352-A	LID DECORATION (A) PART
102	ED-344244	D LED SLF-601C AMBER [D901 HOUSING LED]
103	SP-336163B	LID CASE(2)
104	ZG-336615	SP PLATE CASSETTE HOLDER (B)
106	SZ-336166	COLLAR LID
109	ZG-387804J	SP TORSION RETURN [GX-95]

3. MOTOR BLM-310B BLOCK

Ref. No.	Part No.	Description
2	TC-B336004A	HOLDER CAPSTAN (C-1) PART
3	EV-337052	VR ROTARY 16L10XOR B103
4	MZ-336005	GEAR POTENTION
5	ZS-432843	PAN26X04STL CMT
6	BL-B336007	LEVER BRAKE CAM PART
7	ZW-653163	RING CS 280STL PKR
8	MZ-336006	CAM WHEEL
9	ZW-336604	RETAINING RING O S930SUP ACP
10	TC-336002	HOLDER CAPSTAN (B)
11	ZS-355818	ST BR26X04STL CMT
12	BL-B336009	LEVER EJECT CAM PART
13	MZ-353158	SP PLATE EJECT
14	ZS-477876	PAN20X03STL CMT
15	EA-336012	PC FG
16	ZS-479474	PAN26X05STL CMT
17	BF-B336024	FLYWHEEL (A) PART
18	BF-336025	FLYWHEEL (B)
19	ZW-309295	WASHER THRUST
20	MB-336026	BELT CAPSTAN
22	BA-M3103A030A	PC(#) MOTOR BLK BLM-300
23	ZS-477887	CTS26X05STL CMT
24	TC-336016	HOLDER THRUST (A)
25	TC-336027	HOLDER THRUST (B)
26	ZS-479474	PAN26X05STL CMT
27	BM-B345196	MOTOR OPERATION (PULLEY) PART (M903 OPERATION MOTOR)
29	ZS-592378	PAN26X03STL CMT
30	MR-336019	PULLEY OPERATE
31	MB-336021	BELT OPERATION
32	BM-M3104A010B	MOTOR BLM-310B (INCL. 1 TO 31)

MOTOR BLM-310B BLOCK

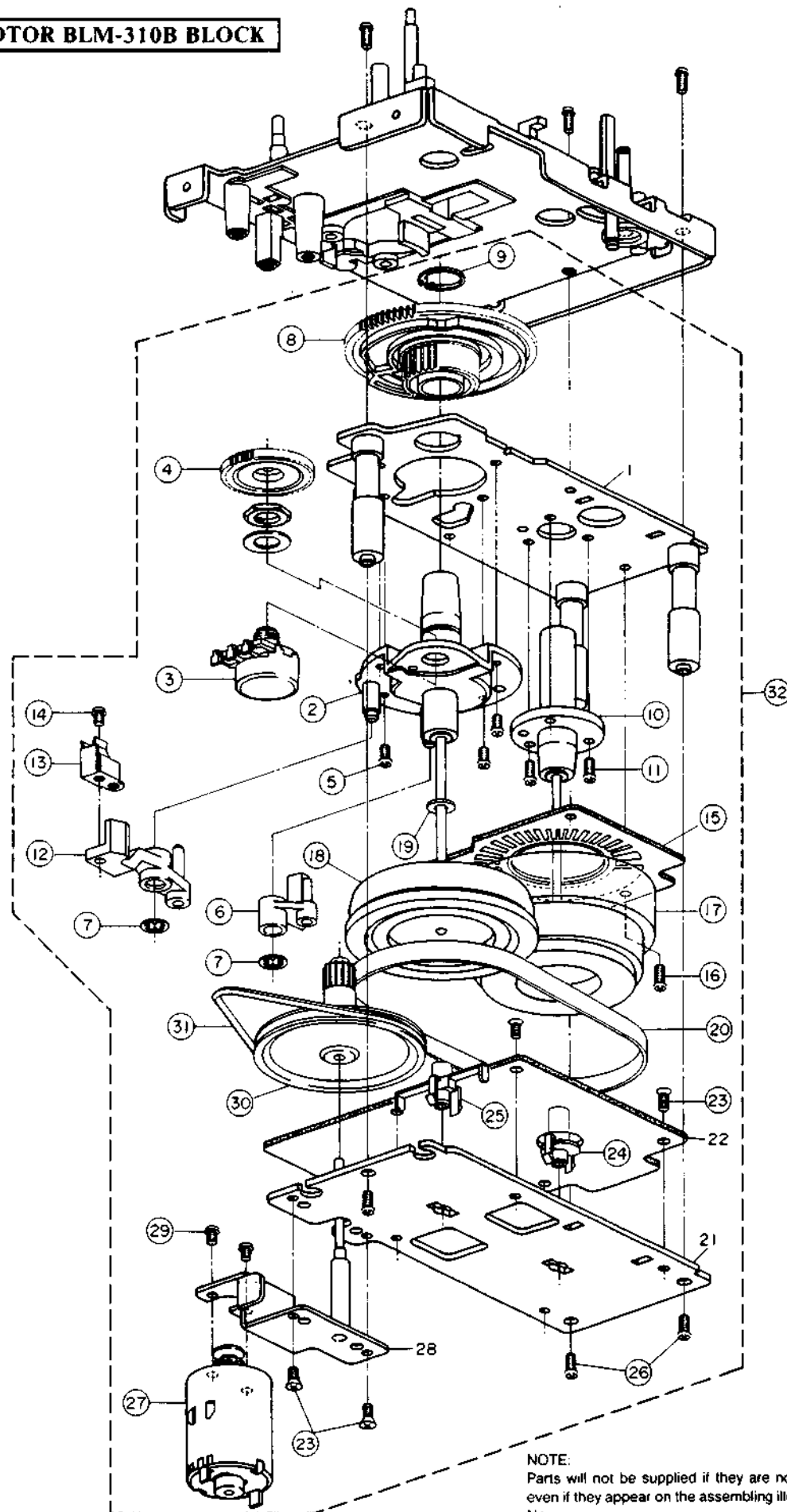

4. P.C BOARD BLOCK

Ref. No.	Part No.	Description
1A	BA-T2107A020A	PC(#) PRE AMP BLK GX-95
1B	BA-T2107A020B	PC(#) PRE AMP BLK GX-75
2	BA-T2107A030A	PC(#) SYSCON BLK GX-95

NOTE:
Parts will not be supplied if they are not listed in the parts list, even if they appear on the assembling illustrations with reference No.

5. PRE-AMP P.C BOARD

Ref. No.	Part No.	Description
D101	ED-346558	D ZENER H HZ12B1L
D102	ED-346558	D ZENER H HZ12B1L
D103	ED-382895J	D LED LTZ-MR15 RED
D104	ED-382895J	D LED LTZ-MR15 RED
D151	ED-346538	D ZENER H HZ9A2L
D152	ED-346538	D ZENER H HZ9A2L
D153	ED-344280	D SILICON H GMA-01-FY2 F05
D201	ED-344280	D SILICON H GMA-01-FY2 F05
D202	ED-344280	D SILICON H GMA-01-FY2 F05
D401	ED-346567	D ZENER H HZ16-1L
D402	ED-346567	D ZENER H HZ16-1L
D403	ED-305655	D ZENER H HZ4 B3
D404	ED-346594	D ZENER H HZ3 B3
D405	ED-344280	D SILICON H GMA-01-FY2 F05
D406	ED-344280	D SILICON H GMA-01-FY2 F05
D407	ED-344280	D SILICON H GMA-01-FY2 F05
D408	ED-344280	D SILICON H GMA-01-FY2 F05
D410	ED-344280	D SILICON H GMA-01-FY2 F05
D411	ED-344280	D SILICON H GMA-01-FY2 F05
FL151	EH-372101	FILTER DB 42B-5162-04
IC101	EI-380043	IC M5220P
IC102	EI-362588	IC M5238P
IC151	EI-370022	IC HA12090NT
IC201	EI-357498	IC M51143AL
IC202	EI-349719	IC M5218P
IC251	EI-346071	IC M5218L-21
IC331	EI-362588	IC M5238P
IC401	EI-384866J	IC BU4030B
J301A	EJ-386974J	PIN J YKC21-0373 6P GP [GX-95]
J301B	EJ-386992J	PIN J YKC21-0088A 6P [GX-75]
L101	EO-382983J	COIL FIX 1 EL0405SKI 561J
L151	EO-369997	COIL VARI 1 79-5248-13 36MH
L152	EO-369997	COIL VARI 1 79-5248-13 36MH
L153	EO-384903J	COIL FIX 1 EL0405SKI 102K
L331	EO-384870J	COIL FIX 1 25-5725-51 562J
RL201	EQ-337067	RELAY LEAD LAB2NS 2NO 18V
RL202	EQ-337067	RELAY LEAD LAB2NS 2NO 18V
SW401	ES-384872J	SW PUSH SPUY62 6THROW [CAL/DOLBY/HX PRO/MPX]
TR101	*ET-349081	TR 2SC3383 S,T
TR102	*ET-352726	TR 2SA1392 T,U
TR103	ET-352726	TR 2SA1392 T,U
TR104	ET-349081	TR 2SC3383 S,T
TR105	ET-349081	TR 2SC3383 S,T
TR106	ET-352726	TR 2SA1392 T,U
TR107	ET-349081	TR 2SC3383 S,T
TR151	ET-349979	TR 2SD794 P,Q,R
TR152	ET-353067	TR 2SB744 P,Q,R
TR153	ET-349081	TR 2SC3383 S,T
TR154	ET-349081	TR 2SC3383 S,T
TR201	ET-370311	TR DTC143XS
TR202	ET-356336	TR DTA114ES
TR203	ET-370311	TR DTC143XS
TR204	ET-356336	TR DTA114ES
TR205	ET-349081	TR 2SC3383 S,T
TR301	ET-352726	TR 2SA1392 T,U
TR333	ET-349081	TR 2SC3383 S,T
TR334	ET-349081	TR 2SC3383 S,T
TR335	ET-349081	TR 2SC3383 S,T
TR336	ET-349081	TR 2SC3383 S,T
TR337	ET-349081	TR 2SC3383 S,T
TR338	ET-349081	TR 2SC3383 S,T
TR401	ET-349979	TR 2SD794 P,Q,R
TR402	ET-353067	TR 2SB744 P,Q,R
VR101	EV-356577	R S-FIX H RH0615C 0.10W 103
VR151	EV-384876J	VR ROTARY RK1612220 A254X2 [INPUT LEVEL]
VR152	EV-357619	R S-FIX H RH0615C 0.10W 104
VR201	EV-356577	R S-FIX H RH0615C 0.10W 103
VR202	EV-357619	R S-FIX H RH0615C 0.10W 104
VR203	EV-358862	R S-FIX H RH0615C 0.10W 474
VR251	EV-373388	VR ROTARY RK16312A0 A104X2 [HEADPHONE LEVEL]

Ref. No.	Part No.	Description
VR331	EV-384877J	VR ROTARY RK16312A0 B104X2 [CAL]
VR332	EV-357619	R S-FIX H RH0615C 0.10W 104
VR551	EV-370008	VR ROTARY RK1631110 B202 [BIAS]

6. OSC P.C BOARD

Ref. No.	Part No.	Description
D501	ED-329058	D ZENER H HZ5 C1
D502	ED-329058	D ZENER H HZ5 C1
D503	ED-329058	D ZENER H HZ5 C1
D504	ED-344280	D SILICON H GMA-01-FY2 F05
D505	ED-344280	D SILICON H GMA-01-FY2 F05
FR501	*ER-344161	R FUSE H S10 ERD2FC 1/4W 82R0G
IC551	EI-373383	IC UPC1297CA
L501	EO-379951J	COIL FIX 1 7132 682J
L551	EO-382921J	COIL FIX 1 7132 272J
L552	EO-384871J	COIL FIX 1 25-2772-51 272J
R514	ER-333342	R CB H S10 FS RDS 1/4W 2R2J
R557	ER-333342	R CB H S10 FS RDS 1/4W 2R2J
TR501	ET-375780	TR FET 2SK381 E F05
TR502	*ET-349081	TR 2SC3383 S,T
TR503	*ET-349883	TR 2SC3243 D,E F05
TR504	ET-353897	TR DTC114ES
TR505	ET-353897	TR DTC114ES
TR506	ET-353897	TR DTC114ES
TR507	ET-351123	TR 2SC3383 T
TR508	ET-308977	TR 2SC2274K F F05
TR509	ET-308977	TR 2SC2274K F F05
TR551	ET-353897	TR DTC114ES
TR552	ET-349081	TR 2SC3383 S,T
T501	EO-370000	COIL OSC 1 25-2755-22 100.0KHZ
T551	EO-384875J	COIL OSC 1 T2107(HX) 200KHZ
VR501	EV-358829	R S-FIX H RH0615C 0.10W 223
VR502	EV-356584	R S-FIX H RH0615C 0.10W 224
VR552	EV-356577	R S-FIX H RH0615C 0.10W 103
VR553	EV-356576	R S-FIX H RH0615C 0.10W 472

7. HEADPHONE P.C BOARD

Ref. No.	Part No.	Description
J901	EJ-369995	PHONE J 3P HLJ0540-410 GP 6.3 [PHONES]

8. SYSCON P.C BOARD

Ref. No.	Part No.	Description
C204	EC-201645	C EC V CUT AS1 222M 6.3DC
D101	ED-624903	D SILICON H 1S2473
D102	ED-624903	D SILICON H 1S2473
D103	ED-624903	D SILICON H 1S2473
D104	ED-624903	D SILICON H 1S2473
D105	ED-624903	D SILICON H 1S2473
D106	ED-624903	D SILICON H 1S2473
D107	ED-624903	D SILICON H 1S2473
D108	ED-624903	D SILICON H 1S2473
D109	ED-624903	D SILICON H 1S2473
D110	ED-624903	D SILICON H 1S2473
D111	ED-624903	D SILICON H 1S2473
D112	ED-624903	D SILICON H 1S2473
D113	ED-624903	D SILICON H 1S2473
D114	ED-624903	D SILICON H 1S2473
D115	ED-624903	D SILICON H 1S2473
D116	ED-624903	D SILICON H 1S2473
D117	ED-624903	D SILICON H 1S2473
D118	ED-624903	D SILICON H 1S2473
D119	ED-624903	D SILICON H 1S2473
D201	ED-201581	D ZENER H HZ7 B1
D202	ED-624903	D SILICON H 1S2473
D203	ED-329058	D ZENER H HZ5 C1
D204	ED-319167	D ZENER H HZ6 C3
D205	ED-319167	D ZENER H HZ6 C3
D206	ED-624903	D SILICON H 1S2473
D207	ED-346549	D ZENER H HZ11B1L
D208	ED-346549	D ZENER H HZ11B1L
D209	ED-624903	D SILICON H 1S2473
D301	ED-306316	D ZENER H HZ5 C2
D302	ED-348008	D ZENER V HZ3A3S7
D303	ED-346611	D ZENER H HZ11 B3
D304	ED-346609	D ZENER H HZ9 C1
D305	ED-624903	D SILICON H 1S2473
D401	ED-624903	D SILICON H 1S2473
D402	ED-624903	D SILICON H 1S2473
D403	ED-624903	D SILICON H 1S2473
IB1	EH-382929J	COMP R RGL14T 223J
IC101	EI-337008	IC LC7800
IC102	EI-384892J	IC M50754-106SP
IC301	EI-355602	IC LB1649
IC302	EI-373980	IC BA15218N
IC303	EI-373980	IC BA15218N
IC501	EI-336992	IC UPC1043C
TR101	ET-371075	TR DTA124XS
TR102	ET-371075	TR DTA124XS
TR103	ET-371075	TR DTA124XS
TR104	ET-308141	TR 2SC2603 G F05
TR105	ET-308141	TR 2SC2603 G F05
TR106	ET-308141	TR 2SC2603 G F05
TR107	ET-353897	TR DTC114ES
TR108	ET-353897	TR DTC114ES
TR109	ET-308472	TR 2SA1115 E,F,G F05
TR110	ET-371075	TR DTA124XS
TR111	ET-371075	TR DTA124XS
TR112	ET-371075	TR DTA124XS
TR113	ET-371075	TR DTA124XS
TR114	ET-354414	TR DTC144ES
TR115	ET-354414	TR DTC144ES
TR116	ET-382952J	TR DTC123ES
TR117	ET-371075	TR DTA124XS
TR118	ET-354414	TR DTC144ES
TR201	ET-308141	TR 2SC2603 G F05
TR202	ET-308472	TR 2SA1115 E,F,G F05
TR203	ET-308472	TR 2SA1115 E,F,G F05
TR204	ET-354414	TR DTC144ES
TR205	ET-308141	TR 2SC2603 G F05
TR206	*ET-354083	TR 2SD1189 Q,R
TR207	*ET-365394	TR 2SC3242A E,F,G F05
TR208	*ET-354841	TR 2SA1282A F,G F05
TR301	ET-354414	TR DTC144ES
TR302	ET-354414	TR DTC144ES
TR303	ET-354414	TR DTC144ES
TR401	ET-354365	TR DTC114YS
TR402	ET-354365	TR DTC114YS
TR403	ET-354365	TR DTC114YS

Ref. No.	Part No.	Description
TR404	ET-354365	TR DTC114YS
TR405	ET-354365	TR DTC114YS
TR406	ET-354415	TR DTA144ES
TR501	ET-308141	TR 2SC2603 G F05
TR502	ET-353897	TR DTC114ES
VR501	EV-330531	R S-FIX H TM8KV2-1S 0.50W503
X101	EI-382875J	OSC CE CST4.00MGW 4MHZ

9. OPERATION P.C BOARD

Ref. No.	Part No.	Description
D601	ED-624903	D SILICON H 1S2473
D602	ED-624903	D SILICON H 1S2473
D603	ED-624903	D SILICON H 1S2473
D605	ED-624903	D SILICON H 1S2473
D606	ED-624903	D SILICON H 1S2473
D607	ED-624903	D SILICON H 1S2473
IB2	EH-382935J	COMP R RGLD6X473J
IB3	EH-382931J	COMP R RGLD15T 473J
IB4	EH-382932J	COMP R RGLD9T 473J
IC601	EI-370012	IC BA6805A
IN601	EM-384893J	IND FL BG-551GK DOUBLE
RM601	ET-381683J	DETECTOR A1QH3021H0
TR601	ET-380824	TR DTC144EF
TR602	ET-328436	TR 2SA937 Q,R
TR603	ET-384905J	TR DTA124XF
TR604	ET-354414	TR DTC144ES
TR605	ET-308472	TR 2SA1115 E,F,G F05
TR606	ET-354414	TR DTC144ES
TR607	ET-328435	TR 2SC2021 R,S
TR608	ET-384905J	TR DTA124XF
TR609	ET-384905J	TR DTA124XF
TR610	ET-370634	TR DTA143XS
TR611	ET-370634	TR DTA143XS
TR612	ET-308472	TR 2SA1115 E,F,G F05
TR613	ET-308472	TR 2SA1115 E,F,G F05
TR614	ET-308472	TR 2SA1115 E,F,G F05
TR615	ET-308472	TR 2SA1115 E,F,G F05
TS601	ES-349474	SW TACT SKHHAM004A [COUNTER RESET]
TS602	ES-349474	SW TACT SKHHAM004A [DISPLAY]
TS603	ES-349474	SW TACT SKHHAM004A [MONITOR]
TS604	ES-349474	SW TACT SKHHAM004A [REC CANCEL]
TS605	ES-349474	SW TACT SKHHAM004A [IPSS]
TS606	ES-349474	SW TACT SKHHAM004A [REC]
TS607	ES-349474	SW TACT SKHHAM004A [REW]
TS608	ES-349474	SW TACT SKHHAM004A [STOP]
TS609	ES-349474	SW TACT SKHHAM004A [MEMORY]
TS610	ES-349474	SW TACT SKHHAM004A [A-B SET]
TS611	ES-349474	SW TACT SKHHAM004A [PLAY]
TS612	ES-349474	SW TACT SKHHAM004A [FF]
TS613	ES-349474	SW TACT SKHHAM004A [AUTO MUTE]

10. TIMER P.C BOARD

Ref. No.	Part No.	Description
SW701	ES-370933	SW SLIDE SSSU 01-03N [TIMER SW]

11. POWER SUPPLY P.C BOARD

Ref. No.	Part No.	Description
C3	EC-365629	C EC V CUT AS1 102M 35.0DC
C4	EC-365629	C EC V CUT AS1 102M 35.0DC
C8	EC-365619	C EC V CUT AS1 102M 25.0DC
C9	EC-365619	C EC V CUT AS1 102M 25.0DC
C10	EC-365620	C EC V CUT AS1 472M 25.0DC
C15A	*EC-320548	C CE V F 103Z 250AC [U]
C15B	*EC-338411	C CE V FZ 103P 400AC [C,A,E,B,S]
D1	*ED-338322	D SILICON 10DF1 100/1.0A
D2	*ED-338322	D SILICON 10DF1 100/1.0A
D3	*ED-330622	D SILICON 1SR35A-100 100/1.0A
D4	*ED-330622	D SILICON 1SR35A-100 100/1.0A
D5	*ED-330622	D SILICON 1SR35A-100 100/1.0A
D6	*ED-330622	D SILICON 1SR35A-100 100/1.0A
D7	*ED-338322	D SILICON 10DF1 100/1.0A
D8	*ED-338322	D SILICON 10DF1 100/1.0A
D9	*ED-330622	D SILICON 1SR35A-100 100/1.0A
D10	*ED-330622	D SILICON 1SR35A-100 100/1.0A
D11	*ED-330622	D SILICON 1SR35A-100 100/1.0A
D12	*ED-330622	D SILICON 1SR35A-100 100/1.0A
D13	*ED-330622	D SILICON 1SR35A-100 100/1.0A
D14	*ED-330622	D SILICON 1SR35A-100 100/1.0A
D15	*ED-330622	D SILICON 1SR35A-100 100/1.0A
D16	*ED-330622	D SILICON 1SR35A-100 100/1.0A
D17	*ED-330622	D SILICON 1SR35A-100 100/1.0A
D18	*ED-330622	D SILICON 1SR35A-100 100/1.0A
D19	ED-332336	D ZENER H HZ20 3
D20	ED-318859	D ZENER H HZ9 C2
D21	ED-318859	D ZENER H HZ9 C2
FL1	*EO-376998J	COIL LF LF-2C17-02
FR1	*ER-326169	R FUSE H S10 ERD2FC 1/4W 22R0G
FR2	*ER-326169	R FUSE H S10 ERD2FC 1/4W 22R0G
SW1	*ES-371104	SW PUSH SDDL1082A 01-1 [POWER SW]
TR1	*ET-384093	TR 2SA1283 E,F F05
TR2	*ET-365394	TR 2SC3242A E,F,G F05
TR3	*ET-354841	TR 2SA1282A F,G F05
F1A	*EF-309388	FUSE TSC A 250V 800MA [U]
F2A	*EF-309388	FUSE TSC A 250V 800MA [U]
F3A	*EF-306949	FUSE TSC A 250V 1.25A [U]
F4A	*EF-306949	FUSE TSC A 250V 1.25A [U]
F1B	*EF-309391	FUSE TSC 125V 800MA [C,A]
F2B	*EF-309391	FUSE TSC 125V 800MA [C,A]
F3B	*EF-309392	FUSE TSC 125V 1.25A [C,A]
F4B	*EF-309392	FUSE TSC 125V 1.25A [C,A]
F1C	*EF-601942	FUSE SEMKO T 250V 630MA [E,S]
F2C	*EF-601942	FUSE SEMKO T 250V 630MA [E,S]
F3C	*EF-601942	FUSE SEMKO T 250V 630MA [E,S]
F4C	*EF-601942	FUSE SEMKO T 250V 630MA [E,S]
F1D	*EF-358974	FUSE BET T 250V 630MA [B]
F2D	*EF-358974	FUSE BET T 250V 630MA [B]
F3D	*EF-358974	FUSE BET T 250V 630MA [B]
F4D	*EF-358974	FUSE BET T 250V 630MA [B]

12. MOTOR P.C BOARD

Ref. No.	Part No.	Description
D5	ED-338561	D ZENER H HZ2B2FA F10
IC1	EI-201940	IC NJM4558S
IC2	EI-201940	IC NJM4558S
IC3	EI-337568	HOLE-E HE04MH07FAC
IC4	EI-337568	HOLE-E HE04MH07FAC
TR1	ET-308977	TR 2SC2274K F F05
TR2	ET-337760	TR 2SA984K F
TR3	ET-308977	TR 2SC2274K F F05
TR4	ET-337760	TR 2SA984K F
VR1	EV-464253	R S-FIX V V8K1-1 0.10W 202
VR2	EV-464253	R S-FIX V V8K1-1 0.10W 202

FINAL ASSEMBLY BLOCK

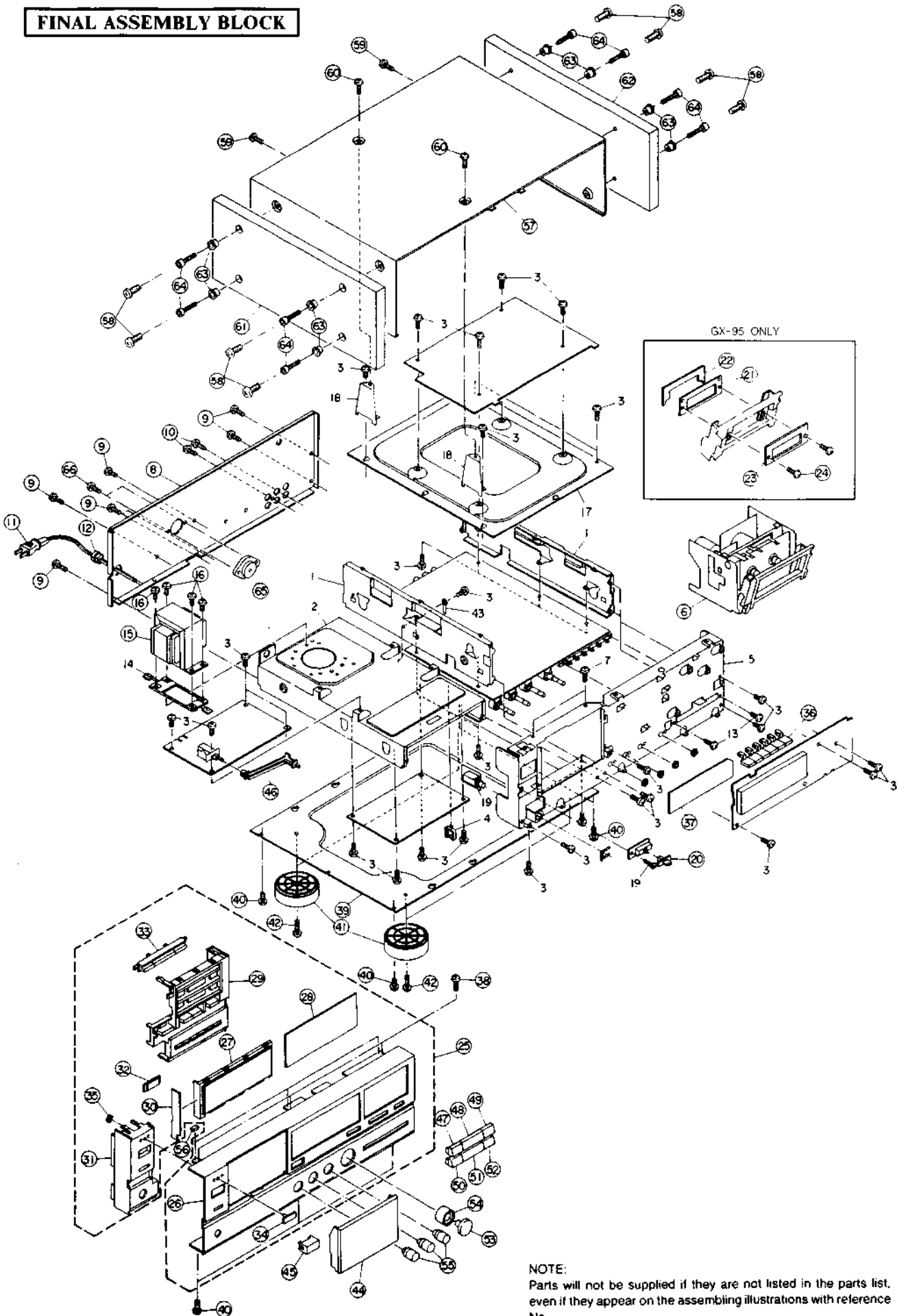

NOTE:
Parts will not be supplied if they are not listed in the parts list, even if they appear on the assembling illustrations with reference No.

PARTS LIST

13. FINAL ASSEMBLY BLOCK

Ref. No.	Part No.	Description
6A	BB-T2047A020F	MECHA BLK GX-95
6B	BB-T2047A020G	MECHA BLK GX-75
8A	SP-384092J	PANEL REAR GX-95 U/T [U]
8B	SP-384094J	PANEL REAR GX-95 CA [C,A]
8C	SP-384095J	PANEL REAR GX-95 E [E]
8D	SP-384097J	PANEL REAR GX-95 BS [B,S]
8E	SP-387839J	PANEL REAR GX-75 E [E]
9	ZS-376523	ST BID30X06STL BNI EARTH LOCK
10	ZS-350934	PT BR30X08STL BNI
11A	*EW-374894	AC CORD 2C VM-0129A,VFF U/T [U]
11B	*EW-373139	AC CORD220 KP10 SPT2 A UC [C,A]
11C	*EW-336923	AC CORD 2C KP-419C,LTCE-2F EV [E]
11D	*EW-346249	AC CORD 2 CORES LCFL2X0.75 B [B]
11E	*EW-347898	AC CORD 2 CORES VM-0436,LCFL S [S]
12	*EZ-631945	STRAIN RELIEF SR-4N-4
15A	*BT-384841J	TRANS POW T2107(U) [U] [T901]
15B	*BT-384843J	TRANS POW T2107(A,C) [C,A] [T901]
15C	*BT-384844J	TRANS POW T2107(E) [E] [T901]
15D	*BT-384845J	TRANS POW T2107(B,S) [B,S] [T901]
16	ZS-301576	ST PAN40X10STL CMT
20	SK-358066B	KNOB SLIDE-BLACK
21	SP-385721J	PLATE DECORATION
22	SZ-388434J	SHEET DAMP
23	SE-385722J	PLATE DECORATION
24	ZS-387752J	6RB26X030SCM BZN
25A	BD-T2107A050A	PANEL FRONT BLK GX-95-B
25B	BD-T2107A050D	PANEL FRONT BLK GX-75-B
27	SE-382435J	WINDOW METER
28	SE-384090J	FILTER FLD
29	SK-384075J	KNOB OPERATE B
30	SZ-384061J	MASK
31	SP-384072J	ESCUTCHEON SIDE B
32	SE-384838J	WINDOW REMOCON
33	SK-384079J	KNOB B
34	SM-385756C	NAME PLATE AKA(2)
35	MZ-353163	COLLAR
36	SK-384077J	KNOB PUSH B
37	SE-384091J	MASK VR
38	ZS-358896	ST BID30X06STL CMT
39	SP-384060J	CHASSIS BOTTOM
40	ZS-305827	ST BID30X06STL BNI
41	SA-384105J	FOOT ROUND SHAPED(N)
42	ZS-352133	ST BR30X10STL CMT
44	BD-T2107A060A	LID PANEL BLK GX-95-B
45	SK-373236B	KNOB POWER-B
46	MZ-384059J	JOINT POW
47	SK-373337C	KNOB OPERATION(B) REW-BLACK
48	SK-373336C	KNOB OPERATION(A) PLAY-BLACK
49	SK-373337A	KNOB OPERATION(B) FF-BLACK
50	SK-373337E	KNOB OPERATION(B) PAUSE-BLACK
51	SK-373336A	KNOB OPERATION(A) STOP-BLACK
52	SK-373337G	KNOB OPERATION(B) MUTE B
53	SK-384083J	KNOB REC(L) B PART
54	SK-384088J	KNOB REC(R) B PART
55	SK-381051J	KNOB VR-B(2) PART
56	ZW-373128	SPACER
57	SP-384100J	COVER UPPER B
58	ZS-341960	ST BID40X06STL BNI [GX-75]
59	ZS-376523	ST BID30X06STL BNI EARTH LOCK
60	ZS-381482J	SCREW TOP COVER(3) B OM

Ref. No.	Part No.	Description
61	SP-384102J	SIDEBOARD(L) [GX-95]
62	SP-384101J	SIDEBOARD(R) [GX-95]
63	ZW-376292	WASHER SIDE BOARD [GX-95]
64	ZS-376293	SCREW SIDE BOARD [GX-95]
65	*ES-359606	SW SELECTOR JUH1420-0201 01-4 [U] [GX-95][SW901]
66	ZW-241200	RV NYL30X080 BL [U] [GX-95]

14. ACCESSARY

Ref. No.	Part No.	Description
1	AX-383067J	CORD R-222P PINX2-PINX2
2	AX-384837J	REMOCON RC-G95 [GX-95]

15. REMOTE CONTROL UNIT RC-G95 (GX-95)

Ref. No.	Part No.	Description
1	SC-728112J	CASE BATTERY GX-Z9100R

INDEX

Part No.	Ref. No.	Part No.	Ref. No.	Part No.	Ref. No.	Part No.	Ref. No.
AX-383067J	14-1	ED-338322	11-D2	EF-309388	11-F2A	EQ-337067	1-54
AX-384837J	14-2	ED-338322	11-D7	EF-309391	1-31	EQ-337067	5-RL201
BA-M3103A030A	3-22	ED-338322	11-D8	EF-309391	11-F1B	EQ-337067	5-RL202
BA-T2107A020A	4-1A	ED-338561	1-14	EF-309391	11-F2B	ER-326169	1-55
BA-T2107A020B	4-1B	ED-338561	12-D5	EF-309392	1-30	ER-326169	11-FR1
BA-T2107A030A	4-2	ED-344244	1-5	EF-309392	11-F3B	ER-326169	11-FR2
BB-T2047A020F	13-6A	ED-344244	2-102	EF-309392	11-F4B	ER-333342	6-R514
BB-T2047A020G	13-6B	ED-344280	1-6	EF-358974	1-26	ER-333342	6-R557
BD-B365352-A	2-101	ED-344280	5-D153	EF-358974	11-F1D	ER-344161	1-56
BD-T2107A050A	13-25A	ED-344280	5-D201	EF-358974	11-F2D	ER-344161	6-FR501
BD-T2107A050D	13-25B	ED-344280	5-D202	EF-358974	11-F3D	ES-336990	1-57
BD-T2107A060A	13-44	ED-344280	5-D405	EF-358974	11-F4D	ES-336990	2-15
BF-336025	3-18	ED-344280	5-D406	EF-601942	1-27	ES-336990	2-16
BF-B336024	3-17	ED-344280	5-D407	EF-601942	11-F1C	ES-336990	2-17
BH-T2047A060E	2-70	ED-344280	5-D408	EF-601942	11-F2C	ES-337427	1-58
BL-B336007	3-6	ED-344280	5-D410	EF-601942	11-F3C	ES-337427	2-9
BL-B336009	3-12	ED-344280	5-D411	EF-601942	11-F4C	ES-349474	1-62
BL-B336150	2-44	ED-344280	6-D504	EH-372101	1-32	ES-349474	9-TS601
BL-B336155	2-67	ED-344280	6-D505	EH-372101	5-FL151	ES-349474	9-TS602
BL-B336196	2-32	ED-346538	1-24	EH-382929J	8-IB1	ES-349474	9-TS603
BL-B336202	2-57	ED-346538	5-D151	EH-382931J	9-IB3	ES-349474	9-TS604
BL-T2030A160A	2-34	ED-346538	5-D152	EH-382932J	9-IB4	ES-349474	9-TS605
BL-T2030A170A	2-37	ED-346549	1-11	EH-382935J	9-IB2	ES-349474	9-TS606
BM-B345196	1-1	ED-346549	8-D207	EI-201940	1-46	ES-349474	9-TS607
BM-B345196	3-27	ED-346549	8-D208	EI-201940	12-IC1	ES-349474	9-TS608
BM-M3104A010B	3-32	ED-346558	1-12	EI-201940	12-IC2	ES-349474	9-TS609
BM-T2030A120D	2-21	ED-346558	5-D101	EI-336992	1-47	ES-349474	9-TS610
BR-T2069A360A	1-2	ED-346558	5-D102	EI-336992	8-IC501	ES-349474	9-TS611
BR-T2069A360A	2-27	ED-346567	1-13	EI-337008	1-39	ES-349474	9-TS612
BT-384841J	13-15A	ED-346567	5-D401	EI-337008	8-IC101	ES-349474	9-TS613
BT-384843J	13-15B	ED-346567	5-D402	EI-337568	1-33	ES-359606	13-65
BT-384844J	13-15C	ED-346594	1-16	EI-337568	12-IC3	ES-370933	1-61
BT-384845J	13-15D	ED-346594	5-D404	EI-337568	12-IC4	ES-370933	10-SW701
BZ-T2030A110C	1-3	ED-346609	1-22	EI-346071	1-42	ES-371104	1-59
BZ-T2030A110C	2-4	ED-346609	8-D304	EI-346071	5-IC251	ES-371104	11-SW1
EA-336012	3-15	ED-346611	1-10	EI-349719	1-43	ES-384872J	1-60
EC-201645	8-C204	ED-346611	8-D303	EI-349719	5-IC202	ES-384872J	5-SW401
EC-320548	11-C15A	ED-348008	1-25	EI-355602	1-38	ET-308141	1-86
EC-338411	11-C15B	ED-348008	8-D302	EI-355602	8-IC301	ET-308141	8-TR104
EC-365619	11-C8	ED-382895J	1-4	EI-357498	1-41	ET-308141	8-TR105
EC-365619	11-C9	ED-382895J	5-D103	EI-357498	5-IC201	ET-308141	8-TR106
EC-365620	11-C10	ED-382895J	5-D104	EI-360043	1-44	ET-308141	8-TR201
EC-365629	11-C3	ED-624903	1-7	EI-360043	5-IC101	ET-308141	8-TR205
EC-365629	11-C4	ED-624903	8-D101	EI-362588	1-45	ET-308141	8-TR501
ED-201581	1-21	ED-624903	8-D102	EI-362588	5-IC102	ET-308472	1-77
ED-201581	8-D201	ED-624903	8-D103	EI-362588	5-IC331	ET-308472	8-TR109
ED-305655	1-17	ED-624903	8-D104	EI-370012	1-35	ET-308472	8-TR202
ED-305655	5-D403	ED-624903	8-D105	EI-370012	9-IC601	ET-308472	8-TR203
ED-306316	1-19	ED-624903	8-D106	EI-370022	1-37	ET-308472	9-TR605
ED-306316	8-D301	ED-624903	8-D107	EI-370022	5-IC151	ET-308472	9-TR612
ED-318859	1-23	ED-624903	8-D108	EI-373383	1-48	ET-308472	9-TR613
ED-318859	11-D20	ED-624903	8-D109	EI-373383	6-IC551	ET-308472	9-TR614
ED-318859	11-D21	ED-624903	8-D110	EI-373980	1-34	ET-308472	9-TR615
ED-319167	1-20	ED-624903	8-D111	EI-373980	8-IC302	ET-308977	1-85
ED-319167	8-D204	ED-624903	8-D112	EI-373980	8-IC303	ET-308977	6-TR508
ED-319167	8-D205	ED-624903	8-D113	EI-382875J	1-49	ET-308977	6-TR509
ED-329058	1-18	ED-624903	8-D114	EI-382875J	8-X101	ET-308977	12-TR1
ED-329058	6-D501	ED-624903	8-D115	EI-384868J	1-36	ET-308977	12-TR3
ED-329058	6-D502	ED-624903	8-D116	EI-384868J	5-IC401	ET-328435	1-84
ED-329058	6-D503	ED-624903	8-D117	EI-384892J	1-40	ET-328435	9-TR607
ED-329058	8-D203	ED-624903	8-D118	EI-384892J	8-IC102	ET-328436	1-81
ED-330622	1-8	ED-624903	8-D119	EJ-369995	7-J901	ET-328436	9-TR602
ED-330622	11-D3	ED-624903	8-D202	EJ-386974J	5-J301A	ET-337760	1-82
ED-330622	11-D4	ED-624903	8-D206	EJ-386992J	5-J301B	ET-337760	12-TR2
ED-330622	11-D5	ED-624903	8-D209	EM-384893J	1-50	ET-337760	12-TR4
ED-330622	11-D6	ED-624903	8-D305	EM-384893J	9-IN601	ET-345091	1-64
ED-330622	11-D9	ED-624903	8-D401	EO-389997	5-L151	ET-345091	2-12
ED-330622	11-D10	ED-624903	8-D402	EO-389997	5-L152	ET-345091	2-13
ED-330622	11-D11	ED-624903	8-D403	EO-370000	1-53	ET-349081	1-89
ED-330622	11-D12	ED-624903	9-D601	EO-370000	6-T501	ET-349081	5-TR101
ED-330622	11-D13	ED-624903	9-D602	EO-376998J	1-51	ET-349081	5-TR104
ED-330622	11-D14	ED-624903	9-D603	EO-376998J	11-FL1	ET-349081	5-TR105
ED-330622	11-D15	ED-624903	9-D605	EO-379951J	6-L501	ET-349081	5-TR107
ED-330622	11-D16	ED-624903	9-D606	EO-382921J	6-L551	ET-349081	5-TR153
ED-330622	11-D17	ED-624903	9-D607	EO-382983J	5-L101	ET-349081	5-TR154
ED-330622	11-D18	EF-306949	1-28	EO-384870J	5-L331	ET-349081	5-TR205
ED-332336	1-15	EF-306949	11-F3A	EO-384871J	6-L552	ET-349081	5-TR333
ED-332336	11-D19	EF-306949	11-F4A	EO-384875J	1-52	ET-349081	5-TR334
ED-338322	1-9	EF-309388	1-29	EO-384875J	6-T551	ET-349081	5-TR335
ED-338322	11-D1	EF-309388	11-F1A	EO-384903J	5-L153	ET-349081	5-TR336

AKAI

MODEL **GX-75**

MODEL **GX-95**

SCHEMATIC DIAGRAM AND PC BOARDS

TABLE OF CONTENTS

1. MOTOR PC BOARD	2
2. POWER SUPPLY PC BOARD	3
3. OPERATION PC BOARDS	4
4. CONNECTION DIAGRAM	5
5. PRE AMP AND OSC SCHEMATIC DIAGRAM	6
6. PRE AMP AND OSC PC BOARDS	7
7. SYS-CON SCHEMATIC DIAGRAM	8
8. SYS-CON PC BOARD	9
9. BLOCK DIAGRAM	10

TO POTENTION
ポテンション ボリューム調整へ

TO SYSCON PCB P2
シスコン基板 P2へ

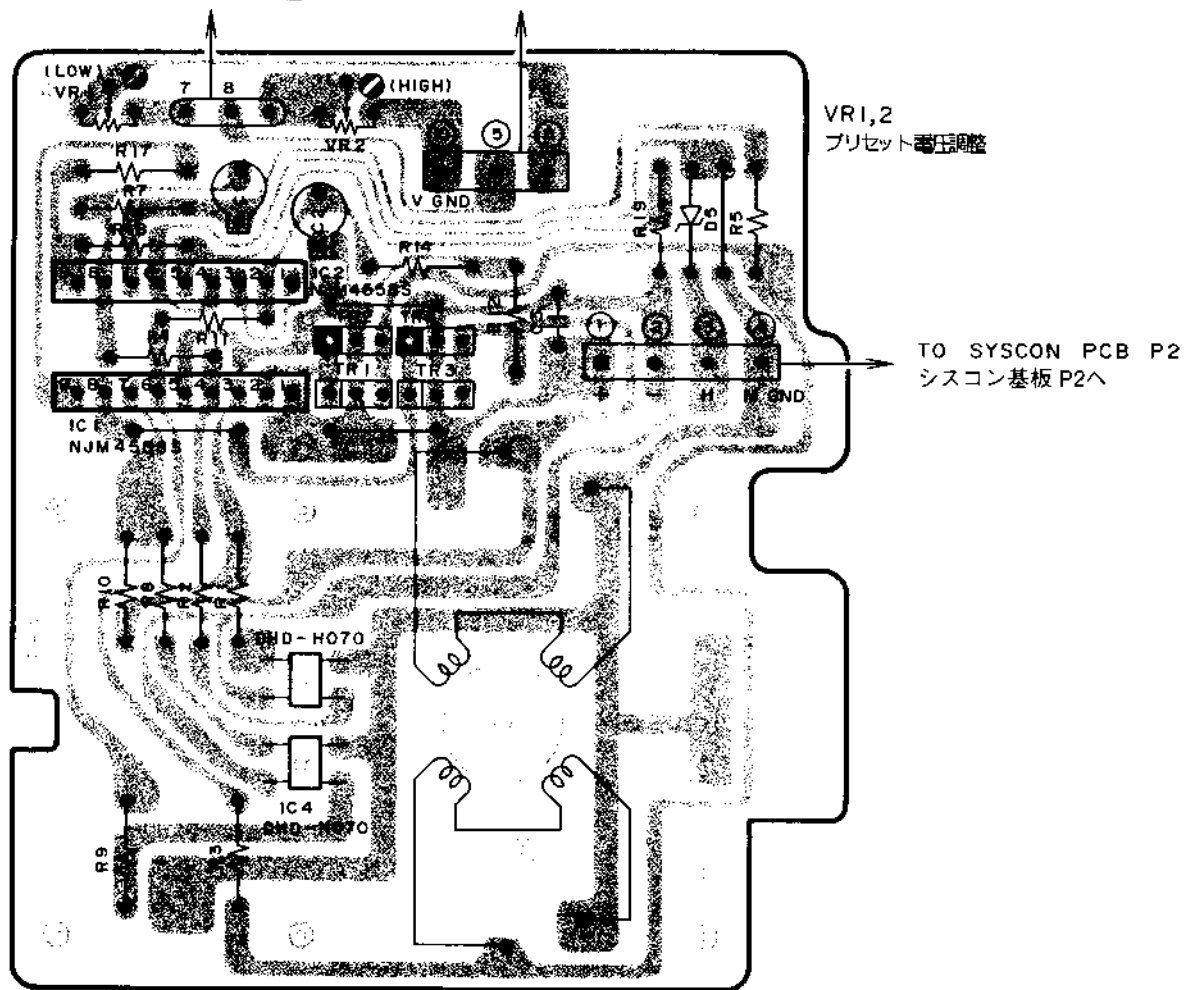



VR1,2
プリセット 電圧調整

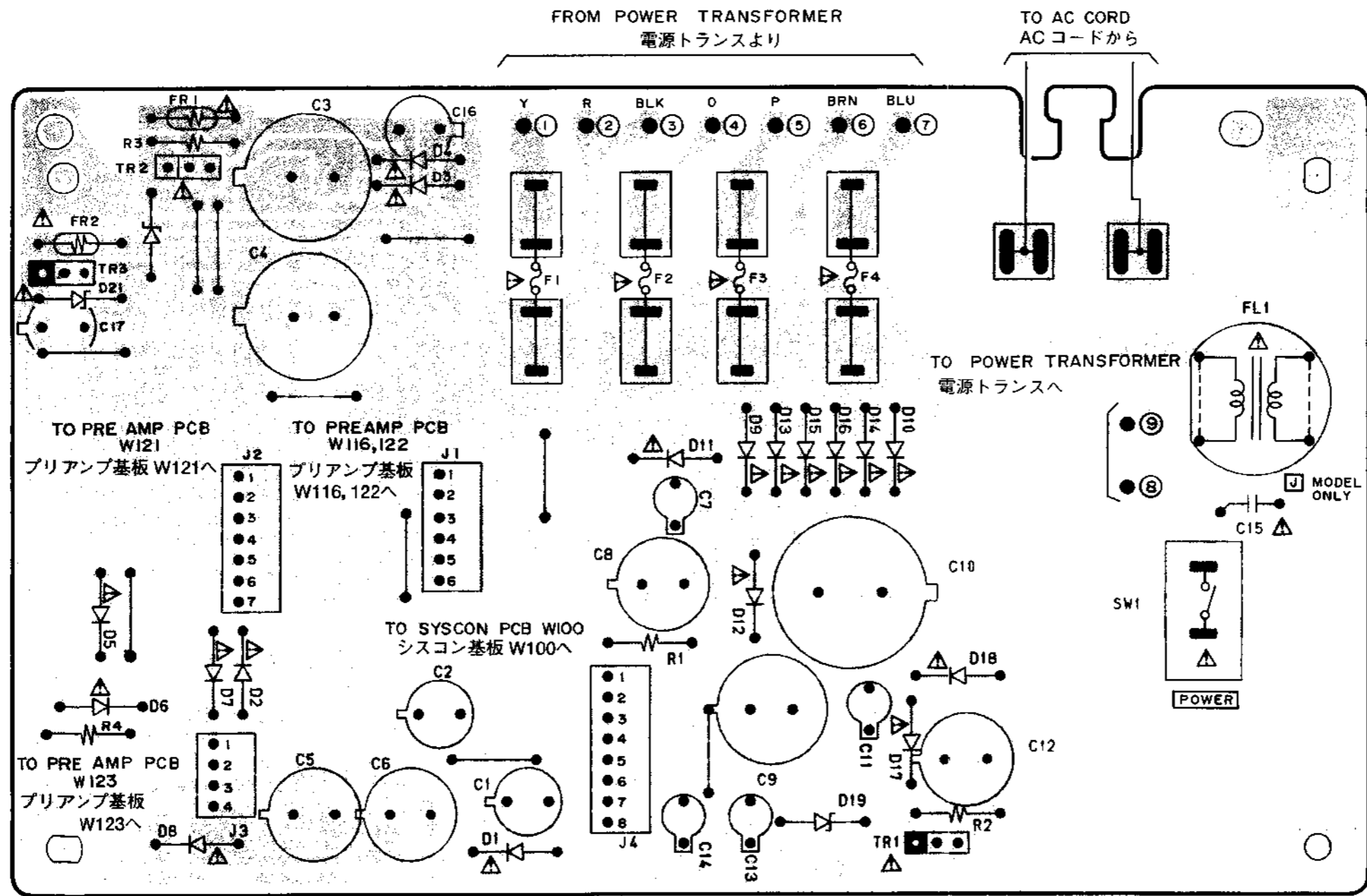

TO SYSCON PCB P2
シスコン基板 P2へ

MOTOR PCB
モーター基板
M3103C726A (J2)



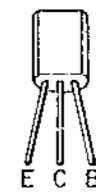

POWER SUPPLY PCB T2107C5030
電源基板

 PNP TRANSISTOR
トランジスタ
 NPN TRANSISTOR
トランジスタ

 E C B
2SA1283
2SC3242A
 C B E
2SA1218

注意 への付された部品は、安全上重要部品です。交換の際は、指定部品以外は使用しないこと。

WARNING:  INDICATES SAFETY CRITICAL COMPONENTS. FOR CONTINUED SAFETY, REPLACE SAFETY CRITICAL COMPONENTS ONLY WITH MANUFACTURER'S RECOMMENDED PARTS.
 AVERTISSEMENT:  IL INDIQUE LES COMPOSANTS CRITIQUES DE SÉCURITÉ. POUR MAINTENIR LE DEGRÉ DE SÉCURITÉ DE L'APPAREIL, NE REMPLACER QUE DES PIÈCES RECOMMANDÉES PAR LE FABRICANT.

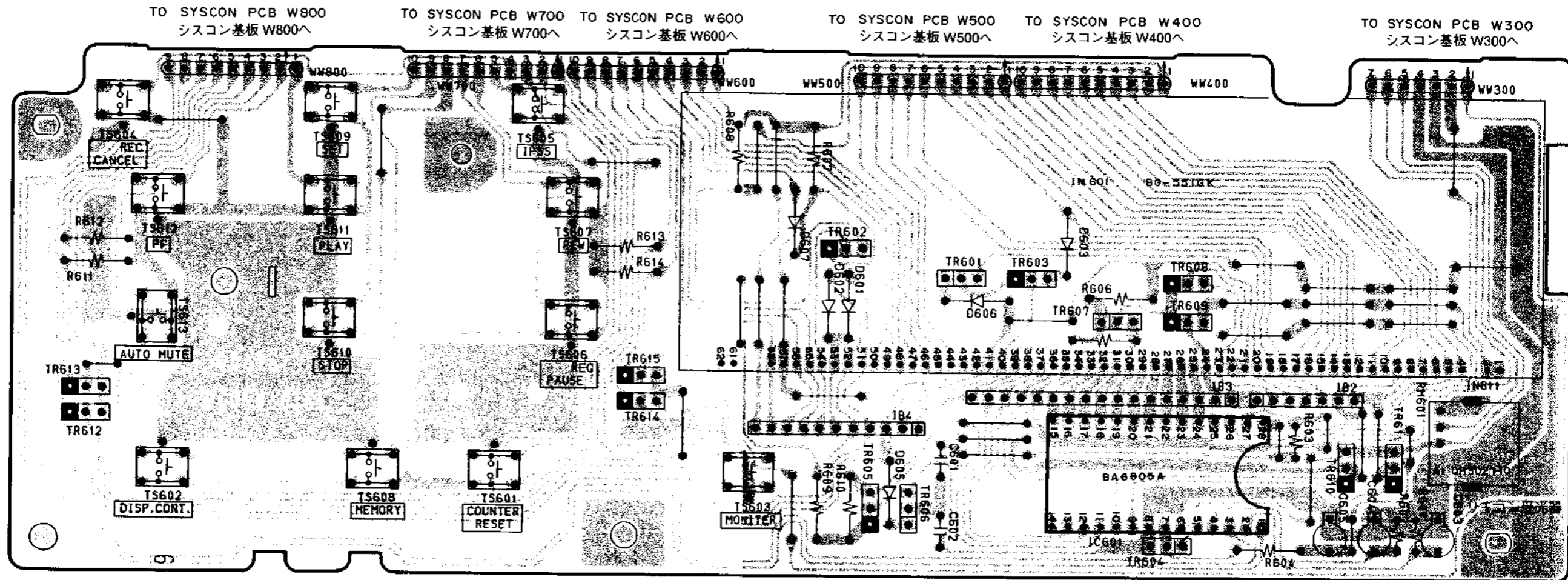

OPERATION PCB
オペレーション基板
T2107A502B

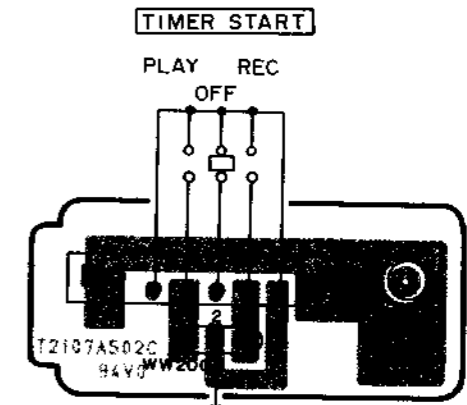
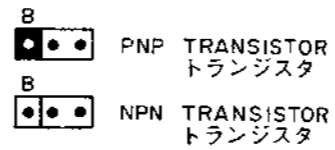
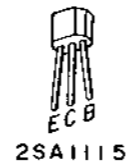
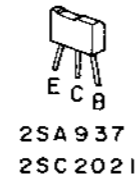
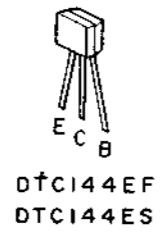

TO SYSCON PCB W200
シスコン基板 W200へ

TIMER PCB
タイマー基板
T2107N502C

ヘッドホン基板 HEAD PHONE PCB
T2107A501C T2107028

リールセンサー (R) 基板 REEL SENSOR (R) PCB
T2069D5020

リールセンサー (L) 基板 REEL SENSOR (L) PCB
T2069D5010

タイマー基板 TIMER PCB
T2107A502C

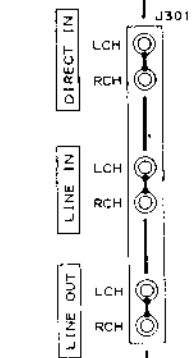
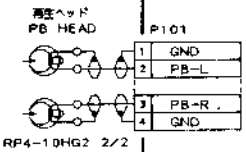
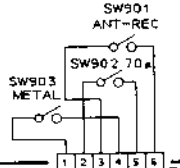
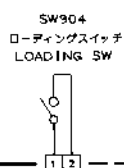
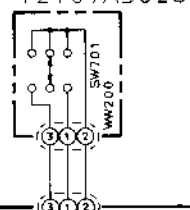
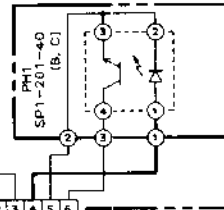
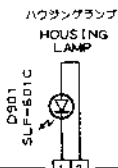
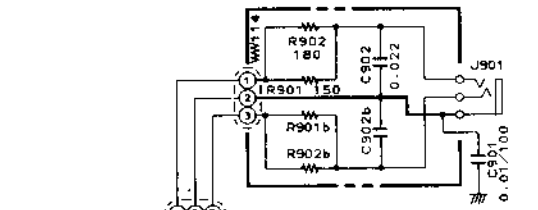

プリアンプ基板
PRE AMP PCB
T2107A501A

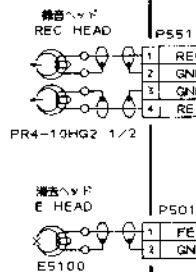
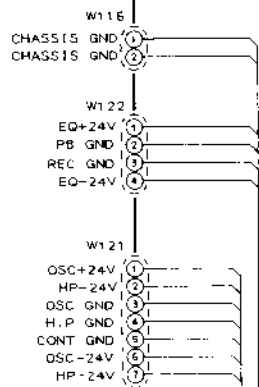

オシレータ基板
OSC PCB
T2107A501B

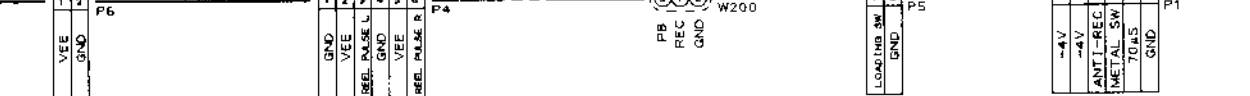
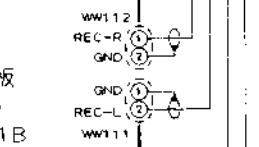

シスコン基板
SYSCON PCB
T2107A502A

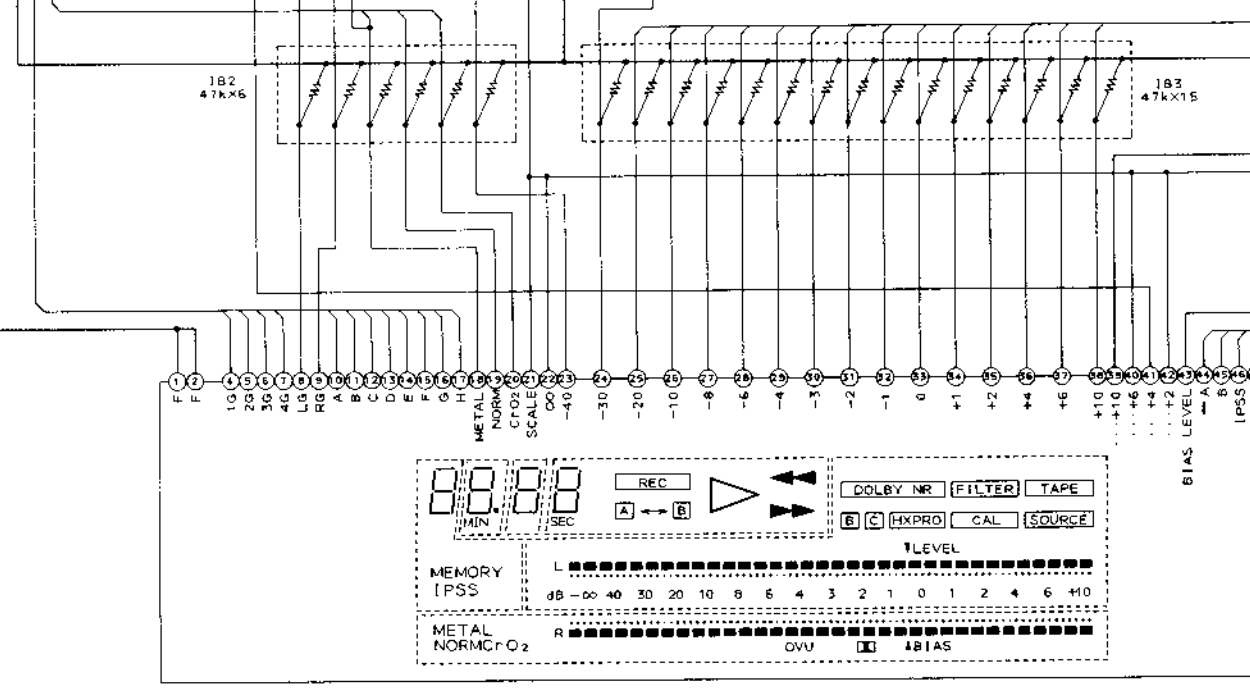
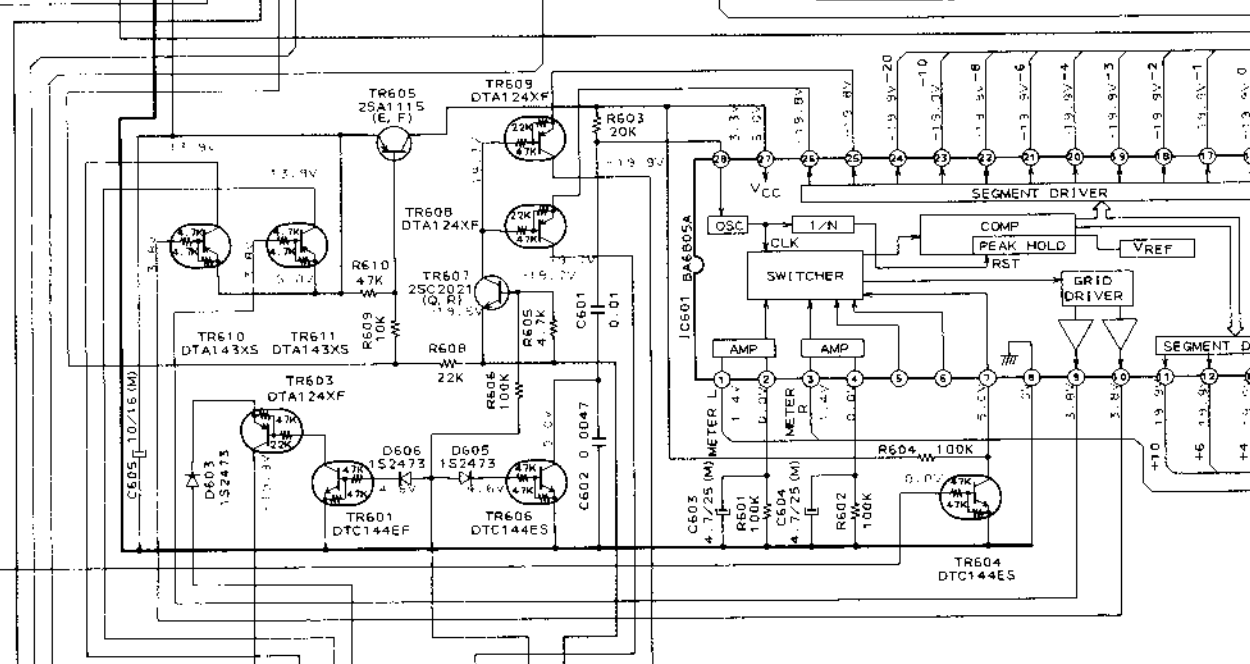
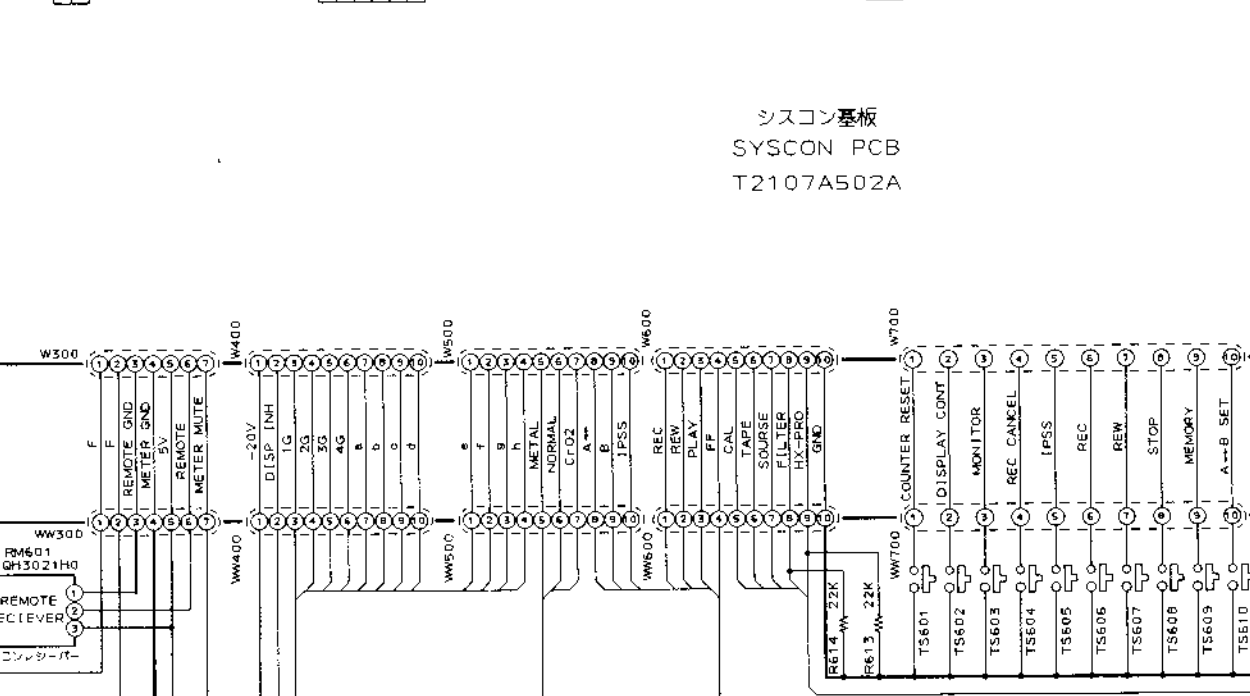

オペレーション基板 OPERATION PCB T2107A502B

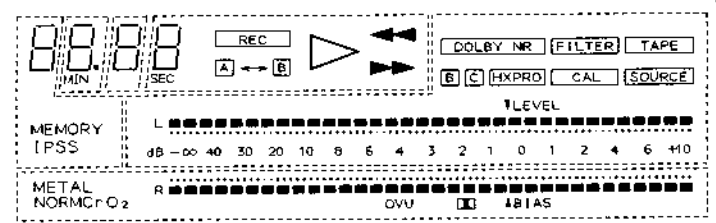

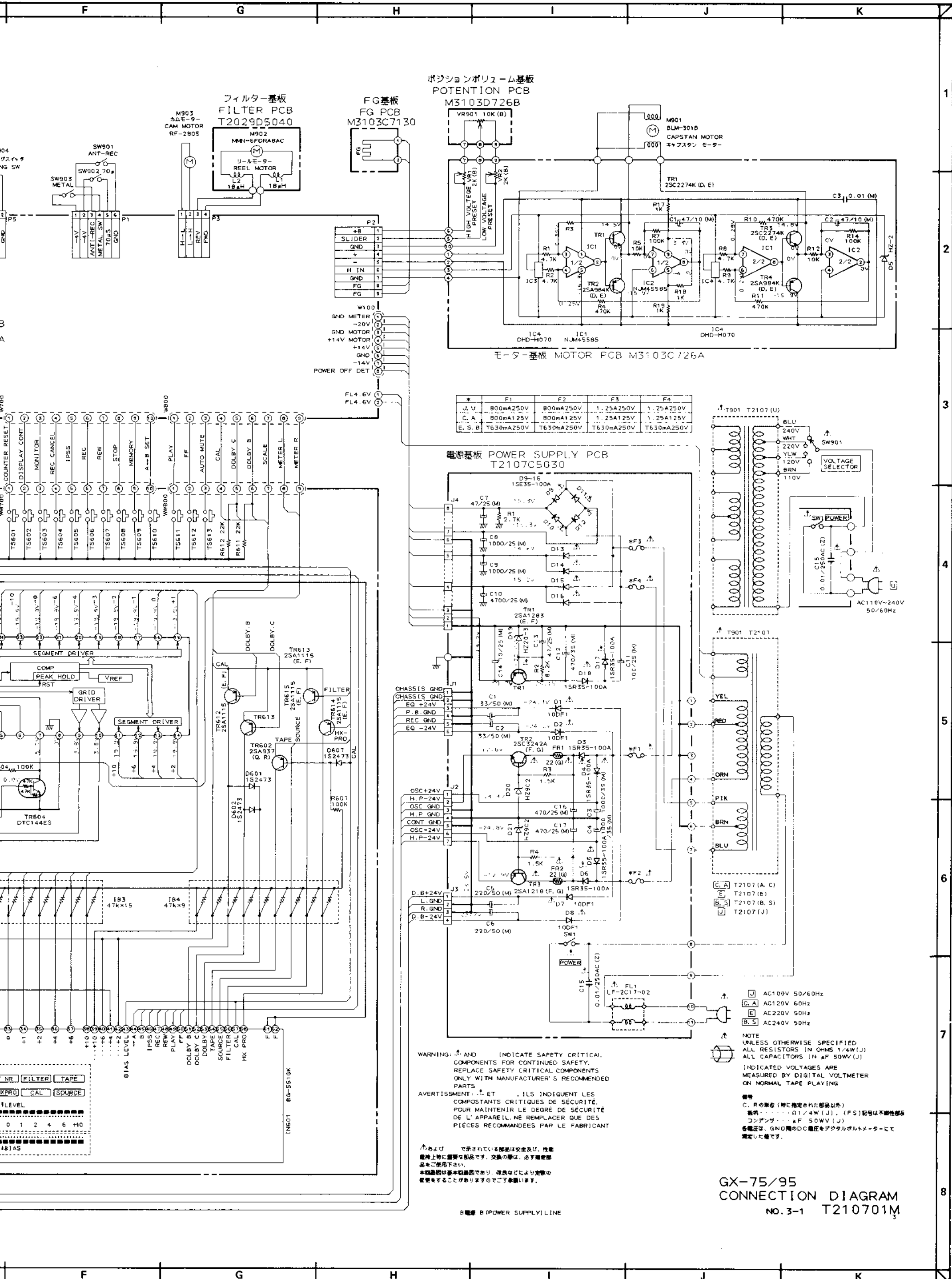

ポジションボリューム基板
POTENTIOM PCB
M3103D726B

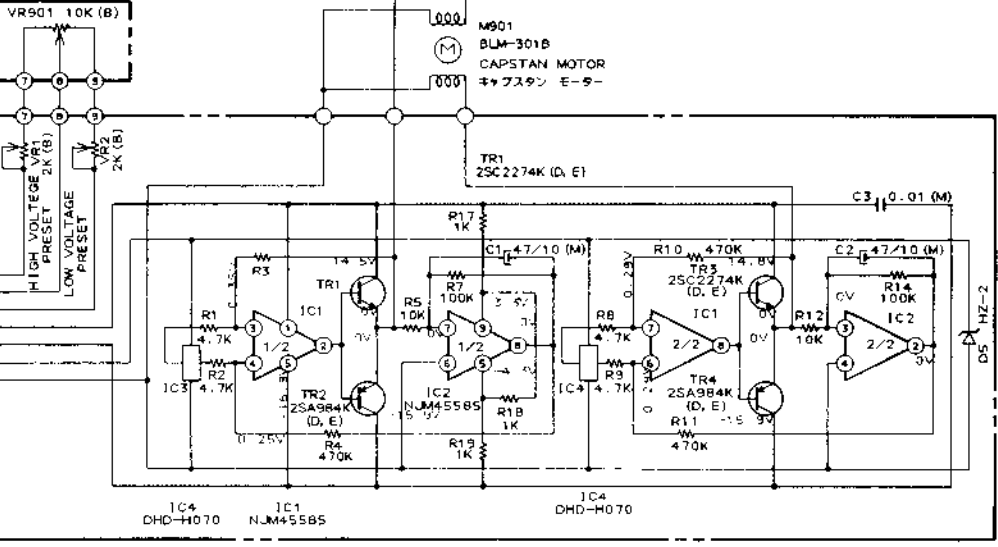

モーター基板 MOTOR PCB M3103C726A

	F1	F2	F3	F4
J. U.	800mA250V	800mA250V	1.25A250V	1.25A250V
C. A.	800mA125V	800mA125V	1.25A125V	1.25A125V
E. S. B.	T630mA250V	T630mA250V	T630mA250V	T630mA250V

電源基板 POWER SUPPLY PCB
T2107C5030

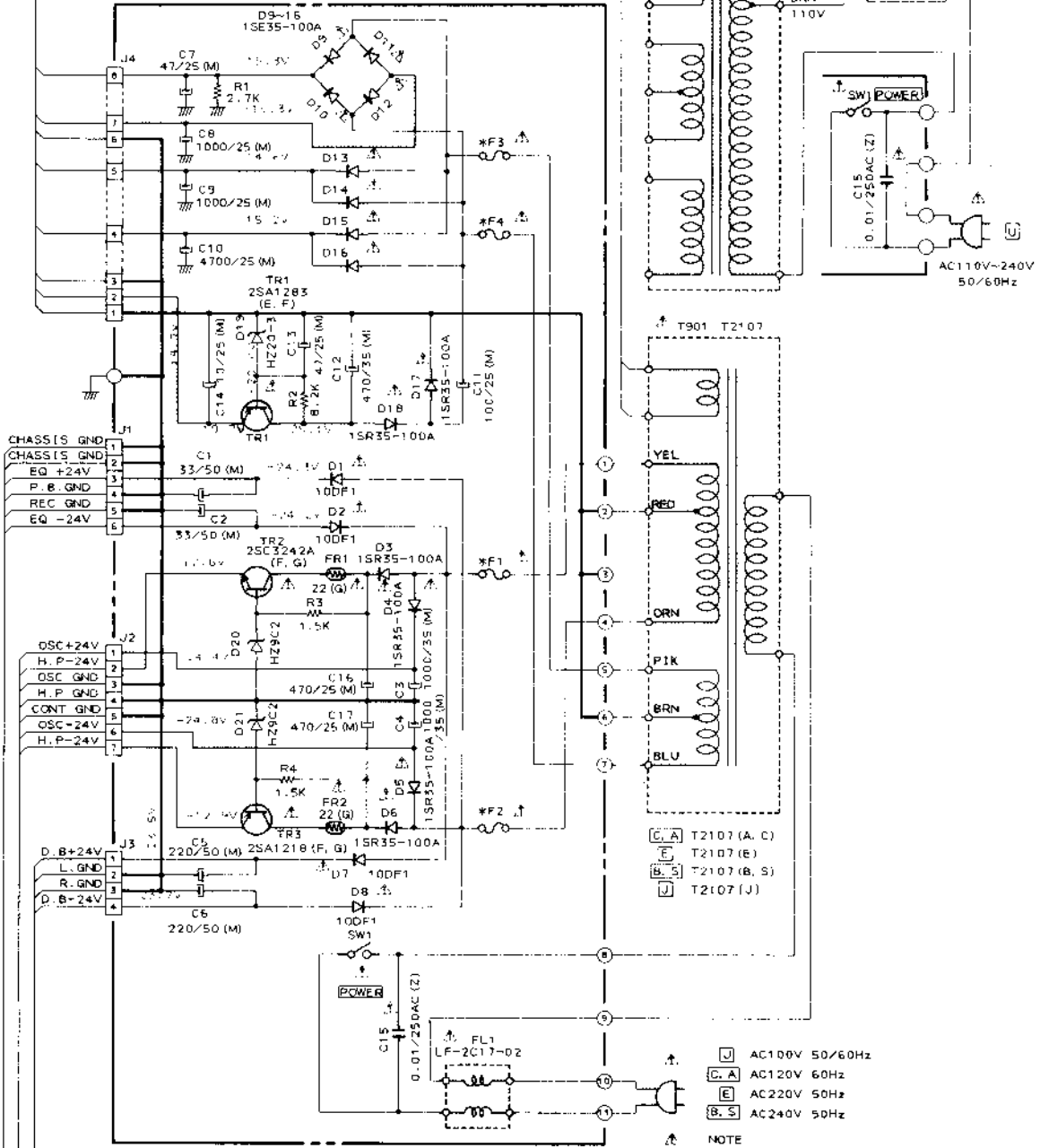

WARNING: AND INDICATE SAFETY CRITICAL COMPONENTS FOR CONTINUED SAFETY. REPLACE SAFETY CRITICAL COMPONENTS ONLY WITH MANUFACTURER'S RECOMMENDED PARTS.

AVERTISSEMENT: ET ILS INDIQUENT LES COMPOSTANTS CRITIQUES DE SÉCURITÉ. POUR MAINTENIR LE DEGRÉ DE SÉCURITÉ DE L'APPAREIL, NE REMPLACER QUE DES PIÈCES RECOMMANDÉES PAR LE FABRICANT.

NOTE: UNLESS OTHERWISE SPECIFIED, ALL RESISTORS IN OHMS 1/4W(J). ALL CAPACITORS IN μF 50WV(J). INDICATED VOLTAGES ARE MEASURED BY DIGITAL VOLTMETER ON NORMAL TAPE PLAYING.

警告: C, Rの単位(特に指定された部品以外)はオーム、抵抗値は1/4W(J)、(PS)記号は不燃性部材、コンデンサは50V、50WV(J)。各電圧は、GND間のDC電圧をデジタルボルトメーターにて測定した値です。

GX-75/95 CONNECTION DIAGRAM NO. 3-1 T210701M

B電源 B (POWER SUPPLY) LINE

※および ※で示されている部品は安全及び、性能維持上特に重要な部品です。交換の際は、必ず指定部品をご利用下さい。本図は基本回路図であり、改良などにより実際の装置と異なる場合がありますのでご了承ください。

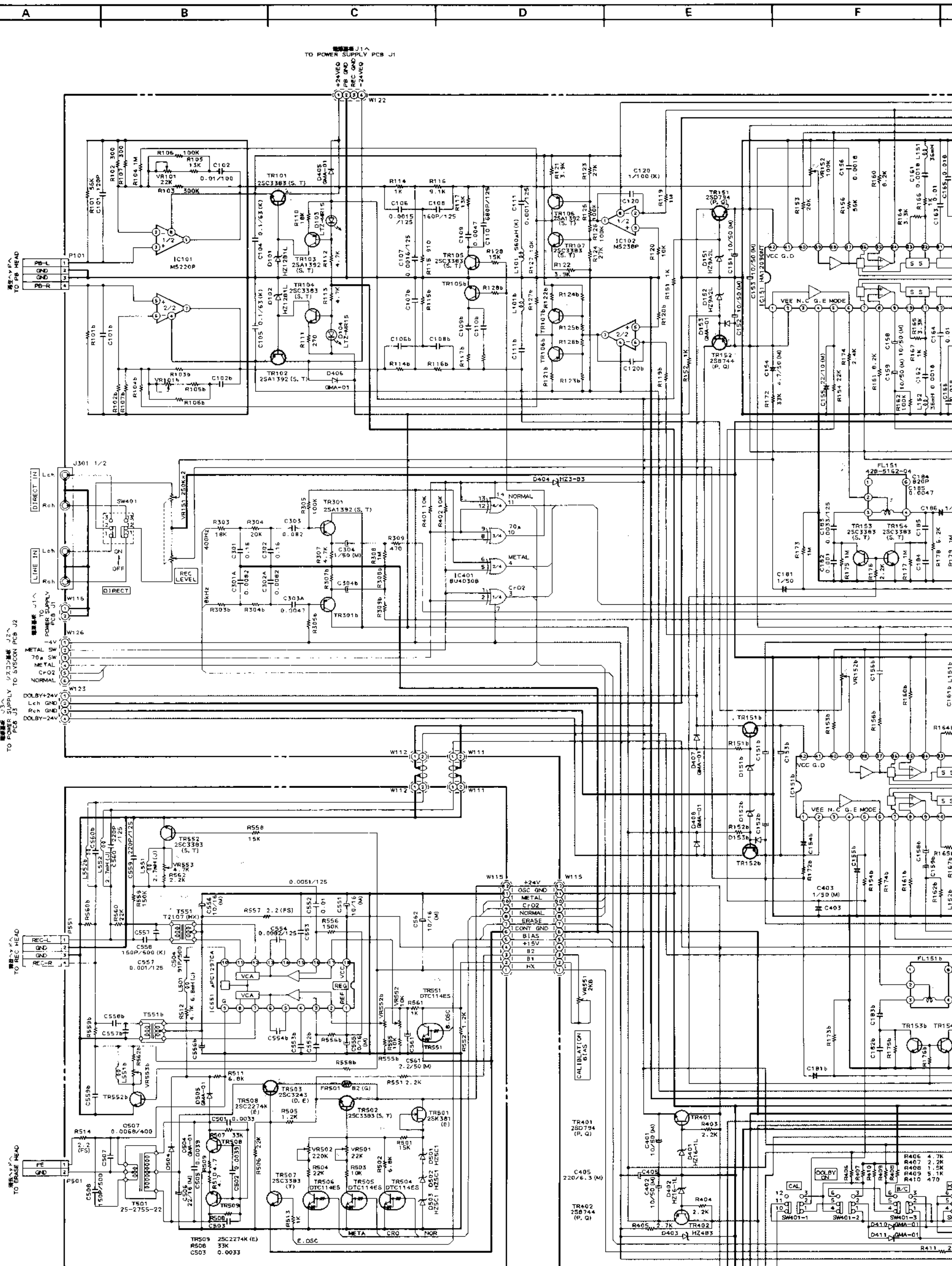

オシレーター基板
OSC PCB T2107A501B

プリアンプ基板
PRE AMP PCB
T2107A501A

TO POWER SUPPLY PCB J2
電線接続 J2



B電源 B (POWER SUPPLY) LINE
 録音線 REC SIGNAL LINE
 再生線 P.B SIGNAL LINE

※この図面は基本回路図であり、現品にてより実際の
 変更をすることがありますのでお祈りいたします。

WARNING: AND INDICATE SAFETY CRITICAL
 COMPONENTS FOR CONTINUED SAFETY.
 REPLACE SAFETY CRITICAL COMPONENTS
 ONLY WITH MANUFACTURER'S RECOMMENDED
 PARTS
AVERTISSEMENT: ET ILS INDIQUENT LES
 COMPOSANTS CRITIQUES DE SÉCURITÉ.
 POUR MAINTENIR LE DEGRÉ DE SÉCURITÉ
 DE L'APPAREIL, NE REMPLACER QUE DES
 PIÈCES RECOMMANDÉES PAR LE FABRICANT

INDICATED VOLTAGE ARE
 MEASURED BY DIGITAL VOLTMETER
 ON NORMAL TAPE PLAYING
 () VOLTAGE ON NORMAL TAPE RECORDING

備考
 C、Rの値は(特に指定された部品以外)
 抵抗値: 0.1/4W(J), (FS)記号は不燃性樹脂
 コンデンサ: 1/50WV(J)
 各種圧は、GND側の0.01μF電圧キリタリメーターにて
 測定した値です。

NOTE
 UNLESS OTHERWISE SPECIFIED
 ALL RESISTORS IN OHMS (1/4W(J))
 ALL CAPACITORS IN μF 50WV(J)

PRE AMP
 SCHEMATIC DIAGRAM
 NO.3-2 T210702M

TO SYS500 PCB J3
 システム基板 J3へ
 TO SYS500 PCB J1
 システム基板 J1へ

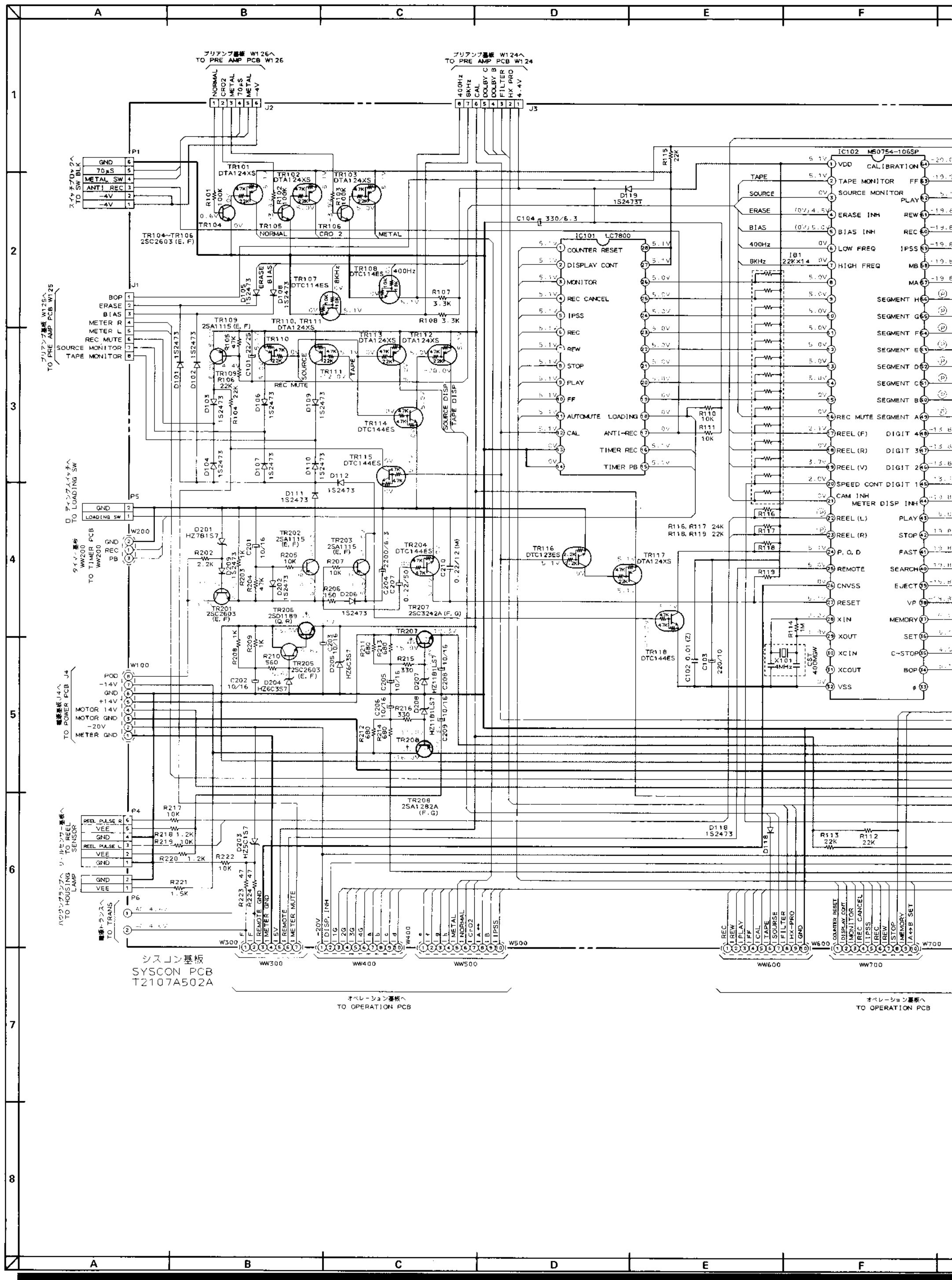

システム基板
SYSCON PCB
T2107A502A

オペレーション基板へ
TO OPERATION PCB

オペレーション基板へ
TO OPERATION PCB

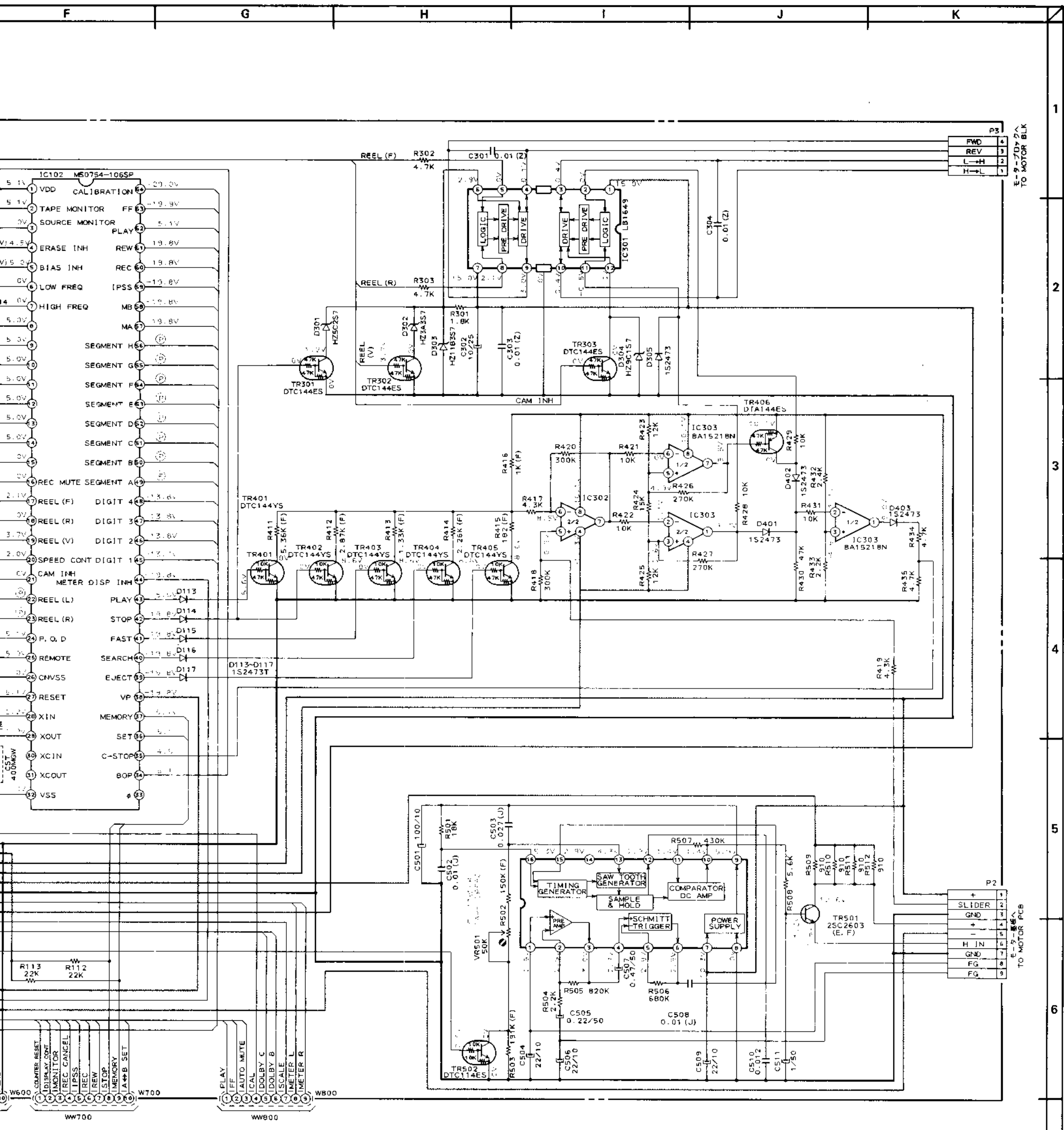

オペレーション基板へ
TO OPERATION PCB

B (電源) ライン
各端子は、GND間のDC電圧をデジタルボルTMETERにて測定した値です。

B (POWER SUPPLY) LINE
INDICATED VOLTAGES ARE MEASURED BY DIGITAL VOLT METER ON NORMAL TAPE PLAYING

備考
C, Rの単位 (特に指定された部品以外)
抵抗: Ω, 1/4W (J), (FS) 記号は耐燃性部品
コンデンサ: μF, 50WV (M)

NOTE
UNLESS OTHERWISE SPECIFIED
ALL RESISTORS IN OHMS 1/4W (J)
ALL CAPACITORS IN μF 50WV (M)

△および◎で示されている部品は安全及び、性能維持上特に重要な部品です。交換の際は、必ず指定部品をご使用下さい。
本回路図は基本回路図であり、改良などにより定数の変更をすることがありますのでご了承ください。

WARNING: △ AND ◎ INDICATE SAFETY CRITICAL COMPONENTS FOR CONTINUED SAFETY. REPLACE SAFETY CRITICAL COMPONENTS ONLY WITH MANUFACTURER'S RECOMMENDED PARTS

AVERTISSEMENT: △ ET ◎ ILS INDIQUENT LES COMPOSANTS CRITIQUES DE SÉCURITÉ. POUR MAINTENIR LE DEGRÉ DE SÉCURITÉ DE L'APPAREIL, NE REMPLACER QUE DES PIÈCES RECOMMANDÉES PAR LE FABRICANT

GX-75/95
SYSTEM CONTROL
SCHEMATIC DIAGRAM
NO. 3-3 T210704M

LOCATION OF COMPONENTS

IC		TR 153	C4
IC101	B5	TR 153b	C2
IC102	D6	TR 154	C4
IC151	D3	TR 154b	C2
IC151b	D1	TR201	F1
IC201	E3	TR202	F1
IC202	G1	TR203	F1
IC251	G6	TR204	F1
IC331	G3	TR205	G1
IC401	E1	TR205b	F1
TRANSISTOR		TR301	B2
TR101	D5	TR301b	A2
TR102	D5	TR333	A4
TR103	D5	TR333b	B4
TR104	D5	TR334	A4
TR105	C5	TR334b	B4
TR105b	C5	TR335	A4
TR106	D5	TR335b	B4
TR106b	C5	TR336	G3
TR107	C6	TR336b	F3
TR107b	C5	TR337	G2
TR151	C3	TR337b	F2
TR151b	C1	TR338	G2
TR152	C3	TR338b	F2
TR152b	C2	TR401	D6
		TR402	D6

VR201	CAL LEVEL
VR201b	CAL レベル
VR202	METER SENSE
VR202b	メーター 感度 (0.0V)

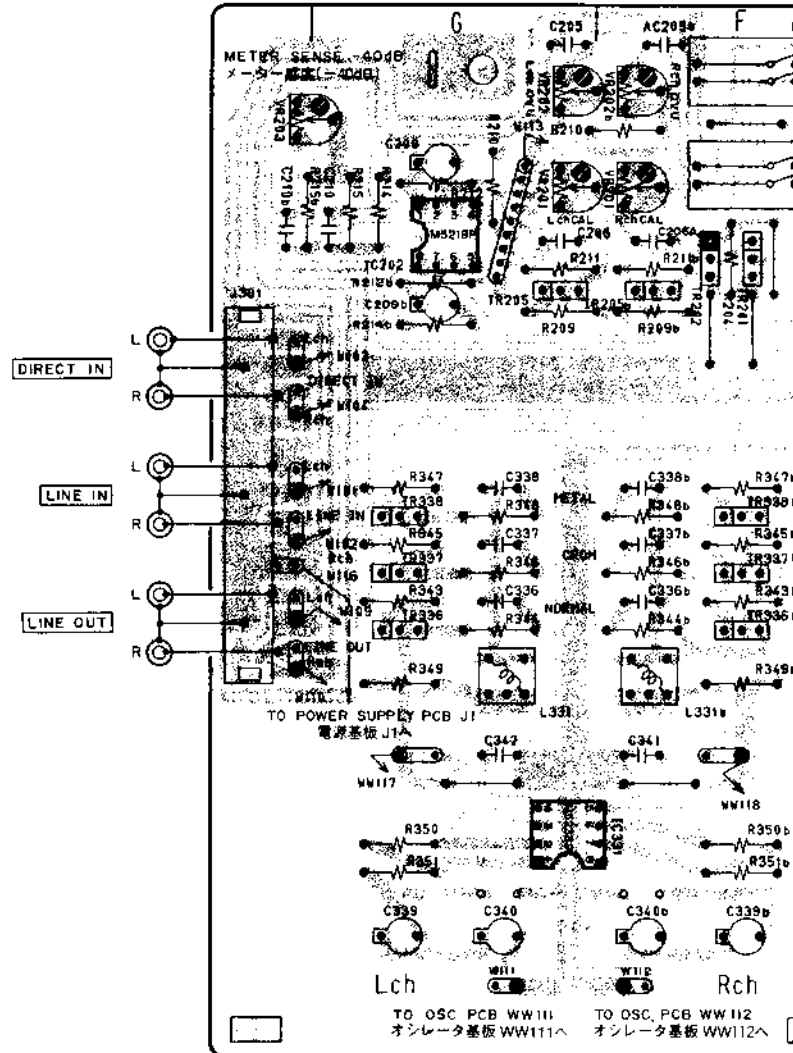

PREAMP PCB T2107A501A
プリアンプ基板

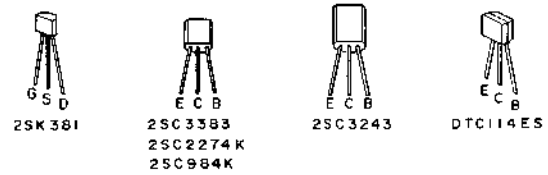

PNP TRANSISTOR
トランジスタ
 NPN TRANSISTOR
トランジスタ

PNP TRANSISTOR
トランジスタ
 NPN TRANSISTOR
トランジスタ

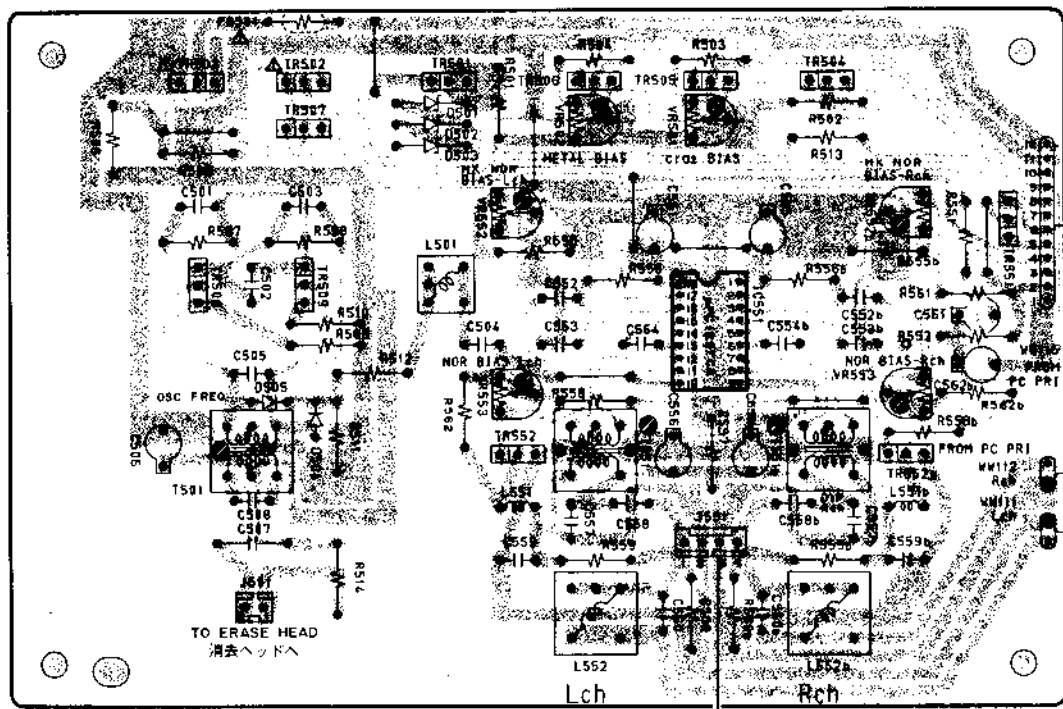
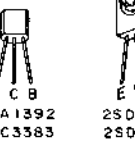

OSC PCB
オシレータ基板
T2107A501B

TO REC HEAD
録音ヘッドへ

TO PRE AMP PCB W114
プリアンプ基板 W114へ

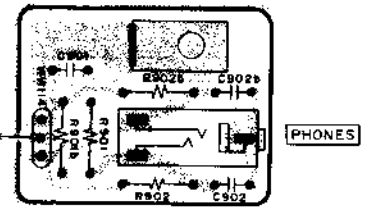

HEAD PHONE PCB
ヘッドホン基板
T2107A 501C

WARNING INDICATES SAFETY CRITICAL COMPONENTS. PLEASE REPLACE SAFETY CRITICAL COMPONENTS ONLY WITH RECOMMENDED PARTS.
 AVERTISSEMENT INDIQUE LES COMPOSANTS CRITIQUES POUR LA SECURITE. NE REMPLACEZ QUE DES PIECES RECOMMENDEES.

注意 点の付された部品は、安全上重要な部品です。交換の際は、指定

- VR201 CAL LEVEL
CALレベル
- VR201b CALレベル
- VR202 METER SENSE
メーター 感度 (0uv)
- VR202b

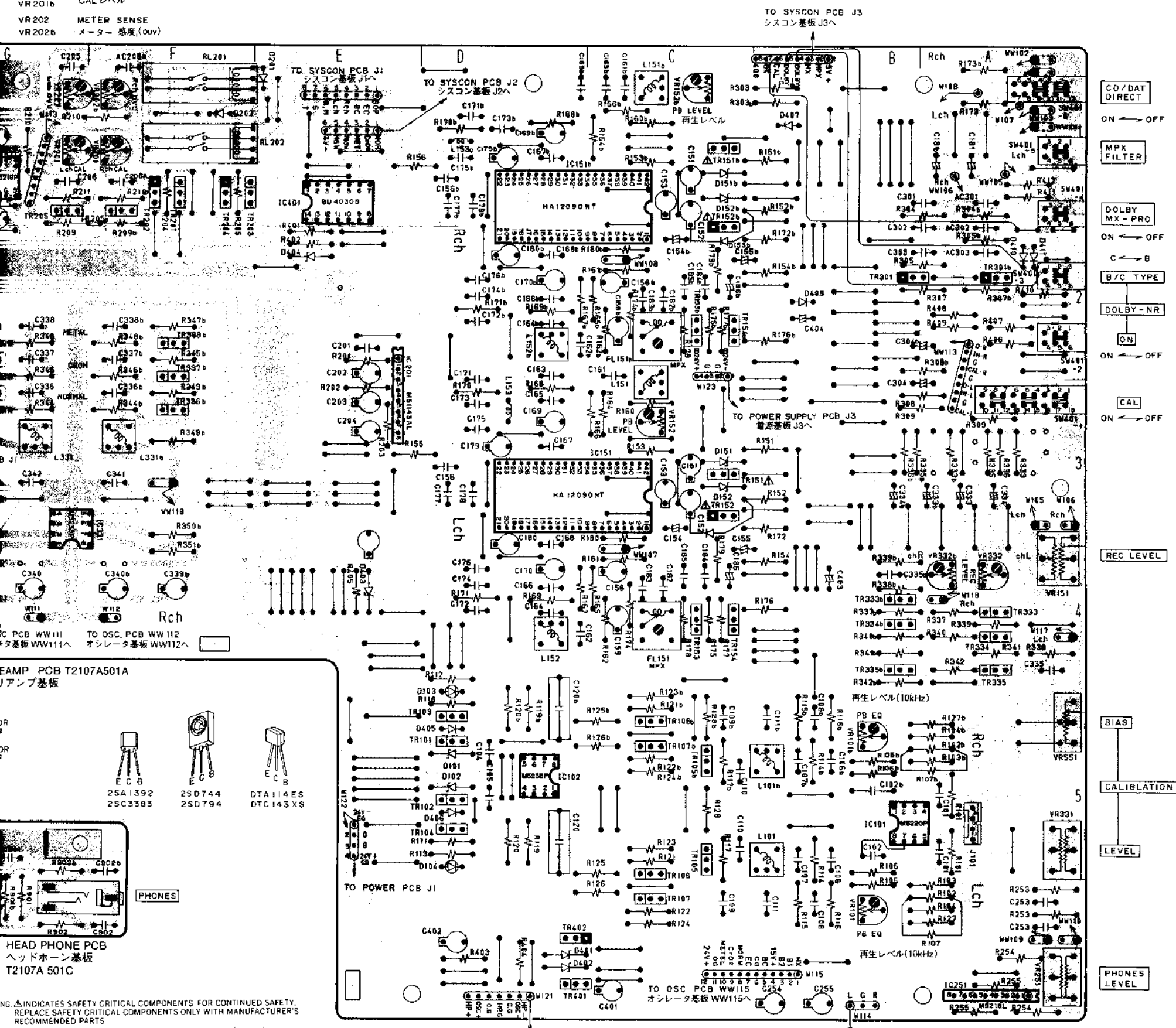

- CD/DAT DIRECT
ON ← OFF
- MPX FILTER
- DOLBY MX-PRO
ON ← OFF
- C ← B
B/C TYPE
- DOLBY-NR
ON ← OFF
- CAL
ON ← OFF

REC LEVEL

BIAS

CALIBRATION

LEVEL

PHONES LEVEL

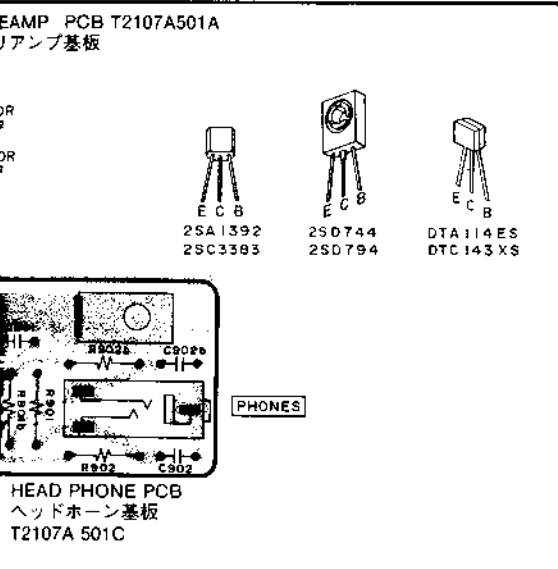

△ INDICATES SAFETY CRITICAL COMPONENTS FOR CONTINUED SAFETY.
REPLACE SAFETY CRITICAL COMPONENTS ONLY WITH MANUFACTURER'S RECOMMENDED PARTS.

△ INDIQUE LES COMPOSANTS CRITIQUES DE SÉCURITÉ.
POUR MAINTENIR LE DEGRÉ DE SÉCURITÉ DE L'APPAREIL,
NE REMPLACER QUE DES PIÈCES RECOMMANDÉES PAR LE FABRICANT

△ 安全上の付帯品は、安全上重要部品です。交換の際は、指定部品以外は使用しないでください。

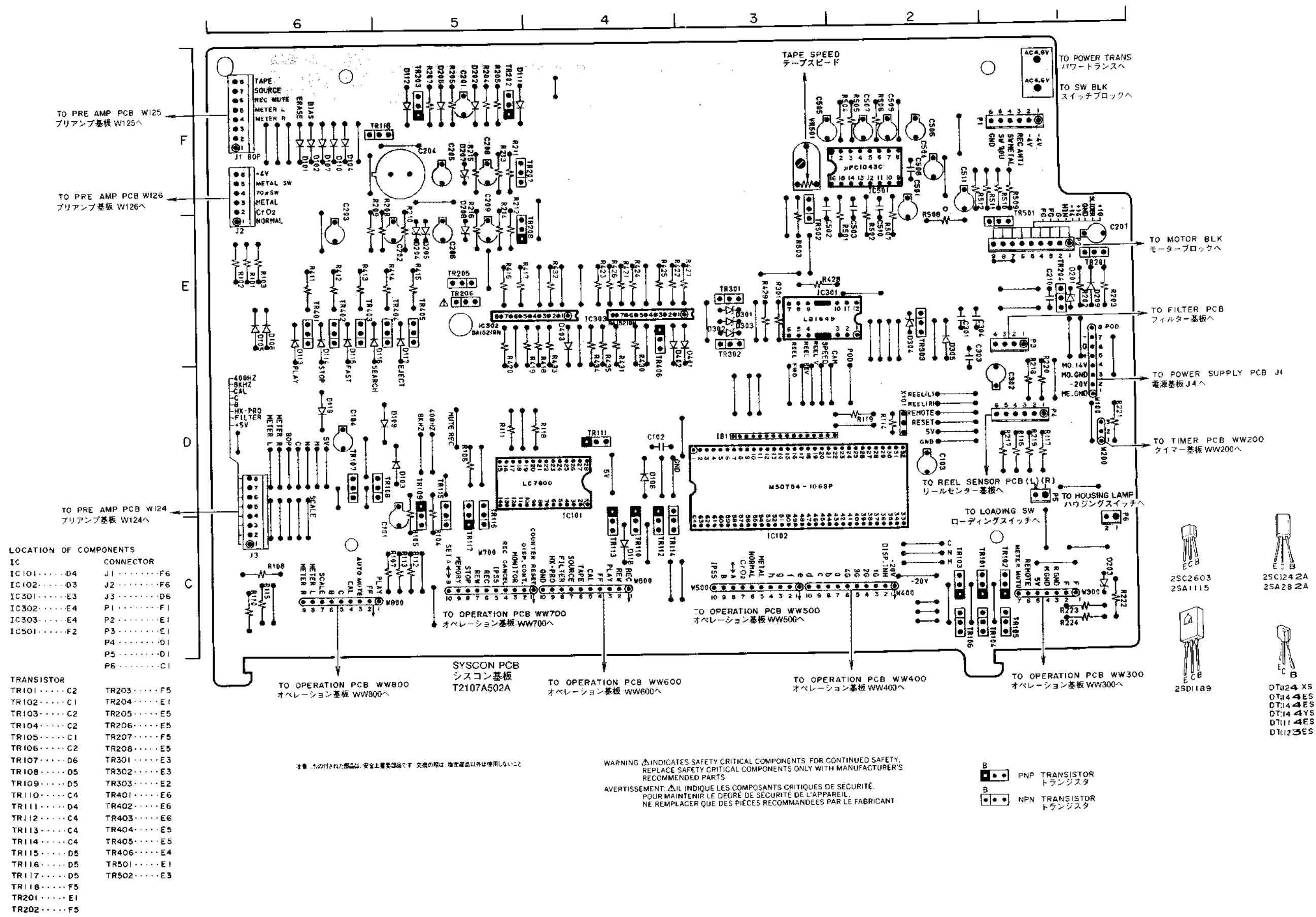

LOCATION OF COMPONENTS

IC	CONNECTOR
IC101.....D4	J1.....F6
IC102.....D3	J2.....F6
IC301.....E3	J3.....D6
IC302.....E4	P1.....F1
IC303.....E4	P2.....E1
IC501.....F2	P3.....E1
	P4.....D1
	P5.....D1
	P6.....C1

TRANSISTOR	
TR101.....C2	TR203.....F5
TR102.....C1	TR204.....E1
TR103.....C2	TR205.....E5
TR104.....C2	TR206.....E5
TR105.....C1	TR207.....F5
TR106.....C2	TR208.....E5
TR107.....D6	TR301.....E3
TR108.....D5	TR302.....E3
TR109.....D5	TR303.....E2
TR110.....C4	TR401.....E6
TR111.....D4	TR402.....E6
TR112.....C4	TR403.....E6
TR113.....C4	TR404.....E5
TR114.....C4	TR405.....E5
TR115.....D5	TR406.....E4
TR116.....D5	TR501.....E1
TR117.....D5	TR502.....E3
TR118.....F5	
TR201.....F5	
TR202.....F5	

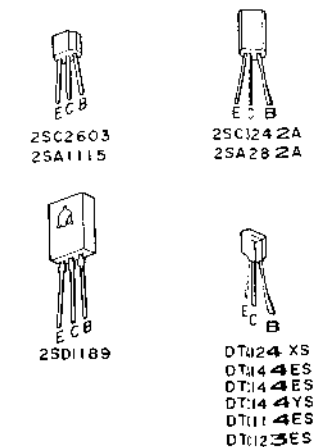

注意 点の付いた部品は、安全上重要部品です。交換の際は、指定部品以外は使用しないこと

WARNING Δ INDICATES SAFETY CRITICAL COMPONENTS. FOR CONTINUED SAFETY, REPLACE SAFETY CRITICAL COMPONENTS ONLY WITH MANUFACTURER'S RECOMMENDED PARTS.
 AVERTISSEMENT Δ IL INDIQUE LES COMPOSANTS CRITIQUES DE SÉCURITÉ. POUR MAINTENIR LE DEGRÉ DE SÉCURITÉ DE L'APPAREIL, NE REMPLACER QUE DES PIÈCES RECOMMANDÉES PAR LE FABRICANT

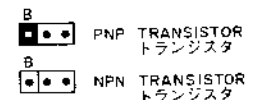

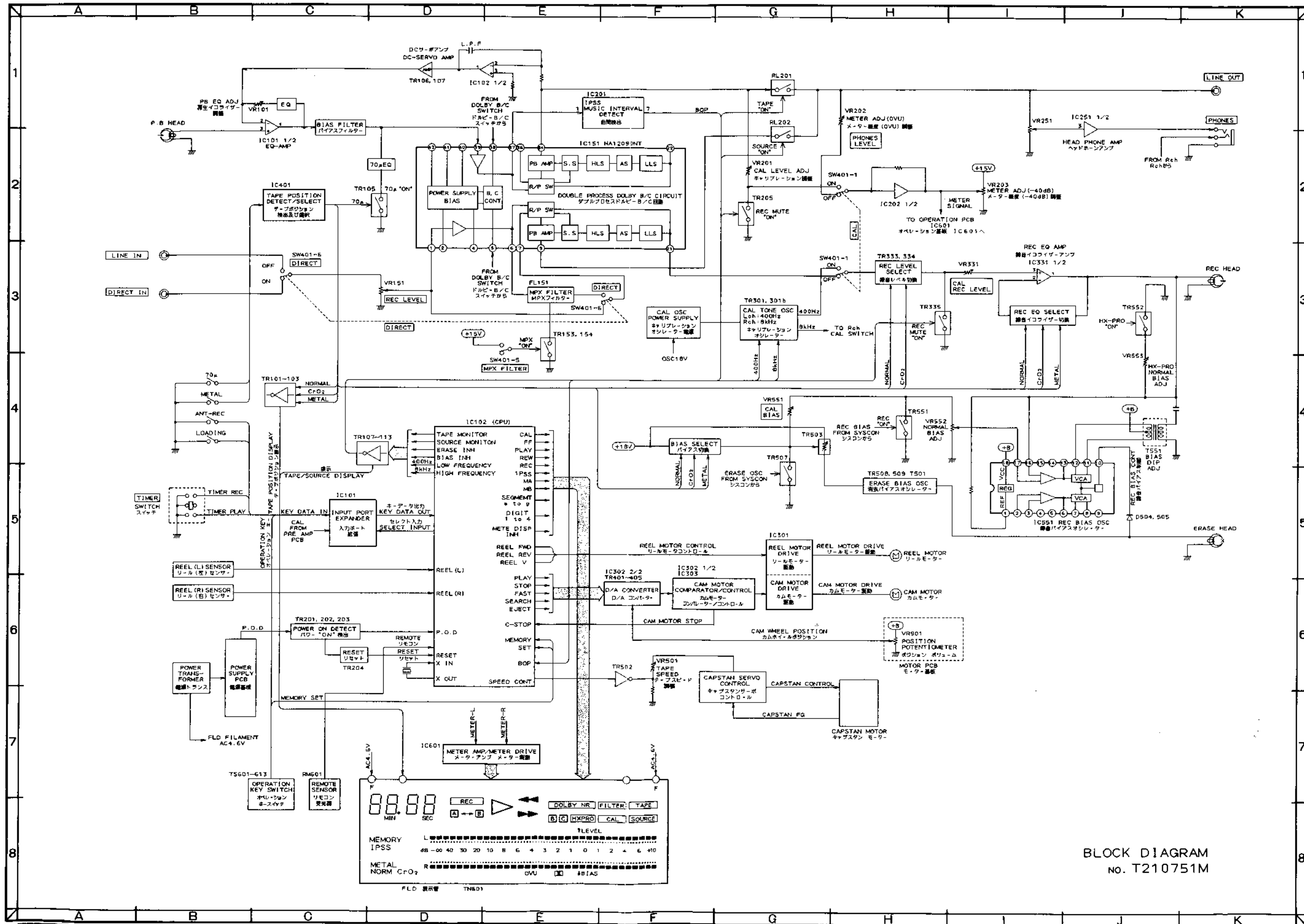

BLOCK DIAGRAM
no. T210751M

INDEX

Part No.	Ref. No.	Part No.	Ref. No.	Part No.	Ref. No.	Part No.	Ref. No.
ET-349081	5-TR337	ET-382952J	8-TR116	SM-365756C	13-34	ZW-306464	2-99
ET-349081	5-TR338	ET-384905J	1-66	SP-336163B	2-103	ZW-309295	3-19
ET-349081	6-TR502	ET-384905J	9-TR603	SP-384060J	13-39	ZW-316800	2-92
ET-349081	6-TR552	ET-384905J	9-TR608	SP-384072J	13-31	ZW-329422	2-55
ET-349883	1-88	ET-384905J	9-TR609	SP-384092J	13-8A	ZW-329422	2-100
ET-349883	6-TR503	EV-330531	8-VR501	SP-384094J	13-8B	ZW-330073	2-30
ET-349979	1-92	EV-337052	3-3	SP-384095J	13-8C	ZW-336604	3-9
ET-349979	5-TR151	EV-356576	6-VR553	SP-384097J	13-8D	ZW-356166	2-65
ET-349979	5-TR401	EV-356577	5-VR101	SP-384100J	13-57	ZW-356657	2-47
ET-351123	1-90	EV-356577	5-VR201	SP-384101J	13-62	ZW-356657	2-60
ET-351123	6-TR507	EV-356577	6-VR552	SP-384102J	13-61	ZW-373128	13-56
ET-352726	1-80	EV-356584	6-VR502	SP-385721J	13-21	ZW-376292	13-63
ET-352726	5-TR102	EV-357619	5-VR152	SP-387839J	13-8E	ZW-381644	2-59
ET-352726	5-TR103	EV-357619	5-VR202	SZ-336166	2-106	ZW-618884	2-64
ET-352726	5-TR106	EV-357619	5-VR332	SZ-384061J	13-30	ZW-618884	2-78
ET-352726	5-TR301	EV-358829	6-VR501	SZ-388434J	13-22	ZW-653163	3-7
ET-353067	1-83	EV-358862	5-VR203	TC-336002	3-10		
ET-353067	5-TR152	EV-370008	1-94	TC-336016	3-24		
ET-353067	5-TR402	EV-370008	5-VR551	TC-336027	3-25		
ET-353897	1-70	EV-373388	1-96	TC-336142	2-29		
ET-353897	6-TR504	EV-373388	5-VR251	TC-336146	2-36		
ET-353897	6-TR505	EV-384876J	1-93	TC-336146	2-39		
ET-353897	6-TR506	EV-384876J	5-VR151	TC-336161	2-98		
ET-353897	6-TR551	EV-384877J	1-95	TC-336605	1-103		
ET-353897	8-TR107	EV-384877J	5-VR331	TC-336605	2-20		
ET-353897	8-TR108	EV-464253	12-VR1	TC-B336004A	3-2		
ET-353897	8-TR502	EV-464253	12-VR2	ZG-312946	2-40		
ET-354083	1-91	EW-336923	13-11C	ZG-321534	2-52		
ET-354083	8-TR206	EW-346249	13-11D	ZG-330078	2-33		
ET-354365	1-71	EW-347698	13-11E	ZG-336127	2-72		
ET-354365	8-TR401	EW-373139	13-11B	ZG-336130	2-79		
ET-354365	8-TR402	EW-374894	13-11A	ZG-336140	2-26		
ET-354365	8-TR403	EZ-631945	13-12	ZG-336141	2-28		
ET-354365	8-TR404	HE-372248	1-97	ZG-336157	2-93		
ET-354365	8-TR405	HE-372248	2-81	ZG-336160	2-97		
ET-354414	1-75	HR-H2405A010A	1-98	ZG-336175J1	2-51		
ET-354414	8-TR114	HR-H2405A010A	2-75	ZG-336206	2-63		
ET-354414	8-TR115	HZ-336132	2-87	ZG-336208	2-66		
ET-354414	8-TR118	HZ-343000	2-80	ZG-336615	2-104		
ET-354414	8-TR204	HZ-387920J	2-77	ZG-341970	2-7		
ET-354414	8-TR301	HZ-387921J	2-61	ZG-341972	2-86		
ET-354414	8-TR302	MB-336021	1-100	ZG-387804J	2-109		
ET-354414	8-TR303	MB-336021	3-31	ZS-201407	2-88		
ET-354414	9-TR604	MB-336026	1-99	ZS-201407	2-90		
ET-354414	9-TR606	MB-336026	3-20	ZS-301576	13-16		
ET-354415	1-69	ML-336158	2-95	ZS-305827	13-40		
ET-354415	8-TR406	ML-336159J2	2-96	ZS-341960	13-58		
ET-354841	1-78	MP-336204	1-101	ZS-342002	2-94		
ET-354841	8-TR208	MP-336204	2-58	ZS-345613	2-83		
ET-354841	11-TR3	MP-346329	1-102	ZS-350934	13-10		
ET-356336	1-65	MP-346329	2-45	ZS-352133	13-42		
ET-356336	5-TR202	MR-336019	3-30	ZS-355818	3-11		
ET-356336	5-TR204	MT-305793	2-31	ZS-358936	13-38		
ET-360824	1-74	MV-357208	2-69	ZS-365189	2-84		
ET-360824	9-TR601	MZ-336005	3-4	ZS-376293	13-64		
ET-364093	1-79	MZ-336006	3-8	ZS-376523	13-9		
ET-364093	11-TR1	MZ-353158	3-13	ZS-376523	13-59		
ET-365394	1-87	MZ-353163	13-35	ZS-381482J	13-60		
ET-365394	8-TR207	MZ-384059J	13-46	ZS-387752J	13-24		
ET-365394	11-TR2	SA-384105J	13-41	ZS-432843	3-5		
ET-370311	1-73	SC-726112J	15-1	ZS-477876	2-76		
ET-370311	5-TR201	SE-382435J	13-27	ZS-477876	3-14		
ET-370311	5-TR203	SE-384090J	13-28	ZS-477887	3-23		
ET-370634	1-68	SE-384091J	13-37	ZS-479474	3-16		
ET-370634	9-TR610	SE-384839J	13-32	ZS-479474	3-26		
ET-370634	9-TR611	SE-385722J	13-23	ZS-499331	2-85		
ET-371075	1-67	SK-358066B	13-20	ZS-563444	2-25		
ET-371075	8-TR101	SK-373236B	13-45	ZS-592378	3-29		
ET-371075	8-TR102	SK-373336A	13-51	ZS-608095	2-62		
ET-371075	8-TR103	SK-373336C	13-48	ZS-608095	2-74		
ET-371075	8-TR110	SK-373337A	13-49	ZW-241200	13-66		
ET-371075	8-TR111	SK-373337C	13-47	ZW-270088	2-8		
ET-371075	8-TR112	SK-373337E	13-50	ZW-270088	2-43		
ET-371075	8-TR113	SK-373337G	13-52	ZW-270088	2-48		
ET-371075	8-TR117	SK-381051J	13-55	ZW-270088	2-50		
ET-375780	1-76	SK-384075J	13-29	ZW-270088	2-54		
ET-375780	6-TR501	SK-384077J	13-36	ZW-270088	2-68		
ET-381683J	1-63	SK-384079J	13-33	ZW-305546	2-46		
ET-381683J	9-RM601	SK-384083J	13-53	ZW-305547	2-91		
ET-382952J	1-72	SK-384088J	13-54	ZW-306464	2-56		

ABBREVIATIONS FOR SERVICE MANUAL (CASSETTE)

Abbreviation	Explanation	Abbreviation	Explanation
AC	Alternating Current	MICOM	MicroCOMputer
A/D	Analog/Digital	MIN	MINute
AF	Auto Fader	MML	Maximum Modulation Level
A.M	Auto Mute	MOL	Maximum Output Level
AMP	AMPLifier	MPX	Multi Plex
AR	Anti Recording	NC	Not Connected (No Connection)
AT BIAS	Auto Tuning BIAS	NFB	Negative Feed Back
ATT	ATTenuator	NORM	NORMAL
BAL	BALance	NR	Noise Reduction
BEF	Band Elimination Filter	OSC	OSCillator (OSCillation)
BSS	Blank Search System	P	Pulse
BSPS	Blank Skip Play System	PB	Play Back
CAP M	CAPsTan Motor	QMSS	Quick Memory Search System
CH	CHannel	QR	Quick Reverse
COMP	COMParator	R CH	Right CHannel
CONT	CONTinuance	REC	RECord (RECording)
CRLP	Computer Recording Level Processing	REV	REVerse
CS	Chip Select	ROT	ROTation
D/A	Digital/Analog	REW	REWind
DC	Direct Current	SEC	SECond
DET	DETECTOR	SELE	SELEctor
DISCRI	DISCRIminator	SENS	SENSitivity
DUB	DUBbing	SEPP	Single Ended Push Pull
EQ	EQUALizer	SIG	SIGnal
FF(or F.FWD)	Fast Forward	SPECT	SPECTrum
FLD	FLuorescent Display	STD	STanDard
FREQ	FREQuency	SW	SWitch
FWD	ForWard	SYSCON	SYStem CONTROL
GND	GrouND	TP	Test Point
H	High	TRIG	TRIGa
HPF	High Pass Filter	VCA	Voltage Control Attenuator
IND	INDicator	VOL	VOLUME
IPLS	Instant Program Location System	VOLT	VOLTage
L	Low	VR	Variable Resistor
L CH	Left CHannel	X'TAL	cysTAL
LED	Light Emitting Diode	X1	Normal speed
MEMO	MEMOry	X2	Dubble speed

AKAI ELECTRIC CO., LTD.

12-14, 2-Chome, Higashi-Kojiya, Ohta-Ku, Tokyo, Japan

SERVICE DEPARTMENT TEL: Tokyo(745)9884 TOKYO TELEX: J26261

Printed No. 880920-A1-2300

Printed Date: October 26, 1988

350 Printed in Japan