

AM-A102  
AM-A202  
AM-A302  
AM-A402

# AKAI SERVICE MANUAL

For Service Manuals Contact  
MAURITRON TECHNICAL SERVICES  
8 Cherry Tree Rd, Chinnor  
Oxon OX9 4QY  
Tel:- 01844-351694 Fax:- 01844-352554  
Email:- enquiries@mauritron.co.uk

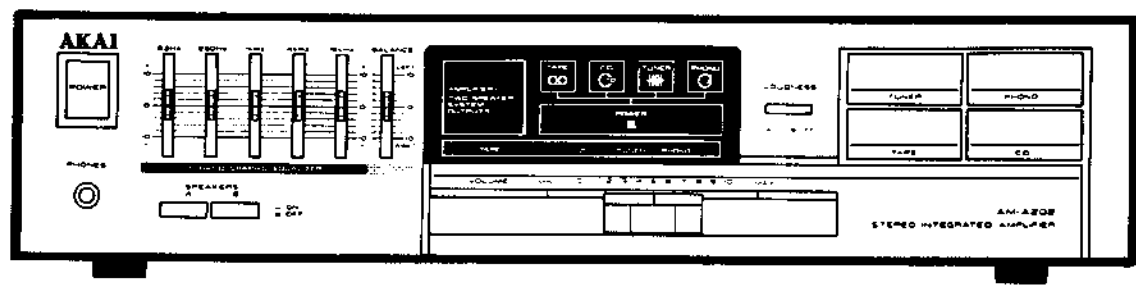

MODEL AM-A202

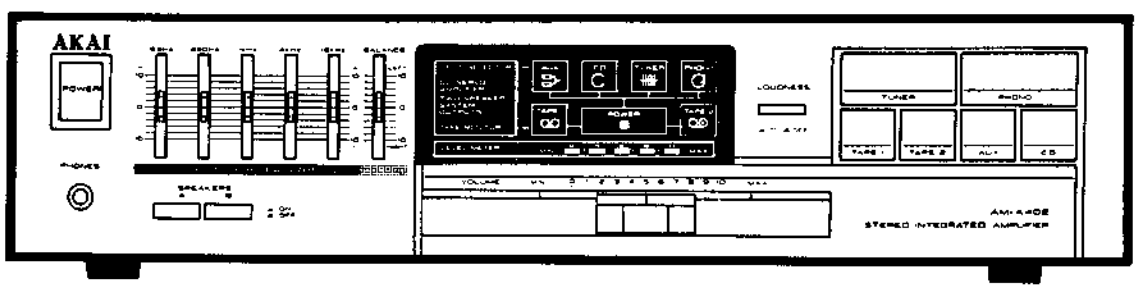

MODEL AM-A402

## STEREO INTEGRATED AMPLIFIER

- MODEL **AM-A102**
- MODEL **AM-A202**
- MODEL **AM-A302**
- MODEL **AM-A402**

# SAFETY INSTRUCTIONS

## PRECAUTIONS DURING SERVICING

1. Parts identified by the  $\Delta$  symbol parts are critical for safety. Replace only with parts number specified.
2. In addition to safety, other parts and assemblies are specified for conformance with such regulations as those applying to spurious radiation. These must also be replaced only with specified replacements.  
Examples: RF converters, tuner units, antenna selector switches, RF cables, noise blocking capacitors, noise blocking filters, etc.
3. Use specified internal wiring. Note especially:
  - 1) Wires covered with PVC tubing
  - 2) Double insulated wires
  - 3) High voltage leads
4. Use specified insulating materials for hazardous live parts. Note especially:
  - 1) Insulation Tape
  - 2) PVC tubing
  - 3) Spacers (Insulating Barriers)
  - 4) Insulation sheets for transistors
  - 5) Plastic screws for fixing microswitch (especially in turntable)
5. When replacing AC primary side components (transformers, power cords, noise blocking capacitors, etc.), wrap ends of wires securely about the terminals before soldering.

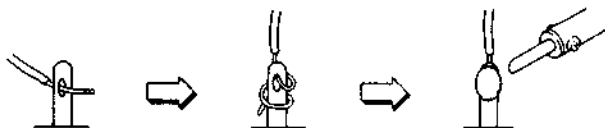

6. Observe that wires do not contact heat producing parts (heatsinks, oxide metal film resistors, fusible resistors, etc.).

7. Check that replaced wires do not contact sharp edged or pointed parts.
8. Also check areas surrounding repaired locations.
9. Use care that foreign objects (screws, solder droplets, etc.) do not remain inside the set.

## SAFETY CHECK AFTER SERVICING

Confirm the specified insulation resistance between power cord plug prongs and externally exposed parts of the set is greater than 10 M ohms, but for equipment with external antenna terminals (tuner, receiver, etc.) and is intended for [C] or [A], specified insulation resistance should be headphone jacks, line-in-out jacks etc. more than 2.2 M ohms (ground terminals, microphone jacks).

For Service Manuals Contact  
MAURITRON TECHNICAL SERVICES  
8 Cherry Tree Rd, Chinnor  
Oxon OX9 4QY  
Tel: 01844-351694 Fax: 01844-352554  
Email: enquiries@mauritron.co.uk

## INFORMATION

### SYMBOLS FOR PRIMARY DESTINATION

Alphabet indicates the destination of the units as listed below.

Symbols	Principal Destinations
[A]	USA
[B]	UK
[C]	Canada
[E]	Europe (except UK)
[J]	Japan
[S]	Australia
[V]	W. Germany only
[U]	Universal Area
[Y*]	Custom version

### VOLTAGE CONVERSION ([U] Model only)

Before connecting the power cord, turn the VOLTAGE SELECTOR located on the rear panel with a screwdriver so that the correct voltage is indicated.

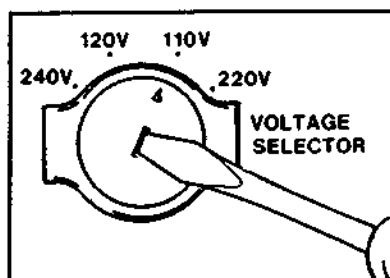

# I. SPECIFICATIONS

## 1-1. Model AM-A202, AM-A102

Model	AM-A202	AM-A102
Power output (8 ohms) Rated by FTC by DIN Music power (Both channels) Power bandwidth (IHF -3 dB, 8 ohms) S/N (IHF-A) PHONO CD, TAPE Residual noise (8 ohms) Channel separation (IHF, 1 kHz) Damping factor (1 kHz, 8 ohms) Speaker impedance A or B A and B	40 W/0.3% 50 W/0.3% 45 W 200 W 10 Hz to 50 kHz (0.5%) 72 dB 92 dB 0.5 mV 60 dB 20 8 to 16 ohms 8 to 16 ohms	25 W/0.3% — 30 W 160 W 10 Hz to 40 kHz (0.5%) 72 dB 92 dB 0.5 mV 60 dB 20 8 to 16 ohms 8 to 16 ohms
Input sensitivity/impedance PHONO CD, TAPE Output level/impedance TAPE Frequency response PHONO (RIAA) CD, TAPE Graphic equalizer Center frequency Control range PHONO max. input level	2.5 mV/47 kohms 150 mV/47 kohms 150 mV/1 kohms ±0.5 dB 5 Hz to 100 kHz (-3 dB) 63 Hz/250 Hz/1 kHz/4 kHz/ 16 kHz ±10 dB 120 mV	2.5 mV/47 kohms 150 mV/47 kohms 150 mV/1 kohms ±0.5 dB 5 Hz to 100 kHz (-3 dB) 63 Hz/250 Hz/1 kHz/4 kHz/ 16 kHz ±10 dB 120 mV
Power requirements	120 V, 60 Hz for USA and Canada 220 V, 50 Hz for Europe except UK 240 V, 50 Hz for UK and Australia 110 V/120 V/220 V/240 V, 50 Hz/60 Hz convertible for other countries	
Dimensions	440 (W) × 100 (H) × 250 (D) mm (17.3 × 3.9 × 9.8 inches)	440 (W) × 100 (H) × 250 (D) mm (17.3 × 3.9 × 9.8 inches)
Weight	5.2 kg (11.5 lbs)	5.8 kg (12.8 lbs)

\* For improvement purposes, specifications and design are subject to change without notice.

## 1-2. Model AM-A402, AM-A302

Model	AM-A402	AM-A302
Power output Rated by FTC by DIN Music power (Both channels) Power bandwidth (IHF -3 dB, 8 ohms) S/N (IHF-A) PHONO CD, TAPE Residual noise (8 ohms) Channel separation (IHF, 1 kHz) Damping factor (1 kHz, 8 ohms) Speaker impedance A or B A and B	8 ohms — 20 Hz to 20 kHz 100 W/0.09% 1 kHz 100 W 430 W 5 Hz to 50 kHz (0.5%) 72 dB 95 dB 0.5 mV 60 dB 45 8 to 16 ohms 16 ohms	8 ohms 20 Hz to 20 kHz 60 W/0.09% 20 Hz to 20 kHz 80 W/0.09% 1 kHz 65 W 320 W 5 Hz to 50 kHz (0.5%) 72 dB 95 dB 0.5 mV 60 dB 45 8 to 16 ohms 16 ohms
Input sensitivity/impedance PHONO CD, TAPE Output level/impedance TAPE Frequency response PHONO (RIAA) CD, TAPE Graphic equalizer Center frequency Control range PHONO max. input level	2.5 mV/47 kohms 150 mV/47 kohms 150 mV/1 kohms ±0.5 dB 5 Hz to 100 kHz (-3 dB) 63 Hz/250 Hz/1 kHz/4 kHz/ 16 kHz ±10 dB 120 mV	2.5 mV/47 kohms 150 mV/47 kohms 150 mV/1 kohms ±0.5 dB 5 Hz to 100 kHz (-3 dB) 63 Hz/250 Hz/1 kHz/4 kHz/ 16 kHz ±10 dB 120 mV
Power requirements	120 V, 60 Hz for USA and Canada 220 V, 50 Hz for Europe except UK 240 V, 50 Hz for UK and Australia 110 V/120 V/220 V/240 V, 50 Hz/60 Hz convertible for other countries	
Dimensions	440 (W) × 100 (H) × 250 (D) mm (17.3 × 3.9 × 9.8 inches)	440 (W) × 100 (H) × 250 (D) mm (17.3 × 3.9 × 9.8 inches)
Weight	7.3 kg (16.1 lbs)	6.8 kg (15.0 lbs)

\* For improvement purposes, specifications and design are subject to change without notice.

## II. DISMANTLING OF UNIT

In case of trouble, etc. necessitating dismantling, please dismantle in the order shown in the photographs.  
Reassemble in reverse order.

### 1. UPPER COVER

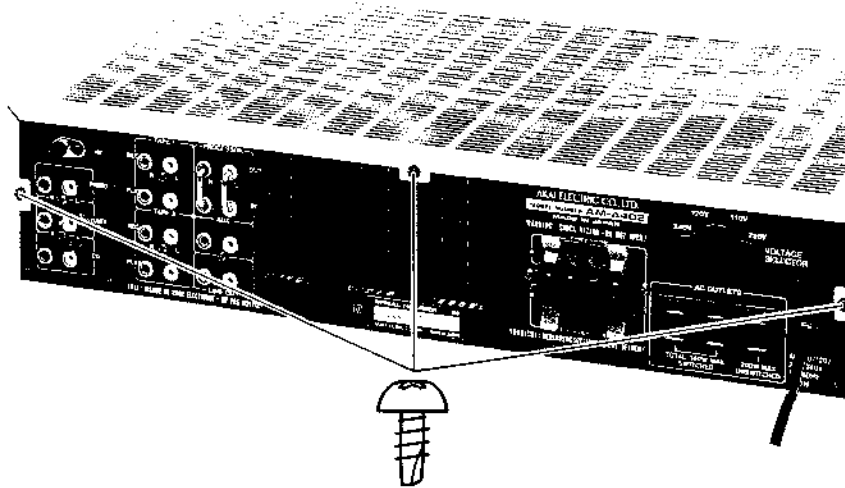

### 2. FRONT PANEL

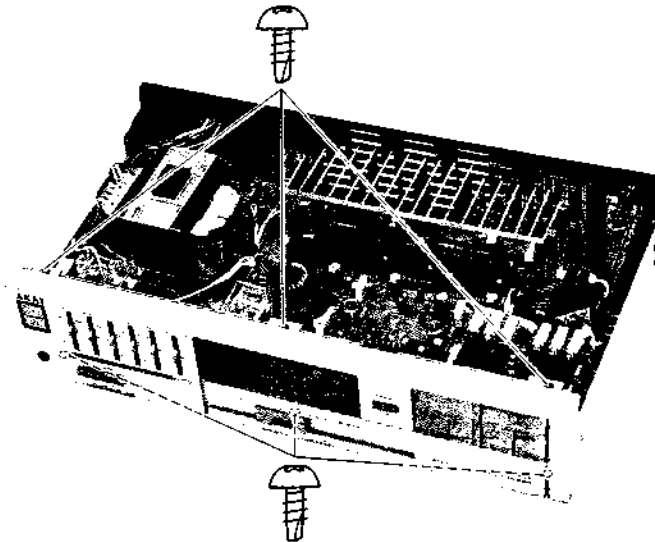

For Service Manuals Contact  
MAURITRON TECHNICAL SERVICES  
8 Cherry Tree Rd, Chinnor  
Oxon OX9 4QY  
Tel: 01844-351694 Fax: 01844-352554  
Email: enquiries@mauritron.co.uk

### III. CONTROLS

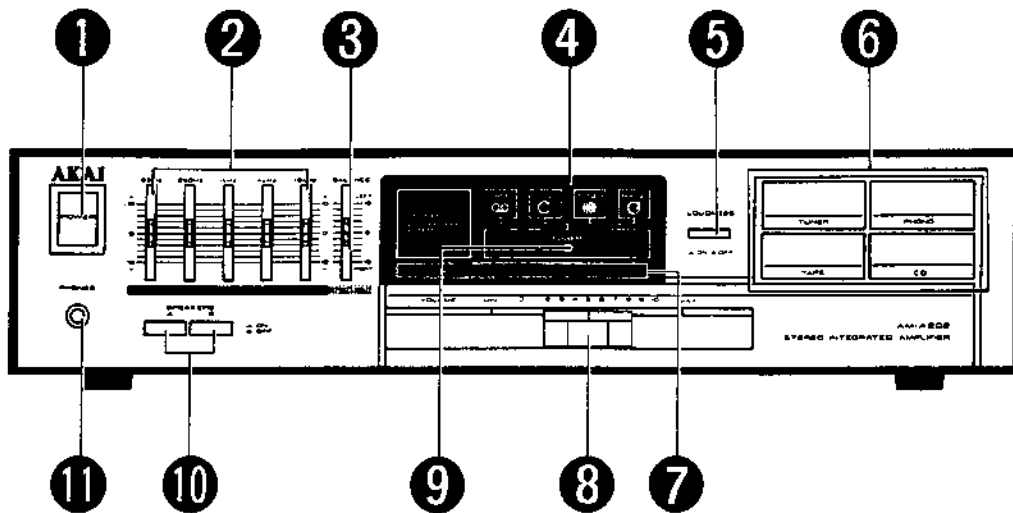

Fig. 3-1 Controls for Models AM-A102, AM-A202

- 1 POWER switch**  
To turn on and off the Akai amplifier.
- 2 GRAPHIC EQUALIZER controls**  
To finely adjust the frequency levels between a range of 63 Hz to 16 kHz, during playback operations.
- 3 BALANCE control**  
To adjust the left and right channel balance.
- 4 INPUT SELECTOR Indicators**  
Shows which input source has been selected.
- 5 LOUDNESS switch**  
For instant compensation of the tone setting at low volume.
- 6 Input source selectors**  
To select audio source you want to listen to.
- 7 TAPE MONITOR indicators**  
Shows which equipment is being monitored.
- 8 VOLUME control**  
To adjust the volume level.
- 9 POWER Indicator**  
Indicates when the power is turned on.
- 10 SPEAKERS Selectors (A and B)**  
To select the speaker system.
- 11 Headphones (PHONES) jack**  
For headphone listening.

For Service Manuals Contact  
**MAURITRON TECHNICAL SERVICES**  
8 Cherry Tree Rd, Chinnor  
Oxon OX9 4QY  
Tel:- 01844-351694 Fax:- 01844-352554  
Email:- enquiries@mauritron.co.uk

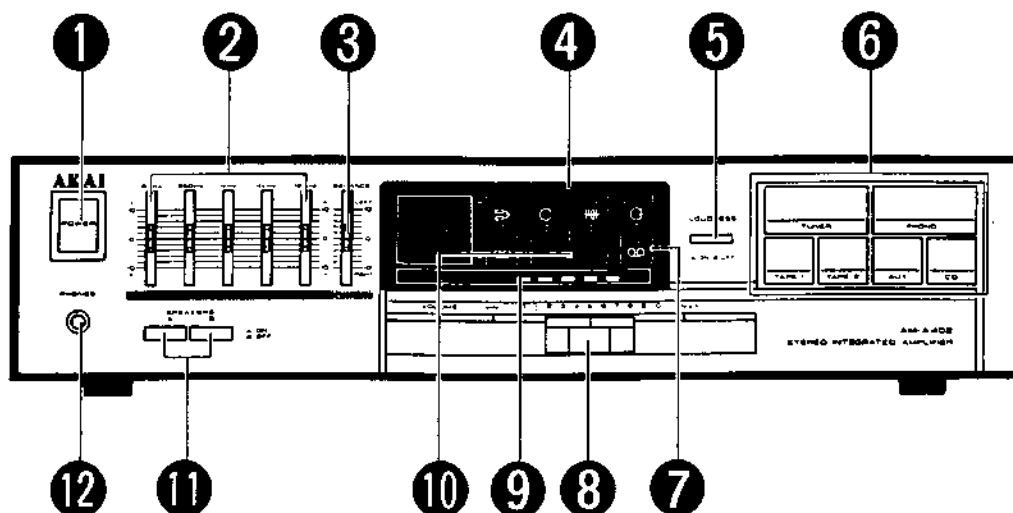

Fig. 3-2 Controls for Models AM-A302, AM-A402

- 1 POWER switch**  
To turn on and off the Akai amplifier.
- 2 GRAPHIC EQUALIZER controls**  
To finely adjust the frequency levels between a range of 63 Hz to 16 kHz, during playback operations.
- 3 BALANCE control**  
To adjust the left and right channel balance.
- 4 INPUT SELECTOR Indicators**  
Shows which input source has been selected.
- 5 LOUDNESS switch**  
For instant compensation of the tone setting at low volume.
- 6 Input source selectors**  
To select audio source you want to listen to.
- 7 TAPE MONITOR indicators**  
Shows which equipment is being monitored.
- 8 VOLUME control**  
To adjust the volume level.
- 9 LED LEVEL meter**  
Indicates both the left and right channel sound volume level.
- 10 POWER Indicator**  
Indicates when the power is turned on.
- 11 SPEAKERS Selectors (A and B)**  
To select the speaker system.
- 12 Headphones (PHONES) jack**  
For headphone listening.

**Protection circuit**

When the Akai amplifier is turned on, no signal will be output to the speakers for a few seconds. This is due to the protection circuit which prevents output of noise when the Akai amplifier is turned on.

The protection circuit also functions during playback to protect the speakers from overloading, and to protect the circuit from damages. When speakers with less than rated impedance are used, the protection circuit will short-circuit the ⊕ and ⊖ speaker cords. Therefore, should the sound be cut during playback:

- 1 Turn off the Akai amplifier.
- 2 Check for and correct the cause.
- 3 Turn on the Akai amplifier.

For Service Manuals Contact  
**MAURITRON TECHNICAL SERVICES**  
 8 Cherry Tree Rd, Chinnor  
 Oxon OX9 4QY  
 Tel: 01844-351694 Fax: 01844-352554  
 Email: enquiries@mauritron.co.uk

# IV. PRINCIPAL PARTS LOCATION

## 4-1. Model AM-A102, AM-A202

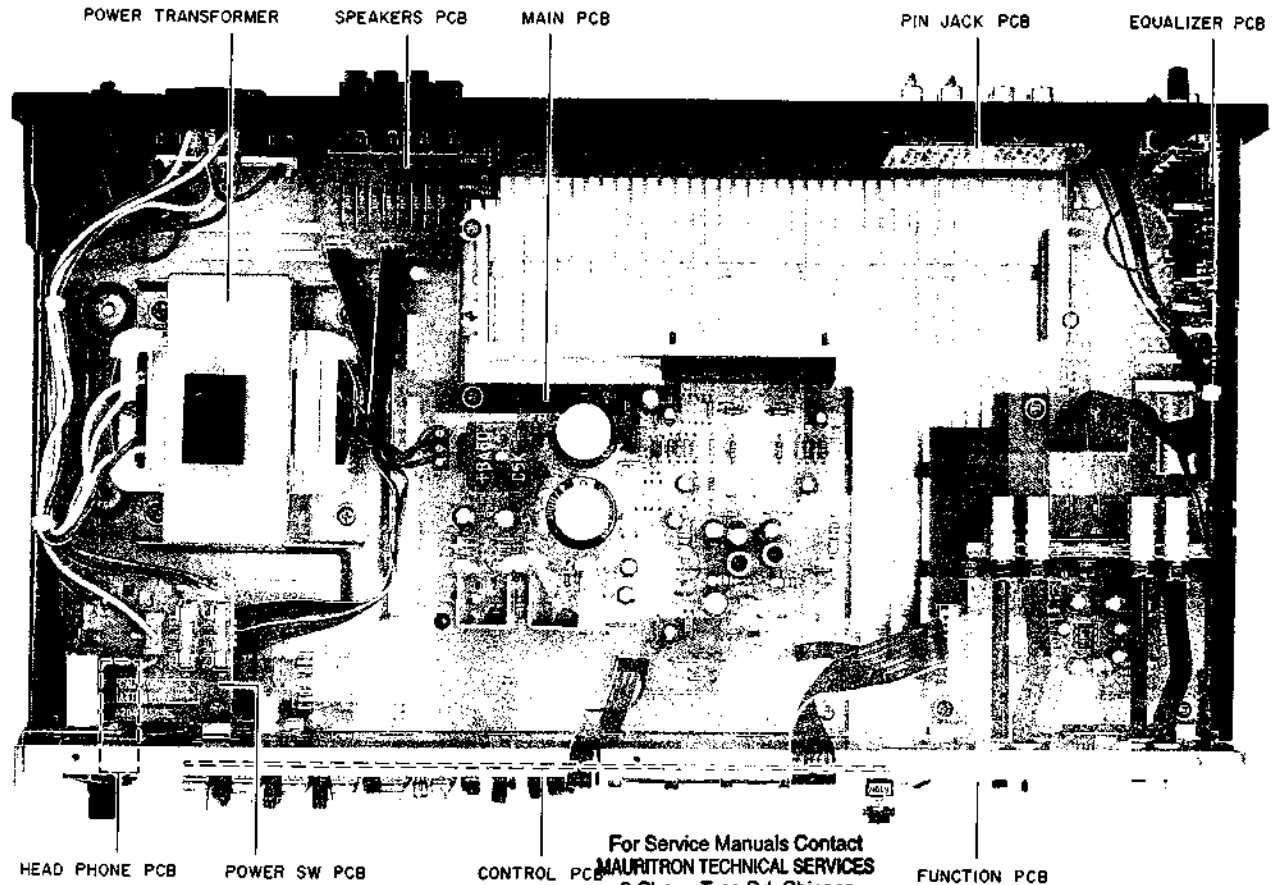

Fig. 4-1

## 4-2. Model AM-A302, AM-A402

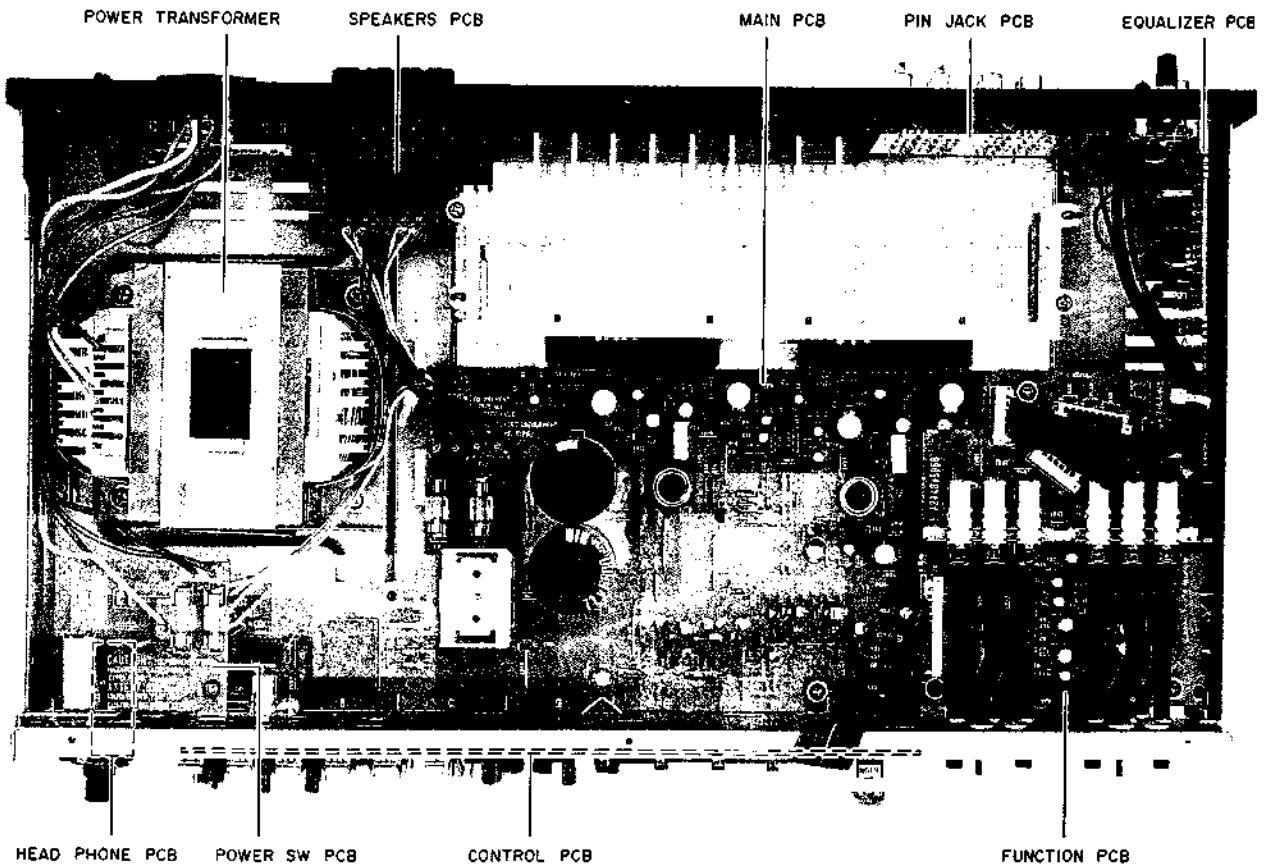

Fig. 4-2

# V. ADJUSTMENT

## 5-1. LEVEL METER SENSITIVITY ADJUSTMENT (AM-A302, AM-A402 Model only)

This adjustment is not necessary if the level meter shows no levels with no signal input.

However if the level meter shows some levels in spite of no signal input, adjust VR8 to the point where the first LED (D1) is extinguished.

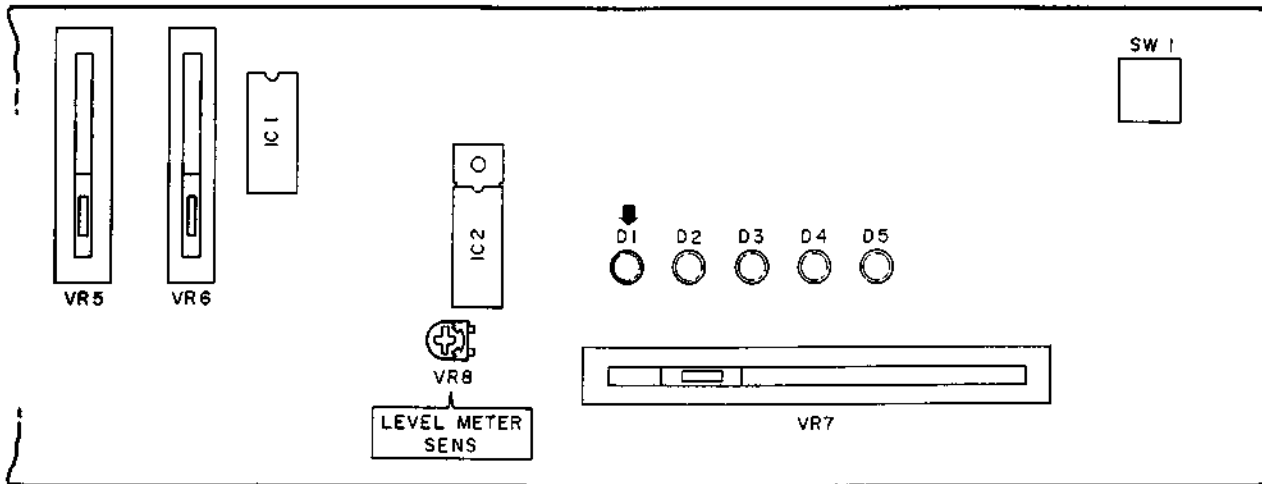

Fig. 5-1 Adjustment point of CONTROL PCB

For Service Manuals Contact  
MAURITRON TECHNICAL SERVICES  
8 Cherry Tree Rd, Chinnor  
Oxon OX9 4QY  
Tel: 01844-351694 Fax: 01844-352554  
Email: enquiries@mauritron.co.uk



# VI. PARTS LIST

## ATTENTION

1. When placing an order for parts, be sure to list Part No., Model No. and the description of each part. Otherwise, the non-delivery of the part or the delivery of a wrong part may result.
2. Please make sure that Part No. is correct when ordering.  
If not, a part different from the one you ordered may be delivered.
3. Since the parts shown in Parts List of Preliminary Service Manual may have been the subject of changes, please use this Parts List for all future reference.

## HOW TO USE THIS PARTS LIST

1. This Parts List lists those parts which are considered necessary for repairs. Other common parts, such as resistors and capacitors, are listed in the "Common List for Service Parts" from which these parts should be selected and stocked.
2. The Recommended Spare Parts List shows those parts in the Parts List which are considered particularly important for service.
3. Parts not shown in the Parts List and "Common List for Service Parts" will not in principle be supplied.
4. How to read the Parts List.

a) Mechanism Block

b) PC Board

### 2. HEAD BASE BLOCK

REF. NO.	PART NO.	DESCRIPTION
2-1x	BH-T2023A320A	HEAD BASE BLOCK
2-2	HP-H2206A010A	HEAD R/P PR4-8FU C
2-3	ZS-477876	PAN20x03STL CMT
2-4	ZS-536488	BID20x08STL CMT
2-5	ZG-402895	SP CS ANGLE ADJUST

- SP (Service Parts) Classification
- A small "x" indicates that this part is not shown in the Photo or Illustration.
- This number corresponds with the individual parts index number in that figure.
- This number corresponds with the Figure Number.

### 6. MAIN PC BOARD

REF. NO.	PART NO.	DESCRIPTION
6-IC1	EI-324536	IC HD14049BP
6-IC2	EI-336801	IC MB8841-564M
6-C1A	EC-338399	C MMY V 223M 250AC [U,E,B,S]
6-C1B	EC-350949	C MMY V 223M 250DC [J]
6-C1C	EC-338397	C MMY V 223M 125AC [C,A]
6-X1	EI-318384	OSC X'TAL NC-18C

- Symbols for primary destination
- [A]: AAL(U.S.A.) [S]: SAA(Australia)
- [B]: BEAB(England) [U]: U/T(Universal Area)
- [C]: CSA(Canada) [V]: VDE(W. Germany)
- [E]: CEE(Europe) [Y]: Custom Version
- [J]: JPN(Japan)
- SP (Service Parts) Classification
- These reference symbols correspond with component symbols in the Schematic Diagrams.

The available PC Board Blocks are listed separately.

5. When Part No. is known, Parts Index at end of Parts List can be used to locate where that part is shown in Parts List by its Reference No. listed at right of Part No.

## WARNING

⚠ INDICATES SAFETY CRITICAL COMPONENTS. FOR CONTINUED SAFETY, REPLACE SAFETY CRITICAL COMPONENTS ONLY WITH MANUFACTURE'S RECOMMENDED PARTS

## AVERTISSEMENT

⚠ IL INDIQUE LES COMPOSANTS CRITIQUES DE SÉCURITÉ. POUR MAINTENIR LE DEGRÉ DE SÉCURITÉ DE L'APPAREIL, NE REMPLACER QUE DES PIÈCES RECOMMANDÉES PAR LE FABRICANT

## RECOMMENDED SPARE PARTS LIST

Because, if the parts listed below are on hand, almost any repair can be accomplished, we suggest that you stock these Recommended Spare Parts Items.

For Service Manuals Contact  
**MAURITRON TECHNICAL SERVICES**  
 8 Cherry Tree Rd, Chinnor  
 Oxon OX9 4QY  
 Tel: 01844-351694 Fax: 01844-352554  
 Email: enquiries@mauritron.co.uk

REF. NO.	PART NO.	DESCRIPTION	REF. NO.	PART NO.	DESCRIPTION
1	BT-352430	△ TRANS POWER AM-A1T-40 [E] (AM-A102)	42	EF-311839	△ FUSE TSC A 250V 1.60A (AM-A102) [U]
2	BT-352431	△ TRANS POWER AM-A1T-50 [B,S] (AM-A102)	43	EF-326639	△ FUSE TSC A 250V 3.15A (AM-A102, 202, 302) [U]
3	BT-352426	△ TRANS POWER AM-A1T-70 [U] (AM-A102)	44	EF-306952	△ FUSE TSC A 250V 4.00A (AM-A202, 402) [U]
4	BT-358520	△ TRANS POWER AM-A201-40 [E] (AM-A202)	45	EF-341260	△ FUSE TSC A 250V 8.00A (AM-A302, 402) [U]
5	BT-358521	△ TRANS POWER AM-A201-50 [B,S] (AM-A202)	46	EF-323080	△ FUSE TSC 125V 3.15A (AM-A202) [C,A]
6	BT-358517	△ TRANS POWER AM-A201-70 [U] (AM-A202)	47	EF-306957	△ FUSE TSC 125V 4.00A (AM-A202) [C,A]
7	N BT-364155	△ TRANS POWER AM-A202-20 [A] (AM-A202)	48	EF-346139	△ FUSE TSC 125V 5.00A (AM-A302) [C,A]
8	N BT-364154	△ TRANS POWER AM-A202-30 [C] (AM-A202)	49	EF-346115	△ FUSE TSC 125V 6.30A (AM-A402) [C,A]
9	BT-358549	△ TRANS POWER AM-A301-40 [E,V] (AM-A302)	50	EF-345658	△ FUSE TSC 125V 8.00A (AM-A302, 402) [C,A]
10	BT-358550	△ TRANS POWER AM-A301-50 [B,S] (AM-A302)	51	N EI-366366	△ IC STK4038II (AM-A302) [U,E,V,B,S]
11	BT-358545	△ TRANS POWER AM-A301-70 [U] (AM-A302)	52	N EI-364646	△ IC STK4044II (AM-A402)
12	N BT-364552	△ TRANS POWER AM-A302T-20 [C,A] (AM-A302)	53	N EI-364549	△ IC STK4042II (AM-A302) [C,A]
13	N BT-364649	△ TRANS POWER AM-A402T-20 [C,A] (AM-A402)	54	EI-352644	△ IC STK4141II (AM-A102)
14	N BT-364650	△ TRANS POWER AM-A402T-40 [E] (AM-A402)	55	EI-358554	△ IC STK4152II (AM-A202) [U,E,V,B,S]
15	N BT-364651	△ TRANS POWER AM-A402T-50 [S] (AM-A402)	56	EI-364171	△ IC STK4171II (AM-A202) [C,A]
16	N BT-364647	△ TRANS POWER AM-A402T-70 [U] (AM-A402)	57	EI-358562	IC LB1416 (AM-A302, 402)
17	N BT-370321	△ TRANS POWER A2047-V [V] (AM-A202)	58	EI-337228	IC M5218L (AM-A302, 402)
18	ED-354114	D LED BR-5507S RED	59	EI-349719	IC M5218P
19	N ED-361885	D LED SLP284C-51U GREEN	60	EI-344764	IC M5218P-21
20	N ED-361803	D LED SLP484C-51 YELLOW	61	EI-355211	IC M5227P
21	ED-200213	D SILICON DBA40C-K15 200/2.6A (AM-A102)	62	EI-354080	IC µPC1237H (AM-A302, 402)
22	ED-200749	D SILICON DBA60-K15 400/6.0A (AM-A302, 402)	63	EQ-337159	△ RELAY POWER G4Z-2282P 2NO 24V (AM-A302, 402)
23	ED-350748	D SILICON DBA60C-K15 (AM-A202)	64	ER-345466	△ R CT P F09 PLATE 5W R22K (AM-A302, 402)
24	ED-348990	D SILICON H DS446 (AM-A302, 402)	65	ER-345751	△ R FUSE ERD2FC S10 1/4W 15R0G
25	ED-301911	D SILICON H DS448	66	ER-328278	△ R FUSE ERD2FC 1/4W 10R0G (AM-A102, 202)
26	ED-306320	D ZENER H HZ15 2 (AM-A102, 202)	67	ER-200746	△ R FUSE ERD2FC 1/4W 1000G
27	ED-313846	D ZENER H HZ16 3 (AM-A302, 402)	68	ES-361970	△ SW PUSH SDDLBI 01-1 (AM-A302, 402)
28	ED-322046	D ZENER H HZ18 1 (AM-A302, 402)	69	ES-337902	△ SW PUSH SDDL1P 01-1 (AM-A102, 202)
29	ED-329056	D ZENER H HZ22 2 (AM-A102, 202)	70	ES-349070	△ SW SELECTOR YKSI11-0002 02-4 [U]
30	ED-346627	D ZENER H HZ33 2 (AM-A302, 402)	71	ES-358556	SW PUSH ESB-621519 2 THROW (AM-A302, 402)
31	EF-359007	△ FUSE BET T 1.25A 250V (AM-A102, 202) [B]	72	ES-359963	SW PUSH ESB-621566 2 THROW (AM-A102, 202)
32	EF-355398	△ FUSE BET T 2.00A 250V (AM-A302) [B]	73	ES-358537	SW PUSH ESB-62968 4 THROW (AM-A102, 202)
33	EF-364518	△ FUSE BET T 2.50A 250V (AM-A102) [B]	74	ES-358564	SW PUSH ESB-62969 6 THROW (AM-A302, 402)
34	EF-359225	△ FUSE BET T 3.15A 250V (AM-A202) [B]	75	N ES-364176	SW PUSH SPPH11 2-02-02N
35	EF-355399	△ FUSE BET T 5.00A 250V (AM-A302) [B]	76	ET-347026	△ TR 2SB507HP E,F (AM-A302, 402)
36	EF-602550	△ FUSE SEMKO T 1.25A 250V (AM-A102, 202) [E,V,S]	77	ET-344176	△ TR 2SD313HP F (AM-A302, 402)
37	EF-601301	△ FUSE SEMKO T 2.00A 250V (AM-A302) [E,V,S]	78	ET-363953	TR DTA114TS (AM-A102, 202)
38	EF-623125	△ FUSE SEMKO T 2.50A 250V (AM-A102) [E,S]	79	ET-353899	TR 2SA1317 S,T,U (AM-A302, 402)
39	EF-691007	△ FUSE SEMKO T 3.15A 250V (AM-A202, 402) [E,S,V]	80	ET-305463	TR 2SA970 GR,BL (AM-A302, 402)
40	EF-249851	△ FUSE SEMKO T 5.00A 250V (AM-A302) [E,V,S]	81	ET-322598	TR 2SB632K E,F (AM-A102, 202)
41	EF-242605	△ FUSE SEMKO T 6.30A 250V (AM-A402) [E,S]	82	ET-307195	TR 2SC2240 GR,BL (AM-A302, 402)
			83	ET-360067	TR 2SC3330 T,U F05 (AM-A302, 402)
			84	ET-310148	TR 2SD612K E,F (AM-A102, 202)
			85	N EV-363157	R S-FIX H RH0615CN4J 3P 333 (AM-A302, 402)
			86	N EV-364175	VR SLIDE 25P1SV W105
			87	N EV-364174	VR SLIDE 25P2SVOA W104
			88	EV-358563	VR SLIDE 60P2SVOM B254

**NOTE:**  
 N: New Parts

## 1. PC BOARD BLOCK (AM-A102)

REF. NO.	PART NO.	DESCRIPTION
1-1A	BA-A2047A030E	PC MAIN BLK AM-A102 [U]
1-1B	BA-A2047A030F	PC MAIN BLK AM-A102 [E,S,B]
1-2A	BA-A2047A020E	PC CONTROL BLK AM-A102 [U]
1-2B	BA-A2047A020C	PC CONTROL BLK AM-A202 [E,S,B]

## 1. PC BOARD BLOCK (AM-A202)

REF. NO.	PART NO.	DESCRIPTION
1-1A	BA-A2047A030A	PC MAIN BLK AM-A202 [U]
1-1B	BA-A2047A030B	PC MAIN BLK AM-A202 [C,A]
1-1C	BA-A2047A030C	PC MAIN BLK AM-A202 [E,B,S]
1-1D	BA-A2047A030D	PC MAIN BLK AM-A202 [V]
1-2A	BA-A2047A020A	PC CONTROL BLK AM-A202 [U]
1-2B	BA-A2047A020B	PC CONTROL BLK AM-A202 [C,A]
1-2C	BA-A2047A020C	PC CONTROL BLK AM-A202 [E,S,B]
1-2D	BA-A2047A020D	PC CONTROL BLK AM-A202 [V]

## 1. PC BOARD BLOCK (AM-A302)

REF. NO.	PART NO.	DESCRIPTION
1-1A	BA-A2048A020A	PC MAIN BLK AM-A302 [U]
1-1B	BA-A2048A020B	PC MAIN BLK AM-A302 [C,A]
1-1C	BA-A2048A020C	PC MAIN BLK AM-A302 [E,B,S]
1-1D	BA-A2048A020D	PC MAIN BLK AM-A302 [V]
1-2A	BA-A2048A030A	PC CONTROL BLK AM-A302 [U]
1-2B	BA-A2048A030B	PC CONTROL BLK AM-A302 [C,A]
1-2C	BA-A2048A030C	PC CONTROL BLK AM-A302 [E,B,S]
1-2D	BA-A2048A030D	PC CONTROL BLK AM-A302 [V]

## 1. PC BOARD BLOCK (AM-A402)

REF. NO.	PART NO.	DESCRIPTION
1-1A	BA-A2048A020E	PC MAIN BLK AM-A402 [U]
1-1B	BA-A2048A020F	PC MAIN BLK AM-A402 [C,A]
1-1C	BA-A2048A020G	PC MAIN BLK AM-A402 [E,S]
1-2A	BA-A2048A030E	PC CONTROL BLK AM-A402 [U]
1-2B	BA-A2048A030F	PC CONTROL BLK AM-A402 [C,A]
1-2C	BA-A2048A030G	PC CONTROL BLK AM-A402 [E,S]

### NOTE:

(1) PC MAIN BLK consists of following PC BOARDS.

- MAIN PC BOARDS
- SPEAKERS PC BOARD
- HEADPHONE PC BOARD
- FILTER PC BOARD (AM-A202 [V], AM-A302 [V] ONLY)

(2) PC CONTROL BLK consists of following PC BOARDS.

- CONTROL PC BOARD
- FUNCTION PC BOARD
- EQUALIZER PC BOARD
- PIN J PC BOARD
- POWER SW PC BOARD

## 2. MAIN PC BOARD (AM-A102, 202)

REF. NO.	PART NO.	DESCRIPTION
2-C13	EC-352643	C EC V 472M 40DC (AM-A102)
2-C13A	EC-358538	C EC V CUT 472M 45.0DC (AM-A202 [U,E,V,B,S])
2-C13B	EC-361665	C EC V CUT 472M 50.0DC (AM-A202 [C,A])
2-C16	EC-352643	C EC V 472M 40DC
2-C16A	EC-358538	C EC V CUT 472M 45.0DC [U,E,V,B,S]
2-C16B	EC-361665	C EC V CUT 472M 50.0DC [C,A]
2-C19	EC-326583	C MMY V CUT CF921 473K 400DC
2-D1	ED-301911	△ D SILICON H DS448
2-D2	ED-329056	△ D ZENER H HZ22 2
2-D3	ED-306320	△ D ZENER H HZ15 2
2-D4	ED-306320	△ D ZENER H HZ15 2
2-D5	ED-200213	△ D SILICON DBA40C-K15 200/2.6A (AM-A102)
2-D5	ED-350748	△ D SILICON DBA60C-K15 (AM-A202)
2-D6	ED-306320	D ZENER H HZ15 2
2-FR1	ER-328278	△ R FUSE ERD2FC 1/4W 10R0G
2-FR2	ER-200746	△ R FUSE ERD2FC 1/4W 1000G
2-FR3	ER-328278	△ R FUSE ERD2FC 1/4W 10R0G
2-FR4	ER-328278	△ R FUSE ERD2FC 1/4W 10R0G
2-L1	EO-337880	COIL FIX 2 202AK-018 2R2K
2-R7	ER-325269	△ R CB H S10 FS RDS 1/4W 222J
2-R9	ER-333355	△ R CB H S10 FS RDS 1/4W 103J
2-R10, 11	ER-308875	△ R CB H S15 FS RDS 1/2W 100J (AM-A102)
2-R10, 11	ER-341940	△ R OMF H S15 FS 1W 100J (AM-A202)
2-R12	ER-341331	△ R OMF H S15 FS 1W 181J (AM-A102)
2-R12	ER-305722	△ R OMF H S20 FS 2W 221J (AM-A202)
2-R15	ER-328082	△ R CB H S10 FS RDS 1/4W 332J
2-R17, 21	ER-328082	△ R CB H S10 FS RDS 1/4W 332J [U,E,V,B,S]
2-R18, 22	ER-323074	△ R CB H S10 FS RDS 1/4W 102J [U,E,V,B,S]
2-R19	ER-318430	△ R OMF H S15 FS 1W 102J
2-SW2	ES-359963	SW PUSH ESB-621566 2 THROW
2-TR1	ET-310148	△ TR 2SD612K E,F
2-TR2	ET-322598	△ TR 2SB632K E,F
2-TR3	ET-363953	△ TR DTA114TS
2-F3A, 4A	EF-326639	△ FUSE TSC A 250V 3.15A (AM-A102 [U])
2-F3B, 4B	EF-623125	△ FUSE SEMKO T 2.50A 250V (AM-A102 [E,S])
2-F3C, 4C	EF-364518	△ FUSE BET T 2.50A 250V (AM-A102 [B])
2-F3A, 4A	EF-306952	△ FUSE TSC A 250V 4.00A (AM-A202 [U])
2-F3B, 4B	EF-306957	△ FUSE TSC 125V 4.00A (AM-A202 [C,A])
2-F3C, 4C	EF-691007	△ FUSE SEMKO T 3.15A 250V (AM-A202 [E,V,S])
2-F3D, 4D	EF-359225	△ FUSE BET T 3.15A 250V (AM-A202 [B])

For Service Manuals Contact  
**MAURITRON TECHNICAL SERVICES**  
 8 Cherry Tree Rd, Chinnor  
 Oxon OX9 4QY  
 Tel: 01844-351694 Fax: 01844-352554  
 Email: enquires@mauritron.co.uk

## 2. MAIN PC BOARD (AM-A302, 402)

REF. NO.	PART NO.	DESCRIPTION
2-C10, 11	EC-201627	C EC V F05 SM 100M 100DC (AM-A402)
2-C13, 14	EC-325320	C EC V F05 NP AWA 2R2M 50DC
2-C18	EC-334005	C EC V CUT NP SM 331M 10DC (AM-A402)
2-C18	EC-334005	C EC V CUT NP SM 331M 10DC
2-C22	EC-326583	△ C MMY V CUT CF921 473K 400DC
2-C23, 26	EC-358559	C EC V CUT SM 682M 55.0DC (AM-A302 [U,E,V,B,S])
2-C23A, 26A	EC-360273	C EC V CUT SM 682M 71.0DC (AM-A302 [C,A], AM-A402)
2-D1 to 4	ED-348990	D SILICON H DS446
2-D5	ED-346627	△ D ZENER H HZ33 2
2-D6	ED-200749	△ D SILICON DBA60-K15 400/6.0A
2-D7, 8	ED-322046	△ D ZENER H HZ18 1
2-D9	ED-301911	D SILICON H DS448
2-FR1, 2	ER-200746	△ R FUSE ERD2FC 1/4W 1000G
2-FR3 to 5	ER-345751	△ R FUSE ERD2FC S10 1/4W 15R0G
2-IC2	EI-349719	IC M5218P
2-IC3	EI-354080	IC µPC1237H
2-L1	EO-332116	COIL FIX 2 103AK-006A 2R2K
2-RL1	EQ-337159	△ RELAY POWER G4Z-2282P 2N0 24V
2-R11	ER-345466	△ R CT P F09 PLATE 5W R22K
2-R12	ER-341940	△ R OMF H S15 FS 1W 100J (AM-A302)
2-R12	ER-333023	△ R OMF H S20 FS 2W 100J (AM-A402)
2-R13	ER-341940	△ R OMF H S15 FS 1W 100J (AM-A302)
2-R13	ER-333023	△ R OMF H S20 FS 2W 100J (AM-A402)
2-R25	ER-333663	△ R CB H S15 FS RDS 1/2W 391J
2-R26	ER-306128	△ R CB H S15 FS RDS 1/2W 103J
2-R27	ER-333102	△ R OMF H S20 FS 2W 431J
2-SW1	ES-358556	SW PUSH ESB-621519 2 THROW
2-TR1	ET-307195	TR 2SC2240 GR,BL
2-TR2	ET-305463	TR 2SA970 GR,BL
2-TR3, 4	ET-344176	△ TR 2SD313HP F
2-TR5	ET-347026	△ TR 2SB507HP E,F
2-TR6	ET-360067	TR 2SC3330 T,U F05
2-F3A, 4A	EF-341260	△ FUSE TSC A 250V 8.00A [U]
2-F3B, 4B	EF-345658	△ FUSE TSC 125V 8.00A [C,A]
2-F3C, F4C	EF-249851	△ FUSE SEMKO T 5.00A 250V (AM-A302 [E,V,S])
2-F3C, 4C	EF-242605	△ FUSE SEMKO T 6.30A 250V (AM-A402 [E,S])
2-F3D, 4D	EF-355399	△ FUSE BET T 5.00A 250V (AM-A302 [B])

## 3. CONTROL PC BOARD (AM-A102, 202)

REF. NO.	PART NO.	DESCRIPTION
3-D1	ED-354114	D LED BR-5507S RED
3-D2	ED-361803	D LED SLP484C-51 YELLOW
3-D3 to 5	ED-361885	D LED SLP284C-51U GREEN
3-IC1	EI-355211	IC M5227P
3-R8, 9	ER-333598	R CB H S15 FS RDS 1/2W 102J
3-R10, 11	ER-306805	R CB H S15 FS RDS 1/2W 101J
3-SW1	ES-364176	SW PUSH SPPH11 2-02-02N
3-VR1 to 5	EV-364174	VR SLIDE 25P2SVOA W104
3-VR6	EV-364175	VR SLIDE 25P1SV W105
3-VR7	EV-358563	VR SLIDE 60P2SVOM B254

## 3. CONTROL PC BOARD (AM-A302, 402)

REF. NO.	PART NO.	DESCRIPTION
3-D1 to 3	ED-361885	D LED SLP284C-51U GREEN
3-D4, 5, 12	ED-354114	D LED BR-5507S RED
3-D6 to 9	ED-361885	D LED SLP284C-51U GREEN
3-D10, 11	ED-361803	D LED SLP484C-51 YELLOW
3-D13	ED-313846	D ZENER H HZ16 3
3-IC1	EI-355211	IC M5227P
3-IC2	EI-358562	IC LB1416
3-R15, 16	ER-333692	△ R CB H S15 FS RDS 1/2W 750J
3-R23	ER-333639	△ R CB H S15 FS RDS 1/2W 242J
3-R24 to 27	ER-333680	△ R CB H S15 FS RDS 1/2W 560J
3-SW1	ES-364176	SW PUSH SPPH11 2-02-02N
3-TR1	ET-360067	TR 2SC3330 T,U F05
3-TR2	ET-353899	TR 2SA1317 S,T,U
3-VR1 to 5	EV-364174	VR SLIDE 25P2SVOA W104
3-VR6	EV-364175	VR SLIDE 25P1SV W105
3-VR7	EV-358563	VR SLIDE 60P2SVOM B254
3-VR8	EV-363157	R S-FIX H RH0615CN4J 3P 333

## 4. FUNCTION PC BOARD (AM-A102, 202)

REF. NO.	PART NO.	DESCRIPTION
4-IC1	EI-349719	IC M5218P
4-R5, 6	ER-333616	R CB H S15 FS RDS 1/2W 151J
4-SW1	ES-358537	SW PUSH ESB-62968 4 THROW

## 4. FUNCTION PC BOARD (AM-A302, 402)

REF. NO.	PART NO.	DESCRIPTION
4-IC1	EI-337228	IC M5218L
4-R5, 6	ER-324935	R CB H S15 FS RDS 1/2W 181J
4-R7 to 12	ER-318430	R OMF H S15 FS 1W 102J (AM-A302)
4-R7 to 12	ER-324670	R OMF H S20 FS 2W 102J (AM-A402)
4-SW1	ES-358564	SW PUSH ESB-62969 6 THROW

## 5. EQUALIZER PC BOARD

REF. NO.	PART NO.	DESCRIPTION
5-IC1	EI-344764	IC M5218P-21
5-P1	EJ-336904	PIN J AJC-036-ACB P 6P
5-R9, 10	ER-333616	R CB H S15 FS RDS 1/2W 151J (AM-A102, 202)
5-R9, 10	ER-324935	R CB H S15 FS RDS 1/2W 181J (AM-A302, 402)

## 6. PIN J PC BOARD

REF. NO.	PART NO.	DESCRIPTION
6-P1, 2	EJ-343365	PIN J YMC21-0063 P 4P
6-P3	EJ-364546	PIN J YKC21-0070A P 2P (AM-A102, 202)
6-P3, 4	EJ-343365	PIN J YMC21-0063 P 4P (AM-A302, 402)

## 7. SPEAKERS PC BOARD

REF. NO.	PART NO.	DESCRIPTION
7-TM902	EJ-349401	TERMINAL LEVER YKD21-0027

8P

## 8. HEAD PHONE PC BOARD

REF. NO.	PART NO.	DESCRIPTION
8-J1	EJ-358535	PHONE J 3P M1669-ACCB 6.3
8-L1	EO-336934	COIL FIX 1 LAL03KH 2R2M (AM-A202 [V], AM-A302 [V])

## 9. POWER SW PC BOARD

REF. NO.	PART NO.	DESCRIPTION
9-C1A	EC-320548	△ C CE V F 103Z 250AC [U]
9-C1B	EC-338411	△ C CE V FZ 103P 400AC [C,A]
9-C1C	EC-338496	△ C CE V FZ 472P 400AC [E,V,B,S]
9-SW1	ES-337902	△ SW PUSH SDDL1P 01-1 (AM-A102, AM-A202)
9-SW1	ES-361970	△ SW PUSH SDDL1 01-1 (AM-A302, AM-A402)
9-F1A	EF-311839	△ FUSE TSC A 250V 1.60A (AM-A102 [U])
9-F1A	EF-326639	△ FUSE TSC A 250V 3.15A (AM-A202 [U])
9-F1A	EF-326639	△ FUSE TSC A 250V 3.15A (AM-A302 [U])
9-F1A	EF-306952	△ FUSE TSC A 250V 4.00A (AM-A402 [U])
9-F1B	EF-323080	△ FUSE TSC 125V 3.15A (AM-A202 [C,A])
9-F1B	EF-346139	△ FUSE TSC 125V 5.00A (AM-A302 [C,A])
9-F1B	EF-346115	△ FUSE TSC 125V 6.30A (AM-A402 [C,A])
9-F1C	EF-602550	△ FUSE SEMKO T 1.25A 250V (AM-A102 [E,S], 202 [E,V,S])
9-F1C	EF-601301	△ FUSE SEMKO T 2.00A 250V (AM-A302 [E,V,S])
9-F1C	EF-691007	△ FUSE SEMKO T 3.15A 250V (AM-A402 [E,S])
9-F1D	EF-359007	△ FUSE BET T 1.25A 250V (AM-A102 [B], 202 [B])
9-F1D	EF-355398	△ FUSE BET T 2.00A 250V (AM-A302 [B])
9-F2	EF-311839	△ FUSE TSC A 250V 1.60A (AM-A102 [U])
9-F2	EF-326639	△ FUSE TSC A 250V 3.15A (AM-A202 [U], 302 [U])
9-F2	EF-306952	△ FUSE TSC A 250V 4.00A (AM-A402 [U])

## 10. FILTER PC BOARD (AM-A202, 302 [V] ONLY)

REF. NO.	PART NO.	DESCRIPTION
10-L1	EO-338409	COIL LF FKOB160MH02 250UH (V)

For Service Manuals Contact  
MAURITRON TECHNICAL SERVICES  
8 Cherry Tree Rd, Chinnor  
Oxon OX9 4QY  
Tel: 01844-351694 Fax: 01844-352554  
Email: enquiries@mauritron.co.uk

## ASSEMBLY BLOCK

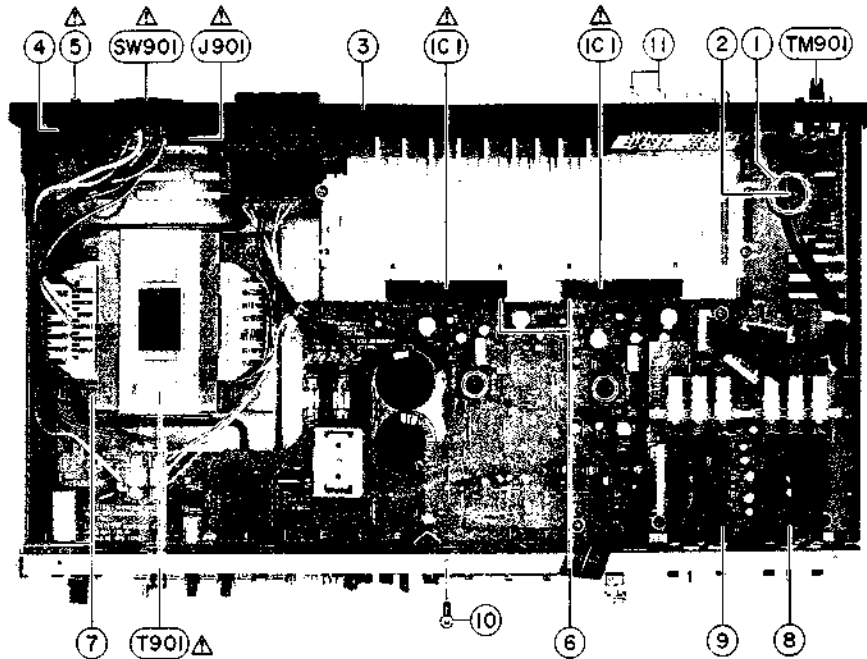

For Service Manuals Contact  
**MAURITRON TECHNICAL SERVICES**  
 8 Cherry Tree Rd, Chinnor  
 Oxon OX9 4QY  
 Tel: 01844-351694 Fax: 01844-352554  
 Email: enquiries@mauritron.co.uk

### 11. ASSEMBLY BLOCK

REF. NO.	PART NO.	DESCRIPTION	REF. NO.	PART NO.	DESCRIPTION
11-1	SA-332850	ROUND FOOT	11-T901A	BT-364647	△ TRANS POWER AM-A402T-70 (U) (AM-A402 [U])
11-2	ZS-311745	T2BR30x08STL BNI PW080 (FOOT FIX)	11-T901B	BT-364154	△ TRANS POWER AM-A202-30 (AM-A202 [C])
11-3A	SP-364012A	PANEL REAR AM-A102 [U]	11-T901B	BT-364552	△ TRANS POWER AM-A202-30 (C,A) (AM-A302 [C,A])
11-3A	SP-364012D	PANEL REAR AM-A202 [U]	11-T901B	BT-364649	△ TRANS POWER AM-A402T-20 (C,A) (AM-A402 [C,A])
11-3A	SP-364012H	PANEL REAR AM-A302 [U]	11-T901C	BT-364155	△ TRANS POWER AM-A202-20 (AM-A202 [A])
11-3A	SP-364012M	PANEL REAR AM-A402 [U]	11-T901B	BT-352430	△ TRANS POWER AM-A1T-40 (AM-A102 [E])
11-3B	SP-364012E	PANEL REAR AM-A202 [C,A]	11-T901D	BT-358520	△ TRANS POWER AM-A201-40 (E) (AM-A202 [E])
11-3B	SP-364012J	PANEL REAR AM-A302 [C,A]	11-T901C	BT-358549	△ TRANS POWER AM-A301-40 (E,V) (AM-A302 [E,V])
11-3B	SP-364012N	PANEL REAR AM-A402 [C,A]	11-T901C	BT-364650	△ TRANS POWER AM-A402T-40 (E) (AM-A402 [E])
11-3B	SP-364012P	PANEL REAR AM-A102 [E]	11-T901C	BT-352431	△ TRANS POWER AM-A1T-50 (AM-A102 [B,S])
11-3C	SP-364012F	PANEL REAR AM-A202 [E,V]	11-T901E	BT-358521	△ TRANS POWER AM-A201-50 (B,S) (AM-A202 [B,S])
11-3C	SP-364012K	PANEL REAR AM-A302 [E,V]	11-T901D	BT-358550	△ TRANS POWER AM-A301-50 (B,S) (AM-A302 [B,S])
11-3C	SP-364012P	PANEL REAR AM-A402 [E]	11-T901D	BT-364651	△ TRANS POWER AM-A402T-50 (S) (AM-A402 [S])
11-3C	SP-364012C	PANEL REAR AM-A102 [S,B]	11-T901F	BT-370321	△ TRANS POWER A2047-V (AM-A202 [V])
11-3D	SP-364012G	PANEL REAR AM-A202 [B,S]	11-J901A	EJ-337405	△ SOCKET OUTLET S2T733T114T [C,A] JUC 3x2P [U]
11-3D	SP-364012L	PANEL REAR AM-A302 [B,S]	11-J901B	EJ-352642	△ SOCKET OUTLET S2T733T114T [C,A]
11-3D	SP-364012Q	PANEL REAR AM-A402 [S]	11-SW901	ES-349070	△ SW SELECTOR YKSI11-0002 02-4 [U]
11-4	ZS-308846	T2BR30x08STL BZN PROJECTION (PANEL REAR FIX)	11-TM901	EJ-329610	TERMINAL W/SCREW UB-0067 L 1P
11-5A	EW-354515	△ AC CORD 2 CORES KP-700A, VFF-CB U/T [U]	11-IC1	EI-352644	△ IC STK4141II (AM-A102)
11-5B	EW-358513	△ AC CORD 2 CORES KD-3W, SPT-2-CB UC [C,A]	11-IC1A	EI-358554	△ IC STK4152II (AM-A202 [U,E,V,B,S])
11-5C	EW-354625	△ AC CORD 2 CORES KP-419C, LTCE-2F E [E]	11-IC1A	EI-366366	△ IC STK4038II (AM-A302 [U,E,V,B,S])
11-5D	EW-354513	△ AC CORD 2 CORES KP-419C, LTCE-2F EV [V]	11-IC1	EI-364646	△ IC STK4044II (AM-A402)
11-5E	EW-354512	△ AC CORD 2 CORES LTBS-2F-CB B [B]	11-IC1B	EI-364171	△ IC STK4171II (AM-A202 [C,A])
11-5F	EW-354514	△ AC CORD 2 CORES KP-560, LTSA2F-CB S [S]	11-IC1B	EI-364549	△ IC STK4042II (AM-A302 [C,A])
11-6	ZS-321279	T2BR30x18STL CMT (IC FIX)			
11-7	ZS-346742	ST BID40x08STL CMT CUP (TRANS POWER FIX)			
11-8	TA-358475	JOINT (A)			
11-9	TA-358473B	JOINT (B)-2			
11-10	ZS-498273	T2BR30x08STL CMT PW080 (PANEL FRONT FIX)			
11-11	EJ-348218	PLUG SHORT PIN P2138			
11-T901A	BT-352426	△ TRANS POWER AM-A1T-70 (AM-A102 [U])			
11-T901A	BT-358517	△ TRANS POWER AM-A201-70 (U) (AM-A202 [U])			
11-T901A	BT-358545	△ TRANS POWER AM-A301-70 (U) (AM-A302 [U])			

## FINAL ASSEMBLY BLOCK

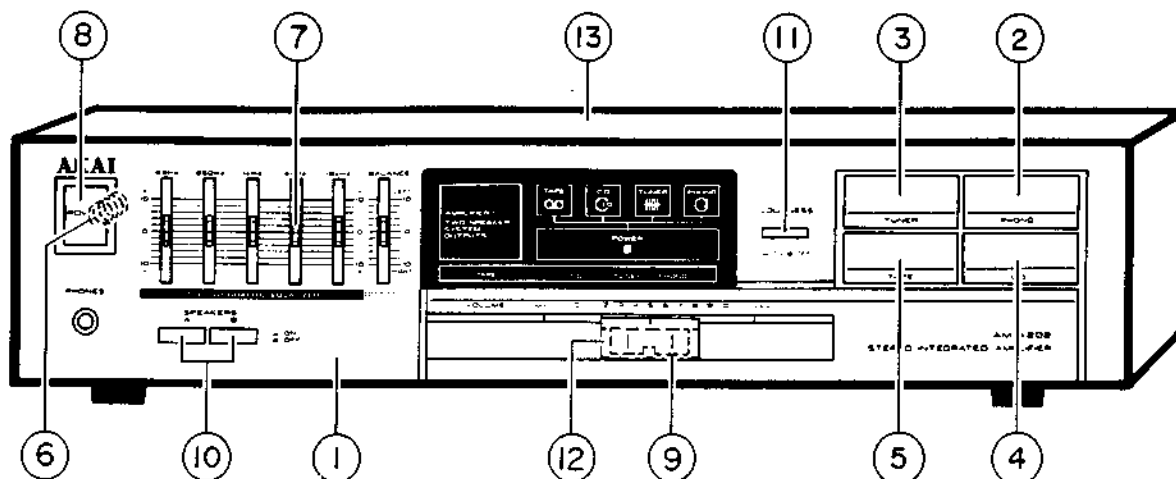

### 12. FINAL ASSEMBLY BLOCK (AM-A102, 202)

REF. NO.	PART NO.	DESCRIPTION	REF. NO.	PART NO.	DESCRIPTION
<b>PANEL FRONT BLOCK</b>			<b>FINAL ASSEMBLY BLOCK</b>		
12-1	BD-A2047A090C	PANEL FRONT BLK AM-A102	12-9	SZ-358557	SHEET
12-1	BD-A2047A090A	PANEL FRONT BLK AM-A202	12-10	SK-358479B	KNOB (F-2)
12-1-B	BD-A2047A090D	PANEL FRONT BLK AM-A102-B	12-10-B	SK-358479A	KNOB (F-1)
12-1-B	BD-A2047A090B	PANEL FRONT BLK AM-A202-B	12-11	SK-363998A	KNOB LOUDNESS
12-2	SK-363997A	KNOB FUNCTION (A) PHONO	12-11-B	SK-363998B	KNOB LOUDNESS-B
12-2-B	SK-363997E	KNOB FUNCTION (A) PHONO-B	12-12	SK-358474B	KNOB (D-2)
12-3	SK-363997B	KNOB FUNCTION (A) TUNER	12-12-B	SK-358474A	KNOB (D-1)
12-3-B	SK-363997F	KNOB FUNCTION (A) TUNER-B	12-13	SP-349925A	COVER UPPER
12-4	SK-363997C	KNOB FUNCTION (A) CD	12-13-B	SP-349925C	COVER UPPER-B
12-4-B	SK-363997G	KNOB FUNCTION (A) CD-B			
12-5	SK-363997D	KNOB FUNCTION (A) TAPE			
12-5-B	SK-363997H	KNOB FUNCTION (A) TAPE-B			
12-6	ZG-355238	SP PUSH POWER			
12-7	SK-363999	KNOB EQ			
12-7-B	SK-363999B	KNOB EQ-B			
12-8	SK-343017C	KNOB POWER (2)			
12-8-B	SK-343017F	KNOB POWER-B			

**NOTE:**

PANEL FRONT BLK includes 12-2 to 12-8.

SYMBOL FOR COLOR VARIATION

NON: STANDARD COLOR

-B : BLACK

For Service Manuals Contact  
**MAURITRON TECHNICAL SERVICES**  
 8 Cherry Tree Rd, Chinnor  
 Oxon OX9 4QY  
 Tel: 01844-351694 Fax: 01844-352554  
 Email: enquiries@mauritron.co.uk

## FINAL ASSEMBLY BLOCK

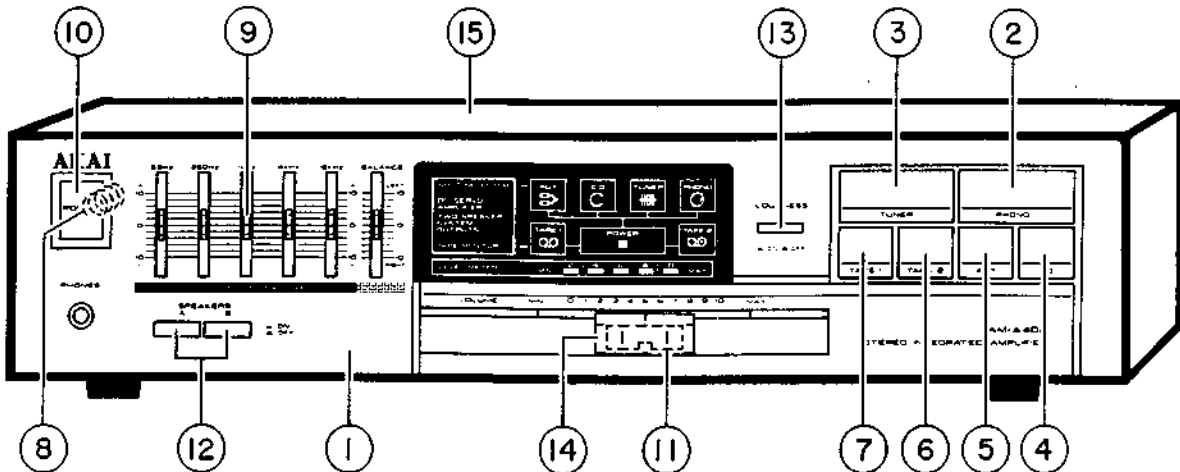

### 12. FINAL ASSEMBLY BLOCK (AM-A302, 402)

REF. NO. PART NO. DESCRIPTION

#### PANEL FRONT BLOCK

12-1	BD-A2048A040A	PANEL FRONT BLK AM-A302
12-1	BD-A2048A040C	PANEL FRONT BLK AM-A402
12-1-B	BD-A2048A040B	PANEL FRONT BLK AM-A302-B
12-1-B	BD-A2048A040D	PANEL FRONT BLK AM-A402-B
12-2	SK-363997A	KNOB FUNCTION (A) PHONO
12-2-B	SK-363997E	KNOB FUNCTION (A) PHONO-B
12-3	SK-363997B	KNOB FUNCTION (A) TUNER
12-3-B	SK-363997F	KNOB FUNCTION (A) TUNER-B
12-4	SK-364457A	KNOB FUNCTION (B) CD
12-4-B	SK-364457E	KNOB FUNCTION (B) CD-B
12-5	SK-364457B	KNOB FUNCTION (B) AUX
12-5-B	SK-364457F	KNOB FUNCTION (B) AUX-B
12-6	SK-364457C	KNOB FUNCTION (B) TAPE 2
12-6-B	SK-364457G	KNOB FUNCTION (B) TAPE 2-B
12-7	SK-364457D	KNOB FUNCTION (B) TAPE 1
12-7-B	SK-364457H	KNOB FUNCTION (B) TAPE 1-B
12-8	ZG-355238	SP PUSH POWER
12-9	SK-363999	KNOB EQ
12-9-B	SK-363999B	KNOB EQ-B
12-10	SK-343017C	KNOB POWER (2)
12-10-B	SK-343017F	KNOB POWER-B

REF. NO. PART NO. DESCRIPTION

#### FINAL ASSEMBLY BLOCK

12-11	SZ-358557	SHEET
12-12	SK-358479B	KNOB (F-2)
12-12-B	SK-358479A	KNOB (F-1)
12-13	SK-363998A	KNOB LOUDNESS
12-13-B	SK-363998B	KNOB LOUDNESS-B
12-14	SK-358474B	KNOB (D-2)
12-14-B	SK-358474A	KNOB (D-1)
12-15	SP-349925E	COVER UPPER (B) (AM-A302)
12-15	SP-349925G	COVER UPPER (C) (AM-A402)
12-15-B	SP-349925F	COVER UPPER (B)-B (AM-A302)
12-15-B	SP-349925H	COVER UPPER (C)-B (AM-A402)

#### NOTE:

PANEL FRONT BLK includes 12-2 to 12-10.

SYMBOL FOR COLOR VARIATION

NON: STANDARD COLOR

-B : BLACK

For Service Manuals Contact  
**MAURITRON TECHNICAL SERVICES**  
 8 Cherry Tree Rd, Chinnor  
 Oxon OX9 4QY  
 Tel: 01844-351694 Fax: 01844-352554  
 Email: enquiries@mauritron.co.uk



# INDEX

## AM-A102/A202

PART NO.	REF. NO.	PART NO.	REF. NO.	PART NO.	REF. NO.	PART NO.	REF. NO.
BA-A2047A020A	1-2A	EF-323080	9-F1B	ER-333616	5-R9	SP-364012D	11-3A
BA-A2047A020B	1-2B	EF-326639	9-F1A,2-F3A	ER-333616	5-R10	SP-364012E	11-3B
BA-A2047A020C	1-2C,1-2B	EF-326639	9-F2,2-F4A	ER-341331	2-R12	SP-364012F	11-3C
BA-A2047A020D	1-2D	EF-359007	9-F1D	ER-341940	2-R10	SP-364012G	11-3D
BA-A2047A020E	1-2A	EF-359225	2-F3D	ER-341940	2-R11	SZ-358557	12-9
BA-A2047A030A	1-1A	EF-359225	2-F4D	ES-337902	9-SW1	TA-358473B	11-9
BA-A2047A030B	1-1B	EF-364518	2-F3C,F4C	ES-349070	11-SW901	TA-358475	11-8
BA-A2047A030C	1-1C	EF-602550	9-F1C	ES-358537	4-SW1	ZG-355238	12-6
BA-A2047A030D	1-1D	EF-623125	2-F3B,F4B	ES-359963	2-SW2	ZS-308846	11-4
BA-A2047A030E	1-1A	EF-691007	2-F3C	ES-364176	3-SW1	ZS-311745	11-2
BA-A2047A030F	1-1B	EF-691007	2-F4C	ET-310148	2-TR1	ZS-321279	11-6
BD-A2047A090A	12-1	EI-344764	5-IC1	ET-322598	2-TR2	ZS-346742	11-7
BD-A2047A090B	12-1-B	EI-349719	4-IC1	ET-363953	2-TR3	ZS-498273	11-10
BD-A2047A090C	12-1	EI-352644	11-IC1	EV-358563	3-VR7		
BD-A2047A090D	12-1-B	EI-355211	3-IC1	EV-364174	3-VR1		
BT-352426	11-T901A	EI-358554	11-IC1A	EV-364174	3-VR2		
BT-352430	11-T901B	EI-364171	11-IC1B	EV-364174	3-VR3		
BT-352431	11-T901C	EJ-329610	11-TM901	EV-364174	3-VR4		
BT-358517	11-T901A	EJ-336904	5-P1	EV-364174	3-VR5		
BT-358520	11-T901D	EJ-337405	11-J901A	EV-364175	3-VR6		
BT-358521	11-T901E	EJ-343365	6-P1	EW-354512	11-5E		
BT-364154	11-T901B	EJ-343365	6-P2	EW-354513	11-5D		
BT-364155	11-T901C	EJ-348218	11-11	EW-354514	11-5F		
BT-370321	11-T901F	EJ-349401	7-TM902	EW-354515	11-5A		
EC-320548	9-C1A	EJ-352642	11-J901B	EW-354625	11-5C		
EC-326583	2-C19	EJ-358535	8-J1	EW-358513	11-5B		
EC-338411	9-C1B	EJ-364546	6-P3	SA-332850	11-1		
EC-338496	9-C1C,9-C1B	EO-336934	8-L1	SK-343017C	12-8		
EC-352643	2-C13,C16	EO-337880	2-L1	SK-343017F	12-8-B		
EC-358538	2-C16A	EO-338409	10-L1	SK-358474A	12-12-B		
EC-358538	2-C13A	ER-200746	2-FR2	SK-358474B	12-12		
EC-361665	2-C13B	ER-305722	2-R12	SK-358479A	12-10-B		
EC-361665	2-C16B	ER-306805	3-R10	SK-358479B	12-10		
ED-200213	2-D5	ER-306805	3-R11	SK-363997A	12-2		
ED-301911	2-D1	ER-308875	2-R10,R11	SK-363997B	12-3		
ED-306320	2-D3	ER-318430	2-R19	SK-363997C	12-4		
ED-306320	2-D4	ER-323074	2-R18	SK-363997D	12-5		
ED-306320	2-D6	ER-323074	2-R22	SK-363997E	12-2-B		
ED-329056	2-D2	ER-325269	2-R7	SK-363997F	12-3-B		
ED-350748	2-D5	ER-328082	2-R15	SK-363997G	12-4-B		
ED-354114	3-D1	ER-328082	2-R17	SK-363997H	12-5-B		
ED-361803	3-D2	ER-328082	2-R21	SK-363998A	12-11		
ED-361885	3-D3	ER-328278	2-FR1	SK-363998B	12-11-B		
ED-361885	3-D4	ER-328278	2-FR3	SK-363999	12-7		
ED-361885	3-D5	ER-328278	2-FR4	SK-363999B	12-7-B		
EF-306952	2-F3A	ER-333355	2-R9	SP-349925A	12-13		
EF-306952	2-F4A	ER-333598	3-R8	SP-349925C	12-13-B		
EF-306957	2-F3B	ER-333598	3-R9	SP-364012A	11-3A		
EF-306957	2-F4B	ER-333616	4-R5	SP-364012B	11-3B		
EF-311839	9-F1A,F2	ER-333616	4-R6	SP-364012C	11-3C		

For Service Manuals Contact  
**MAURITRON TECHNICAL SERVICES**  
 8 Cherry Tree Rd, Chinnor  
 Oxon OX9 4QY  
 Tel: 01844-351894 Fax: 01844-352554  
 Email: enquiries@mauritron.co.uk

**AM-A302/A402**

PART NO.	REF. NO.	PART NO.	REF. NO.	PART NO.	REF. NO.	PART NO.	REF. NO.
BA-A2048A020A	1-1A	EF-242605	2-F3C,F4C	ER-333680	3-R25	SK-364457H	12-7-B
BA-A2048A020B	1-1B	EF-249851	2-F3C	ER-333680	3-R26	SP-349925E	12-15
BA-A2048A020C	1-1C	EF-249851	2-F4C	ER-333680	3-R27	SP-349925F	12-15-B
BA-A2048A020D	1-1D	EF-306952	9-F1A,F2	ER-333692	3-R15	SP-349925G	12-15
BA-A2048A020E	1-1A	EF-326639	9-F1A	ER-333692	3-R16	SP-349925H	12-15-B
BA-A2048A020F	1-1B	EF-326639	9-F2	ER-341940	2-R12	SP-364012H	11-3A
BA-A2048A020G	1-1C	EF-341260	2-F3A	ER-341940	2-R13	SP-364012J	11-3B
BA-A2048A030A	1-2A	EF-341260	2-F4A	ER-345466	2-R11	SP-364012K	11-3C
BA-A2048A030B	1-2B	EF-345658	2-F3B	ER-345751	2-FR3	SP-364012L	11-3D
BA-A2048A030C	1-2C	EF-345658	2-F4B	ER-345751	2-FR4	SP-364012M	11-3A
BA-A2048A030D	1-2D	EF-346115	9-F1B	ER-345751	2-FR5	SP-364012N	11-3B
BA-A2048A030E	1-2A	EF-346139	9-F1B	ES-349070	11-SW901	SP-364012P	11-3C
BA-A2048A030F	1-2B	EF-355398	9-F1D	ES-358556	2-SW1	SP-364012Q	11-3D
BA-A2048A030G	1-2C	EF-355399	2-F3D	ES-358564	4-SW1	SZ-358557	12-11
BD-A2048A040A	12-1	EF-355399	2-F4D	ES-361970	9-SW1	TA-358473B	11-9
BD-A2048A040B	12-1-B	EF-601301	9-F1C	ES-364176	3-SW1	TA-358475	11-8
BA-A2048A040C	12-1	EF-691007	9-F1C	ET-305463	2-TR2	ZG-355238	12-8
BA-A2048A040D	12-1-B	EL-337228	4-IC1	ET-307195	2-TR1	ZS-308846	11-4
BT-358545	11-T901A	EL-344764	5-IC1	ET-344176	2-TR3	ZS-311745	11-2
BT-358549	11-T901C	EL-349719	2-IC2	ET-344176	2-TR4	ZS-321279	11-6
BT-358550	11-T901D	EL-354080	2-IC3	ET-347026	2-TR5	ZS-346742	11-7
BT-364552	11-T901B	EL-355211	3-IC1	ET-353899	3-TR2	ZS-498273	11-10
BT-364647	11-T901A	EL-358562	3-IC2	ET-360067	2-TR6		
BT-364649	11-T901B	EL-364549	11-IC1B	ET-360067	3-TR1		
BT-364650	11-T901C	EL-364646	11-IC1	EV-358563	3-VR7		
BT-364651	11-T901D	EL-366366	11-IC1A	EV-363157	3-VR8		
EC-201627	2-C10,C11	EJ-329610	11-TM901	EV-364174	3-VR1		
EC-320548	9-C1A	EJ-336904	5-P1	EV-364174	3-VR2		
EC-325320	2-C13	EJ-337405	11-J901A	EV-364174	3-VR3		
EC-325320	2-C14	EJ-343365	6-P1	EV-364174	3-VR4		
EC-326583	2-C22	EJ-343365	6-P2	EV-364174	3-VR5		
EC-334005	2-C18	EJ-343365	6-P3	EV-364175	3-VR6		
EC-338411	9-C1B	EJ-343365	6-P4	EW-354512	11-5E		
EC-338496	9-C1C	EJ-348218	11-11	EW-354513	11-5D		
EC-358559	2-C23	EJ-349401	7-TM902	EW-354514	11-5F,11-5D		
EC-358559	2-C26	EJ-352642	11-J901B	EW-354515	11-5A		
EC-360273	2-C23A	EJ-358535	8-J1	EW-354625	11-5C		
EC-360273	2-C26A	EO-332116	2-L1	EW-358513	11-5B		
ED-200749	2-D6	EO-336934	8-L1	SA-332850	11-1		
ED-301911	2-D9	EO-338409	10-L1	SK-343017C	12-10		
ED-313846	3-D13	EQ-337159	2-RL1	SK-343017F	12-10-B		
ED-322046	2-D7	ER-200746	2-FR1	SK-358474A	12-14-B		
ED-322046	2-D8	ER-200746	2-FR2	SK-358474B	12-14		
ED-346627	2-D5	ER-306128	2-R26	SK-358479A	12-12-B		
ED-348990	2-D1	ER-318430	4-R7	SK-358479B	12-12		
ED-348990	2-D2	ER-318430	4-R8	SK-363997A	12-2		
ED-348990	2-D3	ER-318430	4-R9	SK-363997B	12-3		
ED-348990	2-D4	ER-318430	4-R10	SK-363997E	12-2-B		
ED-354114	3-D4	ER-318430	4-R11	SK-363997F	12-3-B		
ED-354114	3-D5	ER-318430	4-R12	SK-363998A	12-13		
ED-354114	3-D12	ER-324670	4-R7 to R12	SK-363998B	12-13-B		
ED-361803	3-D10	ER-324935	4-R5	SK-363999	12-9		
ED-361803	3-D11	ER-324935	4-R6	SK-363999B	12-9-B		
ED-361885	3-D1	ER-324935	5-R9	SK-364457A	12-4		
ED-361885	3-D2	ER-324935	5-R10	SK-364457B	12-5		
ED-361885	3-D3	ER-333023	2-R13	SK-364457C	12-6		
ED-361885	3-D6	ER-333102	2-R27	SK-364457D	12-7		
ED-361885	3-D7	ER-333639	3-R23	SK-364457E	12-4-B		
ED-361885	3-D8	ER-333663	2-R25	SK-364457F	12-5-B		
ED-361885	3-D9	ER-333680	3-R24	SK-364457G	12-6-B		

For Service Manuals Contact  
**MAURITRON TECHNICAL SERVICES**  
 8 Cherry Tree Rd, Chinnor  
 Oxon OX9 4QY  
 Tel: 01844-351694 Fax: 01844-352554  
 Email: enquiries@mauritron.co.uk

## ABBREVIATIONS (AMPLIFIER)

ABBREVIATIONS	EXPLANATION
AC	Alternating Current
AMP	AMPlifier
CD	Compact Disc
DC	Direct Current
GND	GrouND
MC	Moving Coil
MM	Moving Magnet
PCB	Printed Circuit Board
REC	RECORD
SW	SWitch
V.DISC	Video DISC
VR	Variable Resistance
VTR	Video Tape Recorder

For Service Manuals Contact  
MAURITRON TECHNICAL SERVICES  
8 Cherry Tree Rd, Chinnor  
Oxon OX9 4QY  
Tel:- 01844-351694 Fax:- 01844-352554  
Email:- enquiries@mauritron.co.uk

# AKAI

MODEL **AM-A102**

MODEL **AM-A202**

MODEL **AM-A302**

MODEL **AM-A402**

## **SCHEMATIC DIAGRAM AND PCB BOARDS**

For Service Manuals Contact  
**MAURITRON TECHNICAL SERVICES**  
8 Cherry Tree Rd, Chinnor  
Oxon OX9 4QY  
Tel: 01844-351694 Fax: 01844-352554  
Email: enquiries@mauritron.co.uk

### TABLE OF CONTENTS

1. BLOCK DIAGRAM AM-A102/202 .....	2
2. BLOCK DIAGRAM AM-A302/402 .....	3
3. PIN JACK PCB, FUNCTION PCB EQUALIZER PCB.....	4
4. POWER SW PCB, FILTER PCB, CONTROL PCB.....	5
5. MAIN PCB AM-A102/202 .....	6
6. SCHEMATIC DIAGRAM AM-A102/202 .....	7
7. SCHEMATIC DIAGRAM AM-A302/402 .....	8
8. MAIN PCB AM-A302/402 .....	9
9. POWER SW PCB, FILTER PCB, CONTROL PCB.....	10
10. PIN JACK PCB, FUNCTION PCB EQUALIZER PCB.....	11
11. ICs .....	12

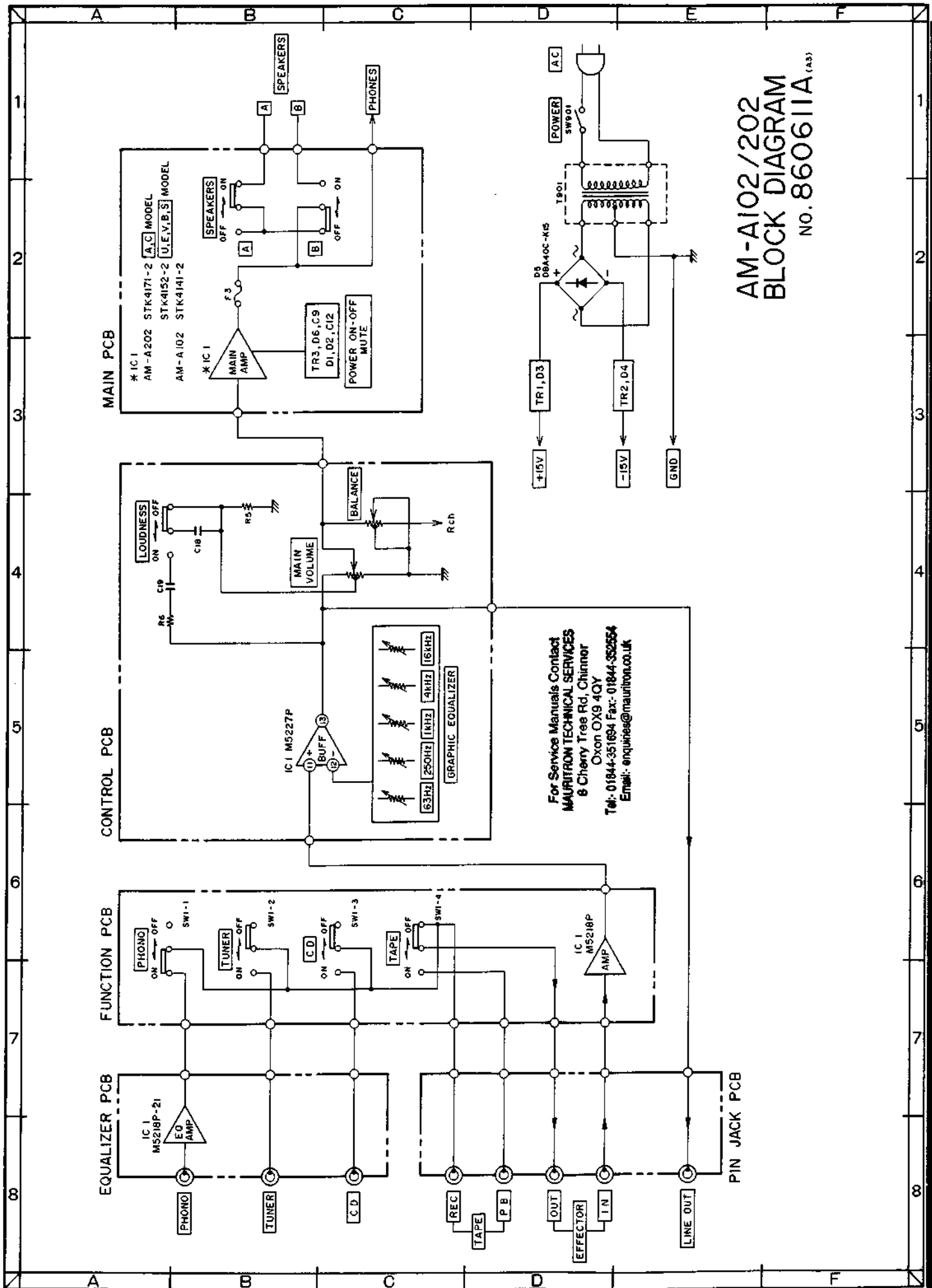

**AM-A102/202**  
**BLOCK DIAGRAM**  
 NO. 860611A (A3)

For Service Manuals Contact  
**MAURITRON TECHNICAL SERVICES**  
 8 Cherry Tree Rd, Chinner  
 Oxon OX9 4QY  
 Tel: 01844-351694 Fax: 01844-352554  
 Email: enquiries@mauritron.co.uk

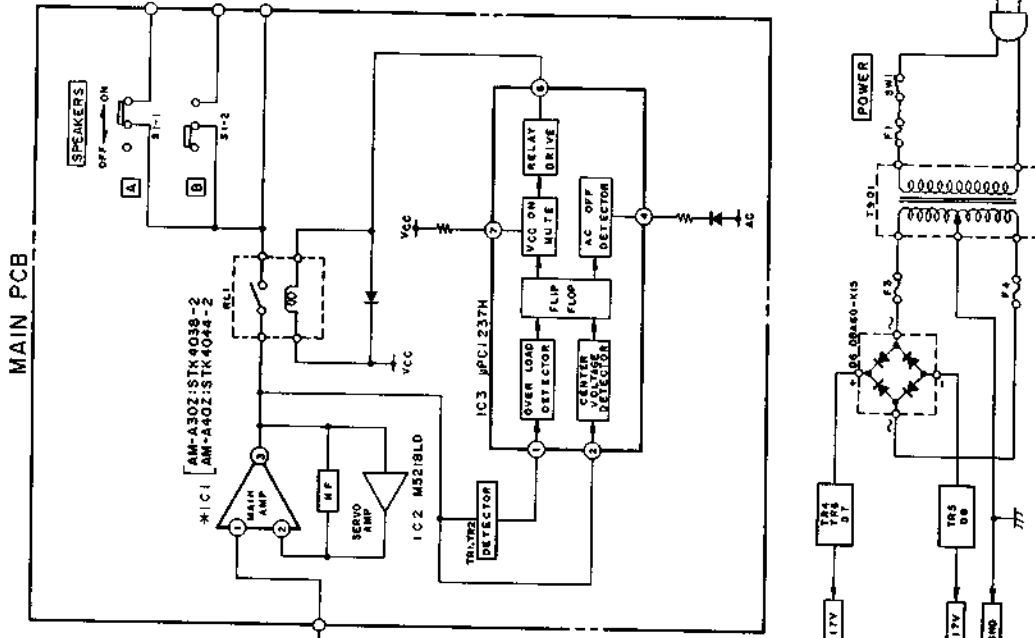
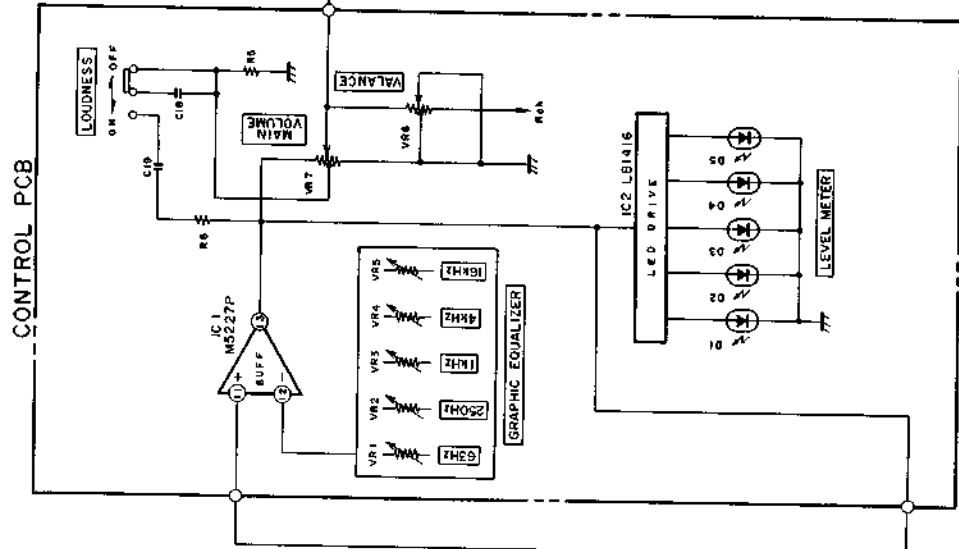
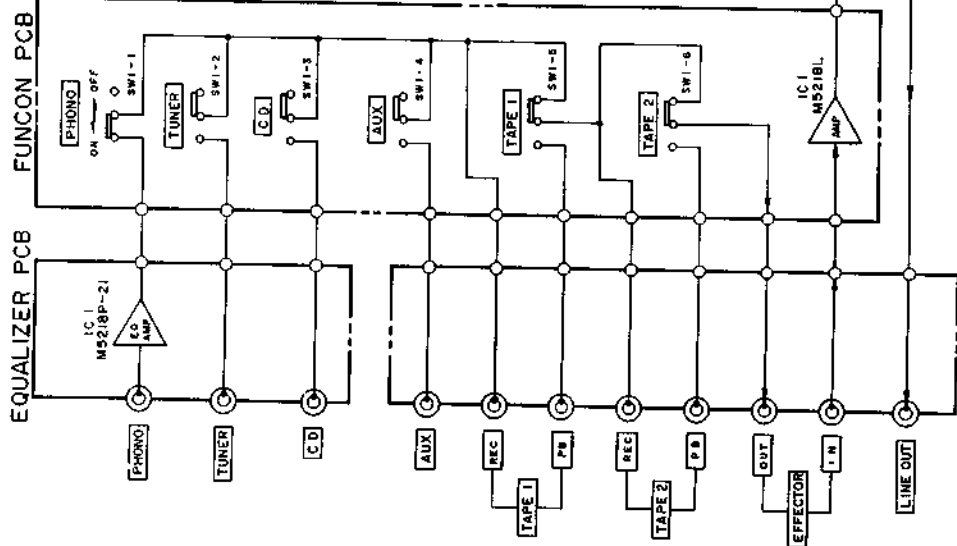

For Service Manuals Contact  
**MAURITRON TECHNICAL SERVICES**  
 8 Cherry Tree Rd, Chinnor  
 Oxon OX9 4QY  
 Tel: 01844-351694 Fax: 01844-352554  
 Email: enquiries@mauritron.co.uk

**AM-A302/402**  
**BLOCK DIAGRAM**  
 No. 860613A

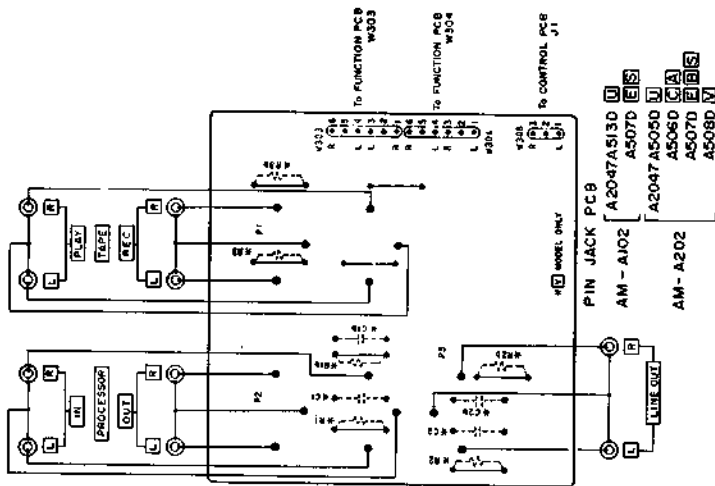
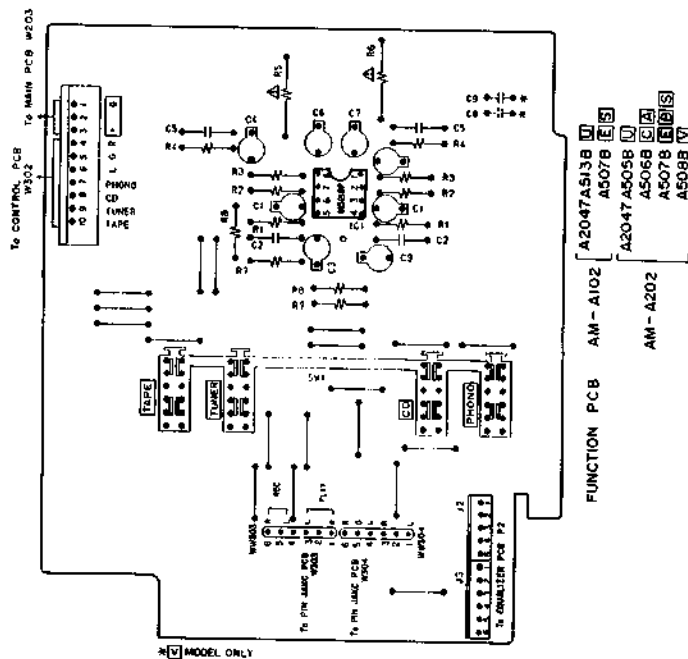
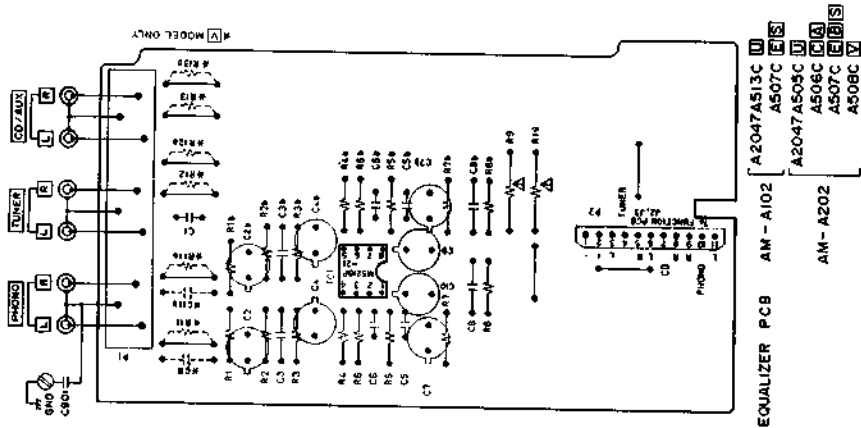

WARNING:  $\Delta$  INDICATES SAFETY CRITICAL COMPONENTS FOR CONTINUED SAFETY. REPLACE SAFETY CRITICAL COMPONENTS ONLY WITH MANUFACTURER'S RECOMMENDED PARTS.  
 AVERTISSEMENT:  $\Delta$  IL INDIQUE LES COMPOSANTS CRITIQUES DE SÉCURITÉ. POUR MAINTENIR LE DEGRÉ DE SÉCURITÉ DE L'APPAREIL, NE REMPLACER QUE DES PIÈCES RECOMMANDÉES PAR LE FABRICANT.

For Service Manuals Contact  
**MAURITRON TECHNICAL SERVICES**  
 8 Cherry Tree Rd, Chinnor  
 Oxon OX9 4QY  
 Tel: 01844-351694 Fax: 01844-352554  
 Email: enquiries@mauritron.co.uk

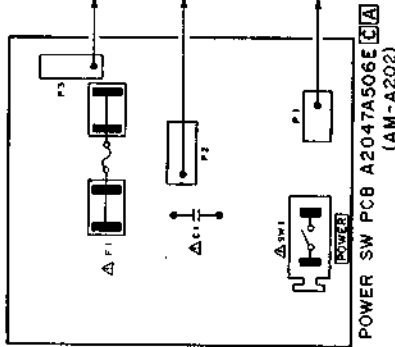

POWER SW PCB A2047A506E (AM-A202)

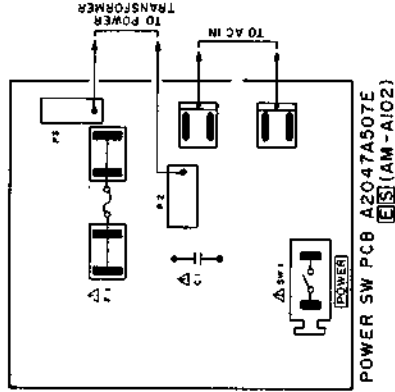

POWER SW PCB A2047A507E (AM-A102)

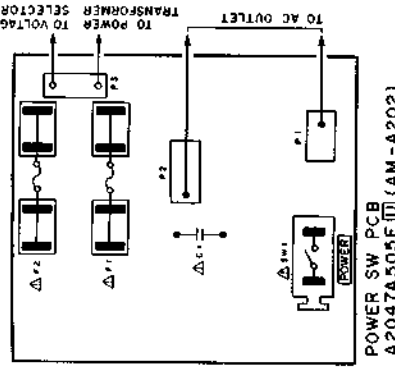

POWER SW PCB A2047A505E (AM-A202)  
A513E (AM-A102)

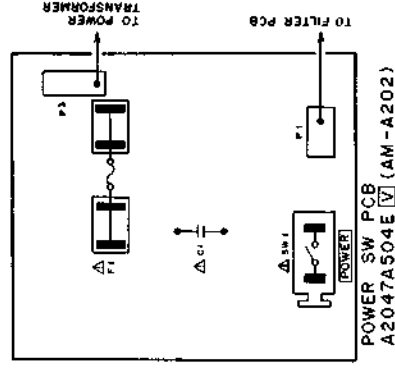

POWER SW PCB A2047A504E (AM-A202)

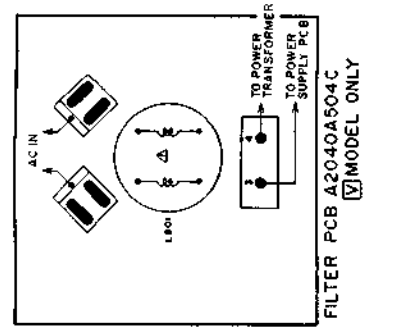

FILTER PCB A2040A504C (MODEL ONLY)

For Service Manuals Contact  
**MAURITRON TECHNICAL SERVICES**  
 8 Cherry Tree Rd, Chinnor  
 Oxon OX9 4QY  
 Tel: 01844-361694 Fax: 01844-352554  
 Email: enquiries@mauritron.co.uk

WARNING:  $\Delta$  INDICATES SAFETY CRITICAL COMPONENTS FOR CONTINUED SAFETY.  
 REPLACE SAFETY CRITICAL COMPONENTS ONLY WITH MANUFACTURER'S  
 RECOMMENDED PARTS  
 AVERTISSEMENT:  $\Delta$  IL INDIQUE LES COMPOSANTS CRITIQUES DE SÉCURITÉ.  
 POUR MAINTENIR LE DEGRÉ DE SÉCURITÉ DE L'APPAREIL.  
 NE REMPLACER QUE DES PIÈCES RECOMMANDÉES PAR LE FABRICANT

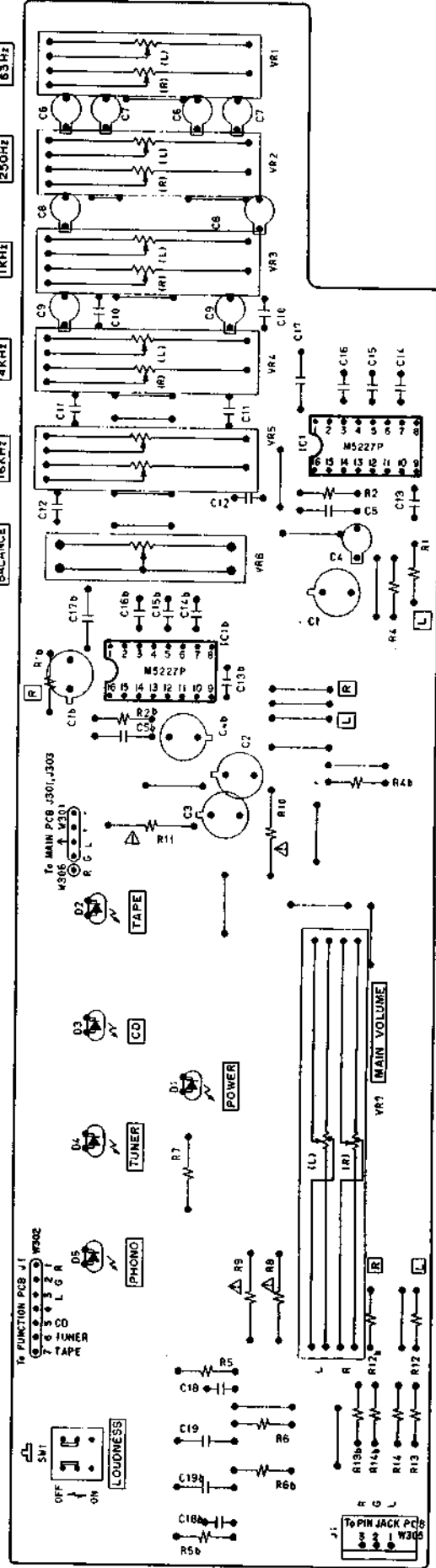

- CONTROL PCB AM-A102
- A2047A513A  $\Delta$
  - A507A  $\Delta$
  - A507A  $\Delta$
  - A506A  $\Delta$
  - A507A  $\Delta$
  - A508A  $\Delta$
- AM-A202



**HEADPHONE PCB**

- A2040A511D [U] [V] [E] [S]
- A512D [E] [S]
- AM - A202
- A2040A501D [U] [V] [E] [S]
- A502A [C] [A] [E] [S]
- A503A [E] [B] [S]
- A504A [V]

**MAIN PCB**

- AM - A102
- A2040A511A [U] [V] [E] [S]
- A512B [E] [S]
- AM - A202
- A2040A501A [U] [V] [E] [S]
- A502A [C] [A] [E] [S]
- A503A [E] [B] [S]
- A504A [V]

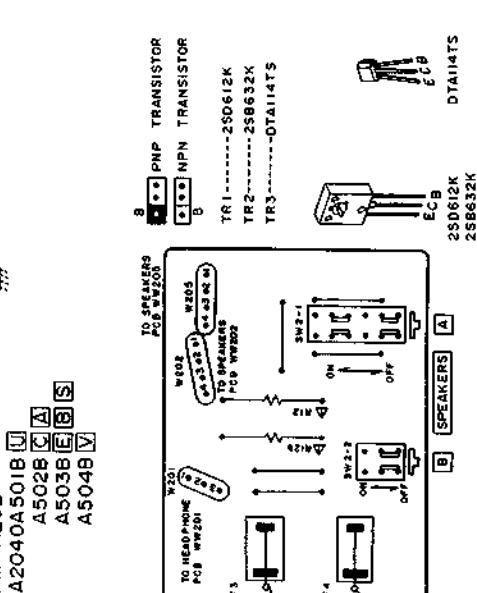
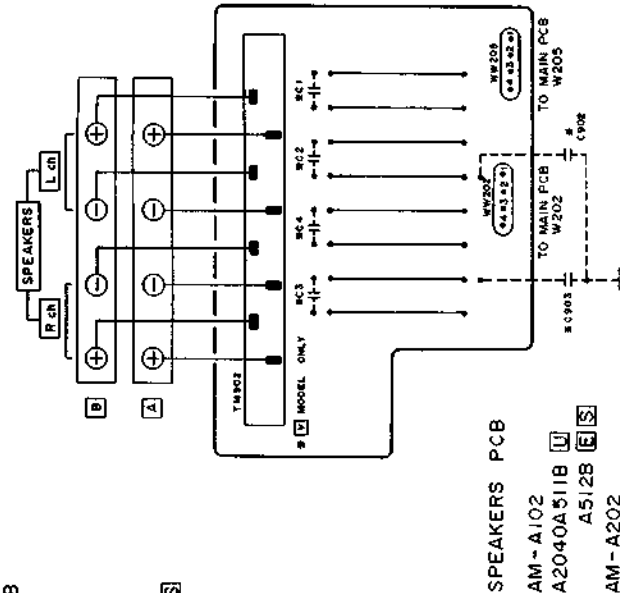
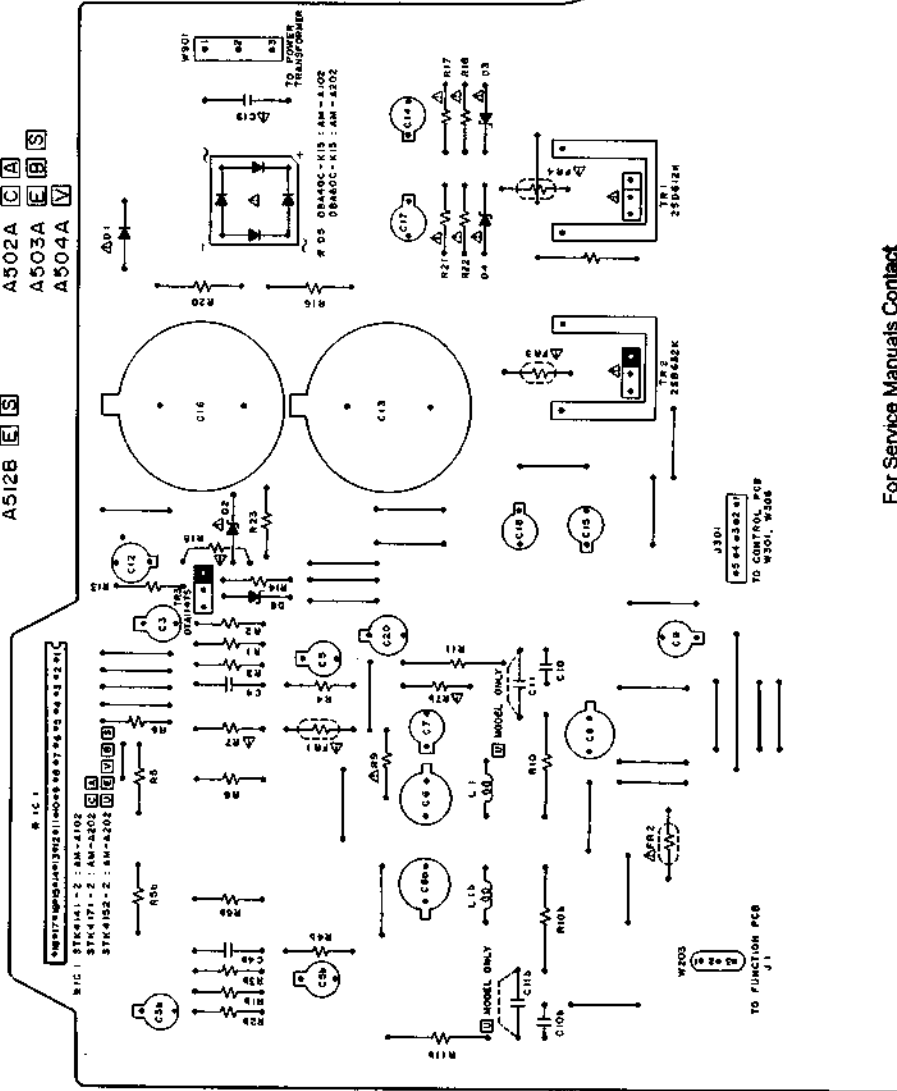

WARNING:  $\Delta$  INDICATES SAFETY CRITICAL COMPONENTS FOR CONTINUED SAFETY. REPLACE SAFETY CRITICAL COMPONENTS ONLY WITH MANUFACTURER'S RECOMMENDED PARTS.  
 AVERTISSEMENT:  $\Delta$  IL INDIQUE LES COMPOSANTS CRITIQUES DE SÉCURITÉ. POUR MAINTENIR LE DEGRÉ DE SÉCURITÉ DE L'APPAREIL, NE REMPLACER QUE DES PIÈCES RECOMMANDÉES PAR LE FABRICANT.

For Service Manuals Contact  
**MAURITRON TECHNICAL SERVICES**  
 8 Cherry Tree Rd, Chinnor  
 Oxon OX9 4QY  
 Tel: 01844-351694 Fax: 01844-352554  
 Email: enquiries@mauritron.co.uk

AM-A102/202

For Service Manuals Contact  
**MAURITRON TECHNICAL SERVICES**  
 8 Cherry Tree Rd, Chinnor  
 Oxon OX9 4QY  
 Tel: 01844-351694 Fax: 01844-352554  
 Email: enquiries@mauritron.co.uk

EQUALIZER PCB

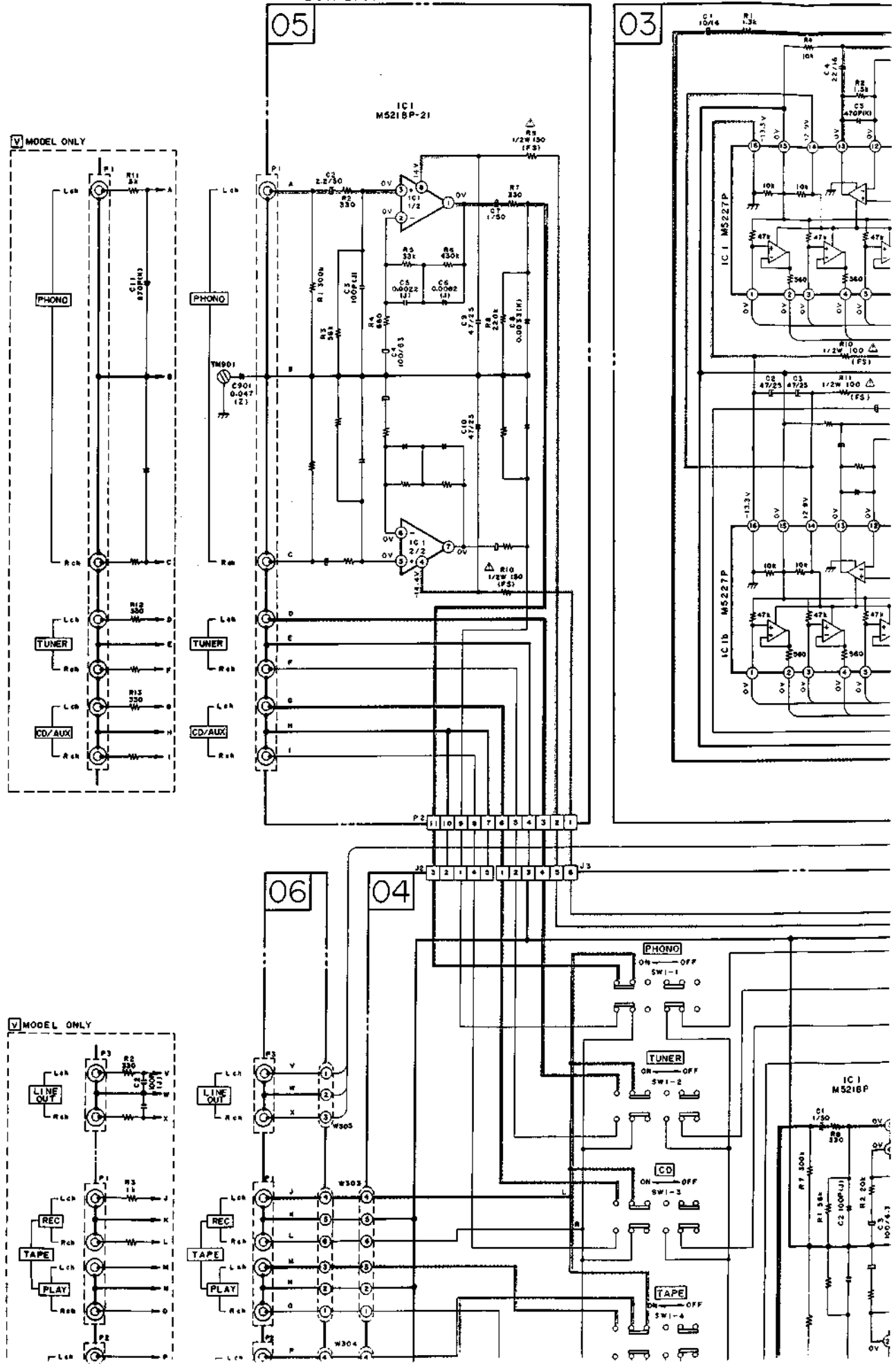

ER PCB

03

GRAPHIC EQUALIZER

LOUDNESS

IC1 M5216P-21

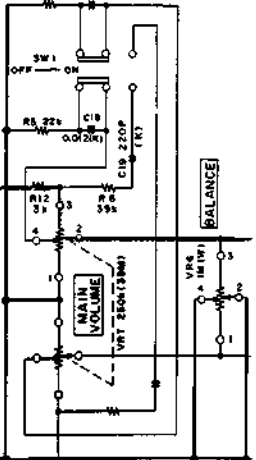
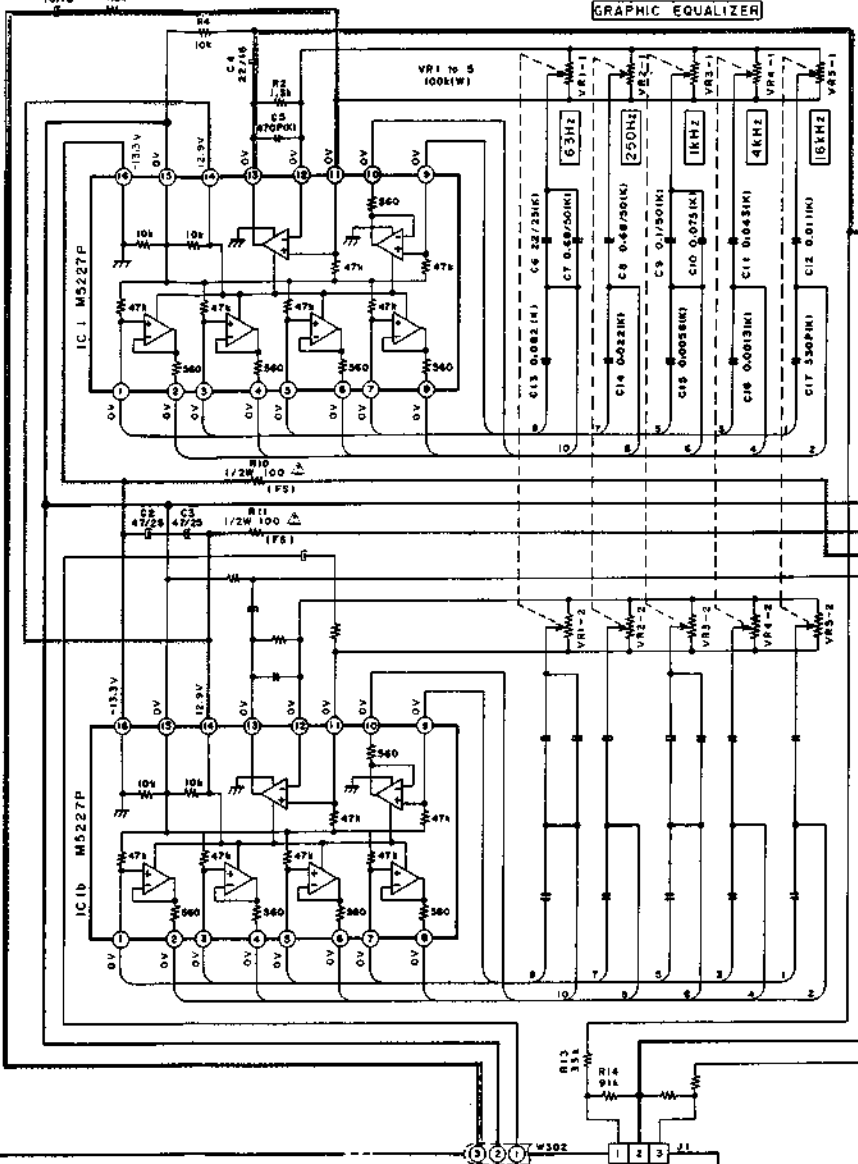
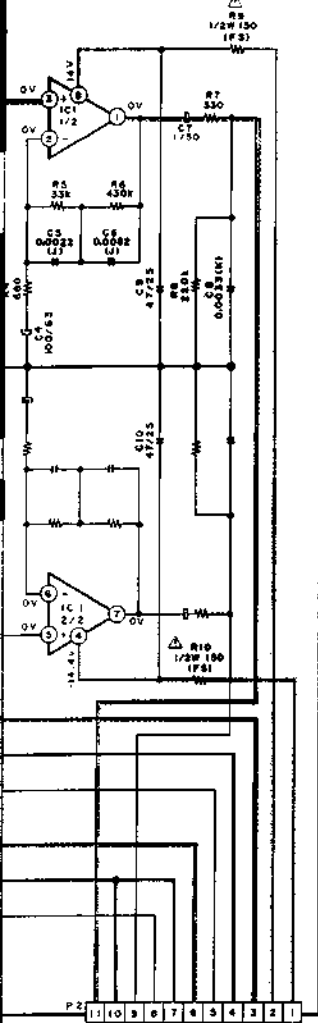

04

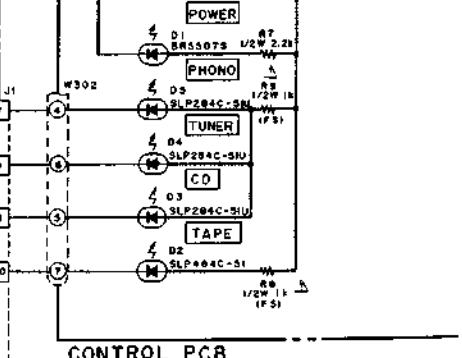
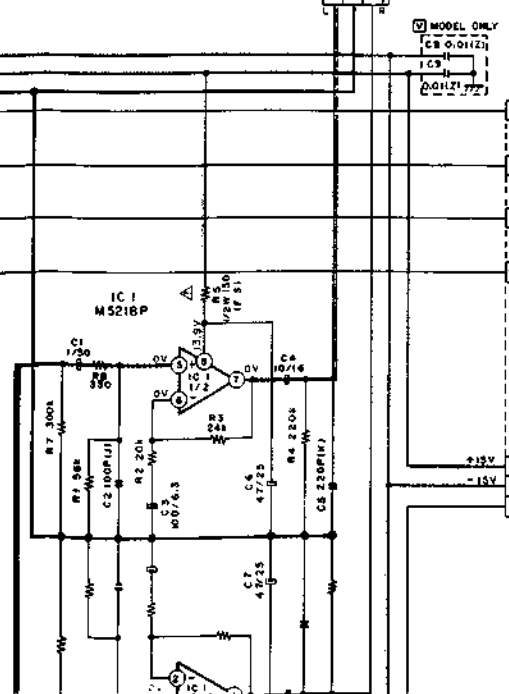
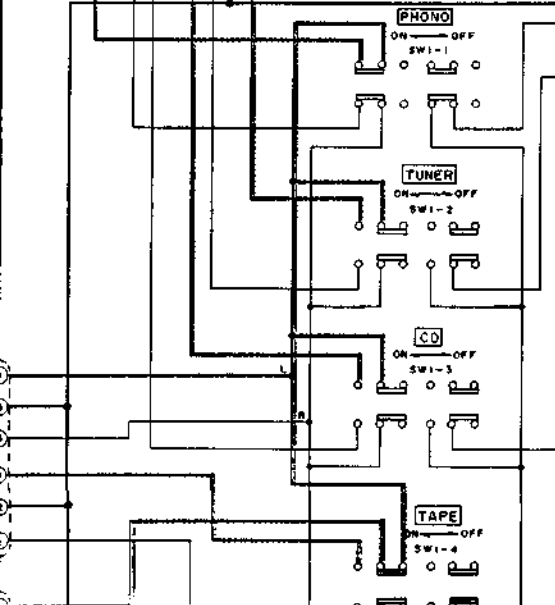

CONTROL PCB

POWER SW PCB

FILTER

09

POWER

FILTER

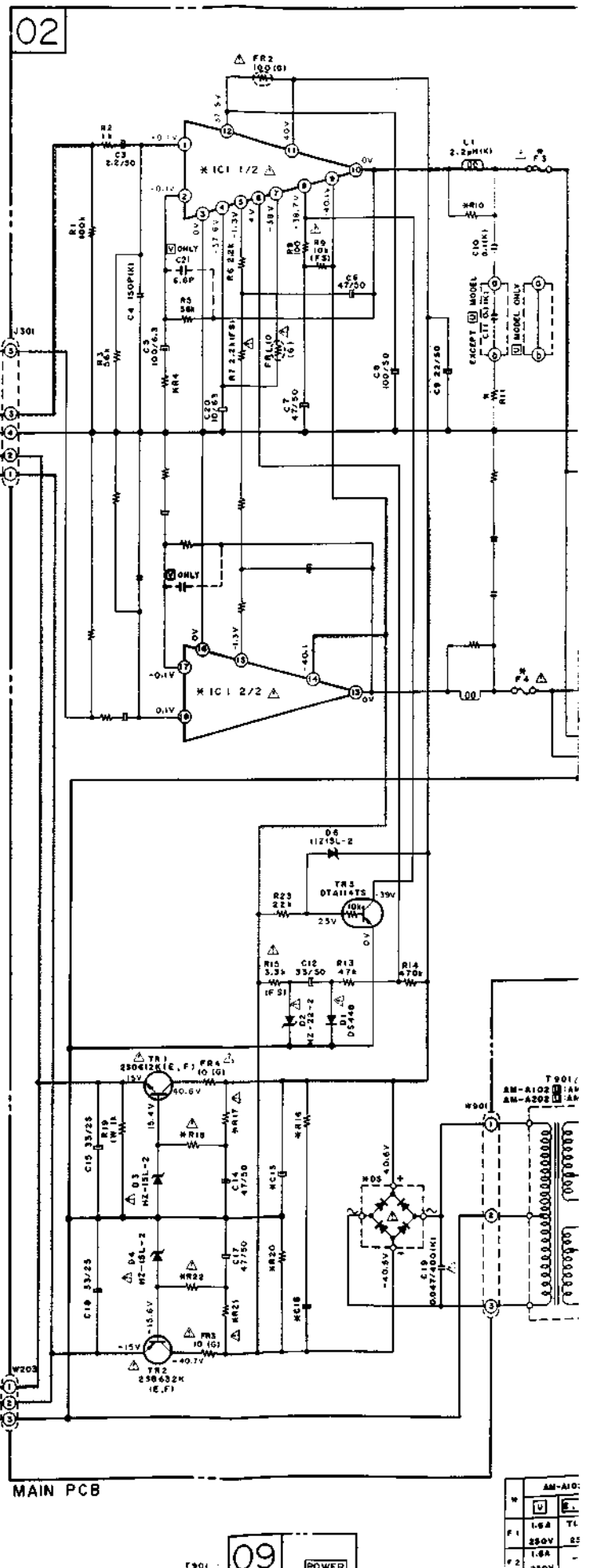
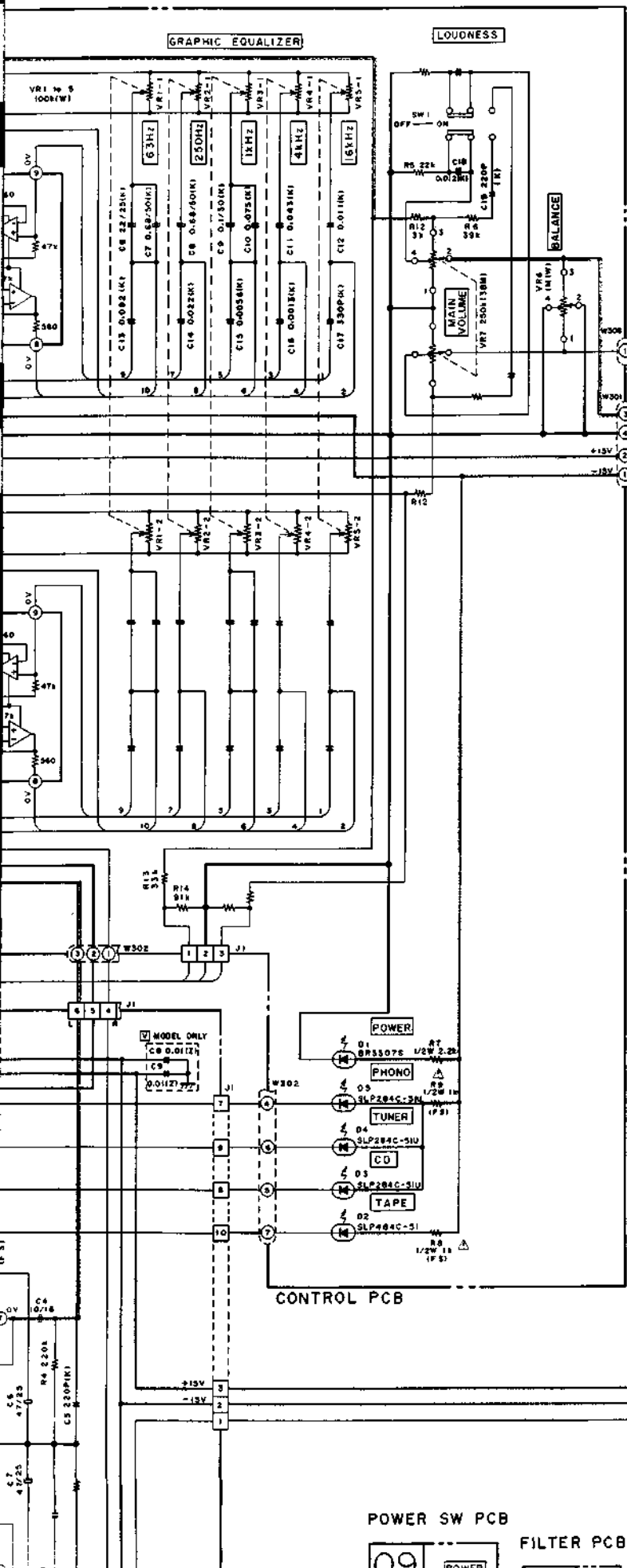

POWER SW PCB FILTER PCB

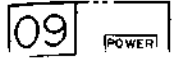

W	U	F	T	ES
1.6A	1.6A	1.6A	1.6A	1.6A
25V	25V	25V	25V	25V
1.6A	1.6A	1.6A	1.6A	1.6A
25V	25V	25V	25V	25V

For Service Manuals Contact  
**MAURITRON TECHNICAL SERVICES**  
 8 Cherry Tree Rd, Chinnor  
 Oxon OX9 4QY  
 Tel: 01844-351694 Fax: 01844-352554  
 Email: enquiries@mauritron.co.uk

02

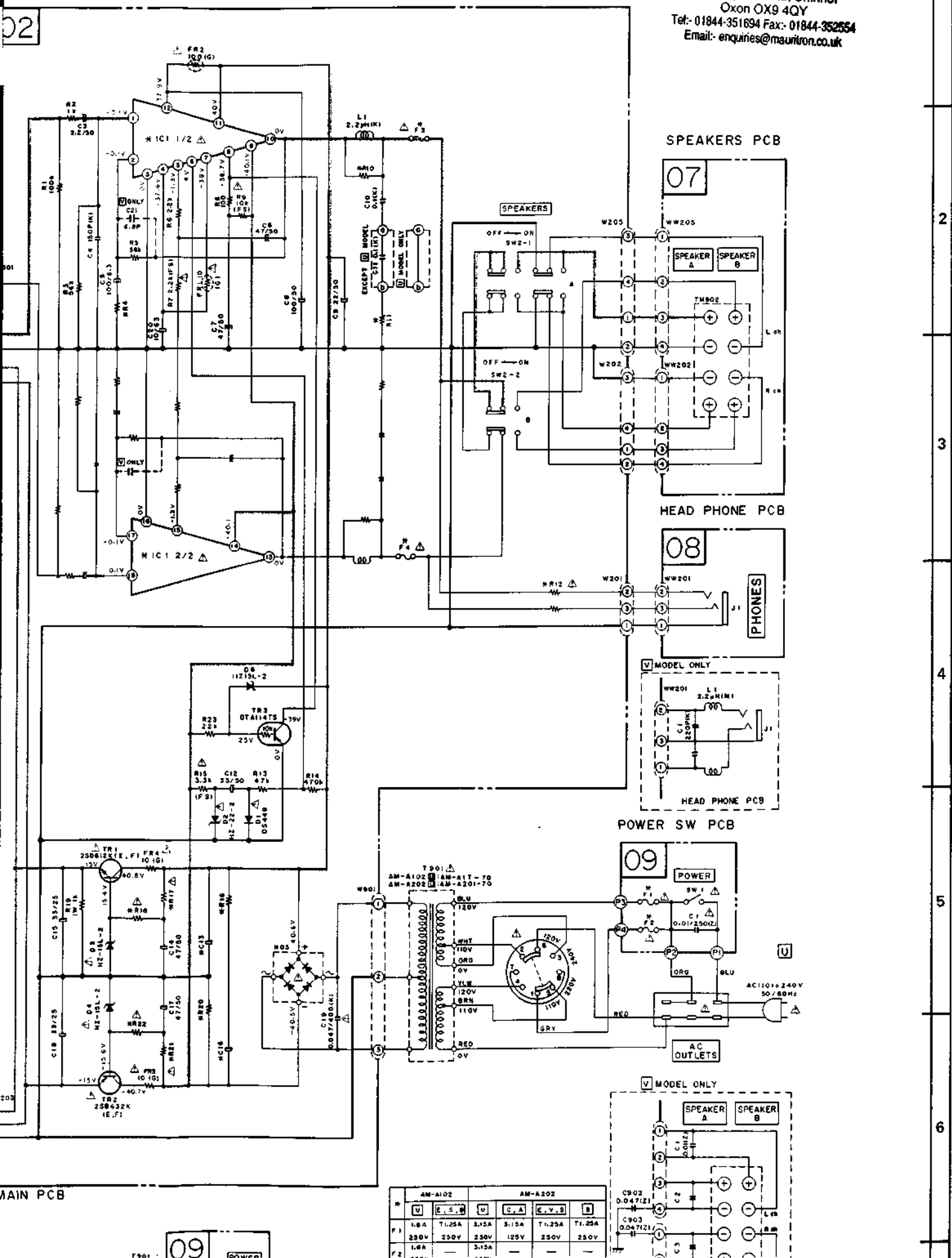

MAIN PCB

09 POWER

*	AM-A102			AM-A202		
	V	E.S.W	U	C.A	E.V.S	B
F1	1.6A	T1.25A	3.15A	3.15A	T1.25A	T1.25A
F2	250V	250V	250V	125V	250V	250V
F3	1.6A	—	3.15A	—	—	—
F4	250V	—	250V	—	—	—

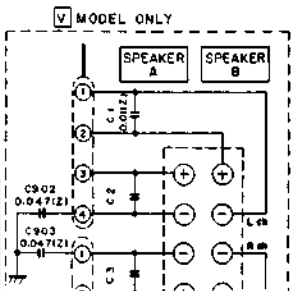

POWER SW PCB

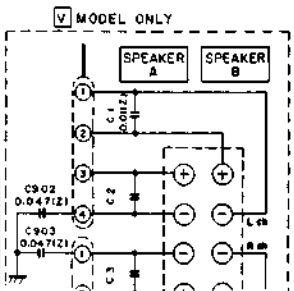
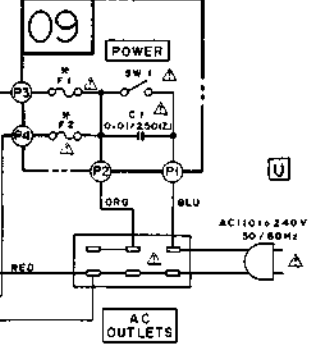

1  
2  
3  
4  
5  
6

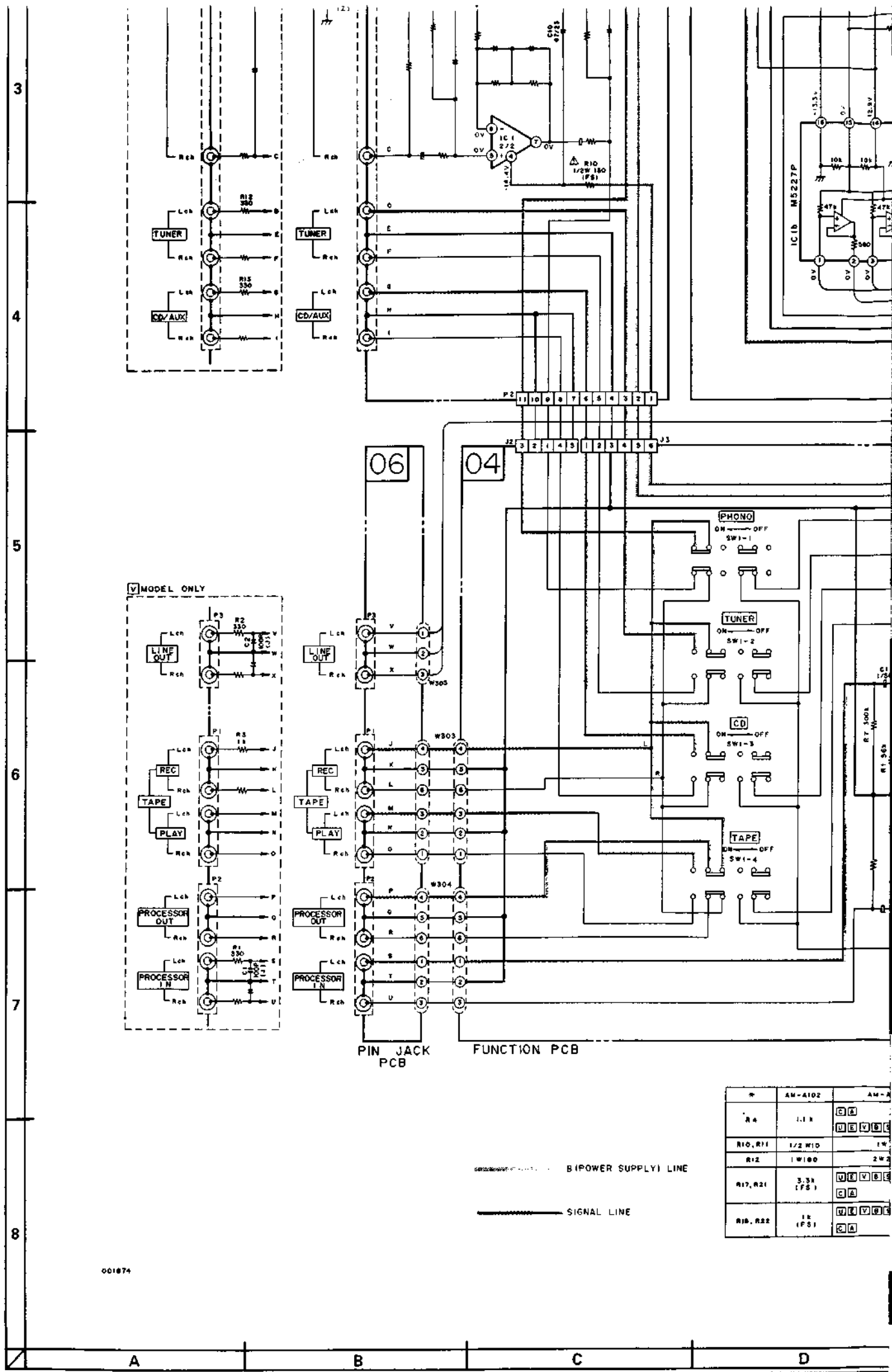

3

4

5

6

7

8

V MODEL ONLY

06

04

PIN JACK PCB

FUNCTION PCB

*	AM-A102	AM-A
R4	1.1K	□ □
R10, R11	1/2W 180	□ □ □ □ □ □
R12	1W 100	□ □ □ □ □ □
R17, R21	3.3K (FS)	□ □ □ □ □ □
R18, R22	1K (FS)	□ □ □ □ □ □

— (POWER SUPPLY) LINE

— SIGNAL LINE

001874

A

B

C

D

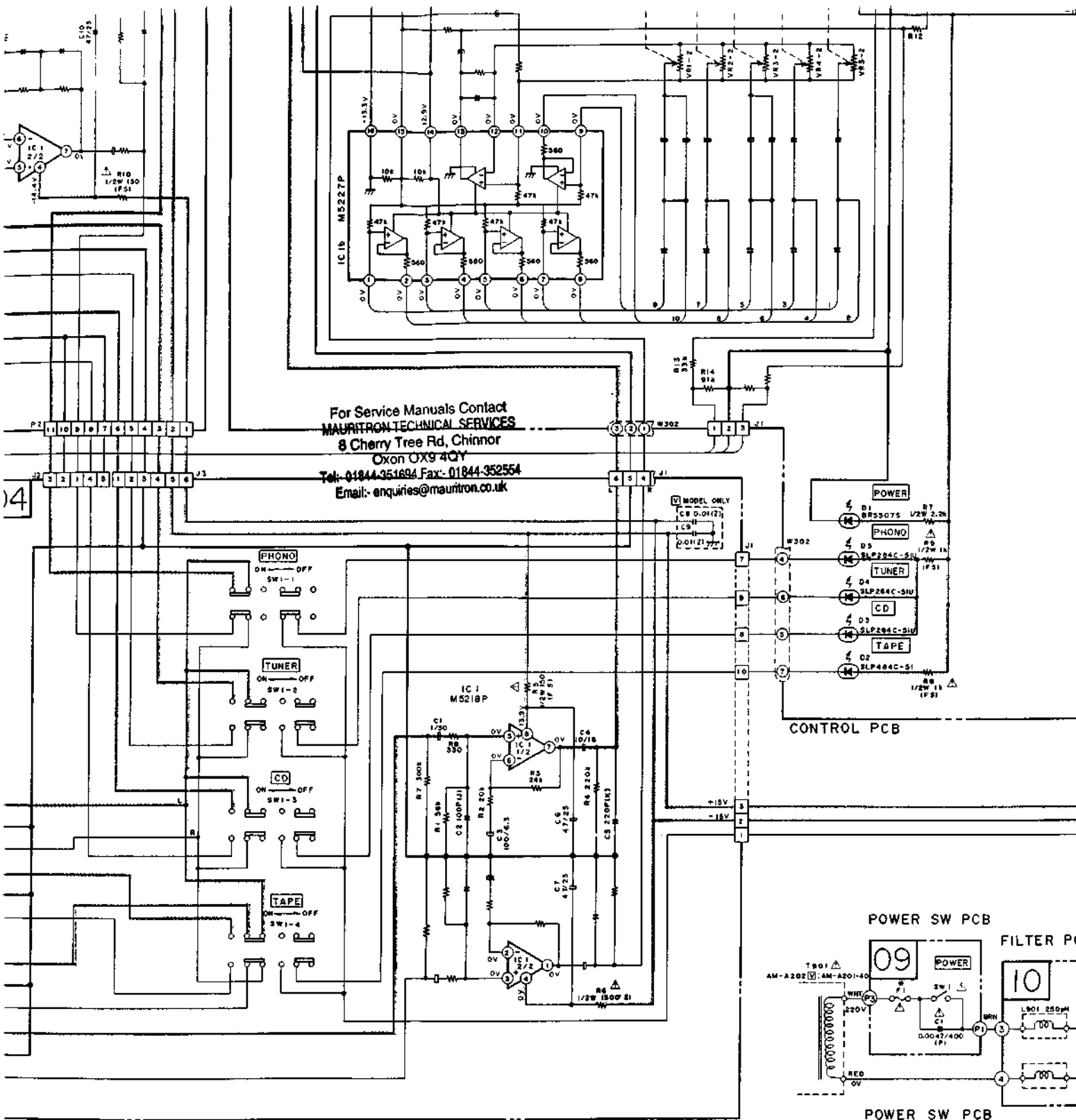

UNCTION PCB

P	AM-A102	AM-A202	A	AM-A102	AM-A202
R4	1.1k	750	R16, R20	5.6k	10k
R10, R11	1/2W 150 (F5)	1W10	C15, C16	4700/40	4700/45
R12	1W100	2W220	D5	DBA40C-K15	DBA60C-K15
R17, R21	3.3k (F5)	3.3k (F5)	IC1	STK4171-2	STK4171-2
R18, R22	1k (F5)	1.0k (F5)		STK4152-2	STK4152-2

8 (POWER SUPPLY) LINE

SIGNAL LINE

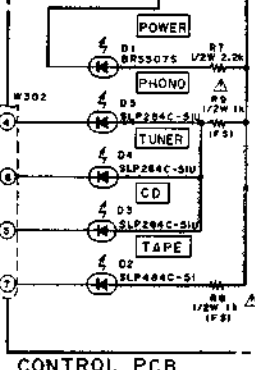

CONTROL PCB

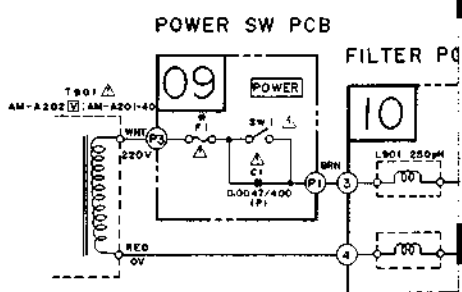

POWER SW PCB

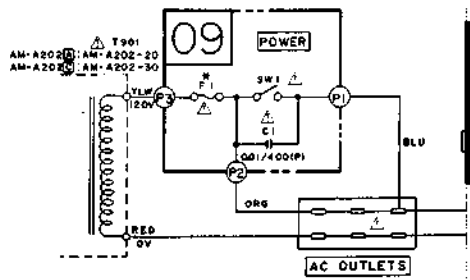

AC OUTLETS

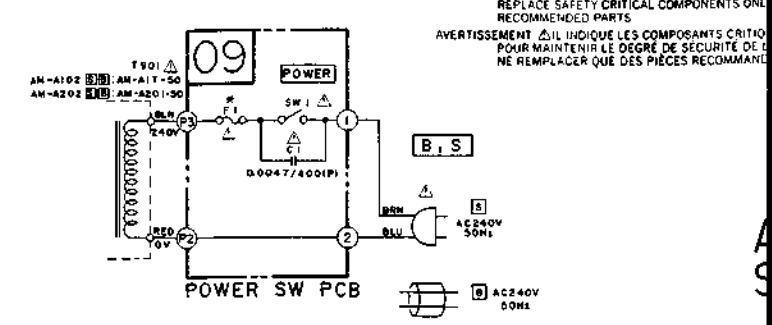
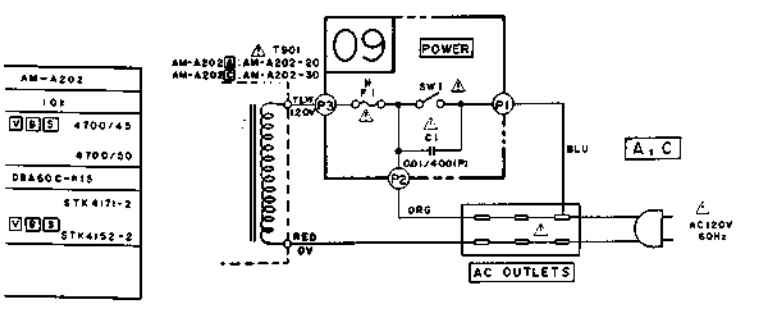
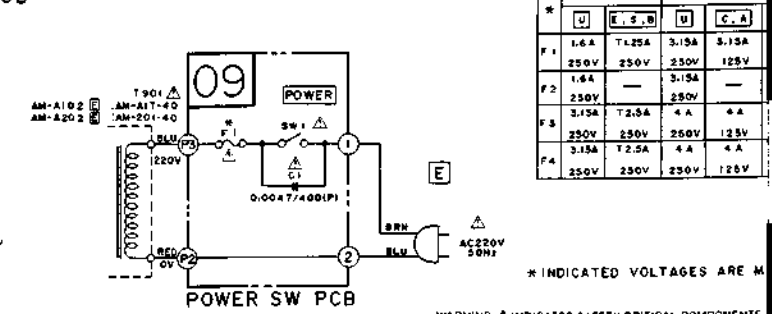
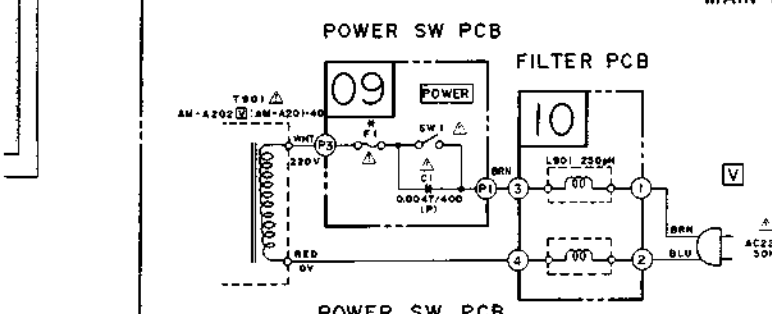
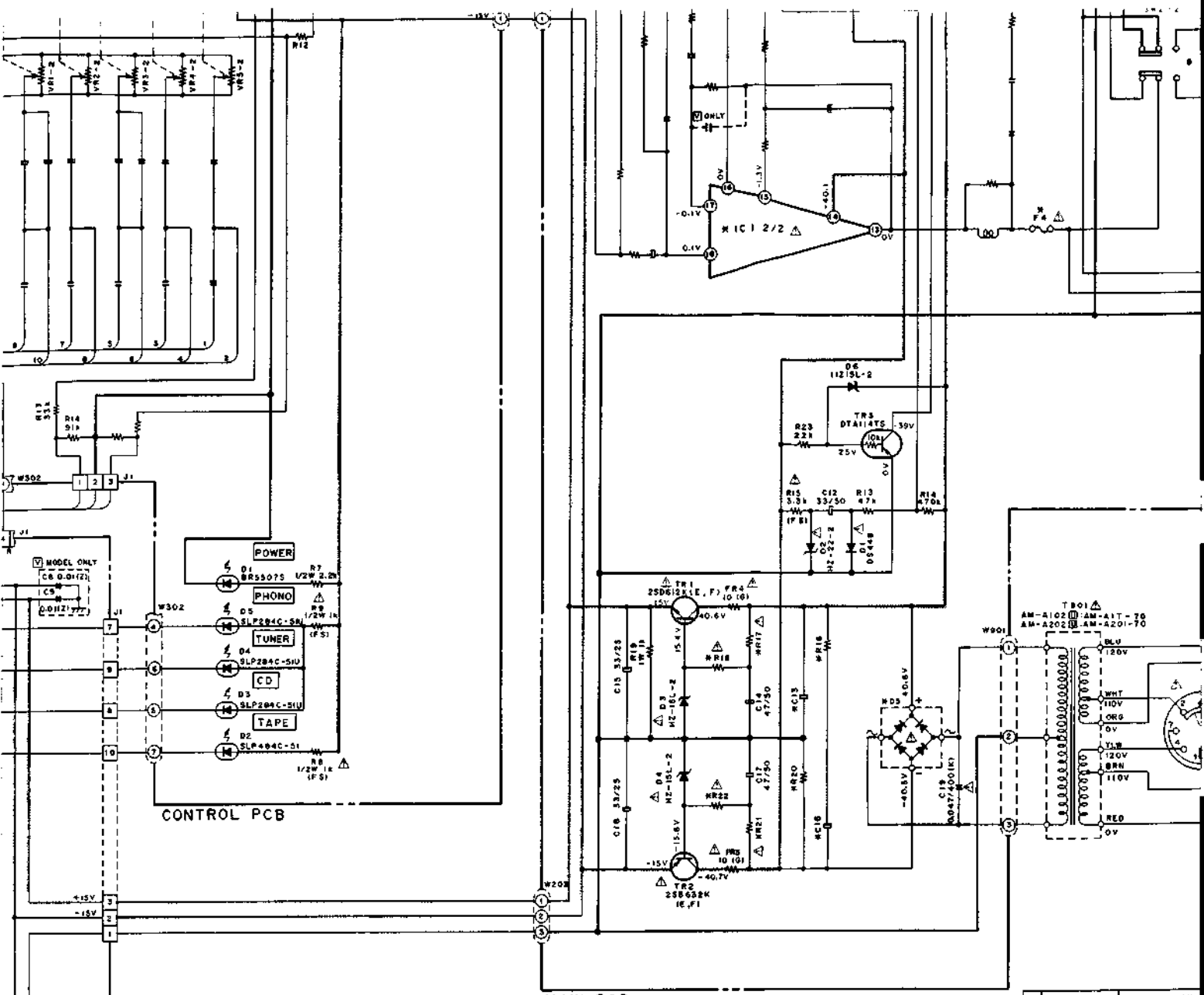

*	AM-A102		AM-	
	U	E, S, B	U	C, A
F1	1.6 A	T1.25A	3.15A	3.15A
F2	1.8 A	—	3.15A	—
F3	3.15A	T2.5A	4 A	4 A
F4	3.15A	T2.5A	4 A	4 A

\* INDICATED VOLTAGES ARE MAX

WARNING: Δ INDICATES SAFETY CRITICAL COMPONENTS  
REPLACE SAFETY CRITICAL COMPONENTS ONLY  
RECOMMENDED PARTS

AVERTISSEMENT: Δ IL INDIQUE LES COMPOSANTS CRITIQUE  
POUR MAINTENIR LE DEGRÉ DE SÉCURITÉ DE L'APPAREIL  
NE REMPLACER QUE DES PIÈCES RECOMMANDÉES

AM-A202	
10X	
4700/45	
4700/50	
DR60C-R15	
STK4171-2	
STK4152-2	



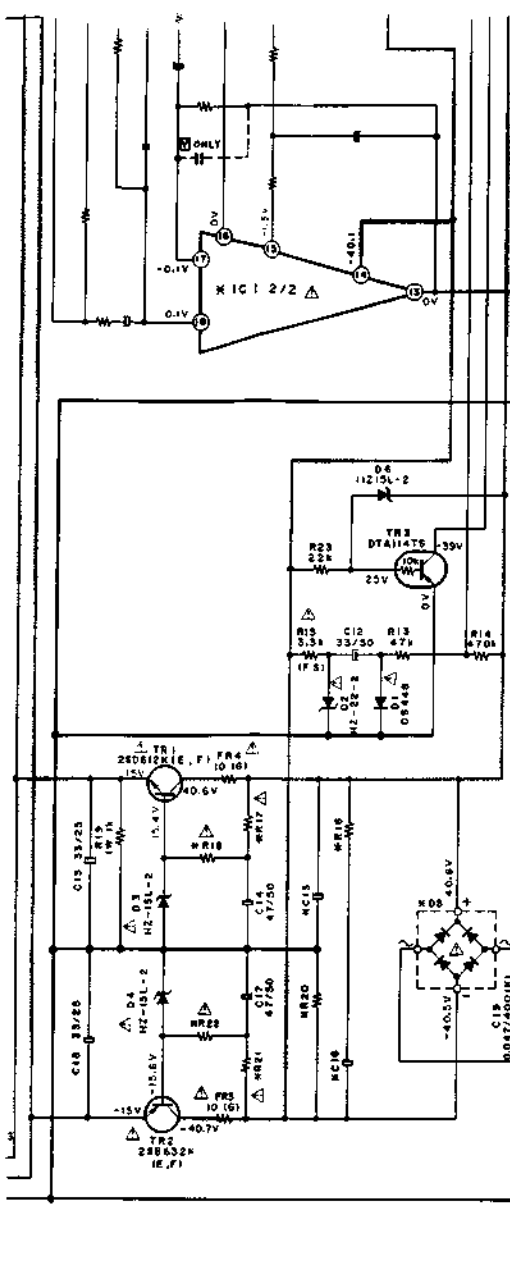

For Service Manuals Contact  
**MAURITRON TECHNICAL SERVICES**  
 8 Cherry Tree Rd, Chinnor  
 Oxon OX9 4QY  
 Tel: 01844-351694 Fax: 01844-352554  
 Email: enquiries@mauritron.co.uk

HEAD PHONE PCB

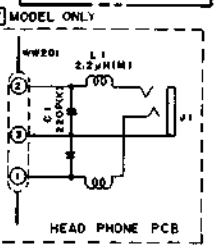
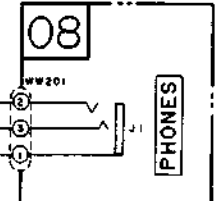

POWER SW PCB

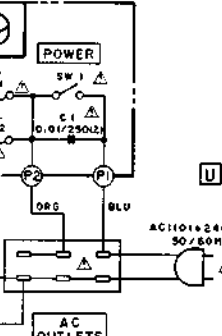

MODEL ONLY

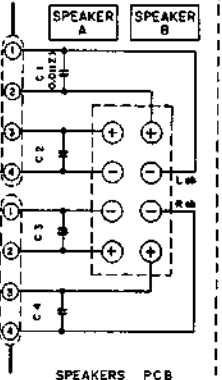

MAIN PCB

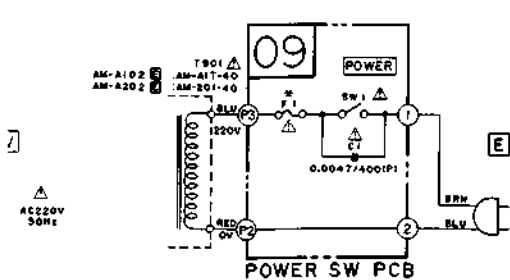

* U	AM-A102			AM-A202		
	E, S, B	V	C, A	E, V, S	T, B	S
F1	1.6A 250V	T1.25A 230V	3.15A 250V	3.15A 125V	T1.25A 250V	T1.25A 280V
F2	1.4A 230V	—	3.15A 230V	—	—	—
F3	3.15A 250V	T2.5A 230V	4 A 230V	4 A 125V	T3.15A 250V	T3.15A 250V
F4	3.15A 280V	T2.5A 250V	4 A 250V	4 A 125V	T3.15A 250V	T3.15A 280V

\* INDICATED VOLTAGES ARE MEASURED AT CO AND NO INPUT

WARNING: Δ INDICATES SAFETY CRITICAL COMPONENTS. FOR CONTINUED SAFETY, REPLACE SAFETY CRITICAL COMPONENTS ONLY WITH MANUFACTURER'S RECOMMENDED PARTS

AVERTISSEMENT: Δ IL INDIQUE LES COMPOSANTS CRITIQUES DE SÉCURITÉ POUR MAINTENIR LE DEGRÉ DE SÉCURITÉ DE L'APPAREIL, NE REPLACER QUE DES PIÈCES RECOMMANDÉES PAR LE FABRICANT

NOTE: UNLESS OTHERWISE SPECIFIED, ALL RESISTORS (IN OHMS 1/4W(J)) ALL CAPACITORS (IN μF 50WV(U)) POWER TRANSFORMER IS DIFFERENT ACCORDING TO AREA

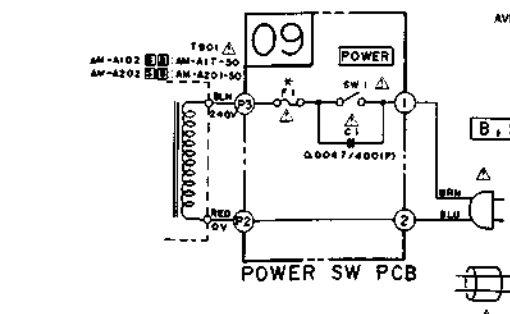

# AM-A102/202 SCHEMATIC DIAGRAM No. 860612A

AM-A302/402

EQUALIZER PCB A2048A506C

05 For Service Manuals Contact MAURITRON TECHNICAL SERVICES 8 Cherry Tree Rd, Chinnor Oxon OX9 4QY Tel: 01844-351694 Fax: 01844-352554 Email: enquiries@mauritron.co.uk IC1 M5218P-21

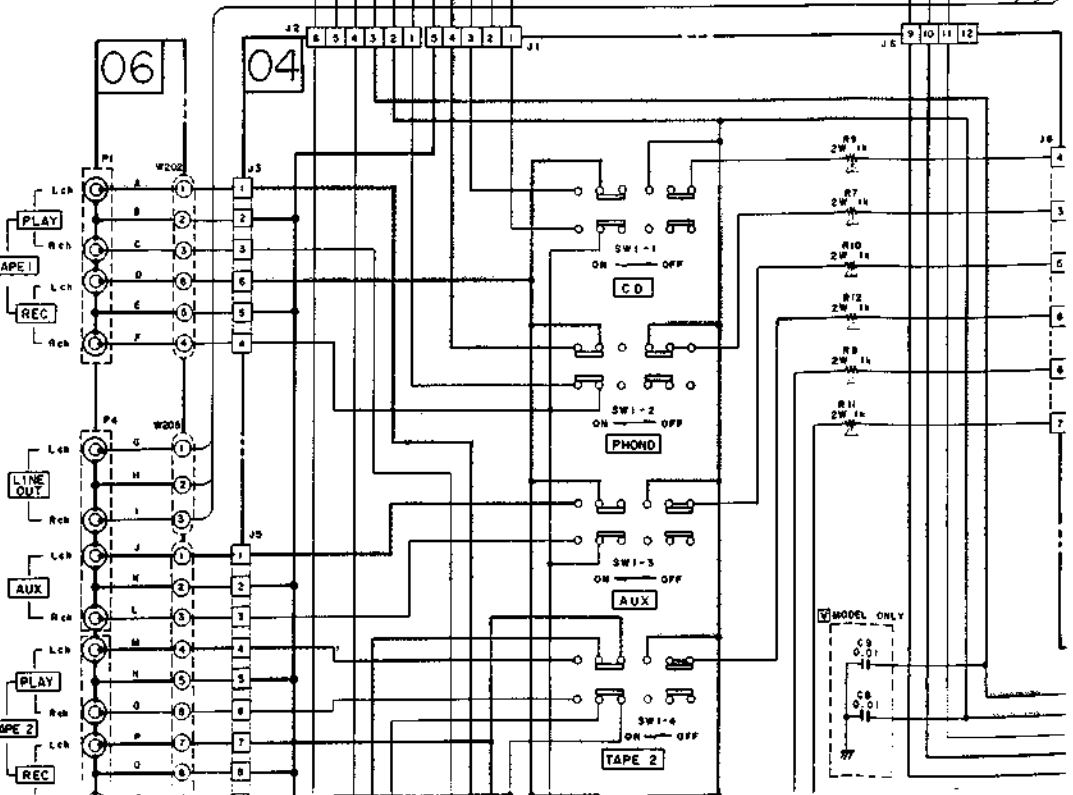
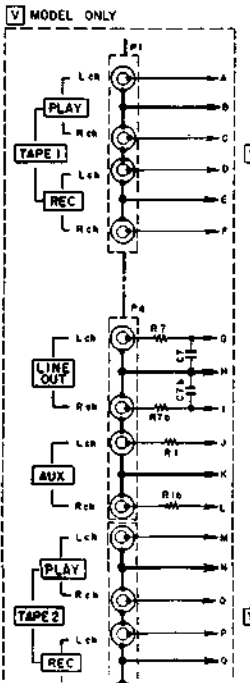
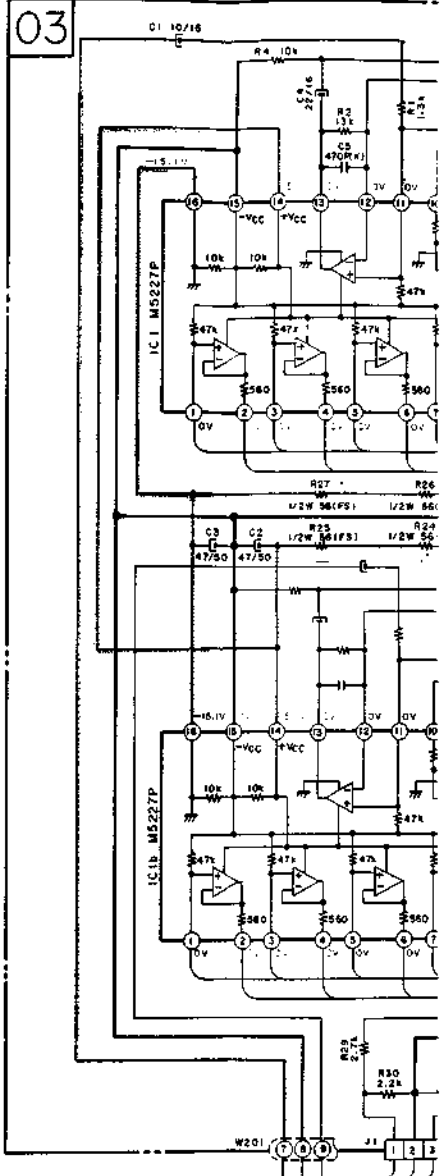
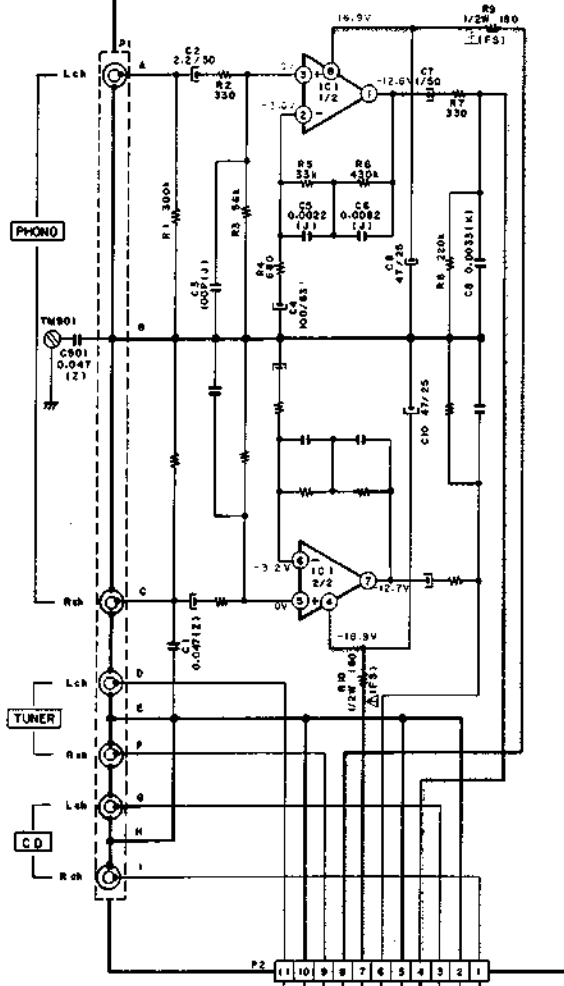
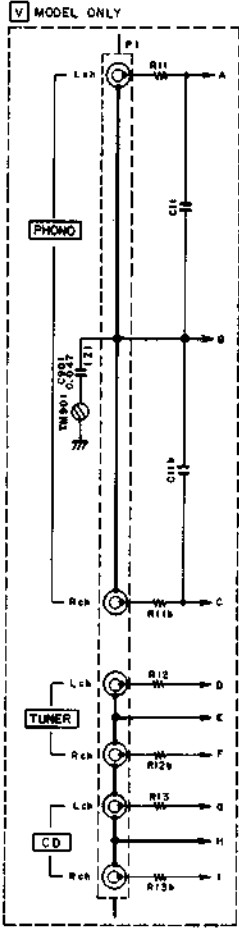

EQUALIZER PCB A2048A506C

05

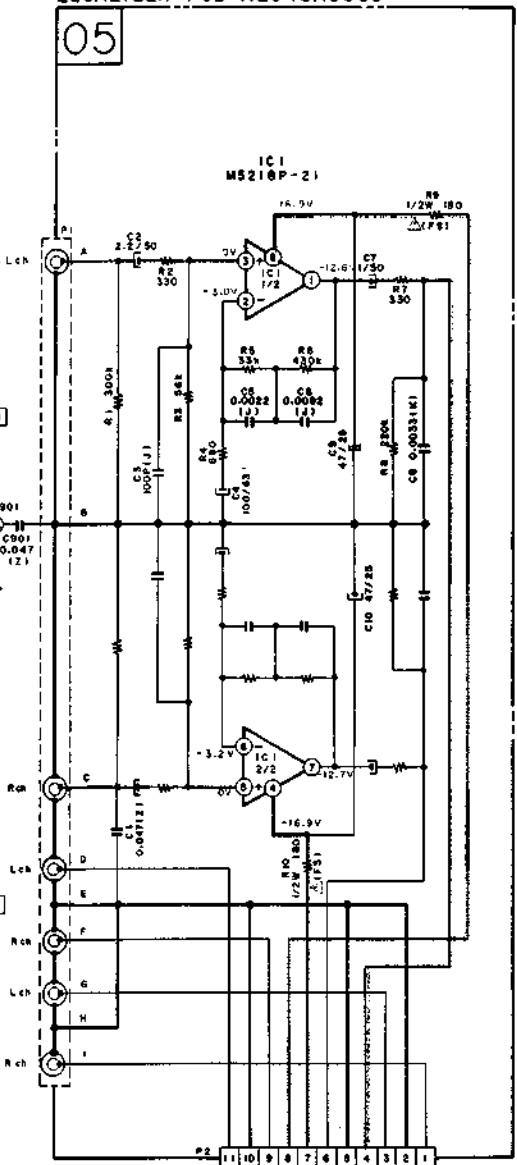

03

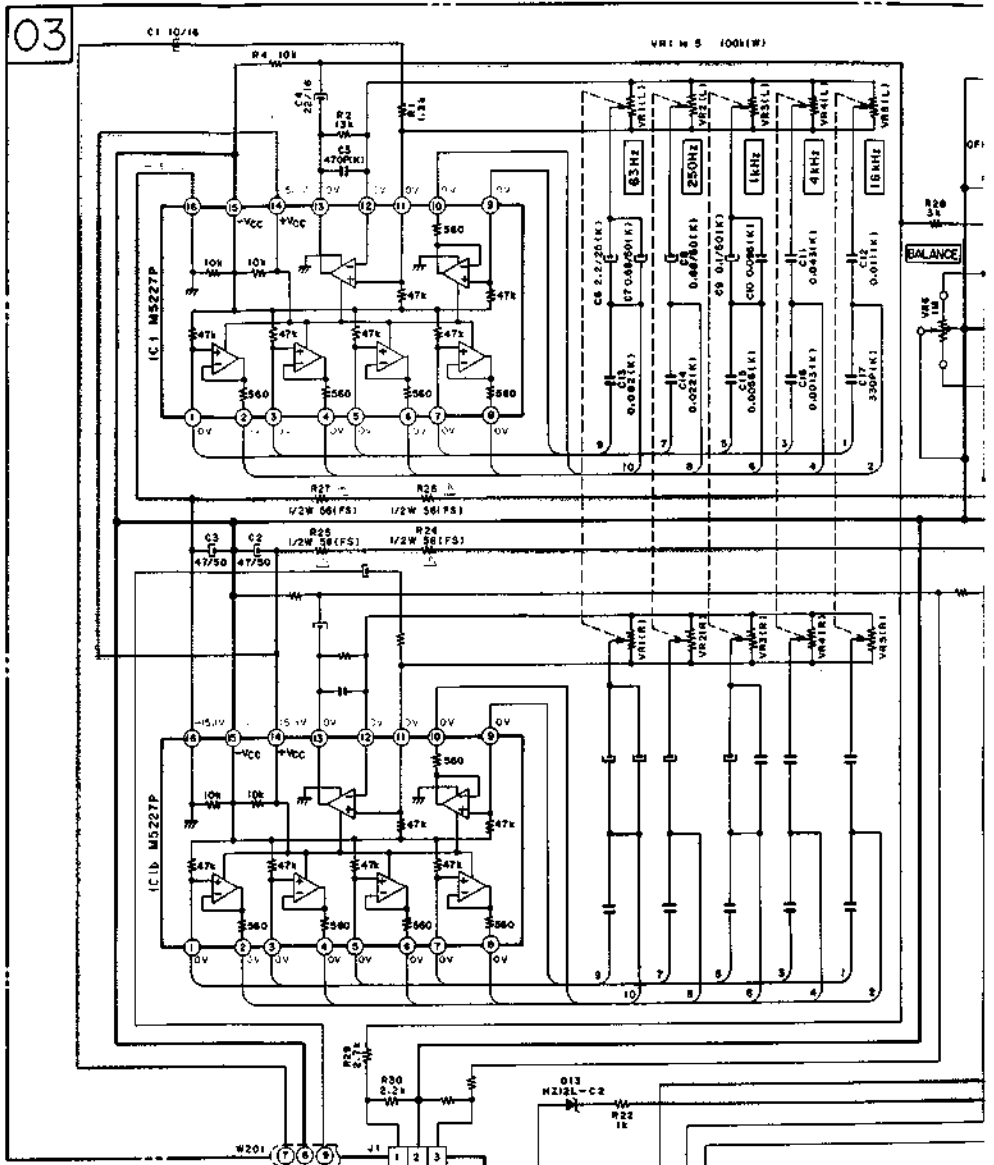

06

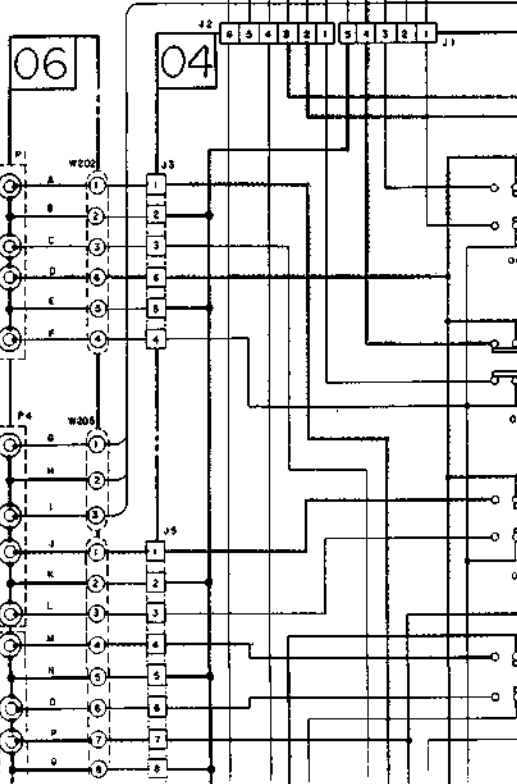

04

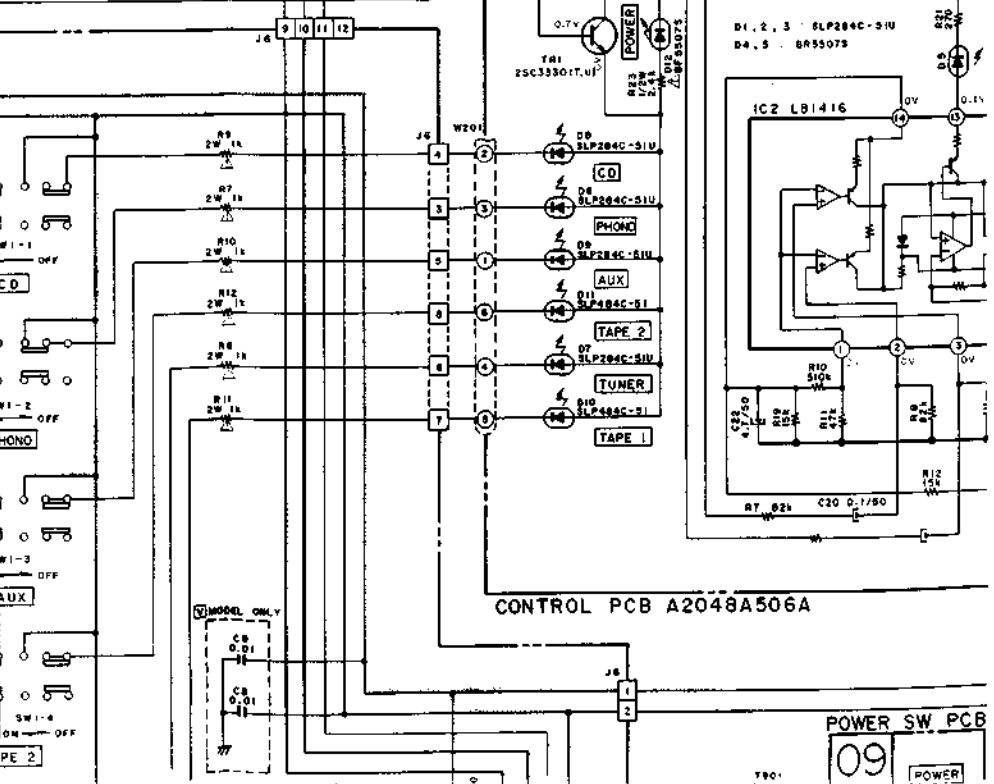

CONTROL PCB A2048A506A

POWER SW PCB

09

POWER

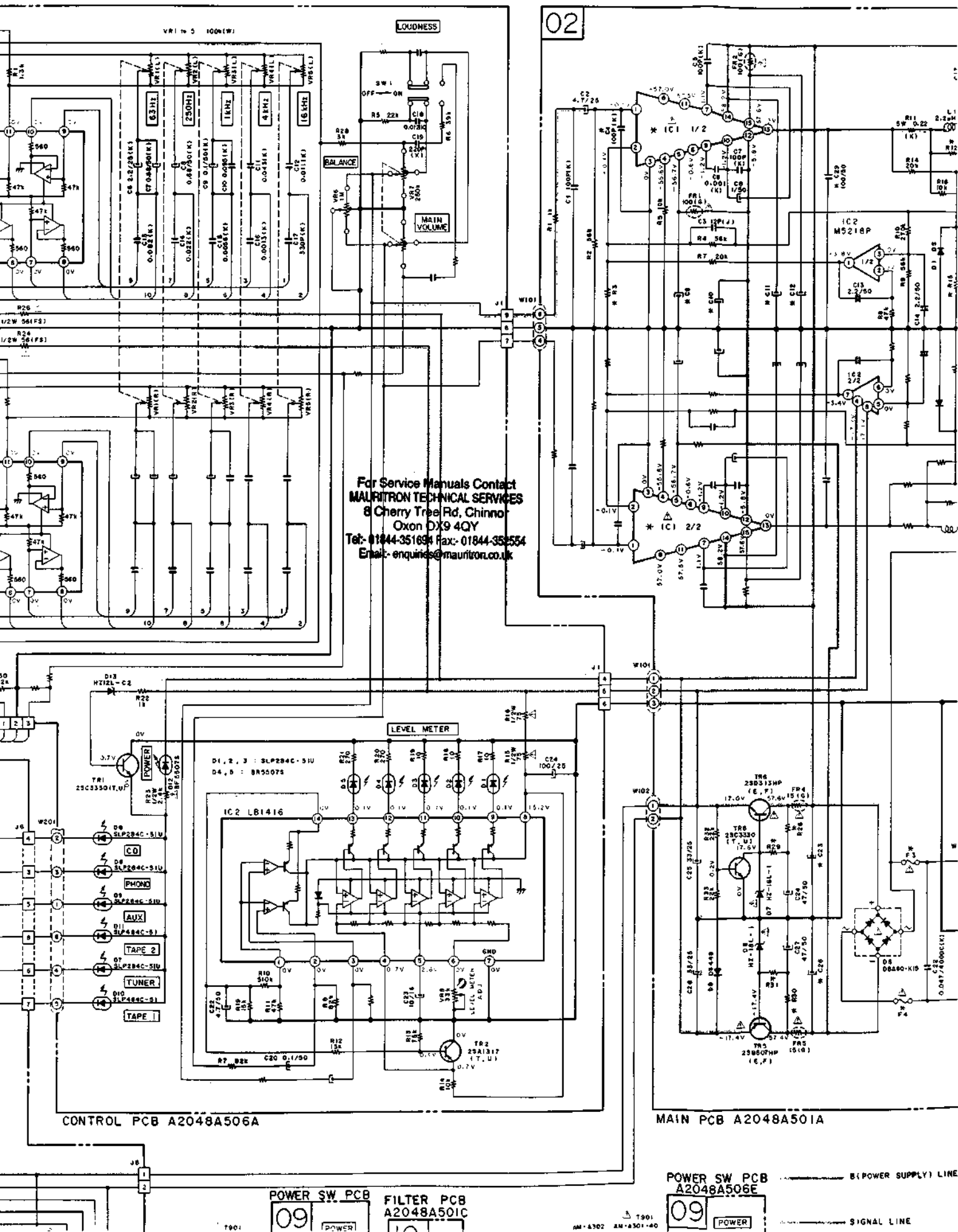

02

VRI to 5 100K(1W)

LOUDNESS

LEVEL METER

CONTROL PCB A2048A506A

MAIN PCB A2048A501A

POWER SW PCB

FILTER PCB

POWER SW PCB A2048A506E

09

POWER

09

POWER

09

POWER

SIGNAL LINE

(POWER SUPPLY) LINE

T901  
AM-4302 AM-4301-40

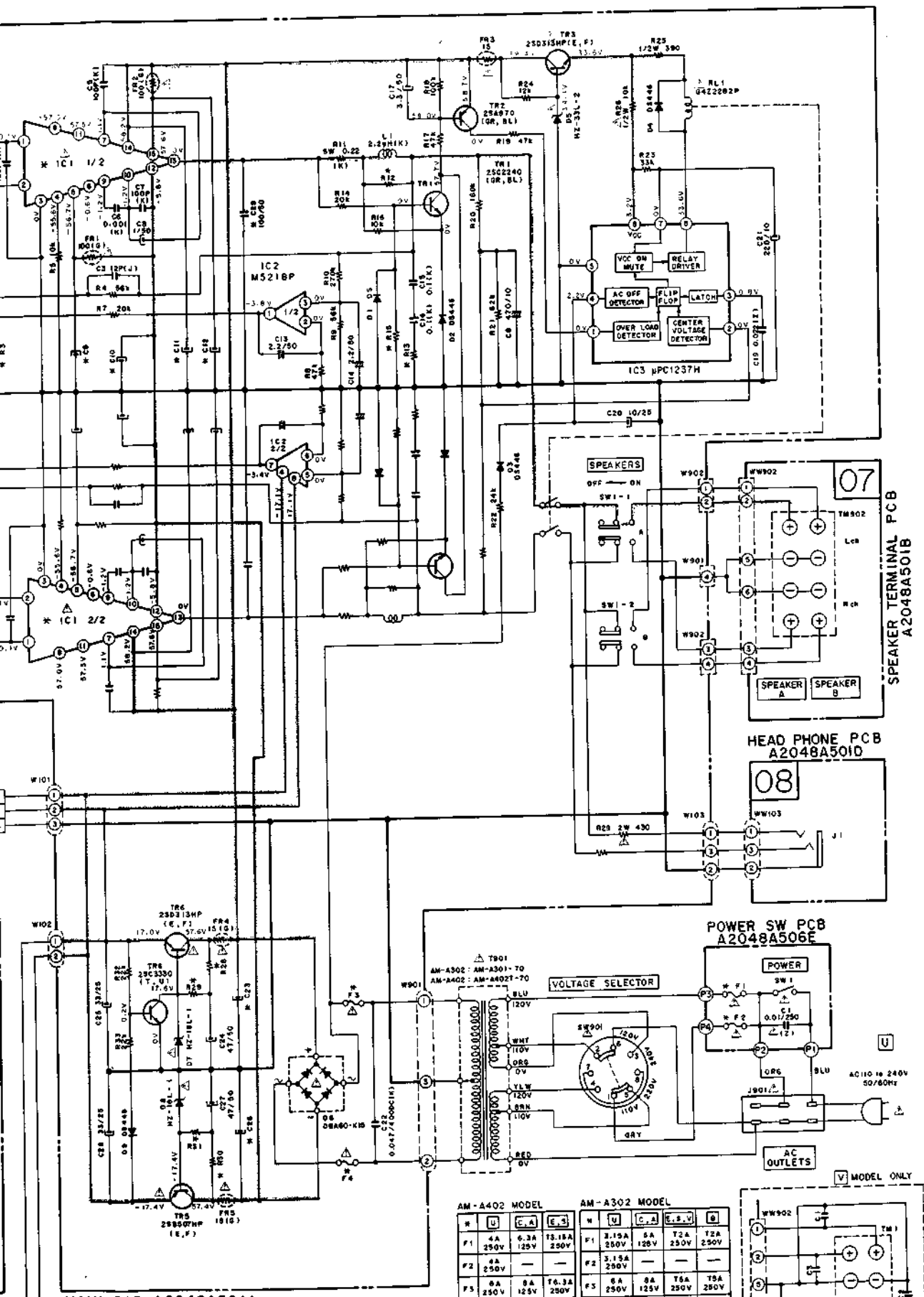

MAIN PCB A2048A501A

POWER SW PCB A2048A506E

(POWER SUPPLY) LINE

AM-A402 MODEL					AM-A302 MODEL				
R	U	C.A	C.S.V	B	R	U	C.A	C.S.V	B
F1	4A	6.3A	13.18A	250V	F1	3.15A	5A	T2A	T2A
	250V	125V	250V			250V	128V	250V	250V
F2	8A				F2	3.15A			
	250V					250V			
F3	8A	8A	T6.3A	T5A	F3	6A	8A	T6A	T5A
	250V	125V	250V	250V		250V	125V	250V	250V
F4	8A	8A	T6.3A	T5A	F4	6A	6A	T5A	T5A
	250V	125V	250V	250V		250V	125V	250V	250V

R	AM-A302	AM-A402
C10, C11	10/63	10/100
C9, C12	100/63	100/90
C4, C29	V ONLY	100P

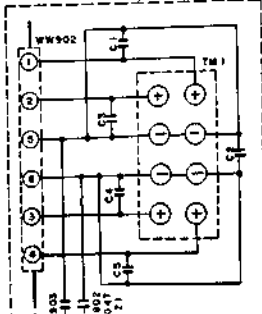

109

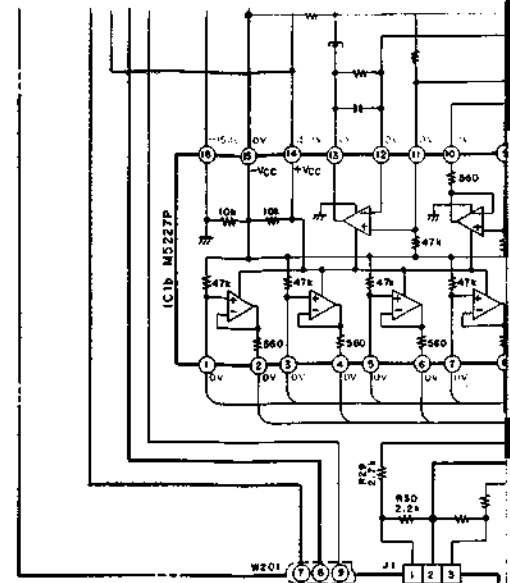
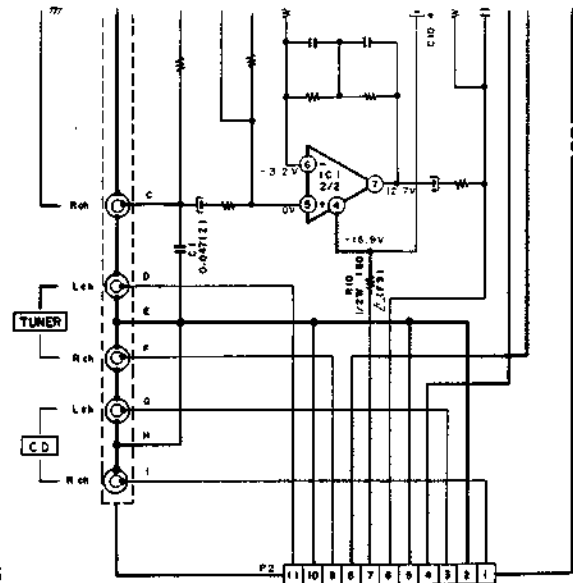
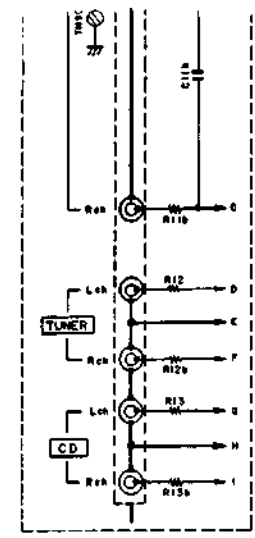

For Service Manuals Contact  
**MAURITRON TECHNICAL SERVICES**  
 8 Cherry Tree Rd, Chinnor  
 Oxon OX9 4QY  
 Tel: 01844-351694 Fax: 01844-352554  
 Email: enquiries@mauritron.co.uk

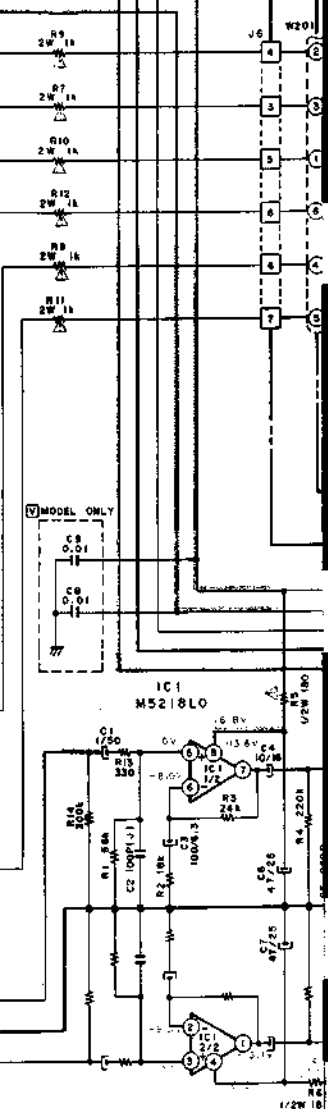
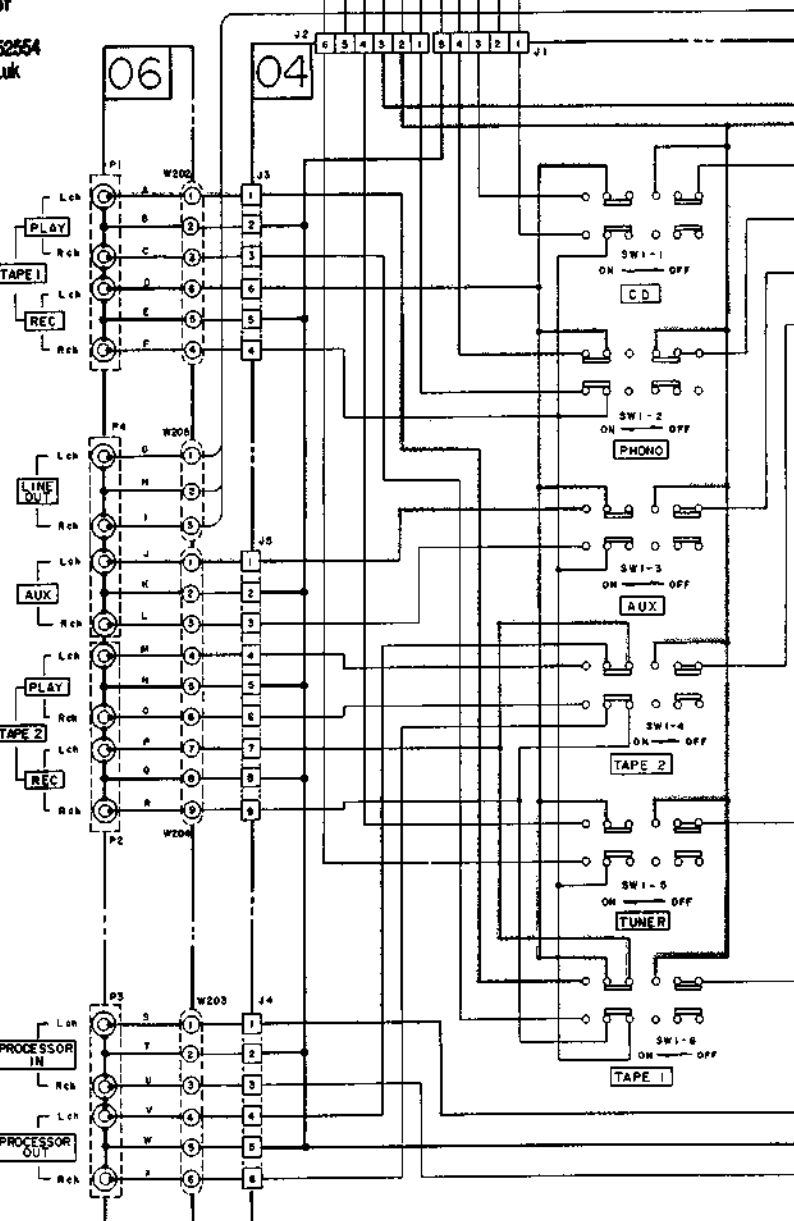
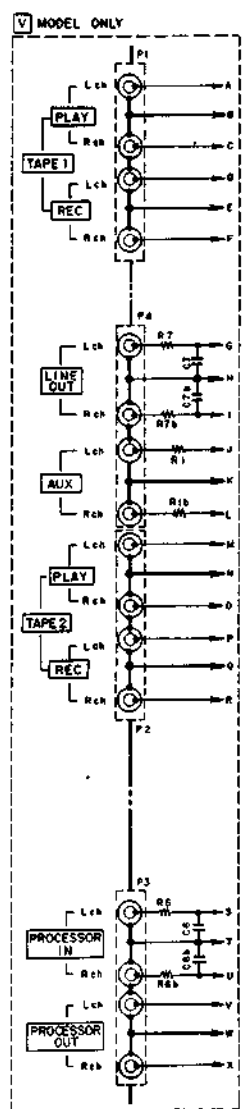

PIN JACK  
 PCB  
 A2048A506D

FUNCTION PCB A2048A506B

001876

For Service Manuals Contact  
**MAURITRON TECHNICAL SERVICES**  
 8 Cherry Tree Rd, Chinnor  
 Oxon OX9 4QY  
 Tel: 01844 351694 Fax: 01844 352551  
 Email: enquiries@mauritron.co.uk

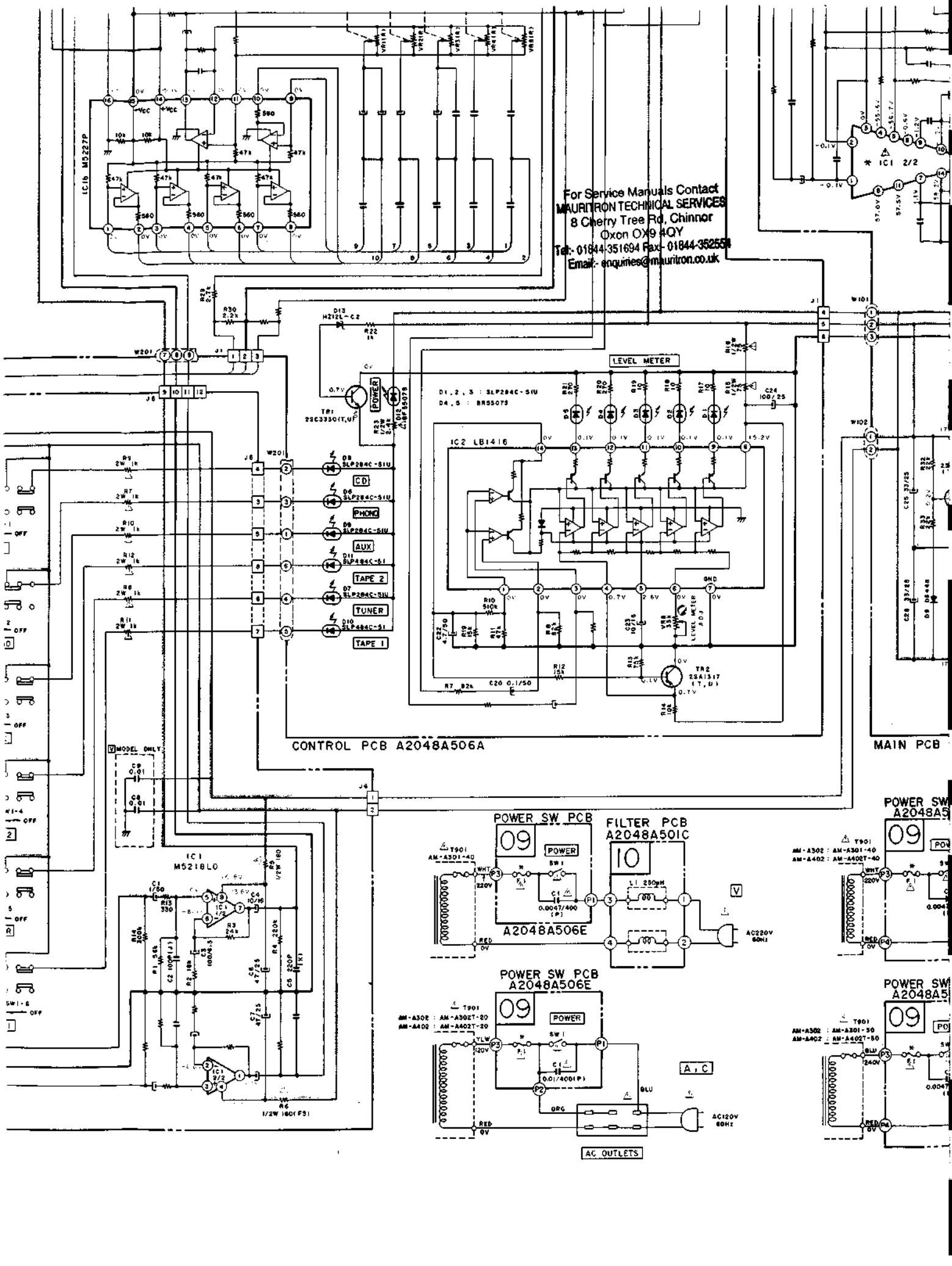

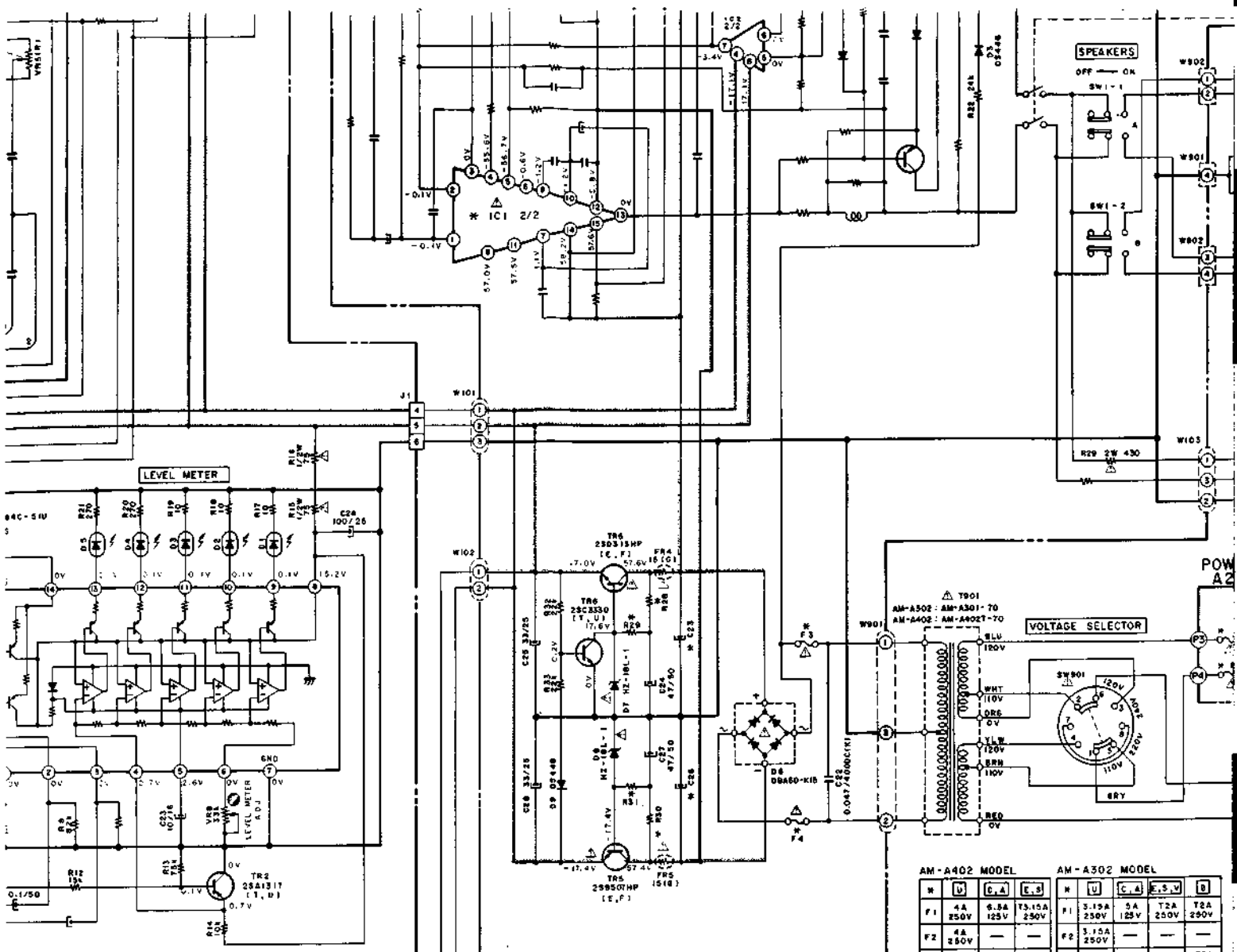

MAIN PCB A2048A501A

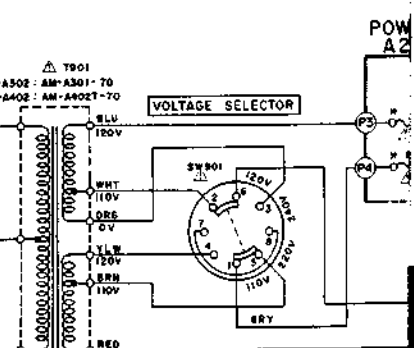
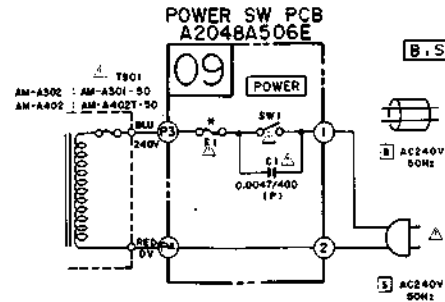
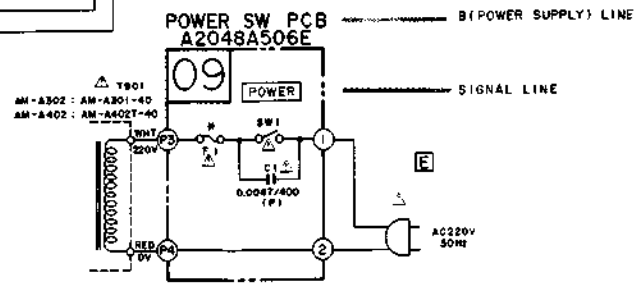
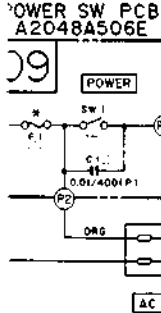
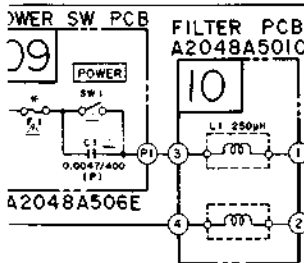

AM-A402 MODEL				AM-A302 MODEL			
R	U	E.A	E.S.V	R	U	E.A	E.S.V
F1	4A 250V	6.3A 125V	T3.15A 250V	F1	3.15A 250V	5A 125V	T2A 250V
F2	4A 250V	—	—	F2	3.15A 250V	—	—
F3	8A 250V	8A 125V	T6.3A 250V	F3	8A 250V	8A 125V	T5A 250V
F4	8A 250V	8A 125V	T6.3A 250V	F4	8A 250V	8A 125V	T5A 250V

R	AM-A302	AM-A402
C10, C11	10/63	10/100
C8, C12	100/63	100/60
C4, C28	100P ONLY	100P
C28, C28	8000/55	8000/7.1
R8	$\begin{matrix} U \\ D \\ E \\ A \end{matrix}$ 750 800	820
R12, R13	1W 10	2W 10
R18	750K	820K
R28, R30	6.2K	6.2K
R29, R31	2.7K	3K
IC1	$\begin{matrix} U \\ D \\ E \\ A \end{matrix}$ STK4038-2 $\begin{matrix} U \\ D \\ E \\ A \end{matrix}$ STK4042-2	STK4044-2

WARNING:  $\Delta$  INDICATES SAFETY CRITICAL COMPONENTS. FOR CONTINUED SAFETY, REPLACE SAFETY CRITICAL COMPONENTS ONLY WITH MANUFACTURER'S RECOMMENDED PARTS.  
 AVERTISSEMENT:  $\Delta$  IL INDIQUE LES COMPOSANTS CRITIQUES DE SECURITE POUR MAINTENIR LE DEGRÉ DE SECURITE DE L'APPAREIL. NE REMPLACER QUE DES PIÈCES RECOMMANDÉES PAR LE FABRICANT.

INDICATED VOLTAGES ARE MEASURED AT CD AND NO INPUT

AM-A302 SCHEMATIC NO



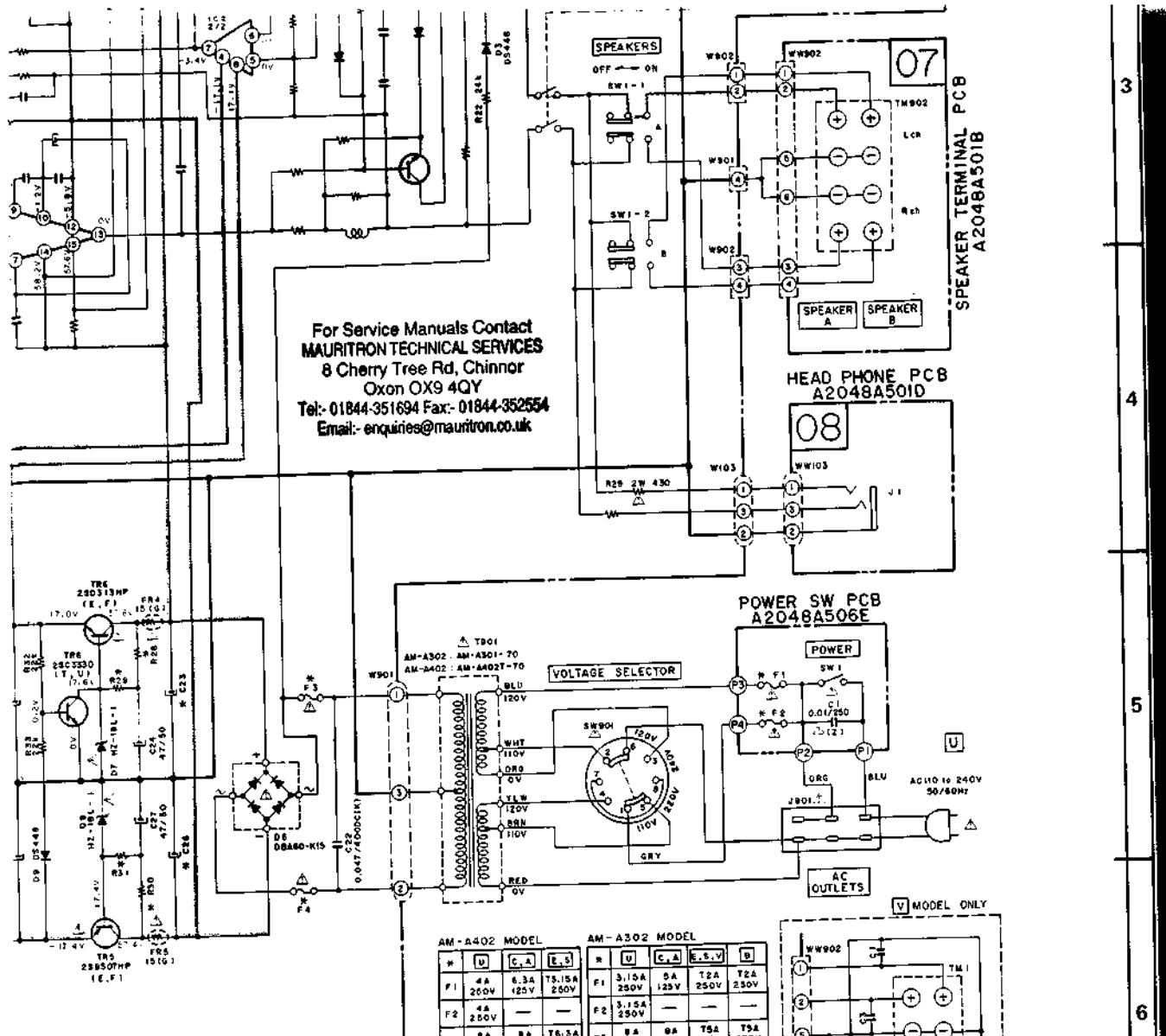

For Service Manuals Contact  
**MAURITRON TECHNICAL SERVICES**  
 8 Cherry Tree Rd, Chinnor  
 Oxon OX9 4QY  
 Tel: 01844-351694 Fax: 01844-352554  
 Email: enquiries@mauritron.co.uk

PCB A2048A501A

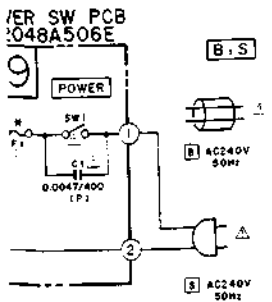
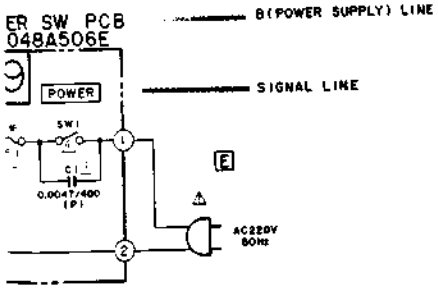

AM-A402 MODEL					AM-A302 MODEL							
F	U	C.A	E.S	B	F	U	C.A	E.S.V	B			
F1	4A	250V	6.3A	75.15A	250V	3.15A	5A	125V	T2A	T2A	250V	250V
F2	4A	250V	—	—	F2	3.15A	—	—	—	—	—	—
F3	8A	250V	8A	76.3A	250V	8A	8A	125V	T5A	T5A	250V	250V
F4	8A	250V	8A	125V	250V	6A	8A	125V	T5A	T5A	250V	250V

* C	AM-A302	AM-A402
C10, C11	10/63	10/100
C9, C12	100/63	100/60
C4, C29	ONLY 100P	—
C23, C26	6800/56	6800/71
R3	750 680	620
R12, R15	1W 10	2W 10
R16	750k	620k
R28, R30	6.2k	6.2k
R29, R31	2.7k	3k
IC1	STK4038-2 STK4042-2	STK4044-2

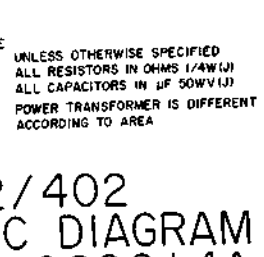
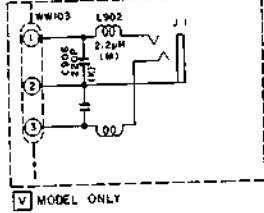
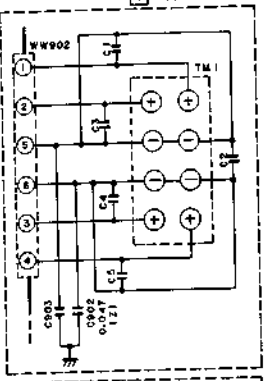

WARNING INDICATES SAFETY CRITICAL COMPONENTS FOR CONTINUED SAFETY. REPLACE SAFETY CRITICAL COMPONENTS ONLY WITH MANUFACTURER'S RECOMMENDED PARTS.  
 AVERTISSEMENT INDIQUE LES COMPOSANTS CRITIQUES DE SECURITE POUR MAINTENIR LE DEGRE DE SECURITE DE L'APPAREIL. NE REMPLACER QUE DES PIECES RECOMMANDEES PAR LE FABRICANT

NOTE  
 UNLESS OTHERWISE SPECIFIED  
 ALL RESISTORS IN OHMS (1/4W/1/2)  
 ALL CAPACITORS IN UF 50WV(1/2)  
 POWER TRANSFORMER IS DIFFERENT  
 ACCORDING TO AREA

INDICATED VOLTAGES ARE MEASURED  
 AT CD AND NO INPUT.

# AM-A302/402 SCHEMATIC DIAGRAM No. 860614A

3  
4  
5  
6  
7  
8

H

I

J

K

For Service Manuals Contact  
**MAURITRON TECHNICAL SERVICES**  
 8 Cherry Tree Rd, Chinnor  
 Oxon OX9 4QY  
 Tel: 01844-351894 Fax: 01844-352554  
 Email: enquiries@mauritron.co.uk

- TR1 ..... 25C2240
- TR2 ..... 25A970
- TR3, TR4 ..... 25D313MP
- TR5 ..... 25B407 MP
- TR6 ..... 25C3390
- TR7 ..... PNP TRANSISTOR
- TR8 ..... NPN TRANSISTOR

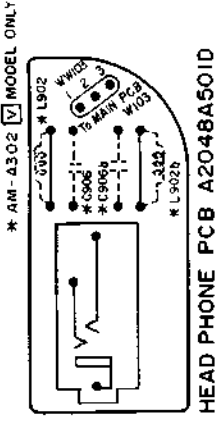
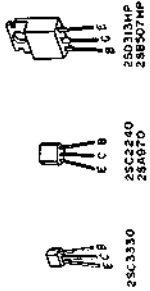

\* IC1  
 AM - 4302 [U][D][B] MODEL  
 AM - 4402 [U][D][B] MODEL

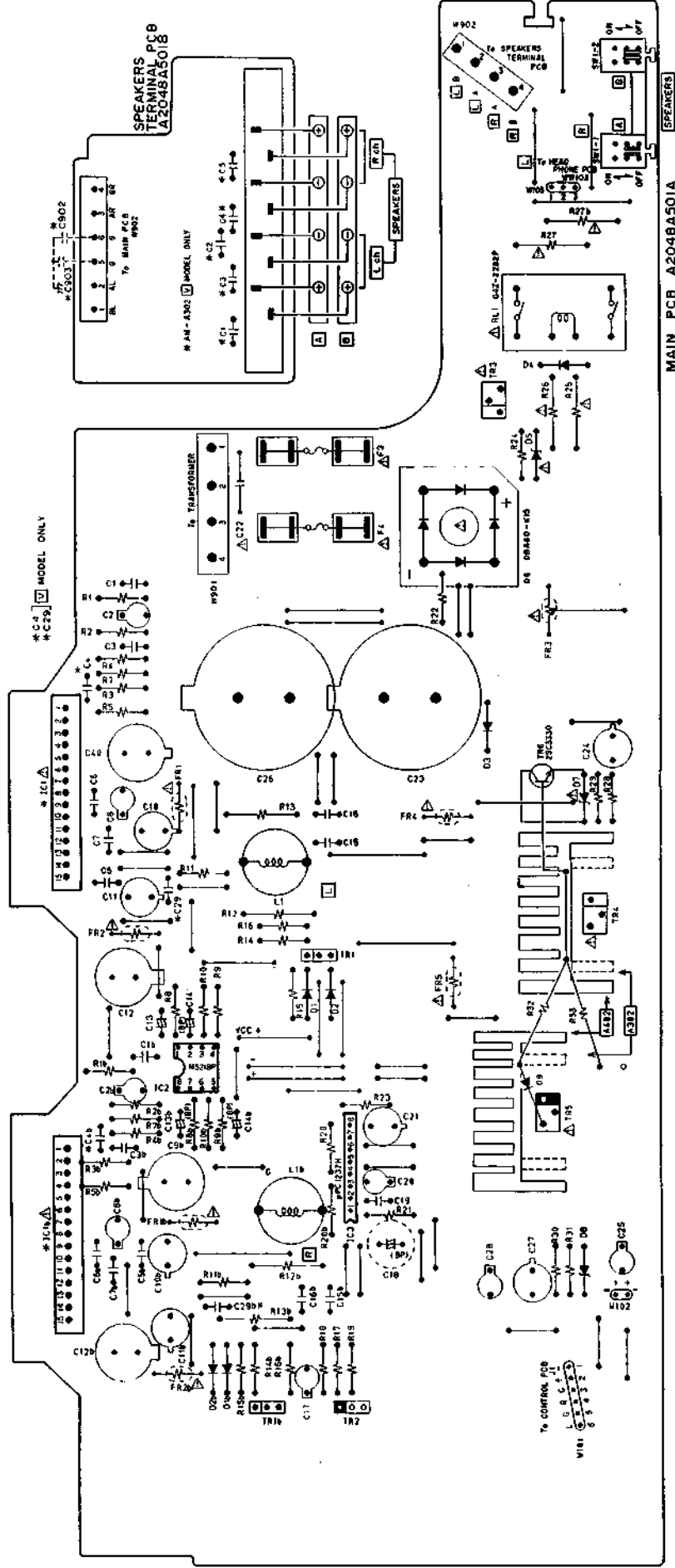

WARNING: Δ INDICATES SAFETY CRITICAL COMPONENTS FOR CONTINUED SAFETY.  
 REPLACE SAFETY CRITICAL COMPONENTS ONLY WITH MANUFACTURER'S  
 RECOMMENDED PARTS  
 AVERTISSEMENT: Δ IL INDIQUE LES COMPOSANTS CRITIQUES DE SÉCURITÉ.  
 POUR MAINTENIR LE DEGRÉ DE SÉCURITÉ DE L'APPAREIL,  
 NE REMPLACER QUE DES PIÈCES RECOMMANDÉES PAR LE FABRICANT

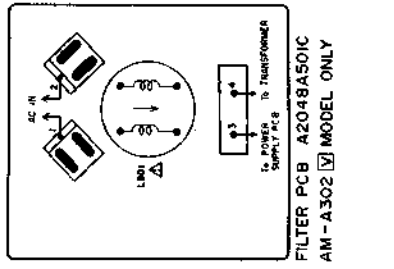
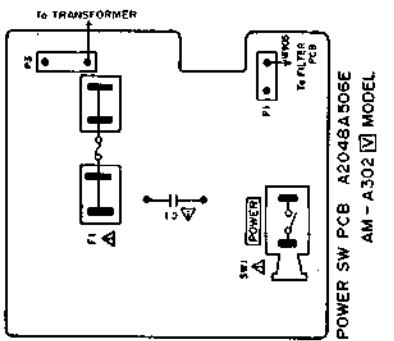
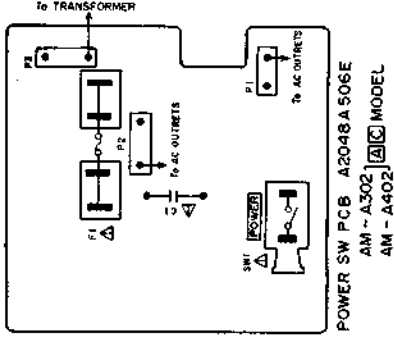
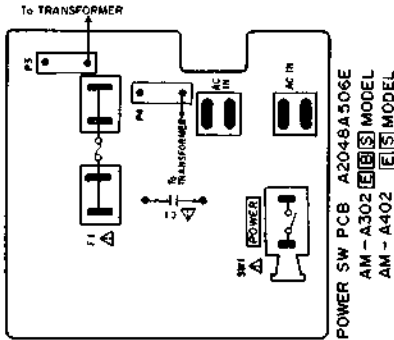
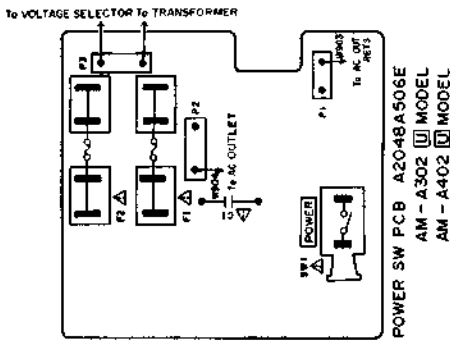

For Service Manuals Contact  
**MAURITRON TECHNICAL SERVICES**  
8 Cherry Tree Rd, Chinnor  
Oxon OX9 4QY  
Tel: 01844-351694 Fax: 01844-352554  
Email: enquiries@mauritron.co.uk

WARNING: Δ INDICATES SAFETY CRITICAL COMPONENTS FOR CONTINUED SAFETY.  
REPLACE SAFETY CRITICAL COMPONENTS ONLY WITH MANUFACTURER'S  
RECOMMENDED PARTS

AVERTISSEMENT: Δ IL INDIQUE LES COMPOSANTS CRITIQUES DE SÉCURITÉ.  
POUR MAINTENIR LE DEGRÉ DE SÉCURITÉ DE L'APPAREIL,  
NE REMPLACER QUE DES PIÈCES RECOMMANDÉES PAR LE FABRICANT

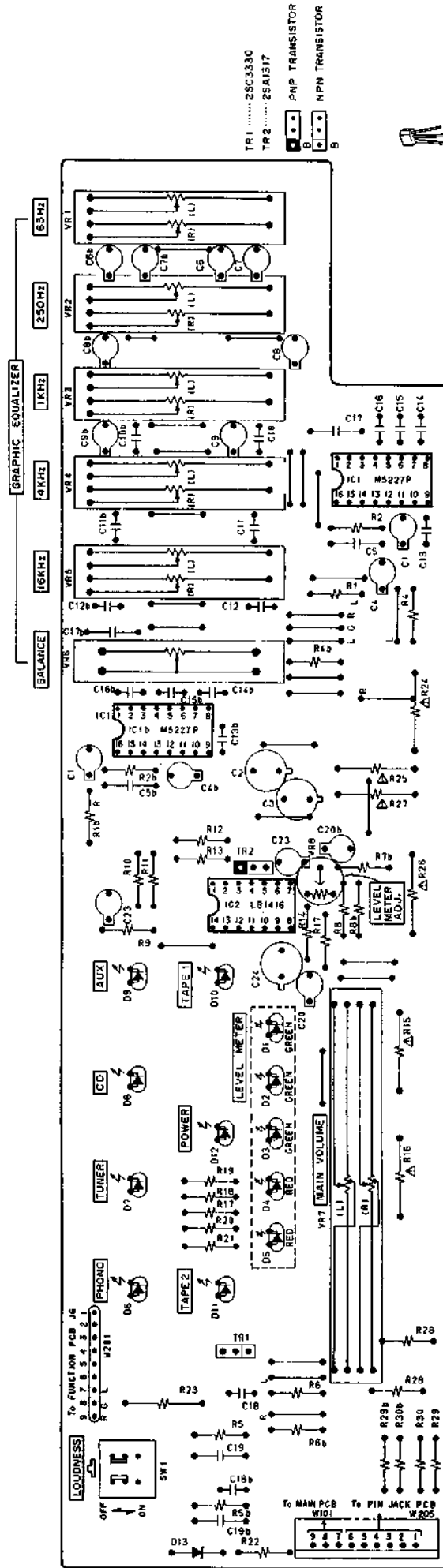

For Service Manuals Contact  
**MAURITRON TECHNICAL SERVICES**  
 8 Cherry Tree Rd, Chinnor  
 Oxon OX9 4QY  
 Tel: 01844-351634 Fax: 01844-352564  
 Email: enquiries@mauritron.co.uk

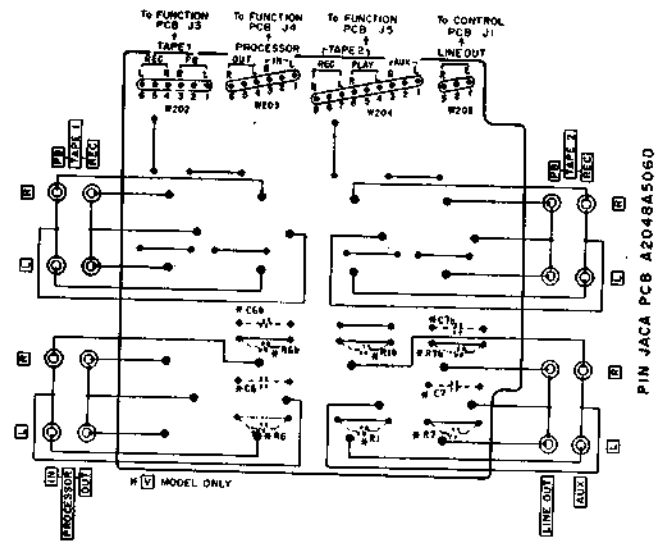
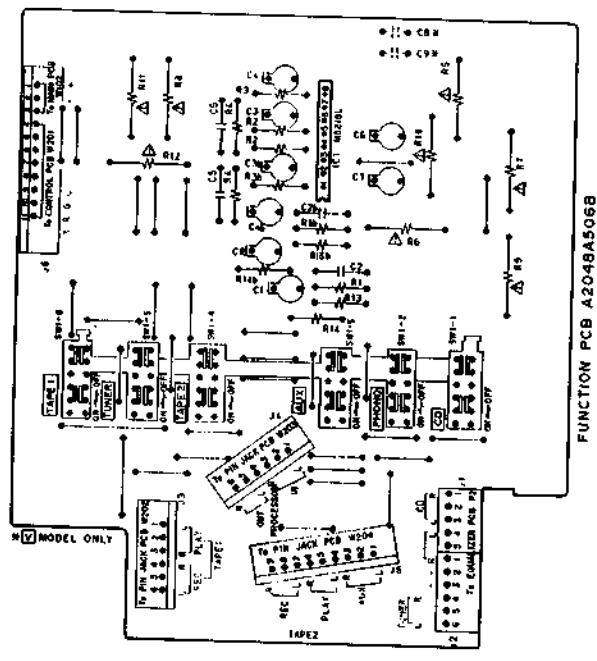
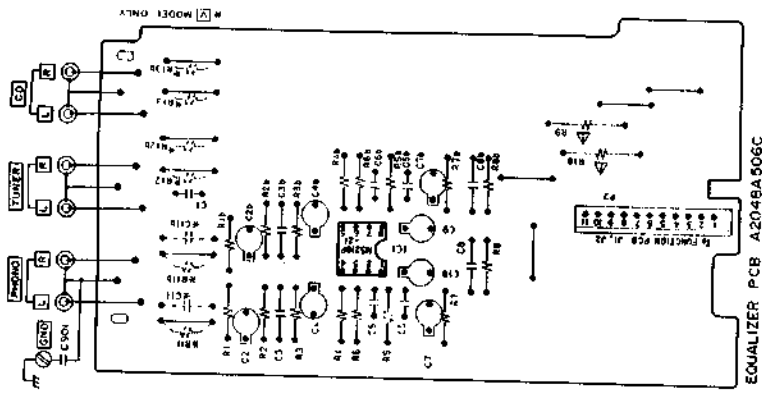

WARNING:  $\Delta$  INDICATES SAFETY CRITICAL COMPONENTS FOR CONTINUED SAFETY.  
 REPLACE SAFETY CRITICAL COMPONENTS ONLY WITH MANUFACTURER'S  
 RECOMMENDED PARTS  
 AVERTISSEMENT:  $\Delta$  IL INDIQUE LES COMPOSANTS CRITIQUES DE SÉCURITÉ.  
 POUR MAINTENIR LE DEGRÉ DE SÉCURITÉ DE L'APPAREIL,  
 NE REMPLACER QUE DES PIÈCES RECOMMANDÉES PAR LE FABRICANT

MODEL AM-A302  
 STK4038-2  
 STK4042-2

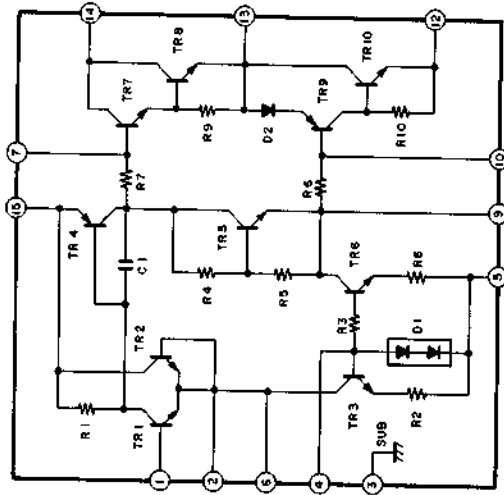

MODEL AM-A102  
 STK4141-2

MODEL AM-A202  
 STK4171-2  
 STK4152-2

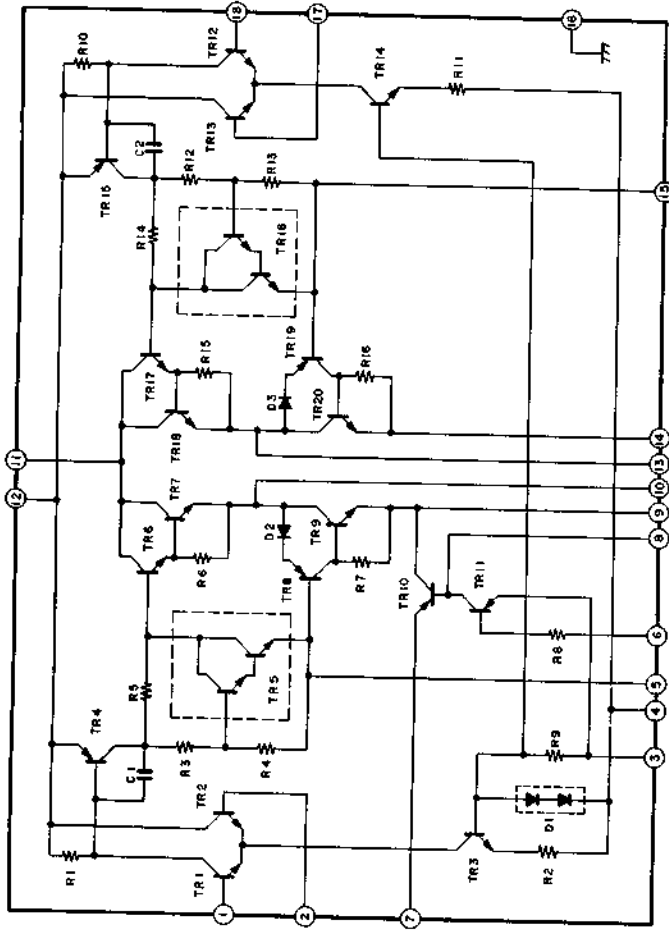

For Service Manuals Contact  
**MAURITRON TECHNICAL SERVICES**  
 8 Cherry Tree Rd, Chinnor  
 Oxon OX9 4QY  
 Tel: 01844-351694 Fax: 01844-352554  
 Email: enquiries@mauritron.co.uk