

SERVICE MANUAL
STEREO CASSETTE DECK
MODEL DT-35

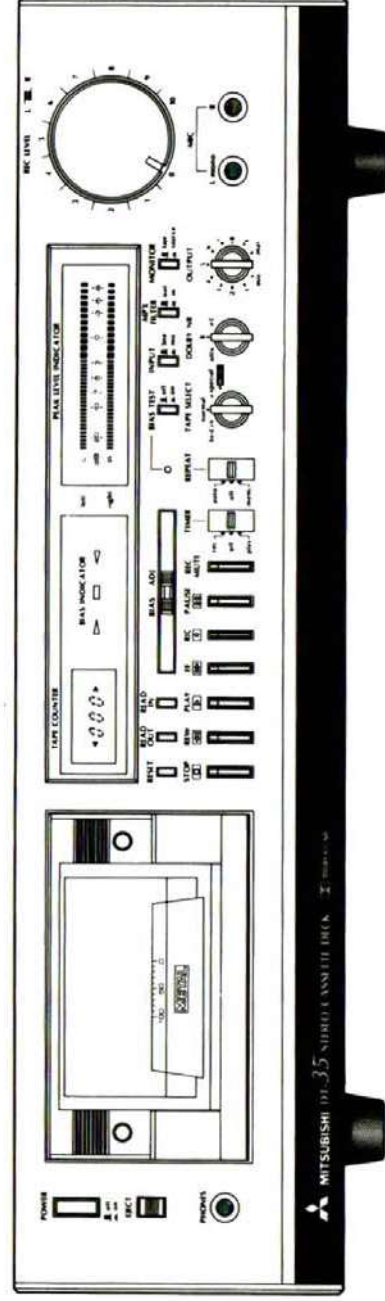

CONTENTS

SPECIFICATIONS 2

FRONT PANEL TERMINOLOGY AND FUNCTIONS 3

DISASSEMBLY INSTRUCTIONS 5

MECHANICAL ADJUSTMENTS 8

ELECTRICAL ADJUSTMENTS 9

BLOCK DIAGRAM 13

INTERNAL DIAGRAMS AND PIN OUT OF INTEGRATED CIRCUITS 14

WIRING DIAGRAM 21

SCHEMATIC DIAGRAM 23

PRINTED CIRCUIT BOARDS 27

EXPLODED VIEW OF CABINET 31

EXPLODED VIEW OF MECHANISM 32

PARTS LIST (MECHANICAL AND CABINET) 34

PARTS LIST 36

PACKING INSTRUCTIONS 39

SPECIFICATIONS

Type	4 track, 2 channel Stereo Cassette Deck.
Tape speed	4.75 cm/s (1-7/8 ips)
Tape speed accuracy	± 1%
Motor type	
Capstan motor	DC servo motor
Reel motor	DC motor
Head material	
REC/PB head	M&X Hard permalloy (Combination type)
Erase head	Sendust & Ferrite
Wow and flutter (Playback)	0.04% Wrms
Fast forward/rewind times	85 sec. (C-60) type
SN ratio	
(400 Hz, 3% THD, Weighted, Metal tape)	
Dolby NR off	58 dB
Dolby B-type NR	66 dB
Dolby C-type NR	74 dB
Frequency response	
(±3dB, record level 160 pwb/mm-20dB)	
Normal tape	30 — 16,000 Hz
Special tape	.30 — 18,000 Hz
Metal tape	30 — 19,000 Hz
Fe-Cr tape	30 — 18,000Hz
Erasure ratio (1kHz)	65 dB
Crosstalk (1 kHz)	
Between channels	35 dB
Between tracks	65 dB
Harmonic distortion	
(400 Hz 160 pwb/mm)	1% (special tape)
Sensitivity/impedance	
Mic input	0.3 mV (2.2 k ohms)
Line input	70 mV (47 k ohms)
Output level	
Line output	700 mV (22 k ohms Load)
Headphones	2 mW (8 ohms Load)
Bias frequency	105 kHz
Power consumption	30 W
Dimensions (W x H x D)	470 x 135 x 296 mm (18-1/2 x 5-3/8 x 11-5/8")
Weight	7.6 kg (16.8 lbs)

Noise Reduction System manufactured under license from Dolby Laboratories Licensing Corporation.

'Dolby' and the double-D symbol are trademarks of Dolby Laboratories Licensing Corporation. Specifications of this unit are subject to change without notice for improvement.

FRONT PANEL TERMINOLOGY AND FUNCTIONS

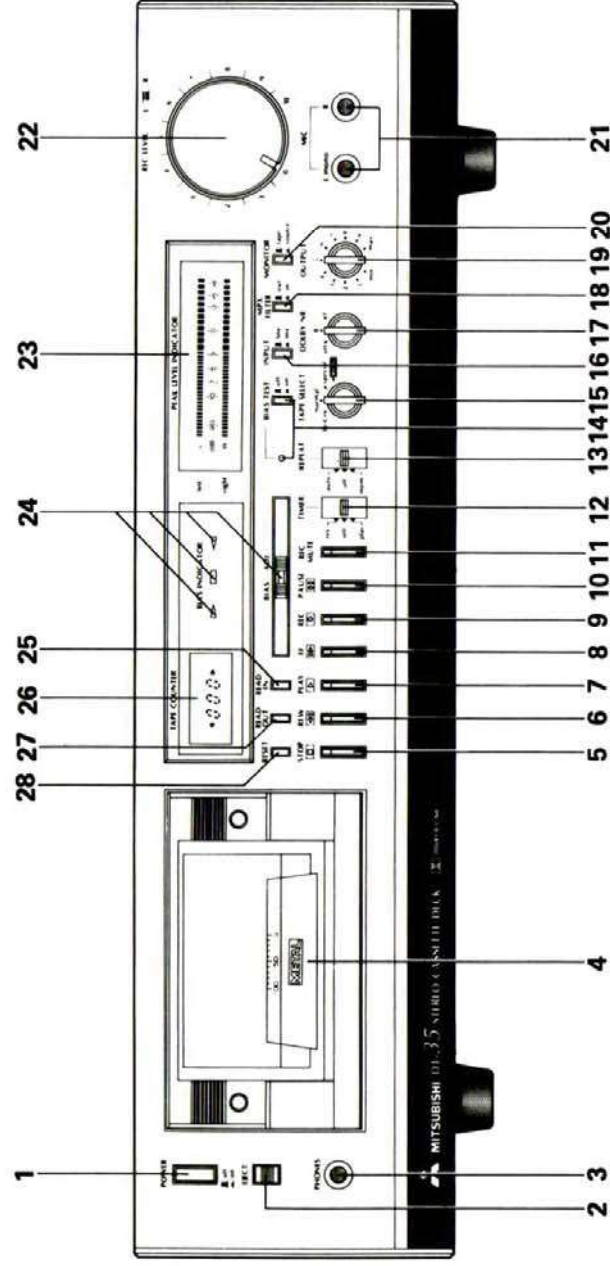

1. POWER (Power switch)

2. EJECT (Eject button)

Press this button for opening the cassette holder.

3. PHONES (Headphone jack)

Be sure to use headphones with an impedance of 8 ~ 500 ohms.

4. CASSETTE HOLDER

Insert the cassette in this holder directing the side (A or B) you want to hear toward you with the tape side downward.

5. STOP (■, Stop button)

Press this button to stop the tape.

6. REW (◀◀, Rewinding button)

By pressing this button, the tape rewinds at high speed.

7. PLAY (▶, Playback button)

Press this button for playback or recording. (See Item 9)

8. FF (▶▶, Fast forward winding button)

By pressing this button, the tape advances at high speed.

9. REC (●, Recording button)

For recording, press the PLAY button while pressing this button. If a cassette is not loaded or either tab at the rear of the cassette is removed, the failsafe recording mechanism operates and recording will not proceed.

10. PAUSE (||, Pause button)

Press this button to temporarily stop the tape during recording or playback. By pressing the PLAY button, the pause mechanism is released and recording or playback will resume.

11. REC MUTE (Recording muting button)

By keeping this button pressed during recording, it is possible to produce a non-recorded portion of the tape as it causes recording signals to be cut off.

12. TIMER (Timer switch)

Using a commercial timer, you can automatically record or playback at a pre-set time.

13. REPEAT (Automatic repeat and memory repeat switch)

At the "auto" position of this switch, when the tape comes to the end in recording or playback, the tape will rewind automatically to the beginning and playback will start. At the "mem" position, if you set the tape counter to "000" by pushing the RESET button at the start of recording or playback, when you rewind the tape after recording or playback, the tape will stop at the position "000" on the tape counter and automatically restart playback.

14. BIAS TEST (Test signal switch and indicator)

If you press this switch to the "on" position during recording the built-in oscillator will be activated, the test signal will be recorded on the tape and the bias indicator will be illuminated.

15. TAPE SELECT

This switch selects the optimum bias current in recording and the equalizer characteristics in recording and playback according to the tape being used.

16. INPUT (Input Selector Switch)

This switch is for selecting MIC inputs on the front

17. DOLBY NR (Dolby noise reduction switch)

Set this switch to the DOLBY NR "B" position for recording with Dolby B-type NR. When the recording is made with Dolby NR "B", be sure to set this switch to the "B" position during playback. Set this switch to the DOLBY NR "C" position for recording with Dolby C-type NR. When the recording is made with Dolby NR "C", be sure to set this switch to the "C" position during playback. Similarly, when you record with this set to the "off" position, play the tape with the same switch setting. Dolby noise reduction system can reduce the tape hiss noise in recording and playback.

18. MPX FILTER (FM multiplex filter switch)

Set this switch to the "in" position for recording from FM stereo broadcasting with the Dolby noise reduction system.

19. OUTPUT (Output level control)

This control is for adjusting the levels of the output signals through the OUTPUT terminals on the rear panel and also through the PHONES jack.

20. MONITOR (Monitor switch)

In the "tape" position of this switch, the recorded signals on the tape can be monitored. In the "source" position, the input signals can be monitored.

21. MIC (Microphone inputs)

Live recording with two microphones can be made via these front panel microphone inputs. For monaural recordings on both the right (R) and left (L) channels, insert the microphone plug into the left (L) channel only.

22. REC LEVEL (Recording level controls)

These controls are for adjusting the levels of the recording signals through the INPUT terminals on the rear panel and MIC inputs on the front panel.

23. PEAK LEVEL INDICATOR

These indicators show the peak levels of the input signals when recording as well as the reproduced signals during playback. The indication will be held at highest input level when the peak level exceeds -1 dB. The highest level will continue to be displayed for approx. 2 second, thereafter normal indication will resume. If a still higher peak is reached while a former peak is being held, the new higher peak will be indicated. As long as the peak level is less than -1 dB, the indication will not be held.

24. BIAS ADJ (Bias current adjusting knob and indicators)

Sliding this control adjusts the bias current to the recording head. If the right indicator is illuminated, slide to the left until only the center indicator is illuminated. If the left indicator is illuminated, slide to the right until only the center indicator is illuminated. The left (or right) indicator is illuminated when the high frequency range of the recorded signals is strong (or weak). The center indicator is illuminated when the high frequency range of the recorded signals is correct.

25. READ IN (Read in button)

Set the REPEAT switch to the "mem," position and press this button at the end of some musical source for the short repeat function. When pressing this button, the indexing figures of the tape counter will be memorized. When the tape reaches the memorized indexing figures in playback, the tape will automatically rewind.

26. TAPE COUNTER

At the start of recording, push the reset button to set the tape counter to "000". If you list the recorded programs and the indexing figures of the tape counter you can easily "cue" a program for playback.

27. READ OUT (Read out button)

When you want to check the memorized indexing figures of the tape counter, press this button.

28. RESET (Reset button)

By pressing this button, the tape counter will be set to "000".

DISASSEMBLY INSTRUCTIONS

PRECAUTIONS

- 1) Refer to the exploded views for disassembly of the DT-35.
- 2) Do not allow any lubricant to be deposited on the motor pulley, idler wheels, flywheel, pinch rollers, capstan belt, or reel rests. If lubricants does become deposited on any of these surfaces, thoroughly clean with alcohol.
- 3) After disassembling any mechanical parts, avoid allowing any dust or dirt to be deposited on the lubricated parts.
- 4) During reassembly, use only the original screws to prevent damage to the unit.
- 5) Use caution when handling the front panel or meters during disassembly and reassembly.
- 6) Put all small parts such as screws and knobs in a container as they are removed.
- 7) Many of the screws on the mechanism are secured with screw lock paint. To loosen these screws, apply a drop or two of solvent/thinner. Allow 2 or 3 minutes and the screws may be removed.
- 8) For assembly, reverse the order of the disassembly procedures to assemble the set properly.

2. Removal of Bottom Cover

- 1) Remove the 8 screws shown in Fig. 2.
- * In this condition, the Main P.C. Board can be accessed for maintenance and repair purposes.

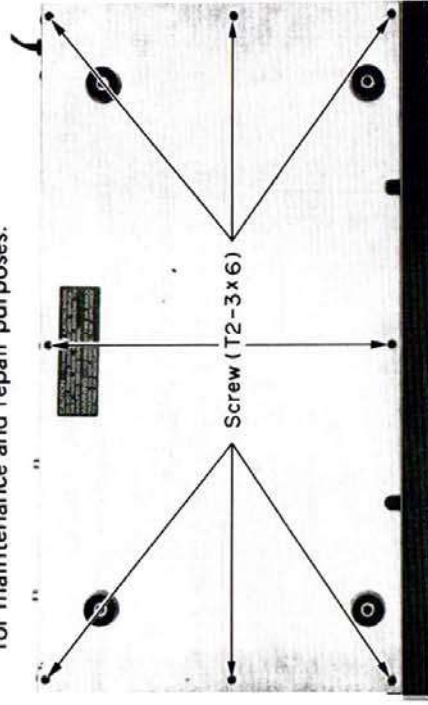

Fig. 2

3. Removal of Front Panel

- 1) Remove the top and bottom covers as described in procedures 1 and 2 above.
 - 2) Remove the cassette compartment door.
 - 3) Remove the knobs for the DOLBY NR and TAPE SELECT switches and OUTPUT and REC LEVEL.
 - 4) Remove 3 screws ① shown in Fig. 3.
 - 5) Remove 2 screws in Fig. 3.
 - 6) Remove the 2 screws ③ shown in Fig. 4.
- * In this condition, the Switch/Meter P.C. Board may be accessed for checking and parts replacement purposes.

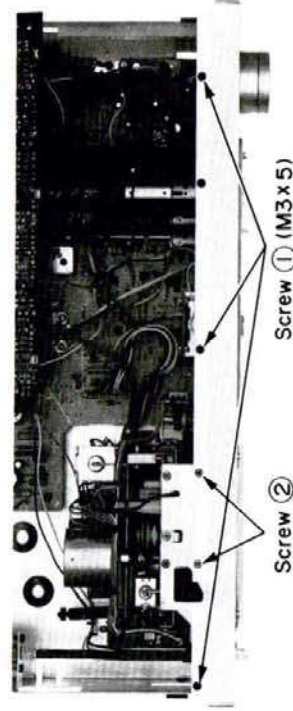

Fig. 3

Removal of Case

1. Removal of Top Cover
Remove the 4 screws shown in Fig. 1, and lift the top cover off.

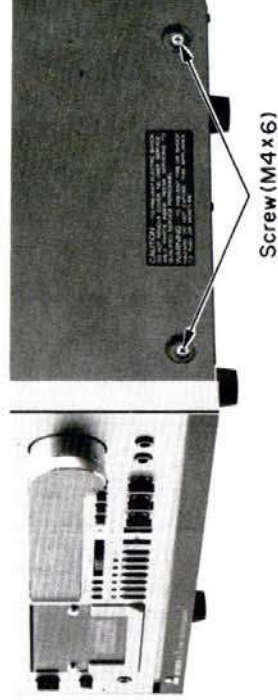

Fig. 1

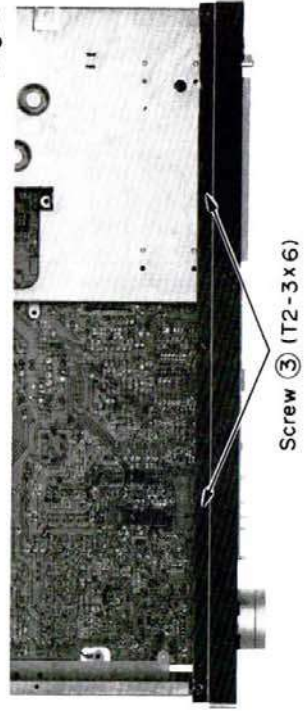

Fig. 4

Removal of Mechanism Section

1. Removal of Mechanism Assembly

- 1) Remove front panel as described in "Removal of Case" 1 through 3.
- 2) Remove the power switch button.
- 3) Remove connectors (J101, J305, J307) from the Main P.C. Board.
- 4) Take off the stoper and also the headphone jack shown in Fig. 5.
- 5) Remove the 6 screws shown in Fig. 5.
- 6) To remove the mechanism assembly, shift the mechanism backward by lifting its backside.

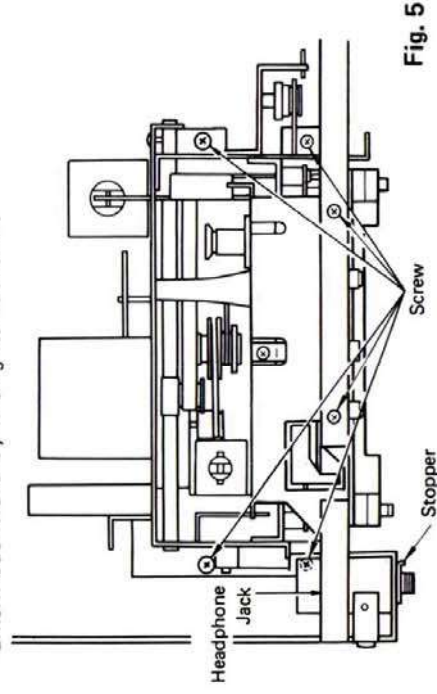

Fig. 5

2. Removal of Inter Connect P.C. Board

- 1) Remove the mechanism assembly as described in procedure 1 above. Remove screw ① shown in Fig. 6, and then remove the Inter Connect P.C. Board.
- 2) To remove the play solenoid, remove 2 screws ② shown in Fig. 6.
- 3) When mounting is required, refer to the "Mounting of Play Solenoid" on Page 8.

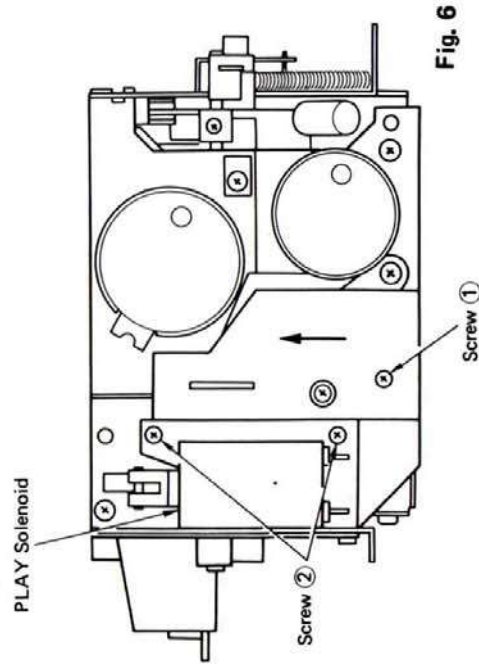

Fig. 6

3. Removal of Flywheel Holder and Flywheel

- 1) Remove the Inter connect P.C. Board and play solenoid as described in procedure 2 above, and then take off 2 springs at points A and B shown in Fig. 7.

- 2) To remove the flywheel, remove 2 screws ① shown in Fig. 7.
- 3) Take off the flywheel after disconnecting the main belt from the flywheel.

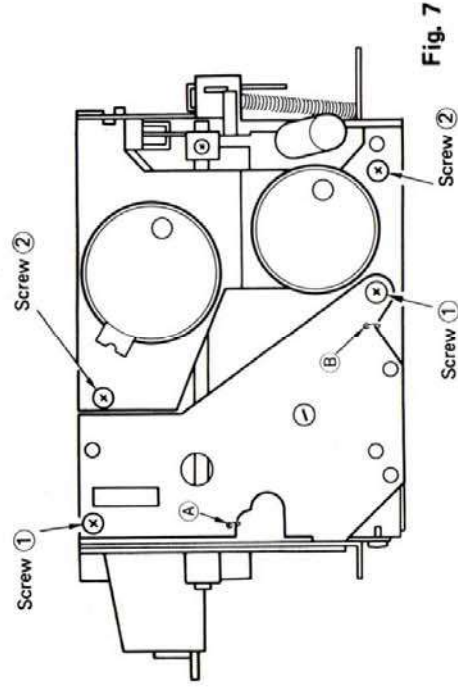

Fig. 7

4. Removal of Motor Holder

- 1) Remove the Inter Connect P.C. Board as described in Procedure 2 above, and then take off the capstan motor and reel motor belts.
 - 2) To remove the motor holder, remove the 2 screws ② shown in Fig. 7.
 - 3) In this condition, the FF/REW belt can be replaced.
 - 4) When taking off the belts of the capstan motor and reel motor, remove the 2 screws securing the motors.
- ### 5. Removal of Make-up Plate and Counter Belt
- 1) Remove the mechanism assembly as described in procedure 1 above. To remove the cassette spring, remove screw ① shown in Fig. 8.
 - 2) To remove the make-up plate, remove 2 screws ② shown in Fig. 8.
 - 3) In this condition, the counter belt can be replaced.

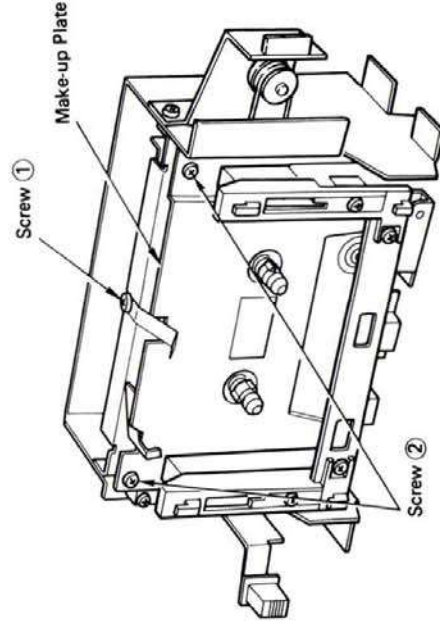

Fig. 8

6. Removal of Cassette Holder and FF/REW Solenoid

- 1) Following the procedures 1 through 5, remove the Inter-Connect P.C. Board, play solenoid, flywheel holder, motor holder, make-up plate and counter belt.
- 2) To remove the cassette holder lever, remove screw ① shown in Fig. 9.
- 3) To remove the plate (R) for maintenance of the mechanism base, remove 2 screws ② shown in Fig. 9.

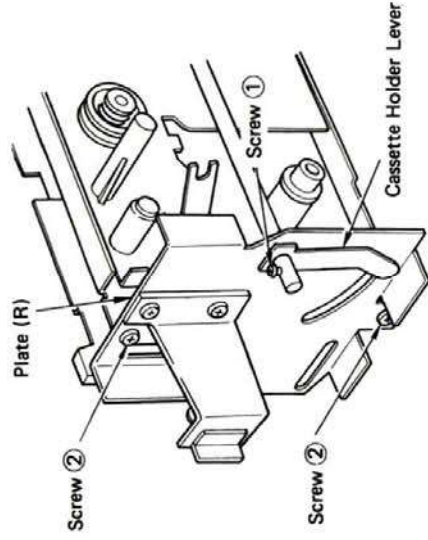

Fig. 9

- 4) Disconnect the spring from point A shown in Fig. 10.
- 5) To remove the cassette holder, remove the E-ring shown in Fig. 10.
- 6) Remove the 2 screws shown in Fig. 10 and turn the lever toward the arrow, then the plate (L) can be removed for maintenance on the mechanism base.

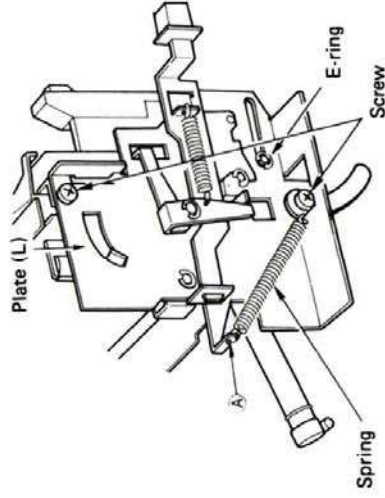

Fig. 10

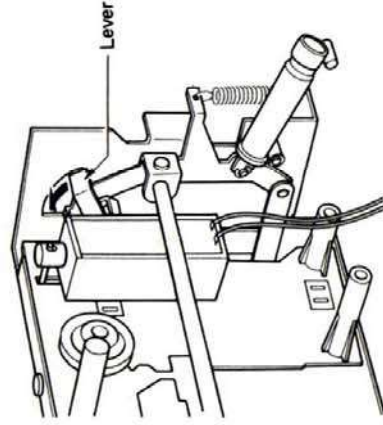

Fig. 11

- 7) To remove the FF/REW Solenoid, remove 2 screws shown in Fig. 12.

8) When mounting is required, refer to the "Mounting of Play Solenoid" on Page 8.

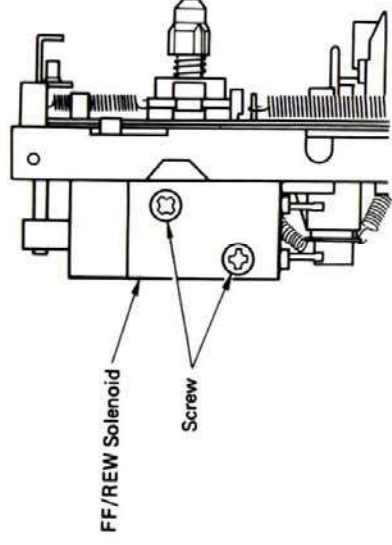

Fig. 12

MECHANICAL ADJUSTMENTS

1. Tape Speed Adjustment

- 1) Setting Connect a frequency counter to the output terminals.
- 2) Test tape MTT-111 (3kHz)
- 3) Adjustment Play the test tape, and use a small minushead screwdriver to adjust the capstan motor adjustment screw.
The frequency counter should read $3,000 \pm 10$ Hz.

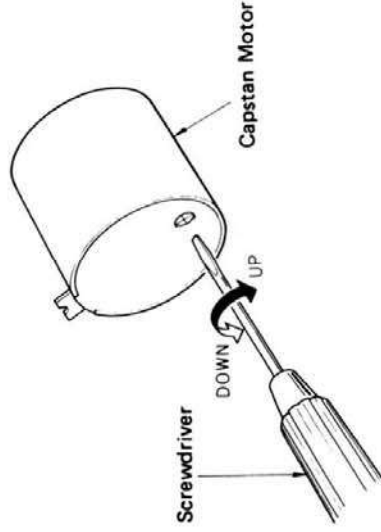

Fig. 13

2. Adjustment of Eraser Head

- 1) Install cassette tape (MC-10) with mirror attached, manipulate the solenoid used for head base absorption by hand and set conditions for playing.
- 2) Adjust the S screw so that tape can easily enter the eraser head tape guide and at the same time adjust so that the upper and lower intervals between tape and guide are of even dimension.

3. Adjustment of the Height of the Record/Play Head

- 1) Install cassette tape (MC-10) with mirror attached, manipulate the solenoid used for head base absorption by hand and set conditions for playing.
- 2) Set adjustment screws 1 ~ 3 for the Record/Play head so that the tape can easily enter the tape guide of the Record/Play head.
At the same time adjust so that the side of the head does not lean against the capstan and so that the upper and lower intervals between tape and tape guide are of even dimension.
- 3) Install test tape LCT-308M and set for play condition
 - a) Adjust screw No. 2 for maximum LR output.
 - b) Alternately adjust screw No. 1 and No. 3 for maximum mutual L and R output.
 - c) Adjust screw No. 2 for maximum mutual L and R output.
 - d) Confirm that side of head does not lean against capstan.
 - 4) Install test tape MTT-215C and set for play conditions.
 - a) Adjust screw No. 2 so that output of L and R at 10 Hz is at a maximum.
 - b) When the difference in output between L and R becomes greater than 1.5dB, readjustment from item (3) must be conducted.

- 5) Install the cassette tape with mirror attached in the input and set for play conditions.

- a) Confirm that there are no folds in the tape at the tape guide for the eraser head and for the Record/Play head. If there is a fold, make correction after adjusting the eraser head. Adjustment is completed when there are no folds apparent during running condition.

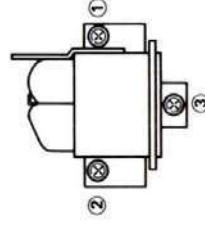

Fig. 14

4. FF/REW Solenoid (SOL-2) Mounting

- 1) After securing the solenoid temporarily, insert the plunger into the solenoid by hand and leave it in the pulled-in position.*
- 2) Then secure the solenoid tightly in a position which gives a gap of $0.8 \sim 1.2$ mm between the brake link and the $\phi 3.5$ boss of the intermediate pulley.

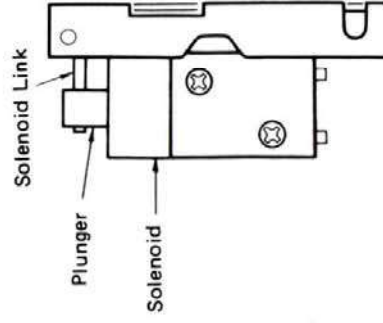

Fig. 15

* When inserting the plunger into the solenoid by hand, take care not to touch the solenoid link.

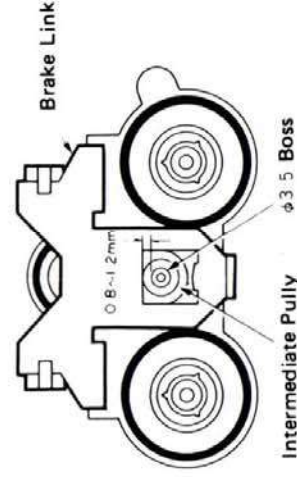

Fig. 16

5. PLAY Solenoid (SOL-1) Mounting

- 1) After securing the solenoid temporarily, insert the plunger into the solenoid by hand and leave it in the pulled-in position.*
- 2) After forcing the solenoid as far as it will go in the direction of the arrow in Fig. 17, secure the solenoid tightly, and check that the head base is in contact with the stopper (pinch roller shaft).

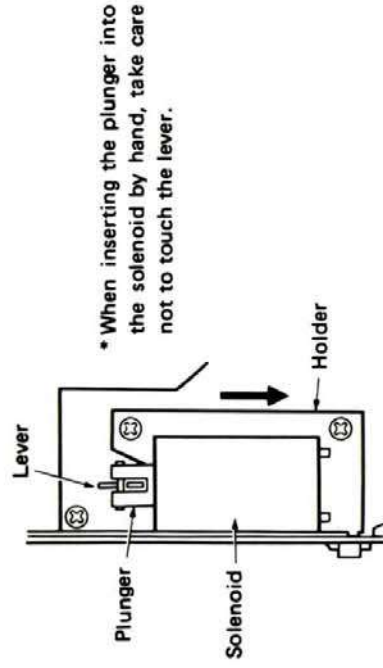

Fig. 17

6. Flywheel Thrust Play Adjustment

- 1) After mounting the holder in the mechanical section, adjust the flywheel thrust play to $0.1 \sim 0.3\text{mm}$ by the thrust play adjustment screw.

- 2) Since the pitch of this screw is 0.5mm , it will be displaced by 0.5mm in a single full turn. Refer to Fig. 18.

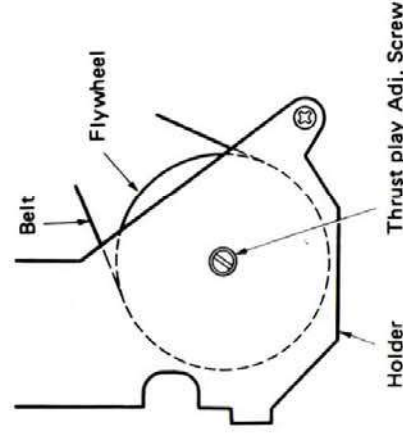

Fig. 18

ELECTRICAL ADJUSTMENTS

■ Measuring Equipment and Test Tapes

1. Audio generator : $20\text{Hz} \sim 20\text{kHz}$
2. Attenuator : $0 \sim 90\text{dB}$ in 0.1 or 0.5 steps
3. AC voltmeter (VTVM) : $20\text{Hz} \sim 200\text{kHz}$ (min.), input impedance $100\text{k}\Omega$ min. with measuring capacity below -60dB .
4. Frequency counter
5. Oscilloscope
6. Test tapes
 - MTT-111 (3kHz)
 - MTT-215C (10kHz/314Hz, -10dB , normal)
 - MTT-150 (400Hz Dolby level)
 - MCT-606SA (blank) High Bias Type

7. Measuring equipment connections

- * Unless otherwise specified, connect the measuring equipment to the tape deck as shown in Fig. 19.

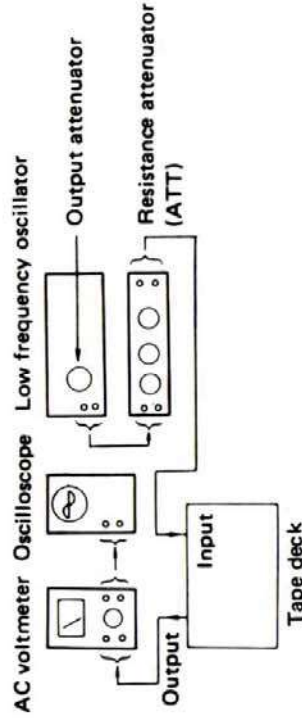

Fig. 19

- 1) Connect a $22\text{k}\Omega$ load resistor, an AC voltmeter, and an oscilloscope to the output terminals of the tape deck.
- 2) During recording adjustments, also connect an audio generator and an attenuator to the tape deck input terminals.

Playback Adjustments

1. Playback Output Level Adjustment

- 1) Test tape MTT-150 (Dolby level)
- 2) Adjusting point . . VR101 (L) and VR201 (R) semi-fixed resistors
- 3) Check point Negative side of Dolby P.C.B. TP2 (L) and Dolby P.C.B. TP2 (R)
- 4) Adjustment Play the test tape and adjust the semi-fixed resistors to obtain a reading of $775\text{mV} \pm 0.25\text{dB}$ on the negative side of Dolby P.C.B. TP2 and Dolby P.C.B. TP2

2. Meter Level Adjustment

- 1) Test tape MTT-150 (Dolby level)
- 2) Adjusting point . . VR102 (L) and VR202 (R) semi-fixed resistors
- 3) Adjustment Play the test tape and adjust the semi-fixed resistors so that the $0\text{dB} \pm 1\text{dB}$ dB segments light up.

Recording Adjustments

For adjustments 1 through 4, connect a 100Ω resistor between the head terminal and the white lead leading to the REC/PB head.

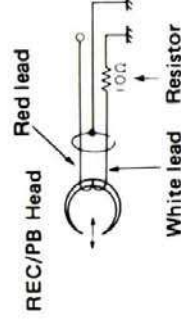

- * When recording, connect a 10Ω resistor between the minus (white) head lead and the head terminal.

Note: Connect the ground of the adjustment resistor to the P.C.B. ground line.

Fig. 20

1. Bias Frequency Adjustment

- 1) Setting Connect the frequency counter across both ends of the 10 Ω resistor.
- 2) Adjusting point . . Bias OSC-UNIT
- 3) Adjustment Adjust T501 until the frequency counter reads 105 kHz.

- * For the subsequent adjustments, switch the tape selector to the Special position.
- * Performing the presetting operations 2 through 4 prior to the adjustment procedures will make the respective adjustments easier.

2. Bias Current Presetting

- 1) Setting Connect the AC voltmeter across both ends of the 10 Ω resistor, and set the tape deck to "no-signal" recording mode.
- 2) Adjusting point . . Normal VR304 (L) and VR404 (R) semifixed.
Special VR305 (L) and VR405 (R) semifixed.
Metal VR306 (L) and VR406 (R) semifixed.
- 3) Adjustment Adjust each semifixed as follows.
Normal 7.5mV (750 μ A)
Special 9.0mV (900 μ A)
Metal 17.0mV(1,700 μ A)

3. Recording Current Presetting

- 1) Setting Set the deck to recording mode and apply a -10dB 400Hz input signal. After setting the front panel REC LEVEL controls to obtain a -7dB output at the output terminals.
Short the BIAS CUT terminals.
Connect the AC voltmeter across both ends of the 10 Ω resistor.
- 2) Adjusting point . . VR303(L) and VR403(R) semifixed resistors.
- 3) Tape selector pos . Special pos
- 4) Adjustment Adjust the semi-fixed resistors to obtain a reading of 1.0mV (100 μ A) on the AC voltmeter.

4. Peaking Presetting

- 1) Setting Set the deck to recording mode and apply a -10dB 400Hz input signal. Set the front panel REC LEVEL controls to obtain a -7dB output at the output terminals.

Short the BIAS CUT terminals, and drop the input level by 10 dB.

Connect the AC voltmeter across both ends of the 10 Ω resistor.

- 2) Adjusting point . . Normal L304 (L) and L404 (R) coils.
Special L305 (L) and L405 (R) coils.
Metal L306 (L) and L406 (R) coils.
- 3) Adjustment Adjust each coil
Normal +15dB at 14KHz for 400Hz.
Special +13dB at 15KHz for 400Hz.
Metal +15dB at 18KHz for 400Hz.

5. Recording Current Adjustment

- 1) Setting Set the tape deck to recording mode and apply a -10dB 400Hz input signal. After adjusting the REC LEVEL controls to obtain a -7dB output, drop the input level by 30dB.
2) Test tape MCT-606SA or AC512 (blank) High Bias Type.
3) Tape select pos . . . Special
4) Adjusting point . . VR303(L) and VR403(R) semifixed resistors.
5) Adjustment Record the 400Hz signal, and adjust the semi-fixed resistors so that the output level obtained during playback is the same as the recording monitoring output level.

6. Bias Current Adjustment

- 1) Setting Same as the setting for recording current adjustment above.
- 2) Test tape Normal MTT-501SP
Special MCT-606SA
Metal AC-711
- 3) Adjusting point . . Normal VR304 (L) and VR404 (R) semifixed resistors.
Special VR305 (L) and VR405 (R) semifixed resistors.
Metal VR306 (L) and VR406 (R) semifixed resistors.

- 4) Adjustment Normal within +0dB, +0.5dB at 6.3KHz level for 400Hz.
 Special within +0.25dB, -0.25 dB at 6.3KHz level for 400Hz.
 Metal within +0.25dB, -0.25 dB at 6.3KHz level for 400Hz.

:Adjust each semifixed resistor as follows.

- 3) Adjusting point . . Normal VR304 (L) and VR404 (R) semifixed resistors.
 Special VR305 (L) and VR405 (R) semifixed resistors.
 Metal VR306 (L) and VR406 (R) semifixed resistors.
- 4) Adjustment Record the 400Hz and 15kHz signals, and adjust the coils to obtain a level difference of within ± 0.3 dB at 15kHz in respect to 400Hz during playback.

7. Peaking Adjustment

- 1) Setting Same as the setting for recording current adjustment above.
 Normal MTT-501SP
 Special MCT-606SA
 Metal AC-711

8. Adjustment method of test signal

- With the TEST SW ON, adjust VR301 to obtain 4.9V across C124 and adjust VR302 to obtain 5.1V across C224. The adjusting range should be kept within $\pm 0.05V$. For the measurement, use the digital voltmeter.

ADJUSTING POINTS

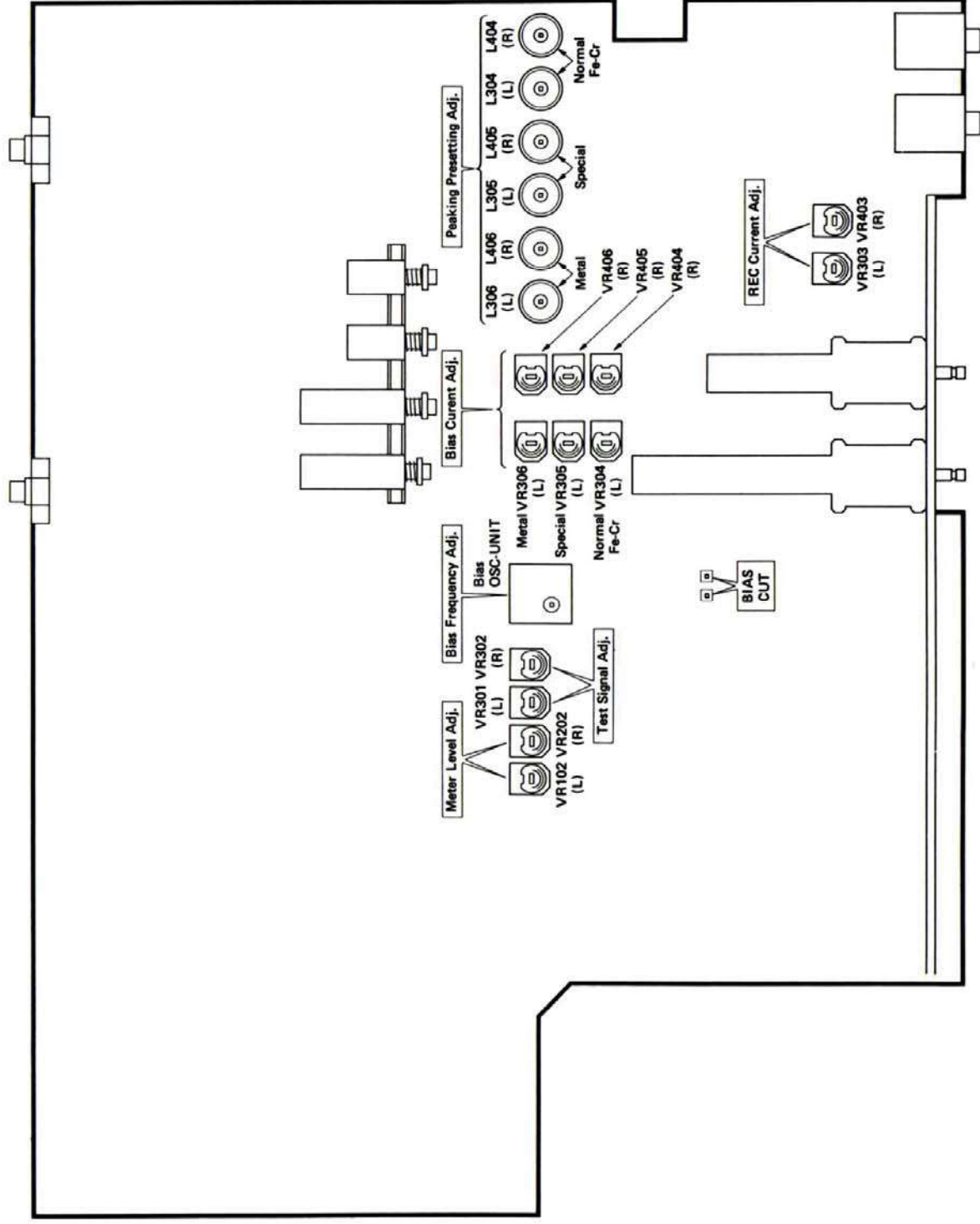

DOLBY B-C Adjustment

1. Encoder Setting

Adjustment Procedure

- 1) Turn off the Dolby NR Switch
- 2) Impress the 700 Hz signal on the line input terminal and adjust the ATT so that the TP 1 terminal of the encoder is at 0.775V (0dBm).
- 3) Adjust semifixed volume VR502 (L) and VR602 (R) so that the output of the TP 2 terminal becomes 0.775V \pm 0.25dB.
- 4) Adjust the ATT so that the output of the TP 2 terminal becomes 23.5mV and at the same time note down the output of the encoder.
- 5) Adjust VR501 (L) and VR601 (R) so that encoder output becomes +11dB against 4 when the Dolby NR switch is changed to the "C" position.

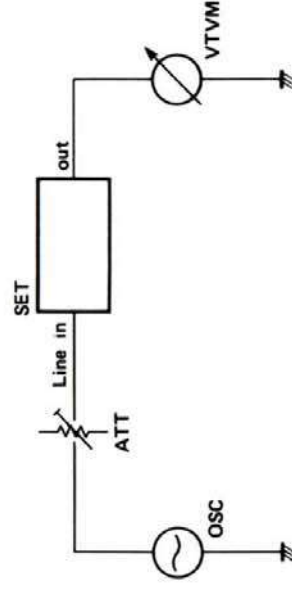

Fig. 21

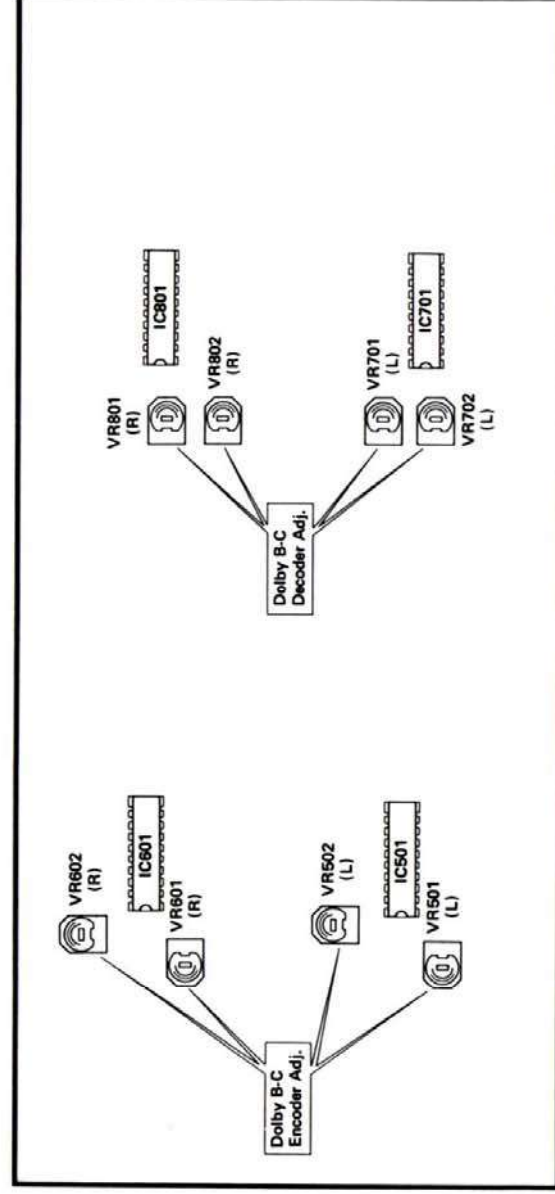
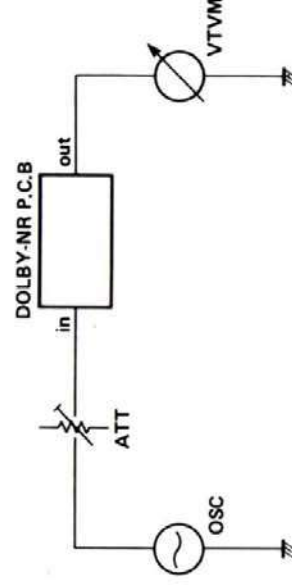

Fig. 22

2. Decoder Setting

Adjustment Procedure

- 1) Remove the decoder input terminal P102 from the main P.C.B.
- 2) Turn off the Dolby NR switch.
- 3) Impress the 700Hz signal on the Dolby NR P.C.B. terminal q (L) and Q (R), and adjust the ATT so that the output of TP 2 on the decoder side becomes 0.775V (0dBm).
- 4) Adjust semifixed volume VR701 (L) and VR801 (R) so that the output of terminal TP 1 becomes 0.775V.
- 5) Adjust the input ATT so that the output of terminal TP 1 becomes 83mV.
- 6) Adjust semifixed volume VR702 (L) and VR802 (R) so that the output of TP 1 becomes 23.5mV when the Dolby NR switch is turned to the "C" position.



BLOCK DIAGRAM

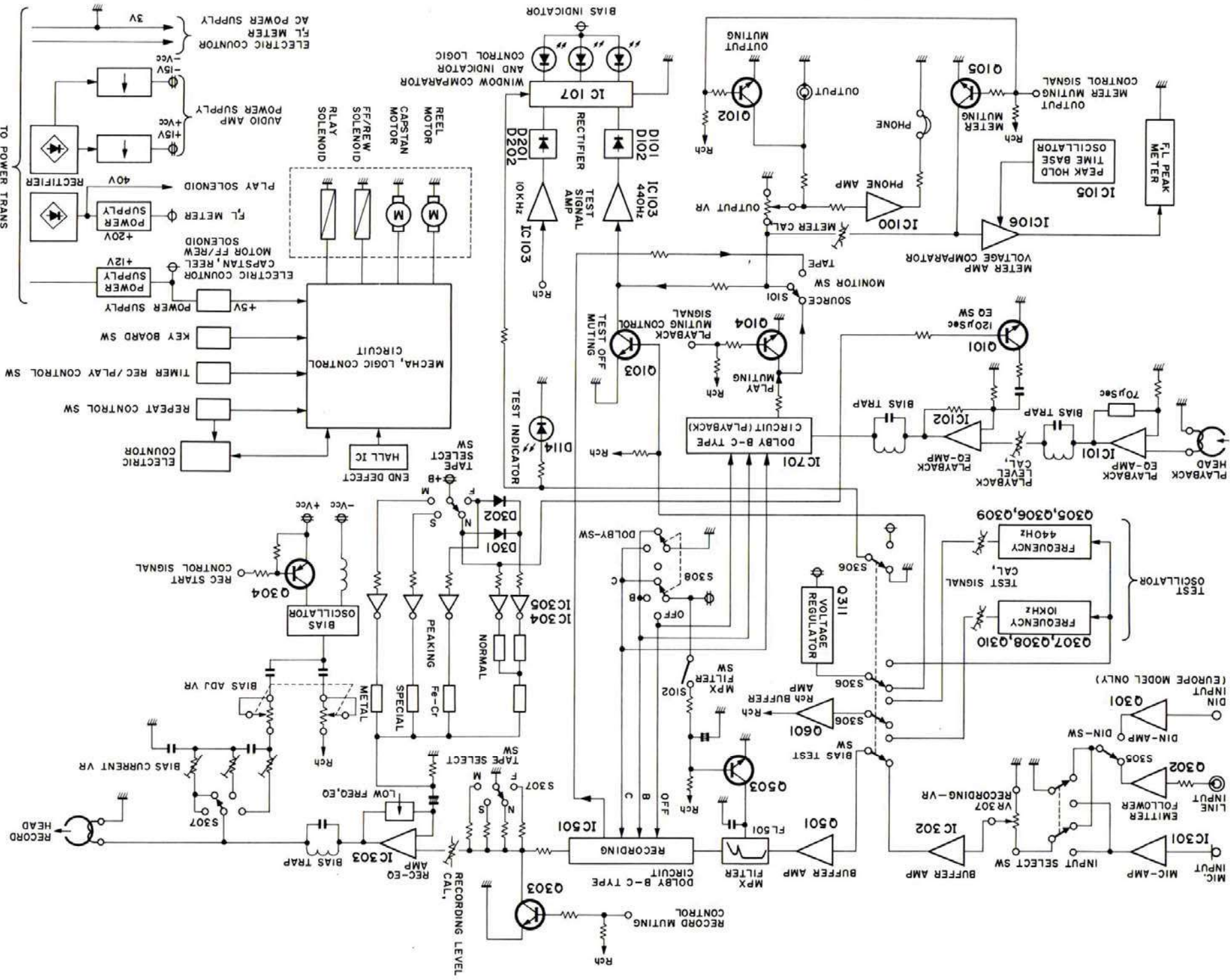

INTERNAL DIAGRAMS AND PIN OUT OF INTEGRATED CIRCUITS

BA6109 IC902

Input/Output Truth Table

F IN	R IN	Vout 1	Vout 2
H	H	L	L
L	H	L	H
H	L	H	L
L	L	OPEN	OPEN

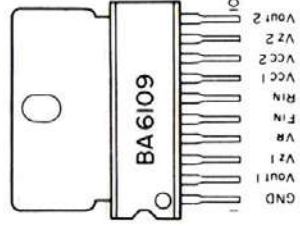

Circuit Construction

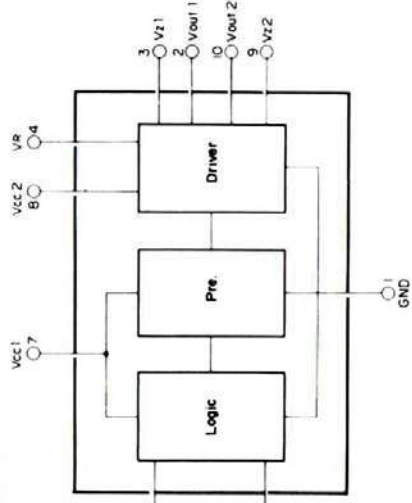

Internal Equivalent Circuit

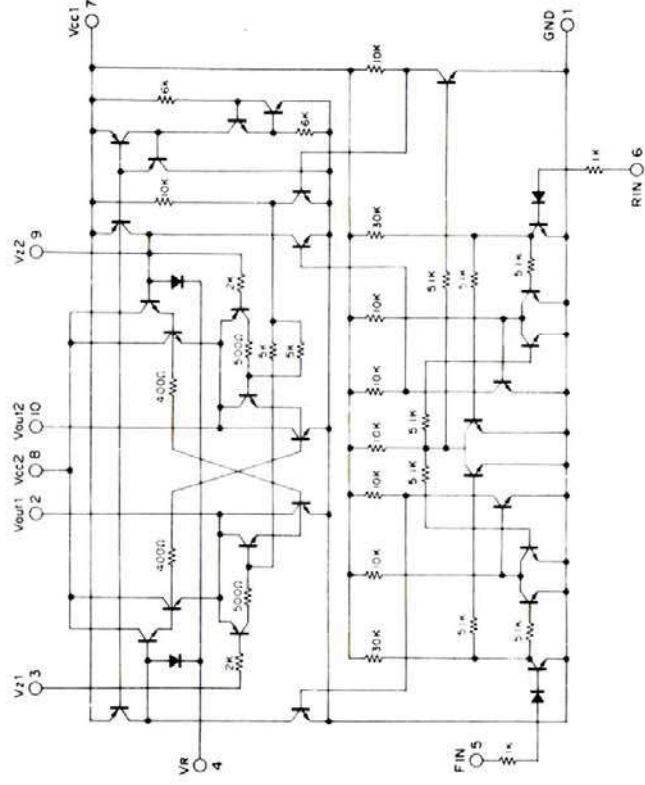

MPC4558 IC103

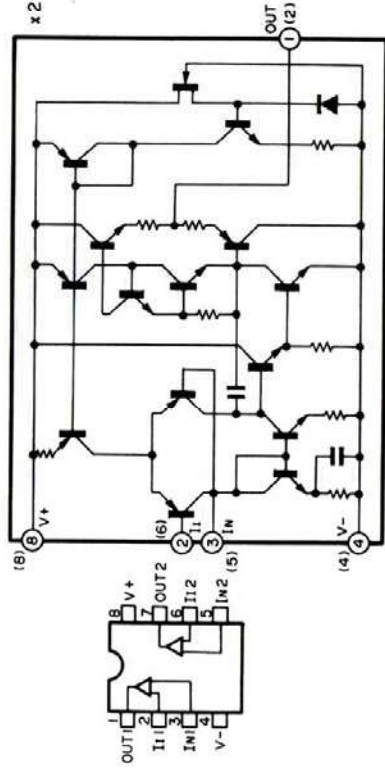

LB1450 IC107

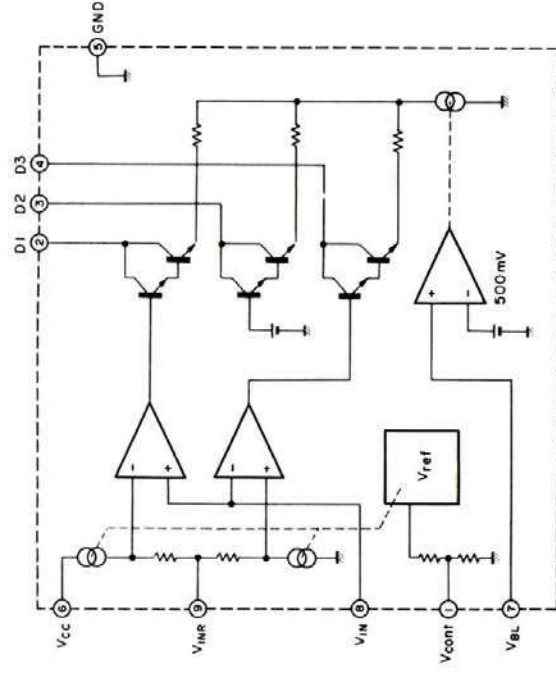

M54886P IC901

Circuit Construction

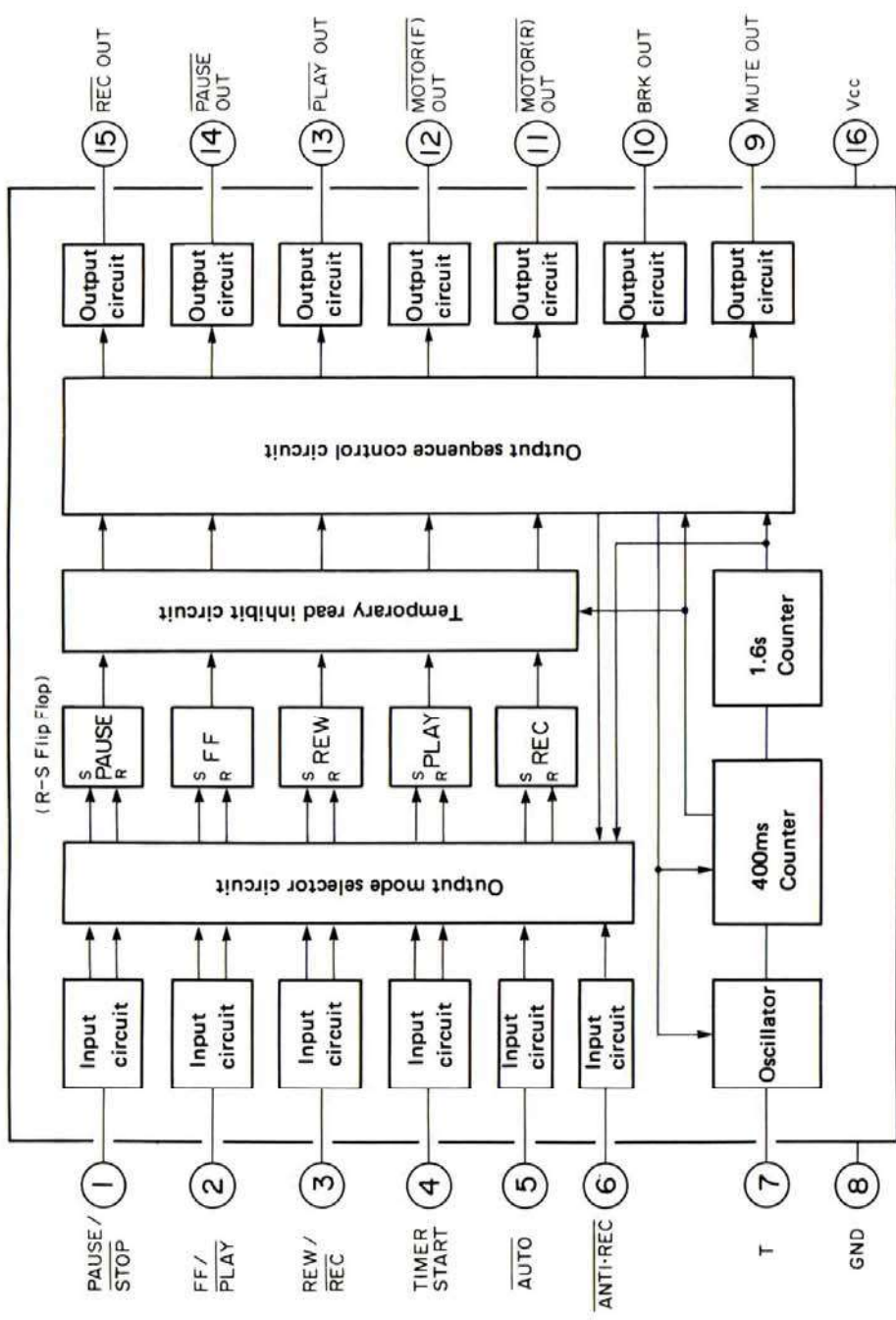

Input and Output Circuit Diagrams M54886P

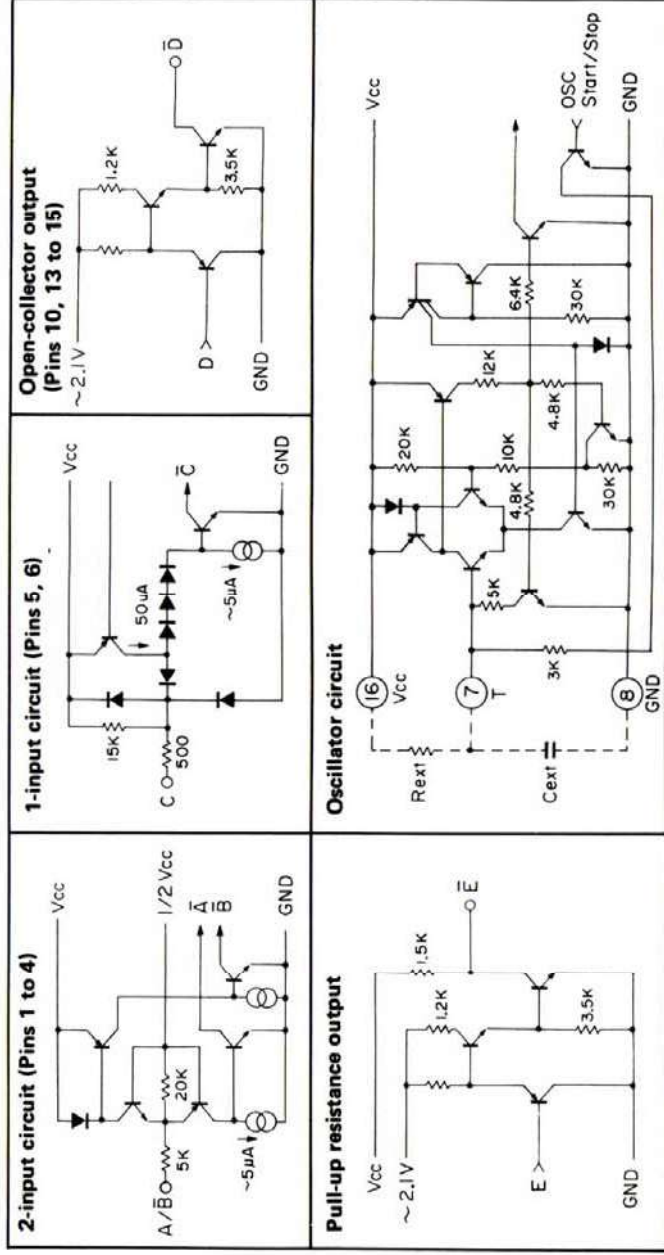

Terminal Description

Terminal No.	Name	Function
1	PAUSE/ $\overline{\text{STOP}}$	Pause mode selected at "H" level, and stop mode selected at "L" level.
2	FF/ $\overline{\text{PLAY}}$	Fast forward mode selected at "H" level, and play mode selected at "L" level.
3	RE/ $\overline{\text{REC}}$	Rewind mode selected at "H" level, and recording mode selected at "L" level. The $\overline{\text{REC}}$ input is valid only when applied together with the PAUSE or $\overline{\text{STOP}}$ input.
4	TIMER START	Selection of the operation mode when the power is switched on. Play mode is selected if left at "H" level, recording mode if left at "L" level, and stop mode if left open.
5	$\overline{\text{AUTO}}$	PLAY \rightarrow REW, REW \rightarrow PLAY or FF \rightarrow STOP mode change instruction is generated by the application of an "L" level pulse (\sqcap) to this input terminal.
6	$\overline{\text{ANTI REC}}$	Recording inhibit input terminal. Recording is inhibited when an "L" level signal is applied.
7	T	External resistors and capacitors are connected to this terminal to form the oscillator circuit.
8	GND	Earth
9	MUTE OUT	Muting signal output.
10	BRK OUT	Reel disk brake signal output.
11	$\overline{\text{MOTOR(F) OUT}}$	Reel motor forward drive signal output.
12	$\overline{\text{MOTOR(R) OUT}}$	Reel motor reverse drive signal output.
13	$\overline{\text{PLAY OUT}}$	PLAY signal output.
14	$\overline{\text{PAUSE OUT}}$	PAUSE signal output.
15	$\overline{\text{REC OUT}}$	Recording signal output.
16	V _{cc}	Power supply.

MPC457C IC104

TA78

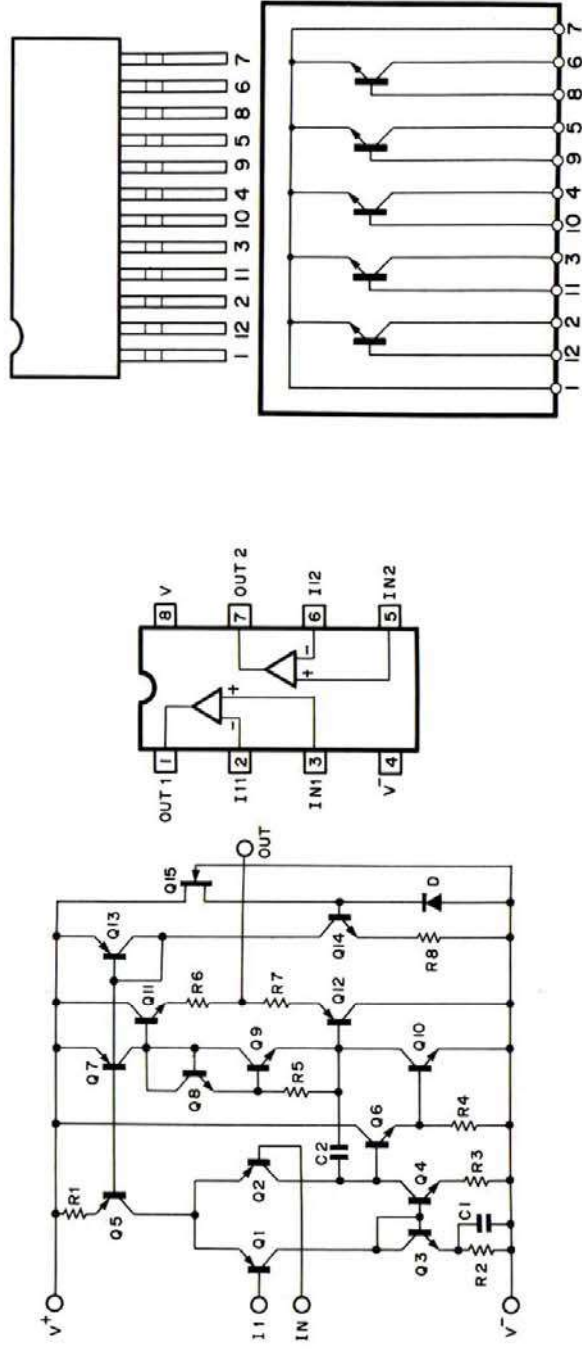

BA668 IC106

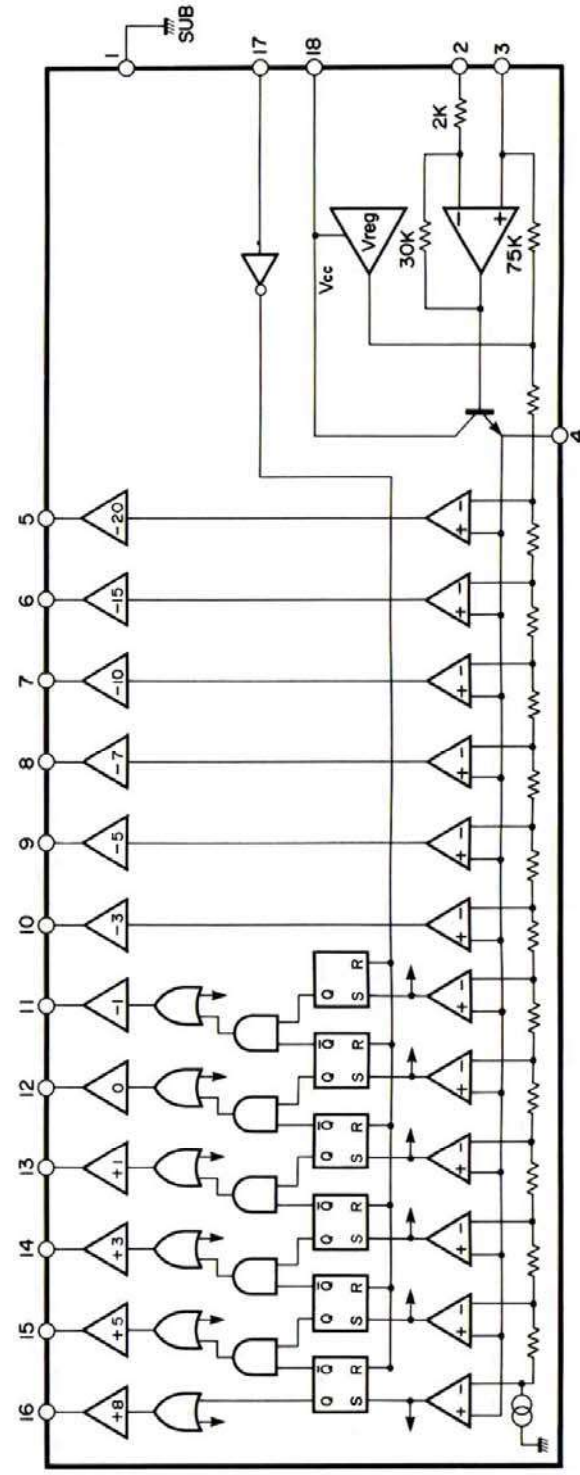

MPC1224H IC101,102,301,302,303

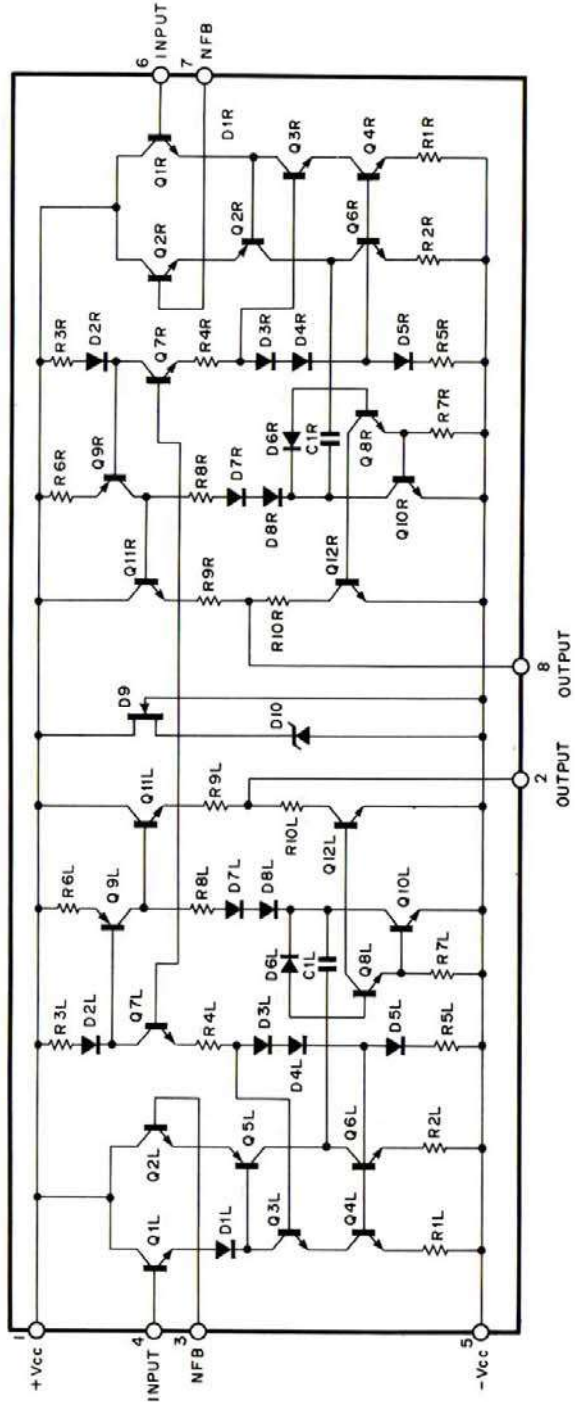

**MPC7812 IC12
MPC7815**

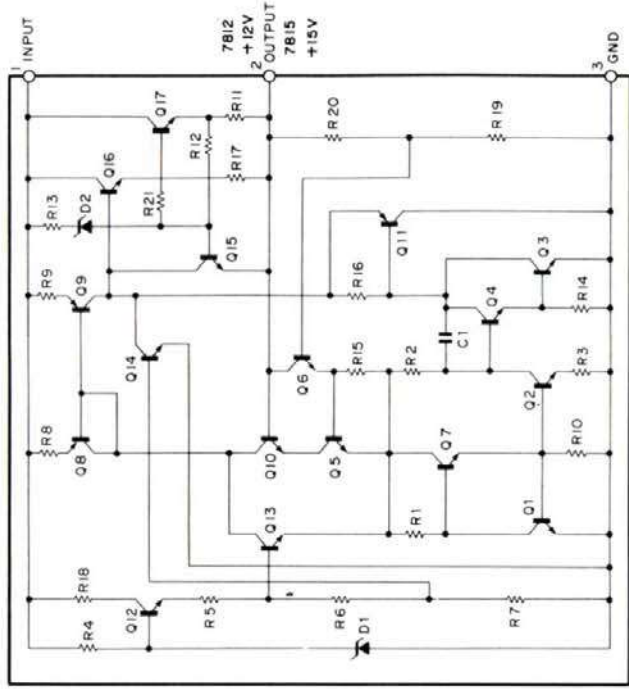
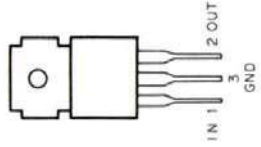

MPC7915 IC13

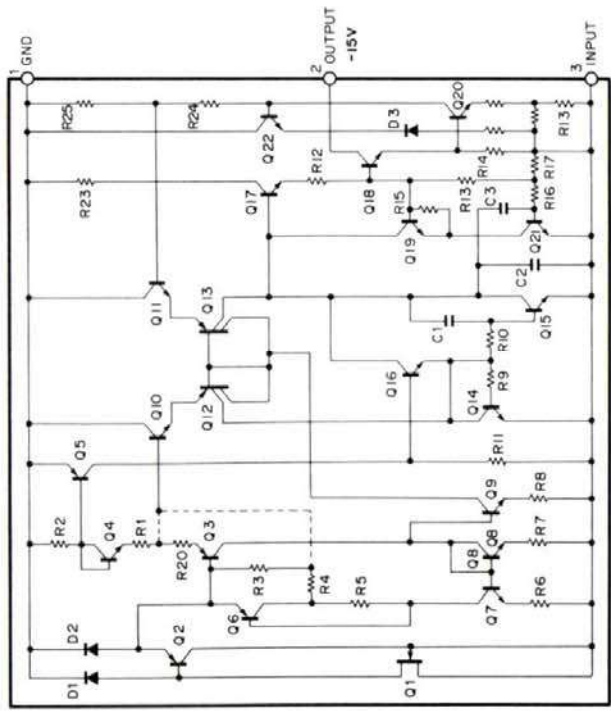
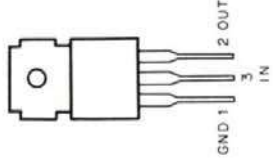

BA222 IC105

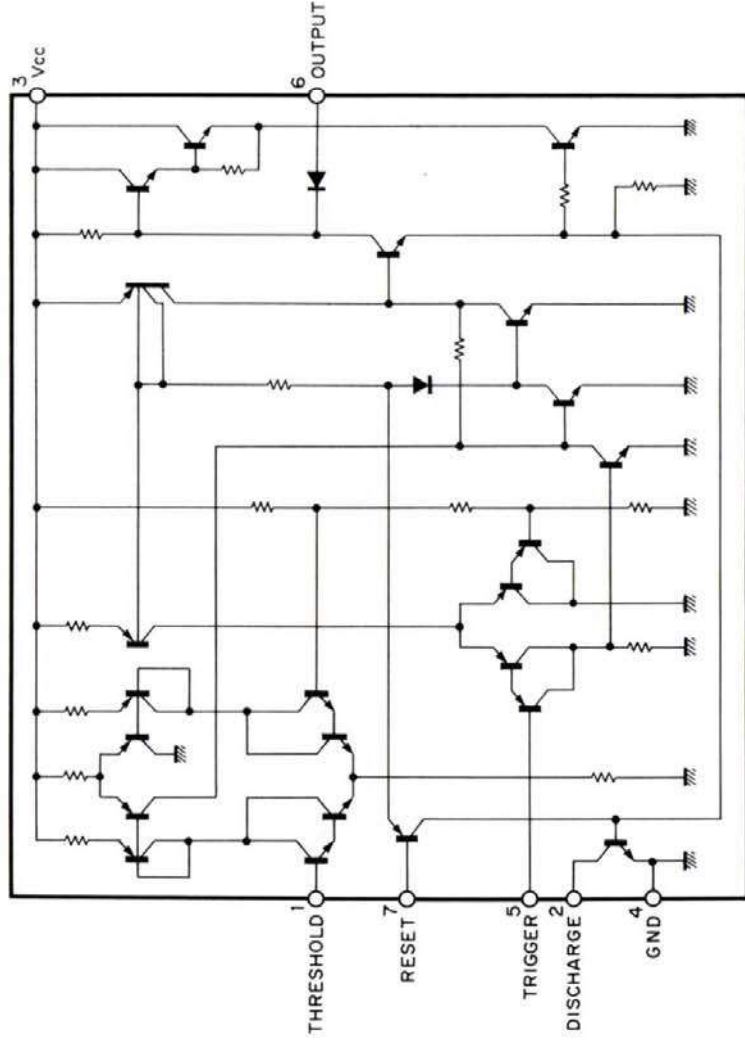

TM3140B IC903

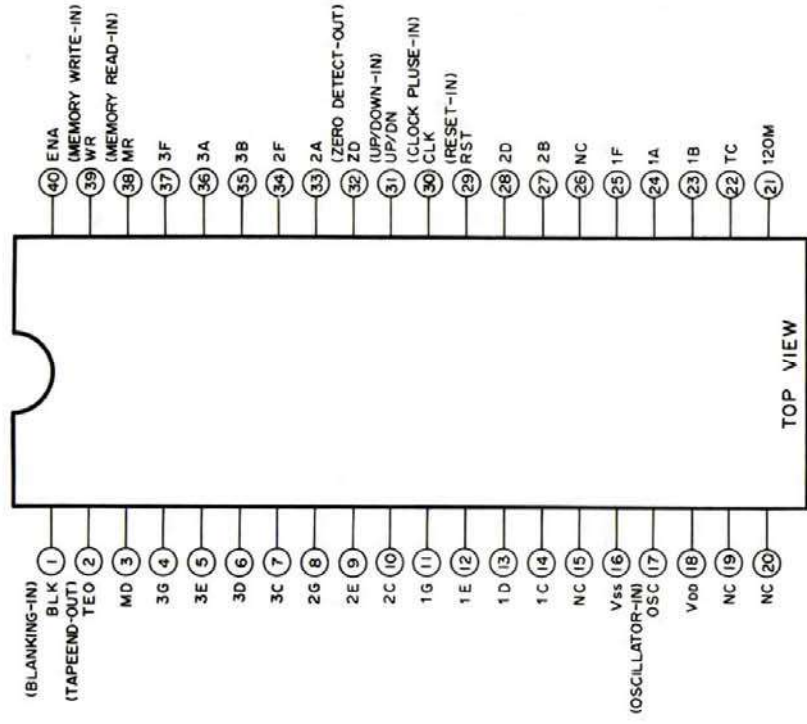

DIGIT	D1 ~ D3									
DIS-PLAY SEG-MENT	0	1	2	3	4	5	6	7	8	9
X A	○	○	○	○	○	○	○	○	○	○
X B	○	○	○	○	○	○	○	○	○	○
X C	○	○	○	○	○	○	○	○	○	○
X D	○	○	○	○	○	○	○	○	○	○
X E	○	○	○	○	○	○	○	○	○	○
X F	○	○	○	○	○	○	○	○	○	○
X G	○	○	○	○	○	○	○	○	○	○

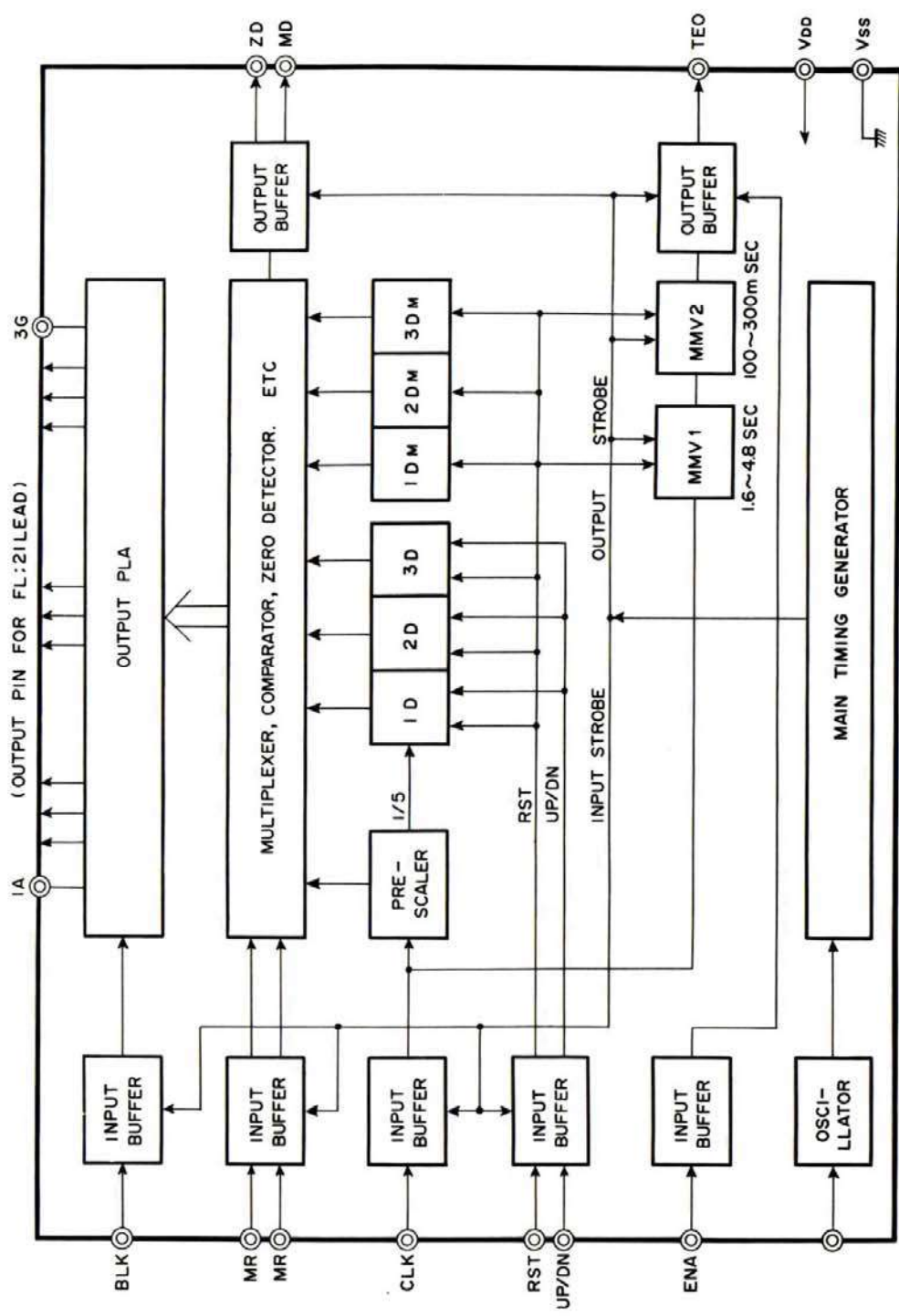

HA11226

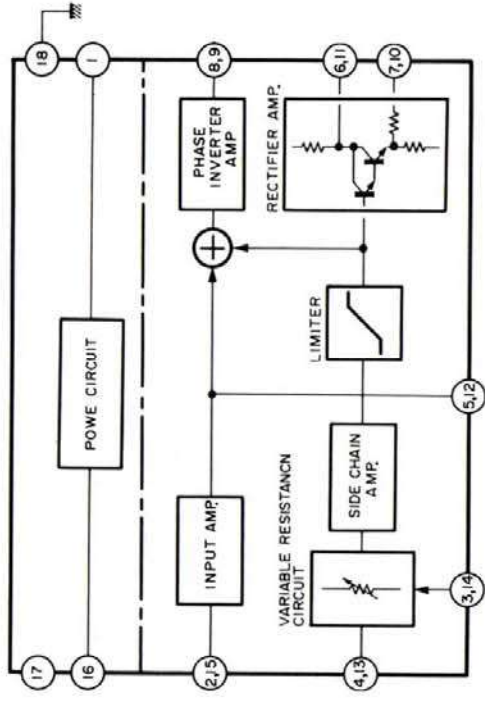
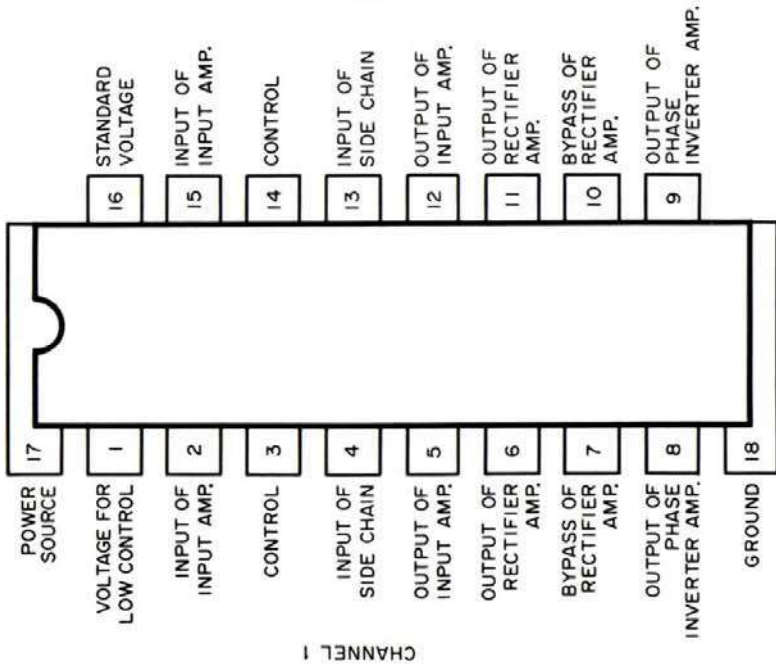

WIRING DIAGRAM

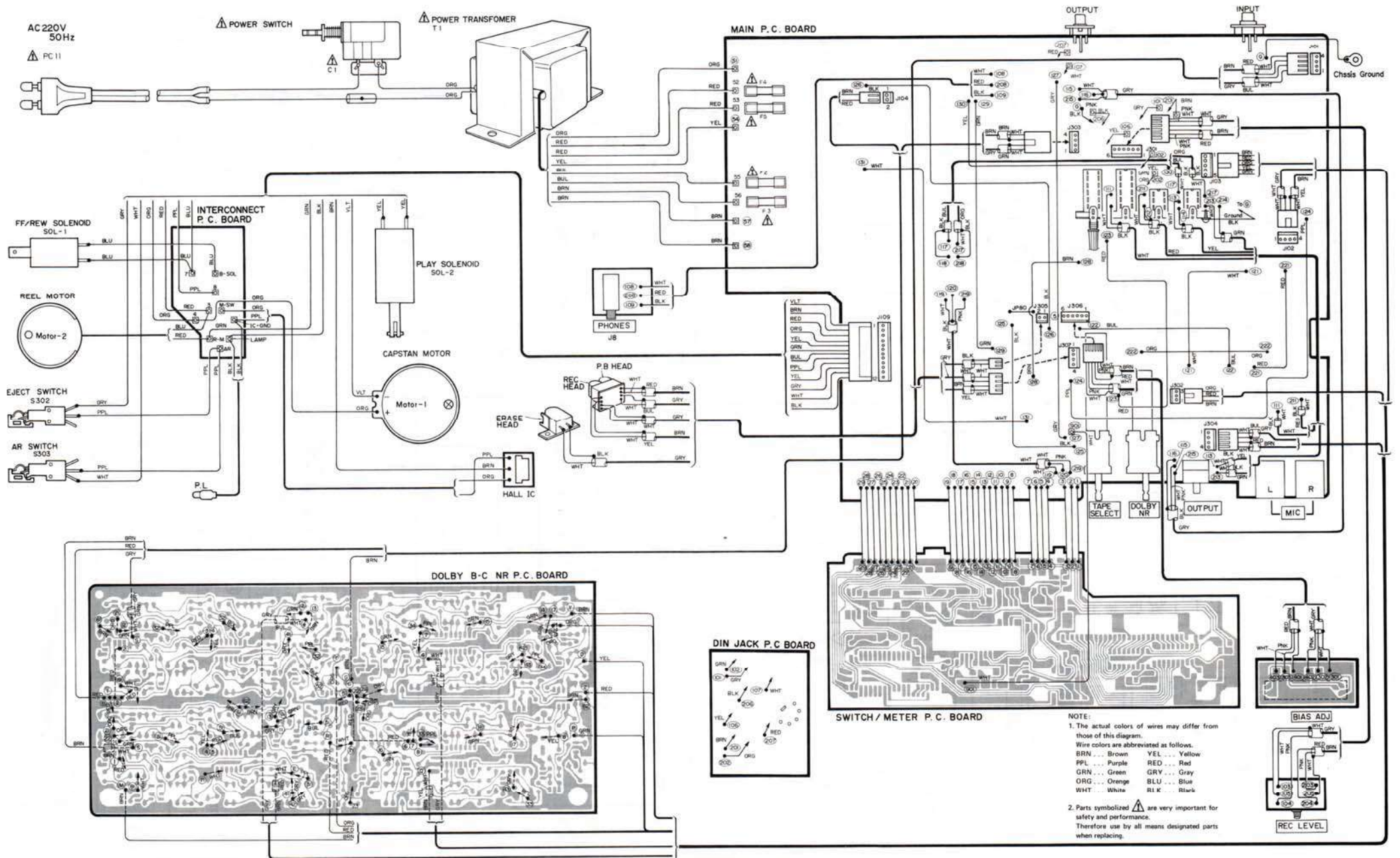

SCHEMATIC DIAGRAM

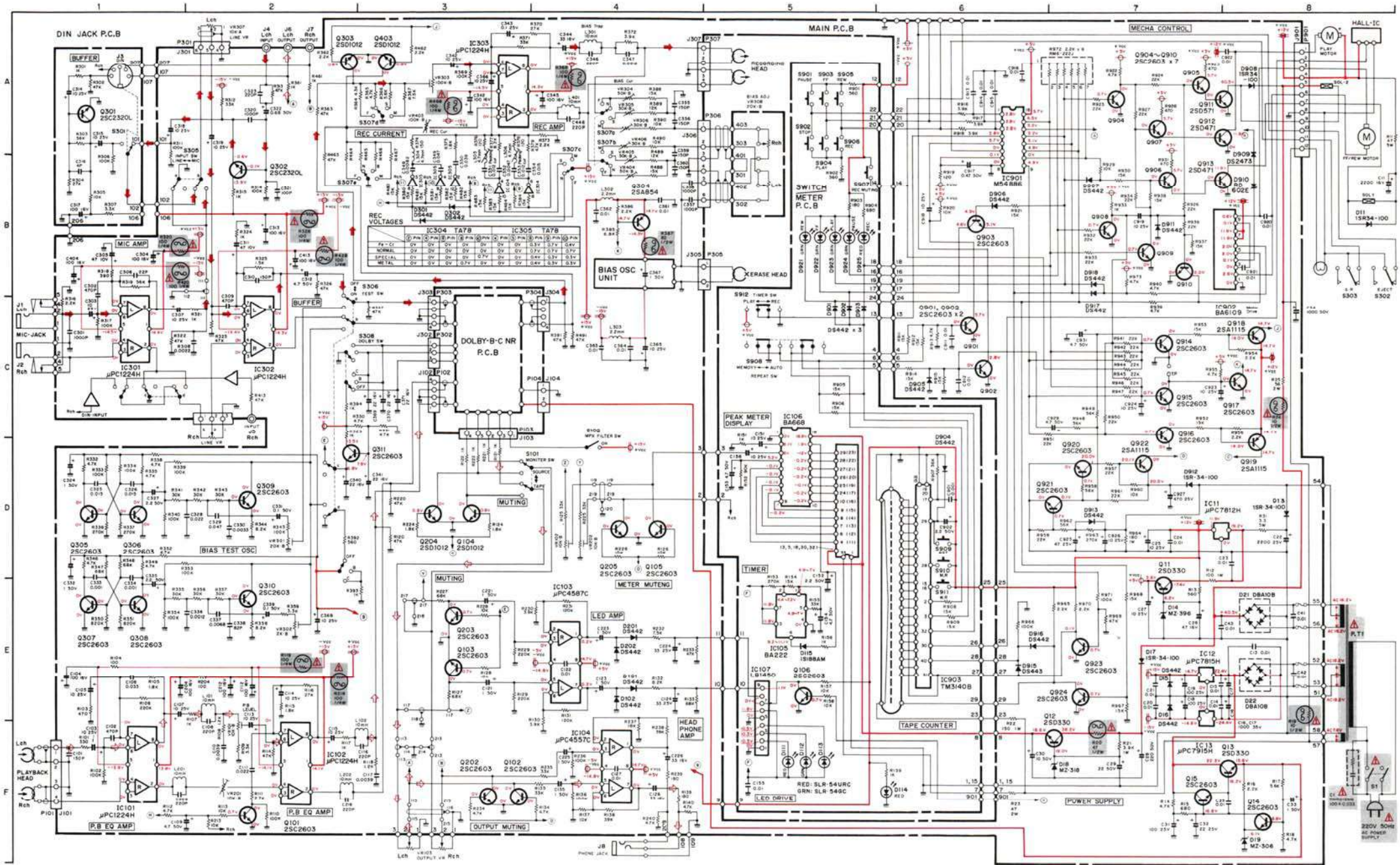

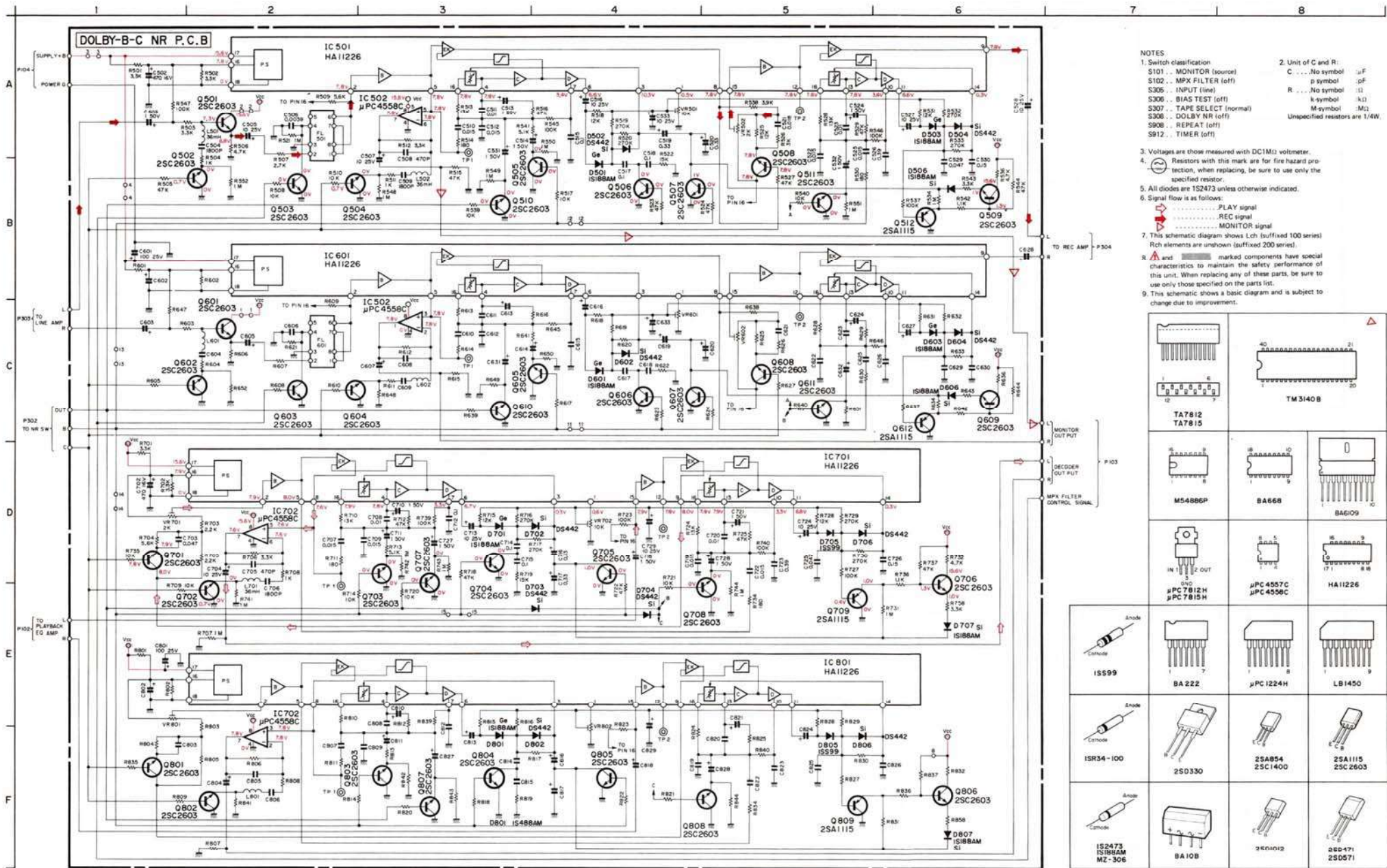

- NOTES
- Switch classification
 S101 - MONITOR (source)
 S102 - MPX FILTER (left)
 S305 - INPUT (line)
 S306 - BIAS TEST (left)
 S307 - TAPE SELECT (normal)
 S308 - DOLBY NR (left)
 S908 - REPEAT (left)
 S912 - TIMER (left)
 - Unit of C and R:
 C . . . No symbol μ F
 p symbol pF
 R . . . No symbol Ω
 k symbol k Ω
 M symbol M Ω
 Unspecified resistors are 1/4W.
- Voltages are those measured with DC1M Ω voltmeter.
 - Resistors with this mark are for fine hazard protection, when replacing, be sure to use only the specified resistor.
 - All diodes are 1S2473 unless otherwise indicated.
 - Signal flow is as follows:
 PLAY signal
 REC signal
 MONITOR signal
 - This schematic diagram shows Lch (suffixed 100 series) Rch elements are unknown (suffixed 200 series).
 - Δ and \square marked components have special characteristics to maintain the safety performance of this unit. When replacing any of these parts, be sure to use only those specified on the parts list.
 - This schematic shows a basic diagram and is subject to change due to improvement.

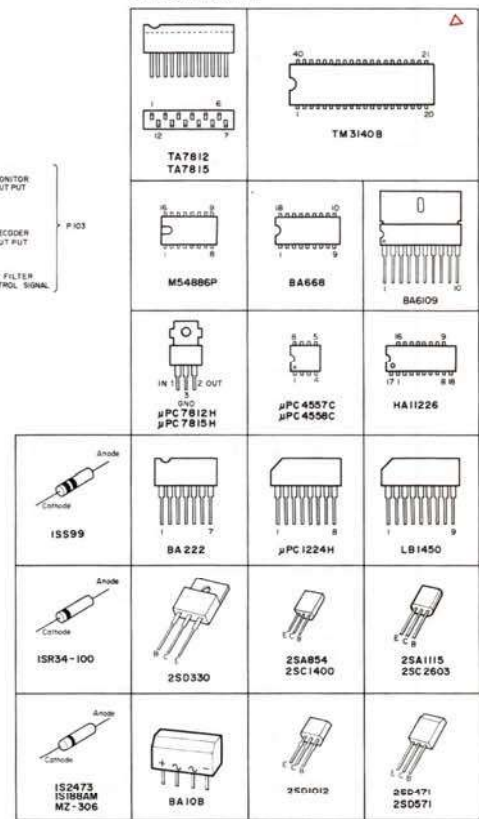

SWITCHING TRANSISTOR ENCODER

MODE	TR	Q502	Q504	Q510	Q503, 306, 507	Q508	Q511
DOLBY	OFF	OFF	OFF	OFF	OFF	ON	ON
DOLBY B	OFF	OFF	OFF	ON	OFF	ON	ON
DOLBY C	ON	ON	OFF	OFF	ON	OFF	OFF

DECODER

MODE	TR	Q701	Q703	Q704, 705	Q707	Q708
DOLBY	OFF	OFF	OFF	ON	ON	ON
B	OFF	ON	OFF	ON	ON	ON
C	ON	OFF	OFF	OFF	OFF	OFF

PRINTED CIRCUIT BOARDS

MAIN P.C. BOARD

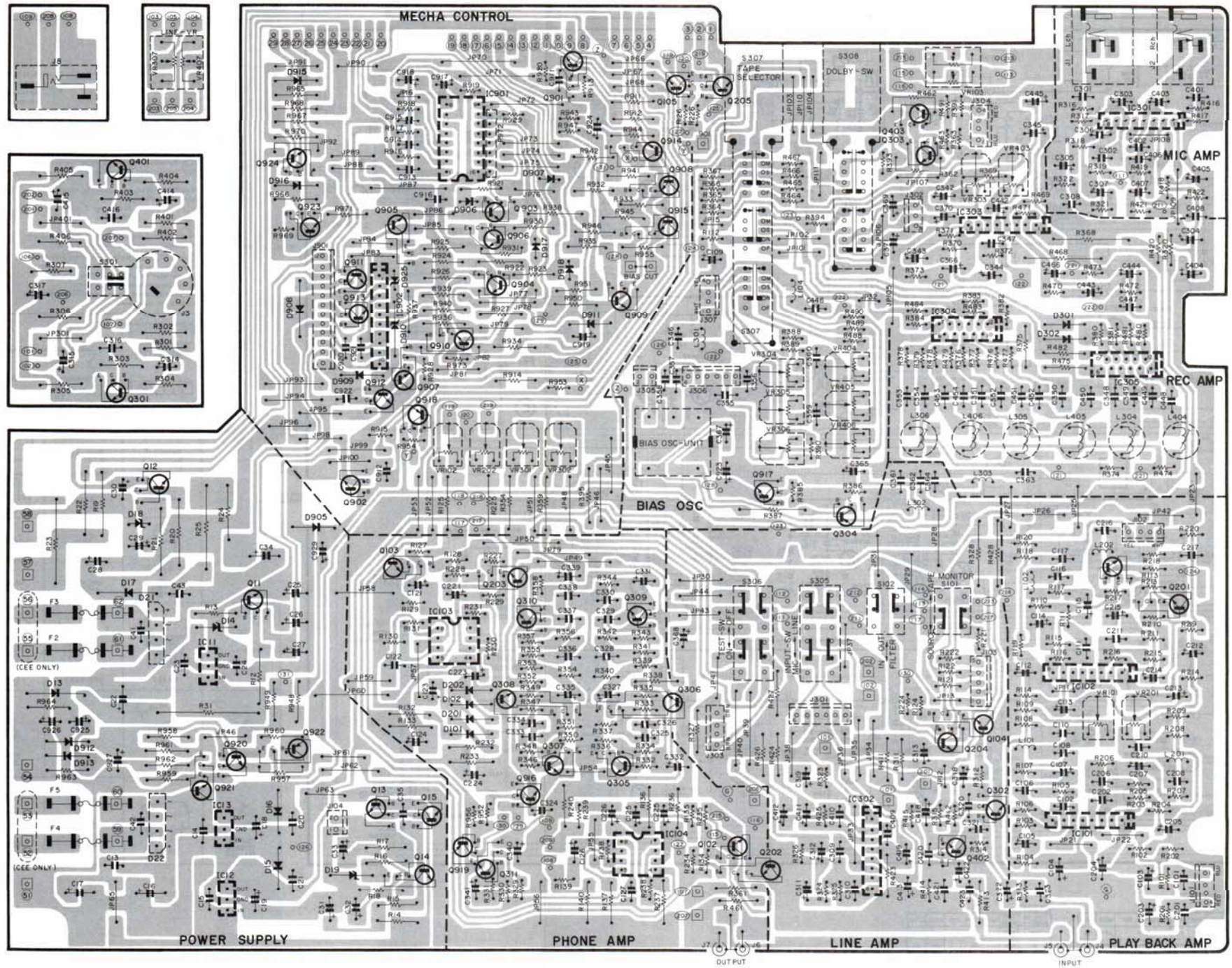

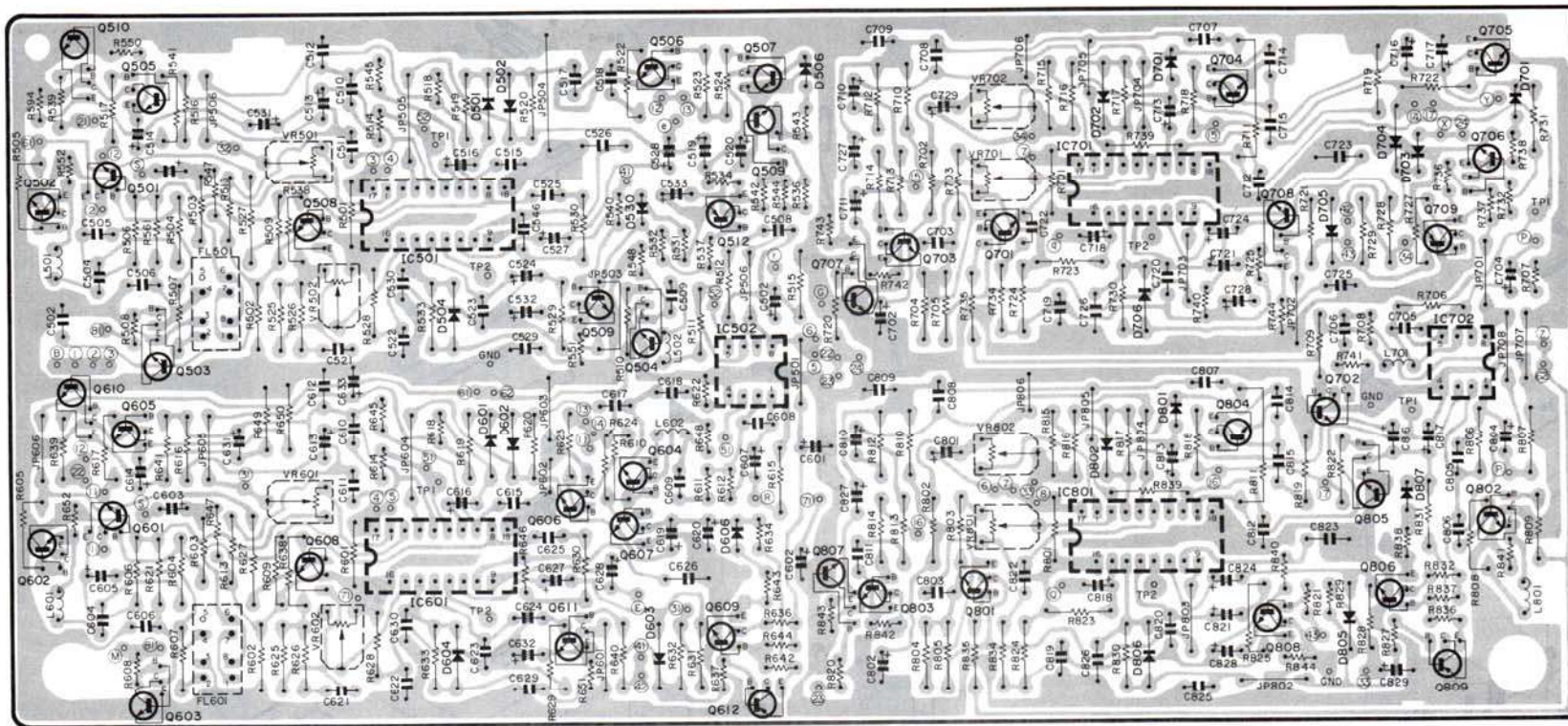

INTER CONNCT P.C.BOARD

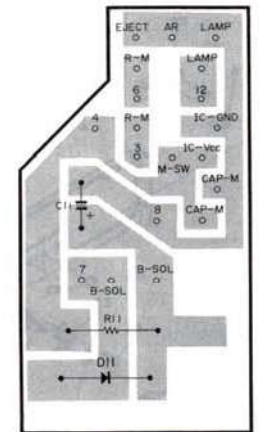

SWITCH/METER P.C. BOARD

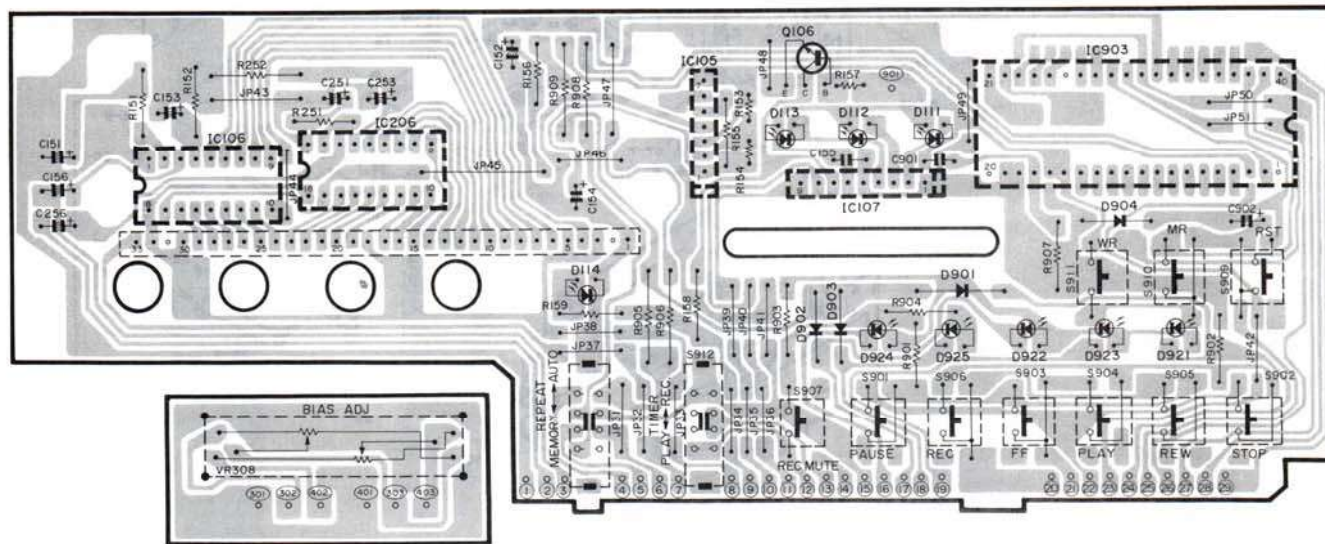

EXPLODED VIEW OF CABINET

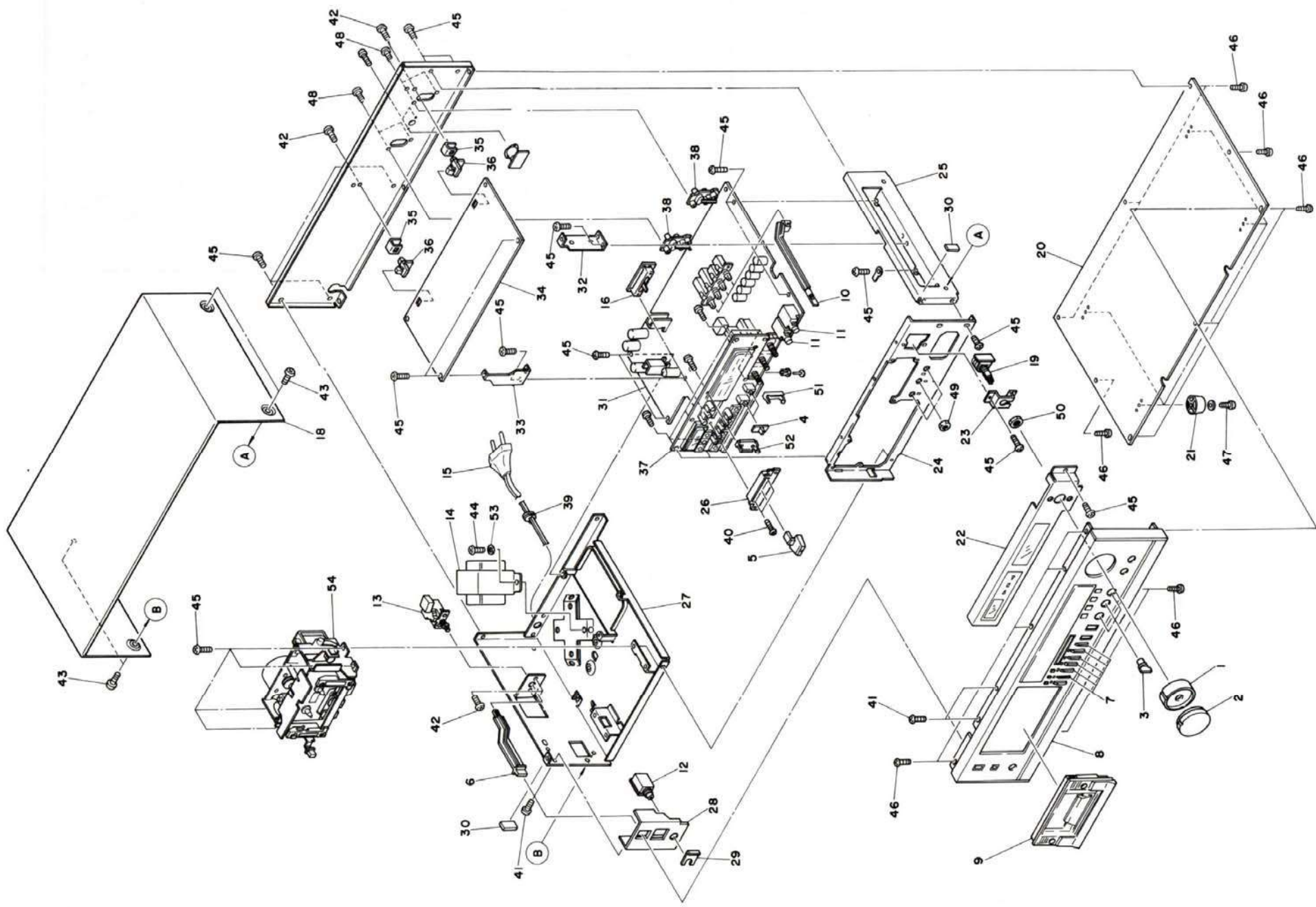

EXPLODED VIEW OF MECHANISM

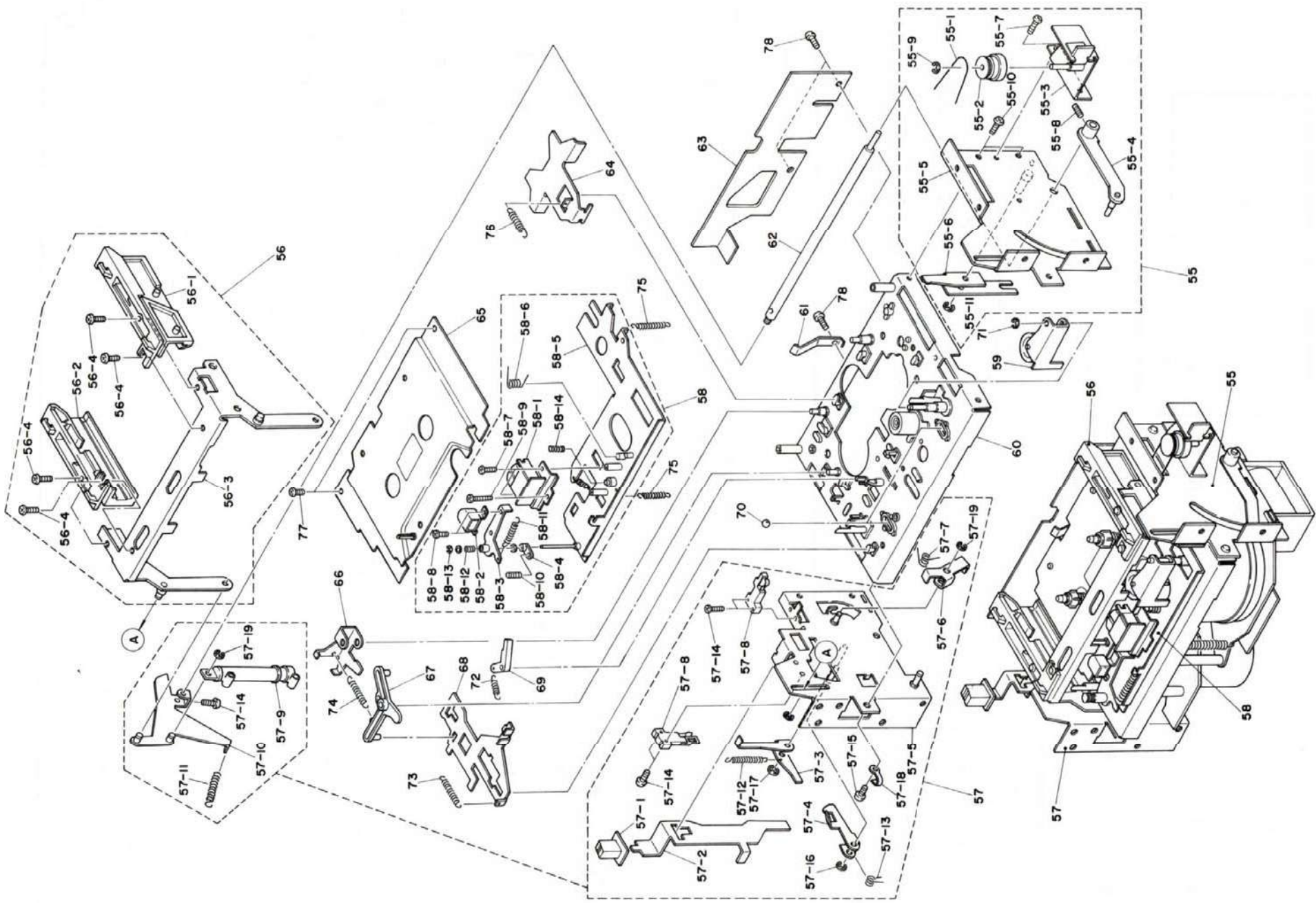

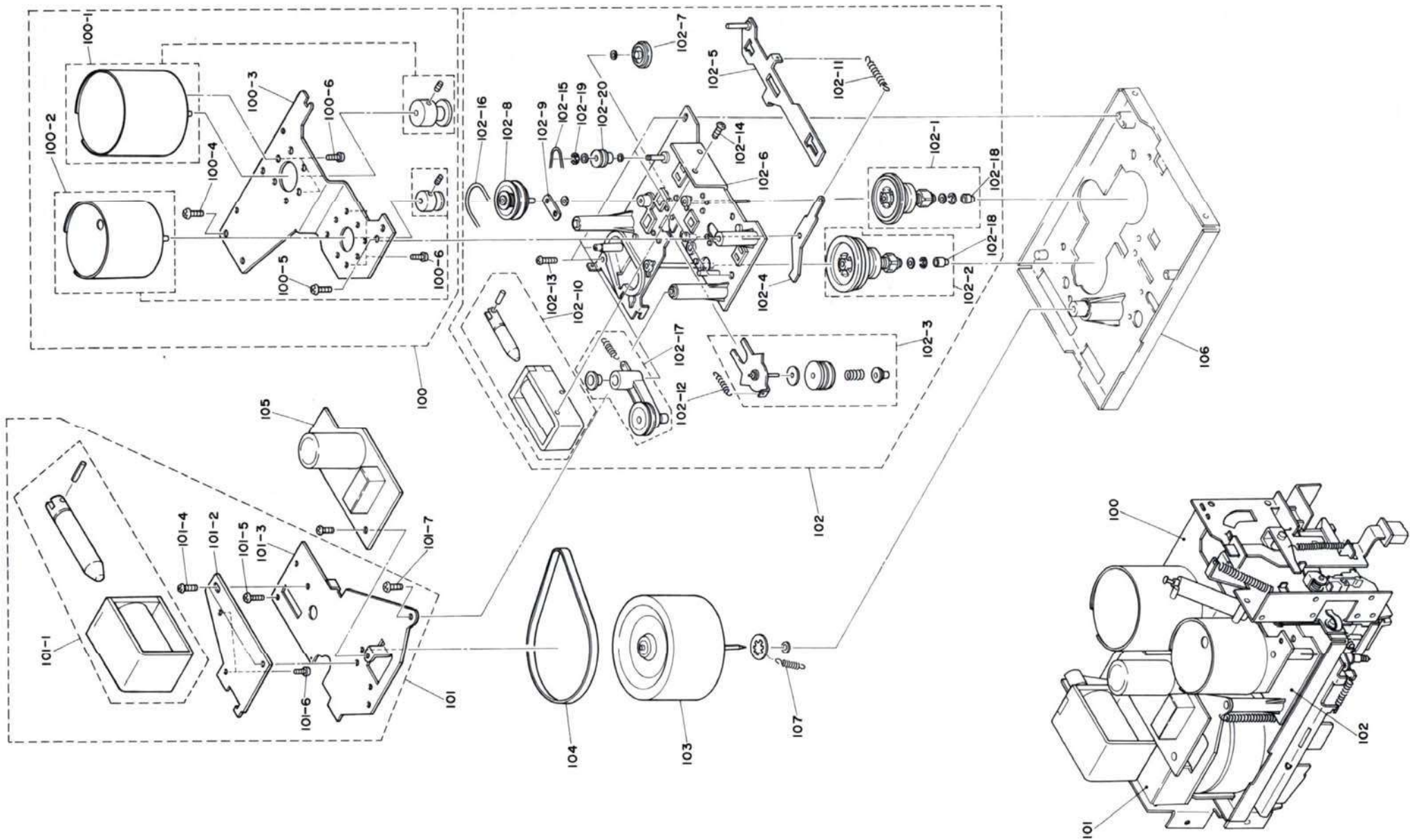

PARTS LIST

Symbol No.	Parts No.	Description
1	M05223200	Knob (Rec Level-L)
2	M05223201	Knob (Rec Level-R)
3	M05211201	Knob (Output, Dolby, Select)
4	M05211207	Knob (Timer, Repeat)
5	M05223205	Knob (Bias Adj.)
6	M05223203	Knob (Power)
7	M05223202	Knob (Mecha-Con.)
8	M05223100	Front Panel Ass'y
9		Cassette Cover Ass'y
10	M05223205	Knob (Bias Test, Input, MPX Filter, Monitor)
11	M05223475	Jack (Mic)
12	M05223476	Jack (Headphone)
13		SW-Push (Power)
14	M05200410	Power Transformer
15	M07461440	Power Cord
16		VR-Slide (Bias Adj.)
17	M05224102	Back Panel
18	M05211104	Top Cover
19		VR-307 (Rec Level)
20		Cabinet Bottom
21	M05104140	Leg
22		Inlay Ass'y
23		Holder
24		Panel (Front)
25		Holder-U (Said-R)
26		Holder
27		Base
28		Holder
29		Stopper
30		Gum Cushion
31		Main PCB
32		Holder
33		Holder
34		Dolby NR PCB
35		Holder-U (Side-L)
36		Hinge
37		Meter PCB
38	M07510475	Pin Jack
39		Clamper
40		Screw M2 x 6
41		Screw M3 x 5
42		Screw M3 x 6
43		Screw M4 x 6
44		Screw M4 x 10
45		Screw T2 - 3 x 6
46		Screw T2 - 3 x 8
47		Screw T2 - 3 x 14
48		Screw T1 - 3 x 8
49		Nut M7
50		Nut M9
51		Holder
52		Holder
53		Washer Spring
54		Mechanism Ass'y

Symbol No.	Parts No.	Description
55		Holder-L Ass'y
55-1	M05223713	Belt (End Stop)
55-2		Pully
55-3		Holder
55-4		Link
55-5		Holder
55-6		Link
55-7		Screw 2-3 x 6
55-8		Screw 2-3 x 6
55-9		E-Ring 2
55-10		Screw 2-3 x 6
55-11		E-Ring 3
56		Cassette Holder Ass'y
56-1	M05207147	Cassette Holder (Right)
56-2	M05207148	Cassette Holder (Left)
56-3		Holder
56-4		Screw M2.6 x 4
57		Holder-L Ass'y
57-1	M05211206	Knob (Eject)
57-2		Link
57-3		Lever
57-4		Lever
57-5		Holder-L Ass'y
57-6		Lever
57-7		Spring
57-8	M05202435	Micro SW
57-9	M04165625	Damper
57-10		Lever
57-11		Spring
57-12		Spring
57-13		Spring
57-14		Screw M2 x 8
57-15		Screw M2 x 8
57-16		E-Ring 2.5
57-17		E-Ring 3
57-18		Leg
57-19		E-Ring 2
58		Head Base Ass'y
58-1	M05223520	Rec/PB Head
58-2	M05223524	Erase Head
58-3		Lever
58-4		-
58-5		Base
58-6		Spring (Pinch Roller)
58-7		Screw M2 x 12
58-8		Screw M2 x 14
58-9		Screw M2 x 14
58-10		Washer Spring
58-11		Washer Spring
58-12		Washer Spring
58-13		E-Ring
58-14		Washer Spring
59	M05202540	Pinch Roller Ass'y
60		Mecha-Base
61		Spring
62		Shaft
63		Holder
64		Holder

Symbol No.	Parts No.	Description
65		Cover
66		Lever
67		Lever
68		Link
69		Lever
70	M07314627	Steel Ball
71		E-Ring 2.5
72		Washer Spring
73		Washer Spring
74		Washer Spring
75		Washer Spring
76		Washer Spring
77		Screw 1-2.6 x 5
78		Screw 2-3 x 5
79		E-Ring 2.5
100		Motor Ass'y
100-1	M05223550	Motor Ass'y (Capstan)
100-2	M05223551	Motor Ass'y (FF/REW)
100-3		Base
100-4		Screw 1-3 x 6
100-5		Screw 1-3 x 6
100-6		Screw M2.6 x 3
101		Solenoid Ass'y
101-1		Solenoid Ass'y
101-2		Holder
101-3		Holder
101-4		Screw M2.6 x 4
101-5		Screw 2-3 x 5
101-6		Screw M3 x 5
101-7		Screw 1-3 x 6
102		Base Ass'y
102-1	M05202527	Reel Rest
102-2	M05202526	Reel Rest
102-3		Pulley Ass'y (Take up)
102-4		Lever
102-5		Link
102-6		Base
102-7		Pulley
102-8		Pulley
102-9		-
102-10	M05223530	Solenoid
102-11		Spring
102-12		Spring
102-13		Screw 1-3 x 6
102-14		Screw 1-3 x 6
102-15	M05223714	Belt
102-16	M05174550	Belt
102-17		Pulley
102-18	M05163060	Hood
102-19		E-Ring
102-20		Pulley
103		Fly Wheel
104	M05202520	Belt
105	M05162550	PCB Ass'y
106		Base-Mechanism
107		Spring

PARTS LIST

NOTE: ⚠ and ■ marks components on Parts list have special characteristics to maintain the safety performance of this unit. When replacing any of these parts, be sure to use only those specified parts.

Symbol No.	Parts No.	Description
Diodes		
D11	M07391320	1SF34-100
D13	M07391320	1SF34-100
D14	M07391320	1SF34-100
D15	M05208327	DS442
D16	M07208327	DS442
D17	M07391320	1SF34-100
D18	M07151322	MZ-318
D19	M07492320	MZ-306
D21	M05223320	DBA10B
D22	M05223320	DBA10B
D101	M05208327	DS442
D102	M05208327	DS442
D111	M07520326	SLR-54URC
D112	M07460321	SLR-54GC
D113	M07520326	SLR-54URC
D114	M07520326	SLR-54URC
D115	M05142320	1S188AM
D201	M05208327	DS442
D202	M05208327	DS442
D301	M05208327	DS442
D302	M05208327	DS442
D501	M05142320	1S188AM
D502	M05208327	PS442
D503	M05142320	1S188AM
D504	M05208327	DS442
D506	M05142320	1S188AM
D601	M05142320	1S188AM
D602	M05208327	DS442
D603	M05142320	1S188AM
D604	M05208327	DS442
D606	M05142320	1S188AM
D701	M05142320	1S188A
D702	M05208327	DS442
D703	M05208327	DS442
D704	M05208327	DS442
D705	M05223322	1SS99
D706	M05208327	DS442
D707	M05142320	1S188AM
D801	M05142320	1S188AM
D802	M05208327	DS442
D805	M05223322	1SS99
D806	M05208327	DS442
D807	M05142320	1S188AM
D901	M05208327	DS442
D902	M05208327	DS442
D903	M05208327	DS442
D904	M05208327	DS442
D905	M05208327	DS442
D906	M05208327	DS442
D907	M05208327	DS442
D908	M07391320	1SF34-100
D909	M05208327	1S2473
D910	M05223321	RD6.2E
D911	M05208327	DS442
D912	M07391320	1SF34-100
D913	M05208327	DS442

Symbol No.	Parts No.	Description
D915	M05208327	DS442
D916	M05208327	DS442
D917	M05208327	DS442
D918	M052-8327	DS442
D921	M07460321	SLR-54GC
D922	M07460321	SLR-54GC
D923	M07460321	SLR-54GC
D924	M07460321	SLR-54GC
D925	M07520326	SLR-54URC
ICs:		
IC11	M05223319	MPC7812H
IC12	M05223317	MPC7815H
IC13	M05223318	MPC7915H
IC101	M05223315	MPC1224H
IC102	M05223315	MPC1224H
IC103	M07390344	MPC4557C
IC104	M07390344	MPC4557C
IC105	M05223311	BA222
IC106	M05223312	BA668
IC107	M05223313	LB1450
IC301	M05223315	MPC1224H
IC302	M05223315	MPC1224H
IC303	M05223315	MPC1224H
IC304	M05223316	TA78
IC305	M05223316	TA78
IC501	M05223310	HA11226
IC502	M07370343	MPC4558C
IC601	M05223310	HA11226
IC701	M05223310	HA11226
IC702	M07370343	MPC4558C
IC801	M05223310	HA11226
IC901	M05202345	M54886
IC902	M07527343	BA6109
IC903	M05223314	TM3140B
Transistors		
Q11	M07151310	2SD330
Q12	M07151310	2SD330
Q13	M07151310	2SD330
Q14	M07390303	2SC2603
Q15	M07390303	2SC2603
Q101	M07390303	2SC2603
Q102	M07390303	2SC2603
Q103	M07390303	2SC2603
Q104	M07454303	2SD1012
Q105	M07390303	2SC2603
Q106	M07390303	2SC2603
Q202	M07390303	2SC2603
Q203	M07390303	2SC2603
Q204	M07454303	2SD1012
Q205	M07390303	2SC2603
Q301	M07390303	2SC2320L
Q302	M07390303	2SC2320L

Symbol No.	Parts No.	Description
Q303	M07454303	2SD1012
Q304	M07137308	2SA854
Q305	M07390303	2SC2603
Q306	M07390303	2SC2603
Q307	M07390303	2SC2603
Q308	M07390303	2SC2603
Q309	M07390303	2SC2603
Q310	M07390303	2SC2603
Q311	M07390303	2SC2603
Q403	M07454303	2SD1012
Q501	M07390303	2SC2603
Q502	M07390303	2SC2603
Q503	M07390303	2SC2603
Q504	M07390303	2SC2603
Q505	M07390303	2SC2603
Q506	M07390303	2SC2603
Q507	M07390303	2SC2603
Q508	M07390303	2SC2603
Q509	M07390303	2SC2603
Q510	M07390303	2SC2603
Q511	M07390303	2SC2603
Q512	M07390304	2SA1115
Q601	M07390303	2SC2603
Q602	M07390303	2SC2603
Q603	M07390303	2SC2603
Q604	M07390303	2SC2603
Q605	M07390303	2SC2603
Q606	M07390303	2SC2603
Q607	M07390303	2SC2603
Q608	M07390303	2SC2603
Q609	M07390303	2SC2603
Q610	M07390303	2SC2603
Q611	M07390303	2SC2603
Q612	M07390304	2SA1115
Q701	M07390303	2SC2603
Q702	M07390303	2SC2603
Q703	M07390303	2SC2603
Q704	M07390303	2SC2603
Q705	M07390303	2SC2603
Q706	M07390303	2SC2603
Q707	M07390303	2SC2603
Q708	M07390303	2SC2603
Q709	M07390304	2SA1115
Q801	M07390303	2SC2603
Q802	M07390303	2SC2603
Q803	M07390303	2SC2603
Q804	M07390303	2SC2603
Q805	M07390303	2SC2603
Q806	M07390303	2SC2603
Q807	M07390303	2SC2603
Q808	M07390303	2SC2603
Q809	M07390304	2SA1115
Q901	M07390303	2SC2603
Q902	M07390303	2SC2603
Q903	M07390303	2SC2603
Q904	M07390303	2SC2603
Q905	M07390303	2SC2603
Q906	M07390303	2SC2603
Q907	M07390303	2SC2603
Q908	M07390303	2SC2603
Q909	M07390303	2SC2603
Q910	M07390303	2SC2603

Symbol No.	Parts No.	Description
Q911	M07228303	2SD571
Q912	M05147311	2SD471
Q913	M05147311	2SD471
Q914	M07390303	2SC2603
Q915	M07390303	2SC2603
Q916	M07390303	2SC2603
Q917	M07390303	2SC2603
Q918	M07390304	2SA1115
Q919	M07390304	2SA1115
Q920	M07390303	2SC2603
Q921	M07390303	2SC2603
Q922	M07390304	2SA1115
Q923	M07390303	2SC2603
Q924	M07390303	2SC2603
Electrical Parts		
C11	M05209370	C-Elect-16V 2200 μ F
F2	M07324490	Fuse-1.6A-SEMKO
F3	M07324490	Fuse-1.6A-SEMKO
F4	M04167490	Fuse-800mA-SEMKO
F5	M04167490	Fuse-800mA-SEMKO
FL501	M05223445	Filter
FL601	M05223445	Filter
J1	M05223475	Jack (Mic-L)
J2	M05223475	Jack (Mic-R)
J3	M05175585	DIN Jack
J4	M07510475	Pin-Jack (Input-L)
J5	M07510475	Pin-Jack (Input-R)
J6	M07510475	Pin-Jack (Output-L)
J7	M07510475	Pin-Jack (Output-R)
J8	M05223476	Jack (Phones)
L	M05202490	Lamp-8V 150mA
R19	M07133420	R-Fuse-1/2W 10 Ω
R20	M07113411	R-Fuse-1/2W 47 Ω
R24	M07133420	R-Fuse-1/2W 10 Ω
R119	M05129471	R-Fuse-1/4W
R219	M05129471	R-Fuse-1/4W
R320	M05129471	R-Fuse-1/4W
R328	M05129471	R-Fuse-1/4W
R368	M05129471	R-Fuse-1/4W
R387	M05224455	R-Fuse-1/2W 82k Ω
R420	M05129471	R-Fuse-1/4W 100 Ω
R428	M05129471	R-Fuse-1/4W 100 Ω
R468	M05129471	R-Fuse-1/4W 100 Ω
S1	M05113430	SW-Push (Power)
S101	M07182450	SW-Push (Monitor)
S102	M07182450	SW-Push (MPX Filter)
S302	M05202435	SW-Micro (Eject)
S303	M05202435	SW-Micro (A, R)
S305	M05223355	SW-Push (Input)
S306	M05223355	SW-Push (Bias Test)
S307	M05202433	SW-Rotary (Tape Select)
S308	M05223365	SW-Rotary (Dolby NR)

Symbol No.	Parts No.	Description
S901	M07520454	SW-Push (Pause)
S902	M07520454	SW-Push (Stop)
S903	M07520454	SW-Push (FF)
S904	M07520454	SW-Push (Play)
S905	M07520454	SW-Push (REW)
S906	M07520454	SW-Push (REC)
S907	M07520454	SW-Push (REC Muting)
S908	M05202434	SW-Slide (Repeat)
S909	M07520454	SW-Push (RST)
S910	M07520454	SW-Push (M.R)
S911	M07520454	SW-Push (W.R)
S912	M05202434	SW-Slide (Timer)
SOL1	M05223530	Solenoid (FF/Rew)
SOL2	M05223531	Solenoid (Capstan)
T1	M05201410	Trans-Power Δ
VR101	M05200352	VR-W-A10K
VR103	M05223400	VR-W-A50K20 (Output)
VR201	M02003360	VR-Semi-B10K
VR301	M05175360	VR-Semi-B20K
VR302	M07440437	VR-Semi-B2K
VR303	M05175362	VR-Semi-B100K
VR304	M05175361	VR-Semi-B50K
VR305	M05184360	VR-Semi-B30K
VR306	M05184360	VR-Semi-B30K
VR307	M05200352	VR-W-A10K (Line)
VR308	M05223401	VR-Slide-B20K (Bias ADJ)
VR403	M05175362	VR-Semi-B100K
VR404	M05175361	VR-Semi-B50K
VR405	M05184360	VR-Semi-B30K
VR406	M05184360	VR-Semi-B30K
VR501	M05200360	VR-Semi-B10K
VR502	M07440437	VR-Semi-B2K
VR601	M05200360	VR-Semi-B10K
VR602	M07440437	VR-Semi-B2K
VR701	M07440437	VR-Semi-B2K
VR702	M05200360	VR-Semi-B10K
VR801	M07440437	VR-Semi-B2K
VR802	M05200360	VR-Semi-B10K
C1	M05224510	OSC Unit
	M05200470	CR-Multiple
	M05223520	Head-R/P
	M05176831	Head-E
	M05223340	Tube-FL (Level)
	M05223341	Tube-FL (Counter)
Packing		
	M05223900	Packing-Box
	M05211920	Packing-Bag
	M05211910	Cushion-Mold
	M05211911	Cushion-Mold
	M05223940	Instruction Booklet
	M05224945	Card-Warranty

PACKING INSTRUCTIONS

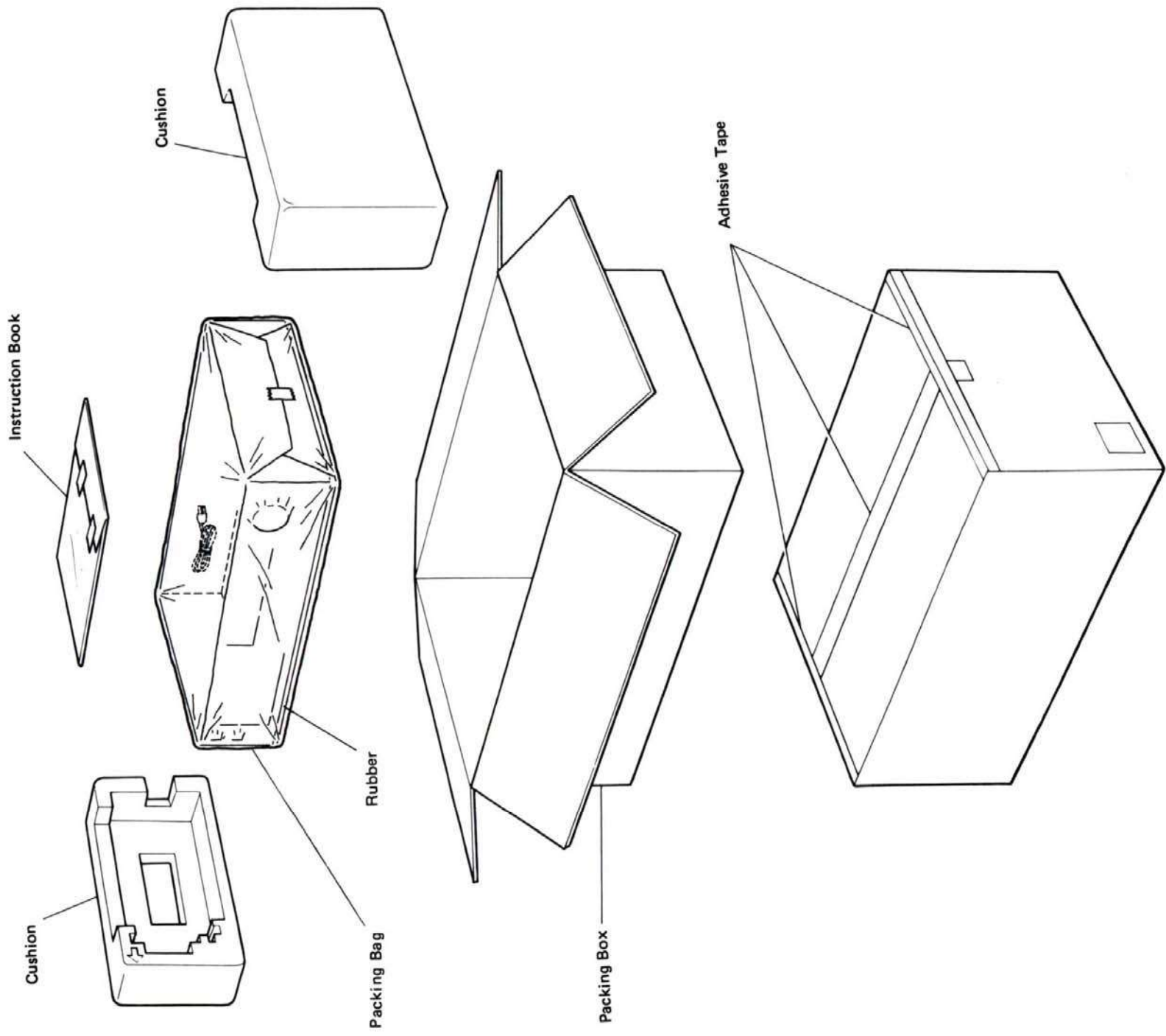

 **MITSUBISHI ELECTRIC CORPORATION**
HEAD OFFICE MITSUBISHI DENKI BLDG. MARUNOUCHI, TOKYO 100 TELEX JZ4532 CABLE MELCO TOKYO

DT-35-WG-E
SM-1043
Printed in Japan