

# AKAI SERVICE MANUAL



FM AM STEREO SYNTHESIZER TUNER

MODEL **AT-S7/L**

## ABBREVIATIONS FOR SERVICE MANUAL MODEL AT-S7/L

ABBREVIATION	EXPLANATION
FM	Frequency Modulation
ST.	STereo
IF	Intermediate Frequency
AM	Amplitude Modulation
Mod.	Modulation
S.S.G	Standard Signal Generator
AC	Alternating Current
MW	Medium Wave
LW	Long Wave
SENS.	SENSitivity
OSC	OSCillator
IND	INDicator
FREQ.	FREQuency
"L"	Low
"H"	High
L	Left
R	Right
CH	CHannel
CAL	CALibration
FLD	FLuorescent Display
PLL	Phase Locked Loop
VCO	Voltage Controlled Oscillator
AGC	Automatic Gain Control
RF	Radio Frequency
LIM	LIMiter

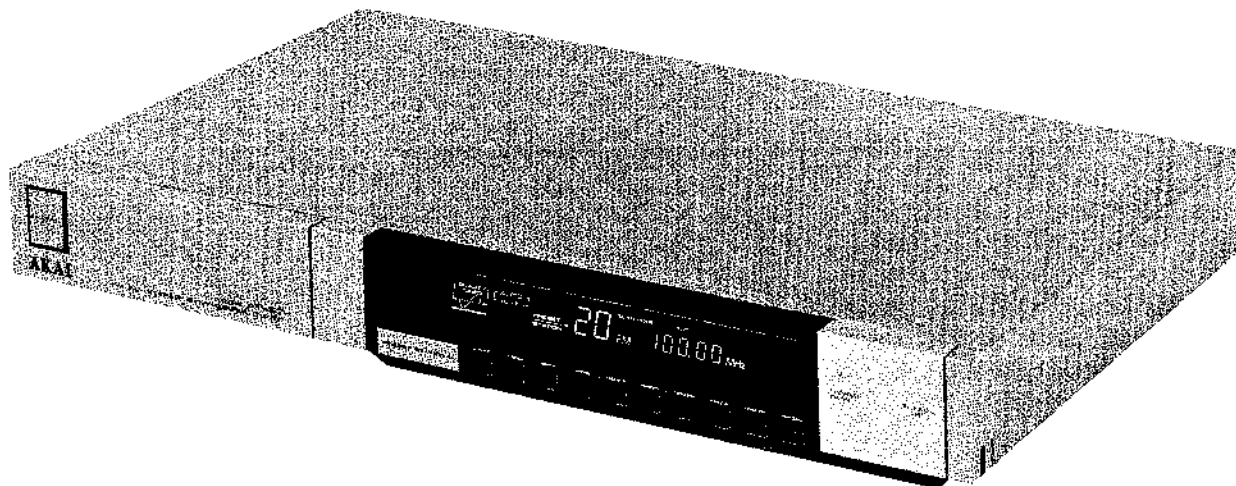

## FM AM STEREO SYNTHESIZER TUNER

### MODEL AT-S7/L

SECTION 1	SERVICE MANUAL .....	3
SECTION 2	PARTS LIST .....	17
SECTION 3	SCHEMATIC DIAGRAM .....	25

# SAFETY INSTRUCTIONS

## SAFETY CHECK AFTER SERVICING

Confirm the specified insulation resistance between power cord plug prongs and externally exposed parts of the set is greater than 10 Mohms, but for equipment with external antenna terminals (tuner, receiver, etc.) and is intended for **C** or **A**, specified insulation resistance should be more than 2.2 Mohms (ground terminals, microphone jacks, headphone jacks, line-in-out jacks etc.)

## PRECAUTIONS DURING SERVICING

1. Parts identified by the  $\Delta$  symbol parts are critical for safety.  
Replace only with parts number specified.
2. In addition to safety, other parts and assemblies are specified for conformance with such regulations as those applying to spurious radiation. These must also be replaced only with specified replacements.  
Examples: RF converters, tuner units, antenna selector switches, RF cables, noise blocking capacitors, noise blocking filters, etc.
3. Use specified internal wiring. Note especially:
  - 1) Wires covered with PVC tubing
  - 2) Double insulated wires
  - 3) High voltage leads
4. Use specified insulating materials for hazardous live parts. Note especially:
  - 1) Insulation Tape
  - 2) PVC tubing
  - 3) Spacers (Insulating Barriers)
  - 4) Insulation sheets for transistors
  - 5) Plastic screws for fixing microswitch (especially in turntable)
5. When replacing AC primary side components (transformers, power cords, noise blocking capacitors, etc.), wrap ends of wires securely about the terminals before soldering.

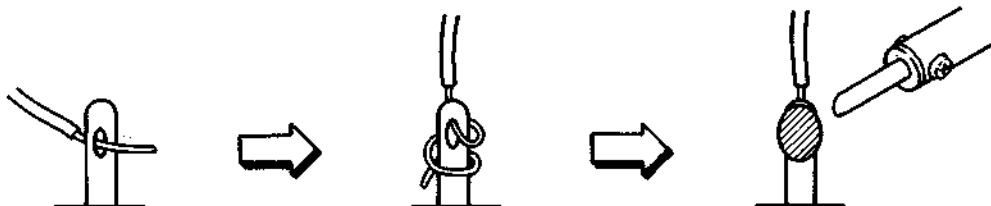

6. Observe that wires do not contact heat producing parts (heatsinks, oxide metal film resistors, fusible resistors, etc.).
7. Check that replaced wires do not contact sharp edged or pointed parts.
8. Also check areas surrounding repaired locations.
9. Use care that foreign objects (screws, solder droplets, etc.) do not remain inside the set.
10. Voltage conversion  
Models for Canada, USA, UK and Australia are not equipped with this facility. Each machine is preset at the factory according to destination. However, if voltage conversion is necessary, it is accomplished as follows:
  - 1) Disconnect the power cord.
  - 2) Set the voltage selector located on the rear panel to the proper position with a screwdriver.

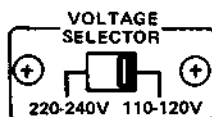

---

SECTION 1

**SERVICE MANUAL**

TABLE CONTENTS

I.	SPECIFICATIONS .....	4
II.	DISMANTLING OF UNIT .....	5
III.	CONTROLS .....	6
IV.	PRINCIPAL PARTS LOCATION .....	7
V.	TUNER ADJUSTMENT .....	8
	5-1 THE INSTRUMENT CONNECTIONS .....	8
	5-2 AT-S7/L TUNER P.C BOARD ADJUSTMENT POINT .....	9
	5-3 AT-S7/L AM (MW, LW) SECTION ADJUSTMENT .....	10
	5-4 AT-S7/L FM SECTION ADJUSTMENT .....	11
VI.	CLASSIFICATION OF VARIOUS P.C BOARDS .....	12
	6-1 P.C BOARD TITLES AND IDENTIFICATION NUMBERS .....	12
	6-2 COMPOSITION OF VARIOUS P.C BOARDS .....	13

For basic adjustments, measuring methods, and operating principles, refer to GENERAL TECHNICAL MANUAL.

# I. SPECIFICATIONS

## FM TUNER SECTION

TUNING FREQUENCY RANGE	87.4 MHz to 108.1 MHz
USABLE SENSITIVITY (IHF)	11.2 dBf
QUIETING SENSITIVITY (S/N = 50 dB) MONO/ST.	16.2/37.2 dBf
CAPTURE RATIO	1.0 dB
SELECTIVITY (400 kHz)	80 dB
IMAGE REJECTION	80 dB
IF REJECTION	110 dB
SPURIOUS REJECTION	100 dB
AM SUPPRESSION	70 dB
SUB CARRIER SUPPRESSION	70 dB
S/N (MONO/ST)	80/75 dB
T.H.D (MONO/ST)	0.03/0.05%
STEREO SEPARATION	53 dB (1 kHz)
FREQUENCY RESPONSE	30 Hz to 15 kHz $\pm$ 0.5 dB

## AM TUNER SECTION

	AM, MW (AT-S7L)	LW (AT-S7L)
TUNING FREQUENCY RANGE	530 to 1,610 kHz (USA & Canada) 522 to 1,611 kHz (Others)	153 to 360 kHz
USABLE SENSITIVITY (LOOP)	300 $\mu$ V/m	800 $\mu$ V/m
SELECTIVITY	25 dB	30 dB
IMAGE REJECTION	40 dB	45 dB
IF REJECTION	55 dB	55 dB
S/N	40 dB	35 dB
T.H.D.	1%	2%
OUTPUT LEVEL	FM (100% MOD.) AM ( 30% MOD.)	700 mV 250 mV
OUTPUT IMPEDANCE	3.3 kohms	
POWER REQUIREMENTS	120V, 60 Hz for USA & Canada 220V, 50 Hz for European countries 240V, 50 Hz for UK & Australia 110–120V/220–240V, 50/60 Hz switchable for other countries.	
POWER CONSUMPTIONS	U Model: 15W C, A Model: 13W	
DIMENSIONS	440(W) $\times$ 53(H) $\times$ 274(D) mm (17.3 $\times$ 2.1 $\times$ 10.8 inches)	
WEIGHT	2.92 kg (6.4 lbs)	

\* For improvement purposes, specifications and design are subject to change without notice.

## II. DISMANTLING OF UNIT

In case of trouble, etc. necessitating dismantling, please dismantle in the order shown in the photographs. Reassemble in reverse order.

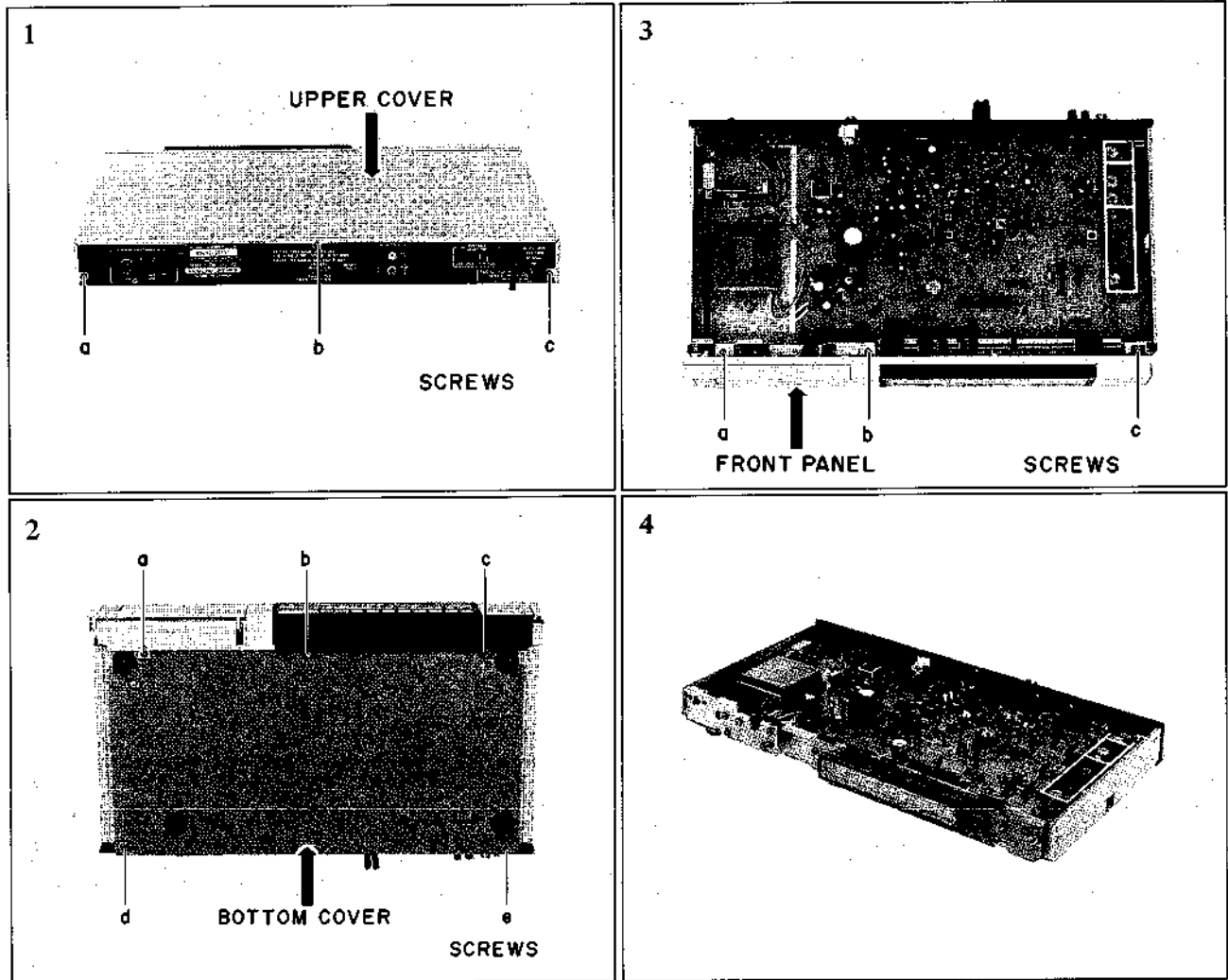

### III. CONTROLS

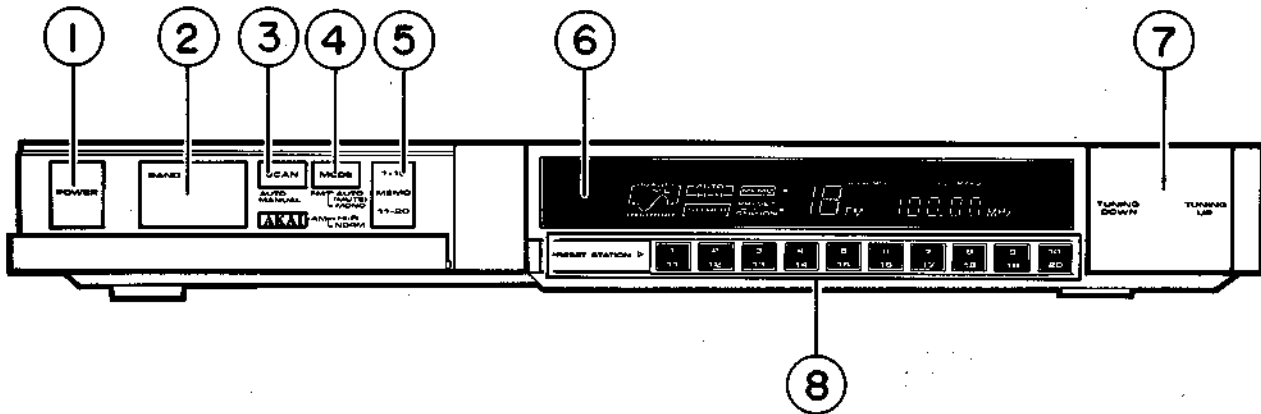

Fig. 3-1

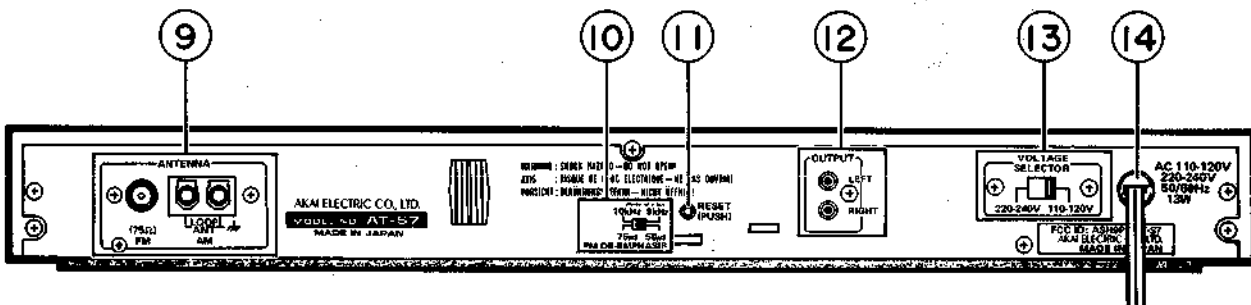

Fig. 3-2

- |                            |  |
|----------------------------|--|
| 1. POWER SWITCH            | 9. ANTENNA TERMINALS   |
| 2. BAND SELECTOR           | 10. AM STEP/FM DE-EMPHASIS SELECTOR SWITCH<br>( <input type="checkbox"/> model only) |
| 3. SCAN MODE SELECTOR      | 11. RESET BUTTON   |
| 4. FM MODE SELECTOR BUTTON | 12. OUTPUT TERMINALS   |
| 5. MEMORY BUTTON           | 13. VOLTAGE SELECTOR SWITCH ( <input type="checkbox"/> model only)                   |
| 6. FL DISPLAY              | 14. POWER CORD   |
| 7. TUNING BUTTON           |  |
| 8. PRESET STATION BUTTONS  |  |



# IV. PRINCIPAL PARTS LOCATION

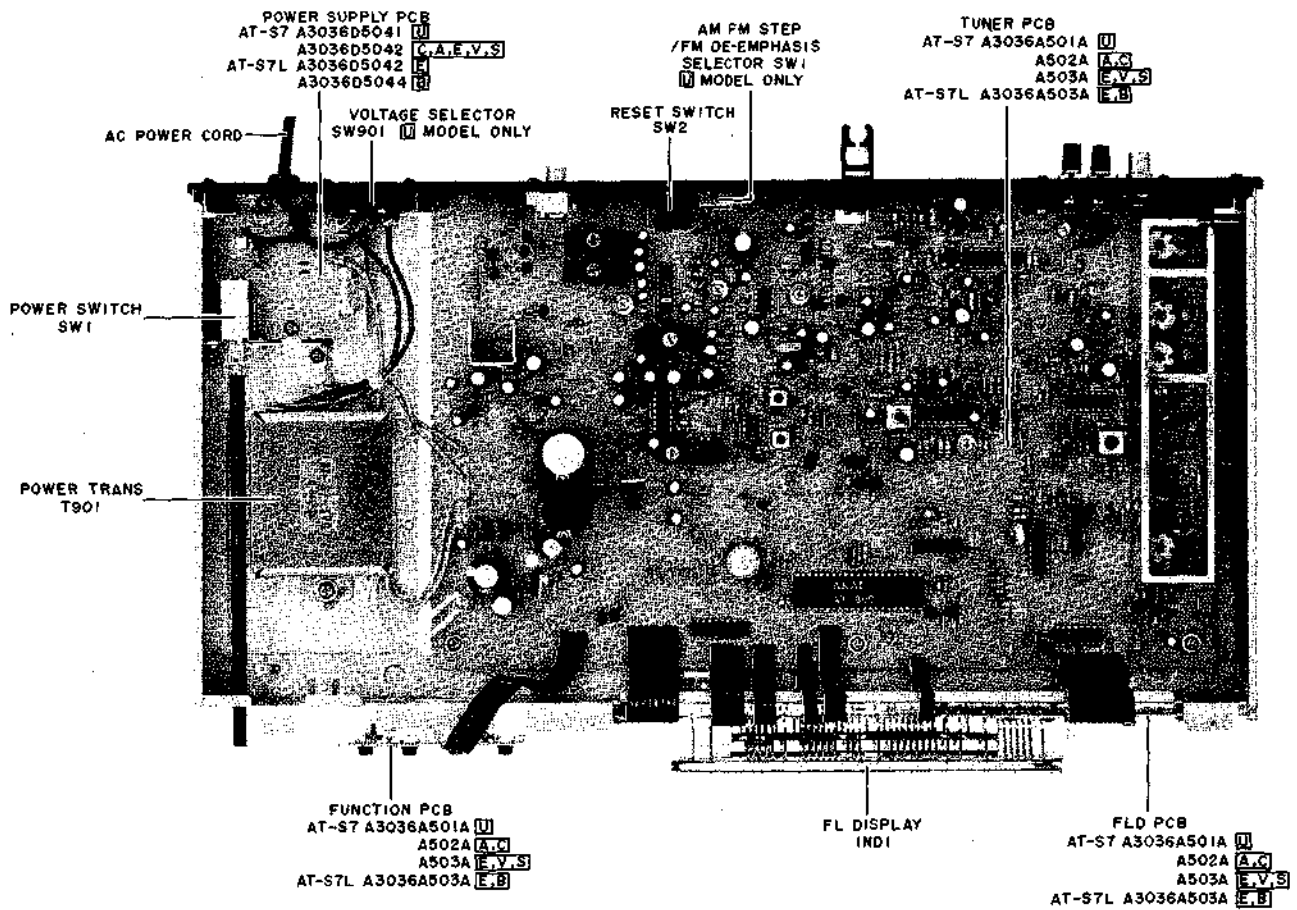

Fig. 4-1 Top View

# V. TUNER ADJUSTMENT

## 5-1 THE INSTRUMENT CONNECTIONS

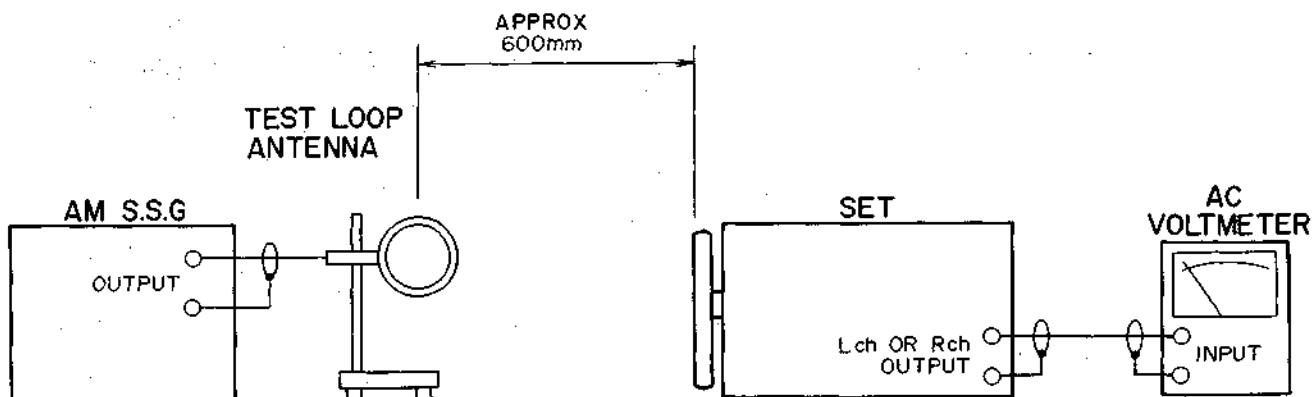

Fig. 5-1 Instrument Connections for AM (MW, LW) Section Adjustment

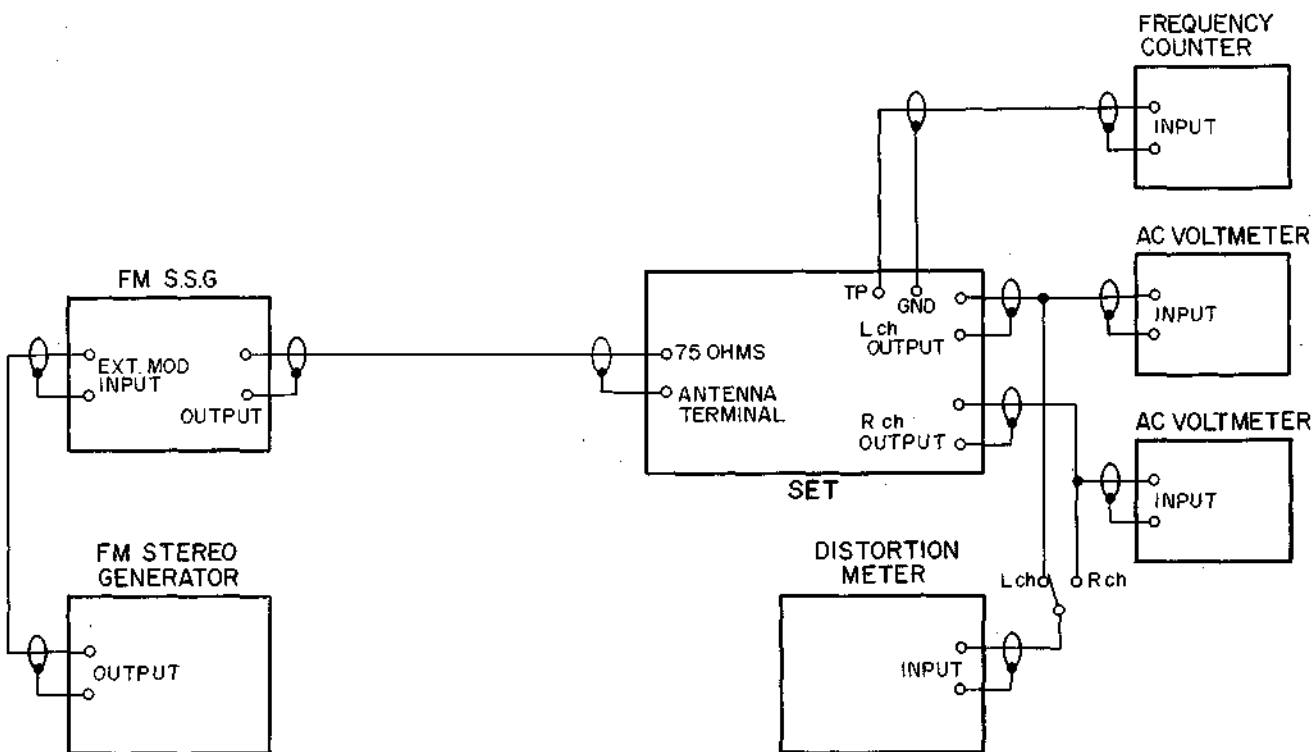

Fig. 5-2 Instrument Connections for FM Section Adjustment

## 5-2 AT-S7/L TUNER P.C BOARD ADJUSTMENT POINTS

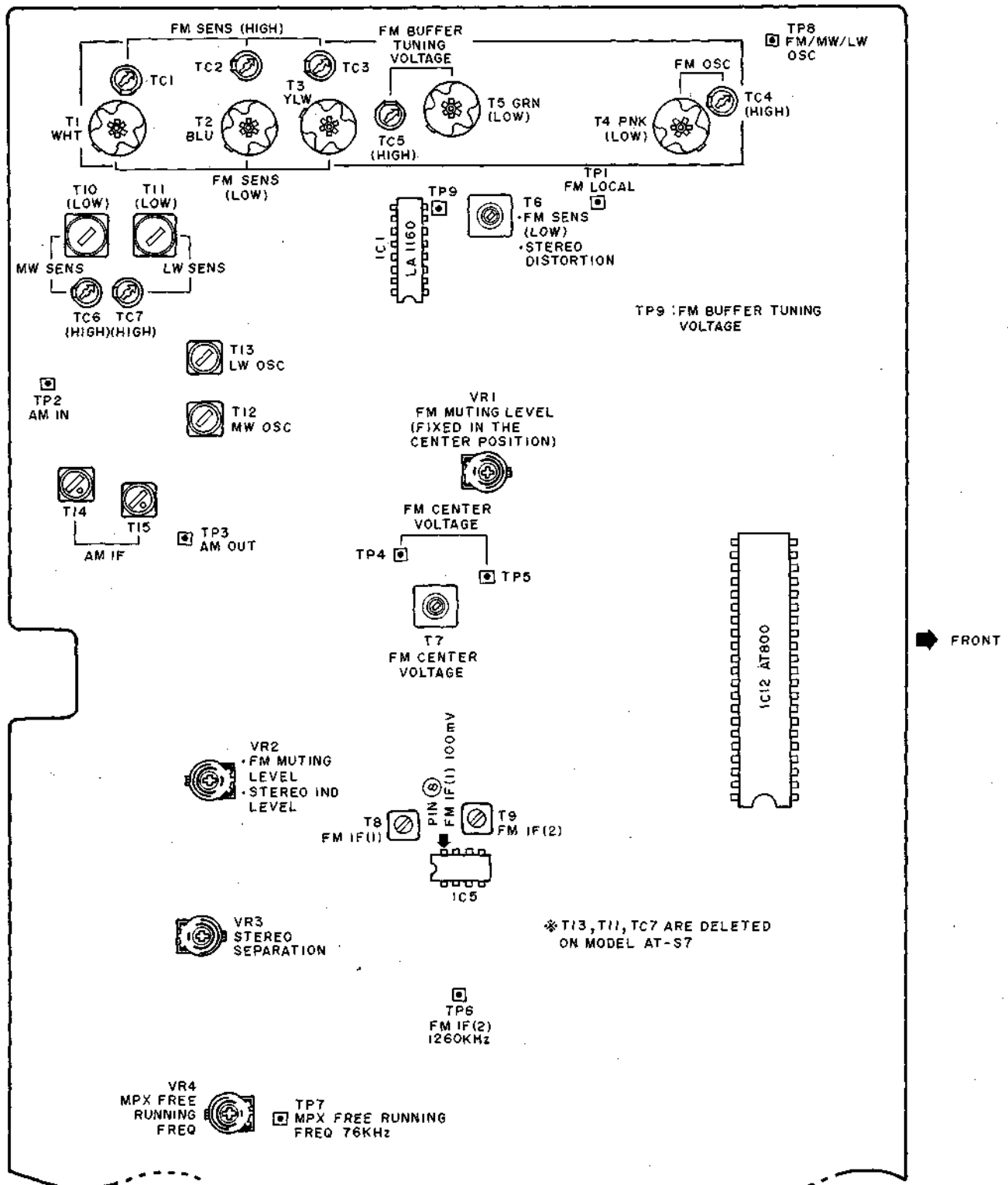

Fig. 5-3

### 5-3 AT-S7/L AM (MW, LW) SECTION ADJUSTMENT (Refer to Figs. 5-1 & 5-3)

Step	Adjustment Item	Adjustment Point	Result	Remarks
1	LW OSC	T13	1.0V at 137 kHz	Band SW to LW. Display to 137 kHz. Voltmeter to TP8.
2	MW OSC	T12	2.0V at 530 kHz (522 kHz)	Band SW to MW. Display to 530 kHz (522 kHz). Voltmeter to TP8.
3	FM OSC (Low)	T4	3.0V at 88 MHz	Band SW to FM. Display to 88 MHz. Voltmeter to TP8.
4	FM OSC (High)	TC4	20.0V at 108 MHz	Display to 108 MHz.
5	Repeat Steps 3 & 4			
6	FM OSC Buffer Tuning Voltage (Low)	T5	Maximum level at 88 MHz	88 MHz, 60 dB, Mono input. Display to 88 MHz. Oscilloscope to TP10.
7	FM OSC Buffer Tuning Voltage (High)	TC5	Maximum level at 108 MHz	108 MHz, 60 dB, Mono input. Display to 108 MHz.
8	Repeat Steps 6 & 7			
9	AM IF	T14, 15	Maximum output Minimum Distortion	Band SW to MW. 1,000 kHz (999 kHz), 90 dB input. Display to 1,000 kHz (999 kHz).
10	LW Low Range Sensitivity	T11	Less than 70 dB	Band SW to LW. 160 kHz input. Less than 10% Distortion Factor. Display to 160 kHz.
11	LW High Range Sensitivity	TC7	Less than 70 dB	300 kHz input. Display to 160 kHz.
12	Repeat steps 10 & 11			
13	Distortion (Confirmation)	None	Less than 5%	200 kHz, 74 dB input. Display to 200 kHz.
14	MW Low Range Sensitivity	T10	Less than 62 dB	Band SW to MW. 600 kHz (603 kHz) input. Display to 600 kHz (603 kHz). Less than 10% Distortion Factor.
15	MW High Range Sensitivity	TC6	Less than 62 dB	1,400 kHz (1,404 kHz) input. Display to 1,400 kHz (1,404 kHz).
16	Repeat steps 14 & 15			
17	Distortion (Confirmation)	None	Less than 2%	1,000 kHz, 74 dB input. Display to 1,000 kHz.
18	Auto Stop (Confirmation)	None	Stop scanning at 1,000 kHz tuned	Scan Mode to AUTO. 1,000 kHz, 74 dB input.

- NOTES:**
1. Set the internal modulation signal generator to 30%, 400 Hz of each.
  2. Use a digital voltmeter for the adjustments in Steps 1 to 5.
  3. Use an Oscilloscope for the adjustments in Steps 6 & 7.
  4. (      kHz) in Result & Remarks indicates the test frequencies in AM 9 kHz STEP area.

## VI. CLASSIFICATION OF VARIOUS P.C BOARDS

### 6-1 P.C BOARD TITLES AND IDENTIFICATION NUMBERS

#### MODEL AT-S7

P.C Board Title		P.C Board Number	Remarks
TUNER	P.C BOARD	A3036A501A	U
TUNER	P.C BOARD	A3036A502A	C, A
TUNER	P.C BOARD	A3036A503A	E, V, S
FUNCTION	P.C BOARD	A3036A501B	U
FUNCTION	P.C BOARD	A3036A502B	C, A
FUNCTION	P.C BOARD	A3036A503B	E, V, S
FLD	P.C BOARD	A3036A501C	U
FLD	P.C BOARD	A3036A502C	C, A
FLD	P.C BOARD	A3036A503C	E, V, S
POWER SUPPLY	P.C BOARD	A3036D5041	U
POWER SUPPLY	P.C BOARD	A3036D5042	C, A, E, V, S

#### MODEL AT-S7L

P.C Board Title		P.C Board Number	Remarks
TUNER	P.C BOARD	A3036A503A	E, B
FUNCTION	P.C BOARD	A3036A503B	E, B
FLD	P.C BOARD	A3036A503C	E, B
POWER SUPPLY	P.C BOARD	A3036D5042	E
POWER SUPPLY	P.C BOARD	A3036D5044	B

#### 5-4 AT-S7/L FM SECTION ADJUSTMENT (Refer to Figs. 5-2 & 5-3)

Step	Adjustment Item	Adjustment Point	Result	Remarks
1	Low Range Sensitivity	T1, 2, 3, 6	Less than 6 dB	Band SW to FM. 88 MHz, Mono input. Display to 88 MHz. 3% Distortion Factor.
2	High Range Sensitivity	TC1, 2, 3	Less than 6 dB	108 MHz. Display to 108 MHz.
3	Repeat Step 1 & 2.			
4	FM Center voltage	T7	0V indication	Voltmeter between TP4 and TP5. Tune only noise without interference from broadcasting.
5	FM IF (1)	T8	Maximum level	98 MHz, 60 dB, Mono input. Oscilloscope to IC5 pin ⑧.
6	FM IF (2)	T9	1,260 kHz	Frequency Counter to TP6.
7	Distortion (Mono) (Confirmation)		Less than 0.1%	98 MHz, 60 dB, Mono input. Display to 98 MHz.
8	FM Muting level	VR2	30 ± 6 dB	98 MHz, Stereo input. Display to 98 MHz.
9	MPX Free Running Frequency	VR4	76 kHz ± 50 Hz	Frequency Counter to TP7
10	Stereo Separation	VR3	More than 45 dB	98 MHz, 60 dB, Stereo L-CH (R-CH) input. Display to 98 MHz. Minimum output of R-CH (L-CH).
11	Distortion (Stereo)	T6	Less than 0.2%	98 MHz, 60 dB, Stereo input. Display to 98 MHz.

- NOTES:**
1. Set the internal modulation signal generator to 100% (75 kHz dev.), 1 kHz of each.
  2. Use a digital voltmeter for the adjustment in step 4.
  3. Use an Oscilloscope for the adjustment in Step 5.
  4. Refer to the AM SECTION ADJUSTMENT Steps 3 to 8 when only the adjustment in FM section is necessary.

6-2 COMPOSITION OF VARIOUS P.C BOARDS

1) AT-S7 TUNER P.C BOARD A3036A501A [U] A3036A502A [A, C], A3036A503A [E, V, S], FUNCTION P.C BOARD A3036A501B [U], A3036A502B [A, C], A3036A503B [E, V, S],  
 FLD P.C BOARD A3036A501C [U], A3036A502C [A, C], A3036A503C [E, V, S]

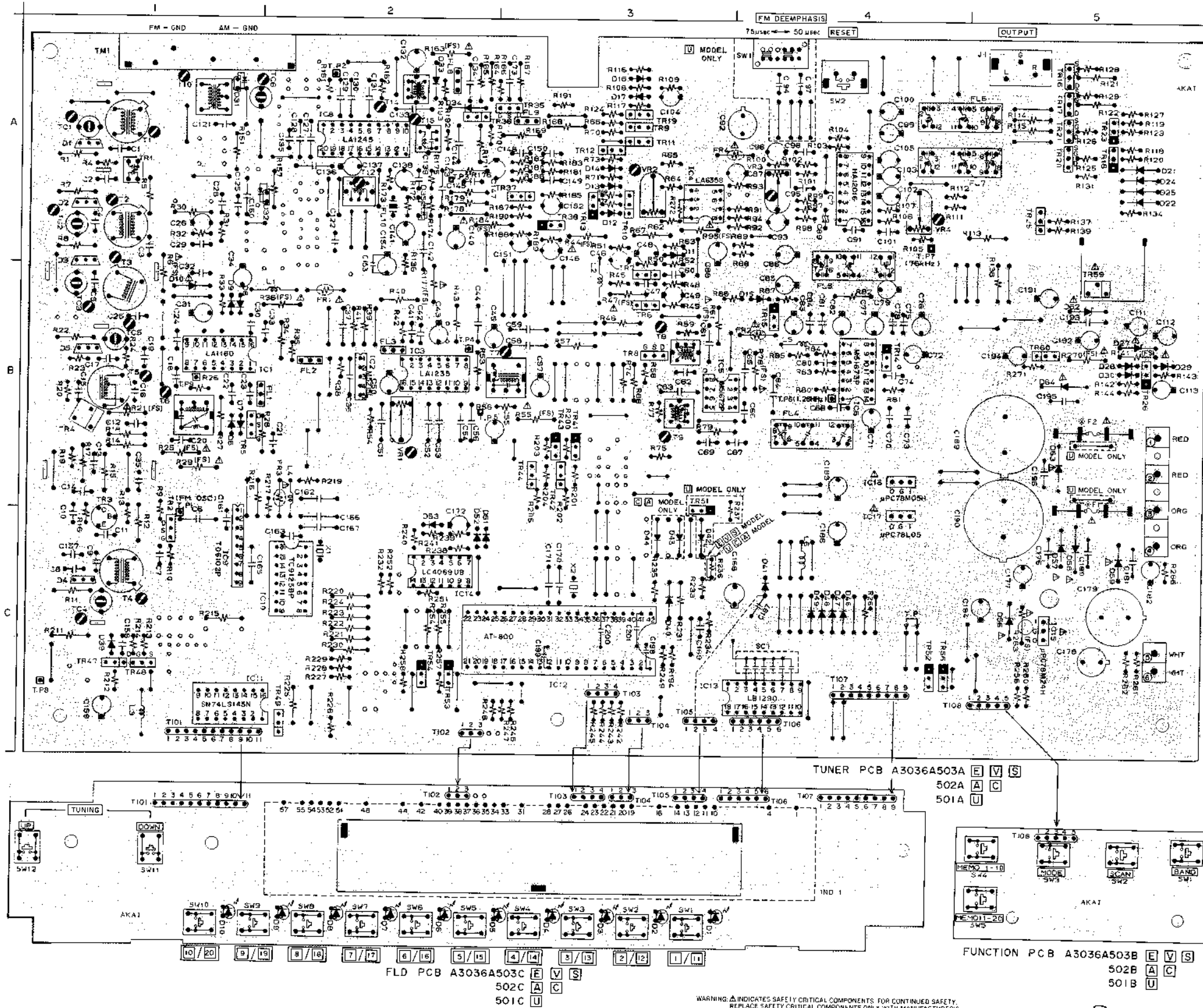

LOCATION OF TR, IC and CONNECTORS

TR	A1	IC	B1	CONNECTOR
TR1	A1	IC1	B1	T101 C1
TR2,3	C1	IC2	B2	T102 C2
TR4,5	B1	IC3	B3	T103 C3
TR6 to 8	B3	IC4	A3	T104 C3
TR9 to 13	A3	IC5	B3	T105 C3
TR14, 15	B4	IC6	B4	T106 C4
TR16 to 18	A5	IC7	A4	T107 C4
TR19	A3	IC8	A2	T108 C5
TR20, 21	A5	IC9	C1	
TR23	A5	IC10	C2	
TR25	A5	IC11	C1	
TR26	B5	IC12	C3	
TR35	A3	IC13	C4	
TR36	A2	IC14	C2	
TR37, 38	A3	IC15	C5	
TR41 to 44	B3	IC16	B4	
TR47, 48	C1	IC17	C4	
TR49	C2			
TR51	B3			
TR52	C4			
TR53, 54	C2			
TR56	C4			
TR59, 60	B3			

TR 1	3SK107 (IC)
TR 2	2SK102 (D, E)
TR 3, 4	2SC930 (E, F)
TR 5, 6, 35	2SK191 (F)
TR 8, 7, 9 to 13, 19, 25, 36, 37, 42, 44, 47, 49, 50	2SC536K-NP (F, G)
TR 14 to 15, 18, 23, 26, 38, 41, 43, 51, 52 to 54, 56	2SA608K-NP (E, F, G)
TR 16, 17, 20, 21	2SK246 (G, F)
TR 48	2SK223 (F)
TR 59	2SD612K (D, E, F)

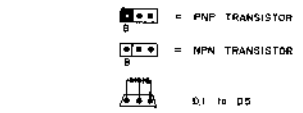

W	U	C.A	E, V, S
F1 Jumper	315mA/25V	T160mA	
F2 Jumper	1.5A/125V	T1.5A	

- ADJUSTMENT POINT
- T1 to 3 FM SENSITIVITY (LOW)
  - T1 to 3 FM SENSITIVITY (HIGH)
  - T4 FM OSC (LOW)
  - T4 FM OSC (HIGH)
  - T5 FM OSC BUFFER TUNING VOLTAGE (LOW)
  - T5 FM OSC BUFFER TUNING VOLTAGE (HIGH)
  - T6 FM SENSITIVITY (LOW) DISTORTION (STEREO)
  - VR1 FM MUTING LEVEL (FIXED IN THE CENTER)
  - T7 FM CENTER VOLTAGE
  - T8 FM IF (1)
  - T9 FM IF (2)
  - VR2 FM MUTING LEVEL
  - VR3 STEREO SEPARATION
  - VR4 MPX FREE RUNNING FREQUENCY 76 KHz
  - T10 MW SENSITIVITY (LOW)
  - T10 MW SENSITIVITY (HIGH)
  - T14 AM IF
  - T12 MW OSC
  - TP1 FM LOCAL
  - TP2 AM IN
  - TP3 AM OUT
  - TP4 FM CENTER VOLTAGE
  - TP5 FM CENTER VOLTAGE
  - TP6 FM IF (2) 1260 KHz
  - TP7 MPX FREE RUNNING FREQUENCY
  - TP8 FM / MW / LW OSC
  - TP9 FM BUFFER TUNING VOLTAGE

I : IN  
 G : GND  
 O : OUT

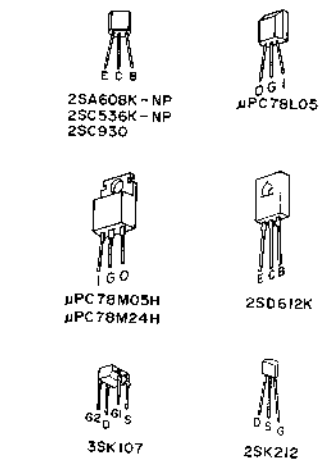

WARNING: Δ INDICATES SAFETY CRITICAL COMPONENTS. FOR CONTINUED SAFETY, REPLACE SAFETY CRITICAL COMPONENTS ONLY WITH MANUFACTURER'S RECOMMENDED PARTS.  
 AVERTISSEMENT: Δ INDIQUE LES COMPOSANTS CRITIQUES DE SÉCURITÉ. POUR MAINTENIR LE DEGRÉ DE SÉCURITÉ DE L'APPAREIL, NE REMPLACER QUE DES PIÈCES RECOMMANDÉES PAR LE FABRICANT.

2) AT-S7L TUNER P.C BOARD A3036A503A [E, B], FUNCTION P.C BOARD A3036A503B [E, B], FLD P.C BOARD A3036A503C [E, B]

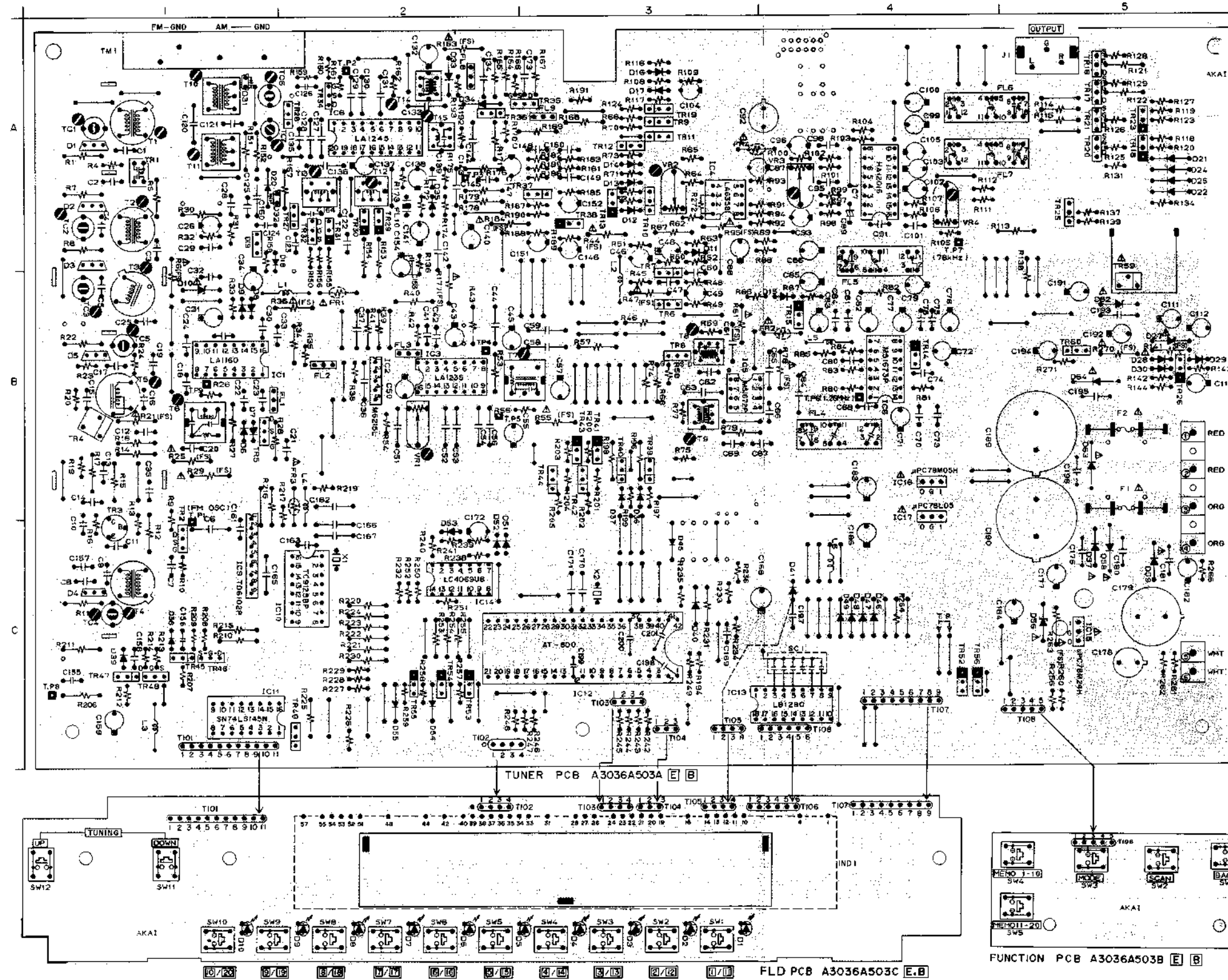

LOCATION of TR IC and CONNECTOR

TR	IC	CONNECTOR
TR 1	A1	IC1 B1
TR 2, 3	C1	IC2 B2
TR 4, 5	B1	IC3 B2
TR 6 to 8	B3	IC4 A3
TR 9 to 13	A3	IC5 B3
TR 14, 15	B4	IC6 B4
TR 16 to 18	A5	IC7 A4
TR 19	A3	IC8 A2
TR 20	A5	IC9 C1
TR 23	A5	IC10 C2
TR 25	A5	IC11 C3
TR 26	B5	IC12 C3
TR 27 to 32	A2	IC13 C4
TR 34	A2	IC14 C2
TR 35	A3	IC15 C5
TR 36	A2	IC16 B4
TR 37, 38	A3	IC17 C4
TR 39 to 44	B3	
TR 45 to 48	C1	
TR 49	C2	
TR 52	C4	
TR 53 to 55	C2	
TR 56	C4	
TR 59, 60	B5	

- TR1 ..... 2SK107 (E)
- TR2 ..... 2SK212 (D, E)
- TR3, 4 ..... 2SK301E (F)
- TR 5, 6, 34, 35 ..... 2SK19 (Y)
- TR 6, 7, 9 to 12, 19, 25, 27, 28, 36, 37, 39, 40, 42) ..... 2SC536K - NP (E, G)
- 44, 45, 47, 49, 60
- TR 13 to 15, 18, 23, 26, 29 to 31, 38, 41, 43, 52 to 56 ..... 2SA608K - NP (E, F, G)
- TR 16, 17, 20, 21, 52 ..... 2SK246 (G, R)
- TR 45 ..... 2SK223 (F)
- TR 59 ..... 2SD612K (D, E, F)

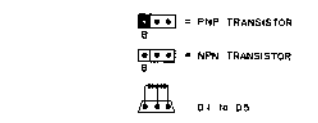

- ADJUSTMENT POINT
- T1 to 3 FM SENSITIVITY (LOW)
  - TC1 to 3 FM SENSITIVITY (HIGH)
  - T4 FM OSC (LOW)
  - TC4 FM OSC (HIGH)
  - T5 FM OSC BUFFER TUNING VOLTAGE (LOW)
  - TC5 FM OSC BUFFER TUNING VOLTAGE (HIGH)
  - T6 FM SENSITIVITY (LOW) DISTORTION (STEREO)
  - TR1 FM MUTING LEVEL (FIXED IN THE CENTER)
  - TR2 FM CENTER VOLTAGE
  - T7 FM IF (1)
  - T9 FM IF (2)
  - VR2 FM MUTING LEVEL
  - VR3 STEREO SEPARATION
  - VR4 MPX PRES RUNNING FREQUENCY 76 kHz
  - TI0 MW SENSITIVITY (LOW)
  - TC6 MW SENSITIVITY (HIGH)
  - TI4, 15 AM IF
  - TI2 MW OSC
  - TI1 LW SENSITIVITY (LOW)
  - TI3 LW OSC
  - TC7 LW SENSITIVITY (HIGH)

- TP1 FM LOCAL  
 TP2 AM IN  
 TP3 AM OUT  
 TP4 FM CENTER VOLTAGE  
 TP5 FM CENTER VOLTAGE  
 TP6 FM IF (2) 1260KHZ  
 TP7 MPX PRES RUNNING FREQUENCY  
 TP8 FM / MW / LW OSC  
 TP9 FM BUFFER TUNING VOLTAGE

- I : IN  
 G : GND  
 O : OUT

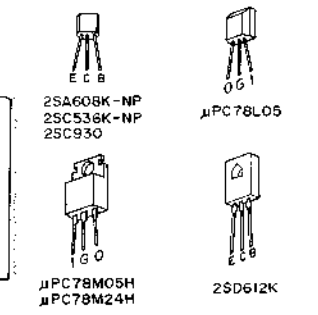

WARNING: Δ INDICATES SAFETY CRITICAL COMPONENTS. FOR CONTINUED SAFETY, REPLACE SAFETY CRITICAL COMPONENTS ONLY WITH MANUFACTURER'S RECOMMENDED PARTS.  
 AVERTISSEMENT: Δ IL INDIQUE LES COMPOSANTS CRITIQUES DE SECURITE POUR MAINTENIR LE DEGRE DE SECURITE DE L'APPAREIL. NE REMPLACER QUE DES PIECES RECOMMANDEES PAR LE FABRICANT.

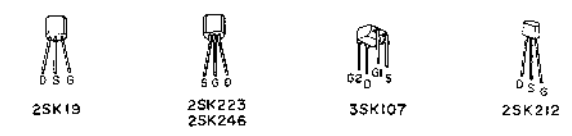



3) POWER SUPPLY P.C BOARD A3036D5041 [U], A3036D5042 [C, A], A3036D5042 [V],  
 A3036D5042 [E, S], A3036D5044 [B]

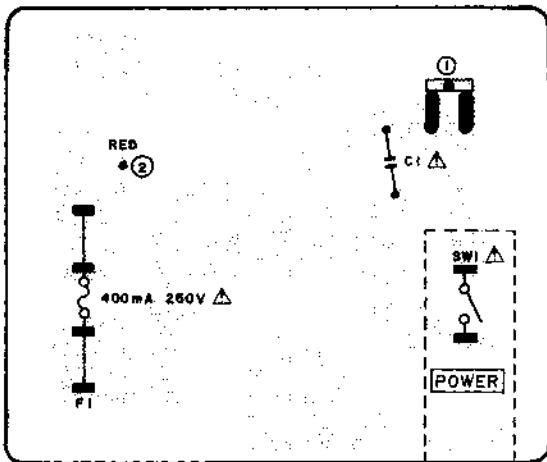

POWER SUPPLY PCB  
 A3036D5041 [U]

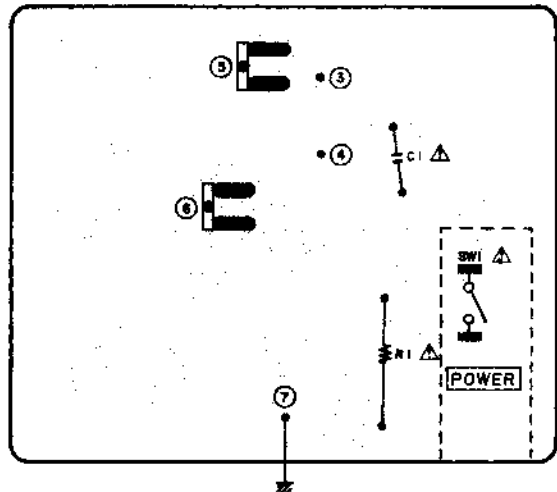

POWER SUPPLY PCB  
 A3036D5042 [C, A]

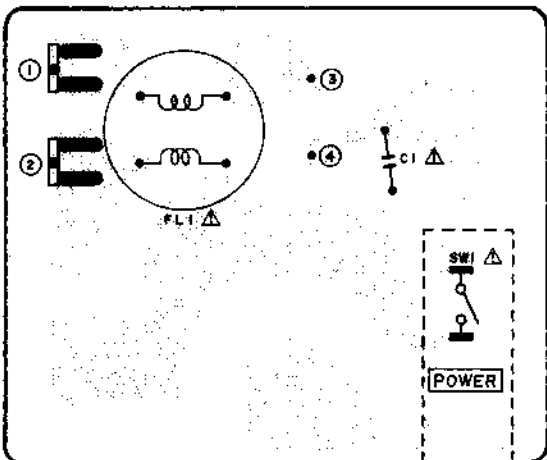

POWER SUPPLY PCB  
 A3036D5042 [V]

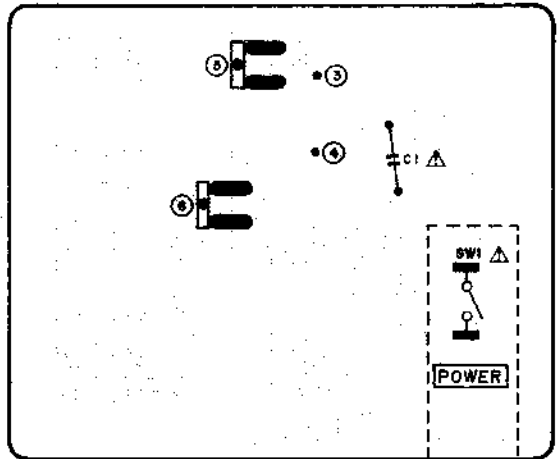

POWER SUPPLY PCB  
 A3036D5042 [E, S]

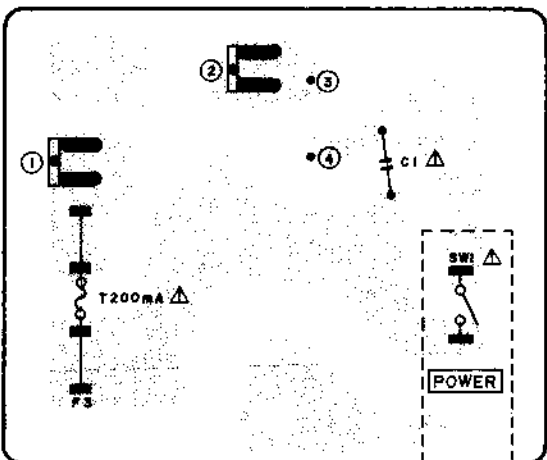

POWER SUPPLY PCB  
 A3036D5044 [B]

WARNING:  $\Delta$  INDICATES SAFETY CRITICAL COMPONENTS FOR CONTINUED SAFETY.  
 REPLACE SAFETY CRITICAL COMPONENTS ONLY WITH MANUFACTURER'S  
 RECOMMENDED PARTS

AVERTISSEMENT:  $\Delta$  ILL INDIQUE LES COMPOSANTS CRITIQUES DE SÉCURITÉ.  
 POUR MAINTENIR LE DEGRÉ DE SÉCURITÉ DE L'APPAREIL,  
 NE REMPLACER QUE DES PIÈCES RECOMMANDÉES PAR LE FABRICANT

---

SECTION 2

**PARTS LIST**

TABLE OF CONTENTS

RECOMMENDED SPARE PARTS .....	19
1. TUNER P.C BOARD BLOCK .....	20
2. POWER SUPPLY P.C BOARD BLOCK .....	21
3. ASSEMBLY BLOCK .....	22
4. FINAL ASSEMBLY BLOCK .....	23
INDEX .....	24

Resistor and Capacitor which is not listed in this parts list, please refer to COMMON LIST FOR SERVICE PARTS.

## ATTENTION

1. When placing an order for parts, be sure to list the parts no., model no., and description. There are instances in which if any of this information is omitted, parts cannot be shipped or the wrong parts will be delivered.
2. Please be careful not to make a mistake in the parts no. If the parts no. is in error, a part different from the one ordered may be delivered.
3. Because parts number and parts unit supply in the Preliminary Parts List may be partially changed, please use this parts list for all future reference.

## HOW TO USE THIS PARTS LIST

1. This Parts List shows the parts that are considered necessary for repairs. Other parts, such as resistors and capacitors, are shown in the "Common List for Service Parts". Select and order such parts from the "Common List for Service Parts".
2. The Recommended Spare Parts shows those parts in the Parts List which are considered particularly important for service.
3. Parts not shown in the Parts List and "Common List for Service Parts" will not be supplied in principle.
4. How to read list
  - a) Mechanism Block
  - b) P.C Board Block

### 2. HEAD BASE BLOCK

REF. NO.	PARTS NO.	DESCRIPTION
2-1x	BH-T2023A320A	HEAD BASE BLOCK GX-F66R
2-2	HP-H2206A010A	HEAD R/P PR4-8FU C
2-3	ZS-477876	PAN20x03STL CMT
2-4	ZS-536488	BID20x08STL CMT
2-5	ZG-402895	CS ANGLE ADJUST SPRING

SP (Service Parts) Classification

A small "x" indicates the inability to show that particular part in the Photo or Illustration.

This number corresponds with the individual parts index number in that figure

This number corresponds with the Figure Number

### 6. SYS. CON. P.C BOARD BLOCK

REF. NO.	PARTS NO.	DESCRIPTION
6-1	BA-T2034A070A	PC SYS CON BLK GX-F44R
6-IC1	EI-324536	IC HD14049BP
6-IC2	EI-336801	IC MB8841-564M
6-IC3	EI-331661	IC SN7405N
6-IC4	EI-336725	IC M54527P
6-TR1to4	ET-200985	TR 2SC2603 F,G
6-TR5to28	ET-554657	TR 2SA733A P,Q
6-D1	ED-318292	D SILICON H 1S2473T-77 T26
6-D2to4	ED-308952	D GERMA V 1K34A-LR F07
6-D5to10	ED-318292	D SILICON H 1S2473T-77 T26
6-X1	EI-318384	OSC X'TAL NC-18C 3.579545MHZ

SP (Service Parts) Classification

This reference numbers corresponds with symbol numbers of Schematic Diagrams.

5. Both the kind of part and installation position can be determined by the Parts Number. To determine where a parts number is listed, utilize Parts Index at end of Parts List. It is necessary first of all to find the Parts Number. This can be accomplished by using the Reference Number listed at right of parts number in the Parts Index.

## WARNING

△ INDICATES SAFETY CRITICAL COMPONENTS. FOR CONTINUED SAFETY, REPLACE SAFETY CRITICAL COMPONENTS ONLY WITH MANUFACTURER'S RECOMMENDED PARTS.

## AVERTISSEMENT

△ IL INDIQUE LES COMPOSANTS CRITIQUES DE SURETE POUR MAINTENIR LE DEGRE DE SECURITE DE L'APPAREIL. NE REMPLACER LES COMPOSANTS DONT LE FONCTIONNEMENT EST CRITIQUE POUR LA SECURITE QUE PAR DES PIECES RECOMMANDEES PAR LE FABRICANT.

## RECOMMENDED SPARE PARTS

Because, if the parts listed below are on hand, almost any repair can be accomplished, we suggest that you stock these Recommended Spare Parts Items.

NO.	PARTS NO.	DESCRIPTION
1	BT-347008	Δ TRANS POWER AT-S7-T30 (C,A)
2	BT-347009	Δ TRANS POWER AT-S7-T40 (E,V)
3	BT-347010	Δ TRANS POWER AT-S7-T50 (S,B)
4	BT-347011	Δ TRANS POWER AT-S7-T70 (U)
5	EC-336865	C S-FIX H CTZ51C 3.0-10
6	EC-337603	C S-FIX H CTZ51F132 5.5-30 (L)
7	EC-346822	COMP C B72C0716-32N
8	EC-347112	FILTER CE AHCFM2-460BL 0.460BMHZ (C)
9	ED-336805	Δ D SILICON DS135D-KB1 200/1.0A
10	ED-346503	Δ D ZENER H HZ20FA F10 2
11	ED-323216	Δ D ZENER H 05Z15 Z
12	ED-337391	D LED GL5NG6 GRN
13	ED-301911	D SILICON H DS448
14	ED-200469	D SILICON H DS448 FA5 F10
15	ED-344280	D SILICON H GMA-01-FY2 F05
16	ED-337575	D SILICON H GMA-01-4-BT T26
17	ED-348205	D SILICON V MC931 DOUBLE
18	ED-336832	D VARACTOR SVC211SP
19	ED-337605	D VARACTOR SVC333 (A) DOUBLE
20	ED-330218	D ZENER H HZ15L 2
21	ED-328700	D ZENER H HZ9 A2
22	EF-336834	Δ FUSE FST3100 T 250V 0.16A (F1) (E,V,B,S)
23	EF-300596	Δ FUSE FST3100 T 250V 0.20A (F3) (L-B)
24	EF-301485	Δ FUSE FST3100 T 250V 1.60A (F2) (E,V,B,S)
25	EF-309389	Δ FUSE TSC A 250V 0.40A (F1) (U)
26	EF-306088	Δ FUSE TSC 125V 0.31A (F1) (C,A)
27	EF-308847	Δ FUSE TSC 125V 1.60A (F2) (C,A)
28	EH-347111	FILTER CE AHCFM2-459BL 0.459MHZ (EXCEPT C)
29	EH-347109	FILTER CE AHCFM2-459EL 0.459MHZ (EXCEPT C)
30	EH-347110	FILTER CE AHCFM2-460EL 0.460MHZ (C)
31	EH-347106	FILTER CE SFE10.7MXKA 10.700MHZ (EXCEPT L)
32	EH-347889	FILTER LC LP BL-34QR
33	EI-310031	Δ IC μPC78L05
34	EI-328798	Δ IC μPC78M05H
35	EI-338675	Δ IC μPC78M24H
36	EI-346964	IC AT-801
37	EI-347119	IC HA12016
38	EI-347114	IC LA1160
39	EI-337417	IC LA1235
40	EI-202218	IC LA1245
41	EI-347116	IC LA6358
42	EI-337013	IC LB1290
43	EI-338171	IC LC4069UB
44	EI-347117	IC M51672P
45	EI-347118	IC M51673P
46	EI-347115	IC M5215L
47	EI-347120	IC SN74LS145N
48	EI-336717	IC TC9125BP
49	EI-315381	IC TD6102P
50	EI-327074	OSC X'TAL HC-18/U 9.000000MHZ
51	EM-347125	IND FL FIP8AM11 CHARACTER
52	EO-330256	OSC CE F85-006 4MHZ
53	ER-319455	Δ R FUSE ERD2FC S10 1/4W 10R0G
54	ER-318248	Δ R FUSE ERD2FC S10 1/4W 47R0G
55	ER-337327	FILTER CE BFU459C4N 0.459MHZ (EXCEPT C)
56	ER-337328	FILTER CE BFU460C4N 0.46MHZ (C)
57	ER-337989	FILTER CE SFE10.7MPKA 10.0MHZ
58	ER-345729	FILTER CE SFE10.7MZ1KA 10.7MHZ (L)
59	ER-336830	FILTER LC LP BL-34HD
60	ER-347107	FILTER LP BL-34QD
61	ES-337902	Δ SW PUSH SDDL1P 01-1 (V)
62	ES-348463	Δ SW SLIDE 00120297 01-2 (U) (SW901)
63	ES-347122	SW SLIDE 00420569 2-04-2S (U)
64	ES-344445	SW TACT EVQ-QHR12B
65	ES-336780	SW TACT KHH10902
66	ET-307193	Δ TR 2SD612K D,E,F
67	ET-323232	TR FET 2SK19 Y
68	ET-337744	TR FET 2SK212 D,E
69	ET-336864	TR FET 2SD223 F
70	ET-337759	TR FET 2SK246 GR
71	ET-337743	TR FET 3SK107 E
72	ET-322778	TR 2SA608K-NP E,F,G
73	ET-316643	TR 2SC536K-NP F,G
74	ET-618873	TR 2SC930 E,F
75	EV-337995	R S-FIX H RVF8P01 3P 103
76	EV-337861	R S-FIX H RVF8P01 3P 302
77	EV-345785	R S-FIX H RVF8P01 3P 504

# 1. TUNER P.C BOARD BLOCK

REF. NO.	PARTS NO.	DESCRIPTION
1-1U	BA-A3036A020A	PC TUNER BLK AT-S7 (U)
1-1C	BA-A3036A020B	PC TUNER BLK AT-S7 (C)(C,A)
1-1E	BA-A3036A020C	PC TUNER BLK AT-S7(E)(E,V,S)
1-1L	BA-A3036A020D	PC TUNER BLK AT-S7L
<b>TUNER P.C BOARD</b>		
1-IC1A	EI-347114	IC LA1160
1-IC2A	EI-347115	IC MS215L
1-IC3A	EI-337417	IC LA1235
1-IC4A	EI-347116	IC LA6358
1-IC5A	EI-347117	IC MS1672P
1-IC6A	EI-347118	IC MS1673P
1-IC7A	EI-347119	IC HA12016
1-IC8A	EI-202218	IC LA1245
1-IC9A	EI-315381	IC TD6102P
1-IC10A	EI-336717	IC TC9125BP
1-IC11A	EI-347120	IC SN74LS145N
1-IC12A	EI-346964	IC AT-801
1-IC13A	EI-337013	IC LB1290
1-IC14A	EI-338171	IC LC4069UB
1-IC15A	EI-338675	Δ IC μPC78M24H
1-IC16A	EI-328798	Δ IC μPC78M05H
1-IC17A	EI-310031	Δ IC μPC78L05
1-TR1A	ET-337743	TR FET 3SK107 E
1-TR2A	ET-337744	TR FET 2SK212 D,E
1-TR3A,4A	ET-618873	TR 2SC930 E,F
1-TR5A	ET-323232	TR FET 2SK19 Y
1-TR6A,7A	ET-316643	TR 2SC536K-NP F,G
1-TR8A	ET-323232	TR FET 2SK19 Y
1-TR9A	ET-316643	TR 2SC536K-NP F,G
1-TR10Ato12A	ET-316643	TR 2SC536K-NP F,G
1-TR13Ato15A	ET-322778	TR 2SA608K-NP E,F,G
1-TR16A,17A	ET-337759	TR FET 2SK246 GR
1-TR18A	ET-322778	TR 2SA608K-NP E,F,G
1-TR19A	ET-316643	TR 2SC536K-NP F,G
1-TR20A,21A	ET-337759	TR FET 2SK246 GR
1-TR23A	ET-322778	TR 2SA608K-NP E,F,G
1-TR25A	ET-316643	TR 2SC536K-NP F,G
1-TR26A	ET-322778	TR 2SA608K-NP E,F,G
1-TR27A,28A	ET-316643	TR 2SC536K-NP F,G (L)
1-TR29Ato31A	ET-322778	TR 2SA608K-NP E,F,G (L)
1-TR33A	ET-337759	TR FET 2SK246 GR (L)
1-TR34A,35A	ET-323232	TR FET 2SK19 Y (L)
1-TR36A,37A	ET-316643	TR 2SC536K-NP F,G
1-TR38A	ET-322778	TR 2SA608K-NP E,F,G
1-TR39A,40A	ET-316643	TR 2SC536K-NP F,G (L)
1-TR41A	ET-322778	TR 2SA608K-NP E,F,G
1-TR42A	ET-316643	TR 2SC536K-NP F,G
1-TR43A	ET-322778	TR 2SA608K-NP E,F,G
1-TR44A,45A	ET-316643	TR 2SC536K-NP F,G
1-TR46A	ET-336864	TR FET 2SK223 F
1-TR47A	ET-316643	TR 2SC536K-NP F,G
1-TR48A	ET-336864	TR FET 2SK223 F
1-TR49A	ET-316643	TR 2SC536K-NP F,G
1-TR51Ato56A	ET-322778	TR 2SA608K-NP E,F,G (U)
1-TR59A	ET-307193	Δ TR 2SD612K D,E,F
1-TR60A	ET-316643	TR 2SC536K-NP F,G
1-D1Ato5A	ED-336832	D VARACTOR SVC211SP
1-D6Ato9A	ED-337575	D SILICON H GMA-01-4-BT T26
1-D10A	ED-328700	D ZENER H HZ9 A2
1-D11Ato17A	ED-337575	D SILICON H GMA-01-4-BT T26
1-D18A	ED-344280	D SILICON H GMA-01-FY2 F05
1-D19A	ED-348205	D SILICON V MC931 DOUBLE
1-D20A	ED-200469	D SILICON H DS448 FA5 F10
1-D21A,22A	ED-301911	D SILICON H DS448
1-D24A,25A	ED-301911	D SILICON H DS448
1-D27A	ED-330218	Δ D ZENER H HZ15L 2
1-D28Ato30A	ED-337575	D SILICON H CMA-01-4-BT T26
1-D31A,32A	ED-337605	D VARACTOR SVC333 (A) DOUBLE
1-D33A,34A	ED-301911	D SILICON H DS448
1-D35A	ED-348205	D SILICON V MC931 DOUBLE
1-D36Ato38A	ED-344280	D SILICON H GMA-01-FY2 F05 (L)

REF. NO.	PARTS NO.	DESCRIPTION
1-D39A	ED-337575	D SILICON H GMA-01-4-BT T26
1-D40A	ED-301911	D SILICON H DS448
1-D41A	ED-337575	D SILICON H GMA-01-4-BT T26
1-D42Ato45A	ED-200469	D SILICON H DS448 FA5 F10
1-D46Ato49A	ED-301911	D SILICON H DS448
1-D51Ato53A	ED-337575	D SILICON H GMA-01-4-BT T26
1-D54A,55A	ED-200469	D SILICON H DS448 FA5 F10(L)
1-D56A	ED-346503	Δ D ZENER H HZ20FA F10 2
1-D57A	ED-301911	Δ D SILICON H DS448
1-D58A	ED-336805	Δ D SILICON DS135D-KB1 200/1.0A
1-D59A	ED-301911	Δ D SILICON H DS448
1-D62A	ED-323216	Δ D ZENER H 05Z15 Z
1-D63A,64A	ED-336805	Δ D SILICON DS135D-KB1 200/1.0A
1-J1A	EJ-337424	PIN J AJC-034-AAB P 2P
1-SW1A	ES-347122	SW SLIDE 00420569 2-04-2S (U)
1-SW2A	ES-344445	SW TACT EVQ-QHR12B
1-VR1A,2A	EV-337995	R S-FIX H RVF8P01 3P 103
1-VR3A	EV-345785	R S-FIX H RVF8P01 3P 504
1-VR4A	EV-337861	R S-FIX H RVF8P01 3P 302
1-L1A	EO-337608	COIL FIX 1 LAL04 2.2μH M
1-L2A	EO-318365	COIL FIX 1 LAL04 1MH K
1-L3A	EO-343807	COIL FIX 1 LAL04 27.00μH K
1-L4A	EO-336934	COIL FIX 1 LAL03KH 2.20μH M
1-L5A	EO-337608	COIL FIX 1 LAL04 2.2μH M
1-L6A	EO-336934	COIL FIX 1 LAL03KH 2.20μH M
1-T1A	EO-347098	COIL VARI 2 E515HNS-200443 RRS9
1-T2A	EO-347099	COIL VARI 2 E515HNS-200572 RFM6
1-T3A	EO-347100	COIL VARI 2 E515HN-110321 RRR4
1-T4A	EO-336871	COIL VARI 2 TFEI-OSC-U
1-T5A	EO-347102	COIL VARI 2 E515HN-110320 RRQ5
1-T6A	EO-348212	COIL IFT EKSC-30174FCU 10.7MHZ
1-T7A	EO-347103	COIL DET 2 78-1078-01
1-T8A	EO-348213	COIL IFT 26-5045-08 10.7MHZ
1-T9A	EO-347104	COIL OSC 2 26-5084-08 9.44MHZ
1-T10A	EO-337598	COIL VARI 2 25A-1353-01
1-T11A	EO-337599	COIL VARI 2 25A-1354-03 (L)
1-T12A	EO-202215	COIL OSC 2 7NR-6721Y 100.0μH
1-T13A	EO-307786	COIL OSC 2 7NR-6722Y 580.0μH (L)
1-T14A	EO-347105	COIL IFT 7LC-4813X
1-T15A	EO-202216	COIL IFT 7MC-6733C 460.0KHZ
1-FL1A	EH-347106	FILTER CE SFE10.7MXKA 10.700MHZ (EXCEPT L)
1-FL1AL	ER-345729	FILTER CE SFE10.7MZ1KA 10.7MHZ (L)
1-FL2A,3A	ER-337989	FILTER CE SFE10.7MPKA 10.7MHZ
1-FL4A	ER-347107	FILTER LP BL-34QD
1-FL5A	ER-336830	FILTER LC LP BL-34HD
1-FL6A,7A	EH-347889	FILTER LC LP BL-34QR
1-FL8A	EH-347109	FILTER CE AHCFM2-459EL 0.459MHZ (EXCEPT C)
1-FL8AC	EH-347110	FILTER CE AHCFM2-460EL 0.460MHZ (C)
1-FL9A	EH-347111	FILTER CE AHCFM2-459BL 0.459MHZ (EXCEPT C)
1-FL9AC	EC-347112	FILTER CE AHCFM2-460BL 0.460MHZ (C)
1-FL10A	ER-337327	FILTER CE BFU459C4N 0.459MHZ (EXCEPT C)
1-FL10AC	ER-337328	FILTER CE BFU460C4N 0.46MHZ (C)
1-X1A	EI-327074	OSC X'TAL HC-18/U 9.000000MHZ
1-X2A	EO-330256	OSC CE F85-006 4MHZ
1-SC1A	EC-346822	COMP C B72C0716-32N
1-TC1Ato6A	EC-336865	C S-FIX H CTZ51C 3.0-10
1-TC7A	EC-337603	C S-FIX H CTZ51F132 5.5-30(L)

REF. NO.	PARTS NO.	DESCRIPTION
1-R6A	ER-322591	△ R CB H S10 FS RDS 1/4W 101J
1-R21A	ER-322591	△ R CB H S10 FS RDS 1/4W 101J
1-R25A	ER-324184	△ R CB H S10 FS RDS 1/4W 121J
1-R29A	ER-322591	△ R CB H S10 FS RDS 1/4W 101J
1-R36A	ER-200939	△ R CB H S10 FS RDS 1/4W 181J
1-R44A	ER-324184	△ R CB H S10 FS RDS 1/4W 121J
1-R47A	ER-322591	△ R CB H S10 FS RDS 1/4W 101J
1-R55A	ER-324184	△ R CB H S10 FS RDS 1/4W 121J
1-R61A	ER-324184	△ R CB H S10 FS RDS 1/4W 121J
1-R78A	ER-324184	△ R CB H S10 FS RDS 1/4W 121J
1-R79A	ER-322591	△ R CB H S10 FS RDS 1/4W 101J
1-R95A	ER-324184	△ R CB H S10 FS RDS 1/4W 121J
1-R141A	ER-324186	△ R CB H S10 FS RDS 1/4W 681J
1-R163A	ER-324185	△ R CB H S10 FS RDS 1/4W 221J
1-R177A	ER-324184	△ R CB H S10 FS RDS 1/4W 121J
1-R184A	ER-324184	△ R CB H S10 FS RDS 1/4W 121J
1-R263A	ER-200940	△ R CB H S10 FS RDS 1/4W 561J
1-R270A	ER-324186	△ R CB H S10 FS RDS 1/4W 681J
1-FR1A,2A	ER-318248	△ R FUSE ERD2FC S10 1/4W 470R0G
1-FR3A	ER-319455	△ R FUSE ERD2FC S10 1/4W 10R0G
1-FR4A	ER-318248	△ R FUSE ERD2FC S10 1/4W 47R0G
1-C89A	EC-300193	C EC V F05 NP SM 100M 16DC
1-C94A	EC-330310	C STY V F05 CQ09S 561J 50DC (U)
1-C95A	EC-334075	C STY V F05 CQ09S 122J 50DC (EXCEPT C)
1-C95AC	EC-334078	C STY V F05 CQ09S 182J 50DC (C)
1-C97A	EC-330310	C STY V F05 CQ09S 561J 50DC (U)
1-C98A	EC-334075	C STY V F05 CQ09S 122J 50DC (EXCEPT C)
1-C98AC	EC-334078	C STY V F05 CQ09S 182J 50DC (C)
1-C101A	EC-327097	C STY V F05 CQ09S 102J 50DC
1-C123A	EC-334065	C STY V F05 CQ09S 161J 50DC (L)
1-C168A	EC-344157	C DOUBLE LAYER 473Z 5.5DC
1-C195A,196A	EC-320548	C CE V F 103Z 250AC
1-TM1A	EJ-344423	TERMINAL W/SCREW YKD31-0133 P 2P

#### FUNCTION P.C BOARD

1-SW1Bto5B ES-336780 SW TACT KHH10902

#### FLD P.C BOARD

1-IND1C EM-347125 IND FL FIP8AM11 CHARACTER  
1-SW1Cto12C ES-336780 SW TACT KHH10902  
1-D1Cto10C ED-337391 D LED GL5NG6 GRN

1-F1U EF-309389 △ FUSE TSC A 250V 0.40A (U)  
1-F1C EF-306088 △ FUSE TSC 125V 0.31A (C,A)  
1-F1E EF-336834 △ FUSE FST3100 T 250V  
0.16A (E,V,B,S)  
1-F2C EF-308847 △ FUSE TSC 125V 1.60A (C,A)

REF. NO.	PARTS NO.	DESCRIPTION
1-F2E	EF-301485	△ FUSE FST3100 T 250V 1.60A (E,V,B,S)
1-F3	EF-300596	△ FUSE FST3100 T 250V 0.20A (L-B)

## 2. POWER SUPPLY P.C BOARD BLOCK

REF. NO.	PARTS NO.	DESCRIPTION
2-SW1	ES-337902	△ SW PUSH SDLD1P 01-1 (V)
2-L1	EO-338409	COIL LF FKOB160MH02 250μH (V)
2-R1	ER-672816	△ R CB H RD 1/2W 225J (C,A)
2-C1U	EC-320548	△ C CE V F 103Z 250AC (U,C,A)
2-C1E	EC-338496	△ C CE V FZ 472P 400AC (E,V,S,B)

# ASSEMBLY BLOCK

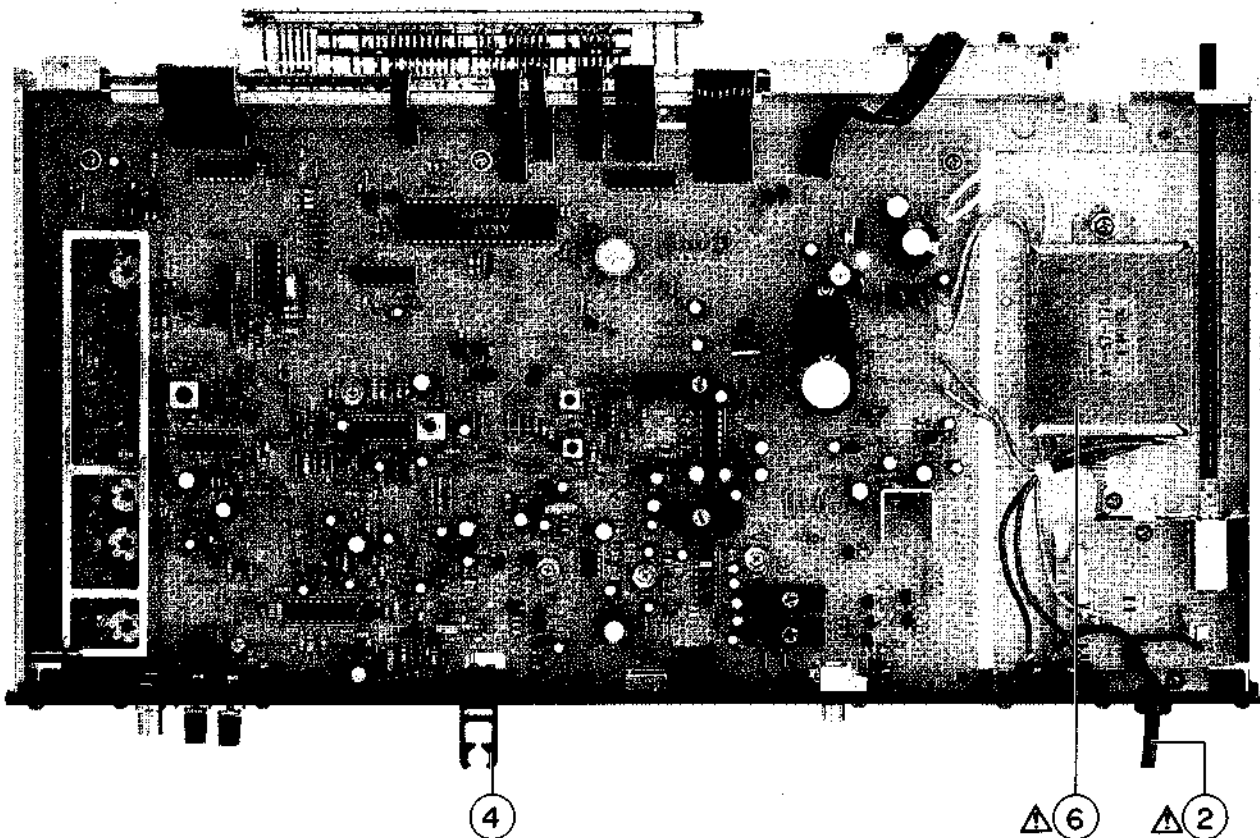
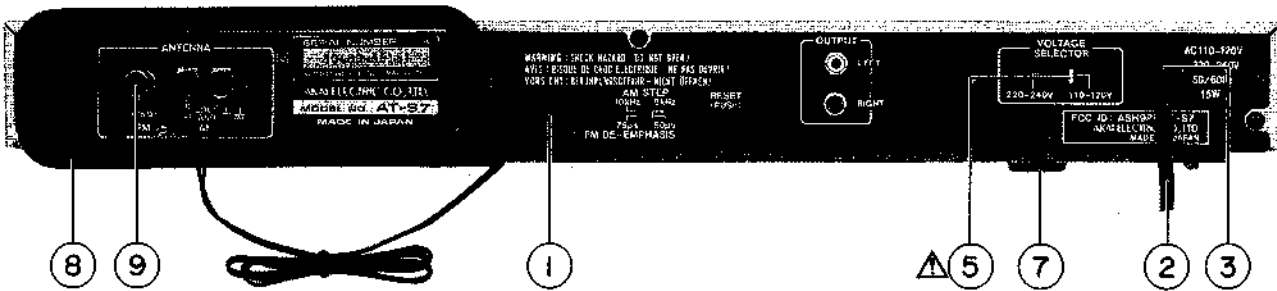

## 3. ASSEMBLY BLOCK

REF. NO.	PARTS NO.	DESCRIPTION	REF. No.	PARTS NO.	DESCRIPTION
3-1U	SP-344780A	PANEL REAR AT-S7 (U)	3-2E	EW-336923	△ AC CORD 2 CORES KP-419C, LTCE-2F EV (E,V)
3-1C	SP-344780B	PANEL REAR AT-S7 (C,A)	3-2S	EW-336924	△ AC CORD 2 CORES KP-560, LTSA-2F S (S)
3-1E	SP-344780D	PANEL REAR AT-S7 (E,V)	3-2B	EW-347025	△ AC CORAD 2 CORES LTBS-2F B (B)
3-1S	SP-344780E	PANEL REAR AT-S7 (S)	3-3	EZ-631945	STRAIN RELIEF SR-4N-4
3-1LE	SP-344780G	PANEL REAR AT-S7L (E)	3-4	SZ-332739	HOLDER ANTENNA
3-1B	SP-344780H	PANEL REAR AT-S7L (B)	3-5	ES-348463	△ SW SLIDE 00120297 01-2
3-2U	EW-306428	△ AC CORD 2 CORES KP-700A, VFF U/T (U)			
3-2C	EW-305691	△ AC CORD 2 CORES KP-8, SPT-1 UC (C,A)			

## FINAL ASSEMBLY BLOCK

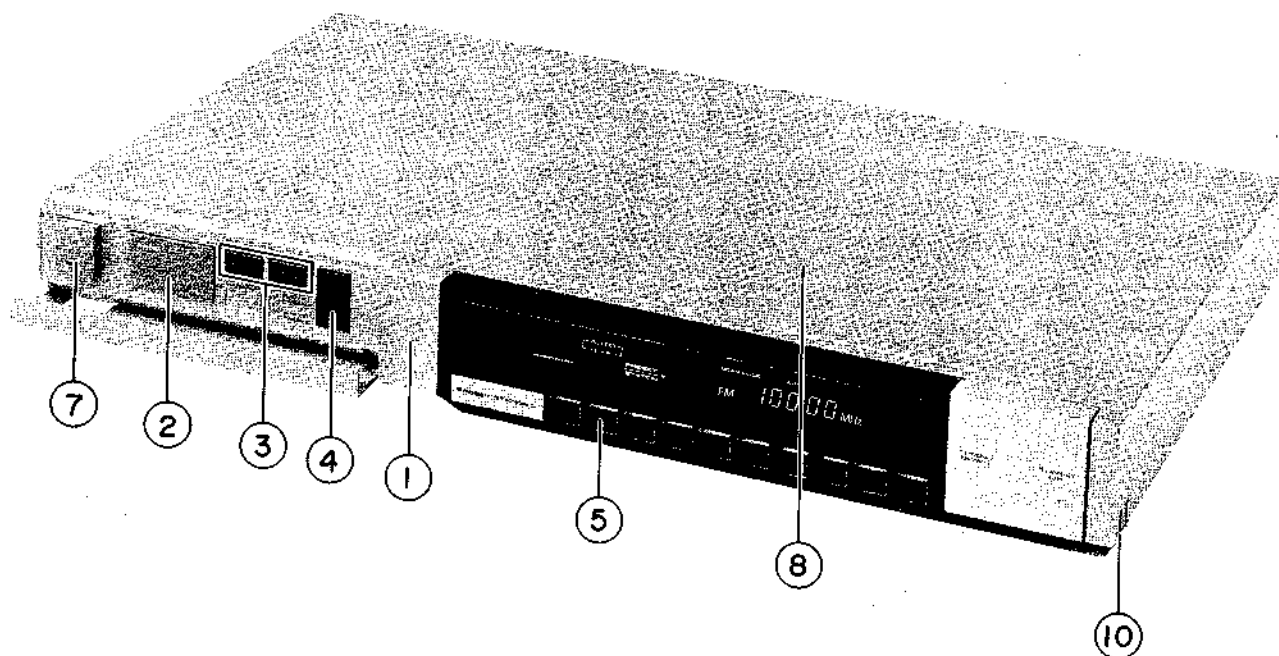

### 4. FINAL ASSEMBLY BLOCK

REF. NO.	PARTS NO.	DESCRIPTION
<b>FRONT PANEL BLOCK</b>		
4-1	BD-A3036A040A	PANEL FRONT BLK AT-S7
4-1P	BD-A3036A040B	PANEL FRONT BLK AT-S7-P
4-1L	BD-A3036A040C	PANEL FRONT BLK AT-S7L
4-1LP	BD-A3036A040D	PANEL FRONT BLK AT-S7L-P
4-2	SK-344787A	KNOB BAND
4-2P	SK-344787B	KNOB BAND-P
4-3	SK-344789A	KNOB PUSH (C)
4-3P	SK-344789B	KNOB PUSH (C)-P
4-4	SK-344791A	KNOB MEMO
4-4P	SK-344791B	KNOB MEMO-P
4-5	SK-B344785	KNOB STATION PART
4-6X	ZG-322189	SP (B)
4-7	SK-342820A	KNOB POWER
4-7P	SK-342820C	KNOB POWER-P (2)
<b>FINAL ASSEMBLY BLOCK</b>		
4-8	SP-344778A	COVER UPPER (A)
4-8P	BC-344778B	COVER UPPER (A)-P
4-9X	ZS-319460	T2BR30x06STL BZN PROJECTION
4-10	AX-344816	IND PLATE
4-11X	AX-344786	IND PLATE MEMORY
4-12XA	AX-344815A	IND PLATE FILM A (U,S)
4-12XB	AX-344815B	IND PLATE FILM B (U,S)
4-12XC	AX-344815C	IND PLATE FILM C (U,S)
4-12XE	AX-344815E	IND PLATE FILM E (A,C,U)
4-12XF	AX-344815F	IND PATE F (E,B,V)
4-12XG	AX-344815G	IND PLATE FILM G (E,B,V)
4-12XD	AX-344815D	IND PLATE FILM D (A,C)

#### SYMBOL FOR COLOR VARIATION

NONE — SILVER  
P — PEARL SHADOW



# INDEX

PARTS NO.	REF. NO.	PARTS NO.	REF. NO.	PARTS NO.	REF. NO.	PARTS NO.	REF. NO.
AX-344786	4-11X	ED-337391	1-D4C	EO-337608	1-L1A	ET-316643	1-TR47A
AX-344815A	4-12XA	ED-337391	1-D10C	EO-338409	2-L1	ET-316643	1-TR45A
AX-344815B	4-12XB	ED-337391	1-D9C	EO-343807	1-L3A	ET-316643	1-TR44A
AX-344815C	4-12XC	ED-337391	1-D6C	EO-347098	1-T1A	ET-316643	1-TR9A
AX-344815D	4-12XD	ED-337391	1-D7C	EO0347099	1-T2A	ET-322778	1-TR55A
AX-344815E	4-12XE	ED-337391	1-D5C	EO-347100	1-T3A	ET-322778	1-TR29A
AX-344815F	4-12XF	ED-337575	1-D12A	EO-347102	1-T5A	ET-322778	1-TR13A
AX-344815G	4-12XG	ED-337575	1-D17A	EO-347103	1-T7A	ET-322778	1-TR53A
AX-344816	4-10	ED-337575	1-D16A	EO-347104	1-T9A	ET-322778	1-TR41A
BA-A3036A020A	1-1U	ED-337575	1-D28A	EO-347105	1-T14A	ET-322778	1-TR38A
BA-A3036A020B	1-1C	ED-337575	1-D6A	EO-348212	1-T6A	ET-322778	1-TR15A
BA-A3036A020C	1-1E	ED-337575	1-D7A	EO-348213	1-T8A	ET-322778	1-TR14A
BA-A3036A020D	1-1L	ED-337575	1-D9A	ER-200939	1-R36A	ET-322778	1-TR43A
BC-344778B	4-8P	ED-337575	1-D11A	ER-200940	1-R263A	ET-322778	1-TR26A
BD-A3036A040A	4-1	ED-337575	1-D13A	ER-318248	1-FR4A	ET-322778	1-TR30A
BD-A3036A040B	4-1P	ED-337575	1-D14A	ER-318248	1-FR1A	ET-322778	1-TR23A
BD-A3036A040C	4-1L	ED-337575	1-D15A	ER-318248	1-FR2A	ET-322778	1-TR18A
BD-A3036A040D	4-1LP	ED-337575	1-D30A	ER-319455	1-FR3A	ET-322778	1-TR51A
BT-347008	3-6C	ED-337575	1-D29A	ER-322591	1-R79A	ET-322778	1-TR31A
BT-347009	3-6E	ED-337575	1-D39A	ER-322591	1-R21A	ET-322778	1-TR56A
BT-347010	3-6S	ED-337575	1-D41A	ER-322591	1-R47A	ET-322778	1-TR54A
BT-347011	3-6U	ED-337575	1-D52A	ER-322591	1-R29A	ET-322778	1-TR52A
EC-300193	1-C89A	ED-337575	1-D8A	ER-322591	1-R6A	ET-323232	1-TR35A
EC-320548	1-C195A	ED-337575	1-D53A	ER-324184	1-R55A	ET-323232	1-TR8A
EC-320548	1-C196A	ED-337575	1-D51A	ER-324184	1-R78A	ET-323232	1-TR5A
EC-320548	2-C1U	ED-337605	1-D32A	ER-324184	1-R61A	ET-323232	1-TR34A
EC-327097	1-C101A	ED-337605	1-D31A	ER-324184	1-R184A	ET-336864	1-TR48A
EC-330310	1-C97A	ED-344280	1-D18A	ER-324184	1-R177A	ET-336864	1-TR46A
EC-330310	1-C94A	ED-344280	1-D38A	ER-324184	1-R44A	ET-337743	1-TR1A
EC-334065	1-C123A	ED-344280	1-D36A	ER-324184	1-R95A	ET-337744	1-TR2A
EC-334075	1-C95A	ED-344280	1-D37A	ER-324184	1-R25A	ET-337759	1-TR16A
EC-334075	1-C98A	ED-346503	1-D56A	ER-324185	1-R163A	ET-337759	1-TR20A
EC-334078	1-C95AC	ED-348205	1-D35A	ER-324186	1-R141A	ET-337759	1-TR33A
EC-334078	1-C98AC	ED-348205	1-D19A	ER-324186	1-R270A	ET-337759	1-TR17A
EC-336865	1-TC3A	EE-337976	3-8	ER-336830	1-FL5A	ET-337759	1-TR21A
EC-336865	1-TC2A	EF-300596	1-F3	ER-337327	1-FL10A	ET-618873	1-TR4A
EC-336865	1-TC1A	EF-301485	1-F2E	ER-337328	1-FL10AC	ET-618873	1-TR3A
EC-336865	1-TC5A	EF-306088	1-F1C	ER-337989	1-FL3A	EV-337861	1-VR4A
EC-336865	1-TC6A	EF-308847	1-F2C	ER-337989	1-FL2A	EV-337995	1-VR1A
EC-336865	1-TC4A	EF-309389	1-F1U	ER-345729	1-FL1AL	EV-337995	1-VR2A
EC-337603	1-TC7A	EF-336834	1-F1E	ER-347107	1-FL4A	EV-345785	1-VR3A
EC-338496	2-C1E	EH-347106	1-FL1A	ER-672816	2-R1	EW-305691	3-2C
EC-344157	1-C168A	EH-347109	1-FL8A	ES-336780	1-SW1C	EW-306428	3-2U
EC-346822	1-SC1A	EH-347110	1-FL8AC	ES-336780	1-SW12C	EW-336923	3-2E
EC-347112	1-FL9AC	EH-347111	1-FL9A	ES-336780	1-SW3C	EW-336924	3-2S
ED-200469	1-D20A	EH-347889	1-FL7A	ES-336780	1-SW8C	EW-347025	3-2B
ED-200469	1-D42A	EH-347889	1-FL6A	ES-336780	1-SW4C	EZ-631945	3-3
ED-200469	1-D43A	EI-202218	1-IC8A	ES-336780	1-SW11C	SA-202118	3-7
ED-200469	1-D44A	EI-310031	1-IC17A	ES-336780	1-SW6C	SK-B344785	4-5
ED-200469	1-D45A	EI-315381	1-IC9A	ES-336780	1-SW5C	SK-342820A	4-7
ED-200469	1-D54A	EI-327074	1-X1A	ES-336780	1-SW9C	SK-342820C	4-7P
ED-200469	1-D55A	EI-328798	1-IC16A	ES-336780	1-SW4B	SK-344787A	4-2
ED-301911	1-D25A	EI-336717	1-IC10A	ES-336780	1-SW1B	SK-344787B	4-2P
ED-301911	1-D21A	EI-337013	1-IC13A	ES-336780	1-SW2C	SK-344789A	4-3
ED-301911	1-D22A	EI-337417	1-IC3A	ES-336780	1-SW10C	SK-344789B	4-3P
ED-301911	1-D24A	EI-338171	1-IC14A	ES-336780	1-SW5B	SK-344791A	4-4
ED-301911	1-D33A	EI-338675	1-IC15A	ES-336780	1-SW3B	SK-344791B	4-4P
ED-301911	1-D34A	EI-346964	1-IC12A	ES-336780	1-SW2B	SP-344778A	4-8
ED-301911	1-D48A	EI-347114	1-IC1A	ES-336780	1-SW7C	SP-344780A	3-1U
ED-301911	1-D49A	EI-347115	1-IC2A	ES-337902	2-SW1	SP-344780B	3-1C
ED-301911	1-D40A	EI-347116	1-IC4A	ES-344445	1-SW2A	SP-344780D	3-1E
ED-301911	1-D47A	EI-347117	1-IC5A	ES-347122	1-SW1A	SP-344780E	3-1S
ED-301911	1-D57A	EI-347118	1-IC6A	ES-348463	3-5	SP-344780G	3-1LE
ED-301911	1-D46A	EI-347119	1-IC7A	ET-307193	1-TR59A	SP-344780H	3-1B
ED-301911	1-D59A	EI-347120	1-IC11A	ET-316643	1-TR12A	SZ-332739	3-4
ED-323216	1-D62A	EJ-315331	3-9	ET-316643	1-TR40A	ZG-322189	4-6X
ED-328700	1-D10A	EJ-337424	1-J1A	ET-316643	1-TR19A	ZS-319460	4-9X
ED-330218	1-D27A	EJ-344423	1-TM1A	ET-316643	1-TR11A	ZW-305013	3-10X
ED-336805	1-D64A	EM-347125	1-IND1C	ET-316643	1-TR39A		
ED-336805	1-D63A	EO-202215	1-T12A	ET-316643	1-TR42A		
ED-336805	1-D58A	EO-202216	1-T15A	ET-316643	1-TR60A		
ED-336832	1-D1A	EO-307786	1-T13A	ET-316643	1-TR28A		
ED-336832	1-D2A	EO-318365	1-L2A	ET-316643	1-TR49A		
ED-336832	1-D3A	EO-330256	1-X2A	ET-316643	1-TR37A		
ED-336832	1-D5A	EO-336871	1-T4A	ET-316643	1-TR36A		
ED-336832	1-D4A	EO-336934	1-L4A	ET-316643	1-TR27A		
ED-337391	1-D8C	EO-336934	1-L6A	ET-316643	1-TR25A		
ED-337391	1-D1C	EO-337598	1-T10A	ET-316643	1-TR7A		
ED-337391	1-D2C	EO-337599	1-T11A	ET-316643	1-TR6A		
ED-337391	1-D3C	EO-337608	1-L5A	ET-316643	1-TR10A		

---

SECTION 3

**SCHEMATIC DIAGRAM**

TABLE OF CONTENTS

1. SCHEMATIC DIAGRAM OF ICs .....	26
2. AT-S7/L BLOCK DIAGRAM .....	31
3. AT-S7 SCHEMATIC DIAGRAM .....	32
4. AT-S7L SCHEMATIC DIAGRAM .....	33

AT800, AT801

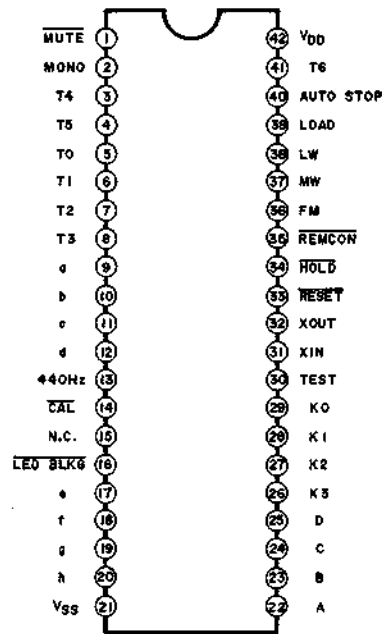

TERMINAL DESCRIPTION OF IC AT800, AT801

Pin No.	Name	Description
1	MUTE	Muting output at "L"
2	MONO	Mono output at "H"
3	T4	} FLD Digit & Key Matrix Digit output
4	T5	
5	T0	
6	T1	
7	T2	
8	T3	
9	a	} 7 Segment Drive
10	b	
11	c	
12	d	
13	440Hz	440Hz Pulse output
14	CAL	
15	N.C.	Not used
16	LED BLKG	CH No. LEDs Blanking signal output
17	e	} 7 Segment Drive
18	f	
19	g	
20	h	FLD Mode Segment Data output
21	Vss	Connected to ground
22	A	} PLL Data & CH No. LED output
23	B	
24	C	
25	D	

Pin No.	Name	Description
26	K3	} Key Matrix Data input
27	K2	
28	K1	
29	K0	
30	TEST	Connected to ground
31	X IN	Crystal OSC terminal
32	X OUT	Crystal OSC terminal
33	$\overline{\text{RESET}}$	RESET at "L", when the power is turned on
34	$\overline{\text{HOLD}}$	Back-up Detection, Back-up at "L"
35	$\overline{\text{REMCON}}$	Remote Control Pulse input
36	FM	FM Band output, FM at "H"
37	MW	MW Band output, MW at "H"
38	LW	LW Band output, LW at "H"
39	LOAD	PLL Data Latch Signal output
40	AUTO STOP	Auto Stop at "H"
41	T6	Key Matrix Digit output
42	VDD	+5V

LA6358

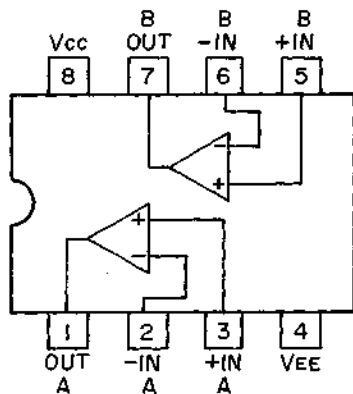

LC4069UB

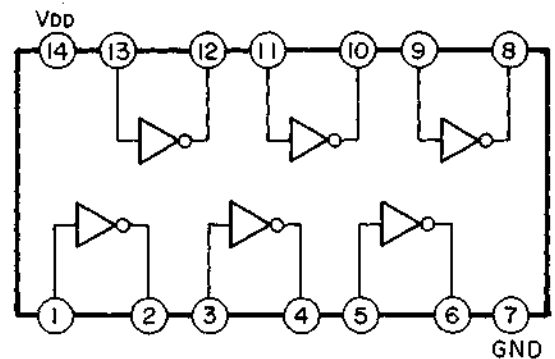

**HA12016**

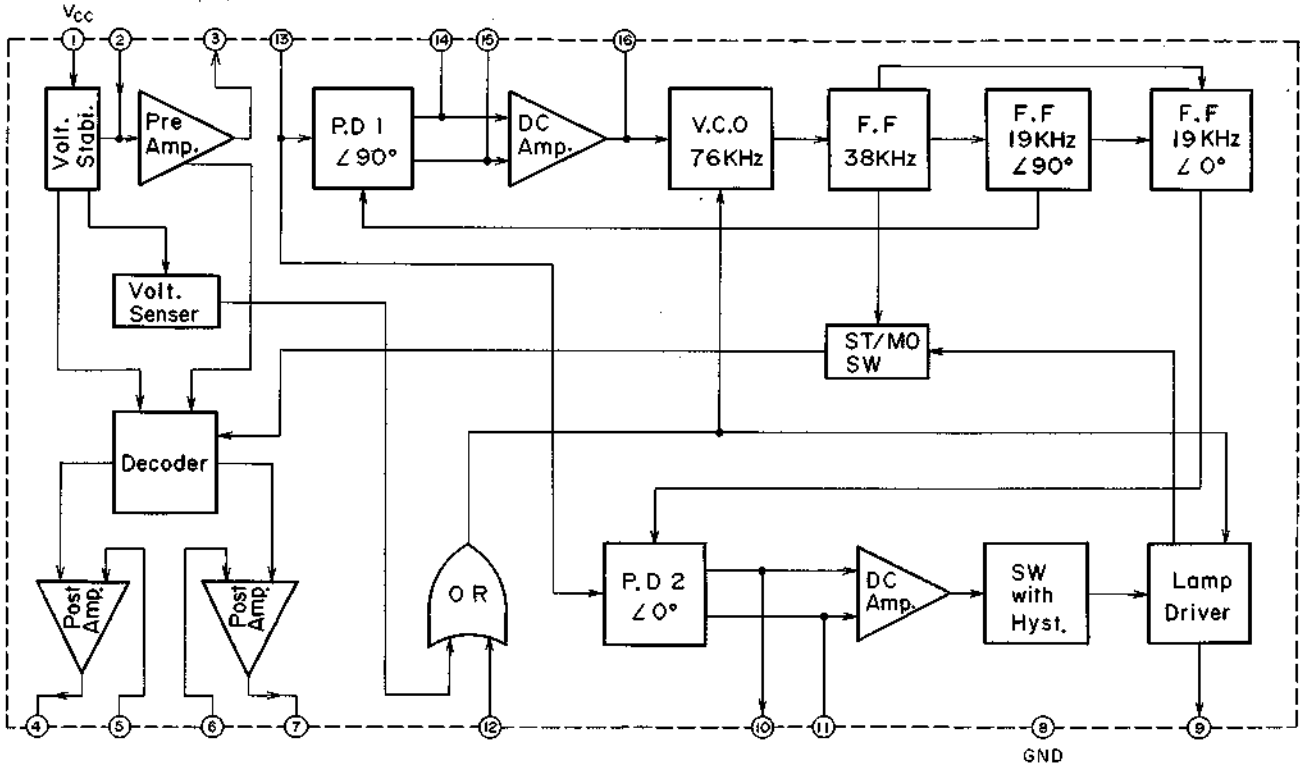

**M5215L**

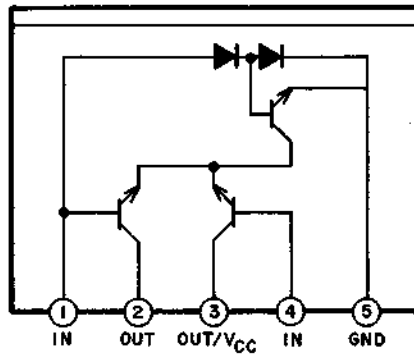

**SN74LS145**

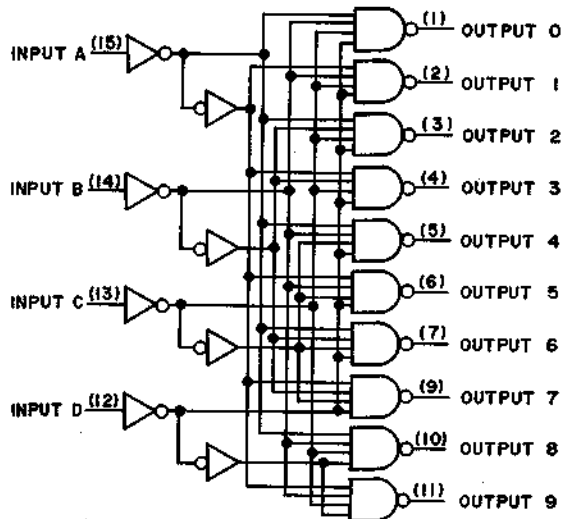
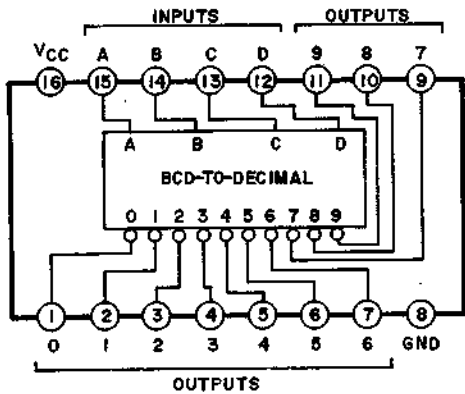

TC9125BP

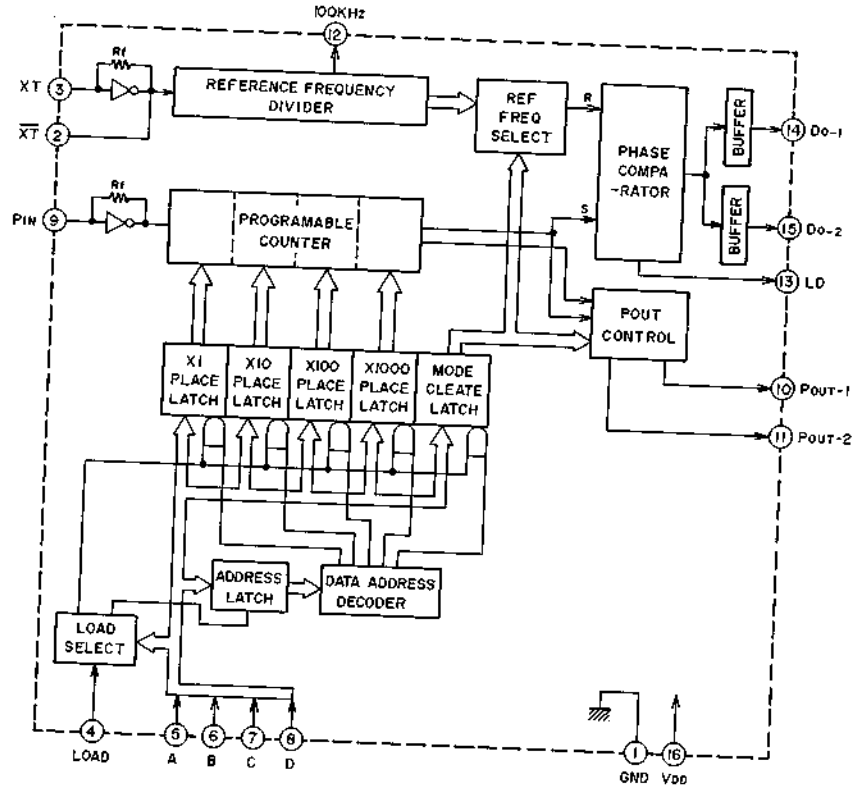
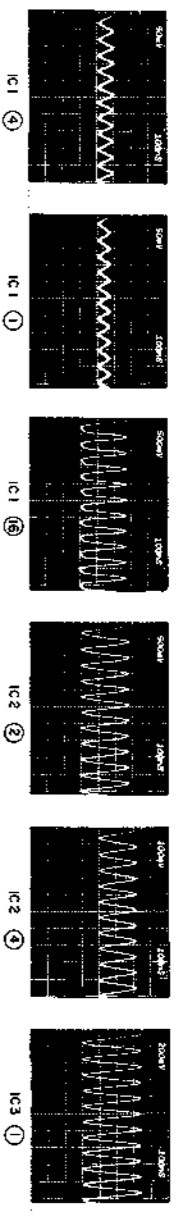
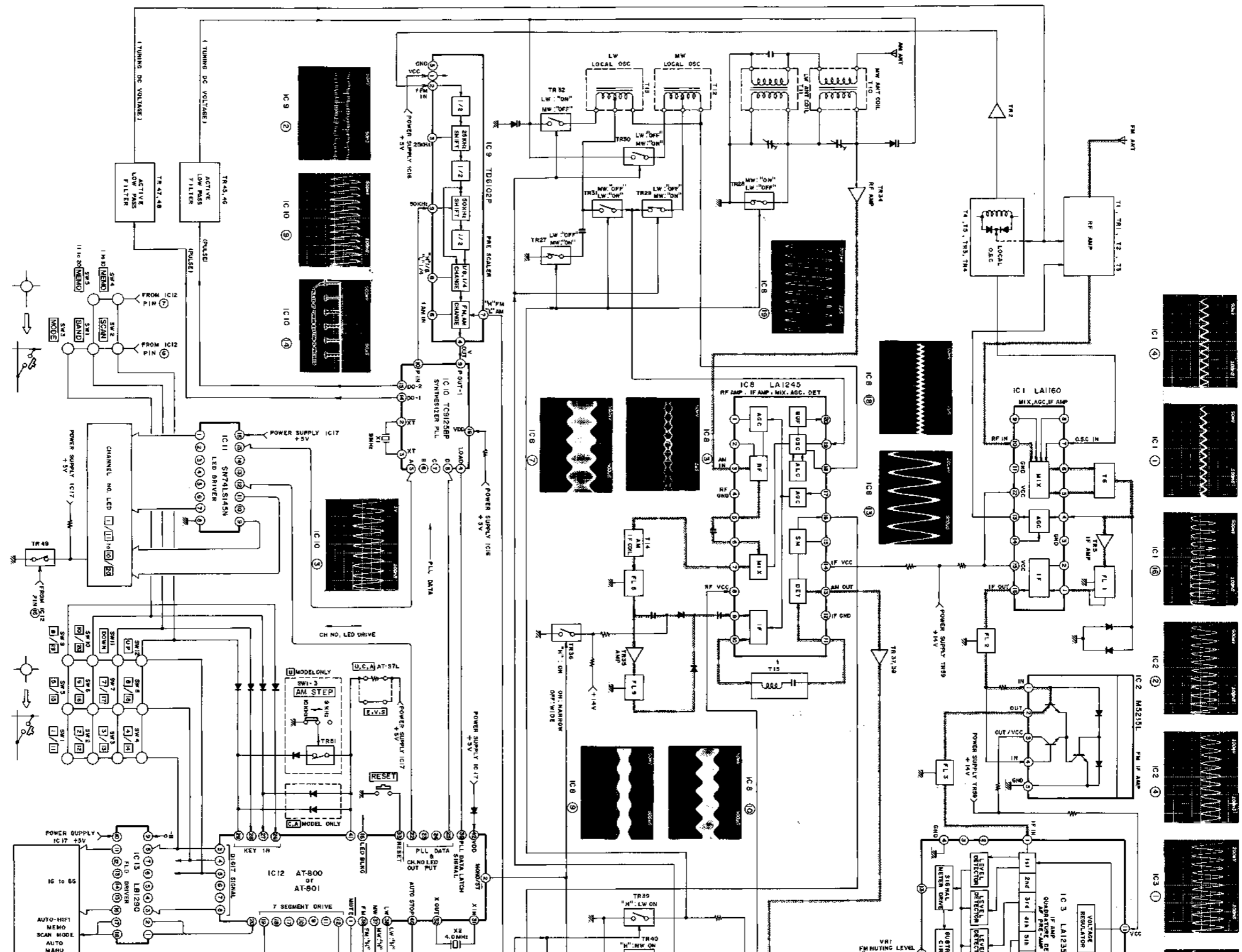

CHART FOR TC9125BP

Pin No.	Symbol	Designation of terminal	Description of functions and operations
1	GND	Earth terminal	
2	XT	Crystal oscillator connection terminal	Connection of 9.0 MHz crystal oscillator.
3	XT		
4	LOAD	Load input terminal	Data reading instruction input terminal for A, B, C and D. Data is read when this terminal is at "H" level, but when at "L" level, the previous data is held regardless of other inputs.
5	A	Program/data input terminals	Input terminal for reference frequency selection data and programmable counter division digit data.
6	B		
7	C		
8	D		
9	PIN	Programmable counter input terminal	
10	POUT-1	Programmable counter output terminal	To be connected to the prescaler TD6102P for fine adjustment of IF frequency in FM or for 50 kHz shift in Europe. The signal of Pout-1 and Pout-2 is output at the point of different phase.
11	POUT-2		
12	100 kHz	100 kHz clock output terminal	
13	LD	Lock-out detection terminal	"H" level when lock-out occurs.
14	Do-1	Phase comparator output terminal	To be connected to low-pass filter.
15	Do-2		
16	VDD	Power terminal	+5V



A B C D E F 1 2 3 4 5 6 7 8





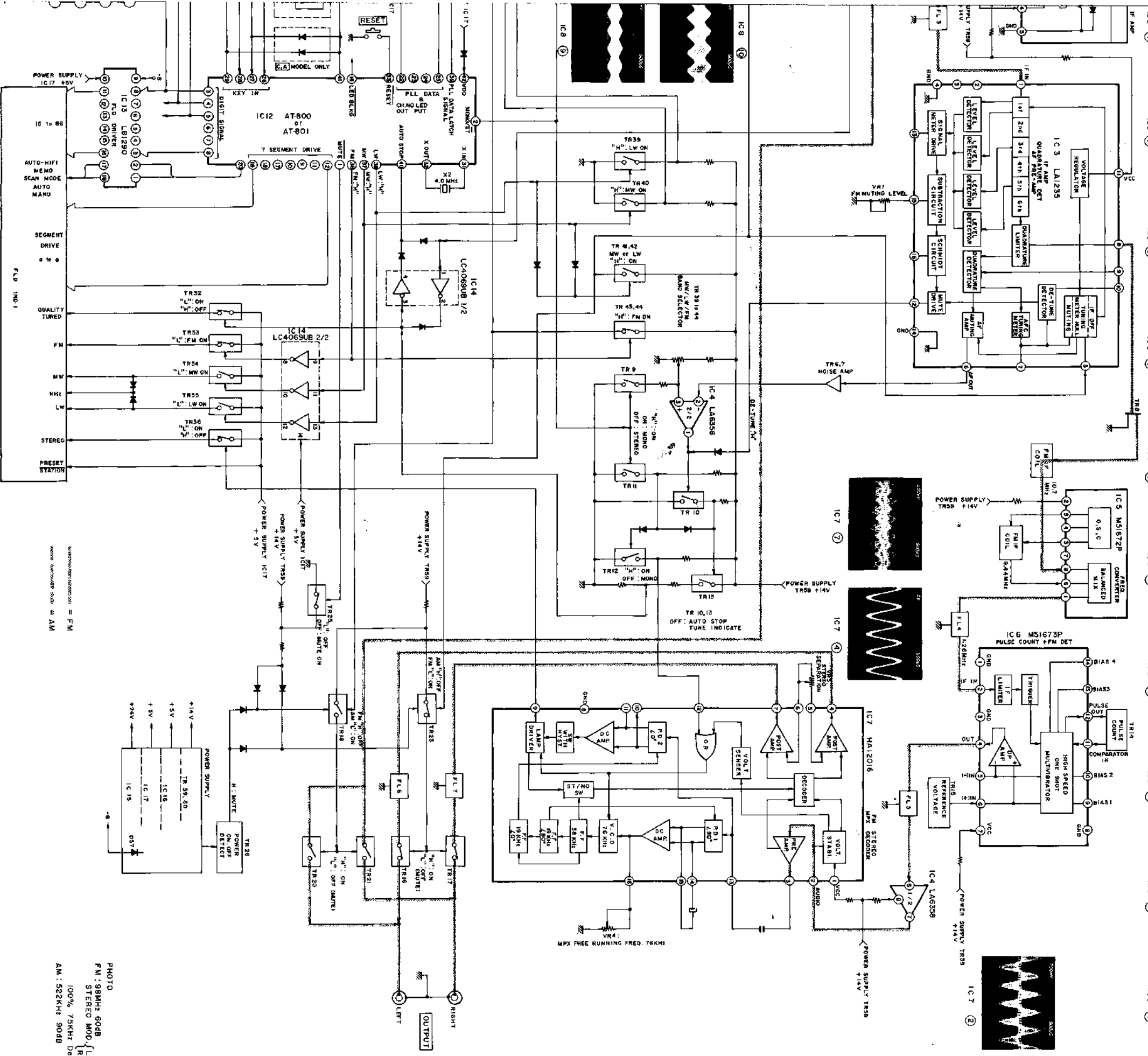
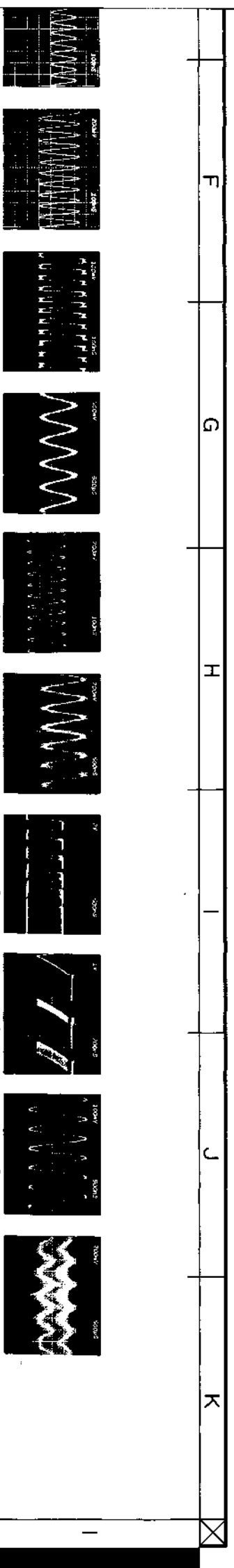

(TUNER)  
AT-S7/L  
BLOCK DIAGRAM  
NO.3-1 830801A

PHOTO  
FM: 98MHz 60dB  
STEREO MOD: L: 1KHz  
100% 75KHz Dev.  
AM: 522KHz 90dB

F G H I J K

8

7

6

5

4

3

2

1

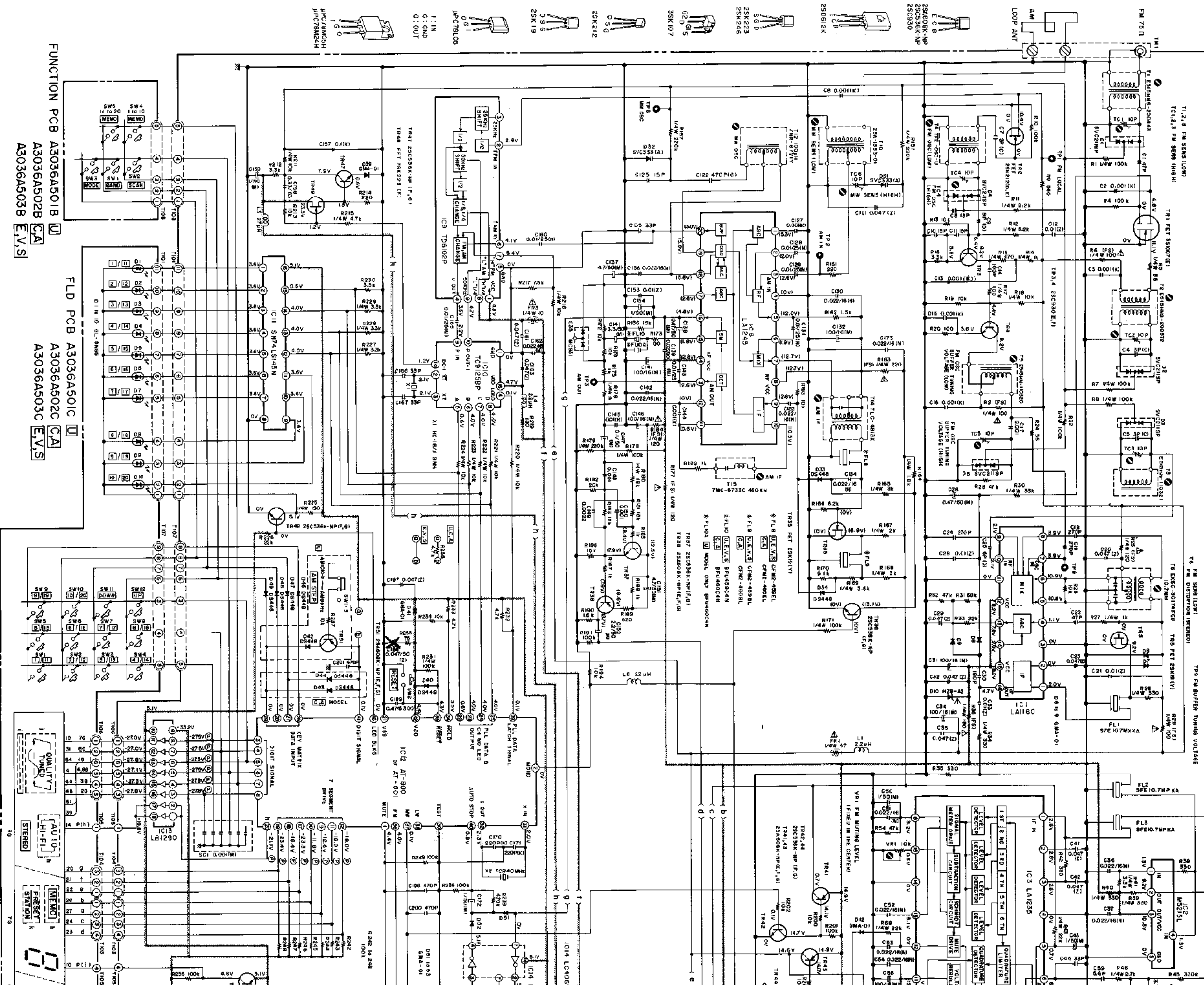

FUNCTION PCB A3036A501B  
 A3036A502B CA  
 A3036A503B EVS

FLD PCB A3036A501C  
 A3036A502C CA  
 A3036A503C EVS

X Lithiumbatterie 3.6V einsetzen

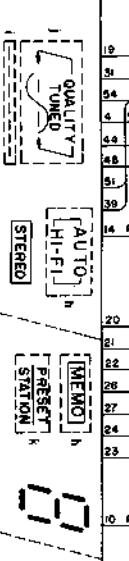

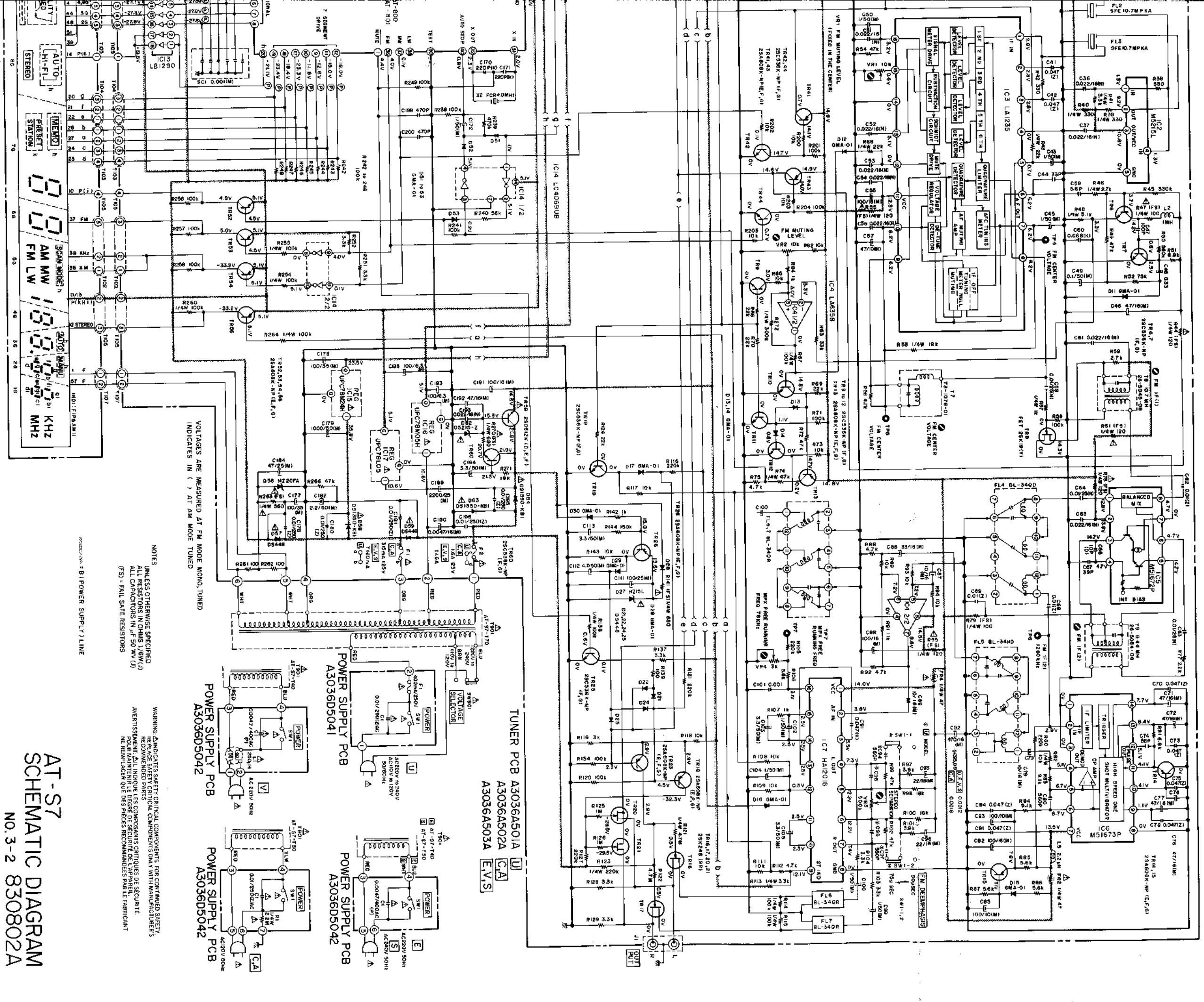

**AT-S7  
SCHEMATIC DIAGRAM  
NO. 3-2 830802A**

NOTES  
UNLESS OTHERWISE SPECIFIED  
ALL RESISTORS IN OHMS 1/8W (J)  
ALL CAPACITORS IN μF 50 WV (J)  
(FS) - FAIL SAFE RESISTORS

WARNING: INDICATES SAFETY CRITICAL COMPONENTS FOR CONTINUED SAFETY.  
REPLACE SAFETY CRITICAL COMPONENTS ONLY WITH MANUFACTURER'S  
RECOMMENDED PARTS.  
ADVERTISEMENT CALL INCLUDE LESS COMPONENTS OUTLINES DE SECURITE  
NE REMPLACER QUE DES PIÈCES RECOMMANDÉES PAR LE FABRICANT

einsetzen

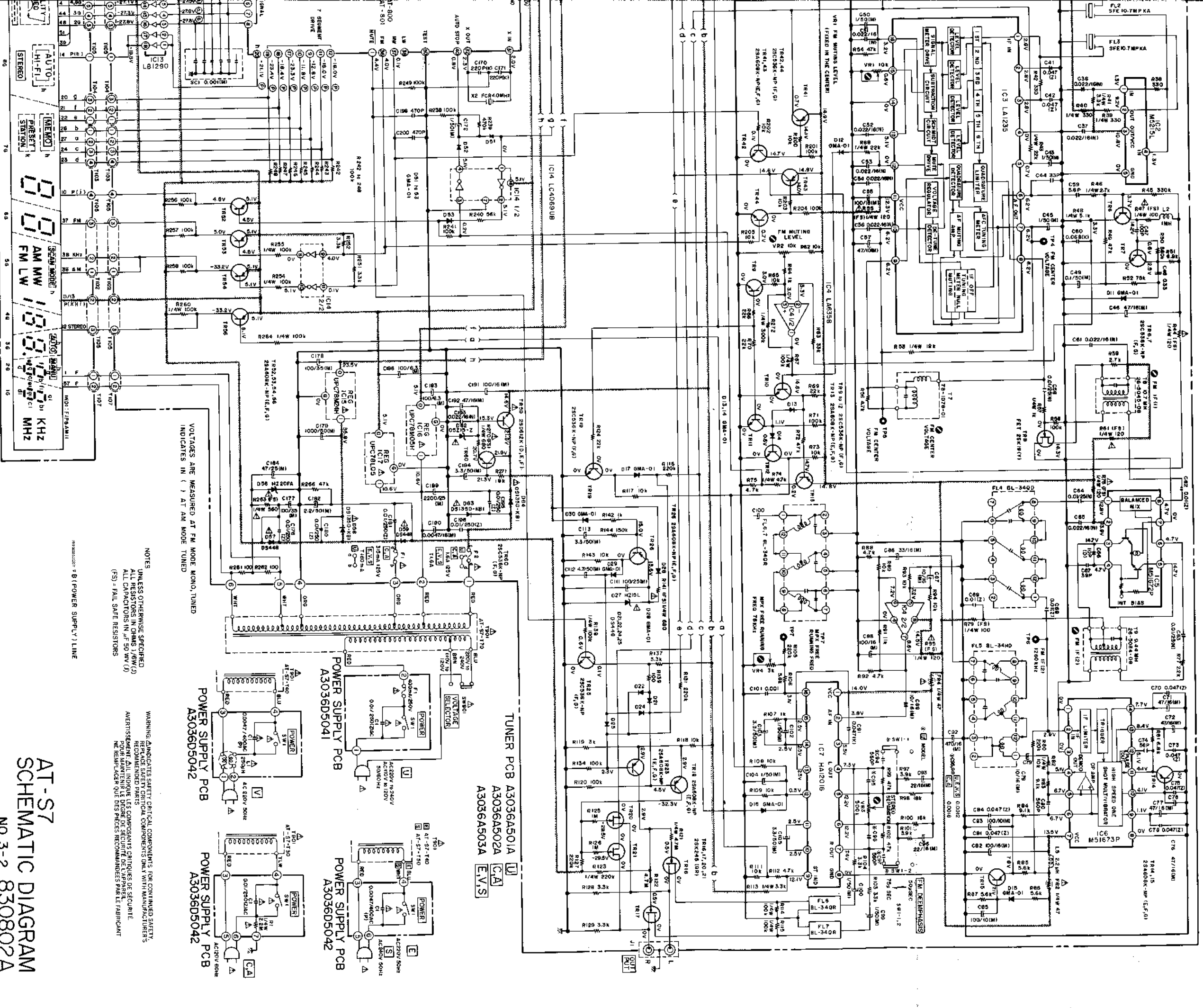

VOLTAGES ARE MEASURED AT FM MODE MONO, TUNED INDICATES IN ( ) AT AM MODE TUNED

NOTES  
UNLESS OTHERWISE SPECIFIED  
ALL RESISTORS IN OHMS 1/5W (J)  
ALL CAPACITORS IN  $\mu$ F 50 WV (J)  
(FS) = FAIL SAFE RESISTORS

WARNING: INDICATES SAFETY CRITICAL COMPONENTS FOR CONTINUED SAFETY. REPLACE SAFETY CRITICAL COMPONENTS ONLY WITH MANUFACTURER'S RECOMMENDED PARTS.  
AVERTISSEMENT: CIL INDIQUE LES COMPOSANTS CRITIQUES DE SECURITE. NE REMPLACEZ QUE DES PIECES RECOMMANDEES PAR LE FABRICANT.

**AT-S7  
SCHEMATIC DIAGRAM  
NO. 3-2 830802A**

W einsetzen

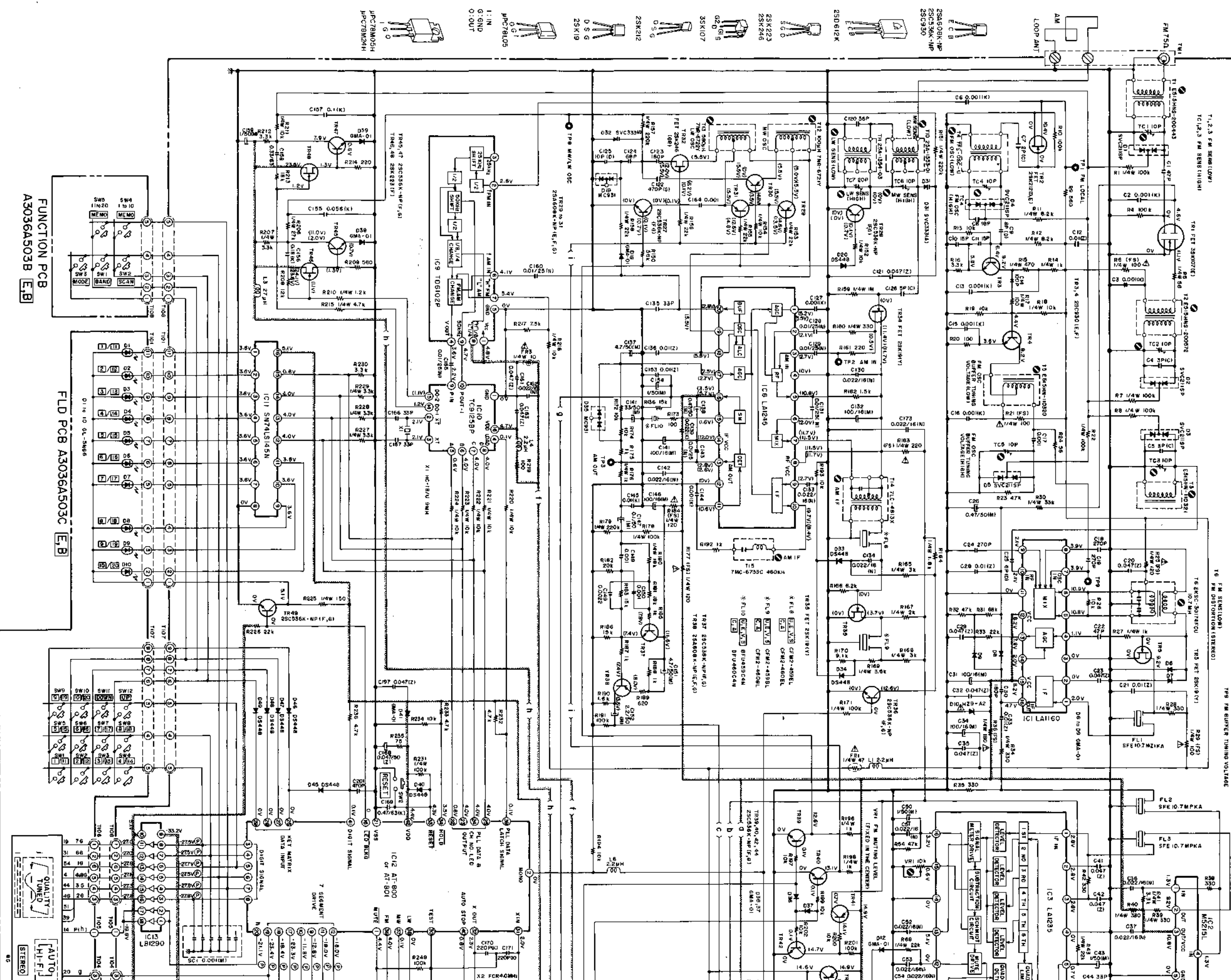

FUNCTION PCB  
A3036A503 B E,B

FLD PCB A3036A503C E,B

QUALITY TUNED HI-FI AUTO. STEREO

- 25A508K-NP
- 25C536K-NP
- 25C5930
- E C B
- 25A508K-NP
- 25C536K-NP
- 25C5930
- 25B612K
- 5 S 0
- 25K223
- 25K246
- 35K107
- 5 S 0
- 25K212
- 0 S 5
- 25K19
- JPC78105
- JPC78105
- JPC78105
- JPC78105
- JPC78105H
- JPC78105H

1 2 3 4 5 6 7 8

A B C D E F



# AKAI

## Memo

von: AKAI-Zentralkundendienst

an:

Datum: 04.09.86 wfs

Betr.: Tuner AT-S 7

Problem: In Einzelfällen fällt die Senderspeicherung nach 3 - 5 Tagen bei ausgeschaltetem Gerät aus.

Lösung: Der für die Senderspeicherung zuständige Kondensator sollte in einem solchen Fall durch eine Lithium-Batterie ersetzt werden.  
Sie kann bei uns mit der Bestell-Nr. EZ-354081 bezogen werden.

Wichtig: Lithium-Batterien neigen bei zu starker Erhitzung (z.B. beim Löten) zur Explosion! Achten Sie daher beim Löten unbedingt darauf, in der unten angegebenen Weise vorzugehen.

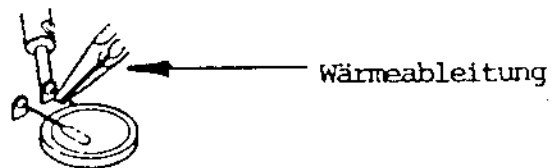
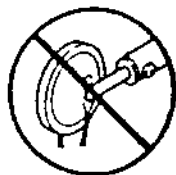

Wichtig: Lithium-Batterien sind nicht aufladbar! Auf keinen Fall laden!

Hinweis: Lebensdauer der Batterie: ca. 10 Jahre.

Beim Einsetzen der Batterie ist eine zusätzliche Germanium-Diode anstelle des Widerstandes R-235 einzulöten. Siehe dazu die nachfolgenden Schaltbild-Ausschnitte.

AT-S 7:

