

AKAI SERVICE MANUAL

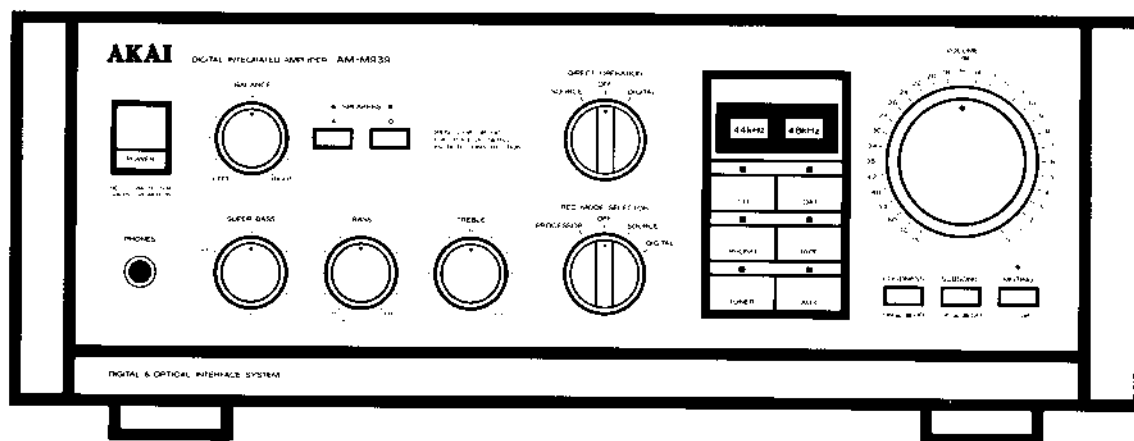

DIGITAL INTEGRATED AMPLIFIER

MODEL AM-M939

SPECIFICATIONS

Power output		S/N	
By FTC	80W + 80W/6 ohms	PHONO (MM)	8.5 dB
By DIN (1 kHz)	80W + 80W/6 ohms	TUNER etc.	100 dB
Power bandwidth	10 Hz to 60 kHz/0.1%	Channel separation	60 dB
Total harmonic distortion	0.008% (1 kHz, 8 ohms)	Audio mute	20 dB
PHONO max. input level	250 mV (MM)	Required speaker impedance	
Frequency response		A or B	6 to 16 ohms
PHONO	±0.2 dB	A + B	12 to 16 ohms
CD Direct	5 Hz to 100 kHz	D/A section	
Tone control		Digital input level/Impedance	0.5 Vp-p/75 ohms
Treble	±10 dB	Frequency response	5 Hz to 20 kHz ±3 dB
Bass	±10 dB	Dynamic range	95 dB
Super bass	+10 dB	Total harmonic distortion	0.003%
Input sensitivity/Impedance		Channel separation	90 dB (1 kHz)
PHONO (MM)	2.5 mV/47 kohms	Power requirements	220 V, 50 Hz for Europe except UK 240V, 50Hz for UK
TUNER etc.	150 mV/47 kohms	Dimensions	385 (W) × 139 (H) × 330 (D) mm (15.2 × 5.5 × 13.0 inches)
Output level/Impedance		Weight	10.3 kg (22.7 lbs)
TAPE REC OUT	150 mV/47 kohms		
Damping factor	30 (1 kHz)		
Residual noise	0.5 mV		

* For improvement purposes, specifications and design are subject to change without notice.

★ SAFETY INSTRUCTIONS

PRECAUTIONS DURING SERVICING

1. Parts identified by the Δ symbol parts are critical for safety. Replace only with parts number specified.
2. In addition to safety, other parts and assemblies are specified for conformance with such regulations as those applying to spurious radiation. These must also be replaced only with specified replacements.
Examples: RF converters, tuner units, antenna selector switches, RF cables, noise blocking capacitors, noise blocking filters, etc.
3. Use specified internal wiring. Note especially:
 - 1) Wires covered with PVC tubing
 - 2) Double insulated wires
 - 3) High voltage leads
4. Use specified insulating materials for hazardous live parts. Note especially:
 - 1) Insulation Tape
 - 2) PVC tubing
 - 3) Spacers (Insulating Barriers)
 - 4) Insulation sheets for transistors
 - 5) Plastic screws for fixing microswitch (especially in turntable)
5. When replacing AC primary side components (transformers, power cords, noise blocking capacitors, etc.), wrap ends of wires securely about the terminals before soldering.

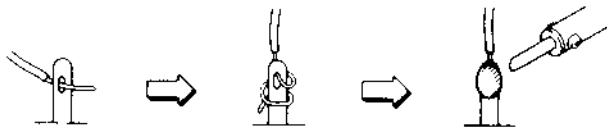

6. Observe that wires do not contact heat producing parts (heatsinks, oxide metal film resistors, fusible resistors, etc.).

7. Check that replaced wires do not contact sharp edged or pointed parts.
8. Also check areas surrounding repaired locations.
9. Use care that foreign objects (screws, solder droplets, etc.) do not remain inside the set.

SAFETY CHECK AFTER SERVICING

Confirm the specified insulation resistance between power cord plug prongs and externally exposed parts of the set is greater than 10 M ohms, but for equipment with external antenna terminals (tuner, receiver, etc.) and is intended for [C] or [A], specified insulation resistance should be headphone jacks line-in-out jacks etc. more than 2.2 M ohms (ground terminals, microphone jacks).

PRECAUTION FOR THE LITHIUM BATTERY

The LITHIUM BATTERY employed for memory Back up has a explosive probability when the BATTERY itself is excessive heated.

IN CASE OF REPLACING: RESOLDER and SOLDER AS RECOMMENDED WAY.

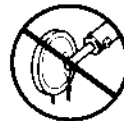

[DANGER]



[RECOMMENDED WAY]

★ INFORMATION

SYMBOLS FOR PRIMARY DESTINATION

Alphabet indicates the destination of the units as listed below.

Symbols	Principal Destinations
[A]	USA
[B]	UK
[C]	Canada
[E]	Europe (except UK)
[J]	Japan
[S]	Australia
[V]	W. Germany only
[U]	Universal Area
[Y*]	Custom version

I. CONTROLS

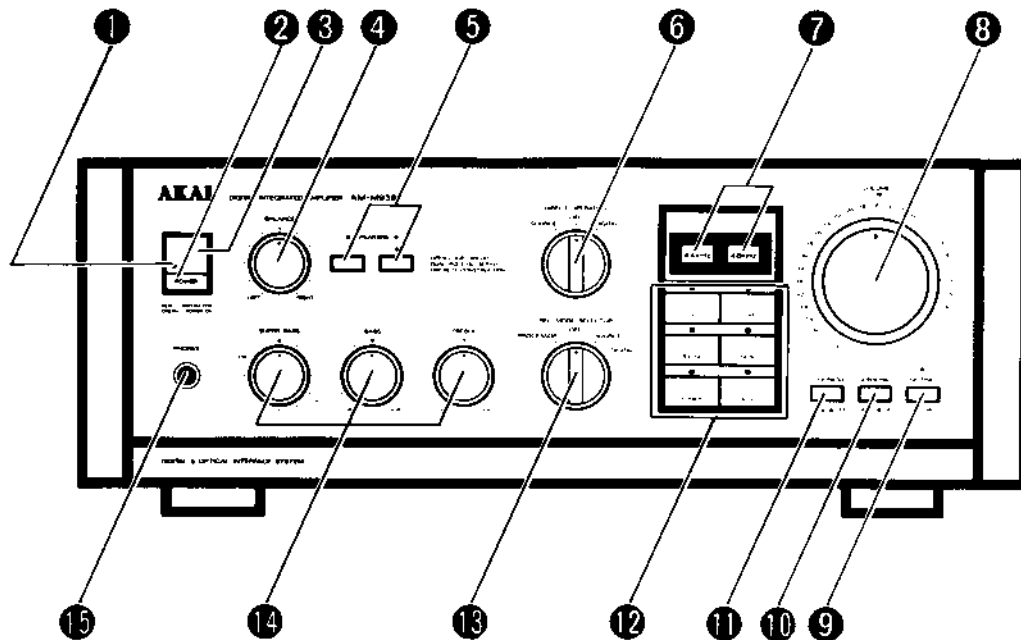

- 1 POWER Indicator**
Indicates the power is turned on. Also indicates the speaker protection circuit operation. When the speaker protection system is engaged, the indicator will be red.
- 2 POWER Switch**
To turn the Akai amplifier on and off.
- 3 Remote control receiver**
For remote control operation.
- 4 BALANCE Control**
To adjust the left and right channel balance.
- 5 A/B SPEAKERS Switches and Indicators**
To select the speaker system.
- 6 DIRECT OPERATION Switch**
To select the playback operation mode of the Akai amplifier.
- 7 SAMPLING FREQUENCY Displays (44 kHz/48 kHz)**
Shows which digital input signal has been selected when using the digital interface connections.
44 kHz: CD player's signal is selected.
48 kHz: DAT deck's signal is selected.
- 8 VOLUME (-dB: minus decibel) Control**
To adjust the volume level. The 0 dB (zero decibel) position is the maximum volume of the amplifier.
- 9 MUTING Switch and Indicator**
To reduce volume instantly during playback without using the VOLUME control.
- 10 SUBSONIC Switch (ON /OFF)**
To turn the subsonic filter on and off.
- 11 LOUDNESS Switch (ON /OFF)**
For instant compensation of tone setting at low volume.
- 12 Input select buttons and Indicators**
To select the playback source you want to listen to.
- 13 REC MODE SELECTOR Switch (PROCESSOR/OFF/SOURCE/DIGITAL)**
For recording operation.
- 14 Tone controls (SUPER BASS/BASS/TREBLE)**
To adjust the super bass note (super bass), bass note (bass) and high note (treble) levels.
- 15 Headphones (PHONES) jack**
For headphone listening.

II. DISASSEMBLY

In case of trouble, etc. necessitating dismantling, please dismantle in the order shown in the photographs. Reassemble in reverse order.

1 Removal of Side Boards and Upper Cover

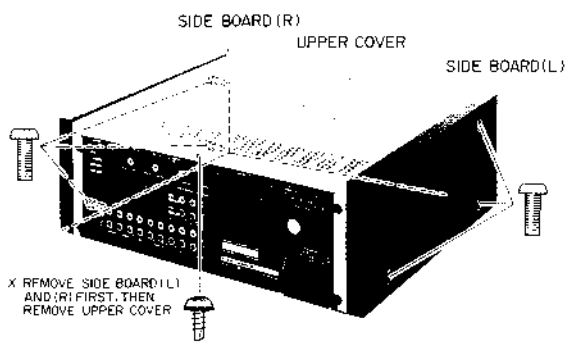

2 Removal of Bottom Plate

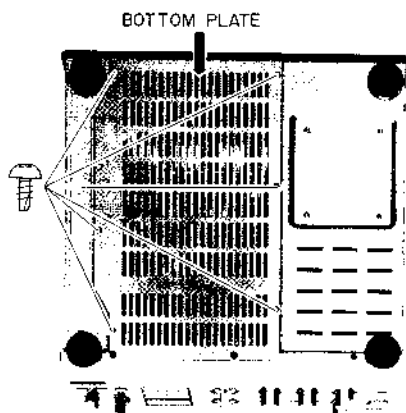

3 Removal of Front Panel

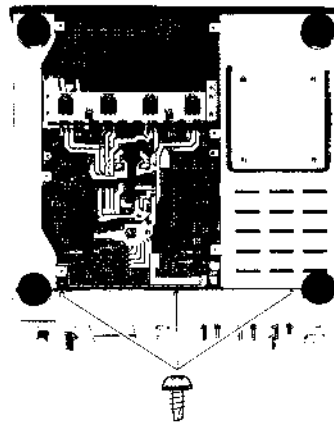

4

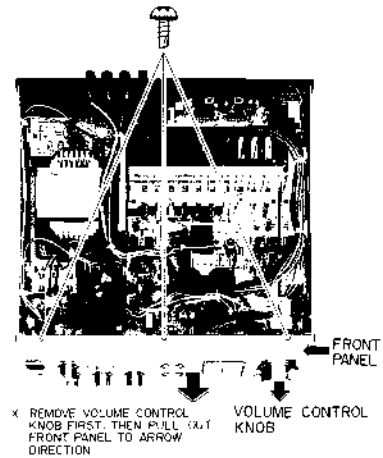

5

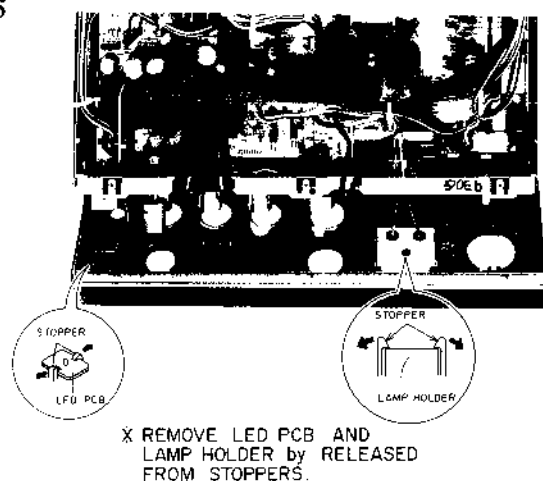

III. PRINCIPAL PARTS LOCATION

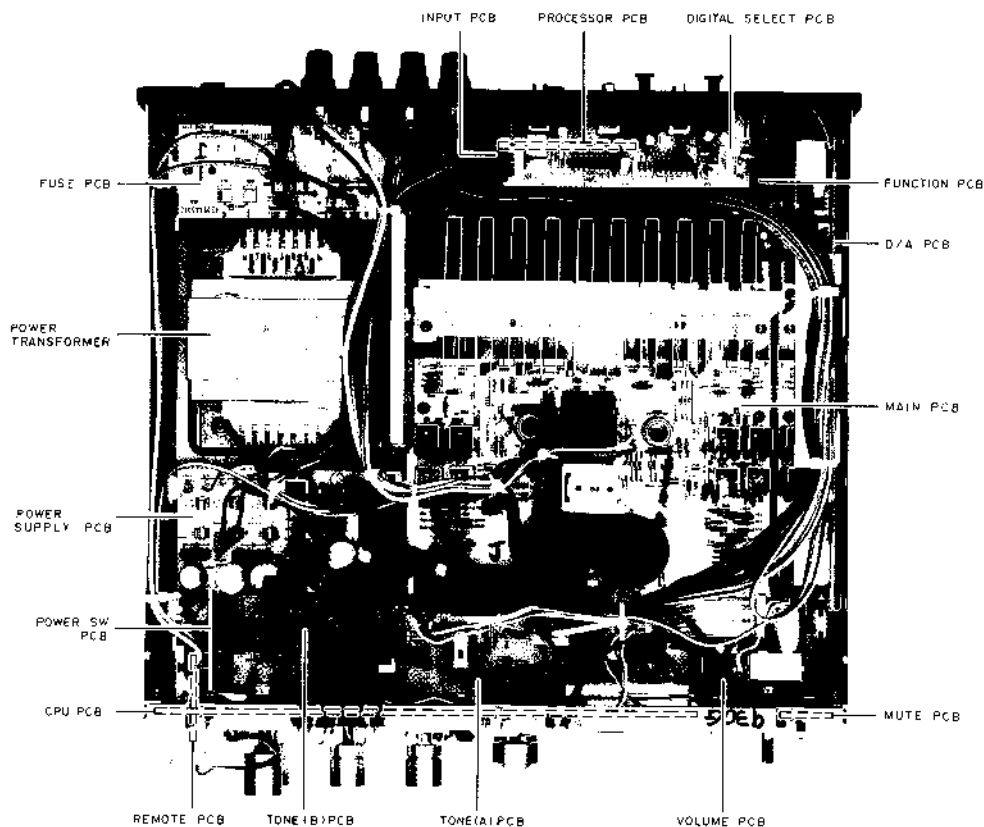

IV. ELECTRICAL ADJUSTMENT

4-1. IDLING CURRENT ADJUSTMENT

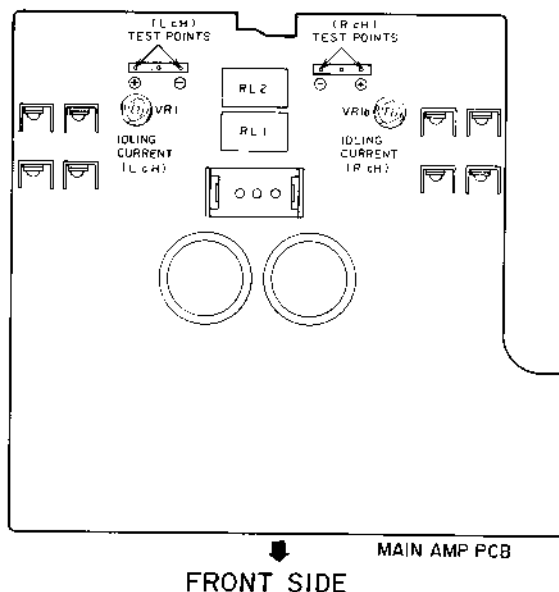

Fig. 4-1 Adjustment points and test points of MAIN AMP PCB

NOTE: This adjustment is done at the condition of no signal input and volume control knob is at the minimum position, also, this adjustment is done after 1 minute pass from the power is turned on.

- 1) Connect a digital DC Voltmeter between \oplus and \ominus terminals of the test points L or R CH.
- 2) Adjust VR1 (L CH) or VR1b (R CH) so that the reading on the Digital Voltmeter is 20 mV.

4-2. ADJUSTMENT OF D/A PC BOARD

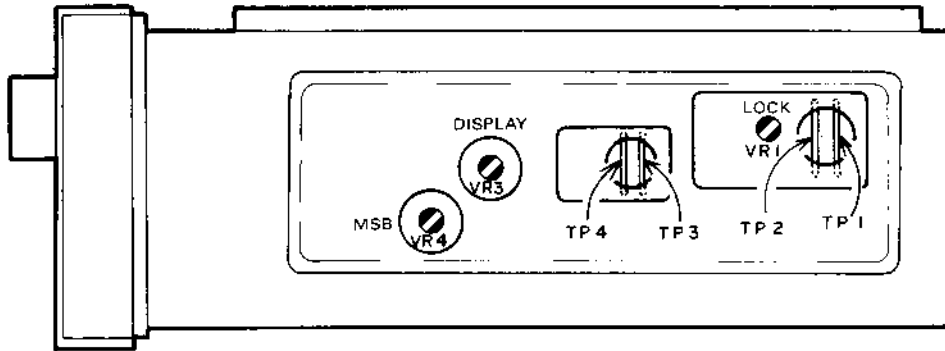

Fig. 4-2 Test points and Adjustment points of D/A PC Board

4-2-1. LOCK ADJUSTMENT OF PLL CIRCUIT

- 1) Connect the CD player which has digital output such as CD-M939 to CD DIGITAL INPUT.
- 2) Connect the oscilloscope to TP1 and adjust VR1 (LOCK) so that the timing of waveform on the oscilloscope as in Fig. 4-3.

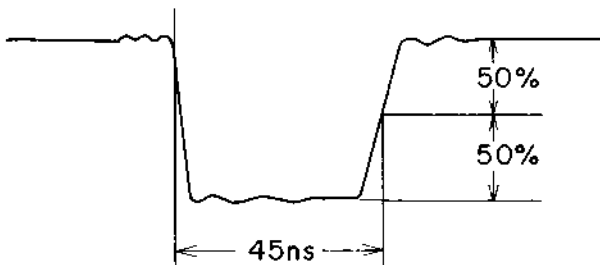

Fig. 4-3

4-2-2. MSB ADJUSTMENT

- 1) Connect the Distortion meter to analog REC OUT.
- 2) Connect the CD player which has digital output such as CD-M939 to CD DIGITAL INPUT. Then play back the 1 kHz of TEST DISC TYPE III (AT-711881).
- 3) Adjust VR4(MSB) so that the reading on the Distortion meter is minimum.

4-2-3. CONFIRMATION OF THE SAMPLING FREQUENCY INDICATOR

- 1) Connect the CD player and DAT which has digital output such as CD-M939 and AD-M939 to each DIGITAL INPUT.
- 2) When set the INPUT selector to CD or DAT, confirm that the sampling frequency indicator is indicated 44k Hz at CD mode or 48kHz at DAT mode. If the correct indication is not obtained adjust VR3(DISPLAY) so that the correct indication is obtained as in the above.

V. PARTS LIST

ATTENTION

1. When placing an order for parts, be sure to list Part No., Model No. and the description of each part. Otherwise, the non-delivery of the part or the delivery of a wrong part may result.
2. Please make sure that Part No. is correct when ordering.
If not, a part different from the one you ordered may be delivered.
3. Since the parts shown in Parts List of Preliminary Service Manual may have been the subject of changes, please use this Parts List for all future reference.

HOW TO USE THIS PARTS LIST

1. This Parts List lists those parts which are considered necessary for repairs. Other common parts, such as resistors and capacitors, are listed in the "Common List for Service Parts" from which these parts should be selected and stocked.
2. The Recommended Spare Parts List shows those parts in the Parts List which are considered particularly important for service.
3. Parts not shown in the Parts List and "Common List for Service Parts" will not in principle be supplied.
4. How to read the Parts List.

a) Mechanism Block

b) PC Board

2. HEAD BASE BLOCK

REF. NO.	PART NO.	DESCRIPTION
2-1x	BH-T2023A320A	HEAD BASE BLOCK
2-2	HP-H2206A010A	HEAD R/P PR4-8FU C
2-3	ZS-477876	PAN20×03STL CMT
2-4	ZS-536488	BID20×08STL CMT
2-5	ZG-402895	SP CS ANGLE ADJUST

- SP (Service Parts) Classification
- A small "x" indicates that this part is not shown in the Photo or Illustration.
- This number corresponds with the individual parts index number in that figure.
- This number corresponds with the Figure Number.

6. MAIN PC BOARD

REF. NO.	PART NO.	DESCRIPTION
6-IC1	EI-324536	IC HD14049BP
6-IC2	EI-336801	IC MB8841-564M
6-C1A	EC-338399	C MMY V 223M 250AC [U,E,B,S]
6-C1B	EC-350949	C MMY V 223M 250DC [J]
6-C1C	EC-338397	C MMY V 223M 125AC [C,A]
6-X1	EI-318384	OSC X'TAL NC-18C

- Symbols for primary destination
- [A]: AAL(U.S.A.) [S]: SAA(Australia)
- [B]: BEAB(England) [U]: U/T(Universal Area)
- [C]: CSA(Canada) [V]: VDE(W. Germany)
- [E]: CEE(Europe) [Y]: Custom Version
- [J]: JPN(Japan)
- SP (Service Parts) Classification
- These reference symbols correspond with component symbols in the Schematic Diagrams.

The available PC Board Blocks are listed separately.

5. When Part No. is known, Parts Index at end of Parts List can be used to locate where that part is shown in Parts List by its Reference No. listed at right of Part No.

WARNING

△ (*) INDICATES SAFETY CRITICAL COMPONENTS. FOR CONTINUED SAFETY, REPLACE SAFETY CRITICAL COMPONENTS ONLY WITH MANUFACTURE'S RECOMMENDED PARTS.

AVERTISSEMENT

△ (*) IL INDIQUE LES COMPOSANTS CRITIQUES DE SÉCURITÉ. POUR MAINTENIR LE DEGRÉ DE SÉCURITÉ DE L'APPAREIL, NE REMPLACER QUE DES PIÈCES RECOMMANDÉES PAR LE FABRICANT.

1. RECOMMENDED SPARE PARTS

We suggest you to stock the following Recommended Spare Part items listed below since they can cover most of the routine service.

Ref. No.	Part No.	Description
1	*BT-368203	TRANS POW A2054-B [B]
2	*BT-368202	TRANS POW A2054-E.V [E.V]
3	BT-368261	TRANS PULSE TC-1027-04
4	ED-368248	D LED SLB-221PVW RED&GREEN [POWER & PROTECTION]
5	ED-376939	D LED SLR56PC 3F GREEN [SPEAKER A]
6	ED-376938	D LED SLR56VC 3F RED [MUTING]
7	ED-360409	D PHOTO PN323B
8	*ED-330319	D SILICON DBA10B 100/1.0A
9	ED-348990	D SILICON H DS446
10	ED-301911	D SILICON H DS448
11	ED-344280	D SILICON H GMA-01-FY2 F05
12	*ED-348786	D SILICON RB154 400/1.5A
13	*ED-368225	D SILICON RB802 200/6.0A
14	ED-378503J	D ZENER H HZS20J B1 F05
15	ED-346554	D ZENER H HZ11L C3
16	ED-346567	D ZENER H HZ16L 1
17	ED-346571	D ZENER H HZ20L 1
18	ED-330219	D ZENER H HZ20L 2
19	ED-346576	D ZENER H HZ24L 1
20	ED-337990	D ZENER H HZ27L 1
21	ED-338333	D ZENER H HZ5 B2
22	ED-343410	D ZENER H HZ6L A1
23	ED-346525	D ZENER H HZ6L A3
24	ED-346528	D ZENER H HZ6L C1
25	ED-346532	D ZENER H HZ7L A3
26	*EF-364518	FUSE BET T 250V 2.50A [B]
27	*EF-358974	FUSE BET T 250V 630MA [B]
28	*EF-623125	FUSE SEMKO T 250V 2.50A [E.V]
29	*EF-601942	FUSE SEMKO T 250V 630MA [E.V]
30	EH-368606	FILTER LC LP BL-21SR 20KHZ
31	EI-362973	IC AK-80
32	EI-373980	IC BA15218N
33	EI-368253	IC CXD1076
34	EI-345474	IC HA12002
35	EI-368231	IC LC6543C-*** A2054 CUSTOM
36	EI-368240	IC LC7822
37	EI-375346	IC MM74HC04N
38	EI-344764	IC M5218P-21
39	EI-362588	IC M5238P
40	EI-368612	IC PCM56P
41	EI-368254	IC SN74LS624
42	EI-332259	IC TC40526P
43	EI-360040	IC TC74HCU04P
44	EI-360038	IC TC74HC02P
45	EI-368255	IC TC74HC112
46	EI-365098	IC TC74HC123P
47	EI-360027	IC TC74HC86P
48	EI-367271	IC UPC1490HA
49	EI-349372	OSC CE CSA4.00MG 4MHZ
50	EJ-368258	SOCKET OPTICAL TORX172 [CD OPTICAL]
51	EL-368264	PL CORD 14.0V 100MA 200/200 [SAMPLING 48KHZ]
52	*EO-338409	COIL LF FKOB160MH02 250UH [V]
53	EQ-337159	RELAY POW G4Z-2282P 2NO 24V
54	EQ-344440-A	RELAY SIG G2VN-287P 2TR 24V
55	ER-378504J	R CB H S10 FS RDS 1/4W 121J
56	*ER-345751	R FUSE H S10 ERD2FC 1/4W 15R0G
57	*ES-361970	SW PUSH SDDL1 01-1 [POWER SW]

Ref. No.	Part No.	Description
58	ES-368227	SW PUSH SPUL** 2 THROW N [LOUDNESS/SUBSONIC]
59	ES-368237	SW ROTARY SRBU*** [REC MODE SELECTOR]
60	ES-368236	SW ROTARY SRRU*** [DIRECT OPERATION]
61	ES-349474	SW TACT SKHHAM004A [CD]
62	ET-354415	TR DTA144ES
63	ET-360399	TR DTC114TS
64	ET-354365	TR DTC114YS
65	ET-354371	TR DTC124ES
66	ET-354094	TR DTC144WS
67	ET-368249	TR DTD114TS
68	ET-348898	TR 2SA1115 E.F.G F05
69	ET-321016	TR FET 2SK117 GR,BL
70	ET-354897	TR FET 2SK170 BL,GR,V
71	ET-337759	TR FET 2SK246 GR
72	ET-308472	TR 2SA1115 E.F.G F05
73	ET-338244	TR 2SA1207 R.S
74	ET-348829	TR 2SA1209 S.T
75	*ET-345626	TR 2SA1248 S.T
76	ET-353899	TR 2SA1317 S.T,U
77	ET-349593	TR 2SA1348 F05
78	*ET-368758	TR 2SA1491 P.Y [TR903]
79	*ET-327714	TR 2SB631K F
80	ET-308141	TR 2SC2603 G F05
81	ET-338410	TR 2SC2878 A,B
82	ET-348830	TR 2SC2909 S.T
83	ET-348831	TR 2SC2911 S.T
84	ET-338869	TR 2SC2999 C,D
85	*ET-345625	TR 2SC3116 S.T
86	ET-360067	TR 2SC3330 T,U F05
87	ET-349081	TR 2SC3383 S.T
88	ET-349592	TR 2SC3400 F05
89	*ET-368760	TR 2SC3855 P.Y [TR902]
90	*ET-368251	TR 2SC3964 [TR901]
91	*ET-362113	TR 2SD1406 Y,GR
92	*ET-321596	TR 2SD600K F
93	*ET-310148	TR 2SD612K E.F
94	EV-368268	VR ROTARY *A2054 B104X2 [SUPER BASS]
95	EV-355457	VR ROTARY RKDA2S 100KCX2 [BASS]
96	EV-355466	VR ROTARY RKDA20 100KCX2 [TREBLE]
97	EV-368235	VR ROTARY RK1631110 SPCL W105 [BALANCE]
98	EV-368245	VR SPL RK16312MA [VOLUME]
99	EZ-358816	BATTERY LITHIUM BR2032-1HF

2. P.C BOARD BLOCK

Ref. No.	Part No.	Description
1A	BA-A2054A020B	PC(##) MAIN AMP BLK AM-M939(E) [E.B]
1B	BA-A2054A020C	PC(##) MAIN AMP BLK AM-M939(V) [V]
2A	BA-A2054A030A	PC(##) CPU BLK DA-U930(J) [E.B]
2B	BA-A2054A030B	PC(##) CPU BLK AM-M939(V) [V]
3	BA-A2054A040A	PC(##) D/A BLK DA-U930

PC (##) MAIN AMP BLK CONSISTS OF FOLLOWING P.C BOARD.

- MAIN AMP P.C BOARD
- POWER SUPPLY P.C BOARD
- FUSE P.C BOARD
- POWER SW P.C BOARD
- PHONE P.C BOARD

PC (##) CPU BLK CONSISTS OF FOLLOWING P.C BOARD.

- CPU P.C BOARD
- TONE (A) P.C BOARD
- TONE (B) P.C BOARD
- FUNCTION P.C BOARD
- JACK P.C BOARD
- PROCESSOR P.C BOARD
- VOLUME P.C BOARD
- MUTE P.C BOARD
- LED P.C BOARD
- REMOTE P.C BOARD

PC (##) D/A BLK CONSISTS OF FOLLOWING P.C BOARD.

- D/A P.C BOARD
- TONE (A) P.C BOARD
- DIGITAL SELECTOR P.C BOARD

3. MAIN AMP P.C BOARD

Ref. No.	Part No.	Description
C5	EC-368222	C EC P SNP 103M 56.0DC
C6	EC-368222	C EC P SNP 103M 56.0DC
C10	EC-355461	C MY V MKT 334K 100DC
C18	EC-326583	C MMY V CUT CF921 473K 400DC
D1	ED-330219	D ZENER H HZ20L 2
D2	ED-330219	D ZENER H HZ20L 2
D3	ED-343410	D ZENER H HZ6L A1
D4	ED-346554	D ZENER H HZ11L C3
D5	ED-346554	D ZENER H HZ11L C3
D6	ED-348990	D SILICON H DS446
D7	ED-348990	D SILICON H DS446
D8	ED-301911	D SILICON H DS448
D9	ED-301911	D SILICON H DS448
D10	ED-301911	D SILICON H DS448
D11	ED-301911	D SILICON H DS448
D12	ED-301911	D SILICON H DS448
D13	ED-348990	D SILICON H DS446
D14	ED-348990	D SILICON H DS446
D15	*ED-368225	D SILICON RB602 200/6.0A
IC1	EI-362588	IC M5238P
IC2	EI-345474	IC HA12002
L1	EO-332116	COIL FIX 2 103AK-006A 2R2K
RL1	EQ-337159	RELAY POW G4Z-2282P 2NO 24V
RL2	EQ-337159	RELAY POW G4Z-2282P 2NO 24V
R6	ER-368282	R OMF H S15 FS 2W 332J
R7	ER-368282	R OMF H S15 FS 2W 332J
R17	ER-375106	R CB H S10 FS RDS 1/4W 221J
R18	ER-375106	R CB H S10 FS RDS 1/4W 221J
R22	ER-378643J	R OMF H S12 FS 1W 682J
R23	ER-378643J	R OMF H S12 FS 1W 682J
R24	ER-378497J	R CB H S10 FS RDS 1/4W 271J
R25	ER-378497J	R CB H S10 FS RDS 1/4W 271J
R31	ER-378501J	R CB H S10 FS RDS 1/4W 302J
R32	ER-378502J	R CB H S10 FS RDS 1/4W 391J
R33	ER-378499J	R CB H S10 FS RDS 1/4W 100J
R34	ER-378499J	R CB H S10 FS RDS 1/4W 100J
R35	ER-372990	R CB H S10 FS RDS 1/4W 150J
R36	ER-372990	R CB H S10 FS RDS 1/4W 150J
R39	ER-368226	R CT P R33+R33 5W
R40	ER-368285	R OMF H S15 FS 2W 120J
R41	ER-368285	R OMF H S15 FS 2W 120J

Ref. No.	Part No.	Description
R57	ER-368282	R OMF H S15 FS 2W 332J
SW1	ES-368227	SW PUSH SPUL** 2 THROW N [LOUDNESS/SUBSONIC]
TR1	ET-321016	TR FET 2SK117 GR.BL
TR2	ET-348831	TR 2SC2911 S.T
TR3	ET-348829	TR 2SA1209 S.T
TR4	ET-348830	TR 2SC2909 S.T
TR5	ET-348830	TR 2SC2909 S.T
TR6	ET-348831	TR 2SC2911 S.T
TR7	ET-348829	TR 2SA1209 S.T
TR8	ET-348831	TR 2SC2911 S.T
TR9	ET-348829	TR 2SA1209 S.T
TR10	ET-348830	TR 2SC2909 S.T
TR11	ET-338244	TR 2SA1207 R.S
VR1	EV-380204	R S-FIX HRH1051C 0.15W 102

4. POWER SUPPLY P.C BOARD

Ref. No.	Part No.	Description
D101	ED-337990	D ZENER H HZ27L 1
D102	ED-337990	D ZENER H HZ27L 1
D103	ED-337990	D ZENER H HZ27L 1
D104	ED-337990	D ZENER H HZ27L 1
D105	ED-346567	D ZENER H HZ16L 1
D106	ED-346567	D ZENER H HZ16L 1
D107	ED-346528	D ZENER H HZ6L C1
D108	ED-346528	D ZENER H HZ6L C1
D109	ED-346571	D ZENER H HZ20L 1
D110	ED-346576	D ZENER H HZ24L 1
D111	ED-346532	D ZENER H HZ7L A3
D112	*ED-348786	D SILICON RB154 400/1.5A
D113	*ED-330319	D SILICON DBA10B 100/1.0A
D114	ED-346525	D ZENER H HZ6L A3
D115	ED-378503J	D ZENER H HZS20J B1 F05
D116	ED-378503J	D ZENER H HZS20J B1 F05
D117	ED-344280	D SILICON H GMA-01-FY2 F05
D118	ED-344280	D SILICON H GMA-01-FY2 F05
R103	ER-378504J	R CB H S10 FS RDS 1/4W 121J
R104	ER-378504J	R CB H S10 FS RDS 1/4W 121J
R105	ER-378504J	R CB H S10 FS RDS 1/4W 121J
R106	ER-378504J	R CB H S10 FS RDS 1/4W 121J
R107	ER-378499J	R CB H S10 FS RDS 1/4W 100J
R108	ER-378504J	R CB H S10 FS RDS 1/4W 121J
R109	ER-378504J	R CB H S10 FS RDS 1/4W 121J
R110	ER-368286	R OMF H S12 FS 1W 241J
R111	ER-368286	R OMF H S12 FS 1W 241J
R112	ER-378504J	R CB H S10 FS RDS 1/4W 121J
TR101	ET-337759	TR FET 2SK246 GR
TR102	ET-337759	TR FET 2SK246 GR
TR103	*ET-345625	TR 2SC3116 S.T
TR104	*ET-345626	TR 2SA1248 S.T
TR105	ET-337759	TR FET 2SK246 GR
TR106	ET-337759	TR FET 2SK246 GR
TR107	*ET-321596	TR 2SD600K F
TR108	*ET-327714	TR 2SB831K F
TR109	ET-337759	TR FET 2SK246 GR
TR110	*ET-310148	TR 2SD612K E.F
TR111	ET-337759	TR FET 2SK246 GR
TR112	*ET-362113	TR 2SD1406 Y,GR
TR113	ET-337759	TR FET 2SK246 GR
TR114	*ET-362113	TR 2SD1406 Y,GR
TR115	ET-337759	TR FET 2SK246 GR
TR116	ET-362113	TR 2SD1406 Y,GR
F3A	*EF-601942	FUSE SEMKO T 250V 630MA [E.V]
F4A	*EF-601942	FUSE SEMKO T 250V 630MA [E.V]
F5A	*EF-601942	FUSE SEMKO T 250V 630MA [E.V]
F3B	*EF-358974	FUSE BET T 250V 630MA [B]
F4B	*EF-358974	FUSE BET T 250V 630MA [B]
F5B	*EF-358974	FUSE BET T 250V 630MA [B]

5. FUSE P.C BOARD

Ref. No.	Part No.	Description
F1A	*EF-623125	FUSE SEMKO T 250V 2.50A [E,V]
F1B	*EF-364518	FUSE BET T 250V 2.50A [B]
LV201	*EO-338409	COIL LF FKOB160MH02 250UH [V]

6. POWER SW P.C BOARD

Ref. No.	Part No.	Description
C301	*EC-338496	C CE V FZ 472P 400AC
SW301	*ES-361970	SW PUSH SDDL B1 01-1 [POWER SW]

7. PHONE P.C BOARD

Ref. No.	Part No.	Description
J401	EJ-369995	PHONE J 3P HLJ0540-410 GP 6.3 [PHONES]
R401	ER-378517J	R OMF H S15 FS 2W 681J

8. CPU P.C BOARD

Ref. No.	Part No.	Description
BT1	EZ-358816	BATTERY LITHIUM BR2032-1HF
D1	ED-301911	D SILICON H DS448
D2	ED-301911	D SILICON H DS448
D3	ED-301911	D SILICON H DS448
D4	ED-376939	D LED SLR56PC 3F GREEN [CD]
D5	ED-376939	D LED SLR56PC 3F GREEN [PHONO]
D6	ED-376939	D LED SLR56PC 3F GREEN [TUNER]
D7	ED-376939	D LED SLR56PC 3F GREEN [DAT]
D8	ED-376939	D LED SLR56PC 3F GREEN [TAPE]
D9	ED-376939	D LED SLR56PC 3F GREEN [AUX]
D10	ED-376939	D LED SLR56PC 3F GREEN [SPEAKER A]
D11	ED-376939	D LED SLR56PC 3F GREEN [SPEAKER B]
D14	ED-301911	D SILICON H DS448
D15	ED-301911	D SILICON H DS448
IC1	EI-368231	IC LC6543C-*** A2054 CUSTOM
R10	ER-378608J	R OMF H S12 FS 1W 152J
R11	ER-378608J	R OMF H S12 FS 1W 152J
TR1	ET-360067	TR 2SC3330 T.U F05
TR2	ET-354365	TR DTC114YS
TR3	ET-360399	TR DTC114TS
TR4	ET-354094	TR DTC144WS
TR5	ET-354365	TR DTC114YS
TR6	ET-354365	TR DTC114YS
TR7	ET-354365	TR DTC114YS
TR8	ET-353899	TR 2SA1317 S.T.U

Ref. No.	Part No.	Description
TR9	ET-360399	TR DTC114TS
TR10	ET-368249	TR DTD114TS
TR11	ET-368249	TR DTD114TS
TR12	ET-360399	TR DTC114TS
TR13	ET-360399	TR DTC114TS
TR14	ET-360399	TR DTC114TS
TR15	ET-360399	TR DTC114TS
TR16	ET-354371	TR DTC124ES
TS1	ES-349474	SW TACT SKHAM004A [CD]
TS2	ES-349474	SW TACT SKHAM004A [PHONO]
TS3	ES-349474	SW TACT SKHAM004A [TUNER]
TS4	ES-349474	SW TACT SKHAM004A [DAT]
TS5	ES-349474	SW TACT SKHAM004A [TAPE]
TS6	ES-349474	SW TACT SKHAM004A [AUX]
TS7	ES-349474	SW TACT SKHAM004A [SPEAKER B]
TS8	ES-349474	SW TACT SKHAM004A [SPEAKER A]
X1	EI-349372	OSC CE CSA4.00MG 4MHZ

9. TONE (A) P.C BOARD

Ref. No.	Part No.	Description
D101	ED-301911	D SILICON H DS448
IN101	EL-368264	PL CORD 14.0V 100MA 200/200 [SAMPLING 48KHZ]
IN102	EL-368264	PL CORD 14.0V 100MA 200/200 [SAMPLING 44KHZ]
RL101	EQ-344440-A	RELAY SIG G2VN-287P 2TR 24V
R105	ER-355214	R OMF H S15 FS 2W 151J
R112	ER-364696	R OMF H S15 FS 2W 221J
SW101	ES-368236	SW ROTARY SRRU*** [DIRECT OPERATION]
TR101	ET-368249	TR DTD114TS
TR102	ET-368249	TR DTD114TS
TR103	ET-368249	TR DTD114TS
TR104	ET-338410	TR 2SC2878 A,B
TR105	ET-349592	TR 2SC3400 F05
TR106	ET-349593	TR 2SA1348 F05
VR101	EV-368235	VR ROTARY RK1631110 SPCL W'05 [BALANCE]

10. TONE (B) P.C BOARD

Ref. No.	Part No.	Description
IC201	EI-373980	IC BA15218N
SW201	ES-368237	SW ROTARY SRRU*** [REC MODE SELECTOR]
VR201	EV-355466	VR ROTARY RKDA20 100KCX2 [TREBLE]
VR202	EV-355467	VR ROTARY RKDA2S 100KCX2 [BASS]
VR203	EV-368268	VR ROTARY *A2054 8104X2 [SUPER BASS]

11. FUNCTION P.C BOARD

Ref. No.	Part No.	Description
D301	ED-344280	D SILICON H GMA-01-FY2 F05
IC301	EI-368240	IC LC7822
IC302	EI-344764	IC M5218P-21
J301	EJ-368241	PIN J T6228 8P W/SHIELD [PHONO/TUNER/TAPE]
J302	EJ-366329	PIN J T5813 P 6P [AUX/DAT]
R317	ER-378518J	R CB H S10 FS RDS 1/4W 151J
R318	ER-378518J	R CB H S10 FS RDS 1/4W 151J
TR301	ET-354415	TR DTA144ES
TR302	ET-348898	TR FET 2SJ40 C.D.E F05

12. JACK P.C BOARD

Ref. No.	Part No.	Description
J501	EJ-368243	PIN J T6030 2P W/LR SW [CD]
J502	EJ-368243	PIN J T6030 2P W/LR SW [DAT PLAY]

13. PROCESSOR P.C BOARD

Ref. No.	Part No.	Description
J601	EJ-368244	PIN J T6087 8P [PROCESSOR IN/OUT]

14. VOLUME P.C BOARD

Ref. No.	Part No.	Description
D701	ED-338333	D ZENER H HZ5 B2
FR701	*ER-345751	R FUZE H S10 ERD2FC 1/4W 15R0G
IC701	EI-353421	IC BA6229
VR701	EV-368245	VR SPL RK16312MA [VOLUME]

15. MUTE P.C BOARD

Ref. No.	Part No.	Description
D12	ED-376938	D LED SLR56VC 3F RED [MUTING]
TS9	ES-349474	SW TACT SKHHAM004A [MUTING]

16. LED P.C BOARD

Ref. No.	Part No.	Description
D13	ED-368248	D LED SLB-221PVW RED&GREEN [POWER & PROTECTION]

17. REMOTE P.C BOARD

Ref. No.	Part No.	Description
D801	ED-360409	D PHOTO PN323B
IC801	EI-367271	IC UPC1490HA

18. D/A P.C BOARD

Ref. No.	Part No.	Description
D1	ED-344280	D SILICON H GMA-01-FY2 F05
D2	ED-344280	D SILICON H GMA-01-FY2 F05
D3	ED-301911	D SILICON H DS448
D4	ED-344280	D SILICON H GMA-01-FY2 F05
FL1	EH-368606	FILTER LC LP BL-21SR 20KHZ
IC1	EI-368253	IC CXD1076
IC2	EI-368254	IC SN74LS624
IC3	EI-360038	IC TC74HC02P
IC4	EI-365098	IC TC74HC123P
IC5	EI-375346	IC MM74HC04N
IC6	EI-368255	IC TC74HC112
IC7	EI-360027	IC TC74HC86P
IC8	EI-362973	IC AK-80
IC9	EI-368612	IC PCM56P
IC10	EI-332259	IC TC4052BP
IC11	EI-362588	IC M5238P
IC12	EI-362588	IC M5238P
L1	EO-345909	COIL FIX 1 LAL03KH 4R7K
TR1	ET-348898	TR FET 2SJ40 C.D.E F05
TR2	ET-336869	TR 2SC2999 C.D
TR3	ET-336869	TR 2SC2999 C.D
TR4	ET-336869	TR 2SC2999 C.D
TR5	ET-308472	TR 2SA1115 E,F,G F05
TR6	ET-349592	TR 2SC3400 F05
TR7	ET-308472	TR 2SA1115 E,F,G F05
TR8	ET-354897	TR FET 2SK170 BL.GR.V
TR9	ET-308141	TR 2SC2603 G F05
TR10	ET-349081	TR 2SC3383 S,T
TR11	ET-354365	TR DTC114YS
VR1	EV-337992	R S-FIX H RVF8P01 0.10W 502
VR2	EV-337992	R S-FIX H RVF8P01 0.10W 502
VR3	EV-337861	R S-FIX H RVF8P01 0.10W 302
VR4	EV-337996	R S-FIX H RVF8P01 0.10W 104

19. DIGITAL SELECT P.C BOARD

Ref. No.	Part No.	Description
IC101	EI-360040	IC TC74HCU04P
IC102	EI-360038	IC TC74HC02P
IC103	EJ-368258	SOCKET OPTICAL TORX172 [CD OPTICAL]
IC104	EJ-368258	SOCKET OPTICAL TORX172 [DAT OPTICAL]
J101	EJ-368259	PIN J RA B TYPE GP W/SW 1P [CD COAXIAL]
J102	EJ-368259	PIN J RA B TYPE GP W/SW 1P [DAT OPTICAL]
J103	EJ-368260	PIN J RA B TYPE GP WO/SW 1P [DIGITAL OUT COAXIAL]
L101	EO-345922	COIL FIX 1 LAL03KH 470K
L102	EO-345922	COIL FIX 1 LAL03KH 470K
T101	BT-368261	TRANS PULSE TC-1027-04

FINAL ASSEMBLY BLOCK

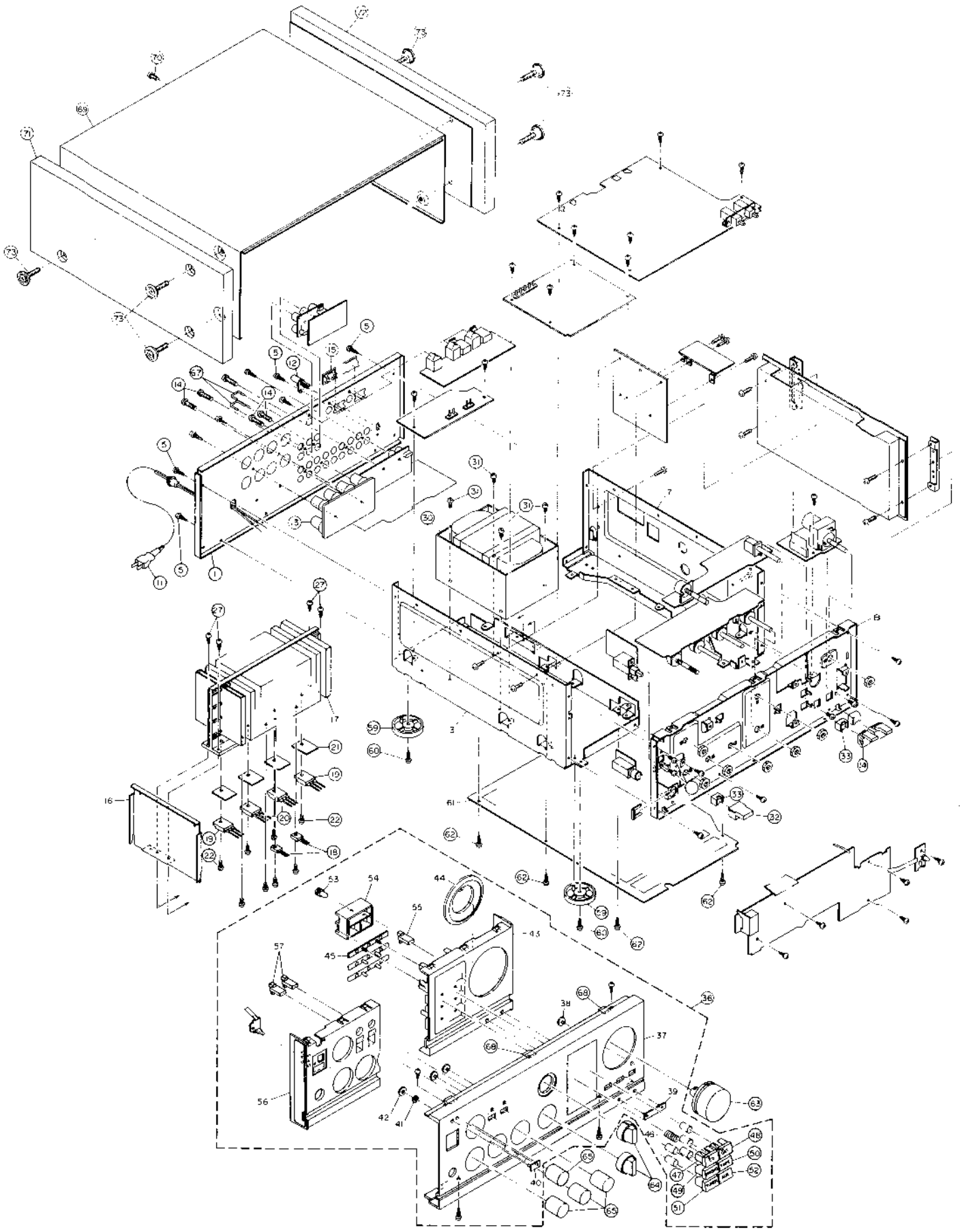

PARTS LIST

20. FINAL ASSEMBLY BLOCK

Ref. No.	Part No.	Description
1A	SP-376986J1	PANEL REAR AM-M939(E.V)
1B	SP-376967J1	PANEL REAR AM-M939(B,S)
4	ZS-308846	T2BR30X08STL BZN PROJECTION
5	ZS-308846	T2BR30X08STL BZN PROJECTION
6	ZS-348375	ST BR30X08STL CMT
9	ZS-422076	PAN30X05STL CMT
10	ZS-336351	T2BR30X08STL NI3
11A	*EW-363672	AC CORD 200 0364 LCFL B070 A EV [E.V]
11B	*EW-363684	AC CORD 200 LCFL B070 A B [B]
12	EJ-329610	TERMINAL W/SCREW UB-0067 L 1P
13A	EJ-337406	TERMINAL W/SCREW ANB-024-AAABP [E,B]
13B	EJ-342935	TERMINAL W/SCREW YKD31-0132P8P [V]
14	ZS-351886	PT BR30X10STL BNI
15	SE-375348	ESLUTCHEON
18	*ET-368251	TR 2SC3964 [TR901]
19	*ET-368760	TR 2SC3855 P.Y [TR902]
20	*ET-368758	TR 2SA1491 P.Y [TR903]
21	EZ-345459	TRANSISTOR SUPPORT BFG-20T0-3P
22	ZS-419670	PAN30X12STL CMT
24	EZ-380254J	TRANSISTOR SUPPORT *****
25	ZS-421806	PAN30X08STL CMT
26	ZS-331567	T2BR30X08STL CMT C080
27	ZS-523664	T2BR30X10STL CMT
28	ZS-350934	PT BR30X08STL BNI
29	EC-332102	C CE V F 473Z 50DC
30A	*BT-368202	TRANS POW A2054-E.V [E.V]
30B	*BT-368203	TRANS POW A2054-B [B]
31	ZS-345624	ST PAN40X08STL CMT CUP
32-G	SK-374631A	KNOB POW G
32-B	SK-374631B	KNOB POW B
33	ZW-368205	FLEXIBLE RING 2414-0-0-086-01
34-G	SK-374632A	KNOB LOUDNESS G
34-B	SK-374632B	KNOB LOUDNESS B
35	ZW-368205	FLEXIBLE RING 2414-0-0-086-01
36-G	BD-A2054A080B	PANEL FRONT BLK AM-M939-G
36-B	BD-A2054A060A	PANEL FRONT BLK AM-M939-B
39	SM-368416B	NAME PLATE DIGITAL(1) B
40-G	SM-370750B-A	NAME PLATE AKAI-G
40-B	SM-370750C	NAME PLATE AKAI B2
41	ZW-273802	TW30
42	ZW-653163	RING CS 280STL PKR
46	ZG-374626	SP PUSH INPUT
47-G	SK-B374630A1	KNOB INPOT CD G PART
47-B	SK-B374630B1	KNOB INPOT CD B PART
48-G	SK-B374630A2	KNOB INPUT DAT G PART
48-B	SK-B374630B2	KNOB INPUT DAT B PART
49-G	SK-B374630A3	KNOB INPUT PHONO G PART
49-B	SK-B374630B3	KNOB INPUT PHONO B PART
50-G	SK-B374630A4	KNOB INPUT TAPE G PART
50-B	SK-B374630B4	KNOB INPUT TAPE B PART
51-G	SK-B374630A5	KNOB INPUT TUNER G PART
51-B	SK-B374630B5	KNOB INPUT TUNER B PART
52-G	SK-B374630A6	KNOB INPUT AUX G PART
52-B	SK-B374630B6	KNOB INPUT AUX B PART
53	BT-368263	COLOR CAP EQ300-42000A BB2-501
55-G	SK-374633A	KNOB MUTE G
55-B	SK-374633B	KNOB MUTE B
57-G	SK-374633A	KNOB MUTE G
57-B	SK-374633B	KNOB MUTE B
58	ZS-463353	T2BR30X08STL BNI
59	SA-B370709	FOOT PART
60	ZS-331567	T2BR30X08STL CMT C080
62	ZS-463353	T2BR30X08STL BNI
63-G	SK-374642A	KNOB VR G
63-B	SK-374642B	KNOB VR B
64-G	SK-374629A	KNOB SELECTOR G

Ref. No.	Part No.	Description
64-B	SK-374629B	KNOB SELECTOR B
65-G	SK-374628A	KNOB TONE G
65-B	SK-374628B	KNOB TONE B
66	MZ-553948	WIRE BAND F-100
67	EJ-369015	PLUG SHORT-PIN CNT31-0057
68	ZZ-378453	CUSHION
69-G	SP-374620A	COVER UPPER G
69-B	SP-374620B	COVER UPPER B
70	ZS-308846	T2BR30X08STL BZN PROJECTION
71	SP-370711	SIDE BOARD (L)
72	SP-370712	SIDE BOARD (R)
73	ZS-365678	SCREW SLIDE TYPE W/WASHER(J)

SYMBOL FOR COLOR VARIATION

B : BLACK
G : GOLD

NOTE: Parts will not be supplied if they are not listed in the parts list, even if they appear on the assembling illustrations with reference No.

21. ACCESSARY

Ref. No.	Part No.	Description
1	AX-368204	REMOCON RC-S930 WIRELESS (T)

INDEX

Part No.	Ref. No.	Part No.	Ref. No.	Part No.	Ref. No.	Part No.	Ref. No.
AX-368204	1	ED-360409	D801	EJ-368243	J501	ES-368237	SW201
BA-A2054A020B	1A	ED-368225	13	EJ-368243	J502	ET-308141	80
BA-A2054A020C	1B	ED-368225	D15	EJ-368244	J601	ET-308141	TR9
BA-A2054A030A	2A	ED-368248	4	ET-368258	50	ET-308472	72
BA-A2054A030B	2B	ED-368248	D13	EJ-368258	IC103	ET-308472	TR5
BA-A2054A040A	3	ED-376938	6	EJ-368258	IC104	ET-308472	TR7
BD-A2054A060A	36-B	ED-376938	D12	EJ-368259	J101	ET-310148	93
BD-A2054A060B	36-G	ED-376939	5	EJ-368259	J102	ET-310148	TR110
BT-368202	2	ED-376939	D4	EJ-368260	J103	ET-321016	69
BT-368202	30A	ED-376939	D5	EJ-369015	67	ET-321016	TR1
BT-368203	1	ED-376939	D6	EJ-369995	J401	ET-321596	92
BT-368203	30B	ED-376939	D7	EL-368264	51	ET-321596	TR107
BT-368261	3	ED-376939	D8	EL-368264	IN101	ET-327714	79
BT-368261	T101	ED-376939	D9	EL-368264	IN102	ET-327714	TR108
BT-368263	53	ED-376939	D10	EO-332116	L1	ET-336869	84
EC-326583	C18	ED-376939	D11	EO-338409	52	ET-336869	TR2
EC-332102	29	ED-378503J	14	EO-338409	LV201	ET-336869	TR3
EC-338496	C301	ED-378503J	D115	EO-345909	L1	ET-336869	TR4
EC-355461	C10	ED-378503J	D116	EO-345922	L101	ET-337759	71
EC-368222	C5	EF-358974	27	EO-345922	L102	ET-337759	TR101
EC-368222	C6	EF-358974	F3B	EQ-337159	53	ET-337759	TR102
ED-301911	10	EF-358974	F4B	EQ-337159	RL1	ET-337759	TR105
ED-301911	D8	EF-358974	F5B	EQ-337159	RL2	ET-337759	TR106
ED-301911	D9	EF-364518	26	EQ-344440-A	54	ET-337759	TR109
ED-301911	D10	EF-364518	F1B	EQ-344440-A	RL101	ET-337759	TR111
ED-301911	D11	EF-601942	29	ER-345751	56	ET-337759	TR113
ED-301911	D12	EF-601942	F3A	ER-345751	FR701	ET-337759	TR115
ED-301911	D1	EF-601942	F4A	ER-355214	R105	ET-338244	73
ED-301911	D2	EF-601942	F5A	ER-364696	R112	ET-338244	TR11
ED-301911	D3	EF-623125	28	ER-368228	R39	ET-338410	81
ED-301911	D14	EF-623125	F1A	ER-368282	R6	ET-338410	TR104
ED-301911	D15	EH-368606	30	ER-368282	R7	ET-345625	85
ED-301911	D101	EH-368606	FL1	ER-368282	R57	ET-345625	TR103
ED-301911	D3	EI-332259	42	ER-368285	R40	ET-345626	75
ED-330219	18	EI-332259	IC10	ER-368285	R41	ET-345626	TR104
ED-330219	D1	EI-344764	38	ER-368286	R110	ET-348829	74
ED-330219	D2	EI-344764	IC302	ER-368286	R111	ET-348829	TR3
ED-330319	8	EI-345474	34	ER-372990	R35	ET-348829	TR7
ED-330319	D113	EI-345474	IC2	ER-372990	R36	ET-348829	TR9
ED-337990	20	EI-349372	49	ER-375106	R17	ET-348830	82
ED-337990	D101	EI-349372	X1	ER-375106	R18	ET-348830	TR4
ED-337990	D102	EI-353421	IC701	ER-378497J	R24	ET-348830	TR5
ED-337990	D103	EI-360027	47	ER-378497J	R25	ET-348830	TR10
ED-337990	D104	EI-360027	IC7	ER-378499J	R33	ET-348831	83
ED-338333	21	EI-360038	44	ER-378499J	R34	ET-348831	TR2
ED-338333	D701	EI-360038	IC3	ER-378499J	R107	ET-348831	TR6
ED-343410	22	EI-360038	IC102	ER-378501J	R31	ET-348831	TR8
ED-343410	D3	EI-360040	43	ER-378502J	R32	ET-348898	68
ED-344280	11	EI-360040	IC101	ER-378504J	55	ET-348898	TR302
ED-344280	D117	EI-362588	39	ER-378504J	R103	ET-348898	TR1
ED-344280	D118	EI-362588	IC1	ER-378504J	R104	ET-349081	87
ED-344280	D301	EI-362588	IC11	ER-378504J	R105	ET-349081	TR10
ED-344280	D1	EI-362588	IC12	ER-378504J	R106	ET-349592	88
ED-344280	D2	EI-362973	31	ER-378504J	R108	ET-349592	TR105
ED-344280	D4	EI-362973	IC8	ER-378504J	R109	ET-349592	TR6
ED-346525	23	EI-365098	46	ER-378504J	R112	ET-349593	77
ED-346525	D114	EI-365098	IC4	ER-378517J	R401	ET-349593	TR106
ED-346528	24	EI-367271	48	ER-378518J	R317	ET-353899	76
ED-346528	D107	EI-367271	IC801	ER-378518J	R318	ET-353899	TR8
ED-346528	D108	EI-368231	35	ER-378608J	R10	ET-354094	66
ED-346532	25	EI-368231	IC1	ER-378608J	R11	ET-354094	TR4
ED-346532	D111	EI-368240	36	ER-378643J	R22	ET-354365	64
ED-346554	15	EI-368240	IC301	ER-378643J	R23	ET-354365	TR2
ED-346554	D4	EI-368253	33	ES-349474	61	ET-354365	TR5
ED-346554	D5	EI-368253	IC1	ES-349474	TS1	ET-354365	TR6
ED-346567	16	EI-368254	41	ES-349474	TS2	ET-354365	TR7
ED-346567	D105	EI-368254	IC2	ES-349474	TS3	ET-354365	TR11
ED-346567	D106	EI-368255	45	ES-349474	TS4	ET-354371	65
ED-346571	17	EI-368255	IC6	ES-349474	TS5	ET-354371	TR16
ED-346571	D109	EI-368812	40	ES-349474	TS6	ET-354415	62
ED-346576	19	EI-368812	IC9	ES-349474	TS7	ET-354415	TR301
ED-346576	D110	EI-373980	32	ES-349474	TS8	ET-354897	70
ED-348786	12	EI-373980	IC201	ES-349474	TS9	ET-354897	TR8
ED-348786	D112	EI-375346	37	ES-361970	57	ET-360067	86
ED-348990	9	EI-375346	IC5	ES-361970	SW301	ET-360067	TR1
ED-348990	D6	EJ-329610	12	ES-368227	58	ET-360399	63
ED-348990	D7	EJ-337406	13A	ES-368227	SW1	ET-360399	TR3
ED-348990	D13	EJ-342935	13B	ES-368236	60	ET-360399	TR9
ED-348990	D14	EJ-366329	J302	ES-368236	SW101	ET-360399	TR12
ED-360409	7	EJ-368241	J301	ES-368237	59	ET-360399	TR13

INDEX

Part No.	Ref. No.	Part No.	Ref. No.	Part No.	Ref. No.	Part No.	Ref. No.
ET-360399	TR14	ZS-308846	70				
ET-360399	TR15	ZS-331567	26				
ET-362113	91	ZS-331567	60				
ET-362113	TR112	ZS-336351	10				
ET-362113	TR114	ZS-345624	31				
ET-362113	TR116	ZS-348375	6				
ET-368249	67	ZS-350934	28				
ET-368249	TR10	ZS-351886	14				
ET-368249	TR11	ZS-365678	73				
ET-368249	TR101	ZS-419670	22				
ET-368249	TR102	ZS-421806	25				
ET-368249	TR103	ZS-422076	9				
ET-368251	90	ZS-463353	58				
ET-368251	18	ZS-463353	62				
ET-368758	78	ZS-523664	27				
ET-368758	20	ZW-273802	41				
ET-368760	89	ZW-368205	33				
ET-368760	19	ZW-368205	35				
EV-337861	VR3	ZW-653163	42				
EV-337992	VR1	ZZ-378453	68				
EV-337992	VR2						
EV-337996	VR4						
EV-355457	95						
EV-355467	VR202						
EV-355466	96						
EV-355466	VR201						
EV-368235	97						
EV-368235	VR101						
EV-368245	98						
EV-368245	VR701						
EV-368268	94						
EV-368268	VR203						
EV-380204	VR1						
EW-363672	11A						
EW-363684	11B						
EZ-345459	21						
EZ-358816	99						
EZ-358816	BT1						
EZ-380254J	24						
MZ-553948	66						
SA-B370709	59						
SE-375348	15						
SK-B374630A1	47-G						
SK-B374630A2	48-G						
SK-B374630A3	49-G						
SK-B374630A4	50-G						
SK-B374630A5	51-G						
SK-B374630A6	52-G						
SK-B374630B1	47-B						
SK-B374630B2	48-B						
SK-B374630B3	49-B						
SK-B374630B4	50-B						
SK-B374630B5	51-B						
SK-B374630B6	52-B						
SK-374628A	65-G						
SK-374628B	65-B						
SK-374629A	64-G						
SK-374629B	64-B						
SK-374631A	32-G						
SK-374631B	32-B						
SK-374632A	34-G						
SK-374632B	34-B						
SK-374633A	55-G						
SK-374633A	57-G						
SK-374633B	55-B						
SK-374633B	57-B						
SK-374642A	63-G						
SK-374642B	63-B						
SM-3684168	39						
SM-370750B-A	40-G						
SM-370750C	40-B						
SP-370711	71						
SP-370712	72						
SP-374620A	69-G						
SP-374620B	69-B						
SP-376966J1	1A						
SP-376967J1	1B						
ZG-374626	46						
ZS-308846	4						
ZS-308846	5						

ABBREVIATIONS (AMPLIFIER)

ABBREVIATIONS	EXPLANATION
AC	Alternating Current
AMP	AMPLifier
CD	Compact Disc
DC	Direct Current
GND	GrouND
MC	Moving Coil
MM	Moving Magnet
PCB	Printed Circuit Board
REC	RECOrd
SW	SWitch
V.DISC	Video DISC
VR	Variable Resistance
VTR	Video Tape Recorder

AKAI ELECTRIC CO., LTD.

12-14, 2-Chome, Higashi-Kojiya, Ohta-Ku, Tokyo, Japan

TEL: Tokyo (742) 5111 CABLE: HIFIAKAI TOKYO TELEX: J26261

Printed No.871006-11-0900

Printed Date: October 28, 1987

350 Printed in Japan

AKAI

MODEL AM-M939

SCHEMATIC DIAGRAM AND PC BOARDS

TABLE OF CONTENTS

1. BLOCK DIAGRAM	3
2. CONNECTION DIAGRAM.....	4
3. MAIN AMP PC BOARD AND OTHER PC BOARD.....	5
4. D/A & DIGITAL SELECT SCHEMATIC DIAGRAM.....	6
5. D/A & DIGITAL SELECT PC BOARD.....	7
6. SCHEMATIC DIAGRAM OF ICs.....	8

A B C D E F

D/A PCB A2054A503A

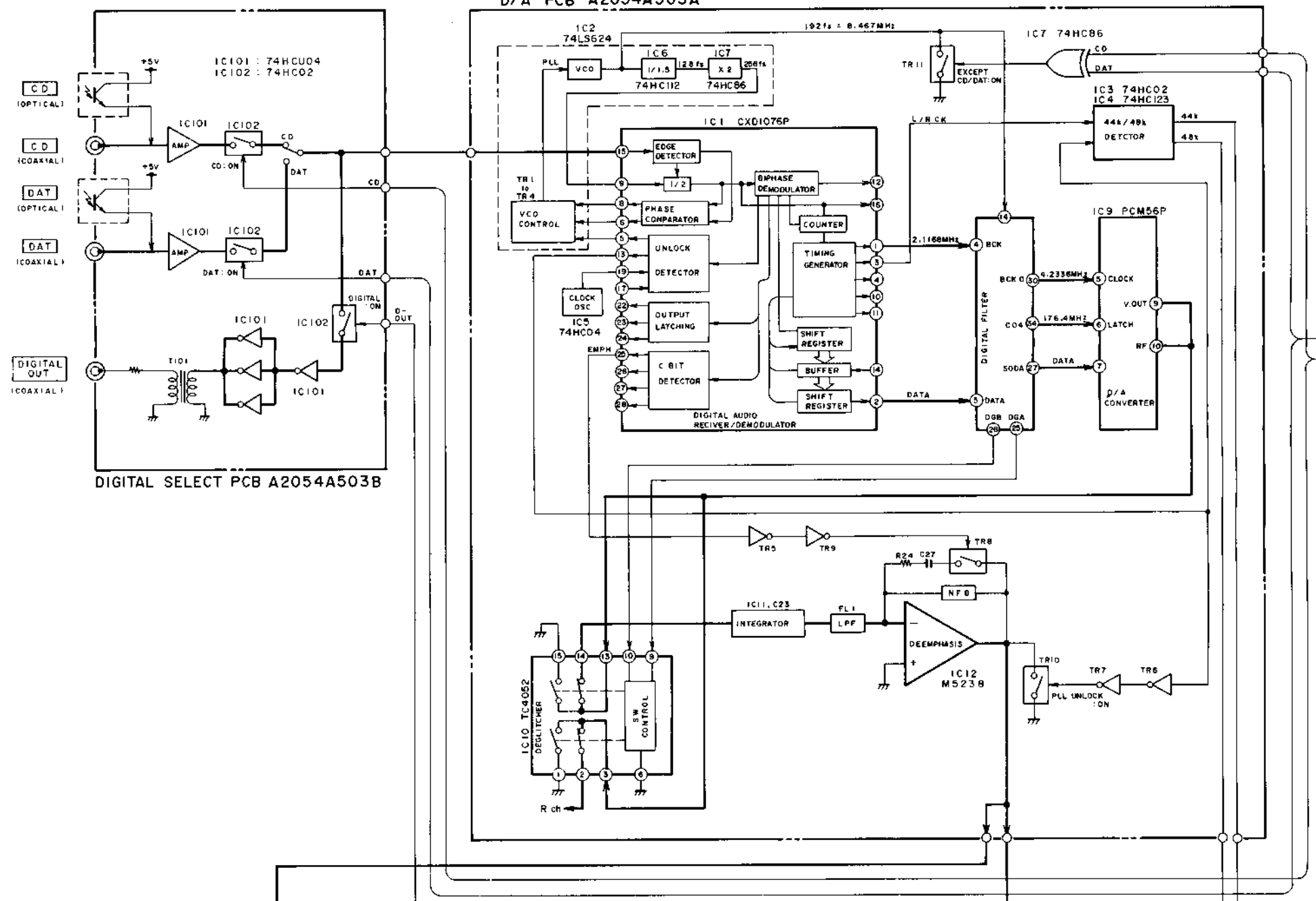

DIGITAL SELECT PCB A2054A503B

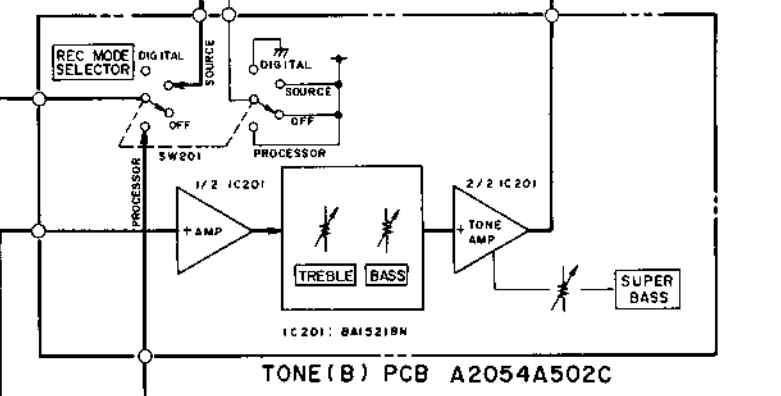
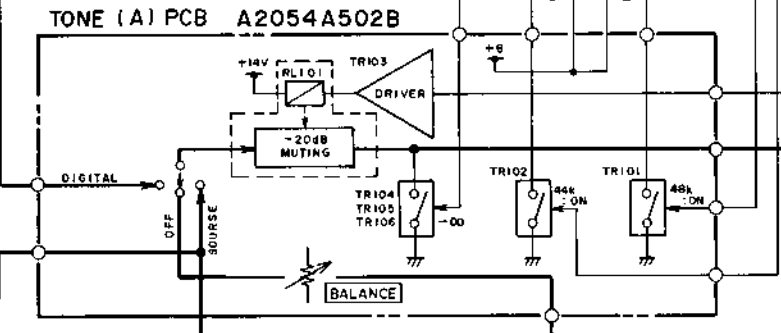
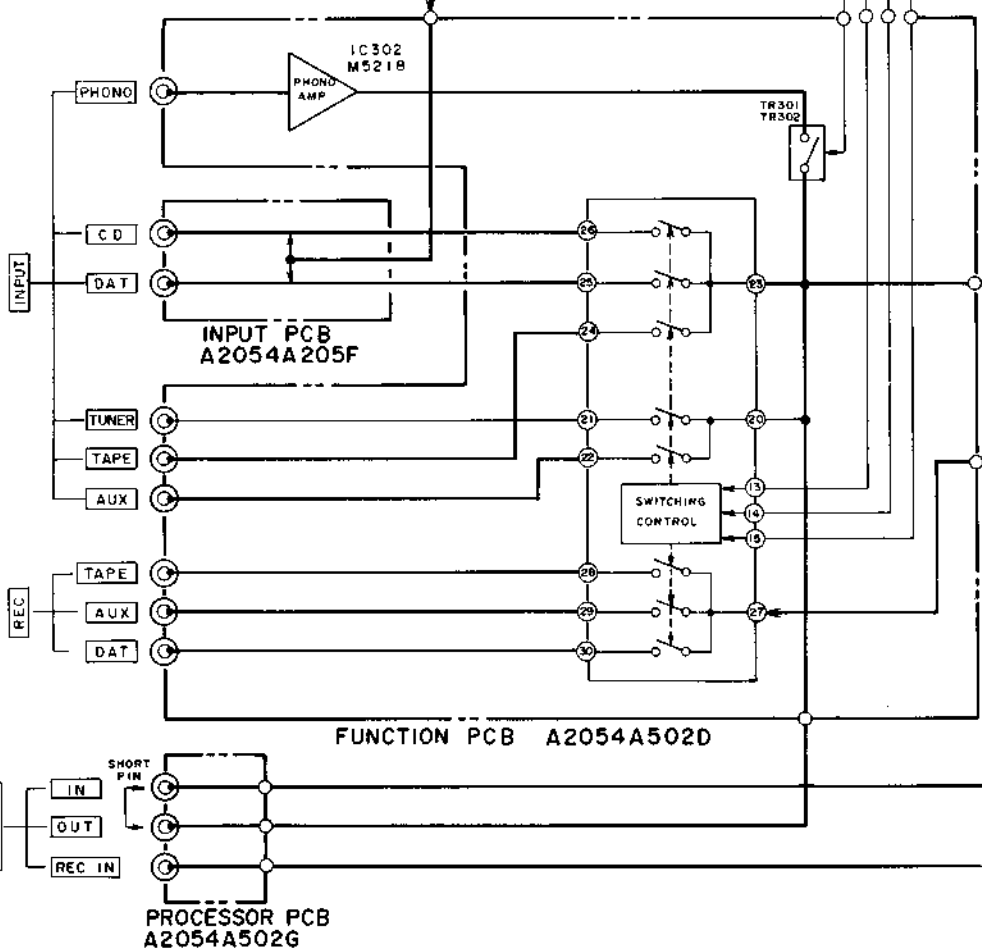
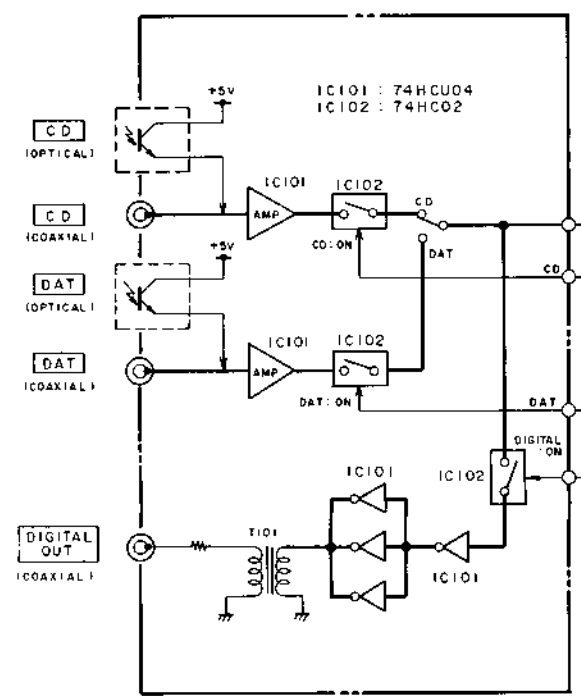

A B C D E F

1
2
3
4
5
6
7
8

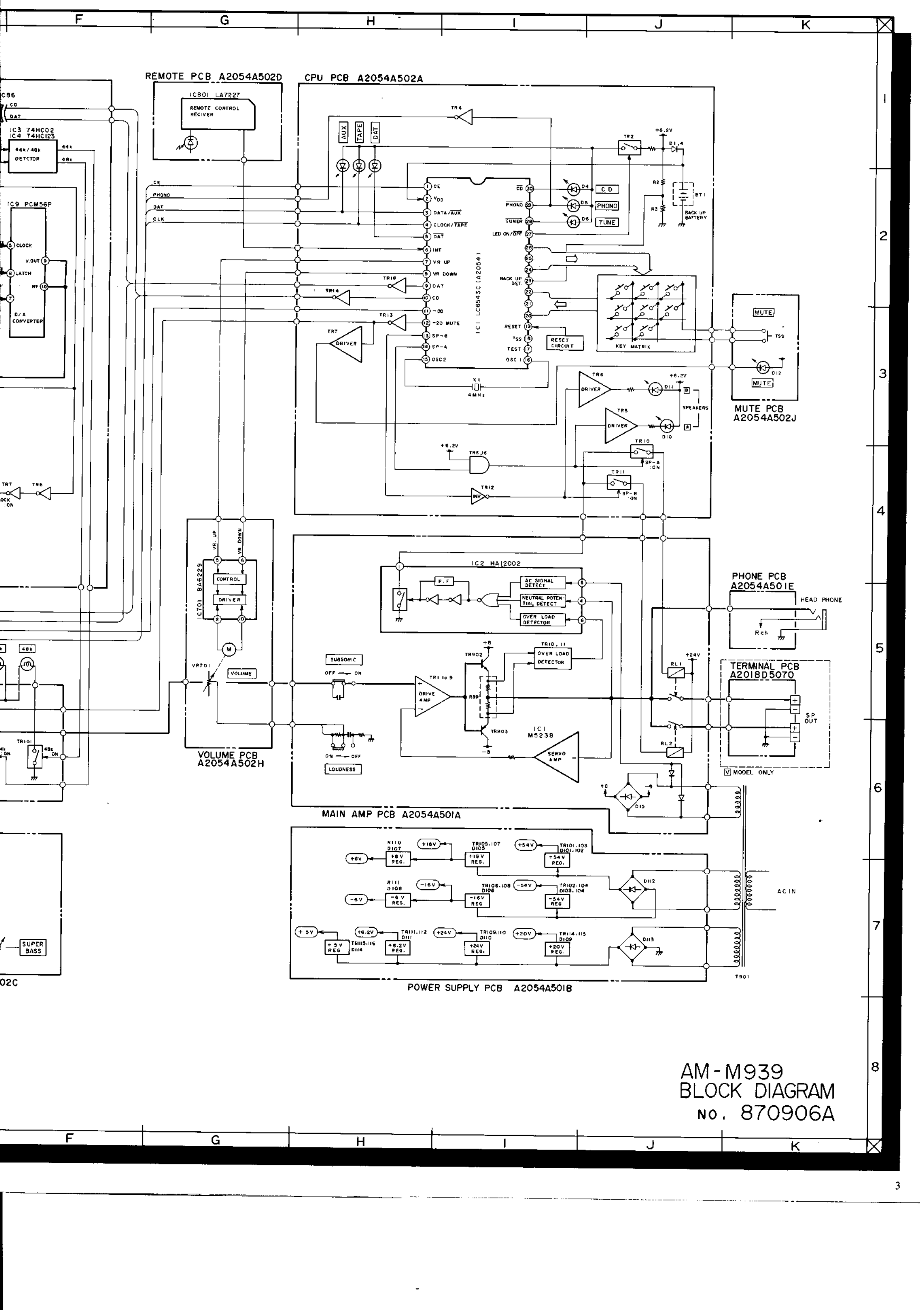

REMOTE PCB A2054A502D

CPU PCB A2054A502A

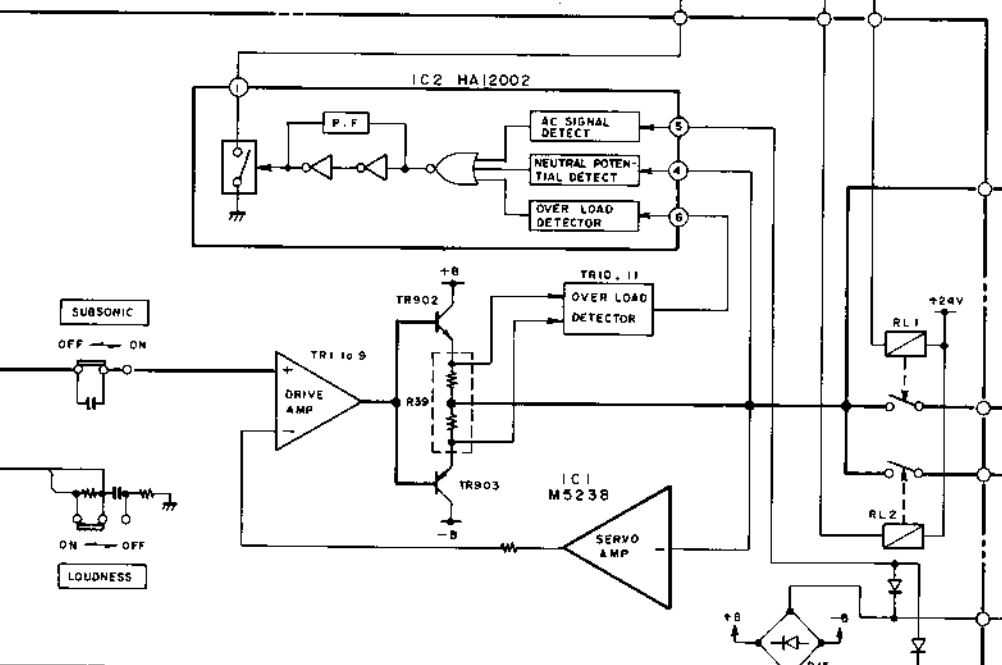
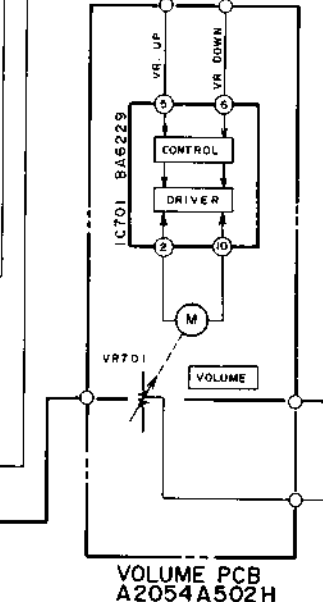
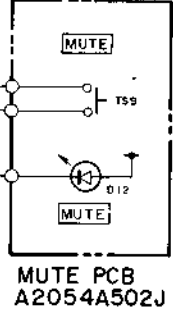
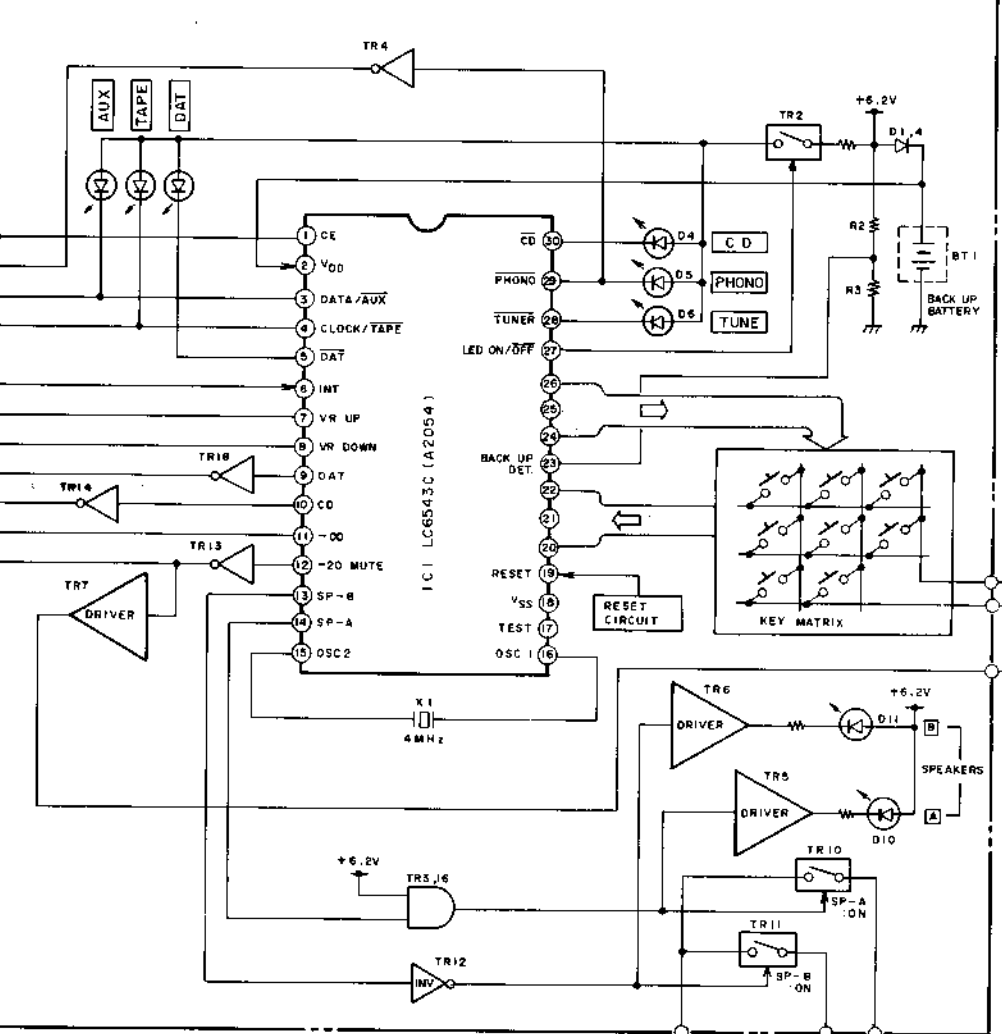
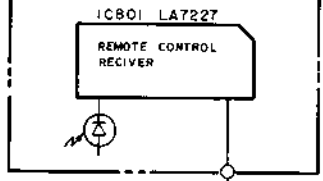

MAIN AMP PCB A2054A501A

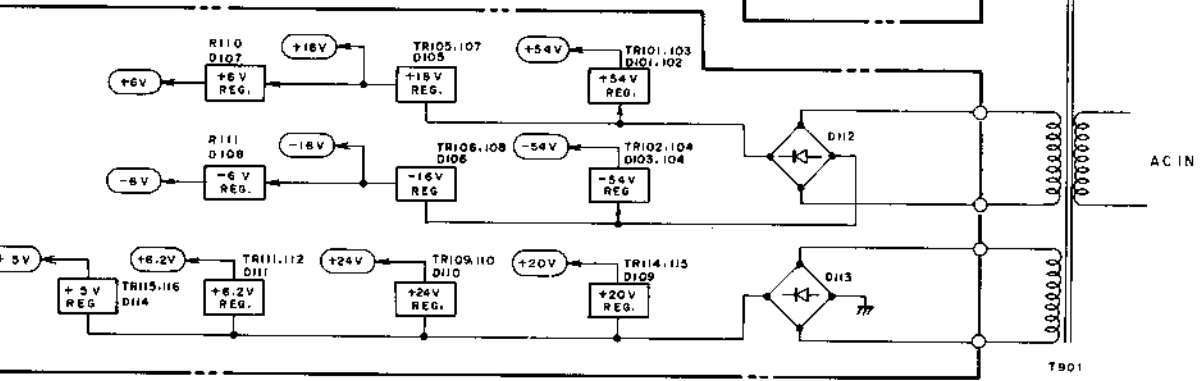

AM-M939
BLOCK DIAGRAM
No. 870906A

1
2
3
4
5
6
7
8

AM-M939

デジタル
セレクト基板
DIGITAL
SELECT PCB
A2054A503B

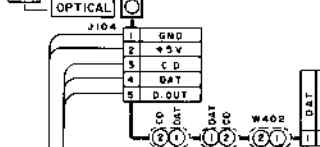

D/A PCB
A2054A503A
D/A基板

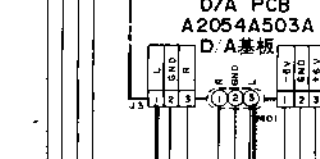

トーン(B)基板
TONE (B) PCB A2054A502C

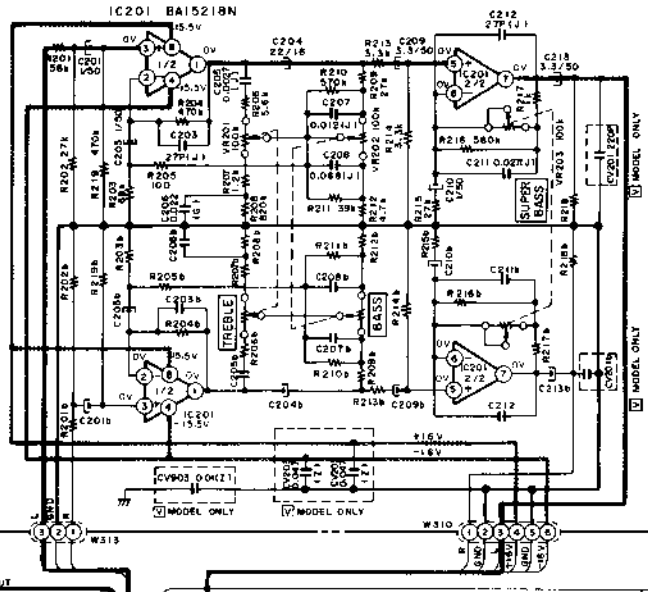

ボリューム基板
VOLUME PCB A2054A502D

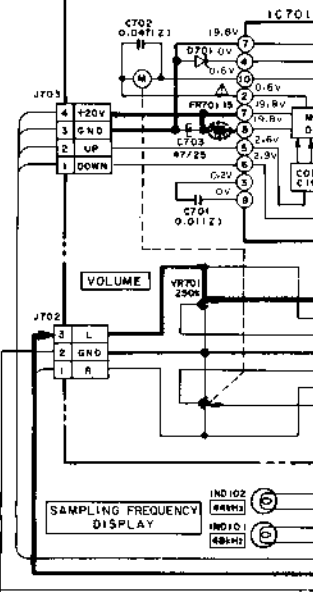

トーン(A)基板
TONE(A) PCB A2054A502B

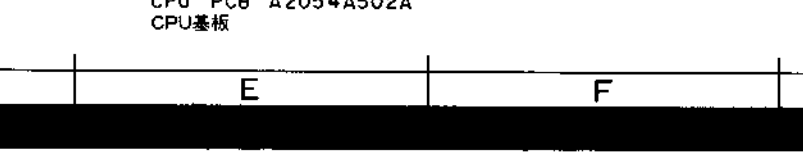
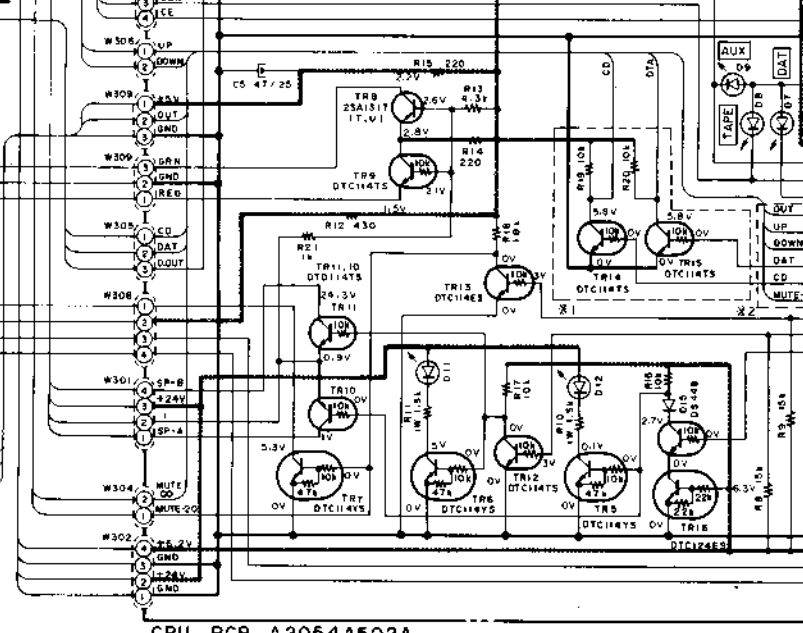
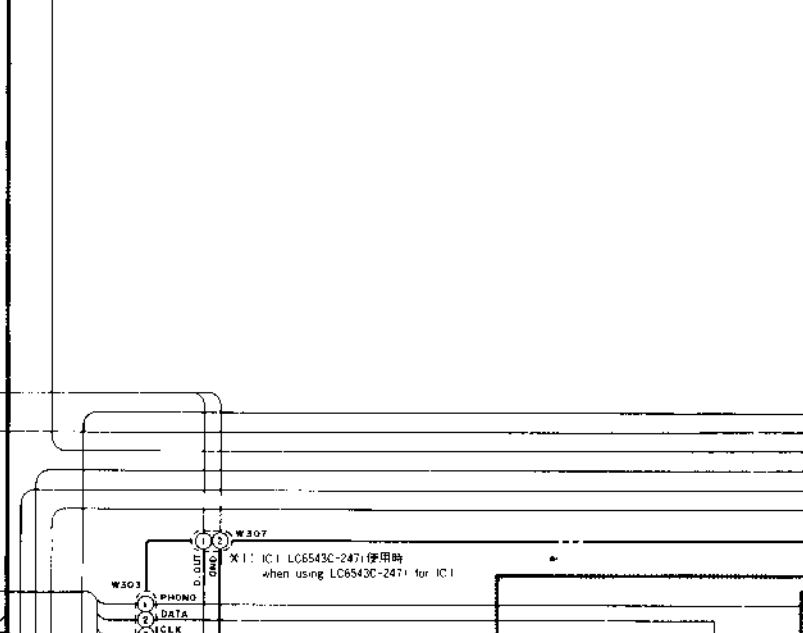
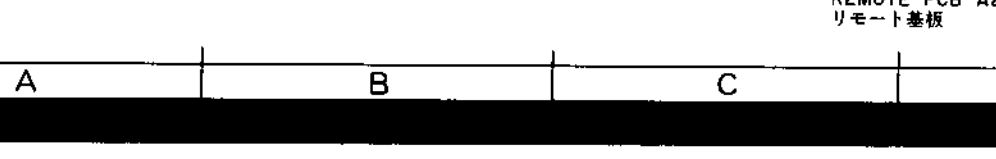
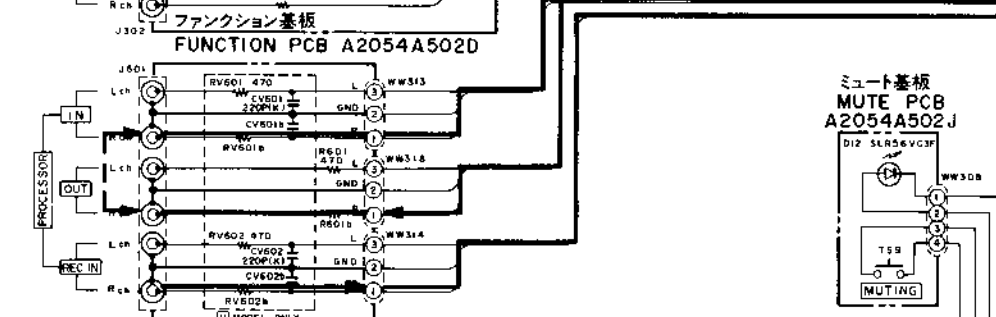
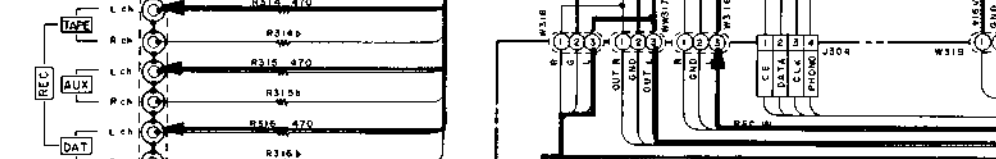
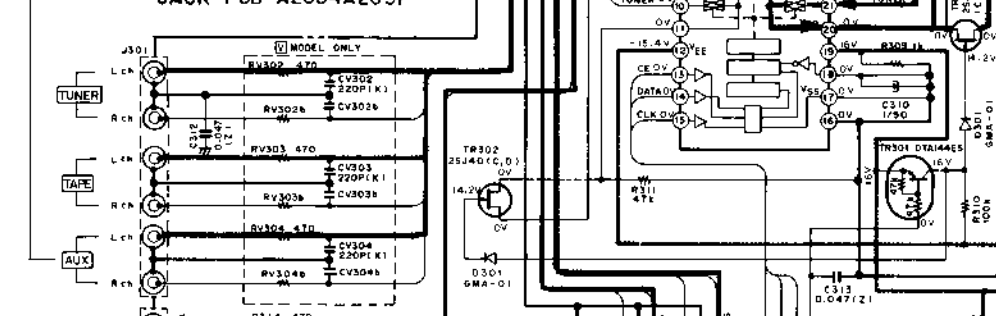
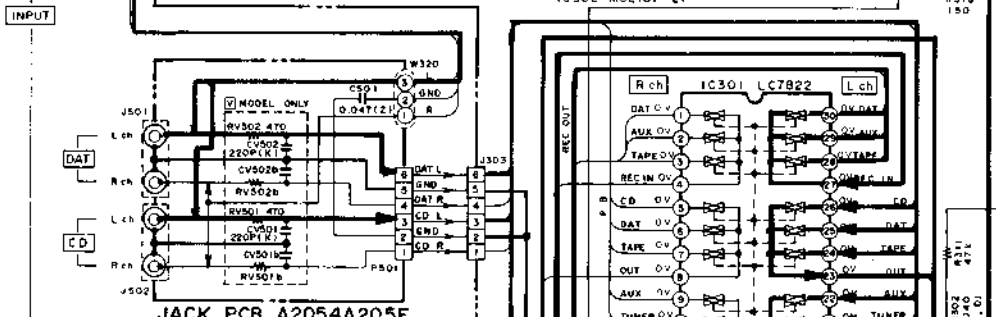
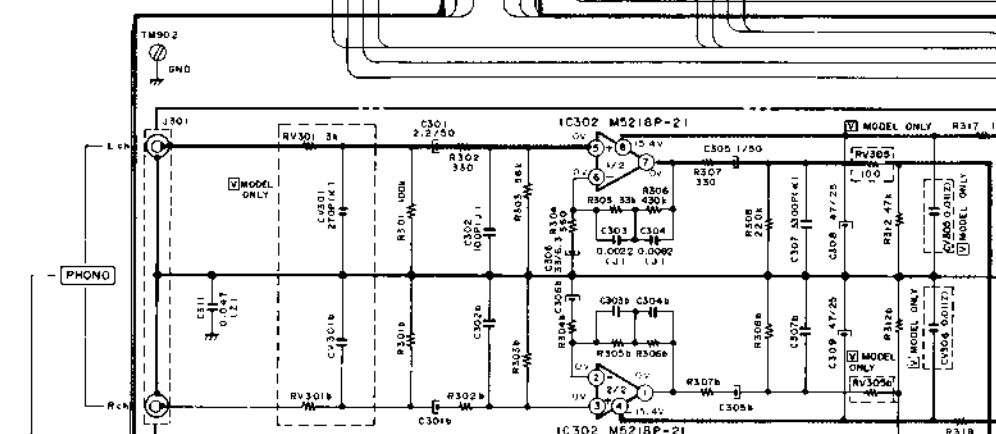
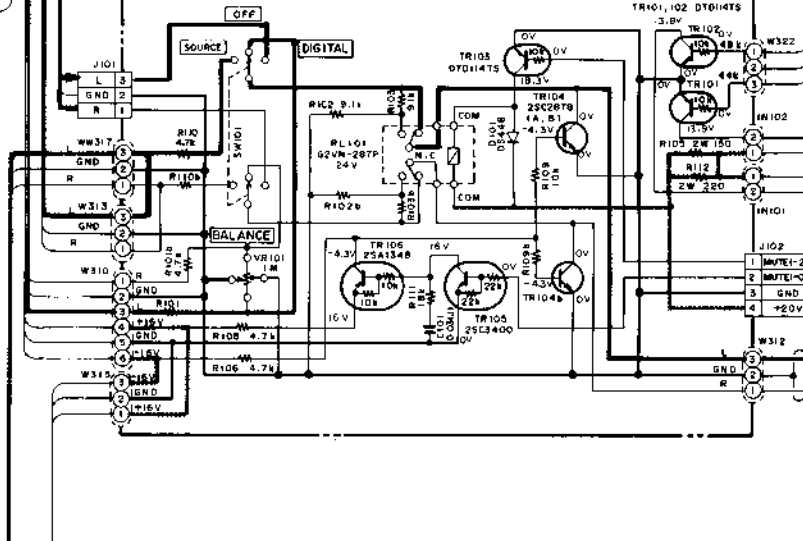

ボリューム基板
VOLUME PCB A2054A502H

メインアンプ基板
MAIN AMP PCB A2054A501A

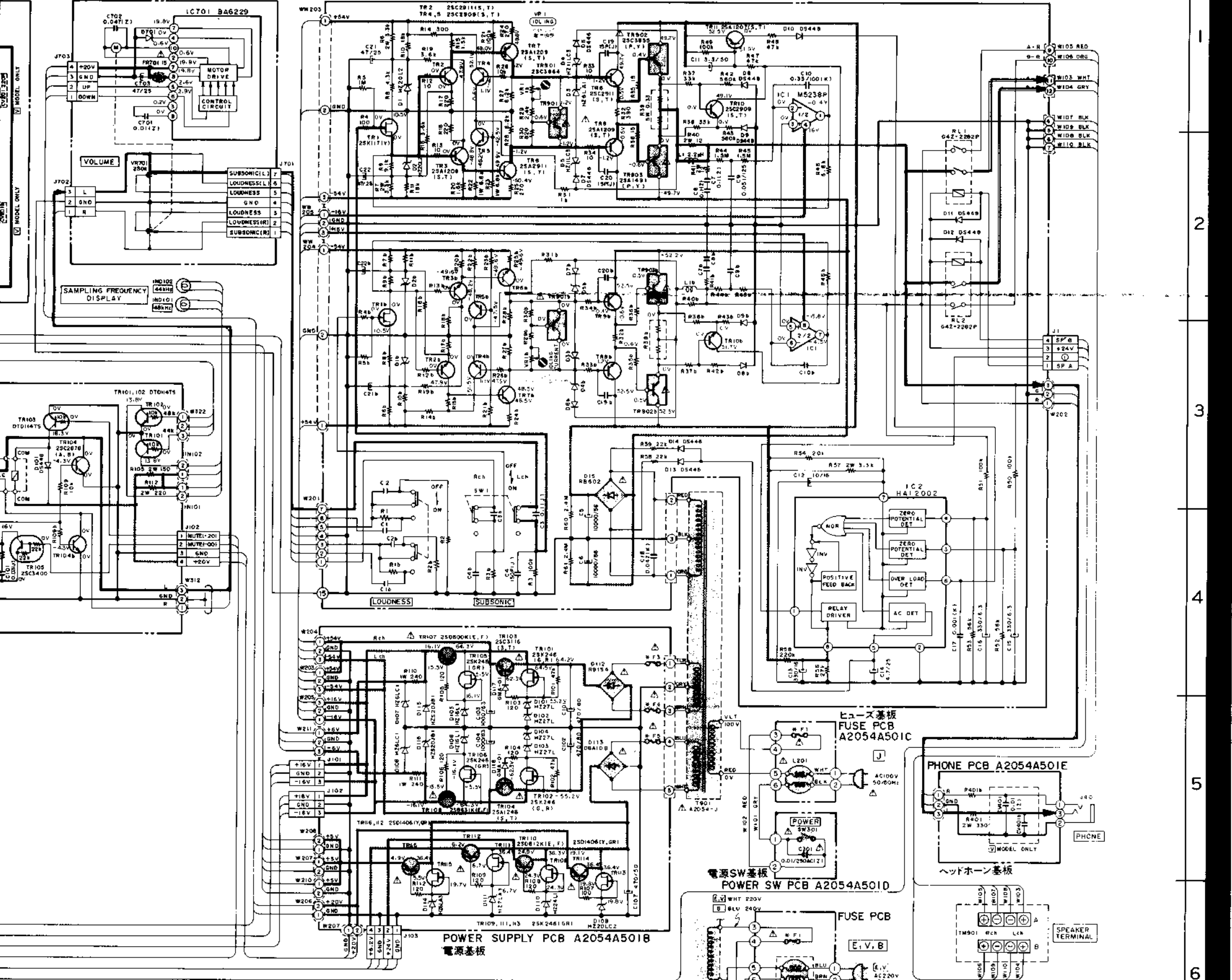

FUSE	DE-U950/R30	AM-M939
F1	6.3A 250V	T2.5A 250V
F3	1.25A 250V	T630MA 250V
F4	1.25A 250V	T630MA 250V
F5	1A 250V	T800MA 250V

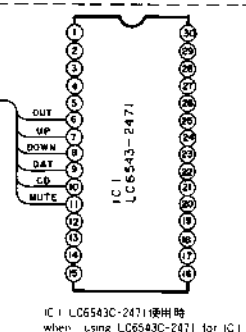

ヒューズ基板
FUSE PCB A2054A501C

電源スイッチ基板
POWER SW PCB A2054A501D

PHONE PCB A2054A501E

ヘッドホン基板

TERMINAL(V) PCB A2018D5070

BIPOWER SUPPLY: LIF
電源3-1

SIGNAL LINE
信号線

NOTE
UNLESS OTHERWISE SPECIFIED,
ALL RESISTORS IN OHMS (1/4W(1))
ALL CAPACITORS IN μF (50V(1))

WARNING: ⚠ AND ⚡ INDICATE SAFETY CRITICAL
COMPONENTS FOR CONTINUED SAFETY.
REPLACE SAFETY CRITICAL COMPONENTS
ONLY WITH MANUFACTURER'S RECOMMENDED PARTS.

AVERTISSEMENT: ⚠ ET ⚡ ILS INDIQUENT LES
COMPOSANTS CRITIQUES DE SÉCURITÉ.
POUR MAINTENIR LE DEGRÉ DE SÉCURITÉ
DE L'APPAREIL, NE REMPLACER QUE DES
PIÈCES RECOMMANDÉES PAR LE
FABRICANT

AM-M939
CONNECTION DIAGRAM
No. 2-1 870907A

REC MODE SELECTOR
DIGITAL ← SOURCE → OFF → PROCESSOR

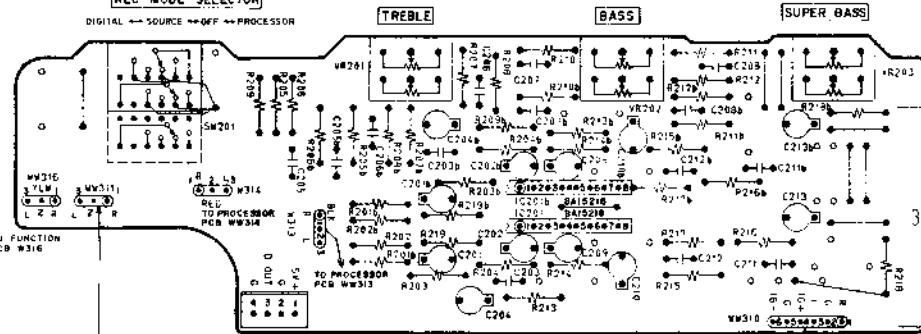

ボリューム基板
VOLUME PCB A2054A502H

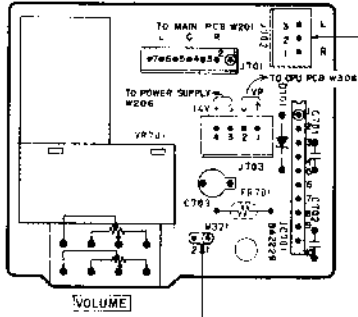

モーター基板
MOTOR PCB A2054A502M

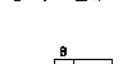

B = NPN TRANSISTOR
 B = PNP TRANSISTOR

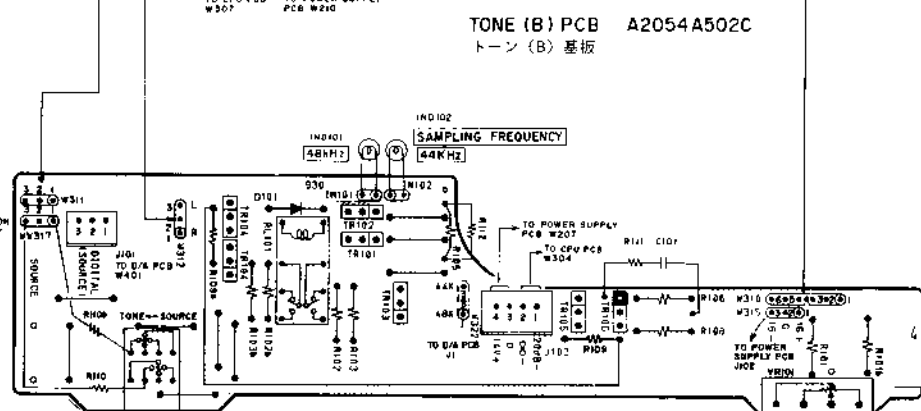

トーン (A) 基板
TONE (A) PCB A2054A502B

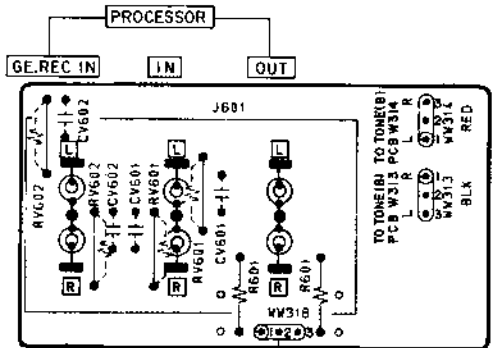

プロセッサー基板
PROCESSOR PCB A2054A502G

ジャック基板
JACK PCB A2054A502F



ファンクション基板
FUNCTION PCB A2054A502D

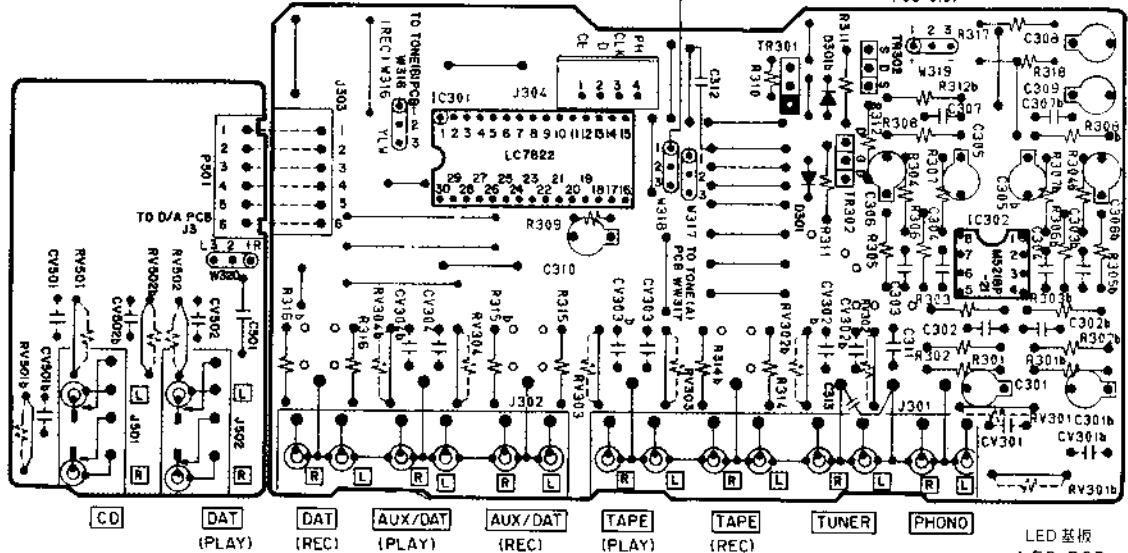

LED 基板
LED PCB A2054A502K

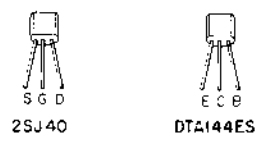

B = NPN TRANSISTOR
 B = FET
 S G D

リモート基板
REMOTE PCB A2054A502L

ミュート基板
MUTE PCB A2054A502J

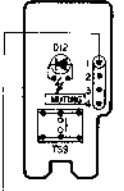

CPU 基板
CPU PCB A2054A502A

B = NPN TRANSISTOR
 B = PNP TRANSISTOR

25C3330
 DT144YS
 DT144WS
 25A1317
 DT124ES

WARNING: INDICATE REPLACEMENT RECOMMENDED
 AVERTISSEMENT: POUR MONTRE NE RECOMMENDÉ

- IC1 ----- B5
- TR1 ----- A4
- TR1b ----- E4
- TR2 ----- A3
- TR2b ----- E3
- TR3 ----- A3
- TR3b ----- E3
- TR4 ----- A3
- TR4b ----- E3
- TR5 ----- A3
- TR5b ----- E3
- TR6 ----- A2
- TR6b ----- D2
- TR7 ----- A2
- TR7b ----- E2
- TR8 ----- A2
- TR8b ----- E2
- TR9 ----- A2
- TR9b ----- D2
- TR10 ----- A1
- TR10b ----- E1
- TR11 ----- D4
- TR901 ----- B1
- TR901b ----- D1
- TR902 ----- A1
- TR902b ----- D1
- TR903 ----- B1
- TR903b ----- C1

- = NPN TRANSISTOR
- = PNP TRANSISTOR
- = FET
- S G D

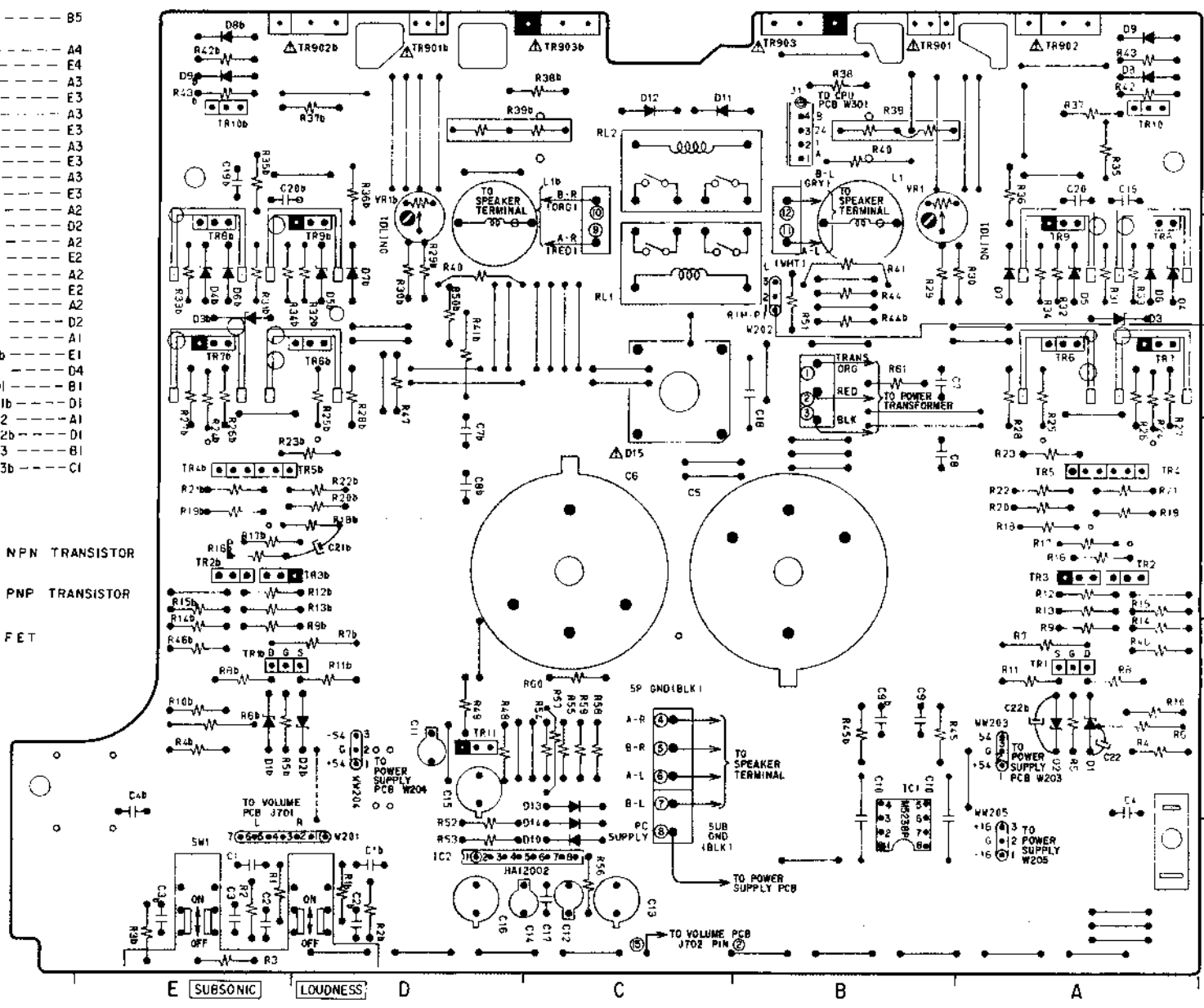

MAIN AMP PCB A2054A501A
メインアンプ基板

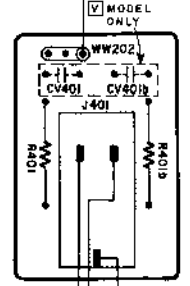
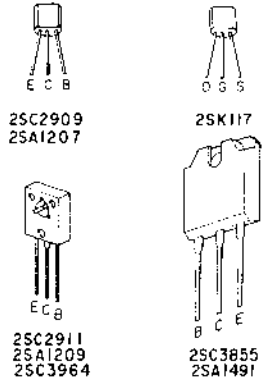

PHONE PCB A2054A501E
ヘッドホーン基板

WARNING: Δ INDICATES SAFETY CRITICAL COMPONENTS. FOR CONTINUED SAFETY, REPLACE SAFETY CRITICAL COMPONENTS ONLY WITH MANUFACTURER'S RECOMMENDED PARTS.

AVERTISSEMENT: Δ IL INDIQUE LES COMPOSANTS CRITIQUES DE SÉCURITÉ. POUR MAINTENIR LE DEGRÉ DE SÉCURITÉ DE L'APPAREIL, NE REMPLACER QUE DES PIÈCES RECOMMANDÉES PAR LE FABRICANT.

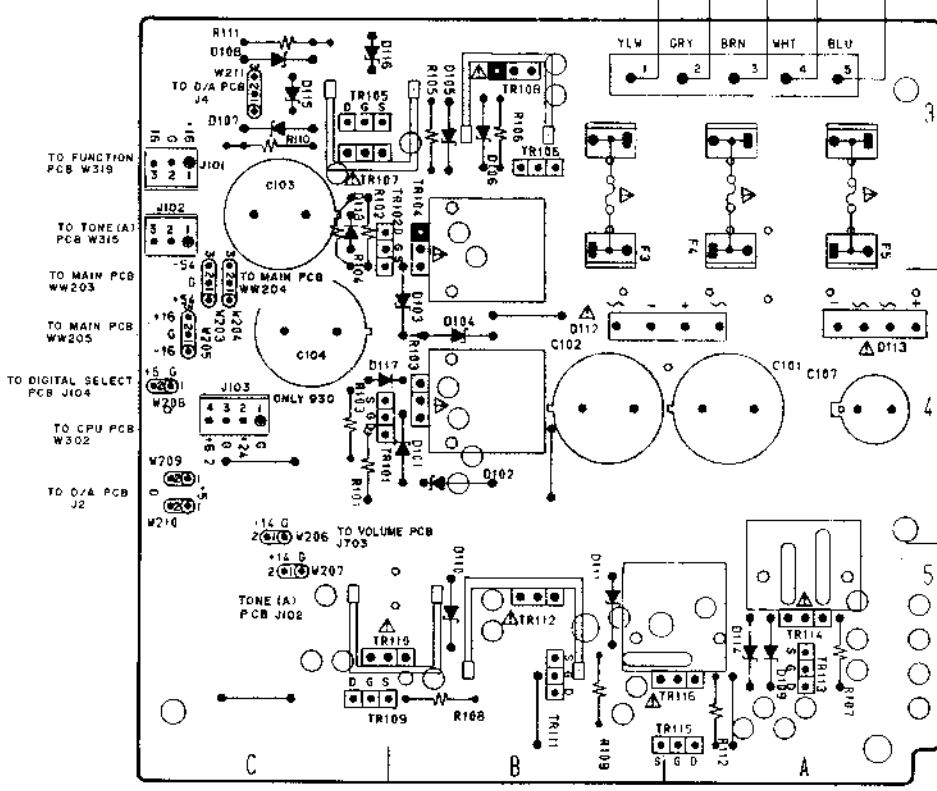

POWER SUPPLY PCB A2054A501B
電源基板

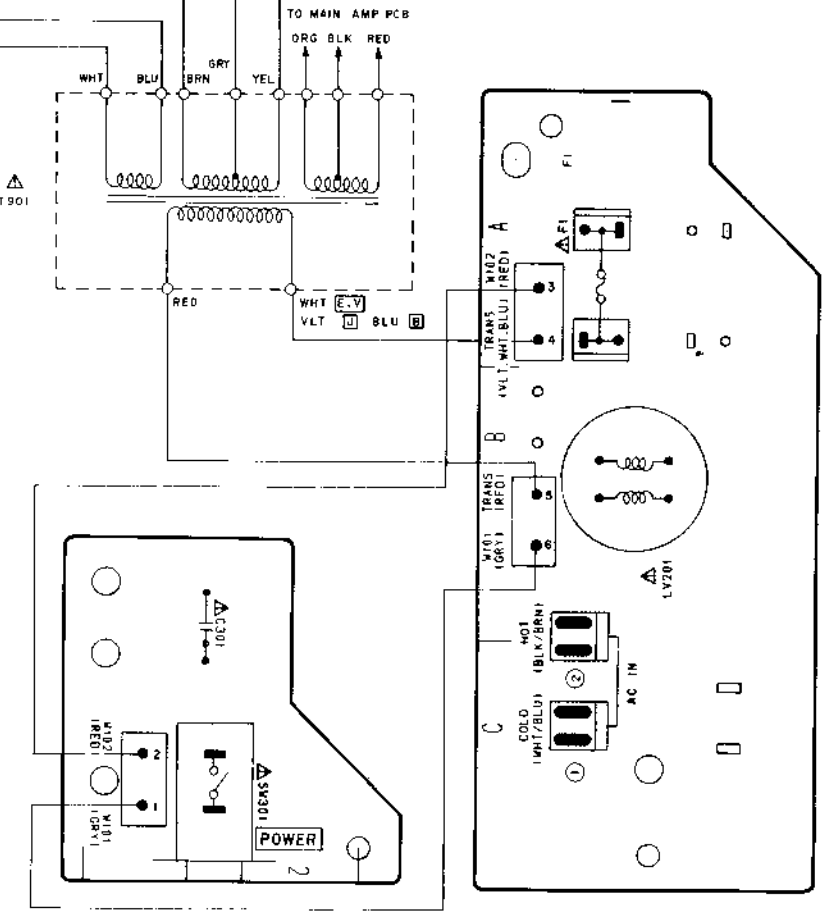

POWER SW PCB A2054A501D
電源スイッチ基板

FUSE PCB A2054A501C
ヒューズ基板

- = NPN TRANSISTOR
- = PNP TRANSISTOR
- = FET
- S G D

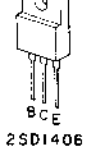
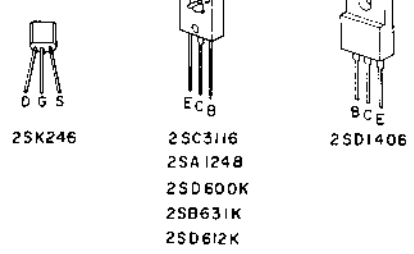

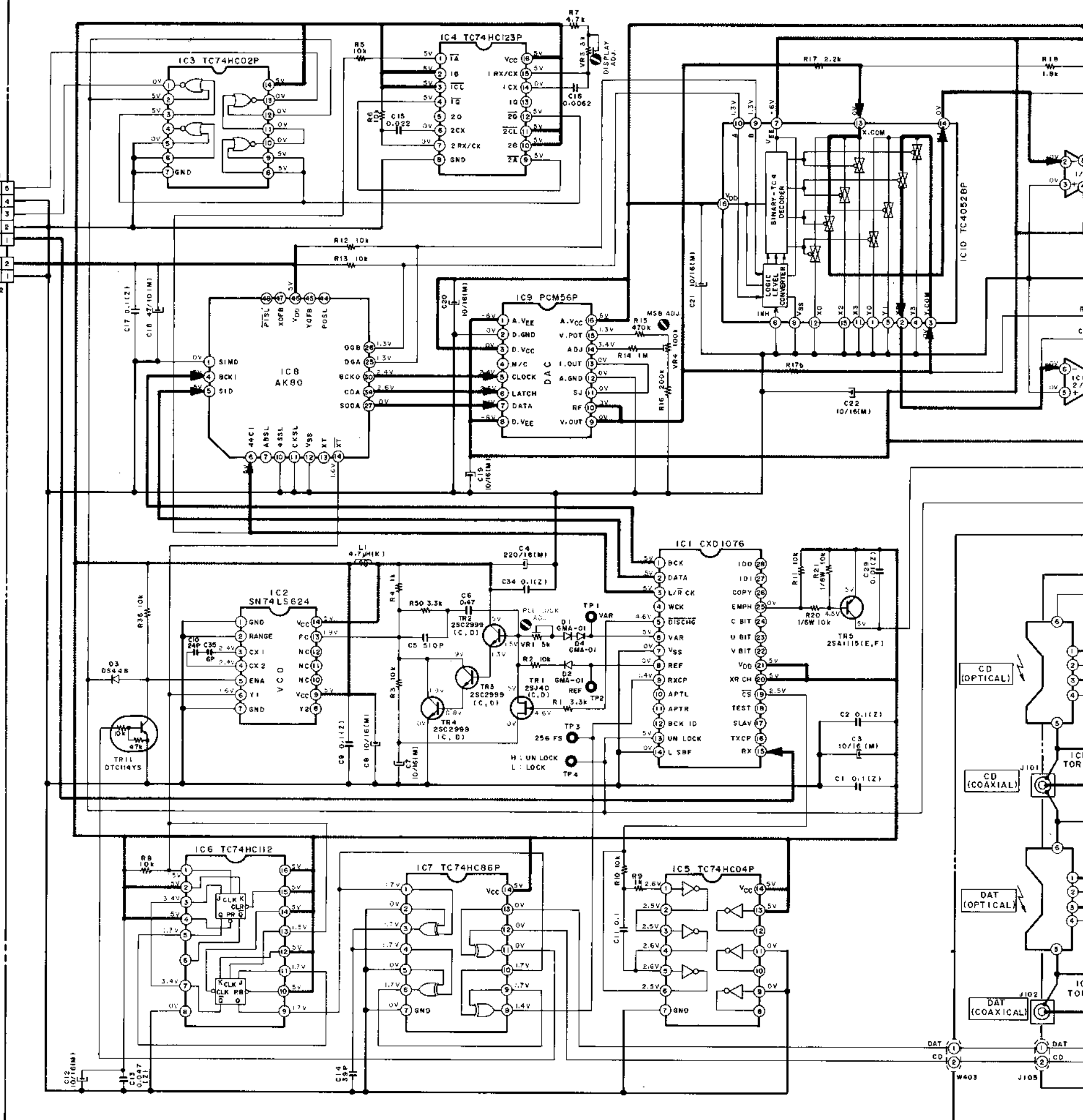

D/A PCB A2054A503A
D/A基板

2

3

4

5

6

7

8

6

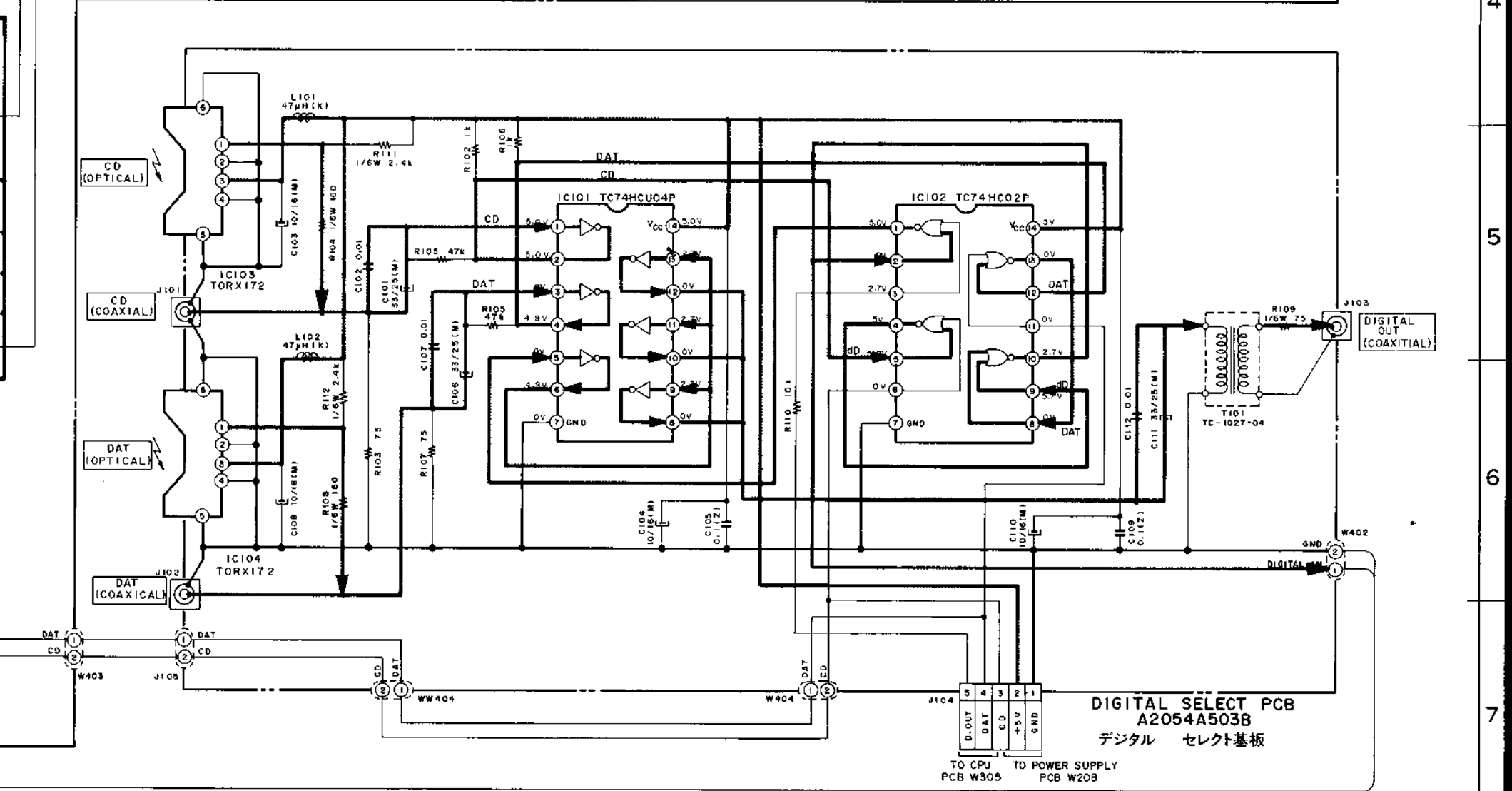
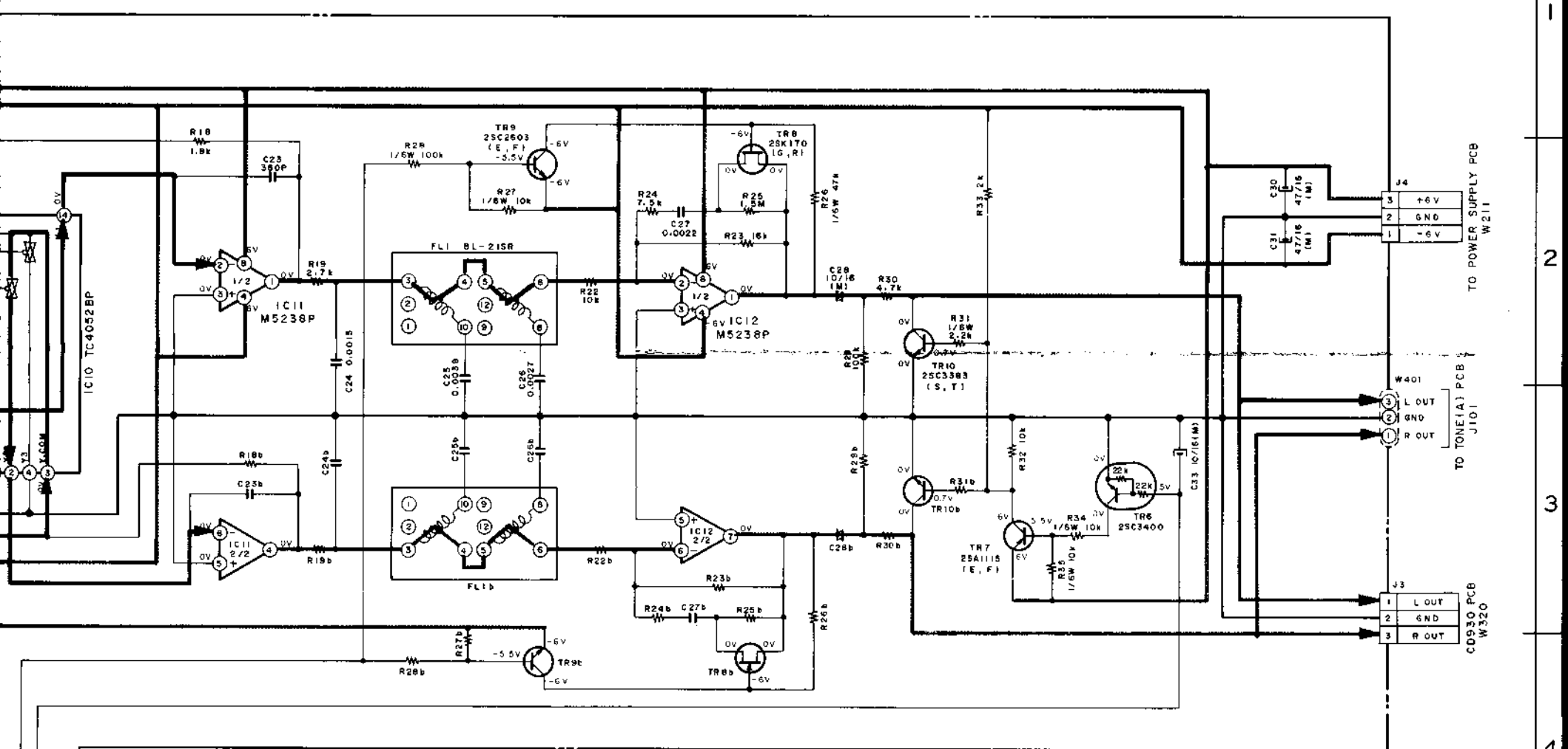

——— (POWER SUPPLY) LINE
 電源ライン
 ——— SIGNAL LINE
 信号ライン

MEASURED WITH DIGITAL VOLTMETER IN DC RANGE AT PLAY MODE.

NOTE
 UNLESS OTHERWISE SPECIFIED
 ALL RESISTORS IN OHMS 1/4W(J)
 ALL CAPACITORS IN μ F 50VV(J)

AM-M939
 D/A &
 DIGITAL SELECT
 SCHEMATIC DIAGRAM
 No.2-2 870908A

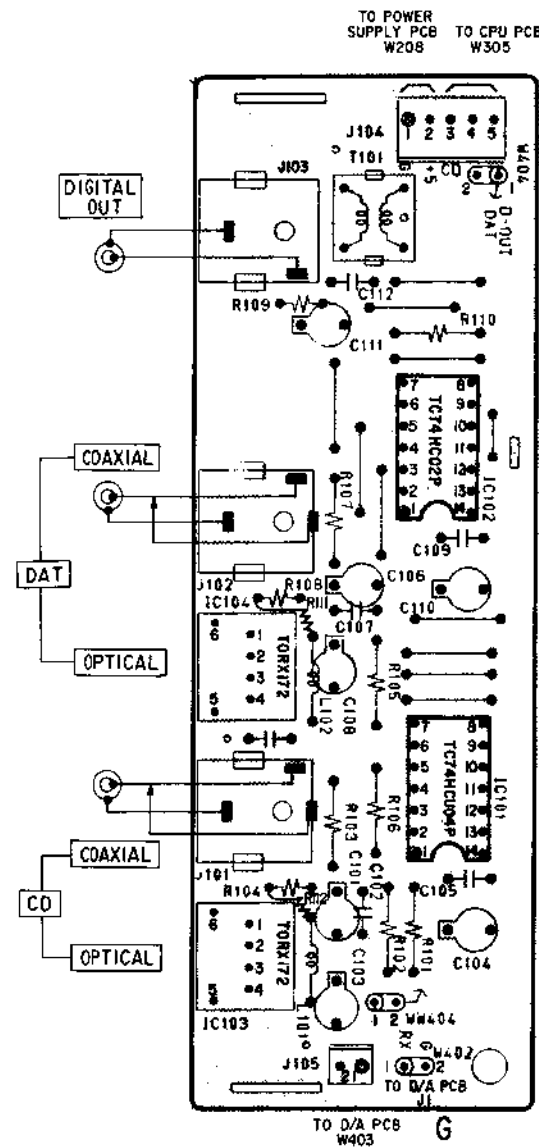

DIGITAL SELECT PCB A2054A503B
デジタルセレクト基板

LOCATION OF COMPONENTS

TRANSISTOR

- TR1 ----- 2SJ40
- TR2,3,4 ---- 2SC2999
- TR5,7 ----- 2SA1115
- TR6 ----- 2SC3400
- TR8,8b ---- 2SK170
- TR9,9b ---- 2SC2603
- TR10,10b --- 2SC3383
- TR11 ----- DTC114YS

IC

- IC1 ----- A1
- IC2 ----- C2
- IC3 ----- C3
- IC4 ----- D2
- IC5 ----- A3
- IC6 ----- B3
- IC7 ----- B1
- IC8 ----- C3
- IC9 ----- D3
- IC10 ----- D3
- IC11 ----- E3
- IC12 ----- F2
- IC101 ----- G3
- IC102 ----- G2
- IC103 ----- G3
- IC104 ----- G2

- TR1 ----- B2
- TR2 ----- B2
- TR3 ----- B2
- TR4 ----- B2
- TR5 ----- D1
- TR6 ----- E2
- TR7 ----- E1
- TR8 ----- E2
- TR8b ----- F2
- TR9 ----- E1
- TR9b ----- F1
- TR10 ----- E1
- TR10b ----- F1
- TR11 ----- B2

CONNECTOR

- J1 ----- A1
- J2 ----- B1
- J3 ----- E1
- J4 ----- E1
- J104 ----- G1
- J105 ----- G3

- B = NPN TRANSISTOR
- B = PNP TRANSISTOR
- B = FET
- S G D



2SJ40
2SK170



2SC2999
2SC3400
2SC2603
DTC114YS



2SA1115
2SC3383

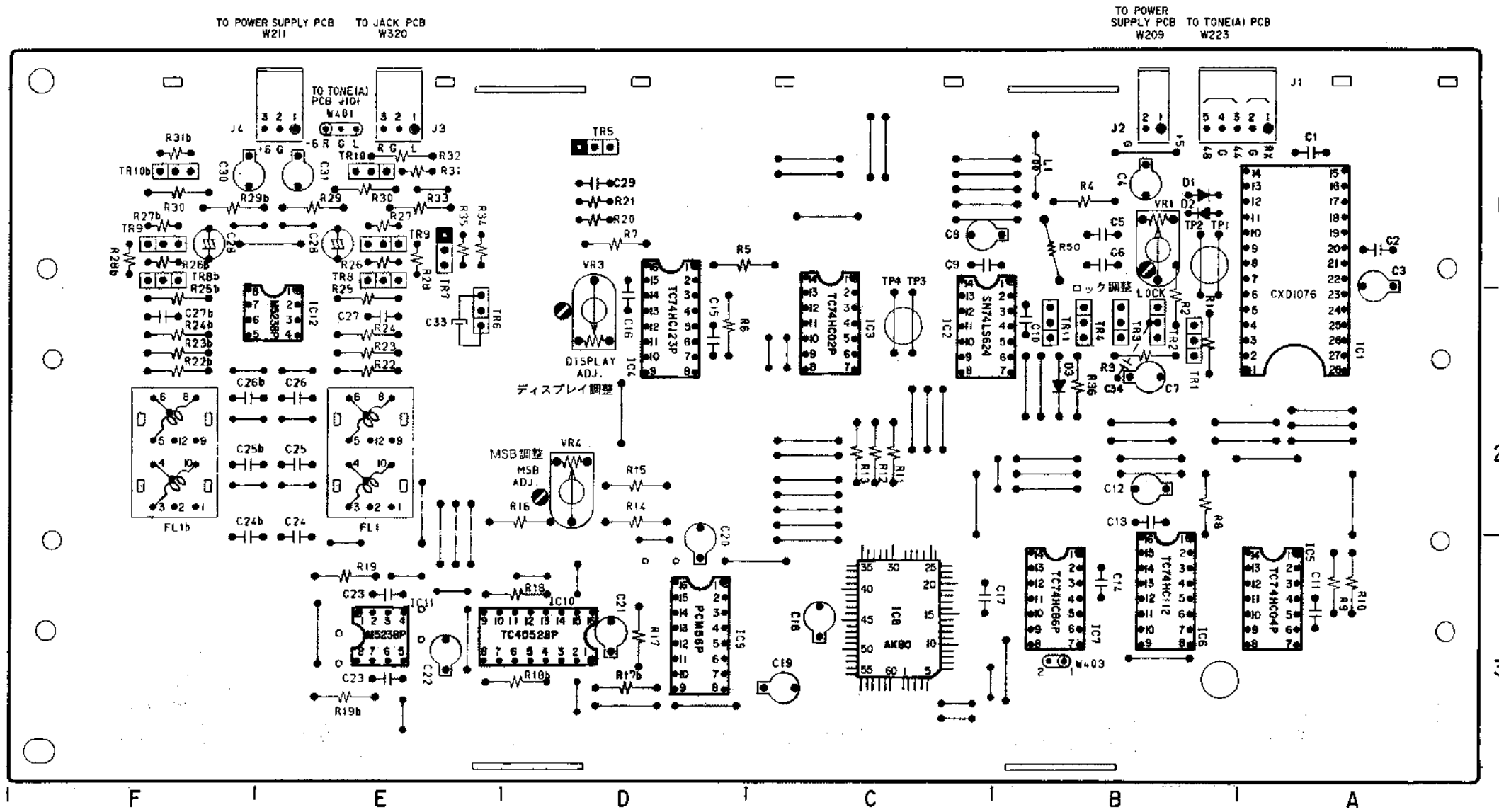

D/A PCB A2054A503A
D/A基板

1
2
3

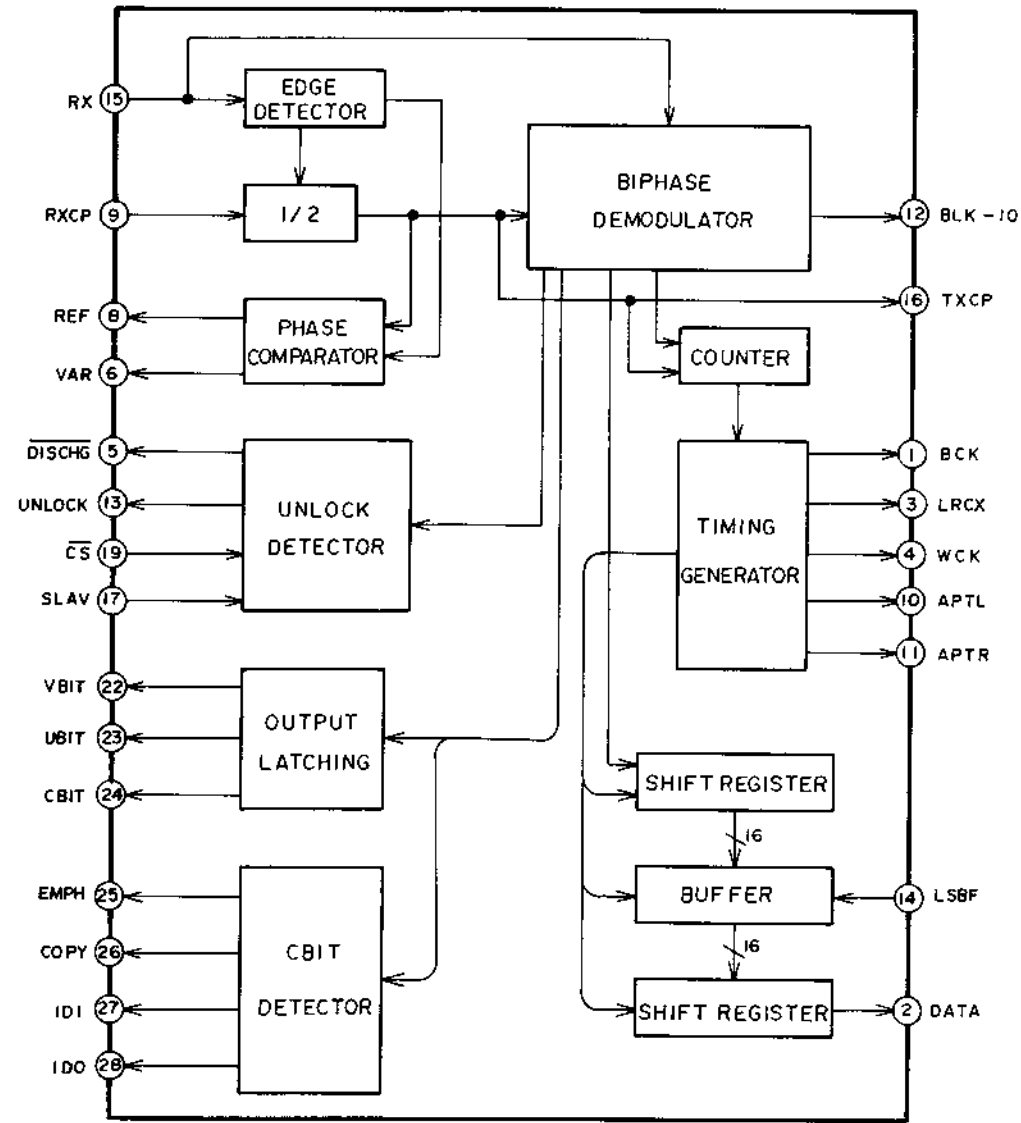

Pin No.	I/O	Name	Explanation of terminal
1	O	BCK	Shift clock output of digital audio data.
2	O	DATA	Serial output of demodulated digital audio data.
3	O	LRCK	Descriminate pulse output of L or R channels.
4	O	WCK	Word clock output.
5	O	DISCHG	Lock trigger pulse output when external PLL became unlock condition.
6	O	VAR	Low-Active pulse output to setting the sink current of external PLL.
7	-	V _{SS}	GND
8	O	REF	High-Active pulse output to setting the source current of external PLL.
9	I	RXCP	Clock input which abstracted by PLL. (256fs)
10	O	APTL	Pulse output for aperture correction.
11	O	APTR	Pulse output for aperture correction.
12	O	BLK-ID	Block detection pulse output for synchronizing the C-bit block.
13	O	UNLOCK	Lock detection output of PLL. (L = LOCK)
14	I	LSBF	
15	I	RX	Digital I/O data input which modulated by digital audio interface format.
16	O	TXCP	Clock (128 fs) output which using the master clock of external instruments.
17	I	SLAV	Control signal ("L" = Normal mode, "H" = Hi-impedance mode)
18	I	TEST	Control signal input of Normal or test modes. ("H" = TEST mode, "L" = NORMAL mode.)
19	I	CS	Clock input for mark the DISCHG pulse for PLL.
20	I	XRCH	Control input for the polarity set of LRCL. ("H" = L ch → High, R ch → Low, "L" = L ch → Low, R ch → High)
21	-	V _{DD}	Power supply
22	O	VBIT	Validity flag (V-bit) output.
23	O	UBIT	User definable data (U-bit) output.
24	O	CBIT	Channel status data (C-bit) output.
25	O	EMPH	Emphasis information output. ("H" = Emphasis ON)
26	O	COPY	Copy inhibit information output. ("L" = Inhibit)
27	O	ID1	ID1 output
28	O	ID2	ID2 output